

Steering Angle Sensor Communication Stop Mode

DESCRIPTION

Detection Item	Symptom	Trouble Area
STEERING ANGLE SENSOR COMMUNICATION STOP MODE	<ul style="list-style-type: none"> "STEERING SENSOR" is not displayed on the "Bus Check" screen of the intelligent tester via the CAN VIM. DTCs are output from each ECU in steering angle sensor communication stop mode as shown in the "DTC COMBINATION TABLE" (See page CA-7). 	<ul style="list-style-type: none"> Power source or inside the steering angle sensor Steering angle sensor sub bus line or connector

WIRING DIAGRAM

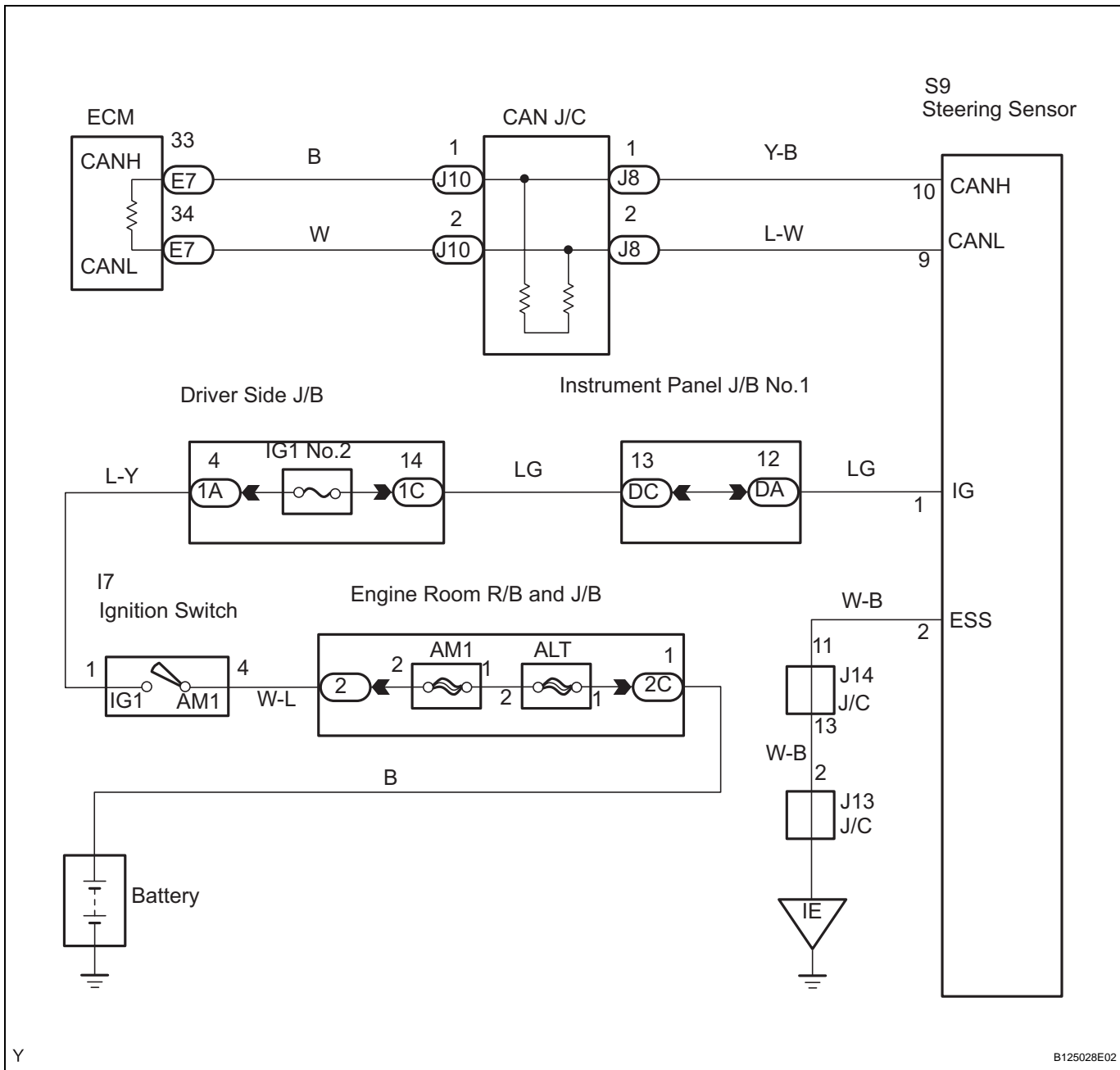

CA

1 CHECK CAN BUS LINE FOR DISCONNECTION (STEERING ANGLE SENSOR SUB BUS LINE)

Steering Angle Sensor Wire Harness View:

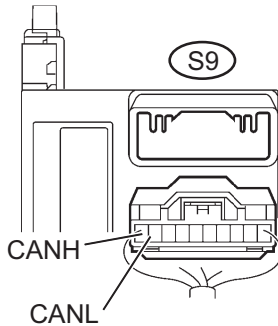

- Turn the ignition switch to the LOCK position.
- Disconnect the steering angle sensor connector (S9).
- Measure the resistance according to the value(s) in the table below.

Standard resistance

Tester Connection	Condition	Specified Value
S9-10 (CANH) - S9-9 (CANL)	<ul style="list-style-type: none"> Ignition switch OFF Stop light switch OFF 	54 to 69 Ω

NG

REPAIR OR REPLACE STEERING ANGLE SENSOR SUB BUS LINE OR CONNECTOR (CAN-H, CAN-L)

OK

2 CHECK WIRE HARNESS (IG1, ESS)

Steering Angle Sensor Wire Harness View:

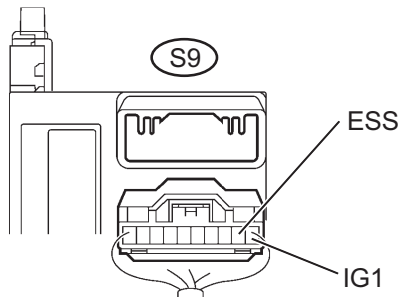

- Measure the resistance according to the value(s) in the table below.

Standard resistance

Tester Connection	Condition	Specified Value
S9-2 (ESS) - Body ground	Always	Below 1 Ω

- Measure the voltage according to the value(s) in the table below.

Standard voltage

Tester Connection	Condition	Specified Value
S9-1 (IG) - Body ground	<ul style="list-style-type: none"> Ignition switch ON Stop light switch OFF 	10 to 14 V

NG

REPAIR OR REPLACE WIRE HARNESS OR CONNECTOR

OK

REPLACE STEERING ANGLE SENSOR

CA