



International Bobsleigh Rules 2015

Table of Contents

1.	IBSF COMPETITIONS	7
1.1	<i>Olympic Winter Games</i>	7
1.1.1	Senior Olympic Winter Games.....	7
1.1.2	Youth Olympic Winter Games.....	7
1.2	<i>Championships</i>	7
1.2.1	Senior World Championships	7
1.2.2	Junior World Championships.....	7
1.2.3	Continental Championships.....	7
1.3	<i>Official IBSF Competitions</i>	7
1.3.1	World Cup Competitions	7
1.3.2	Intercontinental Cup Competitions.....	7
1.3.3	Europe Cup and North American Cup Competitions.....	7
1.3.4	International Competitions.....	7
1.4	<i>Test Competitions and Training Week</i>	7
1.5	<i>Allocation of Competitions</i>	8
1.6	<i>Gender</i>	8
2.	DISCIPLINES.....	9
2.1	<i>Men's Bobsleigh</i>	9
2.1.1	2-man Bobsleigh	9
2.1.2	4-man Bobsleigh (Men and/or Women).....	9
2.2	<i>Women's Bobsleigh</i>	9
2.2.1	2-man Bobsleigh	9
2.3	<i>Team Competition</i>	9
2.3.1	Men: One 2-man Bobsleigh and one Skeleton.....	9
2.3.2	Women: One 2-man Bobsleigh and one Skeleton	9
2.4	<i>Other Disciplines</i>	9
2.4.1	Monobob	9
2.4.2	Para Bobsleigh	9
2.4.3	Combined Event	9
2.4.4	Knockout System	9
3.	ADMISSION.....	9
4.	RIGHT TO PARTICIPATE IN COMPETITIONS	10
4.1	<i>Olympic Winter Games</i>	10
4.2	<i>Senior World Championships</i>	10
4.2.1	Requirements for participation in the Senior World Championships:.....	10
4.3	<i>Junior World Championships</i>	10
4.3.1	Requirements for participation in the Junior World Championships:	10
4.4	<i>Continental Championships</i>	10
4.4.1	Requirements for participation in the Continental Championships:.....	11
4.5	<i>World Cup and Intercontinental Cup</i>	11
4.5.1	World Cup.....	11
4.5.2	Intercontinental Cup	11
4.5.3	Requirements for participation in the World Cups and Intercontinental Cups:.....	11
4.6	<i>Europe Cup and North American Cup</i>	11
4.7	<i>International Competitions</i>	11
5.	EVENT	12
5.1	<i>General</i>	12
5.2	<i>Costs</i>	12
5.3	<i>Track</i>	12
5.4	<i>Event Announcements and Invitations</i>	12
5.5	<i>Organising Committee and Race Director</i>	12
5.6	<i>Technical Equipment</i>	13
5.7	<i>Liability Insurance</i>	13
5.8	<i>Further Obligations of the Organiser</i>	13
6.	JURY AND TECHNICAL DELEGATES	13
6.1	<i>Jury License</i>	13

6.2	<i>License for Material Controls</i>	13
6.3	<i>Nomination</i>	14
6.3.1	Olympic Winter Games	14
6.3.2	Senior World Championships	14
6.3.3	Junior World Championships, Continental Championships, World Cup and Intercontinental Cup	14
6.3.4	Europe Cup and North American Cup.....	14
6.3.5	International Competitions.....	14
6.4	<i>Authority</i>	14
6.4.1	Jury	14
6.4.2	Technical Delegates	15
6.4.3	Attendance	15
6.4.4	Expenses	15
6.4.5	Authority to Inspect.....	15
6.4.6	Special Decisions.....	15
7.	RACE DIRECTOR	15
7.1	<i>Appointment</i>	15
7.2	<i>Duties</i>	15
8.	GENERAL REGULATIONS	16
8.1	<i>Sporting Year</i>	16
8.2	<i>Liability</i>	16
8.3	<i>Amateurism Rules</i>	16
8.4	<i>Licenses</i>	16
8.5	<i>Insurance</i>	16
8.6	<i>Entries</i>	16
8.7	<i>Acceptance of the International Rules</i>	17
8.8	<i>Track Records and Start Records</i>	17
8.9	<i>Doping Controls</i>	17
8.10	<i>Rule Violations</i>	17
8.10.1	Athlete Support Person Rule Violations	18
8.10.2	Prohibited Association	18
8.10.3	Burden of Proof.....	18
8.11	<i>Sponsorship and Advertising</i>	18
8.12	<i>Trademarks on Equipment</i>	18
8.12.1	IBSF Properties	18
8.12.2	Freely Available Advertising Areas	18
9.	MEDICAL SERVICE AT THE TRACK	19
9.1	<i>Race Doctor</i>	19
9.2	<i>Team Doctor</i>	19
9.3	<i>Evacuation of injured athletes</i>	19
10.	THE COMPETITION	20
10.1	<i>Official Training</i>	20
10.1.1	Olympic Winter Games and Senior World Championships.....	20
10.1.2	Continental Championships, World Cup and Intercontinental Cup	20
10.1.3	Junior World Championships, Europe Cup and North American Cup	20
10.1.4	International Competitions.....	20
10.2	<i>Starting Order During Training</i>	21
10.3	<i>Track Conditions During Training</i>	21
10.4	<i>Start Grooves</i>	21
10.5	<i>Replacement of Athletes</i>	21
10.6	<i>The Race</i>	22
10.6.1	Race Heats	22
10.6.2	Starting Order	22
10.6.3	Starting Order System	22
10.6.4	Start Number	22
10.6.5	Teams and Manner of Driving.....	23
10.6.6	Track Conditions During the Race.....	23
10.6.7	Track Walks.....	23
10.6.8	Start	23
10.6.9	Reduction.....	23

10.6.10	Interruption or Cessation.....	23
10.6.11	Repetition of a Heat	23
10.6.12	Replacement Races	24
10.6.13	Pilot Sleds.....	24
10.6.14	Time Measurement	24
10.7	<i>Parc Fermé</i>	24
10.8	<i>Material and Equipment</i>	24
10.8.1	Sled.....	24
10.8.2	Runners	24
10.9	<i>Technical Inspections</i>	25
10.10	<i>Runner Radius</i>	26
10.11	<i>Measurement of Runner Temperatures</i>	26
10.12	<i>Reference Runner</i>	26
10.13	<i>Runner Cleaning</i>	26
10.14	<i>Weight</i>	27
10.15	<i>Electronic Measuring Devices and Equipment</i>	27
10.16	<i>Other Equipment</i>	27
10.16.1	Helmet.....	27
10.16.2	Shoes.....	28
10.16.3	Clothing	28
10.17	<i>Awards</i>	28
10.17.1	IBSF Championships.....	28
10.17.2	Official IBSF Competitions	28
10.18	<i>Awards Ceremony</i>	28
10.19	<i>Protests</i>	28
11.	RANKING LISTS	28
11.1	<i>Ranking List of the Race Series</i>	28
11.2	<i>IBSF Ranking List</i>	29
12.	FINAL CLAUSES.....	29
12.1	<i>Coming into Force</i>	29
12.2	<i>Modifications</i>	29
12.3	<i>Interpretation</i>	29
13.	APPENDIX 1: IBSF RANKING LIST "A"	30
14.	BOBSLEIGH CONSTRUCTIONS.....	31
14.1	<i>Principles and Properties</i>	31
14.1.1	Purpose of the Rules of 14.1	31
14.1.2	Principles	31
14.1.3	Bobsleigh Properties	31
14.2	<i>Bobsleigh Construction and Functioning</i>	32
14.2.1	Purpose of Rules of 14.2.....	32
14.2.2	General structure and Functioning	32
14.2.3	Frame and Running Gear.....	33
14.2.4	Cowling.....	38
14.2.5	Connection between Frame and Cowling.....	39
14.2.6	Bumpers	40
14.2.7	Runners	41
14.2.8	Detachable, moveable and/or adjustable parts	43
14.3	<i>Miscellaneous</i>	44
14.3.1	Purpose of 14.3	44
14.3.2	Principles and properties.....	44
14.3.3	List of Drawings and Figures	44
15.	DRAWINGS	46
15.1	APPENDIX 3: MATERIAL SEIZURE	58
15.2	<i>The Form</i>	58
15.3	<i>The Container</i>	58
15.4	<i>Remarks</i>	58
16.	APPENDIX 4: THE TRACK	60
16.1	<i>Scope</i>	60
16.2	<i>Environmental Protection</i>	60

16.3	Technical Commission.....	60
16.4	Preparatory Phase of Design.....	60
16.5	Design in General	60
16.6	Location of the Track.....	60
16.7	Length of the Track	60
16.8	Track Characteristics.....	61
16.9	Starting Area: Bobsleigh and Skeleton	61
16.9.1	Push-Off Stretch	61
16.9.2	Start Block (Wooden Board).....	61
16.9.3	Starting Area	61
16.9.4	Preparation.....	61
16.9.5	Start Procedure Time Limit.....	61
16.10	Luge Start	61
16.10.1	General Aspects	61
16.10.2	Starting Zone.....	61
16.10.3	Push-Off Grips.....	62
16.10.4	Starting Stretch.....	62
16.11	Bends	62
16.12	Guardrails in Bends.....	62
16.13	Centrifugal Force	62
16.14	Straights	62
16.15	Deceleration Stretch.....	63
16.16	Lighting.....	63
16.17	Solar and Weather Protection Devices	63
16.18	Water Supply.....	63
16.19	Catwalks	63
16.20	Infrastructures - Ancillary Facilities.....	63
16.21	Buildings at the Start and Finish	64
16.22	Partitioning of Costs	64
16.23	Exceptions	64
16.24	Homologation	64
17.	APPENDIX 5: ADVERTISING GUIDELINES AND DRAWINGS	65
18.	APPENDIX 6: THE IBSF AND THE ENVIRONMENT	67
18.1	Our Events	67
18.2	Seven steps to greening your event.....	67
18.2.1	Adopt a green policy.....	67
18.2.2	Carry out an 'Environmental Scoping Review' of venues and operations	67
18.2.3	Establish environmental teams	67
18.2.4	Define programmes and set appropriate targets	68
18.2.5	Implement programmes	68
18.2.6	Monitor implementation and adjust programme accordingly	68
18.2.7	Evaluate and publicise results	68
18.3	Action Plan.....	68
18.3.1	The impact of our sport	68
18.3.2	The Facility.....	68
18.4	Areas of action.....	69
18.4.1	Location and landscaping.....	69
18.4.2	Environmental elements to consider when choosing a location for sports venues are:	69
18.4.3	Natural resources:.....	69
18.4.4	Natural elements:.....	69
18.4.5	Perceptual elements:.....	69
18.4.6	Detailed planning, once the site location has been selected:	70
18.5	Sport facilities	70
18.5.1	Planning phase	70
18.5.2	Detailed planning	70
18.5.3	Construction phase	71
18.5.4	Operational phase	71
18.5.5	Sports equipment.....	71
18.5.6	Transportation	72

18.5.7	Energy	72
18.5.8	Accommodation and catering	73
18.5.9	Water management and sanitation	73
18.5.10	Waste management	74
18.6	<i>Large-scale Sports Events: Specific Recommendations</i>	74
18.6.1	Sports facilities.....	74
18.6.2	Transportation and air quality	74
18.6.3	Energy	75
18.6.4	Waste management	75
18.6.5	Environmental message to the public	75
18.6.6	Finances	75

1. IBSF COMPETITIONS

The IBSF competitions consist of the following events:

1.1 Olympic Winter Games

1.1.1 Senior Olympic Winter Games

1.1.2 Youth Olympic Winter Games

1.2 Championships

1.2.1 Senior World Championships

1.2.2 Junior World Championships

1.2.3 Continental Championships

1.3 Official IBSF Competitions

1.3.1 World Cup Competitions

1.3.2 Intercontinental Cup Competitions

1.3.3 Europe Cup and North American Cup Competitions

1.3.4 International Competitions

1.4 Test Competitions and Training Week

The Organisers of IBSF competitions to be staged on newly constructed tracks shall offer all Members enough training periods for their men's and women's bob teams in advance, during the preceding season, respectively during the same season of the competition within the same season.

Training runs prior to races are to be offered also on any tracks that have been subject to constructional changes.

The Organisers of the Winter Olympic Games to be staged on newly constructed tracks shall offer a number of at least 40 training and competition runs prior to the Games to all Members. These training runs and competition runs must be offered in the form of two or more International Training periods and/or test events, scheduled throughout the season.

Prior to the Games, the Organisers must also hold at least one test competition.

The quotas for participation in the International Training periods are the same as for the World Cup of the season in which the International Training periods are held.

All remaining Nations, which have no quotas for the participation in the World Cup, have the right to participate in the International Trainings periods with 1 men's bob team and 1 women's bob team, provided that their pilots (male pilots and female pilots) have taken part in and been ranked in, a minimum of 5 IBSF competitions on a minimum of 3 different tracks in the course of the previous 24 months.

Participation in 2-man bob events counts only for 2-man bob while participation in 4-man bob events counts only for 4-man bob.

The crews that do not have the right to compete in the World Cup, may not participate in the "Test event" but they can train during this time.

Moreover, for reasons of fairness and safety, immediately prior to the start of official training for the Olympic competitions (whether before or after the Opening Ceremony), the men's and women's bob teams registered for the Games must be given the possibility of at least 4 additional training runs.

Male and female pilots who in the previous and/or current season placed in the top 15 of the IBSF rankings for discipline and Combined cannot do additional training runs beyond the number prescribed by the present Article. This does not apply to athletes from the host country.

Moreover, the Organiser of the trainings periods and Text Event must grant that all participating athletes and their assistants/coaches will be provided with lodging in at least a three star hotel, full board, (bed + 3 meals) at a maximum price of 80 Euros per day.

The Organisers of the World Championships must offer an International Training period, to prepare for the championships and it must take place during the same competitive season in which the World Championships are organised. They are exempt from doing this if during the preceding competitive season a World Cup competition had been organised on the same track

During the periods in preparation for the Winter Olympic Games and/or World Championships, the Organiser shall offer training runs upon payment of the following amounts: a maximum of €15 for each 2-man bobsleigh training run and a maximum of €25 for each 4-man bobsleigh training run. At least 6 training runs in 2-man bobsleigh and 6 training runs in 4-man bobsleigh shall be offered.

If the training week is to be staged as a test competition, the Organiser must offer the runs free of charge.

However, the Organiser may require payment of the entry fee.

1.5 Allocation of Competitions

a) World Championships

The Congress assigns the World Championships to the respective Member Federations a maximum of four years in advance upon written application.

b) Official IBSF Competitions

The remaining official IBSF competitions are assigned yearly by the IBSF Executive Committee, and must be listed on the IBSF International Calendar.

1.6 Gender

If the IBSF International Rules do not explicitly indicate the gender, they apply to both men's and women's bobsleigh.

2. DISCIPLINES

The following disciplines are contested:

2.1 Men's Bobsleigh

2.1.1 2-man Bobsleigh

2.1.2 4-man Bobsleigh (Men and/or Women)

2.2 Women's Bobsleigh

2.2.1 2-man Bobsleigh

2.3 Team Competition

2.3.1 Men: One 2-man Bobsleigh and one Skeleton

2.3.2 Women: One 2-man Bobsleigh and one Skeleton

2.4 Other Disciplines

2.4.1 Monobob

2.4.2 Para Bobsleigh

2.4.3 Combined Event

2.4.4 Knockout System

3. ADMISSION

The right to participate in championships and official IBSF competitions is reserved only for teams registered by Members, i.e. teams from

- MEMBERS or
- ASSOCIATE MEMBERS.

The athletes must fulfill one of the following conditions:

- They must hold citizenship of the nation of the Member or Associate Member concerned, and may not have taken part in international IBSF competitions on behalf of another Member /Associate Member, or
- They must have their official residence in the Member/Associate Member concerned, and may not have taken part in international IBSF competitions on behalf of another Member/Associate Member, or
- They must have changed their citizenship or their official residence, and have been released by their former Member/Associate Member and accepted by their member. In this case, the athlete may represent one of the two members, but not both.

An athlete may represent only one nation during any competition season, which lasts from October 1 to September 30 of the following year.

Applications to change Member may only be submitted between April 01 and September 30 of each year.

When athletes switch Nations, they keep their Scores/Ranking in the IBSF Ranking List, as well as the number of competitions in which they have participated; however, they do not keep the right to the previous quotas for participation, which remains tied to the nation of origin

4. RIGHT TO PARTICIPATE IN COMPETITIONS

4.1 Olympic Winter Games

The criteria for the right to participate in the Olympic Winter Games are determined by the IOC. The qualification rules are determined by the IOC in collaboration with the IBSF. The qualification rules are communicated directly by the IOC to all National Olympic Committees.

4.2 Senior World Championships

The Senior World Championships take place annually, with the exception of the Olympic year. Quotas are based on the current IBSF Discipline Ranking List.

The quotas for participation in the Senior World Championships are as follows:

Men:	Nations with 3 teams in the Top 25: 3 starting places
	Nations with 2 teams in the Top 50: 2 starting places
	Nations with 1 team in the Top 55: 1 starting place
	All remaining nations with 1 team
Women:	Nations with 3 teams in the Top 25: 3 starting places
	Nations with 2 teams in the Top 35: 2 starting places
	Nations with 1 team in the Top 40: 1 starting place
	All remaining nations with 1 team

4.2.1 Requirements for participation in the Senior World Championships:

Only those pilots can take part who have been participating and ranked in a minimum of 5 IBSF races on at least 3 different tracks in the 24 months prior to the competition. In addition the pilot must have been ranked in at least 3 of the 5 above mentioned races on a minimum of 2 different tracks during the on-going season. Participation in 2-man bobsleigh competitions counts only for 2-man bobsleigh, while participation in 4-man bobsleigh competitions counts only for 4-man bobsleigh.

The defending Junior World Champion team is also entitled to participate.

4.3 Junior World Championships

The Junior World Championships take place annually. Only athletes from the Junior category may participate. All National Federations may participate with a maximum of 3 teams.

4.3.1 Requirements for participation in the Junior World Championships:

Participation is allowed only for pilots who have taken part in, and been ranked in, a minimum of 3 IBSF competitions on a minimum of 2 different tracks in the course of the previous 24 months. Participation in 2-man bobsleigh competitions counts only for 2-man bobsleigh, while participation in 4-man bobsleigh competitions counts only for 4-man bobsleigh.

Juniors are athletes who have not yet reached the age of 26 years on the date of the Junior race. Furthermore, Juniors are all those athletes who reach the age of 26 years in the period of October 1 to March 31 of the current season.

4.4 Continental Championships

The quotas for participation in the Continental Championships are identical to those of the World Cup if the Championships are held within the course of a World Cup competition. Nations of the respective continent that are not qualified to participate in the World Cup have the right to participate with one team. These teams are ranked only in the Continental Championships and shall receive no World Cup points. They will start at the end of the field according to their IBSF ranking by discipline. Teams with

no points will be drawn. They are drawn separately at the end of the field of competitors. In the second race heat, they start according to their ranking after the first heat.

4.4.1 Requirements for participation in the Continental Championships:

Participation is allowed only for pilots who have taken part in, and been ranked in, a minimum of 5 IBSF competitions on a minimum of 3 different tracks in the course of the previous 24 months. Participation in 2-man bobsleigh competitions counts only for 2-man bobsleigh, while participation in 4-man bobsleigh competitions counts only for 4-man bobsleigh.

4.5 World Cup and Intercontinental Cup

Quotas for the new season are based on the final results of the previous year's Combined IBSF Ranking List.

The Combined IBSF Ranking List includes only those pilots who competed both in the two-man and four-man bob.

4.5.1 World Cup

The quotas for participation are determined as follows:

Men:	Nations with 3 teams in the Top 25: 3 starting places
	Nations with 2 teams in the Top 50: 2 starting places
	Nations with 1 team in the Top 55: 1 starting place
Women:	Nations with 3 teams in the Top 25: 3 starting places
	Nations with 2 teams in the Top 35: 2 starting places
	Nations with 1 team in the Top 40: 1 starting place

4.5.2 Intercontinental Cup

The quotas for participation are determined as follows:

Men:	4 nations with 3 teams
	6 nations with 2 teams
	all remaining nations with 1 team
Women:	Competitions not held

4.5.3 Requirements for participation in the World Cups and Intercontinental Cups:

Participation is allowed only for pilots who have taken part in, and been ranked in, a minimum of 5 IBSF competitions on a minimum of 3 different tracks in the course of the previous 24 months. Participation in 2-man bobsleigh competitions counts only for 2-man bobsleigh, while participation in 4-man bobsleigh competitions counts only for 4-man bobsleigh.

4.6 Europe Cup and North American Cup

All nations may participate and score points with a maximum of 4 teams.

The pilots (male and female) placed among the top 12 of the current IBSF discipline ranking will not be admitted either to the Europe Cup races or to the North American Cup races, unless the respective nation uses its entire WC quota.

4.7 International Competitions

The Organiser establishes the right to participate in the event announcement.

5. EVENT

5.1 General

Only the IBSF, as well as its Members and Associate Members, have the right to organise international competitions.

All official international IBSF competitions shall be organised under the supervision of the IBSF. The IBSF shall award the competition to a Member or Associate Member that is able to undertake the organisation of the competition, or is able to pass it on to an association (Club) or an Organising Committee. The Member or Associate Member remains responsible for the orderly execution of the event.

5.2 Costs

The Organiser to whom the organisation of the event has been awarded assumes the entire organisation and its costs.

5.3 Track

The Organiser shall make the track available in the best possible condition for the official training and the race. The usage of the track during the official training and the race is free of charge.

5.4 Event Announcements and Invitations

The Organiser of the competition shall be responsible for the event announcements and invitations.

The Organiser must present the official event announcement with the program schedule to the IBSF Executive Committee for approval by August 15.

The Organiser must send the program schedule to the Member Federations and the appointed Jury Members within two weeks of receiving the approval of the IBSF

The event announcement must include:

- The name of the competition
- The location and date of the competition
- A schedule for the official training and the race
- A short description of the track, including a sketch of the track
- The entry deadline
- The address of the Organising Committee with exact office times, telephone number, fax number and e-mail address
- The name of the Chief of Organisation
- The name of the Race Director
- The names of the Jury Members and the Technical Delegate, if any
- Information about facilities, benefits and hotel accommodations
- Any conditions of entry
- The location and time of the first team captains' meeting

5.5 Organising Committee and Race Director

An Organising Committee and a Race Management Office shall be formed in order to guarantee the orderly execution of the event.

The Race Director must possess an IBSF International Jury License. He is responsible for ensuring that the entire event is carried out in accordance with the IBSF International Rules. He shall ensure that skilled and responsible people hold all the important positions in order to assure the smooth progression of the event. Furthermore, he is obliged to ensure that the track is in perfect condition and that the safety of the athletes, coaches and spectators is guaranteed.

5.6 Technical Equipment

- Voice communication among the start, the finish and the timekeepers
- Voice communication between the Race Director and the Jury
- Numerous loudspeakers
- At least two calibrated instruments for measuring runner temperature
- An electronic timing system
- A room for team captains' meetings
- Sufficient changing rooms and sanitary facilities
- A weigh scale, calibrated every year,
- Sufficient transport vehicles
- A first aid room
- Medical service
- A doping control room
- Video surveillance on the track
- A room suitable for technical inspections of sleds and runners
- A suitable room, possibly next to the start, equipped with Internet connection for the Jury
- Sufficient computers and photocopiers
- A score board
- Optical and acoustic devices to authorize the start

5.7 Liability Insurance

The Organiser is obliged to obtain sufficient public liability insurance.

The insurance must cover the IBSF staff involved in the respective competition.

5.8 Further Obligations of the Organiser

The obligations of the Organiser of IBSF competitions are specified in writing within the framework of a contract that is negotiated between the IBSF and the Organiser's National Federation.

Race results must be forwarded to the media and the IBSF immediately after the conclusion of the event. Training and race results must be distributed to the team captains as quickly as possible. If possible, the results should also be accessible online.

6. JURY AND TECHNICAL DELEGATES

6.1 Jury License

The Jury Members and Technical Delegates, appointed by the IBSF Executive Committee, must possess an IBSF International Jury License in order to officiate. Each National Federation has the right to recommend people suitable for obtaining an IBSF International Jury License.

This License can be acquired after taking an examination on the IBSF International Rules for Bobsleigh and Skeleton. In principle, the examinations take place two times per year, on the occasion of the Senior World Championships and of a World Cup competition on a different continent. The respective National Federations must register potential candidates with the IBSF General Secretary in advance (at least one-month prior).

6.2 License for Material Controls

In order to be allowed to execute their office, the Material Controllers appointed by the Executive Committee must have an International Material Controller License of the IBSF. Each National Federation has the right to propose candidates who are eligible to obtain the International Material Controller License of the IBSF. The examinations will be held as specified by IBSF announcement. The

respective National Federations must register potential candidates with the IBSF Secretary General in advance (at least one month prior).

6.3 Nomination

The IBSF Executive Committee nominates the Juries and the Material Controllers. The National Federations have the right to make recommendations.

6.3.1 Olympic Winter Games

- one or two Technical Delegates
- a Jury President
- two Jury Members
- two Jury Assistants, if required
- two or three Material Controllers

6.3.2 Senior World Championships

- One or two Technical Delegates
- a Jury President
- two Jury Members
- two Jury Assistants, if required
- two Material Controllers

6.3.3 Junior World Championships, Continental Championships, World Cup and Intercontinental Cup

- One or two Technical Delegates
- a Jury President
- two Jury Members
- Jury Assistants, if required
- two Material Controllers

6.3.4 Europe Cup and North American Cup

- One or two Technical Delegates
- a Jury President
- one or two Jury members
- one or two Material Controllers

6.3.5 International Competitions

A Jury President or a Technical Delegate who represents the IBSF, with the task of controlling and supervising the event

6.4 Authority

6.4.1 Jury

The Jury is the highest authority of the competition and implements control with the right to make final judgments within the scope of the IBSF International Rules.

The decision of the Jury is final, incontestable and takes effect immediately.

Furthermore, the Jury is responsible for:

Potential changes of the ice temperature

- Any change of sleds
- Any change of runners
- Any repetition of a heat
- Any reduction in the number of training runs
- Any interruption or cessation of the race, after consultation with the Race Director and the Chief of Track
- Any reduction in the number of participants

- Any penalties for rule violations
- The length of the start grooves
- The number of pilot sleds
- The temperature and weight checks
- Decisions regarding protests
- Any suspension of athletes
- Closing the track in case of danger

6.4.2 Technical Delegates

During the Olympic Winter Games one Technical Delegate for Bobsleigh, one Technical Delegate for Skeleton and one additional Technical Delegate are to be appointed. During the Senior World Championships one Technical Delegate for Bobsleigh and one Technical Delegate for Skeleton are to be appointed.

In principle, for all other IBSF events only one Technical Delegate may be appointed for both disciplines.

The power to make decisions regarding the event lies exclusively with the Jury.

If no Technical Delegate has been appointed, the Jury President acts automatically also as Technical Delegate.

6.4.3 Attendance

The Jury President must be available from the first team captains' meeting onward. The Jury is responsible for the compliance with the IBSF International Rules from the start of the official training to the end of the awards ceremony. In cases of absence of a Jury Member, the IBSF appoints a substitute.

6.4.4 Expenses

The IBSF Executive Management Committee determines annually the reimbursement of allowable expenses of the Jury and the Technical Delegate, and informs all concerned by circular letter.

6.4.5 Authority to Inspect

During the training and the race, the Technical Delegate and each Jury Member shall have access without prior notification to all technical equipment and facilities necessary to hold the competition.

6.4.6 Special Decisions

The Jury is also responsible for all decisions pertaining to the competition that are not specified in these Rules.

7. RACE DIRECTOR

7.1 Appointment

The Race Director, appointed by the Organiser, must possess an IBSF International Jury License for all official IBSF competitions.

7.2 Duties

The Race Director is responsible for ensuring that, under the direction of the Jury, all measures are taken that are necessary for the orderly progression of the competition according to the IBSF International Rules. This includes the progression of the team captains' meetings, the training and the race.

Potential necessary changes taken on short notice must first be arranged with the Jury and the Sport Director.

The Race Director decides upon the use of sunshades during rain, snowfall, or sunshine. He shall inform the Jury President immediately about all decisions.

8. GENERAL REGULATIONS

8.1 Sporting Year

The sporting year of the IBSF runs from October 1 to September 30 of the following year.

8.2 Liability

The IBSF assumes no liability for accidents, damages, or other claims that should result from the allocation of the competition or from its proceedings.

8.3 Amateurism Rules

The rules of the IOC are adopted here.

8.4 Licenses

All athletes must be electronically registered by their National Federation for an IBSF International License prior to participating in the sport of bobsleigh. The minimum age for athletes for obtaining an IBSF International License is 15 years of age. However, athletes who will turn 15 years of age during October 1st and March 31st of the current season are eligible to apply for an IBSF International License as well. This applies for men's and women's bobsleigh. However, the minimum age for the Monobob events is 14 years of age. Athletes under the age of 18 require the permission of their parents or legal guardian in order to exercise the sport of bobsleigh. The parents or legal guardian must sign the letter of permission and the signature must be officially certified.

The IBSF Electronic License must be filled out in all details and certified by the President or a duly authorized Officer of the National Federation and submitted with a digital photograph.

By registering for a license, the National Federation verifies and confirms that the athlete:

- has had a medical check and has met the medical requirements for bobsleigh;
- is covered by insurance against accidents deriving from the practice of bobsleigh training or racing;
- is covered by insurance against liability;
- has been issued the IBSF International and Anti-Doping Rules and
- has signed a form in which the athlete declares to comply with the IBSF International and Anti-Doping Rules.
- has signed a copy of the IBSF Athlete Code of Conduct

The license is valid for 12 months (October 1 to September 30).

8.5 Insurance

The Member Federations of the IBSF are responsible for ensuring that each of their athletes is sufficiently covered by accident and disability insurance, as well as public and third party liability insurance for risks that may arise from an accident must be completely covered by the insurance.

8.6 Entries

a) Prior to the deadline specified in the event announcement, the Members shall inform the Organiser of the competition by entering online the teams for the competition.

b) The Members are obligated to inform the IBSF Secretary General of the names of those people who are authorized to submit entries.

c) The entry fees belong to the Organiser and amount to the value of €20 per athlete.

d) Additional team members may be entered during the first TCM. For late entries a fee of € 40, 00 per athlete will be charged.

e) The name of the team captain shall be given to the Jury at the first team captains' meeting.

f) The **team captain** must communicate the names of the team members, who will compete in the race, prior to the draw.

g) If the entry deadline specified in the event announcement is not observed, the entry can be accepted for double the entry fee.

Entries may be withdrawn at any time. Entry fees already paid are not refunded.

Entry fees must be paid at the first team captains' meeting.

8.7 Acceptance of the International Rules

With the submission of the entry, the participants (athletes, team captains, coaches and support staff) accept these Rules as binding.

8.8 Track Records and Start Records

Track records and start records will only be recognized by the IBSF if they have been performed during official international IBSF races. The record may be recognized if the team has been subjected to a weight test and their sled to a technical inspection during the competition. If the record is equaled in a subsequent race heat, it does not count as a record. In the event of a draw in the same race heat, more than one team may be listed as the record holders. The record cannot be recognized until it has been stated that there have been no violations of the IBSF International Rules.

8.9 Doping Controls

Doping is prohibited.

The IBSF Executive Committee can arrange for doping controls at all IBSF competitions and at any time outside of the competitions.

The doping controls are carried out according to the IBSF Anti-Doping Regulations.

The IBSF Executive Committee can authorize international specialized facilities to carry out these controls.

By signing the IBSF International License, the athlete is obliged to accept the IBSF Anti-Doping Regulations and to submit to the controls determined by the IBSF Executive Committee.

By signing the Acknowledgement and Agreement, the athletes, team captains, technicians, coaches and support staff recognize the new IBSF Anti-Doping Regulations.

8.10 Rule Violations

The Jury is responsible for the compliance with the IBSF International Rules from the first Team Captains' Meeting to the end of the awards ceremony.

The Jury determines the penalties for violations against the provisions of the International Rules according to the gravity of the offence:

- A warning
- A fine
- Disqualification from the competition
- Application to the Executive Committee to suspend the pilot as well as the whole team for several races

- Application for withdrawal of the license to the Executive Committee.
The athlete concerned or his National Federation has the right to defend himself before a final decision is made regarding the cancellation of the International License.
The fine is collected by the Jury, which forwards it to the IBSF

8.10.1 Athlete Support Person Rule Violations

An Athlete Support Person (Coach, sled or runner builder, physio or any other person) may be deemed to have broken or contributed to the breaking of IBSF Rules. In this case the Jury determines the penalties for violations against the provisions of the IBSF International Rules according to the gravity of the offence:

- a warning
- a fine
- disqualification from the competition / venue
- application for disqualification from future IBSF competitions to the Executive Committee

8.10.2 Prohibited Association

Prohibited Association: In the event that an Athlete Support Person is disqualified from an IBSF event or events (8.10.1) it is prohibited for an athlete (athletes, team or nation) to associate with this person for the duration of their disqualification. If after receiving a written warning the athlete (athletes, team or nation) continues to associate with the disqualified person the athlete (athletes, team or nation) may be given a

- a fine
- disqualification from the competition
- disqualification from future competitions

In order for this provision to apply, it is necessary that the athlete (athletes, team or nation) has been advised in writing by the IBSF of the Athlete Support Person's disqualifying status and the potential consequence of prohibited association and that the athlete can reasonably avoid the association.

8.10.3 Burden of Proof

The burden shall be on the athlete (athletes, team or nation) to establish that any association with the Athlete Support Personnel described in Article 8.10.1 or 8.10.2 is not in a professional or sport- related capacity.

8.11 Sponsorship and Advertising

The IBSF and its Member Federations can negotiate contracts with commercial firms or organisations.

8.12 Trademarks on Equipment

8.12.1 IBSF Properties

The IBSF property areas for advertising with sponsors or similar entities are governed by the IBSF Advertising Guidelines. The specifications established therein shall be followed. Violations result in penalties.

8.12.2 Freely Available Advertising Areas

With the exception of the areas entitled to the IBSF in accordance with the IBSF Advertising Guidelines, unlimited advertising may be placed on the sled, the equipment and the athlete.

9. MEDICAL SERVICE AT THE TRACK

9.1 Race Doctor

The following must be available at the track during the official training runs and the race heats with the exception of World Cup race days and World Championship race days:

- One medical specialist with knowledge of emergency medical aid
- One ambulance equipped with appropriate resuscitation equipment at all times
- One room exclusively used for first aid treatment – which is marked as such.

World Cup race day and World Championship Race day:

- One medical specialist with knowledge of emergency medical aid
- two ambulance equipped with appropriate resuscitation equipment at all times – in case one ambulance leaves the track a second one has to be called immediately; if two ambulances leave the track the race must be stopped.
- One room exclusively used for first aid treatment – which is marked as such.

Should the race doctor and/or ambulance be medically required, the race or official training must be interrupted until their services are again guaranteed.

The Organiser shall be attentive to this regulation, as the Organiser is responsible for compliance with these requirements.

The IBSF Medical Committee decides on any possible exceptions to the above. The Jury President must be informed of these exceptions prior to the start of the official training.

Tasks of the Race Doctor:

- He is responsible for the first medical aid for injuries and illnesses of the athlete
- He directs the transportation of injured or ill athletes for further medical treatment
- After every crash, the athlete must come to the Race Doctor for an examination in order to obtain the authorization to participate further in the training or in the race.
- If the Race Doctor suspects a concussion, he is entitled to prohibit the concerned athlete from further participation. In these cases, the Race Doctor must immediately inform the Jury President of the athlete's inability to continue to participate in the competition, and the athlete is accordingly officially removed from the competition.
- The Race Doctor must inform the Jury President immediately who will inform the IBSF office to temporarily unlicense the concerned athlete.
- The Race Doctor must complete an Injury Registration Document after every examination of an injured athlete.
- At the end of the competition, all of these documents (including timesheets) must immediately be forwarded to the IBSF office and Chairman of the IBSF Medical Committee.

9.2 Team Doctor

Race doctor and team doctors should cooperate on evaluation and treatment.

9.3 Evacuation of injured athletes

The event Organisers must guarantee that injured athletes can be transported away from any point of the entire length of the track.

10. THE COMPETITION

10.1 Official Training

Participation in the official training is only permitted for registered athletes for the competition. During a competition (the official training and the race), pilots are not permitted to make runs on the track outside of the official program schedule, nor are they permitted to conduct training or races on other tracks at the same time or compete on more than one circuit. Replacement pilots who start participating in the official training at a later stage, may have made training runs on other tracks.

10.1.1 Olympic Winter Games and Senior World Championships

Directly prior to the race, 6 official training runs in each of 2-man bobsleigh and 4-man bobsleigh shall be offered.

10.1.2 Continental Championships, World Cup and Intercontinental Cup

Directly prior to the race, 3 days of official training with a total of 6 official training runs (2-man bobsleigh and 4-man bobsleigh combined) shall be offered. Each pilot may freely choose the program by which he makes his training runs. However, he may only take a maximum of 4 training runs in any discipline. For women 6 official training runs shall be offered. For men and women a minimum of two valid training runs per discipline without accidents must be completed in order to be allowed to participate in the race. A Nation may sign up different pilots for the two-man and four-man bobsleigh competitions. In this case the nation will be assigned one additional training run for each additional pilot (pilot in addition to the quota) up to a maximum of 4 runs per pilot/discipline. The nation may assign the available runs to the various pilots according to its own choice. Only one additional pilot per training day is admitted.

In the case the number of training runs/days is reduced, a pilot who participates in one discipline only may make the same maximum number of runs per discipline as a pilot who participates in combined disciplines.

The pilots who participate in combined races, i.e. two-man and four-man races, and have not made any training and race runs previously on the respective track, may make two additional training runs during the World Cup events up to a maximum of four runs per discipline. These runs are to be announced during the first team captains' meeting and will be granted by the Jury after consultation with the team captain and the race organizer. No additional training day will be offered. The additional runs must be completed during the normally scheduled training days.

10.1.3 Junior World Championships, Europe Cup and North American Cup

These competitions can be done according to the World Cup program: training runs can be done during the week whereas competition runs will be held on the weekend.

Teams performing in both disciplines have a right of a maximum of 10 training heats. The teams can choose on which day they want to do 2-men or 4-men training.

Teams just performing in one discipline have a right – if possible – of 2 training runs each on all training days.

To be admitted to the race teams need to have at least two training runs without any accident and according to the IBSF rules.

If there are double-races training and competition runs can be separated as before. That means there will be training runs in 2-men first, than 2-men competition, followed by 4-men training runs and 4-men competition.

10.1.4 International Competitions

The Organiser determines the number of official training runs. A minimum of 3 official training runs must be offered.

The IBSF Executive Committee can modify the number of official training days and / or training runs in official IBSF competitions. However, the change in the number of official training days and / or training runs must be declared in the event announcement.

At all official IBSF competitions, each pilot must complete two training runs without accident to be allowed to participate in the race.

10.2 Starting Order During Training

The starting order of the participating nations shall be drawn at the first team captains' meeting. If possible, the training is run according to "nation groups".

The following starting order applies for events in which the official training takes place for 2 or 3 days:

- 1st day: From nation 1 to the end
- 2nd day: From the end to nation 1
- 3rd day: by individual according to the 2-man bob IBSF ranking (based on best-placed pilots present/starting, women and men separately)

During the World Championships and the Olympic Games the starting order for two-man and four-man bob will be defined on the basis of the IBSF ranking of each of these two disciplines.

10.3 Track Conditions During Training

If possible, the final day of official training should take place at the same time as the race and the track preparation should correspond to the conditions of the race. No alterations to the track profile should be made after the final training session.

10.4 Start Grooves

The start grooves are determined by the Jury on the first day of training and can only be modified upon their command. Both grooves shall be prepared appropriately for skeleton runners (17 mm diameter).

10.5 Replacement of Athletes

It is possible to replace an athlete with another athlete from the same National Federation at any time during training. However, a pilot may only be replaced if the replacement pilot is still able to achieve the minimum number of accident-free training runs without a change in the program schedule.

A pilot who carries out runs beyond the official training (for example, as a forerunner or in the "guests" class) cannot take part in the competition later on. The jury can make an "exception" to allow such pilot's participation in the "Team Competition"; however, this exception must be declared during the first meeting with the team captains.

Double Competition

During double competitions on the same track, the National Federations can sign up different pilots for the second competition from those participating in the first competition.

The new pilots will be given the same number of training runs as the other teams. This applies only for World Cup and North American Cup, whereas in Europe Cup only one new pilot may use the same number of training runs. All pilots have to be already registered for the 2 races at the first Team Captain's Meeting (TCM).

The replacement athlete must hold a valid IBSF International License.

10.6 The Race

10.6.1 Race Heats

An IBSF race can be held over 2 or 4 heats.

a) 4-Heat Races

In principle, the Olympic Winter Games and the Senior World Championships are held over 4 race heats. A reduction in the number of heats is possible in cases of force majeure. A minimum of two runs shall be required to award the title.

b) 2-Heat Races

The Continental Championships, the Junior World Championships and all other official IBSF races are held over 2 heats. All teams entered in the draw must conduct at least one race heat for the race to be officially valid.

10.6.2 Starting Order

Starting order for 2-heat races:

1st race heat: From 1 to the end

2nd race heat: From 20 to 1, according to the ranking of the first race heat

Starting order for 4-heat races:

1st race heat: From 1 to the end

2nd race heat: From 20 to 1 and from 21 to the end, according to the ranking of the first race heat

3rd race heat: From 1 to the end, according to the ranking after two race heats

4th race heat: From 20 to 1, according to the ranking after three race heats

10.6.3 Starting Order System

To hold a race, a minimum of 6 teams from a minimum of 2 nations must participate.

- Olympic Winter Games, Senior World Championships and Junior World Championships

The pilots will choose their start numbers according to their IBSF ranking.

The leading pilot in the IBSF ranking list by discipline will have the first choice, the second ranking the second choice and so on.

At the end of the distribution procedure – in the case of an external distribution of the starting numbers - the Jury will assign a starting number among those left to those athletes who were absent during the official distribution of the starting numbers

In the case of an internal distribution of the starting numbers (Team Captain Meeting) the starting number may also be chosen by the team captain.

- Continental Championships, World Cup, Intercontinental Cup, Europe Cup and North American Cup.

The season starts on the basis of the IBSF Discipline Ranking List from the previous season. The 10 best-placed pilots in the current IBSF Ranking List who are present are drawn. All other pilots start according to the ranking in the current IBSF Ranking List.

Teams without points are drawn at the end of the field.

The Jury holds the draw in public. An electronic draw by computer is possible. The pilots keep their start numbers for the duration of the competition.

10.6.4 Start Number

The Organiser supplies the teams with the start numbers. The size of the number should be approximately 40 cm².

The start numbers must be affixed according to the instructions of the Jury on the left side next to the pilot's push bar. They cannot be modified.

10.6.5 Teams and Manner of Driving

All race heats must be run with the same team.

In cases of injury or illness and with the permission of the Jury, an athlete may be replaced with an athlete from the same National Federation, with the exception of the pilot. The request for replacement shall be made in writing by the team captain. A medical certificate from the team doctor or the Race Doctor shall be enclosed or shall be given subsequently as soon as possible, as the case may be.

The Race Doctor and the Jury are authorized to prohibit athletes in inadequate mental or physical condition from competing. Only driving from the sitting position is allowed.

After a crash, the entire team must cross the finish line together with the sled. If the sled should come to a stop before the finish line, the team is disqualified. The help from third party is not permitted.

10.6.6 Track Conditions During the Race

The track is prepared after agreement among the Jury, the Race Director and the Chief of Track.

In case of snowfall, it shall be made certain that a regularly scheduled race is possible. Particular attention shall be paid to the ice surface at the start up to the start time measurement (50 m), which shall be swept prior to the start of each sled. In particular, the start grooves are to be swept. The track must be swept regularly. The race director must prepare a written protocol for sweeping in consultation with the Jury. The written protocol has to be announced no later than the final Team Captains Meeting

10.6.7 Track Walks

The times for the track walks are determined after agreement between the Race Director and the Jury, and are disclosed at the first team captains' meeting. Track walks are not allowed outside of these times. Entering the track during a run is absolutely prohibited.

There are no track walks on race days.

10.6.8 Start

The start block may be stepped upon during the start procedure, but the rear edge may not be crossed.

The start line (the first timing point) must be clearly visible.

The entire team shall be present after the call to the start.

The starter clears the track by means of acoustic and optical signals. The team at the start must activate the timing device within 60 seconds.

The athletes can accelerate the sled by pushing it.

The help from the third party during the start procedure is prohibited.

10.6.9 Reduction

If the number of registered teams exceeds the capacity of the track, the Jury, in agreement with the Technical Delegate and with the Race Director, can reduce the number of participants.

All registered teams must be allowed to compete in the first heat.

The number of teams can be reduced before each subsequent race heat.

The starting order does not change in such a case.

10.6.10 Interruption or Cessation

The Jury, in consultation with the Technical Delegate, the Race Director and the Chief of Track, can interrupt or stop the race for the following reasons, among others:

- Damage to the track
- Weather conditions
- Failure of the timing system or other technical equipment

After an interruption, the team at the start shall be granted a suitable amount of preparation time.

10.6.11 Repetition of a Heat

After a malfunction not caused by the team, the heat may be repeated with the authorization of the Jury.

The run may be repeated as soon as the team is ready to start.

10.6.12 Replacement Races

If a race is cancelled, the IBSF Executive Committee can decide to hold a replacement race at a later date on the same or a different track.

The following teams may participate in the replacement race:

- All teams eligible to participate, if the race concerned was cancelled prior to issuing the start numbers, or
- Only those teams which have received a start number for the cancelled race. Another drawing of the start numbers is carried out.

10.6.13 Pilot Sleds

The Jury determines the number of pilot sleds. The Organiser is obliged to provide a minimum of three pilot sleds. Before 2-man bobsleigh races, only 2-man bobsleighs should be used. Before 4-man bobsleigh races, only 4-man bobsleighs should be used.

If the Jury decides there are an insufficient number of pilot sleds available, the Jury can appoint teams that are last in the starting order. These teams start immediately after the pilot sleds, and their pilot run is also scored as a race heat.

The race Organiser is fully responsible for the selection and composition of each pilot sled.

10.6.14 Time Measurement

The run time can be measured electrically or electronically. Two independently functioning timing systems must be in use. The times must be measured to 1/100th of a second.

Times equal to 1/100th of a second are given the same rank.

There must be five interval times shown.

The first interval time corresponds to the start time (50 m).

The next four interval times must be evenly distributed among the remainder of the track.

The Organiser shall print out all official times recorded during the training and the race and shall hand them out to the participating nations.

If two or more teams achieve the same time in the first, second or third heats, the starting order for these teams in the second, third and fourth heats respectively shall be determined according to the start number. In such a case, the team with the highest start number is the first to start.

If the number of participants is reduced prior to the final race heat, the eliminated teams remain in the results with their final ranking. If in the final heat a team crashes, does not start or is disqualified, they do not receive a final ranking. The remaining teams move up in the ranking list. The time measurements shall be handed over to the TD/Coordinator at the end of the competition.

10.7 Parc Fermé

A Parc Fermé should be implemented and adapted to the specific conditions of the respective track.

10.8 Material and Equipment

10.8.1 Sled

In principle, all race heats must be contested with the same sled. If the sled has been damaged beyond immediate repair, a replacement sled may be allowed with the authorization of the Jury.

10.8.2 Runners

In all official IBSF races listed on the IBSF-Calendar (OWG, World Championships, Junior World Championships, Continental Championships, WC, ICC, EC, AC, IR) only IBSF standard runners (standard material) are admitted. The authenticity of the runner steel may be controlled by the IBSF Jury and/or IBSF Materials Inspectors at any time. To define the authenticity of the runner steel, inspections may include the analysis of the composition of the runner material and examination of the hardness of the runner steel.

Only geometrical changes to standard IBSF runners through the removal of the original material are allowed. No materials may be added in any way.

The use of any means of propulsion is prohibited.

Changing runners between race heats held on the same day is only permitted after damage and with the authorization of the Jury.

At the Jury's discretion, runners can be subjected at any moment to inspection with special equipment. In case of inconclusive findings, runners may be seized and sent to a specialized laboratory for further testing.

10.9 Technical Inspections

The sleds participating in the race must be in the start area, positioned in the spaces assigned to them. All preparatory work performed on the sleds, including mounting the runners, must be completed 45 minutes before the start of the race.

The sleds must be turned upside down and uncovered so that the runners face upwards.

After this time point, no work may be performed on either the sleds or the runners. Changing runners and replacing sled parts is also prohibited.

The runners may be polished between the race heats. Only the athletes belonging to the team from the sled concerned may perform the work.

After the last sled has been brought back to the start, there must be a break of a minimum of 5 minutes before the next race heat begins.

The runners can only be polished using abrasives provided by the IBSF

The runners must remain mounted on the sled. The use of any other materials and / or products is prohibited. Violation of this rule is penalized with immediate disqualification from the race.

The Jury can at any time confiscate the abrasives provided by the IBSF, regardless of whether they have been used or not.

Only the Jury, in agreement with the IBSF Materials Committee, can give authorization for repair work to be performed on sleds with technical problems.

Between the individual race heats, no further work may be performed without the authorization of the Jury.

If a set of runners is so damaged during a race that immediate repair is not possible, the team has the possibility to use a new set of runners, after receiving the authorization of the Jury. The new set of runners is subject to the provisions of the IBSF International Rules.

All sleds and runners participating in the race can be subjected to technical inspections. The Jury decides which sleds and runners are to be inspected and when the inspection is to take place. Inspections of the other equipment can also be conducted. The Jury can assign the members of the IBSF Materials Committee to carry out these inspections.

In cases of suspicion, components of the sled can be confiscated and subjected to technical inspections. The inspections can be conducted at a mobile laboratory on the competition site. In this case, the Jury evaluates the laboratory results immediately and takes the appropriate action.

If the technical inspections are conducted after the race at a laboratory outside of the competition site, the inspection results are forwarded to the IBSF Executive Management Committee. The laboratory in question must be approved by the IBSF. The procedures used must be in accordance with the Appendix attached to these Rules.

In case the results show proof of a violation against the IBSF International Rules, the IBSF Executive Committee takes the appropriate action. In this case, the National Federation concerned shall bear the costs of the inspection and appraisal. The decisions of the Executive Committee are incontestable.

If it is determined that the IBSF International Rules have been violated, then it automatically results in disqualification from the competition concerned.

10.10 Runner Radius

The Jury or the IBSF Materials Committee checks the radius of the runners with official IBSF gauges. The radius of the runners may not be less than that of the gauge.

10.11 Measurement of Runner Temperatures

The runner temperatures are checked before the start according to the instructions of the Jury. All four runners are checked with an electronic measuring device equipped with a temperature measuring sensor and a display device for temperatures between at least +30° C and -20° C.

The Organiser must provide two electronic measuring devices, one for the Jury and one for the teams participating in the race.

The temperature of the runners is measured on the side of the runner in the area of the middle supporting bracket. The measuring sensor shall remain in contact with the runner until the display on the temperature measuring device is stable.

The temperature of the runners that are mounted on the sled being used in the race may exceed the temperature of the reference runner by a maximum of 4° C. If the temperature of the reference runner is less than -14° C, the runners on the sled may have a maximum temperature of -10° C. If a team's runner temperature exceeds the limit, another measurement of the temperature of the reference runner and of the runner on the sled shall be made immediately following the first measurement. If the second measurement also shows a temperature that exceeds the limit, it leads to immediate disqualification. This is then registered in the Temperature Measurement Protocol.

The temperature listed on the official display will not be updated. The update will be done every 15 minutes (Art. 10.12).

The sled must be moved from its assigned place in the start area to the runner temperature measurement station by carrying it or by pushing it on its side on the bumpers. Cooling down the runners by touching them with snow or ice is not allowed.

10.12 Reference Runner

The temperature of the reference runner is measured according to the following procedure.

- a) The reference runner must be hung or otherwise positioned in the open air one hour before the start of the race, in the same climactic weather conditions as the sleds included in the race. When the reference runner is positioned in the open air, it must show a temperature of between +18° C and +22° C.
- b) The exact temperature of the reference runner at the time it was positioned in the open air must be written on a clearly visible board in the start area. The board must also show the air and ice temperatures.
- c) The temperature of the reference runner is measured on the side of the runner in the area of the middle supporting bracket.
- d) The temperatures shown on the temperature display board are updated as follows:
 - The first time, 60 minutes before the start of the race;
 - 10 minutes before the start of the race and before the start of the second heat
 - Afterwards, every 15 minutes
 - In the case of extraordinary climactic conditions (high temperatures), after measuring the runner temperatures the Jury can instruct the teams to place their sleds on the snow or ice immediately before the start.

10.13 Runner Cleaning

The runners are treated and cleaned before the start of the race heats with special cleaning solutions provided by the IBSF.

In every race in which the IBSF standard material is required, all runners are sanded with sandpaper in the same manner. It must be obvious that a characteristic amount of material has been removed. If

this is not the case, the procedure is repeated until sufficient material will have been removed; upon request of the Jury sandpaper with a bigger grain size may be used.

The sandpaper grade is determined by the IBSF before the start of the season.

On certain tracks and with certain motives the Jury may decide on a different grade of the sandpaper.

10.14 Weight

The weight is checked using a scale.

Weights can be checked at any time upon decision of the Jury.

The sled and the crew shall be weighed immediately after the conclusion of the race heat, upon request of the Jury. No modifications to the sled or the other equipment may be made. The team shall be inside the sled during the weighing procedure. The first weight test is then made. Each team may request a second weight test, if necessary. For the second test, they have a maximum of 5 minutes to remove snow and ice from the sled. This occurs under the supervision of the Jury.

The observed weight must be registered in the Weight Protocol.

Assistance by a third party is not allowed.

If an athlete needs to be replaced in between heats the team may reduce the ballast weight. Ballast weight may not be added.

Minimum Weight:

Sled including the runners and without the crew:

2-man bobsleigh: 170 Kg

Women's bobsleigh 165 Kg

4-man bobsleigh: 210 Kg

Maximum Weight:

Sled including the crew, the runners and the other equipment:

Men's 2-man bobsleigh: 390 Kg

4-man bobsleigh (Men and/or 630 Kg

Women):

Women's bobsleigh: 325 Kg

The maximum allowable weight can be reached by attaching ballast weights. The ballast weights must be firmly bolted or clamped to the sled.

10.15 Electronic Measuring Devices and Equipment

In the time during which the track is subject to the control of the IBSF (official training and races), no electronic or electrical measuring devices or equipment legalized by the IBSF may be used on the sled, on the team or on the track.

TV cameras belonging to the official producer are not subject to this article.

In cases of exception, the IBSF or the Jury concerned can allow specific measurements. In these cases, all the participants must be made aware of the results of the measurements.

10.16 Other Equipment

10.16.1 Helmet

During training runs and race runs, all athletes must wear a full-face helmet that conforms to ECE, OKM or DOT safety standards, and is commercially available in specialty shops. No aerodynamic elements may be additionally attached to the helmet.

It is the duty and the responsibility of the National Federations to comply with the safety standards.

10.16.2 Shoes

The use of spikes on the shoes of the athletes is allowed for pushing the sled, as long as the spikes are arranged in brush form.

The maximum diameter of the spikes may not be greater than 1.5 mm, the spikes may not be longer than 5 mm and the minimum amount of spikes per shoe must not be less than 250.

10.16.3 Clothing

Training and race suits with short pants and short sleeves are not allowed.

No aerodynamic elements whatsoever may be attached either outside or under the race suit.

Race suits must be manufactured from an uncoated textile.

10.17 Awards

10.17.1 IBSF Championships

At official IBSF Championships, the IBSF awards gold, silver and bronze medals to the athletes of the first, second and third placed teams. The athletes of the fourth, fifth and sixth placed teams receive commemorative medals. The Organiser awards additional honorary prizes to the teams.

10.17.2 Official IBSF Competitions

The Organiser awards honorary prizes to the athletes of the first through sixth placed teams.

10.18 Awards Ceremony

The awards ceremony should take place as soon as possible after the deadline for submitting protests.

The doping controls and technical inspections may also take place after the awards ceremony.

At all IBSF Championships and official IBSF competitions, the national flags of the first three placed teams must be hoisted. The national anthem of the winning team must also be played.

10.19 Protests

Protests must be made verbally to the Jury immediately or at the utmost 5 minutes after the heat in which that incident happened. Additionally, the grounds for the protest must be submitted in writing to the Jury no more than 20 minutes after the conclusion of the race.

If no verbal declaration of protest is made, no written protest may be subsequently submitted. Only the team captain may submit verbal and written protests. Collective protests are not allowed.

No protests are accepted after the submission deadline passes.

A fee in the value of €100 shall be paid with the submission of the written protest. If the protest is rejected, the fee is forfeited in favor of the IBSF. Otherwise, the protest fee is returned.

The decision regarding a protest submitted during a race shall be made in a timely manner to allow the team affected by the protest to potentially continue to participate in the race.

In cases of protests submitted after the conclusion of the race, the Jury will announce its decision no more than one hour after the submission of the protest, if possible.

The decision of the Jury is determined by a simple majority of votes. If the votes are equal, the Jury President casts the deciding vote. Jury Assistants do not have the right to vote.

The decision of the Jury is final, incontestable and takes effect immediately.

11. RANKING LISTS

11.1 Ranking List of the Race Series

For the World Cup, Intercontinental Cup, North American Cup and Europe Cup races, there are overall ranking lists issued at the end of the season and the first, second and third placed teams of each series

receive awards. In men's bobsleigh; the first 3 pilots in the Combined IBSF Ranking List ranking of each respective series also receive awards.

11.2 IBSF Ranking List

During the current season, the best results of each pilot are totalled by name for the IBSF Ranking List, regardless of the race series or World Championships in which the results were scored. It is consulted as an adjusted ranking list to determine the various quotas. The "juniors" are highlighted. For men's bobsleigh, there is an IBSF Ranking List for the 2-man competition, another for the 4-man competition, and a Combined IBSF Ranking List. For the "women" there is only the Ranking List for the two-man bobsleigh competition.

The number of races scored is equal to the number of World Cup races carried out up to that specific date during the current season.

The IBSF Ranking List is updated weekly, at the latest on Tuesday of each week. The World Cup ranking is updated immediately after each race.

The IBSF Discipline Ranking List (2-man bobsleigh and 4-man bobsleigh) serves to determine the starting order for the World Cup, Intercontinental Cup, North American Cup and Europe Cup races of the current season as well as for the first competition for each Series of the following competition season. If the ICC, NAC and or EC start before the WC the current ranking list of the corresponding series will be used to determine the starting order (updated once weekly from the second week on, at the latest on Tuesday of each week).

The IBSF Discipline Ranking List serves to determine the nation quotas and the starting order for the Olympic Winter Games and the World Championships.

The Combined IBSF Ranking List is meant to determine the Quota per Nation for the World Cup and the InterContinental Cup of the following competition season.

During the Senior World Championships the World Cup Points Table is applied, for the Junior World Championships the new ICC Points Table according to Appendix "A" is adopted.

The top-ranked teams of a nation determine the nation quotas for the World Cup competitions, and the next-ranked teams determine the quotas for the Intercontinental Cup competitions.

If a pilot sits out for a season, he is scored with 50% of his points achieved on the IBSF Ranking List for the first race of the following season.

In cases of equal points, the following decision criteria apply for all Ranking Lists:

- a) First, the highest single point score;
- b) Next, in the event of a draw, the better scores at the race immediately previous. (World Cup points are of higher priority than points obtained in the other race series)

12. FINAL CLAUSES

12.1 Coming into Force

This edition comes into force on October 1, 2015.

12.2 Modifications

The IBSF Executive Committee determines modifications to the IBSF International Rules.

12.3 Interpretation

If an article in these Rules should be ambiguously defined so that multiple interpretations are possible, the interpretation should be used that matches the underlying meaning for which the article was written.

13. APPENDIX 1: IBSF RANKING LIST "A"

WC and WCh.		JWCh.		NAC/EC		NAC/EC	
Rank	Points	Rank	Points	Rank	Points	Rank	Points
1	225	1	120	1	120	1	50
2	210	2	110	2	110	2	38
3	200	3	102	3	102	3	28
4	192	4	96	4	96	4	20
5	184	5	92	5	92	5	13
6	176	6	88	6	88	6	8
7	168	7	84	7	84	7	5
8	160	8	80	8	80	8	
9	152	9	76	9	76	9	
10	144	10	72	10	72	10	
11	136	11	68	11	68		
12	128	12	64	12	64		
13	120	13	60	13	60		
14	112	14	56	14	56		
15	104	15	52	15	52		
16	96	16	48	16	48		
17	88	17	44	17	44		
18	80	18	40	18	40		
19	74	19	37	19	37		
20	68	20	34	20	34		
21	62	21	31	21	31		
22	56	22	28	22	28		
23	50	23	25	23	25		
24	45	24	22	24	22		
25	40	25	20	25	20		
26	36	26	18	26	18		
27	32	27	16	27	16		
28	28	28	14	28	14		
29	24	29	12	29	12		
30	20	30	10	30	10		

14. Bobsleigh Constructions

General

The contents of the text are binding; the dimensions indicated in the drawings, diagrams and figures are compulsory.

Both the terms „bobsleigh“ and „bob“ are used to denote the same system of frame, cowling and runners.

14.1 Principles and Properties

14.1.1 Purpose of the Rules of 14.1

The purpose of the rules of chapter 14 is to promote the safety of the athletes participating in training and competition and of those present at IBSF events and to uphold a fair and honest competition.

14.1.2 Principles

- 1) Bobs have four runners (one pair of front runners and one pair of rear runners) and are used in competitions that are carried out on iced tracks.
- 2) To propel the bob, only the pushing force of the team, when starting and the force of gravity are allowed.
- 3) Two types of bobs are recognized: Two-men bob and Four-men bob.
- 4) Bobs must be cowed within the guidelines specified by these rules.
- 5) The rear part of the bobs must be open.
- 6) From the start (green light signal), no specifications of the bobs may be changed (damages excluded).
- 7) The driver's and side push bars must be fully retracted. Non-compliance may be punished.
- 8) It must be possible for the Jury or IBSF Materials Committee to check the specifications of all constructive elements (axles, runner carriers, steering mechanism, articulation mechanism, etc.) without great technical effort.
- 9) During the course of IBSF events, the Jury may order checks on bobs and sports equipment.
- 10) The bob manufacturers are responsible for the construction of sleds that can withstand, without damage, the stress of repeated runs on the bob tracks.
- 11) For building bobs, it is forbidden to use transparent material, or any material that may shatter as a result of an impact.
- 12) For the purpose of the IBSF, the term “steel” means an alloy of iron and carbon with an iron (Fe) content of more than 50% by weight, or an alloy that reacts positively to the IBSF chemical test.
- 13) No electronic, electric, electronically activated or wave activated components are allowed on the bob or the crew during official training or competition. The exceptions are those components approved by the IBSF and the relevant Jury.
- 14) With the exception of liquids or liquid-like fluids used for the purpose of lubricating the bearings and bushings of the frame, no liquids or liquid-like materials may be held in the frame or cowling or may in any way be attached to the frame or the cowling during an official IBSF event.
- 15) For the purpose of the IBSF, the terms rubber and/or rubber-like material mean a resilient material showing a hardness of less than Shore-D 100 on the ASTM D2240 Durometer test.

14.1.3 Bobsleigh Properties

14.1.3.1 Bobsleigh Weights

Minimum weight and maximum weight of the bobs are limited. The following is allowed:

- 1) Minimum weight (bob including runners, excluding the crew):
 - Two-men bob: 170 Kg
 - Women's bob: 165 kg
 - Four-men bob: 210 Kg
- 2) Maximum weight (including crew members and equipment required):
 - Two-men bob: 390 Kg;
 - Four-men bob (Men and/or Women): 630 Kg;
 - Women's bob: 325 Kg

14.1.3.2 Bobsleigh Functional Dimensions

The following main dimensions and constructive elements of the bobs are fixed. All dimensions refer to bobs without any load on a flat surface, if not specified to the contrary.

14.1.3.2.1 Gauge (centre to centre of opposite runners).

The gauge is the same for the front and rear runners, 670 mm \pm 1 mm.

14.1.3.2.2 Axle base

Distance from the centre of the front axle to the centre of the rear axle (referred to the plane of symmetry of the bob): 1690 mm \pm 30 mm (two-men bob); 2130 mm \pm 30 mm (four-men bob).

14.1.3.3 Bobsleigh Miscellaneous Properties

14.1.3.3.1 Bobsleigh Suspension

There must be no rubber, rubber-like or energy absorbing materials in the runner carriers, frame and / or all other parts of the bob, apart from those specifically allowed by the IBSF rules.

14.1.3.3.2 Bobsleigh Brakes

All bobs must be equipped with a functioning braking system (Figure 20).

14.1.3.3.3 Ballast

- 1) Weight limit may be achieved by means of ballast. If for this purpose, ballast is used that is not firmly welded, bolted or clamped to the frame by steel fasteners, it must be contained in a steel hollow profile. The size of any closed steel profile serving as a container for ballast weight is limited to a cross section of 50 x 50 mm and a length of maximally 400 mm. The use of tape or plastic straps for the purpose of attaching ballast to the frame or cowling is prohibited.
- 2) No liquids or liquid-like materials may be used as ballast materials.

14.2 Bobsleigh Construction and Functioning

14.2.1 Purpose of Rules of 14.2

The purpose of the Rules governing the construction and functioning of the equipment used is to promote that the equipment used in IBSF events is able to withstand the stresses of training and competition and that the equipment used provides adequate protection for those using the equipment. Furthermore, the paragraph 14.2 aims to promote a fair and honest competition. Finally 14.2 is directed at controlling the cost of competing in IBSF events.

14.2.2 General Structure and Functioning

14.2.2.1 Articulation

14.2.2.1.1 Transversal Division

Every bob frame must be divided transversally between front axle and rear axle.

14.2.2.1.2 Pivotal Connection

- 1) The front portion and the rear portion of the bob are pivotally connected, the longitudinal pivot axis (2) being essentially parallel to the horizontal standing surface (1).
- 2) The angle between said longitudinal pivot axis (2) and the horizontal standing surface is must not exceed 5°.

14.2.2.1.3 Longitudinal Pivot Axis

- 1) The longitudinal pivot axis (2) is embodied by a longitudinal pivot bolt (3) of steel, having a middle circular cross-section with a minimum diameter of 30 mm (two-men bob) and 35 mm (four-men bob) that may taper to the ends to a minimum diameter of 21 mm (two-men bob) and 31 mm (four-men bob).
- 2) By means of said bolt (3), both bob portions are pivotally connected.
- 3) The pivot bolt (3) may have means of rotational elastic stabilization. For this purpose, rubber or rubber-like material may be used. These stabilizing elements must not contribute to any vertical movement. No hydraulic or pneumatic damping system is allowed.
- 4) If the pivot bolt (3) ahead or behind the division is enclosed by a box, each box must have a 20 mm diameter inspection hole accessible from the top.
- 5) At the dividing line, the longitudinal centerline of the longitudinal pivot axis (2) must be arranged at least 80 mm (two~ and four-men bobs, without crew and supported on runner carriers) above the standing surface.
- 6) The dividing line must be at a distance of 520 mm \pm 50 mm (two~ and four-men bobs) behind the centre of the front axle

14.2.2.1.4 Cowling division

The cowling must also be divided transversally. Rubber or rubber-like material may be used to cover the gap between the front and the rear parts of the cowling.

14.2.3 Frame and Running Gear

14.2.3.1 Purpose of the Rules of 14.2.3

The purpose of paragraph 14.2.3 is to control the sturdiness of the frame in the interest of safety and, in the interest of competition to control the amount of suspension provided to bobsleigh.

14.2.3.2 General Stipulations Frame

- 1) All joints in the frame must be rigid.
- 2) The front (4) and rear (31) frame must not be adjustable in stiffness during heats or between heats.

14.2.3.3 Front Portion of the Frame

- 1) The front portion of the bob must be constructed with a continuous (welded) supporting frame (4) made of steel and extending from the longitudinal bolt (3) at the transversal division line to the bearing housing of the steering bolt (5). All load bearing frame members and the bearing housing(s) of the steering bolt (5) and the bearing housing(s) of the longitudinal bolt (3) bolt must be welded to the frame.
- 2) The swivel angle of the front axle (9) (two~ and four-men bobs) in the vertical plane (referred to the standing surface) is limited to maximally $\pm 12^\circ$
- 3) The distance from the centre of the front axle (9) to the front tip of the bob is limited to: minimally - 600 mm (two~ and four-men bobs) and maximally - 750 mm (two~ and four-men bobs)
- 4) If the frame members and connecting profiles are made of tubing, they must remain hollow with no filling and have an inspection hole with a minimum diameter of 8 mm.

14.2.3.3.1 Steering mechanism

- 1) A rotating steel steering bolt (5) is fitted to the front frame (4) and rotates by means of a steering mechanism. The said steering bolt must not exceed 5° from vertical.
- 2) The bearing housing of the steering bolt must be completely welded to the frame, on all sides.
- 3) The lower end of the steering bolt is completely welded perpendicular to a steel steering plate (6) with a minimum thickness of 7.5 mm throughout the surface of the plate and a minimum width of 69 mm over half its length (two~ and four-men bobs). A central welding access hole is allowed.
- 4) On this steering plate (6), at a bolt (7) lying in front of the axle (9) and at a bolt (8) lying behind the axle (9), steel flanges (11a and 11b) are pivoted on a pivot axis (10) that is perpendicular to the front axle (9) and perpendicular to the steering bolt (5).
- 5) The minimum diameter of the bolts (7 and 8) must be 20 mm.

- 6) There must be no vertical motion between the fixed bearing and the rotating support.
- 7) A continuous, one-piece steel bottom plate (14) is mounted below the axle (9) with a minimum thickness of 7.5 mm (two~ and four-men bobs) throughout the surface of the plate and a minimum width of 69 mm (two~ and four-men bobs). On each end of the plate for a length of 20 mm a chamfer or rounding is allowed.
- 8) The bottom plate (14) is firmly bolted (15), with no free play, to both steel flanges (11a, 11b).
- 9) An intermediate layer (20) of rubber or rubber-like material, a maximum of 3 mm thick, may be placed between the respective flanges (11a, 11b) and the bottom plate.
 - a) The thickness of the rubber or rubber-like material is to be measured after having been removed from the sled.
 - b) For any further compensation, only steel and / or aluminum shims may be used.
- 10) The free length of the bottom plate (14) between the two flanges (11a and 11b) in the longitudinal direction of the bob is 220 mm \pm 40 mm (two~ and four-men bobs).
- 11) The flanges (11a and 11b) can be provided with U-shaped guiding elements.
- 12) For the purpose of returning the runners in a neutral position, rubber or rubber-like materials may be used in the steering mechanism.

14.2.3.3.2 Front Axle

- 1) The front axle (9) consists of a continuous, straight, circular steel tube manufactured from a single piece of steel having an outer diameter that is a minimum of 44 mm (two~ and four-men bobs), which reduces to a minimum of 32 mm (two~ and four-men bobs) to fit the bearing of the front runner carrier (17).
- 2) The 44 mm diameter portion of the axle must have a minimum wall thickness of 9 mm and a minimal length of 450 mm.
- 3) In its middle portion, the front axle (9) has a steel fastening plate (18) of no less than 7.5 mm in thickness that must be strongly welded (not screwed) to it and firmly bolted to the bottom plate (14).
- 4) Steel spacers are allowed between the axle fastening plate and the bottom plate.
- 5) The fastening plate (18) may be recessed flush to the circumference of the front axle (9).
- 6) A steel plug may be welded or pressed into each end of the axle (9) to provide attachment for the runner carrier retainer.
- 7) If a steel plug is used in the end of the axle, it must have a 6.5 mm through-hole.
- 8) The front axle (9) must not be clad, cased or streamlined.

14.2.3.3.3 Front Axle Leaf Spring

- 1) Between the steering plate (6) and the front axle (9) there is a continuous steel leaf spring (19) with a minimum thickness throughout of 6 mm.
- 2) The points at which the leaf spring (19) rests on the front axle (9) must be symmetrically at least 330 mm from each other (two~ and four-men bobs).
 - a) The leaf spring can be made of three pieces.
 - b) The brackets must have an axial width of min. 12 mm. The brackets must be screwed with a minimum number of two M8 screws.
 - c) The radius of the brackets will not be limited.
 - d) No additional spacers are allowed.
 - e) Brackets must be made of steel.
- 13) When the axle is in a neutral position, there must be no free play between the leaf spring (19) and the steering plate (6) or between the leaf spring (19) and the axle (9).
- 14) No spacers are allowed between the leaf spring (19) and the steering plate (6) or between the leaf spring (19) and the axle (9).

14.2.3.3.4 Front Runner Carriers

- 1) Each front-runner carrier consists of a straight steel spring leaf (17) with a thickness of no less than 7.5 mm throughout (two~ and four-men bobs).

- 2) The distance from the standing surface of the front runner carriers to the axle centre is limited to maximally 100 mm.
 - 3) A bearing housing (16) for the front axle (9) must be welded to the upper side of the spring leaf (17).
 - 4) On the lower part of the spring leaf (17) there will be a guiding bracket (21) welded in the centre.
 - 5) On either end of the spring leaf (17) there will be holding brackets (22 and 23) welded in position.
 - 6) The bearing housing (16) has a minimum outside diameter of 50 mm (two~ and four-men bobs) and a maximum outside diameter of 55 mm (two~ and four-men bobs).
 - 7) The length of the bearing housing (16) is no less than 94 mm (two~ and four-men bobs).
 - 8) The hole in the bearing housing (16) must be concentric with respect to a horizontal diameter.
 - 9) The distance from the outer end of the bearing housing (16) to the straight outer edge of the front-runner carrier (17) must not exceed 6 mm.
 - 10) As seen in the top view, the outer side of the front-runner carrier (17) must be straight and perpendicular to the axle (9); the outer side of the spring leaf and guiding bracket must essentially fall above one another. (No offset is allowed.)
 - 11) The length of the front-runner carrier (17) is 655 mm \pm 3 mm (two-men bob), 735 mm \pm 3 mm (four-men bob).
 - 12) The width of the front-runner carrier (17) must be no less than 35 mm (two~ and four-men bobs) at the front and rear ends and must increase towards the centre to its maximum width, which must be no less than 69 mm (two-men bob) and no less than 89 mm (four-men bob).
 - 13) In a top view, the inside edge of the front-runner carrier (17) facing the cowling must not be concave.
 - 14) The front and rear holding brackets (22 and 23) have a U-shaped cross section, where the "bridge" of the U is welded to the runner carrier (17) and has a minimum thickness of 7.5 mm.
 - 15) The two U legs extend vertically downward with a height of 50 mm \pm 2 mm. The outside dimensions of the U legs are 30 mm \pm 2 mm.
 - 16) The length of the holding brackets (22 and 23) is 70 mm \pm 2 mm.
 - 17) The holding brackets (22 and 23) must be provided with runner mounting holes, the centre of which must be 31 mm \pm 1 mm from the lower side of the runner carrier (17). The runner mounting holes must be symmetrical within 1 mm to the front and rear of the holding brackets (22 and 23).
 - 18) Only the holes (24 and 25) for the head of the bolts may be countersunk.
 - 19) The hole centers of the front and rear holding brackets (22 and 23) have a centre distance of 585 mm \pm 2 mm (two-men bob) and 665 mm \pm 2 mm (four-men bob).
 - 20) The middle guiding bracket (21) has the same dimensions as the holding brackets (22 and 23), with the exception that the U legs are connected by welded metal straps, front and rear, to hold a layer of rubber or rubber-like material at the bottom of the U (26).
 - 21) The middle guiding bracket (21) may be additionally supported to the spring leaf.
 - 22) The centre of the bearing housing (16) may be a maximum of 5 mm out of symmetry between the runner mounting holes (two~ and four-men bobs).
 - 23) The runner carriers (17) must have a means of rotational elastic stabilization.
 - 24) If the rotational stabilization is mounted from the bottom of the runner carrier, the opening in the spring leaf may not exceed a length of 35 mm and must be within the welds of the bushing to the spring leaf.
 - 25) The front-runner carriers (17) must not be cased, clad, faired or streamlined.
 - 26) All edges of the spring leaf, guiding brackets (21) and holding brackets (22 and 23) may be radiused or chamfered to a maximum of 8 mm.
- #### 14.2.3.4 Rear Portion of the Frame
- 1) The rear bob portion must be constructed with a continuous (welded) supporting frame (31), made of steel and extending from the longitudinal pivot bolt (3) at the transversal division line to the

fastening means for the rear axle. All load bearing frame members and the bearing housing(s) of the longitudinal bolt (3) must be welded to the frame.

- 2) From the division line to the rear axle, the longitudinal frame members must be made of closed steel profile. The longitudinal frame members must have a minimum section area of 703 mm²; the largest dimension of the said frame member must be at least 37 mm. The smallest dimension of the said frame member must be at least 19 mm.
- 3) If the longitudinal members are made of tubing, they must remain open with no filling and have inspection holes with a minimum diameter of 8 mm located every 500 mm along the frame.
- 4) The minimum distance between the two longitudinal members of the rear frame will be 320 mm.
- 5) Where the axle is fastened to the rear frame, there will be a defined contact area between the axle mounts and the axle. In any case the contact area between the axle and each axle mount must be at least 700 mm².
- 6) In case the axle is fastened to the frame by means of bolts, full contact between the axle and the axle mounts must exist for a distance of a minimum of 15 mm around the fastening hole.
- 7) In case the axle is fastened to the frame by means of clamps, full contact between the axle and the axle mounts must exist over at least 150 degrees of the circumference of the axle and over a length of at least 25 mm.
- 8) The minimum distance between the outermost points of full contact between the axle and the axle mount will be 165 mm.

14.2.3.4.1 Intentionally left blank

14.2.3.4.2 Rear Axle

- 1) The rear axle (27) consists of a continuous, straight, circular steel tube manufactured from a single piece of steel having an outer diameter that is a minimum of 44 mm (two~ and four-men bobs), which reduces to a minimum of 32 mm (two-men bob) and 34 mm (four-men bob) to fit the bearing (28) of the rear runner carrier (29).
- 2) The 44 mm diameter portion of the axle must have a minimum wall thickness of 9 mm and a minimum length of 450 mm.
- 3) The rear axle (27) must be firmly bolted or clamped to the rear frame (31) without any resilient or shock absorbing material in between.
- 4) Steel spacers are allowed.
- 5) The rear axle (27) can be bolted either above or below the rear frame (31) (two~ and four-men bobs).
- 6) A steel plug may be welded or pressed into each end of the axle to provide attachment for the runner carrier retainer.
- 7) If a steel plug is used in the end of the axle, it must have a 6.5 mm through-hole.
- 8) The rear axle (27) must not be clad, cased or streamlined.

14.2.3.4.3 Intentionally left blank

14.2.3.4.4 Rear Runner Carriers

- 1) Each rear runner carrier consists of an upper and lower straight steel spring leaf (32 and 33) with a thickness of no less than 7.5 mm throughout (two~ and four-men bobs).
- 2) The vertical distance from the standing surface of the rear runner carriers to the axle centre is limited to maximally 110 mm.
- 3) A bearing housing (28) for the rear axle must be welded to the upper side of the upper spring leaf (32).
- 4) On the lower side of the lower spring leaf (33) there will be a guiding bracket (34) welded in the centre.
- 5) On either end of the lower spring leaf (33) there will be holding brackets (35 and 36) welded in position.
- 6) The bearing housing (28) has a minimum outside diameter of 50 mm (two~ and four-men bobs) and a maximum outside diameter of 55 mm (two-men bob) and 57mm (four-men bob).

- 7) The length of the bearing housing (28) is no less than 94 mm (two~ and four-men bobs).
- 8) The hole in the bearing housing (28) must be concentric with respect to a horizontal diameter.
- 9) The distance from the outer end of the bearing housing (28) to the straight outer edge of the upper spring leaf (32) must not exceed 6 mm.
- 10) As seen in the top view, the outer side of the lower spring leaf (33) must be straight and is essentially perpendicular to the axle (27); at the centre of the runner carrier, the outer side of the upper spring leaf (32), lower spring leaf (33) and guiding bracket must essentially fall above one another. (No offset is allowed.)
- 11) The length of the lower spring leaf (33) is 813 mm \pm 3mm (two-men bob) and 940 mm \pm 3 mm (four-men bob).
- 12) The width of the lower spring leaf (33) must be no less than 35 mm (two~ and four-men bobs) at the front and rear ends and must increase towards the centre to its maximum width, which must be no less than 79 mm (two-men bob) and no less than 89 mm (four-men bob).
- 13) In a top view, the inside edge of the lower spring leaf (33) facing the cowling must not be concave.
- 14) The front and rear holding brackets (35 and 36) have a U-shaped cross section, where the bridge of the U is welded to the lower spring leaf (33) and has a minimum thickness of 7.5 mm.
 - a) The two U legs must extend vertically downward with a height of 50 mm \pm 2 mm.
 - b) The outside dimensions of the U legs must be 30 mm \pm 2 mm.
- 15) The length of the holding brackets (35 and 36) must be 70 mm \pm 2 mm.
- 16) The holding brackets (35 and 36) must be provided with runner mounting holes, the centre of which must be 31 mm \pm 1 mm from the lower side of the spring leaf (33). The runner mounting holes must be symmetrical within 1 mm to the front and rear of the holding brackets (22 and 23).
- 17) Only the holes (35 and 36) for the head of the bolts may be countersunk.
- 18) The hole centers of the front and rear holding brackets (35 and 36) must have a centre distance of 743 mm \pm 2 mm (two-men bob) and 870 mm \pm 2 mm (four-men bob).
- 19) The middle guiding bracket (34) has the same dimensions as the holding brackets (35 and 36), with the exception that the U legs are connected by welded metal straps, front and rear, to hold a layer of rubber or rubber-like material at the bottom of the U (34).
- 20) The middle guiding bracket (34) may be additionally supported to the spring leaf (33).
- 21) The centre of the bearing housing (28) may be a maximum of 5 mm out of symmetry between the runner mounting holes (two~ and four-men bobs).
- 22) The upper spring leaf (32) is shorter than the lower spring leaf (33) and has a length of 480 mm \pm 3 mm (two-men bob) and 590 mm \pm 3 mm (four-men bob).
- 23) The minimum width at the front and rear ends of the upper spring leaf (32) is 40 mm and must increase towards the centre to its maximum width, which must be no less than 79 mm (two-men bob) and 89 mm (four-men bob).
- 24) In the top view, the upper spring leaf must have no concave edges.
- 25) The upper (32) and lower (33) spring leaves lie flat on one another and are bolted together by no less than 6 and no more than 8 bolts with hexagonal nuts.
- 26) There must be the same number of bolts on either side of the bearing housing (28).
 - a) Only the holes for the head of the bolts may be countersunk.
 - b) The minimum diameter of the bolts must be 12 mm (two-men bob) and 14 mm (four-men bob).
 - c) The minimum height of the hexagonal nuts must be 10 mm (two-men bob) and 11 mm (four-men bob).
- 27) The runner carriers (29) must have a means of rotational elastic stabilization. If the rotational stabilization is mounted from the bottom of the runner carrier, the opening in the spring leaf may not exceed a length of 35 mm and must be within the welds of the bushing to the spring leaf.
- 28) The runner carrier (29) must not be cased, clad, faired or streamlined.
- 29) All edges of the spring leaves (32 and 33), guiding brackets (34) and holding brackets (35 and 36) may be radiused or chamfered to a maximum of 8 mm.

14.2.4 Cowling

14.2.4.1 Purpose of 14.2.4

The purpose of paragraph 14.2.4 is to promote the safety of the athletes competing in IBSF events by attempting to ensure that the cowling of a bobsleigh will provide sufficient protection in case of crashes. Furthermore, the Rules of 14.2.4 aim to promote a competition without unfair aerodynamic advantages.

14.2.4.2 General Cowling Stipulations

- 1) It is not allowed to use any additional material on the cowling cut-out.
- 2) The brake cut-out must be open.
- 3) No attempt may be made to reduce the area of the cut-out with any material.
- 4) Any unusual additions to the shape that are clearly vortex generators are not allowed.
- 5) Additional holes that may give an improved aerodynamic effect are also not allowed.
- 6) The cowling provides adequate protection for the athletes.

14.2.4.3 Cowling Dimensions

14.2.4.3.1 Cowling Width, Two-men Bobsleigh.

The distance from the farthest point to the opposite farthest point (measured on the horizontal plane according to Figure 2 of the drawings) must be:

- At a distance of 1200 mm in front of the centre line of the rear axle: minimally - 680 mm.
- At a distance of 600 mm from the centre line of the rear axle: minimally - 640 mm.
- At the centre line of the rear axle: minimally - 540 mm.

14.2.4.3.2 Cowling Width, Four-men Bobsleigh

From the centerline of the rear axle up to a distance of 1600 mm in front of the centerline of the rear axle, a constant minimum width of 700 mm must be maintained.

14.2.4.3.3 Inside Cowling Width Two-men and Four-men Bobsleigh

Measured at a height of 400 mm from the bottom of the bob, at the beginning of the cowling cut-out, the inside cowling width must be minimally 550 mm (two-men and four-men bobsleigh).

14.2.4.3.4 Cowling Height

- 1) The driver's seat is defined as a flat horizontal area with a minimum radius of 90 mm.
- 2) The measurement is taken from whatever the driver is sitting on.
- 3) The vertical distance from the 90 mm radius-seating surface to the centre top of the cowling cut-out must be minimally 650 mm (two~ and four-men bobs).

14.2.4.3.5 Cowling Side Region

- 1) The side cowling, from the region of the driver's shoulders to the centre of the rear axle, must not be higher than 650 mm as measured from the bob bottom and must have a minimum height of 580 mm.
- 2) The cowling must be open – starting from the region of the driver's shoulders, through to the back.
- 3) The width of the opening, starting 500 mm behind the beginning of the opening to the rear axle centre, must be minimally 450 mm down to a depth of 300 mm (two~ and four-men bobs).
- 4) From the centre of the rear axle to the hindmost point of the bob, the width of the opening must be minimally 400 mm measured down to a point 300 mm above the lowest point of the bottom of the bob (two~ and four-men bobs).

14.2.4.3.6 Cowling Miscellaneous

- 1) From the highest part of the driver's cut-out, there must be a vertical flange as shown in Figure 4. The vertical flange must be a minimum height of 30 mm in the centre of the driver's cut-out. The flange may taper down to the thickness of the cowl over a distance of 100 mm on either side of centre.
- 2) The rectangular, symmetrical inspection hole situated beneath the front axle must be at least 440 mm long and at least 160 mm wide.
- 3) On either side, a rubber or rubber-like membrane may be used to close the gap between the front axle and the cut-out for the front axle.

- 4) On the top of the brake housing, a rubber or rubber-like membrane may be used around the handles.

14.2.4.4 Cowling Shapes

14.2.4.4.1 Purpose of 14.2.4.4

The purpose of paragraph 14.2.4.4 is to promote a competition without unfair aerodynamic advantages.

14.2.4.4.2 Convex Surfaces

- 1) The cowling shape must be convex with the following exceptions:
 - a) The bumpers (front and back)
 - b) The brake cut-out
 - c) The impression for the driver's push handle
 - d) The articulation joint
 - e) The holes for the front and back axles
 - f) The transition from the side push bar into the main body of the cowling (fig.7)
 1. if the pushbars are mounted directly to the top of the side of the main body of the cowling: From a vertical plane 450 mm forward of the axis of rotation and a height of 670 mm above the standing surface of the runner carriers.
 2. if the pushbars are mounted to a separate stanchion intersecting the main body of the cowling: In a radius of 400 mm from the center at the top of the axis of rotation of the push bar.
 - g) & h) The area around the brakeman's push handles that is within a radius of 250 mm from the point of the brakeman's push handles farthest removed from the centerline of the rear axle.
- 2) The following four specific areas will be controlled:
 - a) From the front of the bob to the driver cut-out, every intersection line between a rotating cutting plane and the cowling, refer to Figure 3A
 - b) From the front of the bob to the rear of the bob, every intersection line between the vertical cutting planes and the cowling above the widest point or at least above the bumpers, refer to Figure 3B;
 - c) From the beginning of the driver's cut-out to the rear of the bob, the intersection line between a horizontal cutting plane and the cowling, at a height of 350 mm above the standing surface of the runner carriers, refer to Figure 3C;
 - d) On the bottom of the bob, every intersection line between a longitudinal vertical cutting plane as well as every intersection line between a perpendicular vertical cutting plane and a 240 mm wide symmetric band centered on the bottom of the bob. Outside of the 240 mm band, the only exceptions would be the impressions created for the runner and the runner carrier clearance, refer to Figure 3D.

14.2.5 Connection between Frame and Cowling

14.2.5.1 Purpose of 14.2.5

The purpose of 14.2.5 is to control the amount of suspension that can be achieved in the connections between cowling and frame.

14.2.5.2 Definition of Connection between Cowling and Frame

All elements that mechanically attach the cowling as defined and controlled by 14.2.4 to the frame as defined and controlled by 14.2.3 are considered to jointly form the connection between cowling and frame and to be controlled by 14.2.5

14.2.5.3 General Stipulations

- 1) Any measurements with regard to travel of the cowling relative to the frame are relative to the horizontal plane of reference, with the bobsleigh in an unloaded condition.
- 2) Within the context of 14.2.5, the term 'downward' is used with reference to the unloaded condition of the bobsleigh while positioned on a horizontal reference plane.

3) Within the context of 14.2.5, the limitation of freedom of movement of the cowling relative to the frame is defined with reference to the unloaded condition of the bobsleigh while positioned on a horizontal reference plane.

4) Article 14.1.3.3.1 (Bobsleigh suspension) applies

14.2.5.4 Locations of points of mounting of Cowling to Frame

1) The cowling must be attached to the frame by means of at least four mounting brackets that to restrict the vertical movement of the cowling relative to the frame.

2) Two of these four mounting brackets must be positioned symmetrically relative to the plane of symmetry of the bob, in a vertical plane that is perpendicular to the plane of symmetry of the bobsleigh and within 100 mm of most forward part of the rear part of the frame excluding the articulation bolt (Figure 23).

3) Two of the four mounting brackets must be positioned symmetrically relative to the plane of symmetry of the bob and must be mounted on or to the outside of the longitudinal frame member. (Figure 23).

14.2.5.5 Freedom of Movement of Cowling relative to Frame

1) The movement of the cowling relative to the frame, allowed by the mounts of the cowling controlled by 14.2.5.4 and 14.2.5.6 must be limited to 5 mm in the downward direction by use of travel stops.

2) Irrespective of the suspension elements used within the context of 14.2.5.4 and 14.2.5.6, the travel of these suspension elements must be limited by hard travel stops of sufficient rigidity to guarantee effective limitation of cowling movement.

3) The forward travel stops limiting the vertical movement of the cowling must be fully positioned within the confines of 14.2.5.4. In case the travel stops are not an integral part of the mounting brackets, the forward travel stops must be completely positioned within 100 mm of most forward part of the rear part of the frame excluding the articulation bolt (14.2.5.4.2) (figure 23).

4) The rear travel stops must be mounted on or to the outside of the longitudinal frame member and completely within 120 mm forward and backward of the centerline of the rear axle. (14.2.5.4.3) (Figure 23).

14.2.5.6 Materials used in Cowling to frame Connection

1) In the mounts between the cowling and the frame, rubber or rubber-like material may be used.

2) The rubber or rubber-like material used in the connection between frame and cowling must be homogeneous.

14.2.6 Bumpers

14.2.6.1 Purpose of 14.2.6

The purpose of 14.2.6 is to attempt to ensure that the elements of the bobsleigh that come into contact with the walls of the track are suitable for that purpose. Furthermore, 14.2.6 aims to promote that no unfair aerodynamic advantages can be achieved. Finally art. 14.2.6. is directed to preserve the integrity of the track.

14.2.6.2 General Stipulations

It is the responsibility of the bob manufacturers to produce the bumpers with sufficient strength to withstand repeated contact with the walls.

14.2.6.3 Bumper Positions and Dimensions

1) The front tips of the front-runners must be covered by the cowling in any position of the runners.

2) Distance from the standing surface of the runner carriers to the lower edge of the bumpers is limited to:

- Front bumpers
 - maximally 190 mm (two-men bob);
 - maximally 200 mm (four-men bob);
- Rear bumpers
 - maximally 200 mm (two-men bob and four-men bob) .

- 3) The rear bumpers must have a minimum height of 50 mm (measurement taken vertically with regard to the standing surface) over a length of minimum 200 mm.
- 4) The centre of the front bumpers, referring to a length of 300 mm, must be at least 300 mm from the centre of the front axle (two~ and four-men bobs).
- 5) Above the front bumper 300 mm forward from the centre of the front axle, the distance from the outside of the bumper to the cowling, measured horizontally and perpendicular to the centre line of the bob, must not exceed 195 mm (two-men bob) and 160 mm (four-men bob), refer to Figure 2.
- 6) The distance from the farthest point of one bumper to the farthest point of the opposite bumper must be:
 - Front:
 - 860 mm \pm 10 mm (two-men bob);
 - 870 mm \pm 10 mm (four-men bob).
 - Rear:
 - Minimally 800 mm (two-men bob).
 - Minimally 830 mm (four-men bob).
- 7) The distance from the centre of the rear axle (27) to the hindmost point of the rear bumper must be:
 - Minimally - 300 mm (two~ and four-men bobs);
 - Maximally - 760 mm (two~ and four-men bobs).

14.2.6.4 Bumper Shapes

- 1) The upper and lower edges of the rear bumpers must have a radius of between 5 and 8 mm.
- 2) The lower edge of the front bumpers (Figure 5) must have a radius of no less than 10 mm for a minimum length of 300 mm. In an upward direction they must be straight for a minimum length of 35 mm, subsequently passing into the upper edge with a minimum radius of 35 mm.
- 3) The point at which the bumper contacts the wall must be within the defined minimum length of the bumper. In a top view, the bumpers must be arc-shaped with a minimum radius of 200 mm for a distance of 100 mm ahead and behind the widest part of the bumper area (Figure 6).

14.2.6.5 Transitions to Cowling

- 1) The connecting elements between the front bumpers and the bob cowling must have a height of a minimum of 80 mm over the minimal length of the front bumpers.
- 2) The connecting elements between the rear bumpers and the cowling must have a height of a minimum of 50 mm over the minimal length of the rear bumpers.
- 3) In a top view and in a side view the front of the connecting elements of the front bumpers must form a continuous, not concave line with the tip of the cowling.

14.2.7 Runners

14.2.7.1 Purpose of 14.2.7

Purpose of 14.2.7 is to promote a fair competition while controlling the costs of participating and administering in IBSF events by banning the use of exotic materials and (surface) treatments.

14.2.7.2 Runner material

- 1) All runners must be produced in a solid piece of standard material according to IBSF specifications.
- 2) The material specifications, selected by the IBSF, will guarantee that all pre-machined pieces of steel are the same.
- 3) The standard material is produced and distributed by a factory designated by the IBSF
- 4) The material is supplied in the form of a pre-machined section, i.e. a section that has been ground on both sides, one of which is marked.
- 5) The marking must always be present on the runners without being changed in any way.

14.2.7.3 Runner Treatment

- 1) All types of treatment are forbidden, including those that even cause only a local variation of the physical characteristics and / or the composition and / or the structure of the material.
- 2) No plating and / or coating is allowed.

14.2.7.4 Runner Dimensions

- 1) The height of the steel body, between the front and rear fastening brackets, must be a minimum of 35 mm (two-men bob) and a minimum of 40 mm (four-men bob).
- 2) The forward portion of the runner from 50 mm behind the tip to the front of the front fastening bracket must be no less than 30 mm high (two~ and four-men bobs).
- 3) The front tip of the runner, in the side view, must have a minimum radius of 10 mm (two~ and four-men bobs).
- 4) The top of the front-runner tip must be a minimum of 60 mm above the standing surface.
- 5) The rear lower tip of the runner must have a minimum radius of 50 mm (two~ and four-men bobs).
- 6) At a distance of 10 mm from the rear tip of the runner, the lower surface must be a minimum of 25 mm above the standing surface (two~ and four-men bobs).
- 7) The distance from the front tip of a front runner to the centre of the middle supporting bracket must be 500 mm \pm 30 mm (two-men bob) and 540 mm \pm 30 mm (four-men bob).
- 8) The overall length of the rear runners must not exceed 1200 mm (two-men bob) and 1300 mm (four-men bob).
- 9) The top surface of the middle supporting bracket must be flat and horizontal and must form a rectangle, minimum width 13 mm, minimum length 60 mm. The 60 mm dimension must be maintained down to the top of the runner.
- 10) The top of the middle supporting bracket must be a minimum of 15 mm above the top of the runner.
- 11) At the intersections of the middle supporting bracket with the top surface of the runner, there must be a minimum radius of 2 mm.
- 12) The runner must have a thickness of 14 mm \pm 1 mm (two~ and four-men bobs). This thickness must be maintained for a minimum distance of 10 mm from the top of the runner.
- 13) The cross-sectional radius of the runner, at the running surface, must be a minimum of 4 mm (two-men bob) and 6 mm (four-men bob). This radius will be measured over 120° and will correspond to an arc height of 2 mm (two-men bob) and 3 mm (four-men bob).
- 14) The fastening brackets must have a minimum length of 60 mm (two~ and four-men bobs) measured at a height even with the upper edge of the runner.
- 15) The area surrounding the mounting hole must maintain a minimum thickness of 10 mm to the periphery of the fastening bracket. The transition region, tangent to the radius, and extending to the full width portion of the runner, must not be concave.
- 16) The mounting holes are at a minimum distance of 33 mm and a maximum of 60 mm (two-men bob) and a minimum of 38 mm and a maximum of 65 mm (four-men bob) from the bottom surface of the runner.

14.2.7.5 Connection between Runners and Runner Carriers

- 1) The runners must be attached to the runner carriers using minimally 14 mm thread (two-men bob) and minimally 16 mm thread (four-men bob) bolts with hexagonal nuts.
- 2) No portion of the bolt may be smaller in diameter than 12.5 mm. (two-men) and 14.5 mm. (four-men)
- 3) The minimum height of the hexagonal nuts must be 11 mm (two-men bob) and 13 mm (four-men bob).
- 4) The nuts must not be welded to the holding brackets of the runner carriers and they must not be cased, clad or streamlined.

14.2.7.6 Runners Miscellaneous

- 1) The runner is shown in Figure 21.
- 2) Any aerodynamic covering of the runners is prohibited.

14.2.8 Detachable, moveable and/or adjustable parts

14.2.8.1 Purpose of 14.2.8

The purpose of 14.2.8 is to promote that the detachable, movable and/or adjustable parts of a bobsleigh are suitable for their intended purpose and do not pose a risk for bystanders and/or those participating in IBSF events. Also, the purpose of art. 14.2.8. is to promote a fair competition.

14.2.8.2 Brakes

- 1) Only harrow type brakes are allowed.
- 2) The brake cut-out must be open. A rubber membrane around the brake handles may be used.
- 3) No attempt may be made to reduce the area of the cut-out with any material.
- 4) The brake is actuated with two separately activated handles. In a four-men bob, the handles must be located either side of the brakeman.
- 5) The geometry of the brake must be designed in such a way that when applied by a single handle, with a full team complement, none of the brake components are permanently deformed (Figure 20).
- 6) The length of the handle, measured from the centre of the pivot, must be minimum 220 mm (two-men bob) or 350 mm (four-men bob).
- 7) The length of the braking arm measured from the centre of the pivot to the top of the harrow must be minimum 150 mm (two- and four-men bobs).
- 8) The height of the harrow must be minimum 35 mm (two- and four-men bobs).
- 9) The height of the teeth of the harrow must be minimum 20 mm (two- and four-men bobs).
- 10) There will be a minimum of 5 teeth over a total minimum length of 230 mm (two-men bob) and a minimum of 6 teeth over a total minimum length of 280 mm (four-men bob).
- 11) The teeth must be able to reach and cut the ice for a minimum of 50 mm below the runner standing surface.
- 12) Rubber or rubber-like material may be used in the retraction mechanism of the brakes

14.2.8.3 Push bars

- 1) Both the driver's side push bar and the side push bars must be retractable.
- 2) The height of the side push bar for the second or third team member (four-men bob) must be the same in the extended and retracted positions.
- 3) When retracted, the side push bars must be essentially flush with the surface of the cowling.
- 4) The brakeman's handles must be immovable.
- 5) The brakeman's push handles (two- and four-men bobs) as well as the side push bars (four-men bob) must have a minimum height of 670 mm and a maximum height of 870 mm, measured from the standing surface of the runner carriers.
- 6) The total width of the side push bars (four-men bob) for the second and third members must not exceed 750 mm.
- 7) When the four-men bob side push bars have a vertical rotating axis, the push bar stanchion must be at least two-thirds the width of the push bar, for at least two-thirds of the push bar length with a maximum gap of 3 mm.
- 8) The front of the push bar stanchion tapers down to the cowling at a point not more than 450 mm ahead of the axis of the push bar (Figure 7).
- 9) For the purpose of retracting the push bar(s), rubber or rubber-like materials may be used.

14.2.8.4 Foot Rests and Hand Holds

Athletes must have means to hold on to the sled in case of a crash. Any sled must therefore have a sufficient number of handholds.

14.2.8.5 Steering ropes and Steering handles

Steering ropes that connect the steering handles to the steering mechanism must be of sufficient strength to withstand the forces encountered in practice and competition. Steering handles must be constructed in such a way that they will withstand the stresses encountered during practice and competition. Steering handles may be kept in place by the use of rubber or rubber-like material.

14.2.8.6 Carrying Bars

Bobsleighs may be fitted with carrying bars in the front bumper to facilitate transportation. In that case, carrying bars must be fitted in such a way that they remain retracted from start to finish and that under no circumstances they become detached during a heat. Rubber or rubber-like material may be used to keep the carrying bars in place.

14.2.8.7 Padding materials

Padding on the inside of the bobsleigh, used to protect athletes from injuries and that is in accordance with the rules of 14.2.3 and 14.2.4 may contain rubber or rubber-like material.

14.3 Miscellaneous

14.3.1 Purpose of 14.3

14.3.2 Principles and Properties

14.3.2.1 Applicability

14.3.2.2 Tolerances and Limits

14.3.2.2.1 Use of measuring equipment

- 1) Equipment used to establish whether bobsleigh equipment complies with the Rules must be used in a professional manner and according to the manufacturer's instructions.
- 2) The systematic and non-systematic errors of the testing equipment used for testing bobsleigh materials must be known to the materials inspectors.
- 3) Systematic and non-systematic errors of the measuring equipment used must be considered when testing bobsleigh materials. Tolerances of testing equipment should be discounted to the advantage of the teams or athletes.
- 4) In case of in situ-testing measurements indicating a violation of the rules that could result in disqualification, the measuring process must be repeated under controlled conditions

14.3.2.2.2 Quality of testing equipment

- 1) The testing equipment used for testing bobsleigh materials should be fit for that purpose.
- 2) All measuring instruments used in bobsleigh testing must be fitted with a label indicating the measuring tolerance
- 3) Passameters with equivalent tolerances may be used
- 4) Radiuses and convexity must be tested by using IBSF patterns.
- 5) (Surface) Harness must be measured by using calibrated measuring equipment
- 6) The composition of bobsleigh materials must be established by using calibrated measuring equipment.
- 7) Calibration of testing equipment must be performed on a regular basis and according to manufacturer's recommendations. In case of calipers, micrometers and Passameters, calibration standards must be available during testing.
- 8) Equipment used to perform in-situ measurements must be calibrated for that purpose.

14.3.3 List of Drawings and Figures

- 1) Figure 1 is a side view and
- 2) Figure 2 is a top view of a bob resting on a horizontal surface.
- 3) Figures 3 A, B, C and D define the planes with which the 'concave shape' rules will be controlled.
- 4) Figure 4 clarifies the flange required at the front of the pilot's cut-out.
- 5) Figure 5 shows the controlled dimensions of the front bumper cross-section.
- 6) Figure 6 defines the shape of the front and rear bumpers from a top view and at the point of contact to the wall.
- 7) Figure 7 clarifies dimensions and tolerances of the side push bar stanchion.
- 8) Figures 8 and 9 depict the essential constructive elements top view and (partly sectional) side view, respectively, with dimensions corresponding to a two-men bob.

- 9)
- 10) Figure 10 is a (partly sectional) front view of the frame and front axle region of a two-men bob.
- 11) Figure 11 depicts the top and side views of the runner carriers of a two-men bob.
- 12) Figure 12 depicts the front view and bottom view of the front axle of a two-men bob.
- 13) Figure 13 depicts the rear axle of a two-men bob.
- 14) Figures 14 and 15 depict the essential constructive elements top view and (partly sectional) side view, respectively, with dimensions corresponding to a four-men bob.
- 15)
- 16) Figure 16 is a (partly sectional) front view of the frame and front axle region of a four-men bob.
- 17) Figure 17 depicts the top and side views of the runner carriers of a four-men bob.
- 18) Figure 18 depicts the front and bottom view of the front axle of a four-men bob.
- 19) Figure 19 depicts the rear axle of a four-men bob.
- 20) Figure 20 depicts the construction of the brake (two and four-men bob).
- 21) Figure 21 shows the essential dimensions of the runners (two and four-men bob).
- 22) Figure 23 depicts the connection between the cowling and the frame, the position relative to the division line of the forward travel stops limiting the movement of the cowling relative to the frame and the position relative to the rear axle of the rear travel stops limiting the movement of the cowling relative to the frame.

15. DRAWINGS

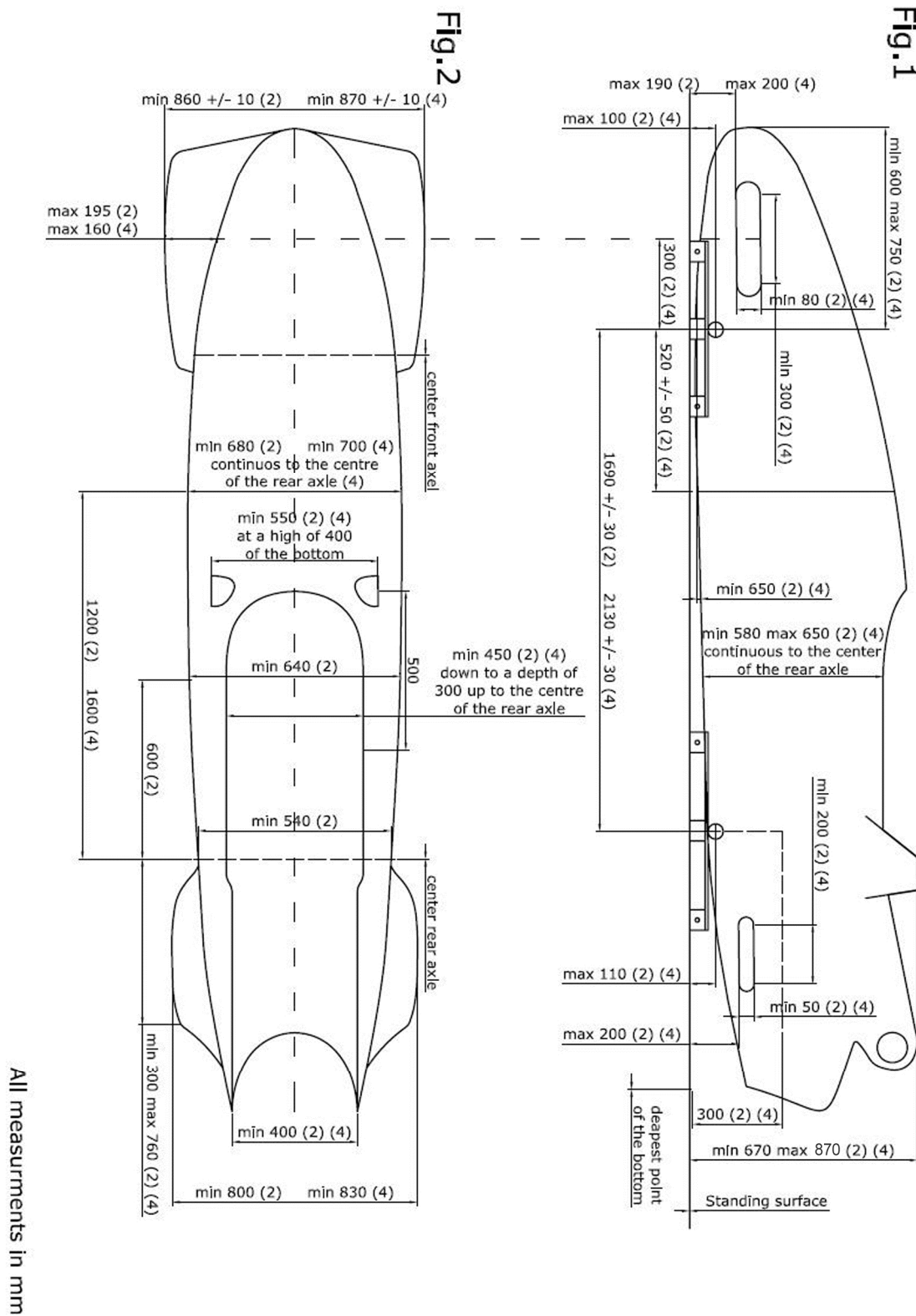
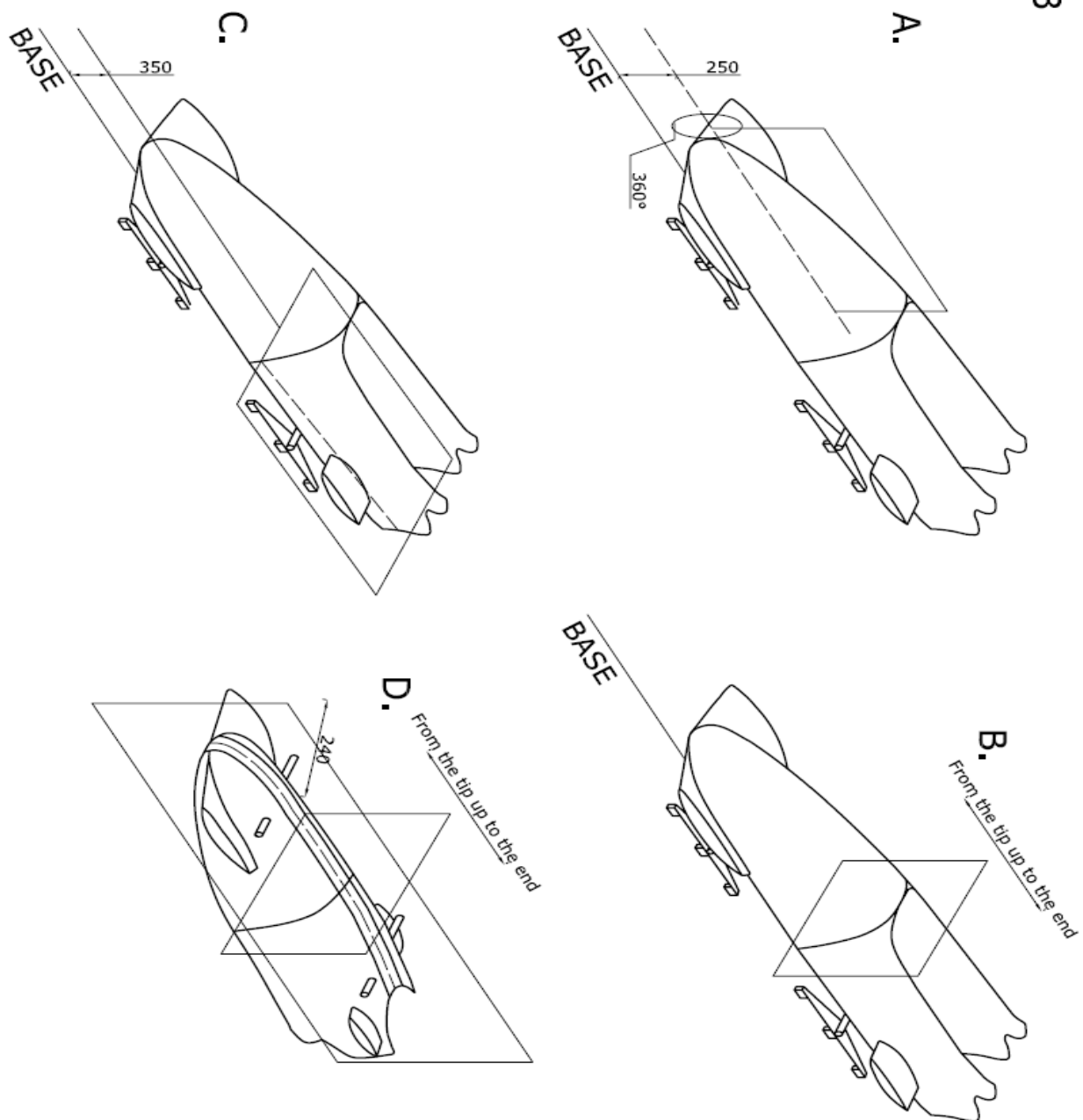

Fig.3



All measurements in mm

Fig.4

View A of Fig. 1 and 2

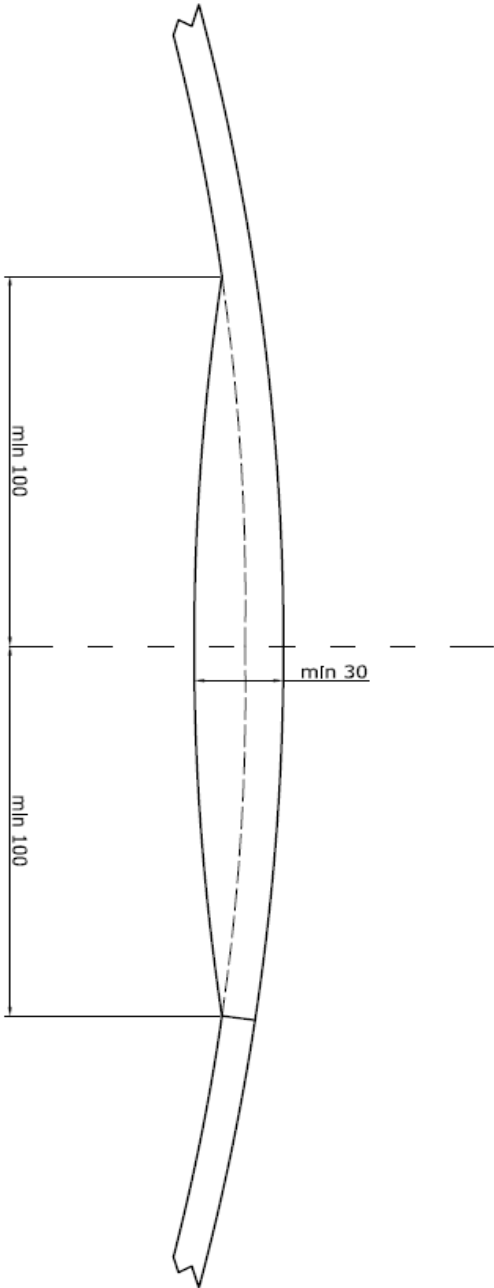

All measurements in mm

Fig.5

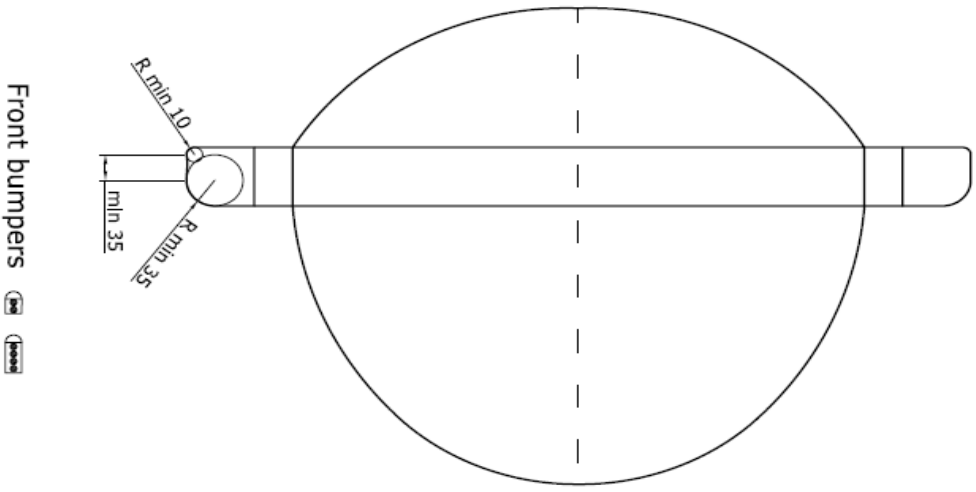

Front bumpers

Fig.6

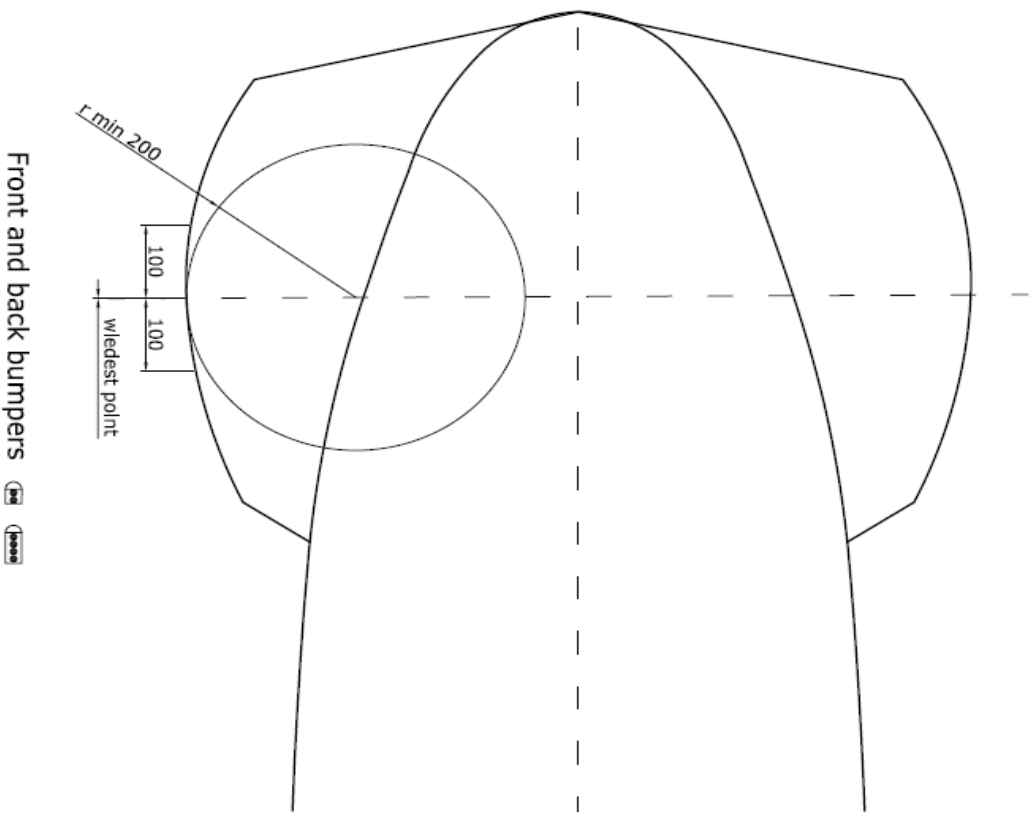

Front and back bumpers

All measurements in mm

Fig. 7 : Side pushbar dimensions and maximum stanchion dimensions (allowed areas of concavity)

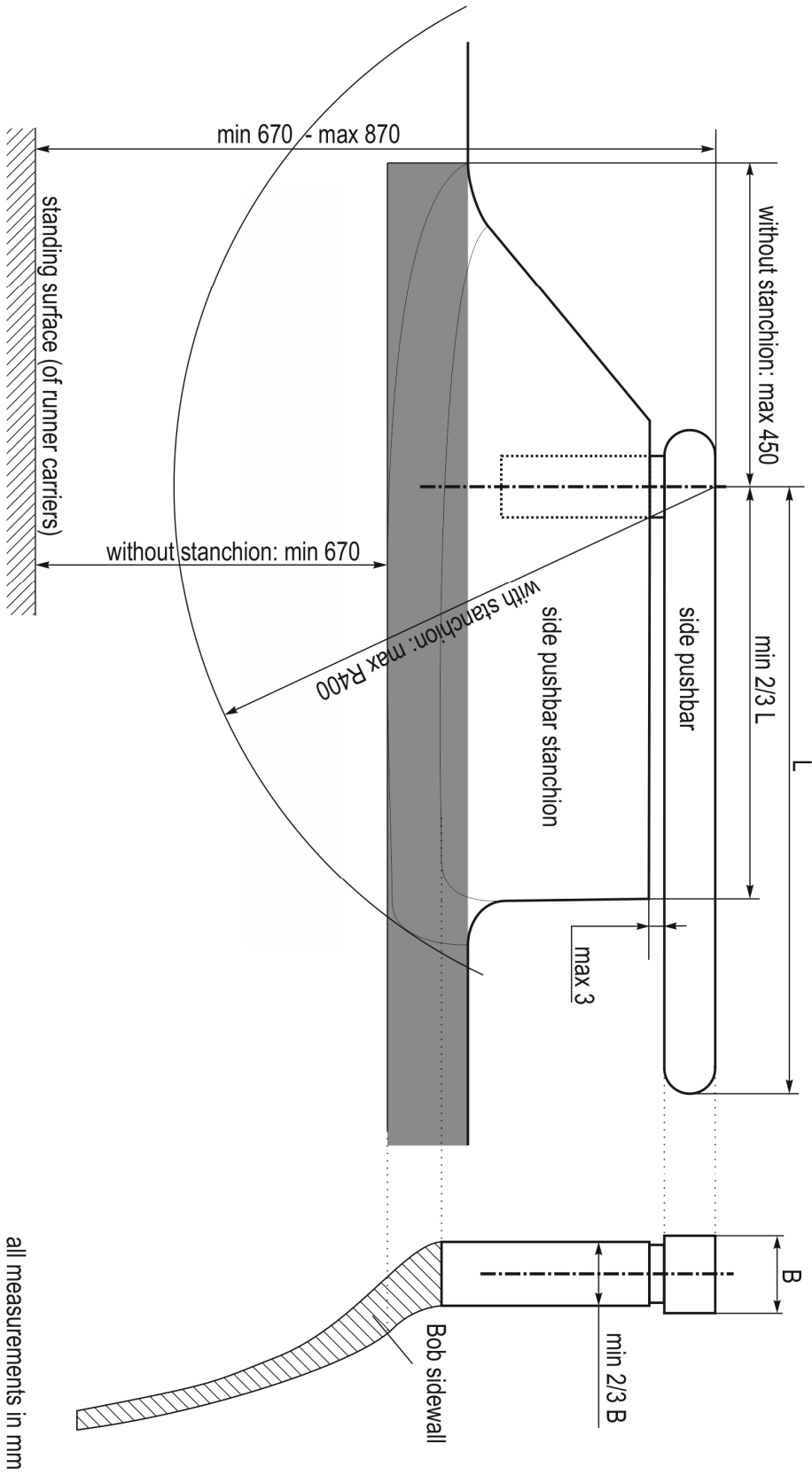
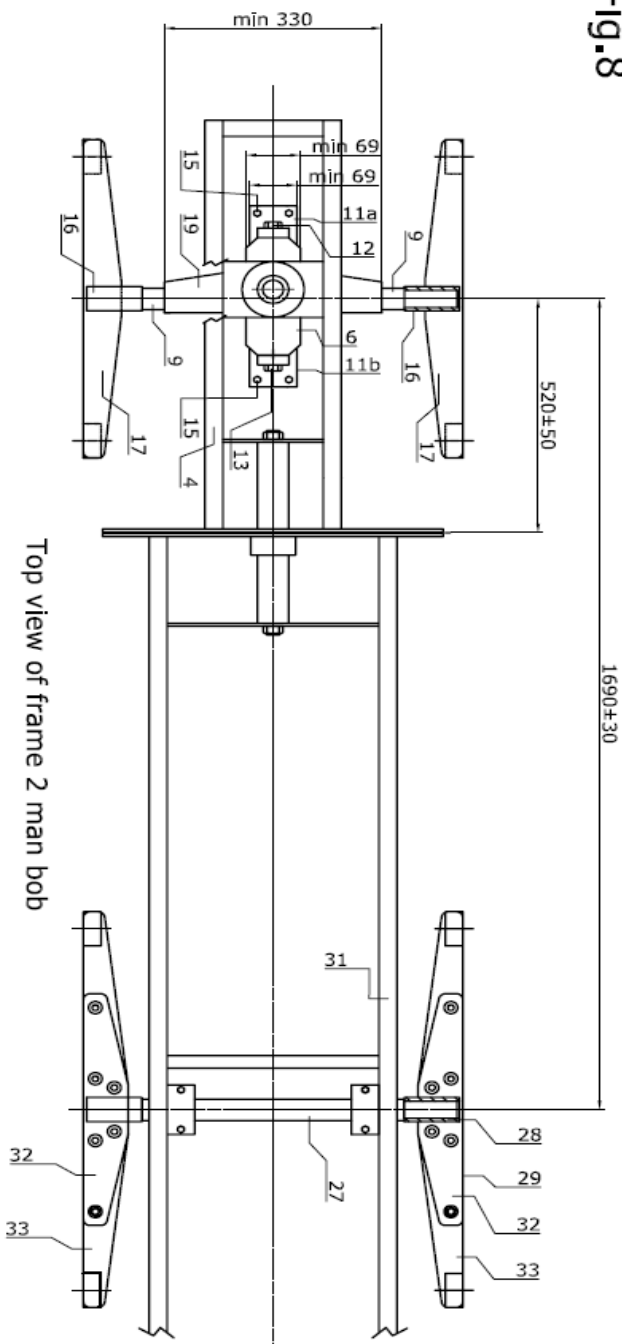
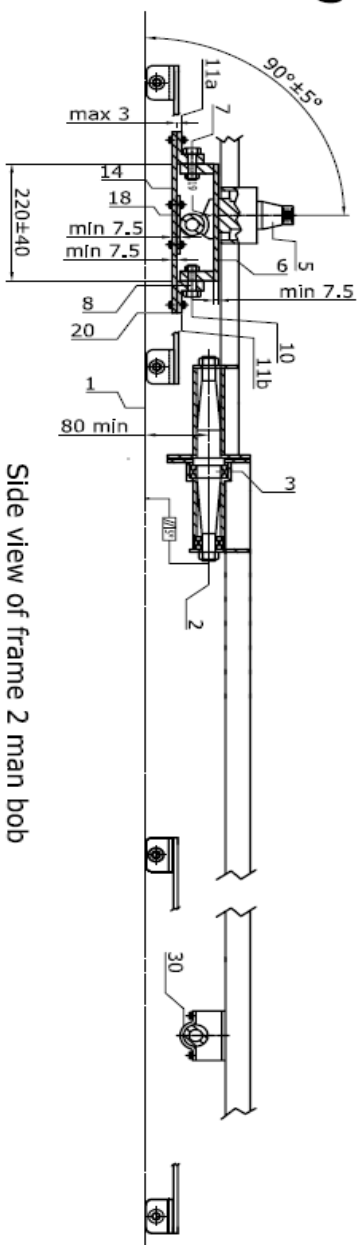

Fig.8



Top view of frame 2 man bob

Fig.9



Side view of frame 2 man bob

All measurements in mm

Fig.11

Runner carriers 2 man bob

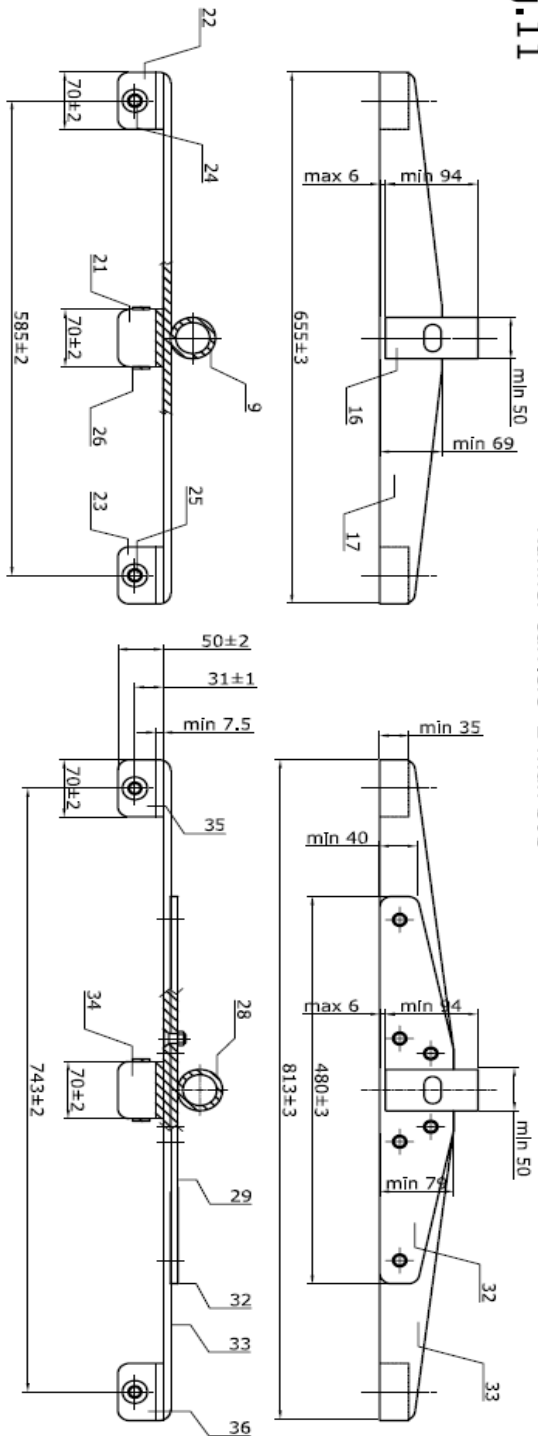
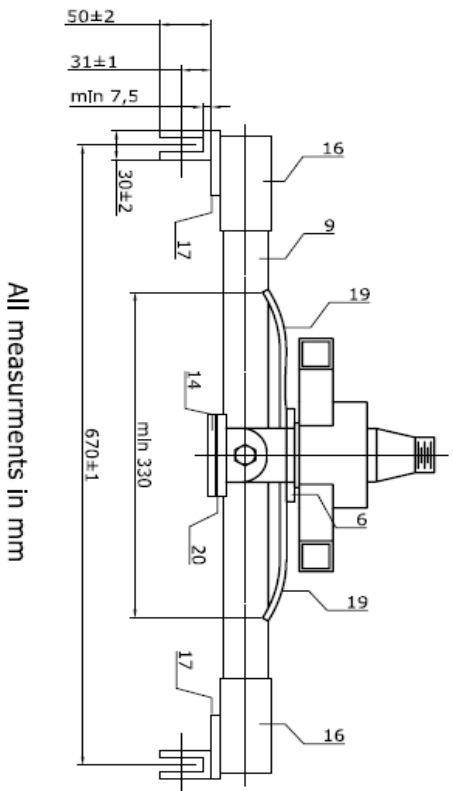

Fig.10

Front view of frame 2 man bob



All measurements in mm

Fig.12

Front axel 2 man bob

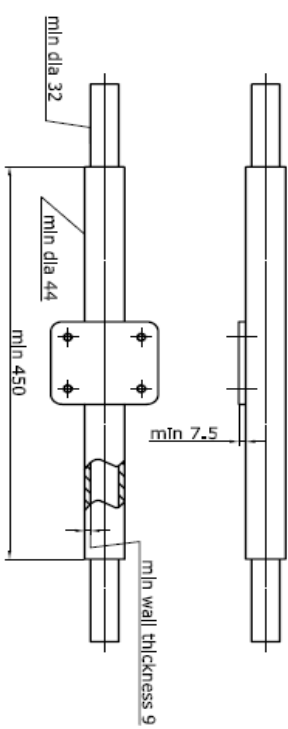
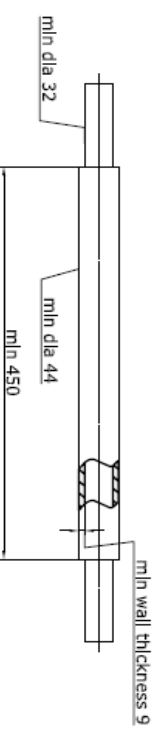
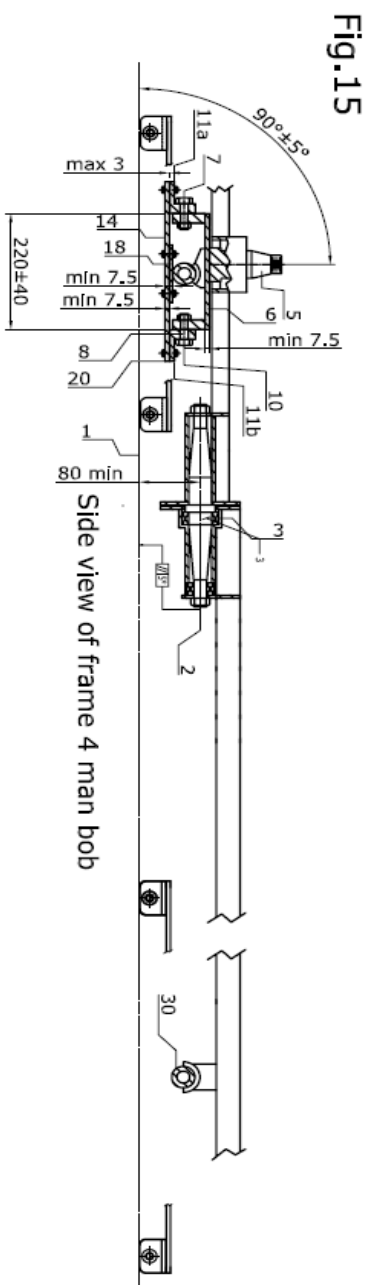
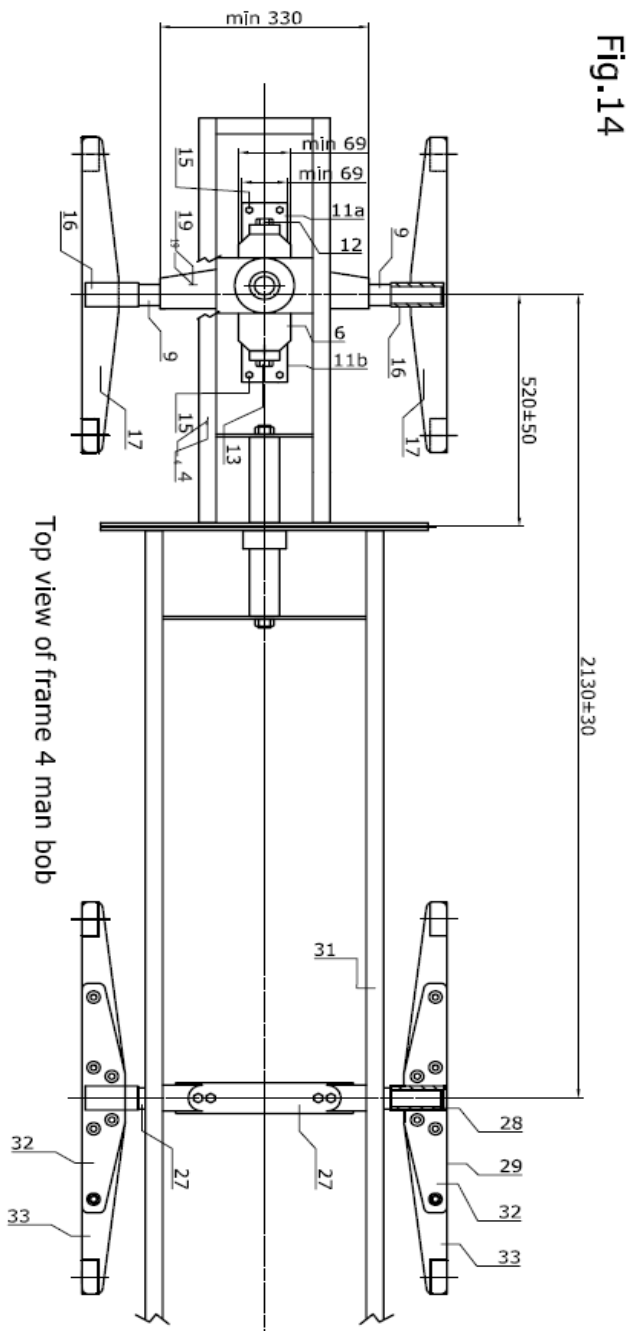

Fig.13

Rear axel 2 man bob





All measurements in mm

Fig.17

Runner carriers 4 man bob

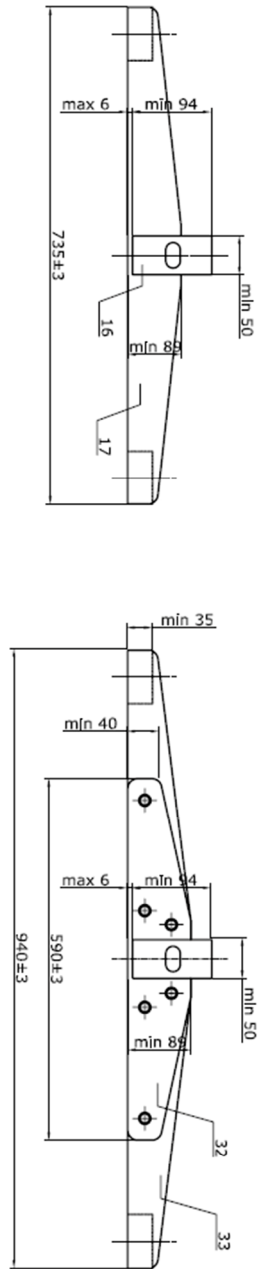

Fig.16

Front view of frame 4 man bob

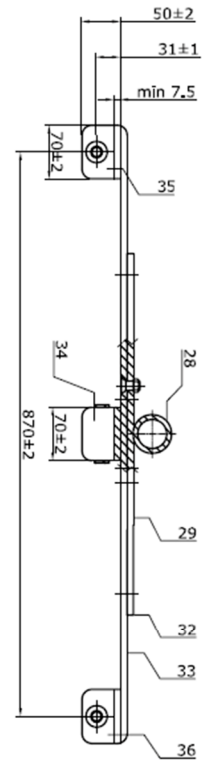
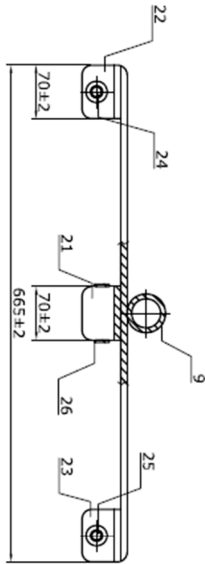

Fig.18

Front axel 4 man bob

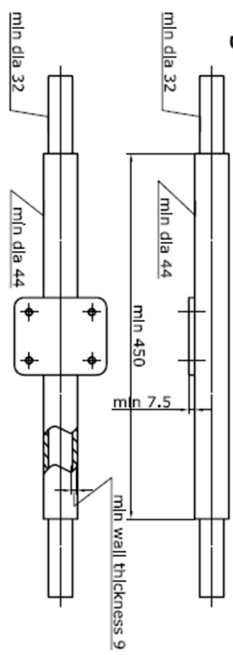
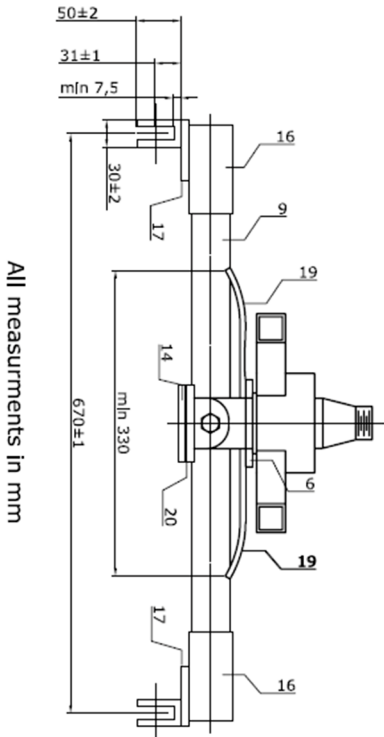
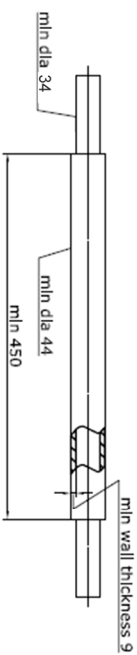

Fig.19

Rear axel 4 man bob



All measurements in mm

Fig.20

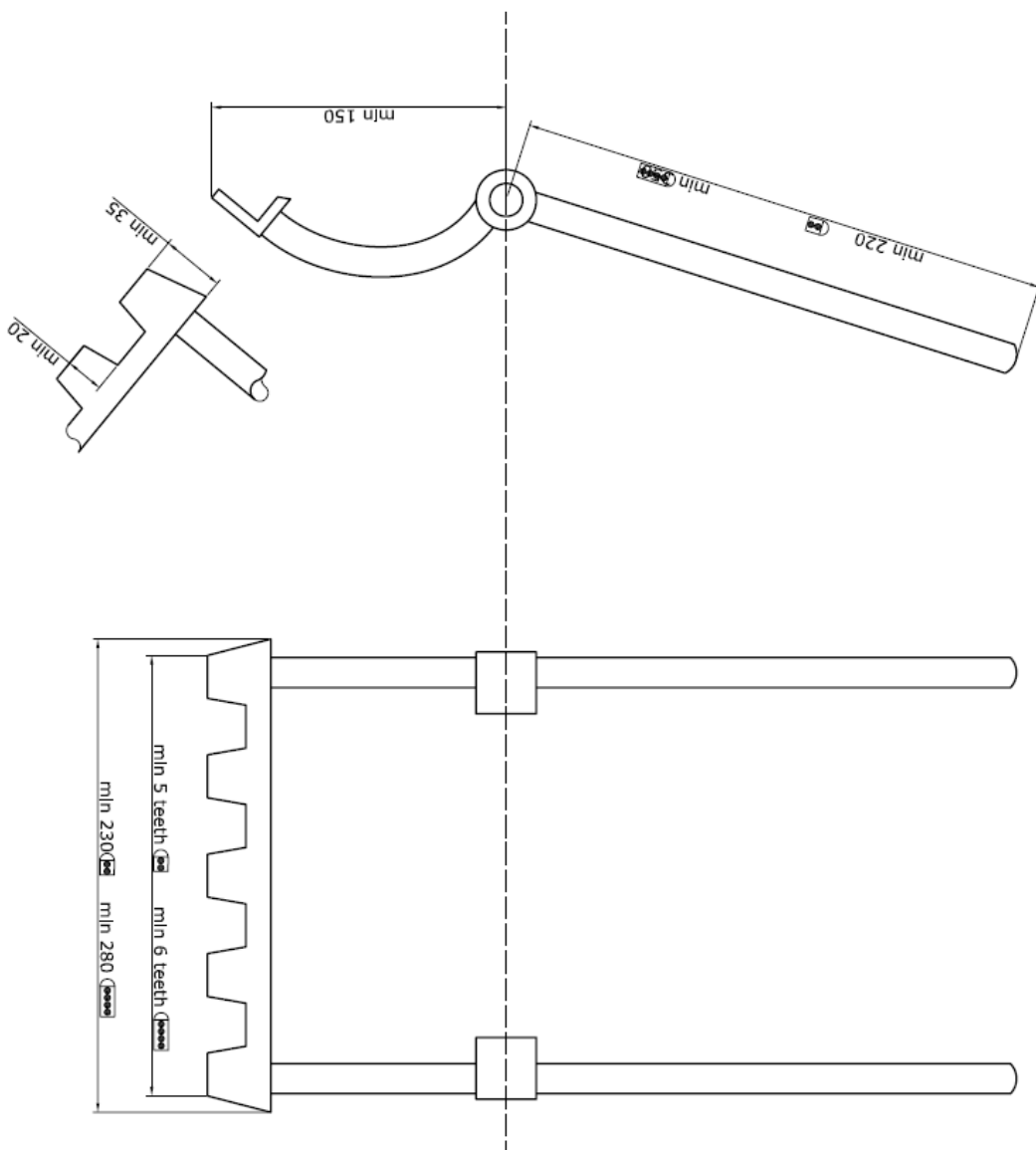

All measurements in mm

Fig.21

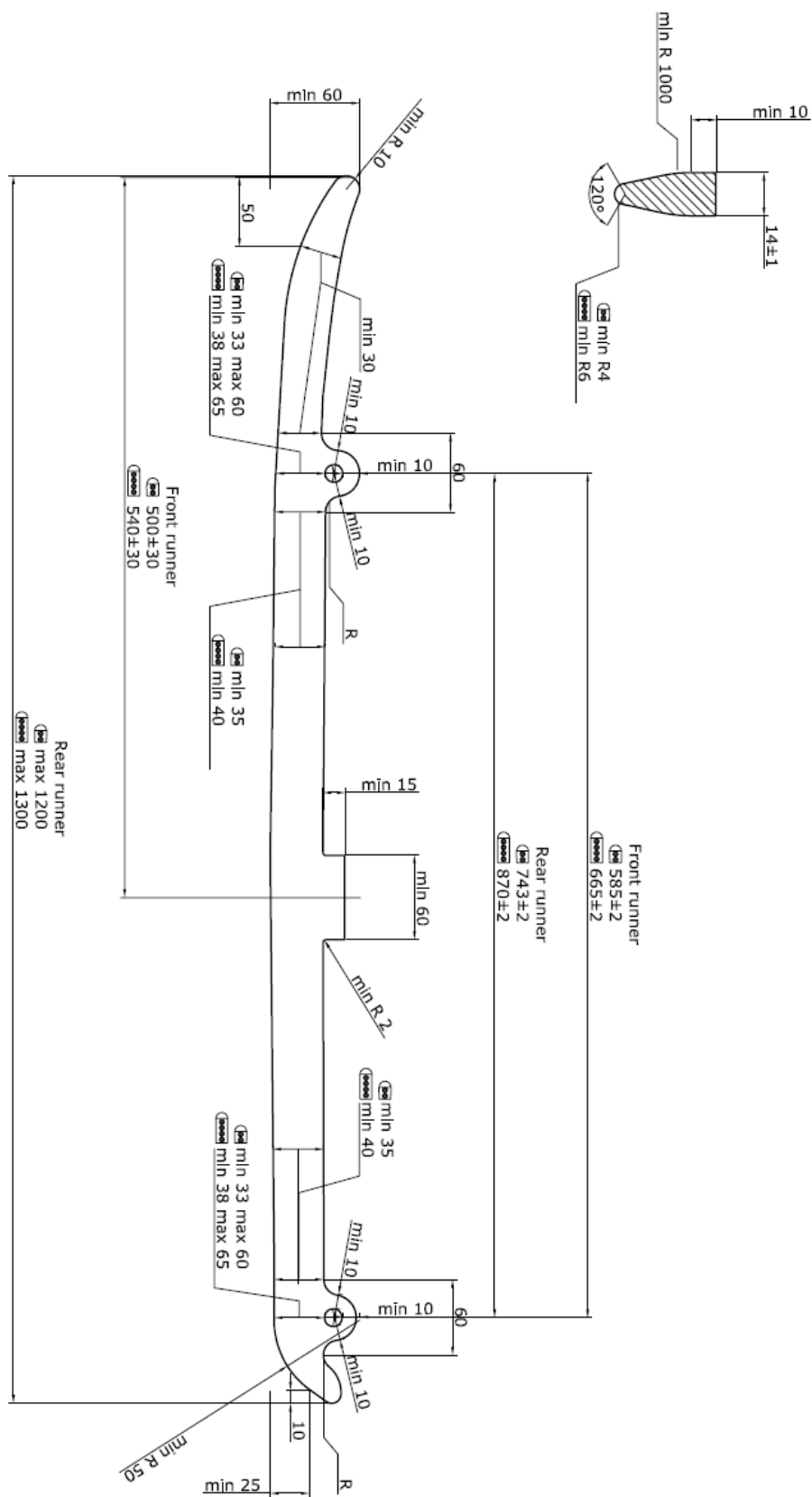

All measurements in mm

Fig. 23: Rear frame: required mounting points of cowling-to-frame-brackets and travel stops

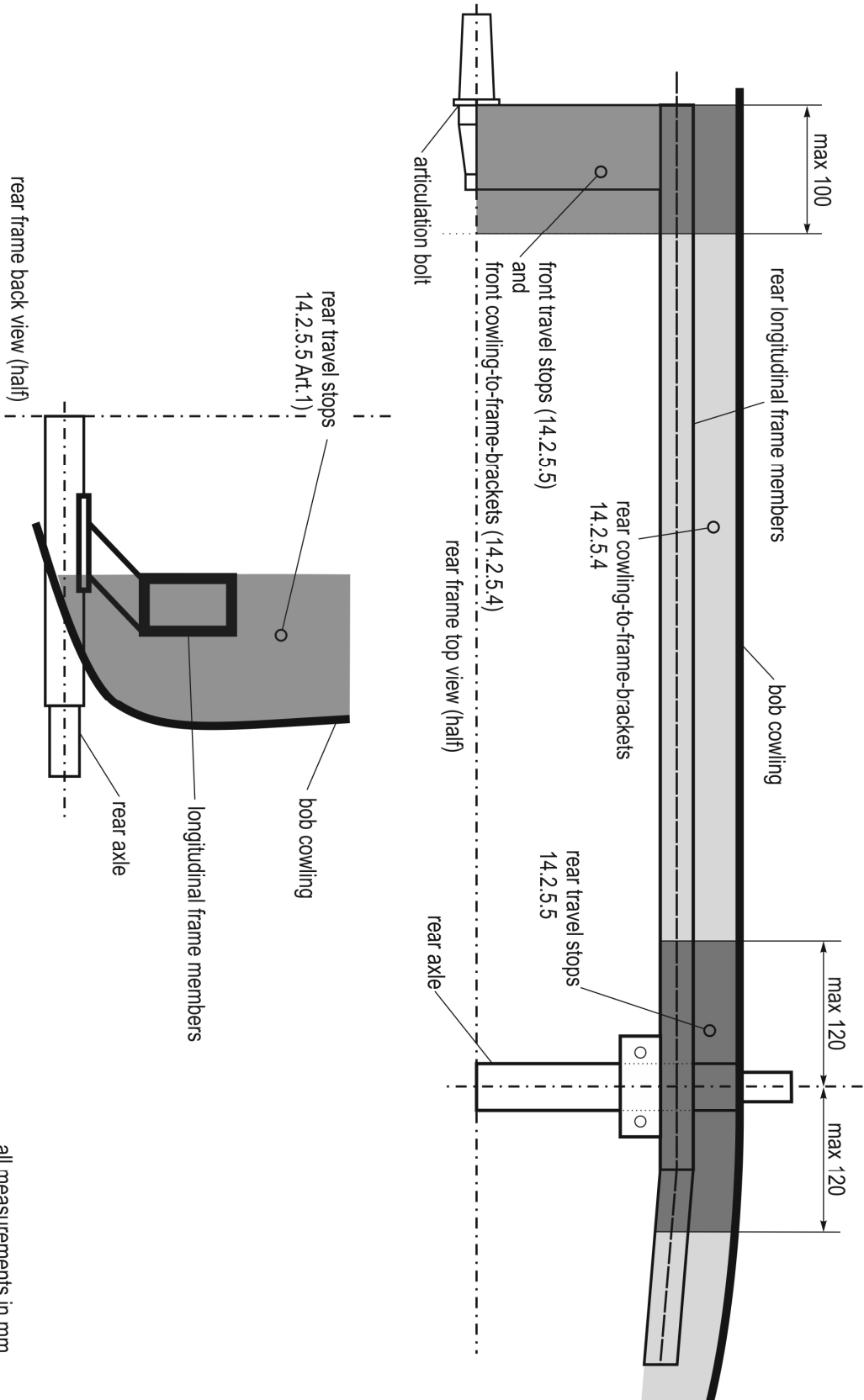

15.1 APPENDIX 3: MATERIAL SEIZURE

Procedure for the seizure of sled components for conformity tests.

Empowered by the Jury and in the presence of at least one of its members, the IBSF Materials Committee responsible directs the official representative of the Federation to which the sled belongs to remove or disassemble the component(s) to be tested.

15.2 The Form

Upon collecting the component(s), the IBSF Materials Committee will fill in a form drawn up in six copies, stating:

- General data of the team / athlete whose sled is being tested
- The name of the competition and the venue
- The date and time
- A description of the component(s) taken
- The type of test(s) the laboratory is required to perform
- A blank space for entering the laboratory analysis results

The following people will sign the form:

- The Jury President
- The representative of the IBSF Materials Committee
- The team captain or official representative of the Federation to whom the sled belongs

The six copies of the form will be sent to the following:

- One copy to the Jury President
- One copy to the IBSF President (via the Secretary General)
- One copy to the Chairman of the IBSF Materials Committee
- One copy to the team captain or official representative of the Federation to whom the sled belongs
- Two copies to the laboratory, together with the container holding the component(s) to be tested

By returning one of the two copies of the form to the IBSF Secretary General, the laboratory confirms that it has received the container undamaged.

15.3 The Container

The seized components will be sealed in a container.

15.4 Remarks

The IBSF bears the costs of the laboratory analysis. In case of positive analysis results, the IBSF can order the costs to be reimbursed by the Federation to whom the sled belongs.

PROTOCOL FOR SEIZURE OF SLED COMPONENTS FOR CONFORMITY TESTS

Place:	Date:	Time:	Competition:
--------	-------	-------	--------------

Event:	Nation:
--------	---------

Description of component/s taken:	
-----------------------------------	--

Test/s required:	
------------------	--

Name of Laboratory:	
---------------------	--

Laboratory result:	
--------------------	--

President of Jury	Materials Commission	National Federation
Name:	Name:	Name:
Signature:	Signature:	Signature:

The Laboratory Acknowledges receipt of the official container bearing unbroken seals, from. On (date)	In the person of: At (time)
Stamp:	
Signature	

16. APPENDIX 4: THE TRACK

Combined Bobsleigh, Skeleton and Luge Tracks

16.1 Scope

New combined bob, skeleton and luge tracks shall be constructed in such a way that they are suitable for the practice of bob, luge and skeleton racing with no limitations.

For the purpose of designing, constructing and using the tracks, the greatest attention shall be paid to the environment and its protection.

The directives, which track constructors must observe, shall be designed in such a way as to keep the costs of the tracks as low as possible and to guarantee satisfactory use of the installations after the Olympic Winter Games.

16.2 Environmental Protection

The environmental manual, 'IBSF and the Environment' is an integral part of these rules. It must be considered in the preparatory phase, in the design, and during operation of the track. [See Section 18 Appendix 6]

16.3 Technical Commission

The IBSF and the FIL each constitute a commission that will supervise jointly the preparatory phase of the design, the design itself, the construction and the commissioning of each track.

The IBSF and FIL Technical Commissions are at the disposal of bob, skeleton and luge track constructors and managers to provide consultancy free of charge.

16.4 Preparatory Phase of Design

The IBSF and FIL Technical Commissions shall be called upon to effect an inspection and to provide consultancy before a decision is made regarding the terrain on which the track will be constructed.

The Commissions shall present a written report on the terrains, specifying the documents to be submitted to them for further consideration.

16.5 Design in General

The IBSF and FIL Technical Commissions shall be periodically called upon during the track design phase.

The Commissions shall approve the chosen terrain and the basic project.

The same rule applies in case of changes regarding the choice of the terrain and the basic project.

16.6 Location of the Track

If possible, the track shall be located on the north side of the slope and be easily accessible via normal channels of communication. Its trajectory shall - as far as possible - follow the natural development of the terrain.

In order to guarantee optimal use of the track (after the Olympic Winter Games), it is of the utmost importance that the track be located close to a city or to a densely populated area.

16.7 Length of the Track

New Artificial combined bob, luge and skeleton tracks shall be 1200 - 1650 meters long, 1200 meters of which shall be sloping downhill. The last approx. 100 – 150 meters may consist, depending on speed, of an uphill stretch that shall have bends.

The maximum gradient of this stretch must not exceed 12%.

Speed at the finish shall be higher than 80 Km/hr.

After time keeping at the finish, the stopping stretch shall be straight and not have any further bends.

16.8 Track Characteristics

The track shall include elements of varying technical difficulty.

Particularly demanding elements in terms of driving technique shall be located in the first stretch, which accounts for two thirds of the track.

At design level, it is to be foreseen to be able to reach a speed of between 80 and 100 Km/hr after the first 250 meters.

Bends, combinations of bends and straight stretches of a suitable length shall be inserted into the track.

16.9 Starting Area: Bobsleigh and Skeleton

16.9.1 Push-Off Stretch

The push-off stretch means the part of the track between the start block (wooden board) and the first photoelectric cell.

This stretch shall be 15 meters long and have a gradient of 2%.

The rearmost part of this stretch must consist of a block (wooden board) fixed to the ground, which must not be removed, nor passed.

16.9.2 Start Block (Wooden Board)

The start block must be at least 150 cm long, 20 cm wide and 5 cm high from the surface of the ice.

16.9.3 Starting Area

After the first photoelectric cell (start- line), the track must follow a straight path so that bobsleds starting off may reach a speed of 35 Km/hr. The track must be sufficiently wide in order not to obstruct teams.

The gradient of a 60 m stretch must be equal to 12%.

The stretch between the first photoelectric station must be 50 m long (starting time).

16.9.4 Preparation

Behind the start block (wooden board), there must be a preparation area with a frozen base, of such a size that it can accommodate two bobsleds on the ice without obstructing the team about to start off.

16.9.5 Start Procedure Time Limit

If the start does not take place within 60 seconds (bobsleigh) or 30 seconds (skeleton), the light must be switched to red. When the light is switched to red, an acoustic signal must be sounded.

16.10 Luge Start

16.10.1 General Aspects

For descents in men's, women's, junior and double luge events, the track must be equipped with all the necessary starting structures for guaranteeing the normal execution of trials in all specialties.

During competitions it must be possible to delimit the starting zone.

16.10.2 Starting Zone

The following structures are part of the starting zone:

- A horizontally frozen surface which enables the athlete to assume a sitting position on the luge.
- The length of this horizontally frozen surface measured in the direction of push-off grips must be at least 2000 mm.
- The length of the horizontally frozen surface between push-off grips and the beginning of the sloping stretch is 500 mm.

16.10.3 Push-Off Grips

Two 'push-off' grips are fixed to the side of the track and they are adjustable vertically and horizontally, and can be used by the athlete to increase the initial speed.

Distance between the surface of the ice and the upper edge of the 'grips' at the same height: 230-250 mm.

Space between the two 'grips': 700 mm.

Width of 'grips' for hands: each grip at least 150 mm wide, 27 mm in diameter. Surface of the grip must be knurled in its whole width.

The 'grips' must be constructed in such a way that they cannot be distorted when subjected to traction by the athlete.

The 'grips' must be adjustable both horizontally and vertically, to ensure compliance with the above-mentioned measurements.

16.10.4 Starting Stretch

The starting zone must be sufficiently curved in both its upper and lower parts (radius of the upper part at least 2 m, radius of the lower part at least 10 m), to allow the luge to enter the track without changing its trajectory.

The distance between the start grip and the first photoelectric cell must be approx. 7 m. The distance between the first photoelectric cell and the first intermediate time-keeping station must be approx. 3 - 6 seconds (start time).

The starting ramp and the track itself must meet at an angle of no more than 8°.

16.11 Bends

The bends must be constructed in such a way as to allow sleds to move not only along a single trajectory, but to provide a band of possible trajectories from which to choose.

In the central part of the bend, the trajectory should extend along the upper half of the bend.

Entries and exits from bends must be rounded so that the sleds can take them smoothly with no risk of capsizing, if no mistake is made in driving.

16.12 Guardrails in Bends

Guardrails in bends (bumpers) must be constructed in such a way that they return the sleds on to the track.

They must be sufficiently long and wide.

16.13 Centrifugal Force

The maximum time for which centrifugal force of '4G' may occur is 3 seconds.

The maximum centrifugal force allowed is '5G'; this centrifugal force must not last for more than 2 seconds.

16.14 Straights

In the iced construction, maximum width is 140 cm. The external part of the sidewalls of the straight stretches should not be higher than 80 - 100 cm, including any raised section.

In the iced state, the inside part of the sidewalls must be at least 50 cm high.

The sidewall of straight stretches must be at a right angle to the track base.

The transition between the sidewall and the base of the track must be provided with a channel. In the iced state its radius must be 10 cm.

In transitions linking a bend to a straight, the raised part of the bend must run into the sidewall of the straight gradually in a sufficiently long section.

16.15 Deceleration Stretch

The deceleration stretch must be constructed in such a way that the bobsled, the skeleton and the luge can stop even without applying the brakes. The gradient of the deceleration stretch must not be in excess of 20%.

At the end of the iced stretch, sleds must be able to continue without any obstacle. If considered necessary, at speeds less than 30 Km/hr, special cushioning devices may be installed, in order to avoid any injury to people and to restrict damage to sleds to a minimum.

For skeleton, sufficient foam rubber mats have to be made available. If possible water-repellent (approx. 100 x 150 cm, maximal thickness 6 cm.).

16.16 Lighting

In the event lighting should be required for training and competitions, the following conditions must be complied with:

- a) Uniform lighting intensity, without shadows and reflection.
- b) The lighting system must be powered by two independent systems, one of which must also be independent of the mains power supply.
- c) If one of the two circuits breaks down, 50% of the planned lighting capacity must be nevertheless guaranteed.

16.17 Solar and Weather Protection Devices

The stretches of the track exposed to the sun and/or to adverse weather conditions must be protected by means of proper devices.

On bends, protection may be provided by fixed roofs combined with the coverings of the bends.

On straight stretches, a removable type of covering, open on one side of the track, must be adopted. It is forbidden to install roofs with fixed coverings on straight stretches. Any pillars and fixture systems shall be at a distance of 50 cm from the inside of the track wall.

Coverings shall not interfere significantly with television filming or the view of spectators. They should possibly be of the removable type.

Local climate conditions must be duly considered.

16.18 Water Supply

A plumbing system must be installed along the track, protected from freezing and provided with a sufficient number of properly protected hydrants.

Access to the hydrants from the track must be guaranteed.

16.19 Catwalks

Catwalks must be installed along the track, along which members of the Jury, the Technical Delegate and trainers may stand. Access by spectators to these catwalks must be prevented.

The position of these catwalks is established by the Technical Commissions on approval of the project.

16.20 Infrastructures - Ancillary Facilities

The spaces for the warming up section, shelters to store bobsleds, the building at the starting zone and for weighing, must be sufficiently large.

In particular sufficiently large areas for warming up of athletes shall be foreseen in the open air.

A medical first-aid room, an anti-doping room, a room for controlling material and a press centre shall be foreseen.

Ancillary facilities may also be of a temporary type.

Their construction is established jointly by the author of the project and the Technical Commissions.

16.21 Buildings at the Start and Finish

Two buildings must be constructed at the Start, one of which must be situated near the upper starting zone, namely for bobsleigh, skeleton and single luge (men). The other shall be located near the lower starting zone for the single luge (women), double luge (men) and Juniors. There is only one building at the finish for all specialties.

16.22 Partitioning of Costs

The budget and the costs for building a combined bob and luge track are to be presented as follows:

- a) Costs of the track and infrastructures resulting from the compliance with these rules and with the directives of the IBSF and FIL
- b) Remaining costs, e.g. longer track, improved infrastructures, approach roads, developments, etc.

The exact partitioning is determined between the constructor and the Technical Commissions of the IBSF and the FIL.

16.23 Exceptions

Exceptions may be made in certain cases. The Vice Presidents of the FIL and the IBSF must authorize these exceptions in writing.

However, these decisions shall not affect safety, nor imply any significant reduction in sporting value and shall not interfere with television filming.

16.24 Homologation

Before IBSF competitions take place, recently the IBSF Technical Commission must homologate constructed or restructured bob, skeleton and luge tracks.

For this homologation, the IBSF assumes no responsibility for the accuracy of calculations or for the execution of works for constructing or restructuring the track. (This responsibility shall be assumed by the architect/engineer who designed the track and by the construction company).

17. **APPENDIX 5: ADVERTISING GUIDELINES AND DRAWINGS**

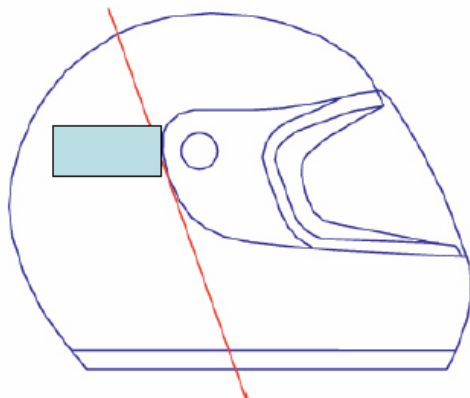

IBSF properties: helmet (bob & skeleton)
 Left and right side of the helmet, as close as possible to the visor
 Size: 50 cm²

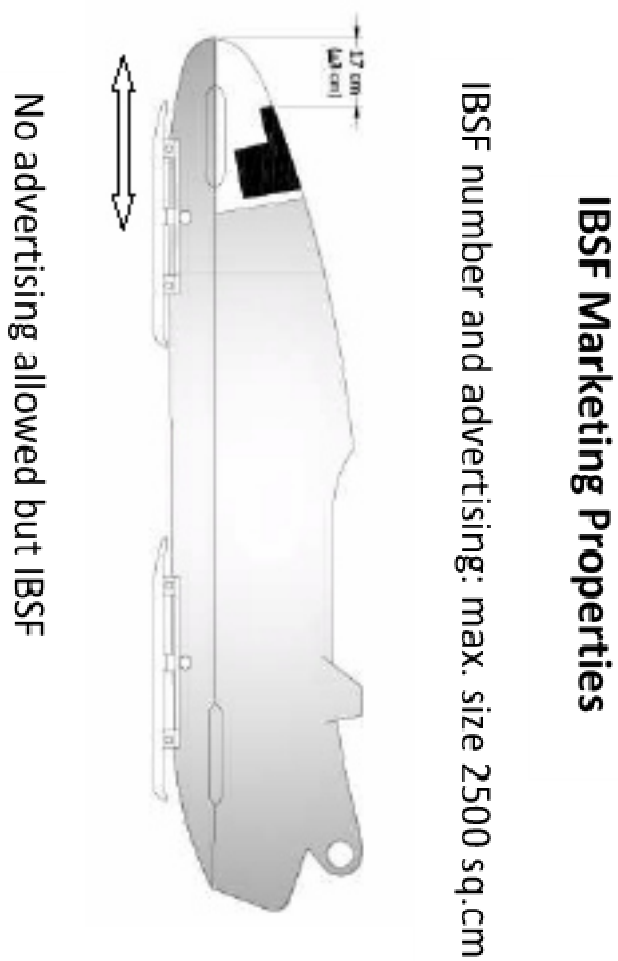

IBSF Marketing Properties

IBSF number and advertising: max. size 2500 sq.cm

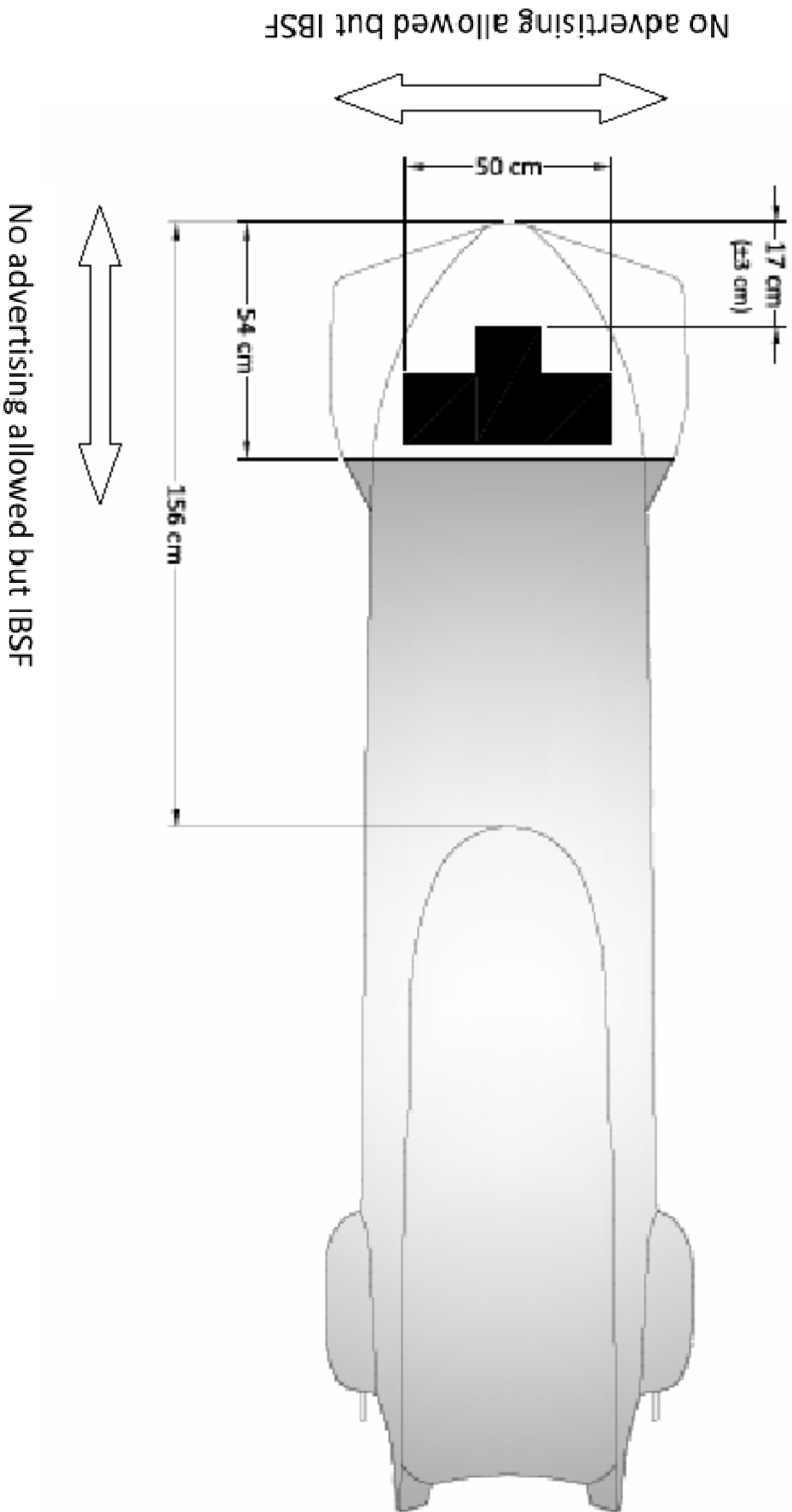

APPENDIX 6: THE IBSF and the ENVIRONMENT

17.1 Our Events

In recent years, event organisers have become more aware of the potential impact of major sporting events on the environment – in terms of pollution, ecosystems, and waste. As a result, environmental protection has become an increasingly important issue. “IBSF and the Environment” has been prepared for track managers and event organisers to host environmentally responsible sports events. Every sport and every occasion has its own characteristics and it would be impossible to cover all eventualities, but



whether the event is large or small, one-off or recurrent, it will have many basic attributes in common with others.

The IBSF through its membership of the Olympic Movement is a supporter of the IOC's Agenda 21 programme that sets out the principles and guidelines for Sport for sustainable development.

The facilities used in the exercise of our sporting disciplines can have a major impact on the environment, both the act of construction and subsequently in their operation over the lifetime of the facility. It is therefore important that all venue owners, managers and users accept that protection of the environment must remain an important element of our planning and event delivery.

17.2 Seven steps to greening your event

17.2.1 Adopt a green policy

The first step is to adopt an environmental policy, and determine what you want to achieve, set targets, and adopt measures to evaluate your success. Normally there will be at least two principal parties: the Race Organisers and the race venue. All main partners should approve the policy in order to establish a solid commitment to the programme.

17.2.2 Carry out an 'Environmental Scoping Review' of venues and operations

For each event, it is essential to establish base line information on current environmental performance, and to identify specific opportunities for 'greening' the event. Where venues are used repeatedly, the previous occasion will provide a benchmark for subsequent events.

17.2.3 Establish environmental teams

The role of the Event Director will be pivotal in implementing the environmental programme. He/she should assemble and coordinate a core team to carry this through – e.g. Site/Venue Manager, Head of Staff, Environmental Consultant and other technical specialists. Other experts or interest groups may

be included if appropriate, e.g. a representative from the local authority, or from relevant statutory agencies.

17.2.4 Define programmes and set appropriate targets

Targets need to be bold enough to be credible, but must also be attainable. It will be important to communicate the environmental policy and details of the programme to staff, suppliers, contractors, sponsors and officials, so that everyone can play their part.

17.2.5 Implement programmes

Venue-related measures will normally be in operation for as long as possible preceding the event. The event-related measures are likely to be temporary, covering the immediate build-up to, and duration of, the event.

17.2.6 Monitor implementation and adjust programme accordingly

The ability to measure and record basic environmental parameters is the first real test of performance and the effectiveness of the programme.

17.2.7 Evaluate and publicise results

The major gain from this process is raising awareness, both among the sports community and the general public. The green message can be emphasised during the lead-up, at the event itself, and as part of the post-event legacy. As far as possible it should be integrated within the normal event communications.

17.3 Action Plan

17.3.1 The impact of our sport

Climate change causes warmer winters and makes ice-making harder and more energy-intensive. From the moment an athlete begins to use equipment, apparel or facilities, there is an "ecological footprint" - an impact on the natural environment. On an even greater scale bobsleigh tracks will contribute to global and local environmental concerns. Building and managing a bobsleigh track and running an event can contribute to energy consumption, air pollution, greenhouse gas emissions and waste creation, as well as to ozone layer depletion, habitat and biodiversity loss, soil erosion and water pollution.

Bobsleigh and Skeleton tracks can affect the environment in the following ways

- Development of fragile or scarce land types [most tracks are located in vulnerable mountain areas]
- Pollution from liquid spills [refrigerant, fuels, cleaners, solvents]
- Noise and light pollution
- Consumption of non-renewable resources (fuel, metals)
- Consumption of natural resources (water, wood, paper)
- Creation of greenhouse gases by consuming electricity and fuel
- Ozone layer depletion (from refrigerants)
- Soil and water pollution from refrigerant use
- Soil erosion and compaction during construction and from spectators
- Paper consumption by media and officials

17.3.2 The Facility

Bobsled, Skeleton and Luge tracks are costly, single-purpose facilities that require considerable terrain and construction materials and which can use potentially harmful refrigerants. There are, however, ways to minimize their environmental impact.

- Design

Tracks should follow the existing terrain and be partially underground wherever possible for reasons of energy efficiency, aesthetics and reducing demand for building materials. Where feasible, the use of all-natural ice tracks should be considered.

- Coolants

Cooling systems must be carefully designed to prevent any possible leak into the atmosphere of either ammonia or synthetic coolants. Ammonia poses a health risk and synthetic coolants harm the ozone layer when leaked.

- Energy efficiency

Tracks should be kept cooled only when demand is sufficient. Screens shading the track from the sun should be used wherever a demonstrable energy savings will result.

- Impacts on the Environment

Tracks can require bulldozing of slopes and cutting of trees

Impacts of facility maintenance activities [noise, pollution, disruption of the natural environment]

Waste generated from signs, food services, banners, temporary booths, etc

17.4 Areas of action

Managing a Bobsleigh and Skeleton event involves a wide range of actions related to the concentration of infrastructures and people. Environmental measures can be included in several areas of action.

17.4.1 Location and landscaping

Location is the critical point of a facility or event. It determines not only its environmental impact but also its accessibility, proximity to users and visual impact. The choice of location can either reduce or intensify the negative influence of the facility or event. An environmentally sound site is usually financially sound as well.

The site selection occurs during the planning of new facilities or of national/international championships. Selection criteria have to be applied during the decision process.

The objectives are to:

- Minimize environmental impacts by choosing the most convenient site
- Conserve and protect special landscapes

17.4.2 Environmental elements to consider when choosing a location for sports venues are:

- Legal and physical boundaries, private holdings and public easements
- Buildings, bridges and other structures, including those of historical and archaeological significance
- Roads, paths and sidewalks
- Availability of public transport
- Electric lines, water, sewer and gas mains
- Solid waste: disposal sites, treatment plants, management and transportation
- Wastewaters: sewers, treatment plants
- Land use: residential, commercial, industrial and other applicable ordinances

17.4.3 Natural resources:

- Protected sites
- Forests
- Water resources
- Air quality

17.4.4 Natural elements:

- Climate conditions
- Local morphology

17.4.5 Perceptual elements:

- Landscapes
- Special elements
- Aesthetic values
- Cultural values

17.4.6 Detailed planning, once the site location has been selected:

- Plan the integration of the event or facility into the landscape
- Foresee protection measures
- Foresee restoration measures
- Foresee compensation measures

17.5 Sport facilities

Our tracks and associated facilities constitute the most visible part of our sports events or organisation. Their location, construction, materials and operation processes are potentially sources of high nuisance and damage. This may include land waste, landscape harm, high-energy consumption, pollution and waste of financial resources when such sports events or organisations are not adequately planned or seriously managed.

Our objectives are to:

- Avoid venues and locations with little or no post event usage
- Reduce location-related impacts (landscape, land use)
- Minimise energy consumption
- Reduce pollution

17.5.1 Planning phase

First of all, the advisability of the project has to be justified in order to avoid unnecessary and over-sized facilities.

When carrying out detailed planning, environmental criteria should be part of the decision-making process. During this phase, the project management team is responsible for establishing a detailed project aiming at detecting and minimising all foreseeable impacts. Architectural studies are realised, building materials selected and maintenance processes determined. Thinking of the environment at this stage can help you as an Organiser and event planner avoid subsequent problems.

Advisability of the project

- Real need for a new facility
- Opportunity to use or restore existing facilities
- Sizing of the facility
- Future use and needs after the event
- Use of temporary installations for support facilities when there is no future need
- Financing plan including construction, maintenance and operation costs

17.5.2 Detailed planning

- Avoid illegal building
- Include energy concerns in architectural plans, and especially thermal considerations, in order to minimize the energy required to cool or/and heat the building
- Promote environmentally sound technologies like solar energy, heat pumps
- Plan an environmentally sound operation phase
- Plan compensation and restoration measures if necessary
- Select building material as follows:
- Select materials for thermal performance
- Seek maximum recycled content and recyclable materials
- Choose durable, easily repairable or interchangeable items
- Select materials free of hazardous or toxic products
- Choose products which will not need to be disposed of as hazardous waste
- Use materials that are available in the region
- Plan an architectural integration into the landscape

17.5.3 Construction phase

During this phase, accidents and disruption can occur [accidental release of toxic substances, increased traffic, soil packing or noise]. The sound and rigorous planning of construction can protect not only the environment, but also the workers and the people living nearby.

- Build at a time of the year when animal life and humans will be least disturbed
- Install acoustic isolation if necessary
- Plan soil management
- Use appropriate engines
- Avoid where possible the use of toxic substances
- Plan the management of all substances being used in the work place (storing, use, evacuation and treatment)
- Ensure that the project is in conformity with building plans
- Use environmentally sound construction techniques and materials

17.5.4 Operational phase

The operational phase is almost always the longest in a facility's life. The facility is supplied with water, energy and other goods, the equipment is maintained and the waste removed. The facility hosts training and competition activities. It is possible to adopt a "green step" approach for all these activities.

- Prevent erosion by avoiding fragile areas and reinforcing critical passages
- Avoid wildlife habitats
- Build roads without asphalt
- Promote ecological behaviour among athletes by informing them on issues such as waste collection and protection of fauna and flora
- Saving energy with:
 - Heating, refrigeration and ventilating systems
 - Lighting systems
 - Hot water systems
 - Equipment
- Reducing risks caused by chemicals:
 - Avoid or replace dangerous chemicals
 - Store them carefully
 - Follow instructions for use and local health and safety regulations
 - Ensure that they are disposed of and treated in an environmentally sound manner
 - Ensure ecological planning and management of adjacent surfaces (avoid pesticides and chemical fertilisers, introduce several plant species, etc.)
- Reduce noise and disturbance

17.5.5 Sports equipment

The development of new technologies in sports equipment has led to the use of new substances in the manufacturing processes.

Some of those substances are potentially toxic and can be damaging during the manufacturing, use or disposal of the equipment. A point to keep in mind is the shorter life span of some equipment, which becomes obsolete before being out of order, and generates waste as a result.

The IBSF's objectives are to:

- Reduce pollution due to sports equipment
- Reuse and recycle articles where possible
- Promote environmentally sound equipment and local manufacturing knowledge

We will work closely with sponsors and suppliers to ensure that their products and services are environmentally friendly. We will achieve this by establishing a standard contracting process. Sponsors and suppliers will be encouraged to follow environmental requirements and comply with them. They have to assume their own role in the quest for environment-friendly sport. Requirements for the

manufacturers of our sports equipment and our sponsors include the provision of information on their production processes, their waste management systems, the use of reduced packaging, the reusability and non-toxicity of their products, etc.

We will also encourage companies manufacturing our sports equipment to obtain ISO 9,000 and 14,000 certificates for Quality Assurance and Environmental Management.

With regard to the issue of sports equipment, our member federations and athletes have an opportunity to act at their own level and we will encourage these parties to:

- Choose environmentally sound articles (cotton, natural fibres, etc.)
- Promote the use of locally and ecologically made products instead of imported ones which saves energy, transportation, money and contributes to promoting local knowledge and employment
- Arrange a trading market/day for equipment which is no longer suitable/no longer in use

17.5.6 Transportation

Transportation is required to get to the sports facility and much of it usually takes place in private cars. Transportation contributes to many environmental hazards, particularly air pollution (greenhouse effect, ozone formation at ground level) and related health problems. A reduction in the distances travelled with private cars, incentives to promote public transportation and non-polluting transport together with sound transportation planning could greatly minimise air pollution, noise and disturbance, in sensitive mountain environments well as the extent of land use.

The IBSF's objectives are to

- Minimize transportation
- Promote collective and or public transportation
- Encourage environmentally friendly transportation

This can be achieved by:

- Selecting specific transportation systems which minimise energy use and reduce pollution
- Encourage public transportation systems over private transportation
- Issue tickets for the event that entitle their holders to free public transit rides
- Encourage access to the tracks on foot wherever possible
- Encourage the use of collective transportation for trips to meetings and events
- Organise collective transportation where motor transport is necessary

17.5.7 Energy

Most of the energy used around the world is currently unsustainable. It is largely produced by non-renewable sources such as fossil fuels, which cause a great deal of pollution and are the biggest contributor to global warming and localised air pollution. Many forms of energy production, like nuclear plants or fossil fuel burning, involve some degree of risk to human health or to the environment.

In sports events, energy is required to produce goods that are consumed, to run the event and related facilities, and to transport people and products to the event. As in other human activities, the energy used is mainly produced with non-renewable resources.

The IBSF's objectives are to:

- Reduce energy consumption
- Promote renewable energy and new technologies
- Promote equipment and facilities with smaller energy demand

This can be achieved by:

- Promoting awareness through education at all levels
- Being energy-wise; not only at the facility level but also by such action as switching off electrical appliances when they are not in use
- Checking the lights; and keeping facility lighting to a minimum
- Insulate tracks, buildings and support facilities in order to keep them cool or warm, as the case may be

- Explore alternative energy sources, try to use solar energy to heat water, provide electricity, or both; if available, use small hydraulic plants
- Promote energy conservation measures, select equipment and materials accordingly
- Hold meetings with local energy supply companies to get tips on further energy saving measures

17.5.8 Accommodation and catering

Our events, whether championships or local competitions, attract a large number of persons, i.e. athletes, coaches, organisers, journalists, staff members, sponsors, spectators, who require catering and accommodation for several days.

The IBSF's objectives are to:

- Minimise waste
- Avoid useless construction

This can be achieved by:

- Respecting sanitary conditions
- Reducing packaging
- Recycling goods used
- Using existing facilities (to cook and wash)
- Replacing disposable dishes with reusable ones where possible
- Building temporary facilities and hotels if there is no guaranteed need for them after the event

17.5.9 Water management and sanitation

Freshwater resources are finite and exist in a closed system. Water supply depends on full rivers, lakes, and accessible aquifers and the need for drinking water and irrigation and, increasingly, the need of power for our industries. In most parts of the world, freshwater resources are being subjected to intense pressure. Industrial wastes, sewage and agricultural runoff overload rivers and lakes with chemicals, wastes and nutrients, poisoning water supplies as a result. When practising our sports water is needed to satisfy track building, track maintenance, drinking, washing and maintenance needs. Water is part of our sports facilities.

The IBSF's objectives are to:

- Satisfy the needs generated by the sports event without endangering the water supply of the region
- Protect water resources
- Treat wastewater

This can be achieved by:

- Ensuring that the water provided to the track is of good quality; if not, take measures to purify it:
 - Filter your water
 - Boil the water for at least five minutes
 - Use iodine (two drops per litre) or tablets; only use chlorine if absolutely necessary
- Using water efficiently; turning off the tap when you are not using water is the simplest and most effective way to save water, whether washing your hands, brushing your teeth or shaving; turn on the water only when needed.
- Reducing the use of water required to maintain the track, e.g. the watering water
- Encouraging sound sustainable water resource management programmes including:
 - Water conservation and recycling practices
 - Recycling of treated storm water and sewage effluents
 - Landscape design that decreases water requirements
 - Building and infrastructure design to collect wastewater for recycling
- Waste water management:
 - Ensure the treatment of all wastewater
 - Verify the quality of treated wastewater

- If no wastewater treatment plant is available in your region, build your own sanitary system (possible at limited costs)
- Reuse treated water for field irrigation, bathrooms services, etc.
- Watch out for toxins that may remain in your facility

17.5.10 Waste management

Our facilities and events can generate considerable waste, some of which cause little more than dirt or minor disturbances, while others have a harmful and lasting effect on the environment and human health. Waste is unavoidable, but sound management ensures that waste quantities are kept to a strict minimum.

The IBSF's objectives are to:

- Minimise waste to be disposed of and treated
- Minimise pollution due to waste

This can be achieved by:

- Reducing the amount of materials handled
- Avoiding useless packaging through discussions with your suppliers
- Using as few disposable products as possible at your events
- Choosing carefully the goods and materials handled, in particular:
 - Avoid goods containing toxic substances
 - Choose reusable or recyclable goods
 - Choose goods whose waste can be appropriately treated in the treatment plants located in your region
- Implementing sorting at source (sufficient and separate rubbish bins)
- Dispatching the materials to recycling markets
- Separating hazardous waste from domestic waste
- Treating all waste properly
- Implementing a waste management programme if necessary

17.6 Large-scale Sports Events: Specific Recommendations

Large-scale sports events attract high numbers of people and necessitate the handling of large quantities of goods. This concentration of people in time and place represents a potential danger for the environment. Some measures have to be taken in order to limit the impact.

17.6.1 Sports facilities

- Use provisional installations for the facilities not needed in the long term such as spectator stands and bleachers; encourage improvement of existing facilities
- Use provisional and module equipment which is easy to transform and reuse
- Guarantee to restore provisional facilities and encourage the restoration of damaged sites

17.6.2 Transportation and air quality

- Implement transport strategies to ensure the efficient movement of people (athletes, equipment, coaches, journalists, officials and spectators)
- Establish a transportation concept promoting transport on foot and public transportation
- Establish an air quality plan for the area
 - Monitor emissions
- Encourage major air polluters, including public utilities to take permanent steps to
 - Reduce their emissions prior to the event
 - Establish energy management strategies
 - Encourage transportation fleet operators to take steps to reduce emissions
 - Work with municipal officials to reduce traffic

17.6.3 Energy

Establish an energy management programme for the area taking into account the transportation system and track facilities

17.6.4 Waste management

- Host tracks have the capacity to adopt waste disposal procedures throughout the area in accordance with the event, using techniques that may in turn be applicable to future arrangements; it is advisable to:
 - Reduce the amount of materials handled
 - Establish environmental requirements for the event's suppliers and donors
 - Separate recyclable materials at the source by the waste generator,
- And separate collection
 - Separate household and manufacturing waste at the source
 - Dispatch materials to recycling markets
 - Deal with all waste in a safe and cost-effective manner
 - Implement a comprehensive strategy for materials and waste management
 - Emphasize communication with education
 - Choose products according to cost/performance over their entire life-span

17.6.5 Environmental message to the public

- Internal environmental awareness: all the members of the organisation, senior managers and volunteers alike, should be informed of the broader rationale for their duties.
- External environmental awareness: people of the region must understand the environmental policies and objectives that are being established. Education and communication are essential to the success of sustainable development.

17.6.6 Finances

Include environmental costs in the budget from the outset