

Gauging

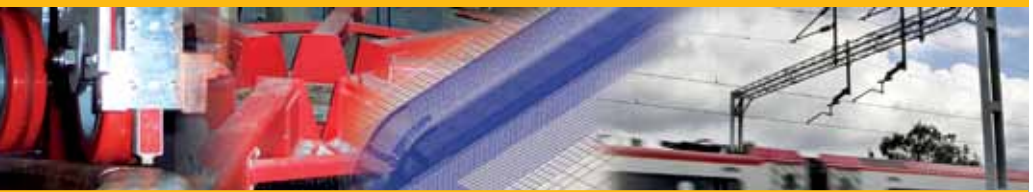

The V/S SIC Guide to
British gauging practice



About this guide

This guide is intended to inform those new to the subject of gauging about some of the intricacies of fitting trains (passenger and freight) on to Britain's railways. Experience has shown there to be many traps for the unwary – assumptions made at an early part of a train building process leading to expensive and costly upstream problems which have been embarrassing to the industry – and unnecessary.

It is also provided as background to those undertaking infrastructure works who may not be familiar with the gauging process. By understanding the context of, for example, measuring bridges and tunnels, better measurements may be taken and expensive mistakes avoided. Measuring the height and width of an arched bridge is of little use when trying to clear a rectangular container.

This guide is intended to assist those intending to run rail vehicles on the British railway network in making sure that they fit. It is not intended to replace expert guidance, but will hopefully lead to more efficient dialogue.

This guide contains a number of illustrations, often taken from Railway Group Standards. Whilst they are correct at the time of writing, standards change from time to time and may make dimensions, etc. shown in this guide obsolete. It is essential that the correct documents are used to determine any values to be used in gauging calculations.

Contents

	Glossary of terms	5
1.	Background	9
2.	Introduction	12
3.	Gauging Processes	13
4.	Vehicle Gauges	14
	Types of gauge	14
	Network gauges	15
	Static gauges	18
	Kinematic or dynamic gauges	20
	Kinematic reference profile	20
4a.	Freight Gauges	21
	Freight containers/swap bodies	22
	Gauge nesting	23
	Static gauges	24
	Dynamic gauges	29
	C1	33
4b.	Passenger Gauges	34
	C3 and C4	34
	UK1	36
	Eurostar (Class 373)	36
	Tilting trains	38
	Effect of loading	38
4c.	Other Gauges	40
	Locomotive gauge	40
	Track maintenance	41
5.	Comparative Gauging	42

6.	Absolute Gauging	42
	Track quality	44
	Crosswinds	45
	The National Gauging Database	46
	Vehicle gauging data libraries	48
7.	Clearances, Track Fixity and Tolerances	49
8.	Hybrid Gauging	53
9.	'European' (or UIC) Gauging	54
	EuroNorm EN15273	56
10.	Platform Gauging	57
11.	Passing Clearances (sixfoots)	59
12.	Electrification	60
	Pantograph gauging	61
13.	Steam locomotives and heritage rolling stock	62
14.	Double-deck trains	63
15.	Gauging surveying	65
	Discrete profile measuring	65
	3D Scanners	66
	Pole and tape	66
	Bridge gauge	66
	Laser profiling frames	67
	Platform gauge	67
	Continuous measurement	67
16.	Risk	68
Appendices		
1.	Gauging flowchart	70
2.	Further information	71
3.	Cover photographs	74

Glossary of terms

This guide uses a number of terms which readers may initially be unfamiliar with. Some are explained briefly below:

BASS501	A simplified methodology developed by the British Rail Mechanical and Electrical Engineering Department for the calculation of vehicle sways and drops.
Cant Deficiency	An imbalance of curving forces and installed cant at a given speed which causes a net force to the outside of a curve.
Cant Excess	An imbalance of curving forces and installed cant at a given speed which causes a net force to the inside of a curve.
ClearRoute™	A program developed by Laser Rail Ltd (now Balfour Beatty Rail) to undertake structure gauging calculations.
Dynamic Gauge	A static gauge further adjusted to account for suspension movements associated with motion.
Equilibrium Cant	The installed cant for where curving forces on a vehicle are in equilibrium.

Gauge	A document or drawing describing how big a train may be, or how small a structure may be. It may include a gauge line.
Gauge Line	A notional line, usually described by points, illustrating the limits of a gauge. The gauge line may require adjustments according to gauge rules..
Gauge rules	A series of standard conditions under which the vehicle or structure must comply with when evaluating against the gauge line.
Kinematic Gauge	Kinematic gauges have been used interchangeably with Dynamic Gauges. More correctly, kinematic gauging methods refer to processes used for gauging in Europe which are different from our own dynamic gauges.
Overthrow	A widening or vertical expansion of the space required by a vehicle for it to pass through the gauge line on horizontally and/or vertically curved track.
PhX Rail	A program developed by DGauge Ltd to undertake structure and electrification gauging calculations and simulations.

Reference Profile	A gauge line, usually defined and adjusted in relation to certain conditions, which describes a notional boundary between infrastructure and vehicles. Favoured in Europe.
Standard Wagon	A wagon that complies with W6a gauge, and which may be used as a carrier for loads complying with other gauges.
Static Gauge	A gauge line and set of rules to be applied when the vehicle is stationary on curved or straight track. In the former case, it is usually necessary to apply overthrow adjustment.
Swept Envelope	The space swept out by a vehicle in motion as seen at a notional position on the track.
VAMPIRE®	A dynamic vehicle simulation program developed by British Rail Research (now Delta Rail Ltd and previously AEA Technology Rail).

1 Background

This booklet is about structure gauging.

Gauging started life very simply – build trains to a standard gauge and infrastructure to a slightly larger gauge and everyone is happy. And so it was when railways were being built across Britain. Everyone was aware of the battle of track gauge – Brunel with 7' 0¼" and the rest with 4' 8½", but many are unaware that each railway company adopted its own 'standard' structure gauge. Standardising (for interoperability) on 4' 8½" track gauge was easy (although painful for the Great Western Railway). Standardising on structure gauge was too difficult (and perhaps unnecessary at the time).



Rainhill Skew Bridge

Early trains were small; it was only once their popularity was established that larger rolling stock was produced (incidentally giving an advantage to latecomers, such as the rest of the world). Fortunately, the difference in size between structures as built and the limiting structure gauge meant that larger trains could be easily accommodated.

Today's railway is very different; a requirement for high-capacity trains and for trains that tilt as they negotiate tight curves (another legacy). Containerised freight (in 9'6" high boxes) presents quite a different problem to small goods wagons. The combination of cross-sectional area, shape, length and speed all place a space requirement on today's railway that could not be dreamed about in Victorian times, although we continue to use much of the same infrastructure.

So we are fortunate that not only were many structures built bigger than required, but the space allowed between trains and structures was large also. This space is known as clearance.

Clearance is provided to accommodate movement of the train as it travels; centrifugal force causes it to sway outwards when going around curves and track roughness causes it to bounce around. As a long vehicle negotiates a curve, it 'cuts off the corner' (as will be observed on roads when a long lorry turns into a junction) – an effect known as overthrow. Clearance is also provided to give a safety margin – to accommodate track maintenance, unknown

situations, tolerances, etc. and sometimes to provide safe walking routes.

As we have built progressively larger trains, we have 'eaten into' the clearance originally provided. Tracks have been moved to accommodate the often conflicting demands of wide passenger trains and tall freight container trains (which don't fit neatly through arched bridges and tunnels). New techniques allow us to understand how much trains move and how much safety margin to provide. Whilst we retain gauges, many include sophisticated analysis to make best use of space.

Gauging is thus a topic that is superficially straightforward, but with the devil being in the detail. This guide seeks to explain some of the mystery, and provide routes to enable running new trains on Britain's railways.

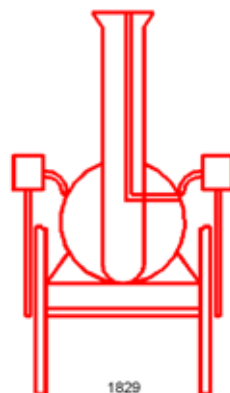

2 Introduction

Gauging, or demonstrating compatibility between train and infrastructure in current parlance, covers a series of techniques that ensure that sufficient space exists around a moving train (clearance) to provide safe operation.

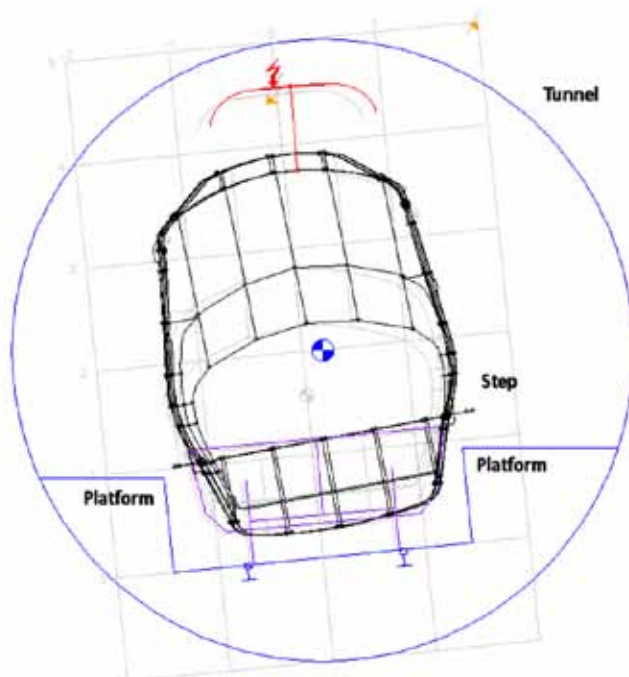

There are simple processes (albeit with subtleties to trip the unwary) and complicated processes. Invariably, simple processes are the cheapest to apply but tend to restrict the size of vehicle that may be run. The complex, computer modeling

processes provide the greatest level of 'fit' between trains and structures (and other trains), but can be expensive and time consuming. The first 'golden rule' of this guide is to choose an appropriate method consistent with what is to be achieved. Introducing similar vehicles to those already in service is an entirely different ball-game to introducing 9'6" freight container traffic, tilting trains or 26m long coaches. This guide follows a logical progression through the processes available, explains their limitations and, perhaps most importantly, the reasons for such limitations.

Appendix 1 provides a flowchart that summarises the following stages to gauge compliance.

3 Gauging Processes

As was mentioned earlier, the simplest form of gauging is by using gauges. These still exist, but are not appropriate to all circumstances. GE/RT8073 defines the standard vehicle gauges used in Britain and how to apply them. If vehicles can be built to standard gauges, then this is the simplest and cheapest method of gauging, as most of the 'clearance' work has already been done.

Should it not be possible to use a standard gauge¹, then the next method to consider is comparative gauging – checking to see whether a new vehicle can

¹ If the vehicle/load cannot be designed to fit within its swept envelope.

run within the 'shadow' of rolling stock already using the route(s).

Finally, the process of absolute gauging – checking the dynamic size of the vehicle against the actual infrastructure along the route – provides a means of maximising the available space but restricts the operation of that rolling stock to that particular route (or network of routes).

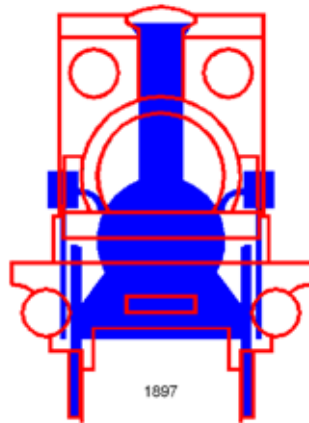

4 Vehicle Gauges

Types of gauge

Historically, great care has been taken to differentiate between freight gauges and passenger gauges.

This differentiation was required to take account of the difference in suspension characteristics to cater for passenger comfort. Passenger coaches tend to have relatively soft suspension and move around a

great deal, whereas freight suspensions are largely 'pragmatic and cost-effective', and allow the load to move less. Whilst this differentiation is important when dealing with true static gauges, once dynamic movements are properly considered, the defining factor is the overall space that they may occupy 'on the move'. There is no reason why, for example, a passenger vehicle could not be built to a gauge primarily designated to freight, provided its movement does not exceed the line defined by the gauge. However, suspension movement translates into ride comfort – a freight suspension would not provide a good ride, and thus, by softening the suspension the vehicle would need to be built smaller to remain within the gauge line.

Note that RGS GE/RT8073 identifies gauges by vehicle type 'W6a is a freight vehicle gauge for wagons'. However, this reflects the origin of the gauge. If any vehicle stays within the W6a gauge (however harsh the ride), it may be used where W6a is allowed.

Network Gauges

Great Britain's rail network has a number of national gauges, which are described in Railway Group Standard GE/RT8073. Vehicles built to comply fully with these gauges may be run where these gauges have been 'cleared' by Network Rail ². Unfortunately,

² The process of 'clearing' vehicles relates to demonstrating compatibility between trains and the infrastructure (as described in GE/RT8270 Issue 2). This process underwrites the suitability of trains to run on the infrastructure.

gauge names may also be used to describe generic types of vehicle or load, even though those vehicles or loads may not actually comply with the gauge. An example would be that W8 (freight) gauge is often used to describe an 8' 6" container. However, it may only be truly compliant with W8 gauge if loaded onto certain suitable wagons. In essence, a W8 vehicle / load is not the same as a W8 hole – nor similarly is a W7 described load the same as a W7 hole, etc.

Let's look in detail at this. To be compliant with W8 gauge:

- 1. The load (which may be anything) when placed on a wagon must be within the static gauge line for the W8 gauge.**
- 2. When the vehicle negotiates curves, the load must remain within the adjusted (for overthrow) gauge line for the gauge.**
- 3. The wagon itself must remain within the gauge lines (bogies and bodies are considered separately as bogies have less dynamic movement than bodies).**
- 4. The bogies must have the same characteristics as those defined for the gauge.**

Points 1 to 3 are self explanatory, but point 4 is often missed. This is why it's important: Britain's rail network consists of many lines constructed by different companies to different structure gauges. Most were not designed for the type of rail vehicles that we are now used to. Perceived wisdom is that

the limiting gauge of a route is defined by the smallest structure, which is actually not the case. The space required to pass a train is dependent on its physical size and also how much it moves on its suspension when travelling. The movement depends on many factors – track quality, speed and curvature being some. A train travelling on straight track will sway less than a train travelling on equivalent curved track, and a train travelling slowly will sway less than a train travelling quickly. These factors are exploited in providing a rail network of a larger gauge than it was designed for – it would be uneconomic to provide space for a gauge with a constant gap between it and the infrastructure (as the railways were originally designed, but with the 'luxury' of being able to build so without economic penalty), so the actual space provided is designed to match the dynamic swept envelope of the gauge. Thus a route defined as W8 compliant will accept vehicles whose dynamic size is no larger than that of a W8 load on a standard wagon.

This has only recently become a problem. Traditional freight wagons and passenger trains had standard coil or leaf spring suspensions that behaved in a similar way. Movement at the top of a freight container whilst running would be around $\pm 75\text{mm}$, and around $\pm 100\text{mm}$ for a passenger train. Modern suspensions reduce track forces and increase comfort by swapping force for increased movement, using low track force (LTF) freight suspensions and air passenger suspensions. In order for such vehicles to comply with the standard gauges, the physical

size of the vehicle or load must be reduced such that dynamically, it remains within the space provided for a vehicle with traditional suspension.

At this point, it is probably worth mentioning what GE/RT8073 is for: A popular misconception is that railway vehicles must be built to one of the gauges described in the document. This is not the case; what GE/RT8073 mandates is that if you wish to describe a vehicle as being of a certain gauge, then it must conform to the standard. Further, the introduction of GE/RT8073 was perceived as introducing changes to traditional gauges. Except for errors and omissions in earlier gauge definitions that were corrected, gauges described in GE/RT8073 are exactly the same as they were when originally introduced. The introduction of movement limits where none previously existed (as stated above, all wagons were deemed to have 'standard' suspensions which did not require definition) was done to characterise those 'standard' suspensions so that introducing novel suspensions that did not behave in a similar manner could also be related to those gauges. Standardisation of the interface allows both vehicle operator and infrastructure manager to understand how much space is required, and to maintain it.

When defining gauges, various terminologies are used, which are explained here:

Static gauges

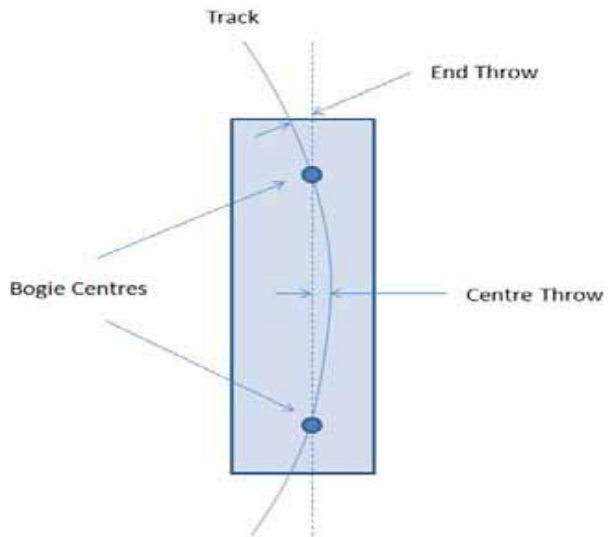

Principle of geometric overthrow on curved track

'Static' means 'not including dynamic movements'. In other words, a cross-sectional profile displaced by the geometrical effect of a 'straight' vehicle sitting on curved track.

Static gauges refer to, for example, the physical size of a vehicle body; in essence the maximum allowable cross-section of the vehicle. Sometimes, a static gauge can include rules that restrict the physical size of the body as it goes around a curve – either by limiting overthrow or by requiring a width reduction. Static gauges normally require a 'standard'

suspension which (combined with the overthrow information) allow the infrastructure manager to determine how much space is required, and on calculation of clearances, whether a vehicle is safe to run.

Kinematic or dynamic gauges

Kinematic or Dynamic gauges refer to the envelope 'on the move'.

These gauges define the space envelope in which the vehicle must operate. It is usual for bogies to be defined as a dynamic gauge – largely because they don't move much – although provision must be made for overthrow in some cases.

Kinematic reference profiles

This is not to be confused with a kinematic gauge. Reference profiles are used in Europe to define a notional boundary between train and infrastructure beyond which neither may intrude. This is described in more detail later.

As can be seen, gauges are far from 'standard'. What is included (and what isn't) is often buried in the detail of the gauge. Also, gauges with similar sounding names, can be very different.

4a Freight Gauges

Freight gauges are described by the 'W' (wagon) series of gauges.

The following diagram shows the upper static gauges defined by GE/RT8073. These shapes relate to a standard BR wagon profile (largely limited by the high number of arch bridges on the network), various flat topped and 'S' profile container and swap-body loads. From this, the lack of numeric nesting can be seen clearly. Dimensions are in mm from track centre and above rail level.

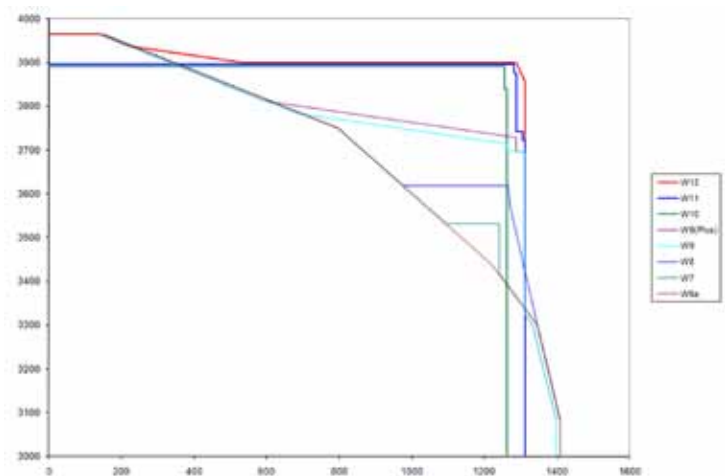

Comparison of W Gauges

Freight containers/swap bodies

Much of today's freight is containerised, or in the form of swap-body units.

Containers fall into standard sizes, largely defined for the marine sector and to ISO standards. Most of today's containers are of standard width of 2500mm, but refrigerated containers ('Reefers') may be 2600mm wide, although some are 2550mm wide as a result of more efficient insulation. Heights vary considerably, but the most common are 9' or 9'6" – the latter being the largest practical height on Britain's railways, although taller containers can be accommodated by using lower deck wagons. Typically, 9'6" x 2500mm loads are referred to as W10 and 9'6" x 2600mm loads are referred to as W12.

Swap bodies generally conform to European standards, and conform to an 'S' profile, being a measure of height and width. Swap bodies may be either flat topped or tent topped. GE/GN8573 contains a table of S codes and their dimensions.

It is worth noting that gauges for containers contain allowances for the type of fixing used to locate the container on the vehicle deck. UIC spigots allow up to ± 12.5 mm of movement and BR 'Twistlock' fastenings allow for up to ± 6 mm of movement. Gauge definitions should indicate what assumptions are made with regard to fastenings.



Damage to arched bridge due to a true out-of-gauge load

Gauge nesting

W6a sits within W7, and W7 sits within W8. That's where it stops – part of W8 protrudes outside of W9. Nesting refers to a numerically larger gauge being progressively larger than the one with the previous number in the series. However, the concept of nesting falls down when the network cannot accommodate ever increasing size, or different rules are applied. W10 gauge is taller than W9 gauge, but W9 is wider, for example. Further, the larger gauges cannot be accommodated with the same degree of space conservatism as the smaller gauges as they tend to be defined dynamically to fit within the same physical space. The following descriptions of each gauge will, hopefully, bring some clarity.

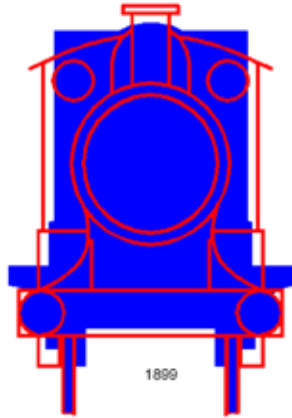

Static gauges

W6a

W6a is the 'workhorse' gauge of the British railway network. Following nationalisation, a standard wagon gauge (W5) was introduced in 1951, being a gauge that would fit virtually anywhere on the new 'interoperable' railway. This was replaced by W6 as a refinement, which was then replaced with W6a once issues regarding clearances to third rail electrified track were identified. It remains, to this day, the freight gauge with maximum acceptance (although not 'go-anywhere'). Note that a W6a hole will always accommodate a W6a wagon.

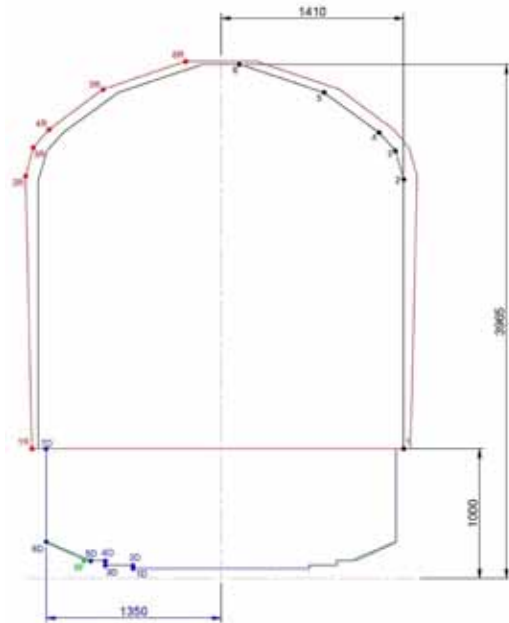

W6a Gauge

As can be seen from the diagram, there are three lines; black, red and blue. The black line is the original static gauge – the line inside which the body of the vehicle must be. Coordinate details are given in GE/RT8073. However, W6a is designed for non-bogied wagons with axle spacings of 12.8m (42'), and 18.3m length (60'). Knowing this (which allows overthrow on curves to be calculated) and that the standard suspension moves no more than 100mm (4") allows the infrastructure manager to provide safe clearances. If the wagon is built longer than 18.3m, or the axle spacings are different (or even that it runs

on bogies³), then the body width must be reduced to accommodate the increased overthrow that would result. Formulae presented in GE/RT8073 describe how much width reduction should be applied.

For the vehicle builder, the process of building a vehicle body is to keep it within the black line (with any necessary width reductions due to its length). Using a 'standard' bogie will satisfy the dynamic requirements (or adjusting the vehicle body size to accommodate additional movements due to, for example, low track force bogies).

The red line is basically for the benefit of the infrastructure manager. If the infrastructure is clear (to the required clearance) of the red line (which represents the extreme movement of the vehicle body), then the structure may simply be defined as clear. If the structure is not clear of this line, then calculations must be done (again using the standard suspension) to work out exactly how much movement will occur at the speed and cant deficiency (or excess) that will occur as the vehicle is passing. This latter process, known as absolute gauging, allows maximum use to be made of the infrastructure space available. Using the red line solely would mean either traffic restrictions or rebuilding of the structure.

The blue line represents the dynamic gauge for the lower sector. The bogie (or anything else in this area)

3 Bogies increase the overthrow towards the centre of a curve and decrease the overthrow towards the outside of a curve. This effect can be around 5mm for a typical bogie on a 160m curve.

must fit within this line. The lower sector (or platform) gauge is discussed later.

Note also the green line in the bottom corners. This is allowed for maintenance machinery which may require parts to be closer to the infrastructure for measuring purposes, but which would operate in a higher risk regime than allowed for other parts of the vehicle.

W7

W7 was originally known as W6a exception gauge for 8' containers. Basically it is the same as W6a, but with a notch to accommodate a rectangular box. Apart from the adjustment of the gauge line, rules for W7 are the same as for W6a.

W8

As W7, W8 (known originally as W6a exception gauge for 8'6" containers) is W6a with an even bigger notch. It also shares W6a rules.

W9 and W9 Plus

W9 was originally known as SB1c, a swap-body gauge. This gauge was developed to facilitate the passage of containerised freight between Britain and Europe. It is also described in UIC document UIC506.

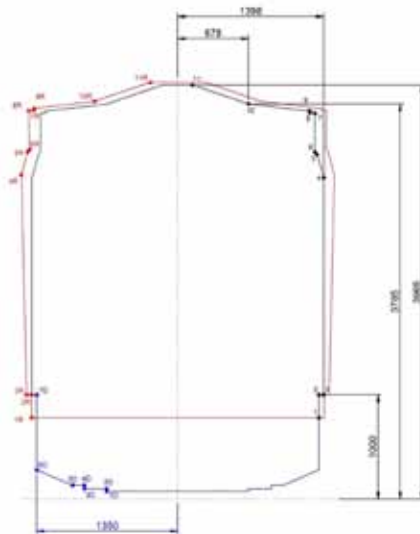

W9 Gauge

The lower (blue) gauge line is the same as W6a. As with W6a, the black line is the static gauge and the red line is the maximum infrastructure gauge. The static gauge is designed to accommodate a variety of loads (Network Rail publish these).

W9 gauge refers to bogied wagons with a bogie spacing of 14.02m, although the wagon length is the same (18.3m) as W6a.

W9Plus gauge is a recent addition to the gauge suite, which includes a small additional area to allow slightly larger (but numerically significant) S coded containers to be accommodated (S32 loads on 945mm deck height wagons and S45 loads on 825mm deck height wagons).

Dynamic gauges

A dynamic gauge is one where the gauge line may vary depending on input conditions, such as speed and cant.

In the GB dynamic gauges have traditionally been associated with computer modelling; in particular the W10, W11 and W12 freight gauges are dynamic. However, the ability to adjust a gauge line in relation to cant deficiency, for example, means that a larger gauge results on straight track than would result on track with high cant deficiency. This generally allows larger vehicles to run through the network, and explains why vehicles built to a static gauge may not demonstrate compatibility with the infrastructure where the space required to accommodate movements associated with full cant deficiency cannot be provided, even if these movements do not occur at every location.

In theory, best use of space is obtained by having gauges which adjust for speed, cant and curvature. However, relating gauge line to cant (deficiency or excess) and curvature provides much of the benefit without being overly restrictive of suspension design.

Revising the suite of GB gauges as dynamic gauges is under consideration, and RSSB research projects T977 and T978 are, at the time of writing, developing dynamic gauges to specify lower sector and suburban vehicle gauges dynamically. In the meantime, the versions of the dynamic gauges shown in GE/RT8073 are simplifications of these dynamic gauges – they

include a static gauge line and limiting dynamic gauge lines – which, if applied would not provide the benefit of dynamic analysis. However, if the static load can be retained within the gauge line, standard wagons are used, and the infrastructure is cleared to the dynamic line, this provides a cheap form of gauging many structures.

W10

W10 gauge relates to the transporting of 9'6" high x 2500mm wide container loads on a specific set of wagons. This represents the mainstream of GB intermodal freight. W10 only defines the load gauge – it is required that the wagon itself should be within W6a gauge.

W10 gauge refers to bogied wagons with a bogie spacing of 14.02m, although the wagon length is the same (18.3m) as W6a.

W12

W12 gauge relates to the transporting of 9'6" high x 2600mm wide containers (often refrigerated) on 945mm deck height wagons, as well as a number of other loads, on a specific set of wagons. W12 is recognised as being technically challenging to provide. Whilst the W12 gauge has been represented by static diagrams in GE/RT8073, in practice it is defined by a suite of several thousand gauge lines representing a wide range of infrastructure conditions. Again, the wagon needs to be within W6a.

W12 gauge refers to bogied wagons with a bogie spacing of up to 15.288m, although the wagon length is the same (18.3m) as W6a.

W11

W11 was developed after W12 (explaining why it is described after W12) because W12 infrastructure is very difficult to provide in Britain. W11 was created to accommodate 9'6" x 2550mm containers, being easier to provide than W12 but providing more space than W10 for an emerging market. As W10 and W12, it is only applicable to a limited set of wagons, which themselves must comply with W6a. In future-proofing infrastructure upgrades, Network Rail has elected to provide W12 more generally. Coupled with the relatively small volumes of 2550mm wide container traffic, this means that although an approved gauge, it has not been adopted by the industry and no routes have been cleared for the passage of W11 traffic.

W11 gauge refers to bogied wagons with a bogie spacing of 14.02m, although the wagon length is the same (18.3m) as W6a.

Effect of bogie centre changes on overthrow

In noting the variation of bogie centres, it is worth considering the effects of changing bogie centres, and in particular how this affects containerised freight:

As bogie centres increase, centre throw (overthrow to the inside of the curve) will increase. If the bogies are moved towards the ends of a wagon, then end throw will decrease. For a given change in bogie centres,

end throw will change more than the centre throw. For balanced end and centre throws, axle spacing should be (wagon length) / $\sqrt{2}$. For most wagons, particularly when loaded with less than 3 x 20' container units⁴, centre throw is usually dominant.

In the following diagram, the effect of varying wagon bogie spacing and the number of containers carried can be seen clearly. Only when carrying 3 containers does either vehicle exhibit overthrow towards the outside of the curve. At no point does end throw exceed centre throw. This refers to the overthrow of the containers, and hence the effect of clearance on overhead structures.

4 If only 2 x 20' containers or less are loaded, then there is virtually no end throw.

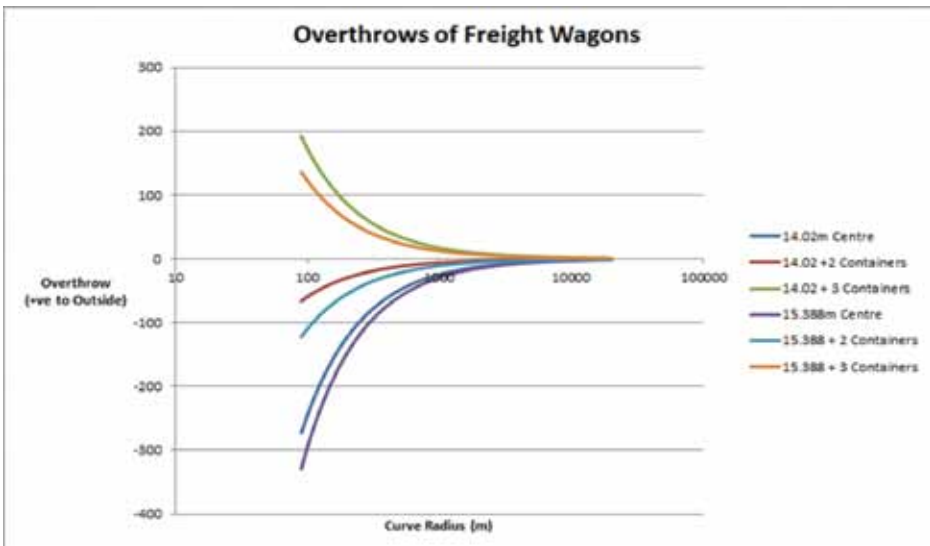

4b Passenger gauges

C1

As W6a is the workhorse of freight gauges, C1 is to passenger gauges – or coaching stock as the C refers to. C1 gauge is for nominal 20m (65ft) coaching stock (although there have been versions for shorter vehicles) with conventional metal spring suspensions and 14m nominal bogie centres.

As can be seen, this gauge consists of many lines. To simplify this, consider the black line as the static (build) gauge, the purple line as the upper dynamic (limit) gauge and the blue line as the lower dynamic gauge described earlier. The outer lines enclose areas for items described as frangible, such as door handles, ventilators, etc. In other words, those items that were considered inconsequential if they should fall off or be struck by a passing train. In today's risk aware railway, it is unlikely that such appendages would be considered, but are retained in the gauge for clarity for heritage rolling stock.

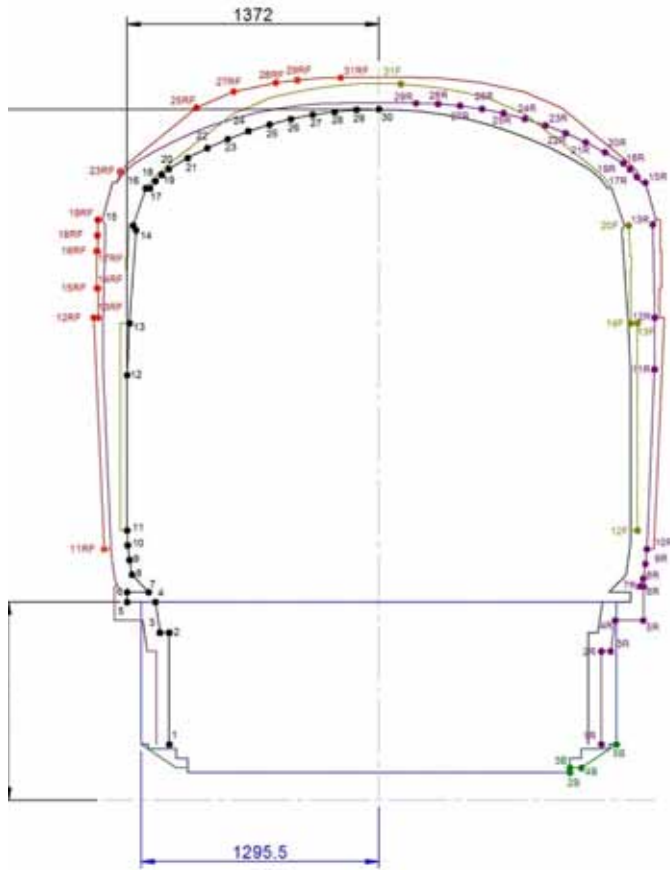

C1 Gauge

C1 Appendix A

C1 Appendix A describes basic 20m rolling stock with air suspension. In reality, although the static profile (being a derivative of C1, using some of the 'frangible' space) has been used for rolling stock (which has been labeled as such), it would be very difficult to build a vehicle truly compliant with C1 Appendix A which could practically run. Air suspension allows significantly more body movement than conventional steel springs. Accordingly, to provide adequate infrastructure space to accommodate suspension movement in all locations would be prohibitively expensive, and the process of dynamic gauging (incorrectly known as kinematic envelope or KE gauging⁵) was developed to allow the introduction of air suspended vehicles (see section on absolute gauging). Further, modern bogies for 100mph running or greater generally have bogie yaw dampers, inconveniently located (from an infrastructure perspective) in the most critical area of clearance between train and platform. C1 Appendix A provides limited space for this.

Where rolling stock is compliant with a gauge, this is often stenciled on the vehicle end. However, there are examples of rolling stock labeled as C1 Appendix A when it does not actually comply with this gauge (indeed no GB routes are truly cleared for C1

⁵ A kinematic envelope, or KE, is the piece of paper describing, by formulae, the expected vehicle movements under conditions of speed and cant (excess or deficiency). The process by which this is applied is known as dynamic gauging.

Appendix A, but are cleared to a dynamic equivalent). Vehicle labels should not be used for gauging purposes.

C3 and C4

Mark 3 coaches are labeled C3 restriction and Class (Pendolino) trains are labeled C4. These do not refer to any standard gauge.

UK1

UK1 was defined in response to European Interoperability requirements for the High Speed Technical Specification for Interoperability, in consideration of the gauge required by an interoperable train operating on the three principal main lines in Great Britain as an alternative to the European GB reference profile generally mandated in the TSI. This defines the GB special case. UK1 was developed from the largest sized vehicle that could pass along these principal routes without consideration of diversions or depots. Considered capable of fit, but operationally unworkable⁶, UK1 provides guidance to the ultimate capabilities of these routes. In practice, considerable work has since been undertaken to consider a new 'Inter City Express' gauge which is technically robust and would be a

⁶ UK1 is required for certain designated main line routes. However, to provide an operational service, diversionary routes and depots are required. Since diversions and depots relate to service provision, and may be extensive, UK1 gauge has been developed around only the designated routes.

worthy successor to UK1 in due course.

Eurostar (Class 373)

The Eurostar is a TGV (Train à Grande Vitesse) built to the restrictive British gauge available when the Channel Tunnel was opened. Gauging of this train should be performed using the document MSER42 issued by Eurostar.

Eurostar gauge is a dynamic gauge (defining the limits of vehicle movement) but expressed as a composite gauge for the entire train. Key points (including cantrail, waist, solebar, yaw damper and airbag skirt) are defined by their individual overthrows and sways (and drop in the case of the airbag skirts), which are joined to form the composite gauge.

Two types of Eurostar are defined – Three Capitals and Regional. The latter differ in their airbag dimensions such that they are able to accommodate normal British platforms (on the original Three Capitals [Boat Train] route, platforms are set back beyond the normal dimensions (see lower sector structure gauge)).

Routes from London Waterloo (and North Pole Depot) – Folkestone were originally cleared for Three Capitals stock, and routes from London to Manchester and Leeds were additionally cleared for Regional Eurostar stock. Regional services were never introduced, except for a temporary Leeds – London Kings Cross service which no longer runs. However, these routes remain cleared for regional

Eurostar.

An anomaly between MSER42 and current practice is that it provides two models of Eurostar; one suitable for 'British Rail' in general and one suitable for the East Coast Main Line. At the time of writing MSER42, the East Coast Main Line had recently been renewed and was considered to be of the highest quality. This differentiation is no longer valid.

Tilting trains

The introduction of Class 390 (Pendolino) and Class 221 (Super Voyager) provided an interesting gauging challenge. Tilting trains have additional degrees of freedom between the bogies and bodies that require them to have more space to operate in unless the bodies are reduced in size⁷. The additional space required is a complex function of speed and cant deficiency determined by a computer algorithm, but perversely means that they tend to sway more to the inside of curves on increasing cant deficiency, when normal trains would sway towards the outside of curves. Gauging models of these trains have been constructed and must be used for the calculation of clearances, as calculation by hand will only give approximations. Where tilting is authorised, it is necessary to consider tilt active, tilt passive (where the tilt is disabled), and possible tilt hard failure.

⁷ Both Class 390 and the 'Voyager' range of vehicles (and Mark 4 coaches) are designed to accommodate a small degree of body tilt within what would be considered the normal gauge, leading to reduced internal space.

Terminology associated with tilting trains (and in particular manufacturers) tends to differ. For example, when in non-tilt mode a class 390 is known as 'tilt passive' and a class 221 is known as 'tilt locked out'.

Effect of loading

Trains behave differently when they are empty (Tare) and loaded; both cases must be considered. Typically, vehicles are tallest under tare condition and sway most under loaded conditions. Also the lowest condition must be considered in terms of clearance to platforms and under structures. This would generally be the loaded condition, but in the case of air suspension vehicles would be in the additional situation of air bag failure, a condition often referred to as Crush Deflated. Thus, for modern passenger rolling stock, it would be necessary to consider Tare Inflated (highest), Crush Inflated (widest at cantrail) and Crush Deflated (lowest) conditions. Since air bag failure occurs infrequently, reduced clearances to deflated conditions are considered acceptable. With freight, usually Tare and Laden are considered.

The crush loading definition will depend on the type of rolling stock. It is usual for inter city rolling stock to be less heavily crushed than a commuter train. Vehicle standards define various loading environments; generally maximum service condition loadings are applied when analysing gauging performance. Occasionally, an additional condition of Tare Deflated may be required to accommodate vehicle moves into depots where the air suspension is inactive and there

will be no passengers. This is less restrictive than Crush Deflated, and may mean that additional space is available for vehicle design by segregating depot only routes.

4c Other gauges

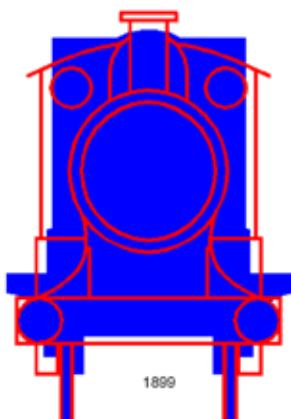

Locomotive gauge

Locomotive gauge was originally developed to achieve go anywhere availability, and as such is more restrictive of vehicle size than other gauges. However, with various infrastructure changes (which have not restricted the opportunity to run existing locomotives) locomotive gauge no longer holds a 'go-anywhere' status. Also, as locomotive design has moved towards more powerful machines (many traditional light locomotive designs have been displaced by

multiple units) the track loading characteristics (Route Availability or RA) prevent them from going anywhere, anyway. Thus, it could be argued, that new locomotives could usefully be built with reference to other means of gauging, such as applied to conventional rolling stock (such as dynamic gauging).

Track maintenance

Track maintenance vehicles require as near to a 'go-anywhere' gauge as possible and are usually built to a 'special case' of W6a which allows access to extensions of the gauge which are not available to 'revenue' vehicles. Typically, these areas are used to attach sensors and other appendages which would cause no damage to the infrastructure in the event of a strike (although it may break the maintenance machine).

Unfortunately, there is no true 'go-anywhere' gauge; W6a has many exceptions, especially in non-core parts of the network. A dynamic version of W6a has been produced which relieves many of the exceptions on lower cant deficiency/excess situations, and is in the process of publication. It will be available from RSSB (Track Engineer). By adapting this gauge (for example by including actual vehicle profiles rather than the gauge profile), it may be used for absolute gauging purposes in those areas where W6a is unable to pass. However, clearance by this method (ie, an adapted W6a profile) would not infer permission for other W6a vehicles to run.

5 Comparative Gauging

Comparative gauging provides for the certification of compatibility by a process of demonstrating that new rolling stock can be operated in 'the shadow' of rolling stock which already has certification on the routes that new rolling stock is to be operated on. In practice, this would be done through computer simulation, where the dynamic swept envelope of candidate and comparator vehicle would be compared over the range of speeds and cant deficiencies / excesses that would be experienced on the route.

It is important to note here that comparison methods must be similar; demonstrating that a candidate (new) vehicle modeled with VAMPIRE® fits within a comparator vehicle modeled by BASS501 would not be acceptable.

6 Absolute gauging

Absolute gauging is nothing to do with gauges, although it uses the same principles that are used by Network Rail to determine where standard gauge vehicles may run economically.

In absolute gauging, the actual space required to run a vehicle along a route is compared with the actual size of structures and the position of adjacent tracks along that route. As early as 1985, hand-calculating techniques were developed (BASS501) which enabled the calculation of simple vehicle body sways from speed and cant deficiency or excess from which

the dynamic space required could be calculated and compared to structures along a route⁸.

Since then, increasingly sophisticated computer modeling systems have been developed (examples being ClearRoute™ and VAMPIRE®), together with more accurate tools for measuring the actual size of infrastructure, which now make the determination of fit an accurate process, albeit numerically intensive. It is through the use of these systems that tilting trains, large containerised freight trains and modern commuter rolling stock can be run – this would not have been possible through the use of gauges without vast expenditure in providing additional (and arguably unnecessary) space to accommodate them.

Of course, whilst the cost of enlarging infrastructure has been avoided, this has been at the expense of increased cost in analysing where trains may run. Successive introductions of new rolling stock lead to incremental improvements in route capability – limiting structures are enlarged – and other renewals replace heritage structures with those more appropriate to present (and future) needs.

Computer analysis has become almost a ‘black box’ technology; arguably ideal in the sense that if a set

⁸ The term ‘kinematic envelope’ originated from this work. A kinematic envelope is, technically, a calculation sheet (drawing) which describes the calculations and values necessary to determine sways and drops of a moving vehicle on straight track at different speeds and cants. In order to determine the actual space occupied by the vehicle (the swept envelope), overthrows on curves must be considered.

of (complex) rules are met, then a vehicle is OK to run. However, whilst the industry has grown to accept this, it is increasingly being recognised that in order to apply a 'black box' series of rules, then there is little scope for engineering judgment and more particularly that the 'answers' themselves are black and white. In particular, whilst such systems have led to a dramatic improvement in capacity to that provided by simple gauge rules, there is, nevertheless, some conservatism remaining.

The V/S SIC and RSSB have commissioned research into improving understanding of the remaining conservatism (particularly in projects T373 and T670 covering uncertainty) and, it is hoped, that the future use of advanced analysis techniques may assist the release of further space currently reserved to accommodate unknowns.

Track Quality

In performing simulation, it is important that vehicle movements are determined using simulated track of an appropriate quality. Network Rail publishes standards within which track of various categories is maintained. Gauging should be undertaken using track files at these limits, rather than at 'typical' values to ensure that clearances derived are those representing worst case.

RSSB has commissioned a series of reference track files (solely for gauging purposes) that are available from Network Rail for use in simulations (contact

Network Rail's Senior Gauging Engineer).

Track measurements consist of a design, or maintained, alignment which includes a measured roughness. An important consideration in using reference track roughness files is that such roughness should not generally be added to the measured roughness contained within raw track surveys. When calculating cant deficiency or overthrows, the underlying design geometry should be applied rather than that calculated instantaneously from simple consideration of measured curve radius and installed cant. Failure to consider this may result in erroneous clearance results.

Crosswinds

Crosswinds cause vehicles to sway, and for this reason should be considered on exposed locations. Whilst no methods are mandated for doing this, GM/RT2142 (Resistance of Railway Vehicles to Roll-Over in Gales) describes a methodology whereby crosswinds may be considered as an equivalent cant deficiency and may thus be used to determine vehicle sway. This topic is complex and is best left to experts. Essentially, if crosswinds are present, more clearance is required. Fortunately, for the majority of structure gauging situations, significant crosswinds are unlikely to be present. There is no requirement to consider a horizontally opposed hurricane in a tunnel, for example, as urban myth would have it.

Some vehicle gauges contain profiles under

conditions of maximum cant deficiency and maximum wind loading. These have been provided for the guidance of infrastructure managers for the provision of additional clearance in exposed locations. It is generally acknowledged that wagons built with established bogies carrying standard loads will remain within this envelope.

The National Gauging Database

An integral part of determining the fit between train and infrastructure is knowledge of the size of that infrastructure. Whilst it may be expected that a 'national gauging database' (NGD) would tell you where various gauges may be run, this isn't the case. In fact, the NGD contains several hundreds of thousands of structure profiles for the infrastructure of the 'whole' of England, Scotland and Wales. It is only in the last ten years that the task of compiling such a database has been undertaken. Prior to this, the introduction of any new rolling stock to be gauged absolutely required teams of surveyors to spend weeks, months or years measuring the structures before analysis could be undertaken. Not infrequently, different teams would be measuring the same routes for different clients. Under instruction from the ORR, Railtrack (now Network Rail) undertook to compile such measurements into a single database – a process that continues. However, track moves, structures deteriorate and measuring techniques improve, meaning that the collation of

such a database represents a constant task rather than a one-off event. Much effort is put into keeping a national database up to date through a cycle of re-measurement and to the higher levels of accuracy and integrity provided by modern measuring systems. Whilst the NGD covers the whole country, it is only in more recent years that the high quality of data now expected has been capable of being collected and it must be accepted that, on occasions where analysis is to be performed to modern standards, a degree of re-measurement may be required. Without this, potential train size can only be smaller.

One area of concern frequently raised is age of data. Some measurements on the database are quite old. However, this is only of concern for structures whose clearance is 'tight'. There is no real reason to measure structures that are well clear (such as motorway bridges, etc.) on as frequent a schedule as those which are close to the track. Similarly, the need to re-measure on the basis of line speed (as is used in some countries) is less appropriate in GB. GC/RT5212 is frequently misunderstood in this context, in that it provides a mechanism of structure re-measurement based upon the clearance that existed at the time of measurement. This value is reduced annually until the resultant (albeit contrived) clearance falls below an attention threshold. Unfortunately, this 'age tolerance' which is based on the assumption that the track is moving, year on year, at the fastest rate possible is frequently used to suggest that data is too old. In practice, clearances

are most likely to be adequate (as could be confirmed by judgment of the location) but indicative of the need for re-measurement⁹.

At the time of writing this guide, Network Rail is reviewing track stability control measures, which may lead to a review of the rules applied to assumed track movement and the rates of that movement.

Vehicle gauging data format

Where absolute gauging is performed it is necessary to build a 'model' of vehicle gauging data which can be used for analysis. Once compatibility has been demonstrated using this model, it is important that the data be lodged¹⁰ in order that subsequent changes to operating routes can be tested and the infrastructure maintained to allow continued passage of the vehicle. It is also important that, should any modifications be made to the vehicle, the information lodged is also updated. At present, this 'gauging portfolio' forms part of the evidence of compatibility.

This vehicle data is also necessary to perform comparative gauging, although in this context there are commercial considerations. Whilst a number of

⁹ An example is given of a platform measured 10 years ago, whose clearance had been reduced by 15mm per year, thus rendering it 100mm foul when 50mm was required. In practice, track in platforms, although considered to be medium fixity, will not move towards the platform as calculated.

¹⁰ Information to enable compatibility between trains and the infrastructure (a gauging portfolio) should be submitted to Network Rail.

'common domain' models exist, most 'modern' rolling stock has been analysed by vehicle builders who retain intellectual property rights for this data (due to the cost of generating it). Experience has shown that manufacturers are willing to make this data available for the overall benefit of the industry, or by commercial arrangement.

In building the gauging 'model', there is a minimum set of parameters that need to be provided. To date, much of this data has been presented in a variety of formats which must be manually input into computer programs. This process is prone to error and misunderstanding. Industry good practice has been assembled into the *V/S SIC guide to Vehicle Gauging Data (Format and Guidance)*, April 2011 (RIS2773) which provides a standard template for gauging data, together with guidance into assembling the necessary data. This is in the form of a workbook, which may be read by a computer program and thus avoid manual input errors.

7 Clearances, track fixity, and tolerances

'Clearance' has traditionally been considered to be the equivalent of a safety factor – a place where unknowns and comfort may be lodged. However, today's railway is more controlled than 50 years ago when the Railway Inspectorate 'Blue Book' required a gap of 200mm - 250mm between a vehicle gauge and a structure. GC/RT5212 provides the information for today's clearance regimes.

Firstly, there is no such thing as a minimum clearance, except that it should be positive. Clearances may be described as 'Normal', 'Reduced' or 'Special Reduced', but this is simply to categorise the control regime that must be applied in order to preserve safe clearance. When GC/RT5212 was published (1983), it drew a distinction between clearances, tolerances, allowances and unknowns – clearance became the additional space requirement for unknowns once the other factors had been taken into account, and accordingly reduced considerably from previous values. This was done through the introduction of a concept known as 'effective track position'. Once all 'knowns' are considered, clearances of greater than 100mm are considered normal, greater than 50mm are considered reduced and greater than 0mm are considered 'special reduced'.

The latter category may rest uncomfortably, since there is no obvious space for unknowns. However, this brings us to the consideration of the nature of where a moving train will be in relation to a tunnel, for example. There is a common view that gauging is 'absolute' as the name given to the process suggests. However, it is truly a statistical measure – trains 'rock and roll' and the extreme positions used for gauging calculations are only likely to be encountered in

around 1.7% of encounters¹¹. Similarly, parameters such as track fixity – the degree of anticipated track movement – represent extreme movements than may, in practice, never occur. Even more comforting is that the probability of the extreme tolerances 'stacking up' constructively (ie all adding together in the same direction) becomes an exceedingly low probability. Thus, to all intents and purposes, there remains a significant degree of comfort in the 'absolute' values calculated.

A major factor in the positioning is that of track fixity. Permanent Way is anything but permanent. Ballasted track moves with time, temperature and the passage of trains. Standard ballasted track is considered to be low fixity. At any given time in its maintenance cycle (the time between maintenance events) it may be anything between $\pm 25\text{mm}$ out of lateral alignment, $+25\text{mm}$ out of vertical alignment and have $\pm 20\text{mm}$ of crosslevel error. Remember, these are absolute positions, not the variation from one position to the next which will be very much smaller. The above errors will be imperceptible in terms of ride, but are significant in terms of position.

Thus, if we are considering normal ballasted track, with low fixity, the above values (as a minimum)

¹¹ Mean ± 2.12 standard deviations of movement are used to determine the 'absolute' vehicle movement used in gauging calculations. If the probability distribution were normal, this would provide for 98.3% of events providing lesser movement towards a structure. However, the distributions have been demonstrated to be slightly 'abnormal' giving a marginally lower value in practice.

would be added to the size of the swept envelope¹². Network Rail would maintain the track before these values arose.

Medium fixity track moves less, and is generally associated with some form of fixing – glued ballast, struts against platform faces or constrained by bridge girders, say. In certain circumstances, track in platforms may be considered medium fixity in the direction of the platform where there is natural constraint¹³.

High fixity relates to track that doesn't move – slabbed track, for example.

Thus, depending on fixity, a clearance regime will determine the control measures put in place by Network Rail. The more demanding the control measures (for those places where clearances are below normal), the more expensive the control regime.

A word on tolerances – it was noted that the whole process of gauging is statistical, and that 'conservatism' exists in the use of absolute values and that tolerances and allowances are added constructively. Two RSSB projects – *T373 Uncertainty in structure gauging* and *T670 The*

12 Generally +15mm -10mm would be applied to vertical alignment, since maintained track quickly settles. Crosslevel error is considered to be 50% static and 50% dynamic (i.e. 50% is already considered in the vehicle movements), so only 50% is applied to the track.

13 Track maintenance is used to effectively 'reset' clearance when required.

effect of accumulative tolerances on vehicle gauging considered this very effect and concluded that advanced statistical modeling could provide the opportunity for providing a gauging regime of calculated risk but which reduced the cumulative tolerances applied. Gauging risk is explained more fully later.

8 Hybrid Gauging

Hybrid gauging is the term used for a combination of techniques aimed at clearing a vehicle most economically. An example would be the use of a comparator vehicle (or vehicles) to clear part of the vehicle (such as the body) and absolute gauging to clear footstep / yaw damper arrangements.

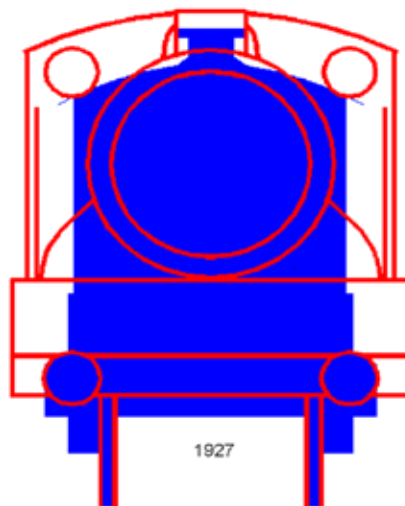

9 'European' (or UIC) gauging

Gauging in mainland Europe is predominantly to UIC (Union Internationale des Chemins de fer) methods. These are described in a series of leaflets, known as the UIC 505 series. In essence, European gauging is to a 'reference profile' process – quite different to anything used in Great Britain. Unfortunately, one 'base profile' is known as GB, but it has absolutely nothing to do with Great Britain.

A reference profile is neither a vehicle gauge nor a structure gauge. It represents a notional boundary between the space occupied by rolling stock and the space that may be occupied by infrastructure. Common UIC reference profiles are GA, GB, GB1 (also known as GB+) and GC. GC is the largest of these. Most European rolling stock is built within the GB reference profile.

A common misconception in dealing with these reference profiles is that they should be treated similarly to British gauges and as such that they may be readily compared. Unlike British gauges, which are bounded by clearances, UIC reference profiles are reduced by various parameters in determining maximum vehicle size, and increased by various parameters in determining minimum structure size. Typically, reference profiles include certain base conditions such as the overthrow for 250m radius curves and 50mm cant excess or deficiency. GE/GN8573 describes the methodology for applying reference profiles in more detail.

In Britain, the HS1 route is cleared to GB1 gauge on

passenger sections and to GC gauge for the through freight route. It is proposed that HS2 would be built to GC gauge.

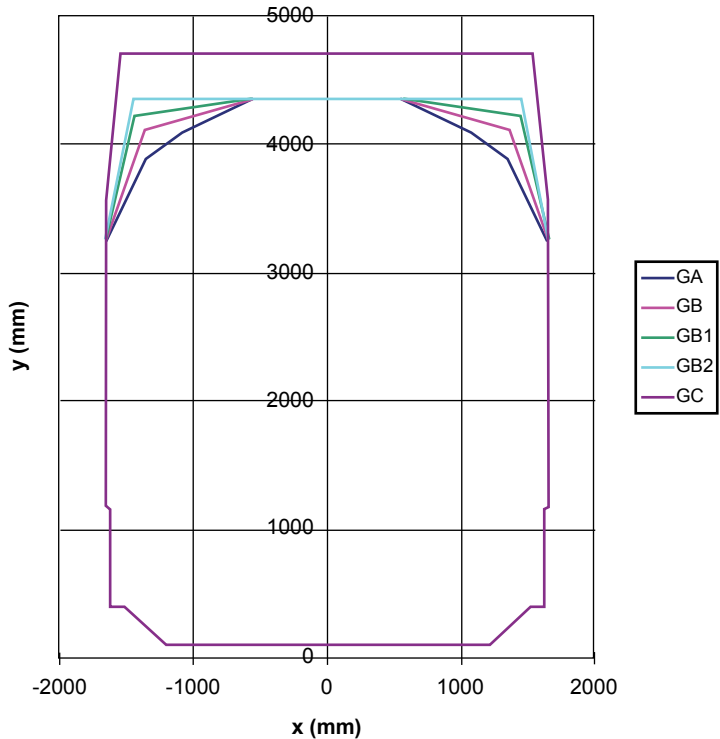

European (UIC) reference profiles

EuroNorm EN15273

As interoperability across Europe is sought, cross-European railway organisations (including GB) are co-operating to produce a EuroNorm for gauging which is intended to replace national standards. In essence, there are three substantive parts; Part 1 being an introductory text, Part 2 covering vehicle aspects and Part 3 covering infrastructure aspects. Other parts contain a gauge catalogue and worked examples of calculations.

EN15273 attempts to bring all European gauging methods into a common document using common definitions. At the time of writing, significant progress has been made but the documents are not, at this stage, sufficiently robust to replace National rules in GB or indeed other European countries.

10 Platform gauging

Platforms are in an area controlled by a lower sector structure gauge (GC/RT5212). This gauge defines where infrastructure such as platforms, bridge girders and similar low-lying hardware should be. The gauge serves a number of purposes:

- It limits where a platform (or other structures) may project into the swept path of a train
- It provides a nominal reference point for calculating stepping distances
- It indicates where objects should be where they are designed to be in contact with, or close to, trains. Such equipment includes conductor rails, APC and AWS magnets, check rails, etc.

A 'standard platform' has its edge 730mm from the gauge corner of the nearest rail, and is 915mm above rail level. However, a number of newer platforms (Heathrow Express, East London Line) have been constructed at 1100mm above rail level, ostensibly to provide level boarding to captive rolling stock. It should be noted that such level boarding cannot be correlated with reduction in trip / fall risk, but inevitably improves accessibility. Also note that level boarding does not necessarily equate to level access, and that not all current rolling stock has adequate clearance to the 'standard' platform dimensions.

A popular misconception is that Britain's station

platforms comply with this lower sector structure gauge. Until such time as the entire British platform stock has been re-constructed, what exists is a combination of compliant platforms, those that comply with the original specification of the company that constructed them and those which simply don't comply for other reasons (see Electrification). Further, given regional and route heritage, modern rolling stock designated to specific routes provides an optimum balance between clearance whilst passing and stepping whilst stationary for those routes alone – they may be completely different to vehicles on other routes.

As noted, the relationship between platforms and vehicles is one of balance between providing clearance for passing trains (passenger and freight) and convenient and safe stepping for passengers. As with any other type of gauging, greater analysis leads to greater fit but less flexibility. Crucially, achieving compliance to a 'standard platform' will lead to the eventual harmonisation of platform stock with the consequent ability to properly optimise stepping distance. With increasing awareness of reduced mobility, and suggestions that the current rules (275mm horizontal, 250mm vertical, 350mm diagonal) provide too great a step, platform clearances are often major gauging challenges for passenger stock, and tend to restrict the space available for freight traffic.

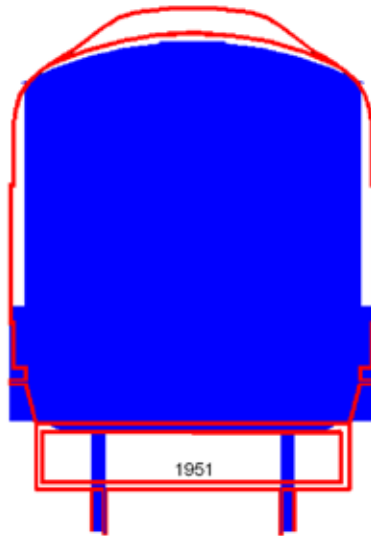

11 Passing clearances (sixfoots)

In order for trains to pass each other safely, tracks are separated by a 'sixfoot' interval, also known as the track spacing or track interval. This is generally measured horizontally and between gauge faces of the rail (although local practice should be checked). In the same way that clearances to structures need to be determined in absolute gauging, similarly it is necessary to calculate the clearances between passing trains. Thus, track positioning is a delicate balance between providing clearance to structures and / or platforms, providing safe stepping for passengers and providing adequate passing clearance.

Of particular note is the compromise that often has to be applied when running mixed passenger/freight

traffic – containers (being rectangular) require tracks to be placed further from arched bridges (a dominant form of British infrastructure) than passenger trains which are wider and fatter. Thus, passenger train capability may be compromised by the presence of freight traffic and vice-versa. Engineers strive to provide a balance, but some types of traffic may not be able to run whilst routes are available to other types. It is for this reason that heritage rolling stock should not inherit lifelong 'grandfather rights'.

12 Electrification

Gauging, as referenced so far, has related to the physical clearance between trains and the infrastructure. Electrification clearances are another matter, particularly at 25kV. Electrification in Britain is in two forms – 25kV AC overhead line electrification (OLE) or overhead contact line (OCL) in 'Eurospeak' and DC third rail (660V or 750V). Each provides its own challenges.

Third rail systems are prevalent in London and the South East, although this is by no means exclusive. Additionally some routes use a fourth rail – a central current return rail. Both of these rails require both contact with shoe gear and a physical clearance to rolling stock in a part of the vehicle that is usually fairly congested.

OLE systems require physical and electrical clearance for the passage of train pantographs (which may be the closest live part to the infrastructure) and also between electrification components, the rolling stock and the infrastructure.

Because of minimum overhead contact line heights (above rail level), a number of routes that have been electrified (notably those in East Anglia) achieved this through programs of track lowering. On these routes, the outcome also included making the platforms high, causing a number of different clearance problems not apparent at the time.

Pantograph gauging

RSSB Research projects T689 and T942 sought to characterise the sway of pantographs as part of the review of the vehicle gauging standard GM/RT2149. This research was initially aimed at relating pantograph sway to applied vehicle forces and thus provides a set of requirements consistent with other vehicle ride characteristics, such as derailment.

A further benefit of the work has enabled the space required to accommodate pantograph sway in electrification upgrades to be more accurately defined than has previously been possible. Pantograph gauging has been likened to the physical, static gauging process – a fixed allowance for sway and uplift is defined, tolerances and clearances applied and a gauge is developed applicable to generalised track criteria. As with static gauging, where cant deficiency or excess are small, the amount of space required by the method is excessive. Thus, by relating pantograph sway to the applied cant, the calculated swept envelope is reduced and less civil engineering is required to allow safe passage of a pantograph.

A further development is the calculation of wind loading on trains and thus on pantograph sway. As described earlier, the calculation of an equivalent cant deficiency resulting from wind loading may be used to calculate pantograph sway on exposed routes.

At the time of writing, GM/RT2149 is under review with the intention of incorporating dynamic pantograph sway limits developed from the research. These same limits may be applied to calculate the sway of a pantograph in assessing physical infrastructure.

13 Steam locomotives and heritage rolling stock

The 21st century railway is very different from the steam age, although there is a belief that if a steam locomotive was designed to run on the Great Western, then it should still be able to operate on that route today. In the meantime, our standards for safe operation have improved, our network is required to be capable of carrying high speed passenger and containerised freight on the same tracks, and we have re-aligned tracks to achieve better alignments and capacity. The stock of masonry arch bridges (fortunately still performing long beyond their anticipated life) means that in order to carry tall rectangular boxes, tracks must be aligned towards the centres of these arches. Conflicting requirements of wide-bodied trains requires that tracks should be as far apart as possible (subject to not conflicting with platforms).

Just because a steam locomotive used to run on a route for many years, you cannot rely on these 'grandfather rights' to do so on the same route without any further checks today – you need to do a compatibility assessment to GE/RT8270 Issue 2 - just like any other rolling stock route introduction.

Steam locomotives are presently cleared as 'out-of-gauge' loads, using a process within Network Rail known as RT3973EXL, to give limited location and duration permission to operate.

14 Double-deck trains

European-style double-decked trains are well liked, and suggestions that they could be used in Britain are not infrequent.

Aside from the overall size of European rolling stock in relation to our own bridges and tunnels, and the limits placed upon train height (further constrained by the requirements for overhead line electrification), perhaps the biggest obstacle to the introduction of Double-deck rolling stock into Britain is the restriction imposed by our platforms (which are designed around passenger accessibility). Double Deck rolling stock generally requires lower level seating to be placed in the area traditionally used for underbody equipment. With only 2895mm between standard platform faces, and allowing for vehicle wall thickness, vehicle movement, track movement and clearances, there is little space left for seating.

It is also interesting to consider the anticipated purpose of Double-decked trains. Route capacity is a factor of train capacity and station dwell time. Whilst Double-deck trains can carry more passengers per unit of floor area, their dwell times at stations are longer than well designed conventional rolling stock. Thus, route capacity is only increased if the latter issue is more than compensated by the former. On British (suburban) routes where additional route capacity is required, it is unlikely that Double-deck trains (because of stopping patterns) would provide better capacity than well designed 23m, wide-bodied rolling stock.

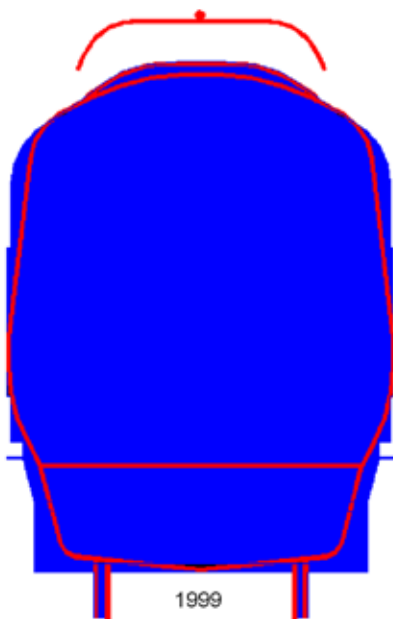

15 Gauging surveying

Whilst this guide has been aimed primarily at those intending to operate rolling stock, it may also guide others operating in the field of gauging where knowledge may not obviously be required. Surveying is a well-developed discipline, but one where the foibles of subsequent analysis frequently trap the unwary - resulting in much wasted effort and project delays. Accordingly, this section has been included to indicate some aspects of gauging survey that potential surveyors should consider.

Network Rail is able to provide detailed guidance on their requirements for network survey.

Various tools are available for railway structure surveying; the following indicate some commonly used, and others contemplated.

Discrete profile measuring

Several types of system are available for measuring discrete points on structures. As such, they are quite time consuming if a structure must be measured in detail, but have a place where bulk measurement (using on-train systems) is not cost-effective. By definition, judgment has to be used to understand which points need to be measured – a process requiring some skill and experience as this guide may have indicated. Further, site details, cant and curvature are usually required, needing specialist equipment for this purpose. Examples of discrete systems are:

3D Scanners

Systems for 3D scanning have become readily available, and have their place. Point clouds contain large amounts of data and can also contain noise which may lead to bogus tight clearance calculations. It is therefore necessary to use software which converts this data into usable profiles. Such software must be validated, and approval may be required by Network Rail before accepting its use in gauging surveying. Additionally, all equipment must be calibrated and suitable for the purpose intended. When used, for example, for platform gauging, it will be necessary to use a methodology which adequately captures a virtual platform 'edge' coordinate¹⁴. Such equipment also needs to be certified and calibrated to work with the measuring system.

Pole and Tape

This heritage method uses measurements from each rail to a point on the structure which is triangulated into an x-y point position. It is relatively inaccurate and unsuitable on electrified routes. This is no longer considered accurate or sufficiently detailed for today's use.

Bridge Gauge

Bridge gauges consist of a frame from which specific measurements are taken. This is no longer considered accurate or sufficiently detailed for today's use.

¹⁴ Curved edge platform nosing requires a maximum vertical and horizontal coordinate to be calculated.

Laser Profiling Frames

These devices consist of a rangefinder type system mounted to a track reference frame which can be directed at individual structure points and the range, angle and track cant recorded. Such frames are considered suitable for measurement of discrete structure points.

Platform Gauge

These are used to measure platform edge details. Modern, braced frames are considered suitable. It should be noted that a platform edge is considered to be at the intersection of the top surface and the minimum width. This point is virtual in the case of 'bull nosed' (ie, rounded) platform coping stones.

Continuous Measurement

Network Rail operates two types of continuous system, both based upon optical triangulation and integration. These systems measure continuously, and record the 'tightest' profiles at fixed intervals. The two systems in use are road-rail (Laser Gauging Vehicle) and train borne (Structure Gauging Train). These vehicles are deployed on a structured program to update the National Gauging Database on a regular basis.

Scanner type systems have been tested, but have not, to date, been incorporated into production measuring trains. Their use would require similar assurance to their static counterparts.

16 Risk

Gauging is about risk management. Clearances are provided to mitigate risk. Reducing clearance below minimum levels will increase risk. Heritage methods of gauging mitigated risk by providing very large margins of safety. Modern methods seek to provide an accurate numerical measure of risk and to balance that level of risk; in particular by understanding system behaviour, by understanding what tolerances there are and how to apply them and by accurate calculation, it is possible to reduce the minimum level of clearance required by decreasing allowances for uncertainty included in early calculations.

It is about this understanding of risk that decisions are made about whether trains may run or not. Anecdotally, it has been said that trains have been refused permission to run when they have been physically demonstrated to be clear – for example oversized loads that should not have been allowed but which travelled without (known) incident. This is because, as clearance for unknowns is reduced, allowance must be made for events which may cause the clearance to be further eroded. Test running a new train, partially loaded (even if fitted with polystyrene blocks) is far removed from the extremes of operating environment that it will experience during its lifetime. A crush loaded train with significant wear to its suspension system will sway more than when new and lightly loaded. Further, since the rocking motion is (essentially) random, then the clearance to lineside objects will also be largely random – one day it may be well clear, another day frighteningly close. Computer simulations are designed to simulate these

lifetime conditions.

It is also the case with track alignment. Whilst it may be physically possible to run a train, it may be that the track positioning is sufficiently confined to prevent effective maintenance – track geometry may only be corrected by lifting the track¹⁵. Thus, whilst it may be possible to provide clearance at a given location, maintaining the clearance may have serious cost implications, affecting viability of such traffic provision. Network Rail's engineers apply clearance risk regimes of 'normal', 'reduced' or 'special reduced', depending upon the level of risk calculated from an understanding of track fixity and other maintenance related factors to ensure that ongoing operational costs are minimised.

As our understanding of gauging risk grows, so we may be able to fit more through our inherited infrastructure. As we have done for years...

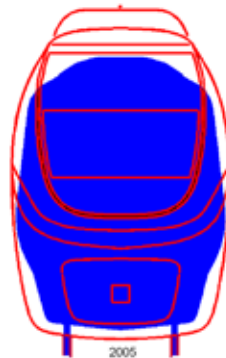

¹⁵ Track maintenance is effected by re-packing ballast around sleepers following correction of position. This may only be done by lifting the sleeper, re-packing the ballast and lowering – resulting in an overall lift, usually of around 25mm. This lift then 'settles out' as the maintenance cycle progresses, until correction is again required.

Appendix 1 – The route to gauging compatibility demonstration

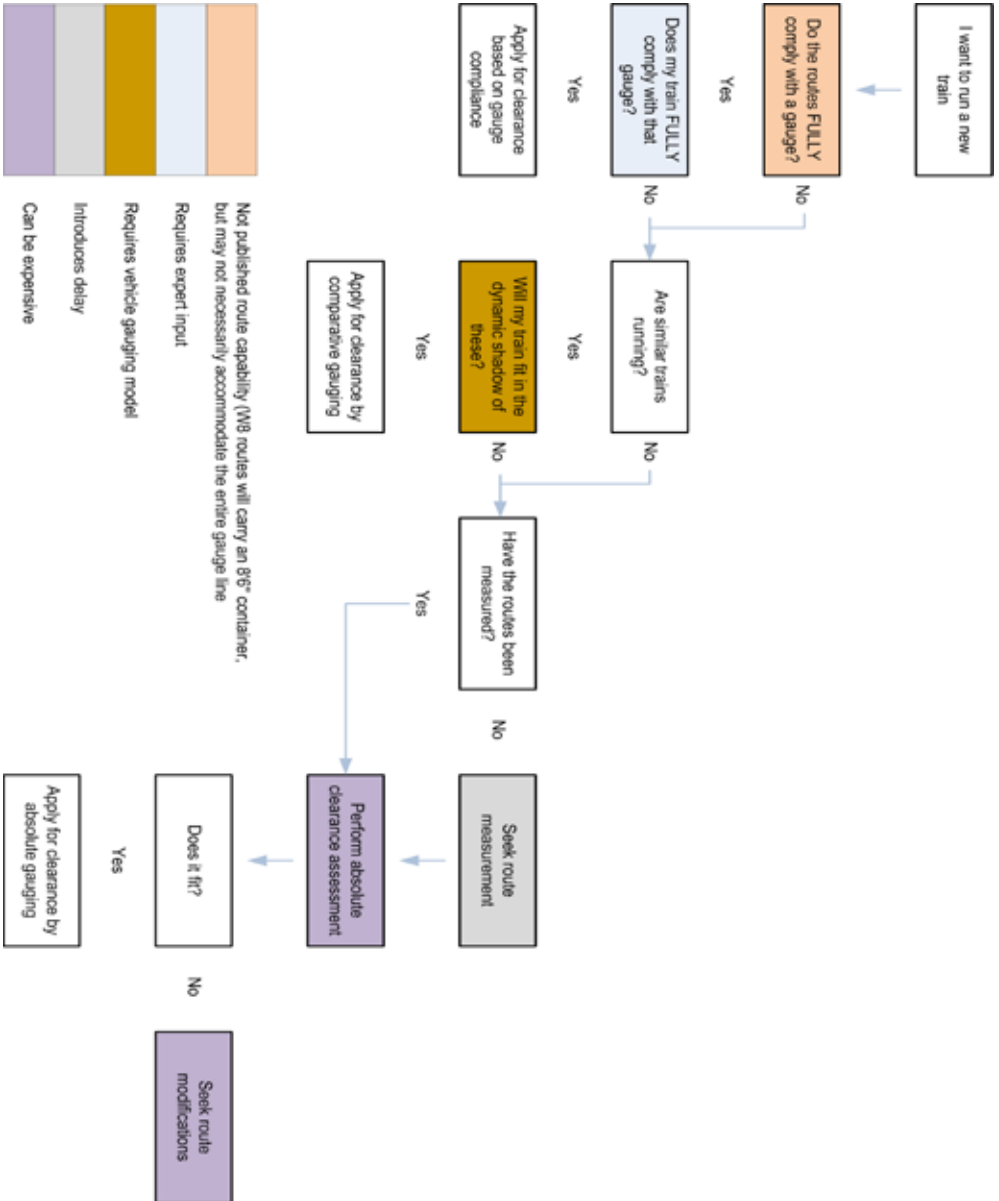

Appendix 2 – Further information

Further Reading

GE/RT8073 (Issue 2¹⁶) defines standard British railway gauges and the rules for applying them.

GM/RT2149 (Issue 3) defines the requirements for rolling stock, including that related to gauging.

GC/RT5212 (Issue 1) defines gauging requirements for the infrastructure.

GE/RT8270 (issue 2) defines the requirements for demonstrating compatibility between trains and the infrastructure.

GE/GN8573 (Issue 3) provides guidance in the use of the above gauging standards and additional information

The RSSB 'Archive of Gauging Documents', available on CD, provides a number of historic documents from which the history of gauging techniques may be understood and the origin of gauge dimensions charted.

UIC Leaflet 505 describes the European methodology (although a more concise descriptive document is contained on the CD above)

EN15273:2009 (Parts 1, 2 and 3) is the emerging Euronorm for gauging in Europe.

¹⁶ Document issue numbers are correct at the time of publication of this document.

Further Assistance

It cannot be overstated that early involvement with engineers experienced in gauging is worthwhile. This guide has outlined a number of principles in the hope that the unwary may not succumb to the pitfalls encountered by others before them. However, gauging has often been considered in the later stages of rolling stock introduction programs which has invariably led to embarrassing delays in service introduction and attracted criticism to the rail industry, often addressed at those who do not deserve it. A model example of where gauging was considered at the outset of a project was that of class 390, Pendolino. In this case, gauging of the tilting trains was considered an integral part of train development and led to the train being brought into service with all gauge proving having been done on computer.

Network Rail's gauging engineers are a very good point of initial contact for considering the development of any new rolling stock. Their wealth of knowledge about the network is likely to point to where there may be problems.

Contact: Network Rail HQ gauging engineer

Contact RSSB's technical enquiry desk to address issues related to Railway Group Standards and Guidance, which will be forwarded to appropriate technical experts.

Members of the Vehicle/Structures Systems Interface Committee may also be able to direct questions to appropriate technical experts.

Contact: RSSB Enquiry Desk (020 3142 5400 or email enquirydesk@rssb.co.uk)

Guidance on how to address European and UK regulatory requirements for vehicle compatibility assessment, including gauging may be sought from ATOC Engineering, or by referring to the document ATOC Guide to Vehicle Change (available on request from ATOC at enquiry@atoc.org)

Whilst analysis can be expensive, it is unlikely to be as costly as a mistake, and that initial discussions with experts are unlikely to cost anything.

The RSSB Archive of Gauging Documents, available on CD, provides a historic catalogue of references used to develop the gauging process. Whilst this has no value in actual assessment, it provides some background information as to why things are as they are, and where certain numbers have come from.

This guide was produced by David Johnson under RSSB research contract T926. Any suggestions for future improvement of (or corrections to) this guide would be welcomed.

Contact: davidm.johnson@btinternet.com

Appendix 3 – Previous cover photographs

For those interested in the photographs used on the cover of issue 1 (December 2010) of this guide, they are reproduced here:

An incident at a Chicago marshalling yard resulting from an unsuitable combination of wagon and container is more common in Britain than desirable. Several station canopies have been remodeled by out-of-gauge loads. Significantly, gauge constraints are not confined to 'small' networks – the desire to get best commercial return means that our W12 is the USA's 'double stack'.



The 'Toblerone' train is a former Kinki Nippon Railway – 'Kintetsu' – KuMo270 series EMU. It was built in 1977 by Kinki Sharyo for the 2'6" / 762mm gauge Hokusei line from Nishi-Kuwana to Ageki, near Nagoya. This line, set to close, was taken over by the Sangi Railway. The following photographs shows the train after and before modification.



The Hastings line required specific rolling stock, on account of restrictive tunnels. Until single tracked, not even 'standard' British Rail C1 rolling stock would fit. The photograph shows a straight-sided 'Hastings' DMU.



Britain experimented with double-decked trains, in the form of the Oliver Bulleid designed 4DD stock on the Southern Region of British Railways, designed to fit within the C1 gauge between 1949 and 1971. These vehicles were described as claustrophobic and poorly ventilated, even in their time. Each 4-car set carried 552 seated passengers and 150 standing passengers.

Photograph copyright Michael Taylor



Image of Rainhill Skew Bridge, page 6, courtesy of www.historic-uk.com - The History and Heritage Accommodation Guide.

RSSB

Block 2 Angel Square, 1 Torrens Street, London EC1V 1NY.
www.rssb.co.uk

Tel: 020 3142 5300

Fax: 020 3142 5663

Email: enquirydesk@rssb.co.uk

