



Vessel name	Built	IMO no.	Flag	Vessel name	Built	IMO no.	Flag
Norderoog	2004	9256315	Gibraltar	Hooge	2006	9301122	Gibraltar
Suederoog	2005	9256327	Gibraltar	Petkum	2008	9386988	Antigua & Barbuda
Langeness	2006	9301134	Antigua & Barbuda	Wybelsum	2008	9386976	Gibraltar

MAIN DATA

Vessel type	Singledecker Containervessel
Classification	GL + 100 A5 E3 + SOLAS II + MC E3 AUT equipped for the carriage of containers, equipped for the carriage of dangerous goods
GT/NT	15,633 / 6,717
Deadweight (summer)	16,921 mt
Max. draft (summer)	9.90 m
Length o.a.	161.35 m
Length between pp.	151.35 m
Breadth moulded	25.00 m
Depth to main deck	13.90 m
Height above keel	47.10 m
Max. Speed	19.5 knots
Fuel consumption	45.0 mt RMG 380 fuel per day at sea 2.0 mt RMG 380 per day in port without gear 3.0 mt MGO DMA per day in port with gear

HOLDS/HATCHES/CRANES

Floor space under deck	1,662 sqm / 17,889 sqft		
Floor space on deck	1,873 sqm / 20,160 sqft		
Cranes	2 cranes situated midships 45 mt capacity each Wybelsum is gearless		
Container intake	1368 TEU nominal 870 TEU at 14 mt homogeneously loaded 258 reefer plugs		
Container stackweights		20'	40'
	Hatch covers 1-2	60 mt	104 mt
	Hatch covers 3-8	60 mt	120 mt
	Tanktop	120 mt	150 mt

SPECIAL EQUIPMENT/FEATURES

Fitted for trading Australia.
Fitted for carriage of dangerous goods of all IMO classes.

Norderoog	Hooge
Suederoog	Petkum
Langeness	Wybelsum (gearless)

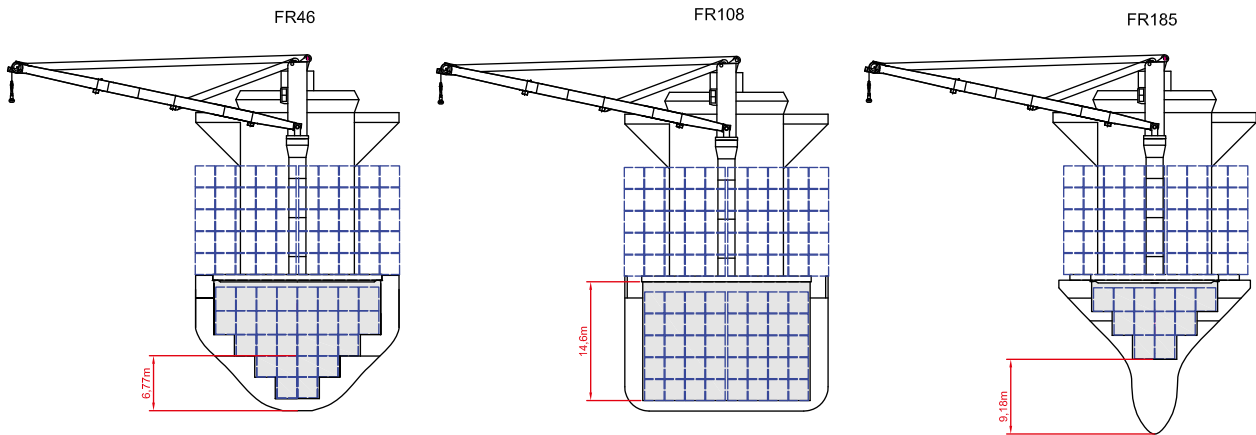
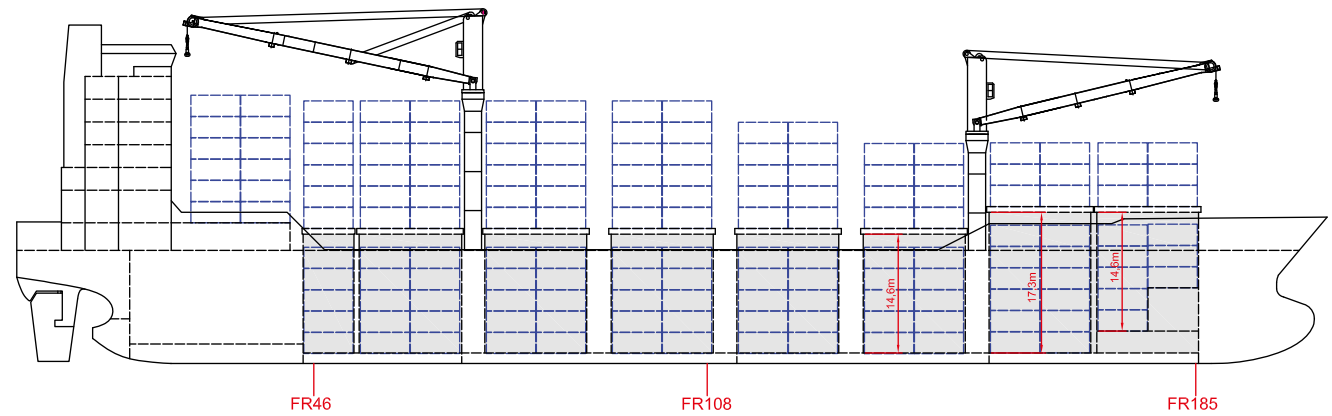
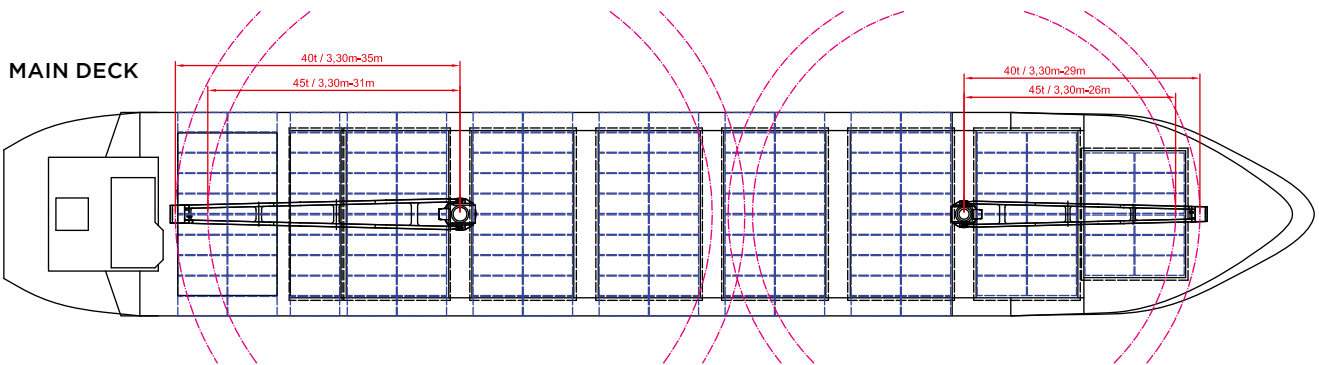
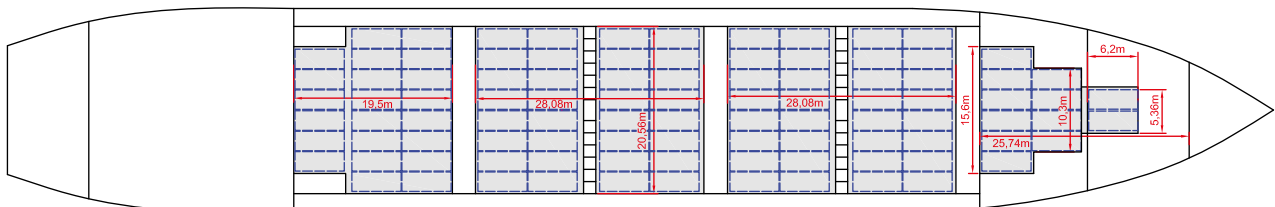
SIDE VIEW

MAIN DECK

HOLD 6.77m above BL

HOLDS & DOUBLE BOTTOM
