British Railways Board

Mechanical & Electrical Engineering Department

VEHICLE DIAGRAM BOOK NO 210

FOR

Electric Multiple Units

(Including A.P.T.)

© COPYRIGHT NOTICE

This PDF file has been created from the original book with permission of BRB Residuary Ltd who, retain copyright in the original document.

The original book was provided courtesy of Eddie Knorr.

This PDF version by David Faulkner, 2012.

Individuals may: use, retain and print out this PDF version for their private information or for that of their non-commercial enthusiast society or railway club.

This document and any copies produced from it in any form may not be sold or lent for any payment in any form other than to cover copying or transmission costs. No reproduction permitted in any other form or circumstance without prior permission from the original copyright holder

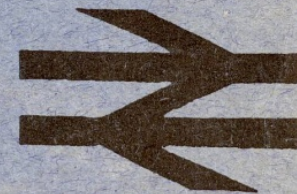

Contained in this book:

Design Code	Class	Vehicle Type	ex Diag	Issue	Date
EA201	507	DMS	864	3	Aug 82
EA204	313	DMS	485	3	Aug 82
EA206	314	DMS	487	3	Aug 82
EA207	315	DMS	488 & 489	5	Apr 88
EA208	508	DMS		2	May 81
EA260	432	DMS	890A	3	Aug 85
EA261	411/3	DMS	882	3	Apr 86
EA262	411/3	DMS	882	3	Mar 86
EA263	412 411/4	DMS		3	Nov 84
EA264	412 411/5	DMS	884	5	Nov 84
EB201	501	DMBS	403	2	May 81
EB202	502	DMBS	LMS 345	2	May 81
EB203	503	DMBS	LMS 344A	1	Sep 80
EB204	504	DMBS	407	1	Sep 80
EB205	506	DMBS	LNE 363	2	May 81
EB207	309/1	DMBS		2	Mar 87
EB260	487	DMBS	SR 842	1	Sep 80
EB261	485 486	DMBS	SR 848	1	Sep 80
EB262	485	DMBS	SR 848	2	May 81
EB265	405	DMBS	SR 2126	3	Mar 86
EB266	415/0	DMBS	SR 2129	6	Mar 86
EB267	415/0	DMBS	SR 2130	6	Sep 88
	413/2				
	414/2				
EB269	415/0 415/3 416/2	DMBS	400	5	Nov 84
	414/3				
EB270	413/3	DMBS	400	5	Nov 84
	414/3				
EB271	415/3	DMBS	414	8	Mar 86
EB272	415/3	DMBS	414	7	Mar 86
EB273	410/1	DMBS	402	3	Jan 84
	410/2				
EB274	411/2	DMBS	402	3	Mar 86
EB277	415/4	DMBS	SR 2129	5	Mar 86

Design Code	Class	Vehicle Type	ex Diag	Issue	Date
EB278	415/4 416/3	DMBS		4	Jan 84
EB279	416/2	DMBS		2	Nov 84
EB280	416/4	DMBS		4	Oct 88
EB281	416/4	DMBS		1	Oct 88
EC202	317	MS	483	4	May 84
EC203	455	MS		3	Mar 88
EC204	307	MS		2	Aug 82
EC205	307/2	MS		3	Oct 86
EC206	455/4	MS		2	Mar 88
EC207	318	MS		1	Oct 86
EC209	319	MS		1	Jan 88
EC210	321	PMS		1	Oct 88
ED201	303	MBS	416	1	Sep 80
	304/2				
ED203	304/3	MBS	409	1	Sep 80
ED204	305/1	MBS	413	6	Mar 87
ED205	302	MBS	405	2	Aug 83
ED210	310	MBS	424	1	Sep 80
ED211	311	MBS	385	2	May 81
ED212	312/0	MBS	490	3	Mar 87
ED213	312/1	MBS	491	3	Mar 87
ED214	312/2	MBS	492	3	Mar 87
ED215	304/1	MBS	408	4	Apr 86
	302				
ED216	305/2 308/1	MBS		2	Aug 83
	302				
ED217	302	MBS	405	1	Aug 83
	309/2				
ED218	309/3	MBS		2	Mar 87
	310/0				
ED219	310/1	MBS		1	Aug 88
	422/1				
	422/2				
ED260	421/1 421/2	MBS	423	4	Mar 86
ED261	423	MBS	880	2	May 81
ED262	423/1	MBS	840	1	Sep 80
ED263	423	MBS	881	1	Sep 80
ED265	442	MBSL		1	Jul 88

Design Code	Class	Vehicle Type	ex Diag	Issue	Date
EE160	422	DTF		1	Jul 88
EE202	503	DTS	LMS 392A	2	May 81
EE204	506	DTS	LNE 365	2	May 81
EE205	302	DTS	433	2	Mar 87
EE206	303	DTS	439	1	Sep 80
EE207	502	DTS	LMS 393	2	May 81
EE209	305/1	DTS	436	6	Aug 87
EE210	305/2	DTS	437	1	Sep 80
EE214	311	DTS	375	2	May 81
EE215	504	DTS	443	2	May 81
EE216	317/1	DTS(A)	463	4	Nov 88
EE218	455	DTS		2	Dec 82
EE219	302	DTS		3	Mar 87
EE220	305/2 308/1	DTS		1	Apr 83
EE221	413/2	DTS		1	Apr 83
EE222	413/3	DTS		1	Apr 83
EE223	302	DTS		1	Aug 83
EE224	317/2	DTS(A)		1	May 85
EE225	317/2	DTS(B)		1	May 85
EE226	455/4	DTS		1	Aug 85
EE227	318	DTS(A)		1	Oct 86
EE228	318	DTS(B)		1	Oct 86
EE229	309/2 309/3	DTS		1	Oct 86
EE232	317/1	DTS(B)	463	1	Jan 86
EE233	319	DTS(A)		1	Jan 88
EE234	319	DTS(B)		1	Jan 88
EE235	317/1	DTS(B)	463	1	Apr 86
EE236	321	DTS		1	Oct 88
EE237	310/1	DTS		1	Aug 88
EE260	485 486	DTS	SR 850	1	Sep 80
EE264	416/2	DTS	420	3	Nov 84
EE266	437	DTS	900A	4	Aug 85
EE269	416/3	DTS		2	Jan 84
EE271	416/4	DTS		2	Oct 88
EE273	442	DTS		1	Jul 88
EE274	416/4	DTS		1	Oct 88

Design Code	Class	Vehicle Type	ex Diag	Issue	Date
	312/0				
EE305	312/1	DTC	461	4	Mar 87
	312/2				
EE306	310	DTC	454	2	Dec 85
EE307	307	DTC		2	Mar 87
EE308	321	DTC		1	Oct 88
EE361	414/2	DTC	441	4	Aug 85
	413/2				
EE362	414/3	DTC	441	4	Aug 85
	413/3				
	422/1				
EE363	422/2	DTC	452	4	Nov 84
	421/1				
	421/2				
	422/1				
EE364	422/2	DTC	453	3	Jan 84
	421/1				
	421/2				
EE365	423	DTC	458	3	Mar 86
EE366	423/1	DTC	841	1	Sep 80
EE367	423	DTC	459	4	Mar 86
EE368	423	DTC	459	1	Jun 86
EF201	302	BDS	432	3	Mar 87
EF202	303	BDS	439	1	Sep 80
EF203	304/1	BDS	434	1	Sep 80
	304/2				
EF204	304/3	BDS	435	2	May 81
EF205	305/1	BDS	436	5	Mar 87
EF206	305/2	BDS	438	1	Sep 80
EF208	308/2	BDS	444	2	Aug 87
EF210	310	BDS	454	2	Dec 85
	310/0				
EF211	310/1	BDS	428	3	Aug 88
EF212	311	BDS	375	1	Sep 80
	312/0				
EF213	312/1	BDS	465	3	Mar 87
	312/2				
EF214	310	BDS	482	3	Dec 85
EF216	309/1	BDS		1	Oct 86

Design Code	Class	Vehicle Type	ex Diag	Issue	Date
EF302	305/2 308/1	BDTC		1	Apr 83
EF303	302	BDTC		2	Mar 87
EF304	305/2 308/1	BDTC		1	Aug 83
EF305	309/2 309/3	BDTC		1	Oct 86
EG201	501	DTBS	410	1	Sep 80
EG202	304/1	DTBS	411	1	Sep 80
EG203	304/2 304/3	DTBS	412	2	Dec 81
EH160	437	TF	930A	4	Nov 84
EH202	502	TS	LMS 379	2	May 81
EH204	506	TS	LNE 366	2	May 81
EH205	507	TS	865	3	Aug 82
EH208	310	TS	473	1	Sep 80
EH209	312/0 312/1 312/2	TS	476	3	Mar 87
EH210	313	TS	477	4	Mar 87
EH211	314	TS	479	3	Aug 82
EH213	501	TS	478	2	May 81
EH214	503	TS	LMS 368A	2	Aug 81
EH216	315	TS	468	4	Aug 82
EH217	315	TS	467	5	Nov 87
EH217	315	TS	467	4	Mar 87
EH218	508	TS		3	Aug 82
EH219	455	TS		4	Apr 83
EH221	455	TS		2	Dec 82
EH222	307	TS		5	Nov 87
EH223	302 305/2 308/1	TS		4	Nov 87
EH224	455/4	TS		1	Aug 85
EH225	304/1	TS	456	1	Mar 85
EH226	304/2 304/3	TS	457	1	Mar 85
EH227	309/1	TS		1	Oct 86
EH228	309/2	TS		1	Oct 86
EH229	309/3	TS		1	Oct 86

Design Code	Class	Vehicle Type	ex Diag	Issue	Date
EH232	310/0 310/1	TS		1	Aug 88
EH234	319	TS		1	Jan 88
EH235	321	TS		1	Oct 88
EH260	487	TS	SR 846	1	Sep 80
EH261	485 486	TS	SR 849	1	Sep 80
EH262	405	TS	SR 2314	1	Sep 80
EH263	405	TS	SR 2013	2	Mar 86
EH265	405	TS	SR 2015	1	Sep 80
EH266	405	TS	SR 2018	1	Sep 80
EH267	415/0	TS	SR 2314	3	Nov 84
EH268	415/0 415/3	TS	SR 2013	3	Nov 84
EH270	415/0 415/3	TS	SR 2018	4	Jan 84
EH271	415/3	TS	480	4	Aug 85
EH273	411/2	TS	460	1	Sep 80
EH274	411/2	TS	450	1	Sep 80
EH275	421/1 421/2	TS	472	2	Nov 84
EH276	423	TS	474	2	May 81
EH277	411/3	TS	901	1	Sep 80
EH278	423/1	TS	842	1	Sep 80
EH279	415/4	TS		3	Jan 84
EH280	415/4	TS		3	Jan 84
EH281	415/4	TS		7	Mar 86
EH282	411/5	TS	903	3	Apr 83
EH283	423	TS	475	2	May 81
EH284	411/5	TS		3	Nov 84
EH285	488/3	TS		1	Aug 83
EH288	442	TS(A)		1	Jul 88
EH289	442	TS(B)		1	Jul 88
EH290	488/3	TS		1	Apr 88
EH302	302	TC	455	4	Mar 87
EH303	304/1	TC	456	1	Sep 80
EH304	304/2 304/3	TC	457	1	Sep 80
EH307	317/1	TC	466	7	Nov 88
EH308	317/2	TOC		3	Nov 88
EH309	309/1	TC		2	Mar 87

Design Code	Class	Vehicle Type	ex Diag	Issue	Date
EH360	410/1	TC	450	3	Jan 84
EH361	410/2	TC	450	2	May 81
	411/2				
EI201	313	BDMS	486	2	Aug 82
EI202	507	BDMS	863	3	Aug 82
EI203	508	BDMS		3	Aug 82
EJ160	432	TBF	910A	3	Nov 84
EJ260	437	TBS	920A	4	Nov 84
EJ360	921	TBC	921	2	Nov 84
	412				
EJ361	411/5	TBC	922	6	Nov 84
	422/1				
EN260	422/2	TRBS	427	3	Jan 84
	412				
EN261	412	TRB		2	Jan 84
EN460	410/1	TRB	425	2	May 81
EN461	410/2	TRB	425	1	Sep 80
EN462	432	TRB	940	2	Jan 84
EN463	432	TRB	941	3	Jan 84
EO202	307	BDBS		2	Mar 87
EP101	488/2	TFH		2	Jun 86
	488/2				
EP201	488/3	TSH		1	Aug 83
	488/2				
EP202	488/3	TSH		1	Apr 88
	308/2				
EW501	308/2	DTLV		1	May 84
EX560	419	DMLV	498	1	Sep 80
EX561	489	DMLV		1	Aug 83
EY501	308/2	MLV	497	1	Sep 80
LC501	370	M	883	2	Aug 81
LE201	370	DTS	902	2	Aug 81
LH101	370	TF	931	2	Aug 81
LH201	370	TS	950	2	Aug 81
LH401	370	TU	960	2	Aug 81
LJ101	370	TBF	911	2	Aug 81
LK201	370	TRSB	942	2	Aug 81

PREFACE

A complete list of Vehicle Diagram Books is shown below, together with new or revised book reference numbers & the colours of the respective book covers. The existing Diagram books covering Locomotives and Rail Crane vehicles which were previously shown with MT/reference numbers, have now received new covers in accordance with this revised numbering system.

REVISED VEHICLE DIAGRAM BOOK NUMBERS

Vehicle Type	Diagram Book No	Colour of Cover	Vehicle Type	Diagram Book No	Colour of Cover
<u>Locomotives:- Diagram Book Series 100</u>			<u>Freight Vehicles:- Diagram Book Series 300</u>		
Diesel Electric Main Line Locos	100 (Previously No MT/25)	Red	Privately Owned Freight Vehicles	300	White
Electric Main Line Locos	110 (Previously No MT/26)	Green	Privately Owned International Ferry Vehicle	310	White
Diesel Shunting Locos	120 (Previously No MT/27)	Yellow	BR Revenue Freight Vehicle	320	Buff
<u>Coaching & Multiple Unit Stock:- Diagram Book Series 200</u>			BR International Ferry Vehicles	330	Buff
Loco Hauled Coaches	200	Orange	Foreign Administration Freight Vehicles	340	White
Electric Multiple Units	210	Blue	BR Service Department Vehicles	350	Buff
Diesel Multiple Units (Railcar)	220	Pink	<u>ON Track Plant:- Diagram Book Series 400</u>		
Diesel Electric Multiple Units (HST)	230	Pink	Rail Cranes & Tracklaying Vehicles	400	Red
				(Previously No MT/212)	

JULY 1982

Issued by:-

Director of Mechanical & Electrical Engineering
Railway Technical Centre
DERBY

VEHICLE DIAGRAM BOOK NO 210

FOR

Electric Multiple Units

(Including A.P.T.)

SUMMARY OF CONTENTS

NOTE:- The contents of this book are arranged in alphabetical order, according to vehicle DESIGN CODE

EA	Driving Motor Second	LC	Motor-APT
EB	Driving Motor Brake Second	LE	Driving Trailer Second-APT
EC	Motor Second	LH	Trailer First-APT
ED	Motor Brake Second	LH	Trailer Second-APT
EE	Driving Trailer Second	LH	Trailer Unclassed-APT
EE	Driving Trailer Composite	LJ	Trailer Brake First-APT
EF	Battery Driving Trailer Second	LK	Trailer Restaurant Second with Buffet-APT
EF	Battery Driving Trailer Composite		
EG	Driving Trailer Brake Second		
EH	Trailer First		
EH	Trailer Second		
EH	Trailer Composite		
EI	Battery Driving Motor Second		
EJ	Trailer Brake First		
EJ	Trailer Brake Second		
EJ	Trailer Brake Composite		
EM	Trailer Griddle - Unclassed		
EN	Trailer Buffet Second		
EN	Trailer Buffet - Unclassed		
EO	Battery Driving Trailer Brake Second		
EX	Driving Motor Luggage Van		
EY	Motor Luggage Van		

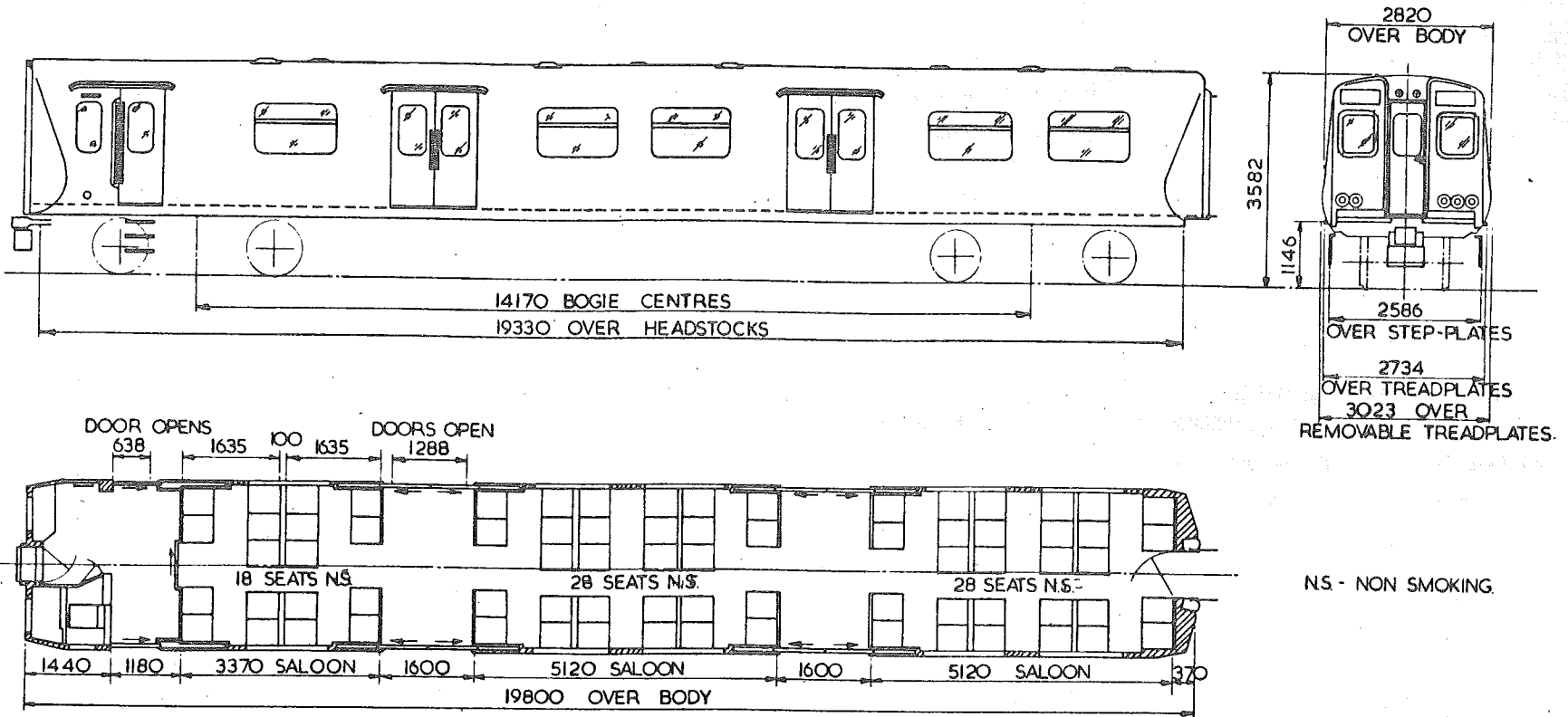

NS - NON SMOKING.

- SEATS 74
- TOILETS -
- COMPARTMENTS -
- GUARDS COMPARTMENTS - CAB WHEN TRAILING
- VENTILATION -
- CATERING EQUIPMENT -

ORIGINAL DIAGRAMS FOR REFERENCE, -
BR 864

ISSUE 3 DATE AUG 82

EA 201

BASIC TYPE

ALTERNATIVES

BRAKES
BOGIE/SUSPENSION
BODY CONSTRUCTION
COUPLINGS
TRAIN HEATING
MAX. SPEED M.P.H.
MINI RAD. CURVE CHAINS
LIGHTING
TARE WEIGHT TONNES
GANGWAYS
A/S
TRAIN COMMUNICATION
BUMPERS

ELECTRO PNEUMATIC
BX1/Pc & BX1/Pg (ONE OF EACH)
STEEL UNDERFRAME & BODY FRAMING-ALUMINIUM BODY & ROOF
AUTOMATIC TIGHTLOCK OUTER END-BAR INNER END
ELECTRIC-DUCTED WARM AIR
75
3.5
FLUORESCENT & TUNGSTEN
35.5
FLEXIBLE DIAPHRAGM/RIGID (GRP) INNER END ONLY
FITTED
DRIVER/GUARD-PUBLIC ADDRESS WITH TRANSMITTER
NOT FITTED

TRACTION DATA FOR MULTIPLE UNITS

EMU- GARSTON-LIVERPOOL-SOUTHPORT. INTRODUCED 1979
VOLTAGE 600/750 VOLTS D.C. THIRD RAIL
TRACTION MOTORS 4 X 110 HP GEC

BASIC TYPE

EA 201 OA

VARIANTS

NONE

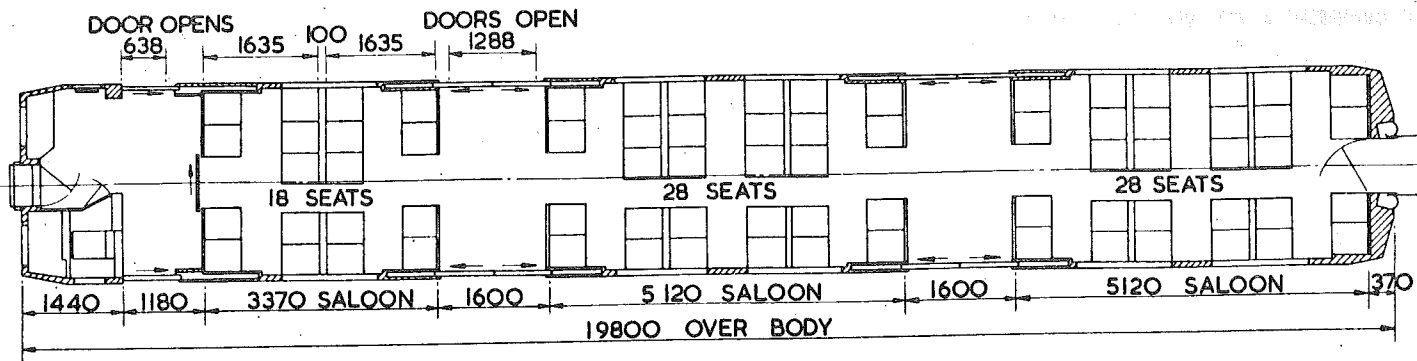
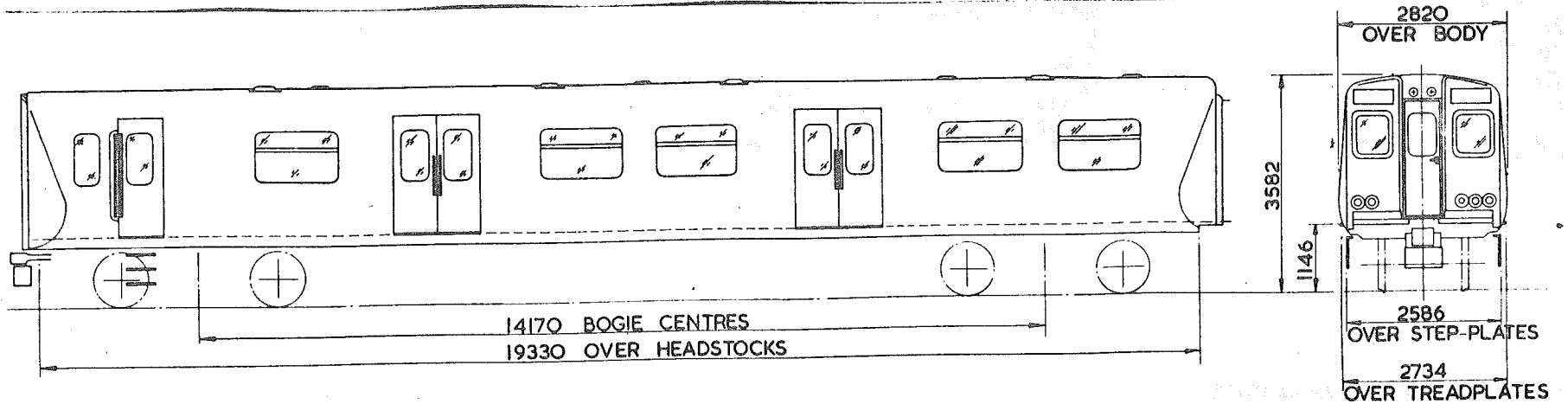

SEATS 74
 TOILETS -
 COMPARTMENTS -
 GUARDS COMPARTMENTS -
 VENTILATION -
 CATERING EQUIPMENT -

ORIGINAL DIAGRAMS FOR REFERENCE.-
 BR 465

ISSUE 3 DATE AUG '82

EA 204

BRAKES
BOGIE/SUSPENSION
BODY CONSTRUCTION
COUPLINGS
TRAIN HEATING
MAX. SPEED M.P.H.
MIN. RAD. CURVE CHAINS
LIGHTING
TARE WEIGHT TONNES
GANGWAYS
A/U.S.
TRAIN COMMUNICATION
BUFFERS

BASIC TYPE

ELECTRO PNEUMATIC
BX1/P_a & BX1/P_b (ONE OF EACH)
STEEL UNDERFRAME & BODY FRAMING-ALUMINIUM BODY & ROOF
AUTOMATIC TIGHTLOCK OUTER END-BAR INNER END
WASTE HEAT RECOVERY-DUCTED WARM AIR
75
3.5
FLUORESCENT & TUNGSTEN
36
FLEXIBLE DIAPHRAGM/RIGID (GRP) INNER END ONLY
FITTED
DRIVER/SIGNAL BOX, DRIVER/GUARD, PUBLIC ADDRESS
NOT FITTED

ALTERNATIVES

STEEL UNDERFRAME, BODY FRAMING & BODY-ALUMINIUM ROOF

TRACTION DATA FOR MULTIPLE UNITS

EMU- GREAT NORTHERN INNER SUBURBAN. INTRODUCED 1976
VOLTAGE 25 KV A.C. OVERHEAD & 750 VOLTS D.C. THIRD RAIL
TRACTION MOTORS 4 X 110 HP GEC G310AZ

BASIC TYPE

EA 204 0A

VARIANTS

08- STEEL UNDERFRAME, BODY FRAMING & BODY-ALUMINIUM ROOF.

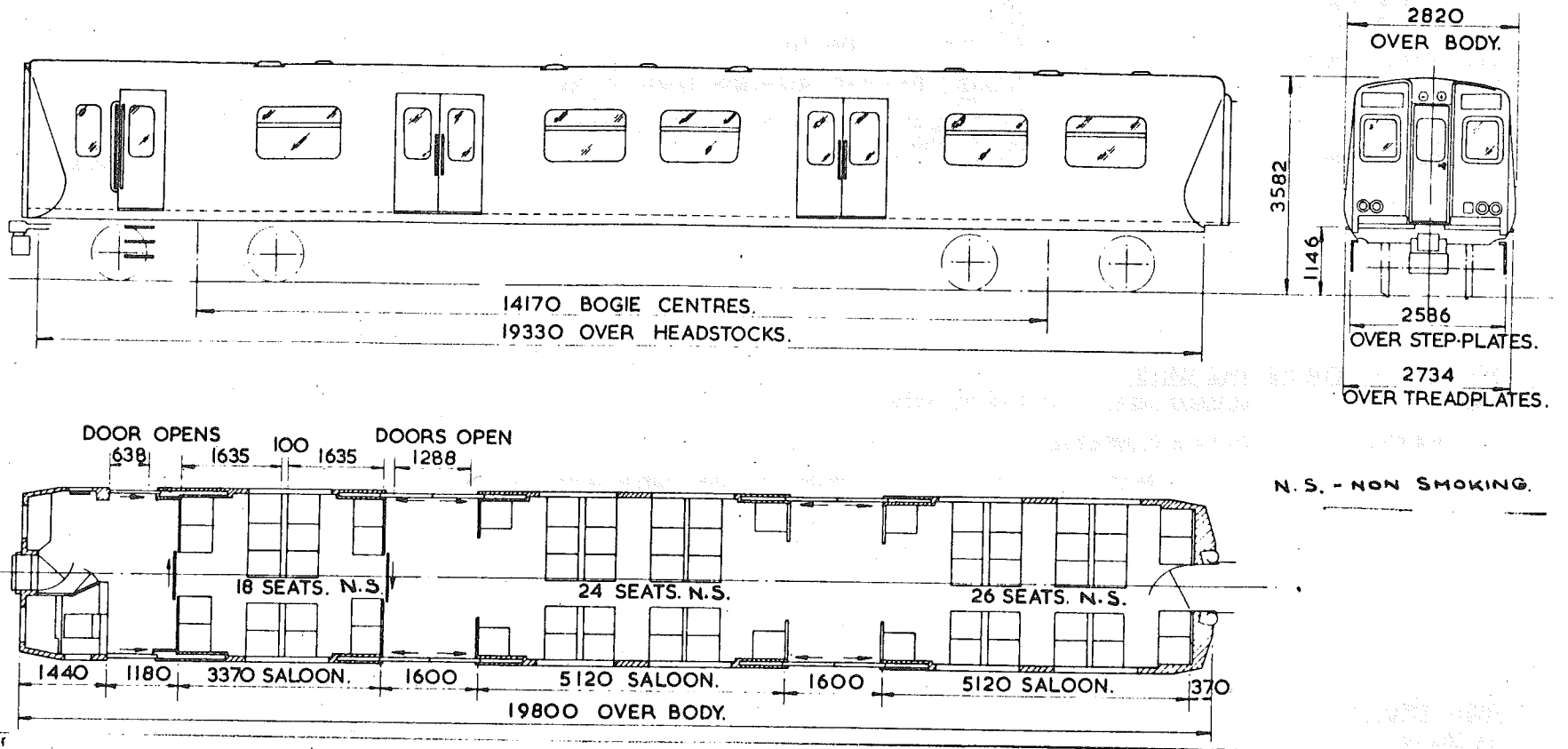

- SEATS 68
- TOILETS -
- COMPARTMENTS -
- GUARDS COMPARTMENTS -
- VENTILATION -
- CATERING EQUIPMENT -
- CAB WHEN TRAILING -

ORIGINAL DIAGRAMS FOR REFERENCE.-
BR 487

ISSUE 3 DATE AUG '82

EA 206

BASIC TYPE

BRAKES
BOGIE/SUSPENSION
BODY CONSTRUCTION
COUPLINGS
TRAIN HEATING
MAX. SPEED M.P.H.
MIN. RAD. CURVE CHAINS
LIGHTING
TARE WEIGHT TONNES
GANGWAYS
A. V. S.
TRAIN COMMUNICATION
BUFFERS
EMERGENCY EQUIPMENT

ELECTRO PNEUMATIC
BX1/Pc & BX1/Pd (ONE OF EACH)
STEEL UNDERFRAME & BODY FRAMING-ALUMINIUM BODY & ROOF
AUTOMATIC TIGHTLOCK OUTER END-BAR INNER END
ELECTRIC-DUCTED WARM AIR
70
3.5
FLUORESCENT & TUNGSTEN
34.8
FLEXIBLE DIAPHRAGM/RIGID (GRP) INNER END ONLY
FITTED
DRIVER/GUARD-PUBLIC ADDRESS WITH TRANSMITTER
NOT FITTED
EMERGENCY-COUPLER

ALTERNATIVES

EMERGENCY TOOLBOX

TRACTION DATA FOR MULTIPLE UNITS

EMU- GLASGOW AREA. INTRODUCED 1979.
VOLTAGE 25 KV A.C. OVERHEAD
TRACTION MOTORS 4 X 110 HP GEC G310AZ OR 4 X 110 HP BRUSH TM61-53 -INTERCHANGEABLE

BASIC TYPE

EA 206 0A

VARIANTS

08 EMERGENCY TOOLBOX FITTED.

DRIVING MOTOR STANDARD

CLASS 315

DMS

EA 207

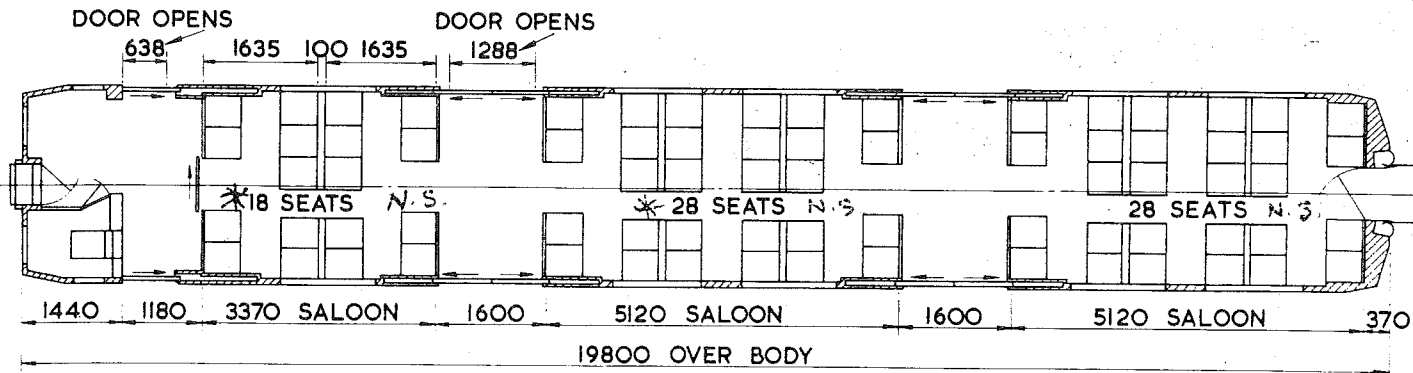
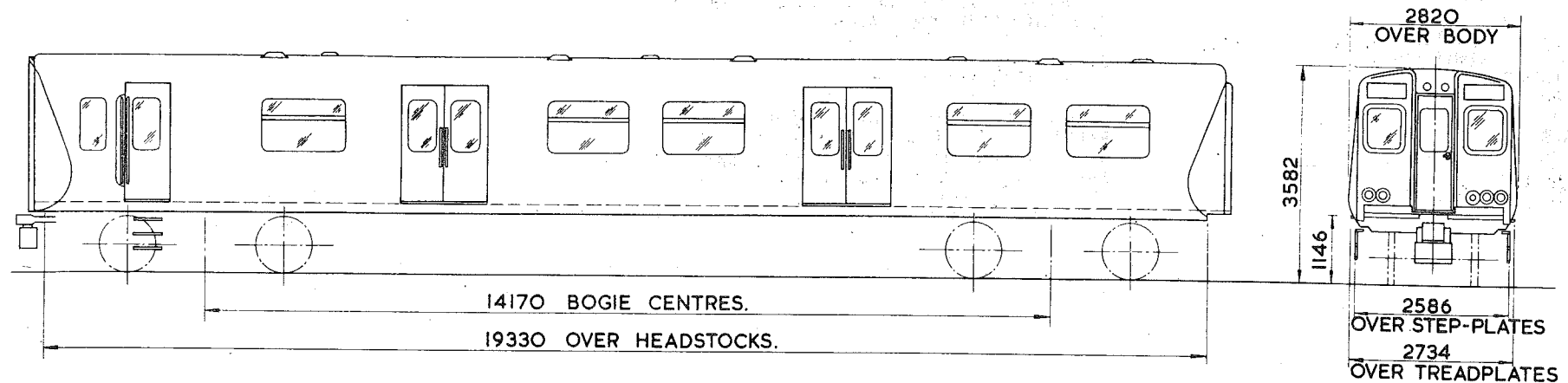

* THESE BAYS SMOKING ON SOME VEHICLES
SEE VARIANTS

VEHICLE NOS.64461-64542 ORIGINALLY
FITTED WITH BRUSH ELECTRICAL EQUIPMENT
VEHICLE NOS.64543-64582 ORIGINALLY
FITTED WITH GEC ELECTRICAL EQUIPMENT

SEATS	74
TOILETS	-
COMPARTMENTS	-
GUARDS COMPARTMENTS	CAB WHEN TRAILING
VENTILATION	-
CATERING EQUIPMENT	-

ORIGINAL DIAGRAMS FOR REFERENCE:-
BR 488 & BR 489

ISSUE DATE
5 APR 88

EA 207

BRAKES
BOGIE/SUSPENSION
BODY CONSTRUCTION
COUPLINGS
TRAIN HEATING
MAX.SPEED M.P.H.
MIN.RAD.CURVE CHAINS
LIGHTING
TARE WEIGHT TONNES
GANGWAYS
A.W.S.
TRAIN COMMUNICATION
BUFFERS
EMERGENCY EQUIPMENT

BASIC TYPE

ELECTRO PNEUMATIC
BX1/Pc & BX1/Pd(ONE OF EACH)
STEEL UNDERFRAME & BODY FRAMING-ALUMINIUM BODY & ROOF
AUTOMATIC TIGHTLOCK OUTER END-BAR INNER END
ELECTRIC-DUCTED WARM AIR
75
3.5
FLUORESCENT & TUNGSTEN
35
FLEXIBLE DIAPHRAGM/RIGID(GRP)INNER END
FITTED
DRIVER/GUARD-PUBLIC ADDRESS WITH TRANSMITTER
NOT FITTED
EMERGENCY COUPLER

ALTERNATIVES

EMERGENCY TOOLBOX

TRACTION DATA FOR MULTIPLE UNITS

EMU- LIVERPOOL ST.-SHENFIELD INNER SUBURBAN
VOLTAGE 25 KV A.C.OVERHEAD
TRACTION MOTORS 4 X 110 HP GEC G310AZ OR 4 X 110 HP BRUSH TM61-53 -INTERCHANGEABLE

BASIC TYPE

EA 207 0A

VARIANTS

OB EMERGENCY TOOLBOX FITTED,38% NON SMOKING.

DRIVING MOTOR SECOND

CLASS 508

DMS

EA 208

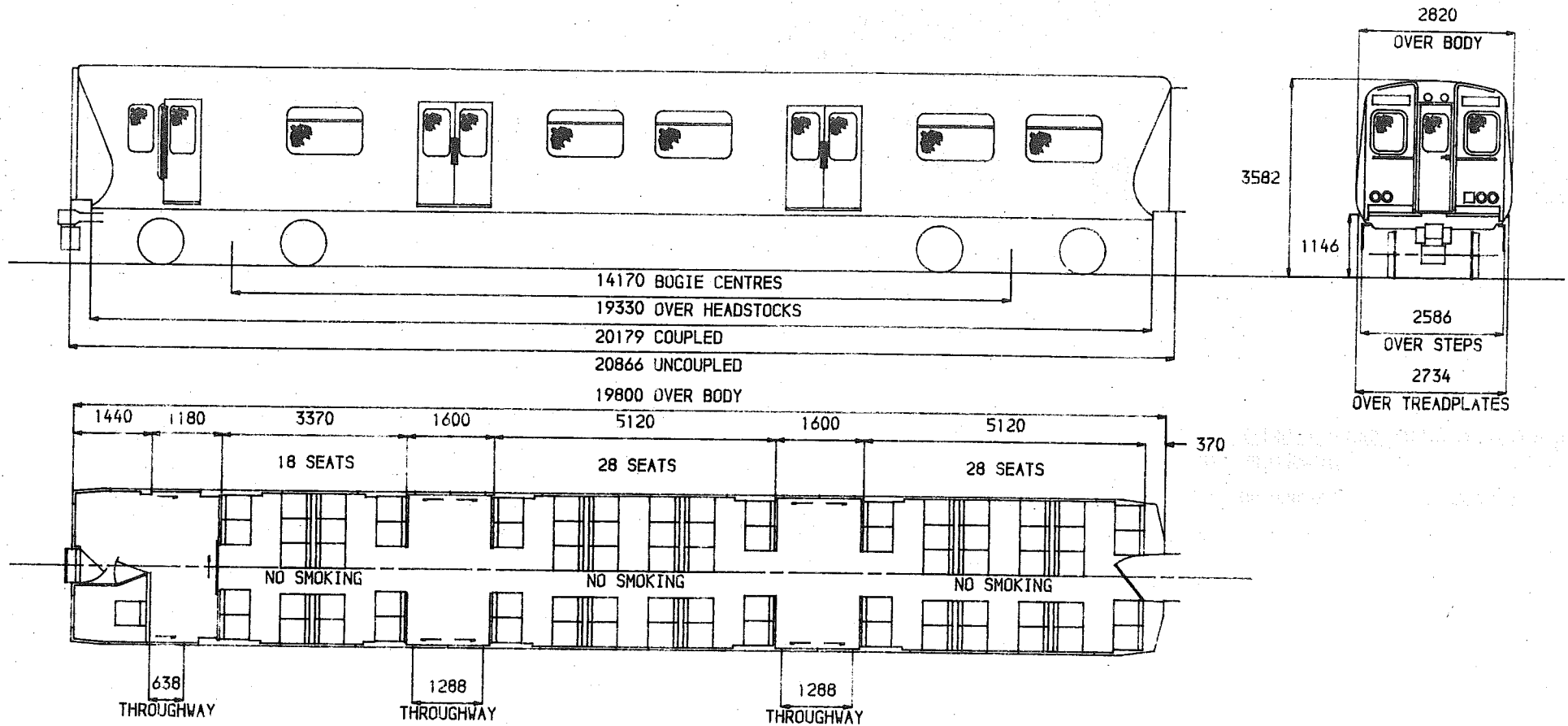

SEATS	74
TOILETS	-
COMPARTMENTS	-
GUARDS COMPARTMENTS	CAB WHEN TRAILING
VENTILATION	-
CATERING EQUIPMENT	-

ISSUE 2 DATE MAY '81

EA 208

BASIC TYPE

ALTERNATIVES

BRAKES
BOGIE/SUSPENSION
BODY CONSTRUCTION
COUPLINGS
TRAIN HEATING
MAX. SPEED M.P.H.
MIN. RAD. CURVE CHAINS
LIGHTING
TARE WEIGHT TONNES
GANGWAYS
A.V.S.
TRAIN COMMUNICATION
BUFFERS

ELECTRO PNEUMATIC
BX1/Ph & BX1/P, (ONE OF EACH)
STEEL UNDERFRAME & BODY FRAMING-ALUMINIUM BODY & ROOF
AUTOMATIC TIGHTLOCK OUTER END-BAR INNER END
ELECTRIC-DUCTED WARM AIR
75
3.5
FLUORESCENT & TUNGSTEN
36
FLEXIBLE DIAPHRAGM/RIGID (GRP) INNER END
FITTED
DRIVER/GUARD-PUBLIC ADDRESS WITH TRANSMITTER
NOT FITTED

TRACTION DATA FOR MULTIPLE UNITS

EMU- INTRODUCED 1980.
VOLTAGE 750/850 VOLTS D.C. THIRD RAIL
TRACTION MOTORS 4 X 110 HP GEC G310AZ OR 4 X 110 HP BRUSH TM61-53 -INTERCHANGEABLE

BASIC TYPE

EA 208 0A

VARIANTS

NONE

DRIVING MOTOR SECOND

CLASS 432

DMS

EA 260

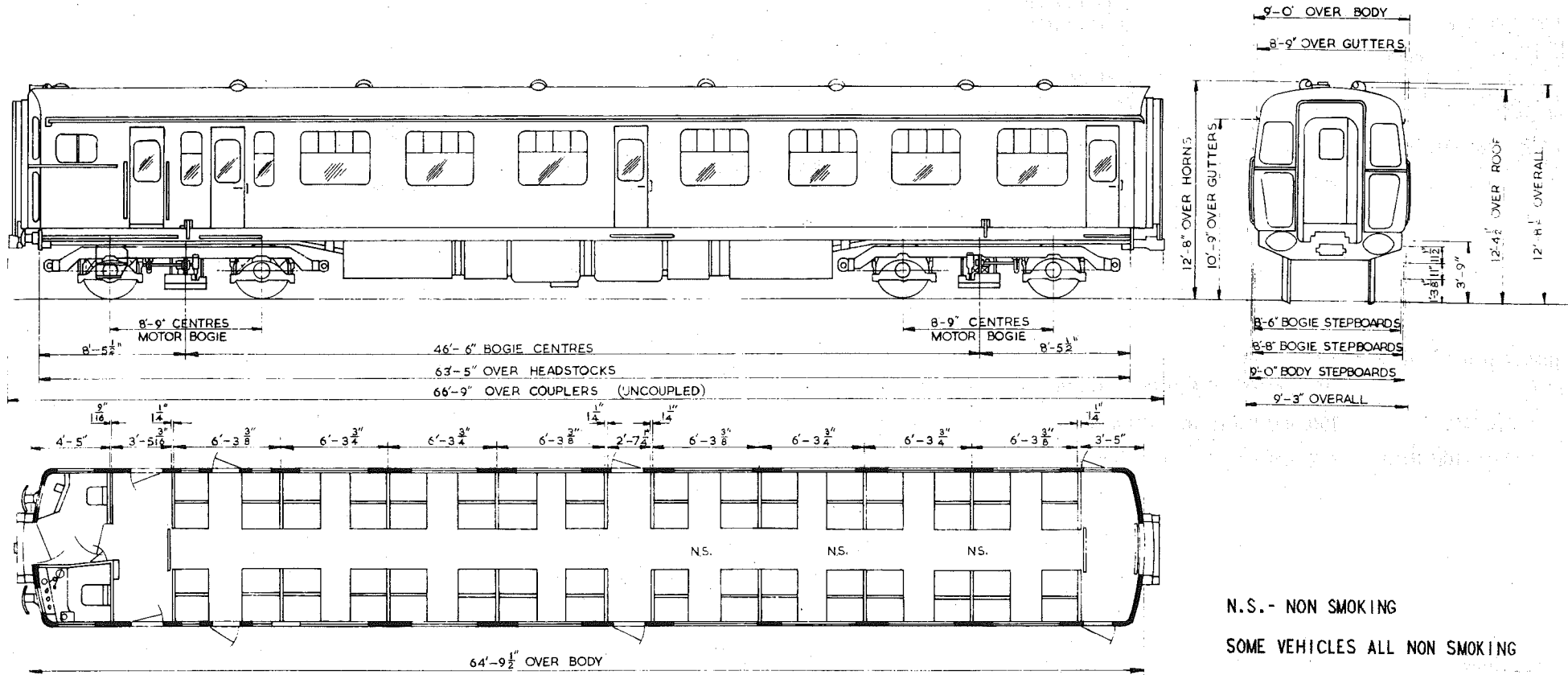

N.S. - NON SMOKING
SOME VEHICLES ALL NON SMOKING

SEATS	64
TOILETS	-
COMPARTMENTS	-
GUARDS COMPARTMENTS	-
VENTILATION	-
CATERING EQUIPMENT	-

ORIGINAL DIAGRAMS FOR REFERENCE:-
BR 890A

ISSUE 3 DATE AUG 85

EA 261

BRAKES
BOGIE/SUSPENSION
BODY CONSTRUCTION
COUPLINGS

TRAIN HEATING
MAX.SPEED M.P.H.
MIN.RAD.CURVE CHAINS
LIGHTING
TARE WEIGHT TONNES
GANGWAYS
A.W.S.
TRAIN COMMUNICATION
BUFFERS
S.R.DESIGN REFERENCE CODE

BASIC TYPE

ELECTRO PNEUMATIC
S.R.MK 4 POWERED & COMMONWEALTH UNPOWERED(ONE OF EACH)
STEEL
AUTOMATIC DROPHEAD(BUCKEYE) OUTER END-AUTOMATIC SOLID SHANK
(ALLIANCE NO.2) INNER END
ELECTRIC(BR)
90
3.5
FLUORESCENT & TUNGSTEN
41.5
EXPRESS ELECTRIC
FITTED
DRIVER/GUARD-PUBLIC ADDRESS
RETRACTABLE SPINDLE-559 X 356 OVAL OUTER END ONLY
AK

ALTERNATIVES

TRACTION DATA FOR MULTIPLE UNITS

EMU- INTRODUCED AS CLASS 411/2 1958-REFURBISHED AS PROTOTYPE & RECLASSED 1975
VOLTAGE 750/850 VOLTS D.C.THIRD RAIL
TRACTION MOTORS 2 X 250 HP ENGLISH ELECTRIC

BASIC TYPE

EA 261 1A

VARIANTS

NONE

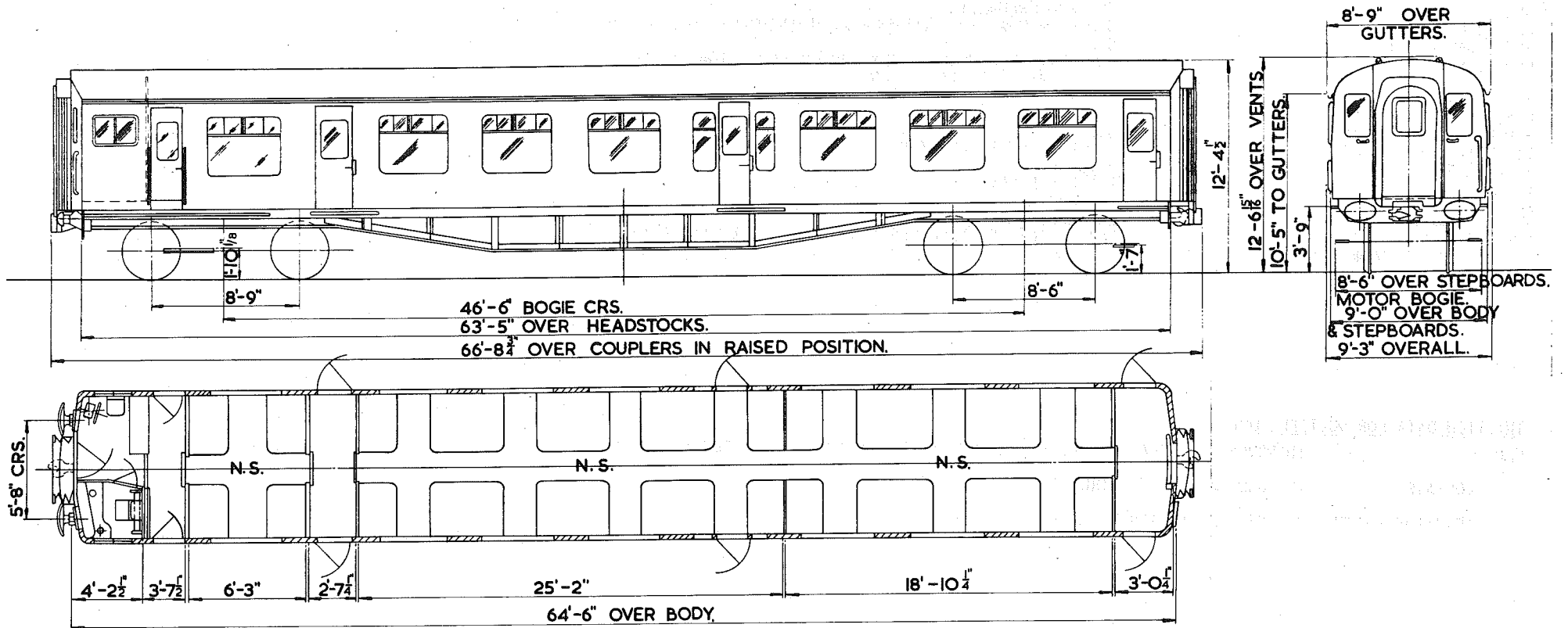

SEATS	64
TOILETS	-
COMPARTMENTS	-
GUARDS COMPARTMENTS	-
VENTILATION	-
CATERING EQUIPMENT	-

ORIGINAL DIAGRAMS FOR REFERENCE:-
BR 882

ISSUE 3 DATE MAR 86

EA 262

BRAKES
BOGIE/SUSPENSION
BODY CONSTRUCTION
COUPLINGS
TRAIN HEATING
MAX.SPEED M.P.H.
MIN.RAD.CURVE CHAINS
LIGHTING
TARE WEIGHT TONNES
GANGWAYS
A.W.S.
TRAIN COMMUNICATION
BUFFERS
S.R.DESIGN REFERENCE CODE

BASIC TYPE

ELECTRO PNEUMATIC
S.R.MK 4 POWERED & COMMONWEALTH UNPOWERED(ONE OF EACH)
STEEL
AUTOMATIC DROPHEAD(BUCKEYE) OUTER END-AUTOMATIC SOLID SHANK
(ALLIANCE NO.2) INNER END
ELECTRIC(BR)
90
3.5
FLUORESCENT & TUNGSTEN
41.5
EXPRESS ELECTRIC
FITTED
DRIVER/GUARD
RETRACTABLE SPINDLE-559 X 356 OVAL-OUTER END ONLY
AL

ALTERNATIVES

TRACTION DATA FOR MULTIPLE UNITS

EMU- INTRODUCED AS CLASS 411/2 1958-REFURBISHED AS PROTOTYPE & RECLASSE D 1975
VOLTAGE 750/850 VOLTS D.C. THIRD RAIL
TRACTION MOTORS 2 X 250 HP ENGLISH ELECTRIC

BASIC TYPE

EA 262 1A

VARIANTS

NONE

DRIVING MOTOR SECOND

CLASS 412
411/4

DMS

EA 263

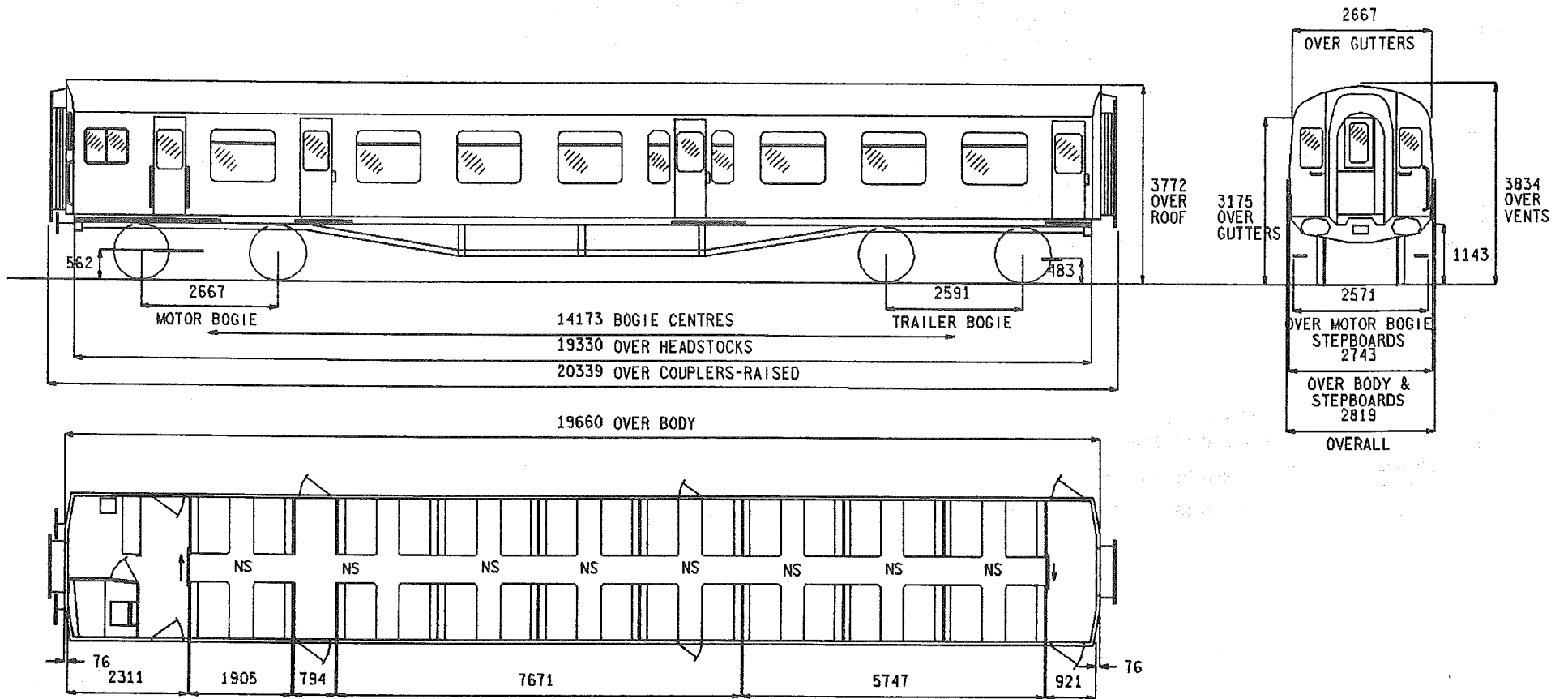

SEATS	64
TOILETS	-
COMPARTMENTS	-
GUARDS COMPARTMENTS	-
VENTILATION	-
CATERING EQUIPMENT	-

ISSUE 3 DATE NOV 84

EA 263

BRAKES
BOGIE/SUSPENSION
BODY CONSTRUCTION
COUPLINGS

TRAIN HEATING
MAX. SPEED M.P.H.
MIN. RAD. CURVE CHAINS
LIGHTING
TARE WEIGHT TONNES
GANGWAYS
A.W.S.
TRAIN COMMUNICATION
BUFFERS
S.R. DESIGN REFERENCE CODE

BASIC TYPE

ELECTRO PNEUMATIC
S.R. MK 4 POWERED & COMMONWEALTH UNPOWERED (ONE OF EACH)
STEEL
AUTOMATIC DROPHEAD (BUCKEYE) OUTER END - AUTOMATIC SOLID SHANK
(ALLIANCE NO. 2) INNER END
ELECTRIC (BR)
90
3.5
FLUORESCENT & TUNGSTEN
41
EXPRESS ELECTRIC
FITTED
DRIVER/GUARD - PUBLIC ADDRESS
RETRACTABLE SPINDLE (559 X 356 OVAL) OUTER END ONLY
AO

ALTERNATIVES

TRACTION DATA FOR MULTIPLE UNITS

EMU- INTRODUCED 1956-REFURBISHED 1980.
VOLTAGE 750/850 VOLTS D.C. THIRD RAIL
TRACTION MOTORS 2 X 250 HP ENGLISH ELECTRIC

BASIC TYPE

EA 263 0A-REFURBISHED

VARIANTS

NONE

DRIVING MOTOR SECOND

CLASS 412
411/5

DMS

EA 264

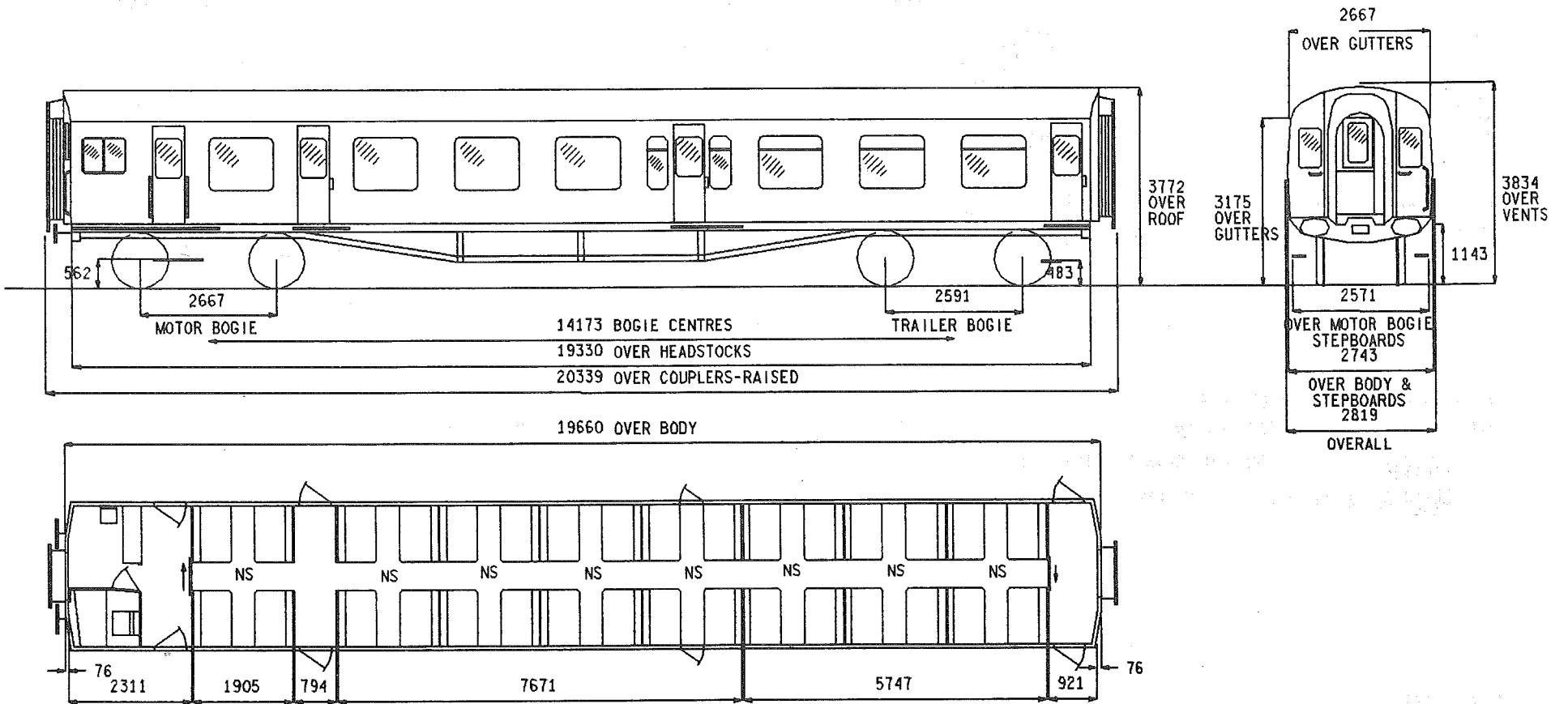

SEATS	64
TOILETS	-
COMPARTMENTS	-
GUARDS COMPARTMENTS	-
VENTILATION	-
CATERING EQUIPMENT	-

ORIGINAL DIAGRAMS FOR REFERENCE:-
BR 884

ISSUE 5 DATE NOV '84

EA 264

BRAKES
BOGIE/SUSPENSION
BODY CONSTRUCTION
COUPLINGS
TRAIN HEATING
MAX.SPEED M.P.H.
MIN.RAD.CURVE CHAINS
LIGHTING
TARE WEIGHT TONNES
GANGWAYS
A.W.S.
TRAIN COMMUNICATION
BUFFERS
S.R.DESIGN REFERENCE CODE

BASIC TYPE

ELECTRO PNEUMATIC
S.R.MK 4 POWERED & COMMONWEALTH UNPOWERED(ONE OF EACH)
STEEL
AUTOMATIC DROPHEAD(BUCKEYE) OUTER END-AUTOMATIC SOLID SHANK
(ALLIANCE NO.2) INNER END
ELECTRIC(BR)
90
3.5
FLUORESCENT & TUNGSTEN
41
EXPRESS ELECTRIC
FITTED
DRIVER/GUARD-PUBLIC ADDRESS
RETRACTABLE SPINDLE-559 X 356 OVAL-OUTER END ONLY
AK

ALTERNATIVES

S.R.MK 3B POWERED & COMMONWEALTH UNPOWERED(ONE OF EACH)

AL, AM, AN, AN 1A, AM 1A

TRACTION DATA FOR MULTIPLE UNITS

EMU- INTRODUCED-CLASS 410/2 1959-CLASS 411/2 1958.REFURBISHED 1980.411/1&2 RECLASSIFIED 411/5.
VOLTAGE 750/850 VOLTS D.C.THIRD RAIL
TRACTION MOTORS 2 X 250 HP ENGLISH ELECTRIC

BASIC TYPE

EA 264 0A-REFURBISHED

VARIANTS

1A REFURBISHED-S.R.DESIGN REFERENCE CODE AM.
2B REFURBISHED-S.R.DESIGN REFERENCE CODE AM 1A,S.R.MK 3B POWERED & COMMONWEALTH UNPOWERED BOGIES(ONE OF EACH).
3A REFURBISHED-S.R.DESIGN REFERENCE CODE AL.
4B REFURBISHED-S.R.DESIGN REFERENCE CODE AN,S.R.MK 3B POWERED & COMMONWEALTH UNPOWERED BOGIES(ONE OF EACH).
5A REFURBISHED-S.R.DESIGN REFERENCE CODE AN 1A.

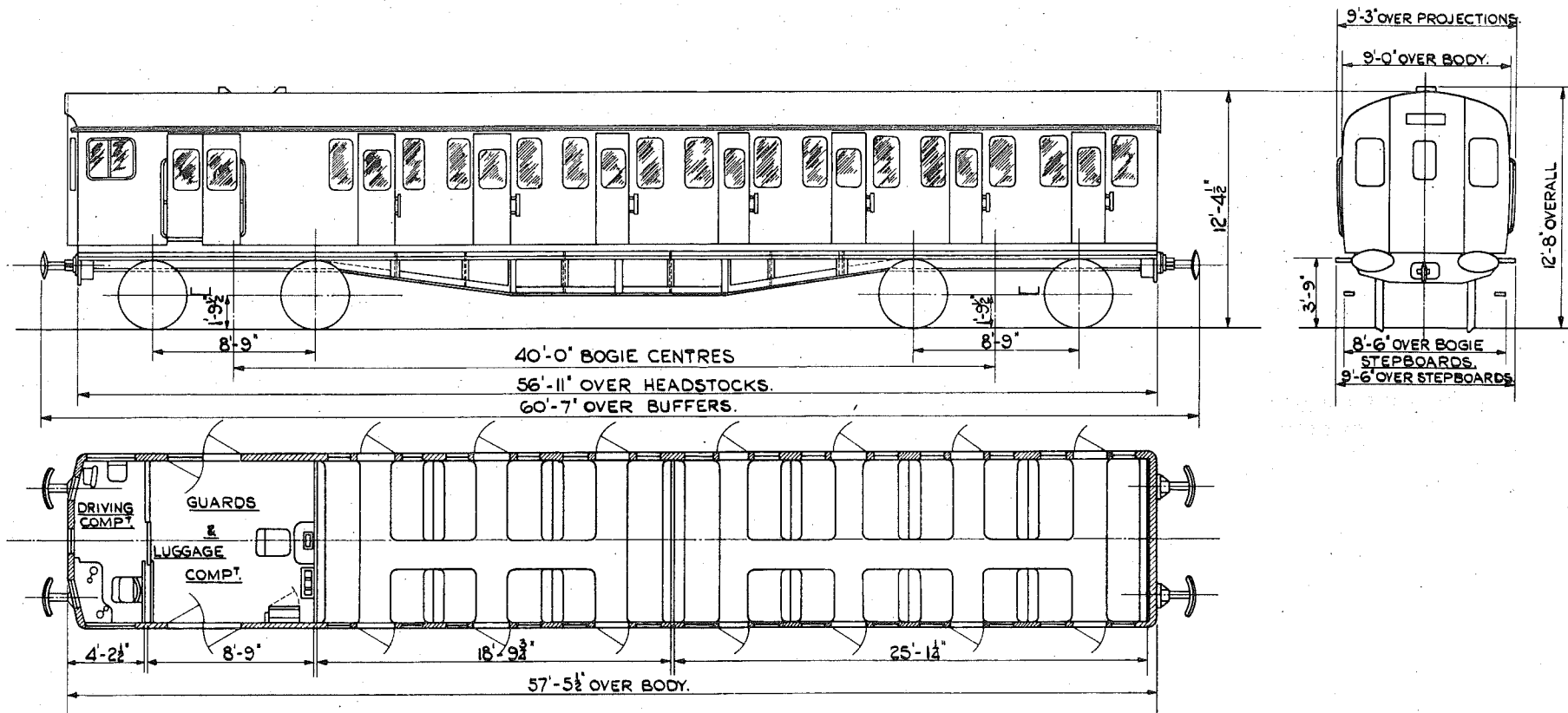

SEATS	74
TOILETS	-
COMPARTMENTS	-
GUARDS COMPARTMENTS	1
VENTILATION	-
CATERING EQUIPMENT	-

ORIGINAL DIAGRAMS FOR REFERENCE.-
BR 403

ISSUE 2 DATE MAY '81

EB 201

BASIC TYPE

BRAKES
BOGIE/SUSPENSION
BODY CONSTRUCTION
COUPLINGS
TRAIN HEATING
MAX. SPEED M.P.H.
MIN. RAD. CURVE CHAINS
LIGHTING
TARE WEIGHT TONNES
GANGWAYS
A.V.S.
TRAIN COMMUNICATION
BUFFERS

ELECTRO PNEUMATIC
CLASS 501 MOTOR
STEEL
SCREW
ELECTRIC (BR)
70
3.5
TUNGSTEN
48
NOT FITTED
NOT FITTED
NOT FITTED
SPINDLE-559 X 356 OVAL

ALTERNATIVES

TRACTION DATA FOR MULTIPLE UNITS

EMU- LONDON DISTRICT. INTRODUCED 1957.
VOLTAGE 630 VOLTS D.C. THIRD RAIL
TRACTION MOTORS 4 X 185 HP GEC

BASIC TYPE

EB 201 0A

VARIANTS

NONE

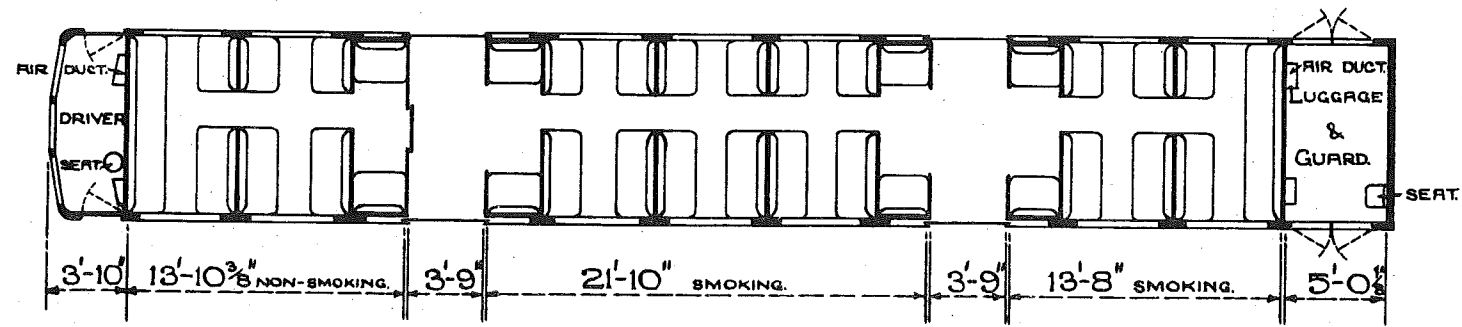
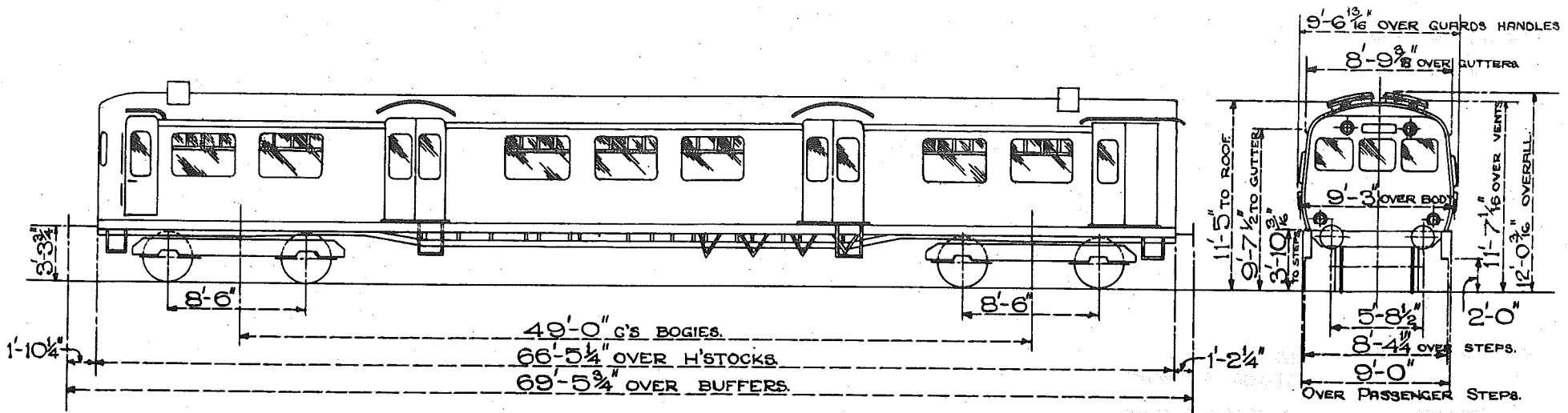

SEATS	88
TOILETS	-
COMPARTMENTS	-
GUARDS COMPARTMENTS	1
VENTILATION	-
CATERING EQUIPMENT	-

ORIGINAL DIAGRAMS FOR REFERENCE.-
LMS 345

ISSUE 2 DATE MAY '81

EB 202

BASIC TYPE

BRAKES
BOGIE/SUSPENSION
BODY CONSTRUCTION
COUPLINGS
TRAIN HEATING
MAX. SPEED M.P.H.
MIN. RAD. CURVE CHAINS
LIGHTING
TARE WEIGHT TONNES
GANGWAYS
A.V.S.
TRAIN COMMUNICATION
BUFFERS

ELECTRO PNEUMATIC
CLASS 502 MOTOR
STEEL
SCREW (OUTER END LOOSE COUPLED, INNER END CLOSE COUPLED)
ELECTRIC (BR)
65
3.5
TUNGSTEN
42.5
NOT FITTED
NOT FITTED
DRIVER-GUARD
SELF CONTAINED 457 DIA.

ALTERNATIVES

TRACTION DATA FOR MULTIPLE UNITS

EMU- LIVERPOOL-SOUTHPORT. INTRODUCED 1939.
VOLTAGE 630 VOLTS D.C. THIRD RAIL
TRACTION MOTORS 4 X 235 HP ENGLISH ELECTRIC

BASIC TYPE

EB 202 0A

VARIANTS

NONE

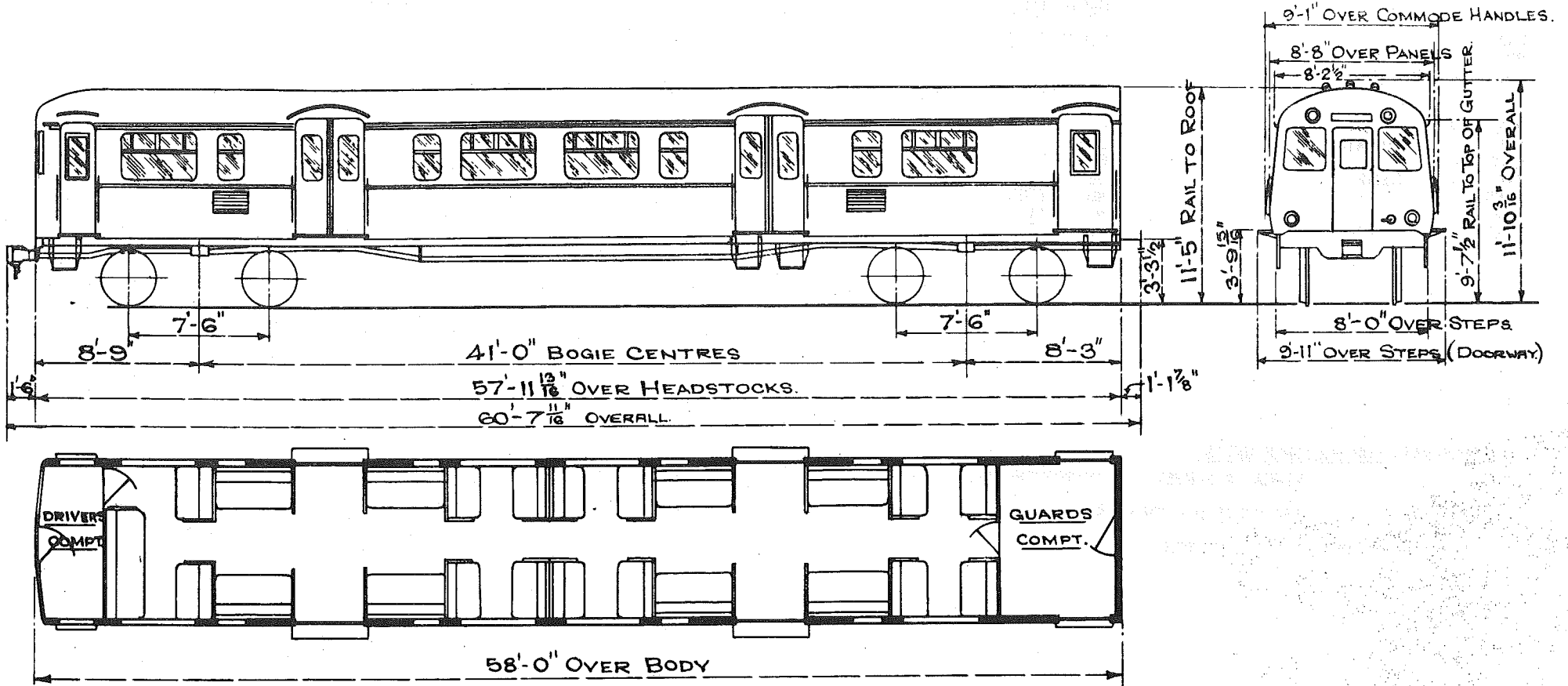

SEATS	56
TOILETS	-
COMPARTMENTS	-
GUARDS COMPARTMENTS	1
VENTILATION	-
CATERING EQUIPMENT	-

ORIGINAL DIAGRAMS FOR REFERENCE.-
LMS 344A

ISSUE 1 DATE SEP '80

EB 203

BRAKES
BOGIE/SUSPENSION
BODY CONSTRUCTION
COUPLINGS
TRAIN HEATING
MAX. SPEED M.P.H.
MIN. RAD. CURVE CHAINS
LIGHTING
TARE WEIGHT TONNES
GANGWAYS
A. V. S.
TRAIN COMMUNICATION
BUFFERS

BASIC TYPE

ELECTRO PNEUMATIC
CLASS 503 MOTOR
STEEL
AUTOMATIC SOILD SHANK (ALLIANCE NO.2) OUTER END-PERMANENT SCREW INNER END
ELECTRIC (BR)
65
3.5
ELECTRIC
36.5
NOT FITTED
NOT FITTED
NOT FITTED
SPINDLE-457 DIA.-INNER END ONLY

ALTERNATIVES

TRACTION DATA FOR MULTIPLE UNITS

EMU- WIRRAL & MERSEY. INTRODUCED 1938 & 1956
VOLTAGE 650 VOLTS D.C. THIRD RAIL
TRACTION MOTORS 4 X 135 HP BTH

BASIC TYPE

EB 203 0A

VARIANTS

NONE

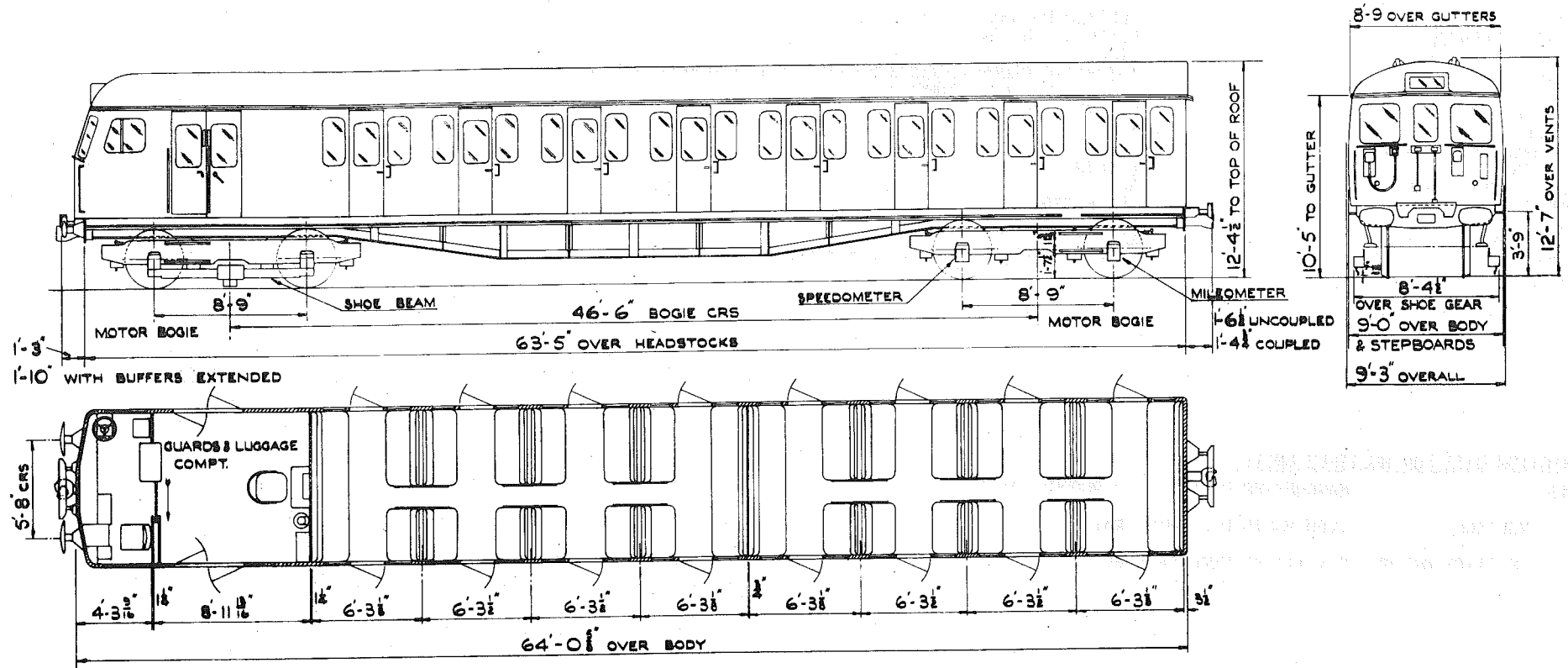

SEATS	84
TOILETS	-
COMPARTMENTS	-
GUARDS COMPARTMENTS	1
VENTILATION	-
CATERING EQUIPMENT	-

ORIGINAL DIAGRAMS FOR REFERENCE, -
BR 407

ISSUE 1 DATE SEP' 80

EB 204

BASIC TYPE

BRAKES
BOGIE/SUSPENSION
BODY CONSTRUCTION
COUPLINGS

ELECTRO PNEUMATIC
CLASS 504 MOTOR
STEEL
AUTOMATIC DROPHEAD (BUCKEYE) OUTER END-AUTOMATIC SOLID SHANK
(ALLIANCE NO.2) INNER END
ELECTRIC (BR)
65
3.5
ELECTRIC
50
NOT FITTED
NOT FITTED
NOT FITTED
RETRACTABLE SPINDLE-559 X 356 OVAL

ALTERNATIVES

TRAIN HEATING
MAX. SPEED M.P.H.
MIN. RAD. CURVE CHAINS
LIGHTING
TARE WEIGHT TONNES
GANGWAYS
A.W.S.
TRAIN COMMUNICATION
BUFFERS

TRACTION DATA FOR MULTIPLE UNITS

EMU- MANCHESTER-BURY. INTRODUCED 1959.
VOLTAGE 1200 VOLTS D.C. THIRD RAIL
TRACTION MOTORS 2 X 141 HP ENGLISH ELECTRIC

BASIC TYPE

EB 204 0A

VARIANTS

NONE

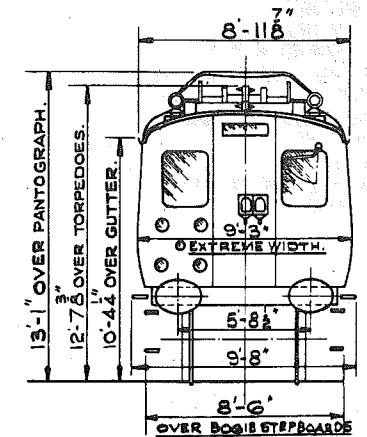
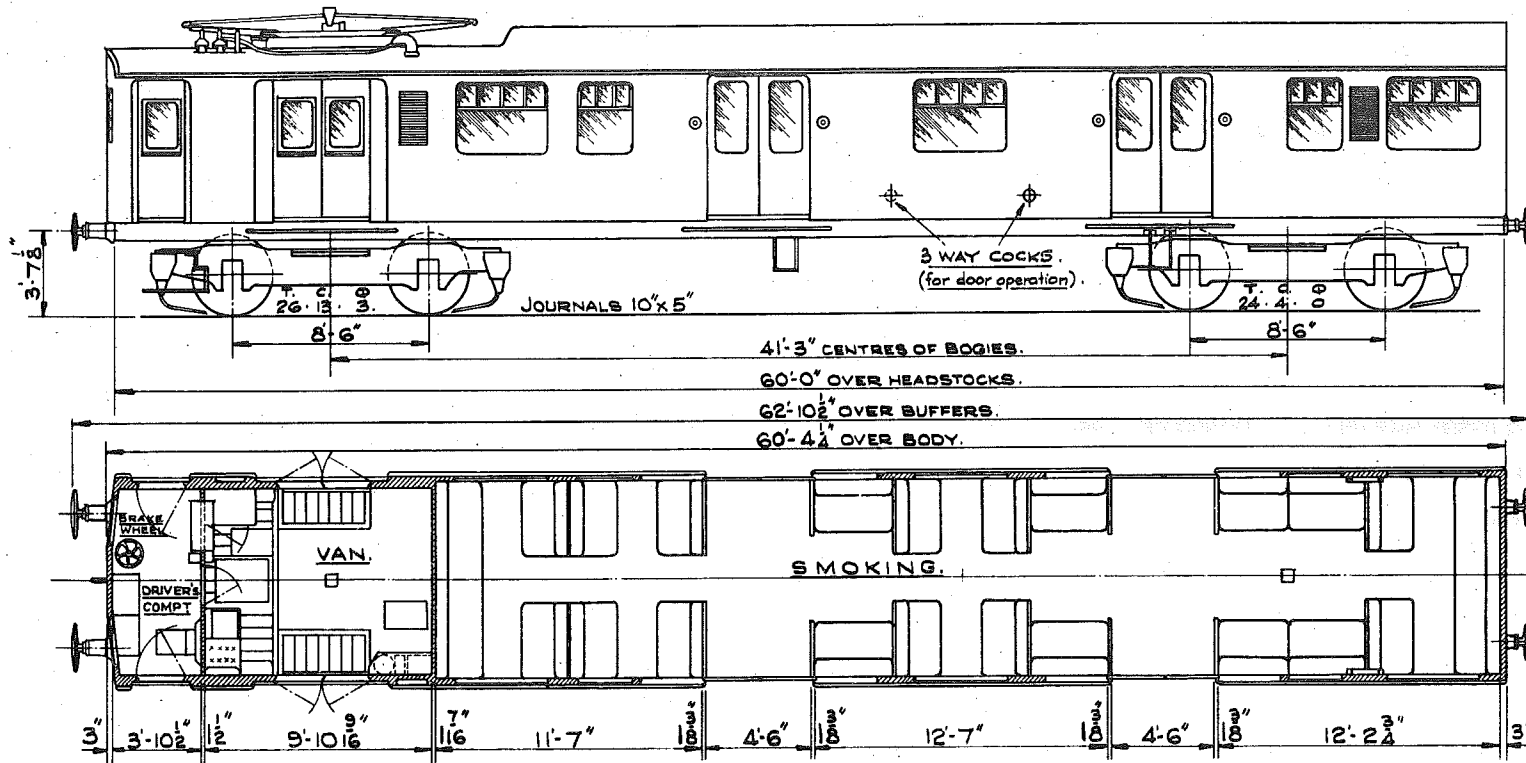

SEATS	52
TOILETS	-
COMPARTMENTS	-
GUARDS COMPARTMENTS	1
VENTILATION	-
CATERING EQUIPMENT	-

ORIGINAL DIAGRAMS FOR REFERENCE.-
LNE 363

ISSUE 2 DATE MAY '81

EB 205

BASIC TYPE

BRAKES
BOGIE/SUSPENSION
BODY CONSTRUCTION
COUPLINGS
TRAIN HEATING
MAX. SPEED M.P.H.
MIN. RAD. CURVE CHAINS
LIGHTING
TARE WEIGHT TONNES
GANGWAYS
A. V. S.
TRAIN COMMUNICATION
BUFFERS

ELECTRO PNEUMATIC
CLASS 506 MOTOR
STEEL
SCREW
ELECTRIC (BR)
70
3.5
TUNGSTEN
52
NOT FITTED
NOT FITTED
NOT FITTED
SELF CONTAINED-559 OVAL

ALTERNATIVES

TRACTION DATA FOR MULTIPLE UNITS

EMU- MANCHESTER-GLOSSOP-HADFIELD. INTRODUCED 1954.
VOLTAGE 1500 VOLTS D.C. OVERHEAD
TRACTION MOTORS 4 X 185 HP GEC

BASIC TYPE

EB 205 0A

VARIANTS

NONE

MOTOR BRAKE SECOND

CLASS 309/1

DMBS

EB 207

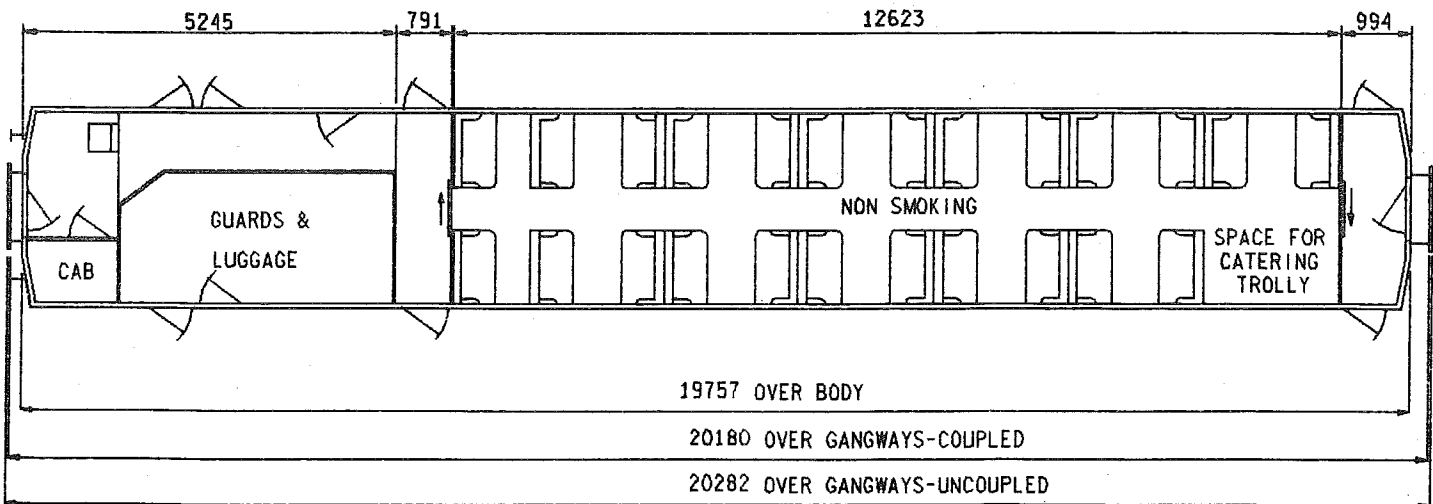
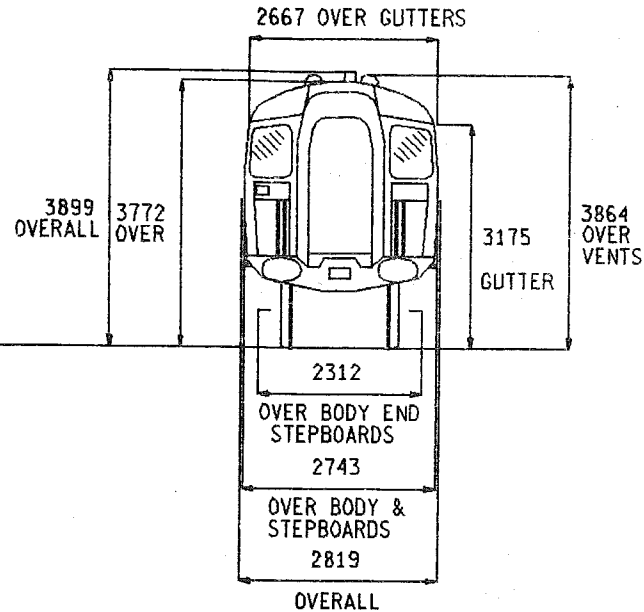
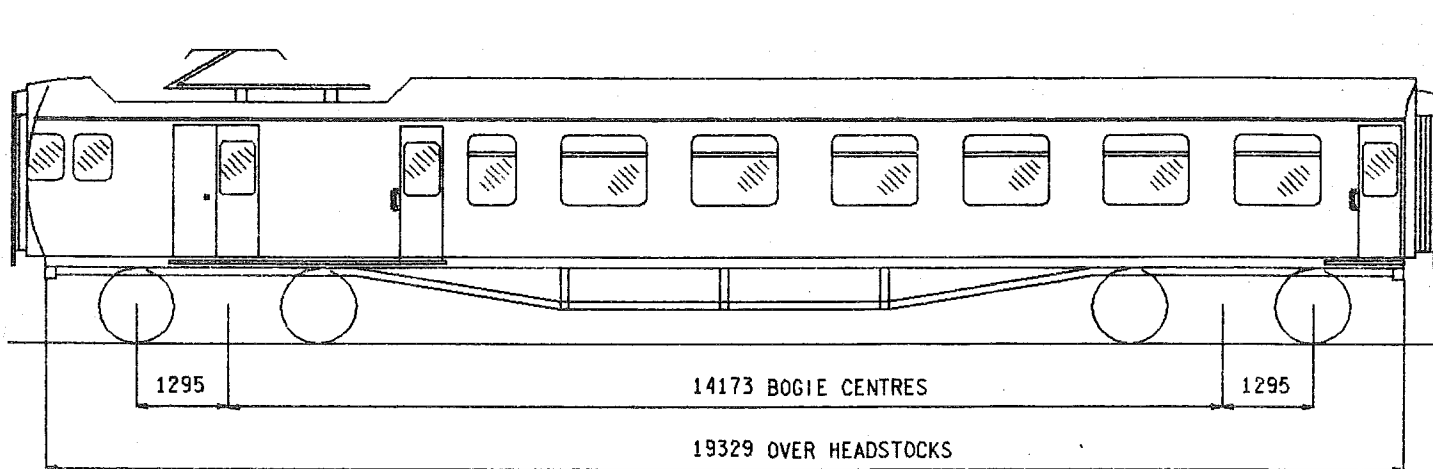

SEATS	48
TOILETS	-
COMPARTMENTS	-
GUARDS COMPARTMENTS	1
VENTILATION	-
CATERING EQUIPMENT	TROLLEY

ISSUE 2 DATE MAR 87

EB 207

BASIC TYPE

ALTERNATIVES

BRAKES
BOGIE/SUSPENSION
BODY CONSTRUCTION
COUPLINGS

ELECTRO PNEUMATIC
COMMONWEALTH (POWERED)
STEEL
AUTOMATIC DRORHEAD (BUCKEYE) OUTER END
AUTOMATIC SOLID SHANK (ALLIANCE NO.2) INNER END
ELECTRIC (BR)
100
3.5
FLOURESCENT
60.5
PULLMAN
PUBLIC ADDRESS
RETRACTABLE SPINDLE-559x356 OVAL-OUTER END ONLY

TRAIN HEATING
MAX. SPEED M.P.H.
MIN. RAD. CURVE CHAINS
LIGHTING
TARE WEIGHT TONNES
GANGWAYS
TRAIN COMMUNICATION
BUFFERS

TRACTION DATA FOR MULTIPLE UNITS

EMU- LIVERPOOL ST.-CLACTON & WALTON INTRODUCED 1962, REFURBISHED 1985.
VOLTAGE 25 & 6.25 KV A.C. OVERHEAD.
TRACTION MOTORS 4 x 282 HP D.C. GEC

BASIC TYPE
EB 207 0A

VARIANTS
NONE

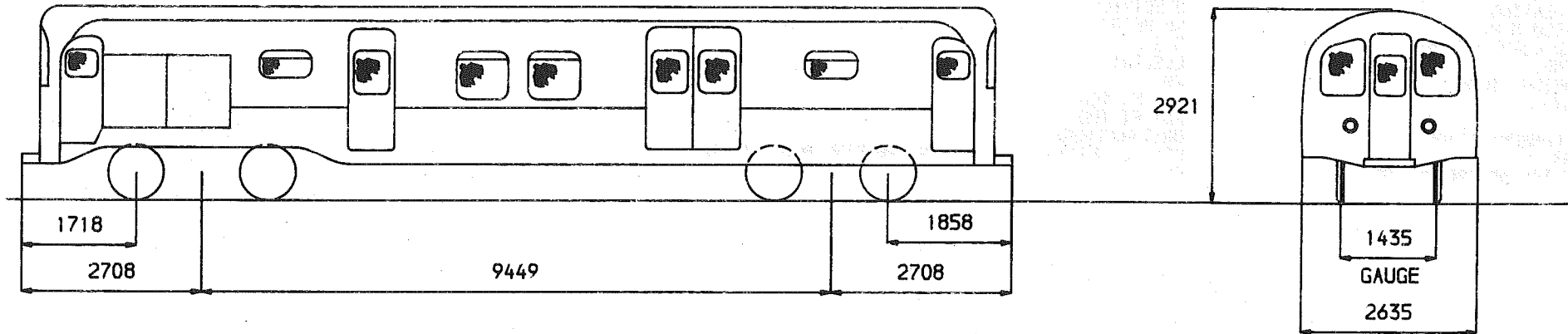

14326 OVER BODY

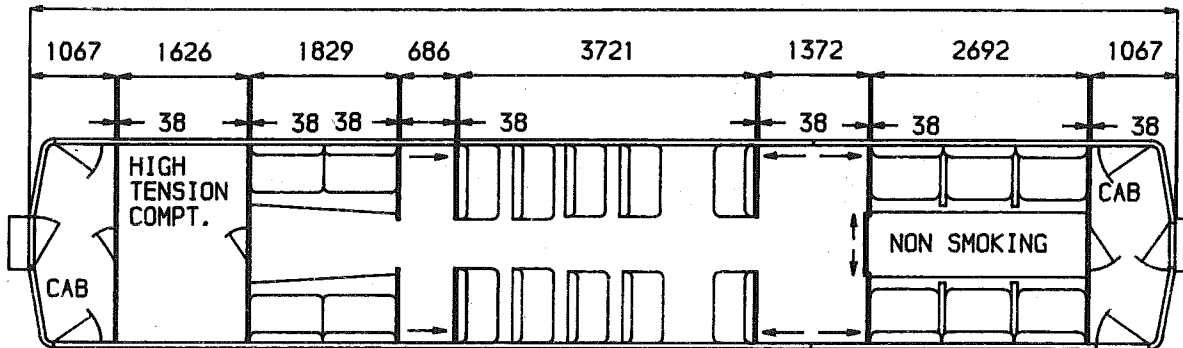

- SEATS 40
- TOILETS -
- COMPARTMENTS -
- GUARDS COMPARTMENTS -
- VENTILATION -
- CATERING EQUIPMENT -

ORIGINAL DIAGRAMS FOR REFERENCE.-
S.R. 842

ISSUE 1 DATE SEP' 80

EB 260

BRAKES
BOGIE/SUSPENSION
BODY CONSTRUCTION
COUPLINGS
TRAIN HEATING
MAX. SPEED M.P.H.
MIN. RAD. CURVE CHAINS
LIGHTING
TARE WEIGHT TONNES
GANGWAYS
A.V.S.
TRAIN COMMUNICATION
BUFFERS
S.R. DESIGN REFERENCE CODE

BASIC TYPE

AIR
BP22-WATERLOO & CITY
STEEL
WATERLOO & CITY
ELECTRIC (BR)
NO RECORD
3.5
ELECTRIC
29
NOT FITTED
NOT FITTED
DRIVER/GUARD
CENTRE SPRING A END-CENTRE WEARING BLOCK B END
CV

ALTERNATIVES

TRACTION DATA FOR MULTIPLE UNITS

EMU- WATERLOO & CITY. INTRODUCED 1940
VOLTAGE 750/850 VOLTS D.C. THIRD RAIL
TRACTION MOTORS 2 X 190 HP ENGLISH ELECTRIC

BASIC TYPE

EB 260 0A

VARIANTS

NONE

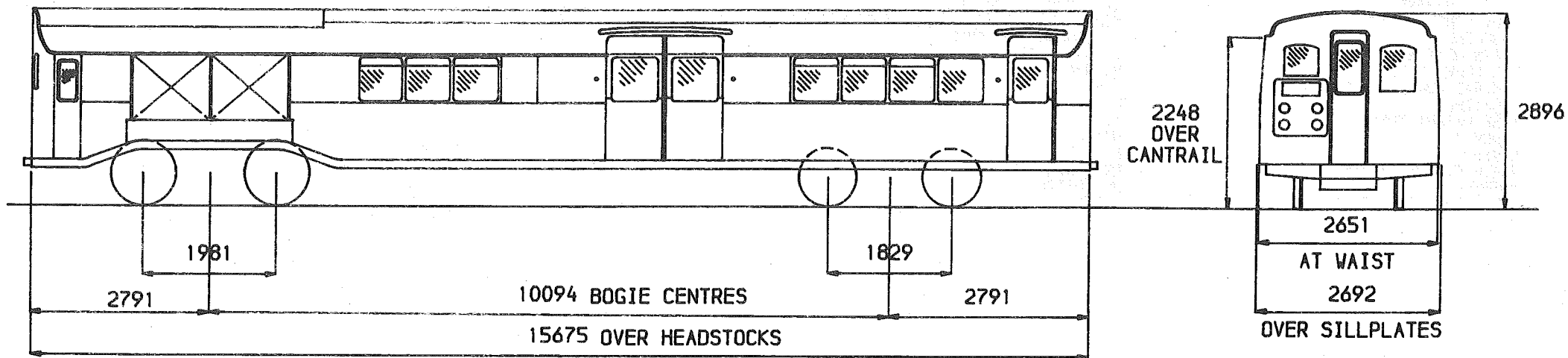

16189 OVER BUFFERS (FREE)

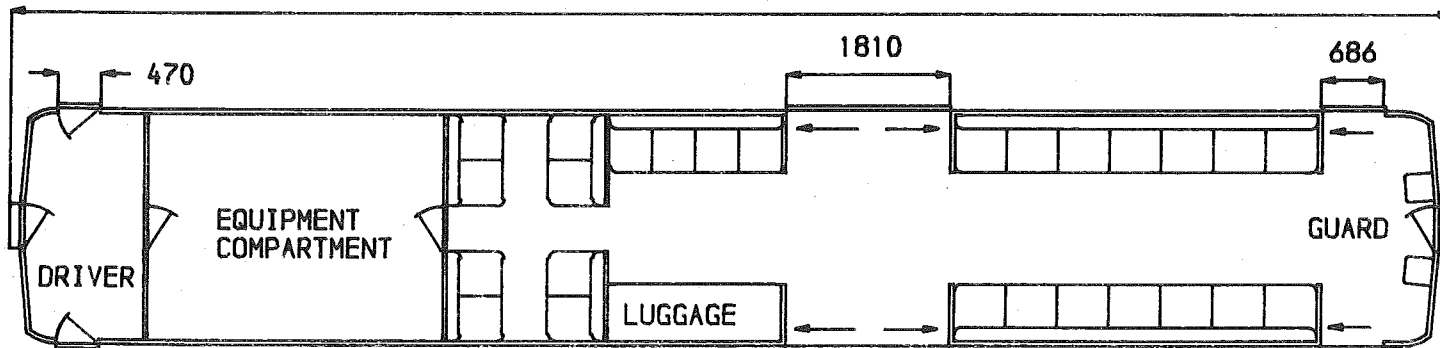

SEATS	26
TOILETS	-
COMPARTMENTS	-
GUARDS COMPARTMENTS	1
VENTILATION	-
CATERING EQUIPMENT	-

ORIGINAL DIAGRAMS FOR REFERENCE.-
S.R. 848

ISSUE 1 DATE SEP' 80

EB 261

BASIC TYPE

ALTERNATIVES

BRAKES
BOGIE/SUSPENSION
BODY CONSTRUCTION
COUPLINGS
TRAIN HEATING
MAX. SPEED M.P.H.
MIN. RAD. CURVE CHAINS
LIGHTING
TARE WEIGHT TONNES
GANGWAYS
A.V.S.
TRAIN COMMUNICATION
BUFFERS
S.R. DESIGN REFERENCE CODE

ELECTRO PNEUMATIC
EX LONDON TRANSPORT
STEEL UNDERFRAME BODY & ROOF-WOODEN BODY FRAMING
EX LONDON TRANSPORT
ELECTRIC (BR)
NO RECORD
3.5
ELECTRIC
32
NOT FITTED
FITTED
DRIVER/GUARD
NOT FITTED
CVAEND

FITTED

CVDEND

TRACTION DATA FOR MULTIPLE UNITS

EMU- ISLE OF WIGHT STOCK. INTRODUCED 1967-EX LONDON TRANSPORT STOCK
VOLTAGE 630 VOLTS D.C. THIRD RAIL
TRACTION MOTORS 2 X 240 HP

BASIC TYPE

EB 261 0A

VARIANTS

1A S.R. DESIGN REFERENCE CODE CVDEND, A.V.S. FITTED.

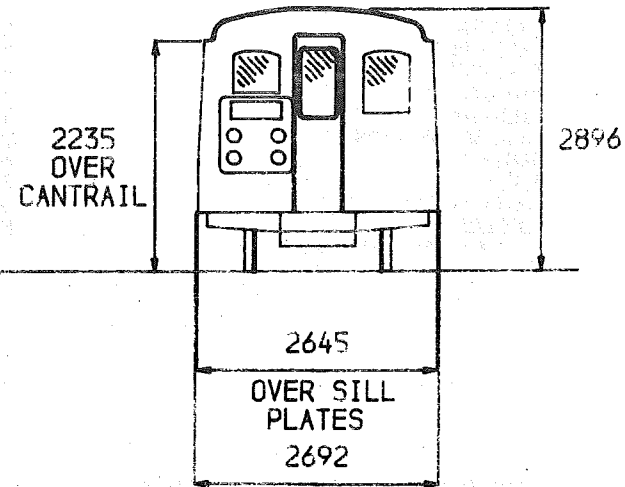
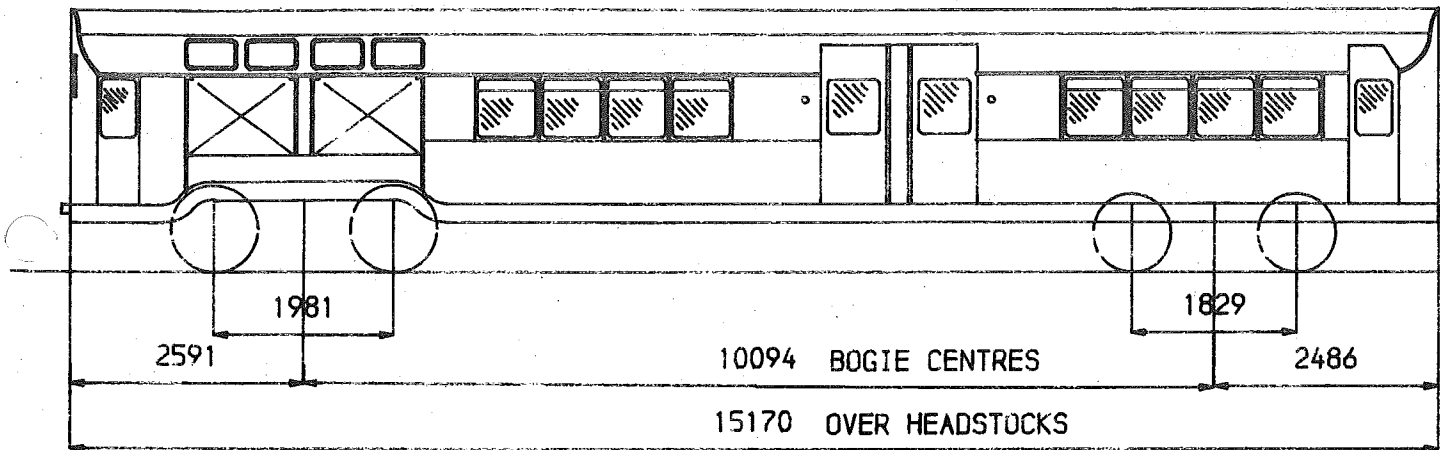

15685 OVER BUFFERS (FREE)

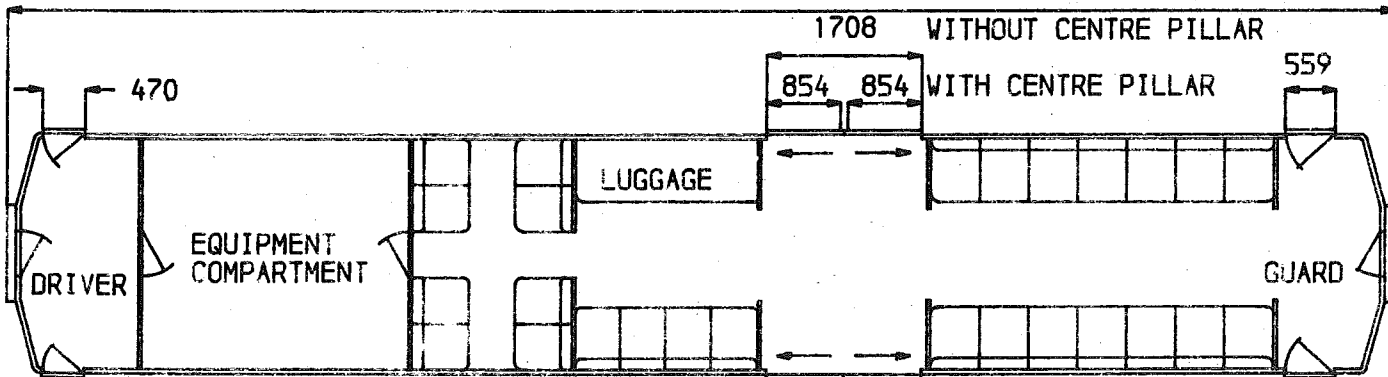

SEATS	26
TOILETS	-
COMPARTMENTS	-
GUARDS COMPARTMENTS	1
VENTILATION	-
CATERING EQUIPMENT	-

ORIGINAL DIAGRAMS FOR REFERENCE.-
 SR 848

ISSUE 2 DATE MAY '81

EB 262

BASIC TYPE

BRAKES
BOGIE/SUSPENSION
BODY CONSTRUCTION
COUPLINGS
TRAIN HEATING
MAX. SPEED M.P.H.
MIN. RAD. CURVE CHAINS
LIGHTING
TARE WEIGHT TONNES
GANGWAYS
A.W.S.
TRAIN COMMUNICATION
BUFFERS
S.R. DESIGN REFERENCE CODE

ELECTRO PNEUMATIC
EX LONDON TRANSPORT
STEEL UNDERFRAME BODY & ROOF-WOODEN BODY FRAMING
EX LONDON TRANSPORT
ELECTRIC (BR)
NO RECORD
3.5
TUNGSTEN
29
NOT FITTED
FITTED
DRIVER/GUARD-PUBLIC ADDRESS
NOT FITTED
CV 1AA

ALTERNATIVES

NOT FITTED
DRIVER/GUARD
CV 1AD

TRACTION DATA FOR MULTIPLE UNITS

EMU- ISLE OF WIGHT STOCK. INTRODUCED 1967-EX LONDON TRANSPORT STOCK.
VOLTAGE 630 VOLTS D.C. THIRD RAIL
TRACTION MOTORS 2 X 240 HP

BASIC TYPE

EB 262 0A

VARIANTS

1A A.W.S. NOT FITTED, DRIVER/GUARD, S.R. DESIGN REF. CODE CV 1AD

DRIVING MOTOR BRAKE SECOND

CLASS 405

DMBS

EB 265

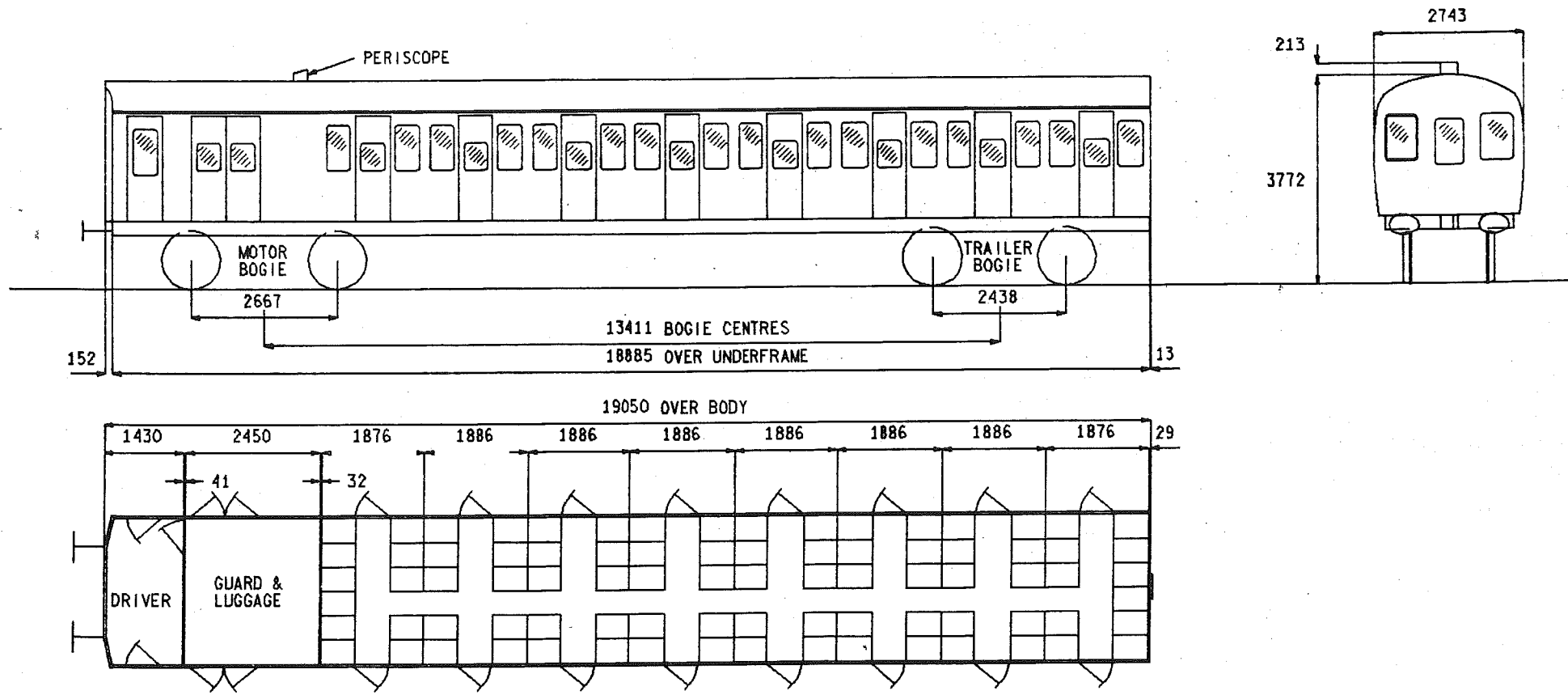

SEATS	82
TOILETS	-
COMPARTMENTS	-
GUARDS COMPARTMENTS	1
VENTILATION	-
CATERING EQUIPMENT	-

ORIGINAL DIAGRAMS FOR REFERENCE:-
SR 2126

ISSUE 3 DATE MAR 86

EB 265

BRAKES
BOGIE/SUSPENSION
BODY CONSTRUCTION
COUPLINGS
TRAIN HEATING
MAX.SPEED M.P.H.
MIN.RAD.CURVE CHAINS
LIGHTING
TARE WEIGHT TONNES
GANGWAYS
A.W.S.
TRAIN COMMUNICATION
BUFFERS
S.R.DESIGN REFERENCE CODE

BASIC TYPE

AIR
CENTRAL 1092 MOTOR WHEEL & S.R.STD 229 X 114(ONE OF EACH)
STEEL
AUTOMATIC DROPHEAD(BUCKEYE) OUTER END 3 LINK INNER END
ELECTRIC(BR)
75
3.5
TUNGSTEN
39
NOT FITTED
NOT FITTED
NOT FITTED
SELF CONTAINED SPENCER MOULTON OUTER END CENTRE WEARING PLATE
INNER END
CM 507

ALTERNATIVES

CM

TRACTION DATA FOR MULTIPLE UNITS

EMU- INTRODUCED 1946.
VOLTAGE 750/850 VOLTS D.C.THIRD RAIL
TRACTION MOTORS 2 X 250 HP ENGLISH ELECTRIC

BASIC TYPE

EB 265 2C

VARIANTS

2D SR DESIGN REF.CODE CM.

DRIVING MOTOR BRAKE SECOND

CLASS 415/0

DMBS

EB 266

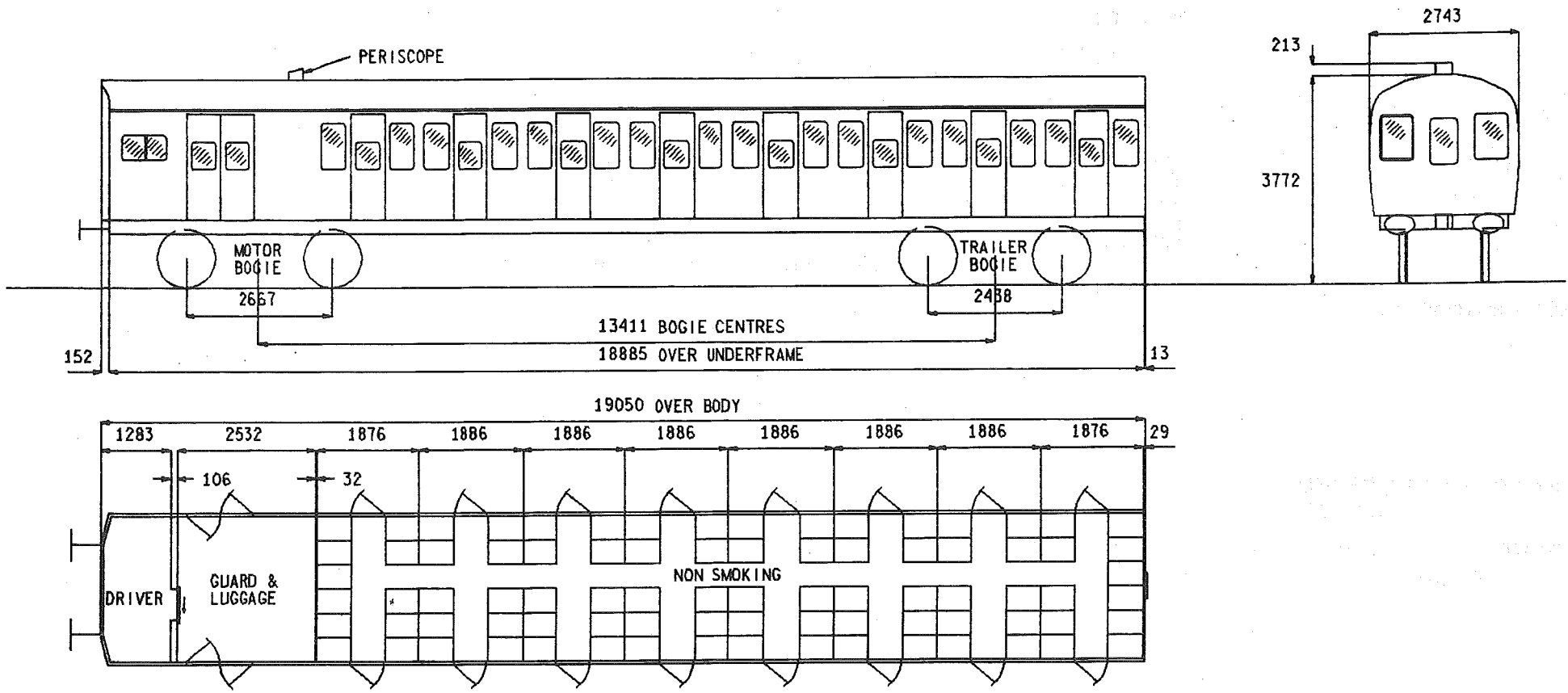

SEATS	82
TOILETS	-
COMPARTMENTS	-
GUARDS COMPARTMENTS	1
VENTILATION	-
CATERING EQUIPMENT	-

ORIGINAL DIAGRAMS FOR REFERENCE:-
S.R.2129

ISSUE 6 DATE MAR 86

EB 266

BASIC TYPE

ALTERNATIVES

BRAKES
BOGIE/SUSPENSION
BODY CONSTRUCTION
COUPLINGS
TRAIN HEATING
MAX.SPEED M.P.H.
MIN.RAD.CURVE CHAINS
LIGHTING
TARE WEIGHT TONNES
GANGWAYS
A.W.S.
TRAIN COMMUNICATION
BUFFERS

S.R.DESIGN REFERENCE CODE

ELECTRO PNEUMATIC
CENTRAL 916 MOTOR WHEEL & S.R.STANDARD 229 X 114(ONE OF EACH)
STEEL
AUTOMATIC DROPHEAD(BUCKEYE) OUTER END-3 LINK INNER END
ELECTRIC(BR)
75
3.5
TUNGSTEN
40
NOT FITTED
NOT FITTED
DRIVER/GUARD
RETRACTABLE SPINDLE-559 X 356 OVAL OUTER END-CENTRE WEARING PLATE
INNER END
CP

FITTED

CP 1A

TRACTION DATA FOR MULTIPLE UNITS

EMU- INTRODUCED-CLASS 415/1 1951-RECLASSED 415/0 1976.
VOLTAGE 750/850 VOLTS D.C.THIRD RAIL
TRACTION MOTORS 2 X 250 HP ENGLISH ELECTRIC

BASIC TYPE

EB 266 OA

VARIANTS

2A A.W.S.FITTED.
3A S.R.DESIGN REFERENCE CODE CP 1A,A.W.S.FITTED.

DRIVING MOTOR BRAKE SECOND

CLASS 415/0

DMBS

EB 267

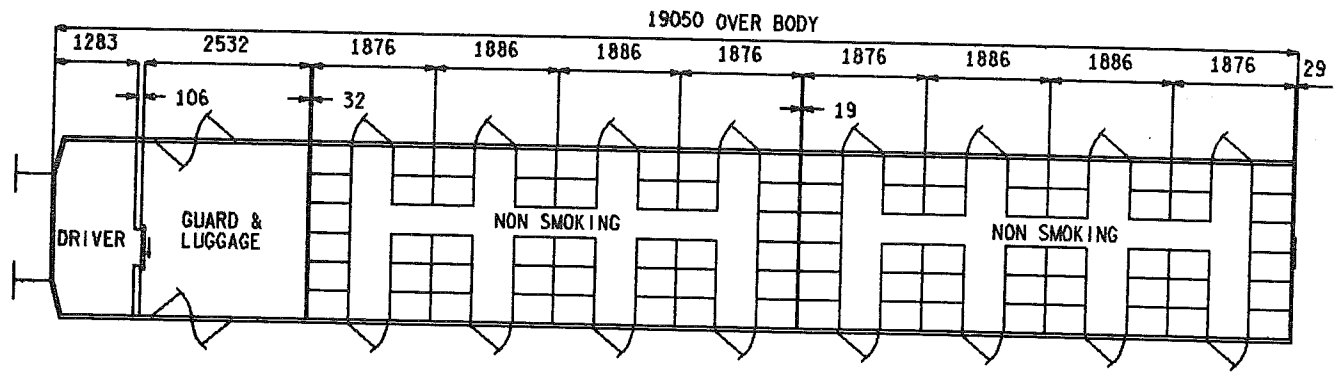
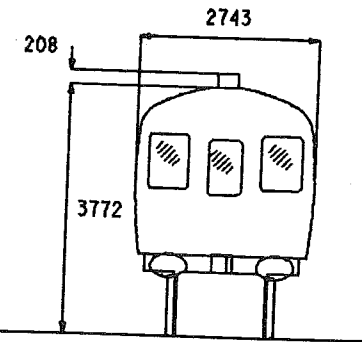
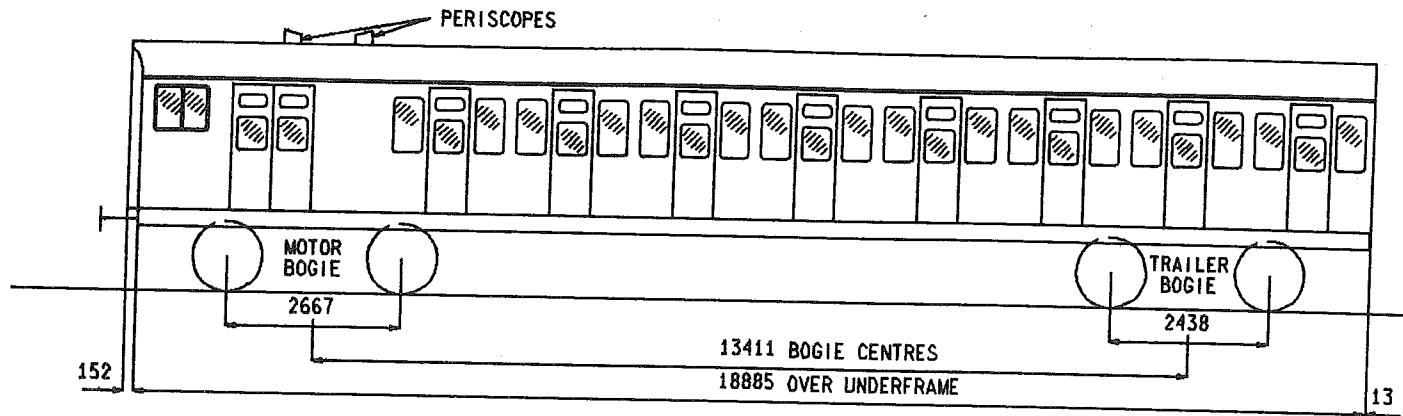

SEATS	84
TOILETS	-
COMPARTMENTS	-
GUARDS COMPARTMENTS	1
VENTILATION	-
CATERING EQUIPMENT	-

ORIGINAL DIAGRAMS FOR REFERENCE:-
S.R.2130

ISSUE 6 DATE SEPT 88

EB 267

	<u>BASIC TYPE</u>	<u>ALTERNATIVES</u>
BRAKES	ELECTRO PNEUMATIC	
BOGIE/SUSPENSION	CENTRAL 916 MOTOR WHEEL & S.R.STANDARD 229 X 114(ONE OF EACH)	
BODY CONSTRUCTION	STEEL	
COUPLINGS	AUTOMATIC DROPHEAD(BUCKEY) OUTER END-3 LINK INNER END	
TRAIN HEATING	ELECTRIC(BR)	
MAX.SPEED M.P.H.	CLASS 415/1 & 416/1 75-CLASS 418/0 90	
MIN.RAD.CURVE CHAINS	3.5	
LIGHTING	TUNGSTEN	
TARE WEIGHT TONNES	40	
GANGWAYS	NOT FITTED	
A.W.S.	NOT FITTED	FITTED
TRAIN COMMUNICATION	PUBLIC ADDRESS WITH TRANSMITTER	
BUFFERS	RETRACTABLE SPINDLE-559 X 356 OVAL OUTER END-CENTRE WEARING PLATE	
	INNER END	
S.R.DESIGN REFERENCE CODE	CP 1AE	CP 1AS

TRACTION DATA FOR MULTIPLE UNITS

EMU- INTRODUCED-CLASS 415/1 1951-CLASS 416/1 1959-CLASS 418/0 1957 AS CLASS 414/1 & RECLASSED 1976

VOLTAGE 750/850 VOLTS D.C.THIRD RAIL

TRACTION MOTORS 2 X 250 HP ENGLISH ELECTRIC

BASIC TYPE

EB 267 0B

VARIANTS

1A A.W.S.FITTED,S.R.DESIGN REFERENCE CODE 1AS.

DRIVING MOTOR BRAKE SECOND

CLASS 413/2
414/2
415/0
415/3
416/2

DMBS

EB 269

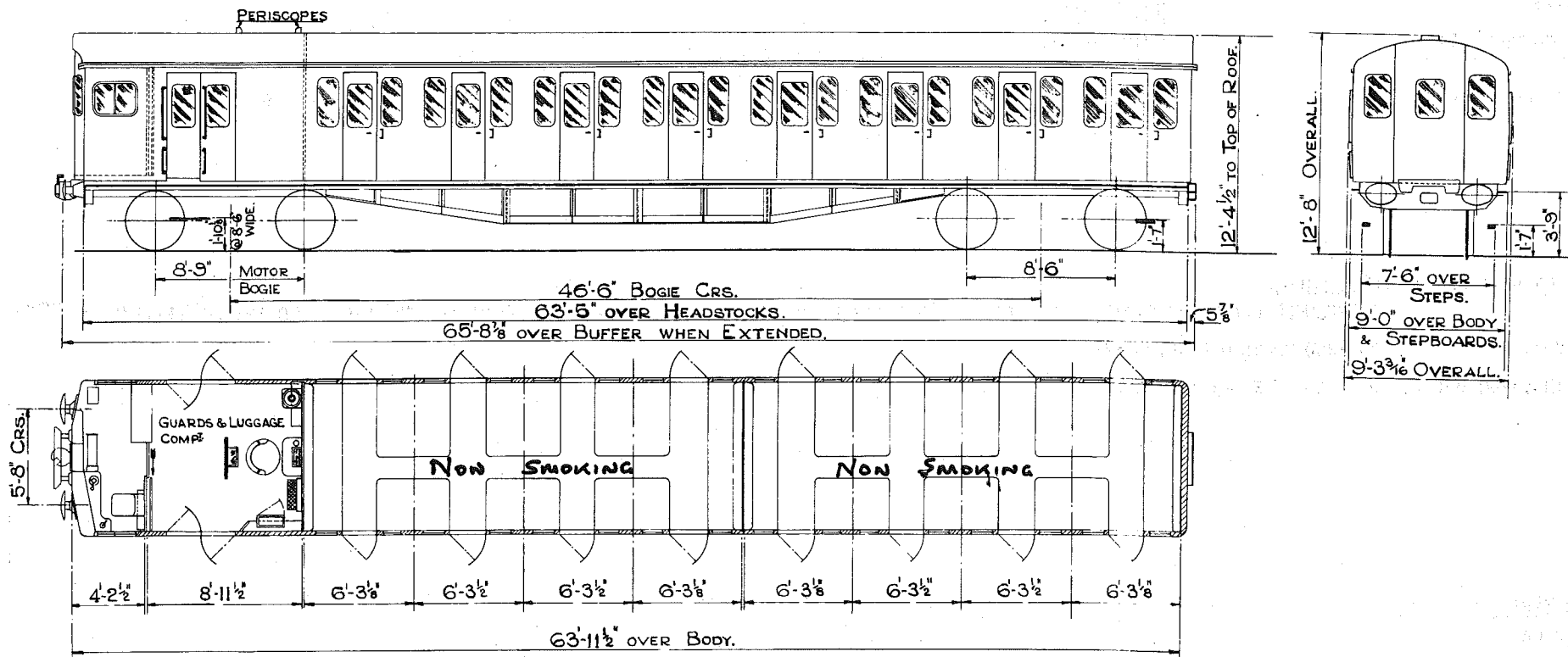

SEATS	84
TOILETS	-
COMPARTMENTS	-
GUARDS COMPARTMENTS	1
VENTILATION	-
CATERING EQUIPMENT	-

ORIGINAL DIAGRAMS FOR REFERENCE:-
BR 400

ISSUE 5 DATE NOV '84

EB 269

BRAKES
BOGIE/SUSPENSION
BODY CONSTRUCTION
COUPLINGS
TRAIN HEATING
MAX. SPEED M.P.H.
MIN. RAD. CURVE CHAINS
LIGHTING
TARE WEIGHT TONNES
GANGWAYS
A.W.S.
TRAIN COMMUNICATION
BUFFERS
S.R. DESIGN REFERENCE CODE

BASIC TYPE

ELECTRO PNEUMATIC
S.R.MK 3D POWERED & UNPOWERED(ONE OF EACH)
STEEL
AUTOMATIC DROPHEAD(BUCKEYE) OUTER END-3 LINK INNER END
ELECTRIC(BR)
CLASS 415/1,415/2,416/2 75-CLASS 414/2,418/1 90
3.5
TUNGSTEN
42
NOT FITTED
NOT FITTED
DRIVER/GUARD
RETRACTABLE SPINDLE-559 X 356 OVAL OUTER END-CENTRE WEARING PLATE
INNER END
CO

ALTERNATIVES

S.R.MK 4 POWERED & UNPOWERED(ONE OF EACH)

FITTED

CO 1A, CO 2B, CO 3A

TRACTION DATA FOR MULTIPLE UNITS

EMU- INTRODUCED-CLASS 414/2,415/2 1957 -CLASS 415/1,418/1 1951-CLASS 416/2 1954,413/2 AS 414/2 1957 RECLASSED 1983,415 RECLASSED 1984.
VOLTAGE 750/850 VOLTS D.C. THIRD RAIL
TRACTION MOTORS 2 X 250 HP ENGLISH ELECTRIC

BASIC TYPE

EB 269 0A

VARIANTS

1A S.R. DESIGN REFERENCE CODE CO 1A.
2B S.R. DESIGN REFERENCE CODE CO 2B, S.R.MK 4 POWERED & UNPOWERED BOGIES(ONE OF EACH).
3B S.R. DESIGN REFERENCE CODE CO 3A, S.R.MK 4 POWERED & UNPOWERED BOGIES(ONE OF EACH).
4A A.W.S. FITTED.
5A S.R. DESIGN REFERENCE CODE CO 1A, A.W.S. FITTED.
6B S.R. DESIGN REFERENCE CODE CO 3A, S.R.MK 4 POWERED & UNPOWERED BOGIES(ONE OF EACH), A.W.S. FITTED.

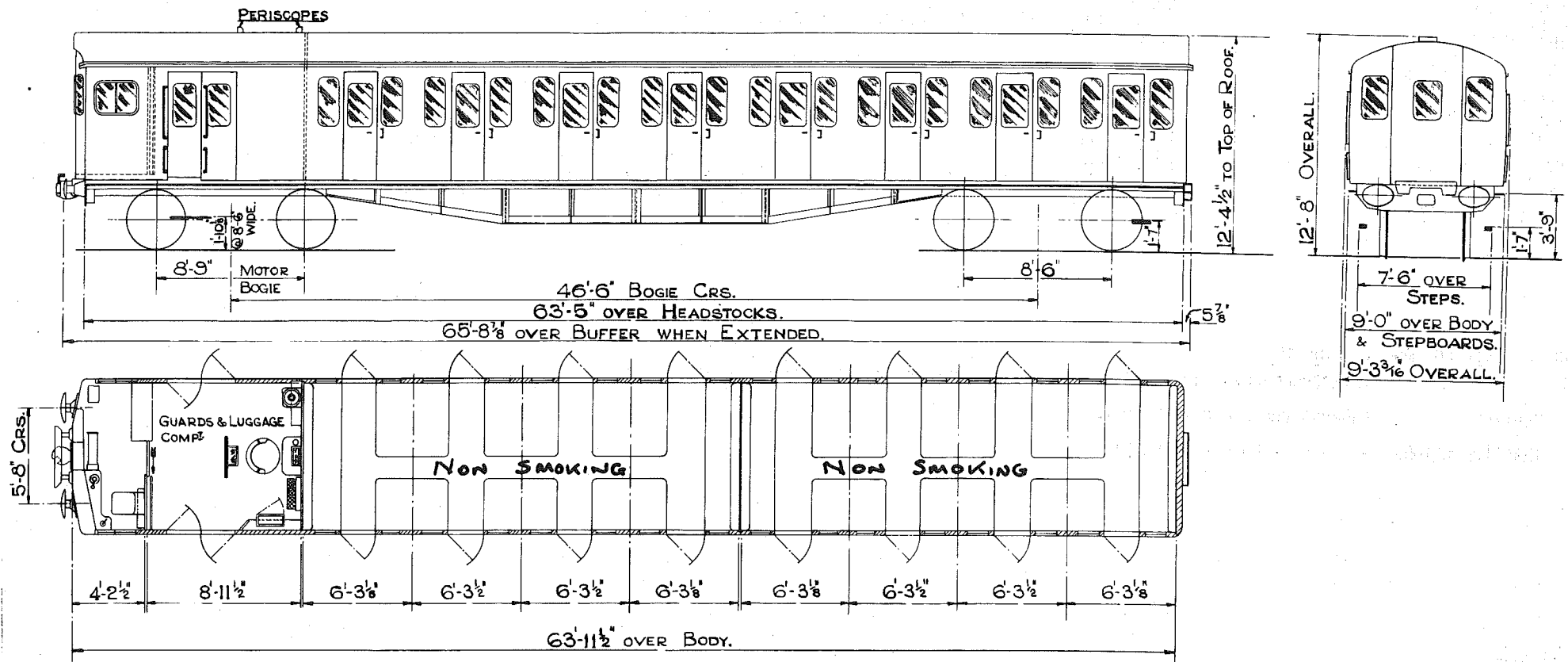

SEATS	84
TOILETS	-
COMPARTMENTS	-
GUARDS COMPARTMENTS	1
VENTILATION	-
CATERING EQUIPMENT	-

ORIGINAL DIAGRAMS FOR REFERENCE:-
BR 400

ISSUE 5 DATE NOV '84

EB 270

BASIC TYPE

ALTERNATIVES

BRAKES
BOGIE/SUSPENSION

ELECTRO PNEUMATIC
S.R.MK 4 POWERED & UNPOWERED(ONE OF EACH)

S.R.MK 3B POWERED & COMMONWEALTH UNPOWERED(ONE OF EACH),S.R.MK 4 POWERED & COMMONWEALTH UNPOWERED (ONE OF EACH)

BODY CONSTRUCTION
COUPLINGS
TRAIN HEATING
MAX.SPEED M.P.H.
MIN.RAD.CURVE CHAINS
LIGHTING
TARE WEIGHT TONNES
GANGWAYS
A.W.S.
TRAIN COMMUNICATION
BUFFERS

STEEL
AUTOMATIC DROPHEAD(BUCKEYE)OUTER END-3 LINK INNER END
ELECTRIC(BR)
90
3.5
TUNGSTEN
42
NOT FITTED
NOT FITTED
DRIVER/GUARD
RETRACTABLE SPINDLE-559 X 356 OVAL OUTER END-CENTRE WEARING PLATE
INNER END
CR

FITTED

CU,CU 1A

S.R.DESIGN REFERENCE CODE

TRACTION DATA FOR MULTIPLE UNITS

EMU- INTRODUCED-CLASS 414/3 1957-CLASS 413/3 AS CLASS 414/3 1957 & RECLASSED 1983.
VOLTAGE 750/850 VOLTS D.C.THIRD RAIL
TRACTION MOTORS 2 X 250 HP ENGLISH ELECTRIC

BASIC TYPE

EB 270 0A

VARIANTS

1B S.R.MK 3B POWERED & COMMONWEALTH UNPOWERED BOGIES(ONE OF EACH),S.R.DESIGN REFERENCE CODE CU,A.W.S.FITTED.
2C S.R.MK 4 POWERED & COMMONWEALTH UNPOWERED BOGIES(ONE OF EACH),S.R.DESIGN REFERENCE CODE CU 1A,A.W.S.FITTED.
3A A.W.S.FITTED.

DRIVING MOTOR BRAKE SECOND

CLASS 414/3
415/3

DMBS

EB 271

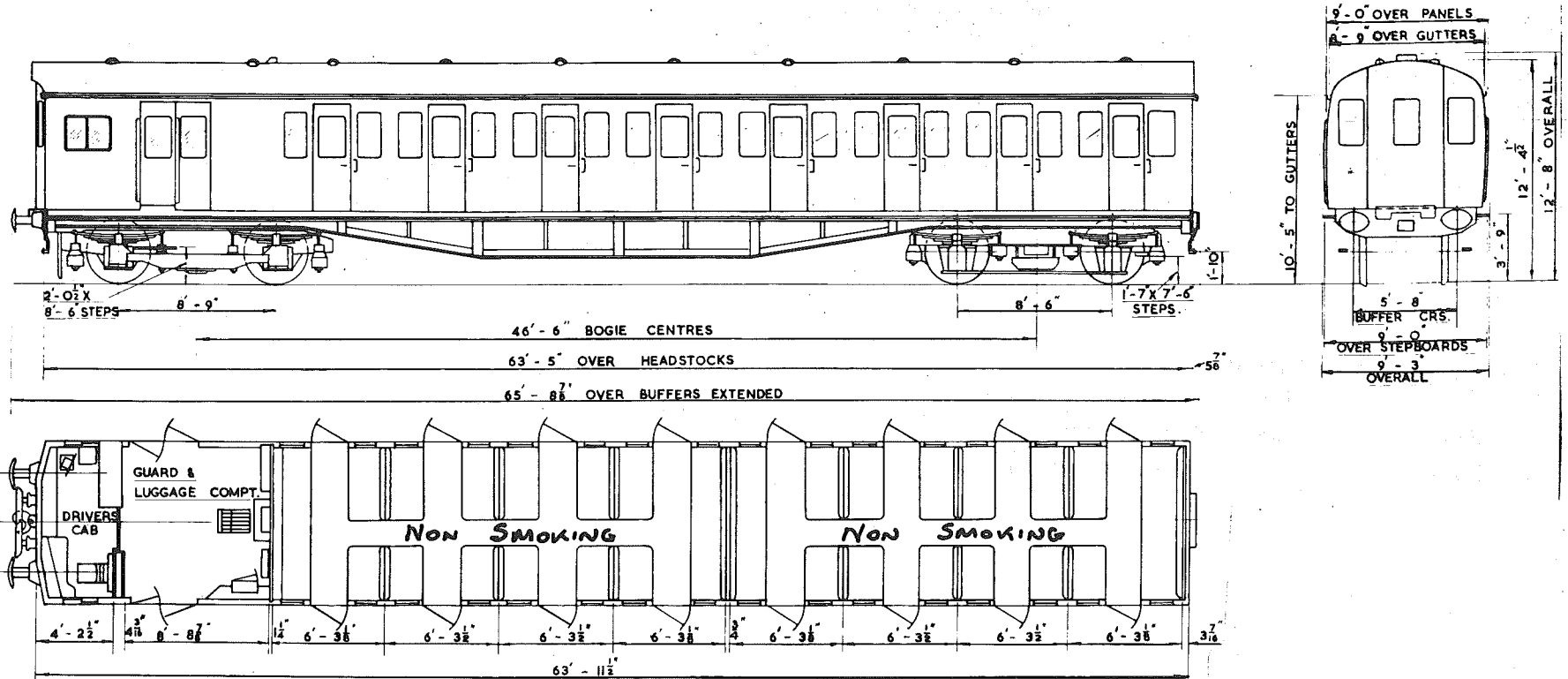

SEATS	84
TOILETS	-
COMPARTMENTS	-
GUARDS COMPARTMENTS	1
VENTILATION	-
CATERING EQUIPMENT	-

ORIGINAL DIAGRAMS FOR REFERENCE:-
BR 414

ISSUE 8 DATE MAR 86

EB 271

BRAKES
BOGIE/SUSPENSIONBODY CONSTRUCTION
COUPLINGS
TRAIN HEATING
MAX.SPEED M.P.H.
MIN.RAD.CURVE CHAINS
LIGHTING
TARE WEIGHT TONNES
GANGWAYS
A.W.S.
TRAIN COMMUNICATION
BUFFERS

S.R.DESIGN REFERENCE CODE
BEARINGSBASIC TYPEELECTRO PNEUMATIC
S.R.MK 3D POWERED & UNPOWERED(ONE OF EACH)STEEL
AUTOMATIC DROPHEAD(BUCKEYE) OUTER END-3 LINK INNER END
ELECTRIC(BR)
CLASS 414/3 90-CLASS 415/2 75
3.5
TUNGSTEN
41
NOT FITTED
NOT FITTED
DRIVER/GUARD
RETRACTABLE SPINDLE-559 X 356 OVAL OUTER END-CENTRE WEARING PLATE
INNER END
CS S
OILALTERNATIVESELECTRO PNEUMATIC-LAYCOCK KNORR EQUIPMENT
S.R.MK 3D POWERED & S.R.MK 3C UNPOWERED(ONE OF EACH),S.R.MK 3C POWERED & UNPOWERED(ONE OF EACH),S.R.MK 4 POWERED & COMMONWEALTH UNPOWERED(ONE OF EACH).

FITTED

CS E,CS 1AS
ROLLERTRACTION DATA FOR MULTIPLE UNITSEMU- INTRODUCED 1957, 415/2 RECLASSED 1984.

VOLTAGE 750/850 VOLTS D.C.THIRD RAIL

TRACTION MOTORS 2 X 250 HP ENGLISH ELECTRICBASIC TYPE

EB 271 OA

VARIANTSOB S.R.DESIGN REFERENCE CODE CS E.
OC S.R.DESIGN REFERENCE CODE CS E,S.R.MK 3D POWERED & S.R.MK 3C UNPOWERED BOGIES(ONE OF EACH).
OD S.R.MK 3C POWERED & UNPOWERED BOGIES(ONE OF EACH).
OE S.R.MK 3C POWERED & UNPOWERED BOGIES(ONE OF EACH),ROLLER BEARINGS.
OF S.R.DESIGN REFERENCE CODE CS E,S.R.MK 4 POWERED & COMMONWEALTH BOGIES(ONE OF EACH),ROLLER BEARINGS.
1D S.R.DESIGN REFERENCE CODE CS 1AS,S.R.MK 3C POWERED & UNPOWERED BOGIES(ONE OF EACH),A.W.S.FITTED.
1E S.R.DESIGN REFERENCE CODE CS 1AS,S.R.MK 3C POWERED & UNPOWERED BOGIES(ONE OF EACH),ROLLER BEARINGS,A.W.S.FITTED.
1G S.R.DESIGN REFERENCE CODE CS 1AS,S.R.MK 3C POWERED & UNPOWERED BOGIES(ONE OF EACH),ELECTRO PNEUMATIC BRAKES WITH LAYCOCK KNORR EQUIPMENT,A.W.S.FITTED.
1H S.R.DESIGN REFERENCE CODE CS 1AS,S.R.MK 3C POWERED & UNPOWERED BOGIES(ONE OF EACH),ELECTRO PNEUMATIC BRAKES WITH LAYCOCK KNORR EQUIPMENT,A.W.S.FITTED,ROLLER BEARINGS.
2A A.W.S.FITTED.
2B S.R.DESIGN REFERENCE CODE CS E,A.W.S.FITTED.
2D S.R.MK 3C POWERED & UNPOWERED BOGIES(ONE OF EACH),A.W.S.FITTED.

DRIVING MOTOR BRAKE SECOND

CLASS 415/3

DMBS

EB 272

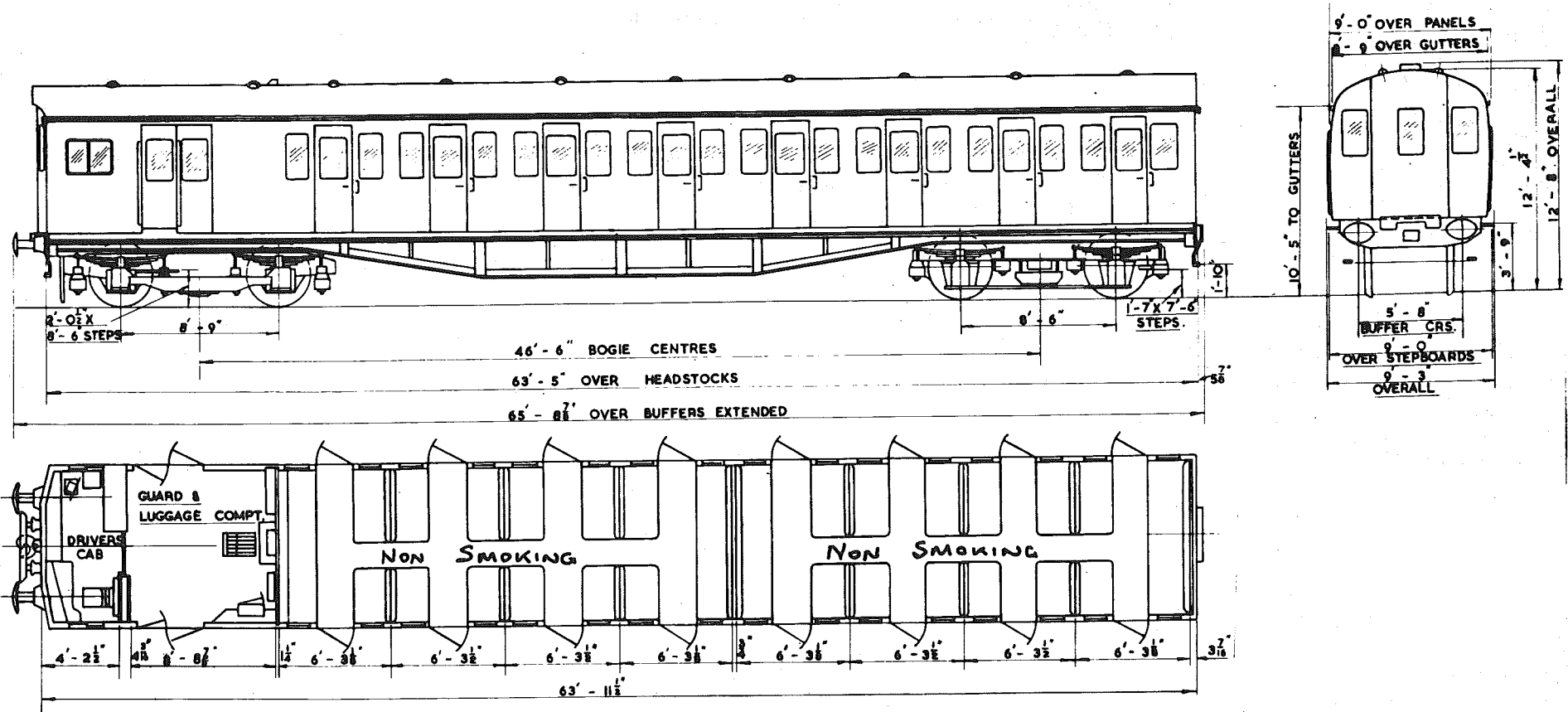

SEATS	84
TOILETS	-
COMPARTMENTS	-
GUARDS COMPARTMENTS	1
VENTILATION	-
CATERING EQUIPMENT	-

ORIGINAL DIAGRAMS FOR REFERENCE:-
BR 414

ISSUE 7 DATE MAR 86

BASIC TYPE

BRAKES
BOGIE/SUSPENSION

ELECTRO PNEUMATIC
S.R.MK 3D POWERED & UNPOWERED(ONE OF EACH)

BODY CONSTRUCTION
COUPLINGS
TRAIN HEATING
MAX.SPEED M.P.H.
MIN.RAD.CURVE CHAINS
LIGHTING
TARE WEIGHT TONNES
GANGWAYS
A.W.S.
TRAIN COMMUNICATION
BUFFERS

STEEL
AUTOMATIC DROPHEAD(BUCKEYE) OUTER END-3 LINK INNER END
ELECTRIC(BR)
75
3.5
TUNGSTEN
41
NOT FITTED
NOT FITTED
DRIVER/GUARD
RETRACTABLE SPINDLE-559 X 356 OVAL OUTER END-CENTRE WEARING PLATE
INNER END
CT S
OIL

S.R.DESIGN REFERENCE CODE
BEARINGS

ALTERNATIVES

ELECTRO PNEUMATIC-LAYCOCK KNORR EQUIPMENT
S.R.MK 3D POWERED & S.R.MK 3C UNPOWERED(ONE OF EACH),S.R.MK 3C POWERED & UNPOWERED(ONE OF EACH),S.R.MK 4 POWERED & COMMONWEALTH UNPOWERED BOGIES (ONE OF EACH).

FITTED

CT E,CT 1AS
ROLLER

TRACTION DATA FOR MULTIPLE UNITS

EMU- INTRODUCED 1957,RECLASSED 1984.
VOLTAGE 750/850 VOLTS D.C.THIRD RAIL
TRACTION MOTORS 2 X 250 HP ENGLISH ELECTRIC

BASIC TYPE

EB 272 0A

VARIANTS

- 0B S.R.DESIGN REFERENCE CODE CT E.
- 0C S.R.DESIGN REFERENCE CODE CT E,S.R.MK 3D POWERED & S.R.MK 3C UNPOWERED BOGIES(ONE OF EACH).
- 0D S.R.MK 3C POWERED & UNPOWERED BOGIES (ONE OF EACH).
- 0E S.R.MK 3C POWERED & UNPOWERED BOGIES(ONE OF EACH),ROLLER BEARINGS.
- 1D S.R.DESIGN REFERENCE CODE CT 1AS,S.R.MK 3C POWERED & UNPOWERED BOGIES(ONE OF EACH),A.W.S.FITTED.
- 1E S.R.DESIGN REFERENCE CODE CT 1AS,S.R.MK 3C POWERED & UNPOWERED BOGIES(ONE OF EACH),ROLLER BEARINGS,A.W.S.FITTED.
- 1G S.R.DESIGN REFERENCE CODE CT 1AS,S.R.MK 3C POWERED & UNPOWERED BOGIES(ONE OF EACH),ELECTRO PNEUMATIC BRAKES WITH LAYCOCK KNORR EQUIPMENT,A.W.S.FITTED.
- 2A A.W.S.FITTED.
- 2B S.R.DESIGN REFERENCE CODE CT E,A.W.S.FITTED.
- 2D S.R.MK 3C POWERED & UNPOWERED (ONE OF EACH),A.W.S.FITTED.
- 2F S.R.MK 4 POWERED & COMMONWEALTH UNPOWERED BOGIES (ONE OF EACH) ELECTRO PNEUMATIC BRAKE WITH LAYCOCK KNORR EQUIPMENT,ROLLER BEARINGS,A.W.S.FITTED.

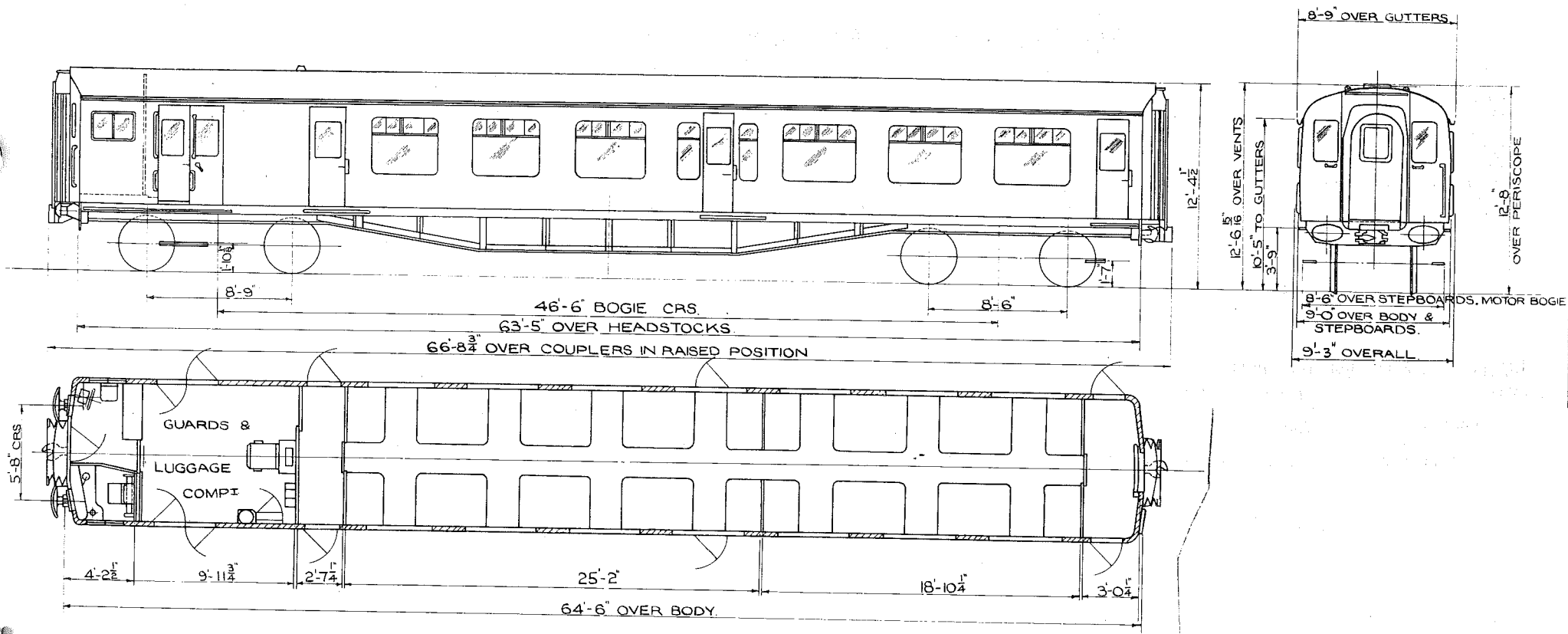

SEATS	56
TOILETS	-
COMPARTMENTS	-
GUARDS COMPARTMENTS	1
VENTILATION	-
CATERING EQUIPMENT	-

ORIGINAL DIAGRAMS FOR REFERENCE:-
BR 402

ISSUE DATE
3 JAN 84

EB 273

BRAKES
BOGIE/SUSPENSION
BODY CONSTRUCTION
COUPLINGS
TRAIN HEATING
MAX.SPEED M.P.H.
MIN.RAD.CURVE CHAINS
LIGHTING
TARE WEIGHT TONNES
GANGWAYS
A.W.S.
TRAIN COMMUNICATION
BUFFERS
S.R.DESIGN REFERENCE CODE
BEARINGS

BASIC TYPE

ELECTRO PNEUMATIC
S.R.MK 4 POWERED & UNPOWERED(ONE OF EACH)
STEEL
AUTOMATIC DROPHEAD(BUCKEYE) OUTER END-AUTOMATIC SOLID SHANK
(ALLIANCE NO.2) INNER END
ELECTRIC(BR)
90
3.5
TUNGSTEN
41
EXPRESS ELECTRIC
NOT FITTED
DRIVER/GUARD
RETRACTABLE SPINDLE-559 X 356 OVAL-OUTER END ONLY
AB
OIL

ALTERNATIVES

S.R.MK 4 POWERED & COMMONWEALTH UNPOWERED(ONE OF EACH)

ROLLER

TRACTION DATA FOR MULTIPLE UNITS

EMU- INTRODUCED 1956
VOLTAGE 750/850 VOLTS D.C.THIRD RAIL
TRACTION MOTORS 2 X 250 HP ENGLISH ELECTRIC

BASIC TYPE

EB 273 OA

VARIANTS

OB ROLLER BEARINGS.
OC S.R.MK 4 POWERED & COMMONWEALTH BOGIES(ONE OF EACH), ROLLER BEARINGS.

DRIVING MOTOR BRAKE SECOND

CLASS 410/2
411/2

DMBS

EB 274

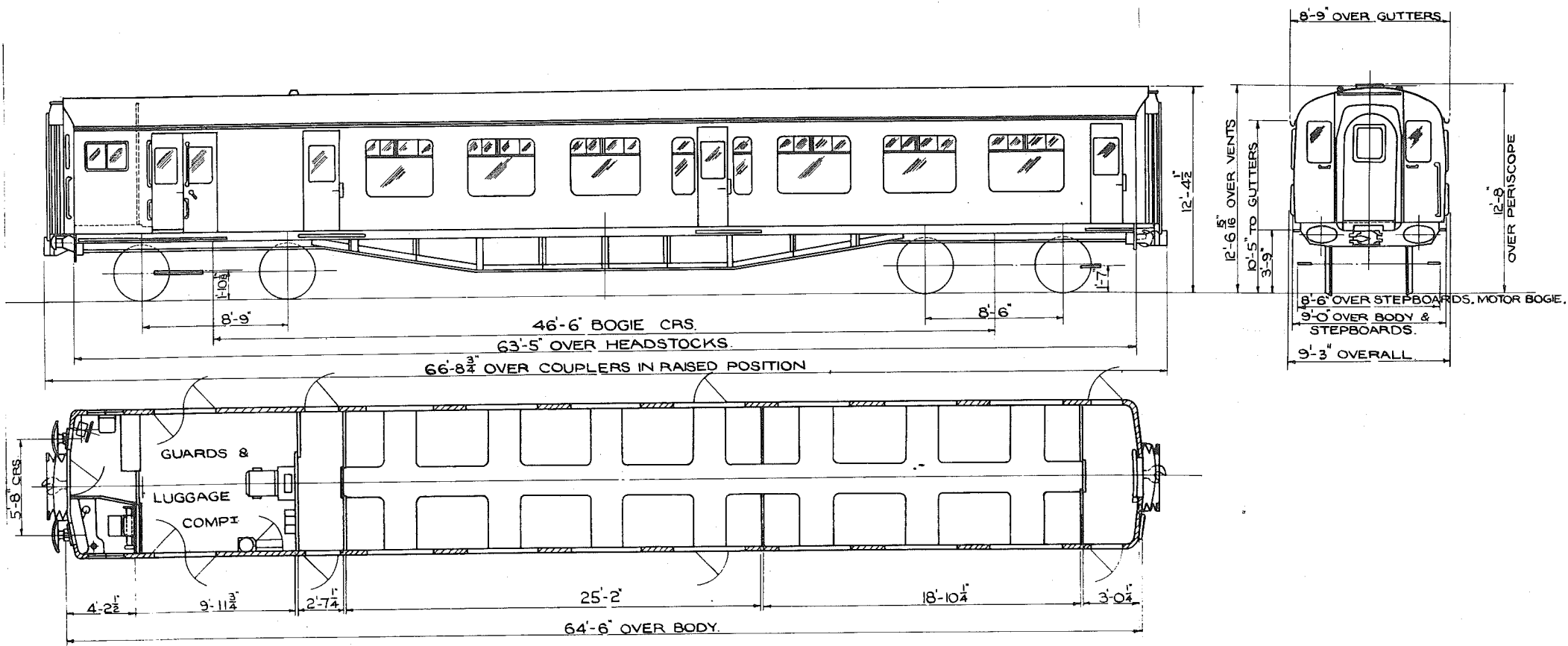

SEATS	56
TOILETS	-
COMPARTMENTS	-
GUARDS COMPARTMENTS	1
VENTILATION	-
CATERING EQUIPMENT	-

ORIGINAL DIAGRAMS FOR REFERENCE:-
BR 402

ISSUE 3 DATE MAR 86

EB 274

BASIC TYPE

BRAKES
BOGIE/SUSPENSION
BODY CONSTRUCTION
COUPLINGS

TRAIN HEATING
MAX.SPEED M.P.H.
MIN.RAD.CURVE CHAINS
LIGHTING
TARE WEIGHT TONNES
GANGWAYS
A.W.S.
TRAIN COMMUNICATION
BUFFERS
S.R.DESIGN REFERENCE CODE

ELECTRO PNEUMATIC
S.R.MK 4 POWERED & COMMONWEALTH UNPOWERED(ONE OF EACH)
STEEL
AUTOMATIC DROPHEAD(BUCKEYE) OUTER END-AUTOMATIC SOLID SHANK
(ALLIANCE NO.2) INNER END
ELECTRIC(BR)
90
3.5
TUNGSTEN
41
EXPRESS ELECTRIC
NOT FITTED
DRIVER/GUARD
RETRACTABLE SPINDLE-559X356 OVAL - OUTER END ONLY
AG

ALTERNATIVES

TRACTION DATA FOR MULTIPLE UNITS

EMU- INTRODUCED - CLASS 410/2 1959-CLASS 411-2 1958.
VOLTAGE 750/850 VOLTS D.C.THIRD RAIL.
TRACTION MOTORS 2 X 250 HP ENGLISH ELECTRIC.

BASIC TYPE

EB 274 1B

VARIANTS

NONE

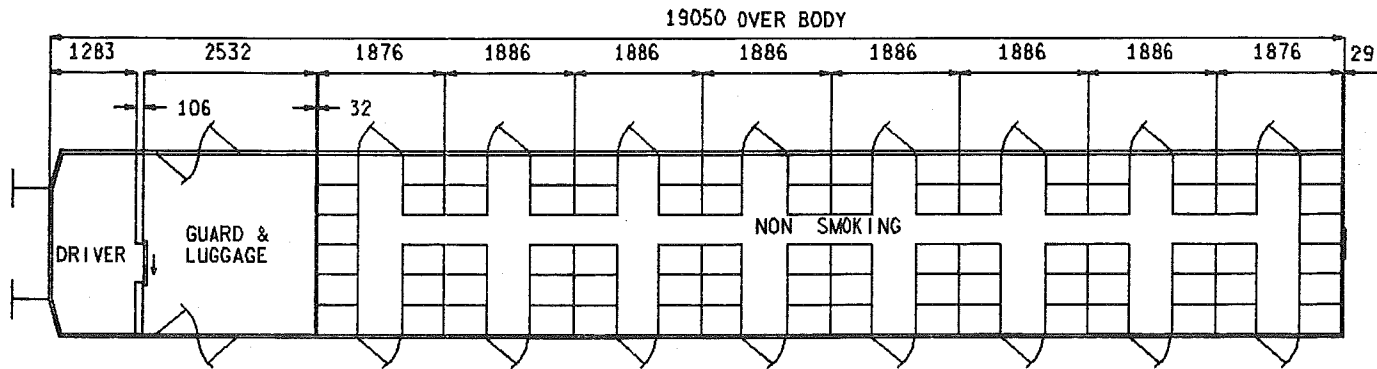
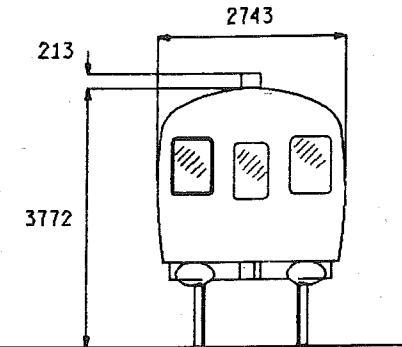
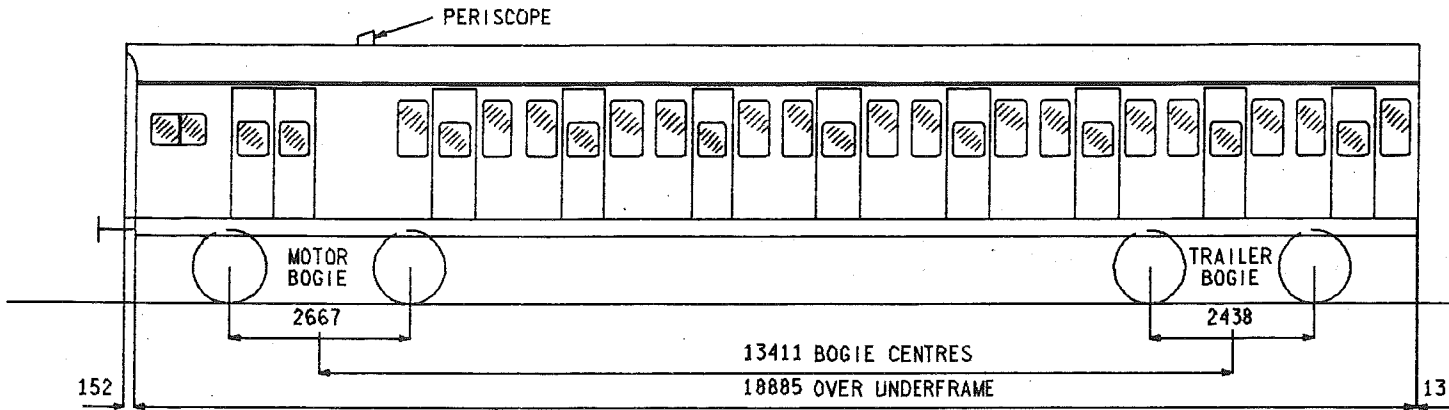

SEATS	82
TOILETS	-
COMPARTMENTS	-
GUARDS COMPARTMENTS	1
VENTILATION	-
CATERING EQUIPMENT	-

ORIGINAL DIAGRAMS FOR REFERENCE:-
S.R. 2129

ISSUE DATE
5 MAR 86

EB 277

BASIC TYPE

BRAKES
BOGIE/SUSPENSION
BODY CONSTRUCTION
COUPLINGS
TRAIN HEATING
MAX.SPEED M.P.H.
MIN.RAD.CURVE CHAINS
LIGHTING
TARE WEIGHT TONNES
GANGWAYS
A.W.S.
TRAIN COMMUNICATION
BUFFERS
S.R.DESIGN REFERENCE CODE

ELECTRO PNEUMATIC
CENTRAL 1016 MOTOR WHEEL & S.R.STANDARD 229 X 114(ONE OF EACH)
STEEL
AUTOMATIC DROPHEAD(BUCKEYE) OUTER END-THREE LINK INNER END
ELECTRIC(BR)
75
3.5
FLUORESCENT & TUNGSTEN
40
NOT FITTED
NOT FITTED
DRIVER/GUARD-PUBLIC ADDRESS WITH TRANSMITTER
RETRACTABLE SPINDLE(559 X 356 OVAL) OUTER END-CENTRE WEARING PLATE
INNER END
CX

ALTERNATIVES

TRACTION DATA FOR MULTIPLE UNITS

EMU- INTRODUCED 1951-REFURBISHED 1979/80, RECLASSIFIED 1984.
VOLTAGE 750/850 VOLTS D.C. THIRD RAIL
TRACTION MOTORS 2 X 250 HP ENGLISH ELECTRIC

BASIC TYPE

EB 277 OA-REFURBISHED

VARIANTS

NONE

DRIVING MOTOR BRAKE SECOND

CLASS 415/4
416/3

DMBS

EB 278

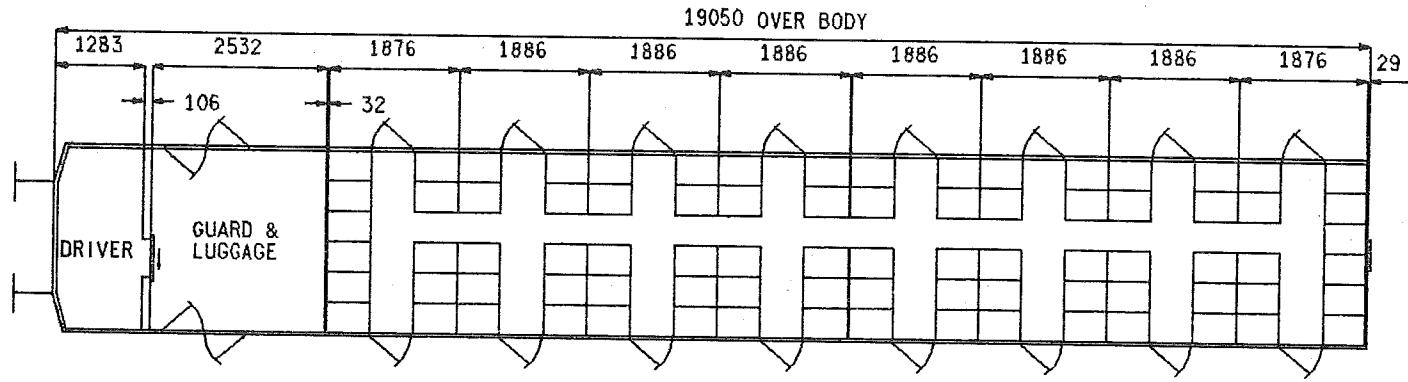
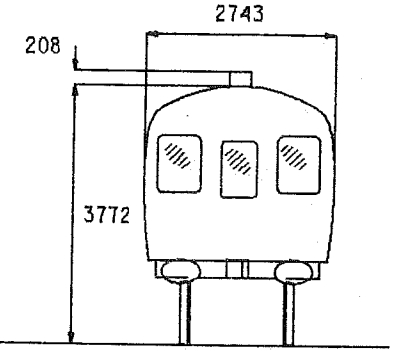
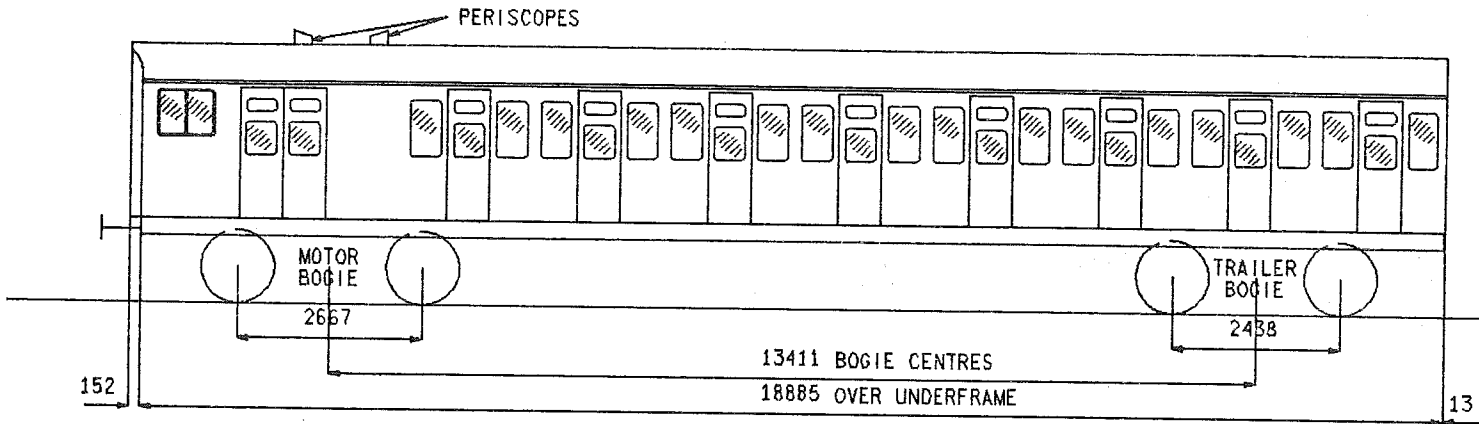

SEATS	82
TOILETS	-
COMPARTMENTS	-
GUARDS COMPARTMENTS	1
VENTILATION	-
CATERING EQUIPMENT	-

ISSUE 4 DATE JAN '84

EB 278

BASIC TYPE

BRAKES
BOGIE/SUSPENSION
BODY CONSTRUCTION
COUPLINGS
TRAIN HEATING
MAX.SPEED M.P.H.
MIN.RAD.CURVE CHAINS
LIGHTING
TARE WEIGHT TONNES
GANGWAYS
A.W.S.
TRAIN COMMUNICATION
BUFFERS
S.R.DESIGN REFERENCE CODE

ELECTRO PNEUMATIC
CENTRAL 916 MOTOR WHEEL & SR STANDARD 229X114(ONE OF EACH)
STEEL
AUTOMATIC DROPHEAD(BUCKEYE) OUTER END-3 LINK INNER END
ELECTRIC(BR)
75
3.5
FLUORESCENT & TUNGSTEN
40
NOT FITTED
FITTED
DRIVER/GUARD & PUBLIC ADDRESS WITH TRANSMITTER
RETRACTABLE SPINDLE-559X356 OVAL- OUTER END-CENTRE WEARING PLATE
INNER END
CX 1A

ALTERNATIVES

CP 1AE, CP 2AE

TRACTION DATA FOR MULTIPLE UNITS

EMU- INTRODUCED 1951, REFURBISHED 1980/81, RECLASSED 1984.
VOLTAGE 750/850 VOLTS D.C. THIRD RAIL
TRACTION MOTORS 2 X 250 HP ENGLISH ELECTRIC

BASIC TYPE

EB 278 0A

VARIANTS

1B S.R.DESIGN REFERENCE CODE CP 1AE.
2B S.R.DESIGN REFERENCE CODE CP 2AE.

DRIVING MOTOR BRAKE SECOND

CLASS 416/2

DMBS

EB 279

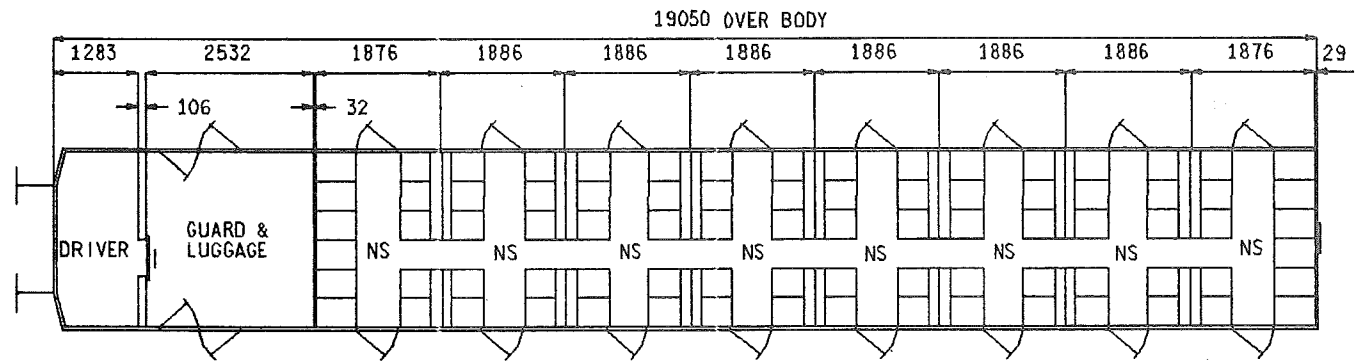
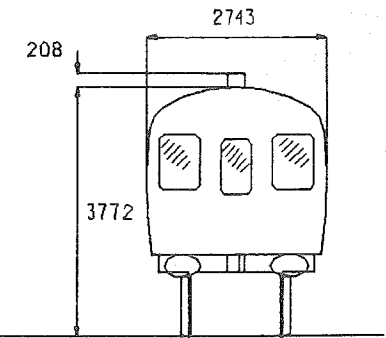
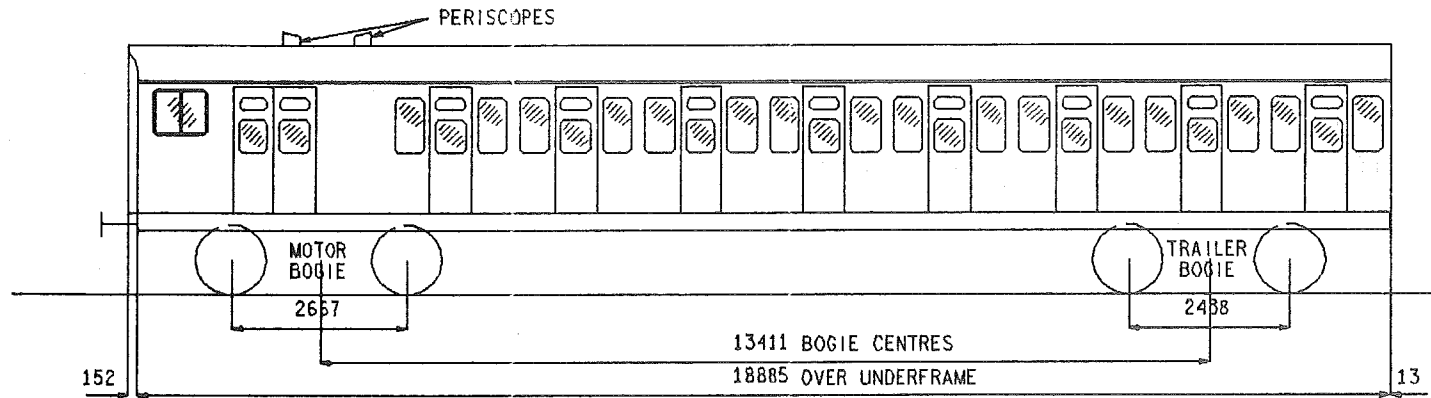

SEATS	82
TOILETS	-
COMPARTMENTS	-
GUARDS COMPARTMENTS	1
VENTILATION	-
CATERING EQUIPMENT	-

ISSUE 2 DATE NOV '84

EB 279

BASIC TYPE

BRAKES
BOGIE/SUSPENSION
BODY CONSTRUCTION
COUPLINGS
TRAIN HEATING
MAX.SPEED M.P.H.
MIN.RAD.CURVE CHAINS
LIGHTING
TARE WEIGHT TONNES
GANGWAYS
A.W.S.
TRAIN COMMUNICATION
BUFFERS

S.R.DESIGN REFERENCE CODE

ELECTRO PNEUMATIC
SR MK 3D POWERED & UNPOWERED(ONE OF EACH)
STEEL
AUTOMATIC DROPHEAD(BUCKEYE) OUTER END-3 LINK INNER END
ELECTRIC(BR)
75
3.5
FLUORESCENT & TUNGSTEN
40.5
NOT FITTED
FITTED
DRIVER/GUARD & PUBLIC ADDRESS WITH TRANSMITTER
RETRACTABLE SPINDLE-559X356 OVAL- OUTER END-CENTRE WEARING PLATE
INNER END

ALTERNATIVES

TRACTION DATA FOR MULTIPLE UNITS

EMU- INTRODUCED 1953, REFURBISHED 1980/81
VOLTAGE 750/850 VOLTS D.C. THIRD RAIL
TRACTION MOTORS 2 X 250 HP ENGLISH ELECTRIC

BASIC TYPE

EB 279 0A

VARIANTS

NONE

DRIVING MOTOR BRAKE SECOND

CLASS 416/4

DMBS

EB 280

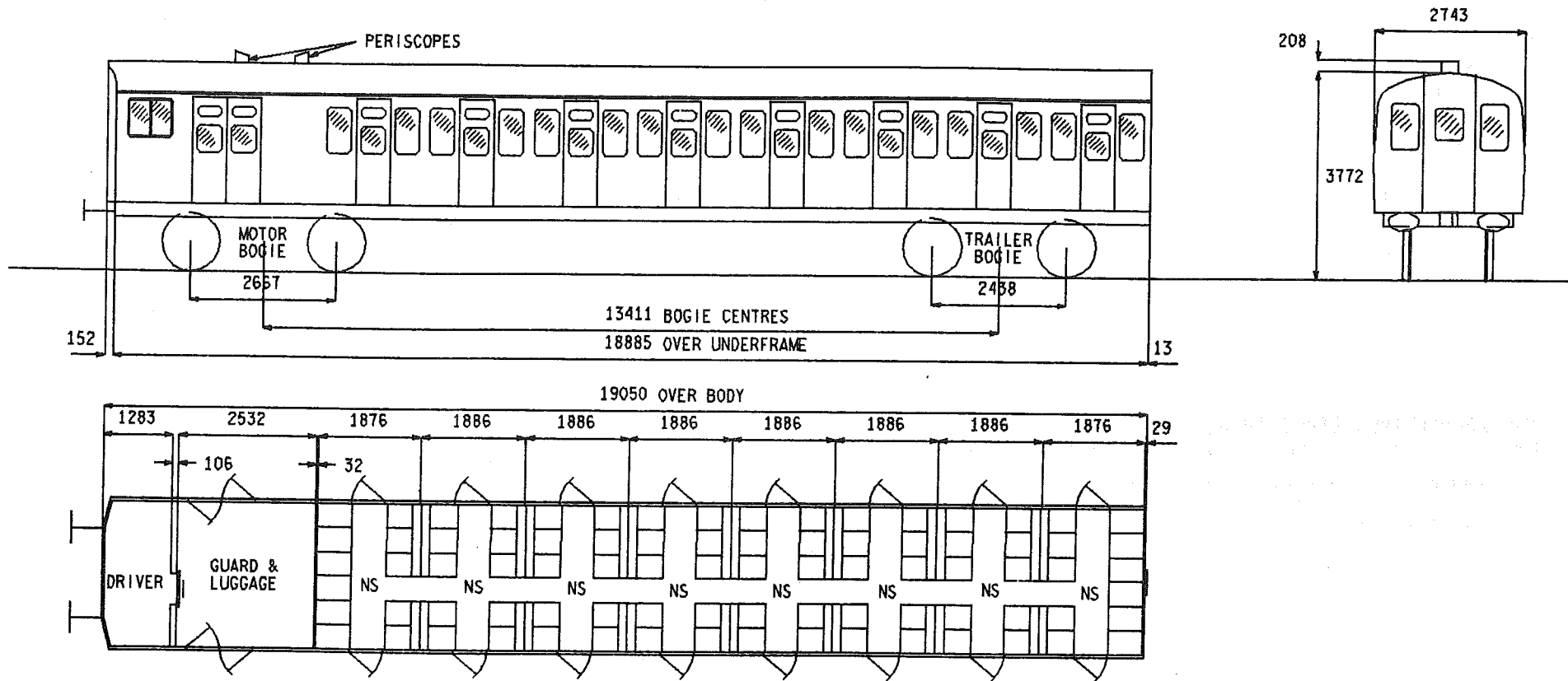

SEATS	82
TOILETS	-
COMPARTMENTS	-
GUARDS COMPARTMENTS	1
VENTILATION	-
CATERING EQUIPMENT	-

ISSUE DATE
 4 OCT '88

EB 280

BRAKES
BOGIE/SUSPENSION
BODY CONSTRUCTION
COUPLINGS
TRAIN HEATING
MAX.SPEED M.P.H.
MIN.RAD.CURVE CHAINS
LIGHTING
TARE WEIGHT TONNES
GANGWAYS
A.W.S.
TRAIN COMMUNICATION
BUFFERS
S.R.DESIGN REFERENCE CODE

BASIC TYPE

ELECTRO PNEUMATIC
SR MK 3D POWERED & UNPOWERED(ONE OF EACH)
STEEL
AUTOMATIC DROPHEAD(BUCKEYE) OUTER END-3 LINK INNER END
ELECTRIC(BR)
75
3.5
FLUORESCENT & TUNGSTEN
42
NOT FITTED
FITTED
DRIVER/GUARD & PUBLIC ADDRESS WITH TRANSMITTER
RETRACTABLE SPINDLE-559X356 OVAL- OUTER END-CENTRE WEARING PLATE
INNER END
CY

ALTERNATIVES

SR MK 4 POWERED & UNPOWERED(ONE OF EACH)

CY 2A

TRACTION DATA FOR MULTIPLE UNITS

EMU- INTRODUCED 1954, REFURBISHED 1980/81
VOLTAGE 750/850 VOLTS D.C. THIRD RAIL
TRACTION MOTORS 2 X 250 HP ENGLISH ELECTRIC

BASIC TYPE

EB 280 0A

VARIANTS

1B SR DESIGN REF.CODE CY 2A, SR MK 4 POWERED & UNPOWERED BOGIES(ONE OF EACH).

DRIVING MOTOR BRAKE STANDARD

CLASS 416/4

DMBS

EB 281

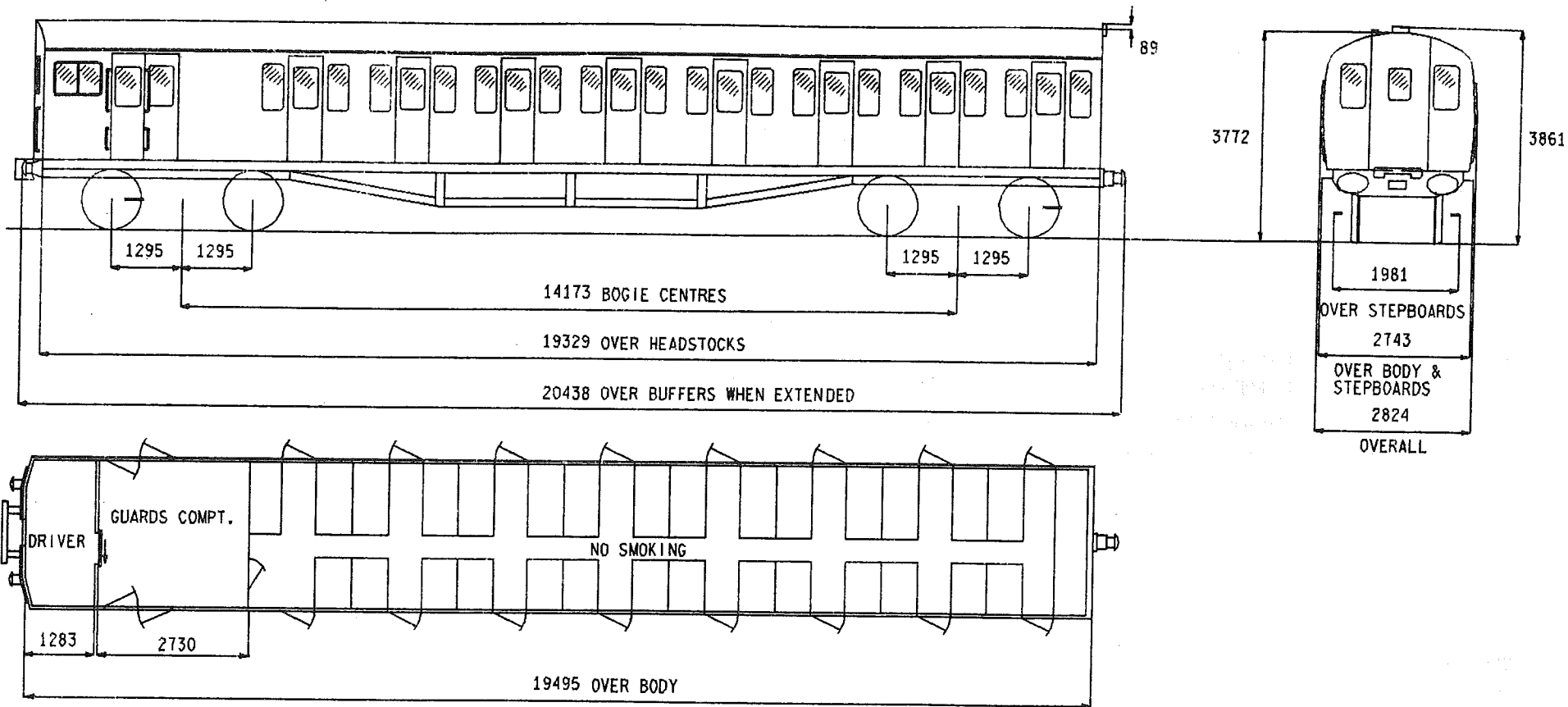

SEATS	79
TOILETS	-
COMPARTMENTS	-
GUARDS COMPARTMENTS	1
VENTILATION	-
CATERING EQUIPMENT	-

ISSUE	DATE
1	OCT '88

EB 281

BRAKES
BOGIE/SUSPENSION
BODY CONSTRUCTION
COUPLINGS
TRAIN HEATING
MAX.SPEED M.P.H.
MIN.RAD.CURVE CHAINS
LIGHTING
TARE WEIGHT TONNES
GANGWAYS
A.W.S.
TRAIN COMMUNICATION
BUFFERS

S.R.DESIGN REFERENCE CODE

BASIC TYPE

ELECTRO PNEUMATIC
S.R.MK 3D POWERED & UNPOWERED(ONE OF EACH)
STEEL
AUTOMATIC DROPHEAD(BUCKEYE) OUTER END-3 LINK INNER END
ELECTRIC(BR)
75
3.5
FLUORESCENT & TUNGSTEN
42
NOT FITTED
NOT FITTED
DRIVER/GUARD
RETRACTABLE SPINDLE-559 X 356 OVAL OUTER END-CENTRE WEARING PLATE
INNER END
CY-3B

ALTERNATIVES

FITTED

TRACTION DATA FOR MULTIPLE UNITS

EMU- INTRODUCED 1954 REFURBISHED 1980 / 1 CONVERTED TO REVENUE PROTECTED UNITS 1986
VOLTAGE 750/850 VOLTS D.C.THIRD RAIL
TRACTION MOTORS 2 X 250 HP ENGLISH ELECTRIC

BASIC TYPE

EB 281 DA

VARIANTS

1A A.W.S.FITTED.

MOTOR SECOND

CLASS 317

MS

EC 202

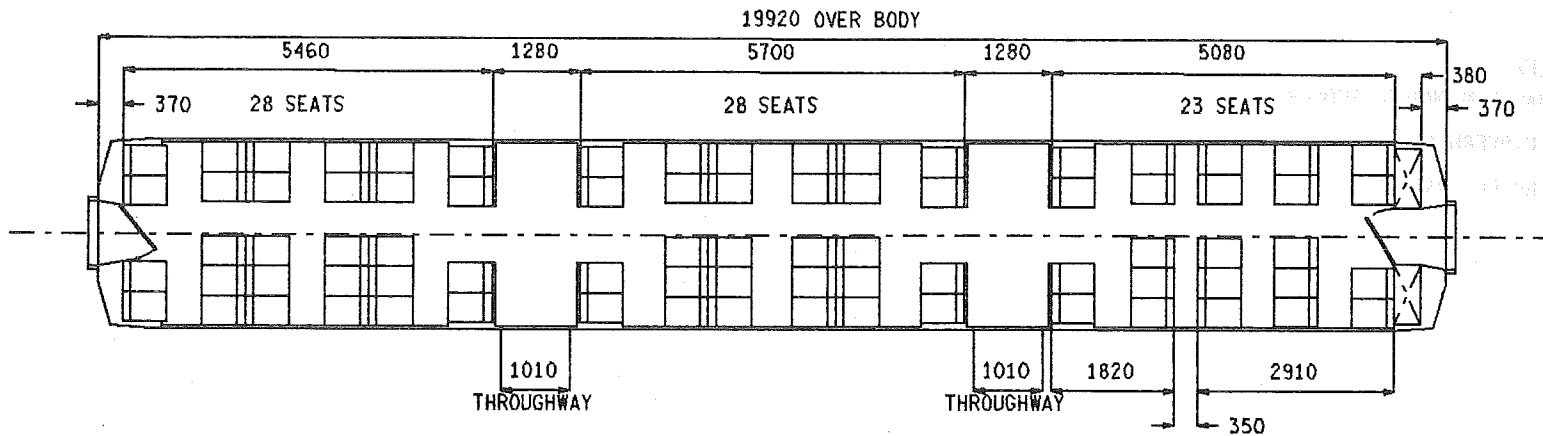
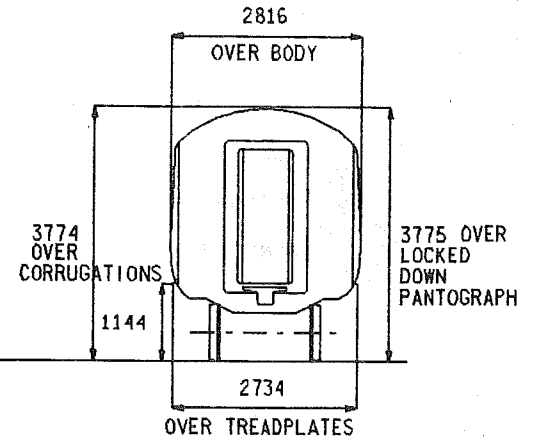
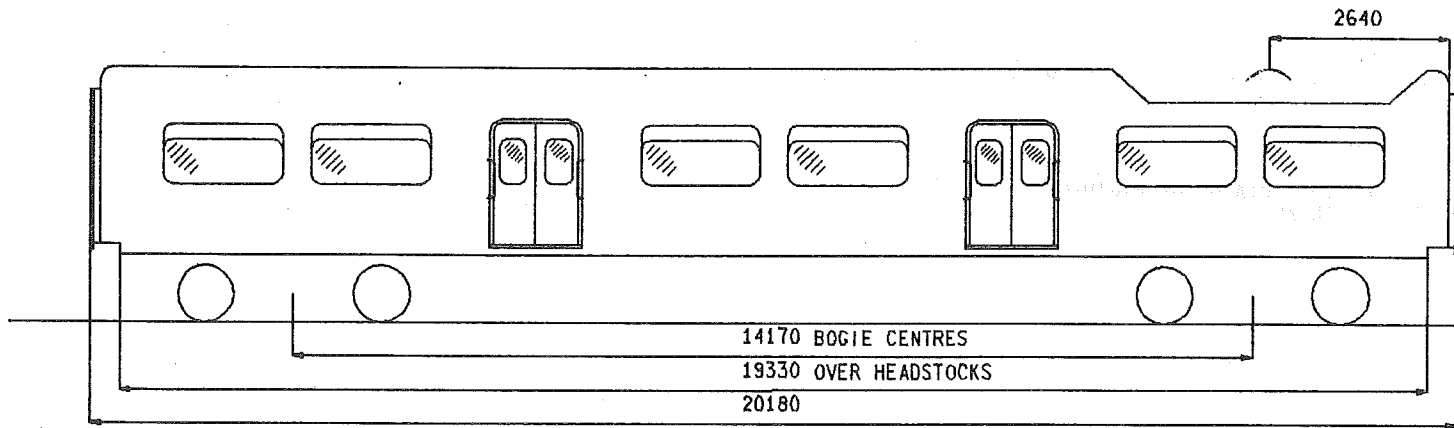

SEATS	79
TOILETS	-
COMPARTMENTS	-
GUARDS COMPARTMENTS	-
VENTILATION	PRESSURE
CATERING EQUIPMENT	-

ORIGINAL DIAGRAMS FOR REFERENCE:-
BR 483

ISSUE 4 DATE MAY '84

EC 202

BRAKES
BOGIE/SUSPENSION
BODY CONSTRUCTION
COUPLINGS
TRAIN HEATING
MAX. SPEED M.P.H.
MIN. RAD. CURVE CHAINS
LIGHTING
TARE WEIGHT TONNES
GANGWAYS
TRAIN COMMUNICATION
BUFFERS

BASIC TYPE

ELECTRO PNEUMATIC
BP20c & BP20d(ONE OF EACH)
STEEL
BAR
ELECTRIC(BR)WITH PRESSURE VENTILATION & HEATING
90
3.5
FLUORESCENT
49
FLEXIBLE DIAPHRAGM/RIGID(GRP)
PUBLIC ADDRESS
NOT FITTED

ALTERNATIVES

TRACTION DATA FOR MULTIPLE UNITS

EMU- ST.PANCRAS & MOORGATE-BEDFORD.
VOLTAGE 25 KV A.C.OVERHEAD
TRACTION MOTORS 4 X 332 HP GEC G315BZ

BASIC TYPE

EC 202 0A

VARIANTS

NONE

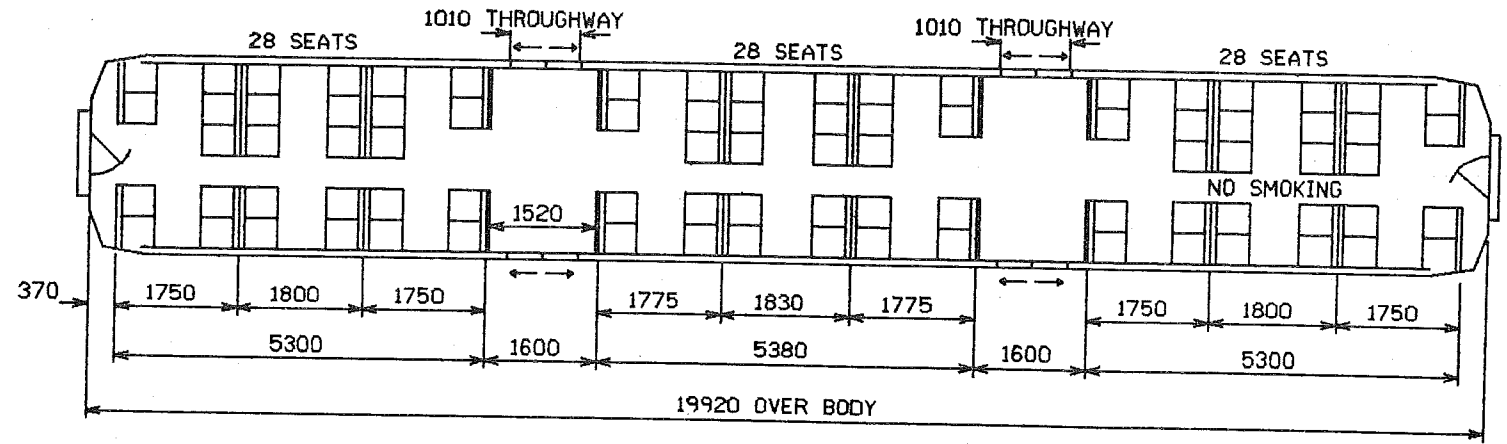
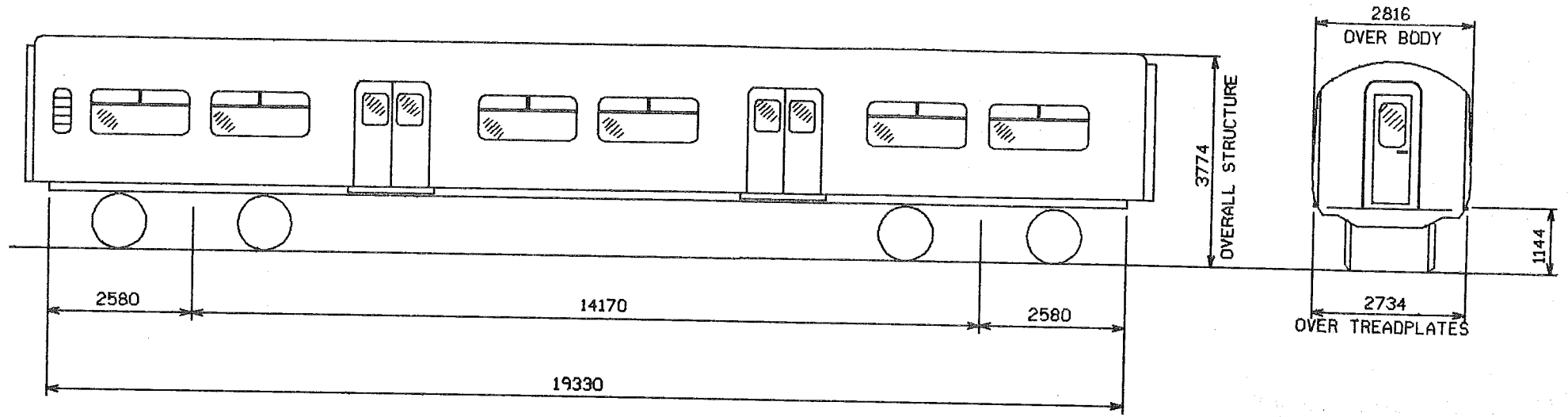

- SEATS 84
- TOILETS -
- COMPARTMENTS -
- GUARDS COMPARTMENTS -
- VENTILATION -
- CATERING EQUIPMENT -

ISSUE 3
DATE MAR 88

EC 203

BRAKES
BOGIE/SUSPENSION
BODY CONSTRUCTION
COUPLINGS
TRAIN HEATING
MAX SPEED M.P.H.
MIN.RAD.CURVE CHAINS
LIGHTING
TARE WEIGHT TONNES
GANGWAYS
TRAIN COMMUNICATION
BUFFERS
M.A.SET

BASIC TYPE

ELECTRO-PNEUMATIC
BP27
STEEL
BAR
ELECTRIC(BR)WITH PRESSURE VENTILATION & HEATING
75
3.5
FLUORESCENT
45.6
FLEXIBLE DIAPHRAGM/RIGID(GRP)
PUBLIC ADDRESS
NOT FITTED
G.E.C.

ALTERNATIVES

BRUSH

TRACTION DATA FOR MULTIPLE UNITS

EMU- SOUTHERN REGION ROUTES. INTRODUCED 1982.
VOLTAGE 750 VOLTS D.C.THIRD RAIL
TRACTION MOTORS 4 X 205 HP ENGLISH ELECTRIC 507-20J

BASIC TYPE

EC 203 0A

VARIANTS

1A BRUSH M.A.SET.

MOTOR SECOND

CLASS 307

MS

EC 204

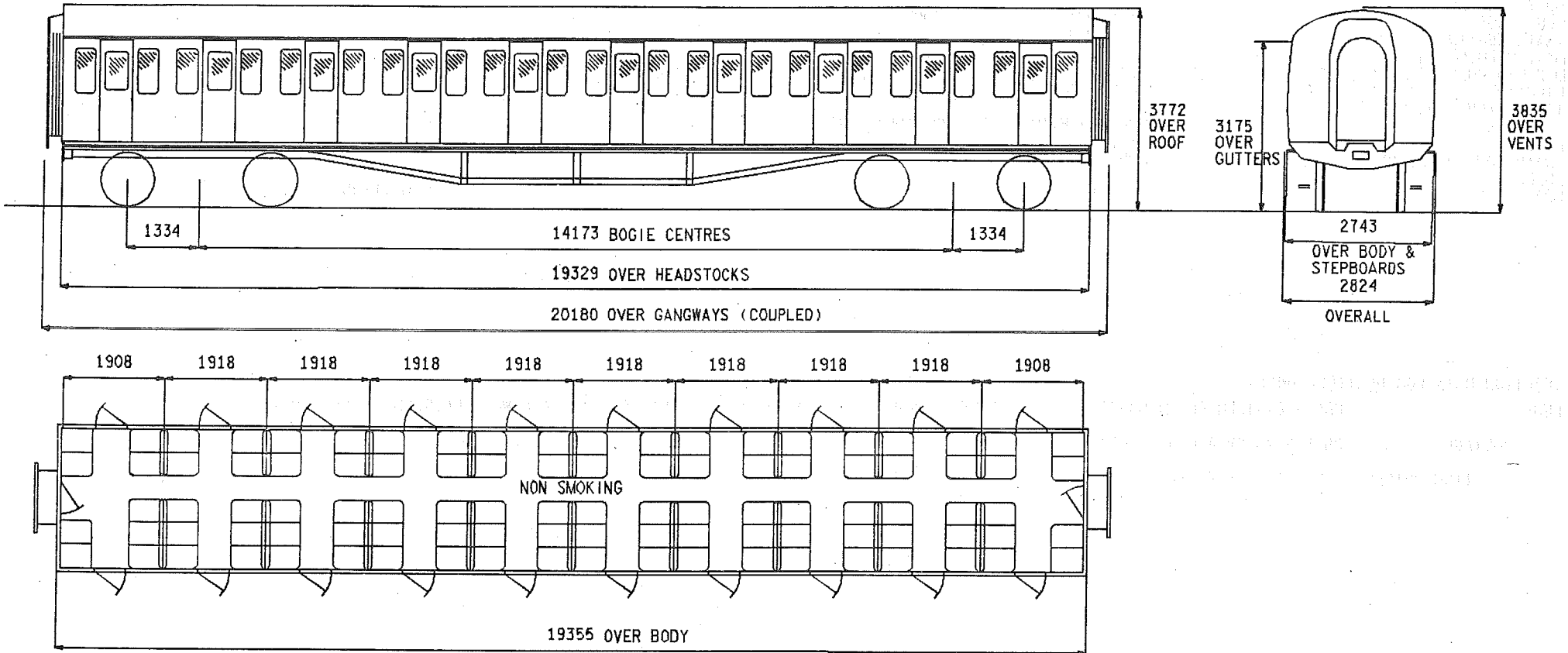

SEATS	98
TOILETS	-
COMPARTMENTS	-
GUARDS COMPARTMENTS	-
VENTILATION	-
CATERING EQUIPMENT	-

ISSUE 2 DATE AUG'82

MOTOR SECOND

CLASS 317/2

MS

EC 205

LOCKED DOWN PANTOGRAPH
HEIGHT 3775 ABOVE RAIL LEVEL

2640

2816

OVER BODY

3774

2734

OVER TREADPLATES

14170 BOGIE CENTRES

19330 OVER HEADSTOCKS

19920 OVER BODY

5460

1280

5700

1280

5080

380

NO SMOKING

1010
THRO'WAY

1010
THRO'WAY

SEATS	79
TOILETS	-
COMPARTMENTS	-
GUARDS COMPARTMENTS	-
VENTILATION	-
CATERING EQUIPMENT	-

ISSUE 3 DATE OCT 86

EC 205

BRAKES
BOGIE/SUSPENSION
BODY CONSTRUCTION
COUPLINGS
TRAIN HEATING
MAX.SPEED M.P.H.
MIN.RAD.CURVE CHAINS
LIGHTING
TARE WEIGHT TONNES
GANGWAYS

A.W.S.
TRAIN COMMUNICATION
BUFFERS

BASIC TYPE

ELECTRO-PNEUMATIC
BP20e & BP20f(ONE OF EACH)
STEEL
AUTOMATIC TIGHTLOCK OUTER END-BAR INNER END
ELECTRIC(BR)
90
3.5
FLUORESCENT & TUNGSTEN
49
CENTRALLY SUPPORTED-SWIVELLING-FLEXIBLE DIAPHRAGM-STEEL FACE PLATE
OUTER END-FLEXIBLE DIAPHRAGM/RIGID(GRP)INNER END
FITTED
DRIVER/SIGNAL BOX-DRIVER/GUARD-PUBLIC ADDRESS WITH TRANSMITTER
NOT FITTED

ALTERNATIVES

TRACTION DATA FOR MULTIPLE UNITS

EMU- GREAT NORTHERN OUTER SUBURBAN
VOLTAGE 25 KV A.C.OVERHEAD

BASIC TYPE

EC 205 0A

VARIANTS

NONE

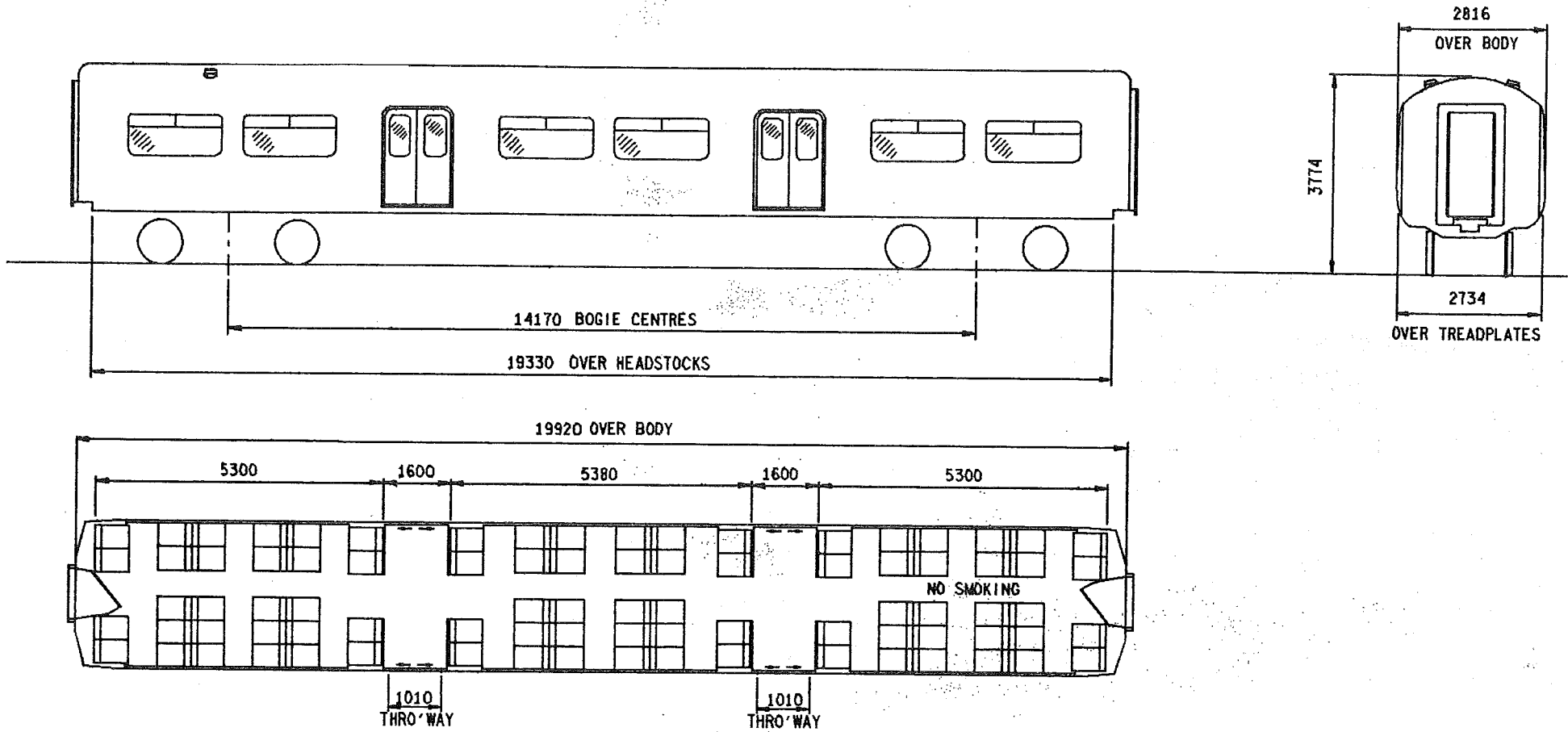

SEATS	84
TOILETS	-
COMPARTMENTS	-
GUARDS COMPARTMENTS	-
VENTILATION	-
CATERING EQUIPMENT	-

ISSUE 2 DATE MAR 88

EC 206

BRAKES
BOGIE/SUSPENSION
BODY CONSTRUCTION
COUPLINGS
TRAIN HEATING
MAX. SPEED M.P.H.
MIN. RAD. CURVE CHAINS
LIGHTING
TARE WEIGHT TONNES
GANGWAYS
TRAIN COMMUNICATION
BUFFERS
M.A. SET

BASIC TYPE

ELECTRO-PNEUMATIC
BP27
STEEL
BAR
ELECTRIC (BR)
75
3.5
FLUORESCENT
45.6
FLEXIBLE DIAPHRAM/RIGID (GRP)
PUBLIC ADDRESS
NOT FITTED
BRUSH

ALTERNATIVES

TRACTION DATA FOR MULTIPLE UNITS

EMU- SOUTHERN REGION ROUTES. INTRODUCED 1985
VOLTAGE 750 VOLTS D.C. THIRD RAIL
TRACTION MOTORS 4 X 205 HP ENGLISH ELECTRIC 507-20J

BASIC TYPE

EC 206 0A

VARIANTS

NONE

MOTOR SECOND

CLASS 318

MS

EC 207

LOCKED DOWN PANTOGRAPH
HEIGHT 3775 ABOVE RAIL LEVEL

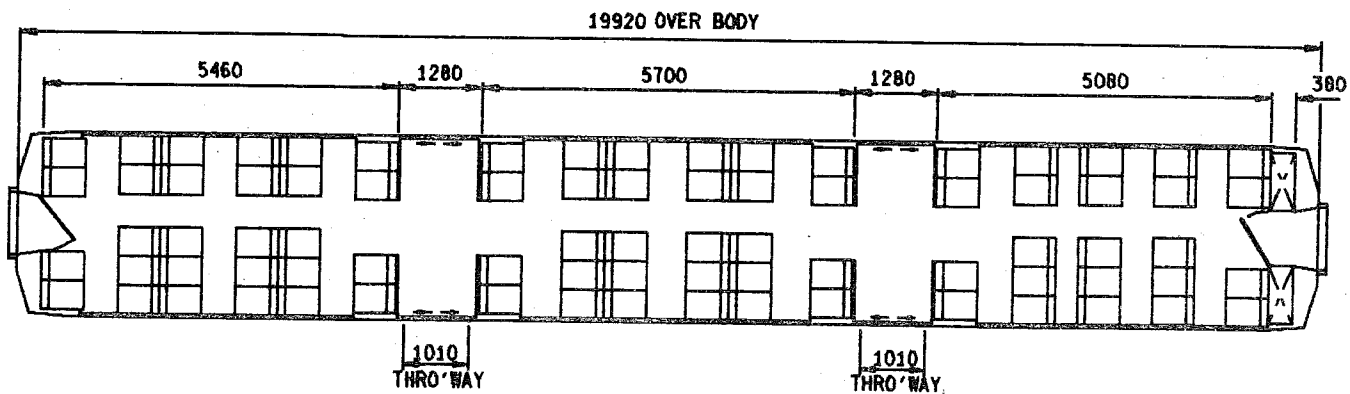
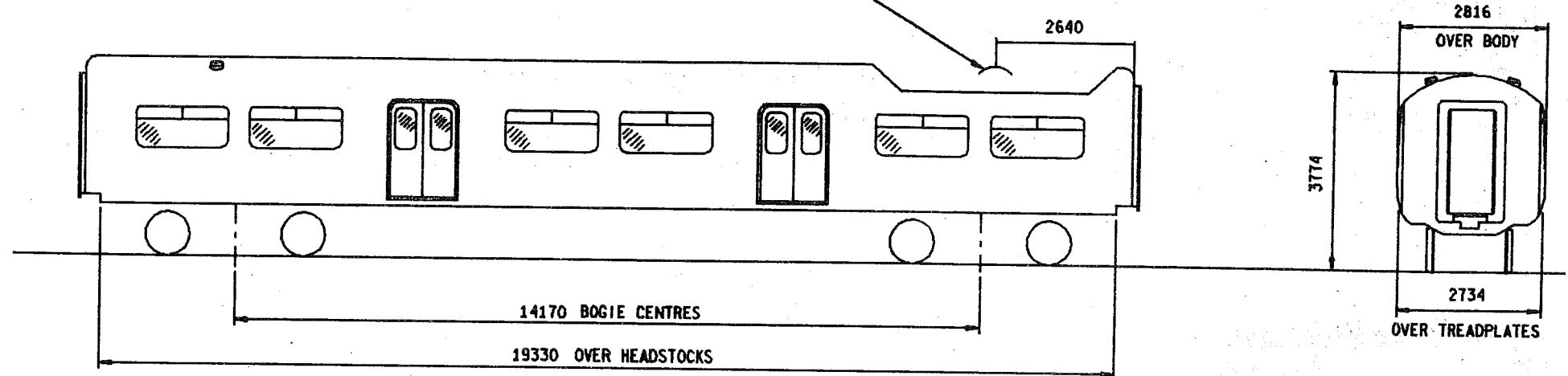

SEATS	79
TOILETS	-
COMPARTMENTS	-
GUARDS COMPARTMENTS	-
VENTILATION	-
CATERING EQUIPMENT	-

ISSUE DATE
1 OCT 86
(visit <http://www.barrowmoremrg.co.uk>)

EC 207

BRAKES
BOGIE/SUSPENSION
BODY CONSTRUCTION
COUPLINGS
TRAIN HEATING
MAX.SPEED M.P.H.
MIN.RAD.CURVE CHAINS
LIGHTING
TARE WEIGHT TONNES
GANGWAYS

A.W.S.
TRAIN COMMUNICATION
BUFFERS

BASIC TYPE

ELECTRO-PNEUMATIC
BP20e & BP20f(ONE OF EACH)
STEEL
AUTOMATIC TIGHTLOCK OUTER END-BAR INNER END
ELECTRIC(BR)
90
3.5
FLUORESCENT & TUNGSTEN
50.9
CENTRALLY SUPPORTED-SWIVELLING-FLEXIBLE DIAPHRAGM-STEEL FACE PLATE
OUTER END-FLEXIBLE DIAPHRAGM/RIGID(GRP) INNER END
FITTED
DRIVER/SIGNAL BOX-DRIVER/GUARD-PUBLIC ADDRESS WITH TRANSMITTER
NOT FITTED

ALTERNATIVES

TRACTION DATA FOR MULTIPLE UNITS

EMU- GLASGOW AREA
VOLTAGE 25 KV A.C.OVERHEAD

BASIC TYPE

EC 207 0A

VARIANTS

NONE

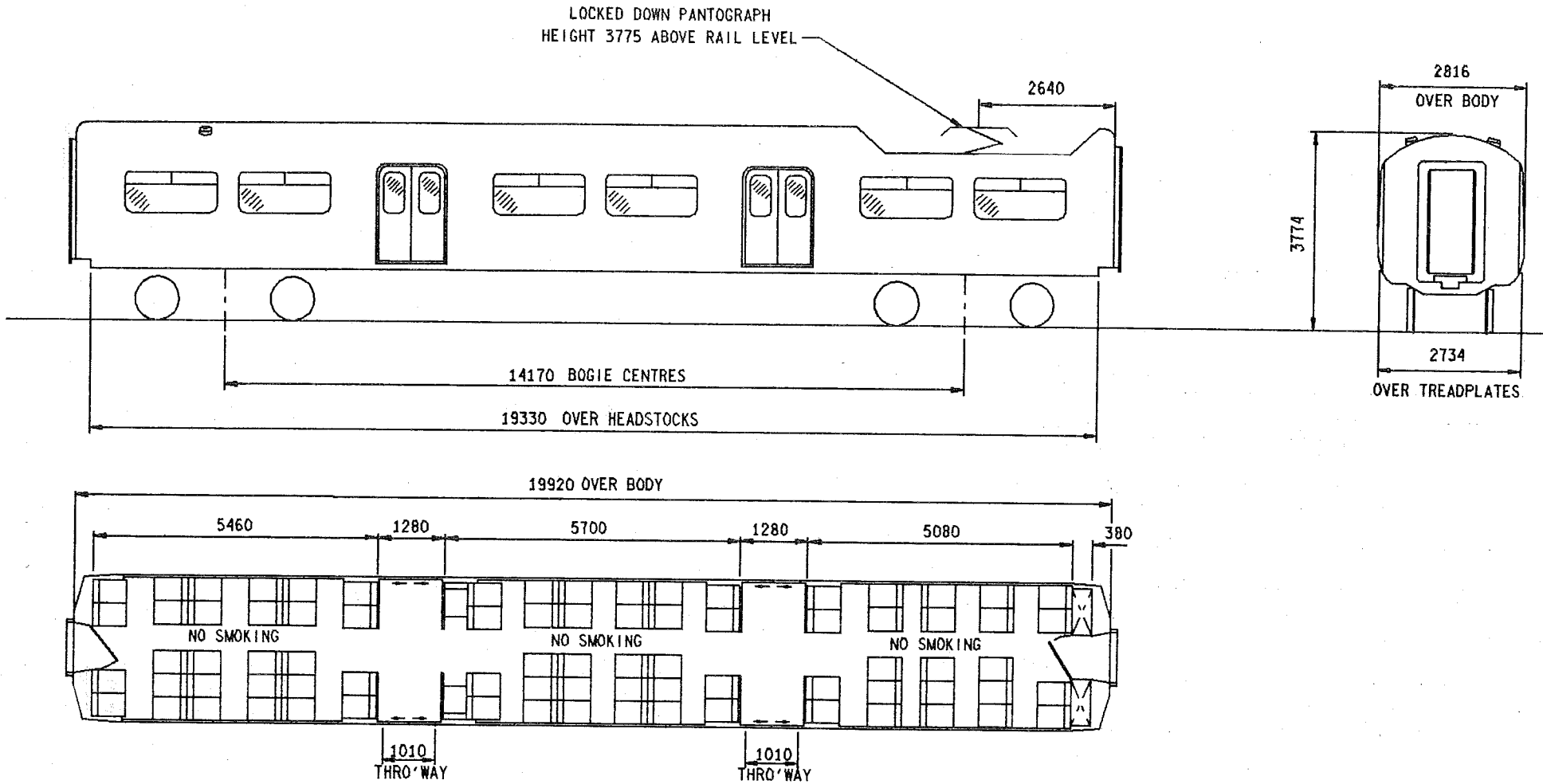

SEATS	81
TOILETS	-
COMPARTMENTS	-
GUARDS COMPARTMENTS	-
VENTILATION	-
CATERING EQUIPMENT	-

ISSUE DATE
1 JAN 88

EC 209

BRAKES
BOGIE/SUSPENSION
BODY CONSTRUCTION
COUPLINGS
TRAIN HEATING
MAX.SPEED M.P.H.
MIN.RAD.CURVE CHAINS
LIGHTING
TARE WEIGHT TONNES
GANGWAYS
A.W.S.
TRAIN COMMUNICATION
BUFFERS

BASIC TYPE

ELECTRO-PNEUMATIC
P7-4b & P7-4a(ONE OF EACH)
STEEL
BAR
ELECTRIC(BR)
100
3.5
FLUORESCENT
49.2
FLEXIBLE DIAPHRAGM/RIGID(GRP)
FITTED
PUBLIC ADDRESS
NOT FITTED

ALTERNATIVES

TRACTION DATA FOR MULTIPLE UNITS

EMU- CROSS LONDON SERVICES.INTRODUCED 1987
VOLTAGE 25 KV A.C.OVERHEAD & 750V D.C.THIRD RAIL

BASIC TYPE

EC 209 0A

VARIANTS

NONE

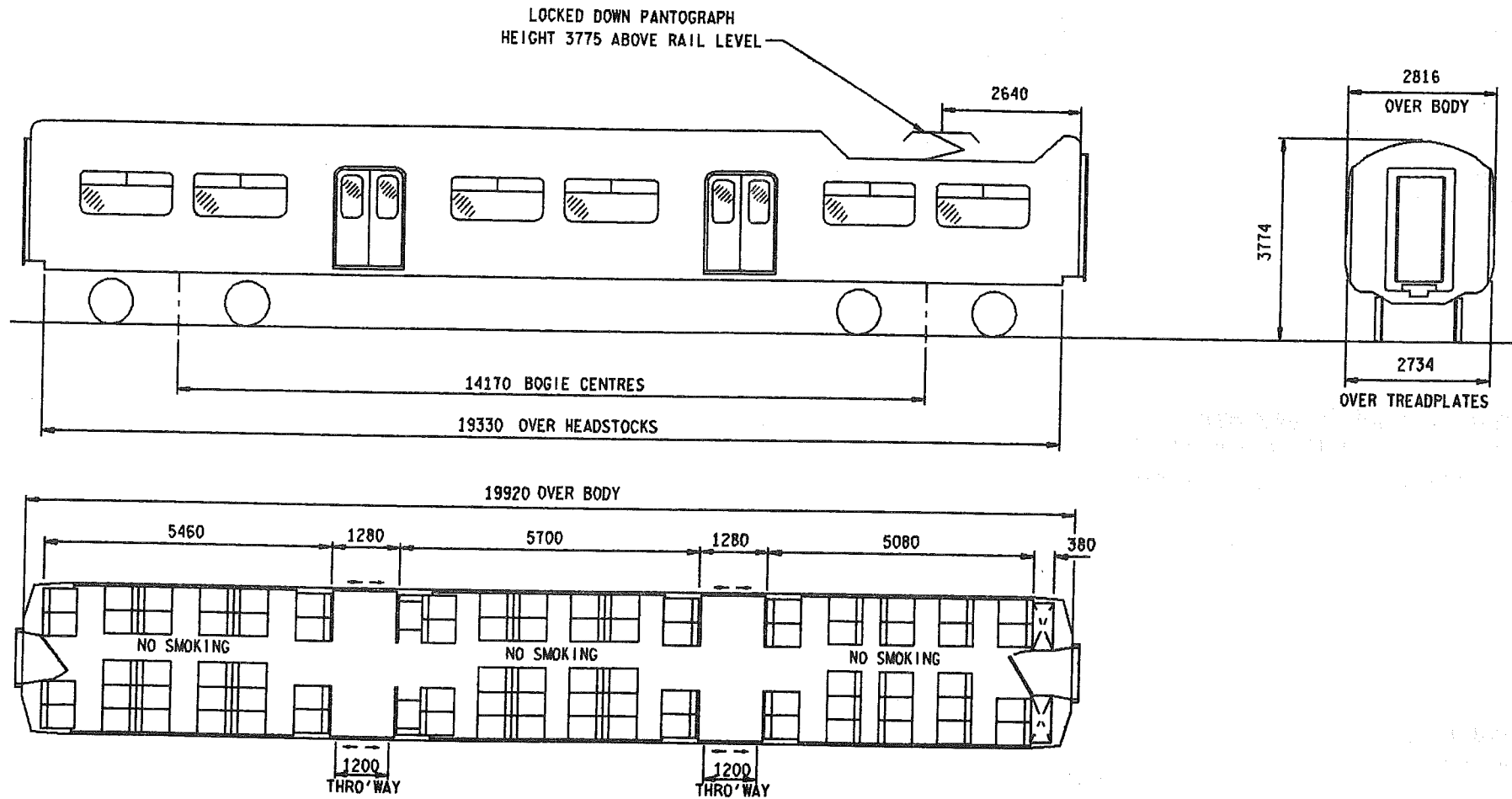

- SEATS 81
- TOILETS -
- COMPARTMENTS -
- GUARDS COMPARTMENTS -
- VENTILATION -
- CATERING EQUIPMENT -

ISSUE 1 DATE OCT 88

EC 210

BRAKES
BOGIE/SUSPENSION
BODY CONSTRUCTION
COUPLINGS
TRAIN HEATING
MAX. SPEED M.P.H.
MIN. RAD. CURVE METRES
LIGHTING
TARE WEIGHT TONNES
GANGWAYS
A.W.S.
TRAIN COMMUNICATION
BUFFERS

BASIC TYPE

ELECTRO-PNEUMATIC
P7-4c & P7-4d(ONE OF EACH)
STEEL
BAR
ELECTRIC(BR)
100
71
FLUORESCENT
51.5
FLEXIBLE DIAPHRAGM/RIGID(GRP)
FITTED
PUBLIC ADDRESS
NOT FITTED

ALTERNATIVES

TRACTION DATA FOR MULTIPLE UNITS

EMU- ANGLIA-ELECTRICS INTRODUCED 1988/89
VOLTAGE 25 KV A.C.OVERHEAD

BASIC TYPE

EC 210 0A

VARIANTS

NONE

MOTOR BRAKE SECOND

CLASS 303

MBS

ED 201

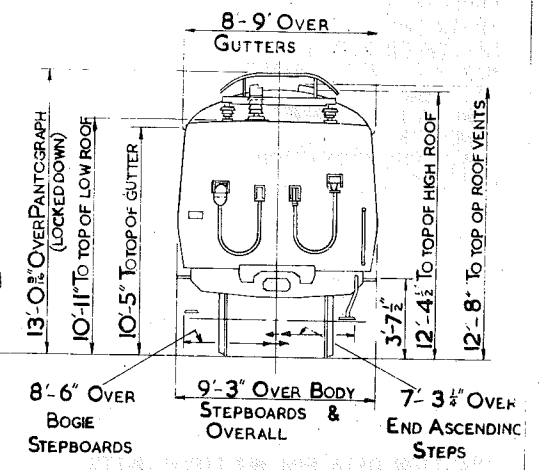
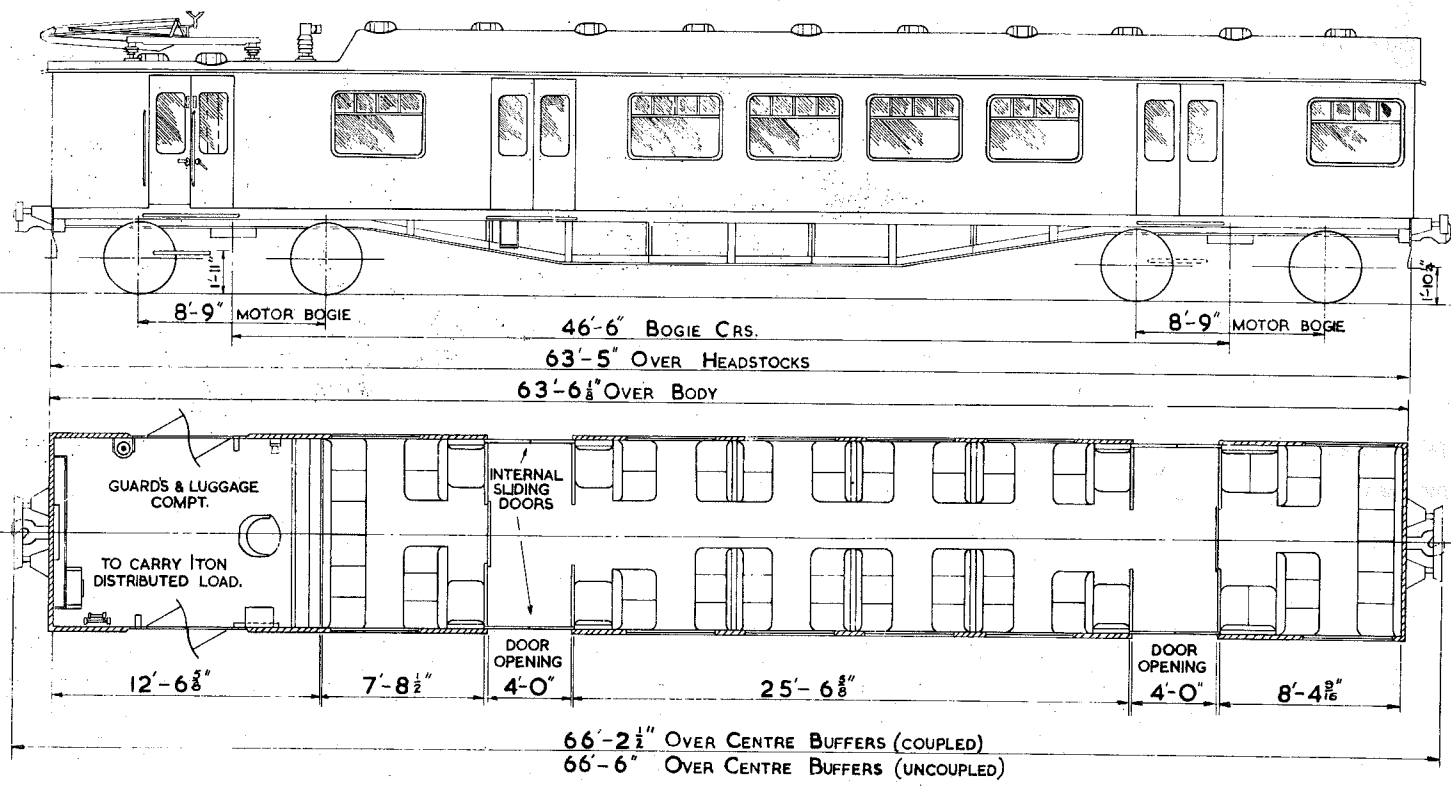

SEATS	70
TOILETS	-
COMPARTMENTS	-
GUARDS COMPARTMENTS	1
VENTILATION	-
CATERING EQUIPMENT	-

ORIGINAL DIAGRAMS FOR REFERENCE.-
BR 416

ISSUE 1 DATE SEP' 80

ED 201

BRAKES
BOGIE/SUSPENSION
BODY CONSTRUCTION
COUPLINGS
TRAIN HEATING
MAX. SPEED M.P.H.
MIN. RAD. CURVE CHAINS
LIGHTING
TARE WEIGHT TONNES
GANGWAYS
TRAIN COMMUNICATION
BUFFERS

BASIC TYPE

ELECTRO PNEUMATIC
GRESLEY ED3 *SCDN. 22172.*
STEEL
AUTOMATIC SOLID SHANK (ALLIANCE NO.2)
ELECTRIC (BR)
75
3.5
ELECTRIC
56
NOT FITTED
NOT FITTED
NOT FITTED

ALTERNATIVES

TRACTION DATA FOR MULTIPLE UNITS

EMU- GLASGOW AREA. INTRODUCED 1960.
VOLTAGE 25 & 6.25 KV A.C. OVERHEAD
TRACTION MOTORS 4 X 27 HP D.C. A.E.I.

BASIC TYPE

ED 201 0A

VARIANTS

NONE

MOTOR BRAKE SECOND

CLASS 304/2
304/3

MBS

ED 203

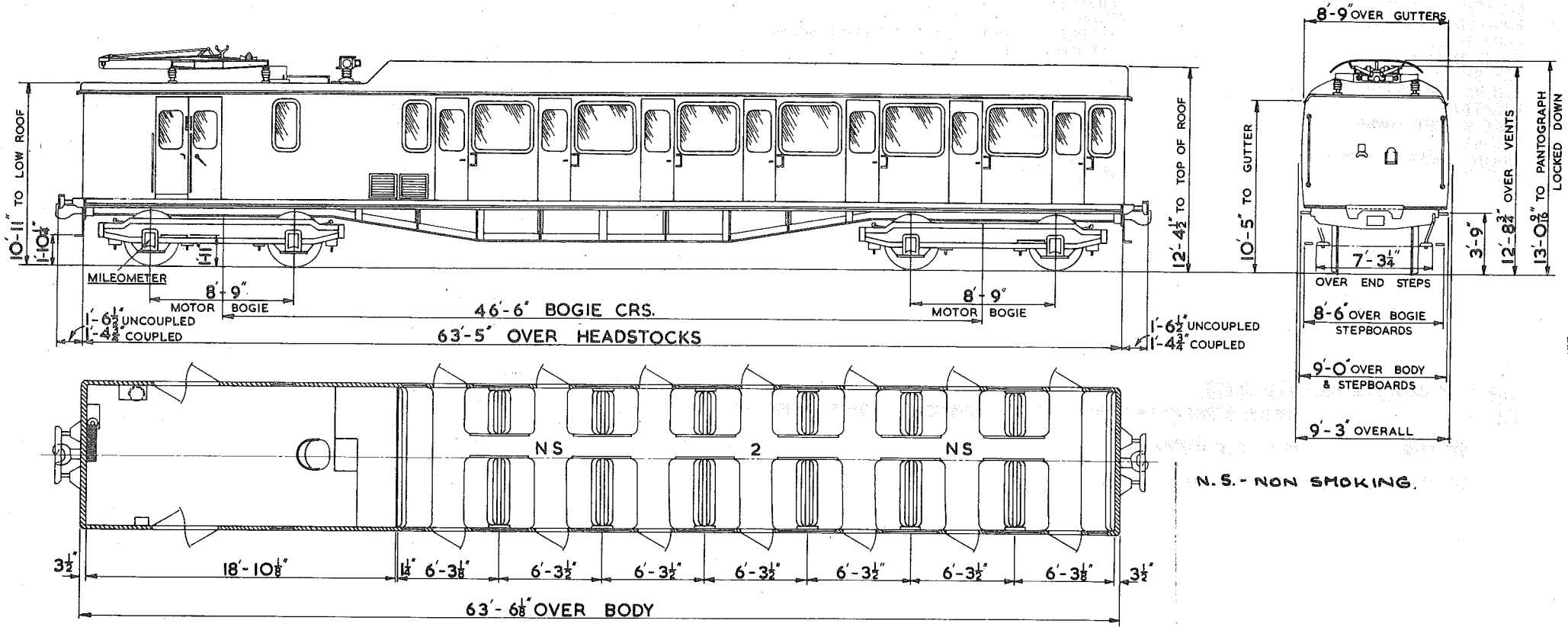

N.S. - NON SMOKING.

SEATS	72
TOILETS	-
COMPARTMENTS	-
GUARDS COMPARTMENTS	1
VENTILATION	-
CATERING EQUIPMENT	-

ORIGINAL DIAGRAMS FOR REFERENCE.-
BR 409

ISSUE 1 DATE SEP' 80

ED 203

BRAKES
BOGIE/SUSPENSION
BODY CONSTRUCTION
COUPLINGS
TRAIN HEATING
MAX. SPEED M. P. H.
MIN. RAD. CURVE CHAINS
LIGHTING
TARE WEIGHT TONNES
GANGWAYS
TRAIN COMMUNICATION
BUFFERS

BASIC TYPE

ELECTRO PNEUMATIC
GRESLEY ED4
STEEL
AUTOMATIC SOLID SHANK (ALLIANCE NO.2)
ELECTRIC (BR)
75
3.5
ELECTRIC
54.5
NOT FITTED
NOT FITTED
NOT FITTED

ALTERNATIVES

TRACTION DATA FOR MULTIPLE UNITS

EMU- EUSTON-BIRMINGHAM-MANCHESTER & LIVERPOOL. INTRODUCED 1960
VOLTAGE 25 KV A.C.OVERHEAD
TRACTION MOTORS 4 X 207 HP D.C. A.E.I.

BASIC TYPE

ED 203 0A

VARIANTS

NONE

MOTOR BRAKE SECOND

CLASS 305/1

MBS

ED 204

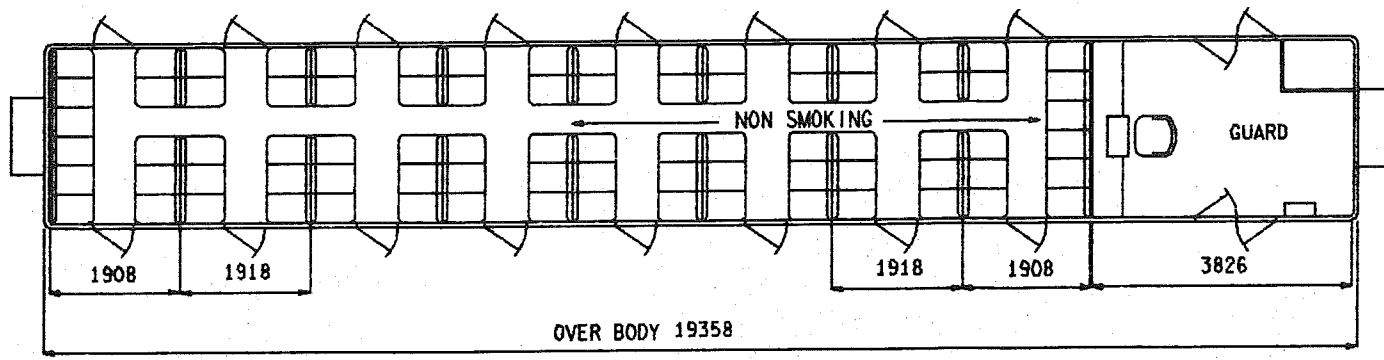
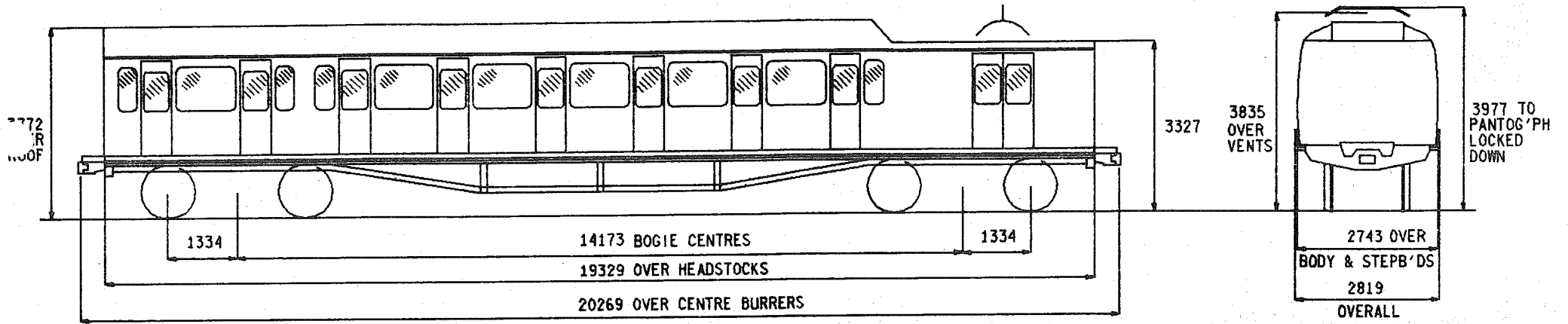

SEATS	82
TOILETS	-
COMPARTMENTS	-
GUARDS COMPARTMENTS	1
VENTILATION	-
CATERING EQUIPMENT	-

ORIGINAL DIAGRAMS FOR REFERENCE:-
BR 413

ISSUE 6 DATE MAR 87

ED 204

BASIC TYPE

BRAKES
BOGIE/SUSPENSION
BODY CONSTRUCTION
COUPLINGS
TRAIN HEATING
MAX.SPEED M.P.H.
MIN.RAD.CURVE CHAINS
LIGHTING
TARE WEIGHT TONNES
GANGWAYS
TRAIN COMMUNICATION
BUFFERS
BRAKE BLOCKS

ELECTRO PNEUMATIC
GRESLEY ED5
STEEL
AUTOMATIC SOLID SHANK (ALLIANCE NO.2)
ELECTRIC (BR)
75
3.5
FLUORESCENT & TUNGSTEN
55
NOT FITTED
NOT FITTED
NOT FITTED
CAST IRON

ALTERNATIVES

PUBLIC ADDRESS WITH TRANSMITTER
COMPOSITION

TRACTION DATA FOR MULTIPLE UNITS

EMU- LIVERPOOL ST.-ENFIELD-CHINGFORD. INTRODUCED 1960, REFURBISHED 1980.
VOLTAGE 25 & 6.25 KV A.C.OVERHEAD
TRACTION MOTORS 4 X 200 HP D.C.GEC

BASIC TYPE

ED 204 OA-REFURBISHED

VARIANTS

0B-REFURBISHED COMPOSITION BRAKES BLOCKS.
1C-REFURBISHED, PUBLIC ADDRESS WITH TRANSMITTER.
1D-REFURBISHED, PUBLIC ADDRESS WITH TRANSMITTER, COMPOSITION BRAKES BLOCKS.

MOTOR BRAKE SECOND

CLASS 302

MBS

ED 205

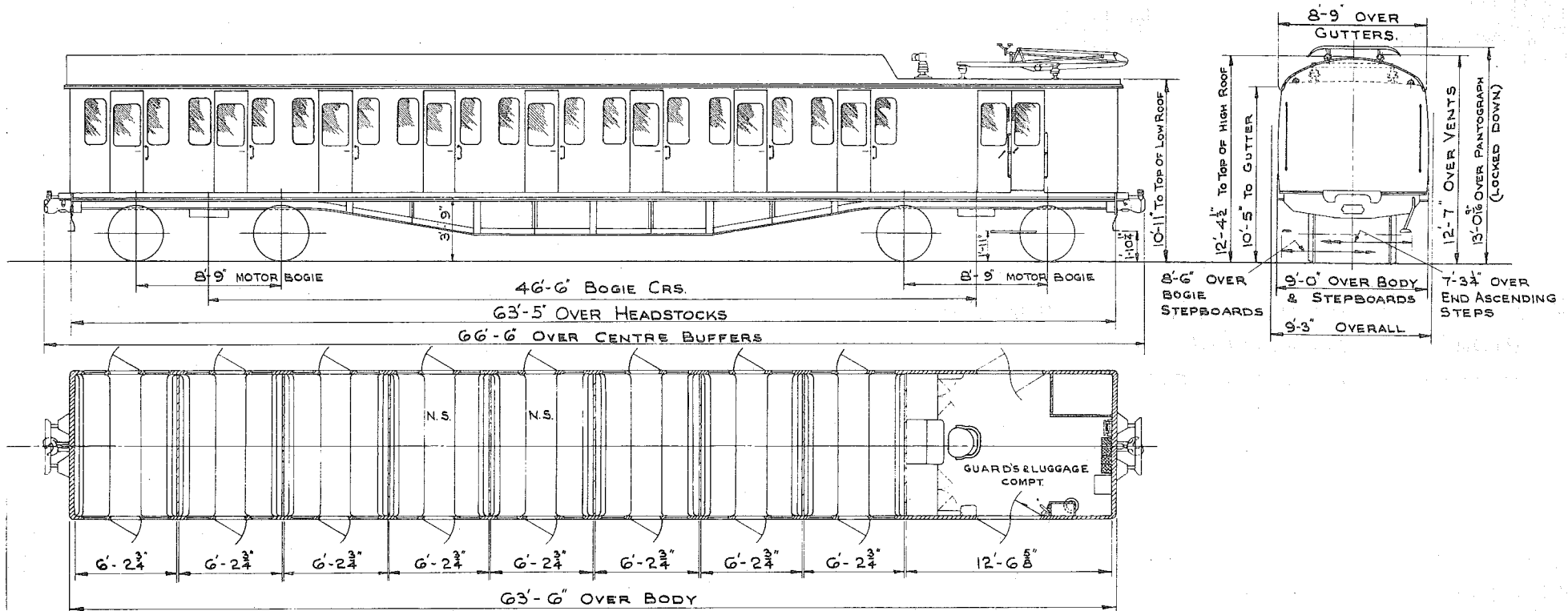

SEATS	96
TOILETS	-
COMPARTMENTS	8
GUARDS COMPARTMENTS	1
VENTILATION	-
CATERING EQUIPMENT	-

ORIGINAL DIAGRAMS FOR REFERENCE:-
BR 405

ISSUE 2 DATE AUG '83

ED 205

BRAKES
BOGIE/SUSPENSION
BODY CONSTRUCTION
COUPLINGS
TRAIN HEATING
MAX.SPEED M.P.H.
MIN.RAD.CURVE CHAINS
LIGHTING
TARE WEIGHT TONNES
GANGWAYS
TRAIN COMMUNICATION
BUFFERS

BASIC TYPE

ELECTRO PNEUMATIC
GRESLEY ED2
STEEL
AUTOMATIC SOLID SHANK (ALLIANCE NO.2)
ELECTRIC (BR)
75
3.5
TUNGSTEN
55
NOT FITTED
NOT FITTED
NOT FITTED

ALTERNATIVES

TRACTION DATA FOR MULTIPLE UNITS

EMU- FENCHURCH ST.-SHOEBURYNESS. INTRODUCED 1960.
VOLTAGE 25 & 6.25 KV A.C.OVERHEAD
TRACTION MOTORS 4 X 192 HP D.C.ENGLISH ELECTRIC ELECTRIC

BASIC TYPE

ED 205 OA

VARIANTS

NONE

MOTOR BRAKE SECOND

CLASS 310

MBS

ED 210

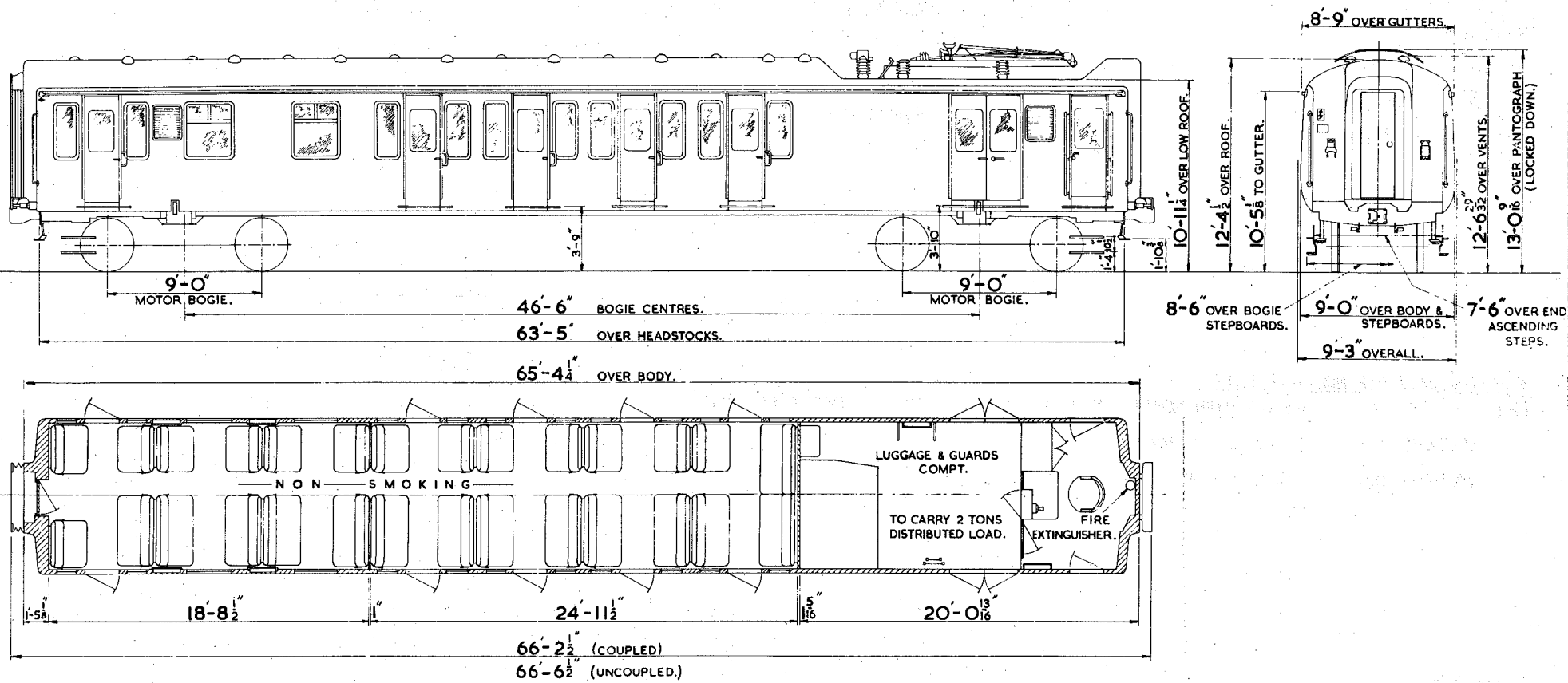

SEATS	70
TOILETS	-
COMPARTMENTS	-
GUARDS COMPARTMENTS	1
VENTILATION	-
CATERING EQUIPMENT	-

ORIGINAL DIAGRAMS FOR REFERENCE. - BR 424

ISSUE	DATE
1	SEP' 80

ED 210

BRAKES
BOGIE/SUSPENSION
BODY CONSTRUCTION
COUPLINGS
TRAIN HEATING
MAX. SPEED M.P.H.
MIN. RAD. CURVE CHAINS
LIGHTING
TARE WEIGHT TONNES
GANGWAYS
TRAIN COMMUNICATION
BUFFERS

BASIC TYPE

ELECTRO PNEUMATIC
B4/AM10
STEEL
AUTOMATIC SOLID SHANK (BUCKEYE)
ELECTRIC (BR)
75
3.5
ELECTRIC
57
EXPRESS ELECTRIC INNER END ONLY
NOT FITTED
NOT FITTED

ALTERNATIVES

TRACTION DATA FOR MULTIPLE UNITS

EMU- EUSTON-BIRMINGHAM-MANCHESTER & LIVERPOOL. INTRODUCED 1966.
VOLTAGE 25 KV A.C. OVERHEAD
TRACTION MOTORS 4 X 270 HP D.C. ENGLISH ELECTRIC

BASIC TYPE

ED 210 0A

VARIANTS

NONE

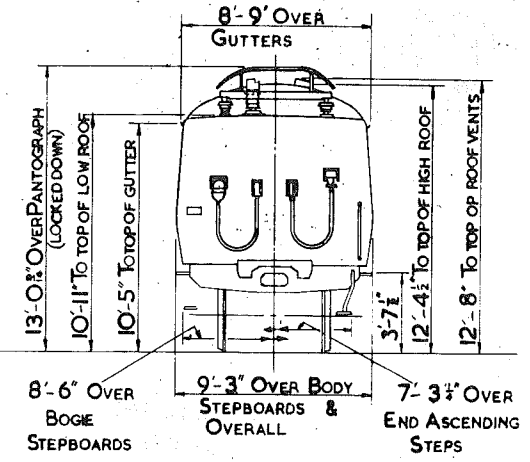
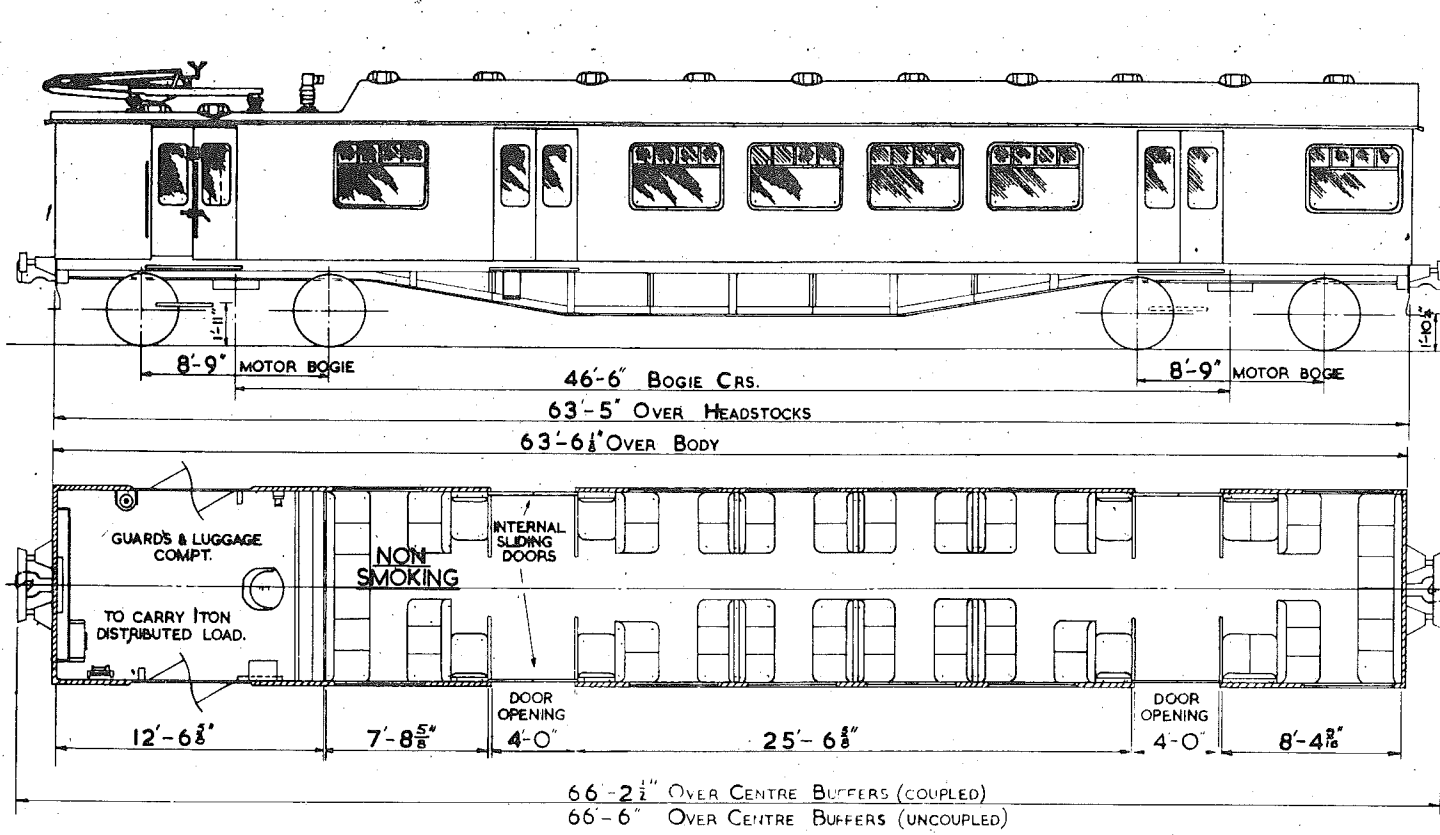

SEATS	70
TOILETS	-
COMPARTMENTS	-
GUARDS COMPARTMENTS	1
VENTILATION	-
CATERING EQUIPMENT	-

ORIGINAL DIAGRAMS FOR REFERENCE.-
BR 385

ISSUE 2 DATE MAY '81

ED 211

BRAKES
BOGIE/SUSPENSION
BODY CONSTRUCTION
COUPLINGS
TRAIN HEATING
MAX. SPEED M.P.H.
MIN. RAD. CURVE CHAINS
LIGHTING
TARE WEIGHT TONNES
GANGWAYS
TRAIN COMMUNICATION
BUFFERS

BASIC TYPE

ELECTRO PNEUMATIC
GRESLEY ED11
STEEL
AUTOMATIC SOLID SHANK (ALLIANCE NO. 2)
ELECTRIC (BR)
75
3.5
TUNGSTEN
58
NOT FITTED
NOT FITTED
NOT FITTED

ALTERNATIVES

TRACTION DATA FOR MULTIPLE UNITS

EMU- GLASGOW AREA. INTRODUCED 1967.
VOLTAGE 25 & 6.25 KV A.C. OVERHEAD
TRACTION MOTORS 4 X 222 HP D.C. A.E.I.

BASIC TYPE

ED 211 0A

VARIANTS

NONE

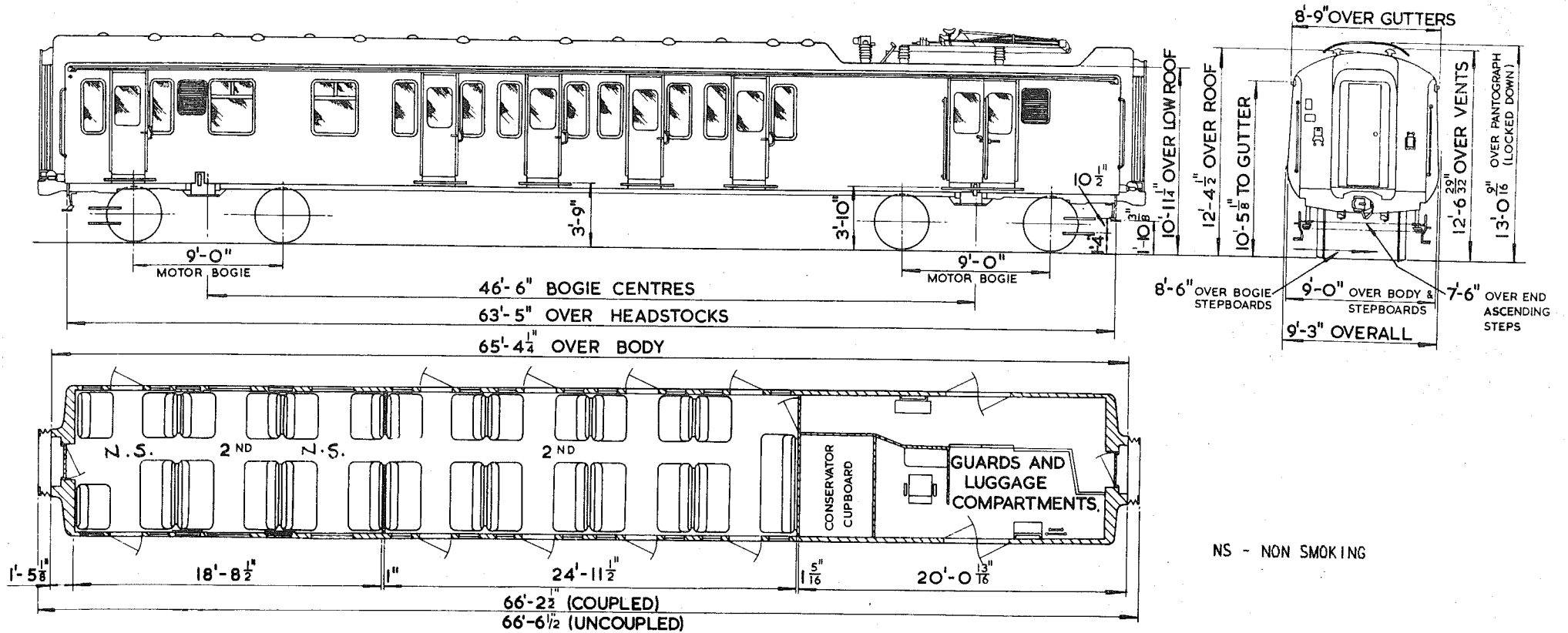

NS - NON SMOKING

SEATS	68
TOILETS	-
COMPARTMENTS	-
GUARDS COMPARTMENTS	1
VENTILATION	-
CATERING EQUIPMENT	-

ORIGINAL DIAGRAMS FOR REFERENCE:-
BR 490

ISSUE 3 DATE MAR 87

ED 212

BRAKES
BOGIE/SUSPENSION
BODY CONSTRUCTION
COUPLINGS
TRAIN HEATING
MAX. SPEED M.P.H.
MIN. RAD. CURVE CHAINS
LIGHTING
TARE WEIGHT TONNES
GANGWAYS
TRAIN COMMUNICATION
BUFFERS

BASIC TYPE

ELECTRO PNEUMATIC
BP14 & BP14a ONE OF EACH
STEEL
AUTOMATIC SOLID SHANK (ALLIANCE NO. 2)
ELECTRIC (BR)
90
3.5
FLUORESCENT & TUNGSTEN
56
BR STANDARD MK 2
NOT FITTED
NOT FITTED

ALTERNATIVES

TRACTION DATA FOR MULTIPLE UNITS

EMU- GREAT NORTHERN OUTER SUBURBAN, INTRODUCED 1975
VOLTAGE 25 KV A.C. OVERHEAD
TRACTION MOTORS 4 X 270 HP D.C. GEC

BASIC TYPE

ED 212 OA

VARIANTS

NONE

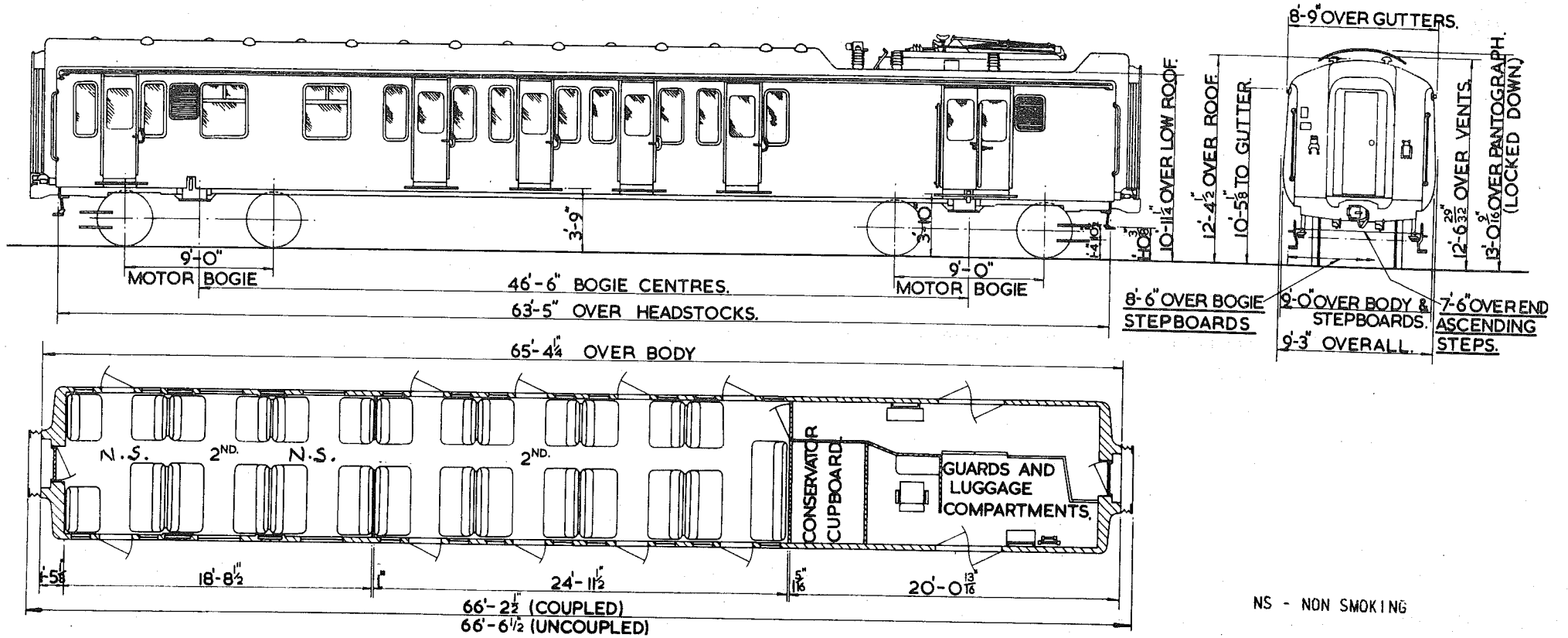

NS - NON SMOKING

SEATS	68
TOILETS	-
COMPARTMENTS	-
GUARDS COMPARTMENTS	1
VENTILATION	-
CATERING EQUIPMENT	-

ORIGINAL DIAGRAMS FOR REFERENCE:-
BR 491

ISSUE 3 DATE MAR 87

ED 213

BRAKES
BOGIE/SUSPENSION
BODY CONSTRUCTION
COUPLINGS
TRAIN HEATING
MAX. SPEED M.P.H.
MIN. RAD. CURVE CHAINS
LIGHTING
TARE WEIGHT TONNES
GANGWAYS
TRAIN COMMUNICATION
BUFFERS

BASIC TYPE

ELECTRO PNEUMATIC
BP14 & BP14a (ONE OF EACH)
STEEL
AUTOMATIC SOLID SHANK (ALLIANCE No. 2)
ELECTRIC (BR)
90
3.5
FLUORESCENT & TUNGSTEN
55.5
BR STANDARD MK 2
NOT FITTED
NOT FITTED

ALTERNATIVES

TRACTION DATA FOR MULTIPLE UNITS

EMU- GREAT EASTERN OUTER SUBURBAN, INTRODUCED 1975
VOLTAGE 25 & 6.25 KV A.C. OVERHEAD
TRACTION MOTORS 4 X 270 HP D.C. GEC

BASIC TYPE

ED 213 0A

VARIANTS

NONE

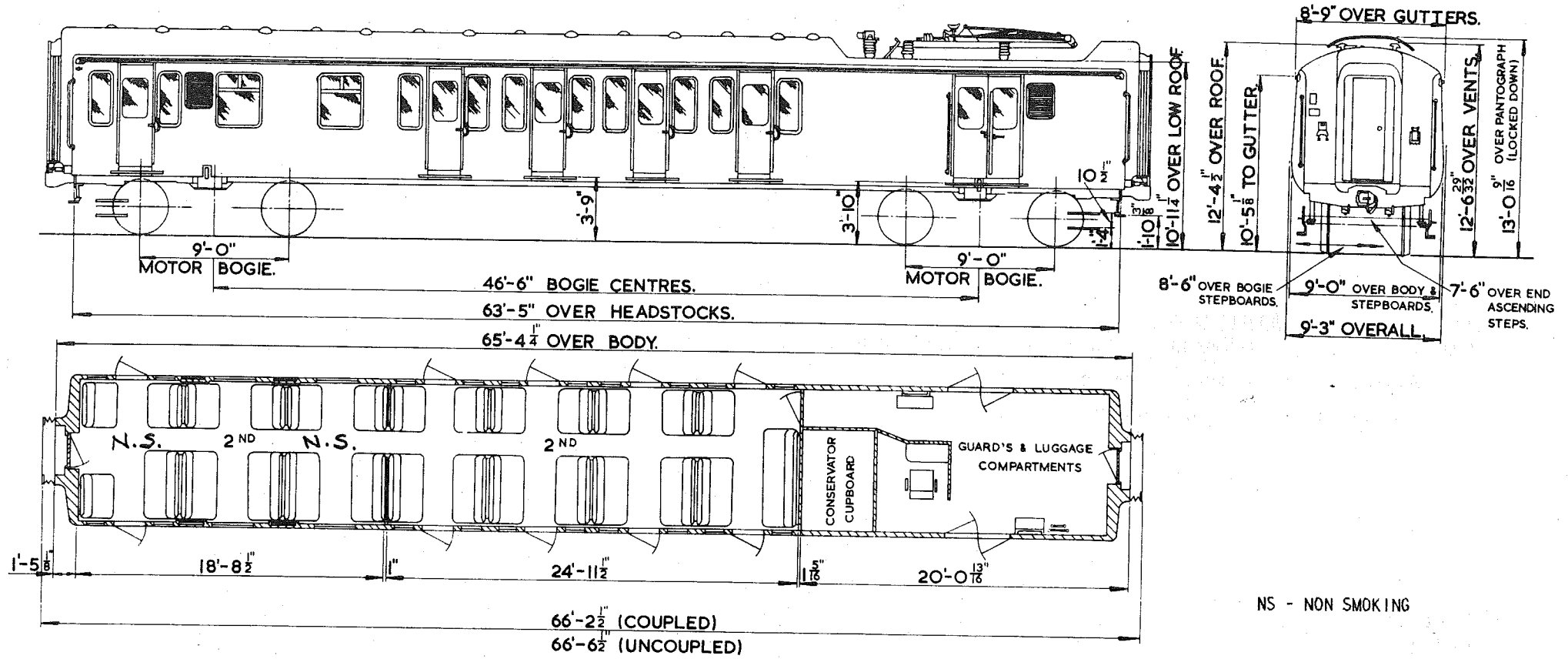

NS - NON SMOKING

SEATS	68
TOILETS	-
COMPARTMENTS	-
GUARDS COMPARTMENTS	1
VENTILATION	-
CATERING EQUIPMENT	-

ORIGINAL DIAGRAMS FOR REFERENCE:-
BR 492

ISSUE 3 DATE MAR 87

ED 214

BRAKES
BOGIE/SUSPENSION
BODY CONSTRUCTION
COUPLINGS
TRAIN HEATING
MAX.SPEED M.P.H.
MIN.RAD.CURVE CHAINS
LIGHTING
TARE WEIGHT TONNES
GANGWAYS
TRAIN COMMUNICATION
BUFFERS

BASIC TYPE

ELECTRO PNEUMATIC
BP14b & BP14c (ONE OF EACH)
STEEL
AUTOMATIC SOLID SHANK (ALLIANCE NO.2)
ELECTRIC (BR)
75
3.5
FLUORESCENT & TUNGSTEN
55.5
BR STANDARD MK 2
NOT FITTED
NOT FITTED

ALTERNATIVES

TRACTION DATA FOR MULTIPLE UNITS

EMU- LONDON MIDLAND OUTER SUBURBAN, INTRODUCED 1975
VOLTAGE 25 KV A.C.OVERHEAD
TRACTION MOTORS 4 X 270 HP D.C.GEC

BASIC TYPE

ED 214 0A

VARIANTS

NONE

MOTOR BRAKE SECOND

CLASS 304/1

MBS

ED 215

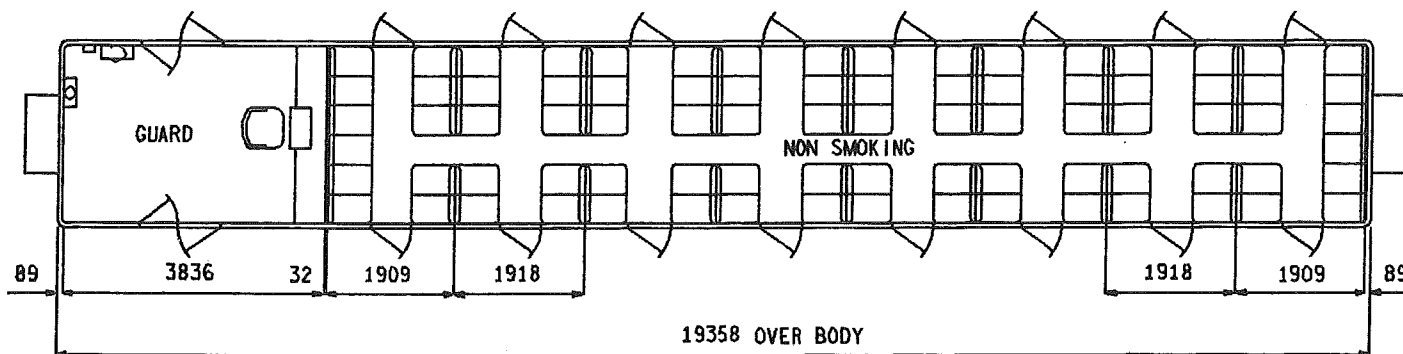
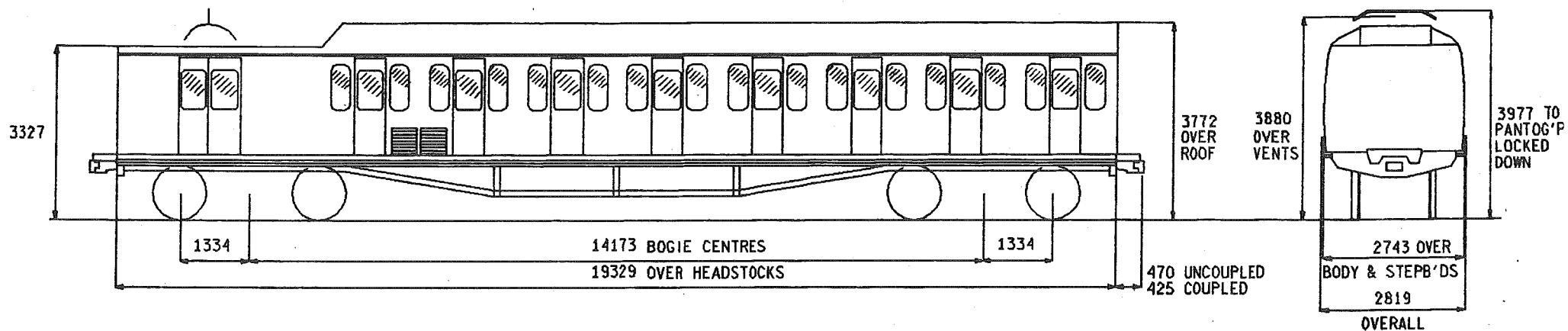

MODIFIED FROM ED 202 UNDER MOD.No. MB 9241/028

SEATS	82
TOILETS	-
COMPARTMENTS	-
GUARDS COMPARTMENTS	1
VENTILATION	-
CATERING EQUIPMENT	-

ORIGINAL DIAGRAMS FOR REFERENCE:- BR 408

ISSUE 4 DATE APR 86

ED 215

BRAKES
BOGIE/SUSPENSION
BODY CONSTRUCTION
COUPLINGS
TRAIN HEATING
MAX. SPEED M.P.H.
MIN. RAD. CURVE CHAINS
LIGHTING
TARE WEIGHT TONNES
GANGWAYS
TRAIN COMMUNICATION
BUFFERS

BASIC TYPE

ELECTRO PNEUMATIC
GRESLEY ED4
STEEL
AUTOMATIC SOLID SHANK (ALLIANCE NO.2)
ELECTRIC (BR)
75
3.5
TUNGSTEN
54.5
NOT FITTED
NOT FITTED
NOT FITTED

ALTERNATIVES

TRACTION DATA FOR MULTIPLE UNITS

EMU- EUSTON-BIRMINGHAM-MANCHESTER & LIVERPOOL
VOLTAGE 25 KV A.C. OVERHEAD
TRACTION MOTORS 4 X 207 HP D.C. A.E.I.

BASIC TYPE

ED 215 0A

VARIANTS

NONE

MOTOR BRAKE SECOND

CLASS 302
305/2
308/1

MBS

ED 216

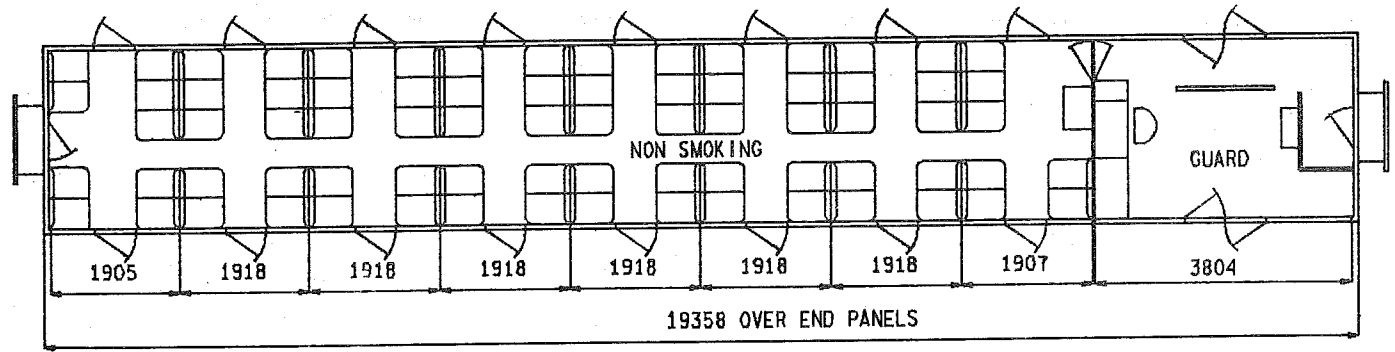
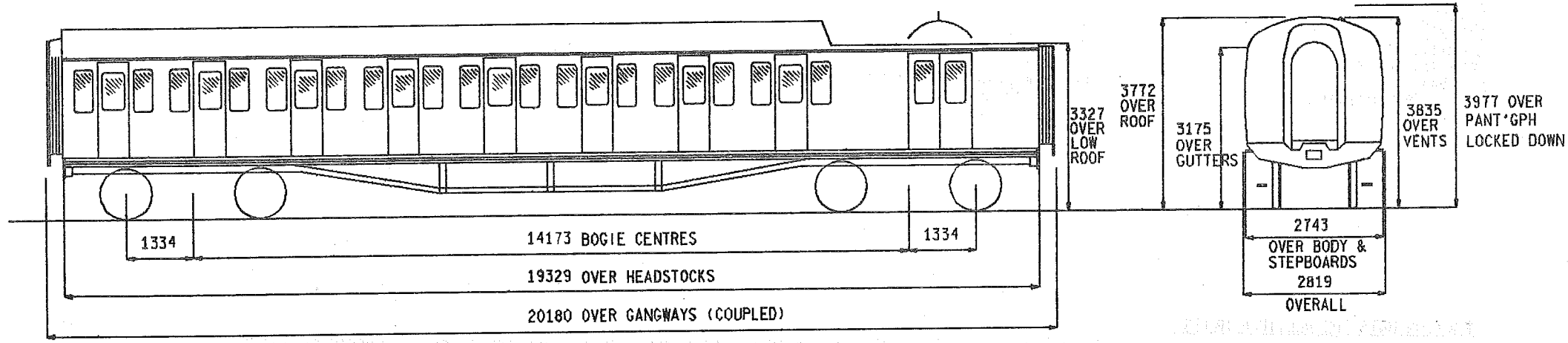

SEATS	76
TOILETS	-
COMPARTMENTS	-
GUARDS COMPARTMENTS	1
VENTILATION	-
CATERING EQUIPMENT	-

ISSUE 2 DATE AUG '83

BRAKES
 BOGIE/SUSPENSION
 BODY CONSTRUCTION
 COUPLINGS
 TRAIN HEATING
 MAX. SPEED M.P.H.
 MIN. RAD. CURVE CHAINS
 LIGHTING
 TARE WEIGHT TONNES
 GANGWAYS
 TRAIN COMMUNICATION
 BUFFERS

BASIC TYPE

ELECTRO PNEUMATIC
 GRESLEY ED5
 STEEL
 AUTOMATIC SOLID SHANK (ALLIANCE NO 2)
 ELECTRIC (BR)
 75
 3.5
 FLUORESCENT
 55 (EST)
 PULLMAN WITH RIGID (GRP) INNER PANELS
 PUBLIC ADDRESS
 CENTRE

ALTERNATIVES

GRESLEY ED8, GRESLEY ED2

TRACTION DATA FOR MULTIPLE UNITS

EMU- GREAT EASTERN OUTER SUBURBAN. INTRODUCED CLASS 302 1958, CLASS 305/2 1960, CLASS 308/1 1961. REFURBISHED 1983.
 VOLTAGE 25 & 6.25 KV A.C. OVERHEAD
 TRACTION MOTORS CLASS 302 - 4 x 192 HP D.C. ENGLISH ELECTRIC. CLASS 305/2 - 4 x 205 HP GEC. CLASS 308/1 - 4 x 232 HP D.C. ENGLISH ELECTRIC.

BASIC TYPE

ED 216 0A-REFURBISHED

VARIANTS

1B CLASS 308/1 GRESLEY ED8 BOGIES.
 2C CLASS 302 GRESLEY ED2 BOGIES.

MOTOR BRAKE SECOND

CLASS 302

MBS

ED 217

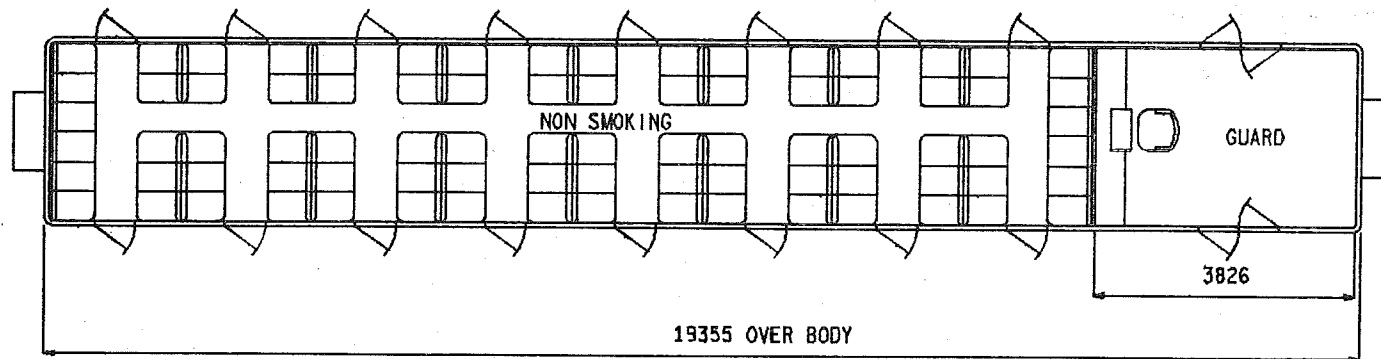
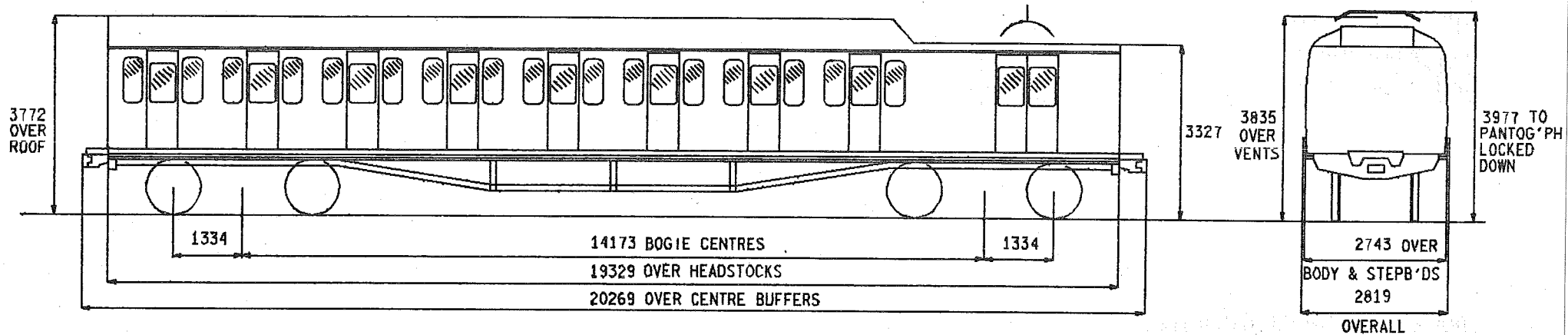

SEATS	82
TOILETS	-
COMPARTMENTS	-
GUARDS COMPARTMENTS	1
VENTILATION	-
CATERING EQUIPMENT	-

ORIGINAL DIAGRAMS FOR REFERENCE:-
BR 405

ISSUE 1 DATE AUG '83

BASIC TYPE

ALTERNATIVES

BRAKES
BOGIE/SUSPENSION
BODY CONSTRUCTION
COUPLINGS
TRAIN HEATING
MAX. SPEED M.P.H.
MIN. RAD. CURVE CHAINS
LIGHTING
TARE WEIGHT TONNES
GANGWAYS
TRAIN COMMUNICATION
BUFFERS

ELECTRO PNEUMATIC
GRESLEY ED2
STEEL
AUTOMATIC SOLID SHANK (ALLIANCE NO.2)
ELECTRIC (BR)
75
3.5
TUNGSTEN
55
NOT FITTED
NOT FITTED
NOT FITTED

TRACTION DATA FOR MULTIPLE UNITS

EMU- FENCHURCH ST.- SHOEBURYNESS. INTRODUCED 1958.
VOLTAGE 25 & 6.25 KV A.C. OVERHEAD
TRACTION MOTORS 4 X 192 HP D.C. ENGLISH ELECTRIC.

BASIC TYPE

ED 217 OA-TEMPORARILY REFURBISHED

VARIANTS

NONE

MOTOR BRAKE SECOND

CLASS 309/2
309/3

MBS

ED 218

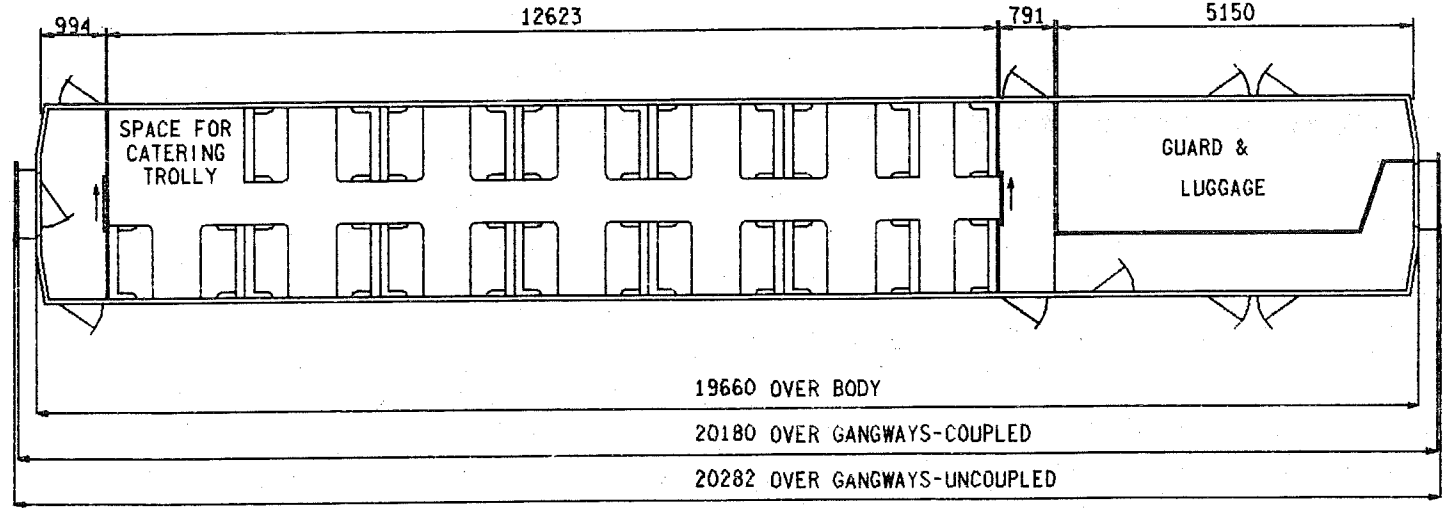
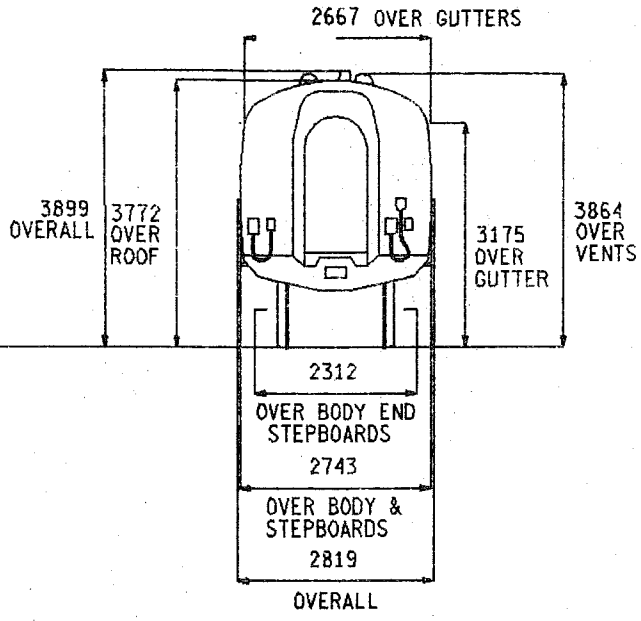
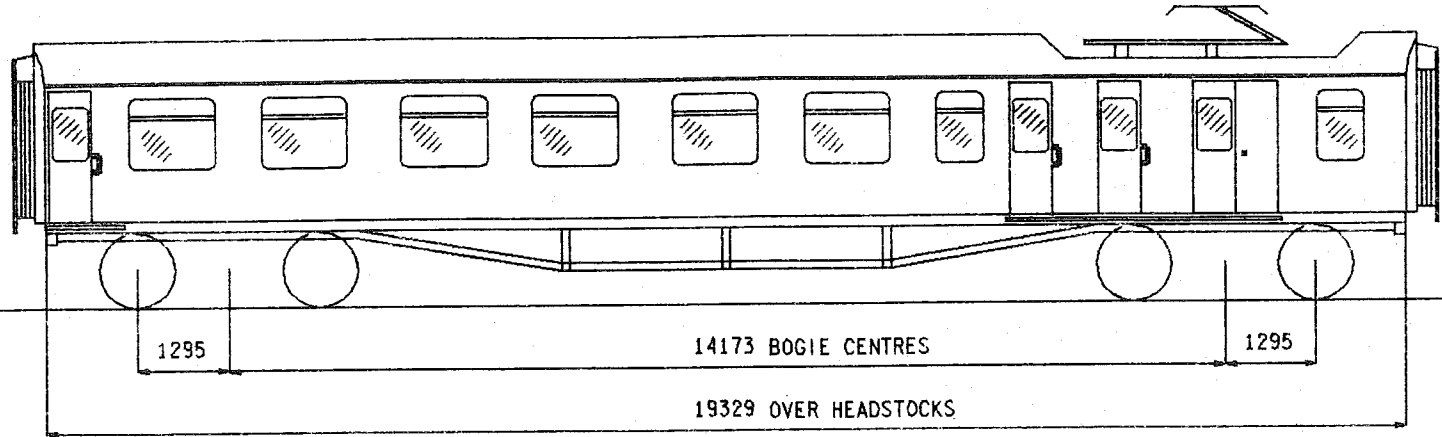

SEATS	48
TOILETS	-
COMPARTMENTS	-
GUARDS COMPARTMENTS	1
VENTILATION	-
CATERING EQUIPMENT	TROLLEY

ISSUE 2 DATE MAR 87

ED 218

BRAKES
BOGIE/SUSPENSION
BODY CONSTRUCTION
COUPLINGS
TRAIN HEATING
MAX.SPEED M.P.H.
MIN.RAD.CURVE CHAINS
LIGHTING
TARE WEIGHT TONNES
GANGWAYS
TRAIN COMMUNICATION
BUFFERS

BASIC TYPE

ELECTRO PNEUMATIC
COMMONWEALTH(POWERED)
STEEL
AUTOMATIC SOLID SHANK(ALLIANCE NO.2)
ELECTRIC(BR)
100
3.5
FLUORESCENT
57
PULLMAN
PUBLIC ADDRESS
NOT FITTED

ALTERNATIVES

TRACTION DATA FOR MULTIPLE UNITS

EMU- LIVERPOOL ST.-CLACTON & WALTON INTRODUCED 1962, REFURBISHED 1985.
VOLTAGE 25 & 6.25 KV A.C.OVERHEAD.
TRACTION MOTORS 4 x 282 HP D.C.GEC

BASIC TYPE

ED 218 0A

VARIANTS

NONE

MOTOR BRAKE STANDARD

CLASS 310/0
CLASS 310/1

MBS

ED 219

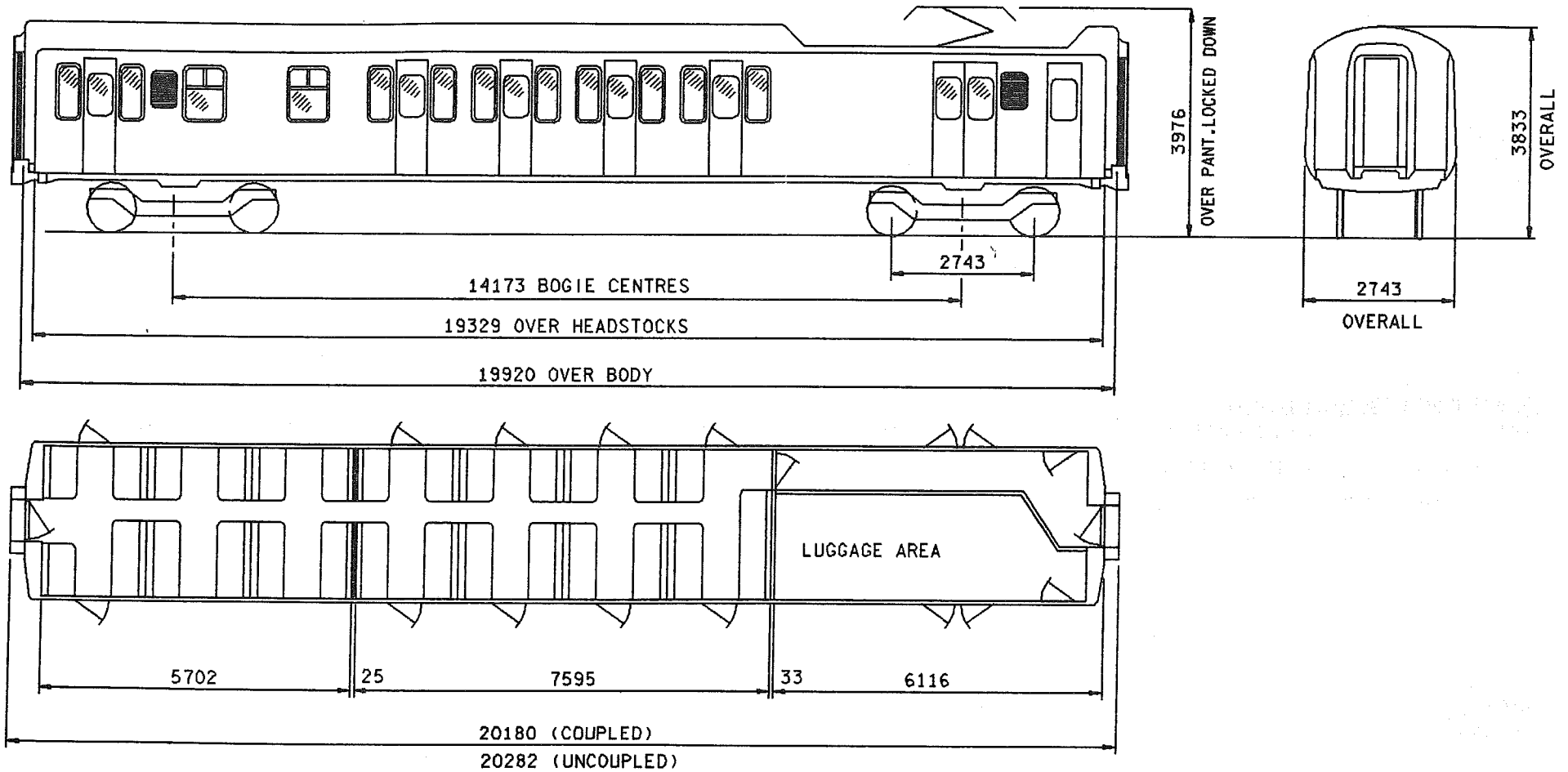

SEATS	68
TOILETS	-
COMPARTMENTS	-
GUARDS COMPARTMENTS	1
VENTILATION	-
CATERING EQUIPMENT	-

ISSUE DATE
1 AUG '88

ED 219

BRAKES
BOGIE/SUSPENSION
BODY CONSTRUCTION
COUPLINGS
TRAIN HEATING
MAX.SPEED M.P.H.
MIN.RAD.CURVE CHAINS
LIGHTING
TARE WEIGHT TONNES
GANGWAYS
TRAIN COMMUNICATION
BUFFERS

BASIC TYPE

ELECTRO PNEUMATIC
B4/AM10
STEEL
AUTOMATIC SOLID SHANK(BUCKEYE)
ELECTRIC(BR)
75
3.5
ELECTRIC
57
EXPRESS ELECTRIC
PUBLIC ADDRESS WITH TRANSMITTER
NOT FITTED

ALTERNATIVES

TRACTION DATA FOR MULTIPLE UNITS

EMU- EUSTON-BIRMINGHAM-MANCHESTER & LIVERPOOL INTRODUCED 1966, FACELIFTED 1985.
VOLTAGE 25 KV A.C.OVERHEAD.
TRACTION MOTORS 4 x 270 HP D.C.ENGLISH ELECTRIC

BASIC TYPE

ED 219 0A

VARIANTS

1B REFURBISHED & RECLASSIFIED CLASS 310/1

MOTOR BRAKE SECOND

CLASS 422/1
422/2
421/1
421/2

MBS

ED 260

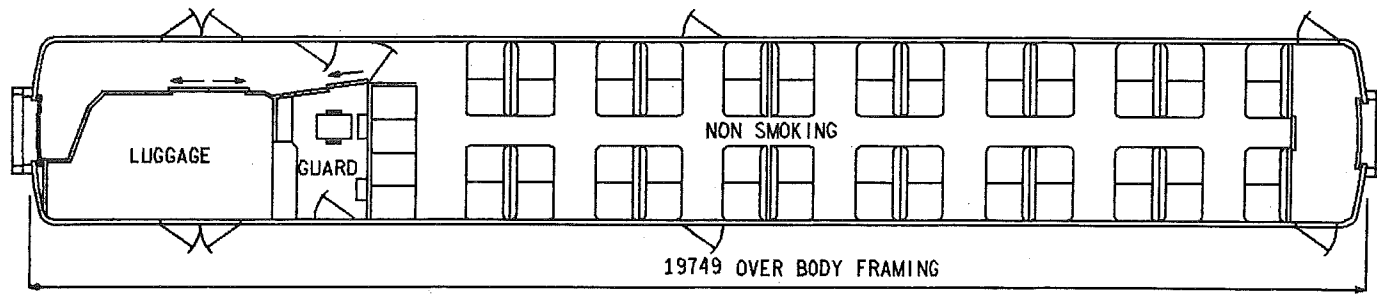
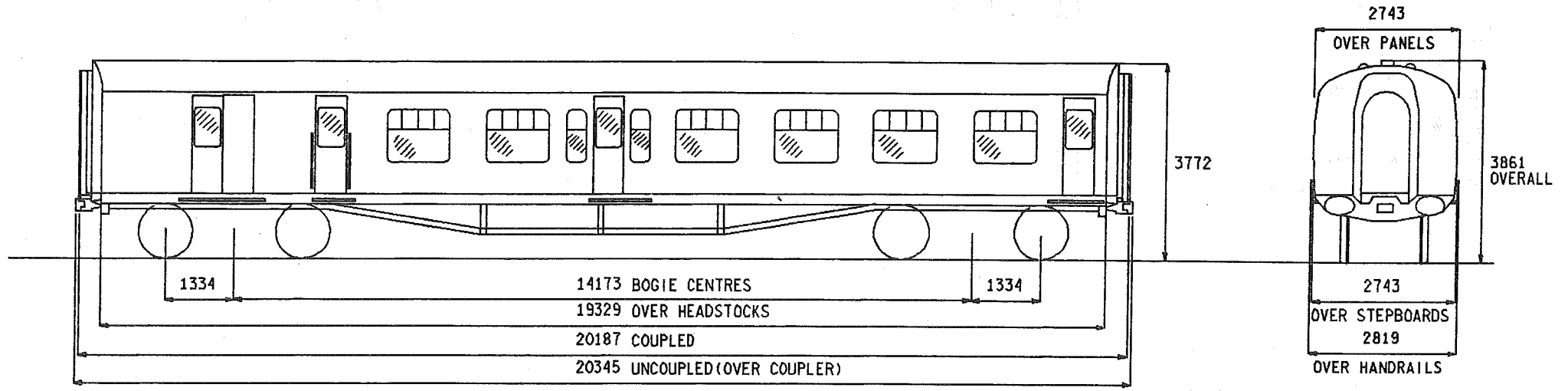

ALL WINDOWS ARE DOUBLE GLAZED.

SEATS	56
TOILETS	-
COMPARTMENTS	-
GUARDS COMPARTMENTS	1
VENTILATION	-
CATERING EQUIPMENT	-

ORIGINAL DIAGRAMS FOR REFERENCE:-
BR 423

ISSUE 4 DATE MAR 86

ED 260

BRAKES
BOGIE/SUSPENSION
BODY CONSTRUCTION
COUPLINGS
TRAIN HEATING
MAX.SPEED M.P.H.
MIN.RAD.CURVE CHAINS
LIGHTING
TARE WEIGHT TONNES
GANGWAYS
TRAIN COMMUNICATION
BUFFERS
S.R.DESIGN REFERENCE CODE

BASIC TYPE

ELECTRO PNEUMATIC
S.R.MK 4 POWERED
STEEL
AUTOMATIC SOLID SHANK (ALLIANCE NO.2)
ELECTRIC (BR)
90
3.5
TUNGSTEN
49
EXPRESS ELECTRIC
DRIVER/GUARD
NOT FITTED
EA

ALTERNATIVES

S.R.MK 6 POWERED

EA 1A, EA 2A

TRACTION DATA FOR MULTIPLE UNITS

EMU- INTRODUCED-CLASS 420/2 1970-CLASS 421/1 1964-CLASS 421/2 1970-CLASS 420 RECLASSIFIED 422 1984.
VOLTAGE 750/850 VOLTS D.C. THIRD RAIL
TRACTION MOTORS 4 X 250 HP ENGLISH ELECTRIC

BASIC TYPE

ED 260 0A

VARIANTS

1B S.R.MK 6 POWERED S.R.DESIGN REFERENCE CODE EA 1A.
2B S.R.MK 6 POWERED S.R.DESIGN REFERENCE CODE EA 2A.

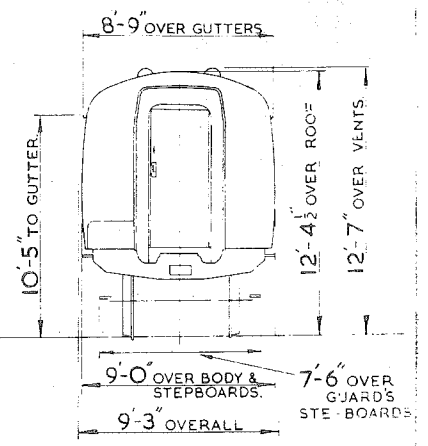
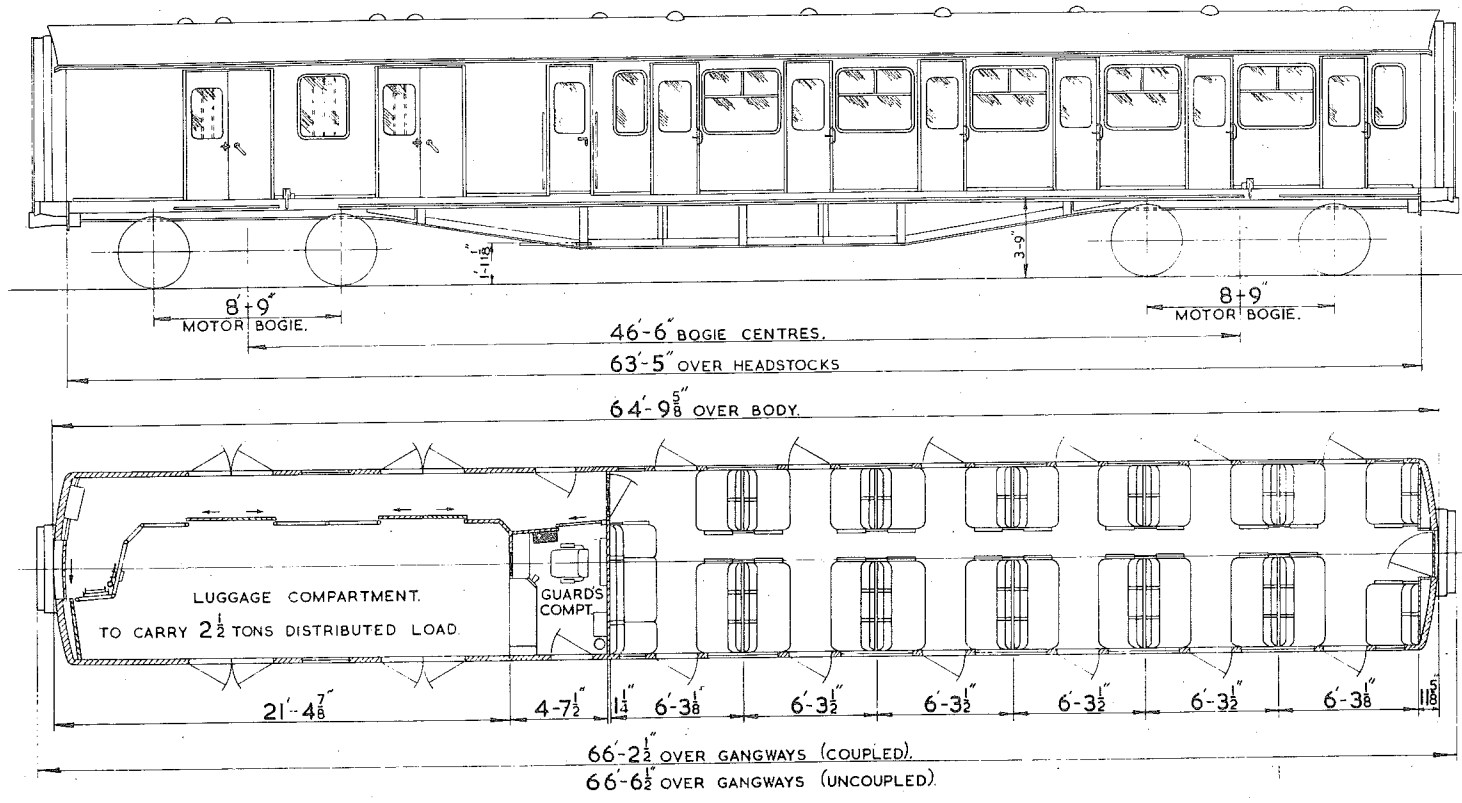

SEATS	58
TOILETS	-
COMPARTMENTS	-
GUARDS COMPARTMENTS	1
VENTILATION	-
CATERING EQUIPMENT	-

ORIGINAL DIAGRAMS FOR REFERENCE, -
BR 880

ISSUE 2 DATE MAY '81

ED 261

BASIC TYPE

BRAKES
BOGIE/SUSPENSION
BODY CONSTRUCTION
COUPLINGS
TRAIN HEATING
MAX. SPEED M.P.H.
MIN. RAD. CURVE CHAINS
LIGHTING
TARE WEIGHT TONNES
GANGWAYS
TRAIN COMMUNICATION
BUFFERS
S.R. DESIGN REFERENCE CODE

ELECTRO PNEUMATIC
S.R. MK 6 POWERED & UNPOWERED (ONE OF EACH)
STEEL
AUTOMATIC SOLID SHANK (ALLIANCE NO.2)
ELECTRIC (BR)
90
3.5
TUNGSTEN
49
EXPRESS ELECTRIC
DRIVER/GUARD
NOT FITTED
EB

ALTERNATIVES

EB 1A

TRACTION DATA FOR MULTIPLE UNITS

EMU- INTRODUCED 1967.
VOLTAGE 750/850 VOLTS D.C. THIRD RAIL
TRACTION MOTORS 4 X 250 HP ENGLISH ELECTRIC

BASIC TYPE

ED 261 0A

VARIANTS

1A S.R. DESIGN REFERENCE CODE EB 1A.

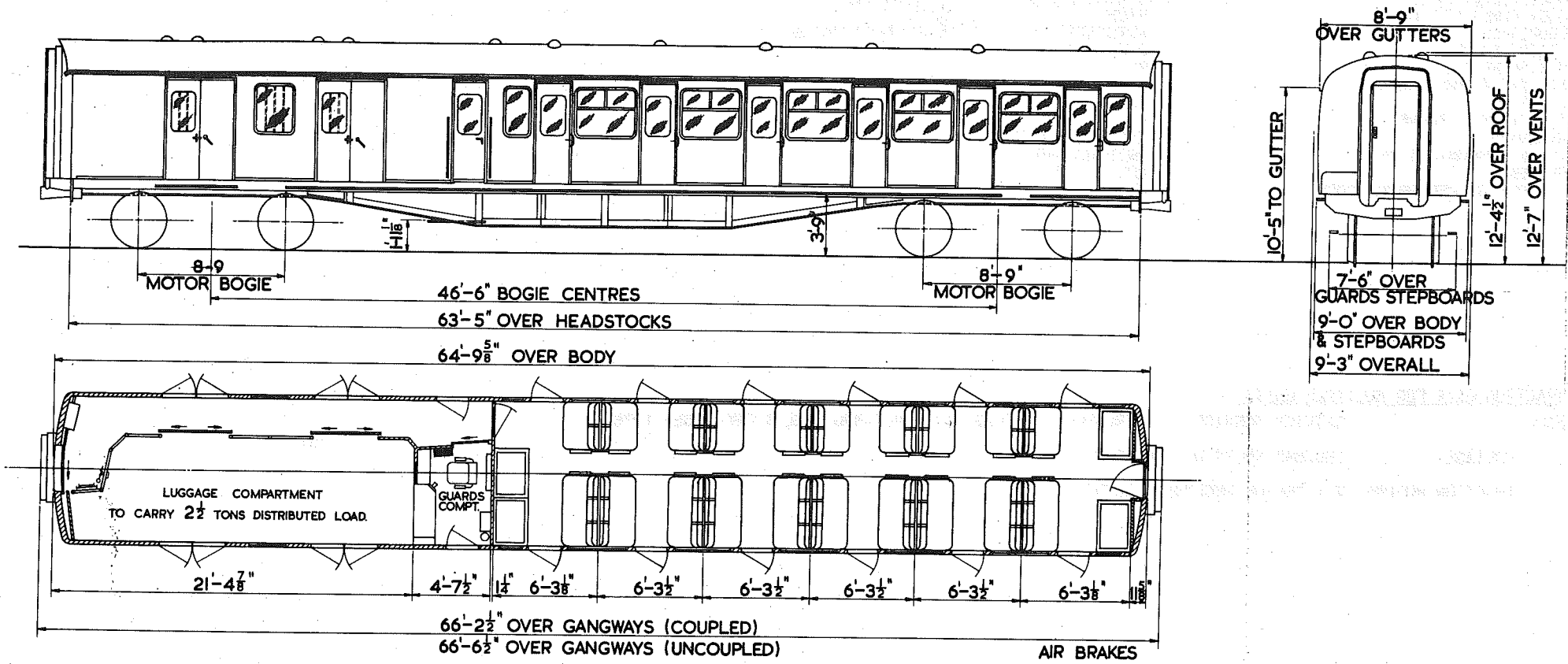

SEATS	50
TOILETS	-
COMPARTMENTS	-
GUARDS COMPARTMENTS	1
VENTILATION	-
CATERING EQUIPMENT	-

ORIGINAL DIAGRAMS FOR REFERENCE.--
BR 840

ISSUE 1 DATE SEP' 80

ED 262

BASIC TYPE

BRAKES
BOGIE/SUSPENSION
BODY CONSTRUCTION
COUPLINGS
TRAIN HEATING
MAX. SPEED H.P.H.
MIN. RAD. CURVE CHAINS
LIGHTING
TARE WEIGHT TONNES
GANGWAYS
TRAIN COMMUNICATION
BUFFERS
S.R. DESIGN REFERENCE CODE

ELECTRO PNEUMATIC
S.R. MK 6 POWERED & UNPOWERED (ONE OF EACH)
STEEL
AUTOMATIC SOLID SHANK (ALLIANCE NO.2)
ELECTRIC (BR)
90
3.5
ELECTRIC
49
EXPRESS ELECTRIC
DRIVER/GUARD
NOT FITTED
EB 2A

ALTERNATIVES

TRACTION DATA FOR MULTIPLE UNITS

EMU- GATWICK SERVICE INTRODUCED AS CLASS 423 1967-MODIFIED & RECLASSED 1978.
VOLTAGE 750/850 VOLTS D.C. THIRD RAIL
TRACTION MOTORS 2 X 250 HP ENGLISH ELECTRIC

BASIC TYPE

ED 262 0A

VARIANTS

NONE

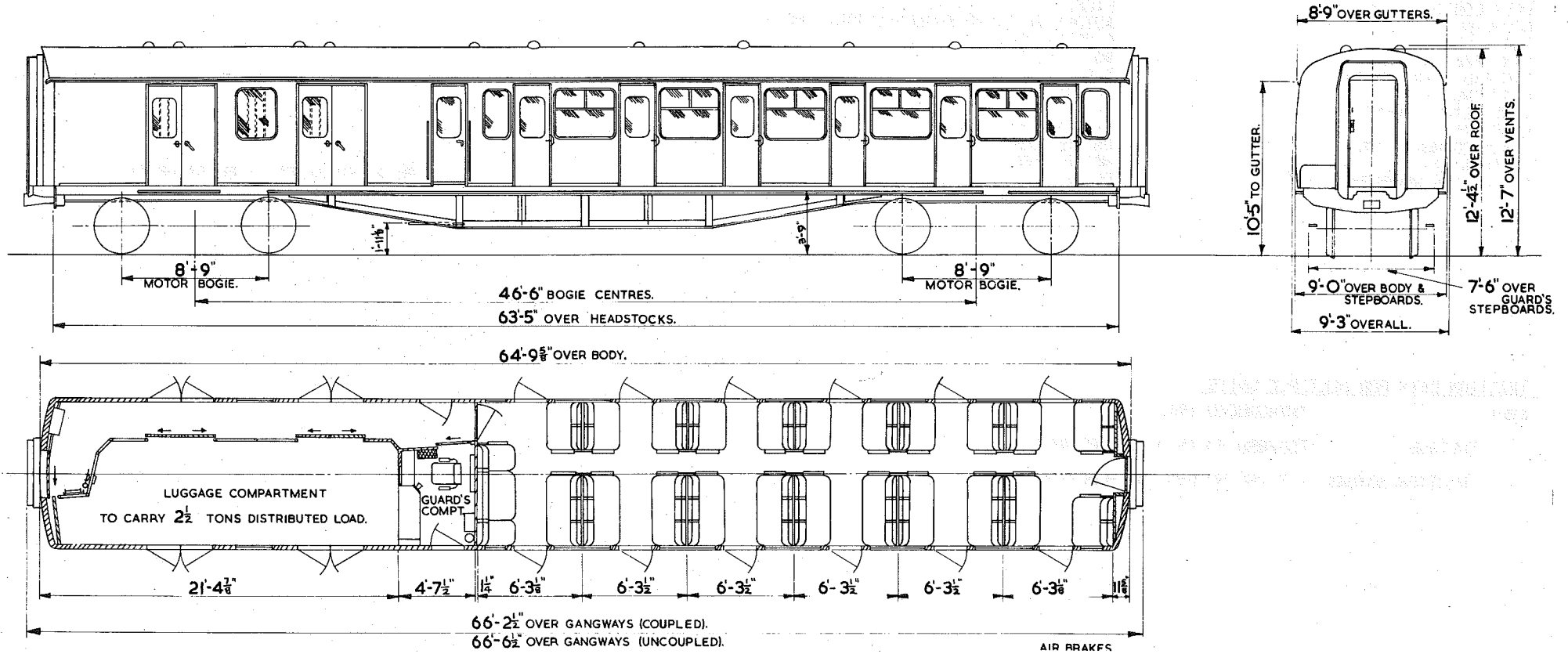

SEATS	58
TOILETS	-
COMPARTMENTS	-
GUARDS COMPARTMENTS	1
VENTILATION	-
CATERING EQUIPMENT	-

ORIGINAL DIAGRAMS FOR REFERENCE.-
BR 881

ISSUE 1 DATE SEP' 80

ED 263

BRAKES
BOGIE/SUSPENSION
BODY CONSTRUCTION
COUPLINGS
TRAIN HEATING
MAX. SPEED M.P.H.
MIN. RAD. CURVE CHAINS
LIGHTING
TARE WEIGHT TONNES
GANGWAYS
TRAIN COMMUNICATION
BUFFERS
S.R. DESIGN REFERENCE CODE

BASIC TYPE

ELECTRO PNEUMATIC
S.R. MK 6 POWERED & UNPOWERED (ONE OF EACH)
STEEL
AUTOMATIC SOLID SHANK (ALLIANCE NO. 2)
ELECTRIC (BR)
90
3.5
ELECTRIC
49
EXPRESS ELECTRIC
DRIVER/GUARD
NOT FITTED
EB 1A

ALTERNATIVES

BP8-F

EB 2A, EB 3A, EB 4A, EB 5A, EB 6A

TRACTION DATA FOR MULTIPLE UNITS

EMU- INTRODUCED 1967.
VOLTAGE 750/650 VOLTS D.C. THIRD RAIL
TRACTION MOTORS 4 X 250 HP ENGLISH ELECTRIC

BASIC TYPE

ED 263 0A

VARIANTS

1A S.R. DESIGN REFERENCE CODE EB 2A.
2A S.R. DESIGN REFERENCE CODE EB 3A.
3A S.R. DESIGN REFERENCE CODE EB 4A, BP8-F BOGIES.
4A S.R. DESIGN REFERENCE CODE EB 5A.
5A S.R. DESIGN REFERENCE CODE EB 6A.

MOTOR BUFFET LUGGAGE STANDARD

CLASS 442

MBLS

ED 265

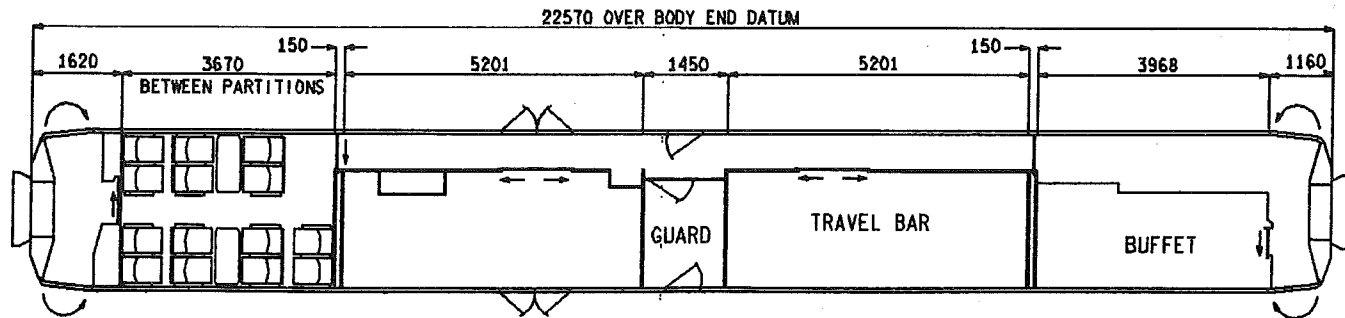
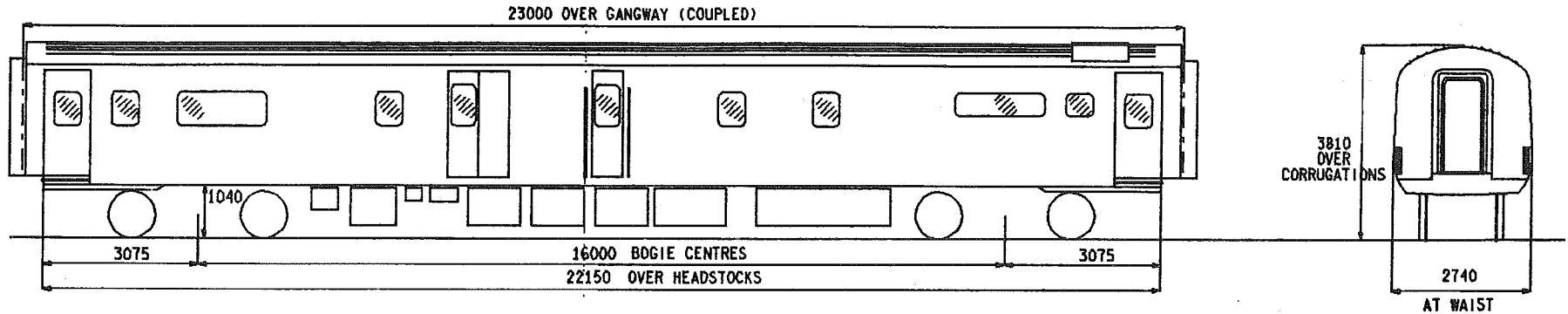

- | | |
|---------------------|-----------------------|
| SEATS | 14 |
| TOILETS | - |
| COMPARTMENTS | - |
| GUARDS COMPARTMENTS | 1 |
| VENTILATION | FULL AIR CONDITIONING |
| CATERING EQUIPMENT | MICROWAVE |

ISSUE 1 DATE JUL 88

ED 265

BRAKES
BOGIE/SUSPENSION
BODY CONSTRUCTION
COUPLINGS
TRAIN HEATING

MAX.SPEED M.P.H.
MIN.RAD.CURVE METRES
LIGHTING
TARE WEIGHT TONNES
GANGWAYS

BUFFERS

TRAIN COMMUNICATION

BASIC TYPE

ELECTRO-PNEUMATIC
P7-3 (BREL)
STEEL
BAR
ELECTRIC(BR) FULL AIR CONDITIONING

100
90
FLUORESCENT
51
CENTRALLY SUPPORTED-SWIVELLING-FLEXIBLE DIAPHRAGM-STEEL FACE PLATE

NOT FITTED

PUBLIC ADDRESS WITH TRANSMITTER

ALTERNATIVES

TRACTION DATA FOR MULTIPLE UNITS

EMU- WATERLOO-BOURNEMOUTH-WEYMOUTH. INTRODUCED 1988
VOLTAGE 750 VOLTS D.C. THIRD RAIL

BASIC TYPE
ED 265 0A

VARIANTS
NONE

DRIVING TRAILER FIRST

CLASS 442

DTF

EE 160

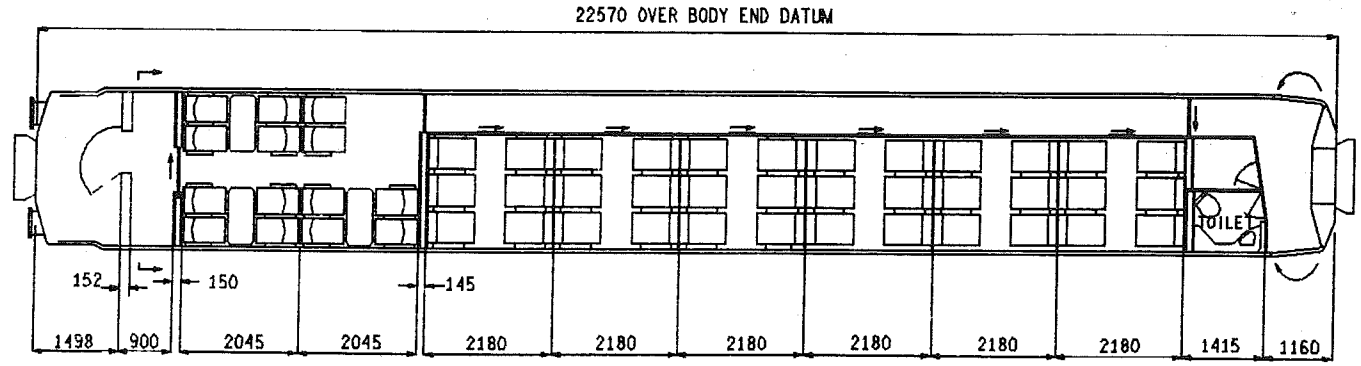
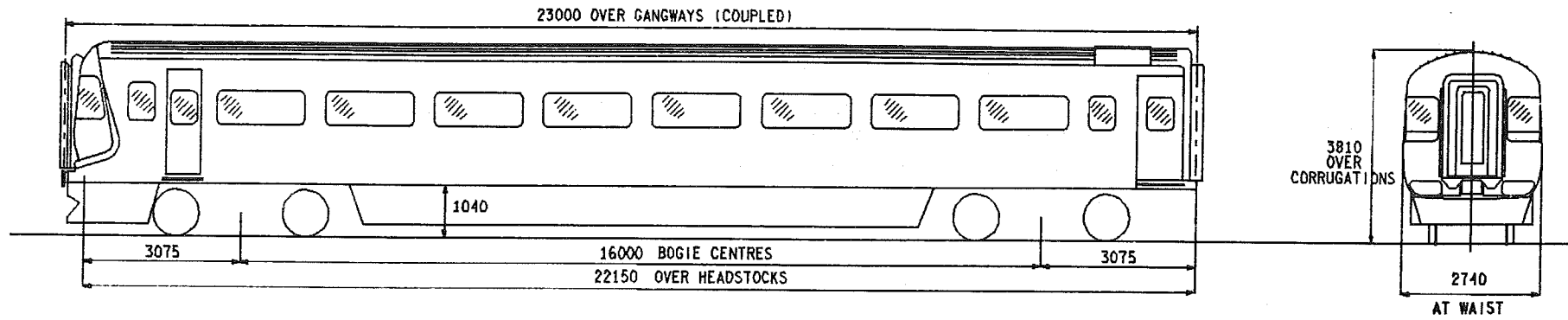

- | | |
|---------------------|-----------------------|
| SEATS | 50 |
| TOILETS | 1 |
| COMPARTMENTS | 6 |
| GUARDS COMPARTMENTS | - |
| VENTILATION | FULL AIR CONDITIONING |
| CATERING EQUIPMENT | - |

ISSUE	DATE
1	JUL 88

EE 160

BASIC TYPE

ALTERNATIVES

BRAKES
BOGIE/SUSPENSION
BODY CONSTRUCTION
COUPLINGS
TRAIN HEATING

ELECTRO-PNEUMATIC
T3-7 (BREL)
STEEL
AUTOMATIC DROPHEAD BUCKEYE OUTER END- BAR INNER END
ELECTRIC(BR) FULL AIR CONDITIONING

MAX. SPEED M.P.H.
MIN. RAD. CURVE METRES
LIGHTING
TARE WEIGHT TONNES
GANGWAYS
TRAIN COMMUNICATION

100
90
FLUORESCENT
34
CENTRALLY SUPPORTED-SWIVELLING-FLEXIBLE DIAPHRAGM-STEEL FACE PLATE
DRIVER/SIGNAL BOX-DRIVER/GUARD-PUBLIC ADDRESS WITH TRANSMITTER

BUFFERS
A.W.S.

RETRACTABLE SPINDLE- OUTER END ONLY
FITTED

TRACTION DATA FOR MULTIPLE UNITS

EMU- WATERLOO-BOURNEMOUTH-WEYMOUTH. INTRODUCED 1988

VOLTAGE 750 VOLTS.D.C. THIRD RAIL

BASIC TYPE

EE 160 OA

VARIANTS

NONE



SEATS	66
TOILETS	-
COMPARTMENTS	-
GUARDS COMPARTMENTS	-
VENTILATION	-
CATERING EQUIPMENT	-

ORIGINAL DIAGRAMS FOR REFERENCE.-
LMS 392A

ISSUE 2 DATE MAY '81

EE 202

BASIC TYPE

ALTERNATIVES

BRAKES
BOGIE/SUSPENSION
BODY CONSTRUCTION
COUPLINGS

TRAIN HEATING
MAX. SPEED M.P.H.
MIN. RAD. CURVE CHAINS
LIGHTING
TARE WEIGHT TONNES
GANGWAYS
A.V.S.
TRAIN COMMUNICATION
BUFFERS

ELECTRO PNEUMATIC
CLASS 503 TRAILER
STEEL
AUTOMATIC SOLID SHANK (ALLIANCE NO.2) OUTER END-PERMANENT SCREW
INNER END
ELECTRIC (BR)
65
3.5
TUNGSTEN
22.5
NOT FITTED
NOT FITTED
NOT FITTED
SPINDLE-457 DIA.-INNER END ONLY

TRACTION DATA FOR MULTIPLE UNITS

EMU- WIRRAL & MERSEY. INTRODUCED 1938 & 1956.
VOLTAGE 650 VOLTS D.C. THIRD RAIL

BASIC TYPE

EE 202 0A

VARIANTS

NONE

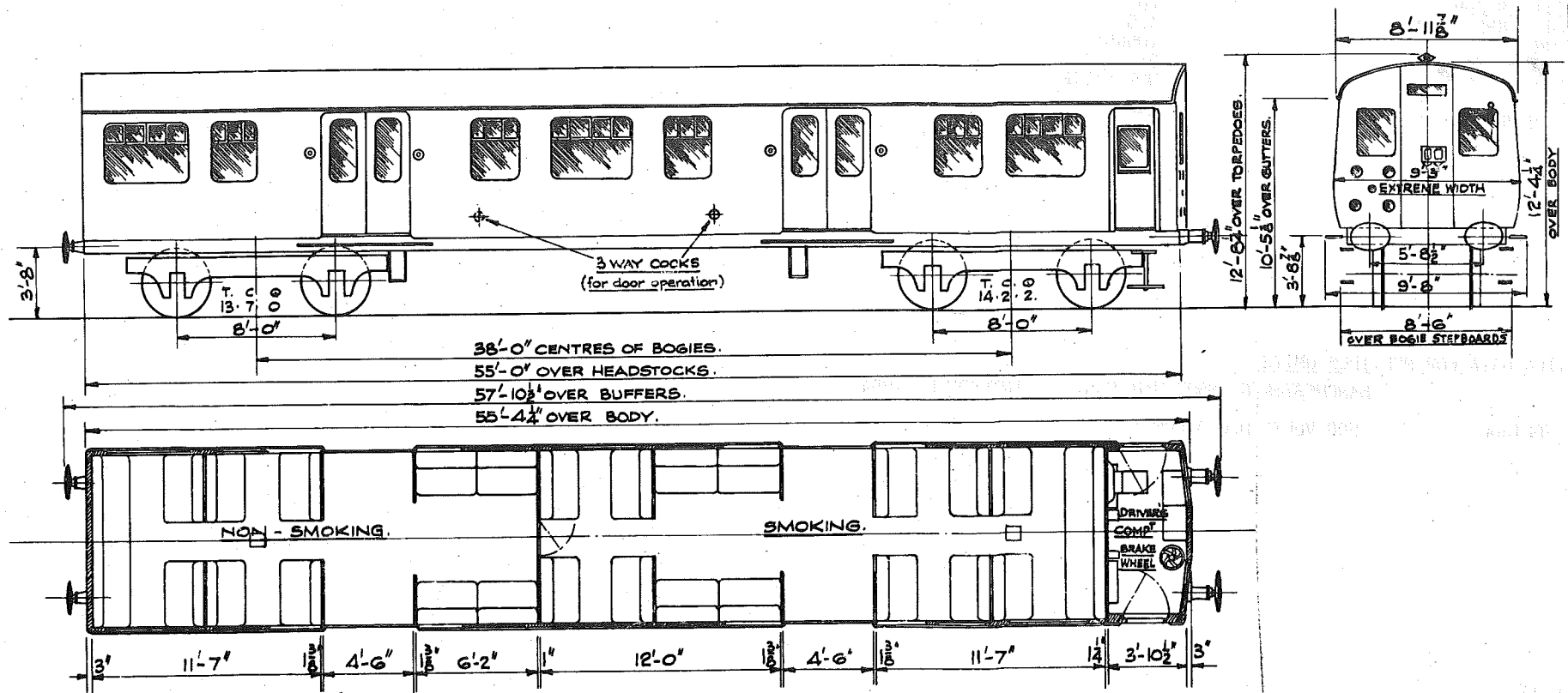

SEATS	60
TOILETS	-
COMPARTMENTS	-
GUARDS COMPARTMENTS	-
VENTILATION	-
CATERING EQUIPMENT	-

ORIGINAL DIAGRAMS FOR REFERENCE.-
LNE 365

ISSUE 2 DATE MAY '81

EE 204

BASIC TYPE

ALTERNATIVES

BRAKES
BOGIE/SUSPENSION
BODY CONSTRUCTION
COUPLINGS
TRAIN HEATING
MAX. SPEED M.P.H.
MIN. RAD. CURVE CHAINS
LIGHTING
TARE WEIGHT TONNES
GANGWAYS
A. W. S.
TRAIN COMMUNICATION
BUFFERS

ELECTRO PNEUMATIC
CLASS 506 TRAILER
STEEL
SCREW
ELECTRIC (BR)
70
3.5
TUNGSTEN
28
NOT FITTED
NOT FITTED
NOT FITTED
SELF CONTAINED-559 OVAL

TRACTION DATA FOR MULTIPLE UNITS

EMU- MANCHESTER-GLOSSOP-HADFIELD. INTRODUCED 1954.
VOLTAGE 1500 VOLTS D.C. OVERHEAD

BASIC TYPE

EE 204 0A

VARIANTS

NONE

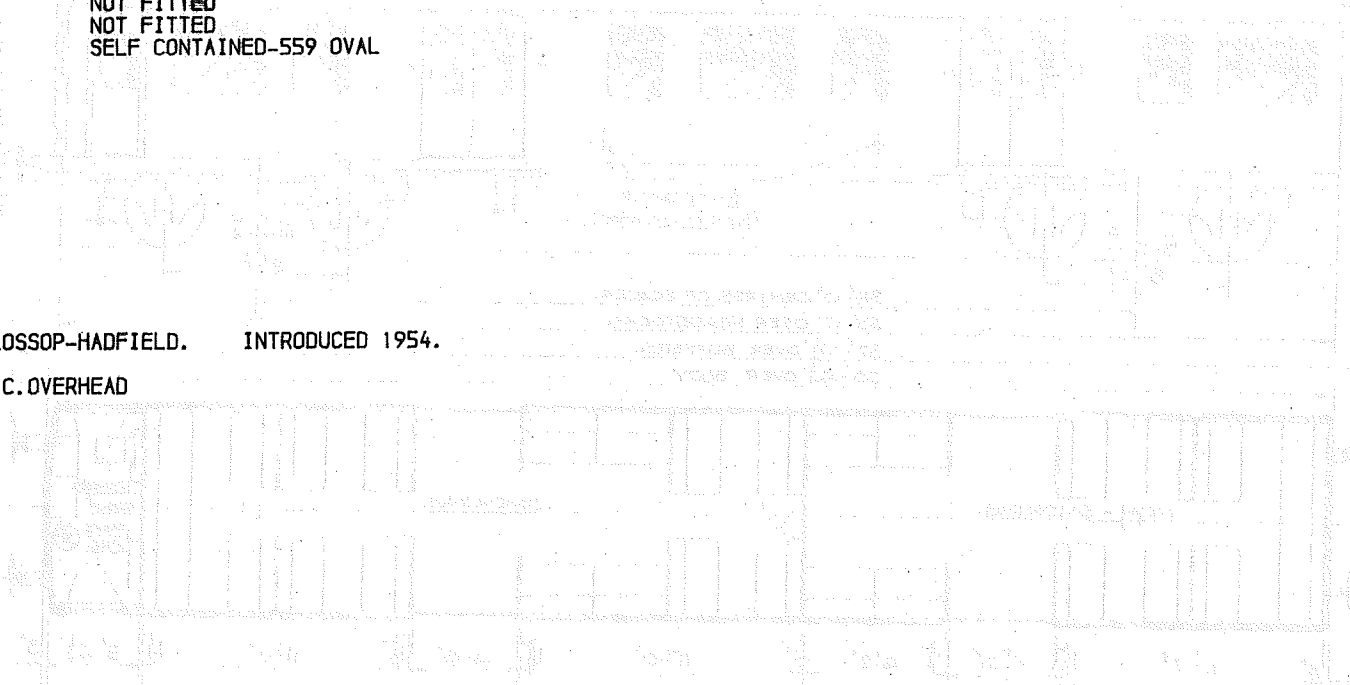

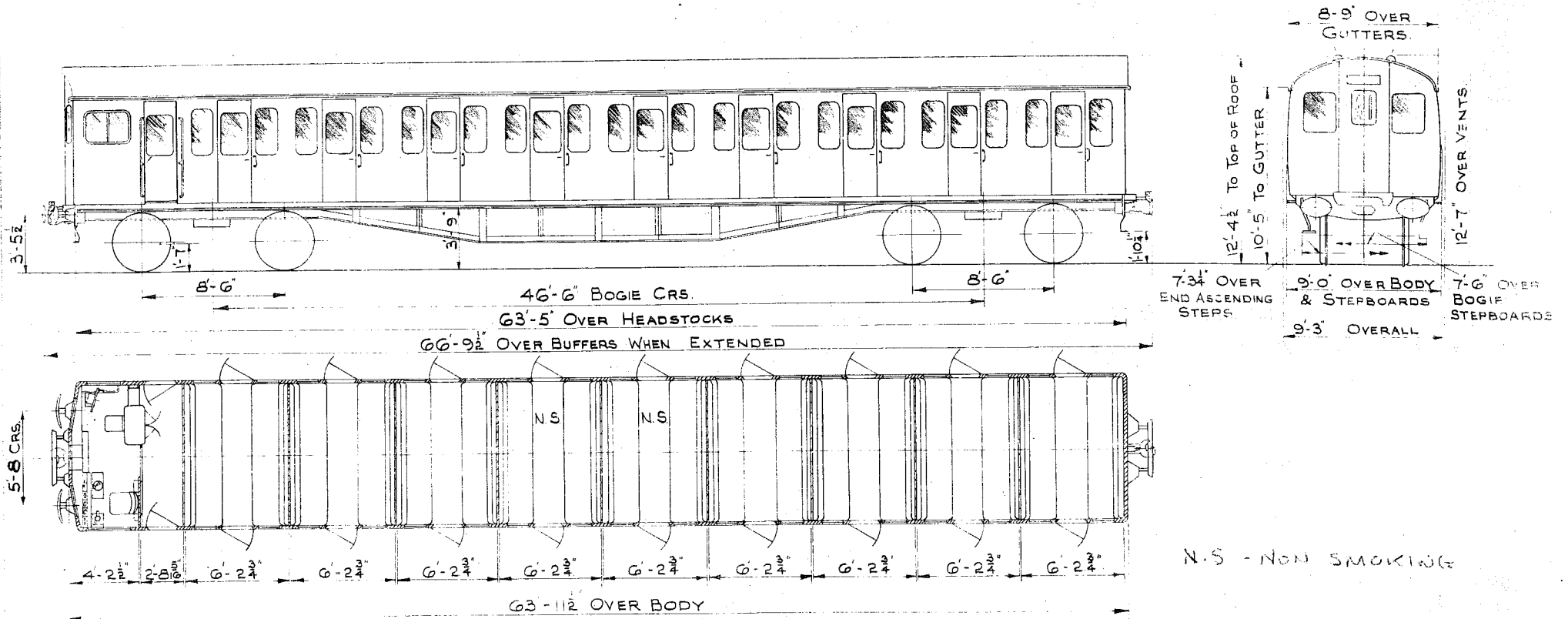

SEATS	108
TOILETS	-
COMPARTMENTS	9
GUARDS COMPARTMENTS	-
VENTILATION	-
CATERING EQUIPMENT	-

ORIGINAL DIAGRAMS FOR REFERENCE:-
BR 433

ISSUE 2 DATE MAR 87

EE 205

BRAKES
BOGIE/SUSPENSION
BODY CONSTRUCTION
COUPLINGS

TRAIN HEATING
MAX. SPEED M.P.H.
MIN. RAD. CURVE CHAINS
LIGHTING
TARE WEIGHT TONNES
GANGWAYS
A.W.S.
TRAIN COMMUNICATION
BUFFERS

BASIC TYPE

ELECTRO PNEUMATIC
GRESLEY ET2
STEEL
AUTOMATIC DROPHEAD(BUCKEYE) OUTER END - AUTOMATIC SOLID SHANK
(ALLIANCE NO.2) INNER END
ELECTRIC(BR)
75
3.5
TUNGSTEN
32.5
NOT FITTED
FITTED
NOT FITTED
RETRACTABLE SPINDLE-559 X 356 OVAL OUTER END ONLY

ALTERNATIVES

B4

TRACTION DATA FOR MULTIPLE UNITS

EMU- FENCHURCH ST.-SHOEBURYNESS. INTRODUCED 1958.
VOLTAGE 25 & 6.25 KV A.C.OVERHEAD

BASIC TYPE

EE 205 OA

VARIANTS

Ø B4 BOGIES.

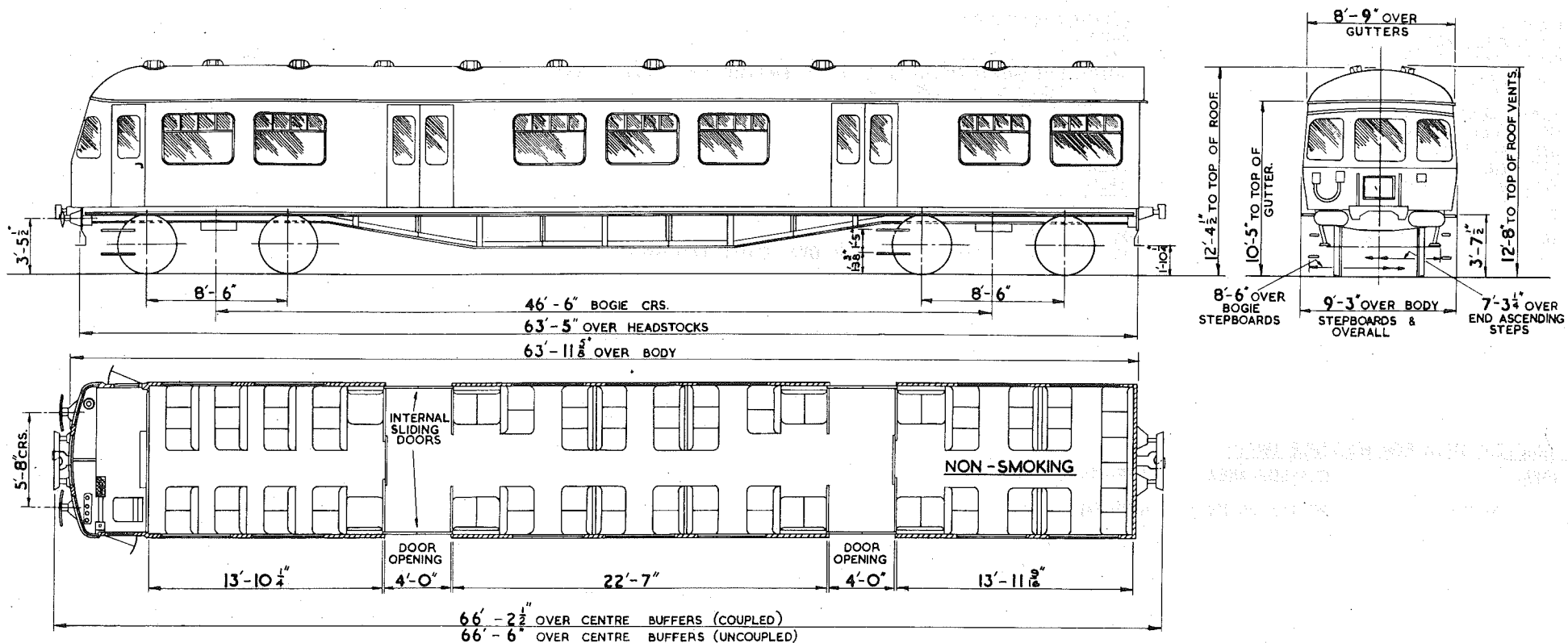

SEATS	83
TOILETS	-
COMPARTMENTS	-
GUARDS COMPARTMENTS	-
VENTILATION	-
CATERING EQUIPMENT	-

ORIGINAL DIAGRAMS FOR REFERENCE, -
BR 439

ISSUE 1 DATE SEP' 80

EE 206

BASIC TYPE

ALTERNATIVES

BRAKES
BOGIE/SUSPENSION
BODY CONSTRUCTION
COUPLINGS

ELECTRO PNEUMATIC
GRESLEY ET3 *DRG NO SCRS 875A*
STEEL
AUTOMATIC DROPHEAD (BUCKEYE) OUTER END-AUTOMATIC SOLID SHANK
(ALLIANCE NO.2) INNER END
ELECTRIC (BR)
75
3.5
ELECTRIC
34.5
NOT FITTED
FITTED
NOT FITTED
RETRACTABLE SPINDLE-559 X 356 OVAL OUTER END ONLY

TRAIN HEATING
MAX. SPEED M.P.H.
MIN. RAD. CURVE CHAINS
LIGHTING
TARE WEIGHT TONNES
GANGWAYS
A. V. S.
TRAIN COMMUNICATION
BUFFERS

TRACTION DATA FOR MULTIPLE UNITS

EMU- GLASGOW AREA. INTRODUCED 1960.
VOLTAGE 25 & 6.25 KV A.C. OVERHEAD

BASIC TYPE

EE 206 0A

VARIANTS

NONE

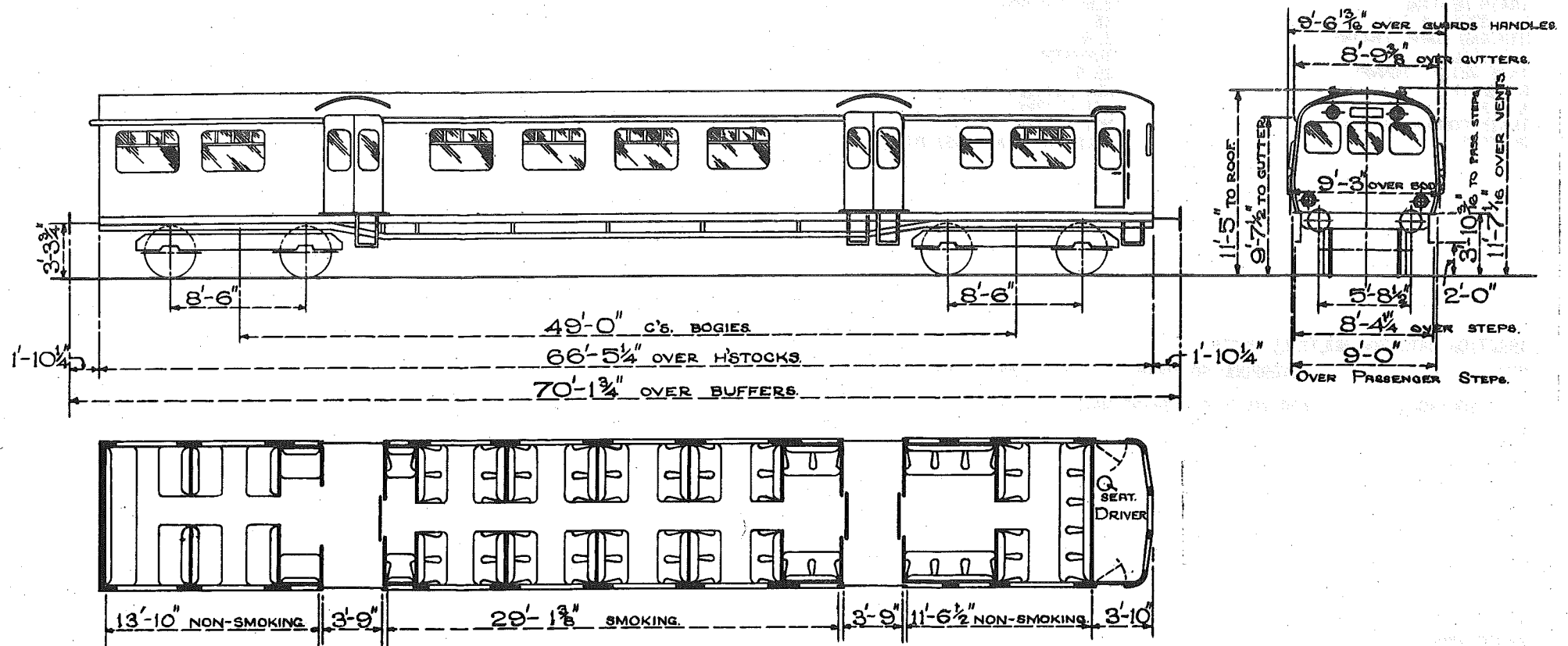

SEATS	78
TOILETS	-
COMPARTMENTS	-
GUARDS COMPARTMENTS	-
VENTILATION	-
CATERING EQUIPMENT	-

ORIGINAL DIAGRAMS FOR REFERENCE.-
LMS 393

ISSUE 2 DATE MAY '81

EE 207

BASIC TYPE

ALTERNATIVES

BRAKES
BOGIE/SUSPENSION
BODY CONSTRUCTION
COUPLINGS
TRAIN HEATING
MAX. SPEED H.P.H.
MIN. RAD. CURVE CHAINS
LIGHTING
TARE WEIGHT TONNES
GANGWAYS
A.V.S.
TRAIN COMMUNICATION
BUFFERS

ELECTRO PNEUMATIC
CLASS 502 TRAILER
STEEL
SCREW
ELECTRIC (BR)
65
3.5
TUNGSTEN
25.5
NOT FITTED
NOT FITTED
NOT FITTED
SELF CONTAINED-457 DIA.

TRACTION DATA FOR MULTIPLE UNITS

EMU- LIVERPOOL-SOUTHPORT. INTRODUCED 1939.
VOLTAGE 630 VOLTS D.C. THIRD RAIL

BASIC TYPE

EE 207 0A

VARIANTS

NONE

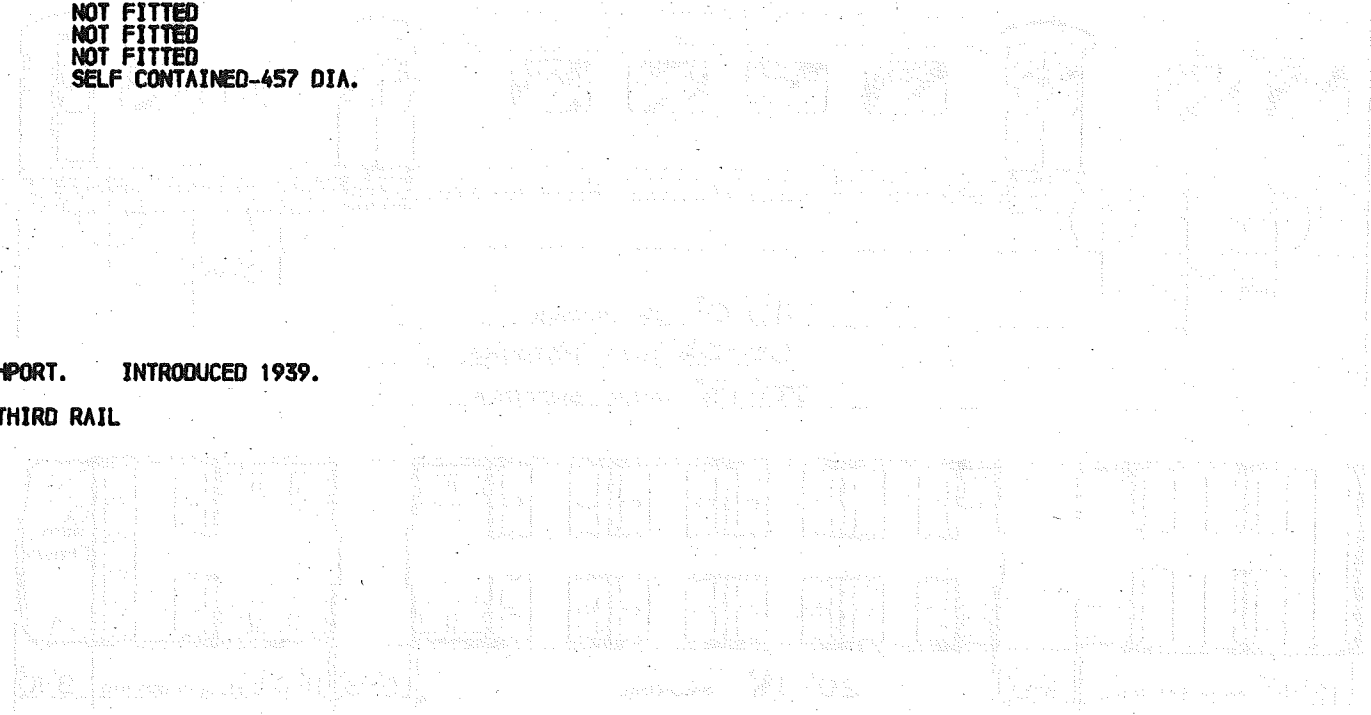

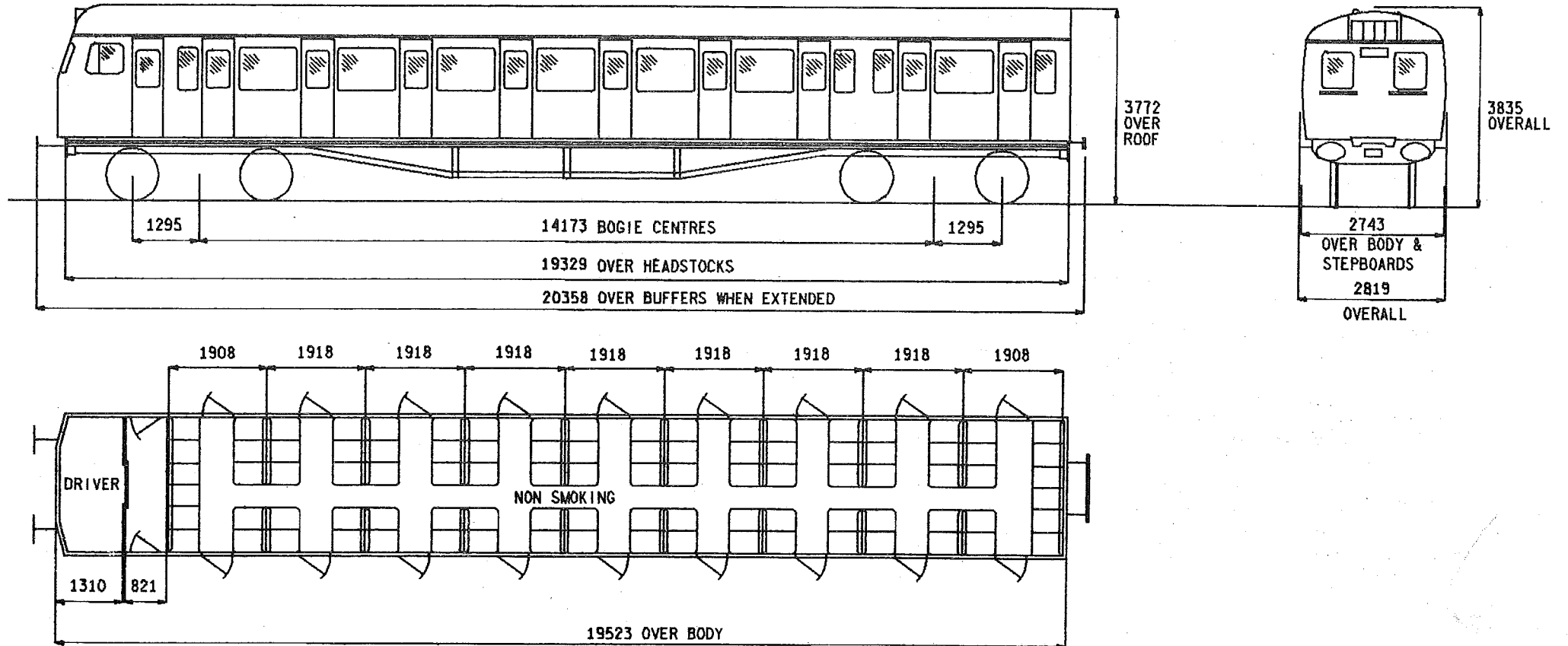

SEATS	92
TOILETS	-
COMPARTMENTS	-
GUARDS COMPARTMENTS	-
VENTILATION	-
CATERING EQUIPMENT	-

ORIGINAL DIAGRAMS FOR REFERENCE:-
BR 436

ISSUE 6 DATE AUG 87

EE 209

BRAKES
BOGIE/SUSPENSION
BODY CONSTRUCTION
COUPLINGS

TRAIN HEATING
MAX.SPEED M.P.H.
MIN.RAD.CURVE CHAINS
LIGHTING
TARE WEIGHT TONNES
GANGWAYS
A.W.S.
TRAIN COMMUNICATION
BUFFERS

BASIC TYPE

ELECTRO PNEUMATIC
GRESLEY ET8
STEEL
AUTOMATIC DROPHEAD(BUCKEYE) OUTER END-AUTOMATIC SOLID SHANK
(ALLIANCE NO.2) INNER END
ELECTRIC(BR)
75
3.5
FLUORESCENT & TUNGSTEN
31.5
NOT FITTED
FITTED
NOT FITTED
RETRACTABLE SPINDLE-559 X 356 OVAL OUTER END ONLY

ALTERNATIVES

GRESLEY ET5

PUBLIC ADDRESS

TRACTION DATA FOR MULTIPLE UNITS

EMU- LIVERPOOL ST.-ENFIELD-CHINGFORD. INTRODUCED-CLASS 305/1 1960-CLASS 308/3 1961.
VOLTAGE 25 & 6.25 KV A.C.OVERHEAD

BASIC TYPE

EE 209 0A

VARIANTS

0B GRESLEY ET5 BOGIES.
1C PUBLIC ADDRESS.
1D GRESLEY ET5 BOGIES,PUBLIC ADDRESS

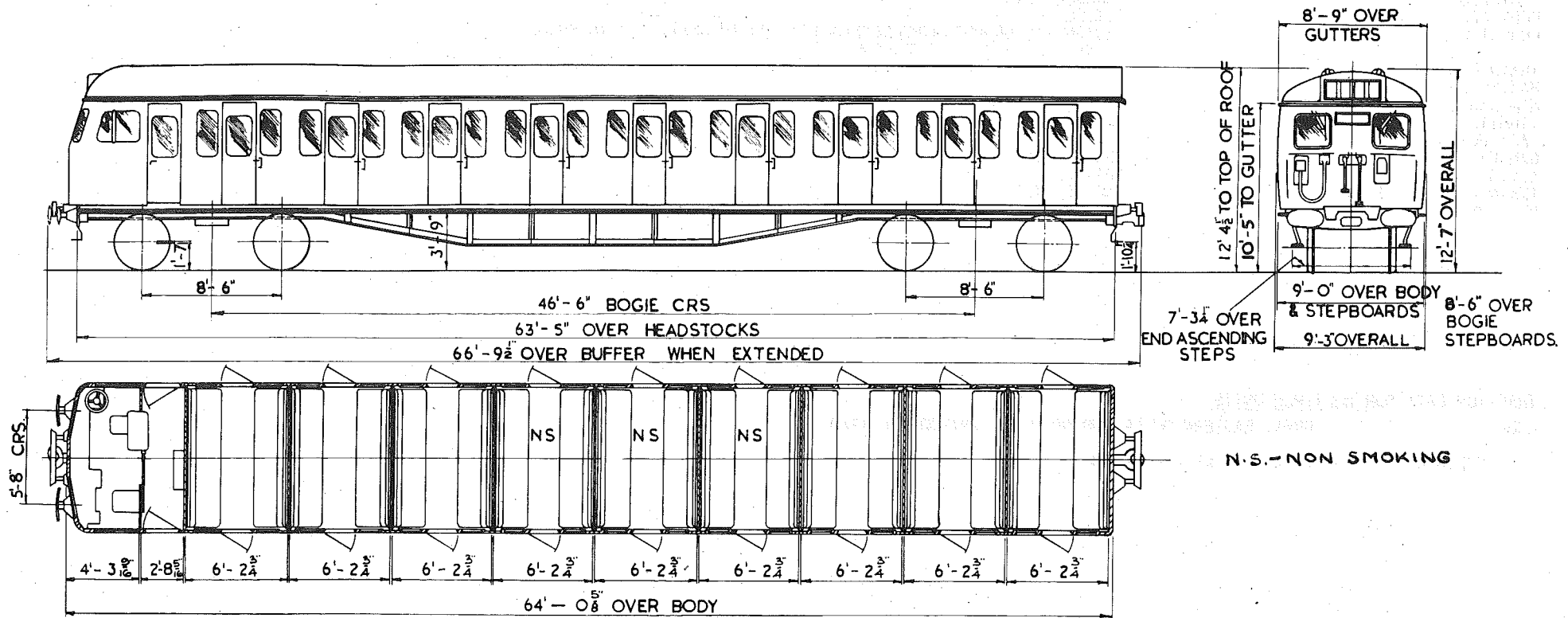

SEATS	108
TOILETS	-
COMPARTMENTS	-
GUARDS COMPARTMENTS	-
VENTILATION	-
CATERING EQUIPMENT	-

ORIGINAL DIAGRAMS FOR REFERENCE, -
BR 437

ISSUE 1 DATE SEP' 80

EE 210

BRAKES
BOGIE/SUSPENSION
BODY CONSTRUCTION
COUPLINGS

TRAIN HEATING
MAX. SPEED M.P.H.
MIN. RAD. CURVE CHAINS
LIGHTING
TARE WEIGHT TONNES
GANGWAYS
A.V.S.
TRAIN COMMUNICATION
BUFFERS

BASIC TYPE

ELECTRO PNEUMATIC
GRESLEY ETS
STEEL
AUTOMATIC DROPHEAD (BUCKEYE) OUTER END-AUTOMATIC SOLID SHANK
(ALLIANCE NO. 2) INNER END
ELECTRIC (BR)
75
3.5
ELECTRIC
32.5
NOT FITTED
FITTED
NOT FITTED
RETRACTABLE SPINDLE-559 X 356 OVAL OUTER END ONLY

ALTERNATIVES

TRACTION DATA FOR MULTIPLE UNITS

EMU- GREAT EASTERN OUTER SUBURBAN. INTRODUCED 1960.
VOLTAGE 25 & 6.25 KV A.C. OVERHEAD

BASIC TYPE

EE 210 0A

VARIANTS

NONE

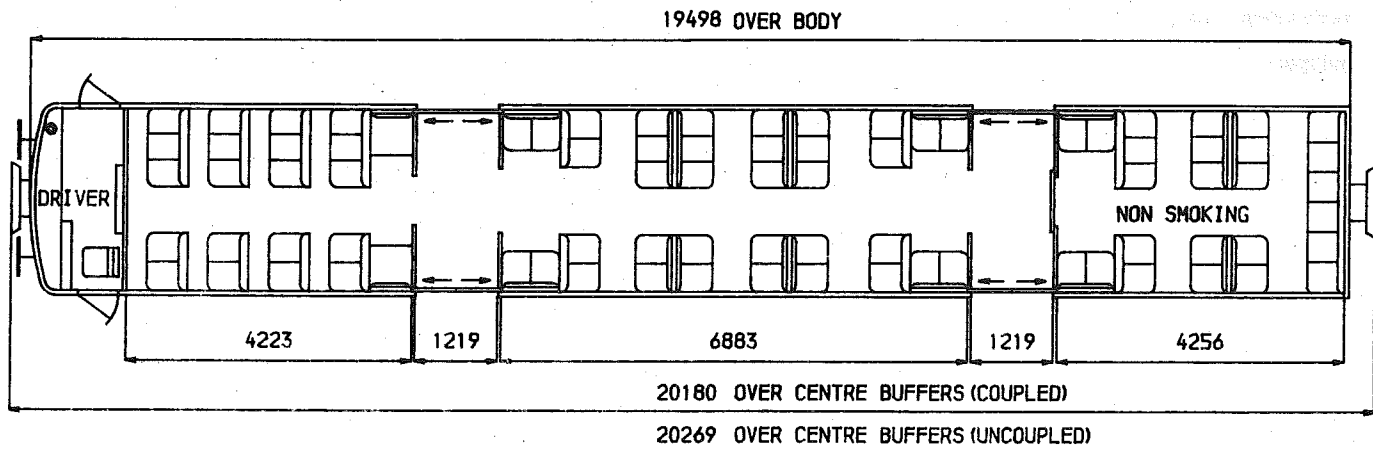
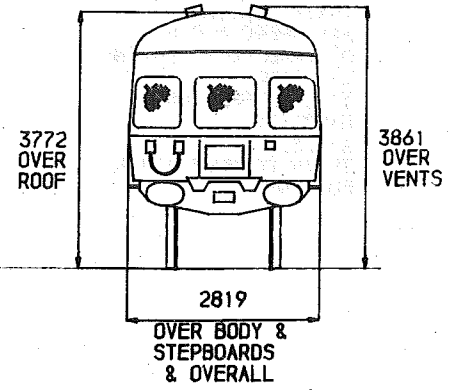
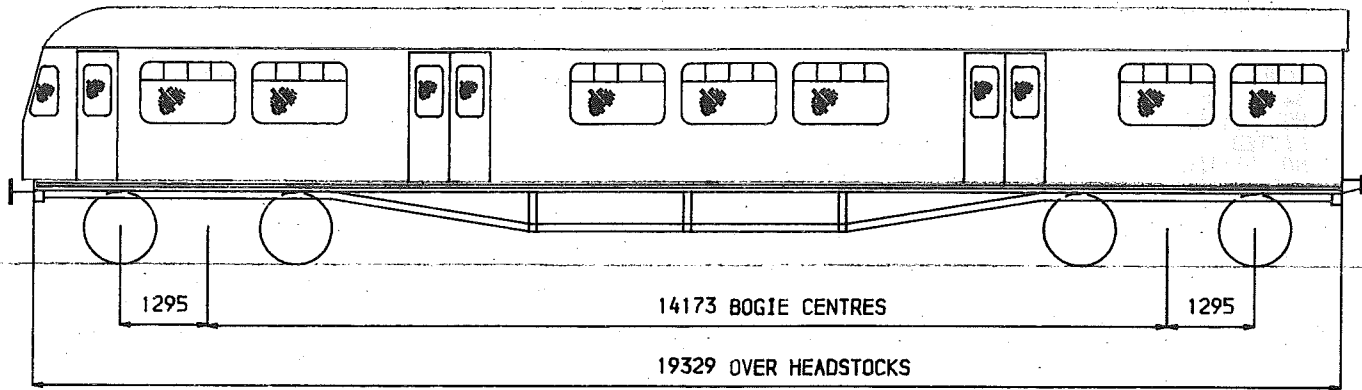

SEATS	83
TOILETS	-
COMPARTMENTS	-
GUARDS COMPARTMENTS	-
VENTILATION	-
CATERING EQUIPMENT	-

ORIGINAL DIAGRAMS FOR REFERENCE.-
BR 375

ISSUE	DATE
2	MAY '81

EE 214

BRAKES
BOGIE/SUSPENSION
BODY CONSTRUCTION
COUPLINGS

TRAIN HEATING
MAX. SPEED M.P.H.
MIN. RAD. CURVE CHAINS
LIGHTING
TARE WEIGHT TONNES
GANGWAYS
A.V.S.
TRAIN COMMUNICATION
BUFFERS

BASIC TYPE

ELECTRO PNEUMATIC
GRESLEY ET11
STEEL
AUTOMATIC DROPHEAD (BUCKEYE) OUTER END-AUTOMATIC SOLID SHANK
(ALLIANCE NO.2) INNER END
ELECTRIC (BR)
75
3.5
TUNGSTEN
34.5
NOT FITTED
FITTED
NOT FITTED
RETRACTABLE SPINDLE-559 X 356 OVAL OUTER END ONLY

ALTERNATIVES

TRACTION DATA FOR MULTIPLE UNITS

EMU- GLASGOW AREA. INTRODUCED 1967.
VOLTAGE 25 & 6.25 KV A.C.OVERHEAD

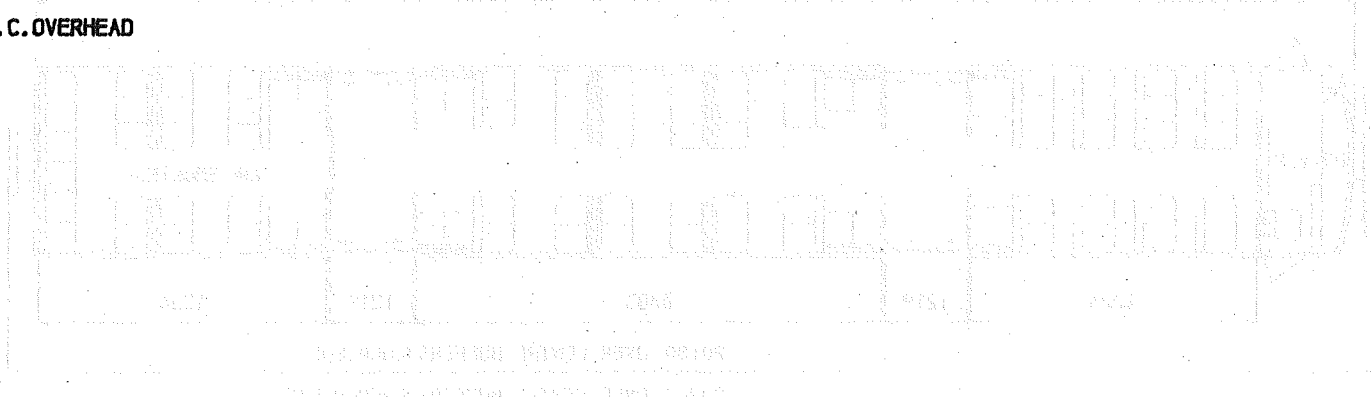

BASIC TYPE

EE 214 0A

VARIANTS

NONE

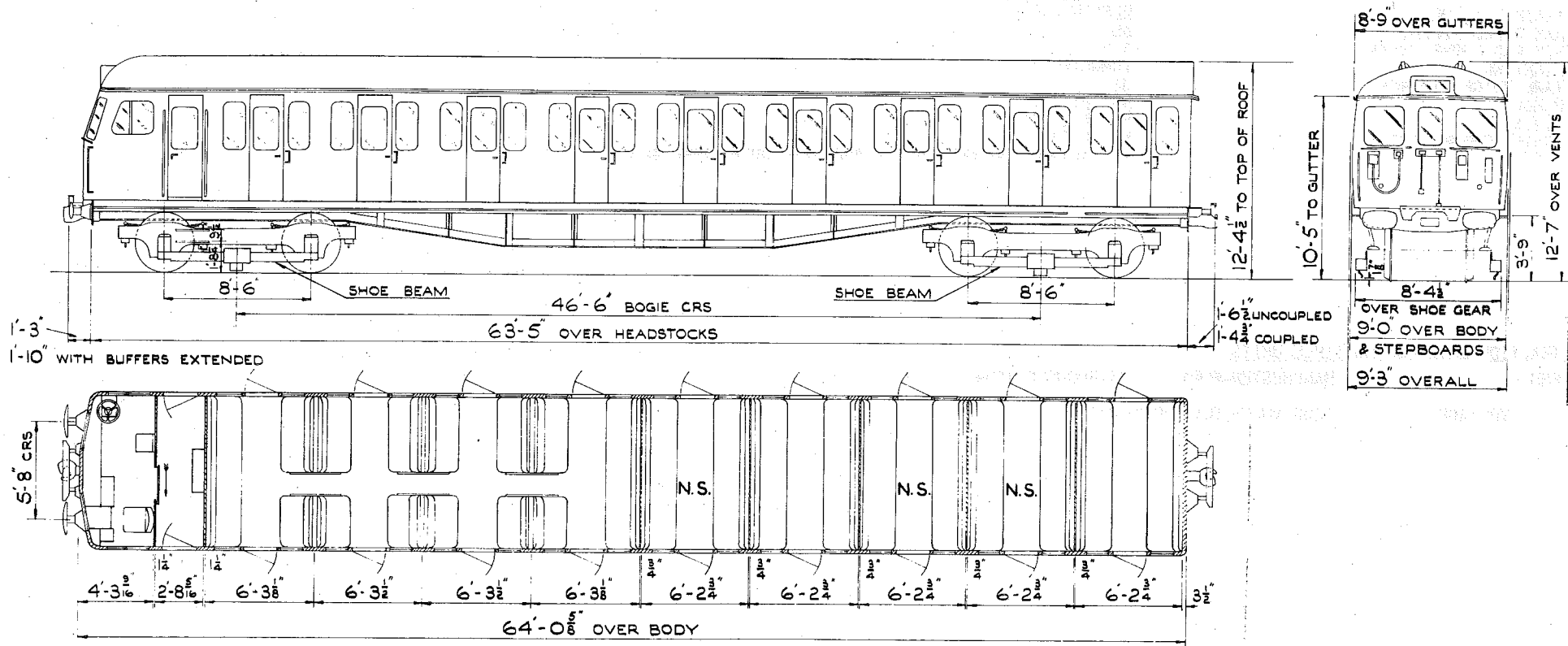

N.S. NON SMOKING.

- SEATS 94
- TOILETS -
- COMPARTMENTS 5 PLUS 1 SALOON
- GUARDS COMPARTMENTS -
- VENTILATION -
- CATERING EQUIPMENT -

ORIGINAL DIAGRAMS FOR REFERENCE.-
BR 443

ISSUE 2 DATE MAY '81

EE 215

BASIC TYPE

ALTERNATIVES

BRAKES
BOGIE/SUSPENSION
BODY CONSTRUCTION
COUPLINGS

ELECTRO PNEUMATIC
CLASS 504 TRAILER
STEEL
AUTOMATIC DROPHEAD (BUCKEYE) OUTER END-AUTOMATIC SOLID SHANK
(ALLIANCE NO.2) INNER END
ELECTRIC (BR)
65
3.5
TUNGSTEN
33
NOT FITTED
NOT FITTED
NOT FITTED
RETRACTABLE SPINDLE-559 X 356 OVAL OUTER END ONLY

TRAIN HEATING
MAX. SPEED M.P.H.
MIN. RAD. CURVE CHAINS
LIGHTING
TARE WEIGHT TONNES
GANGWAYS
A.V.S.
TRAIN COMMUNICATION
BUFFERS

TRACTION DATA FOR MULTIPLE UNITS

EMU- MANCHESTER-BURY. INTRODUCED 1954.
VOLTAGE 1200 VOLTS D.C. THIRD RAIL

BASIC TYPE

EE 215 1A

VARIANTS

NONE

DRIVING TRAILER SECOND

CLASS 317/1

DTS(A)

EE 216

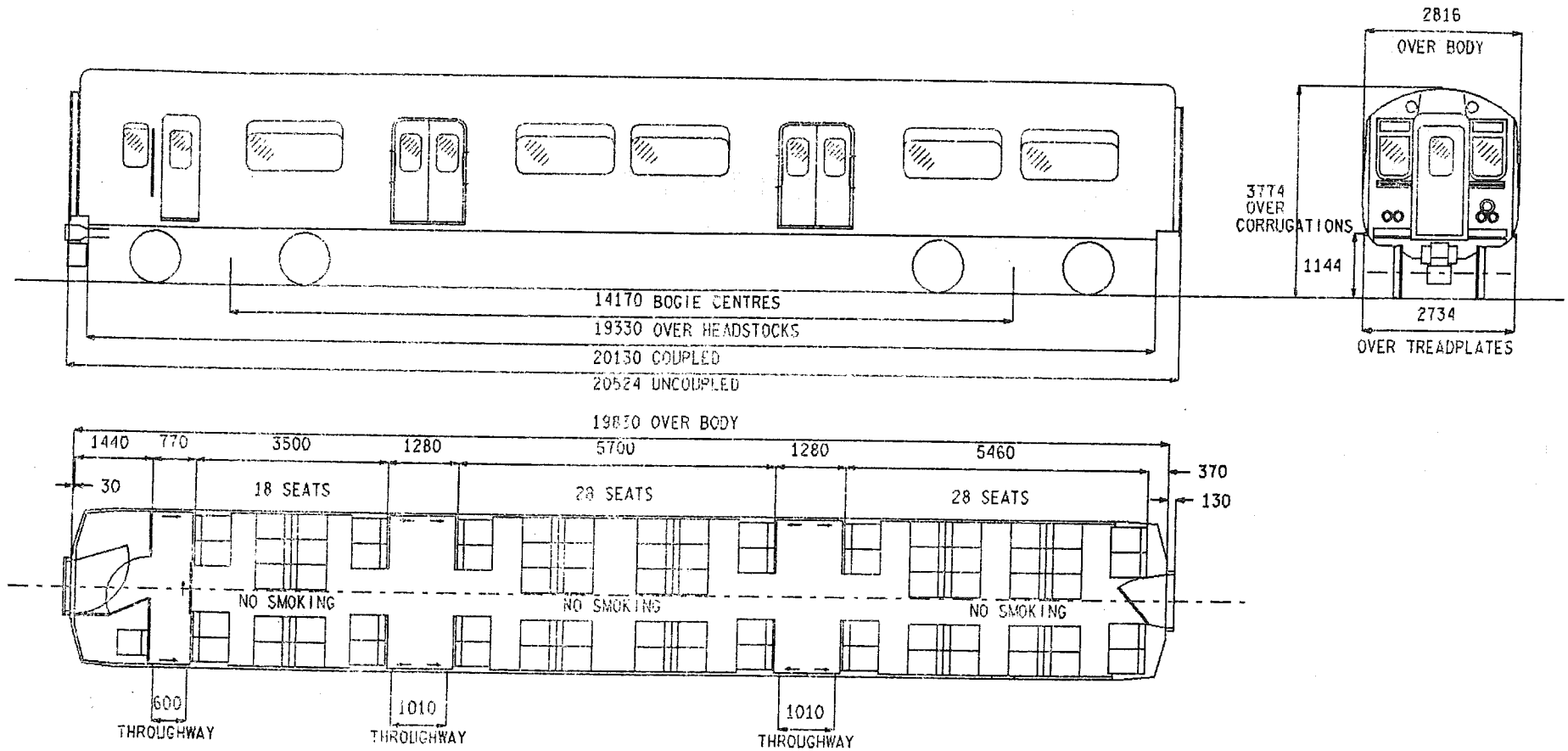

SEATS	74
TOILETS	-
COMPARTMENTS	-
GUARDS COMPARTMENTS	CAB WHEN TRAILING
VENTILATION	PRESSURE
CATERING EQUIPMENT	-

ORIGINAL DIAGRAMS FOR REFERENCE:-
BR 463

ISSUE 4 DATE NOV 88

EE 216

BASIC TYPE

ALTERNATIVES

BRAKES
BOGIE/SUSPENSION
BODY CONSTRUCTION
COUPLINGS
TRAIN HEATING
MAX.SPEED M.P.H.
MIN.RAD.CURVE CHAINS
LIGHTING
TARE WEIGHT TONNES
GANGWAYS

ELECTRO-PNEUMATIC
BT13a & BT13b(ONE OF EACH)
STEEL
AUTOMATIC TIGHTLOCK OUTER END-BAR INNER END
ELECTRIC(BR)WITH PRESSURE VENTILATION & HEATING
90
3.5
FLUORESCENT & TUNGSTEN
29.5
CENTRALLY SUPPORTED-SWIVELLING-FLEXIBLE DIAPHRAGM-STEEL FACE PLATE
OUTER END-FLEXIBLE DIAPHRAGM/RIGID(GRP)INNER END
FITTED
DRIVER/SIGNAL BOX-DRIVER/GUARD-PUBLIC ADDRESS WITH TRANSMITTER
NOT FITTED

A.W.S.
TRAIN COMMUNICATION
BUFFERS

TRACTION DATA FOR MULTIPLE UNITS

EMU- ST.PANCRAS & MOORGATE TO BEDFORD, TRANSFERRED TO E.R. OR W.C.M.L.
VOLTAGE 25 KV A.C.OVERHEAD

BASIC TYPE

EE 216 CA

VARIANTS

NONE

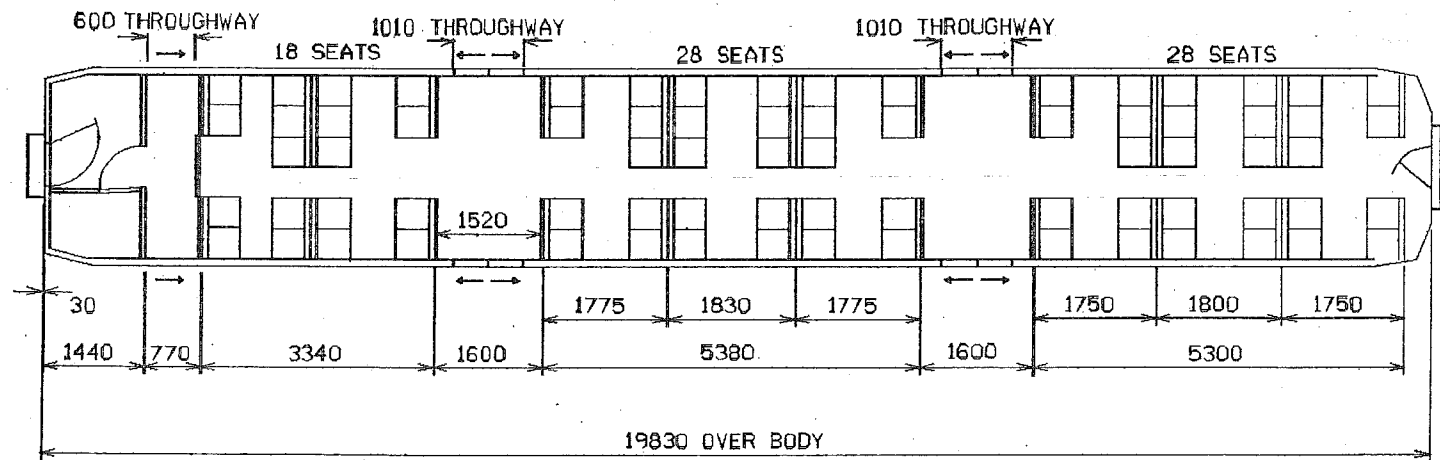
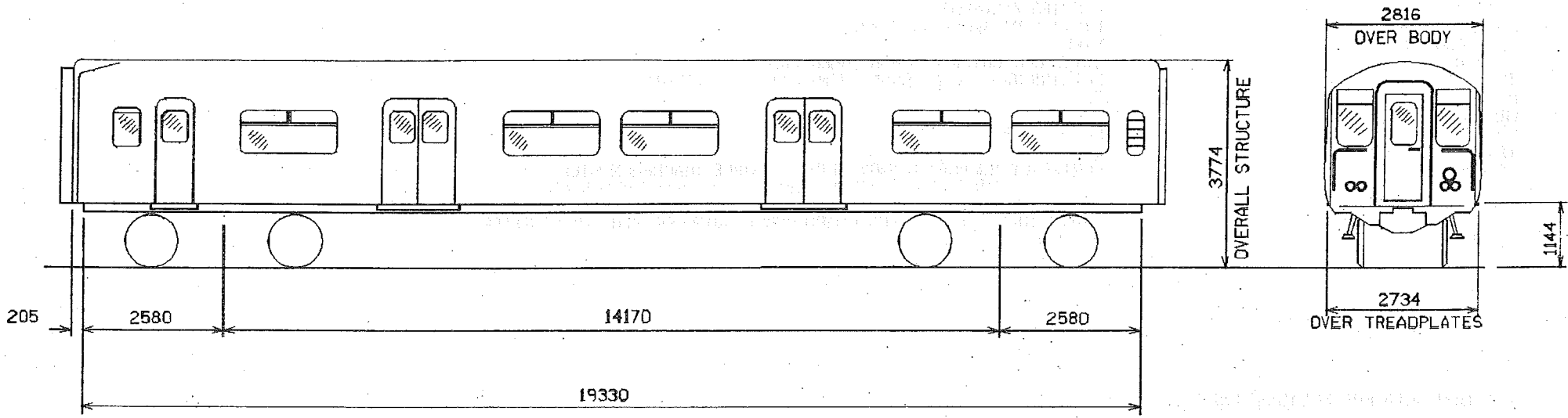

SEATS	74
TOILETS	-
COMPARTMENTS	-
GUARDS COMPARTMENTS	CAB WHEN TRAILING
VENTILATION	-
CATERING EQUIPMENT	-

ISSUE 2 DATE DEC '82

EE 218

BRAKES
BOGIE/SUSPENSION
BODY CONSTRUCTION
COUPLINGS
TRAIN HEATING
MAX SPEED M.P.H.
MIN.RAD.CURVE CHAINS
LIGHTING
TARE WEIGHT TONNES
GANGWAYS

A.W.S.
TRAIN COMMUNICATION
BUFFERS

BASIC TYPE

ELECTRO-PNEUMATIC
BT13_d & BT13_e(ONE OF EACH)
STEEL
TIGHTLOCK OUTER END-BAR INNER END
ELECTRIC(BR)WITH PRESSURE VENTILATION & HEATING
75
3.5
FLUORESCENT
29.5
CENTRALLY SUPPORTED-SWIVELLING-FLEXIBLE DIAPHRAGM-STEEL FACE
PLATE OUTER END-FLEXIBLE DIAPHRAGM/RIGID(GRP)INNER END
FITTED
DRIVER/SIGNAL BOX-DRIVER/GUARD-PUBLIC ADDRESS WITH TRANSMITTER
NOT FITTED

ALTERNATIVES

TRACTION DATA FOR MULTIPLE UNITS

EMU- SOUTHERH REGION ROUTES. INTRODUCED 1982
VOLTAGE 750 VOLTS D.C. THIRD RAIL

BASIC TYPE

EE 218 OA

VARIANTS

NONE

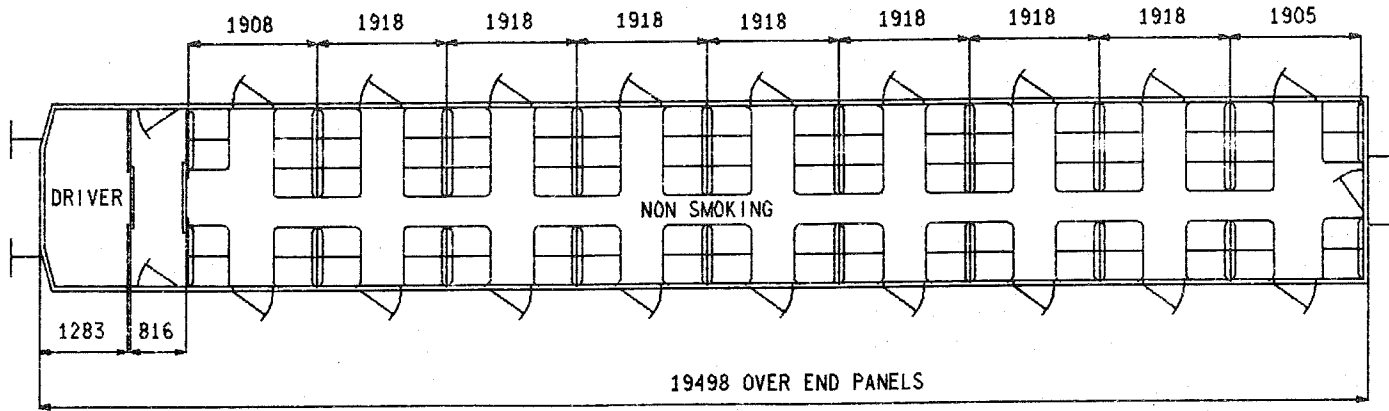
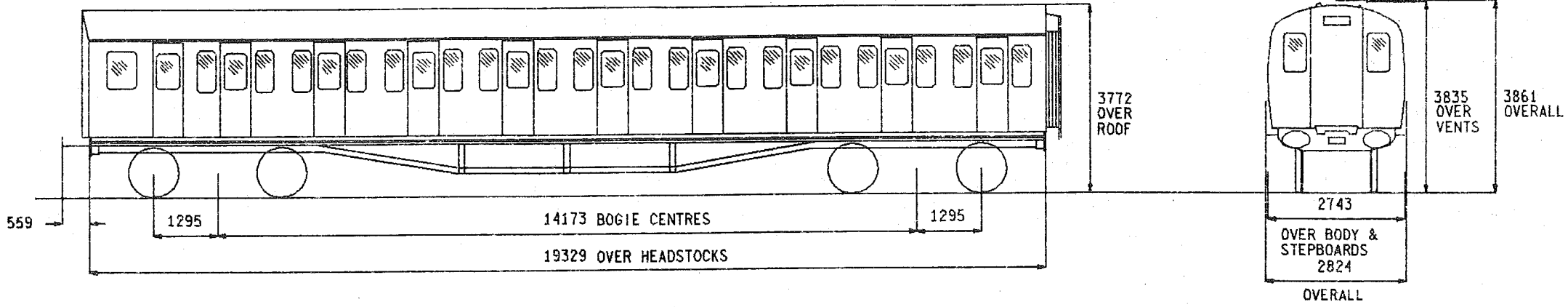

SEATS	88
TOILETS	-
COMPARTMENTS	-
GUARDS COMPARTMENTS	-
VENTILATION	-
CATERING EQUIPMENT	-

ISSUE 3 DATE MAR 87

EE 219

BRAKES
BOGIE/SUSPENSION
BODY CONSTRUCTION
COUPLINGS

TRAIN HEATING
MAX. SPEED M.P.H.
MIN. RAD. CURVE CHAINS
LIGHTING
TARE WEIGHT TONNES
GANGWAYS
A.W.S.
TRAIN COMMUNICATION
BUFFERS

BASIC TYPE

ELECTRO PNEUMATIC
GRESLEY ET2
STEEL
AUTOMATIC DROPHEAD (BUCKEYE) OUTER END-AUTOMATIC SOLID SHANK
(ALLIANCE NO 2) INNER END
ELECTRIC (BR)
75
3.5
FLUORESCENT
32.5 (EST)
PULLMAN WITH RIGID (GRP) INNER PANELS INNER END ONLY
FITTED
DRIVER/GUARD-PUBLIC ADDRESS
RETRACTABLE SPINDLE-559 x 356 OVAL OUTER END-CENTRE INNER END

ALTERNATIVES

B4, B5

TRACTION DATA FOR MULTIPLE UNITS

EMU - GREAT EASTERN OUTER SUBURBAN. INTRODUCED 1958, REFURBISHED 1983.
VOLTAGE 25 & 6.25 KV A.C. OVERHEAD

BASIC TYPE

EE 219 0A-REFURBISHED

VARIANTS

0B B4 BOGIES.
0C B5 BOGIES.

DRIVING TRAILER SECOND

CLASS 305/2
308/1

DTS

EE 220

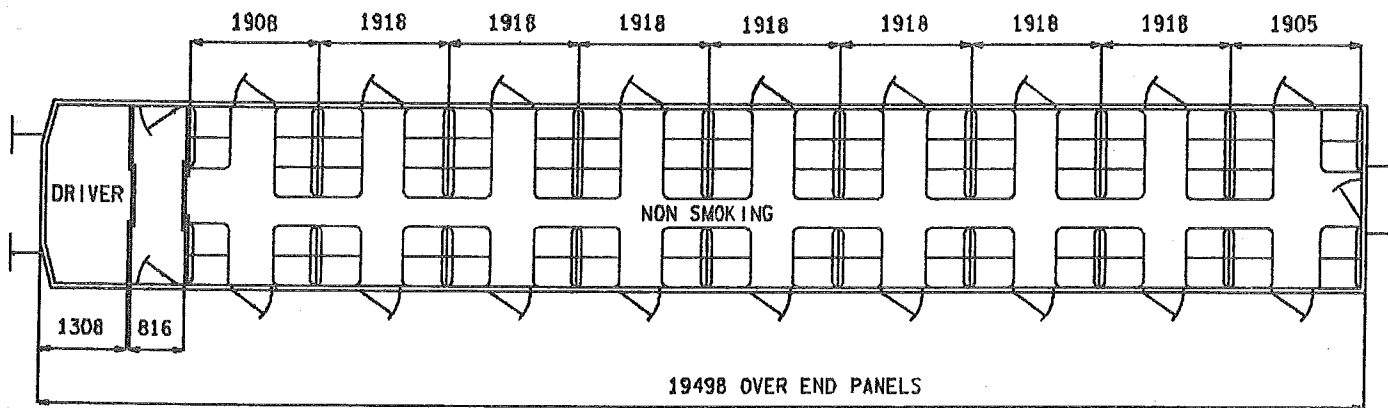
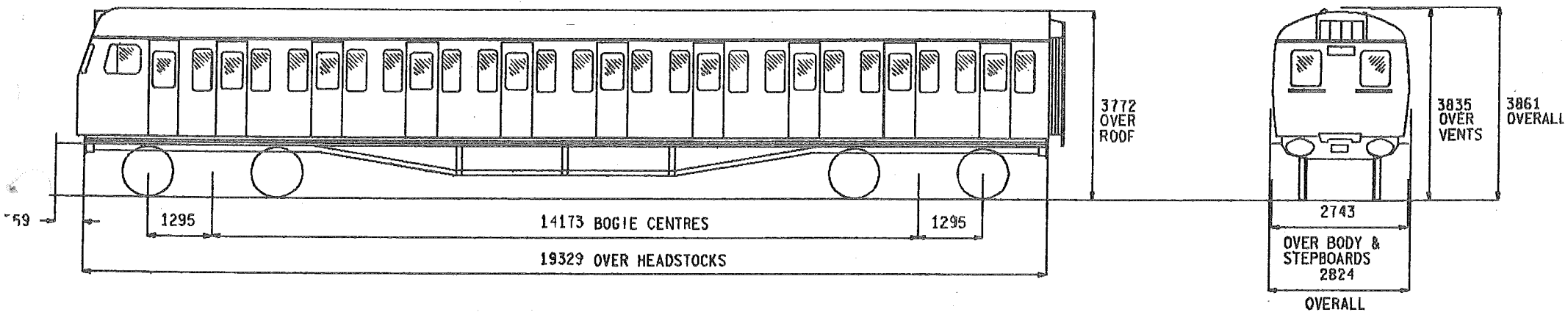

SEATS	88
TOILETS	-
COMPARTMENTS	-
GUARDS COMPARTMENTS	-
VENTILATION	-
CATERING EQUIPMENT	-

ISSUE 1 DATE APR '83

EE 220

BRAKES
BOGIE/SUSPENSION
BODY CONSTRUCTION
COUPLINGS

TRAIN HEATING
MAX. SPEED M.P.H.
MIN. RAD. CURVE CHAINS
LIGHTING
TARE WEIGHT TONNES
GANGWAYS
A.W.S.
TRAIN COMMUNICATION
BUFFERS

BASIC TYPE

ELECTRO PNEUMATIC
GRESLEY ET5
STEEL
AUTOMATIC DROPHEAD(BUCKEYE) OUTER END-AUTOMATIC SOLID SHANK
(ALLIANCE NO 2) INNER END
ELECTRIC(BR)
3.5
FLUORESCENT
33(EST)
PULLMAN WITH RIGID(GRP) INNER PANELS INNER END ONLY
FITTED
DRIVER/GUARD-PUBLIC ADDRESS
RETRACTABLE SPINDLE-559 X 356 OVAL OUTER END-CENTRE INNER END

ALTERNATIVES

GRESLEY ET8

TRACTION DATA FOR MULTIPLE UNITS

EMU- GREAT EASTERN OUTER SUBURBAN. INTRODUCED CLASS 305/2 1960, CLASS 308/1 1961. REFURBISHED 1983.
VOLTAGE 25 & 6.25 KV A.C. OVERHEAD

BASIC TYPE

EE 220 0A-REFURBISHED

VARIANTS

0B CLASS 308/1 GRESLEY ET8 BOGIES.

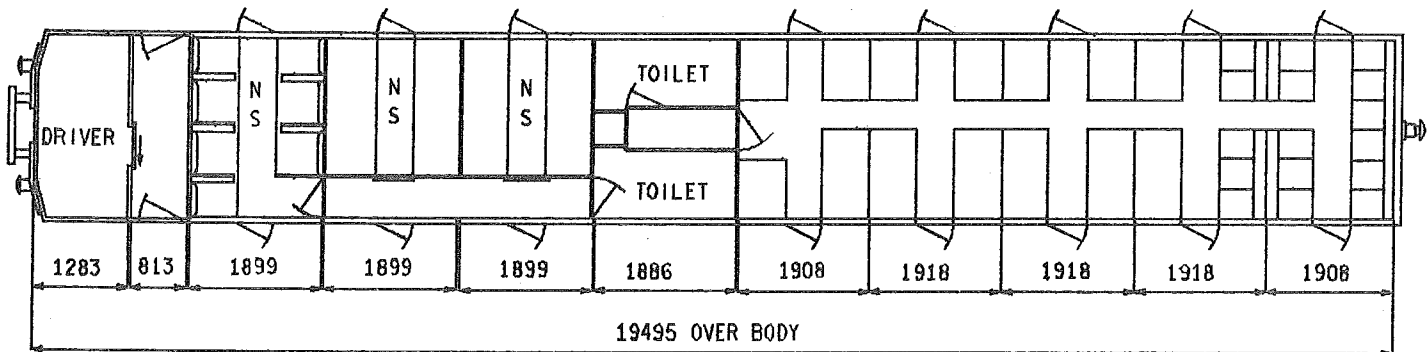
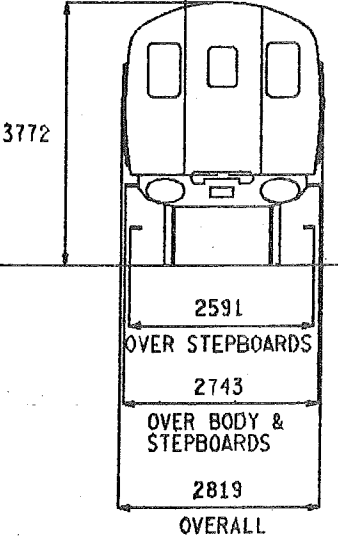
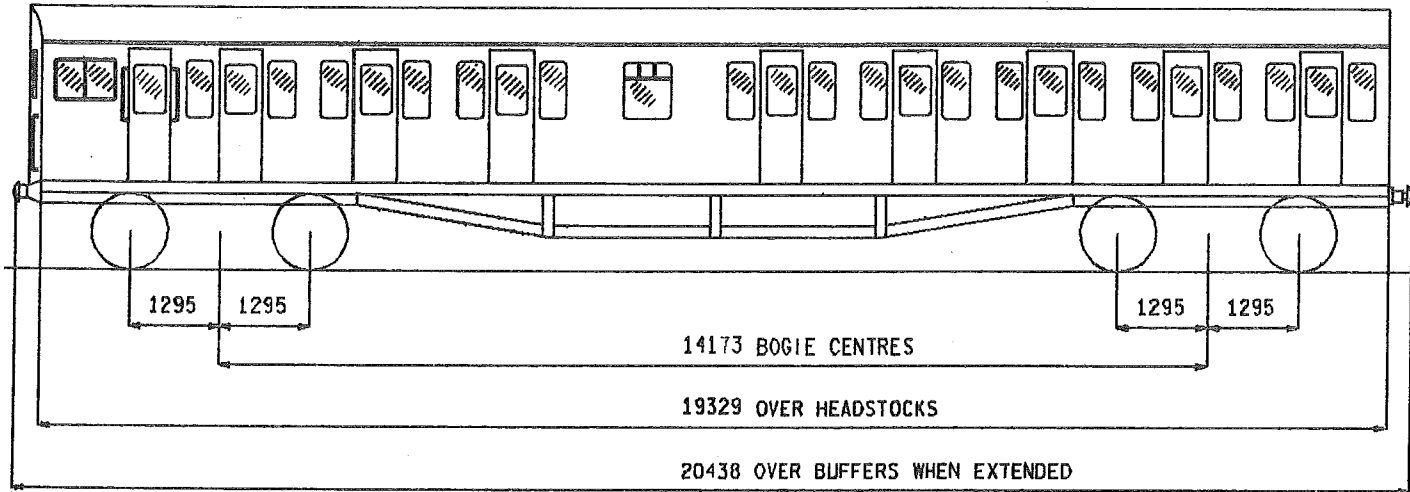

N.S. - NON SMOKING

- SEATS 69 SECOND CLASS
- TOILETS 2
- COMPARTMENTS 3 PLUS 1 SALOON
- GUARDS COMPARTMENTS -
- VENTILATION -
- CATERING EQUIPMENT -

ISSUE 1 DATE APR '83

EE 221

BRAKES
BOGIE/SUSPENSION
BODY CONSTRUCTION
COUPLINGS
TRAIN HEATING
MAX.SPEED M.P.H.
MIN.RAD.CURVE CHAINS
LIGHTING
TARE WEIGHT TONNES
GANGWAYS
A.W.S.
TRAIN COMMUNICATION
BUFFERS
S.R.DESIGN REFERENCE CODE

BASIC TYPE

ELECTRO PNEUMATIC
S.R.MK 4 UNPOWERED
STEEL
AUTOMATIC DROPHEAD(BUCKEYE) OUTER END-3 LINK INNER END
ELECTRIC(BR)
90
3.5
TUNGSTEN
32.5
NOT FITTED
NOT FITTED
DRIVER/GUARD
RETRACTABLE SPINDLE-559 X 356 OVAL OUTER END-CENTRE INNER END
DX

ALTERNATIVES

FITTED

TRACTION DATA FOR MULTIPLE UNITS

EMU- INTRODUCED AS CLASS 414/2 1957, RECLASSIFIED 1983.
VOLTAGE 750/850 VOLTS D.C. THIRD RAIL

BASIC TYPE

EE 221 0A

VARIANTS

1A A.W.S.FITTED.

DRIVING TRAILER SECOND

CLASS 413/3

DTS

EE 222

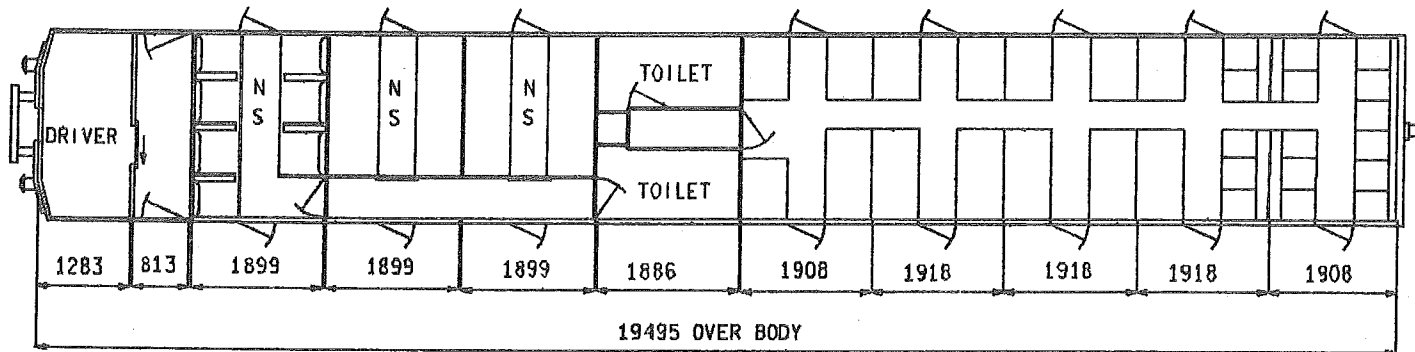
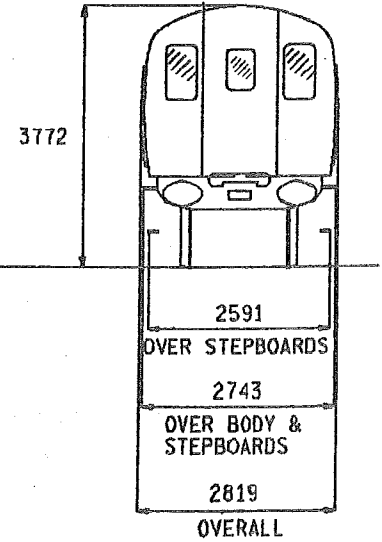
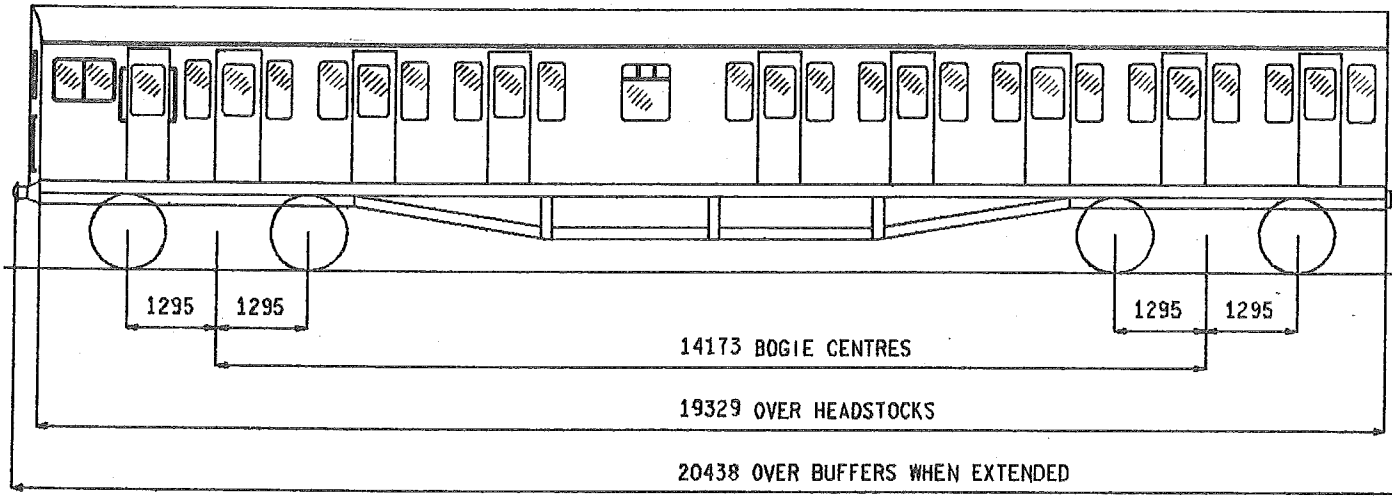

N.S. - NON SMOKING

SEATS	69 SECOND CLASS
TOILETS	2
COMPARTMENTS	3 PLUS 1 SALOON
GUARDS COMPARTMENTS	-
VENTILATION	-
CATERING EQUIPMENT	-

ISSUE DATE
1 APR '83

EE 222

BRAKES
Bogie/Suspension
BODY CONSTRUCTION
COUPLINGS
TRAIN HEATING
MAX. SPEED M.P.H.
MIN. RAD. CURVE CHAINS
LIGHTING
TARE WEIGHT TONNES
GANGWAYS
A.W.S.
TRAIN COMMUNICATION
BUFFERS
S.R. DESIGN REFERENCE CODE

BASIC TYPE

ELECTRO PNEUMATIC
S.R. MK 4 UNPOWERED
STEEL
AUTOMATIC DROPHEAD (BUCKEYE) OUTER END-3 LINK INNER END
ELECTRIC (BR)
90
3.5
TUNGSTEN
32.5
NOT FITTED
NOT FITTED
DRIVER/GUARD
RETRACTABLE SPINDLE-559 X 356 OVAL OUTER END-CENTRE INNER END
DZ

ALTERNATIVES

FITTED

TRACTION DATA FOR MULTIPLE UNITS

EMU- INTRODUCED AS CLASS 414/3 1957, RECLASSED 1983.
VOLTAGE 750/850 VOLTS D.C. THIRD RAIL

BASIC TYPE

EE 222 0A

VARIANTS

1A A.W.S. FITTED.

DRIVING TRAILER SECOND

CLASS 302

DTS

EE 223

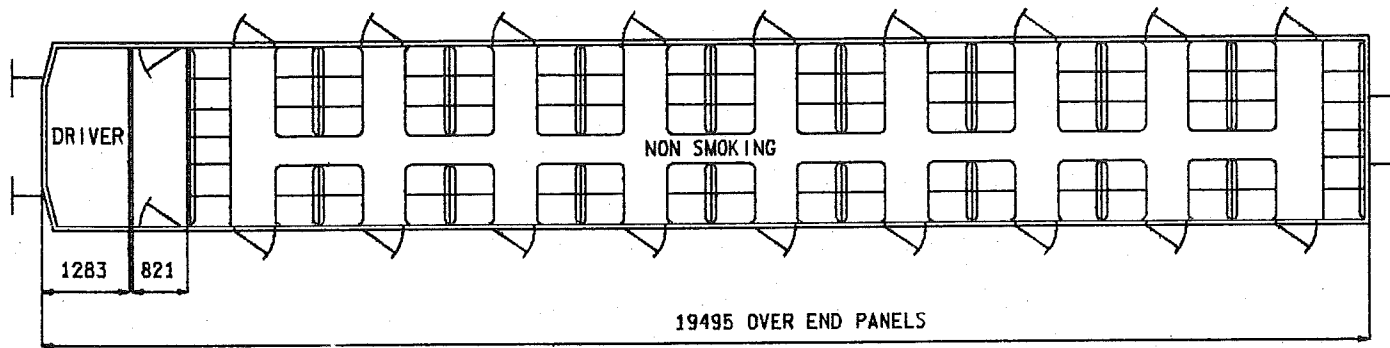
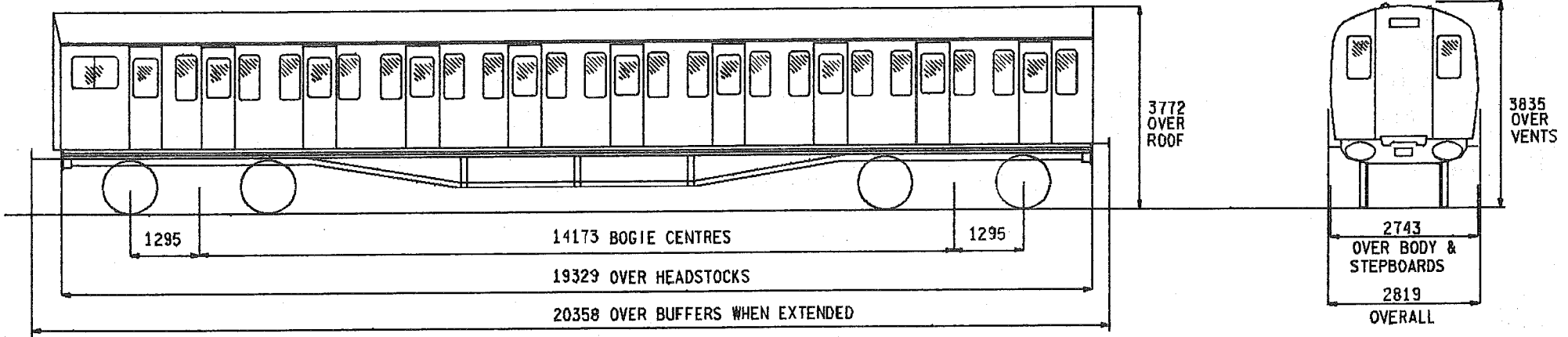

- SEATS 92
- TOILETS -
- COMPARTMENTS -
- GUARDS COMPARTMENTS -
- VENTILATION -
- CATERING EQUIPMENT -

ISSUE 1 DATE AUG '83

EE 223

BRAKES
BOGIE/SUSPENSION
BODY CONSTRUCTION
COUPLINGS

TRAIN HEATING
MAX. SPEED M.P.H.
MIN. RAD. CURVE CHAINS
LIGHTING
TARE WEIGHT TONNES
GANGWAYS
A.W.S.
TRAIN COMMUNICATION
BUFFERS

BASIC TYPE

ELECTRO PNEUMATIC
GRESLEY ET2
STEEL
AUTOMATIC DROPHEAD (BUCKEYE) OUTER END-AUTOMATIC SOLID SHANK
(ALLIANCE NO 2) INNER END
ELECTRIC (BR)
75
3.5
TUNGSTEN
32.5
NOT FITTED
FITTED
NOT FITTED
RETRACTABLE SPINDLE-559 x 356 OVAL OUTER END-CENTRE INNER END

ALTERNATIVES

TRACTION DATA FOR MULTIPLE UNITS

EMJ - FENCHURCH ST.- SHOEBURYNNESS. INTRODUCED 1958.
VOLTAGE 25 & 6.25 KV A.C. OVERHEAD

BASIC TYPE

EE 223 0A-TEMPORARILY REFURBISHED

VARIANTS

NONE

DRIVING TRAILER SECOND

CLASS 317/2

DTS(A)

EE 224

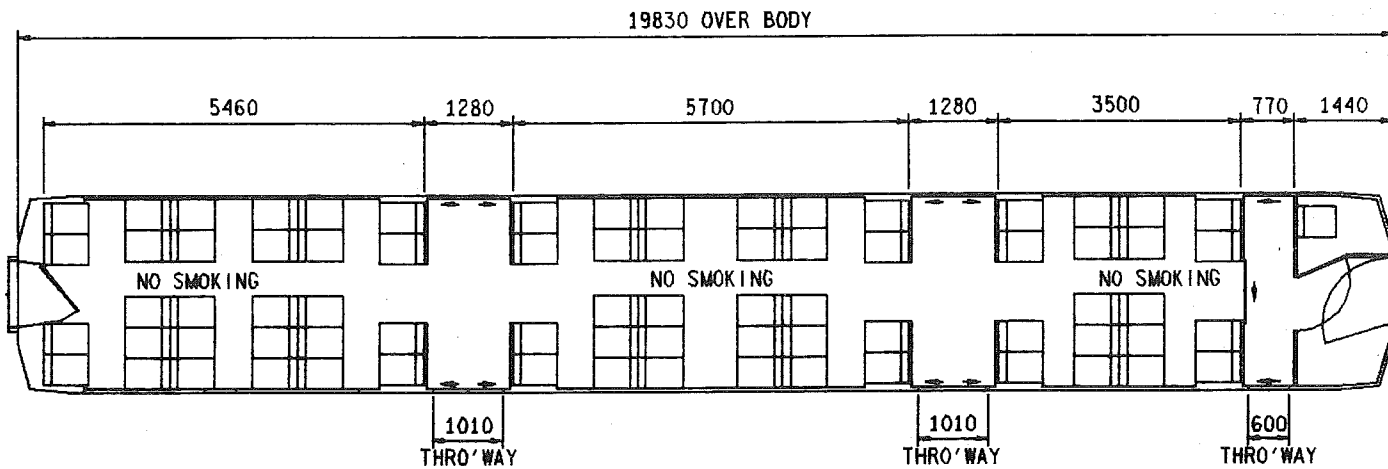
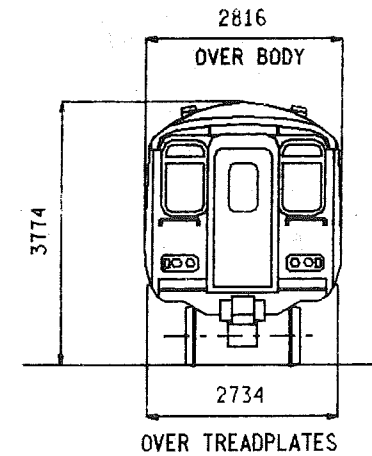
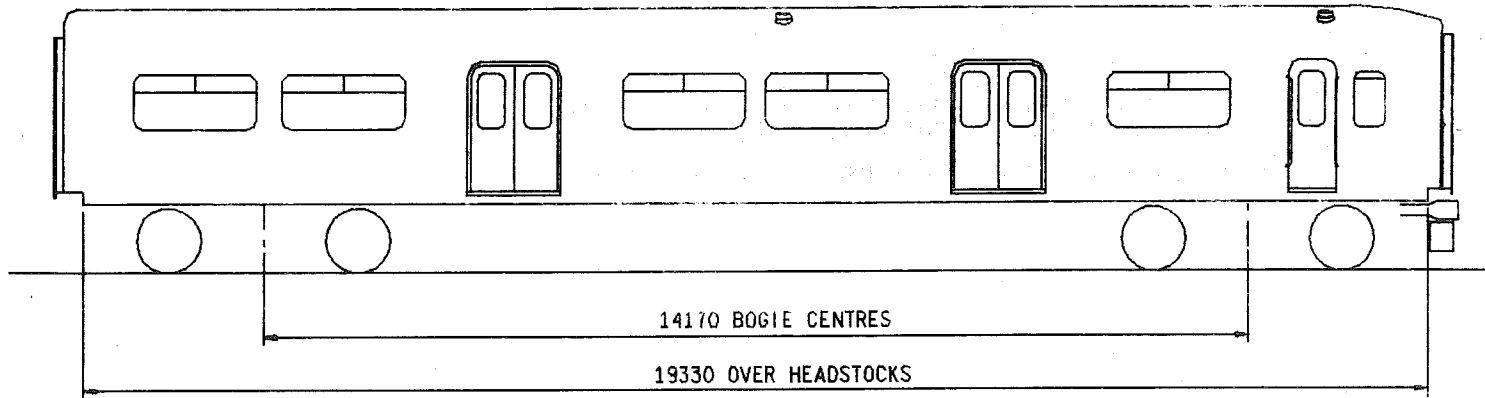

SEATS	74
TOILETS	-
COMPARTMENTS	-
GUARDS COMPARTMENTS	-
VENTILATION	-
CATERING EQUIPMENT	-

ISSUE DATE
1 MAY 85

EE 224

BRAKES
BOGIE/SUSPENSION
BODY CONSTRUCTION
COUPLINGS
TRAIN HEATING
MAX.SPEED M.P.H.
MIN.RAD.CURVE CHAINS
LIGHTING
TARE WEIGHT TONNES
GANGWAYS

A.W.S.
TRAIN COMMUNICATION
BUFFERS

BASIC TYPE

ELECTRO-PNEUMATIC
BT13a & BT13b(ONE OF EACH)
STEEL
AUTOMATIC TIGHTLOCK OUTER END-BAR INNER END
ELECTRIC(BR)
90
3.5
FLUORESCENT & TUNGSTEN
29.5
CENTRALLY SUPPORTED-SWIVELLING-FLEXIBLE DIAPHRAGM-STEEL FACE PLATE
OUTER END-FLEXIBLE DIAPHRAGM/RIGID(GRP)INNER END
FITTED
DRIVER/SIGNAL BOX-DRIVER/GUARD-PUBLIC ADDRESS WITH TRANSMITTER
NOT FITTED

ALTERNATIVES

TRACTION DATA FOR MULTIPLE UNITS

EMU- GREAT NORTHERN OUTER SUBURBAN
VOLTAGE 25 KV A.C.OVERHEAD

BASIC TYPE

EE 224 0A

VARIANTS

NONE

DRIVING TRAILER SECOND

CLASS 317/2

DTS(B)

EE 225

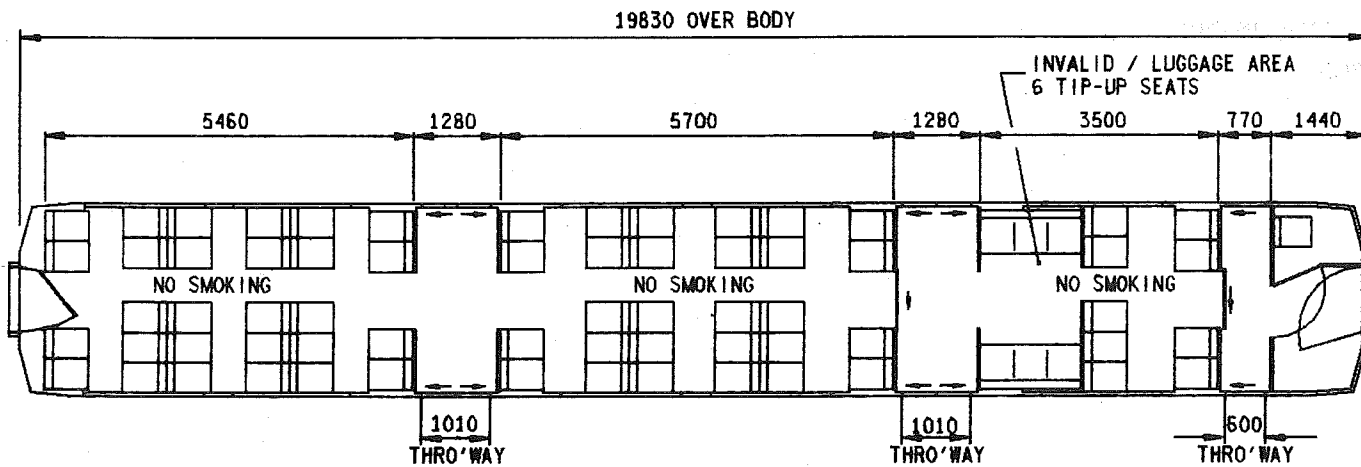
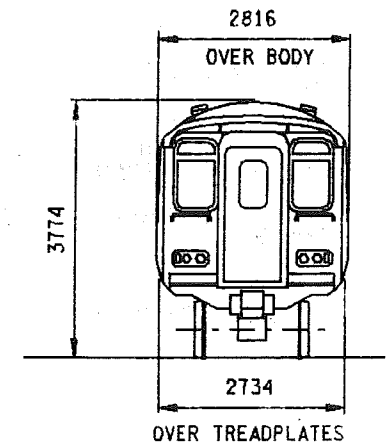
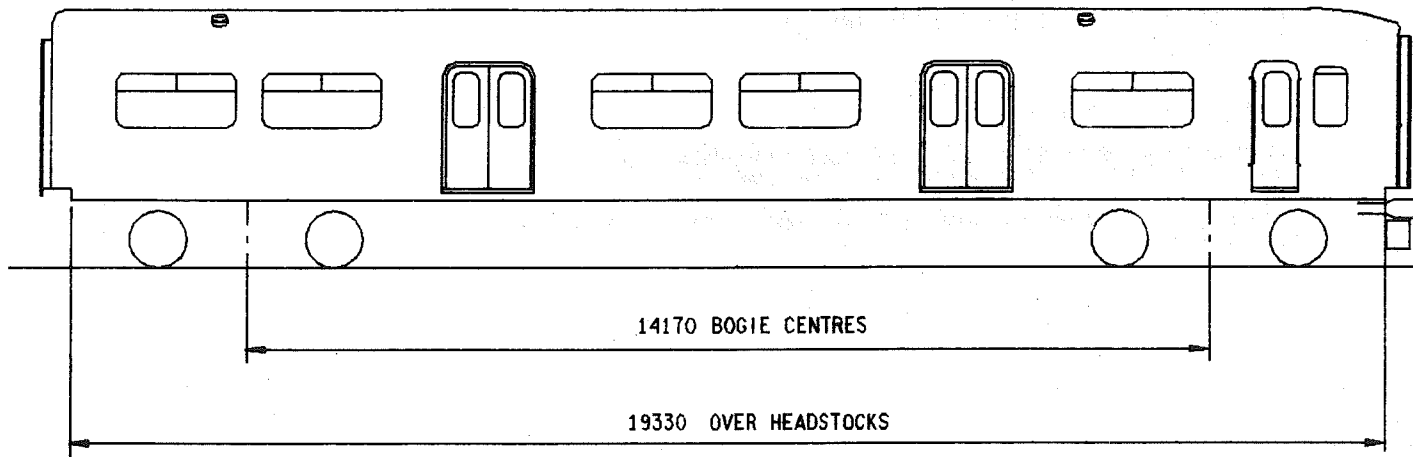

SEATS	71
TOILETS	-
COMPARTMENTS	-
GUARDS COMPARTMENTS	-
VENTILATION	-
CATERING EQUIPMENT	-

ISSUE DATE
1 MAY 85

EE 225

BRAKES
BOGIE/SUSPENSION
BODY CONSTRUCTION
COUPLINGS
TRAIN HEATING
MAX.SPEED M.P.H.
MIN.RAD.CURVE CHAINS
LIGHTING
TARE WEIGHT TONNES
GANGWAYS

A.W.S.
TRAIN COMMUNICATION
BUFFERS

BASIC TYPE

ELECTRO-PNEUMATIC
BT13a & BT13b(ONE OF EACH)
STEEL
AUTOMATIC TIGHTLOCK OUTER END-BAR INNER END
ELECTRIC(BR)
90
3.5
FLUORESCENT & TUNGSTEN
29.5
CENTRALLY SUPPORTED-SWIVELLING-FLEXIBLE DIAPHRAGM-STEEL FACE PLATE
OUTER END-FLEXIBLE DIAPHRAGM/RIGID(GRP)INNER END
FITTED
DRIVER/SIGNAL BOX-DRIVER/GUARD-PUBLIC ADDRESS WITH TRANSMITTER
NOT FITTED

ALTERNATIVES

TRACTION DATA FOR MULTIPLE UNITS

EMU- GREAT NORTHERN OUTER SUBURBAN
VOLTAGE 25 KV A.C.OVERHEAD

BASIC TYPE

EE 225 0A

VARIANTS

NONE

DRIVING TRAILER SECOND

CLASS 455/4

DTS

EE 226

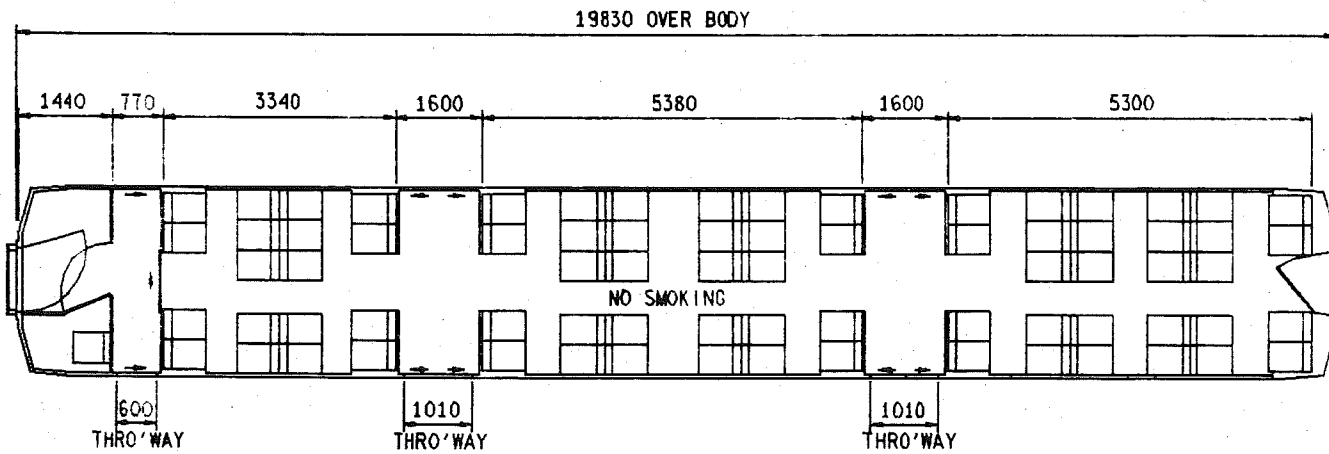
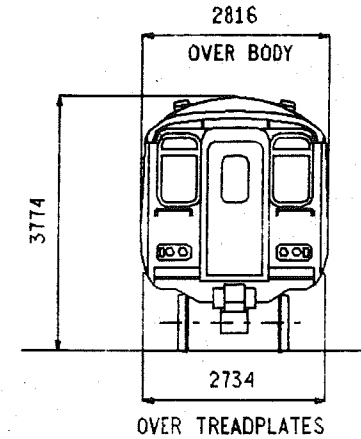
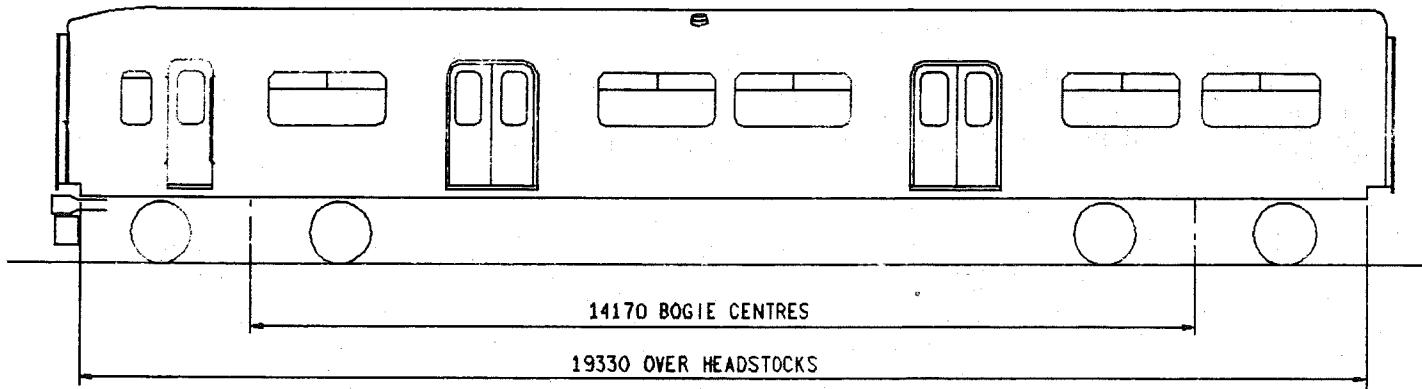

- | | |
|---------------------|-------------------|
| SEATS | 74 |
| TOILETS | - |
| COMPARTMENTS | - |
| GUARDS COMPARTMENTS | CAB WHEN TRAILING |
| VENTILATION | - |
| CATERING EQUIPMENT | - |

ISSUE 1 DATE AUG 85

EE 226

BRAKES
BOGIE/SUSPENSION
BODY CONSTRUCTION
COUPLINGS
TRAIN HEATING
MAX.SPEED M.P.H.
MIN.RAD.CURVE CHAINS
LIGHTING
TARE WEIGHT TONNES
GANGWAYS

A.W.S.
TRAIN COMMUNICATION
BUFFERS

BASIC TYPE

ELECTRO-PNEUMATIC
BT13d & BT13e(ONE OF EACH)
STEEL
TIGHTLOCK OUTER END-BAR INNER END
ELECTRIC(BR)
75
3.5
FLUORESCENT
29.5
CENTRALLY SUPPORTED-SWIVELLING-FLEXIBLE DIAPHRAGM-STEEL FACE PLATE
OUTER END-FLEXIBLE DIAPHRAGM/RIGID(GRP)INNER END
FITTED
DRIVER/SIGNAL BOX-DRIVER/GUARD-PUBLIC ADDRESS WITH TRANSMITTER
NOT FITTED

ALTERNATIVES

TRACTION DATA FOR MULTIPLE UNITS

EMU- SOUTHERN REGION ROUTES. INTRODUCED 1985
VOLTAGE 750 VOLTS D.C. THIRD RAIL

BASIC TYPE

EE 226 0A

VARIANTS

NONE

DRIVING TRAILER SECOND

CLASS 318

DTS(A)

EE 227

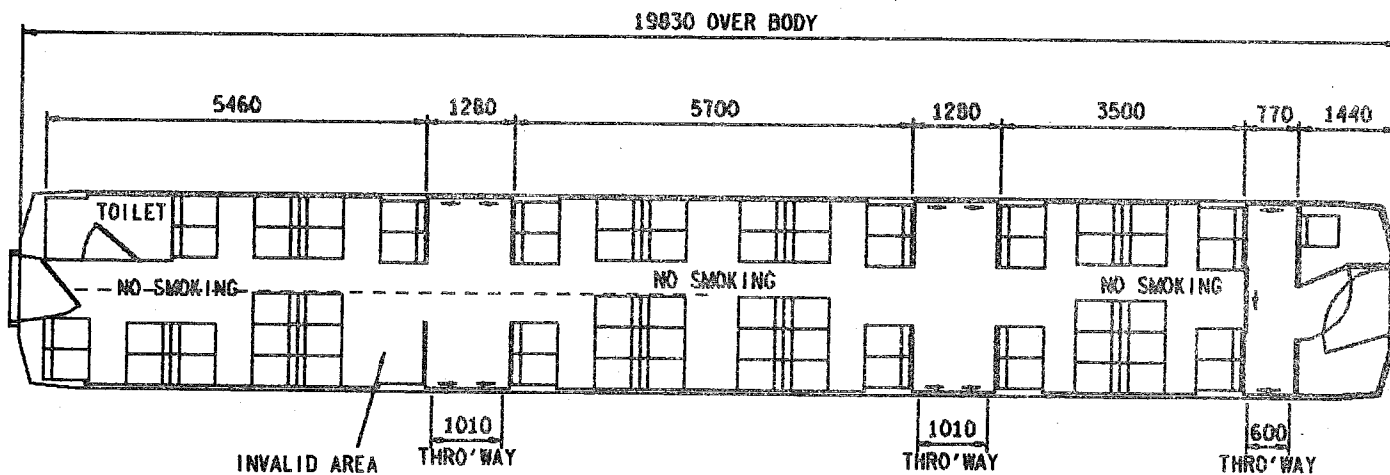
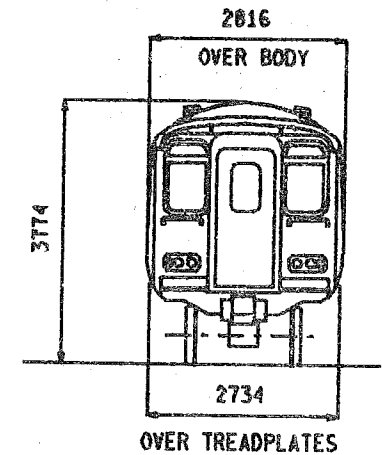
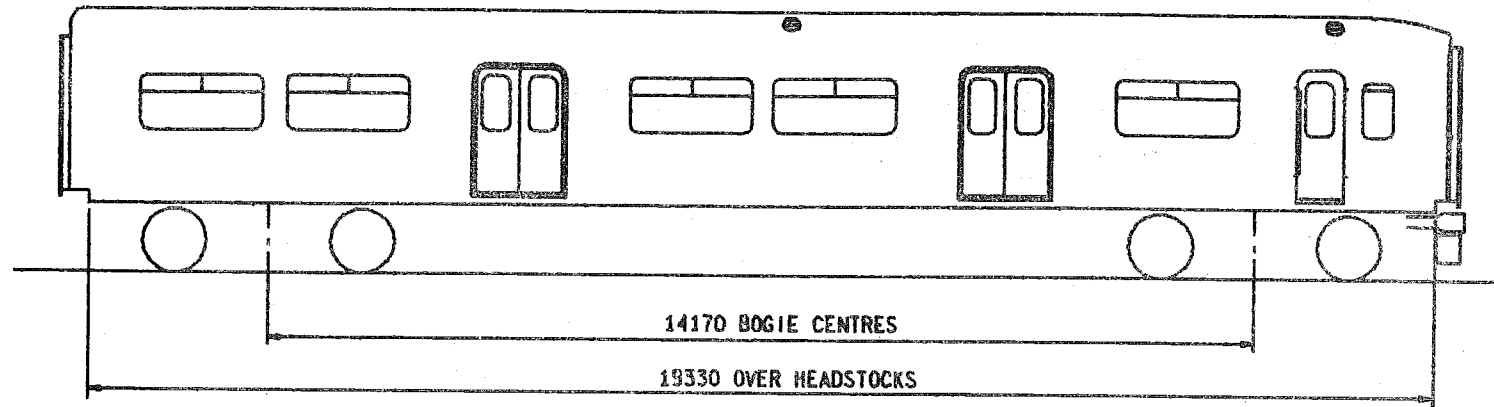

SEATS	66
TOILETS	1
COMPARTMENTS	-
GUARDS COMPARTMENTS	-
VENTILATION	-
CATERING EQUIPMENT	-

ISSUE 1 DATE OCT 86

(visit <http://www.barrowmoremrg.co.uk>)

EE 227

BRAKES
BOGIE/SUSPENSION
BODY CONSTRUCTION
COUPLINGS
TRAIN HEATING
MAX.SPEED M.P.H.
MIN.RAD.CURVE CHAINS
LIGHTING
TARE WEIGHT TONNES
GANGWAYS

A.W.S.
TRAIN COMMUNICATION
BUFFERS

BASIC TYPE

ELECTRO-PNEUMATIC
BT13a & BT13b(ONE OF EACH)
STEEL
AUTOMATIC TIGHTLOCK OUTER END-BAR INNER END
ELECTRIC(BR)
90
3.5
FLUORESCENT & TUNGSTEN
30.1
CENTRALLY SUPPORTED-SWIVELLING-FLEXIBLE DIAPHRAGM-STEEL FACE PLATE
OUTER END-FLEXIBLE DIAPHRAGM/RIGID(GRP)INNER END
FITTED
DRIVER/SIGNAL BOX-DRIVER/GUARD-PUBLIC ADDRESS WITH TRANSMITTER
NOT FITTED

ALTERNATIVES

TRACTION DATA FOR MULTIPLE UNITS

EMU- GLASGOW AREA
VOLTAGE 25 KV A.C.OVERHEAD

BASIC TYPE

EE 227 OA

VARIANTS

NONE

DRIVING TRAILER SECOND

CLASS 318

DTS(B)

EE 228

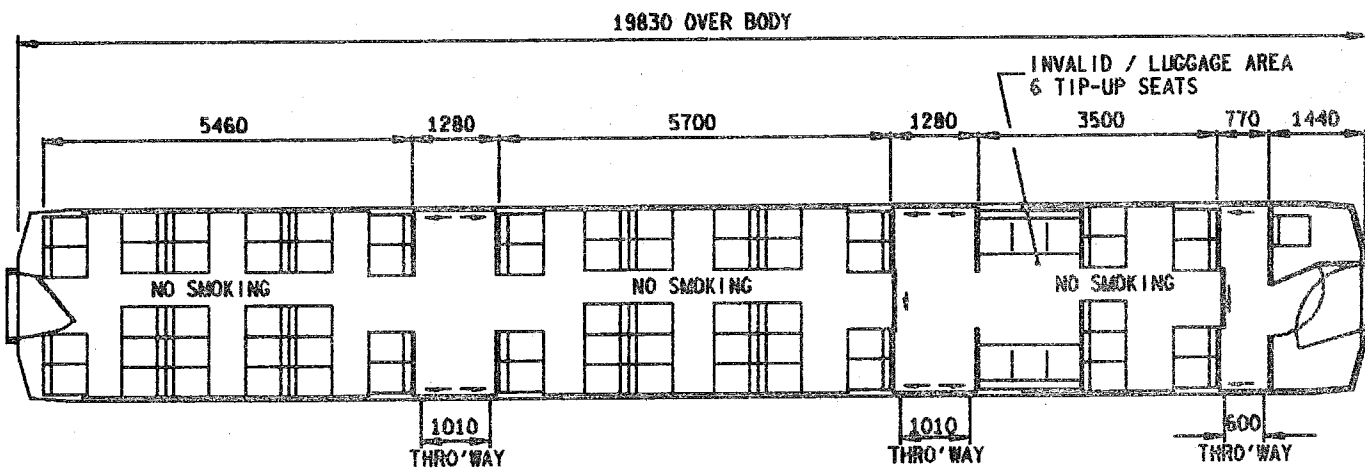
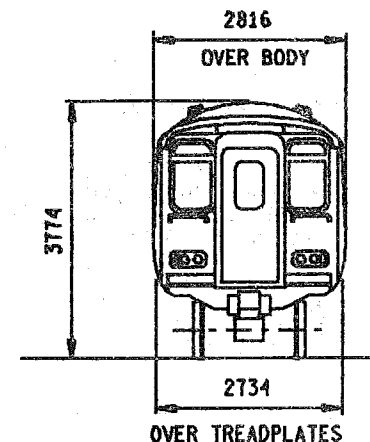
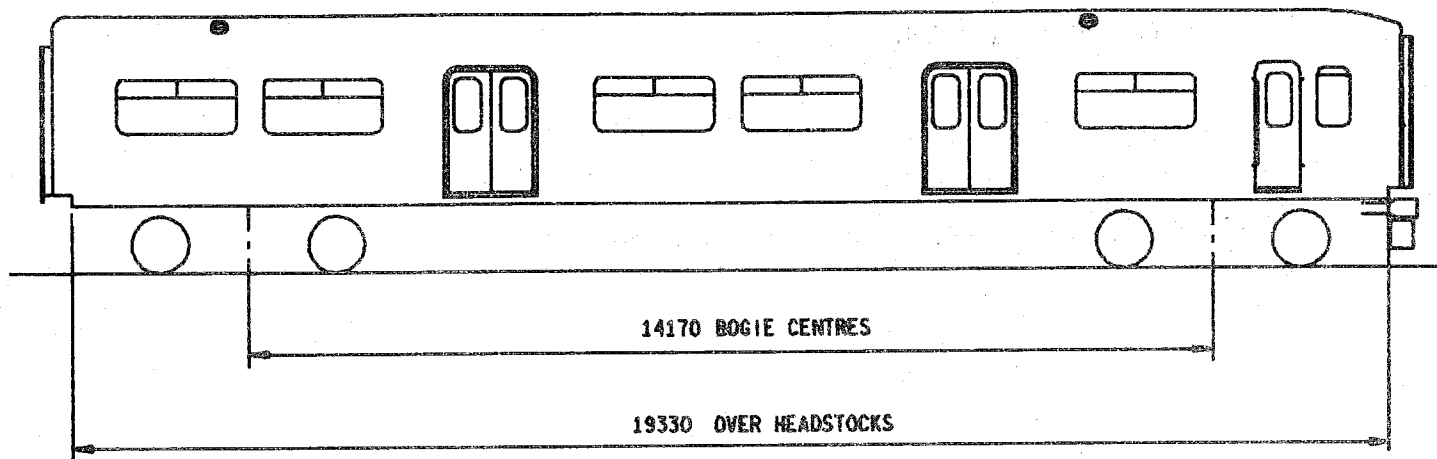

SEATS	71
TOILETS	-
COMPARTMENTS	-
GUARDS COMPARTMENTS	-
VENTILATION	-
CATERING EQUIPMENT	-

ISSUE 1 DATE OCT 86

EE 228

BRAKES
BOGIE/SUSPENSION
BODY CONSTRUCTION
COUPLINGS
TRAIN HEATING
MAX. SPEED M.P.H.
MIN. RAD. CURVE CHAINS
LIGHTING
TARE WEIGHT TONNES
GANGWAYS

A.W.S.
TRAIN COMMUNICATION
BUFFERS

BASIC TYPE

ELECTRO-PNEUMATIC
BT13a & BT13b (ONE OF EACH)
STEEL
AUTOMATIC TIGHTLOCK OUTER END-BAR INNER END
ELECTRIC (BR)
90
3.5
FLUORESCENT & TUNGSTEN
29.6
CENTRALLY SUPPORTED-SWIVELLING-FLEXIBLE DIAPHRAGM-STEEL FACE PLATE
OUTER END-FLEXIBLE DIAPHRAGM/RIGID (GRP) INNER END
FITTED
DRIVER/SIGNAL BOX-DRIVER/GUARD-PUBLIC ADDRESS WITH TRANSMITTER
NOT FITTED

ALTERNATIVES

TRACTION DATA FOR MULTIPLE UNITS

EMU-	GLASGOW AREA
VOLTAGE	25 KV A.C. OVERHEAD

BASIC TYPE

EE 228 0A

VARIANTS

NONE

DRIVING TRAILER SECOND

CLASS 309/2
309/3

DTS

EE 229

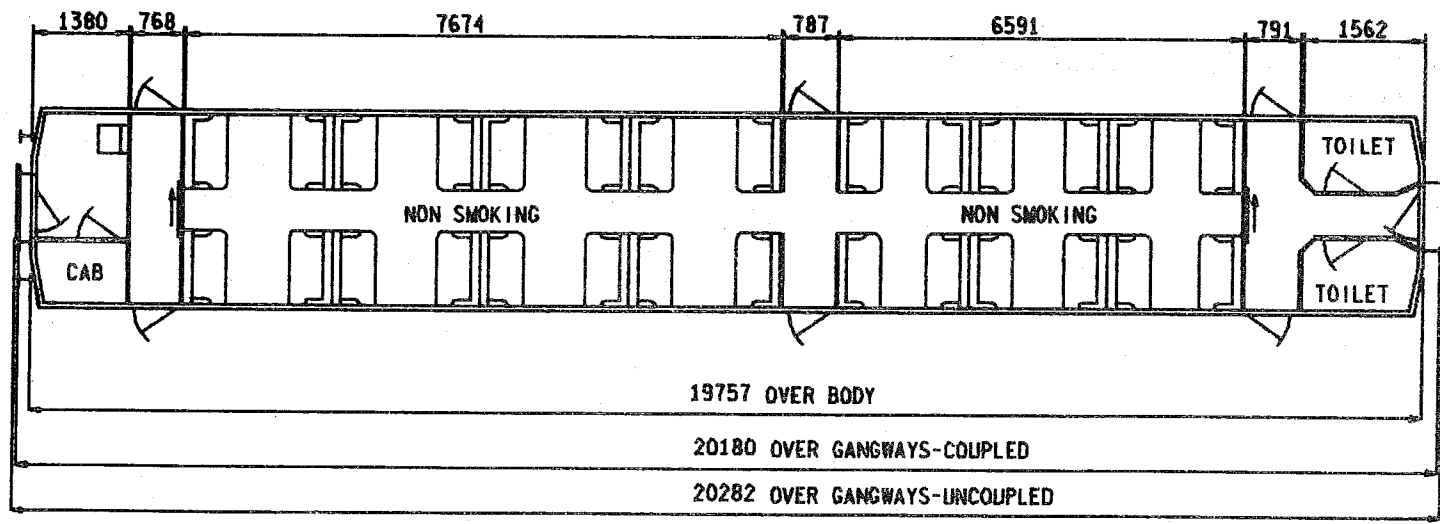
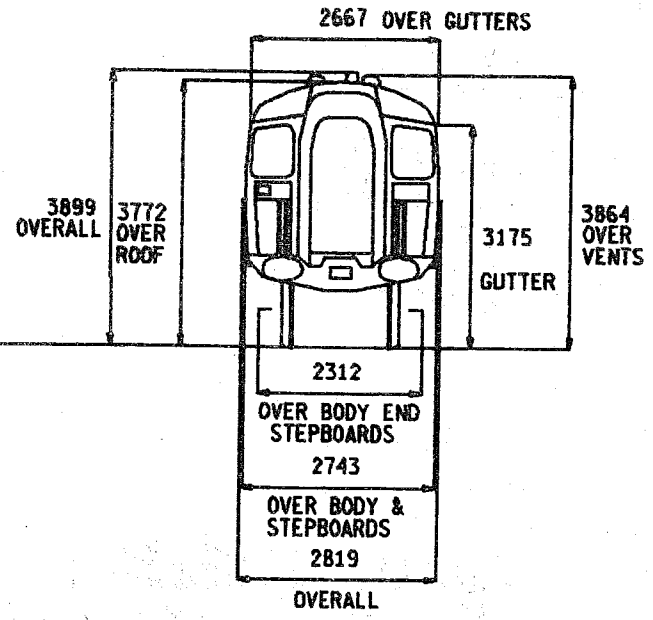
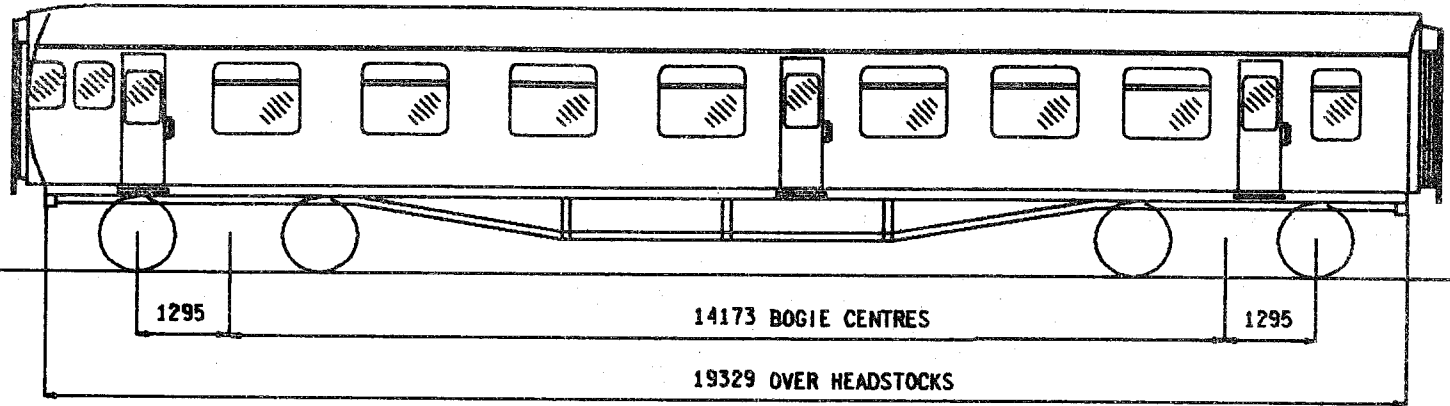

SEATS	56
TOILETS	2
COMPARTMENTS	-
GUARDS COMPARTMENTS	-
VENTILATION	-
CATERING EQUIPMENT	-

ISSUE 1 DATE OCT '86

EE 229

BRAKES
BOGIE/SUSPENSION
BODY CONSTRUCTION
COUPLINGS

TRAIN HEATING
MAX.SPEED M.P.H.
MIN.RAD.CURVE CHAINS
LIGHTING
TARE WEIGHT TONNES
GANGWAYS
TRAIN COMMUNICATION
BUFFERS

BASIC TYPE

ELECTRO PNEUMATIC
COMMONWEALTH
STEEL
AUTOMATIC DROPHEAD(BUCKEYE) OUTER END
AUTOMATIC SOLID SHANK(ALLIANCE NO.2) INNER END
ELECTRIC(BR)
100
3.5
FLUORESCENT & TUNGSTEN
32
PULLMAN
PUBLIC ADDRESS
RETRACTABLE SPINDLE-559x356 OVAL-OUTER END ONLY

ALTERNATIVES

TRACTION DATA FOR MULTIPLE UNITS

EMU- LIVERPOOL ST.-CLACTON & WALTON INTRODUCED 1962, REFUBISHED 1985.
VOLTAGE 25 & 6.25 KV A.C.OVERHEAD.

BASIC TYPE

EE 229 0A

VARIANTS

NONE

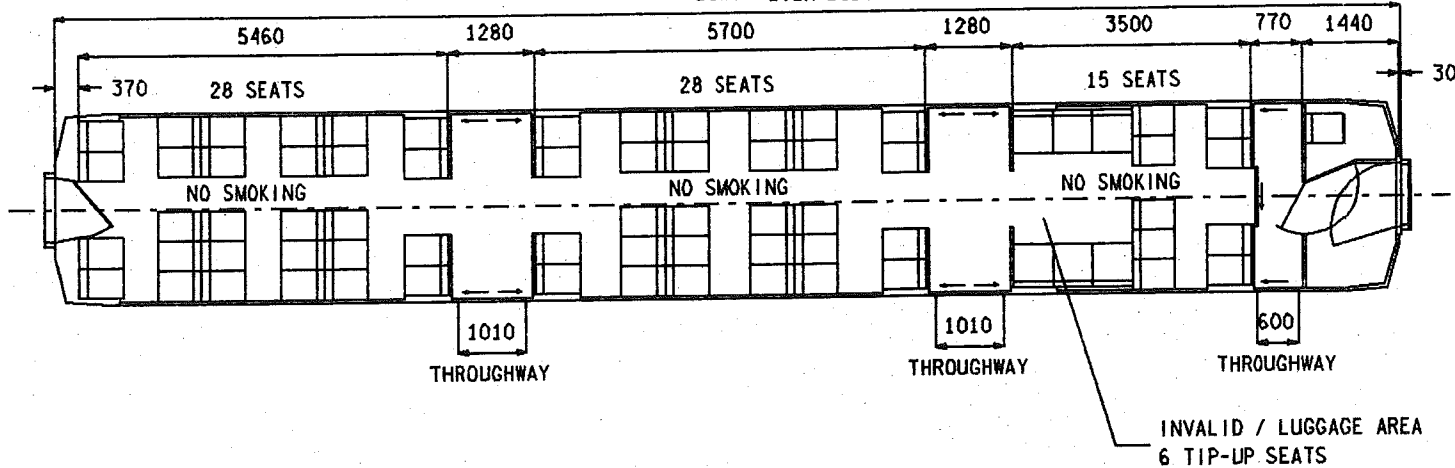
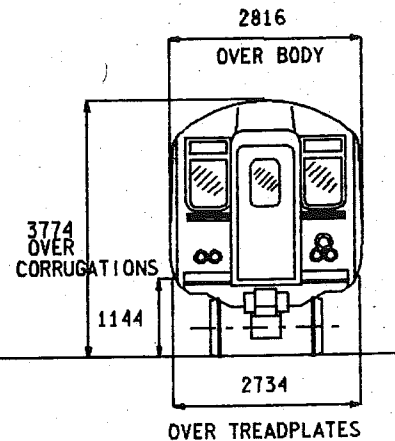
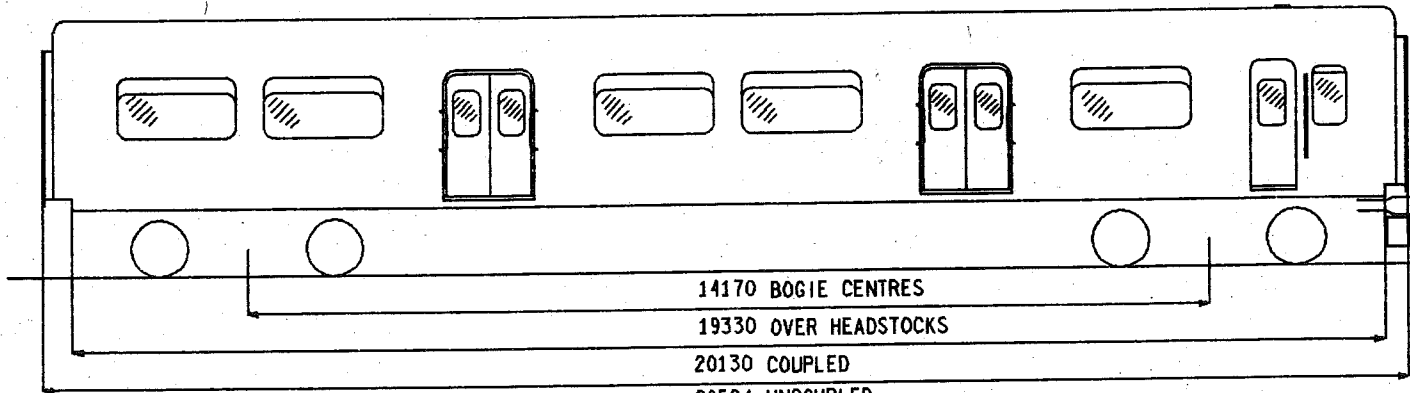

- SEATS 71
- TOILETS -
- COMPARTMENTS -
- GUARDS COMPARTMENTS -
- VENTILATION -
- CATERING EQUIPMENT -
- CAB WHEN TRAILING -
- PRESSURE -

ORIGINAL DIAGRAMS FOR REFERENCE:-
 BR 463

ISSUE 1 DATE JAN 86

EE 232

BRAKES
BOGIE/SUSPENSION
BODY CONSTRUCTION
COUPLINGS
TRAIN HEATING
MAX.SPEED M.P.H.
MIN.RAD.CURVE CHAINS
LIGHTING
TARE WEIGHT TONNES
GANGWAYS

A.W.S.
TRAIN COMMUNICATION
BUFFERS

BASIC TYPE

ELECTRO-PNEUMATIC
BT13a & BT13b(ONE OF EACH)
STEEL
AUTOMATIC TIGHTLOCK OUTER END-BAR INNER END
ELECTRIC(BR)WITH PRESSURE VENTILATION & HEATING
90
3.5
FLUORESCENT & TUNGSTEN
29.5
CENTRALLY SUPPORTED-SWIVELLING-FLEXIBLE DIAPHRAGM-STEEL FACE PLATE
OUTER END-FLEXIBLE DIAPHRAGM/RIGID(GRP)INNER END
FITTED
DRIVER/SIGNAL BOX-DRIVER/GUARD-PUBLIC ADDRESS WITH TRANSMITTER
NOT FITTED

ALTERNATIVES

TRACTION DATA FOR MULTIPLE UNITS

EMU- ST.PANCRAS & MOORGATE TO BEDFORD. TRANSFERED TO GREAT NORTHERN SUBURBAN 1986
VOLTAGE 25 KV A.C.OVERHEAD

BASIC TYPE

EE 232 0A

VARIANTS

NONE

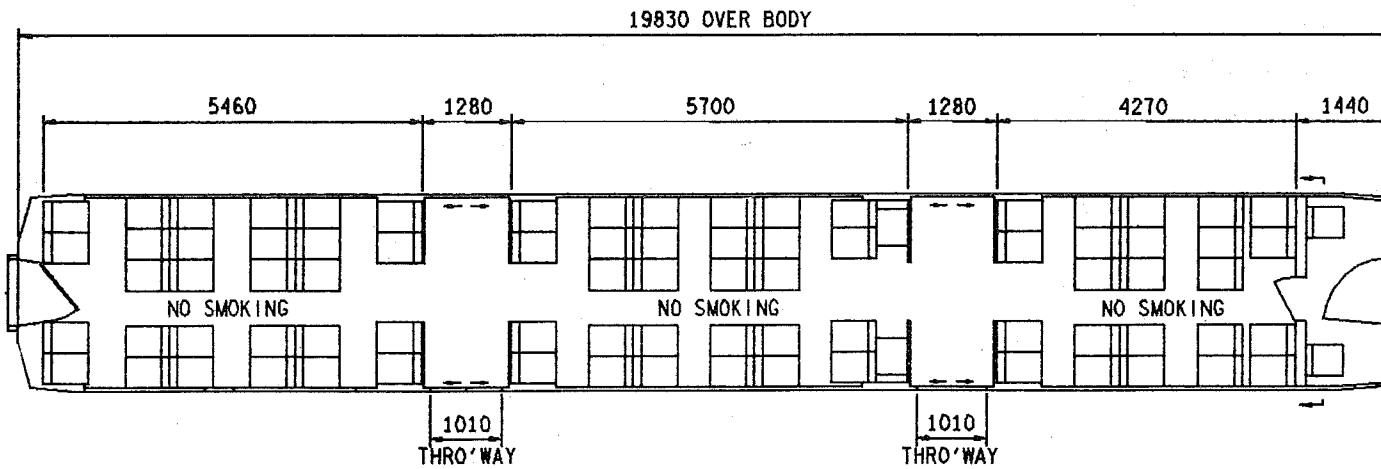
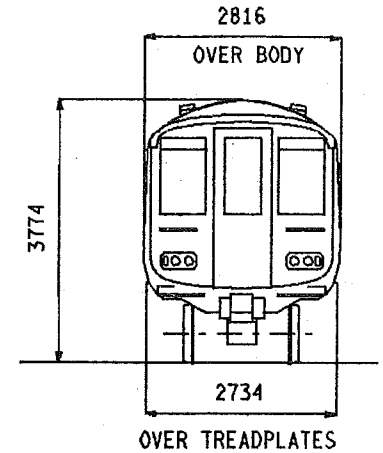
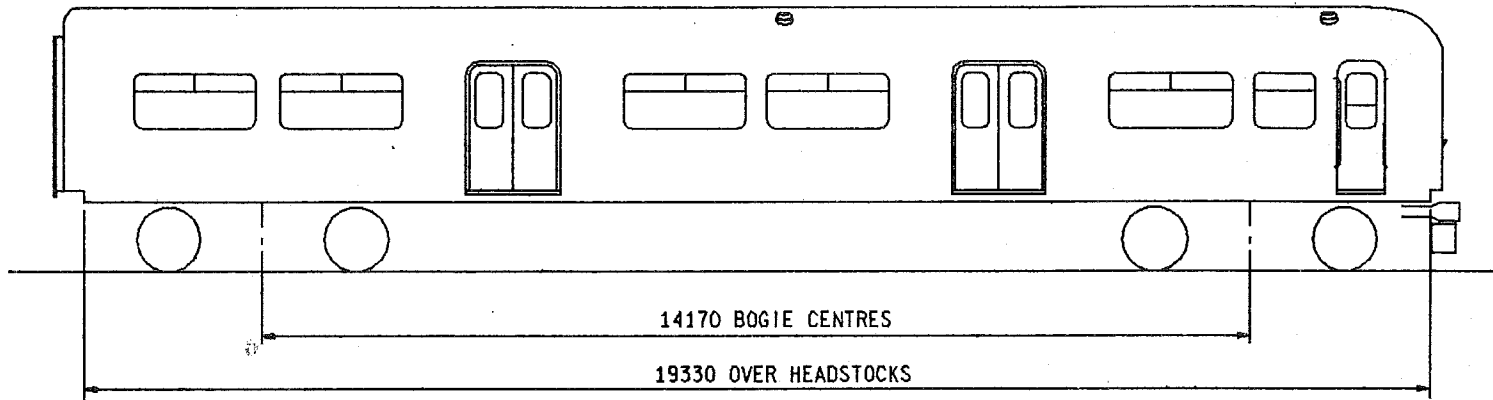

- SEATS 81
- TOILETS -
- COMPARTMENTS -
- GUARDS COMPARTMENTS -
- VENTILATION -
- CATERING EQUIPMENT -

ISSUE 1 DATE JAN 88

EE 233

BRAKES
BOGIE/SUSPENSION
BODY CONSTRUCTION
COUPLINGS
TRAIN HEATING
MAX.SPEED M.P.H.
MIN.RAD.CURVE CHAINS
LIGHTING
TARE WEIGHT TONNES
GANGWAYS
A.W.S.
TRAIN COMMUNICATION
BUFFERS

BASIC TYPE

ELECTRO-PNEUMATIC
T3-7a & T3-7b(ONE OF EACH)
STEEL
AUTOMATIC TIGHTLOCK OUTER END-BAR INNER END
ELECTRIC(BR)
100
3.5
FLUORESCENT
28.2
FLEXIBLE DIAPHRAGM/RIGID(GRP)INNER END
FITTED
DRIVER/SIGNAL BOX-DRIVER/GUARD-PUBLIC ADDRESS WITH TRANSMITTER
NOT FITTED

ALTERNATIVES

TRACTION DATA FOR MULTIPLE UNITS

EMU- CROSS LONDON SERVICES. INTRODUCED 1987
VOLTAGE 25 KV A.C.OVERHEAD & 750V D.C.THIRD RAIL

BASIC TYPE

EE 233 OA

VARIANTS

NONE

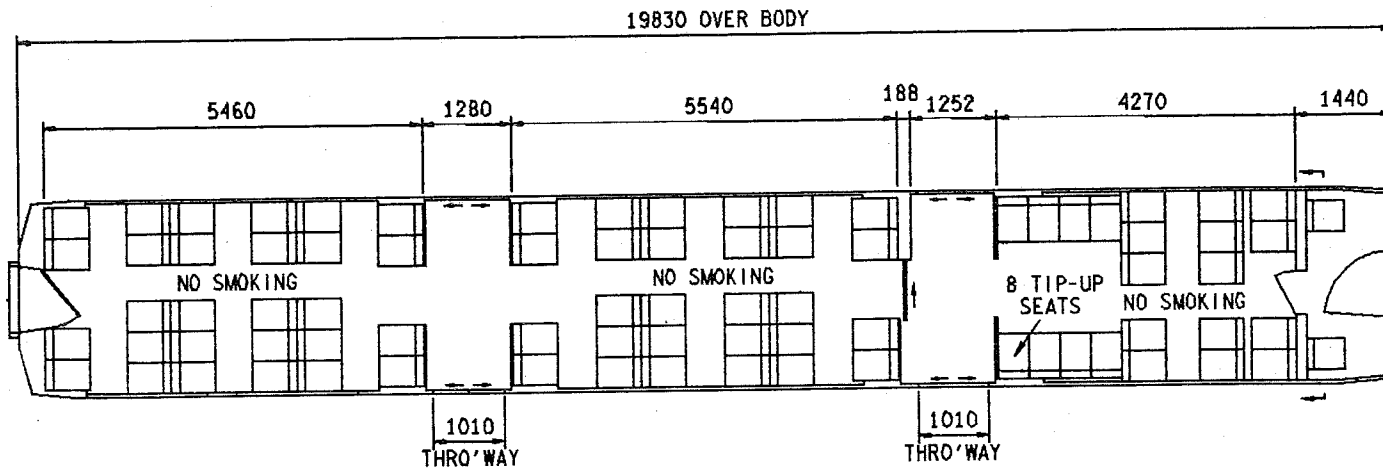
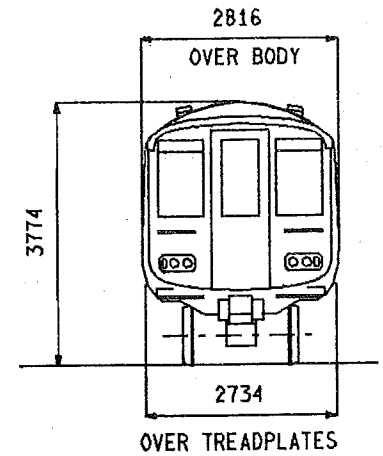
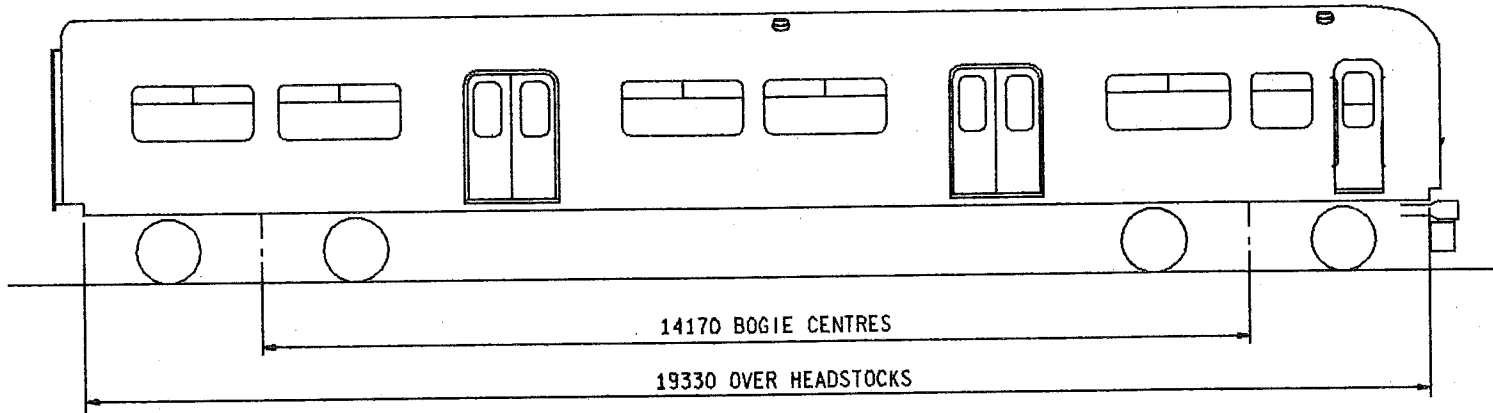

SEATS	78
TOILETS	-
COMPARTMENTS	-
GUARDS COMPARTMENTS	-
VENTILATION	-
CATERING EQUIPMENT	-

ISSUE 1 DATE JAN 88

EE 234

BASIC TYPE

BRAKES
BOGIE/SUSPENSION
BODY CONSTRUCTION
COUPLINGS
TRAIN HEATING
MAX.SPEED M.P.H.
MIN.RAD.CURVE CHAINS
LIGHTING
TARE WEIGHT TONNES
GANGWAYS
A.W.S.
TRAIN COMMUNICATION
BUFFERS

ELECTRO-PNEUMATIC
T3-7a & T3-7b(ONE OF EACH)
STEEL
AUTOMATIC TIGHTLOCK OUTER END-BAR INNER END
ELECTRIC(BR)
100
3.5
FLUORESCENT
28.1
FLEXIBLE DIAPHRAGM/RIGID(GRP)INNER END
FITTED
DRIVER/SIGNAL BOX-DRIVER/GUARD-PUBLIC ADDRESS WITH TRANSMITTER
NOT FITTED

ALTERNATIVES

TRACTION DATA FOR MULTIPLE UNITS

EMU- CROSS LONDON SERVICES.INTRODUCED 1987
VOLTAGE 25 KV A.C.OVERHEAD & 750V D.C.THIRD RAIL

BASIC TYPE

EE 234 OA

VARIANTS

NONE

DRIVING TRAILER SECOND

CLASS 317/1

DTS(B)

EE 235

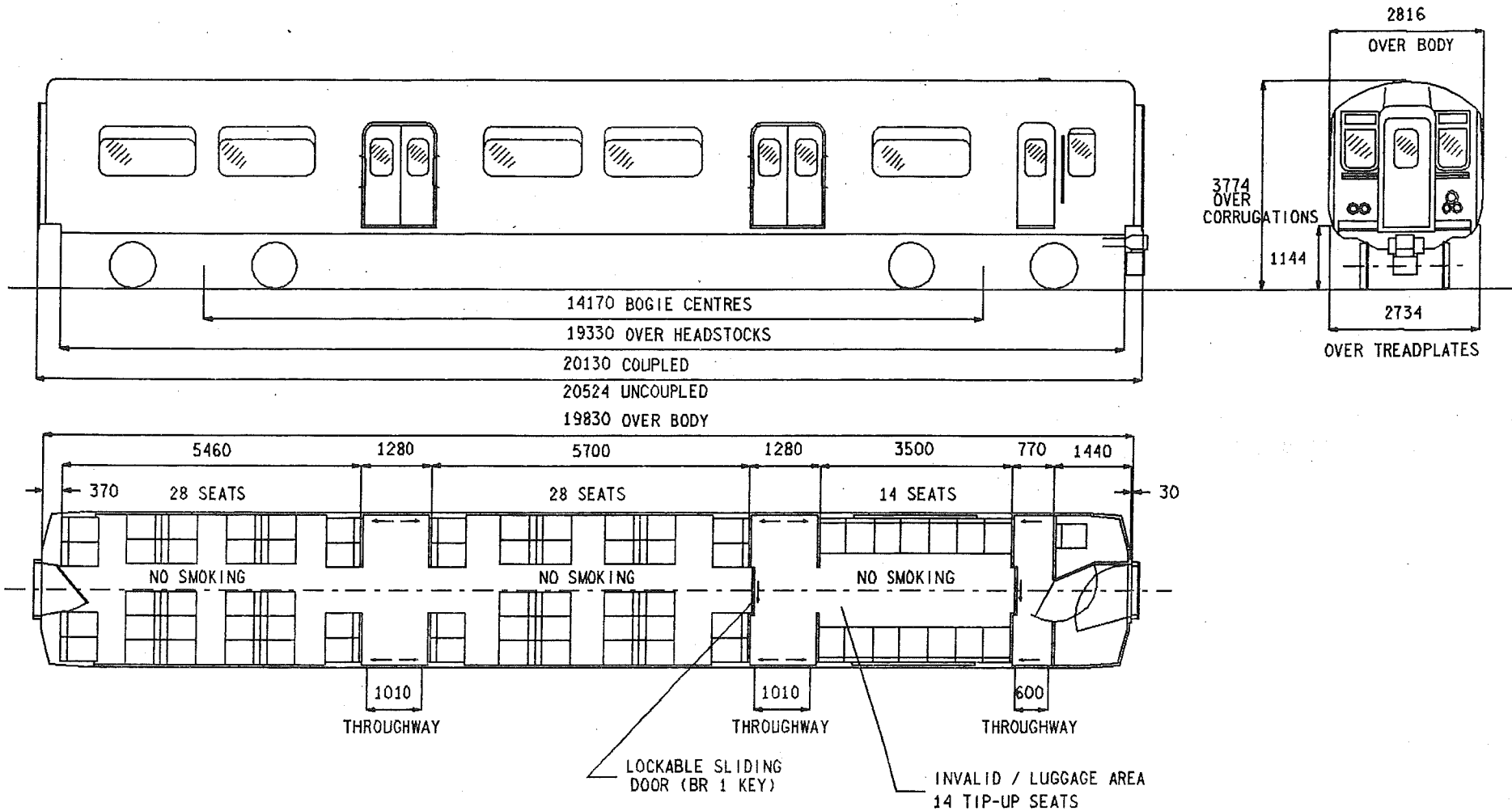

SEATS	70
TOILETS	-
COMPARTMENTS	-
GUARDS COMPARTMENTS	CAB WHEN TRAILING
VENTILATION	PRESSURE
CATERING EQUIPMENT	-

ORIGINAL DIAGRAMS FOR REFERENCE:-
BR 463

ISSUE DATE
1 APR 86

EE 235

BRAKES
BOGIE/SUSPENSION
BODY CONSTRUCTION
COUPLINGS
TRAIN HEATING
MAX. SPEED M.P.H.
MIN. RAD. CURVE CHAINS
LIGHTING
TARE WEIGHT TONNES
GANGWAYS

A.W.S.
TRAIN COMMUNICATION
BUFFERS

BASIC TYPE

ELECTRO-PNEUMATIC
BT13a & BT13b (ONE OF EACH)
STEEL
AUTOMATIC TIGHTLOCK OUTER END-BAR INNER END
ELECTRIC (BR) WITH PRESSURE VENTILATION & HEATING
90
3.5
FLUORESCENT & TUNGSTEN
29.5
CENTRALLY SUPPORTED-SWIVELLING-FLEXIBLE DIAPHRAGM-STEEL FACE PLATE
OUTER END-FLEXIBLE DIAPHRAGM/RIGID (GRP) INNER END
FITTED
DRIVER/SIGNAL BOX-DRIVER/GUARD-PUBLIC ADDRESS WITH TRANSMITTER
NOT FITTED

ALTERNATIVES

TRACTION DATA FOR MULTIPLE UNITS

EMU- ST. PANCRAS & MOORGATE TO BEDFORD. TRANSFERED TO W.C.M.L. 1986.
VOLTAGE 25 KV A.C. OVERHEAD

BASIC TYPE

EE 235 0A

VARIANTS

NONE

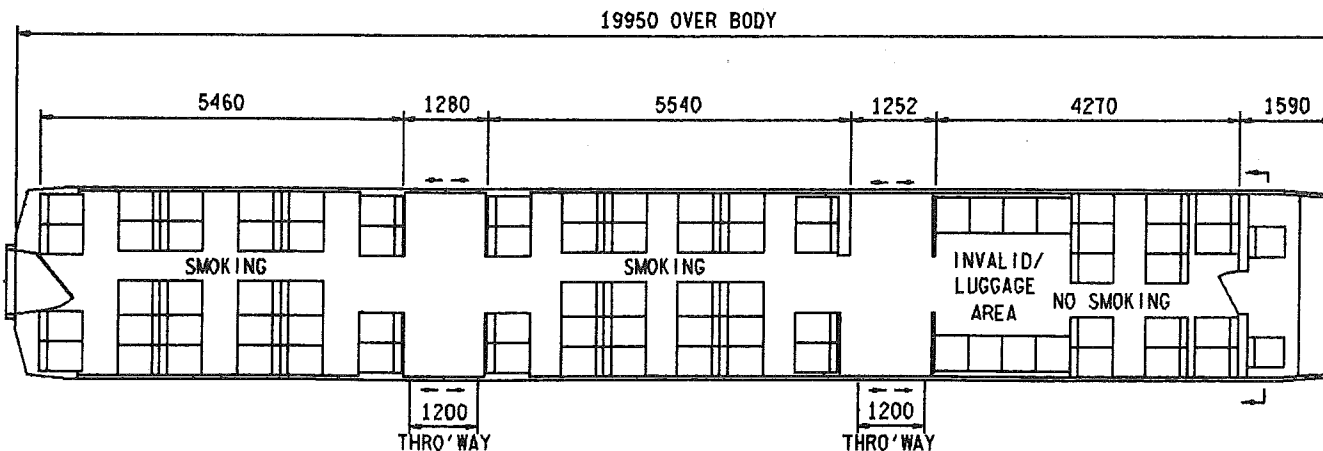
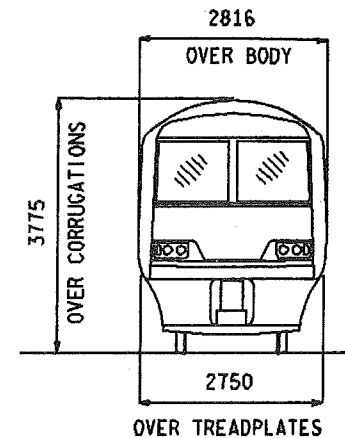
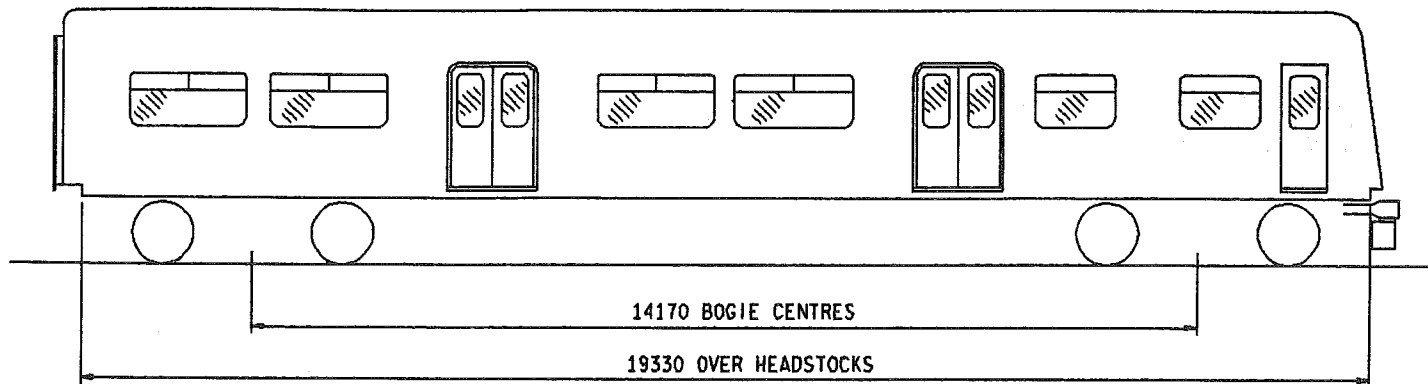

- SEATS 78
- TOILETS -
- COMPARTMENTS -
- GUARDS COMPARTMENTS -
- VENTILATION -
- CATERING EQUIPMENT -

ISSUE 1 DATE OCT 88

EE 236

BRAKES
BOGIE/SUSPENSION
BODY CONSTRUCTION
COUPLINGS
TRAIN HEATING
MAX.SPEED M.P.H.
MIN.RAD.CURVE METRES
LIGHTING
TARE WEIGHT TONNES
GANGWAYS
A.W.S.
TRAIN COMMUNICATION
BUFFERS

BASIC TYPE

ELECTRO-PNEUMATIC
T3-7I & T3-7J(ONE OF EACH)
STEEL
AUTOMATIC TIGHTLOCK OUTER END-BAR INNER END
ELECTRIC(BR)
100
71
FLUORESCENT
29,1
FLEXIBLE DIAPHRAGM/RIGID(GRP)INNER END
FITTED
DRIVER/GUARD PUBLIC ADDRESS WITH TRANSMITTER
NOT FITTED

ALTERNATIVES

TRACTION DATA FOR MULTIPLE UNITS

EMU- ANGLIA-ELECTRICS INTRODUCED 1988/89
VOLTAGE 25 KV A.C.OVERHEAD

BASIC TYPE

EE 236 DA

VARIANTS

NONE

DRIVING TRAILER STANDARD

CLASS 310/1

DTS

EE 237

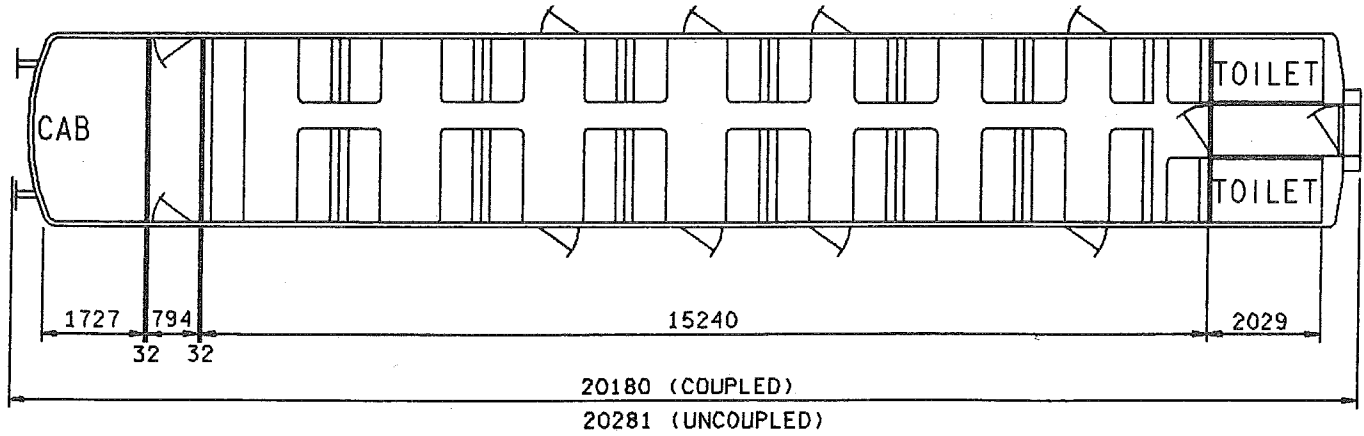
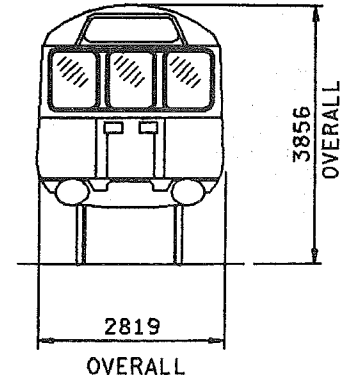
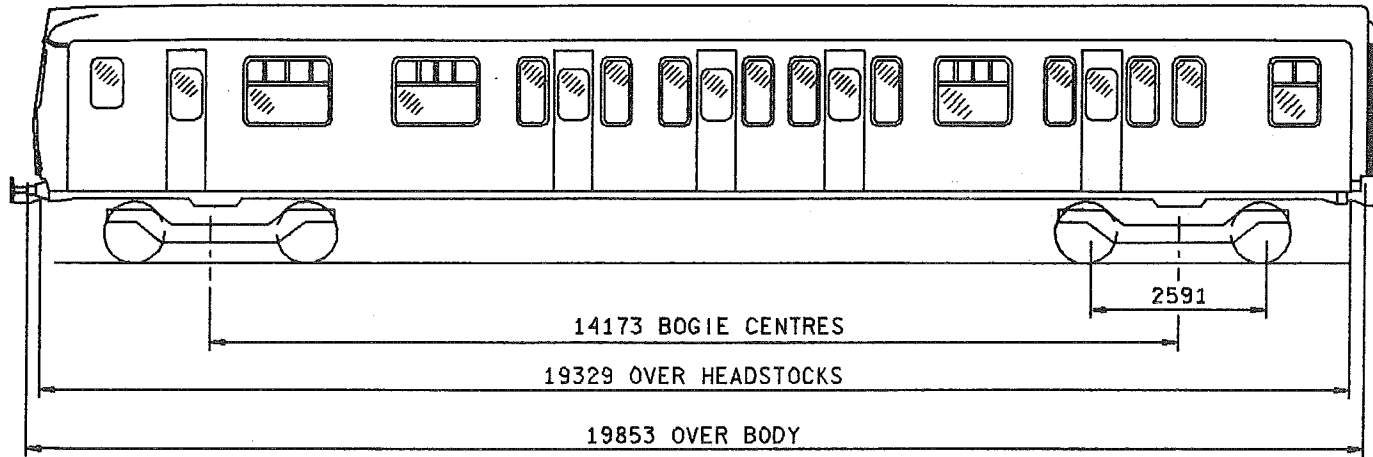

SEATS	75
TOILETS	2
COMPARTMENTS	-
GUARDS COMPARTMENTS	-
VENTILATION	-
CATERING EQUIPMENT	-

ISSUE DATE
1 AUG '88

EE 237

BRAKES
BOGIE/SUSPENSION
BODY CONSTRUCTION
COUPLINGS

TRAIN HEATING
MAX.SPEED M.P.H.
MIN.RAD.CURVE CHAINS
LIGHTING
TARE WEIGHT TONNES
GANGWAYS
TRAIN COMMUNICATION
BUFFERS

BASIC TYPE

ELECTRO PNEUMATIC
B4/AM10 DT
STEEL
AUTOMATIC DROPHEAD (BUCKEYE) OUTER END- AUTOMATIC SOLID SHANK
(BUCKEYE) INNER END
ELECTRIC(BR)
75
3.5
TUNGSTEN
34.5
EXPRESS ELECTRIC INNER END ONLY
PUBLIC ADDRESS
RETRACTABLE SPINDLE (559x356 OVAL) OUTER END ONLY

ALTERNATIVES

TRACTION DATA FOR MULTIPLE UNITS

EMU- EUSTON-BIRMINGHAM-MANCHESTER & LIVERPOOL INTRODUCED 1966, FACELIFTED 1985.
VOLTAGE 25 KV A.C.OVERHEAD.

BASIC TYPE

EE 237 OA

VARIANTS

NONE

DRIVING TRAILER SECOND

CLASS 485
486

DTS

EE 260

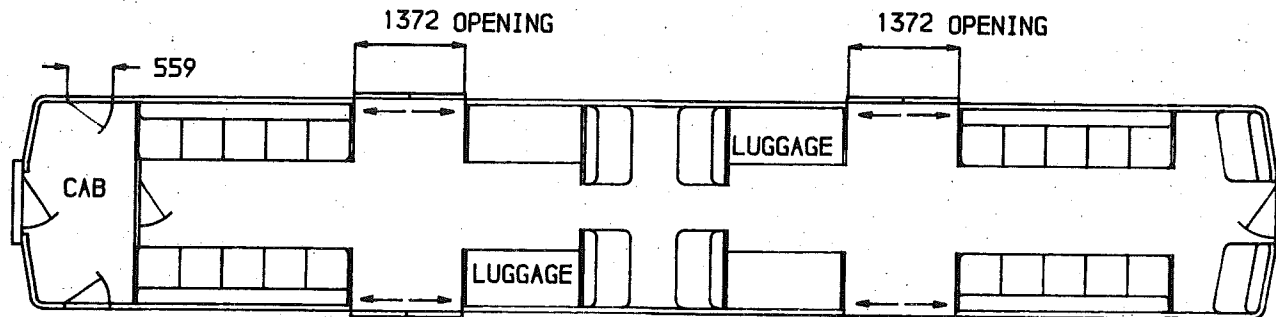
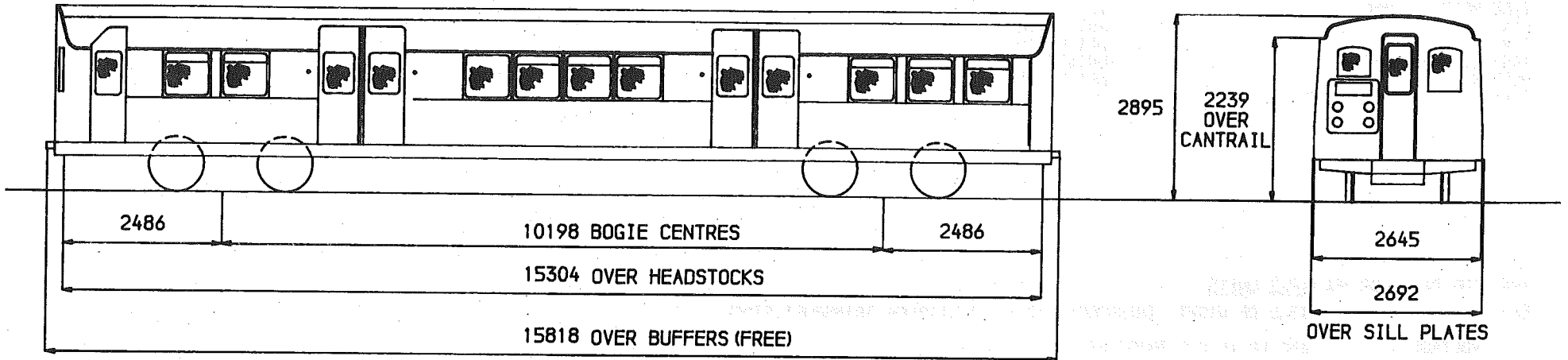

SEATS 38
TOILETS -
COMPARTMENTS -
GUARDS COMPARTMENTS -
VENTILATION -
CATERING EQUIPMENT -

ORIGINAL DIAGRAMS FOR REFERENCE.-
S.R. 850

ISSUE 1 DATE SEP' 80

EE 260

BASIC TYPE

BRAKES
BOGIE/SUSPENSION
BODY CONSTRUCTION
COUPLINGS
TRAIN HEATING
MAX. SPEED M. P. H.
MIN. RAD. CURVE CHAINS
LIGHTING
TARE WEIGHT TONNES
GANGWAYS
A. V. S.
TRAIN COMMUNICATION
BUFFERS
S. R. DESIGN REFERENCE CODE

ELECTRO PNEUMATIC
EX. LONDON TRANSPORT
STEEL UNDERFRAME, BODY & ROOF, WOODEN BODY FRAMING
EX. LONDON TRANSPORT
ELECTRIC (BR)
NO RECORD
3.5
ELECTRIC
17
NOT FITTED
NOT FITTED
DRIVER/GUARD
NOT FITTED
DAE

ALTERNATIVES

TRACTION DATA FOR MULTIPLE UNITS

EMU- ISLE OF WIGHT INTRODUCED 1967 - EX. LONDON TRANSPORT STOCK
VOLTAGE 630 VOLTS D. C. THIRD RAIL

BASIC TYPE

EE 260 0A

VARIANTS

NONE

DRIVING TRAILER SECOND

CLASS 416/2

DTS

EE 264

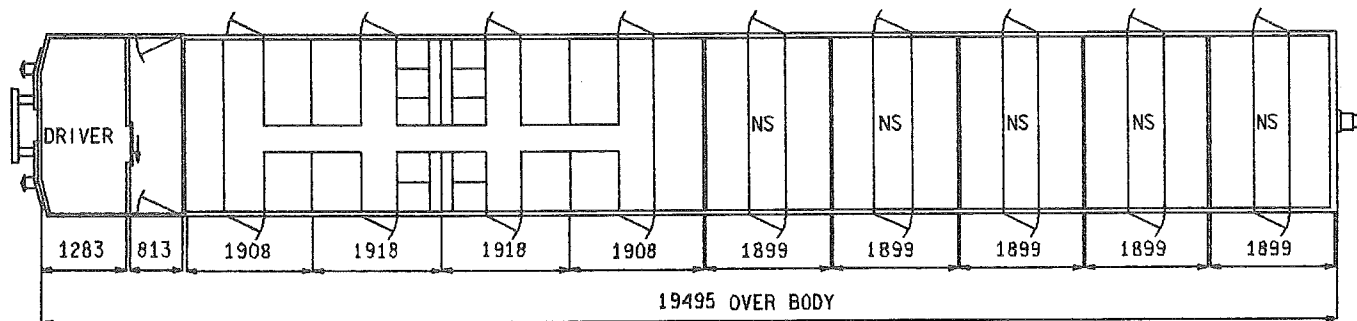
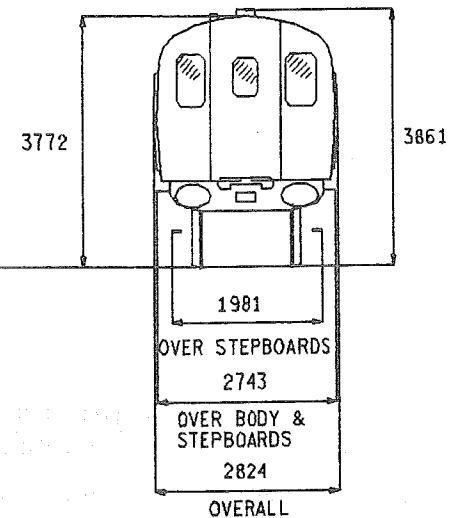
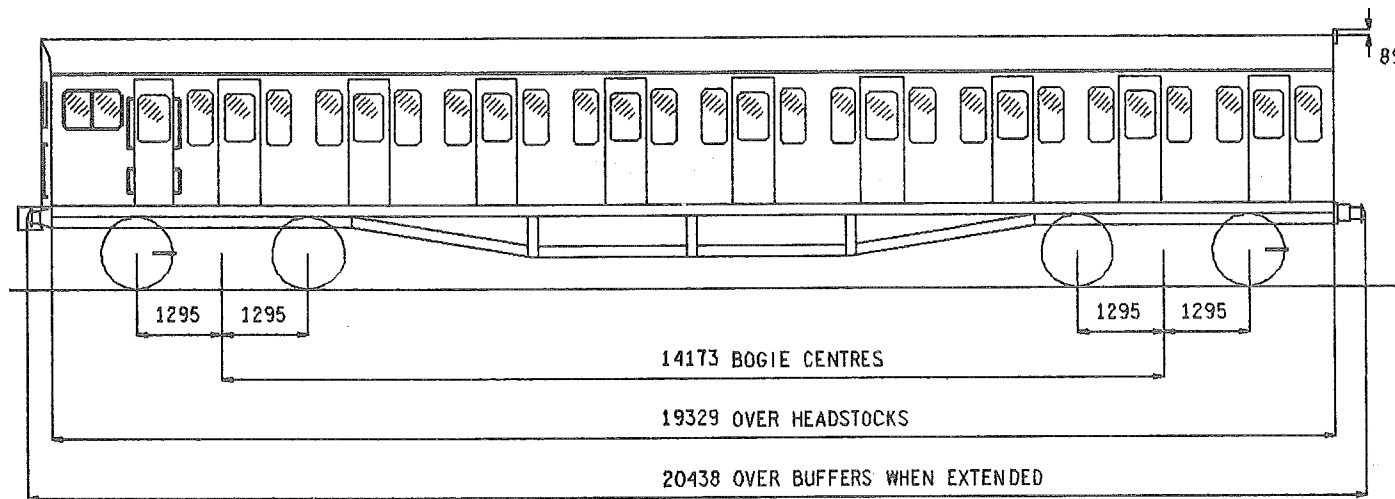

NS - NON SMOKING

SEATS	102
TOILETS	-
COMPARTMENTS	5 PLUS 1 SALOON
GUARDS COMPARTMENTS	-
VENTILATION	-
CATERING EQUIPMENT	-

ORIGINAL DIAGRAMS FOR REFERENCE:-
BR 420

ISSUE 3 DATE NOV '84

EE 264

BASIC TYPE

ALTERNATIVES

BRAKES
BOGIE/SUSPENSION
BODY CONSTRUCTION
COUPLINGS
TRAIN HEATING
MAX.SPEED M.P.H.
MIN.RAD.CURVE CHAINS
LIGHTING
TARE WEIGHT TONNES
GANGWAYS
A.W.S.
TRAIN COMMUNICATION
BUFFERS
S.R.DESIGN REFERENCE CODE

ELECTRO PNEUMATIC
S.R.MK 3D UNPOWERED
STEEL
AUTOMATIC DROPHEAD(BUCKEYE) OUTER END-3 LINK INNER END
ELECTRIC(BR)
75
3.5
TUNGSTEN
30.5
NOT FITTED
NOT FITTED
DRIVER/GUARD
RETRACTABLE SPINDLE-559 X 356 OVAL OUTER END-CENTRE INNER END
DV

32.5

FITTED

TRACTION DATA FOR MULTIPLE UNITS

EMU- INTRODUCED 1954
VOLTAGE 750/850 VOLTS D.C.THIRD RAIL

BASIC TYPE

EE 264 0A

VARIANTS

1A A.W.S.FITTED,TARE 32.5.

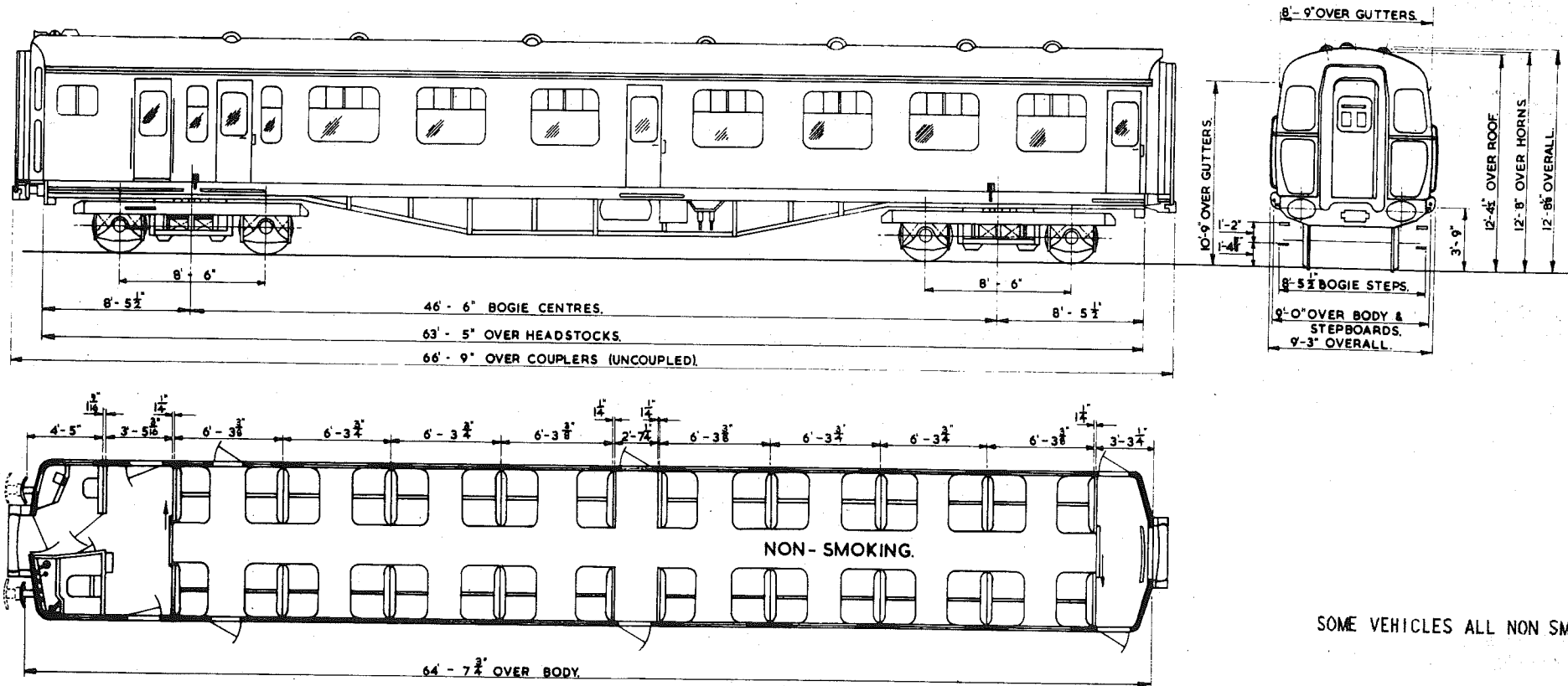

NON - SMOKING.

SOME VEHICLES ALL NON SMOKING

SEATS	64
TOILETS	-
COMPARTMENTS	-
GUARDS COMPARTMENTS	-
VENTILATION	-
CATERING EQUIPMENT	-

ORIGINAL DIAGRAMS FOR REFERENCE:-
BR 900A

ISSUE 4 DATE AUG 85

EE 266

BRAKES
BOGIE/SUSPENSION
BODY CONSTRUCTION
COUPLINGS

TRAIN HEATING
MAX.SPEED M.P.H.
MIN.RAD.CURVE CHAINS
LIGHTING
TARE WEIGHT TONNES
GANGWAYS
A.W.S.
TRAIN COMMUNICATION
BUFFERS
S.R.DESIGN REFERENCE CODE

BASIC TYPE

ELECTRO PNEUMATIC
B5(S.R.)
STEEL
AUTOMATIC DROPHEAD(BUCKEYE) OUTER END-AUTOMATIC SOLID SHANK
(ALLIANCE NO.2) INNER END
ELECTRIC(BR)
90
3.5
TUNGSTEN
32.5
EXPRESS ELECTRIC
FITTED
DRIVER/GUARD
RETRACTABLE SPINDLE-559 X 356 OVAL OUTER END ONLY
FC

ALTERNATIVES

FC 1A

TRACTION DATA FOR MULTIPLE UNITS

EMU- TRAILER UNIT. INTRODUCED 1966 AS CLASS 491, RECLASSED 1984.

BASIC TYPE

EE 266 0A

VARIANTS

1A S.R.DESIGN REFERENCE CODE FC 1A.
2B MODIFIED INTERIOR & LIGHTS.

DRIVING TRAILER SECOND

CLASS 416/3

DTS

EE 269

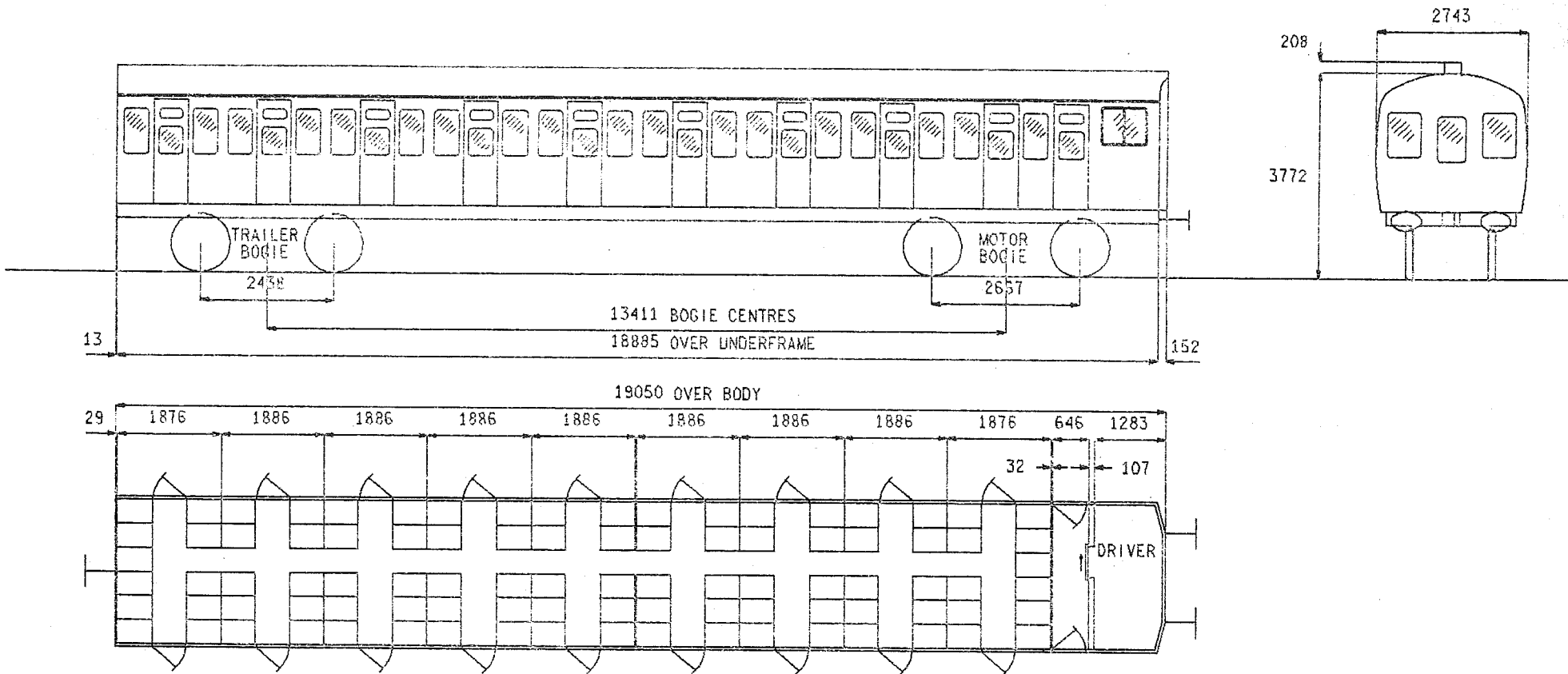

- SEATS 92
- TOILETS -
- COMPARTMENTS -
- GUARDS COMPARTMENTS -
- VENTILATION -
- CATERING EQUIPMENT -

ISSUE 2 DATE JAN 84

EE 269

BRAKES
BOGIE/SUSPENSION
BODY CONSTRUCTION
COUPLINGS
TRAIN HEATING
MAX.SPEED M.P.H.
MIN.RAD.CURVE CHAINS
LIGHTING
TARE WEIGHT TONNES
GANGWAYS
A.W.S.
TRAIN COMMUNICATION
BUFFERS
S.R.DESIGN REFERENCE CODE

BASIC TYPE

ELECTRO PNEUMATIC
SR STANDARD 229X114
STEEL
AUTOMATIC DROPHEAD(BUCKEYE) OUTER END-3 LINK INNER END
ELECTRIC(BR)
75
3.5
FLUORESCENT & TUNGSTEN
30
NOT FITTED
FITTED
DRIVER GUARD & PUBLIC ADDRESS
RETRACTABLE SPINDLE-559X356-OUTER END-CENTRE INNER END
DAL

ALTERNATIVES

TRACTION DATA FOR MULTIPLE UNITS

EMU- INTRODUCED 1959, REFURBISHED 1980/81, RECLASSED 1984.
VOLTAGE 750/850 VOLTS D.C. THIRD RAIL

BASIC TYPE

EE 269 0A

VARIANTS

NONE

DRIVING TRAILER SECOND

CLASS 416/4

DTS

EE 271

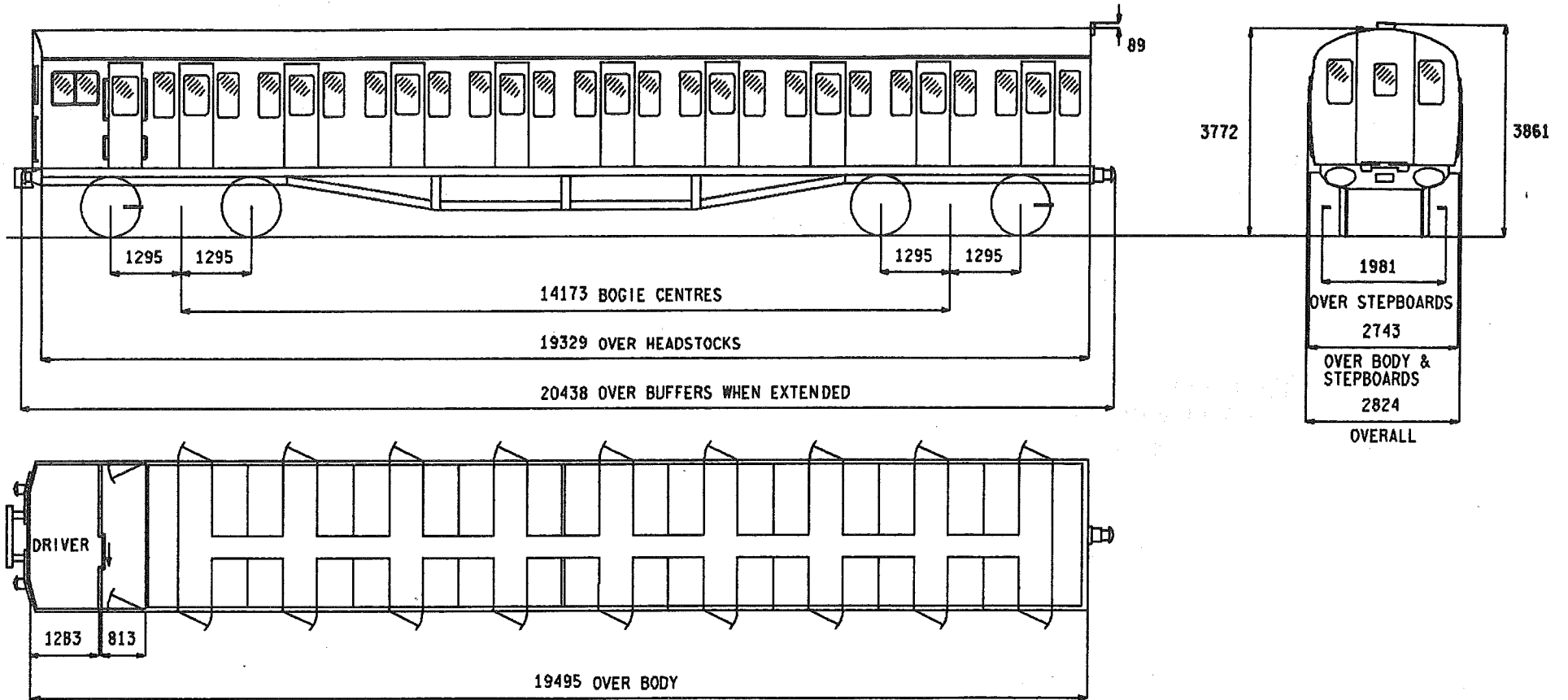

SEATS	92
TOILETS	-
COMPARTMENTS	-
GUARDS COMPARTMENTS	-
VENTILATION	-
CATERING EQUIPMENT	-

ISSUE	DATE
2	OCT '88

EE 271

BASIC TYPE

ALTERNATIVES

BRAKES
BOGIE/SUSPENSION
BODY CONSTRUCTION
COUPLINGS
TRAIN HEATING
MAX. SPEED M.P.H.
MIN. RAD. CURVE CHAINS
LIGHTING
TARE WEIGHT TONNES
GANGWAYS
A.W.S.
TRAIN COMMUNICATION
BUFFERS
S.R. DESIGN REFERENCE CODE

ELECTRO PNEUMATIC
SR MK 3D UNPOWERED
STEEL
AUTOMATIC DROPHEAD(BUCKEYE) OUTER END-3 LINK INNER END
ELECTRIC(BR)
75
3.5
FLUORESCENT & TUNGSTEN
30.5
NOT FITTED
FITTED
DRIVER GUARD & PUBLIC ADDRESS
RETRACTABLE SPINDLE-559X356-OUTER END-CENTRE INNER END
DAM 1A

TRACTION DATA FOR MULTIPLE UNITS

EMU- INTRODUCED 1954, REFURBISHED 1980/81
VOLTAGE 750/850 VOLTS D.C. THIRD RAIL

BASIC TYPE

EE 271 0A

VARIANTS

NONE

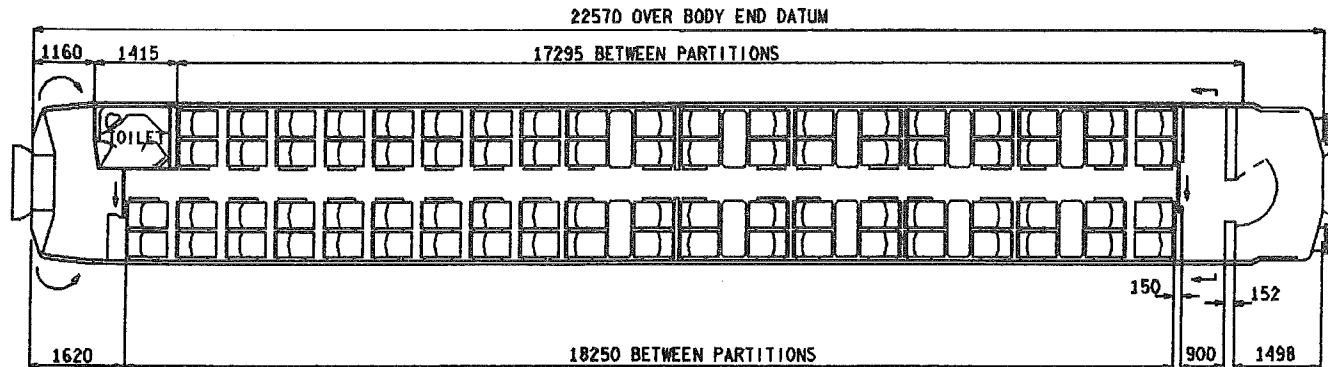
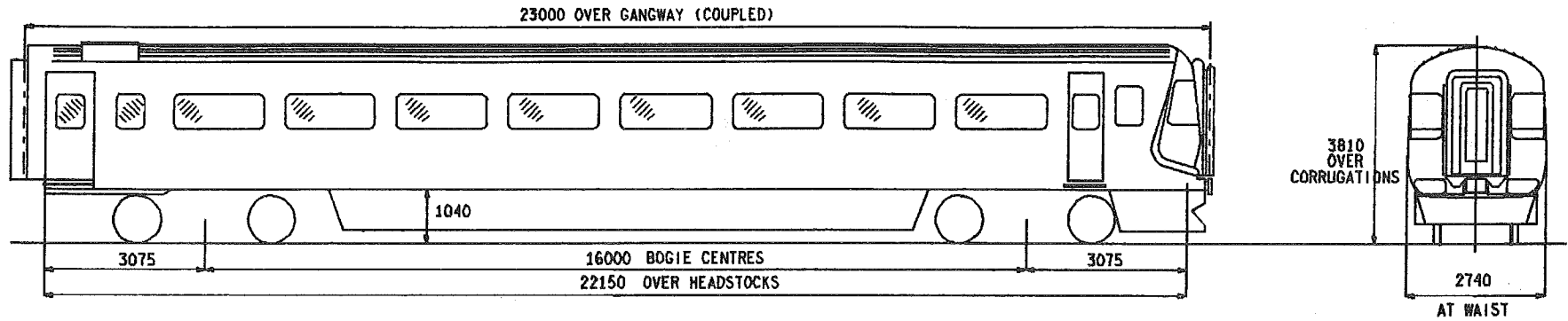

SEATS	78
TOILETS	1
COMPARTMENTS	-
GUARDS COMPARTMENTS	-
VENTILATION	FULL AIR CONDITIONING
CATERING EQUIPMENT	-

ISSUE DATE
1 JUL 88

EE 273

BRAKES
BOGIE/SUSPENSION
BODY CONSTRUCTION
COUPLINGS
TRAIN HEATING

MAX.SPEED M.P.H.
MIN.RAD.CURVE METRES
LIGHTING
TARE WEIGHT TONNES
GANGWAYS
TRAIN COMMUNICATION
BUFFERS

BASIC TYPE

ELECTRO-PNEUMATIC
T3-7 (BREL)
STEEL
AUTOMATIC DROPHEADBUCKEYE OUTER END-BAR INNER END
ELECTRIC(BR)FULL AIR CONDITIONING

100
90
FLUORESCENT & TUNGSTEN
34
CENTRALLY SUPPORTED-SWIVELLING-FLEXIBLE DIAPHRAGM-STEEL FACE PLATE
DRIVER/SIGNAL BOX-DRIVER/GUARD-PUBLIC ADDRESS WITH TRANSMITTER
RETRACTABLE SPINDLE- OUTER END ONLY

ALTERNATIVES

TRACTION DATA FOR MULTIPLE UNITS

EMU- WATERLOO-BOURNEMOUTH-WEYMOUTH.INTRODUCED 1988
VOLTAGE 750 VOLTS.D.C.THIRD RAIL

BASIC TYPE

EE 273 0A

VARIANTS

NONE

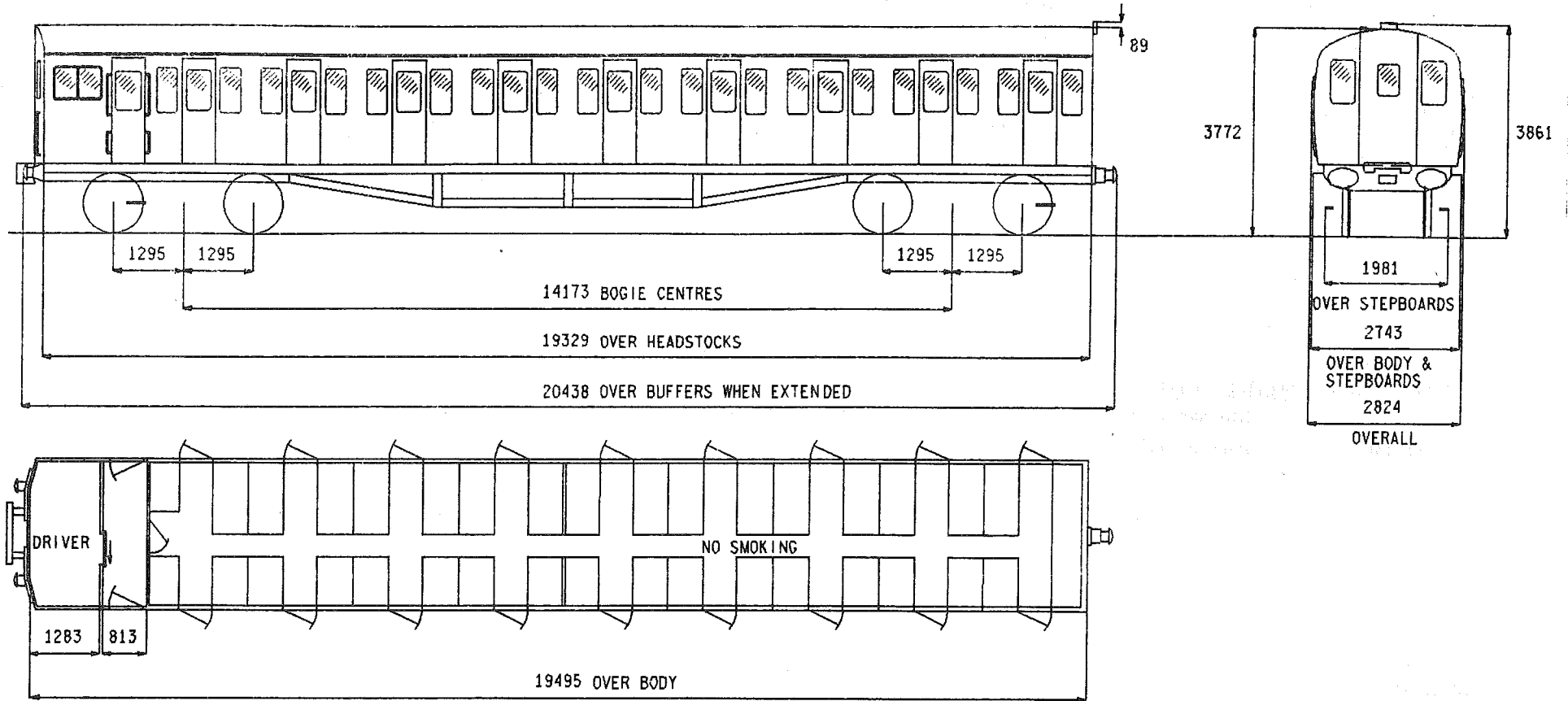

SEATS	90
TOILETS	-
COMPARTMENTS	-
GUARDS COMPARTMENTS	-
VENTILATION	-
CATERING EQUIPMENT	-

ISSUE 1 DATE OCT '88

EE 274

BASIC TYPE

ALTERNATIVES

BRAKES
BOGIE/SUSPENSION
BODY CONSTRUCTION
COUPLINGS
TRAIN HEATING
MAX.SPEED M.P.H.
MIN.RAD.CURVE CHAINS
LIGHTING
TARE WEIGHT TONNES
GANGWAYS
A.W.S.
TRAIN COMMUNICATION
BUFFERS
S.R.DESIGN REFERENCE CODE

ELECTRO PNEUMATIC
S.R.MK 3D UNPOWERED
STEEL
AUTOMATIC DROPHEAD(BUCKEYE) OUTER END-3 LINK INNER END
ELECTRIC(BR)
75
3.5
FLUORESCENT & TUNGSTEN
30.5
NOT FITTED
NOT FITTED
DRIVER/GUARD & PUBLIC ADDRESS
RETRACTABLE SPINDLE-559 X 356 OVAL OUTER END-CENTRE INNER END
DAM 3B

32.5

FITTED

TRACTION DATA FOR MULTIPLE UNITS

EMU- INTRODUCED 1954 REFURBISHED 1980 /1 CONVERTED TO REVENUE PROTECTED UNITS 1986
VOLTAGE 750/850 VOLTS D.C.THIRD RAIL

BASIC TYPE

EE 274 0A

VARIANTS

1B A.W.S.FITTED,TARE 32.5, EX TYNESIDE VEHICLE.

DRIVING TRAILER COMPOSITE

CLASS 312/0
312/1
312/2

DTC

EE 305

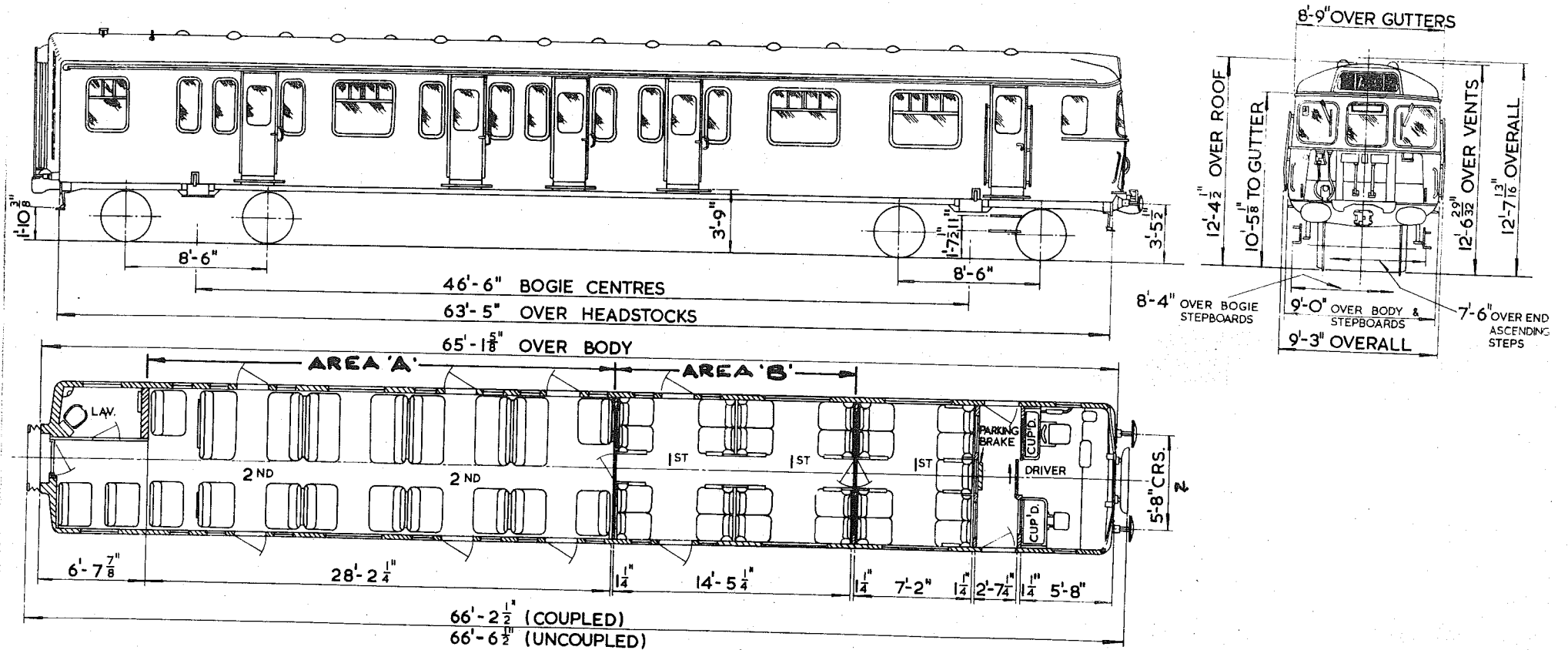

- | | |
|---------------------|---------------------------------|
| SEATS | 25 FIRST CLASS, 47 SECOND CLASS |
| TOILETS | 1 |
| COMPARTMENTS | - |
| GUARDS COMPARTMENTS | - |
| VENTILATION | - |
| CATERING EQUIPMENT | - |

ORIGINAL DIAGRAMS FOR REFERENCE:-
BR 461

ISSUE 4 DATE MAR 87

EE 305

BASIC TYPE

BRAKES
BOGIE/SUSPENSION
BODY CONSTRUCTION
COUPLINGS

TRAIN HEATING
MAX. SPEED M.P.H.
MIN. RAD. CURVE CHAINS
LIGHTING
TARE WEIGHT TONNES
GANGWAYS
A.W.S.
TRAIN COMMUNICATION
BUFFERS
VOLTAGE EQUIPMENT
SMOKING ACCOMMODATION

ELECTRO PNEUMATIC
BT8 & BT8a ONE OF EACH
STEEL
AUTOMATIC DROPHEAD (BUCKEYE) OUTER END, AUTOMATIC SOLID SHANK
(ALLIANCE NO 2) INNER END
ELECTRIC (BR)
CLASS 312/0 & 312/1 90, CLASS 312/2 75
3.5
FLUORESCENT & TUNGSTEN
33
BR STANDARD MK 2
FITTED
NOT FITTED
RETRACTABLE SPINDLE-559 X 356-OUTER END ONLY
25 KV A.C.
AREAS A & B NON SMOKING

ALTERNATIVES

25 & 6.25 KV A.C.
AREA A SMOKING

TRACTION DATA FOR MULTIPLE UNITS

EMU- CLASS 312/0 GREAT NORTHERN OUTER SUBURBAN - CLASS 312/1 GREAT EASTERN OUTER SUBURBAN - CLASS 312/2 LONDON MIDLAND OUTER SUBURBAN
INTRODUCED 1975.
VOLTAGE 25 KV A.C. OVERHEAD OR 25 & 6.25 KV A.C. OVERHEAD - SEE VARIANTS

BASIC TYPE

EE 305 1B - CLASS 312/0

VARIANTS

- 1C CLASS 312/2, AREA A SMOKING, AREA B NON SMOKING.
- 2B CLASS 312/1, VOLTAGE EQUIPMENT 25 & 6.25 KV A.C., AREA A NON SMOKING, AREA B NON SMOKING.
- 1D CLASS 312/0 FACELIFTED.

DRIVING TRAILER COMPOSITE

CLASS 310

DTC

EE 306

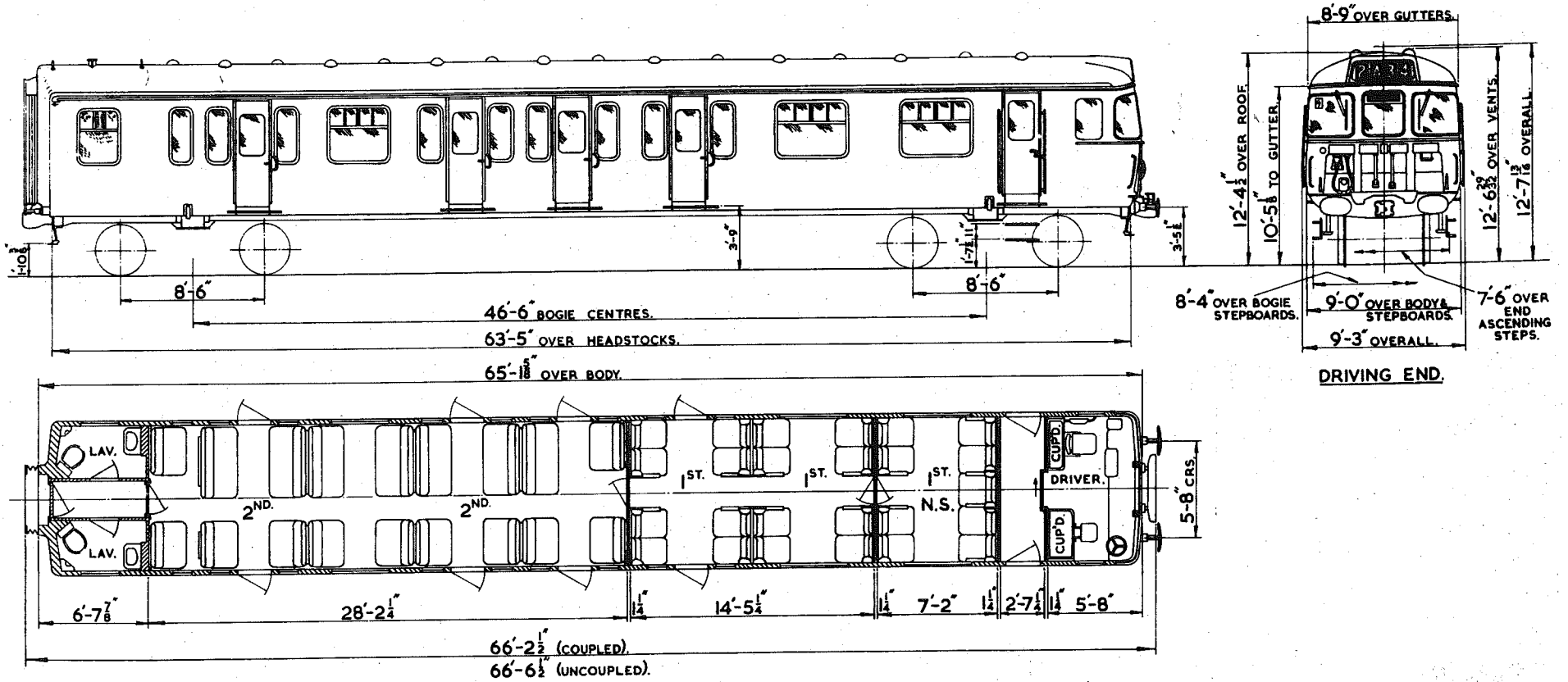

SEATS	25	FIRST CLASS	43	SECOND CLASS
TOILETS	2			
COMPARTMENTS	-			
GUARDS COMPARTMENTS	-			
VENTILATION	-			
CATERING EQUIPMENT	-			

ORIGINAL DIAGRAMS FOR REFERENCE:-
BR 454

ISSUE 2 DATE DEC 85

EE 306

BRAKES
BOGIE/SUSPENSION
BODY CONSTRUCTION
COUPLINGS

TRAIN HEATING
MAX.SPEED M.P.H.
MIN.RAD.CURVE CHAINS
LIGHTING
TARE WEIGHT TONNES
GANGWAYS
A.W.S.
TRAIN COMMUNICATION
BUFFERS

BASIC TYPE

ELECTRO PNEUMATIC
B4/AM10 DT
STEEL
AUTOMATIC DROPHEAD(BUCKEYE) OUTER END-AUTOMATIC SOLID SHANK(BUCKEYE)
INNER END
ELECTRIC(BR)
75
3.5
TUNGSTEN
34.5
EXPRESS ELECTRIC INNER END ONLY
FITTED
NOT FITTED
RETRACTABLE SPINDLE(559X356 OVAL) OUTER END ONLY

ALTERNATIVES

PUBLIC ADDRESS

TRACTION DATA FOR MULTIPLE UNITS

EMU- EUSTON-BIRMINGHAM-MANCHESTER & LIVERPOOL. INTRODUCED 1966.
VOLTAGE 25 KV A.C.OVERHEAD

BASIC TYPE

EE 306 0A

VARIANTS

1B FACELIFTED,PUBLIC ADDRESS FITTED.

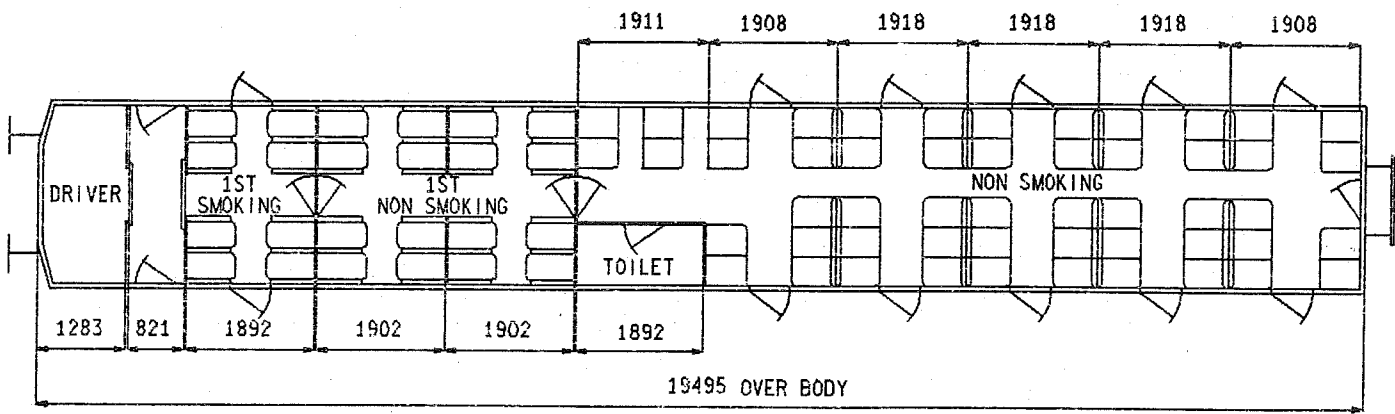
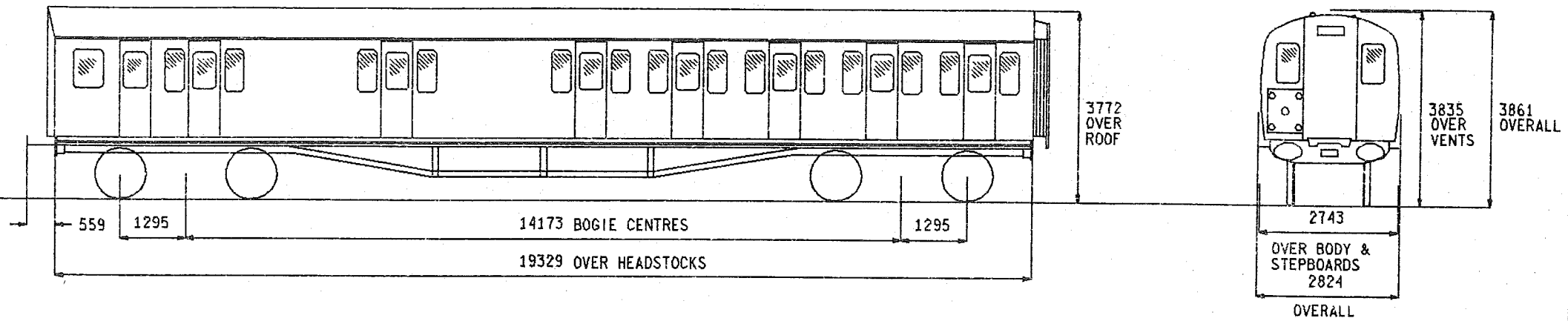

- | | |
|---------------------|---------------------------------|
| SEATS | 24 FIRST CLASS, 52 SECOND CLASS |
| TOILETS | 1 |
| COMPARTMENTS | - |
| GUARDS COMPARTMENTS | - |
| VENTILATION | - |
| CATERING EQUIPMENT | - |

ISSUE 2 DATE MAR 87

EE 307

BRAKES
BOGIE/SUSPENSION
BODY CONSTRUCTION
COUPLINGS

TRAIN HEATING
MAX. SPEED M.P.H.
MIN. RAD. CURVE CHAINS
LIGHTING
TARE WEIGHT TONNES
GANGWAYS
A.W.S.
TRAIN COMMUNICATION
BUFFERS

BASIC TYPE

ELECTRO PNEUMATIC
ET7
STEEL
AUTOMATIC DROPHEAD (BUCKEYE) OUTER END-AUTOMATIC SOLID SHANK
(BUCKEYE) INNER END
ELECTRIC (BR)
75
3.5
FLUORESCENT
33
PULLMAN WITH RIGID (GRP) INNER PANELS INNER END ONLY
FITTED
DRIVER/GUARD-PUBLIC ADDRESS
RETRACTABLE SPINDLE-559 X 356 OVAL OUTER END-CENTRE INNER END

ALTERNATIVES

B4

TRACTION DATA FOR MULTIPLE UNITS

GREAT EASTERN OUTER SUBURBAN. INTRODUCED 1956 FOR D.C. WORKING, REBUILT 1962 FOR A.C. WORKING, REFURBISHED 1981.
25 & 6.25 KV A.C. OVERHEAD

BASIC TYPE

EE 307 0A

VARIANTS

OB B4 BOGIES.

DRIVING TRAILER COMPOSITE

CLASS 321

DTC

EE 308

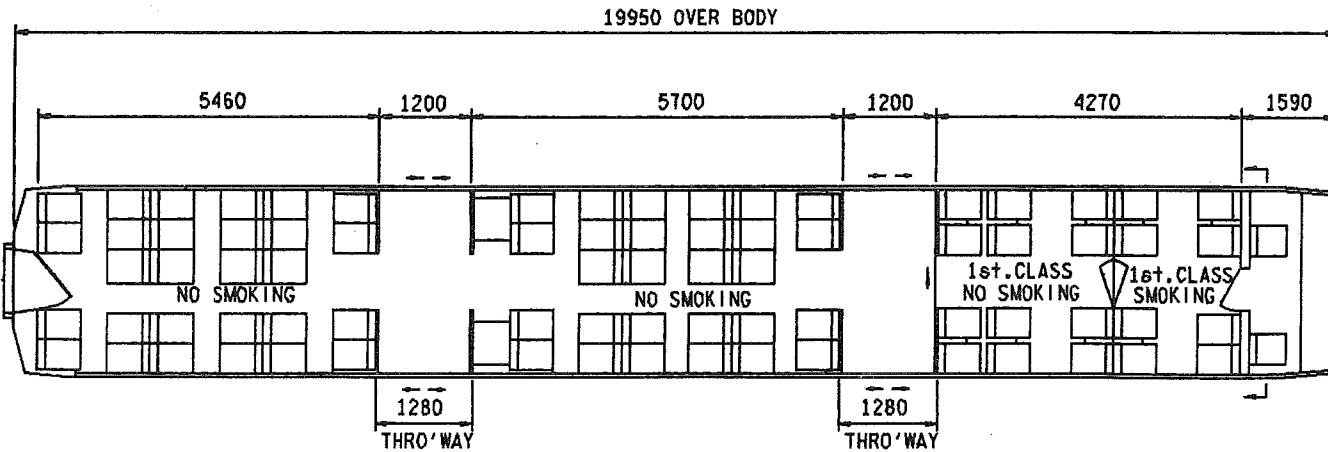
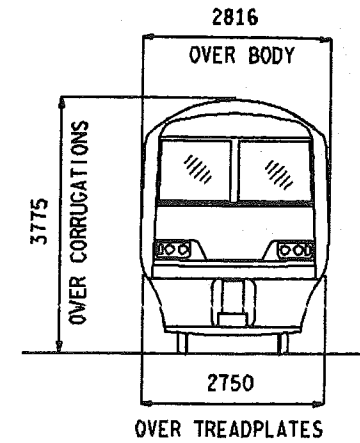
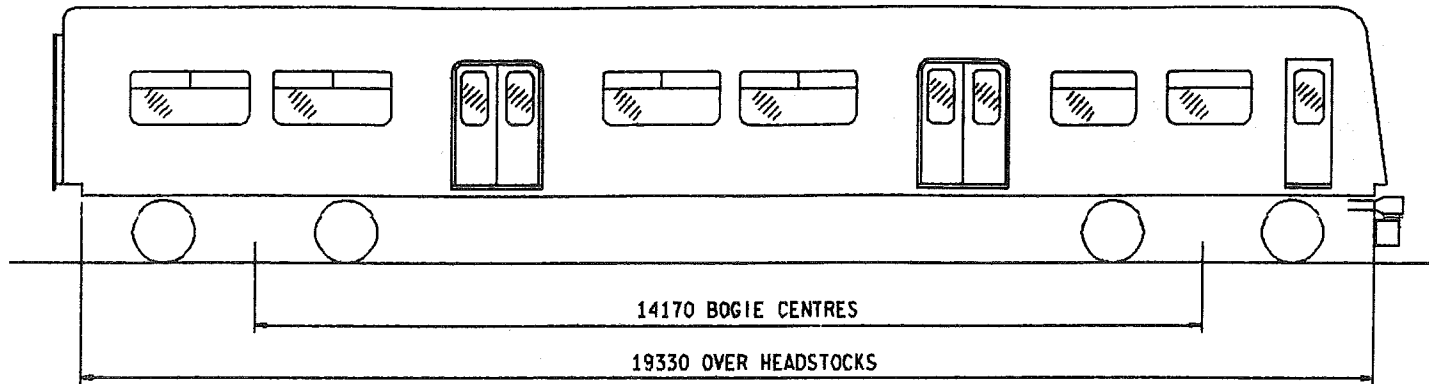

- SEATS 20 FIRST CLASS, 58 STANDARD
- TOILETS -
- COMPARTMENTS -
- GUARDS COMPARTMENTS -
- VENTILATION -
- CATERING EQUIPMENT -

ISSUE 1 DATE OCT 88

EE 308

BRAKES
BOGIE/SUSPENSION
BODY CONSTRUCTION
COUPLINGS
TRAIN HEATING
MAX. SPEED M.P.H.
MIN. RAD. CURVE METRES
LIGHTING
TARE WEIGHT TONNES
GANGWAYS
A.W.S.
TRAIN COMMUNICATION
BUFFERS

BASIC TYPE

ELECTRO-PNEUMATIC
T3-7J & T3-7K (ONE OF EACH)
STEEL
AUTOMATIC TIGHTLOCK OUTER END-BAR INNER END
ELECTRIC (BR)
100
71
FLUORESCENT
29.3
FLEXIBLE DIAPHRAGM/RIGID (GRP) INNER END
FITTED (BR/DUAL)
DRIVER/GUARD PUBLIC ADDRESS WITH TRANSMITTER
NOT FITTED

ALTERNATIVES

TRACTION DATA FOR MULTIPLE UNITS

EMJ- ANGLIA-ELECTRICS INTRODUCED 1988/89
VOLTAGE 25 KV A.C. OVERHEAD

BASIC TYPE

EE 308 0A

VARIANTS

NONE

DRIVING TRAILER COMPOSITE

CLASS 414/2
413/2

DTC

EE 361

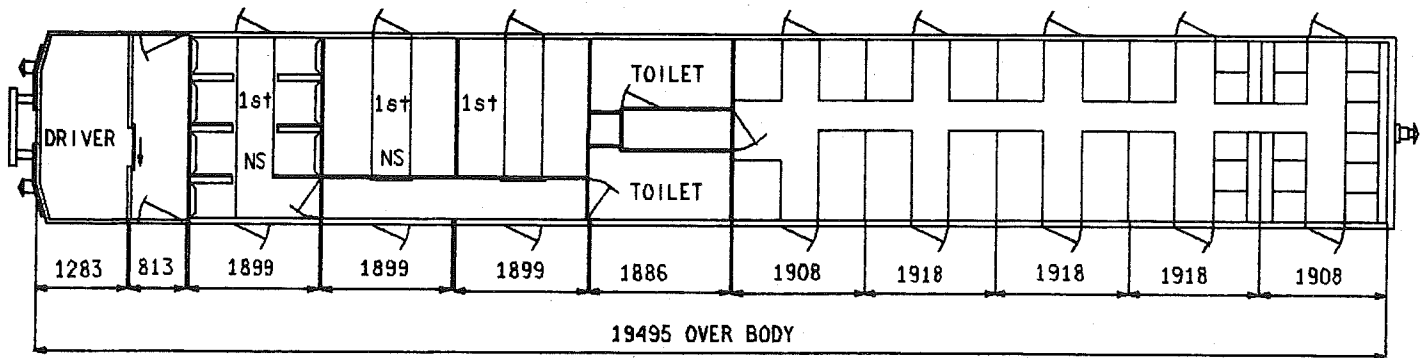
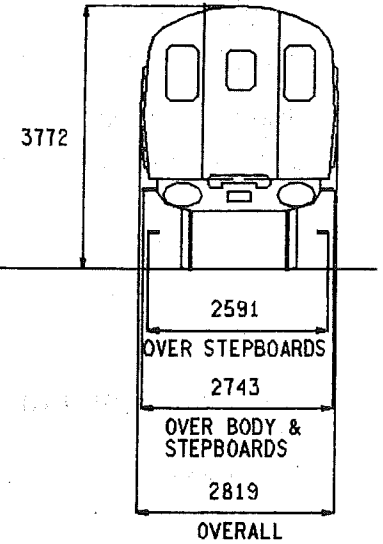
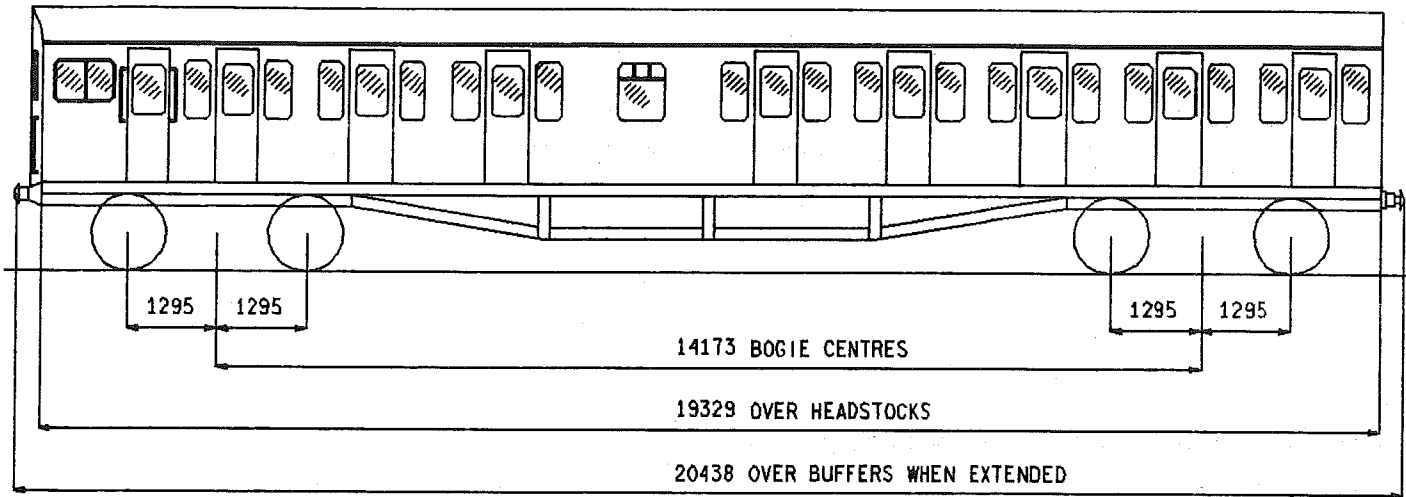

NS - NON SMOKING

ON SOME VEHICLES THIS SALOON IS NON SMOKING

- | | |
|---------------------|--|
| SEATS | 19 FIRST CLASS 50 SECOND CLASS |
| TOILETS | 2 |
| COMPARTMENTS | 3 FIRST CLASS PLUS 1 SECOND CLASS SALOON |
| GUARDS COMPARTMENTS | - |
| VENTILATION | - |
| CATERING EQUIPMENT | - |

ORIGINAL DIAGRAMS FOR REFERENCE:-
BR 441

ISSUE 4 DATE AUG 85

EE 361

BASIC TYPE

BRAKES
BOGIE/SUSPENSION
BODY CONSTRUCTION
COUPLINGS
TRAIN HEATING
MAX.SPEED M.P.H.
MIN.RAD.CURVE CHAINS
LIGHTING
TARE WEIGHT TONNES
GANGWAYS
A.W.S.
TRAIN COMMUNICATION
BUFFERS
S.R.DESIGN REFERENCE CODE

ELECTRO PNEUMATIC
S.R.MK 4 UNPOWERED
STEEL
AUTOMATIC DROPHEAD(BUCKEYE) OUTER END-3 LINK INNER END
ELECTRIC(BR)
90
3.5
TUNGSTEN
32.5
NOT FITTED
NOT FITTED
DRIVER/GUARD
RETRACTABLE SPINDLE-559 X 356 OVAL OUTER END-CENTRE INNER END
DX

ALTERNATIVES

FITTED

DX 1A

TRACTION DATA FOR MULTIPLE UNITS

EMU- INTRODUCED CLASS 414/2 1957, CLASS 413/2 AS 414/2 1957 RECLASSED 1983.
VOLTAGE 750/850 VOLTS D.C. THIRD RAIL

BASIC TYPE

EE 361 0A

VARIANTS

1A S.R.DESIGN REFERENCE CODE DX 1A.
2A A.W.S.FITTED.

DRIVING TRAILER COMPOSITE

CLASS 414/3
413/3

DTC

EE 362

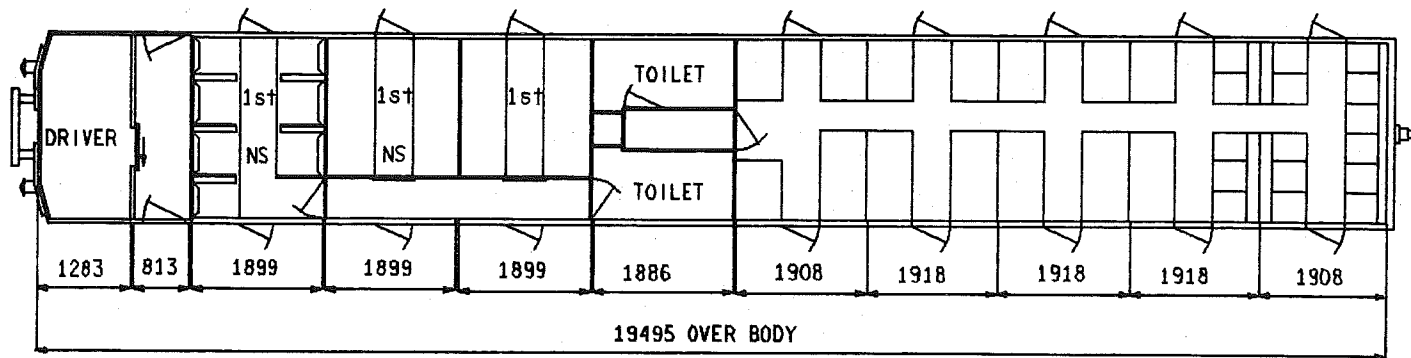
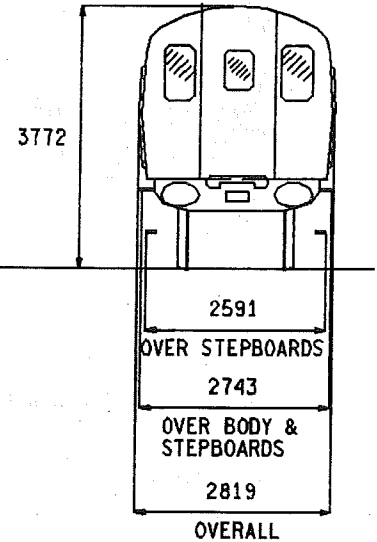
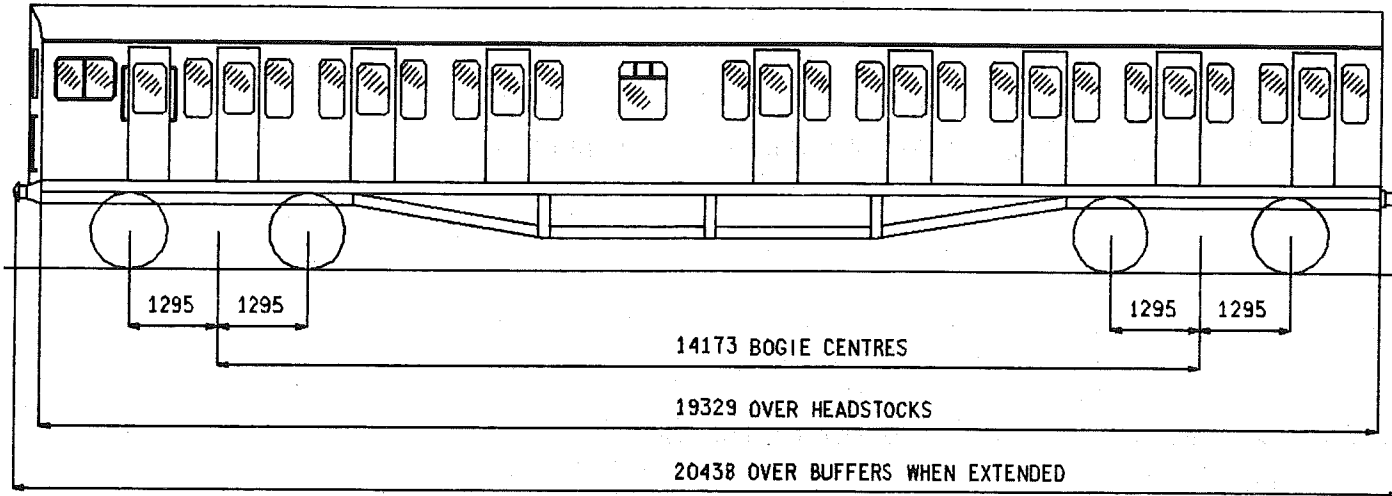

ON SOME VEHICLES THIS SALOON IS NON SMOKING

NS - NON SMOKING

SEATS
TOILETS
COMPARTMENTS
GUARDS COMPARTMENTS
VENTILATION
CATERING EQUIPMENT

19 FIRST CLASS 50 SECOND CLASS
2
3 FIRST CLASS PLUS 1 SECOND CLASS SALOON
-
-
-

ORIGINAL DIAGRAMS FOR REFERENCE:-
BR 441

ISSUE 4 DATE AUG 85

EE 362

BRAKES
BOGIE/SUSPENSION
BODY CONSTRUCTION
COUPLINGS
TRAIN HEATING
MAX. SPEED M.P.H.
MIN. RAD. CURVE CHAINS
LIGHTING
TARE WEIGHT TONNES
GANGWAYS
A.W.S.
TRAIN COMMUNICATION
BUFFERS
S.R. DESIGN REFERENCE CODE

BASIC TYPE

ELECTRO PNEUMATIC
S.R. MK 4 UNPOWERED
STEEL
AUTOMATIC DROPHEAD (BUCKEYE) OUTER END-3 LINK INNER END
ELECTRIC (BR)
90
3.5
TUNGSTEN
32.5
NOT FITTED
NOT FITTED
DRIVER/GUARD
RETRACTABLE SPINDLE-559 X 356 OVAL OUTER END-CENTRE INNER END
DZ

ALTERNATIVES

COMMONWEALTH

FITTED

DAD, DAD 1C

TRACTION DATA FOR MULTIPLE UNITS

EMU- INTRODUCED CLASS 414/3 1957, CLASS 413/3 AS 414/3 1957 RECLASSED 1983.
VOLTAGE 750/850 VOLTS D.C. THIRD RAIL

BASIC TYPE

EE 362 0A

VARIANTS

1B COMMONWEALTH BOGIES, S.R. DESIGN REFERENCE CODE DAD, A.W.S. FITTED.
2B COMMONWEALTH BOGIES, S.R. DESIGN REFERENCE CODE DAD 1C, A.W.S. FITTED.
3A A.W.S. FITTED.

DRIVING TRAILER COMPOSITE

CLASS 422/1
422/2
421/1
421/2

DTC

EE 363

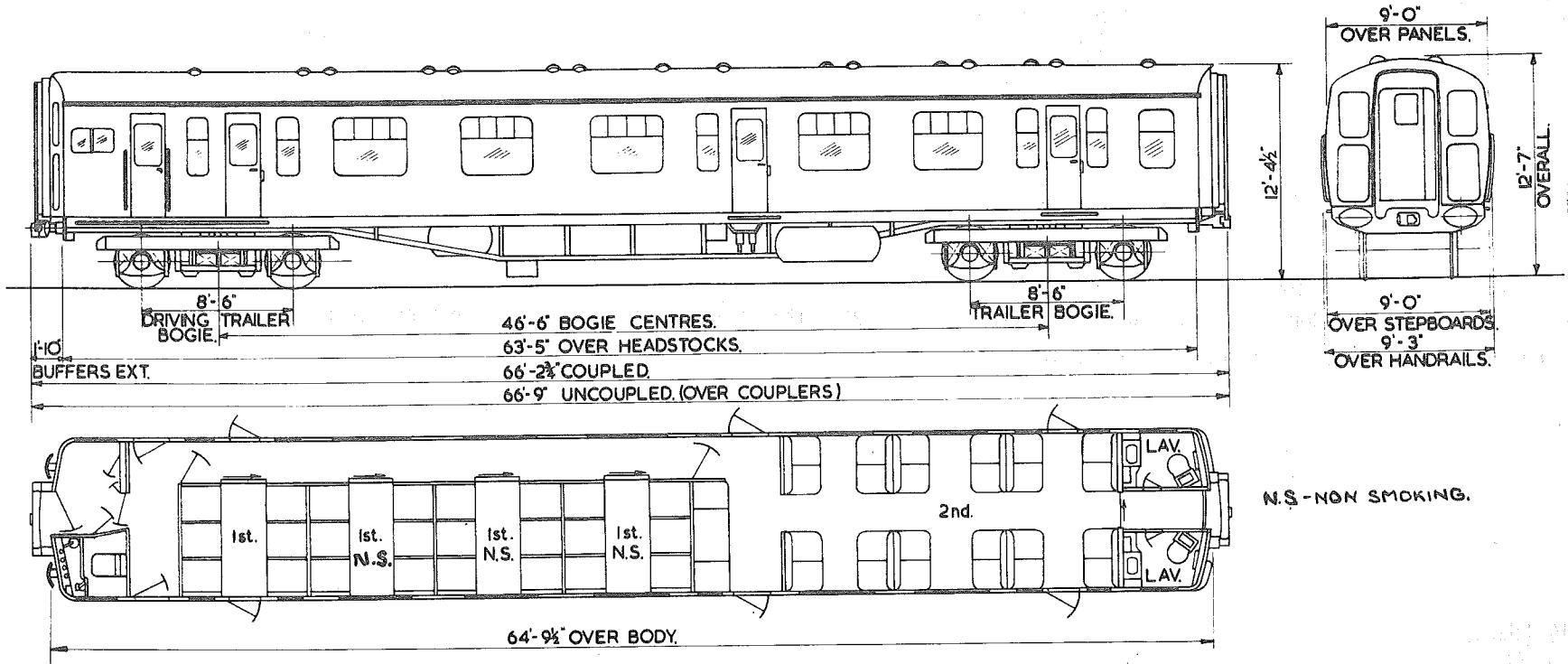

N.S. - NON SMOKING.

- | | |
|---------------------|--|
| SEATS | 24 FIRST CLASS 28 SECOND CLASS |
| TOILETS | 2 |
| COMPARTMENTS | 4 FIRST CLASS PLUS 1 SECOND CLASS SALOON |
| GUARDS COMPARTMENTS | - |
| VENTILATION | - |
| CATERING EQUIPMENT | - |

ORIGINAL DIAGRAMS FOR REFERENCE:-
BR 452

ISSUE 4 DATE NOV 84

EE 363

BASIC TYPE

ALTERNATIVES

BRAKES
BOGIE/SUSPENSION
BODY CONSTRUCTION
COUPLINGS

TRAIN HEATING
MAX.SPEED M.P.H.
MIN.RAD.CURVE CHAINS
LIGHTING
TARE WEIGHT TONNES
GANGWAYS
A.W.S.
TRAIN COMMUNICATION
BUFFERS
S.R.DESIGN REFERENCE CODE

ELECTRO PNEUMATIC
B5(S.R.)
STEEL
AUTOMATIC DROPHEAD(BUCKEYE) OUTER END-AUTOMATIC SOLID SHANK
(ALLIANCE NO.2) INNER END
ELECTRIC(BR)
90
3.5
TUNGSTEN
36
EXPRESS ELECTRIC
NOT FITTED
DRIVER/GUARD
RETRACTABLE SPINDLE-559 X 356 OVAL OUTER END ONLY
FA

FITTED

FA 1A, FA 2A

TRACTION DATA FOR MULTIPLE UNITS

EMU- INTRODUCED-CLASS 420/1 1965-CLASS 420/2 & 421/2 1970-CLASS 421/1 1964.CLASS 420 RECLASSIFIED 422 1984.
VOLTAGE 750/850 VOLTS D.C.THIRD RAIL

BASIC TYPE

EE 363 0A

VARIANTS

- 1B S.R.DESIGN REFERENCE CODE FA 1A.
- 2B S.R.DESIGN REFERENCE CODE FA 2A.
- 3B S.R.DESIGN REFERENCE CODE FA 1A, A.W.S.FITTED.
- 4B S.R.DESIGN REFERENCE CODE FA 2A, A.W.S.FITTED.
- 5A S.R.DESIGN REFERENCE CODE FA, A.W.S.FITTED.

DRIVING TRAILER COMPOSITE

CLASS 422/1
422/2
421/1
421/2

DTC

EE 364

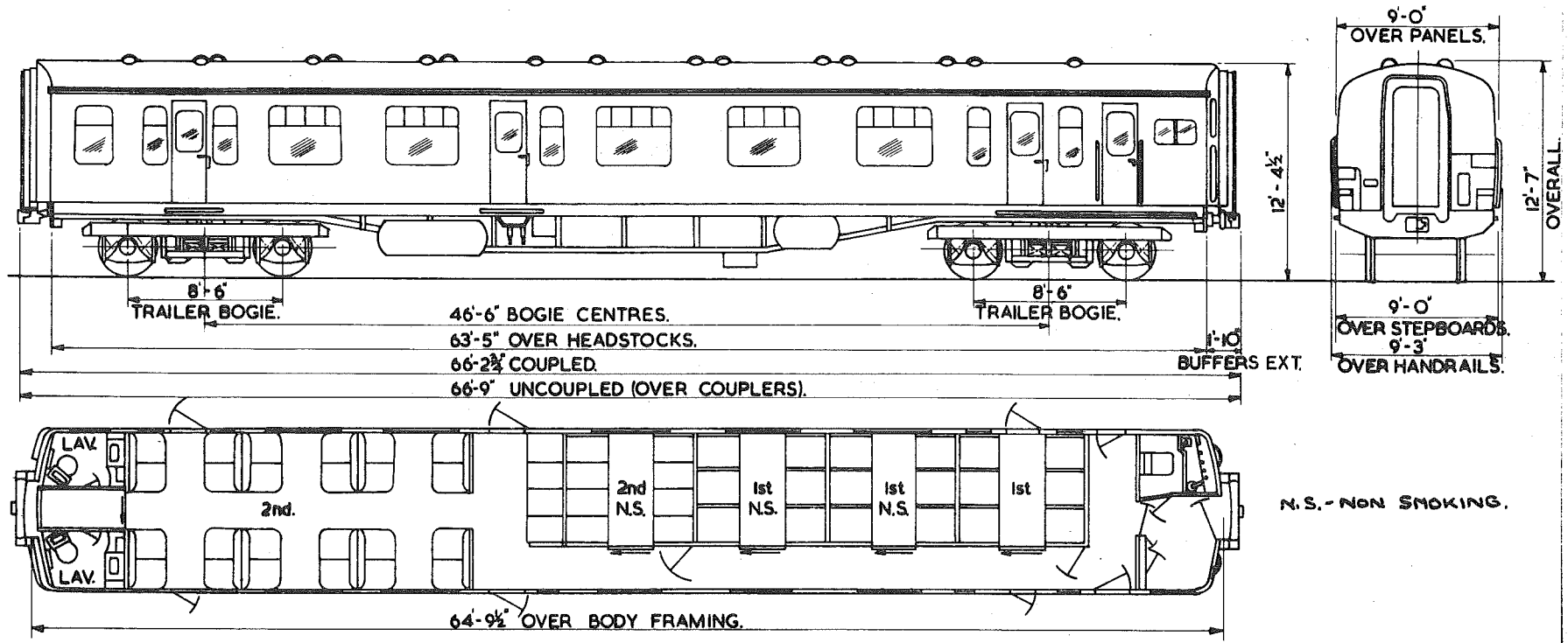

N.S. - NON SMOKING.

- | | |
|---------------------|---|
| SEATS | 18 FIRST CLASS 36 SECOND CLASS |
| TOILETS | 2 |
| COMPARTMENTS | 3 FIRST CLASS 1 SECOND CLASS PLUS 1 SECOND CLASS SALOON |
| GUARDS COMPARTMENTS | - |
| VENTILATION | - |
| CATERING EQUIPMENT | - |

ORIGINAL DIAGRAMS FOR REFERENCE:-
BR 453

ISSUE 3 DATE JAN 84

EE 364

BRAKES
BOGIE/SUSPENSION
BODY CONSTRUCTION
COUPLINGS
TRAIN HEATING
MAX. SPEED M.P.H.
MIN. RAD. CURVE CHAINS
LIGHTING
TARE WEIGHT TONNES
GANGWAYS
A.W.S.
TRAIN COMMUNICATION
BUFFERS
S.R. DESIGN REFERENCE CODE

BASIC TYPE

ELECTRO PNEUMATIC
B5(S.R.)
STEEL
AUTOMATIC DROPHEAD(BUCKEYE) OUTER END-AUTOMATIC SOLID SHANK
(ALLIANCE NO.2) INNER END
ELECTRIC(BR)
90
3.5
TUNGSTEN
35.5
EXPRESS ELECTRIC
NOT FITTED
DRIVER/GUARD
RETRACTABLE SPINDLE-559 X 356 OVAL OUTER END ONLY
FA

ALTERNATIVES

FITTED

FA 1A, FA 2A, FA 3A

TRACTION DATA FOR MULTIPLE UNITS

EMU- INTRODUCED-CLASS 420/1 1965-CLASS 420/2 & 421/2 1970-CLASS 421/1 1964-CLASS 420 RECLASSIFIED 422 1984.

VOLTAGE

BASIC TYPE

EE 364 0A

VARIANTS

1B S.R. DESIGN REFERENCE CODE FA 1A.
2B S.R. DESIGN REFERENCE CODE FA 2A.
3B S.R. DESIGN REFERENCE CODE FA 3A, A.W.S. FITTED.
4B S.R. DESIGN REFERENCE CODE FA 1A, A.W.S. FITTED.
5B S.R. DESIGN REFERENCE CODE FA 2A, A.W.S. FITTED.
6A S.R. DESIGN REFERENCE CODE FA, A.W.S. FITTED.

DRIVING TRAILER COMPOSITE

CLASS 423

DTC

EE 365

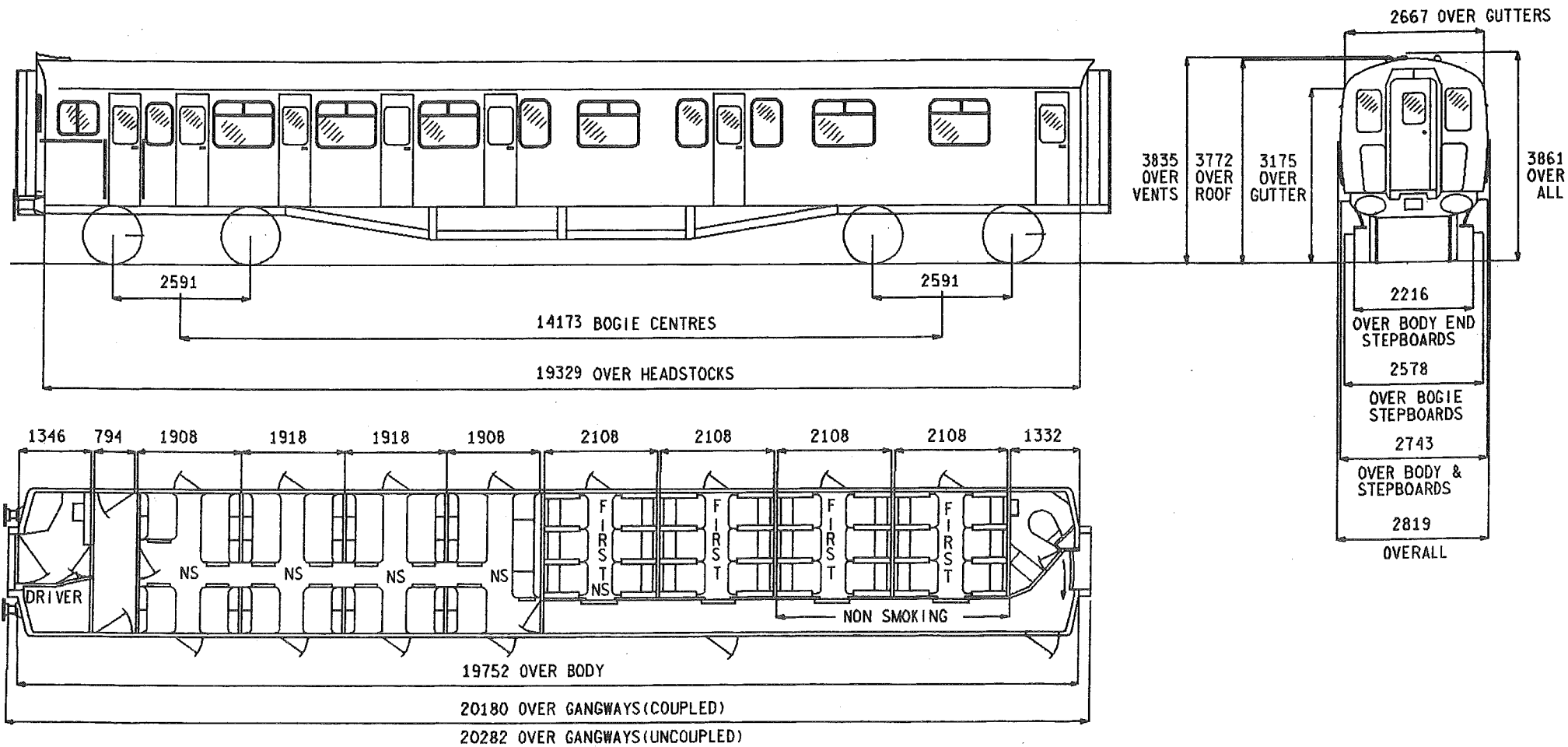

- | | |
|---------------------|--|
| SEATS | 24 FIRST CLASS 38 SECOND CLASS |
| TOILETS | 1 |
| COMPARTMENTS | 4 FIRST CLASS PLUS 1 SECOND CLASS SALOON |
| GUARDS COMPARTMENTS | - |
| VENTILATION | - |
| CATERING EQUIPMENT | - |

ORIGINAL DIAGRAMS FOR REFERENCE:-
BR 458

ISSUE 3 DATE MAR 86

EE 365

BASIC TYPE

BRAKES
BOGIE/SUSPENSION
BODY CONSTRUCTION
COUPLINGS

TRAIN HEATING
MAX.SPEED M.P.H.
MIN.RAD.CURVE CHAINS
LIGHTING
TARE WEIGHT TONNES
GANGWAYS
A.W.S.
TRAIN COMMUNICATION
BUFFERS
S.R.DESIGN REFERENCE CODE

ELECTRO PNEUMATIC
B5(S.R.)
STEEL
AUTOMATIC DROPHEAD(BUCKEYE) OUTER END-AUTOMATIC SOLID SHANK
(ALLIANCE NO.2) INNER END
ELECTRIC(BR)
90
3.5
TUNGSTEN
32.5
EXPRESS ELECTRIC
FITTED
DRIVER/GUARD
RETRACTABLE SPINDLE-559 X 356 OVAL OUTER END ONLY
FB

ALTERNATIVES

TRACTION DATA FOR MULTIPLE UNITS

EMU- INTRODUCED 1967.
VOLTAGE 750/850 VOLTS D.C. THIRD RAIL.

BASIC TYPE

EE 365 1A

VARIANTS

NONE

DRIVING TRAILER COMPOSITE

CLASS 423/1

DTC

EE 366

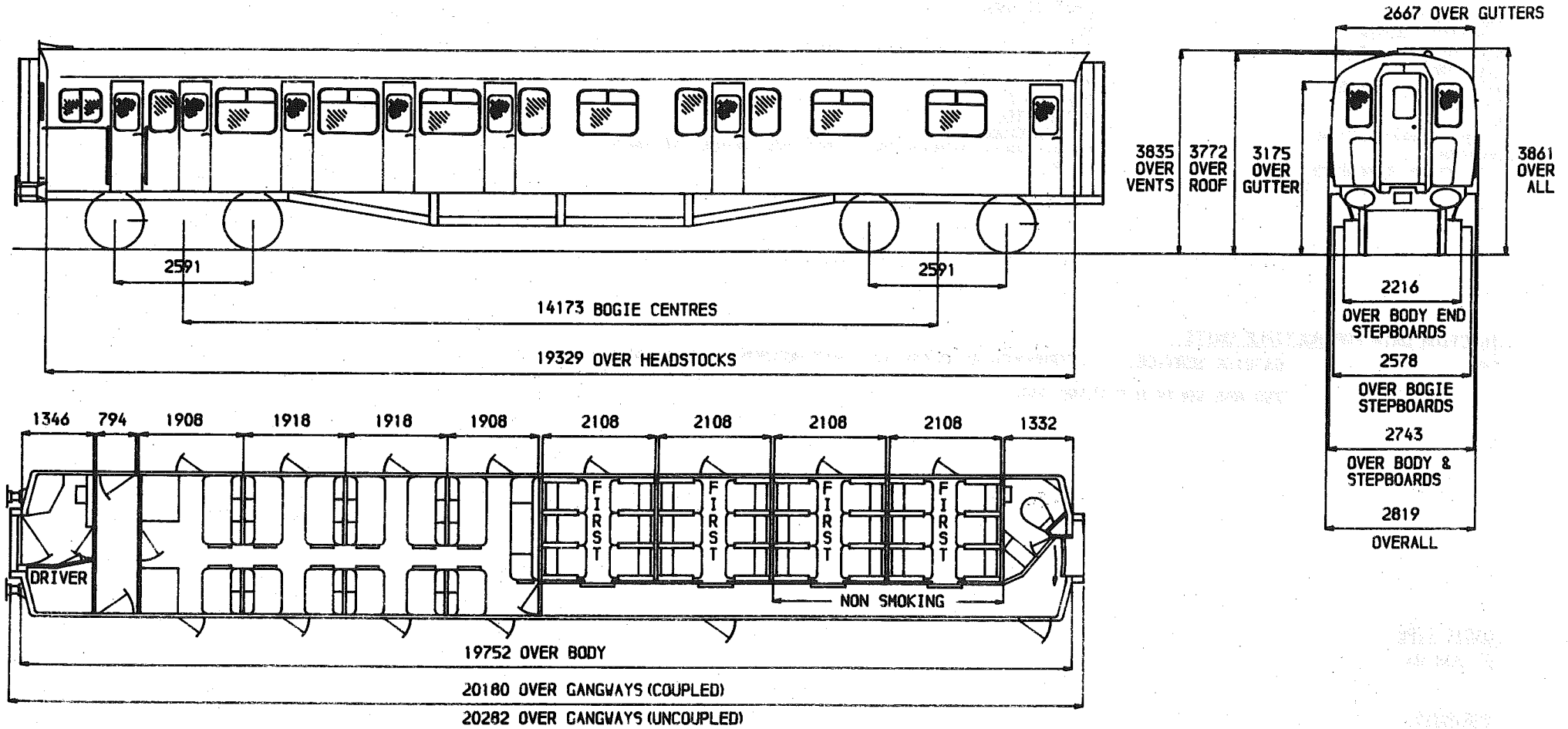

- SEATS
- TOILETS
- COMPARTMENTS
- GUARDS COMPARTMENTS
- VENTILATION
- CATERING EQUIPMENT

- 24 FIRST CLASS 34 SECOND CLASS
- 1
- 4 FIRST CLASS PLUS 1 SECOND CLASS SALOON
-
-
-

ORIGINAL DIAGRAMS FOR REFERENCE.-
BR 841

ISSUE 1 DATE SEP 80
(visit <http://www.barrowmoremrg.co.uk>)

EE 366

BASIC TYPE

ALTERNATIVES

BRAKES
BOGIE/SUSPENSION
BODY CONSTRUCTION
COUPLINGS

TRAIN HEATING
MAX. SPEED M.P.H.
MIN. RAD. CURVE CHAINS
LIGHTING
TARE WEIGHT TONNES
GANGWAYS
A.V.S.
TRAIN COMMUNICATION
BUFFERS
S.R. DESIGN REFERENCE CODE

ELECTRO PNEUMATIC
B5 (S.R.)
STEEL
AUTOMATIC DROPHEAD (BUCKEYE) OUTER END-AUTOMATIC SOLID SHANK
(ALLIANCE NO.2) INNER END
ELECTRIC (BR)
90
3.5
ELECTRIC
35
EXPRESS ELECTRIC
NOT FITTED
DRIVER/GUARD
RETRACTABLE SPINDLE-559 X 356 OVAL OUTER END ONLY
FB 3A

FITTED

TRACTION DATA FOR MULTIPLE UNITS

EMU- GATVICK SERVICE. INTRODUCED AS CLASS 423 1967-MODIFIED & RECLASSED 1978.
VOLTAGE 750/850 VOLTS D.C. THIRD RAIL

BASIC TYPE

EE 366 0A

VARIANTS

1A A.V.S. FITTED.

DRIVING TRAILER COMPOSITE

CLASS 423

DTC

EE 367

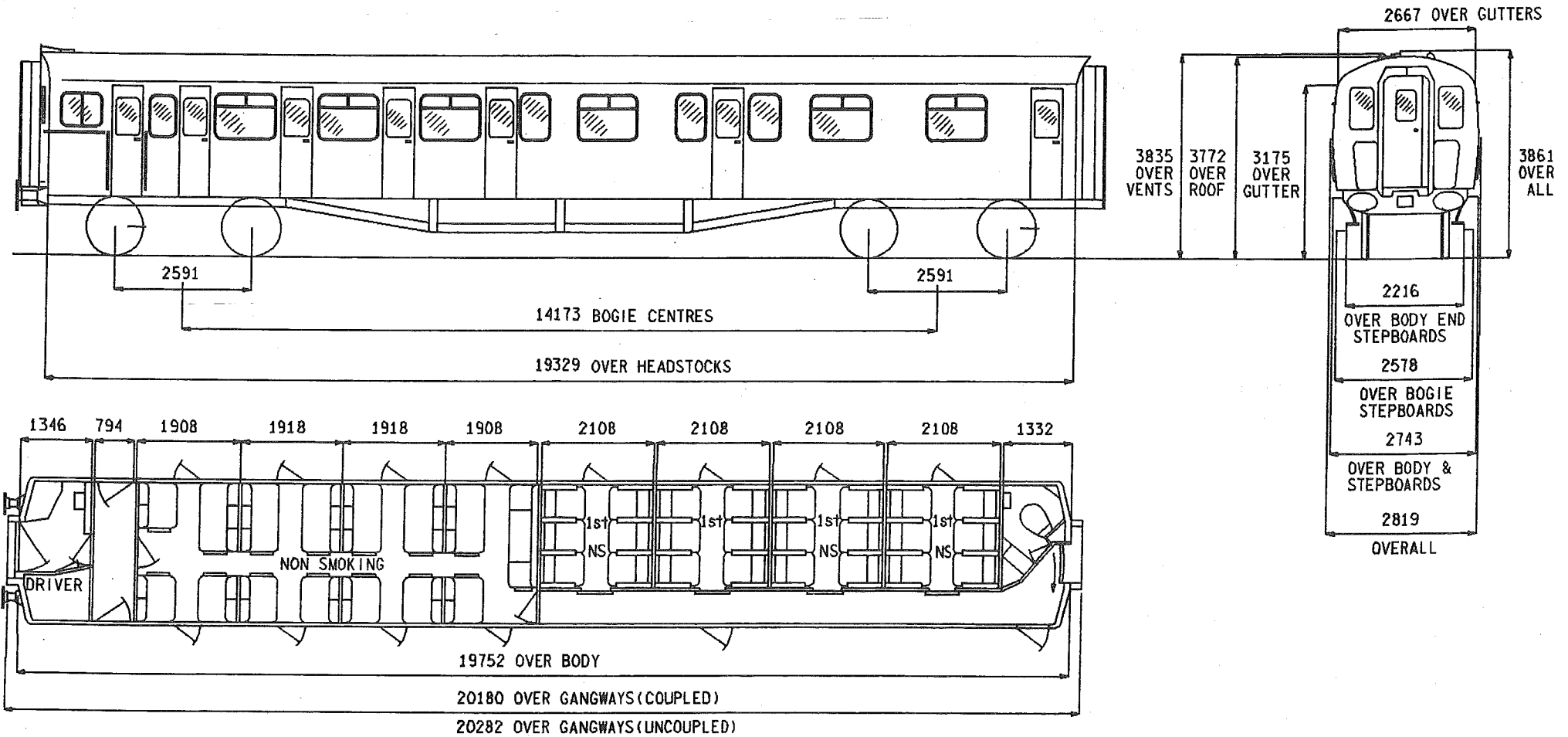

- | | |
|---------------------|---------------------------------|
| SEATS | 24 FIRST CLASS, 38 SECOND CLASS |
| TOILETS | 1 |
| COMPARTMENTS | 4 FIRST CLASS, 1 SECOND SALOON |
| GUARDS COMPARTMENTS | - |
| VENTILATION | - |
| CATERING EQUIPMENT | - |

ORIGINAL DIAGRAMS FOR REFERENCE:-
BR 459

ISSUE DATE
4 MAR 86

EE 367

BASIC TYPE

BRAKES
BOGIE/SUSPENSION
BODY CONSTRUCTION
COUPLINGS

TRAIN HEATING
MAX.SPEED M.P.H.
MIN.RAD.CURVE CHAINS
LIGHTING
TARE WEIGHT TONNES
GANGWAYS
A.W.S.
TRAIN COMMUNICATION
BUFFERS
S.R.DESIGN REFERENCE CODE

ELECTRO PNEUMATIC
B5(S.R.)
STEEL
AUTOMATIC DROPHEAD(BUCKEYE) OUTER END, AUTOMATIC SOLID SHANK
(ALLIANCE NO 2) INNER END
ELECTRIC(BR)
90
3.5
TUNGSTEN
35.5
EXPRESS ELECTRIC
NOT FITTED
DRIVER/GUARD
RETRACTABLE SPINDLE-559 X 356 OVAL-OUTER END ONLY
FB 2A

ALTERNATIVES

FITTED

FB 1A, FB 3A, FB

TRACTION DATA FOR MULTIPLE UNITS

EMU- INTRODUCED 1967
VOLTAGE 750/850 VOLTS D.C. THIRD RAIL

BASIC TYPE

EE 367 2A

VARIANTS

3A SR DESIGN REF.CODE FB 3A.
4A SR DESIGN REF CODE FB, A.W.S.FITTED.
5A SR DESIGN REF.CODE FB 1A, A.W.S.FITTED.
6A SR DESIGN REF.CODE FB 3A, A.W.S.FITTED.
7A A.W.S.FITTED.

DRIVING TRAILER COMPOSITE

CLASS 423

DTC

EE 368

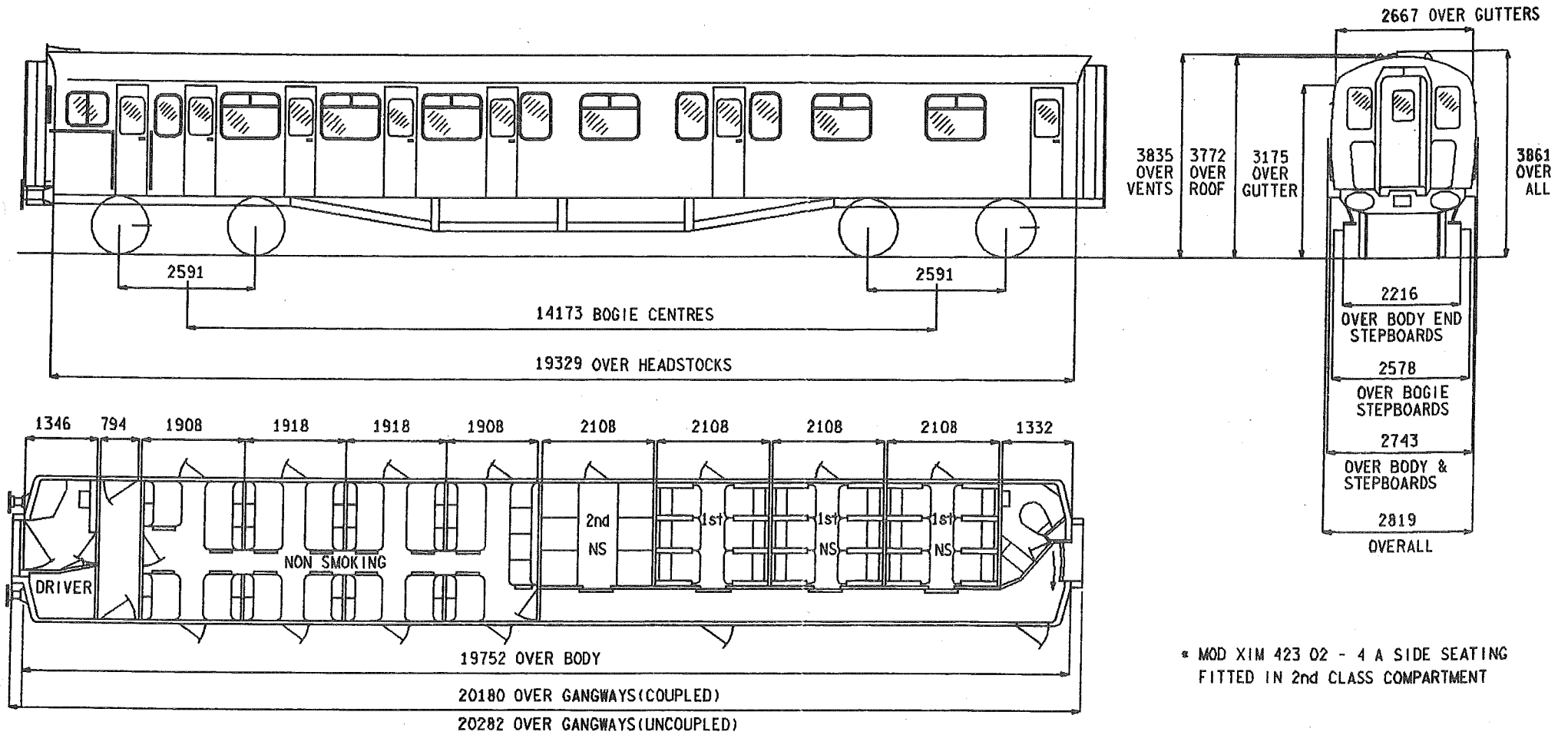

* MOD X1M 423 02 - 4 A SIDE SEATING
FITTED IN 2nd CLASS COMPARTMENT

- | | |
|---------------------|--|
| SEATS | 18 FIRST CLASS, 44 SECOND CLASS * |
| TOILETS | 1 |
| COMPARTMENTS | 4 FIRST CLASS, 1 SECOND CLASS, 1 SECOND SALOON |
| GUARDS COMPARTMENTS | - |
| VENTILATION | - |
| CATERING EQUIPMENT | - |

ORIGINAL DIAGRAMS FOR REFERENCE:-
BR 459

ISSUE 1 DATE JUN 86

EE 368

BRAKES
BOGIE/SUSPENSION
BODY CONSTRUCTION
COUPLINGS

TRAIN HEATING
MAX.SPEED M.P.H.
MIN.RAD.CURVE CHAINS
LIGHTING
TARE WEIGHT TONNES
GANGWAYS
A.W.S.
TRAIN COMMUNICATION
BUFFERS
S.R.DESIGN REFERENCE CODE

BASIC TYPE

ELECTRO PNEUMATIC
B5(S.R.)
STEEL
AUTOMATIC DROPHEAD(BUCKEYE) OUTER END, AUTOMATIC SOLID SHANK
(ALLIANCE NO 2) INNER END
ELECTRIC(BR)
90
3.5
TUNGSTEN
35.5
EXPRESS ELECTRIC
NOT FITTED
DRIVER/GUARD
RETRACTABLE SPINDLE-559 X 356 OVAL-OUTER END ONLY
FB 2A

ALTERNATIVES

FITTED

FB 3A,FB

TRACTION DATA FOR MULTIPLE UNITS

EMU- INTRODUCED 1967

VOLTAGE 750/850 VOLTS D.C.THIRD RAIL

BASIC TYPE

EE 368 OA

VARIANTS

- 1A SR DESIGN REF CODE FB, A.W.S.FITTED.
- 2A SR DESIGN REF.CODE FB 3A, A.W.S.FITTED.
- 3A A.W.S.FITTED.
- 0B 46 2nd CLASS SEATS.
- 1B SR DESIGN REF CODE FB, A.W.S.FITTED, 46 2nd CLASS SEATS.
- 2B SR DESIGN REF.CODE FB 3A, A.W.S.FITTED, 46 2nd CLASS SEATS.
- 3B A.W.S.FITTED, 46 2nd CLASS SEATS.

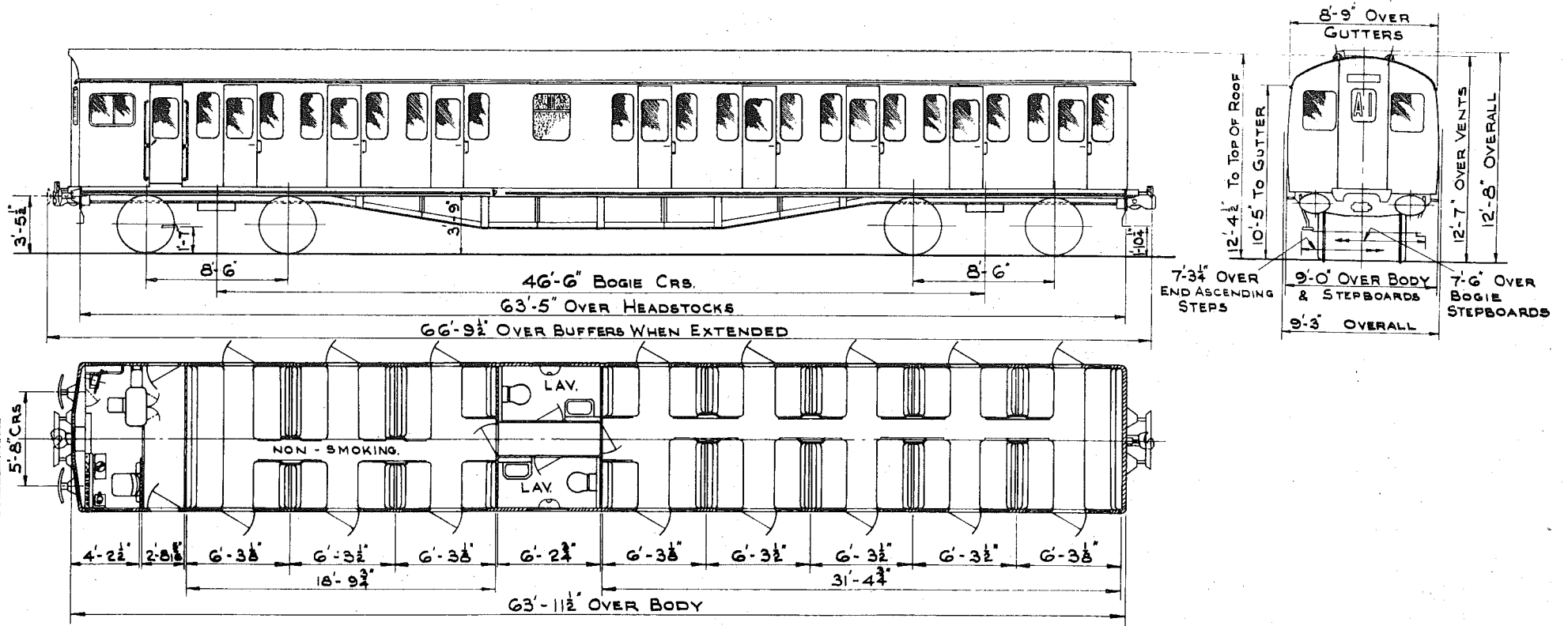

SEATS	80
TOILETS	2
COMPARTMENTS	-
GUARDS COMPARTMENTS	-
VENTILATION	-
CATERING EQUIPMENT	-

ORIGINAL DIAGRAMS FOR REFERENCE:-
BR 432

ISSUE 3 DATE MAR 87

EF 201

BASIC TYPE

ALTERNATIVES

BRAKES
BOGIE/SUSPENSION
BODY CONSTRUCTION
COUPLINGS

TRAIN HEATING
MAX.SPEED M.P.H.
MIN.RAD.CURVE CHAINS
LIGHTING
TARE WEIGHT TONNES
GANGWAYS
A.W.S.
TRAIN COMMUNICATION
BUFFERS

ELECTRO PNEUMATIC
GRESLEY ET2
STEEL
AUTOMATIC DROPHEAD(BUCKEYE) OUTER END, AUTOMATIC SOLID SHANK
(ALLIANCE NO 2) INNER END
ELECTRIC(BR)
75
3.5
TUNGSTEN
36.5
NOT FITTED
NOT FITTED
NOT FITTED
RETRACTABLE SPINDLE-559 X 356 OVAL - OUTER END ONLY

B5

TRACTION DATA FOR MULTIPLE UNITS

EMU- FENCHURCH ST.-SHOEBURYNESS INTRODUCED 1958.
VOLTAGE 25 & 6.25 KV A.C.OVRHEAD.

BASIC TYPE

EF 201 OA

VARIANTS

OB B5 BOGIES.

BATTERY DRIVING TRAILER SECOND

CLASS 303

BDS

EF 202

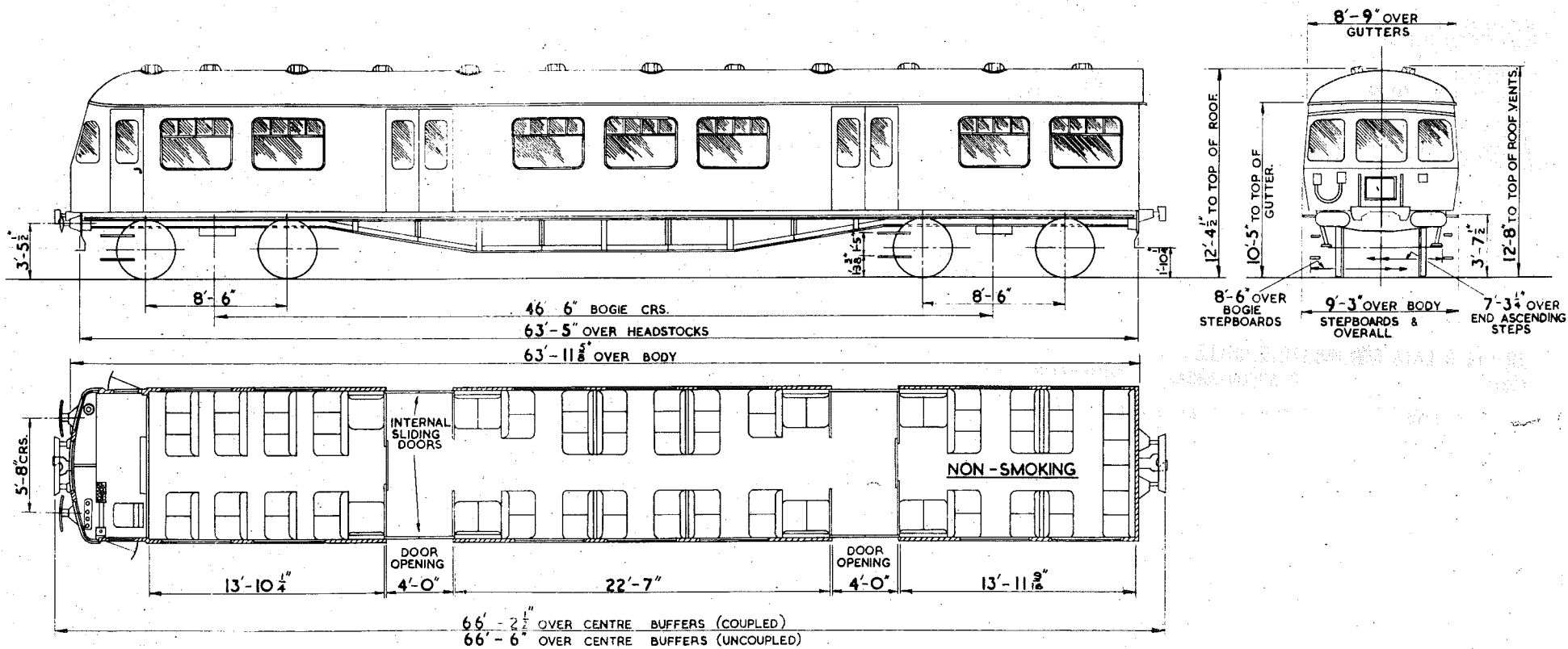

SEATS	83
TOILETS	-
COMPARTMENTS	-
GUARDS COMPARTMENTS	-
VENTILATION	-
CATERING EQUIPMENT	-

ORIGINAL DIAGRAMS FOR REFERENCE,-
BR 439

ISSUE 1 DATE SEP' 80

EF 202

ALTERNATIVES

BASIC TYPE

BRAKES
BOGIE/SUSPENSION
BODY CONSTRUCTION
COUPLINGS

ELECTRO PNEUMATIC
GRESLEY ET3 *Drawn SC ES 875A*
STEEL
AUTOMATIC DROPHEAD (BUCKEYE) OUTER END-AUTOMATIC SOLID SHANK
(ALLIANCE NO.2) INNER END

TRAIN HEATING
MAX. SPEED M.P.H.
MIN. RAD. CURVE CHAINS
LIGHTING
TARE WEIGHT TONNES
GANGWAYS
A.W.S.
TRAIN COMMUNICATION
BUFFERS

ELECTRIC (BR)
75
3.5
ELECTRIC
38
NOT FITTED
FITTED
NOT FITTED
RETRACTABLE SPINDLE-559 X 356 OVAL OUTER END ONLY

TRACTION DATA FOR MULTIPLE UNITS

EMU- GLASGOW AREA. INTRODUCED 1960.
VOLTAGE 25 & 6.25 KV A.C. OVERHEAD

BASIC TYPE

EF 202 0A

VARIANTS

NONE

BATTERY DRIVING TRAILER SECOND

CLASS 304/1

BDS

EF 203

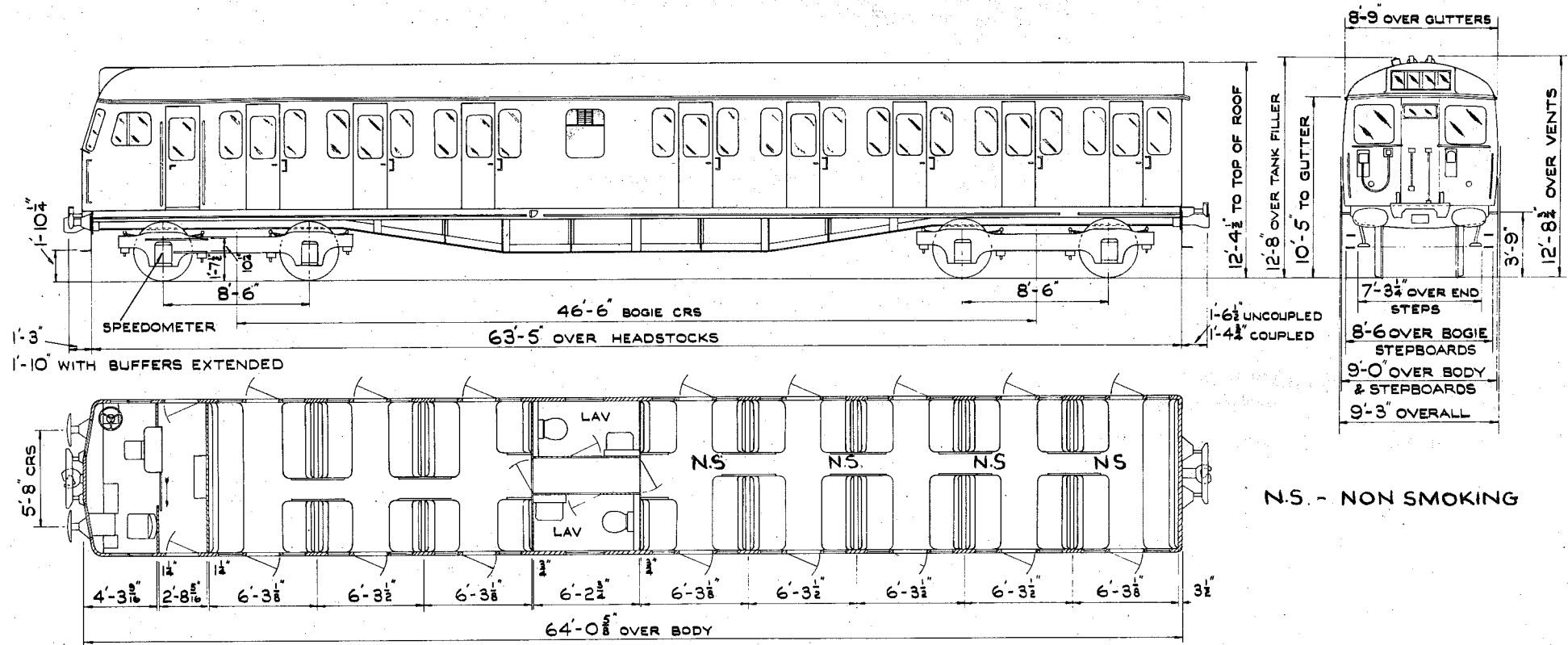

N.S. - NON SMOKING

SEATS	80
TOILETS	2
COMPARTMENTS	-
GUARDS COMPARTMENTS	-
VENTILATION	-
CATERING EQUIPMENT	-

ORIGINAL DIAGRAMS FOR REFERENCE.-
BR 434

ISSUE 1 DATE SEP '80

EF 203

BASIC TYPE

BRAKES
BOGIE/SUSPENSION
BODY CONSTRUCTION
COUPLINGS

TRAIN HEATING
MAX. SPEED M.P.H.
MIN. RAD. CURVE CHAINS
LIGHTING
TARE WEIGHT TONNES
GANGWAYS
A.V.S.
TRAIN COMMUNICATION
BUFFERS

ELECTRO PNEUMATIC
GRESLEY ET8
STEEL
AUTOMATIC DROPHEAD (BUCKEYE) OUTER END-AUTOMATIC SOLID SHANK
(ALLIANCE NO.2) INNER END
ELECTRIC (BR)
75
3.5
ELECTRIC
36
NOT FITTED
FITTED
NOT FITTED
RETRACTABLE SPINDLE-559 X 356 OVAL OUTER END ONLY

ALTERNATIVES

TRACTION DATA FOR MULTIPLE UNITS

EMU- EUSTON-BIRMINGHAM-MANCHESTER & LIVERPOOL. INTRODUCED 1960.
VOLTAGE 25 KV A.C. OVERHEAD

BASIC TYPE

EF 203 0A

VARIANTS

NONE

BATTERY DRIVING TRAILER SECOND

CLASS 304/2
304/3

BDTS

EF 204

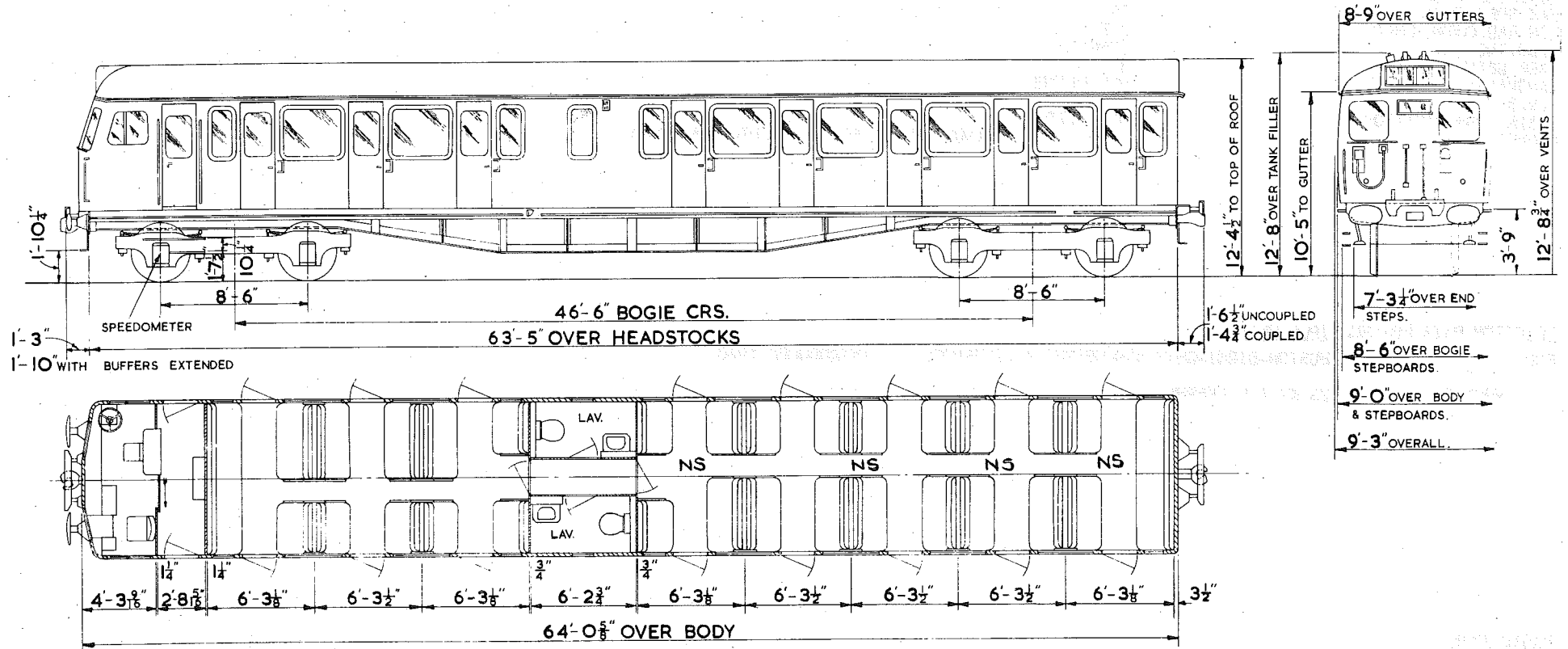

SEATS	80
TOILETS	2
COMPARTMENTS	-
GUARDS COMPARTMENTS	-
VENTILATION	-
CATERING EQUIPMENT	-

ORIGINAL DIAGRAMS FOR REFERENCE.-
BR 435

ISSUE 2 DATE MAY '81

EF 204

BASIC TYPE

ALTERNATIVES

BRAKES
BOGIE/SUSPENSION
BODY CONSTRUCTION
COUPLINGS

ELECTRO PNEUMATIC
GRESLEY ET8
STEEL
AUTOMATIC DROPHEAD (BUCKEYE) OUTER END-AUTOMATIC SOLID SHANK
(ALLIANCE NO.2) INNER END
ELECTRIC (BR)
75
3.5
TUNGSTEN
37
NOT FITTED
FITTED
NOT FITTED
RETRACTABLE SPINDLE-559 X 356 OVAL OUTER END ONLY

TRAIN HEATING
MAX. SPEED M.P.H.
MIN. RAD. CURVE CHAINS
LIGHTING
TARE WEIGHT TONNES
GANGWAYS
A. V. S.
TRAIN COMMUNICATION
BUFFERS

TRACTION DATA FOR MULTIPLE UNITS

EMU- EUSTON-BIRMINGHAM-MANCHESTER & LIVERPOOL. INTRODUCED 1960.
VOLTAGE 25 KV A.C. OVERHEAD

BASIC TYPE

EF 204 0A

VARIANTS

NONE

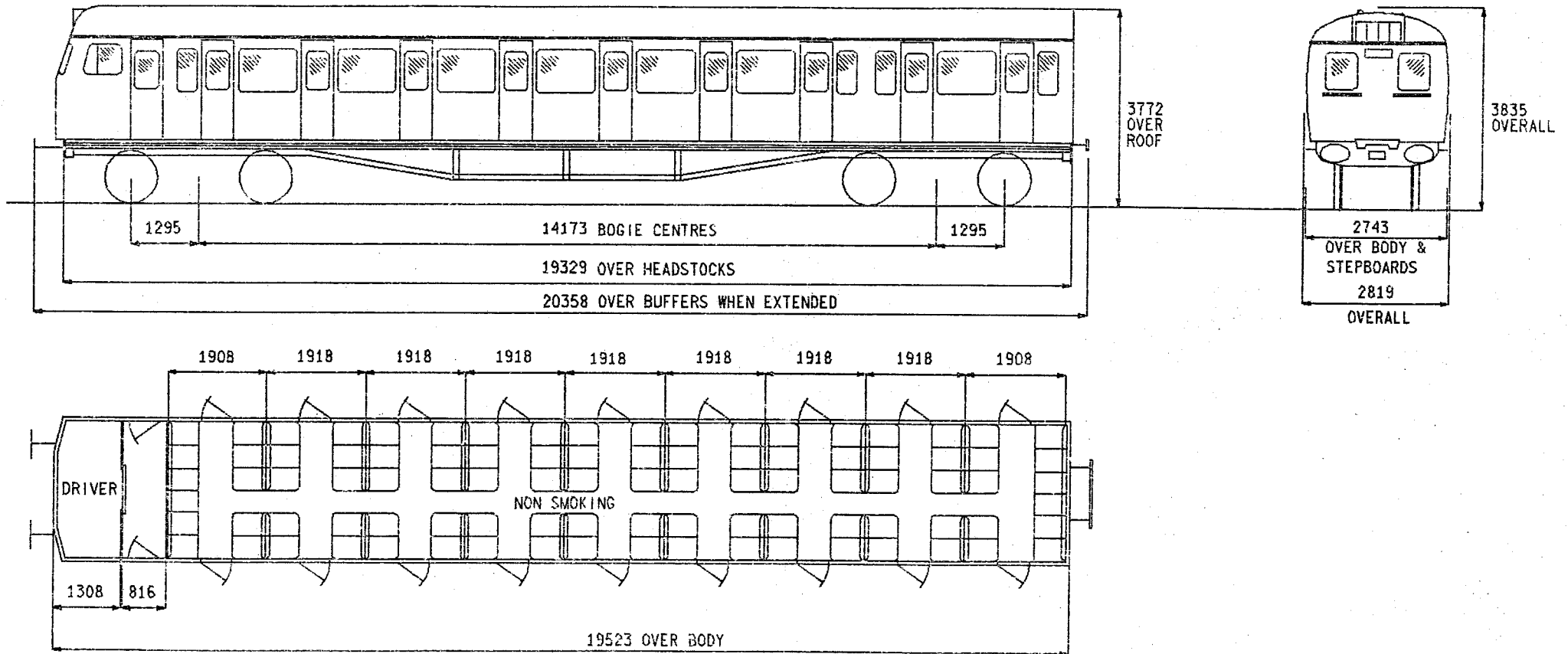

SEATS	92
TOILETS	-
COMPARTMENTS	-
GUARDS COMPARTMENTS	-
VENTILATION	-
CATERING EQUIPMENT	-

ORIGINAL DIAGRAMS FOR REFERENCE:-
BR 436

ISSUE 5 DATE MAR 87

EF 205

BRAKES
BOGIE/SUSPENSION
BODY CONSTRUCTION
COUPLINGS

TRAIN HEATING
MAX.SPEED M.P.H.
MIN.RAD.CURVE CHAINS
LIGHTING
TARE WEIGHT TONNES
GANGWAYS
A.W.S.
TRAIN COMMUNICATION
BUFFERS

BASIC TYPE

ELECTRO PNEUMATIC
GRESLEY ET8
STEEL
AUTOMATIC DROPHEAD(BUCKEYE) OUTER END-AUTOMATIC SOLID SHANK
(ALLIANCE NO.2) INNER END
ELECTRIC(BR)
75
3.5
FLUORESCENT & TUNGSTEN
35
NOT FITTED
FITTED
NOT FITTED
RETRACTABLE SPINDLE-559 X 356 OVAL OUTER END ONLY

ALTERNATIVES

GRESLEY ET8

PUBLIC ADDRESS

TRACTION DATA FOR MULTIPLE UNITS

EMU- LIVERPOOL ST.-ENFIELD & CHINGFORD. INTRODUCED-CLASS 305/1 1959- CLASS 308/3 1961.
VOLTAGE 25 & 6.25 KV A.C.OVERHEAD

BASIC TYPE

EF 205 OA

VARIANTS

0B GRESLEY ET8 BOGIES.
1C REFURBISHED,PUBLIC ADDRESS.
1D REFURBISHED,PUBLIC ADDRESS,GRESLEY ET8 BOGIES.

BATTERY DRIVING TRAILER SECOND

CLASS 305/2

BDS

EF 206

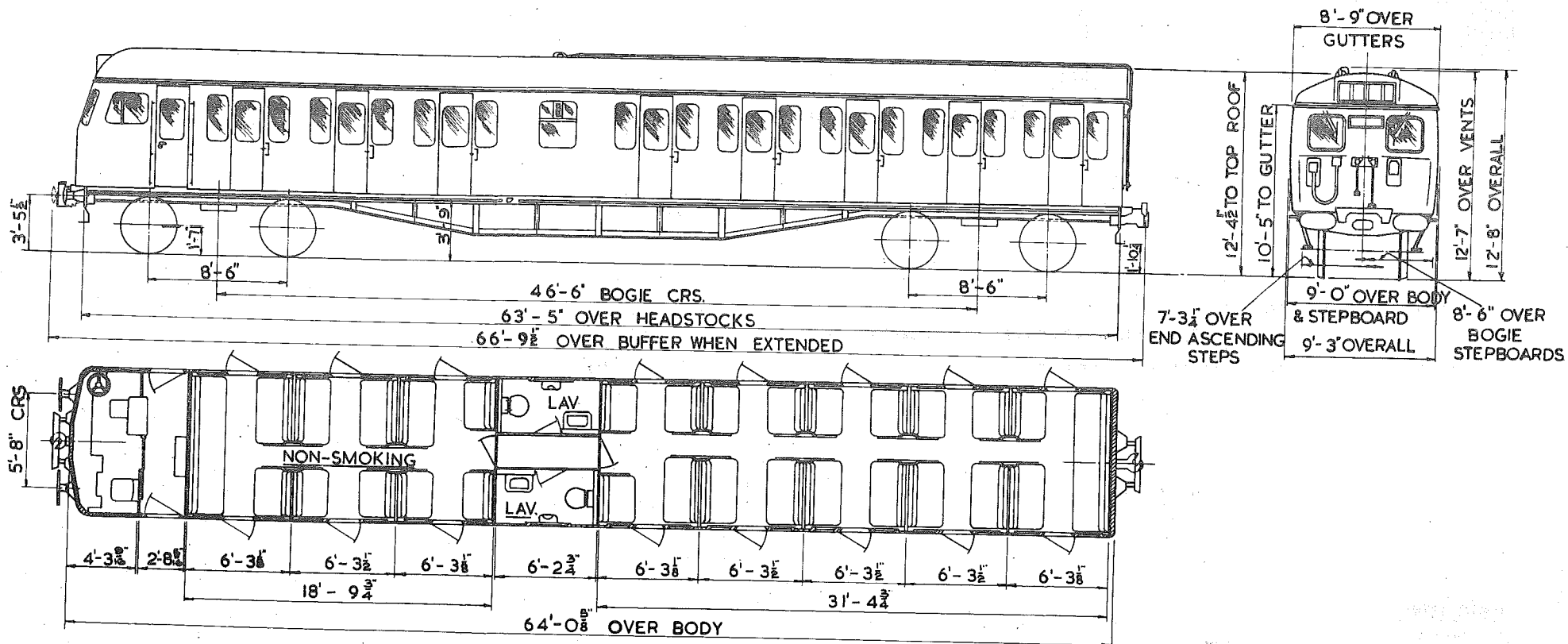

SEATS	80
TOILETS	2
COMPARTMENTS	-
GUARDS COMPARTMENTS	-
VENTILATION	-
CATERING EQUIPMENT	-

ORIGINAL DIAGRAMS FOR REFERENCE.-
BR 438

ISSUE 1 DATE SEP '80

EF 206

BASIC TYPE

ALTERNATIVES

BRAKES
BOGIE/SUSPENSION
BODY CONSTRUCTION
COUPLINGS

ELECTRO PNEUMATIC
GRESLEY ETS
STEEL
AUTOMATIC DROPHEAD (BUCKEYE) OUTER END-AUTOMATIC SOLID SHANK
(ALLIANCE NO.2) INNER END

TRAIN HEATING
MAX. SPEED M.P.H.
MIN. RAD. CURVE CHAINS
LIGHTING
TARE WEIGHT TONNES
GANGWAYS
A.V.S.
TRAIN COMMUNICATION
BUFFERS

ELECTRIC (BR)
75
3.5
ELECTRIC
36.5
NOT FITTED
FITTED
NOT FITTED
RETRACTABLE SPINDLE-559 X 356 OVAL OUTER END ONLY

TRACTION DATA FOR MULTIPLE UNITS

EMU- GREAT EASTERN OUTER SUBURBAN. INTRODUCED 1960.
VOLTAGE 25 & 6.25 KV A.C.OVERHEAD

BASIC TYPE

EF 206 0A

VARIANTS

NONE

BATTERY DRIVING TRAILER STANDARD

CLASS 308/2

BPTS

EF 208

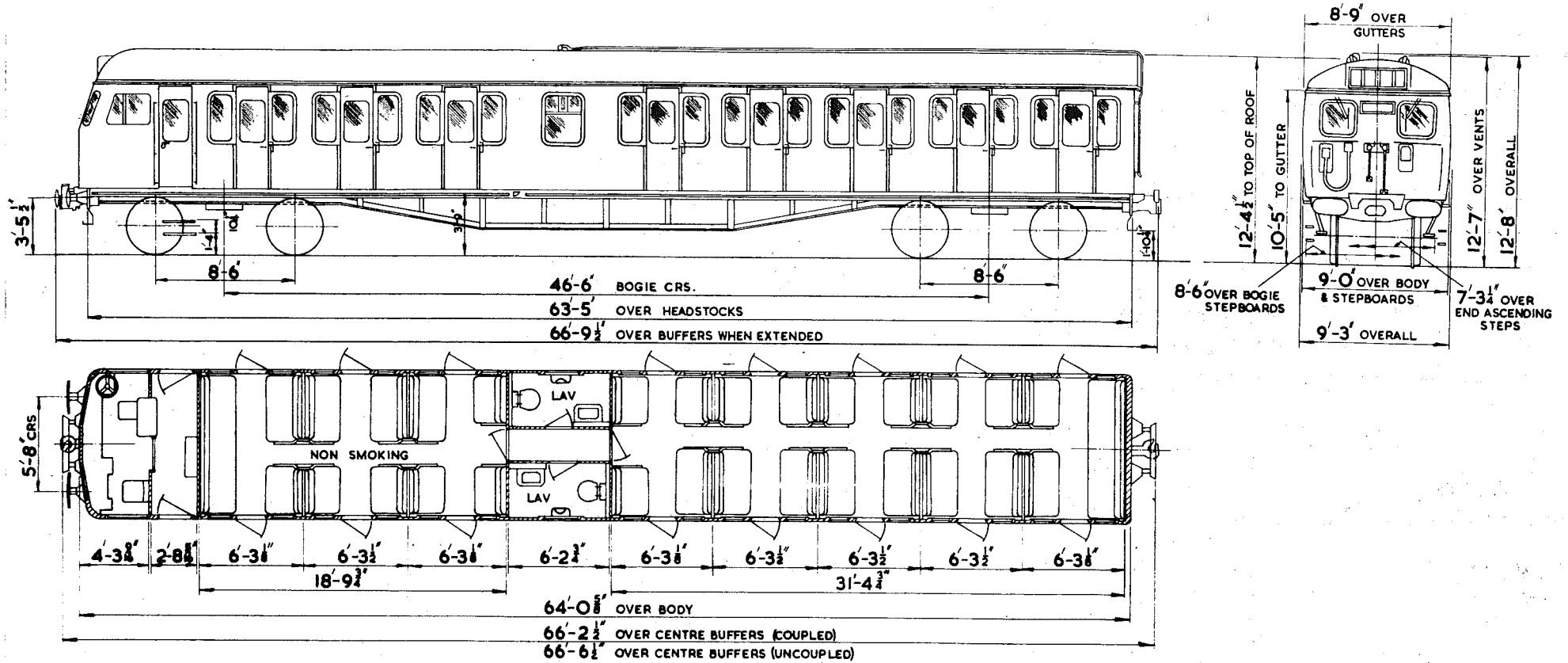

SEATS	80
TOILETS	2
COMPARTMENTS	-
GUARDS COMPARTMENTS	-
VENTILATION	-
CATERING EQUIPMENT	-

ORIGINAL DIAGRAMS FOR REFERENCE:-
BR 444

ISSUE 2 DATE AUG 87

EF 208

BASIC TYPE

ALTERNATIVES

BRAKES
BOGIE/SUSPENSION
BODY CONSTRUCTION
COUPLINGS

ELECTRO PNEUMATIC
GRESLEY ET8
STEEL
AUTOMATIC DROPHEAD(BUCKEYE) OUTER END-AUTOMATIC SOLID SHANK
(ALLIANCE NO.2) INNER END
ELECTRIC(BR)
75
3.5
TUNGSTEN
36.5
NOT FITTED
FITTED
NOT FITTED
RETRACTABLE SPINDLE-559 X 356 OVAL OUTER END ONLY

TRAIN HEATING
MAX.SPEED M.P.H.
MIN.RAD.CURVE CHAINS
LIGHTING
TARE WEIGHT TONNES
GANGWAYS
A.W.S.
TRAIN COMMUNICATION
BUFFERS

TRACTION DATA FOR MULTIPLE UNITS

EMU- CLASS 308/1 GREAT EASTERN OUTER SUBURBAN-CLASS 308/2 & 308/4 FENCHURCH ST.-SHOEBURYNNESS.
INTRODUCED-CLASS 308/1 & 308/2 1961-CLASS 308/4 AS CLASS 308/2 1961 & RECLASSED 1971.
VOLTAGE 25 & 6.25 KV A.C.OVERHEAD

BASIC TYPE

EF 208 DA

VARIANTS

NONE

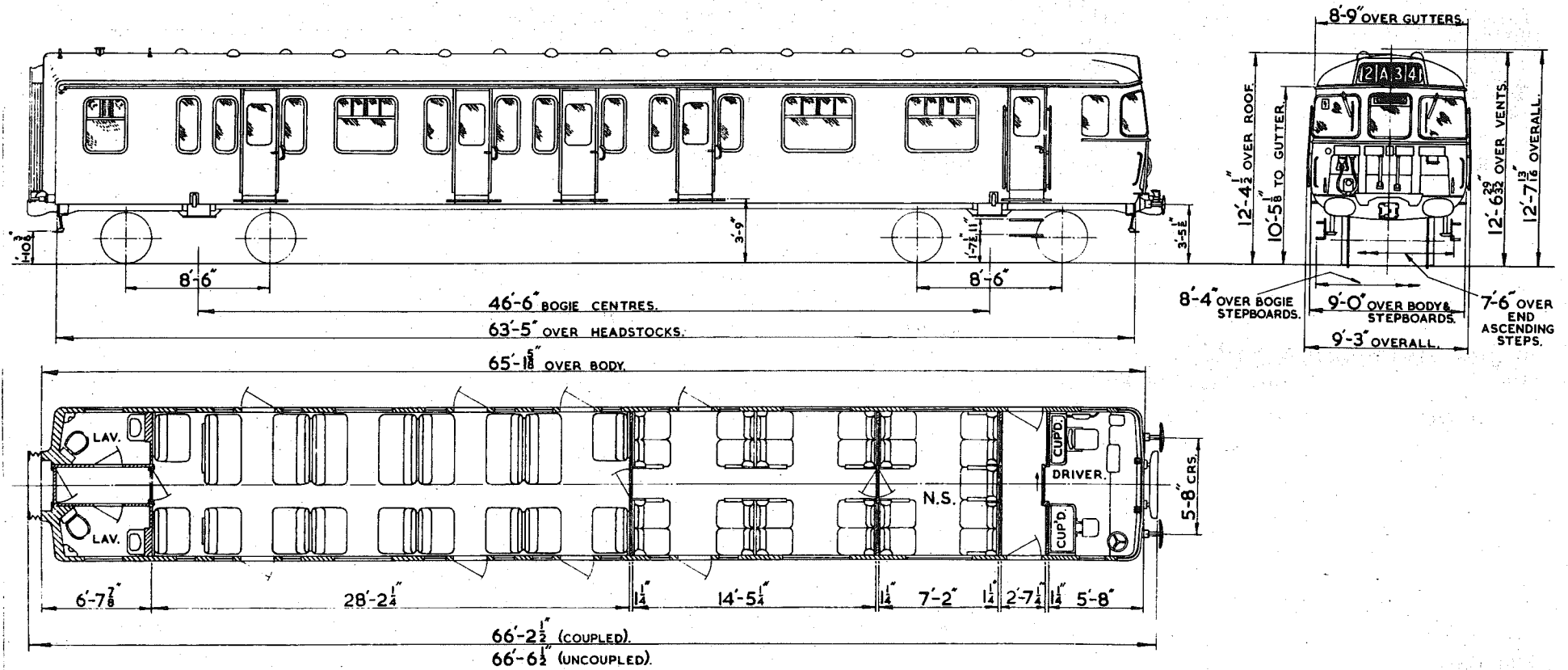

SEATS	68
TOILETS	2
COMPARTMENTS	-
GUARDS COMPARTMENTS	-
VENTILATION	-
CATERING EQUIPMENT	-

ORIGINAL DIAGRAMS FOR REFERENCE:-
BR 454

ISSUE 2 DATE DEC 85

EF 210

BRAKES
BOGIE/SUSPENSION
BODY CONSTRUCTION
COUPLINGS

TRAIN HEATING
MAX. SPEED M.P.H.
MIN. RAD. CURVE CHAINS
LIGHTING
TARE WEIGHT TONNES
GANGWAYS
A.W.S.
TRAIN COMMUNICATION
BUFFERS

BASIC TYPE

ELECTRO PNEUMATIC
B4/AM10 DT
STEEL
AUTOMATIC DROPHEAD(BUCKEYE) OUTER END, AUTOMATIC SOLID SHANK
(BUCKEYE) INNER END
ELECTRIC(BR)
75
3.5
TUNGSTEN
34.5
EXPRESS ELECTRIC INNER END ONLY
FITTED
NOT FITTED
RETRACTABLE SPINDLE-559 X 356-OUTER END ONLY

ALTERNATIVES

PUBLIC ADDRESS

TRACTION DATA FOR MULTIPLE UNITS

EMU- EUSTON-BIRMINGHAM-MANCHESTER & LIVERPOOL INTRODUCED 1966 AS DTC, MODIFIED TO BDTS 1971.
VOLTAGE 25 KV A.C. OVERHEAD.

BASIC TYPE

EF 210 0A

VARIANTS

1B FACELIFTED, PUBLIC ADDRESS FITTED

BATTERY DRIVING TRAILER STANDARD

CLASS 310/0
CLASS 310/1

BDTS

EF 211

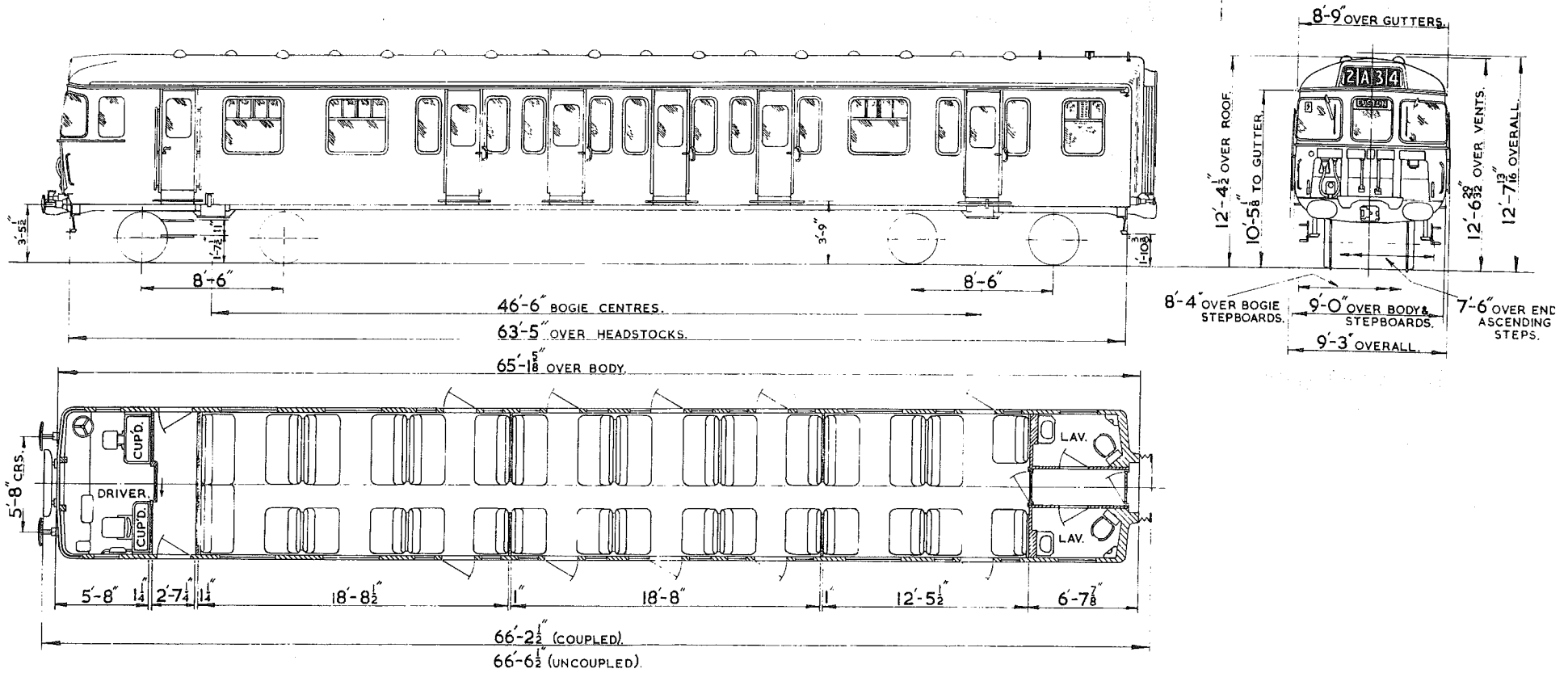

SEATS	80
TOILETS	2
COMPARTMENTS	-
GUARDS COMPARTMENTS	-
VENTILATION	-
CATERING EQUIPMENT	-

ORIGINAL DIAGRAMS FOR REFERENCE:-
BR 428

ISSUE 3 DATE AUG 88

EF 211

BRAKES
BOGIE/SUSPENSION
BODY CONSTRUCTION
COUPLINGS

TRAIN HEATING
MAX. SPEED M.P.H.
MIN. RAD. CURVE CHAINS
LIGHTING
TARE WEIGHT TONNES
GANGWAYS
A.W.S.
TRAIN COMMUNICATION
BUFFERS

BASIC TYPE

ELECTRO PNEUMATIC
B4/AM10 DT
STEEL
AUTOMATIC DROPHEAD (BUCKEYE) OUTER END-AUTOMATIC SOLID SHANK
(BUCKEYE) INNER END
ELECTRIC (BR)
75
3.5
TUNGSTEN
37.5
EXPRESS ELECTRIC INNER END ONLY
FITTED
NOT FITTED
RETRACTABLE SPINDLE-559 X 356 OVAL OUTER END ONLY

ALTERNATIVES

PUBLIC ADDRESS

TRACTION DATA FOR MULTIPLE UNITS

EMU- EUSTON-BIRMINGHAM-MANCHESTER & LIVERPOOL. INTRODUCED 1966.
VOLTAGE 25 KV A.C. OVERHEAD

BASIC TYPE

EF 211 OA

VARIANTS

1B FACELIFTED, PUBLIC ADDRESS FITTED.
2C REFURBISHED, RECLASSIFIED CLASS 310/1, PUBLIC ADDRESS FITTED.

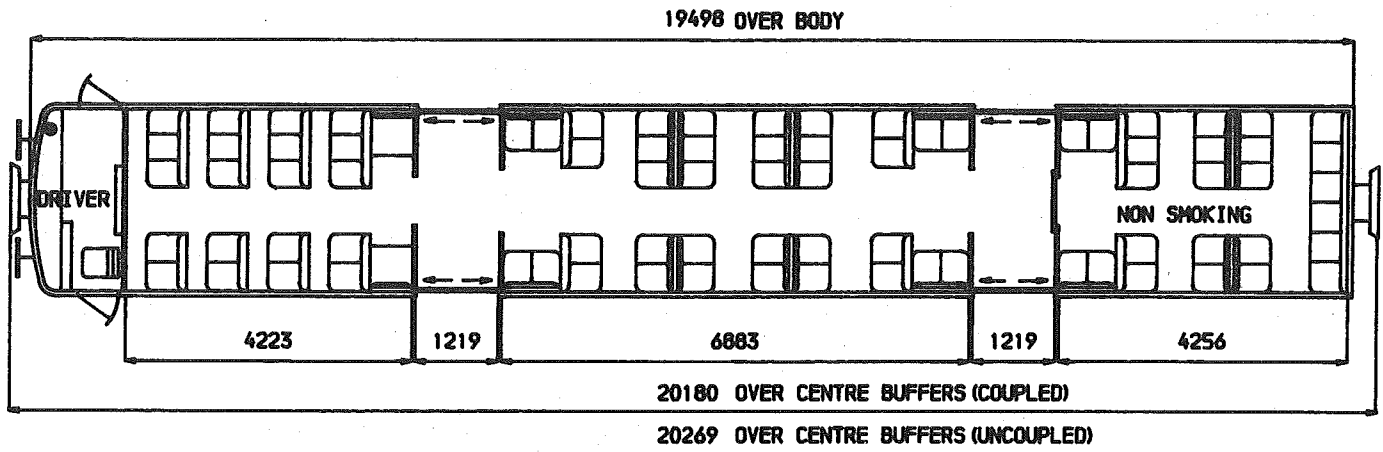
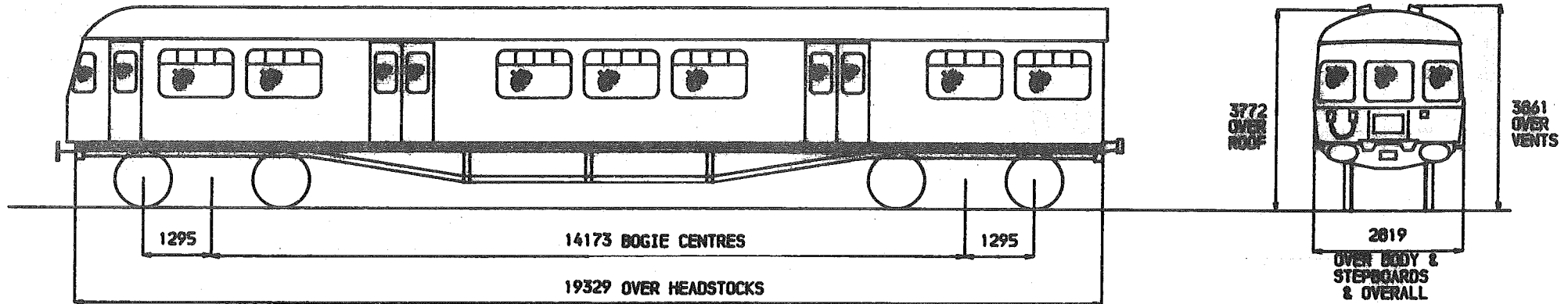

SEATS	83
TOILETS	-
COMPARTMENTS	-
GUARDS COMPARTMENTS	-
VENTILATION	-
CATERING EQUIPMENT	-

ORIGINAL DIAGRAMS FOR REFERENCE.-
 BR 375

ISSUE 1 DATE SEP' 80

EF 212

BRAKES
BOGIE/SUSPENSION
BODY CONSTRUCTION
COUPLINGS

TRAIN HEATING
MAX. SPEED M.P.H.
MIN. RAD. CURVE CHAINS
LIGHTING
TARE WEIGHT TONNES
GANGWAYS
A. V. S.
TRAIN COMMUNICATION
BUFFERS

BASIC TYPE

ELECTRO PNEUMATIC
GRESLEY ET11
STEEL
AUTOMATIC DROPHEAD (BUCKEYE) OUTER END-AUTOMATIC SOLID SHANK
(ALLIANCE NO.2) INNER END
ELECTRIC (BR)
75
3.5
ELECTRIC
37.5
NOT FITTED
FITTED
NOT FITTED
RETRACTABLE SPINDLE-559 X 356 OVAL OUTER END ONLY

ALTERNATIVES

TRACTION DATA FOR MULTIPLE UNITS

EMU- GLASGOW AREA. INTRODUCED 1967.
VOLTAGE 25 & 6.25 KV A.C. OVERHEAD

BASIC TYPE

EF 212 0A

VARIANTS

NONE

BATTERY DRIVING TRAILER SECOND

CLASS 312/0
312/1
312/2

BDTS

EF 213

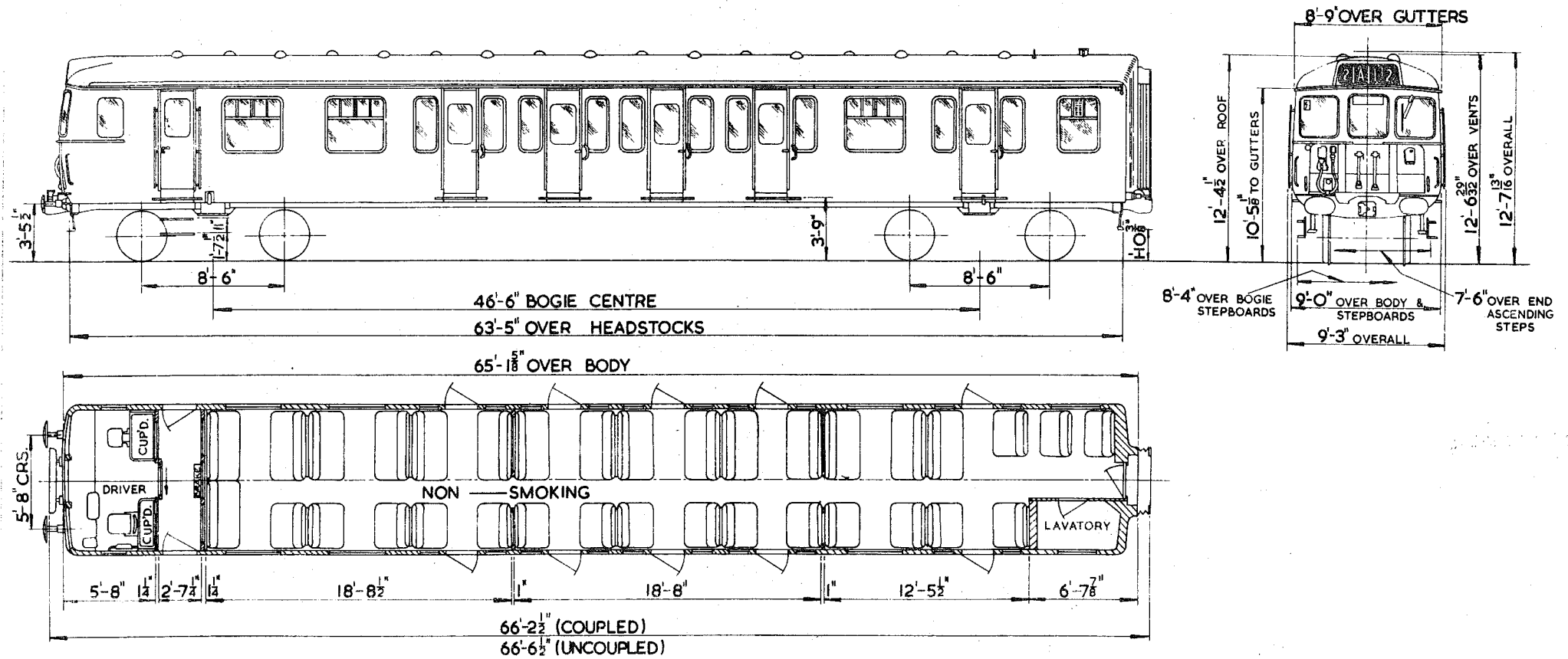

SEATS	84
TOILETS	1
COMPARTMENTS	-
GUARDS COMPARTMENTS	-
VENTILATION	-
CATERING EQUIPMENT	-

ORIGINAL DIAGRAMS FOR REFERENCE:-
BR 465

ISSUE 3 DATE MAR 87

EF 213

	<u>BASIC TYPE</u>	<u>ALTERNATIVES</u>
BRAKES	ELECTRO PNEUMATIC	
BOGIE/SUSPENSION	BT8 & BT8a (ONE OF EACH)	
BODY CONSTRUCTION	STEEL	
COUPLINGS	AUTOMATIC DROPHEAD(BUCKEYE) OUTER END-AUTOMATIC SOLID SHANK (ALLIANCE NO.2) INNER END	
TRAIN HEATING	ELECTRIC(BR)	
MAX.SPEED M.P.H.	90	75
MIN.RAD.CURVE CHAINS	3.5	
LIGHTING	FLUORESCENT & TUNGSTEN	
TARE WEIGHT TONNES	35	
GANGWAYS	BR STANDARD MK 2	
A.W.S.	FITTED	
TRAIN COMMUNICATION	NOT FITTED	
BUFFERS	RETRACTABLE SPINDLE-559 X 356 OVAL OUTER END ONLY	
VOLTAGE EQUIPMENT	25 KV	25 & 6.25 KV

TRACTION DATA FOR MULTIPLE UNITS

EMU- CLASS 312/0 GREAT NORTHERN OUTER SUBURBAN-CLASS 312/1 GREAT EASTERN OUTER SUBURBAN-CLASS 312/2 LONDON MIDLAND OUTER SUBURBAN.
 INTRODUCED 1975.
 VOLTAGE 25 KV A.C.OVERHEAD OR 25 & 6.25 KV A.C.OVERHEAD-SEE VARIANTS.

BASIC TYPE

EF 213 0A-CLASS 312/0

VARIANTS

- 0B CLASS 312/2 MAX.SPEED 75.
- 1A CLASS 312/1-25 & 6.25 KV EQUIPMENT.
- 0C CLASS 312/0 FACELIFTED.

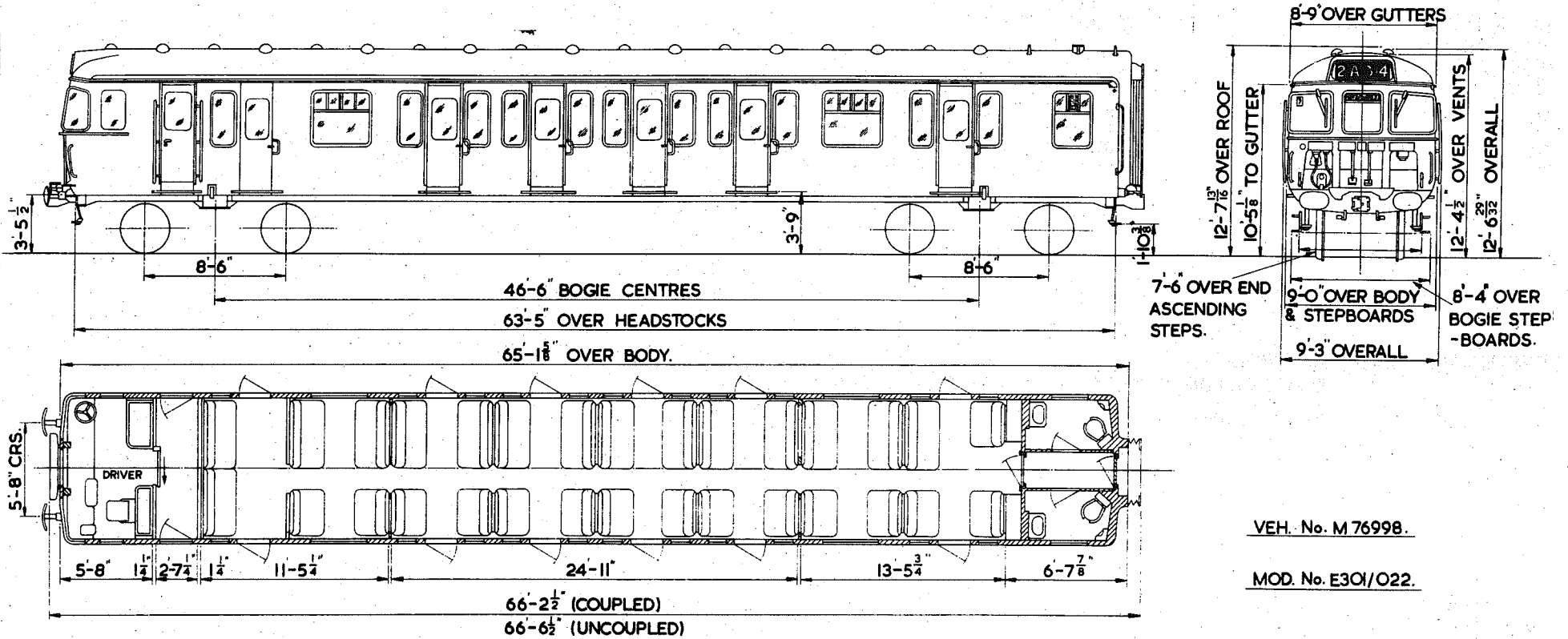

VEH. No. M 76998.

MOD. No. E30I/O22.

SEATS	75
TOILETS	2
COMPARTMENTS	-
GUARDS COMPARTMENTS	-
VENTILATION	-
CATERING EQUIPMENT	-

ORIGINAL DIAGRAMS FOR REFERENCE:-
BR 482

ISSUE 3 DATE DEC 85

EF 214

BRAKES
BOGIE/SUSPENSION
BODY CONSTRUCTION
COUPLINGS

TRAIN HEATING
MAX. SPEED M.P.H.
MIN. RAD. CURVE CHAINS
LIGHTING
TARE WEIGHT TONNES
GANGWAYS
A.W.S.
TRAIN COMMUNICATION
BUFFERS

BASIC TYPE

ELECTRO PNEUMATIC
B4/AM10 T
STEEL
AUTOMATIC DROPHEAD(BUCKEYE) OUTER END-AUTOMATIC SOLID SHANK
(BUCKEYE) INNER END
ELECTRIC(BR)
75
3.5
TUNGSTEN
35
EXPRESS ELECTRIC INNER END ONLY
FITTED
NOT FITTED
RETRACTABLE SPINDLE-559 X 356 OVAL OUTER END ONLY

ALTERNATIVES

PUBLIC ADDRESS

TRACTION DATA FOR MULTIPLE UNITS

EMU- EUSTON-BIRMINGHAM-MANCHESTER & LIVERPOOL. INTRODUCED 1966.
VOLTAGE 25 KV A.C.OVERHEAD

BASIC TYPE

EF 214 0A

VARIANTS

1B FACELIFTED, PUBLIC ADDRESS FITTED.

BATTERY DRIVING TRAILER SECOND

CLASS 309/1

BDTS

EF 216

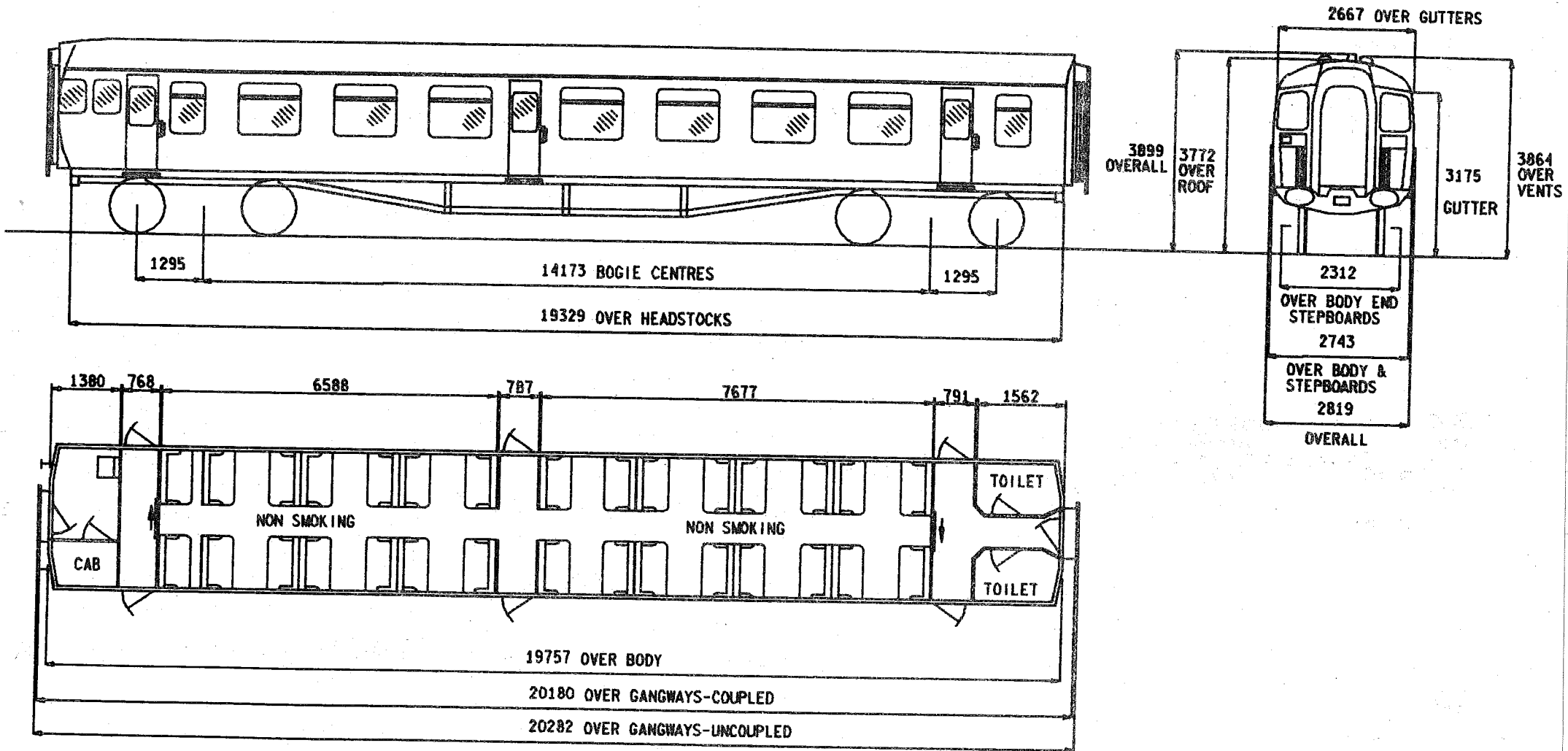

SEATS	60
TOILETS	2
COMPARTMENTS	-
GUARDS COMPARTMENTS	-
VENTILATION	-
CATERING EQUIPMENT	-

ISSUE 1 DATE OCT '86

EF 216

BRAKES
BOGIE/SUSPENSION
BODY CONSTRUCTION
COUPLINGS

TRAIN HEATING
MAX.SPEED M.P.H.
MIN.RAD.CURVE CHAINS
LIGHTING
TARE WEIGHT TONNES
GANGWAYS
TRAIN COMMUNICATION
BUFFERS

BASIC TYPE

ELECTRO PNEUMATIC
COMMONWEALTH
STEEL
AUTOMATIC DROPHEAD(BUCKEYE) OUTER END
AUTOMATIC SOLID SHANK(ALLIANCE NO.2) INNER END
ELECTRIC(BR)
100
3.5
FLUORESCENT
41
PULLMAN
PUBLIC ADDRESS
RETRACTABLE SPINDLE 559x356 OVAL-OUTER END ONLY

ALTERNATIVES

TRACTION DATA FOR MULTIPLE UNITS

EMU- LIVERPOOL ST.-CLACTON & WALTON INTRODUCED 1962, REFURBISHED 1985.
VOLTAGE 25 & 6.25 KV A.C.OVERHEAD.

BASIC TYPE

EF 216 0A

VARIANTS

NONE

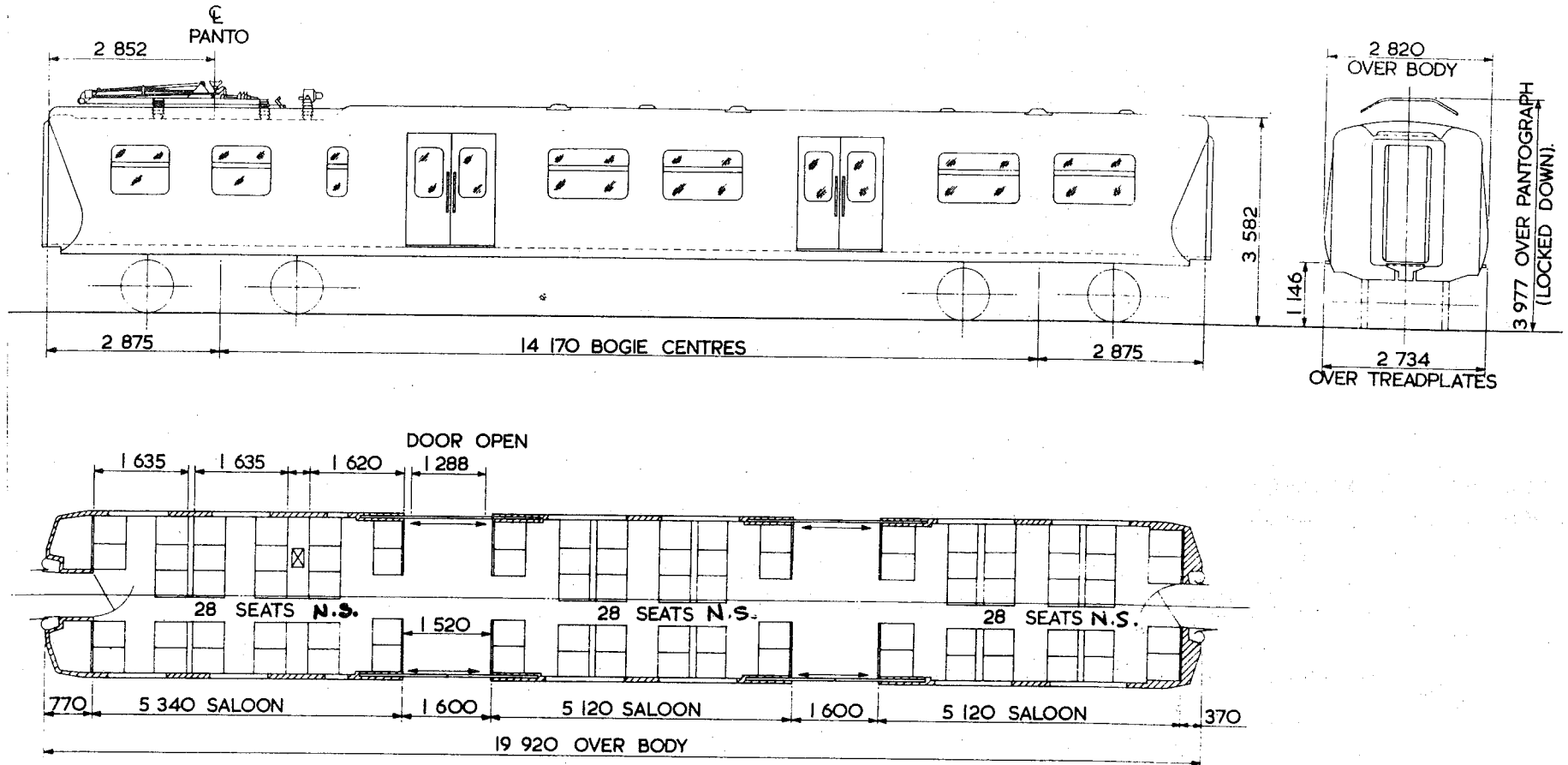

NS NON SMOKING

SEATS	84
TOILETS	-
COMPARTMENTS	-
GUARDS COMPARTMENTS	-
VENTILATION	-
CATERING EQUIPMENT	-

ORIGINAL DIAGRAMS FOR REFERENCE:-
BR 467

ISSUE 5 DATE NOV 87

EH 217

BRAKES
BOGIE/SUSPENSION
BODY CONSTRUCTION
COUPLINGS
TRAIN HEATING
MAX. SPEED M.P.H.
MIN. RAD. CURVE CHAINS
LIGHTING
TARE WEIGHT TONNES
GANGWAYS
TRAIN COMMUNICATION
BUFFERS

BASIC TYPE

ELECTRO PNEUMATIC
BX1/T_e & BX1/T_f (ONE OF EACH)
STEEL UNDERFRAME & BODY FRAMING-ALUMINIUM BODY & ROOF
BAR
ELECTRIC-DUCTED WARM AIR
75
3.5
FLUORESCENT
32
FLEXIBLE DIAPHRAGM/RIGID (GRP)
PUBLIC ADDRESS
NOT FITTED

ALTERNATIVES

TRACTION DATA FOR MULTIPLE UNITS

EMU- LIVERPOOL ST.-SHENFIELD INNER SUBURBAN
VOLTAGE 25 KV A.C. OVERHEAD
EQUIPPED WITH PANTOGRAPH & TRANSFORMER

BASIC TYPE

EH 217 OA

VARIANTS

NONE

DRIVING TRAILER COMPOSITE

CLASS 305/2
308/1

BBTC

EF 302

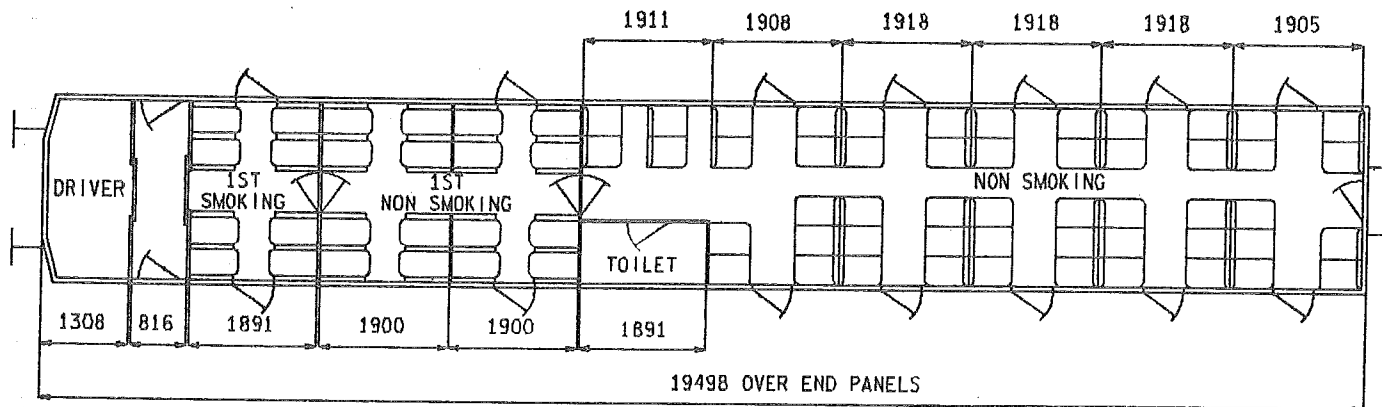
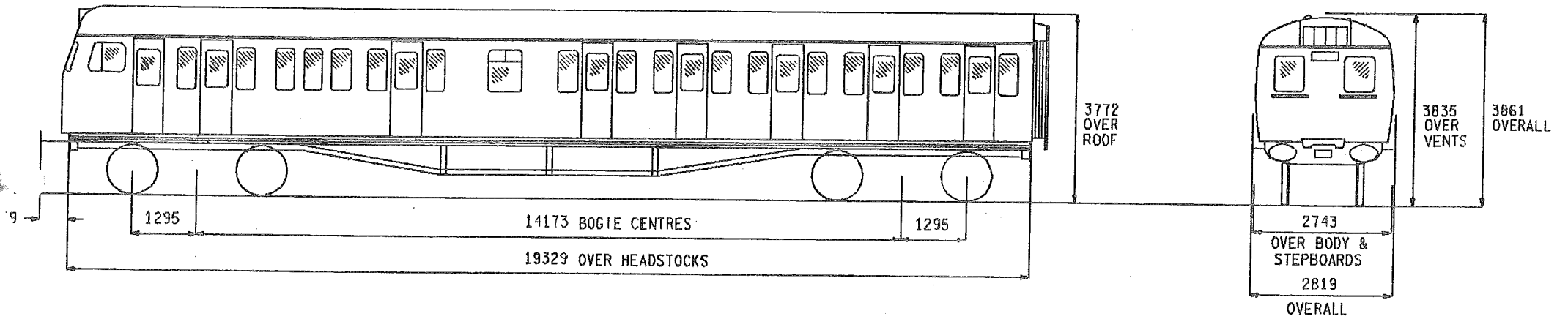

SEATS	24 FIRST CLASS, 52 SECOND CLASS
TOILETS	1
COMPARTMENTS	-
GUARDS COMPARTMENTS	-
VENTILATION	-
CATERING EQUIPMENT	-

ISSUE 1 DATE APR '83

EF 302

BRAKES
BOGIE/SUSPENSION
BODY CONSTRUCTION
COUPLINGS

TRAIN HEATING
MAX.SPEED M.P.H.
MIN.RAD.CURVE CHAINS
LIGHTING
TARE WEIGHT TONNES
GANGWAYS
A.W.S.
TRAIN COMMUNICATION
BUFFERS

BASIC TYPE

ELECTRO PNEUMATIC
GRESLEY ET5
STEEL
AUTOMATIC DROPHEAD(BUCKEYE) OUTER END-AUTOMATIC SOLID SHANK
(ALLIANCE NO 2) INNER END
ELECTRIC(BR)
75
3.5
FLUORESCENT
36(EST)
PULLMAN WITH RIGID(GRP) INNER PANELS INNER END ONLY
FITTED
DRIVER/GUARD-PUBLIC ADDRESS
RETRACTABLE SPINDLE-559 X 356 OVAL OUTER END-CENTRE INNER END

ALTERNATIVES

GRESLEY ET8

TRACTION DATA FOR MULTIPLE UNITS

EMU- GREAT EASTERN OUTER SUBURBAN. INTRODUCED CLASS 305/2 1960, CLASS 308/1 1961. REFURBISHED 1983.
VOLTAGE 25 & 6.25 KV A.C.OVERHEAD

BASIC TYPE

EF 302 0A-REFURBISHED

VARIANTS

0B CLASS 308/1 GRESLEY ET8 BOGIES.

BATTERY DRIVING TRAILER COMPOSITE

CLASS 302

BDTC

EF 303

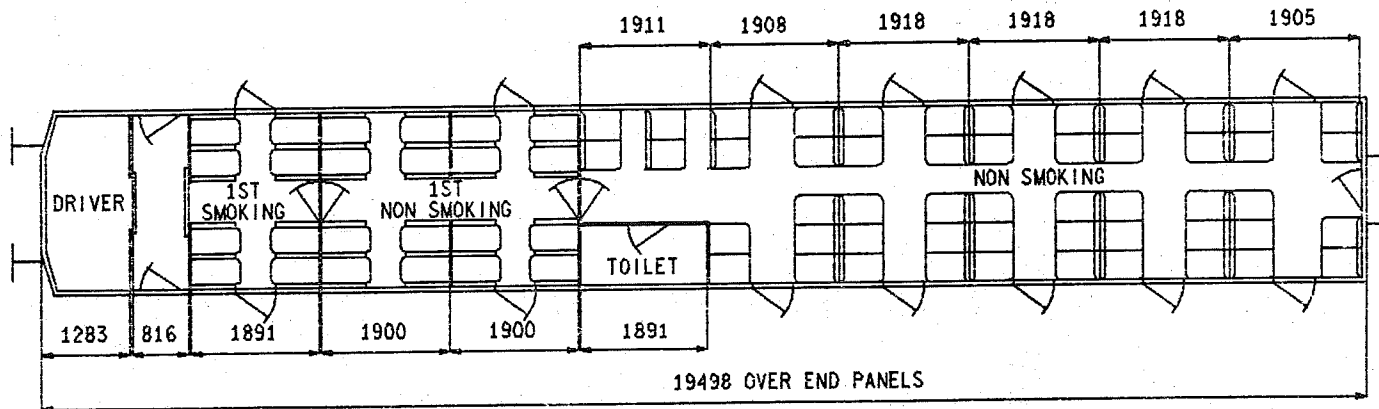
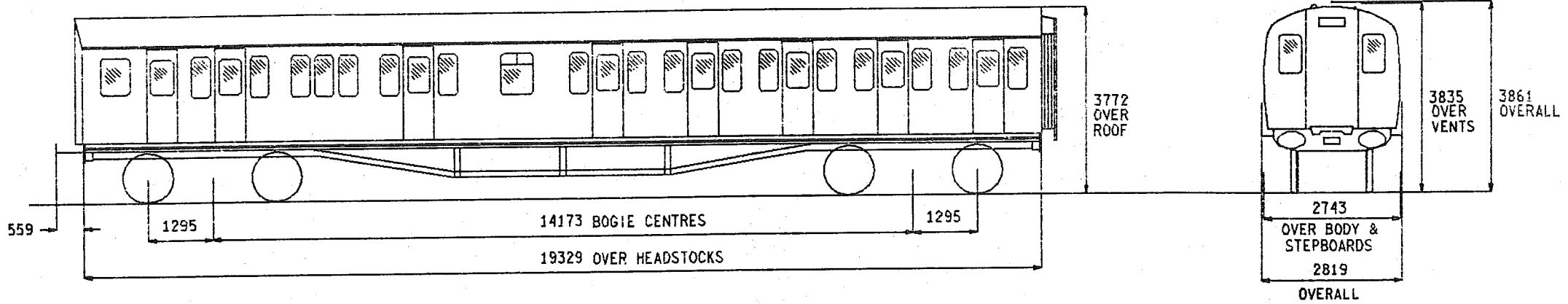

- | | |
|---------------------|---------------------------------|
| SEATS | 24 FIRST CLASS, 52 SECOND CLASS |
| TOILETS | 1 |
| COMPARTMENTS | - |
| GUARDS COMPARTMENTS | - |
| VENTILATION | - |
| CATERING EQUIPMENT | - |

ISSUE 2 DATE MAR 87

EF 303

BASIC TYPE

ALTERNATIVES

BRAKES
BOGIE/SUSPENSION
BODY CONSTRUCTION
COUPLINGS

ELECTRO PNEUMATIC
GRESLEY ET2
STEEL
AUTOMATIC DROPHEAD(BUCKEYE) OUTER END-AUTOMATIC SOLID SHANK
(ALLIANCE NO 2) INNER END
ELECTRIC(BR)
75
3.5
FLUORESCENT
38(EST)
PULLMAN WITH RIGID(GRP) INNER PANELS INNER END ONLY
FITTED
DRIVER/GUARD-PUBLIC ADDRESS
RETRACTABLE SPINDLE-559 X 356 OVAL OUTER END-CENTRE INNER END

B4, B5

TRAIN HEATING
MAX. SPEED M.P.H.
MIN. RAD. CURVE CHAINS
LIGHTING
TARE WEIGHT TONNES
GANGWAYS
A.W.S.
TRAIN COMMUNICATION
BUFFERS

TRACTION DATA FOR MULTIPLE UNITS

EMU- GREAT EASTERN OUTER SUBURBAN. INTRODUCED 1958, REFURBISHED 1983.
VOLTAGE 25 & 6.25 KV A.C. OVERHEAD

BASIC TYPE

EF 303 OA-REFURBISHED

VARIANTS

OB B4 BOGIES.
OC B5 BOGIES.

BATTERY DRIVING TRAILER COMPOSITE

CLASS 305/2
308/1

BDTC

EF 304

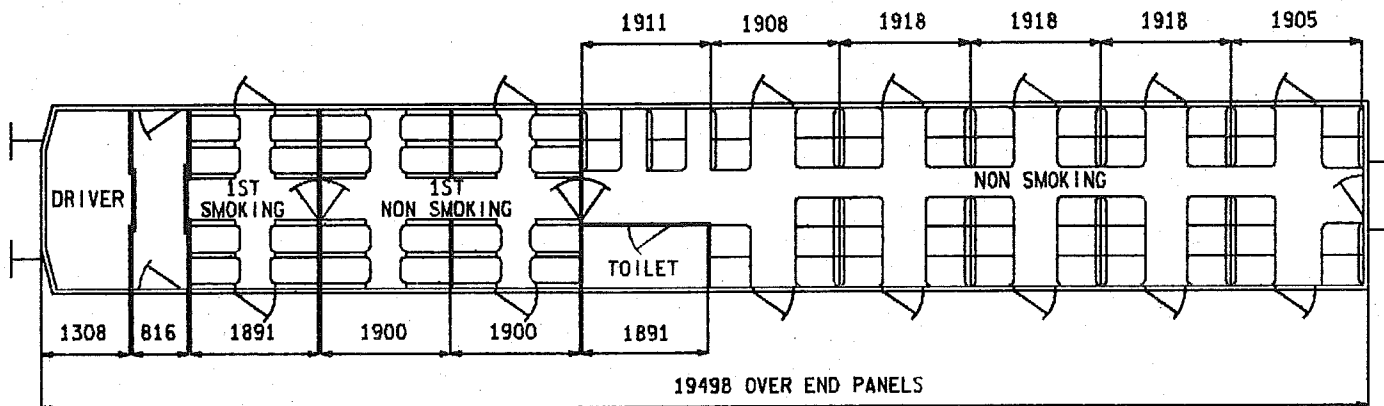
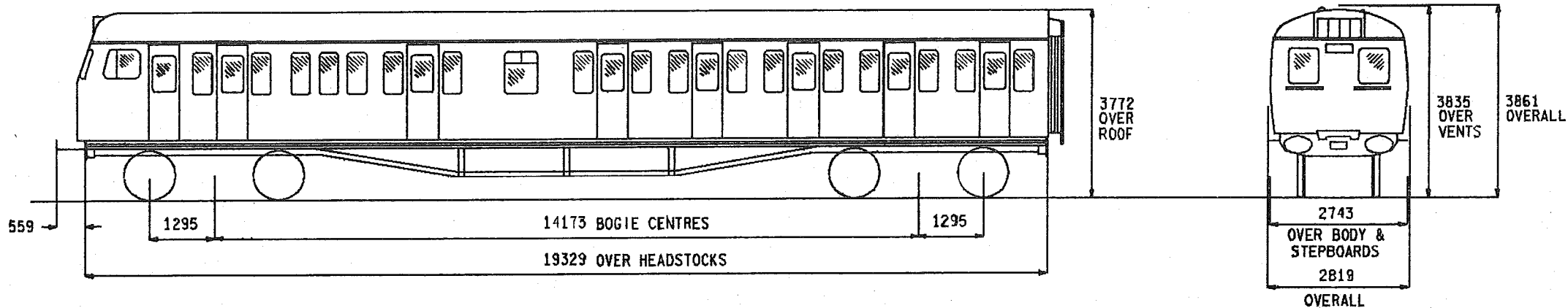

SEATS
 TOILETS
 COMPARTMENTS
 GUARDS COMPARTMENTS
 VENTILATION
 CATERING EQUIPMENT

24 FIRST CLASS, 52 SECOND CLASS
 1
 -
 -
 -
 -

EF 304

BRAKES
BOGIE/SUSPENSION
BODY CONSTRUCTION
COUPLINGS

TRAIN HEATING
MAX. SPEED M.P.H.
MIN. RAD. CURVE CHAINS
LIGHTING
TARE WEIGHT TONNES
GANGWAYS
A.W.S.
TRAIN COMMUNICATION
BUFFERS

BASIC TYPE

ELECTRO PNEUMATIC
GRESLEY ET5
STEEL
AUTOMATIC DROPHEAD (BUCKEYE) OUTER END-AUTOMATIC SOLID SHANK
(ALLIANCE NO 2) INNER END
ELECTRIC (BR)
75
3.5
FLUORESCENT
36 (EST)
PULLMAN WITH RIGID (GRP) INNER PANELS INNER END ONLY
FITTED
DRIVER/GUARD-PUBLIC ADDRESS
RETRACTABLE SPINDLE-559 X 356 OVAL OUTER END-CENTRE INNER END

ALTERNATIVES

GRESLEY ET8

TRACTION DATA FOR MULTIPLE UNITS

EMU- GREAT EASTERN OUTER SUBURBAN. INTRODUCED CLASS 305/2 1960, CLASS 308/1 1961. REFURBISHED 1983.
VOLTAGE 25 & 6.25 KV A.C. OVERHEAD

BASIC TYPE

EF 304 0A-REFURBISHED

VARIANTS

0B CLASS 308/1 GRESLEY ET8 BOGIES.

BATTERY DRIVING TRAILER COMPOSITE

CLASS 309/2
309/3

BBTC

EF 305

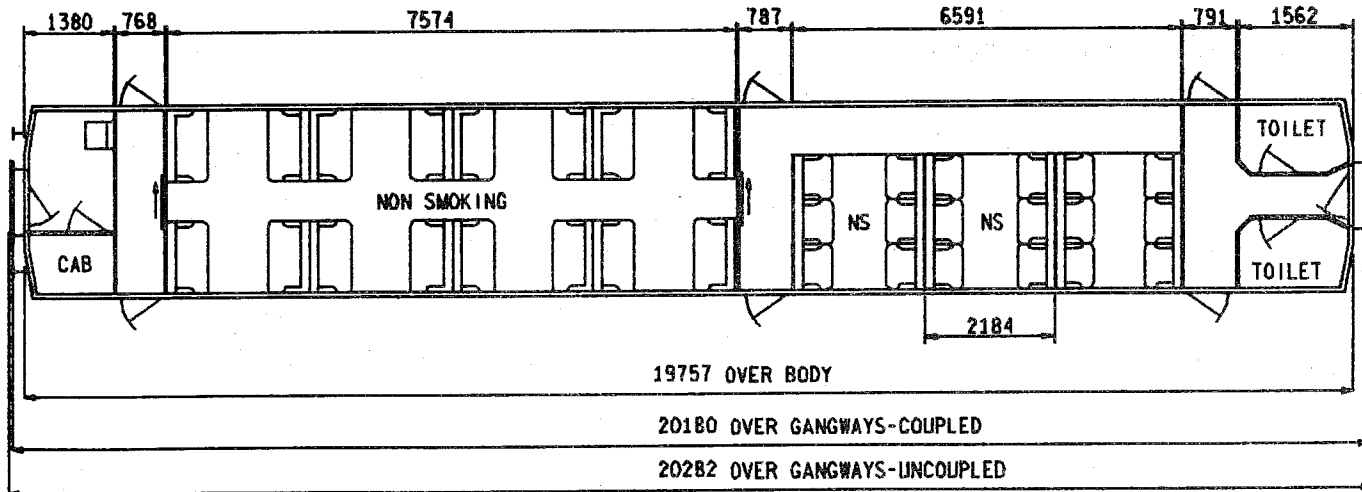
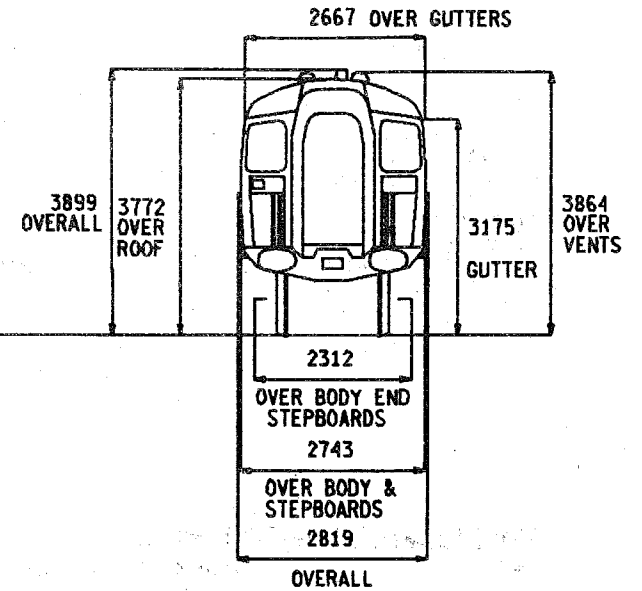
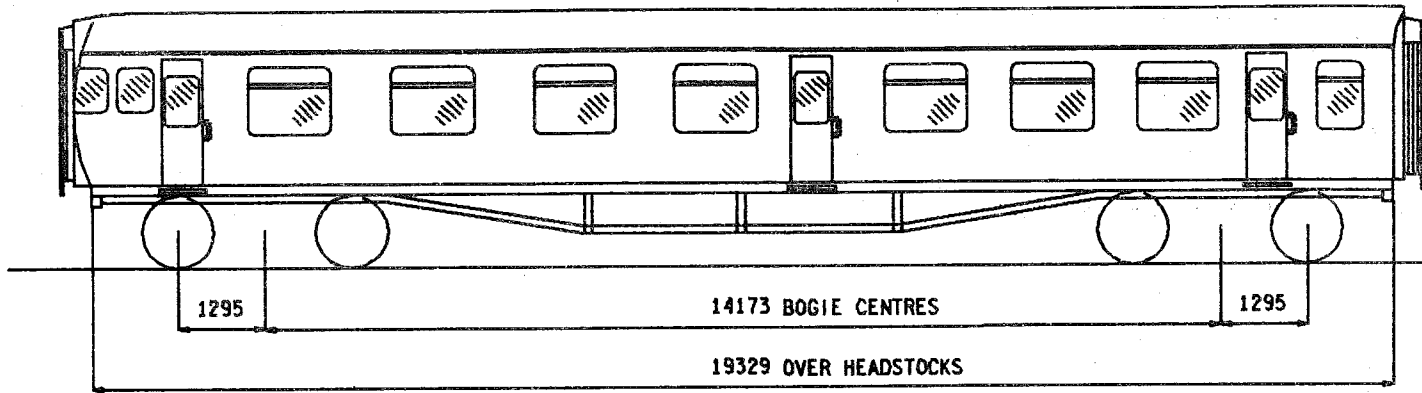

SEATS
TOILETS
COMPARTMENTS
GUARDS COMPARTMENTS
VENTILATION
CATERING EQUIPMENT

32 SECOND CLASS 18 FIRST CLASS
2
3
-
-
-

ISSUE DATE
1 OCT '86

EF 305

BRAKES
BOGIE/SUSPENSION
BODY CONSTRUCTION
COUPLINGS

TRAIN HEATING
MAX. SPEED M.P.H.
MIN. RAD. CURVE CHAINS
LIGHTING
TARE WEIGHT TONNES
GANGWAYS
TRAIN COMMUNICATION
BUFFERS

BASIC TYPE

ELECTRO PNEUMATIC
COMMONWEALTH
STEEL
AUTOMATIC DROPHEAD(BUCKEYE) OUTER END
AUTOMATIC SOLID SHANK(ALLIANCE NO.2) INNER END
ELECTRIC(BR)
100
3.5
FLUORESCENT
37.5
PULLMAN
PUBLIC ADDRESS
RETRACTABLE SPINDLE-559x356 OVAL-OUTER END ONLY

ALTERNATIVES

TRACTION DATA FOR MULTIPLE UNITS

EMU- LIVERPOOL ST.-CLACTON & WALTON INTRODUCED 1962, REFURBISHED 1985.
VOLTAGE 25 & 6.25 KV A.C.OVERHEAD.

BASIC TYPE

EF 305 0A

VARIANTS

NONE

DRIVING TRAILER BRAKE SECOND

CLASS 501

DTBS

EG 201

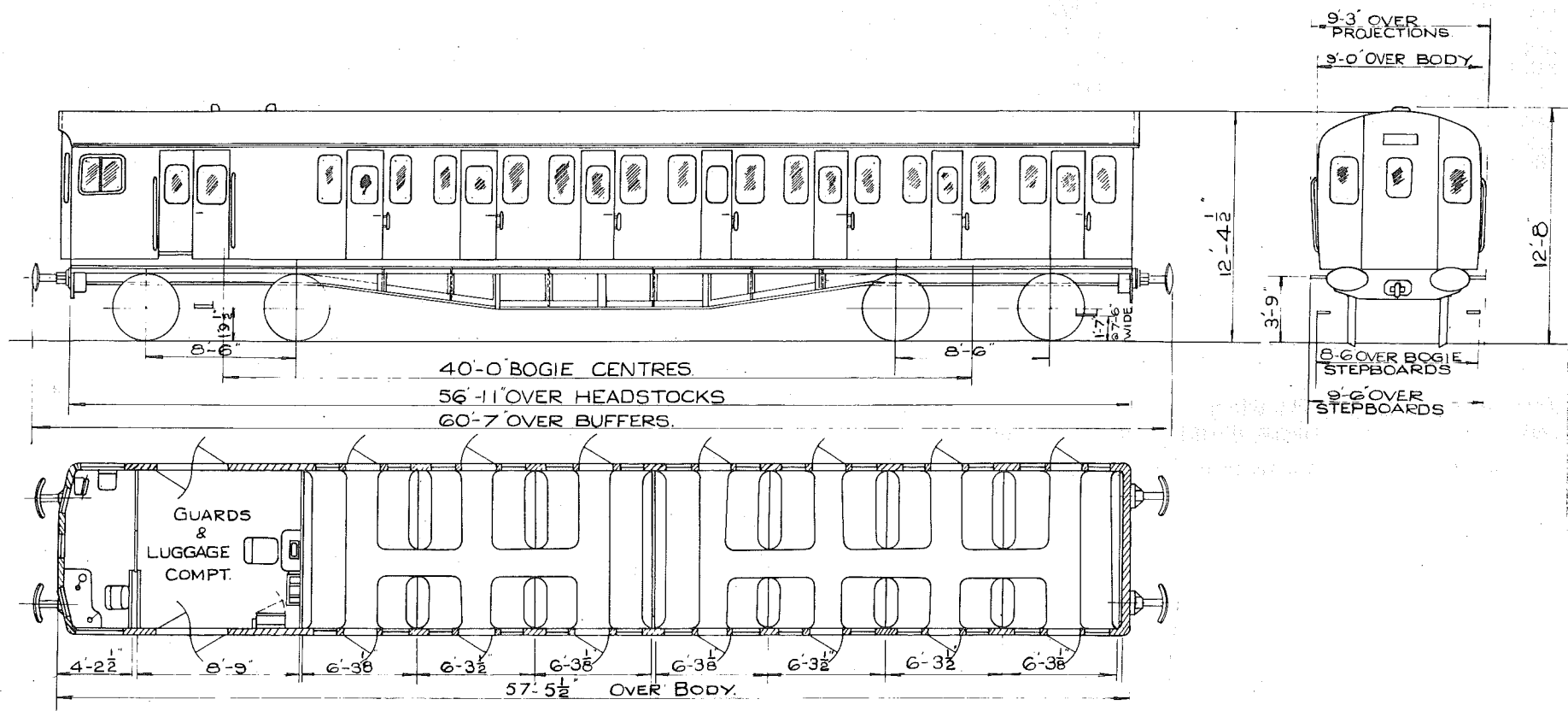

SEATS	74
TOILETS	-
COMPARTMENTS	-
GUARDS COMPARTMENTS	1
VENTILATION	-
CATERING EQUIPMENT	-

ORIGINAL DIAGRAMS FOR REFERENCE.-
BR 410

ISSUE 1 DATE SEP' 80

EG 201

BRAKES
BOGIE/SUSPENSION
BODY CONSTRUCTION
COUPLINGS
TRAIN HEATING
MAX. SPEED M.P.H.
MIN. RAD. CURVE CHAINS
LIGHTING
TARE WEIGHT TONNES
GANGWAYS
A.V.S.
TRAIN COMMUNICATION
BUFFERS

BASIC TYPE

ELECTRO PNEUMATIC
CLASS 501 TRAILER
STEEL
SCREW
ELECTRIC (BR)
70
3.5
ELECTRIC
30.5
NOT FITTED
NOT FITTED
NOT FITTED
SPINDLE-559 X 356 OVAL-

ALTERNATIVES

TRACTION DATA FOR MULTIPLE UNITS

EMU- LONDON DISTRICT INTRODUCED 1957
VOLTAGE 630 VOLTS D.C. THIRD RAIL

BASIC TYPE

EG 201 0A

VARIANTS

NONE

DRIVING TRAILER BRAKE SECOND

CLASS 304/1

DTBS

EG 202

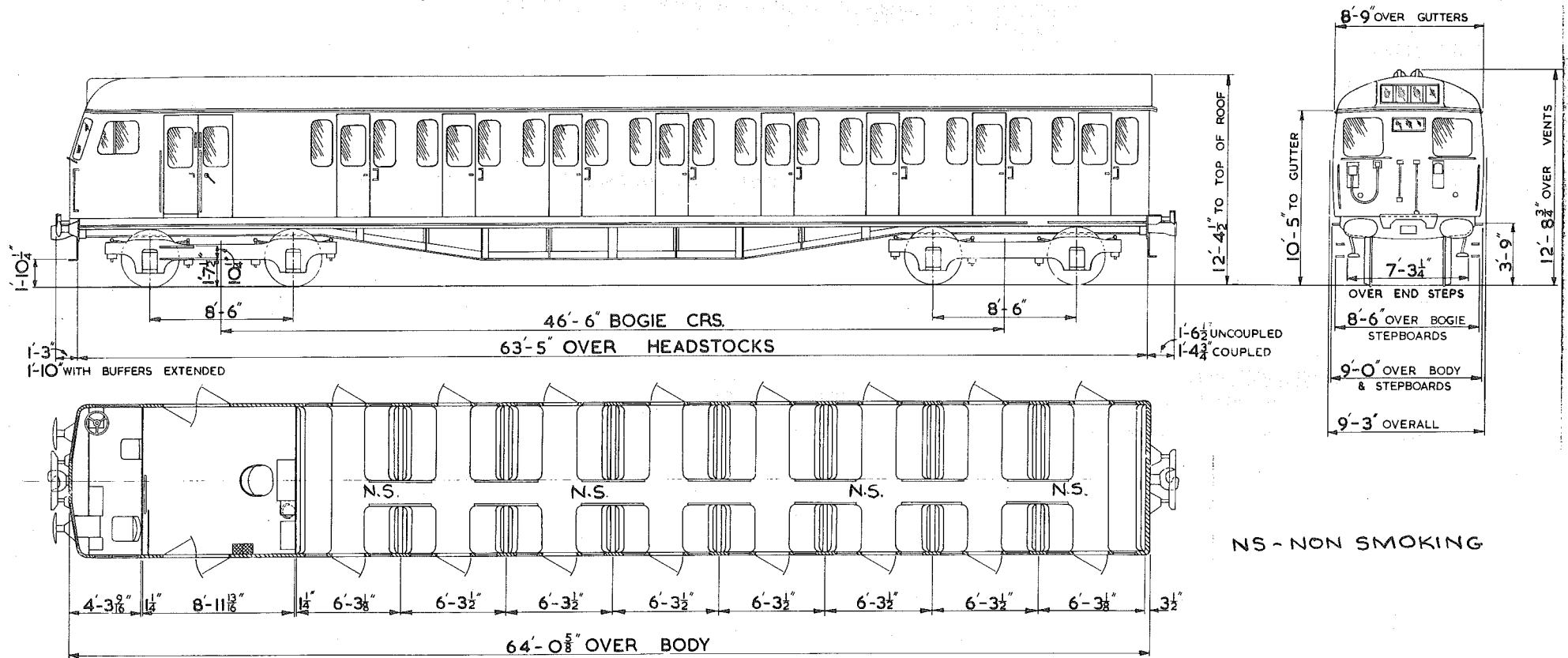

SEATS	82
TOILETS	-
COMPARTMENTS	-
GUARDS COMPARTMENTS	1
VENTILATION	-
CATERING EQUIPMENT	-

ORIGINAL DIAGRAMS FOR REFERENCE -
BR 411

ISSUE 1 DATE SEP' 80

EG 202

BRAKES
BOGIE/SUSPENSION
BODY CONSTRUCTION
COUPLINGS

TRAIN HEATING
MAX. SPEED M.P.H.
MIN. RAD. CURVE CHAINS
LIGHTING
TARE WEIGHT TONNES
GANGWAYS
A. V. S.
TRAIN COMMUNICATION
BUFFERS

BASIC TYPE

ELECTRO PNEUMATIC
GRESLEY ET8
STEEL
AUTOMATIC DROPHEAD (BUCKEYE) OUTER END, AUTOMATIC SOLID SHANK
(ALLIANCE NO 2) INNER END
ELECTRIC (BR)
75
3.5
ELECTRIC
32
NOT FITTED
FITTED
NOT FITTED
RETRACTABLE SPINDLE-559 X 356 OVAL-OUTER END ONLY

ALTERNATIVES

TRACTION DATA FOR MULTIPLE UNITS

EMU- EUSTON-BIRMINGHAM-MANCHESTER & LIVERPOOL INTRODUCED 1960.
VOLTAGE 25 KV A.C. OVERHEAD.

BASIC TYPE

EG 202 0A

VARIANTS

NONE

DRIVING TRAILER BRAKE SECOND

CLASS 304/2
304/3

DTBS

EG 203

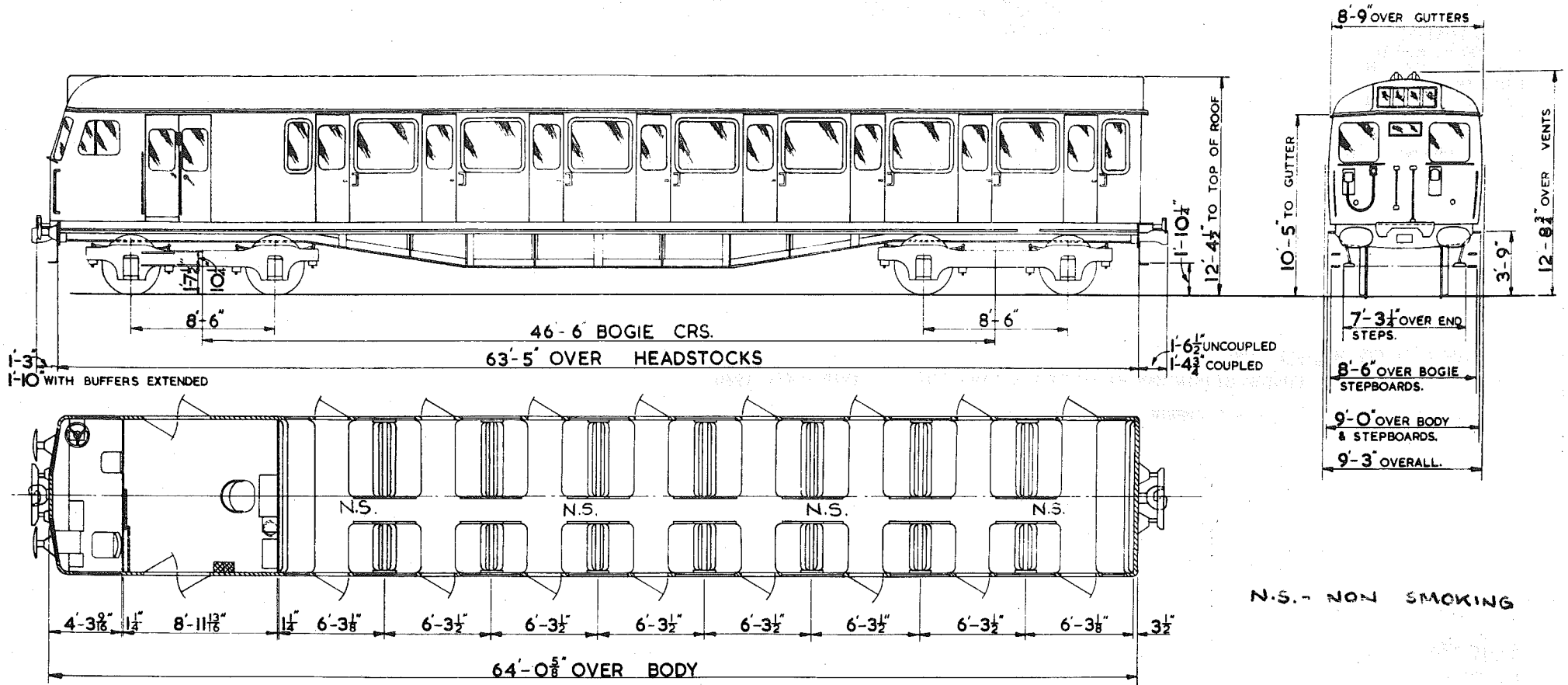

SEATS	82
TOILETS	-
COMPARTMENTS	-
GUARDS COMPARTMENTS	1
VENTILATION	-
CATERING EQUIPMENT	-

ORIGINAL DIAGRAMS FOR REFERENCE.-
BR 412

ISSUE 2 DATE DEC '81

EG 203

BASIC TYPE

ALTERNATIVES

BRAKES
BOGIE/SUSPENSION
BODY CONSTRUCTION
COUPLINGS

ELECTRO PNEUMATIC
GRESLEY ET8
STEEL
AUTOMATIC DROPHEAD (BUCKEYE) OUTER END-AUTOMATIC SOLID SHANK
(ALLIANCE NO.2) INNER END
ELECTRIC (BR)
75
3.5
TUNGSTEN
32.5
NOT FITTED
FITTED
NOT FITTED
RETRACTABLE SPINDLE-559 X 356 OVAL OUTER END ONLY

TRAIN HEATING
MAX. SPEED M.P.H.
MIN. RAD. CURVE CHAINS
LIGHTING
TARE WEIGHT TONNES
GANGWAYS
A.V.S.
TRAIN COMMUNICATION
BUFFERS

TRACTION DATA FOR MULTIPLE UNITS

EMU- EUSTON-BIRMINGHAM-MANCHESTER & LIVERPOOL. INTRODUCED 1960.
VOLTAGE 25 KV A.C.OVERHEAD

BASIC TYPE

EG 203 OA

VARIANTS

NONE

TRAILER FIRST

CLASS 437

TF

EH 160

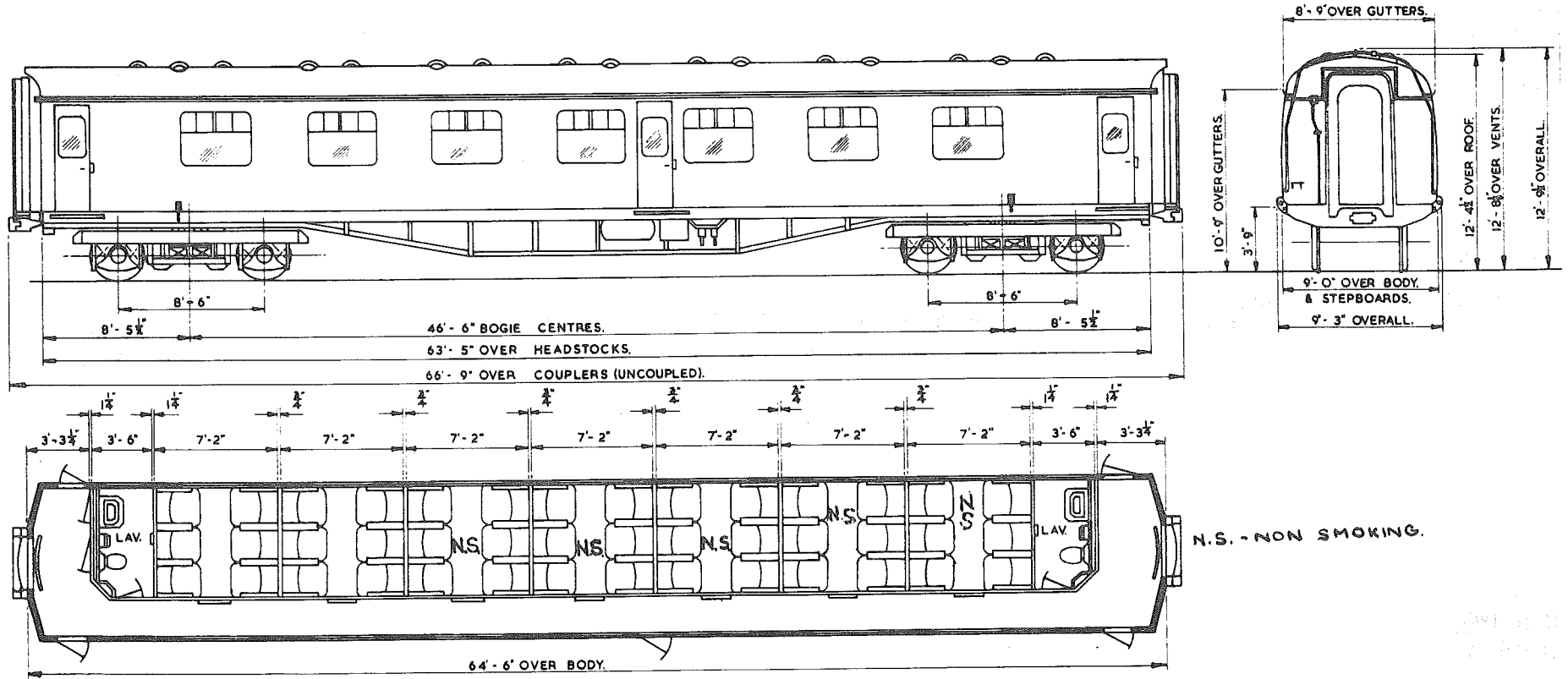

N.S. - NON SMOKING.

SEATS	42
TOILETS	2
COMPARTMENTS	7
GUARDS COMPARTMENTS	-
VENTILATION	-
CATERING EQUIPMENT	-

ORIGINAL DIAGRAMS FOR REFERENCE:-
BR 930A

ISSUE 4 DATE NOV 84

EH 160

BASIC TYPE

BRAKES
BOGIE/SUSPENSION
BODY CONSTRUCTION
COUPLINGS
TRAIN HEATING
MAX.SPEED M.P.H.
MIN.RAD.CURVE CHAINS
LIGHTING
TARE WEIGHT TONNES
GANGWAYS
TRAIN COMMUNICATION
BUFFERS
S.R.DESIGN REFERENCE CODE

ELECTRO PNEUMATIC
B5(S.R.)
STEEL
AUTOMATIC SOLID SHANK(ALLIANCE NO.2)
ELECTRIC(BR)
90
3.5
TUNGSTEN
33.5
EXPRESS ELECTRIC
NOT FITTED
NOT FITTED
BU

ALTERNATIVES

BU 1A

TRACTION DATA FOR MULTIPLE UNITS

EMU- TRAILER UNIT. INTRODUCED 1966 AS CLASS 491, RECLASSED 1984.

BASIC TYPE

EH 160 OA

VARIANTS

1B S.R.DESIGN REFERENCE CODE BU 1A.

TRAILER SECOND

CLASS 502

TS

EH 202

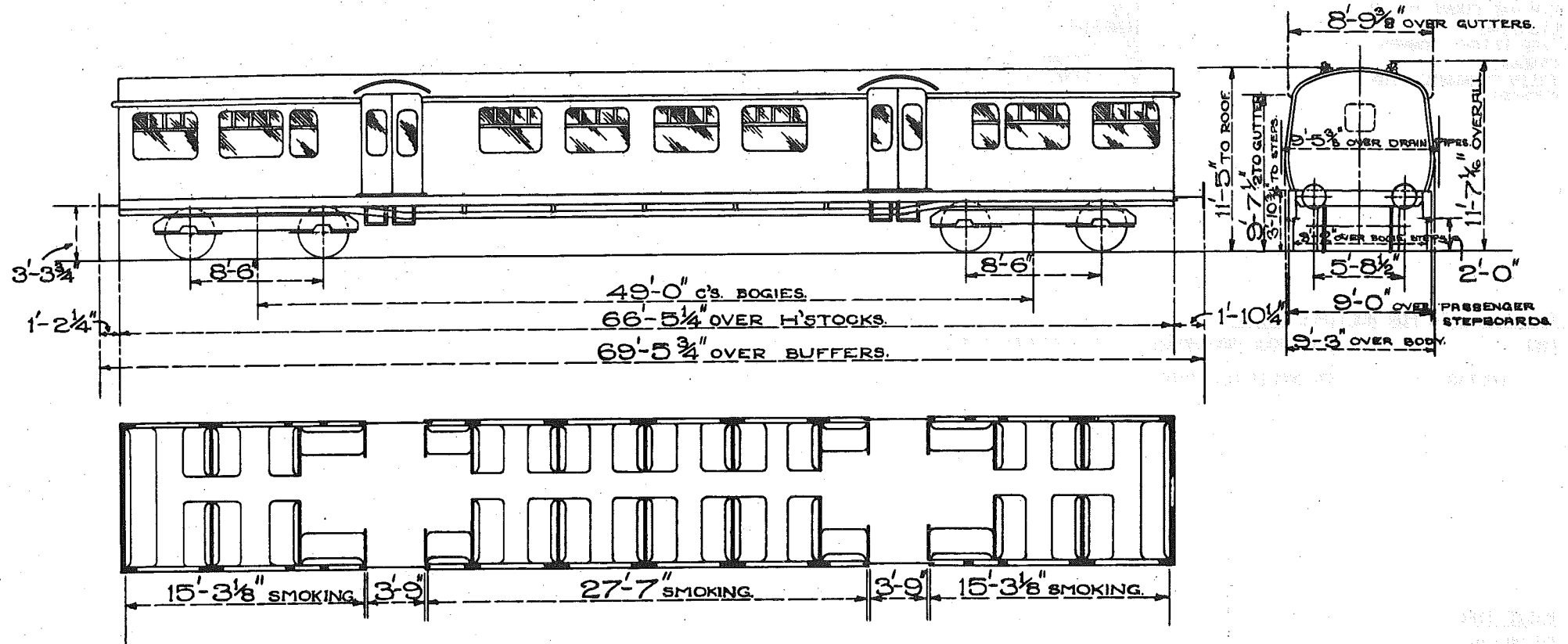

SEATS	102
TOILETS	-
COMPARTMENTS	-
GUARDS COMPARTMENTS	-
VENTILATION	-
CATERING EQUIPMENT	-

ORIGINAL DIAGRAMS FOR REFERENCE.-
LMS 379

ISSUE 2 DATE MAY '81

EH 202

BASIC TYPE

ELECTRO PNEUMATIC
CLASS 502 TRAILER
STEEL
SCREW (ONE END LOOSE COUPLED-ONE END CLOSE COUPLED)
ELECTRIC (BR)
65
3.5
TUNGSTEN
24
NOT FITTED
NOT FITTED
SELF CONTAINED-457 DIA.

ALTERNATIVES

BRAKES
BOGIE/SUSPENSION
BODY CONSTRUCTION
COUPLINGS
TRAIN HEATING
MAX. SPEED M.P.H.
MIN. RAD. CURVE CHAINS
LIGHTING
TARE WEIGHT TONNES
GANGWAYS
TRAIN COMMUNICATION
BUFFERS

TRACTION DATA FOR MULTIPLE UNITS

EMU- LIVERPOOL-SOUTHPORT. INTRODUCED 1939.
VOLTAGE 630 VOLTS D.C. THIRD RAIL

BASIC TYPE

EH 202 0A

VARIANTS

NONE

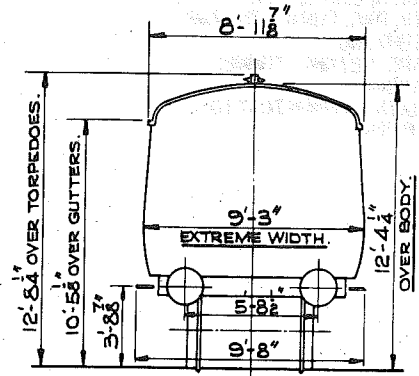
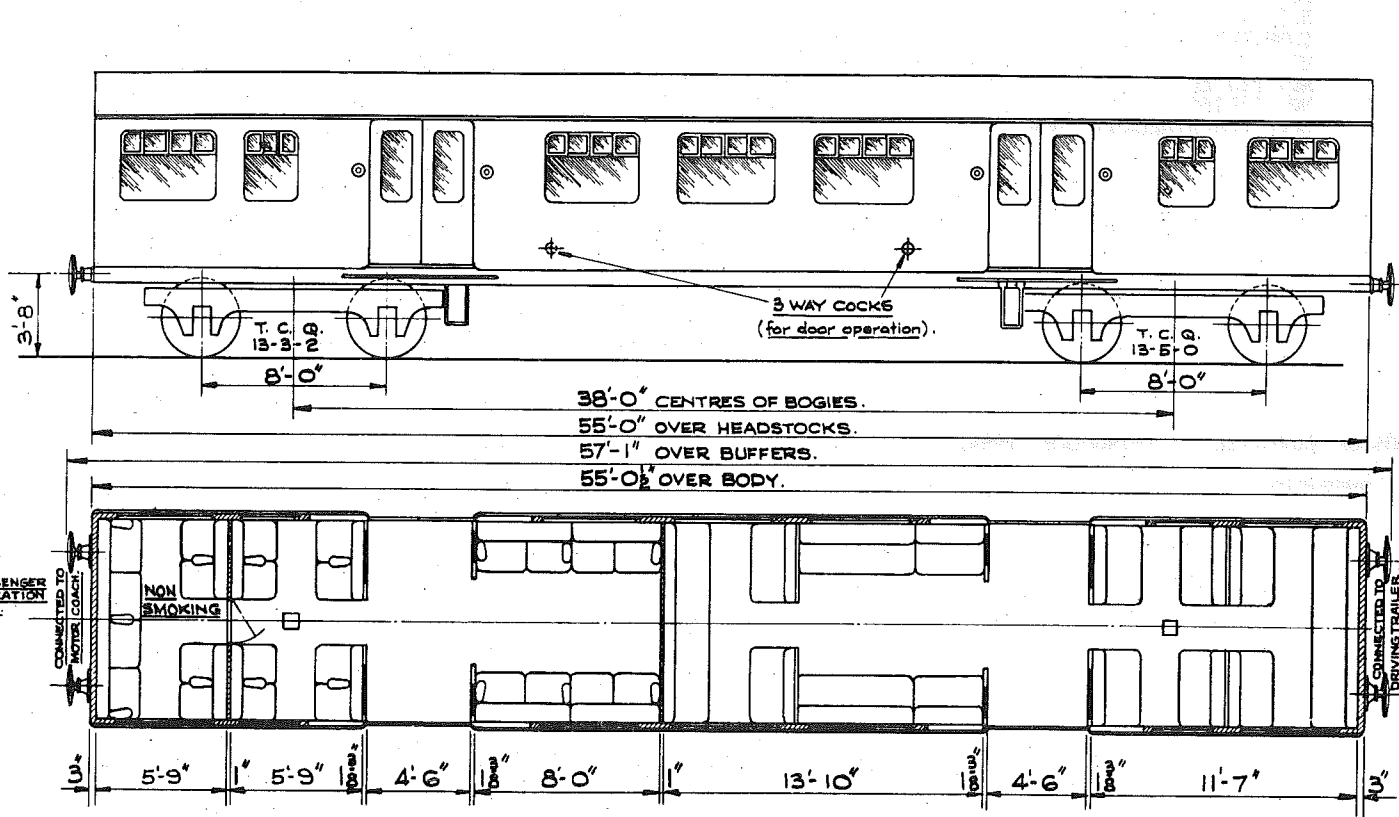

SEATS 62
TOILETS -
COMPARTMENTS -
GUARDS COMPARTMENTS -
VENTILATION -
CATERING EQUIPMENT -

ORIGINAL DIAGRAMS FOR REFERENCE.
LNE 366

ISSUE 2 DATE MAY 81

EH 204

BASIC TYPE

ALTERNATIVES

BRAKES
BOGIE/SUSPENSION
BODY CONSTRUCTION
COUPLINGS
TRAIN HEATING
MAX. SPEED H.P.H.
MIN. RAD. CURVE CHAINS
LIGHTING
TARE WEIGHT TONNES
GANGWAYS
TRAIN COMMUNICATION
BUFFERS

ELECTRO PNEUMATIC
CLASS 506 TRAILER
STEEL
SCREW
ELECTRIC (BR)
70
3.5
TUNGSTEN
27
NOT FITTED
NOT FITTED
SELF CONTAINED-559 OVAL



TRACTION DATA FOR MULTIPLE UNITS

EMU- MANCHESTER-GLOSSOP-HADFIELD. INTRODUCED 1954.
VOLTAGE 1500 VOLTS D.C.OVERHEAD



BASIC TYPE

EH 204 0A

VARIANTS

NONE

CLASS
- 506
559 OVAL
MANCHESTER-GLOSSOP
HADFIELD
INTRODUCED
1954

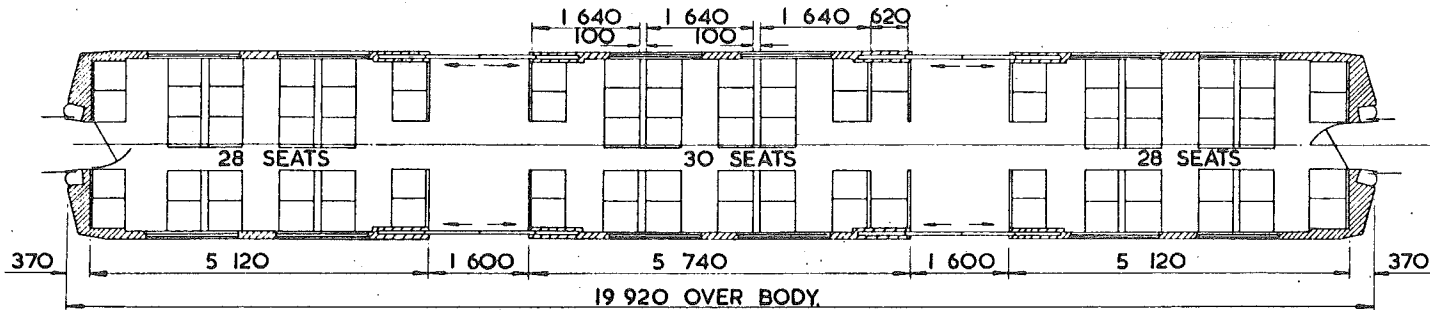
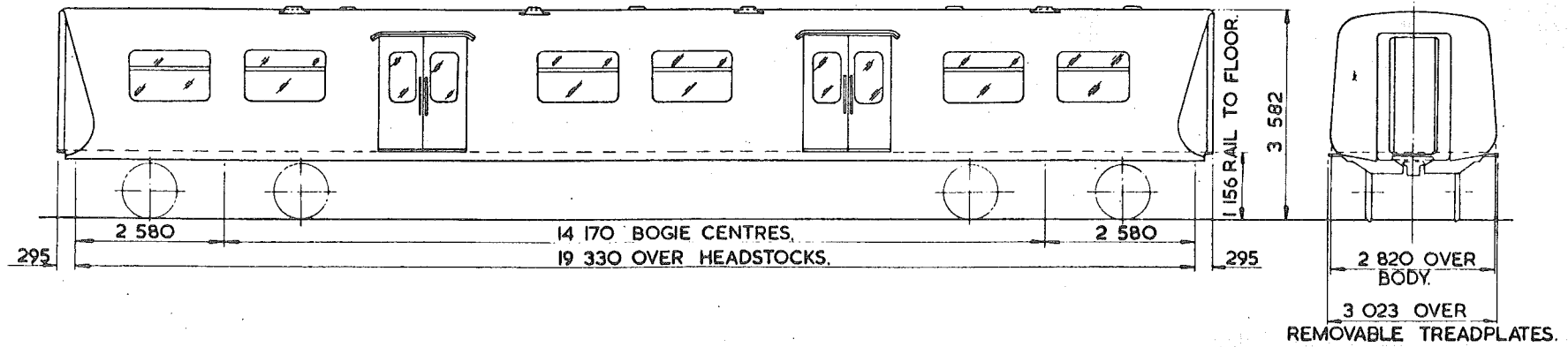

SEATS	86
TOILETS	-
COMPARTMENTS	-
GUARDS COMPARTMENTS	-
VENTILATION	-
CATERING EQUIPMENT	-

ORIGINAL DIAGRAMS FOR REFERENCE.-
BR 865

ISSUE 3 DATE AUG '82

EH 205

7. A. J. E. C. E. L. L.

BASIC TYPE

BRAKES
BOGIE/SUSPENSION
BODY CONSTRUCTION
COUPLINGS
TRAIN HEATING
MAX. SPEED M.P.H.
MIN. RAD. CURVE CHAINS
LIGHTING
TARE WEIGHT TONNES
GANGWAYS
TRAIN COMMUNICATION
BUFFERS

ELECTRO PNEUMATIC
BX1/Tc
STEEL UNDERFRAME & BODY FRAMING, ALUMINIUM BODY & ROOF
BAR
ELECTRIC-DUCTED WARM AIR
75
3.5
FLUORESCENT
25.5
FLEXIBLE DIAPHRAGM/RIGID (GRP) BOTH ENDS
PUBLIC ADDRESS
NOT FITTED

ALTERNATIVES

BX1/Td

TRACTION DATA FOR MULTIPLE UNITS

EMU- GARSTON-LIVERPOOL-SOUTHPORT INTRODUCED 1979.
VOLTAGE 600/750 VOLTS D.C. THIRD RAIL

BASIC TYPE

EH 205 0A

VARIANTS

0B BX1/Td BOGIES.

TRAILER SECOND

CLASS 310

TS

EH 208

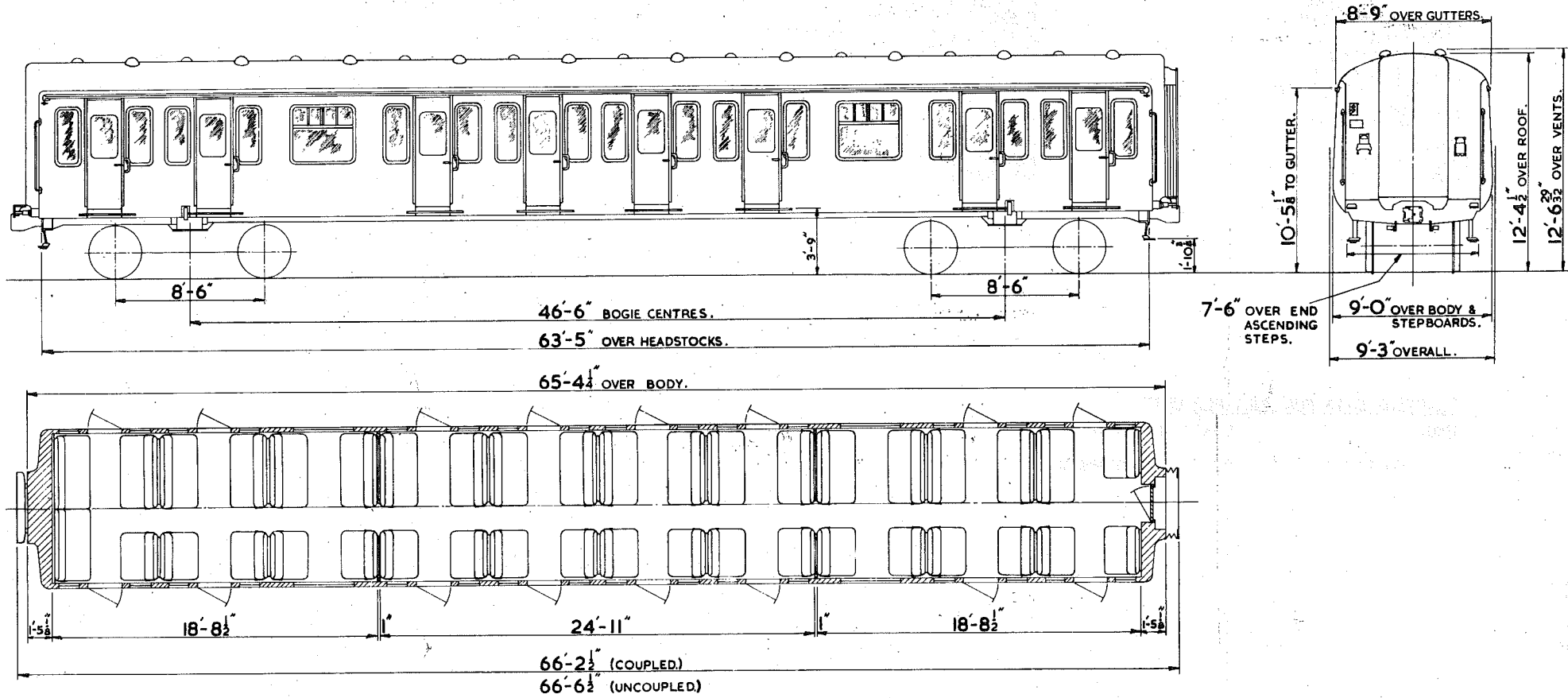

SEATS	100
TOILETS	-
COMPARTMENTS	-
GUARDS COMPARTMENTS	-
VENTILATION	-
CATERING EQUIPMENT	-

ORIGINAL DIAGRAMS FOR REFERENCE, -
BR 473

ISSUE 1 DATE SEP' 80

EH 208

BRAKES
BOGIE/SUSPENSION
BODY CONSTRUCTION
COUPLINGS
TRAIN HEATING
MAX. SPEED M.P.H.
MIN. RAD. CURVE CHAINS
LIGHTING
TARE WEIGHT TONNES
GANGWAYS
TRAIN COMMUNICATION
BUFFERS

BASIC TYPE

ELECTRO PNEUMATIC
B4/AM10 T
STEEL
AUTOMATIC SOLID SHANK (BUCKEYE)
ELECTRIC (BR)
75
3.5
ELECTRIC
31.5
EXPRESS ELECTRIC INNER END ONLY
NOT FITTED
NOT FITTED

ALTERNATIVES

TRACTION DATA FOR MULTIPLE UNITS

EMU- EUSTON-BIRMINGHAM-MANCHESTER & LIVERPOOL. INTRODUCED 1966.
VOLTAGE 25 KV A.C.OVERHEAD

BASIC TYPE

EH 208 0A

VARIANTS

NONE

BRITISH RAILWAYS
ELECTRIFICATION
DEPARTMENT
WILKINSON
MILNERS

TRAILER SECOND

CLASS 312/0
312/1
312/2

TS

EH 209

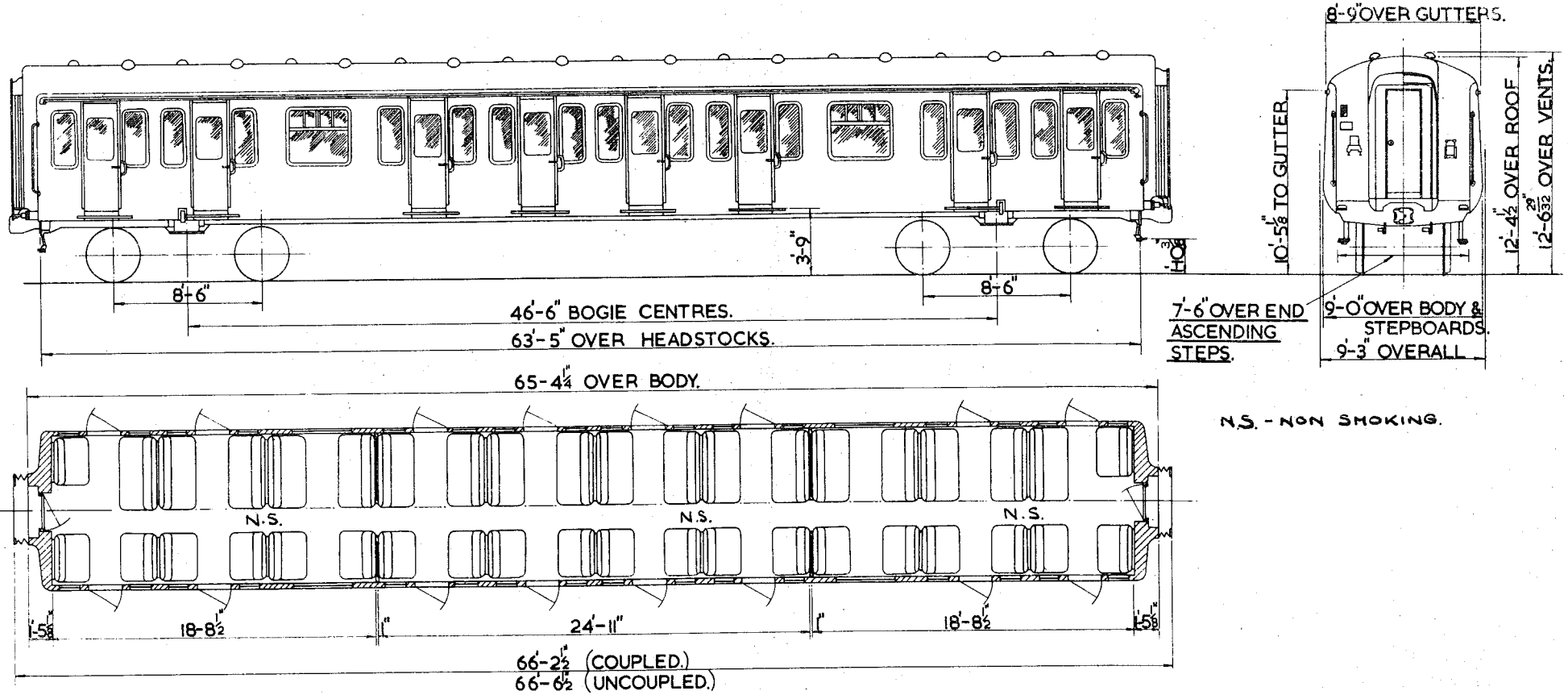

SEATS	98
TOILETS	-
COMPARTMENTS	-
GUARDS COMPARTMENTS	-
VENTILATION	-
CATERING EQUIPMENT	-

ORIGINAL DIAGRAMS FOR REFERENCE:-
BR 476

ISSUE DATE
3 MAR 87

EH 209

	<u>BASIC TYPE</u>	<u>ALTERNATIVES</u>
BRAKES	ELECTRO PNEUMATIC	
BOGIE/SUSPENSION	BT8b & BT8c(ONE OF EACH)	
BODY CONSTRUCTION	STEEL	
COUPLINGS	AUTOMATIC SOLID SHANK(ALLIANCE NO.2)	
TRAIN HEATING	ELECTRIC(BR)	75
MAX.SPEED M.P.H.	90	
MIN.RAD.CURVE CHAINS	3.5	
LIGHTING	FLUORESCENT	
TARE WEIGHT TONNES	30.5	
GANGWAYS	BR STANDARD MK 2	
TRAIN COMMUNICATION	NOT FITTED	
BUFFERS	NOT FITTED	
VOLTAGE EQUIPMENT	25 KV	25 & 6.25 KV

TRACTION DATA FOR MULTIPLE UNITS

EMU- CLASS 312/0 GREAT NORTHERN OUTER SUBURBAN-CLASS 312/1 GREAT EASTERN OUTER SUBURBAN-CLASS 312/2 LONDON MIDLAND OUTER SUBURBAN.
INTRODUCED 1975.
VOLTAGE 25 KV A.C.OVERHEAD OR 25 & 6.25 KV A.C.OVERHEAD-SEE VARIANTS.

BASIC TYPE

EH 209 OA-CLASS 312/0

VARIANTS

OB CLASS 312/2-MAX.SPEED 75.
1A CLASS 312/1-25 & 6.25 KV EQUIPMENT.
OC CLASS 312/0-FACELIFTED.

TRAILER SECOND

CLASS 313

TS

EH 210

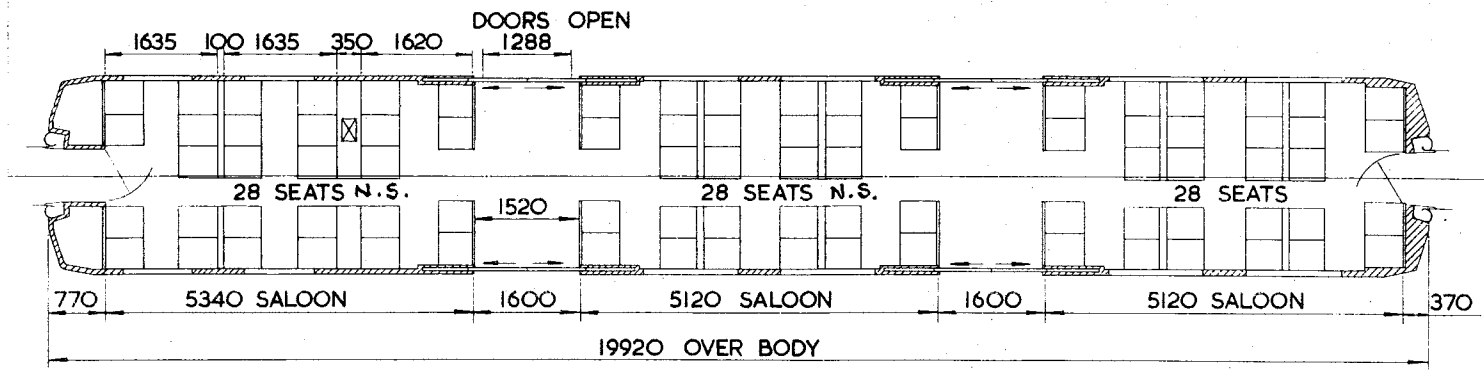
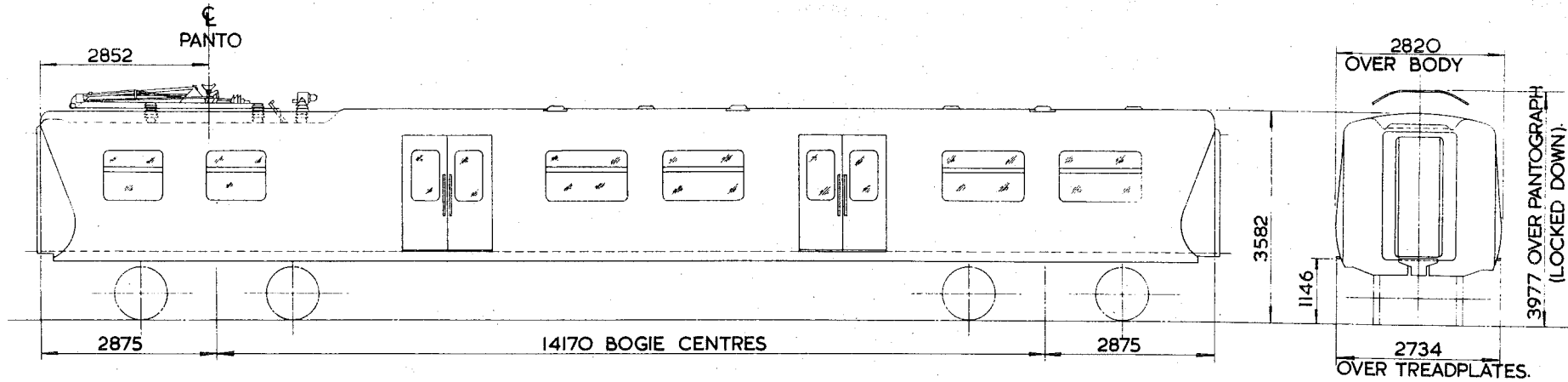

SEATS	84
TOILETS	-
COMPARTMENTS	-
GUARDS COMPARTMENTS	-
VENTILATION	-
CATERING EQUIPMENT	-

ORIGINAL DIAGRAMS FOR REFERENCE:-
BR 477

ISSUE	DATE
4	MAR 87

EH 210

BRAKES
BOGIE/SUSPENSION
BODY CONSTRUCTION
COUPLINGS
TRAIN HEATING
MAX. SPEED M.P.H.
MIN. RAD. CURVE CHAINS
LIGHTING
TARE WEIGHT TONNES
GANGWAYS
TRAIN COMMUNICATION
BUFFERS

BASIC TYPE

ELECTRO PNEUMATIC
BX1/Ta & BX1/Tb (ONE OF EACH)
STEEL UNDERFRAME & BODY FRAMING-ALUMINIUM BODY & ROOF
BAR
WASTE HEAT RECOVERY-DUCTED WARM AIR
75
3,5
FLUORESCENT
31
FLEXIBLE DIAPHRAGM/RIGID (GRP)
PUBLIC ADDRESS
NOT FITTED

ALTERNATIVES

TRACTION DATA FOR MULTIPLE UNITS

EMU- GREAT NORTHERN INNER SUBURBAN. INTRODUCED 1976.
VOLTAGE 25 KV A.C. OVERHEAD & 750 VOLTS D.C. THIRD RAIL

BASIC TYPE

EH 210 OA

VARIANTS

NONE

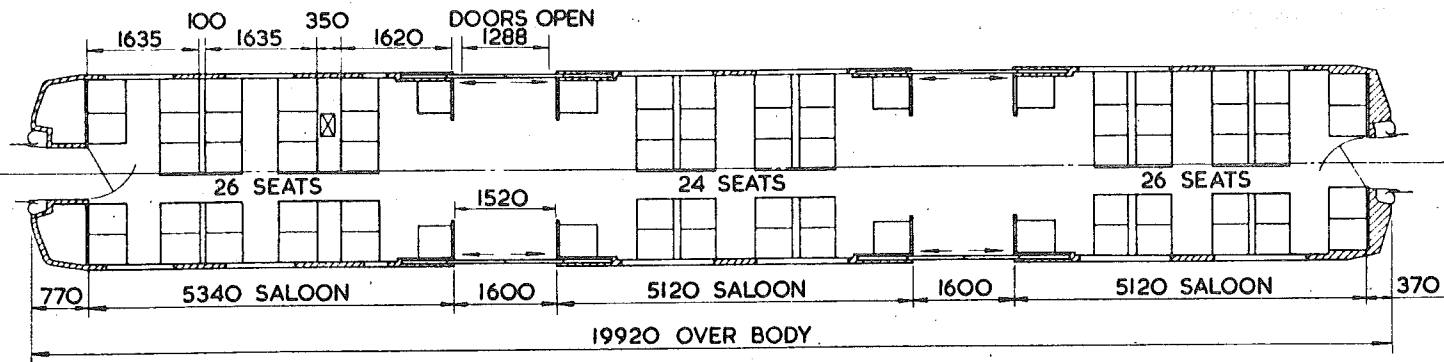
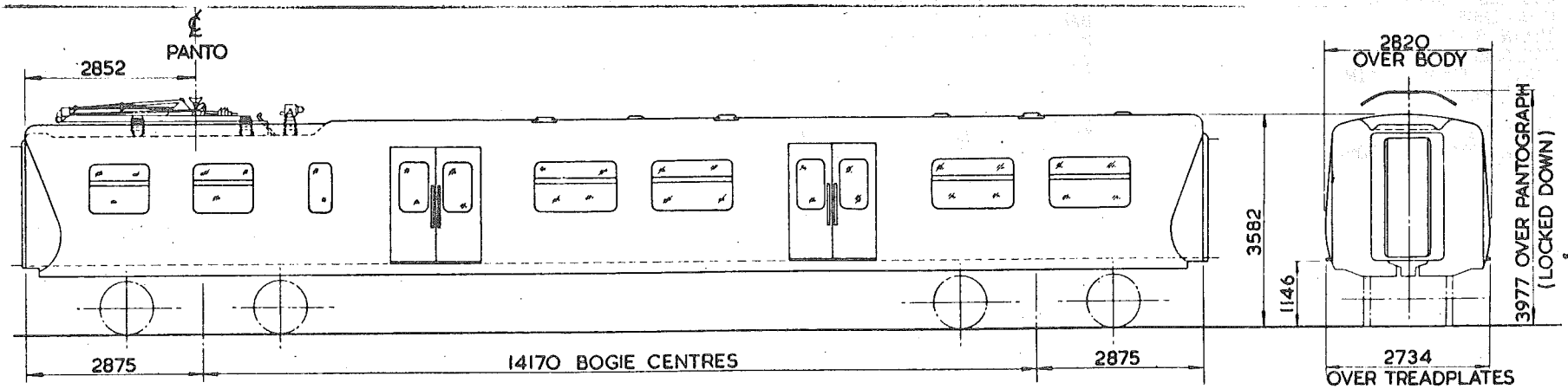

- SEATS 76
- TOILETS -
- COMPARTMENTS -
- GUARDS COMPARTMENTS -
- VENTILATION -
- CATERING EQUIPMENT -

ORIGINAL DIAGRAMS FOR REFERENCE.-
BR 479

ISSUE 3 DATE AUG '82

EH 211

BASIC TYPE

BRAKES
BOGIE/SUSPENSION
BODY CONSTRUCTION
COUPLINGS
TRAIN HEATING
MAX. SPEED M.P.H.
MIN. RAD. CURVE CHAINS
LIGHTING
TARE WEIGHT TONNES
GANGWAYS
TRAIN COMMUNICATION
BUFFERS

ELECTRO PNEUMATIC
BX1. T_e & BX1/Tf (ONE OF EACH)
STEEL UNDERFRAME & BODY FRAMING, ALUMINIUM BODY & ROOF
BAR
ELECTRIC-DUCTED WARM AIR
70
3.5
FLUORESCENT
33
FLEXIBLE DIAPHRAGH/RIGID (GRP)
PUBLIC ADDRESS
NOT FITTED

ALTERNATIVES

TRACTION DATA FOR MULTIPLE UNITS

EMU- GLASGOW AREA INTRODUCED 1979.
VOLTAGE 25 & 6.25 KV A.C. OVERHEAD

BASIC TYPE

EH 211 0A

VARIANTS

NONE

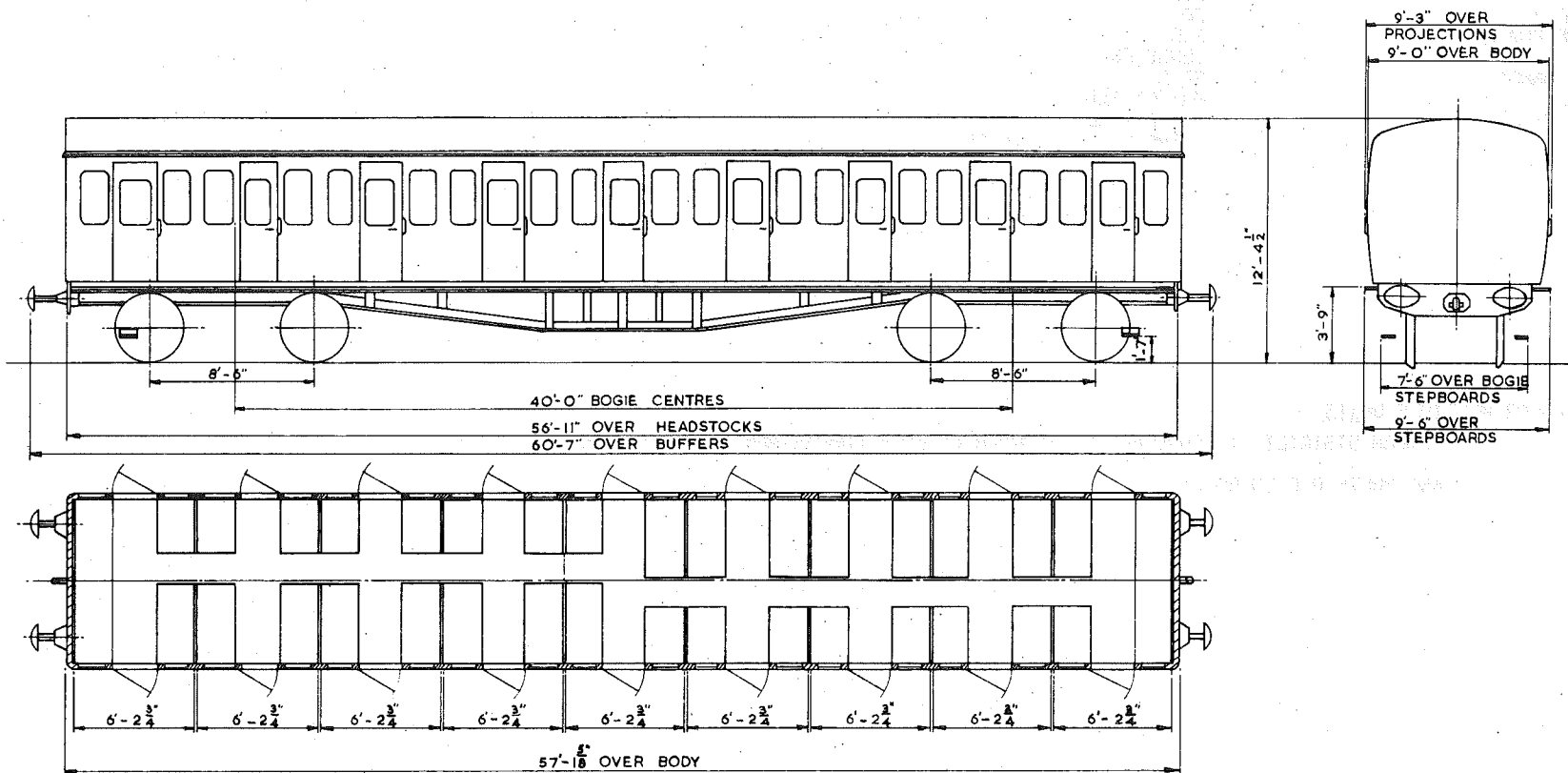

SEATS	92
TOILETS	-
COMPARTMENTS	-
GUARDS COMPARTMENTS	-
VENTILATION	-
CATERING EQUIPMENT	-

ORIGINAL DIAGRAMS FOR REFERENCE.-
BR 476

ISSUE DATE
2 MAY '81

EH 213

BASIC TYPE

ALTERNATIVES

BRAKES
BOGIE/SUSPENSION
BODY CONSTRUCTION
COUPLINGS
TRAIN HEATING
MAX. SPEED M. P. H.
MIN. RAD. CURVE CHAINS
LIGHTING
TARE WEIGHT TONNES
GANGWAYS
TRAIN COMMUNICATION
BUFFERS

ELECTRO PNEUMATIC
CLASS 501 TRAILER
STEEL
SCREW
ELECTRIC (BR)
70
3.5
TUNGSTEN
29.5
NOT FITTED
NOT FITTED
SPINDLE-559 X 114 OVAL

TRACTION DATA FOR MULTIPLE UNITS

EMU- LONDON DISTRICT INTRODUCED 1957 CONVERTED FROM COMPARTMENTS TO OPEN 1975.
VOLTAGE 630 VOLTS D.C. THIRD RAIL

BASIC TYPE

EH 213 0A

VARIANTS

NONE

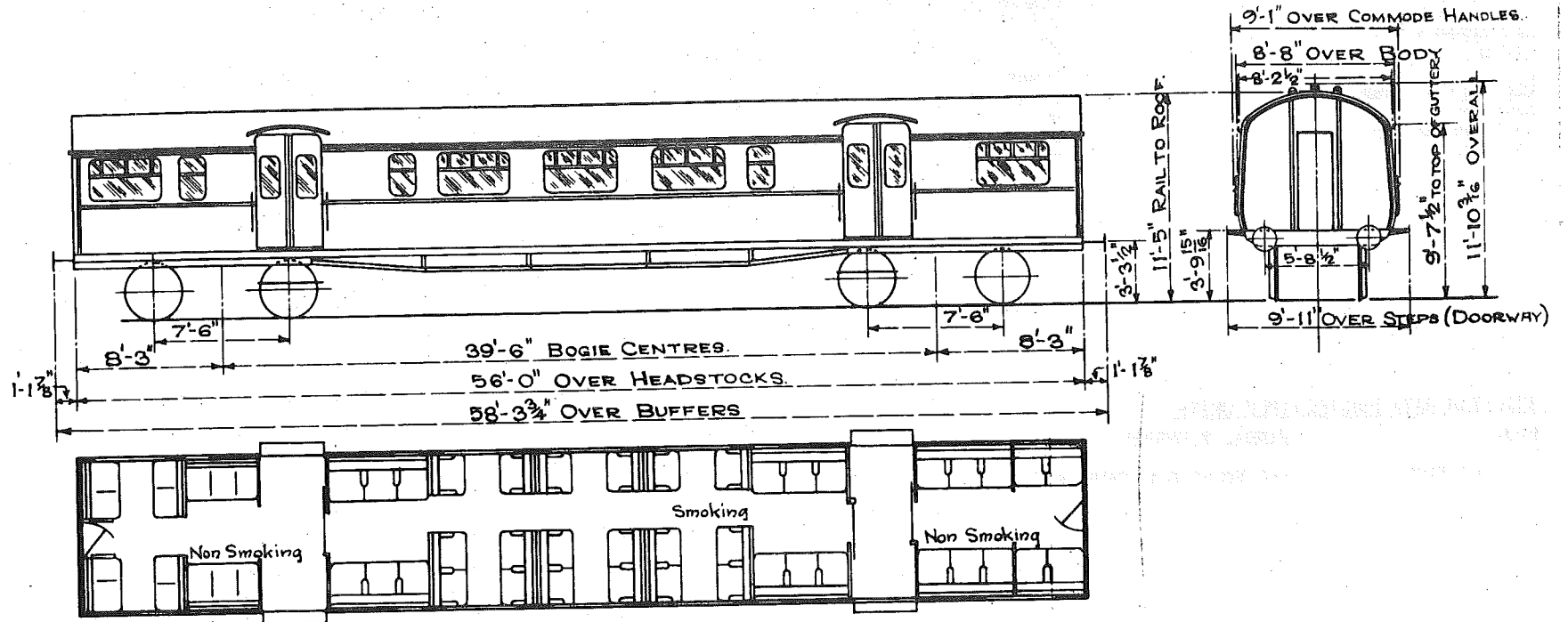

SEATS	54
TOILETS	-
COMPARTMENTS	-
GUARDS COMPARTMENTS	-
VENTILATION	-
CATERING EQUIPMENT	-

ORIGINAL DIAGRAMS FOR REFERENCE.-
LMS 368A

ISSUE 2 DATE AUG 81

EH 214

BRAKES
BOGIE/SUSPENSION
BODY CONSTRUCTION
COUPLINGS
TRAIN HEATING
MAX. SPEED M. P. H.
MIN. RAD. CURVE CHAINS
LIGHTING
TARE WEIGHT TONNES
GANGWAYS
TRAIN COMMUNICATION
BUFFERS

BASIC TYPE

ELECTRO PNEUMATIC
CLASS 503 TRAILER
STEEL
PERMANENT SCREW
ELECTRIC (ØR)
65
3.5
TUNGSTEN
21.5
NOT FITTED
NOT FITTED
SPINDLE-457 DIA.

ALTERNATIVES

TRACTION DATA FOR MULTIPLE UNITS

EMU- WIRRAL & MERSEY. INTRODUCED 1938 & 1956.
VOLTAGE 650 VOLTS D.C. THIRD RAIL

BASIC TYPE

EH 214 0A

VARIANTS

NONE

TRAILER SECOND

CLASS 315

TS

EH 216

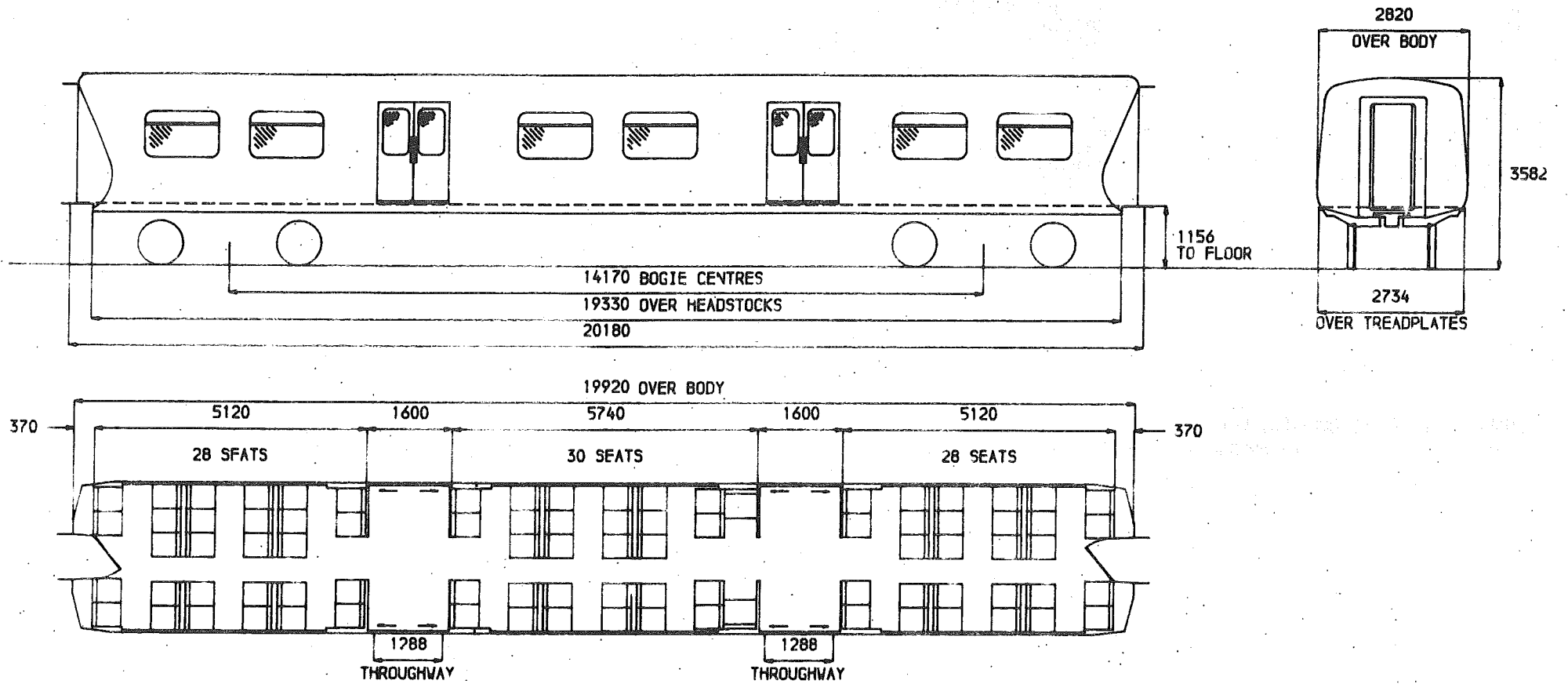

VEHICLE NOS 71281-71321 ORIGINALLY FITTED WITH BRUSH ELECTRICAL EQUIPMENT
 VEHICLE NOS 71322-71341 ORIGINALLY FITTED WITH GEC ELECTRICAL EQUIPMENT

SEATS	86
TOILETS	-
COMPARTMENTS	-
GUARDS COMPARTMENTS	-
VENTILATION	-
CATFRING EQUIPMENT	-

ORIGINAL DIAGRAMS FOR REFERENCE,-
BR 468

ISSUE	DATE
4	AUG' 82

EH 216

BASIC TYPE

BRAKES
BOGIE/SUSPENSION
BODY CONSTRUCTION
COUPLINGS
TRAIN HEATING
MAX. SPEED M.P.H.
MIN. RAD. CURVE CHAINS
LIGHTING
TARE WEIGHT TONNES
GANGWAYS
TRAIN COMMUNICATION
BUFFERS

ELECTRO PNEUMATIC
BX1/Tc
STEEL UNDERFRAME & BODY FRAMING-ALUMINIUM BODY & ROOF
BAR
ELECTRIC-DUCTED WARM AIR
75
3.5
FLUORESCENT
25.5
FLEXIBLE DIAPHRAGM/RIGID (GRP)
PUBLIC ADDRESS
NOT FITTED

ALTERNATIVES

TRACTION DATA FOR MULTIPLE UNITS

EMU- LIVERPOOL ST.-SHENFIELD INNER SUBURBAN
VOLTAGE 25 KV A.C.OVERHEAD

BASIC TYPE

EH 216 0A

VARIANTS

NONE

TRAILER SECOND

CLASS 315

TS

EH 217

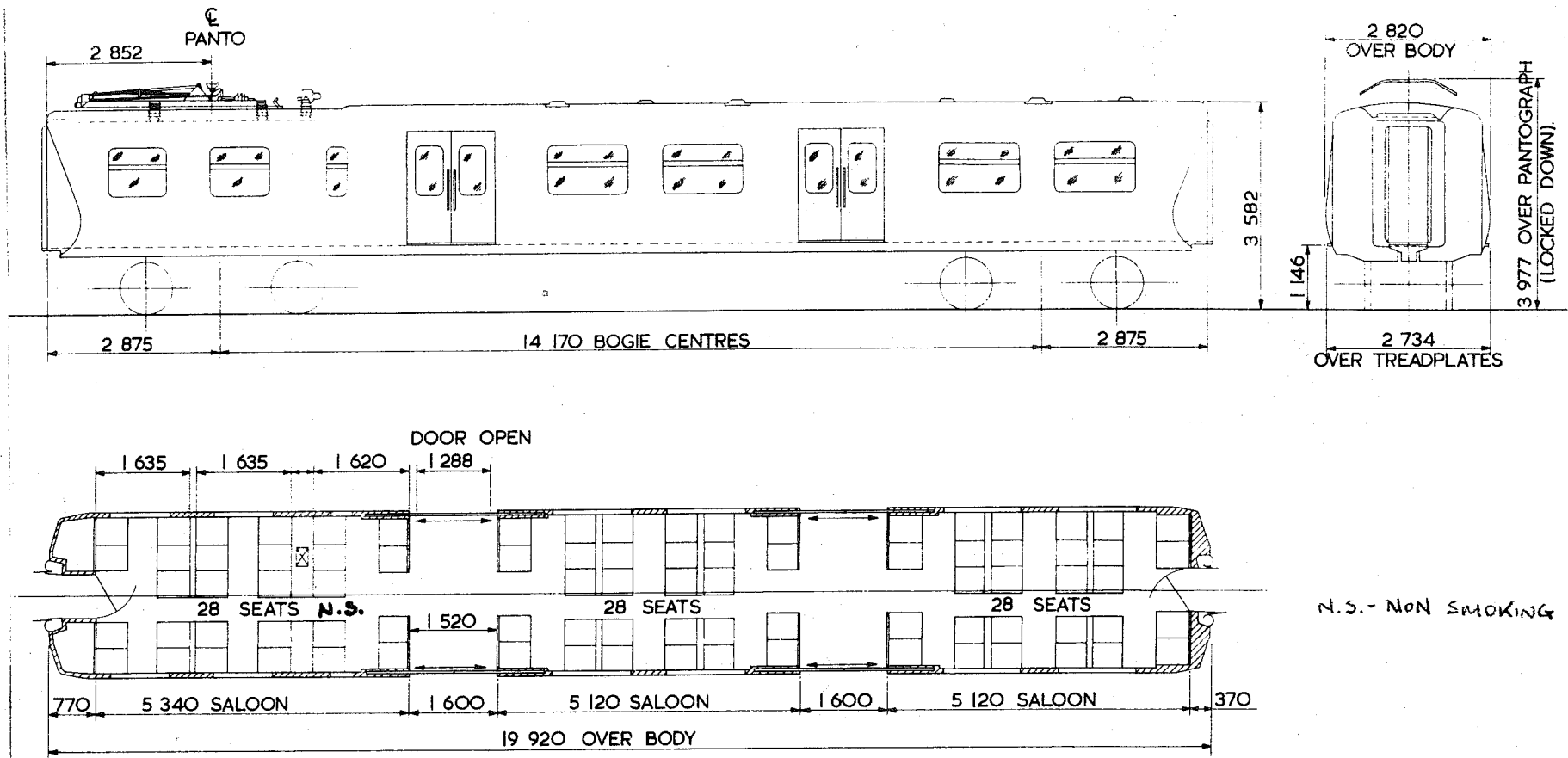

N.S. - NON SMOKING

SEATS	84
TOILETS	-
COMPARTMENTS	-
GUARDS COMPARTMENTS	-
VENTILATION	-
CATERING EQUIPMENT	-

ORIGINAL DIAGRAMS FOR REFERENCE:-
BR 467

ISSUE DATE
4 MAR 87

EH 217

BASIC TYPE

ALTERNATIVES

BRAKES
BOGIE/SUSPENSION
BODY CONSTRUCTION
COUPLINGS
TRAIN HEATING
MAX. SPEED M.P.H.
MIN. RAD. CURVE CHAINS
LIGHTING
TARE WEIGHT TONNES
GANGWAYS
TRAIN COMMUNICATION
BUFFERS

ELECTRO PNEUMATIC
BX1/Te & BX1/Tf (ONE OF EACH)
STEEL UNDERFRAME & BODY FRAMING-ALUMINIUM BODY & ROOF
BAR
ELECTRIC-DUCTED WARM AIR
75
3.5
FLUORESCENT
32
FLEXIBLE DIAPHRAGM/RIGID(GRP)
PUBLIC ADDRESS
NOT FITTED

TRACTION DATA FOR MULTIPLE UNITS

EMU- LIVERPOOL ST.-SHENFIELD INNER SUBURBAN
VOLTAGE 25 KV A.C.OVERHEAD
EQUIPPED WITH PANTORAPH & TRANSFORMER

BASIC TYPE

EH 217 OA

VARIANTS

NONE

TRAILER SECOND

CLASS 508

TS

EH 218

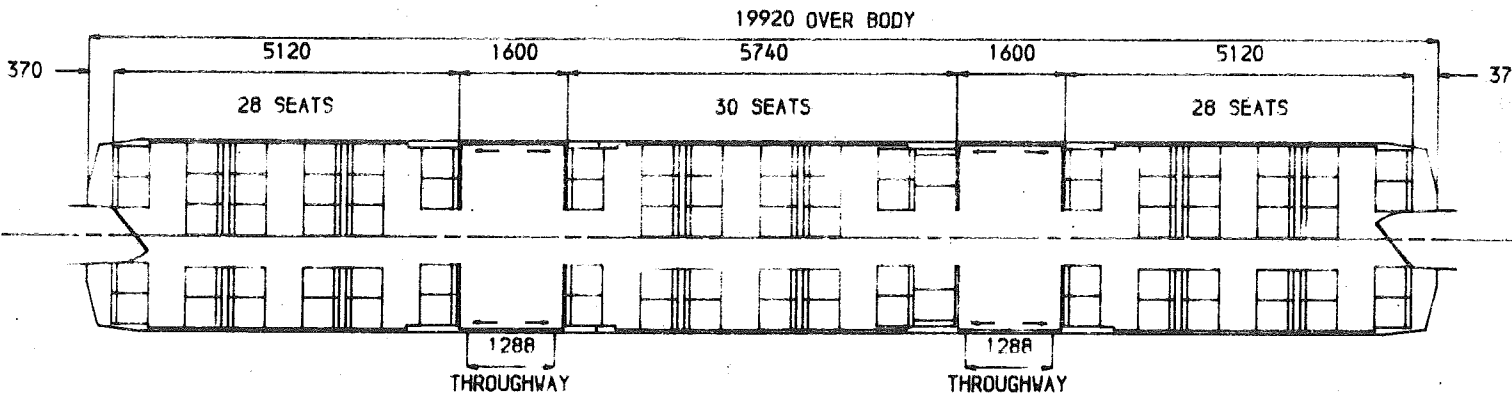
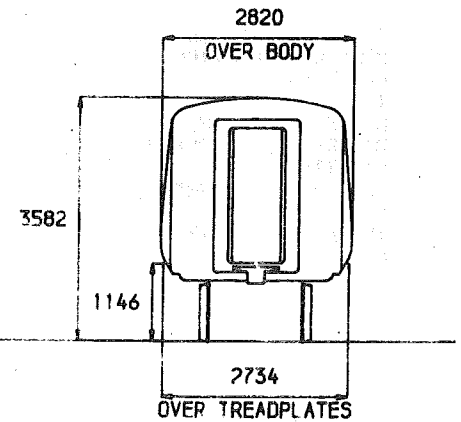
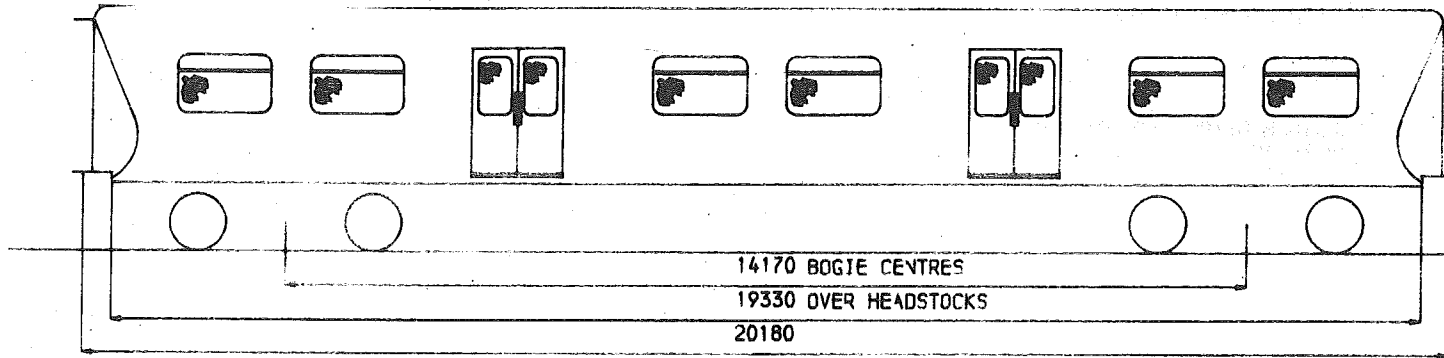

SEATS	86
TOILETS	-
COMPARTMENTS	-
GUARDS COMPARTMENTS	-
VENTILATION	-
CATERING EQUIPMENT	-

ISSUE 3 DATE AUG' 82

EH 218

BRAKES
BOGIE/SUSPENSION
BODY CONSTRUCTION
COUPLINGS
TRAIN HEATING
MAX. SPEED M.P.H.
MIN. RAD. CURVE CHAINS
LIGHTING
TARE WEIGHT TONNES
GANGWAYS
TRAIN COMMUNICATION
BUFFERS

BASIC TYPE

ELECTRO PNEUMATIC
BX1/TJ
STEEL UNDERFRAME & BODY FRAMING--ALUMINIUM BODY & ROOF
BAR
ELECTRIC-DUCTED WARM AIR
75
3.5
FLUORESCENT
26.5
FLEXIBLE DIAPHRAM/RIGID (GRP)
PUBLIC ADDRESS
NOT FITTED

ALTERNATIVES

TRACTION DATA FOR MULTIPLE UNITS

EMU- INTRODUCED 1980.
VOLTAGE 750/850 VOLTS D.C. THIRD RAIL

BASIC TYPE

EH 218 0A

VARIANTS

NONE

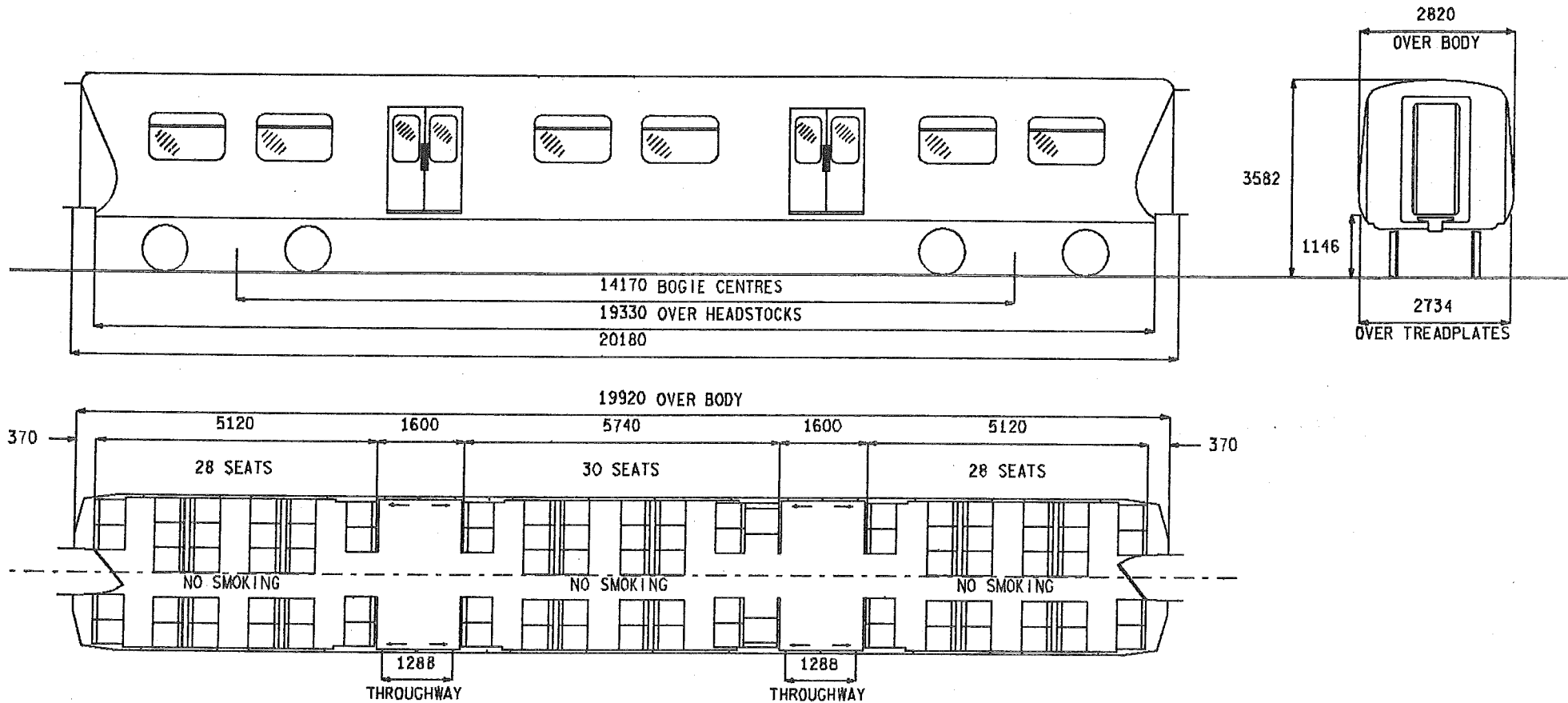

SEATS	86
TOILETS	-
COMPARTMENTS	-
GUARDS COMPARTMENTS	-
VENTILATION	-
CATERING EQUIPMENT	-

ISSUE 4 DATE APR '83

EH 219

BASIC TYPE

BRAKES
BOGIE/SUSPENSION
BODY CONSTRUCTION
COUPLINGS
TRAIN HEATING
MAX.SPEED M.P.H.
MIN.RAD.CURVE CHAINS
LIGHTING
TARE WEIGHT TONNES
GANGWAYS
TRAIN COMMUNICATION
BUFFERS

ELECTRO PNEUMATIC
BX1/TJ
STEEL UNDERFRAME & BODY FRAMING,ALUMINIUM BODY & ROOF
BAR
ELECTRIC-DUCTED WARM AIR
75
3.5
FLUORESCENT
25.5
FLEXIBLE DIAPHRAGM/RIGID(GRP)
PUBLIC ADDRESS
NOT FITTED

ALTERNATIVES

AUTOMATIC SOLID SHANK(BUCKEYE)

TRACTION DATA FOR MULTIPLE UNITS

EMU- INTRODUCED 1980.
VOLTAGE 750/850 VOLTS D.C.THIRD RAIL

BASIC TYPE

EH 219 0A

VARIANTS

1B AUTOMATIC SOLID SHANK(BUCKEYE)COUPLINGS.

TRAILER SECOND

CLASS 455

TS

EH 221

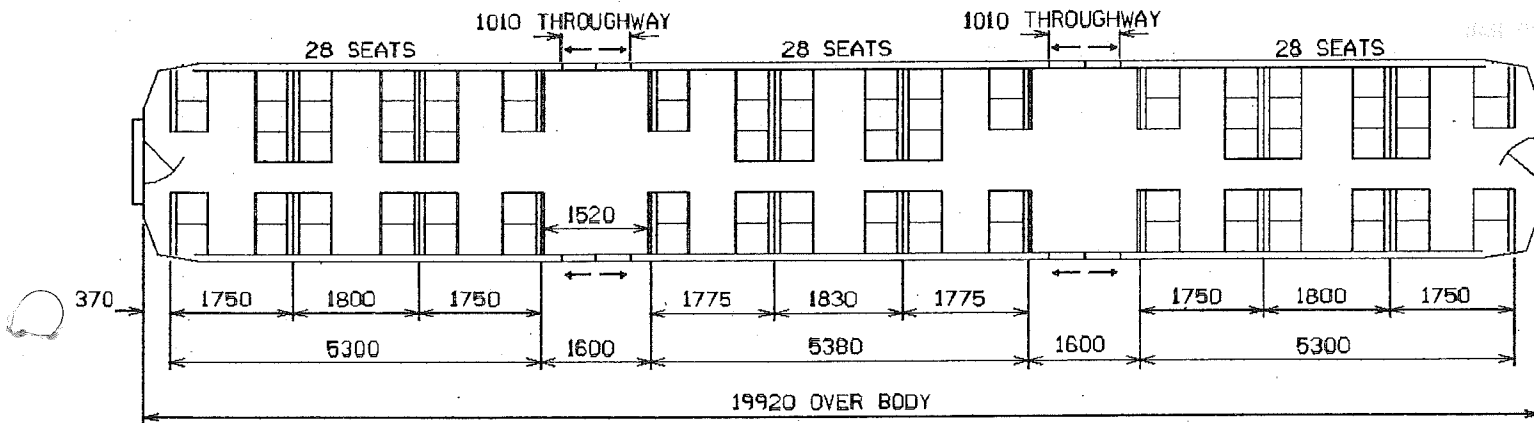
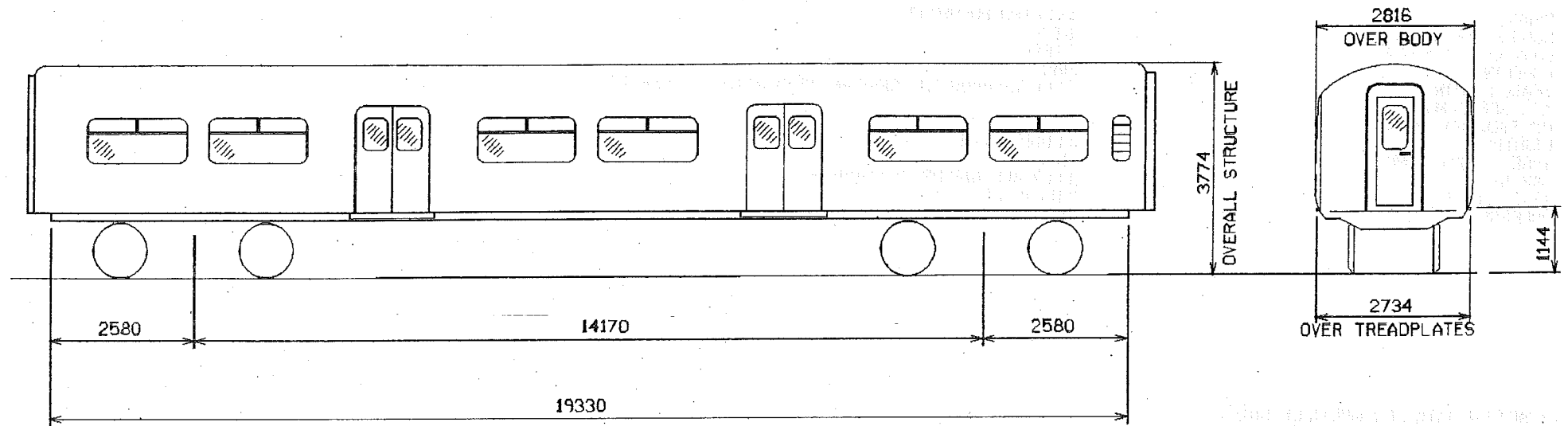

- SEATS 84
- TOILETS -
- COMPARTMENTS -
- GUARDS COMPARTMENTS -
- VENTILATION -
- CATERING EQUIPMENT -

ISSUE 2
DATE DEC'82

EH 221

BRAKES
BOGIE/SUSPENSION
BODY CONSTRUCTION
COUPLINGS
TRAIN HEATING
MAX SPEED M.P.H.
MIN.RAD.CURVE CHAINS
LIGHTING
TARE WEIGHT TONNES
GANGWAYS
TRAIN COMMUNICATION
BUFFERS

BASIC TYPE

ELECTRO-PNEUMATIC
BT13c
STEEL
BAR
ELECTRIC(BR)WITH PRESSURE VENTILATION & HEATING
75
3.5
FLUORESCENT
27.1
FLEXIBLE DIAPHRAGM/RIGID(GRP)
PUBLIC ADDRESS
NOT FITTED

ALTERNATIVES

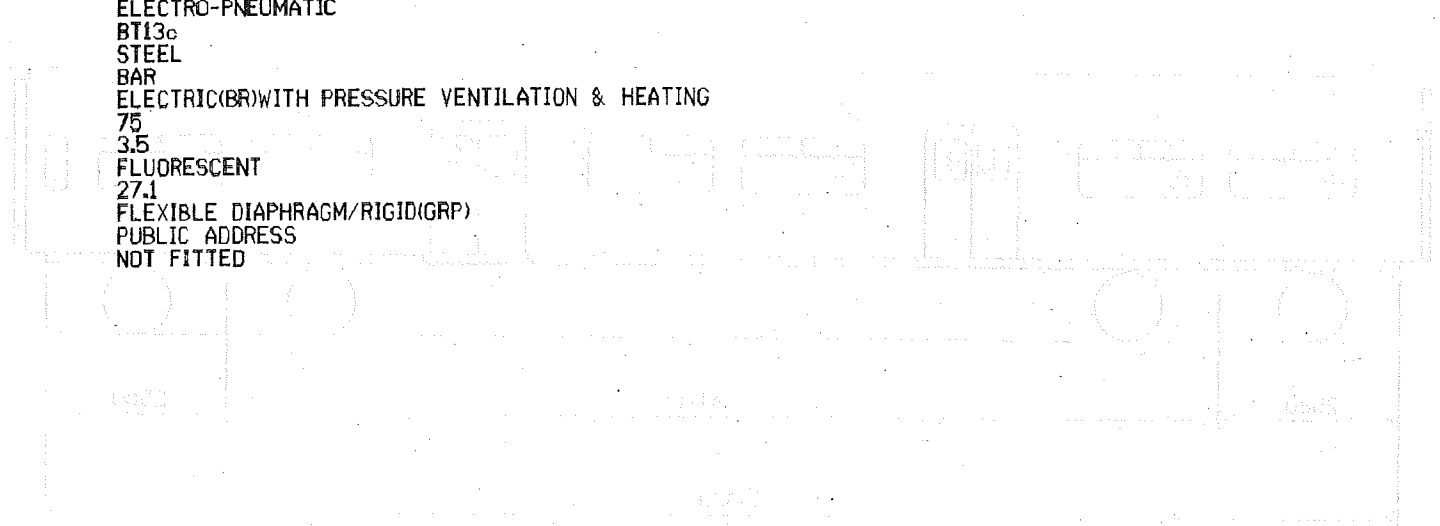

TRACTION DATA FOR MULTIPLE UNITS

EMU- SOUTHERN REGION ROUTES. INTRODUCED 1982.
VOLTAGE 750 VOLTS D.C.THIRD RAIL

BASIC TYPE

EH 221 0A

VARIANTS

NONE

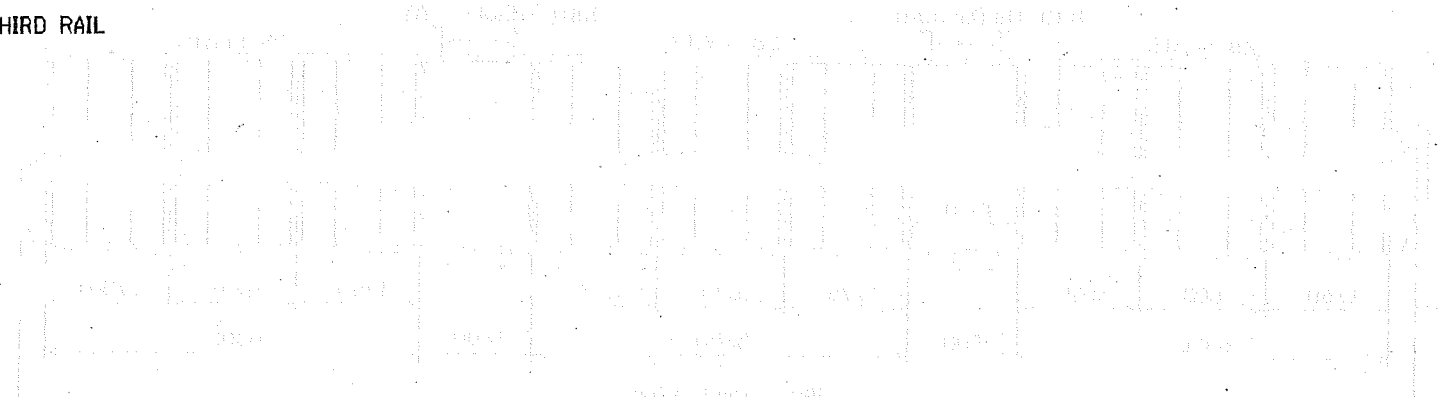

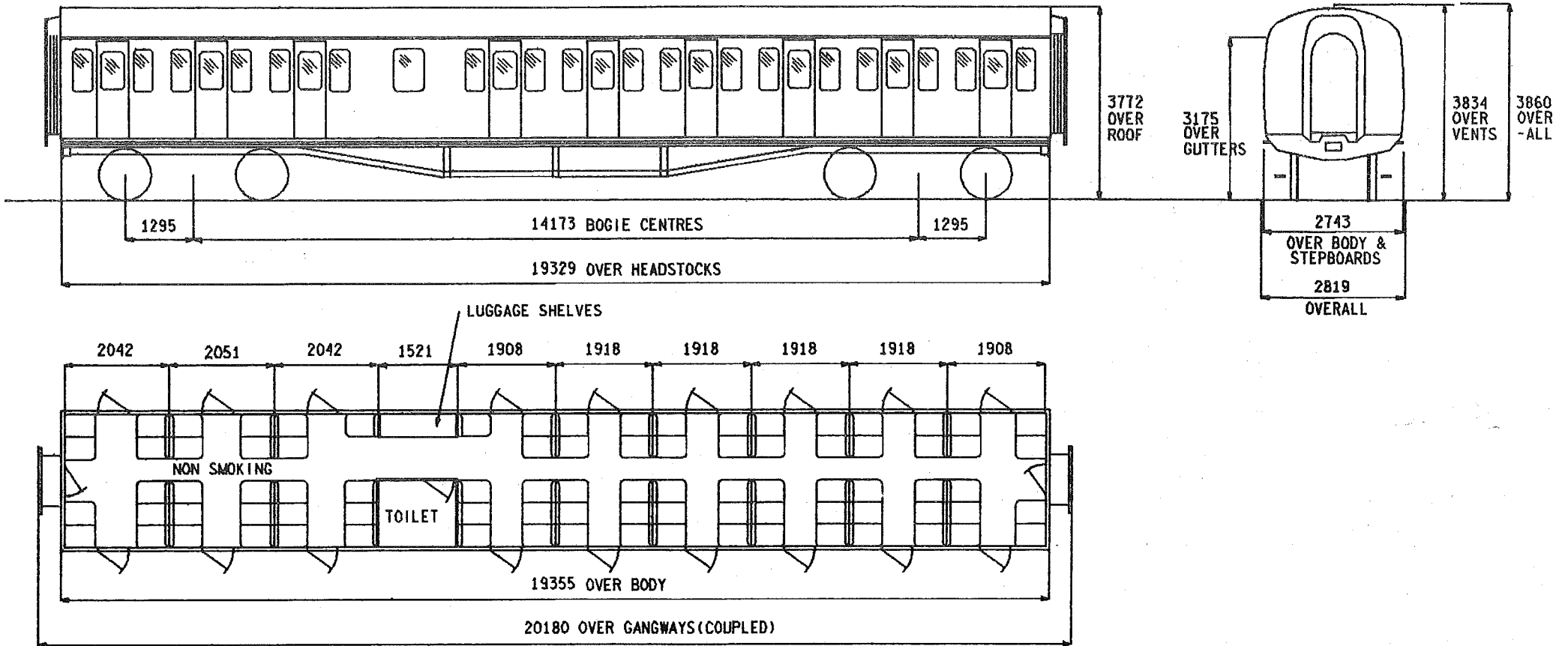

SEATS	86
TOILETS	1
COMPARTMENTS	-
GUARDS COMPARTMENTS	-
VENTILATION	-
CATERING EQUIPMENT	-

ISSUE 5 DATE NOV 87

EH 222

BASIC TYPE

BRAKES
BOGIE/SUSPENSION
BODY CONSTRUCTION
COUPLINGS
TRAIN HEATING
MAX.SPEED M.P.H.
MIN.RAD.CURVE CHAINS
LIGHTING
TARE WEIGHT TONNES
GANGWAYS
A.W.S.
TRAIN COMMUNICATION
BUFFERS

ELECTRO PNEUMATIC
GRESLEY ET7
STEEL
AUTOMATIC SOLID SHANK(BUCKEYE)
ELECTRIC(BR)
75
3.5
FLUORESCENT
31
PULLMAN WITH RIGID(GRP)INNER PANELS
FITTED
PUBLIC ADDRESS
CENTRE

ALTERNATIVES

B4

TRACTION DATA FOR MULTIPLE UNITS

GREAT EASTERN OUTER SUBURBAN. INTRODUCED 1956 FOR D.C.WORKING,REBUILT 1962 FOR A.C.WORKING,REFURBISHED 1981.
25 & 6.25 KV A.C.OVERHEAD

BASIC TYPE

EH 222 0A

VARIANTS

OB B4 BOGIES.

TRAILER STANDARD

CLASS 302
305/2
308/1

TS

EH 223

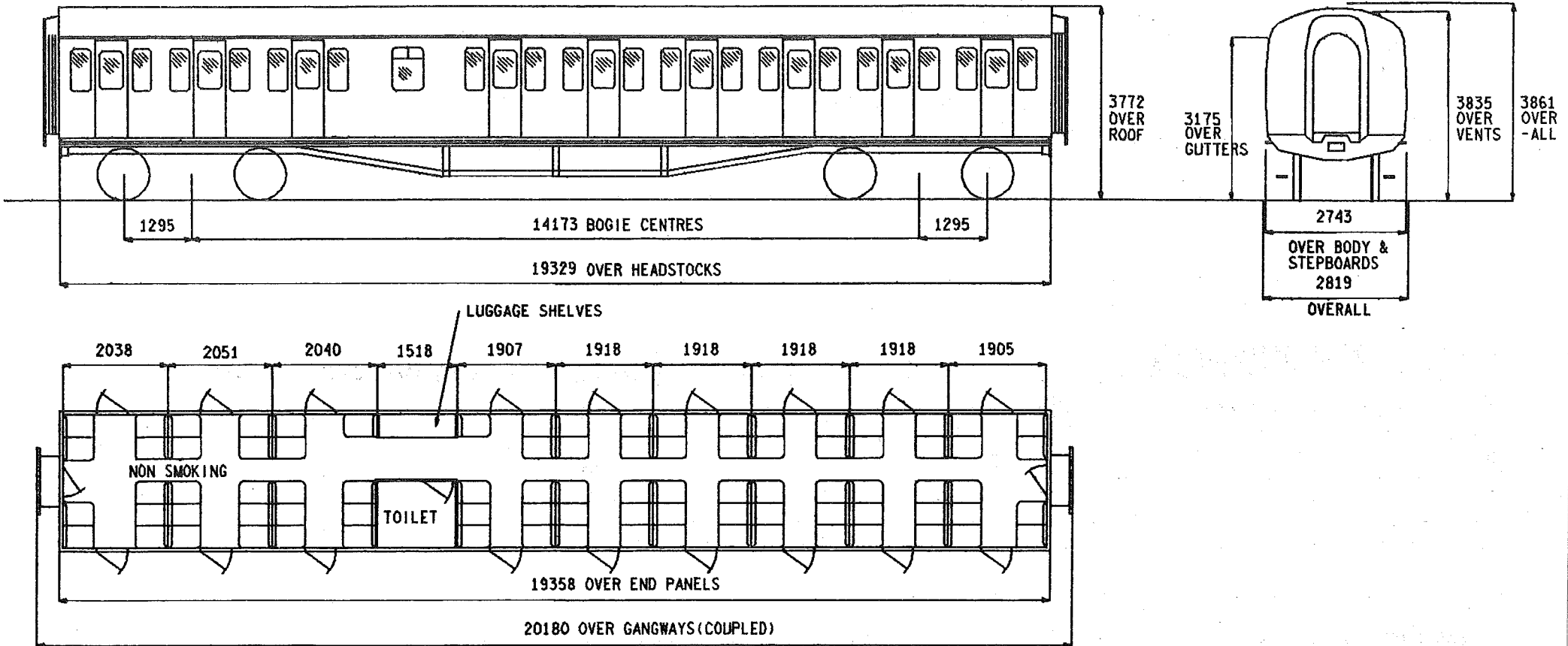

SEATS	86
TOILETS	1
COMPARTMENTS	-
GUARDS COMPARTMENTS	-
VENTILATION	-
CATERING EQUIPMENT	-

ISSUE 4 DATE NOV 87

EH 223

BRAKES
BOGIE/SUSPENSION
BODY CONSTRUCTION
COUPLINGS
TRAIN HEATING
MAX.SPEED M.P.H.
MIN.RAD.CURVE CHAINS
LIGHTING
TARE WEIGHT TONNES
GANGWAYS
TRAIN COMMUNICATION
BUFFERS

BASIC TYPE

ELECTRO PNEUMATIC
GRESLEY ET5
STEEL
AUTOMATIC SOLID SHANK (ALLIANCE NO 2)
ELECTRIC (BR)
75
3.5
FLUORESCENT
30 (EST)
PULLMAN WITH RIGID (GRP) INNER PANELS
PUBLIC ADDRESS
CENTRE

ALTERNATIVES

GRESLEY ET8, GRESLEY ET2, B4, B5

TRACTION DATA FOR MULTIPLE UNITS

EMU- GREAT EASTERN OUTER SUBURBAN. INTRODUCED CLASS 302 1958, CLASS 305/2 1960 & CLASS 308/1 1961. REFURBISHED 1983.
VOLTAGE 25 & 6.25 KV A.C. OVERHEAD

BASIC TYPE

EH 223 OA-REFURBISHED

VARIANTS

OB CLASS 308/1 GRESLEY ET8 BOGIES.
OC CLASS 302 GRESLEY ET2 BOGIES.
OD CLASS 302 B4 BOGIES.
OE CLASS 302 B5 BOGIES.

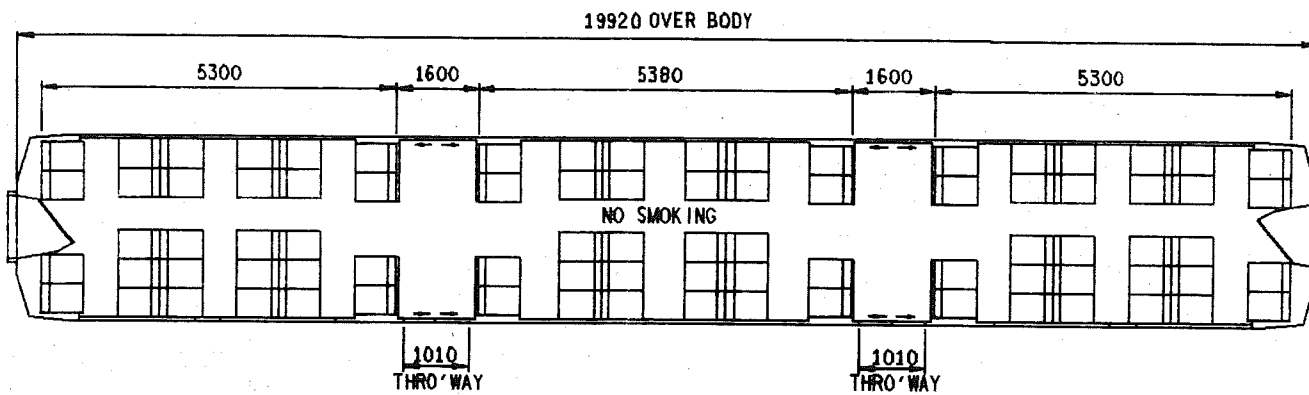
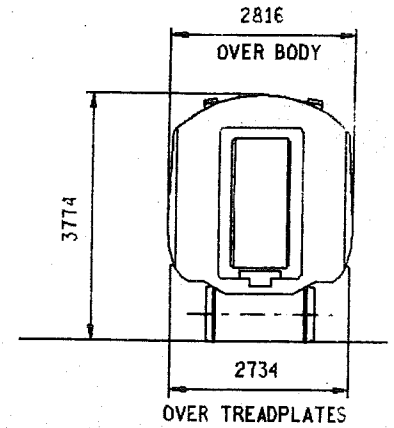
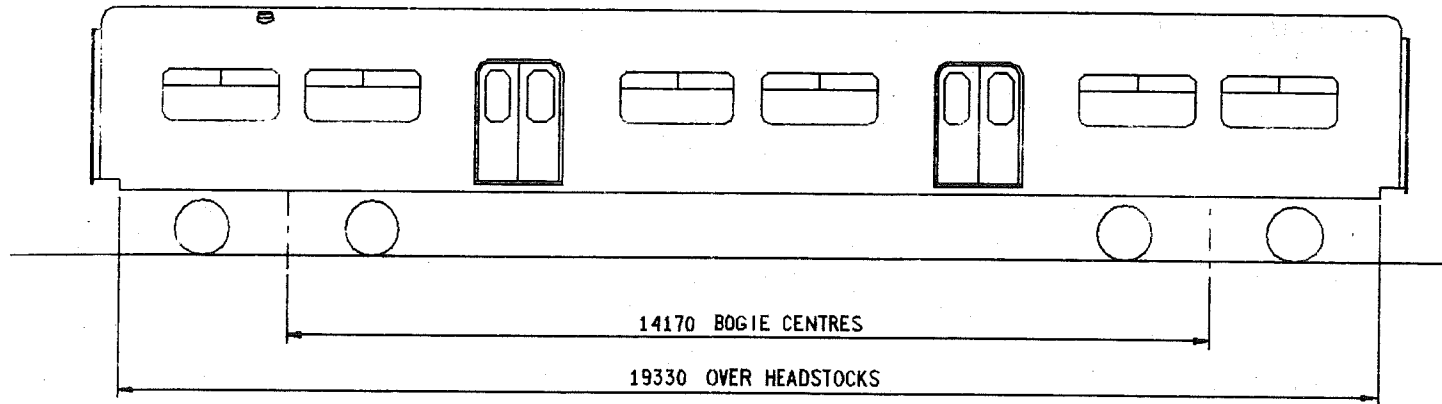

- SEATS 84
- TOILETS -
- COMPARTMENTS -
- GUARDS COMPARTMENTS -
- VENTILATION -
- CATERING EQUIPMENT -

ISSUE 1 DATE AUG 85

EH 224

BASIC TYPE

ALTERNATIVES

BRAKES
BOGIE/SUSPENSION
BODY CONSTRUCTION
COUPLINGS
TRAIN HEATING
MAX. SPEED M.P.H.
MIN. RAD. CURVE CHAINS
LIGHTING
TARE WEIGHT TONNES
GANGWAYS
TRAIN COMMUNICATION
BUFFERS

ELECTRO-PNEUMATIC
BT13c
STEEL
BAR
ELECTRIC (BR)
75
3.5
FLUORESCENT
27.1
FLEXIBLE DIAPHRAGM/RIGID (GRP)
PUBLIC ADDRESS
NOT FITTED

TRACTION DATA FOR MULTIPLE UNITS

EMU- SOUTHERN REGION ROUTES. INTRODUCED 1985
VOLTAGE 750 VOLTS D.C. THIRD RAIL

BASIC TYPE

EH 224 0A

VARIANTS

NONE

TRAILER SECOND

CLASS 304/1

TS

EH 225

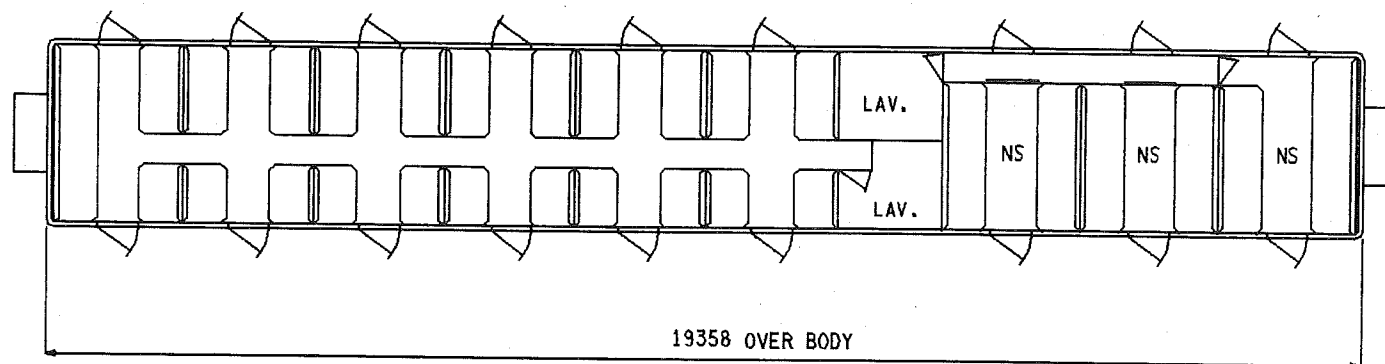
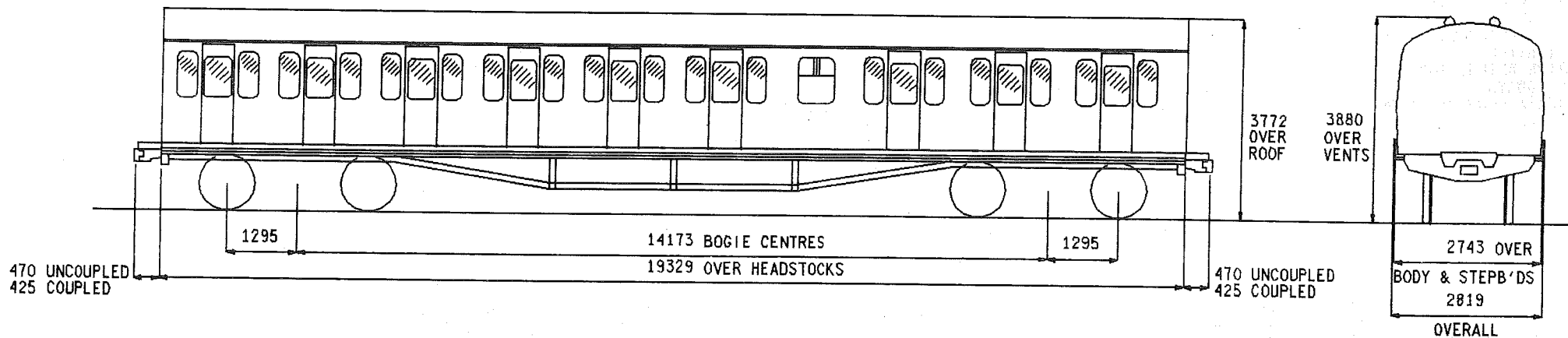

NS=NON SMOKING

SEATS	86
TOILETS	2
COMPARTMENTS	3 PLUS 1 SALOON
GUARDS COMPARTMENTS	-
VENTILATION	-
CATERING EQUIPMENT	-

ORIGINAL DIAGRAMS FOR REFERENCE:-
BR 456

ISSUE	DATE
1	MAR'85

EH 225

BRAKES
BOGIE/SUSPENSION
BODY CONSTRUCTION
COUPLINGS
TRAIN HEATING
MAX.SPEED M.P.H.
MIN.RAD.CURVE CHAINS
LIGHTING
TARE WEIGHT TONNES
GANGWAYS
TRAIN COMMUNICATION
BUFFERS

BASIC TYPE

ELECTRO PNEUMATIC
GRESLEY ET8
STEEL
AUTOMATIC SOLID SHANK (ALLIANCE NO.2)
ELECTRIC (BR)
75
3.5
TUNGSTEN
31.5
NOT FITTED
NOT FITTED
NOT FITTED

ALTERNATIVES

TRACTION DATA FOR MULTIPLE UNITS

EMU- EUSTON-BIRMINGHAM-MANCHESTER & LIVERPOOL. INTRODUCED 1960.
VOLTAGE 25 KV A.C.OVERHEAD

BASIC TYPE

EH 225 0A

VARIANTS

NONE

TRAILER SECOND

CLASS 304/2
304/3

TS

EH 226

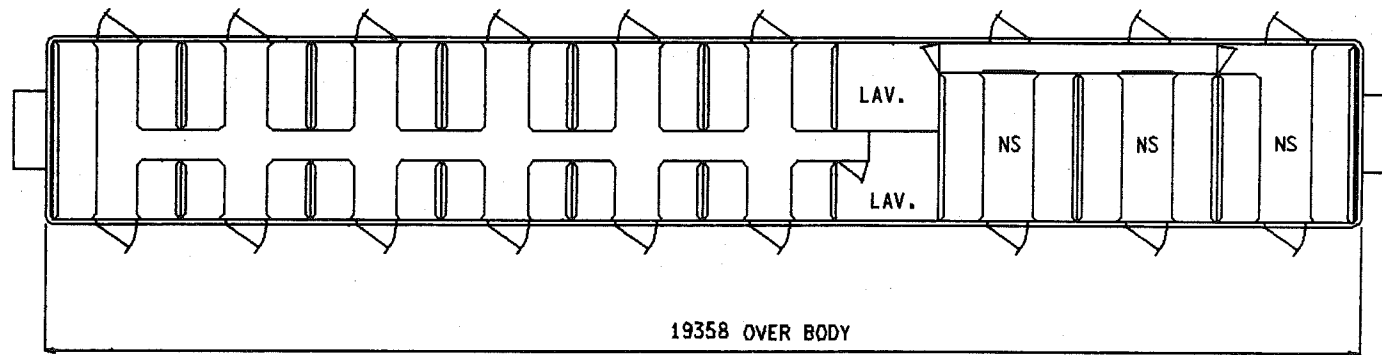
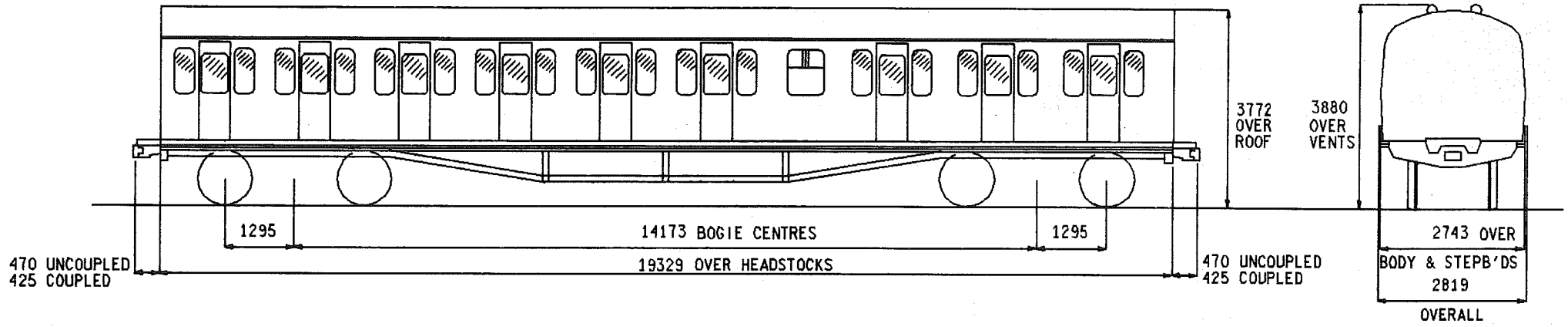

NS=NON SMOKING

SEATS	86
TOILETS	2
COMPARTMENTS	3 PLUS 1 SALOON
GUARDS COMPARTMENTS	-
VENTILATION	-
CATERING EQUIPMENT	-

ORIGINAL DIAGRAMS FOR REFERENCE:-
BR 457

ISSUE	DATE
1	MAR '85

EH 226

BRAKES
BOGIE/SUSPENSION
BODY CONSTRUCTION
COUPLINGS
TRAIN HEATING
MAX.SPEED M.P.H.
MIN.RAD.CURVE CHAINS
LIGHTING
TARE WEIGHT TONNES
GANGWAYS
TRAIN COMMUNICATION
BUFFERS

BASIC TYPE

ELECTRO PNEUMATIC
GRESLEY ET8
STEEL
AUTOMATIC SOLID SHANK(ALLIANCE NO.2)
ELECTRIC(BR)
75
3.5
TUNGSTEN
32.5
NOT FITTED
NOT FITTED
NOT FITTED

ALTERNATIVES

TRACTION DATA FOR MULTIPLE UNITS

EMU- EUSTON-BIRMINGHAM-MANCHESTER & LIVERPOOL.INTRODUCED 1960.
VOLTAGE 25 KV A.C.OVERHEAD

BASIC TYPE

EH 226 0A

VARIANTS

NONE

TRAILER SECOND

CLASS 309/1

TS

EH 227

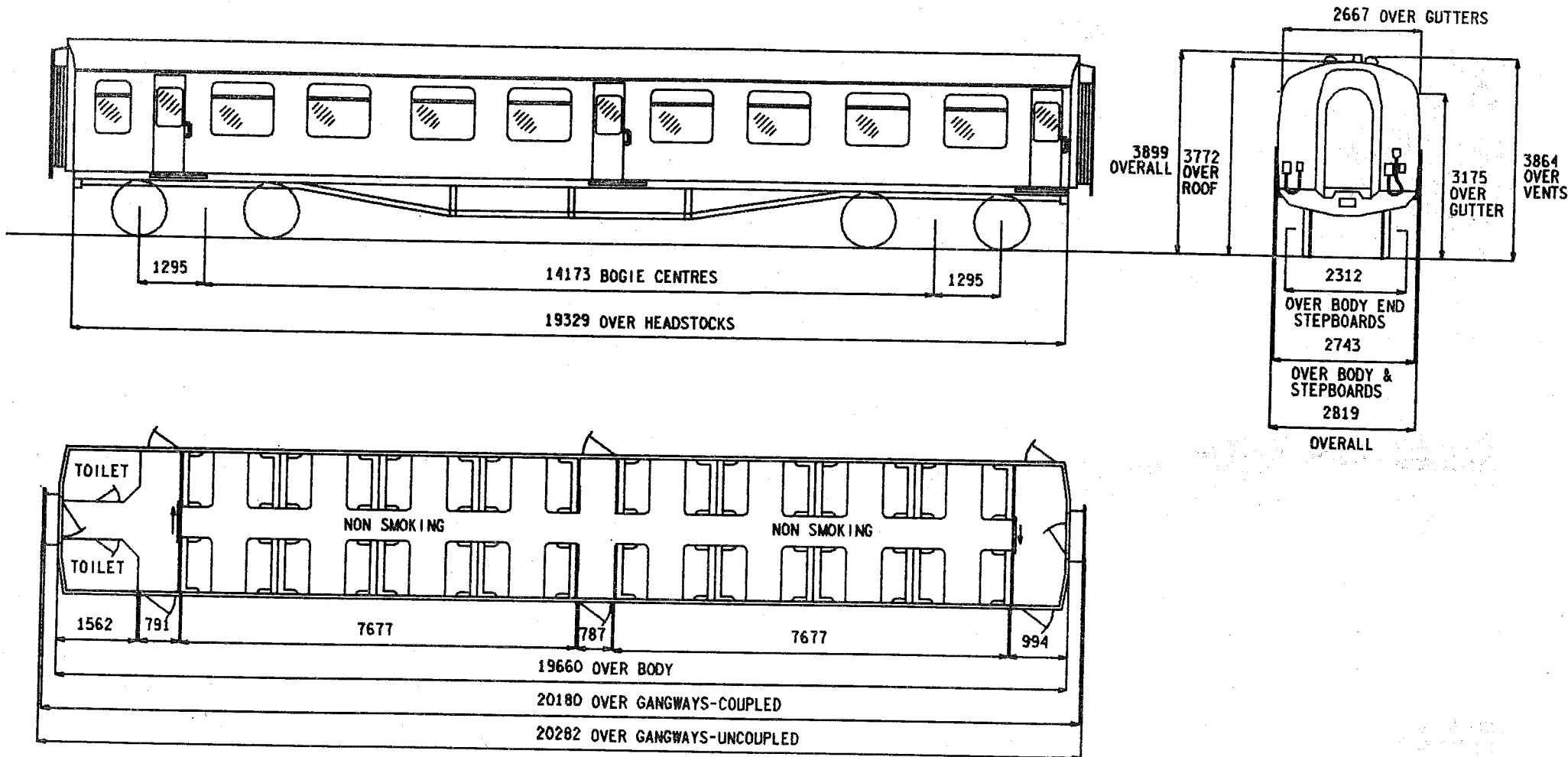

SEATS	64
TOILETS	2
COMPARTMENTS	-
GUARDS COMPARTMENTS	-
VENTILATION	-
CATERING EQUIPMENT	-

ISSUE 1 DATE OCT '86

EH 227

BRAKES
BOGIE/SUSPENSION
BODY CONSTRUCTION
COUPLINGS
TRAIN HEATING
MAX. SPEED M.P.H.
MIN. RAD. CURVE CHAINS
LIGHTING
TARE WEIGHT TONNES
GANGWAYS
TRAIN COMMUNICATION
BUFFERS

BASIC TYPE

ELECTRO PNEUMATIC
COMMONWEALTH
STEEL
AUTOMATIC SOLID SHANK (ALLIANCE NO. 2)
ELECTRIC (BR)
100
3.5
TUNGSTEN
35
PULLMAN
PUBLIC ADDRESS
NOT FITTED

ALTERNATIVES

TRACTION DATA FOR MULTIPLE UNITS

EMU- LIVERPOOL ST.-CLACTON & WALTON INTRODUCED 1962, REFURBISHED 1985.
VOLTAGE 25 & 6.25 KV A.C. OVERHEAD.

BASIC TYPE

EH 227 0A

VARIANTS

NONE

TRAILER SECOND

CLASS 309/2

TS

EH 228

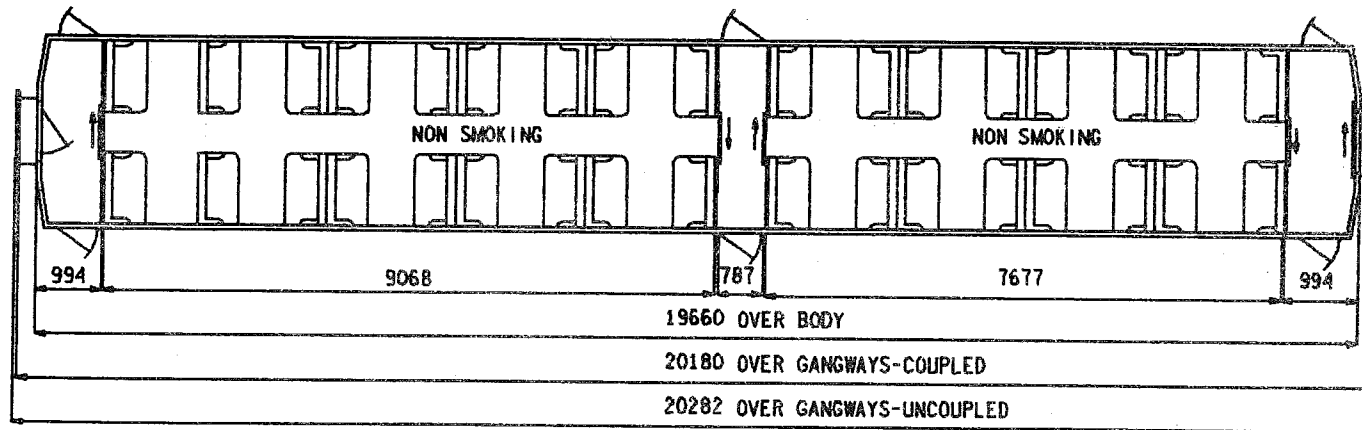
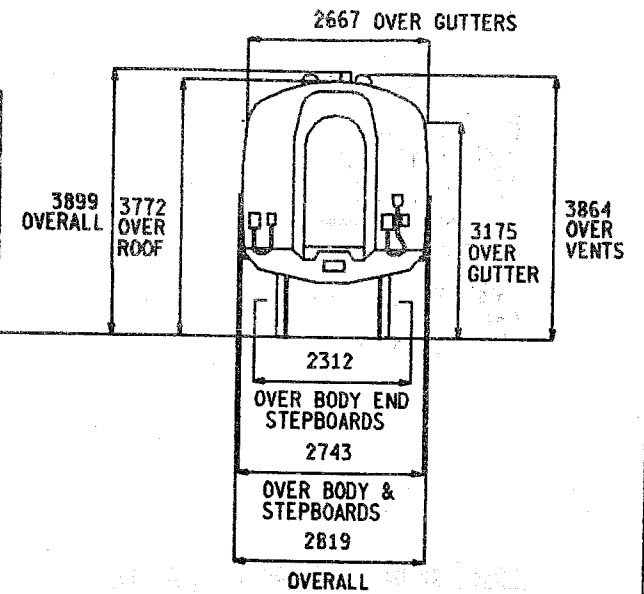
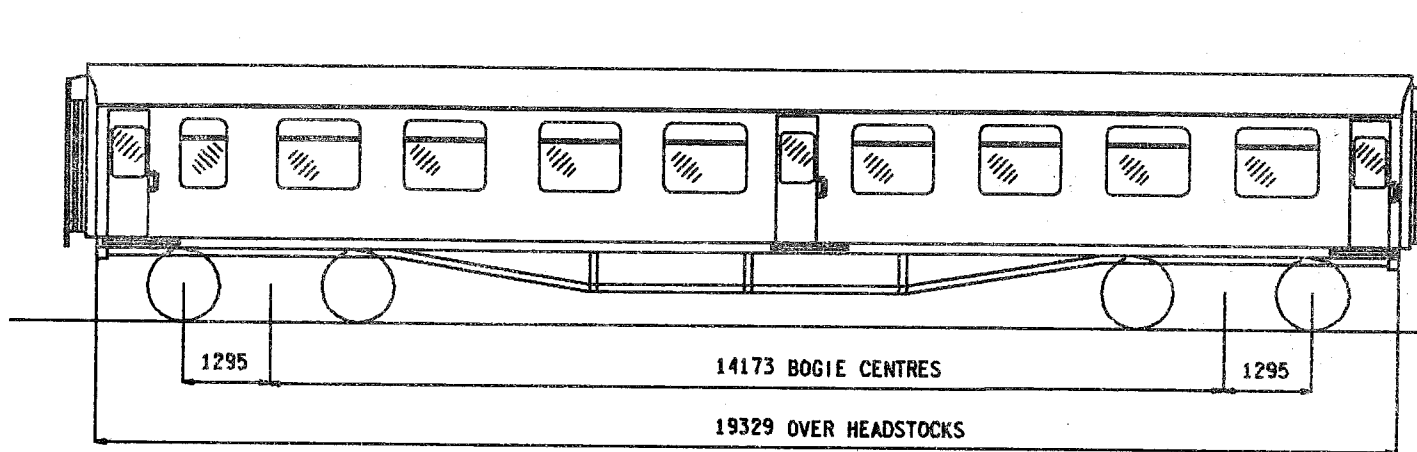

SEATS	68
TOILETS	-
COMPARTMENTS	-
GUARDS COMPARTMENTS	-
VENTILATION	-
CATERING EQUIPMENT	-

ISSUE 1 DATE OCT '86

EH 228

BRAKES
BOGIE/SUSPENSION
BODY CONSTRUCTION
COUPLINGS
TRAIN HEATING
MAX.SPEED M.P.H.
MIN.RAD.CURVE CHAINS
LIGHTING
TARE WEIGHT TONNES
GANGWAYS
TRAIN COMMUNICATION
BUFFERS

BASIC TYPE

ELECTRO PNEUMATIC
COMMONWEALTH
STEEL
AUTOMATIC SOLID SHANK (ALLIANCE NO.2)
ELECTRIC (BR)
100
3.5
FLUORESCENT & TUNGSTEN
35
PULLMAN
PUBLIC ADDRESS
NOT FITTED

ALTERNATIVES

TRACTION DATA FOR MULTIPLE UNITS

EMI- LIVERPOOL ST.-CLACTON & WALTON INTRODUCED 1962, REFURBISHED 1985.
VOLTAGE 25 & 6.25 KV A.C.OVERHEAD.

BASIC TYPE

EH 228 0A

VARIANTS

NONE

TRAILER SECOND

CLASS 309/3

TS

EH 229

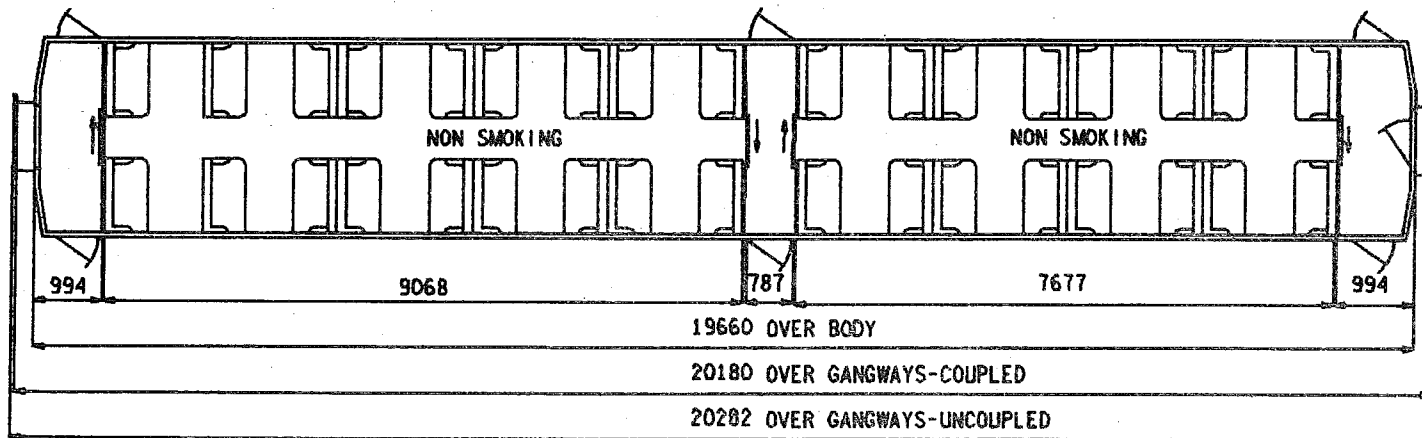
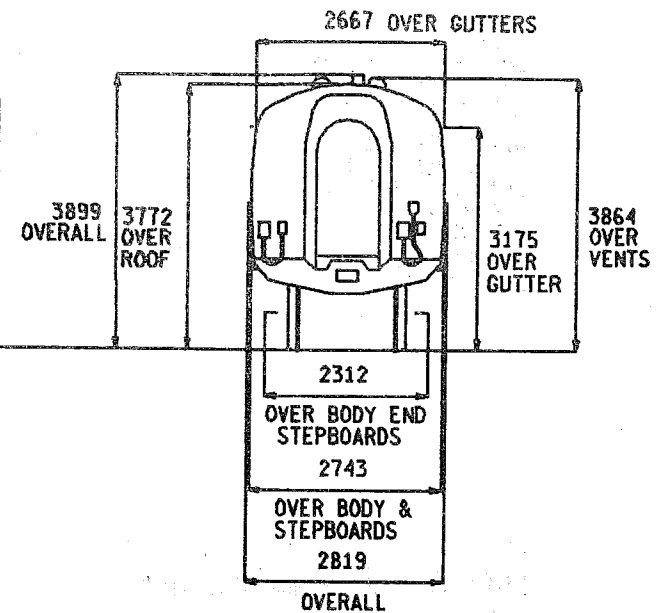
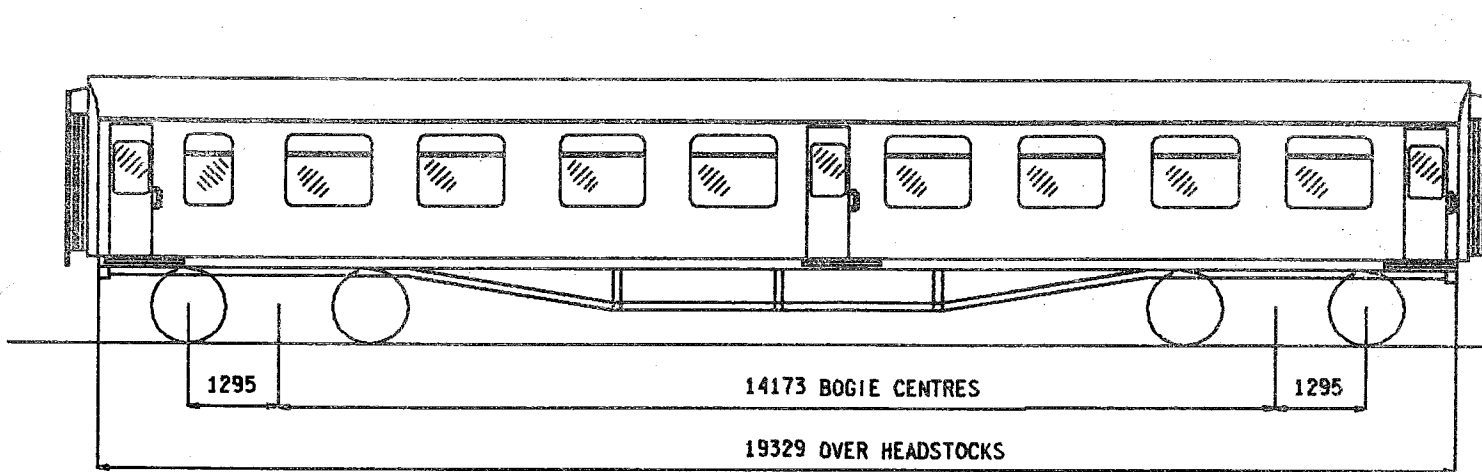

SEATS	68
TOILETS	-
COMPARTMENTS	-
GUARDS COMPARTMENTS	-
VENTILATION	-
CATERING EQUIPMENT	-

ISSUE	DATE
1	OCT '86

EH 229

BRAKES
BOGIE/SUSPENSION
BODY CONSTRUCTION
COUPLINGS
TRAIN HEATING
MAX. SPEED M.P.H.
MIN. RAD. CURVE CHAINS
LIGHTING
TARE WEIGHT TONNES
GANGWAYS
TRAIN COMMUNICATION
BUFFERS

BASIC TYPE

ELECTRO PNEUMATIC
COMMONWEALTH
STEEL
AUTOMATIC SOLID SHANK (ALLIANCE NO. 2)
ELECTRIC (BR)
100
3.5
FLUORESCENT & TUNGSTEN
35
PULLMAN
PUBLIC ADDRESS
NOT FITTED

ALTERNATIVES

TRACTION DATA FOR MULTIPLE UNITS

EMU- LIVERPOOL ST.-CLACTON & WALTON INTRODUCED 1962, REFURBISHED 1985.
VOLTAGE 25 & 6.25 KV A.C. OVERHEAD.

BASIC TYPE

EH 229 0A

VARIANTS

NONE

TRAILER STANDARD

CLASS 310/0
CLASS 310/1

TS

EH 232

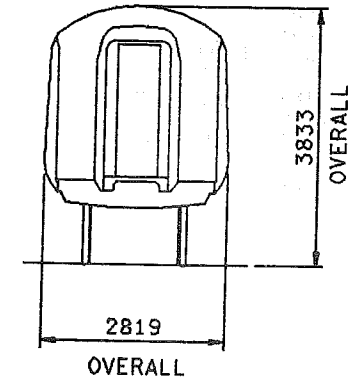
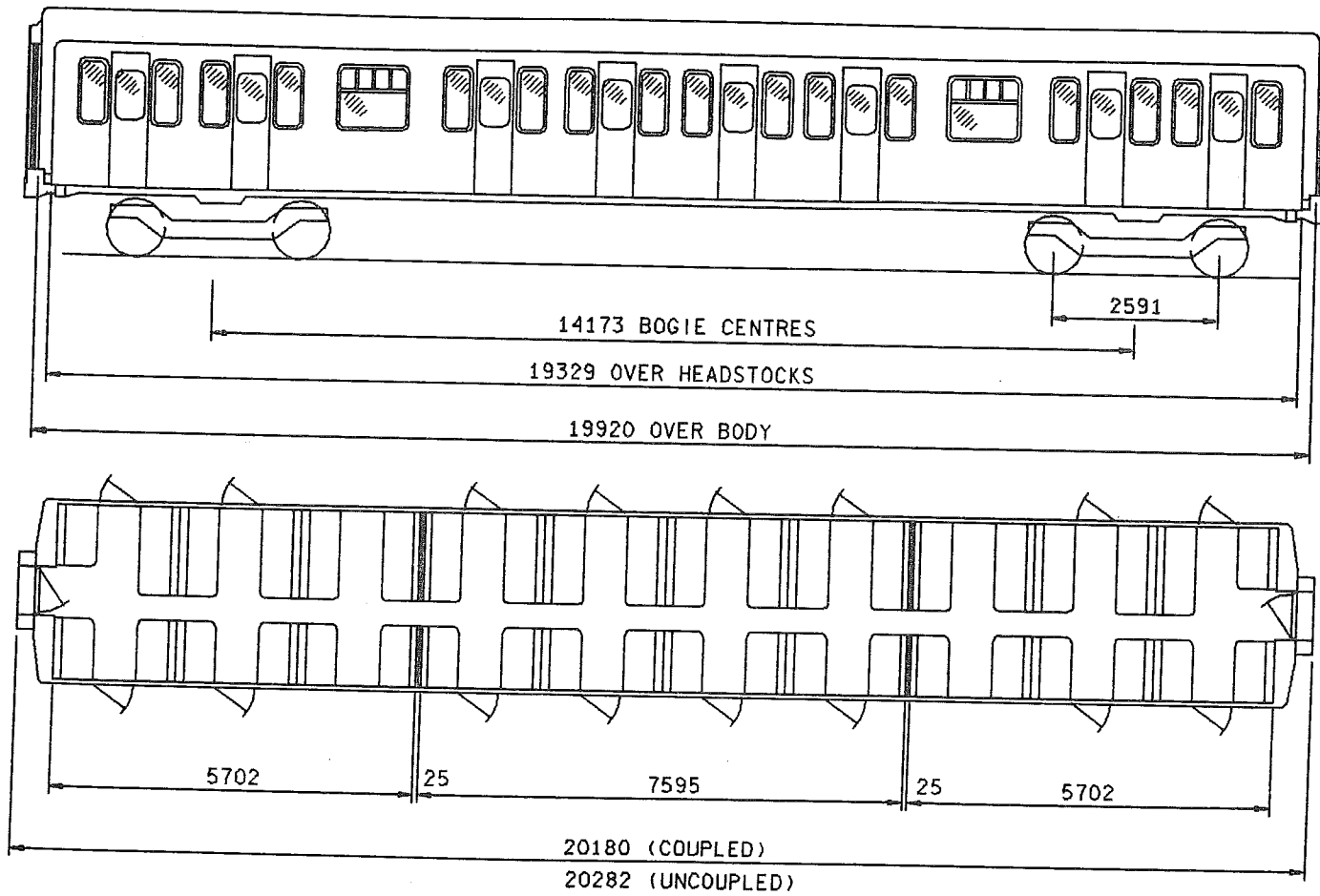

SEATS	98
TOILETS	-
COMPARTMENTS	-
GUARDS COMPARTMENTS	-
VENTILATION	-
CATERING EQUIPMENT	-

ISSUE 1 DATE AUG '88

EH 232

BRAKES
BOGIE/SUSPENSION
BODY CONSTRUCTION
COUPLINGS
TRAIN HEATING
MAX.SPEED M.P.H.
MIN.RAD.CURVE CHAINS
LIGHTING
TARE WEIGHT TONNES
GANGWAYS
TRAIN COMMUNICATION
BUFFERS

BASIC TYPE

ELECTRO PNEUMATIC
B4/AM10 T
STEEL
AUTOMATIC SOLID SHANK(BUCKEYE)
ELECTRIC(BR)
75
3.5
ELECTRIC
31.5
EXPRESS ELECTRIC
PUBLIC ADDRESS
NOT FITTED

ALTERNATIVES

TRACTION DATA FOR MULTIPLE UNITS

EMU- EUSTON-BIRMINGHAM-MANCHESTER & LIVERPOOL INTRODUCED 1966, FACELIFTED 1985.
VOLTAGE 25 KV A.C.OVERHEAD.

BASIC TYPE

EH 232 0A

VARIANTS

1B REFURBISHED & RECLASSIFIED CLASS 310/1

TRAILER STANDARD (AUXILIARY)

CLASS 319

TS

EH 234

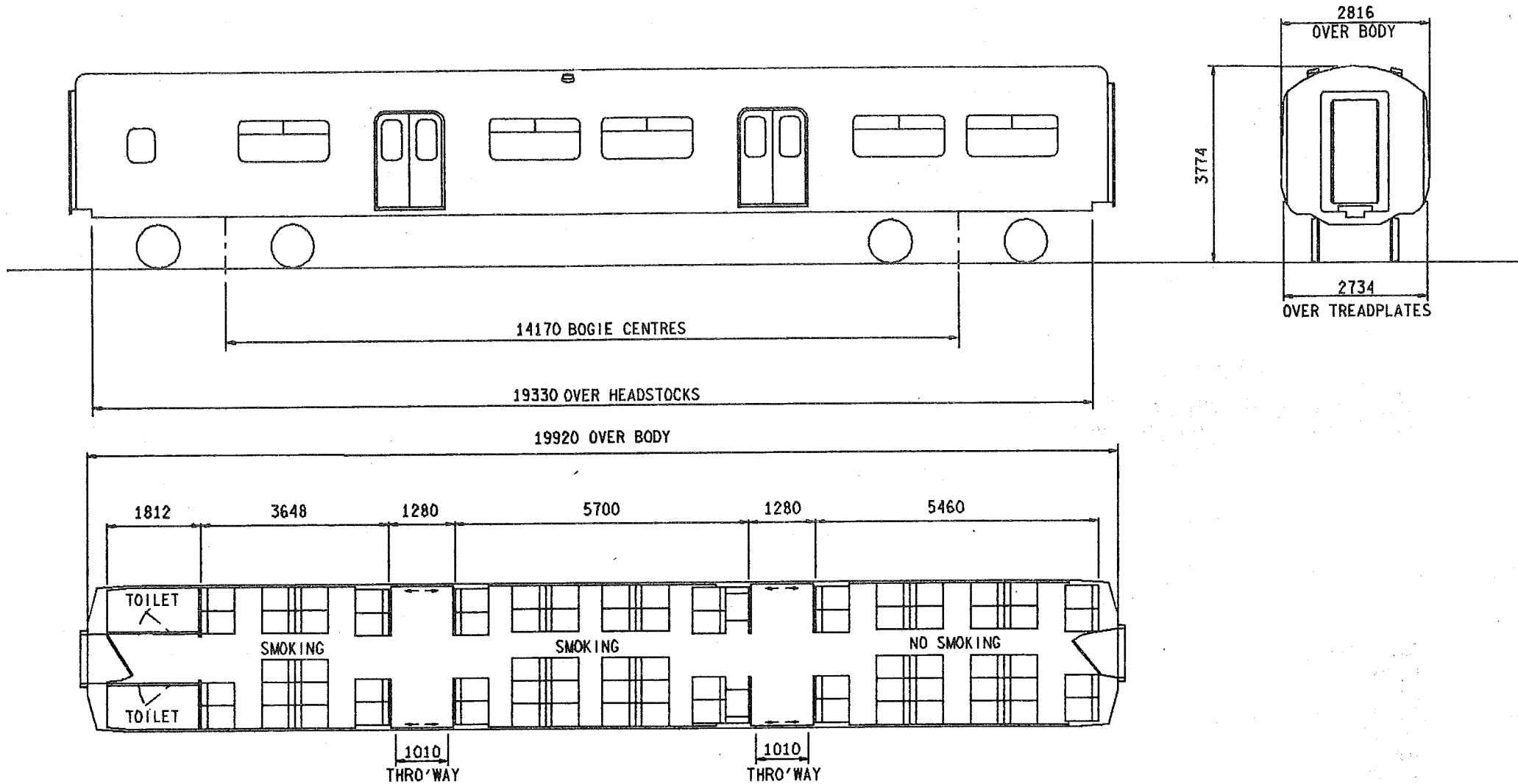

SEATS	76
TOILETS	2
COMPARTMENTS	-
GUARDS COMPARTMENTS	-
VENTILATION	-
CATERING EQUIPMENT	-

ISSUE 1 DATE JAN 88

EH 234

BRAKES
BOGIE/SUSPENSION
BODY CONSTRUCTION
COUPLINGS
TRAIN HEATING
MAX. SPEED M.P.H.
MIN. RAD. CURVE CHAINS
LIGHTING
TARE WEIGHT TONNES
GANGWAYS
A.W.S.
TRAIN COMMUNICATION
BUFFERS

BASIC TYPE

ELECTRO-PNEUMATIC
T3-7c & T3-7d (ONE OF EACH)
STEEL
BAR
ELECTRIC (BR)
100
3.5
FLUORESCENT
31
FLEXIBLE DIAPHRAGM/RIGID (GRP)
FITTED
PUBLIC ADDRESS
NOT FITTED

ALTERNATIVES

TRACTION DATA FOR MULTIPLE UNITS

EMU- CROSS LONDON SERVICES. INTRODUCED 1987
VOLTAGE 25 KV A.C. OVERHEAD & 750V D.C. THIRD RAIL

BASIC TYPE

EH 234 OA

VARIANTS

NONE

TRAILER STANDARD (AUXILIARY)

CLASS 321

TS

EH 235

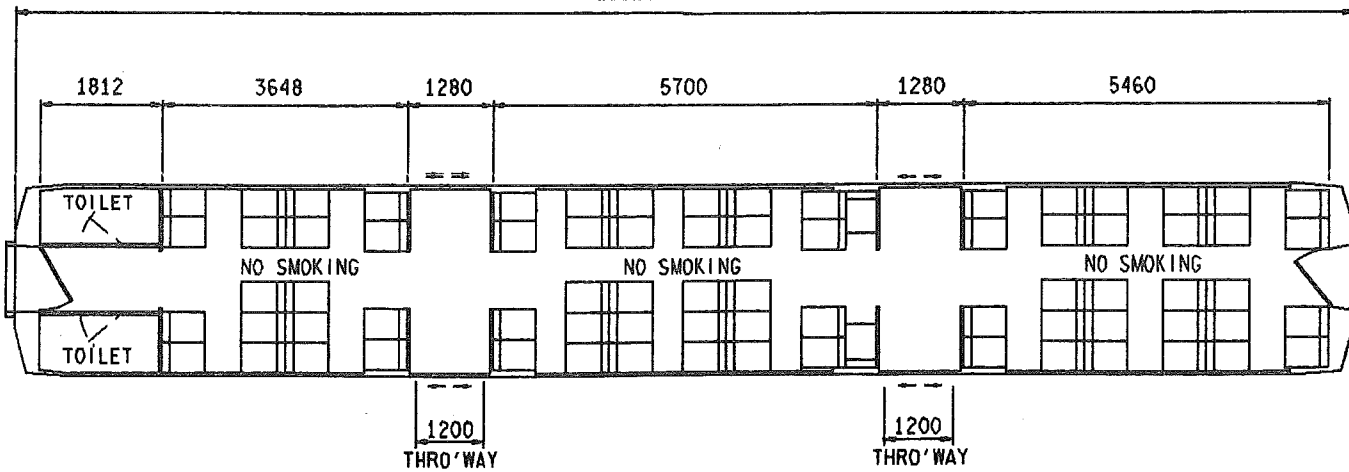
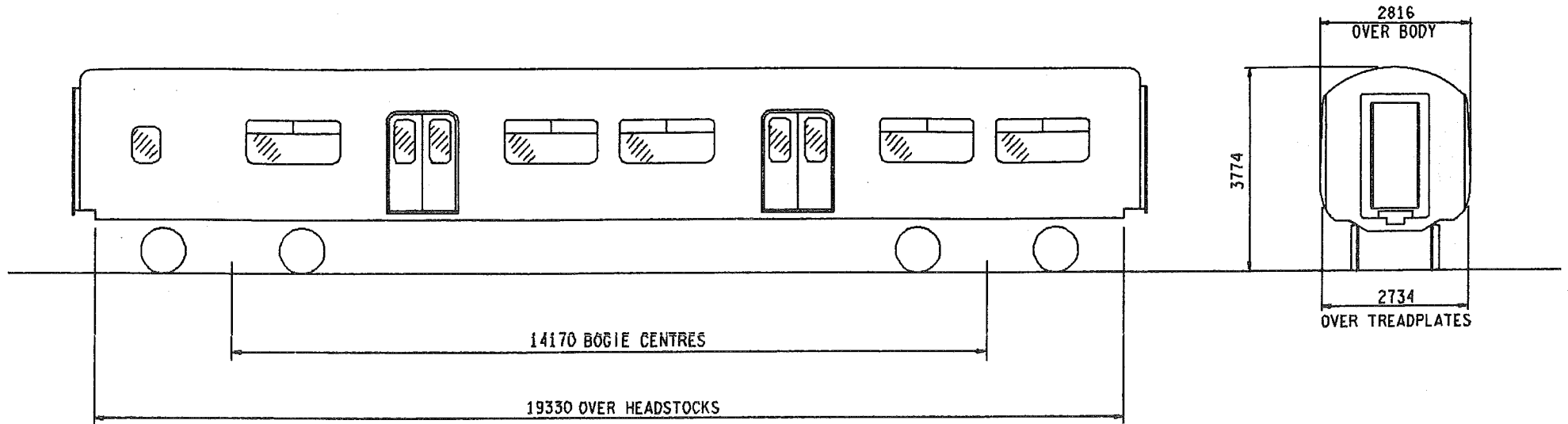

SEATS	76
TOILETS	2
COMPARTMENTS	-
GUARDS COMPARTMENTS	-
VENTILATION	-
CATERING EQUIPMENT	-

ISSUE 1 DATE OCT 88

EH 235

BRAKES
BOGIE/SUSPENSION
BODY CONSTRUCTION
COUPLINGS
TRAIN HEATING
MAX. SPEED M.P.H.
MIN. RAD. CURVE METRES
LIGHTING
TARE WEIGHT TONNES
GANGWAYS
A.W.S.
TRAIN COMMUNICATION
BUFFERS

BASIC TYPE

ELECTRO-PNEUMATIC
T3-7n & T3-7m(ONE OF EACH)
STEEL
BAR
ELECTRIC(BR)
100
71
FLUORESCENT
28.8
FLEXIBLE DIAPHRAGM/RIGID(GRP)
NOT FITTED
PUBLIC ADDRESS
NOT FITTED

ALTERNATIVES

TRACTION DATA FOR MULTIPLE UNITS

EMU- ANGLIA-ELECTRICS INTRODUCED 1988/89.

VOLTAGE 25 KV A.C.OVERHEAD

BASIC TYPE

EH 235 0A

VARIANTS

NONE

TRAILER SECOND

CLASS 487

TS

EH 260

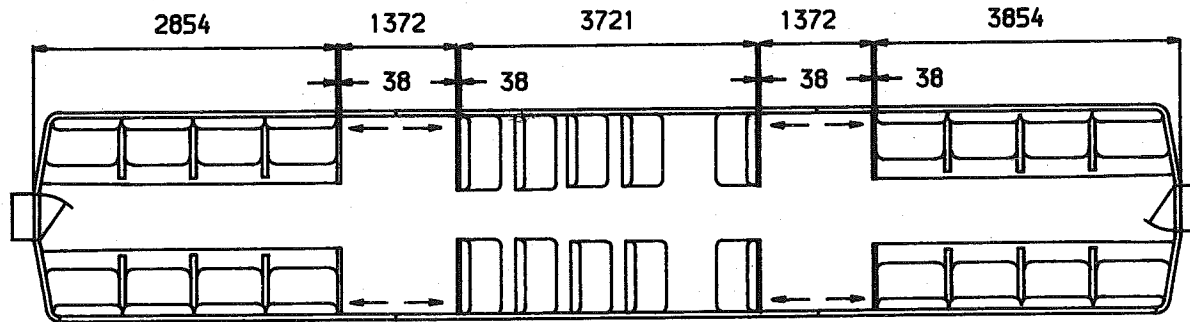
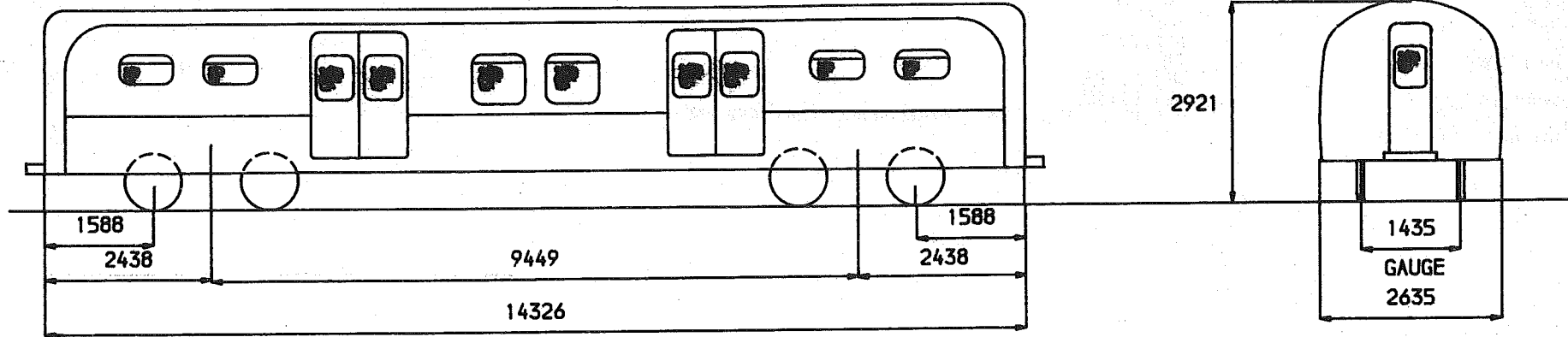

SEATS	52
TOILETS	-
COMPARTMENTS	-
GUARDS COMPARTMENTS	-
VENTILATION	-
CATERING EQUIPMENT	-

ORIGINAL DIAGRAMS FOR REFERENCE.-
S.R.846

ISSUE	DATE
1	SEP' 80

EH 260

BRAKES
BOGIE/SUSPENSION
BODY CONSTRUCTION
COUPLINGS
TRAIN HEATING
MAX. SPEED M.P.H.
MIN. RAD. CURVE CHAINS
LIGHTING
TARE WEIGHT TONNES
GANGWAYS
TRAIN COMMUNICATION
BUFFERS
S.R. DESIGN REFERENCE CODE

BASIC TYPE

AIR
WATERLOO & CITY
STEEL
WATERLOO & CITY
ELECTRIC (BR)
NO RECORD
3.5
ELECTRIC
20
NOT FITTED
NOT FITTED
CENTRE SPRING A END-CENTRE WEARING BLOCK B END
DAG

ALTERNATIVES

TRACTION DATA FOR MULTIPLE UNITS

EMU- WATERLOO & CITY. INTRODUCED 1940.
VOLTAGE 750/850 VOLTS D.C. THIRD RAIL

BASIC TYPE

EH 260 0A

VARIANTS

NONE

TRAILER SECOND

CLASS 485
486

TS

EH 261

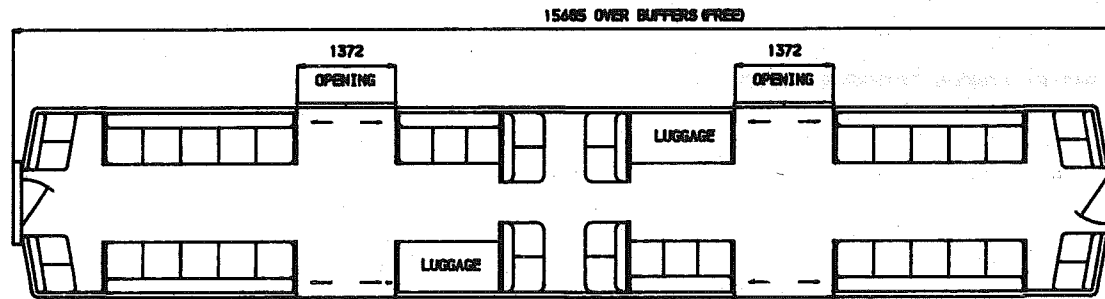
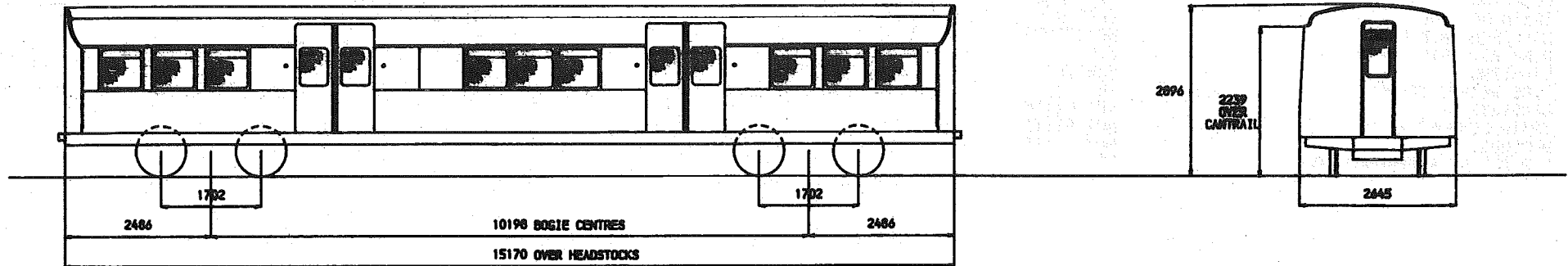

SEATS	42
TOILETS	-
COMPARTMENTS	-
GUARDS COMPARTMENTS	-
VENTILATION	-
CATERING EQUIPMENT	-

ORIGINAL DIAGRAMS FOR REFERENCE.-
S.R. 849

ISSUE 1 DATE SEP' 80

EH 261

BRAKES
BOGIE/SUSPENSION
BODY CONSTRUCTION
COUPLINGS
TRAIN HEATING
MAX. SPEED M. P. H.
MIN. RAD. CURVE CHAINS
LIGHTING
TARE WEIGHT TONNES
GANGWAYS
TRAIN COMMUNICATION
BUFFERS
S. R. DESIGN REFERENCE CODE

BASIC TYPE

ELECTRO PNEUMATIC
EX LONDON TRANSPORT
STEEL UNDERFRAME, BODY & ROOF-WOODEN BODY FRAMING
EX LONDON TRANSPORT
ELECTRIC (BR)
NO RECORD
3.5
ELECTRIC
18
NOT FITTED
NOT FITTED
NOT FITTED
DAF

ALTERNATIVES

TRACTION DATA FOR MULTIPLE UNITS

EMU- ISLE OF WIGHT STOCK. INTRODUCED 1967-EX LONDON TRANSPORT STOCK.
VOLTAGE 630 VOLTS D.C. THIRD RAIL

BASIC TYPE

EH 261 0A

VARIANTS

NONE

TRAILER SECOND

CLASS 405

TS

EH 262

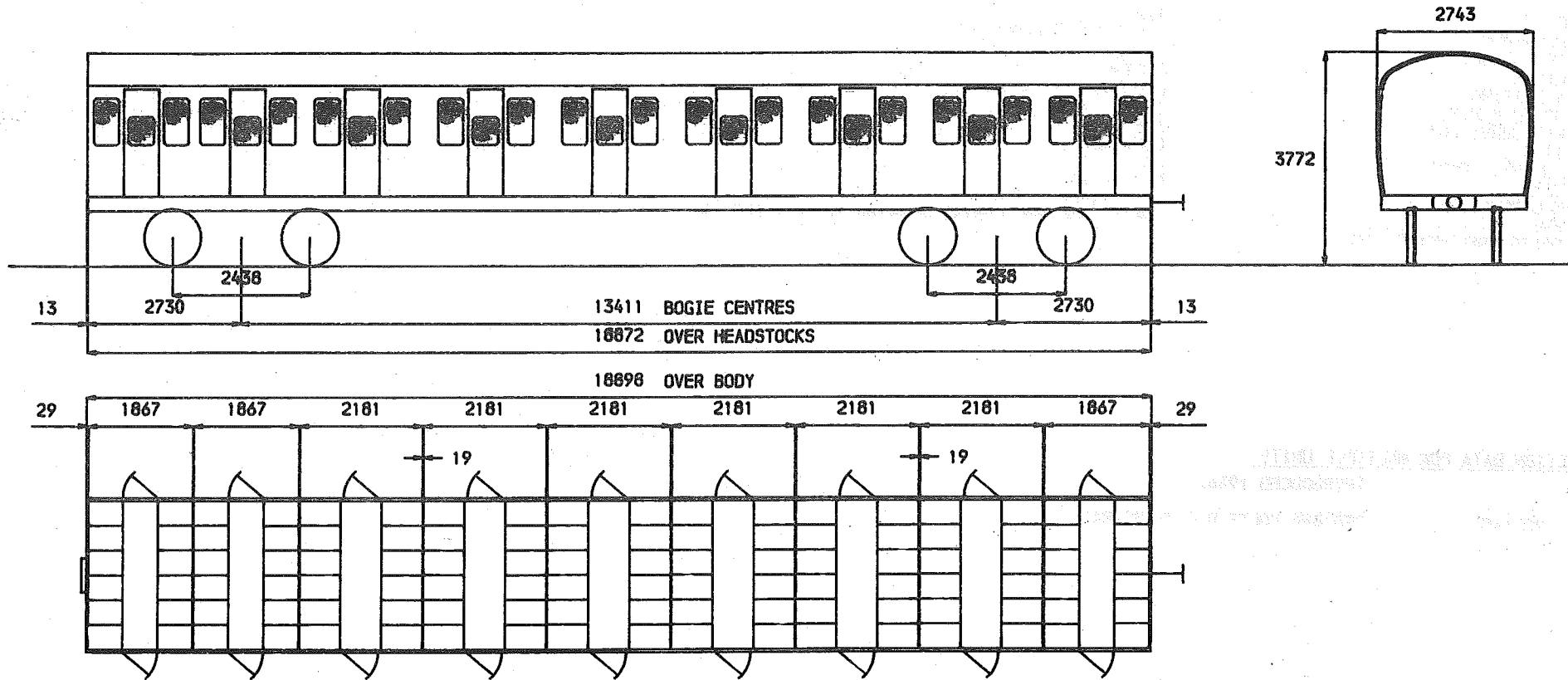

SEATS	108
TOILETS	-
COMPARTMENTS	9
GUARDS COMPARTMENTS	-
VENTILATION	-
CATERING EQUIPMENT	-

ORIGINAL DIAGRAMS FOR REFERENCE.-
S.R. 2314

ISSUE	DATE
1	SEP' 80

EH 262

BRAKES
BOGIE/SUSPENSION
BODY CONSTRUCTION
COUPLINGS
TRAIN HEATING
MAX. SPEED M.P.H.
MIN. RAD. CURVE CHAINS
LIGHTING
TARE WEIGHT TONNES
GANGWAYS
TRAIN COMMUNICATION
BUFFERS
S.R. DESIGN REFERENCE CODE

BASIC TYPE

AIR
S.R. STANDARD 229 X 114
STEEL
3 LINK
ELECTRIC (BR)
75
3.5
ELECTRIC
28
NOT FITTED
NOT FITTED
CENTRE ONE END-CENTRE WEARING PLATE OTHER END
DL

ALTERNATIVES

TRACTION DATA FOR MULTIPLE UNITS

EMU- INTRODUCED 1946.
VOLTAGE 750/850 VOLTS D.C. THIRD RAIL

BASIC TYPE

EH 262 0A

VARIANTS

NONE

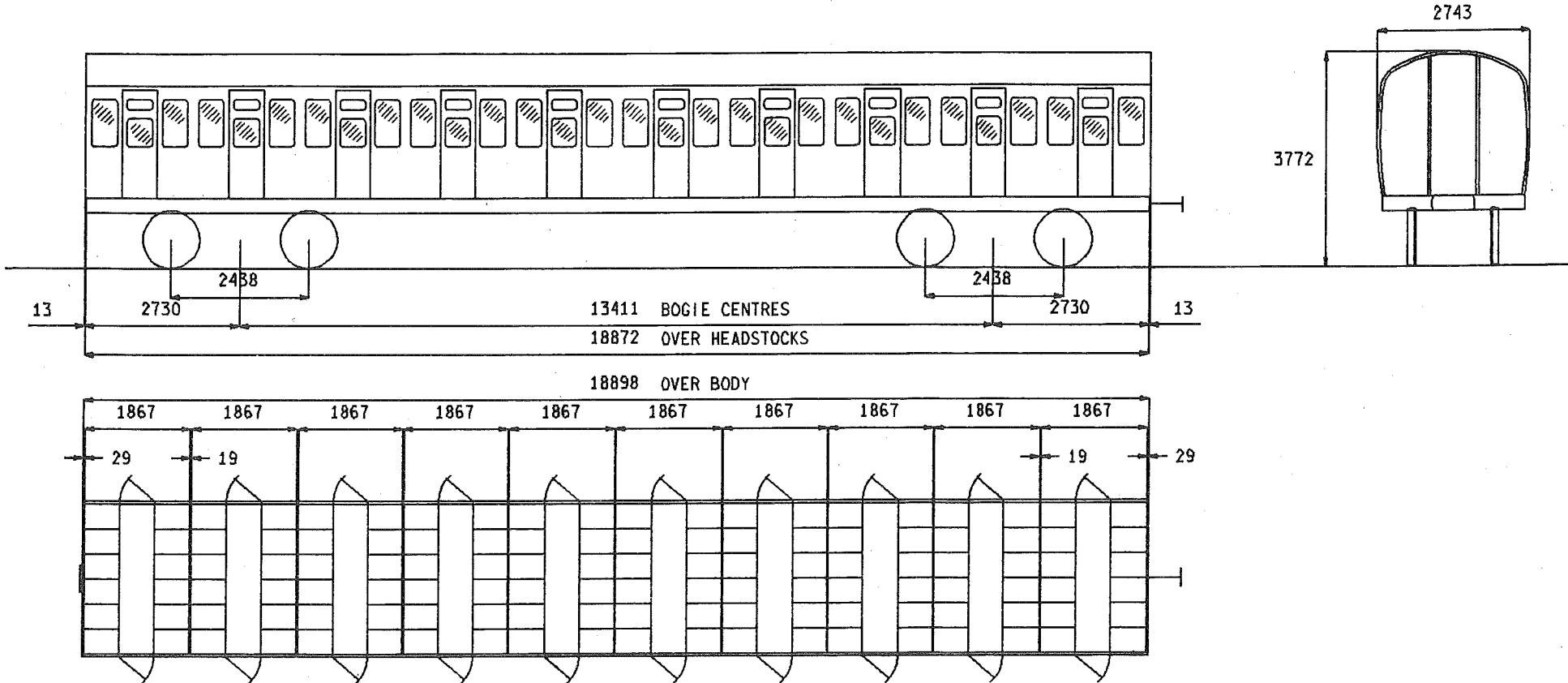

SEATS	120
TOILETS	-
COMPARTMENTS	10
GUARDS COMPARTMENTS	-
VENTILATION	-
CATERING EQUIPMENT	-

ORIGINAL DIAGRAMS FOR REFERENCE:-
S.R.2013

ISSUE DATE
2 MAR 86

EH 263

BRAKES
BOGIE/SUSPENSION
BODY CONSTRUCTION
COUPLINGS
TRAIN HEATING
MAX.SPEED M.P.H.
MIN.RAD.CURVE CHAINS
LIGHTING
TARE WEIGHT TONNES
GANGWAYS
A.W.S.
BUFFERS
S.R.DESIGN REFERENCE CODE

BASIC TYPE

AIR
S.R.STANDARD-229X114
STEEL
3 LINK
ELECTRIC(BR)
75
3.5
TUNGSTEN
27
NOT FITTED
NOT FITTED
CENTRE ONE END-CENTRE WEARING PLATE OTHER END
DN

ALTERNATIVES

TRACTION DATA FOR MULTIPLE UNITS

EMU- INTRODUCED 1946.
VOLTAGE 750/850 VOLTS D.C.THIRD RAIL

BASIC TYPE

EH 263 0A

VARIANTS

NONE

TRAILER SECOND

CLASS 405

TS

EH 265

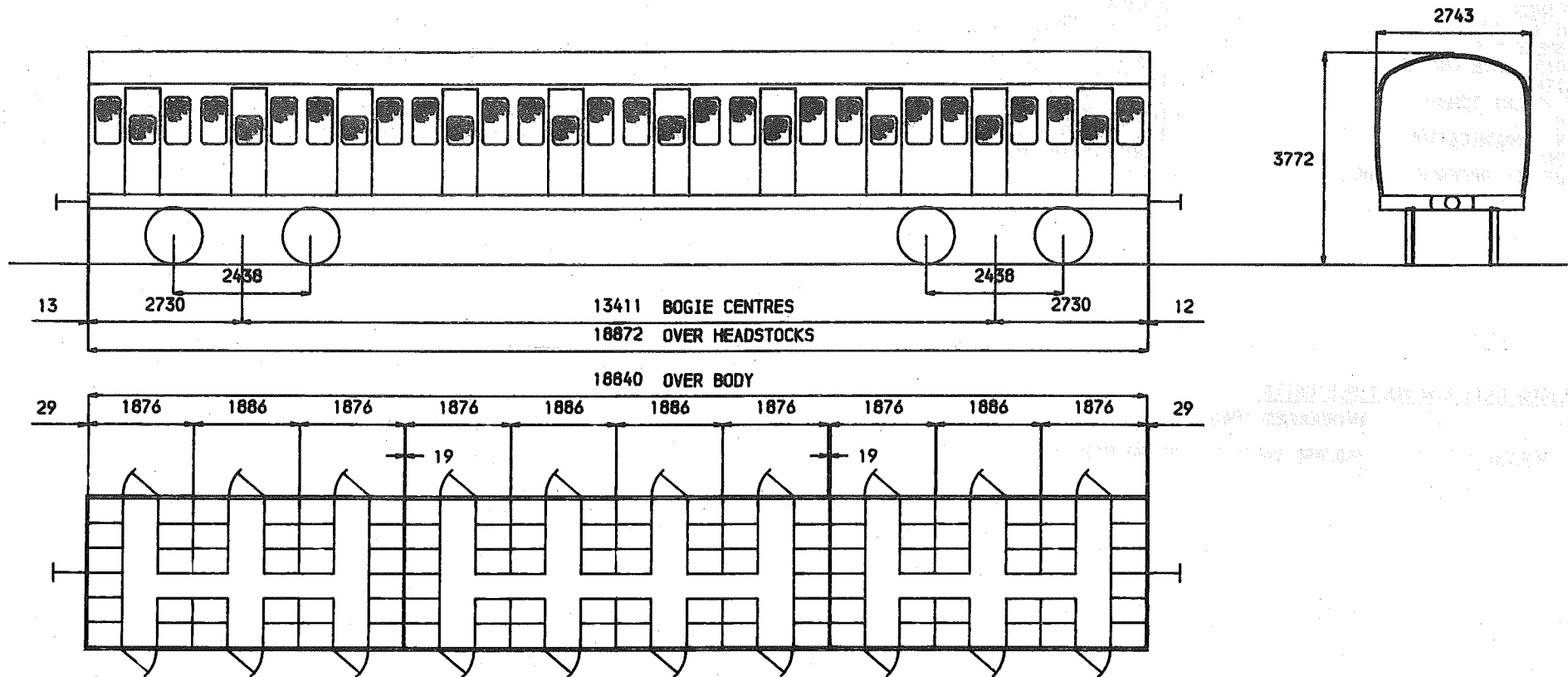

SEATS	106
TOILETS	-
COMPARTMENTS	-
GUARDS COMPARTMENTS	-
VENTILATION	-
CATERING EQUIPMENT	-

ORIGINAL DIAGRAMS FOR REFERENCE.-
S.R. 2015

ISSUE	DATE
1	SEP' 80

EH 265

BRAKES
BOGIE/SUSPENSION
BODY CONSTRUCTION
COUPLINGS
TRAIN HEATING
MAX. SPEED M.P.H.
MIN. RAD. CURVE CHAINS
LIGHTING
TARE WEIGHT TONNES
GANGWAYS
TRAIN COMMUNICATION
BUFFERS
S.R. DESIGN REFERENCE CODE

BASIC TYPE

AIR
S.R. STANDARD 229 X 114
STEEL
3 LINK
ELECTRIC (BR)
75
3.5
ELECTRIC
28
NOT FITTED
NOT FITTED
CENTRE BOTH ENDS
DM

ALTERNATIVES

TRACTION DATA FOR MULTIPLE UNITS

EMU- INTRODUCED 1946.
VOLTAGE 750/850 VOLTS D.C. THIRD RAIL

BASIC TYPE

EH 265 0A

VARIANTS

NONE

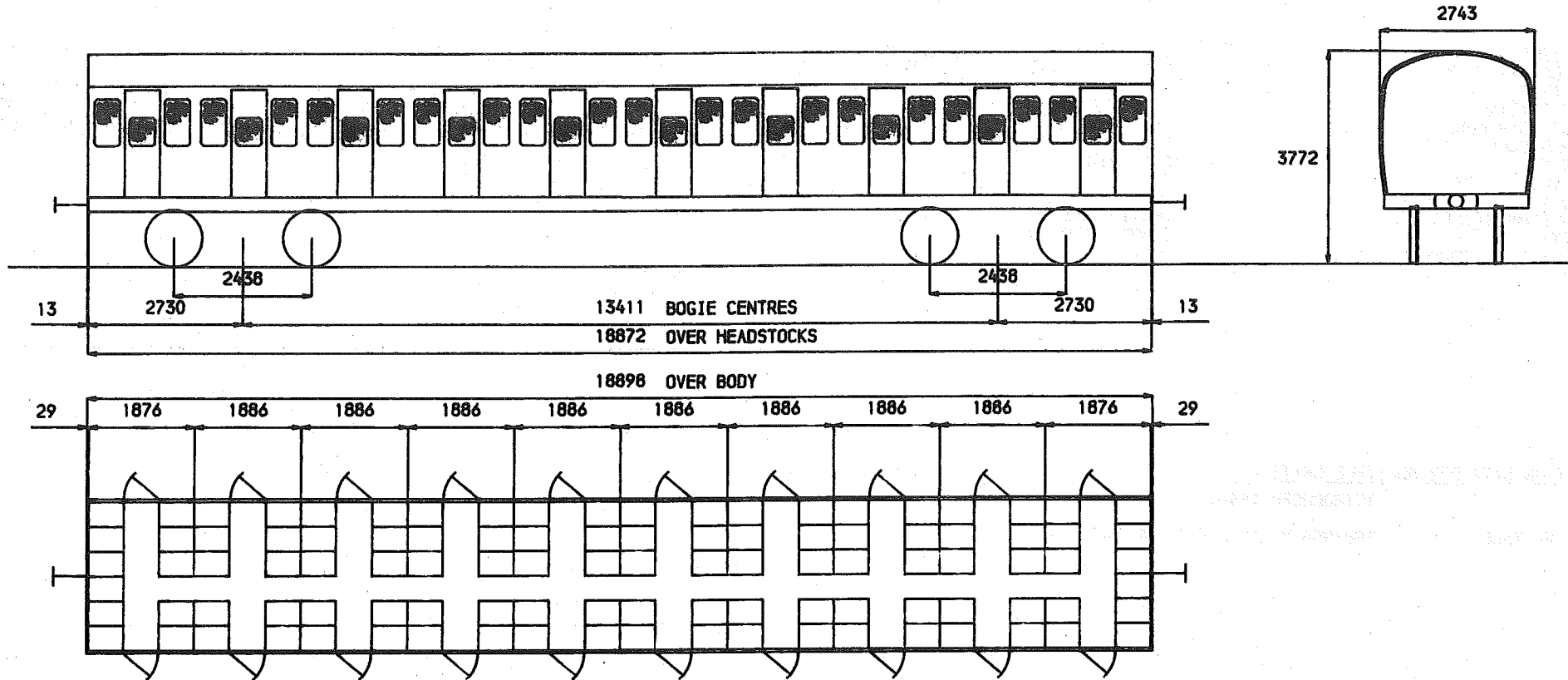

SEATS	102
TOILETS	-
COMPARTMENTS	-
GUARDS COMPARTMENTS	-
VENTILATION	-
CATERING EQUIPMENT	-

ORIGINAL DIAGRAMS FOR REFERENCE.-
S.R. 2018

ISSUE 1 DATE SEP' 80

EH 266

BRAKES
BOGIE/SUSPENSION
BODY CONSTRUCTION
COUPLINGS
TRAIN HEATING
MAX. SPEED M.P.H.
MIN. RAD. CURVE CHAINS
LIGHTING
TARE WEIGHT TONNES
GANGWAYS
TRAIN COMMUNICATION
BUFFERS
S.R. DESIGN REFERENCE CODE

BASIC TYPE

AIR
S.R. STANDARD 229 X 114
STEEL
3 LINK
ELECTRIC (BR)
75
3.5
ELECTRIC
26
NOT FITTED
NOT FITTED
CENTRE BOTH ENDS
DR

ALTERNATIVES

TRACTION DATA FOR MULTIPLE UNITS

EMU- INTRODUCED 1946.
VOLTAGE 750/850 VOLTS D.C. THIRD RAIL

BASIC TYPE

EH 265 0A

VARIANTS

OB MODIFIED INTERIOR WITH TRANSVERSE SEMI-PARTITIONS.

TRAILER SECOND

CLASS 415/0

TS

EH 267

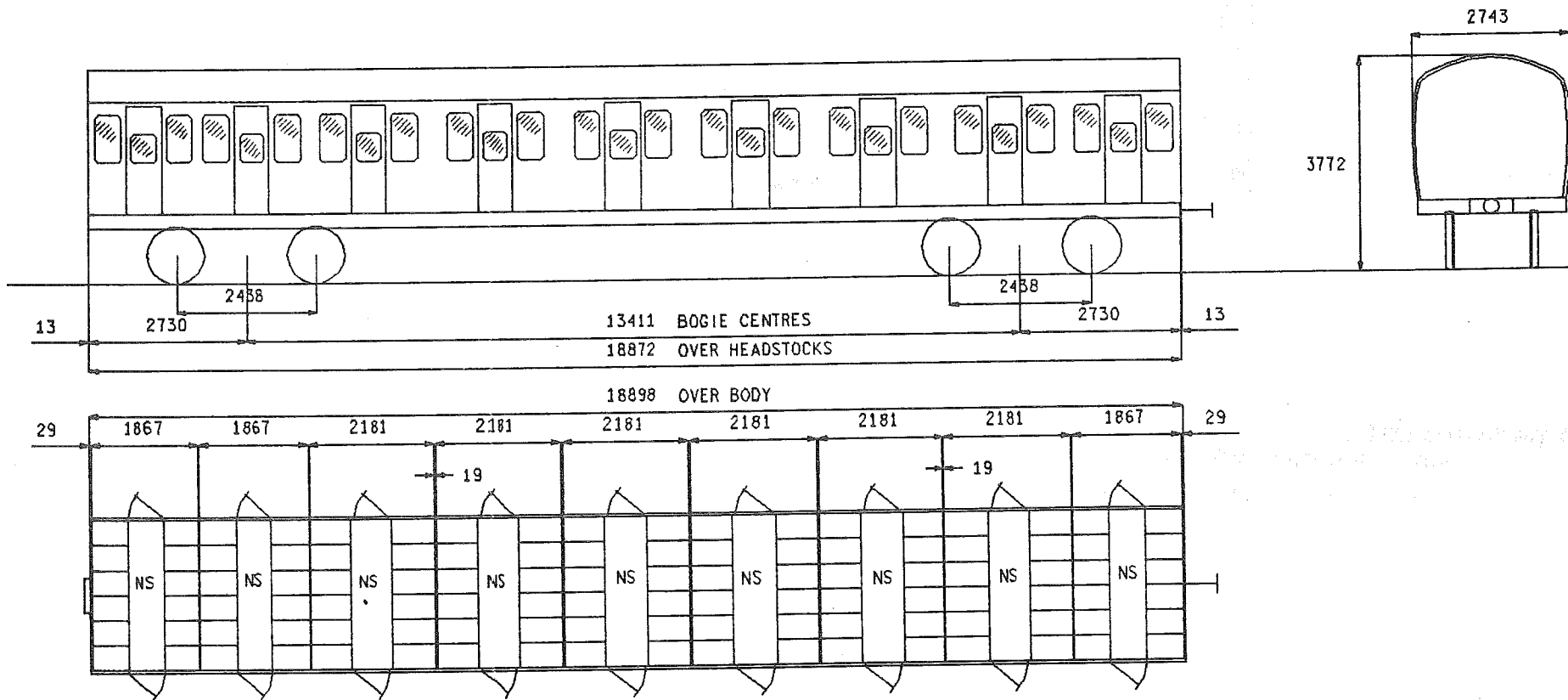

SEATS	108
TOILETS	-
COMPARTMENTS	9
GUARDS COMPARTMENTS	-
VENTILATION	-
CATERING EQUIPMENT	-

ORIGINAL DIAGRAMS FOR REFERENCE:-
S.R.2314

ISSUE	DATE
3	NOV 84

EH 267

BASIC TYPE

BRAKES
BOGIE/SUSPENSION
BODY CONSTRUCTION
COUPLINGS
TRAIN HEATING
MAX.SPEED M.P.H.
MIN.RAD.CURVE CHAINS
LIGHTING
TARE WEIGHT TONNES
GANGWAYS
TRAIN COMMUNICATION
BUFFERS
S.R.DESIGN REFERENCE CODE

ELECTRO PNEUMATIC
S.R.STANDARD 229 X 114
STEEL
3 LINK
ELECTRIC(BR)
75
3.5
TUNGSTEN
28
NOT FITTED
NOT FITTED
CENTRE ONE END-CENTRE WEARING PLATE OTHER END
DU

ALTERNATIVES

DU 1A

TRACTION DATA FOR MULTIPLE UNITS

EMU- INTRODUCED 1951, RECLASSED 1984.
VOLTAGE 750/850 VOLTS D.C. THIRD RAIL

BASIC TYPE

EH 267 OA

VARIANTS

1B S.R.DESIGN REFERENCE CODE DU 1A.

TRAILER SECOND

CLASS 415/0
415/3

TS

EH 268

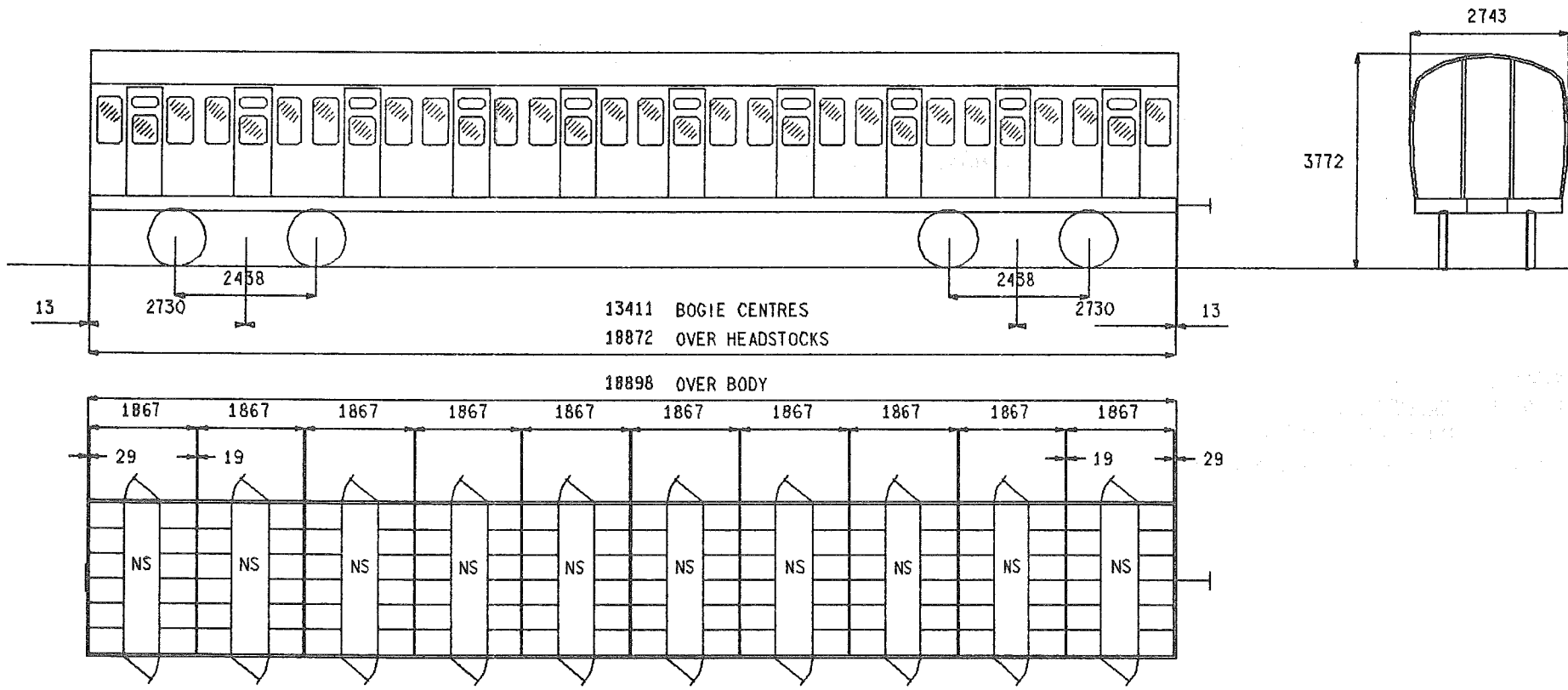

SEATS	120
TOILETS	-
COMPARTMENTS	10
GUARDS COMPARTMENTS	-
VENTILATION	-
CATERING EQUIPMENT	-

ORIGINAL DIAGRAMS FOR REFERENCE:-
S.R.2013

ISSUE 3 DATE NOV 84

EH 268

BRAKES
BOGIE/SUSPENSION
BODY CONSTRUCTION
COUPLINGS
TRAIN HEATING
MAX.SPEED M.P.H.
MIN.RAD.CURVE CHAINS
LIGHTING
TARE WEIGHT TONNES
GANGWAYS
TRAIN COMMUNICATION
BUFFERS

BASIC TYPE

ELECTRO PNEUMATIC
S.R.STANDARD 229 X 114
STEEL
3 LINK
ELECTRIC(BR)
75
3.5
TUNGSTEN
28
NOT FITTED
NOT FITTED
CENTRE ONE END-CENTRE WEARING PLATE OTHER END
DU

ALTERNATIVES

DU 1A

TRACTION DATA FOR MULTIPLE UNITS

EMU- INTRODUCED-CLASS 415/1 1951-CLASS 415/2 1957. RECLASSED 1984.
VOLTAGE 750/850 VOLTS D.C.THIRD RAIL

BASIC TYPE

EH 268 0A

VARIANTS

1B S.R.DESIGN REFERENCE CODE DU 1A.

TRAILER SECOND

CLASS 415/0
415/3

TS

EH 270

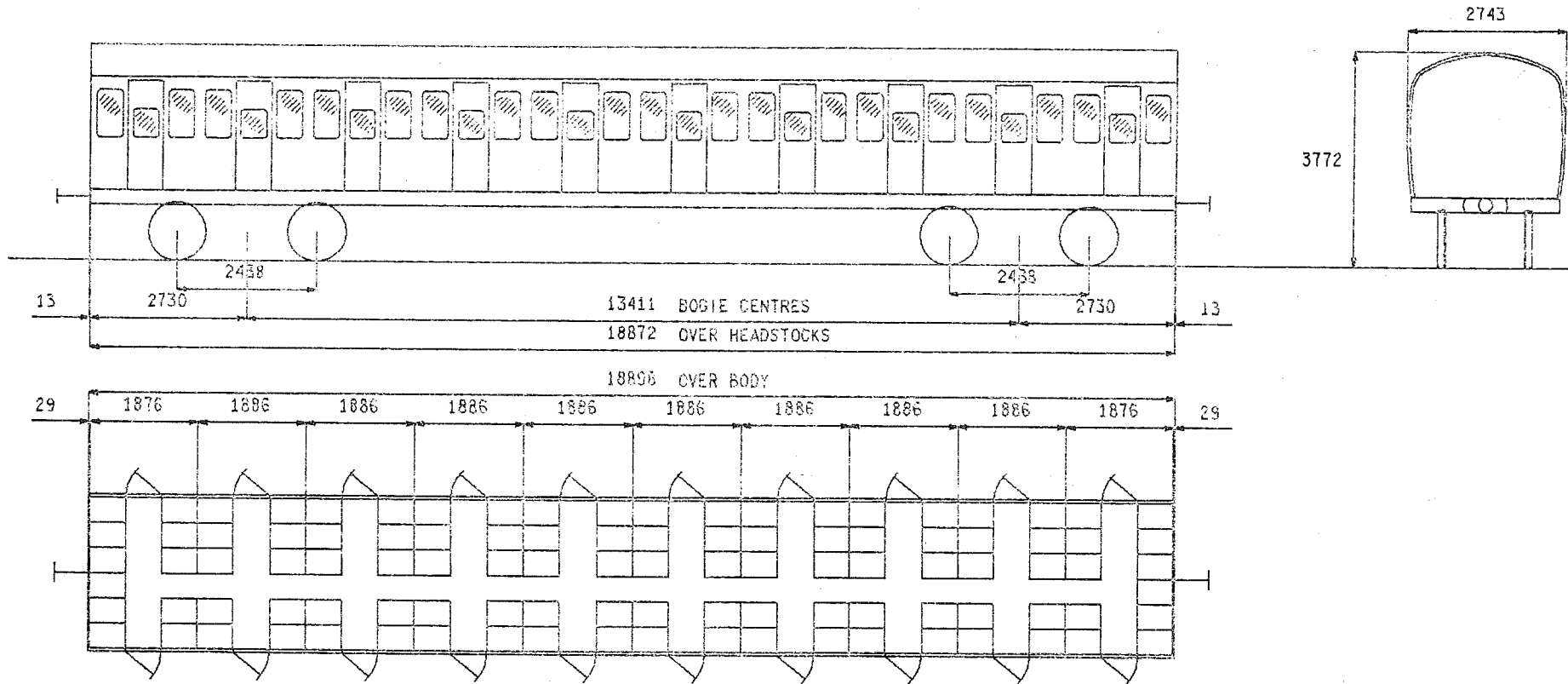

SEATS	102
TOILETS	-
COMPARTMENTS	-
GUARDS COMPARTMENTS	-
VENTILATION	-
CATERING EQUIPMENT	-

ORIGINAL DIAGRAMS FOR REFERENCE:-
SR 2018

ISSUE	DATE
4	JAN 84

EH 270

BASIC TYPE

BRAKES
BOGIE/SUSPENSION
BODY CONSTRUCTION
COUPLINGS
TRAIN HEATING
MAX.SPEED M.P.H.
MIN.RAD.CURVE CHAINS
LIGHTING
TARE WEIGHT TONNES
GANGWAYS
TRAIN COMMUNICATION
BUFFERS
S.R.DESGIN REFERENCE CODE

ELECTRIC PNEUMATIC
S.R.STANDARD-229 X 114
STEEL
3 LINK
ELECTRIC(BR)
75
3.5
TUNGSTEN
27
NOT FITTED
NOT FITTED
CENTRE
DS

ALTERNATIVES

TRACTION DATA FOR MULTIPLE UNITS

EMU- INTRODUCED CLASS 415/1 1951, CLASS 415/2 1957, RECLASSED 1984.
VOLTAGE 750/850 VOLTS D.C. THIRD RAIL

BASIC TYPE

EH 270 OA

VARIANTS

NONE

TRAILER SECOND

CLASS 415/3

TS

EH 271

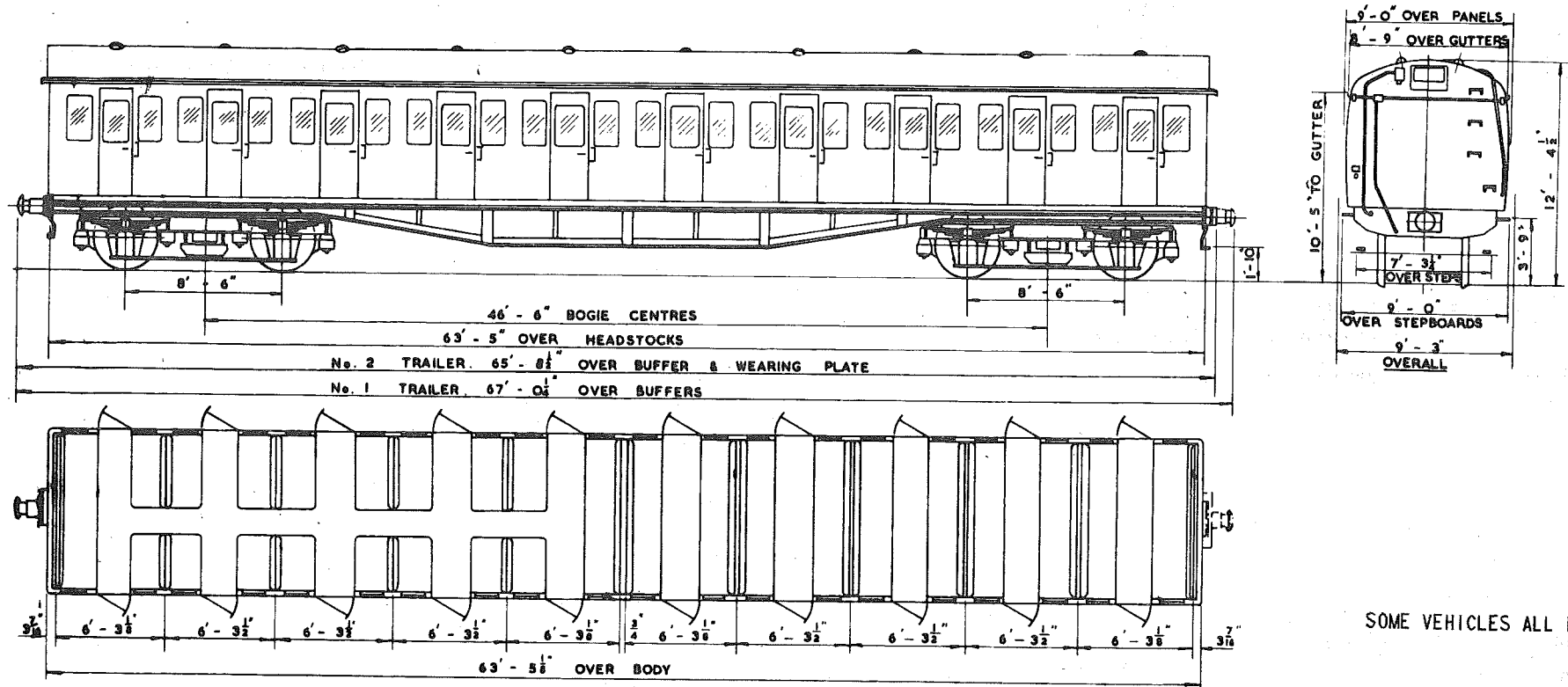

SOME VEHICLES ALL NON SMOKING

SEATS	112
TOILETS	-
COMPARTMENTS	5 PLUS 1 SALOON
GUARDS COMPARTMENTS	-
VENTILATION	-
CATERING EQUIPMENT	-

ORIGINAL DIAGRAMS FOR REFERENCE:-
BR 480

ISSUE 4 DATE AUG 85

EH 271

BRAKES
BOGIE/SUSPENSION
BODY CONSTRUCTION
COUPLINGS
TRAIN HEATING
MAX.SPEED M.P.H.
MIN.RAD.CURVE CHAINS
LIGHTING
TARE WEIGHT TONNES
GANGWAYS
TRAIN COMMUNICATION
BUFFERS
S.R.DESIGN REFERENCE CODE

BASIC TYPE

ELECTRO PNEUMATIC
S.R.MK 3D UNPOWERED
STEEL
3 LINK
ELECTRIC(BR)
75
3.5
TUNGSTEN
29.5
NOT FITTED
NOT FITTED
CENTRE
DAA

ALTERNATIVES

S.R.MK 3C UNPOWERED,B5(S.R)

CENTRE ONE END-CENTRE WEARING PLATE OTHER
DAA 1A,DAB,DAB 1A

TRACTION DATA FOR MULTIPLE UNITS

EMU- INTRODUCED 1957,RECLASSED 1984.
VOLTAGE 750/850 VOLTS D.C.THIRD RAIL

BASIC TYPE

EH 271 0A

VARIANTS

0B SR MK 3C UNPOWERED BOGIES.
0C SR DESIGN REF.CODE DAA 1A,SR MK 3C UNPOWERED BOGIES.
0D SR DESIGN REF.CODE DAA 1A,B5(SR)BOGIES.
1A SR DESIGN REF.CODE DAB,BUFFERS CENTRE ONE END-CENTRE WEARING PLATE OTHER END.
1B SR DESIGN REF.CODE DAB,BUFFERS CENTRE ONE END-CENTRE WEARING PLATE OTHER END,SR MK 3C UNPOWERED BOGIES.
1C SR DESIGN REF.CODE DAB 1A,BUFFERS CENTRE ONE END-CENTRE WEARING PLATE OTHER END,SR MK 3C UNPOWERED BOGIES.
1D SR DESIGN REF.CODE DAB 1A,BUFFERS CENTRE ONE END-CENTRE WEARING PLATE OTHER END.B5(SR)BOGIES.

TRAILER SECOND

CLASS 411/2

TS

EH 273

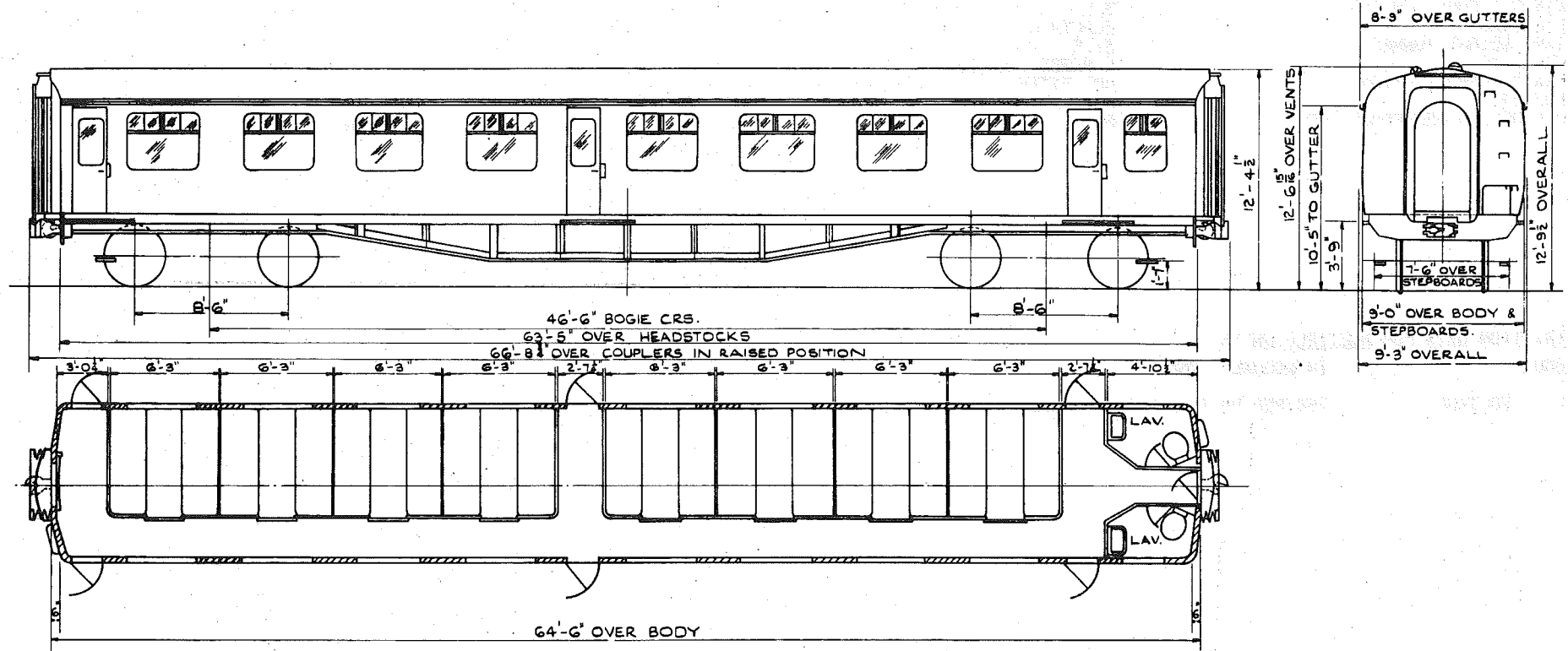

SEATS	64
TOILETS	2
COMPARTMENTS	8
GUARDS COMPARTMENTS	-
VENTILATION	-
CATERING EQUIPMENT	-

Original © BRB Residuary Ltd

Original diagrams courtesy of Eddie Knorn. This PDF copy by J.D. Faulkner, 2012

ORIGINAL DIAGRAMS FOR REFERENCE.-
BR 460

ISSUE 1 DATE SEP' 80
 (visit <http://www.barrowmoremrg.co.uk>)

EH 273

BRAKES
BOGIE/SUSPENSION
BODY CONSTRUCTION
COUPLINGS
TRAIN HEATING
MAX. SPEED M.P.H.
MIN. RAD. CURVE CHAINS
LIGHTING
TARE WEIGHT TONNES
GANGWAYS
TRAIN COMMUNICATION
BUFFERS
S.R. DESIGN REFERENCE CODE

BASIC TYPE

ELECTRO PNEUMATIC
S.R. MK 4 UNPOWERED
STEEL
AUTOMATIC SOLID SHANK (ALLIANCE NO. 2)
ELECTRIC (BR)
90
3.5
ELECTRIC
31.5
EXPRESS ELECTRIC
NOT FITTED
NOT FITTED
BK

ALTERNATIVES

COMMONWEALTH

BN

TRACTION DATA FOR MULTIPLE UNITS

EMU- INTRODUCED 1958.
VOLTAGE 750/850 VOLTS D.C. THIRD RAIL

BASIC TYPE

EH 273 0A

VARIANTS

1B COMMONWEALTH BOGIES, S.R. DESIGN REFERENCE CODE BN.

TRAILER SECOND

CLASS 411/2

TS

EH 274

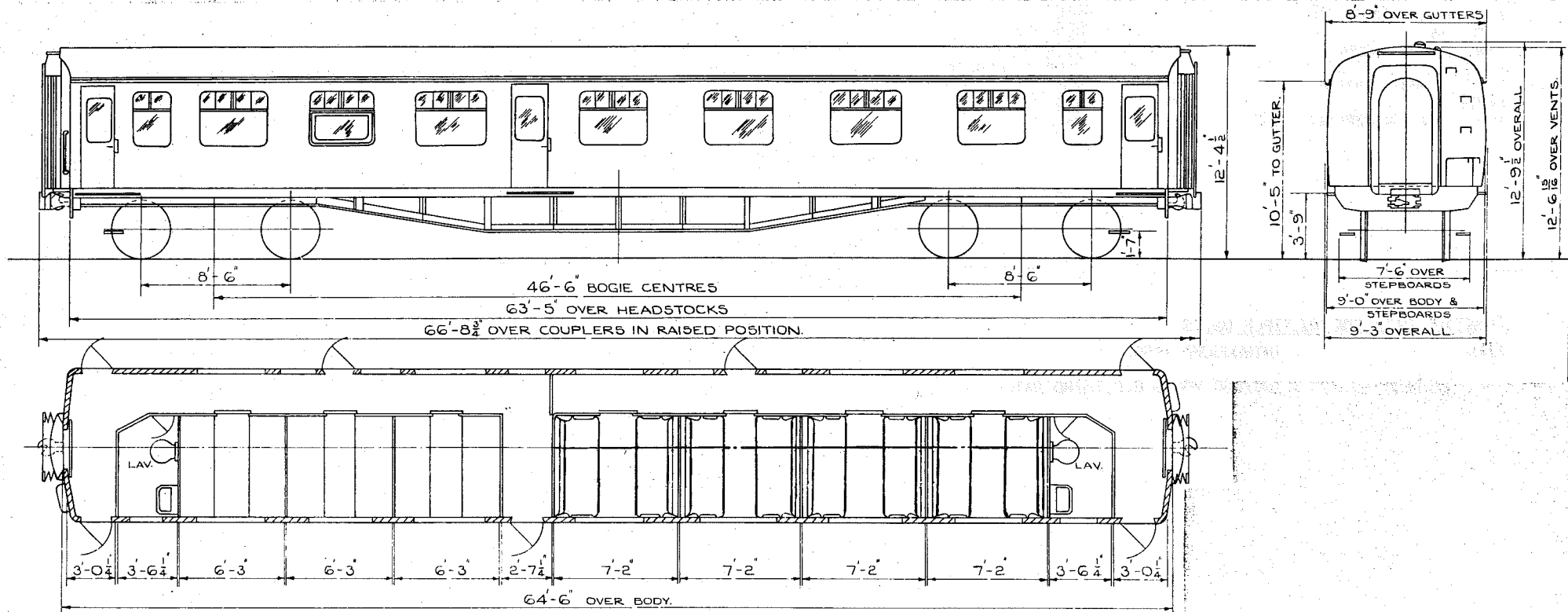

SEATS	56
TOILETS	2
COMPARTMENTS	7
GUARDS COMPARTMENTS	-
VENTILATION	-
CATERING EQUIPMENT	-

ORIGINAL DIAGRAMS FOR REFERENCE.-
BR 450

ISSUE 1 DATE SEP' 80

EH 274

BRAKES
BOGIE/SUSPENSION
BODY CONSTRUCTION
COUPLINGS
TRAIN HEATING
MAX. SPEED M.P.H.
MIN. RAD. CURVE CHAINS
LIGHTING
TARE WEIGHT TONNES
GANGWAYS
TRAIN COMMUNICATION
BUFFERS
S.R. DESIGN REFERENCE CODE

BASIC TYPE

ELECTRO PNEUMATIC
COMMONWEALTH
STEEL
AUTOMATIC SOLID SHANK (ALLIANCE NO.2)
ELECTRIC (BR)
90
3.5
ELECTRIC
31.5
EXPRESS ELECTRIC
NOT FITTED
NOT FITTED
BM 2B

ALTERNATIVES

TRACTION DATA FOR MULTIPLE UNITS

EMU- INTRODUCED 1958.
VOLTAGE 750/850 VOLTS D.C. THIRD RAIL

BASIC TYPE

EH 274 0A

VARIANTS

NONE

TRAILER SECOND

CLASS 421/1
421/2

TS

EH 275

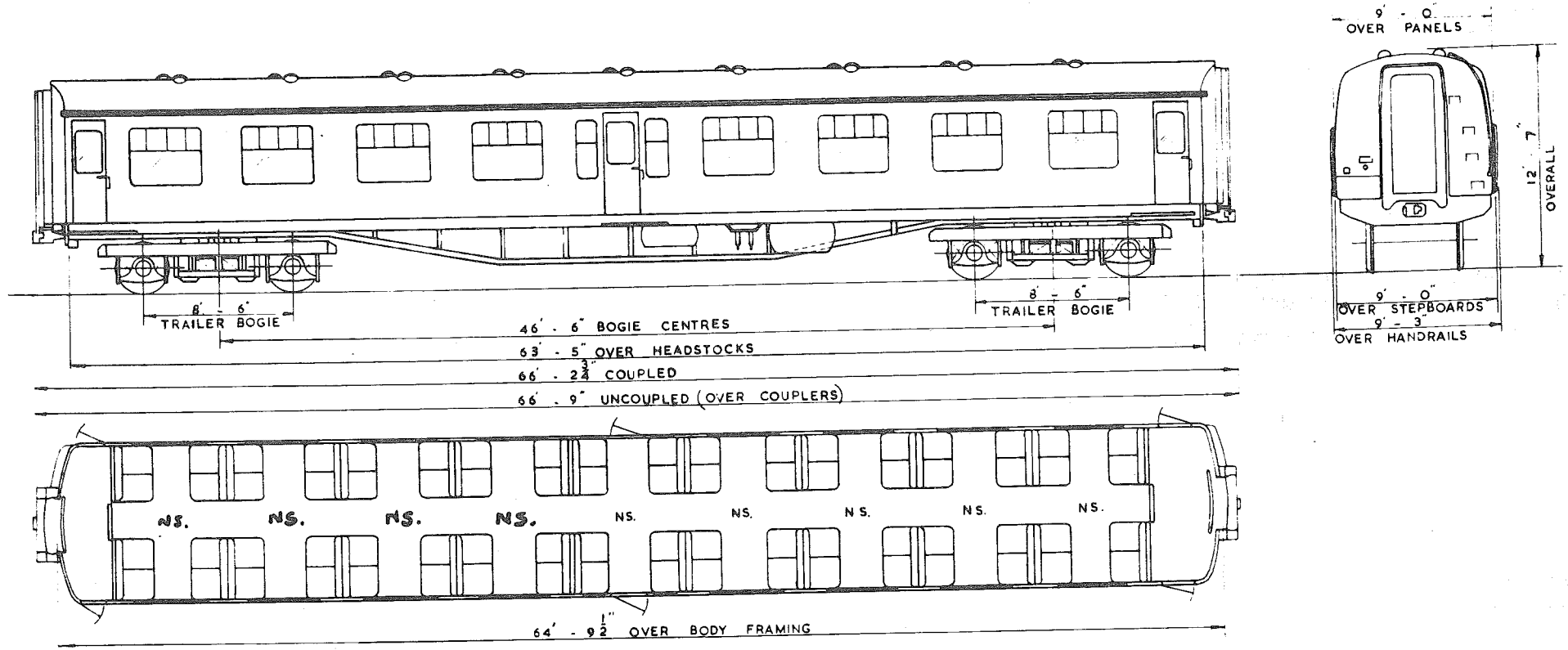

SEATS	72
TOILETS	-
COMPARTMENTS	-
GUARDS COMPARTMENTS	-
VENTILATION	-
CATERING EQUIPMENT	-

ORIGINAL DIAGRAMS FOR REFERENCE:-
BR 472

ISSUE	DATE
2	NOV '84

EH 275

BASIC TYPE

BRAKES
BOGIE/SUSPENSION
BODY CONSTRUCTION
COUPLINGS
TRAIN HEATING
MAX.SPEED M.P.H.
MIN.RAD.CURVE CHAINS
LIGHTING
TARE WEIGHT TONNES
GANGWAYS
TRAIN COMMUNICATION
BUFFERS
S.R.DESIGN REFERENCE CODE

ELECTRO PNEUMATIC
B5(S.R.)
STEEL
AUTOMATIC SOLID SHANK(ALLIANCE NO.2)
ELECTRIC(BR)
90
3.5
TUNGSTEN
31.5
EXPRESS ELECTRIC
NOT FITTED
NOT FITTED
B0

ALTERNATIVES

B0 1A

TRACTION DATA FOR MULTIPLE UNITS

EMU- INTRODUCED-CLASS 421/1 1964-CLASS 421/2 1970.
VOLTAGE 750/850 VOLTS D.C.THIRD RAIL

BASIC TYPE

EH 275 0A

VARIANTS

1B S.R.DESIGN REFERENCE CODE B0 1A.

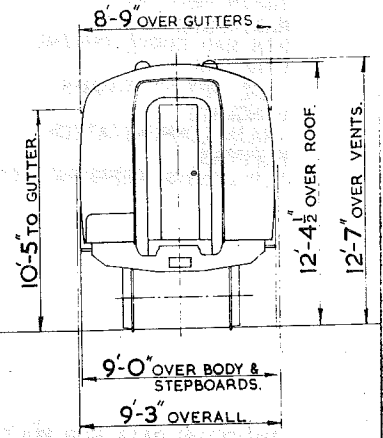
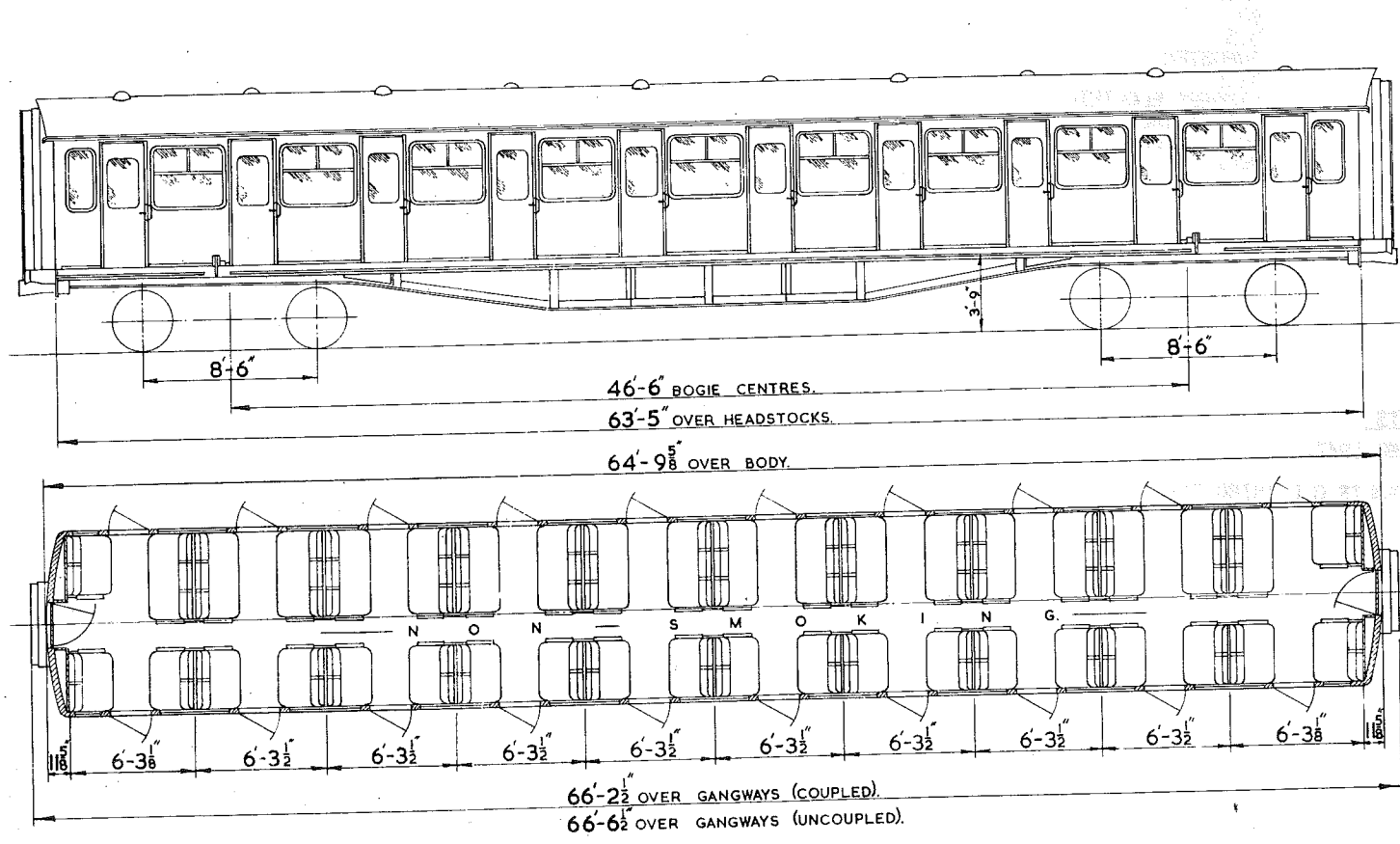

SEATS	98
TOILETS	-
COMPARTMENTS	-
GUARDS COMPARTMENTS	-
VENTILATION	-
CATERING EQUIPMENT	-

ORIGINAL DIAGRAMS FOR REFERENCE. -
BR 474

ISSUE 2 DATE MAY '81

EH 276

BASIC TYPE

BRAKES
BOGIE/SUSPENSION
BODY CONSTRUCTION
COUPLINGS
TRAIN HEATING
MAX. SPEED M.P.H.
MIN. RAD. CURVE CHAINS
LIGHTING
TARE WEIGHT TONNES
GANGWAYS
TRAIN COMMUNICATION
BUFFERS
S.R. DESIGN REFERENCE CODE

ELECTRO PNEUMATIC
B5 (S.R.)
STEEL
AUTOMATIC SOLID SHANK (ALLIANCE NO.2)
ELECTRIC (BR)
90
3.5
TUNGSTEN
31.5
EXPRESS ELECTRIC
NOT FITTED
NOT FITTED
BQ-L

ALTERNATIVES

TRACTION DATA FOR MULTIPLE UNITS

EMU- INTRODUCED 1967.
VOLTAGE 750/850 VOLTS D.C. THIRD RAIL

BASIC TYPE

EH 276 0A

VARIANTS

NONE

TRAILER SECOND

CLASS 411/3

TS

EH 277

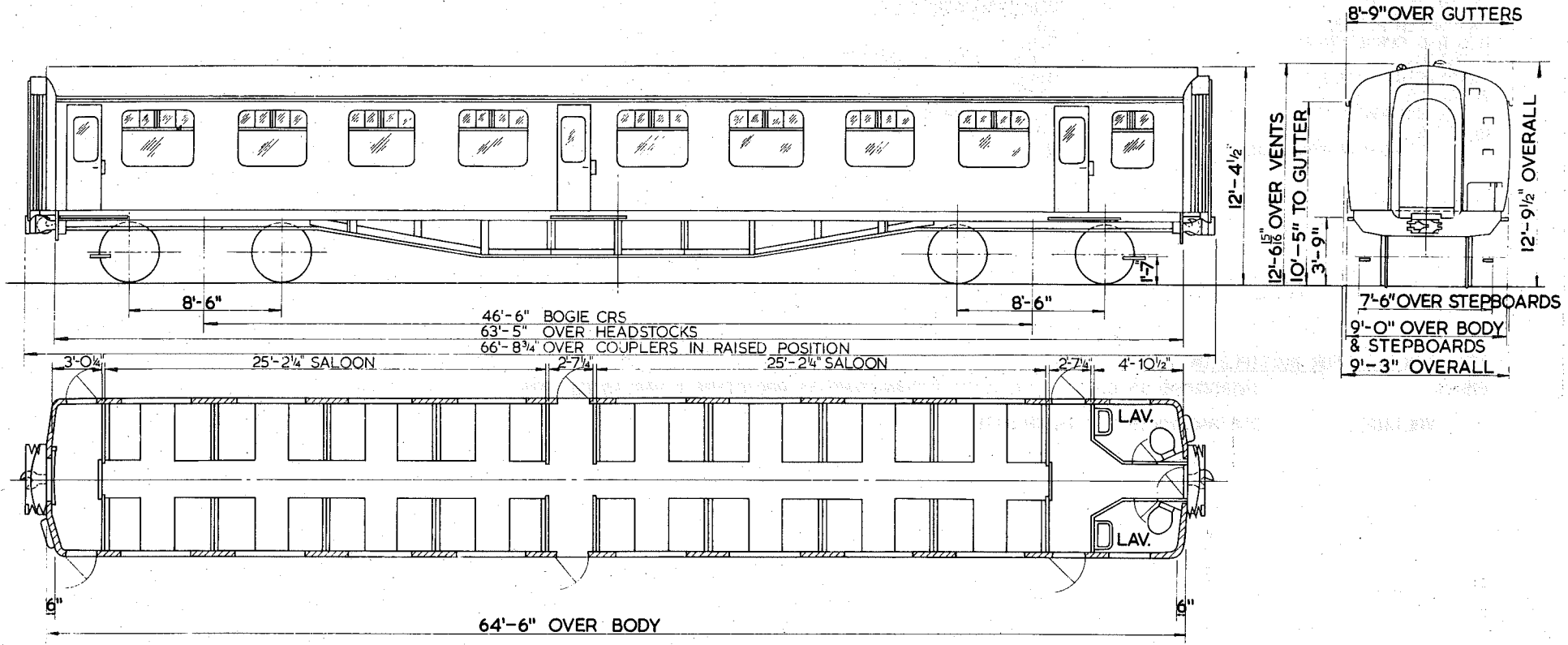

SEATS	64
TOILETS	2
COMPARTMENTS	-
GUARDS COMPARTMENTS	-
VENTILATION	-
CATERING EQUIPMENT	-

ORIGINAL DIAGRAMS FOR REFERENCE.-
BR 901

ISSUE 1 DATE SEP '80

EH 277

BASIC TYPE

ALTERNATIVES

BRAKES
BOGIE/SUSPENSION
BODY CONSTRUCTION
COUPLINGS
TRAIN HEATING
MAX. SPEED M.P.H.
MIN. RAD. CURVE CHAINS
LIGHTING
TARE WEIGHT TONNES
GANGWAYS
TRAIN COMMUNICATION
BUFFERS
S.R. DESIGN REFERENCE CODE

ELECTRO PNEUMATIC
COMMONWEALTH
STEEL
AUTOMATIC SOLID SHANK (ALLIANCE NO.2)
ELECTRIC (BR)
90
3.5
FLUORESCENT & TUNGSTEN
31.5
EXPRESS ELECTRIC
PUBLIC ADDRESS
NOT FITTED
BX

TRACTION DATA FOR MULTIPLE UNITS

EMU- INTRODUCED AS CLASS 411/2 1958-REFURBISHED AS PROTOTYPE & RECLASSED 1975.
VOLTAGE 750/850 VOLTS D.C. THIRD RAIL

BASIC TYPE

EH 277 0A

VARIANTS

NONE

TRAILER SECOND

CLASS 423/1

TS

EH 278

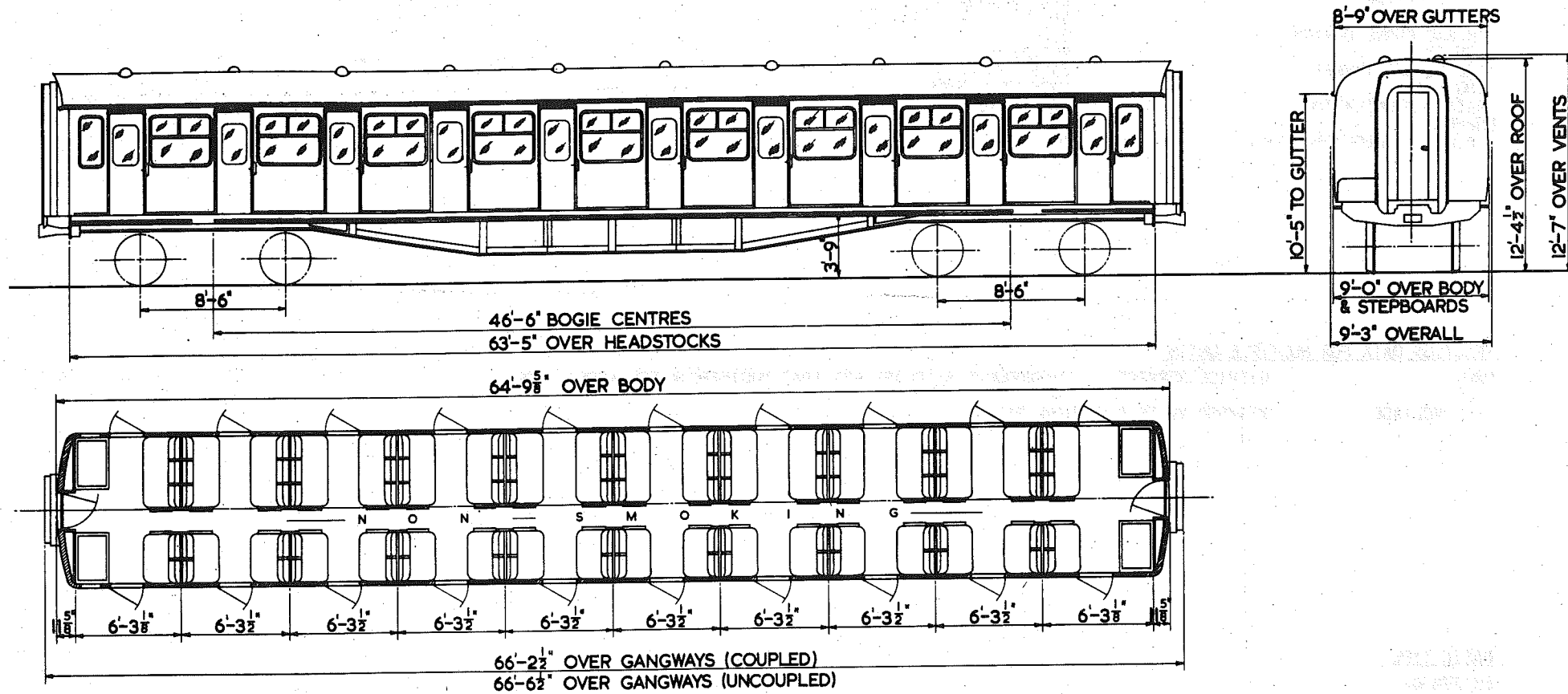

SEATS	90
TOILETS	-
COMPARTMENTS	-
GUARDS COMPARTMENTS	-
VENTILATION	-
CATERING EQUIPMENT	-

ORIGINAL DIAGRAMS FOR REFERENCE, -
BR 842

ISSUE 1 DATE SEP' 80

EH 278

BASIC TYPE

BRAKES
BOGIE/SUSPENSION
BODY CONSTRUCTION
COUPLINGS
TRAIN HEATING
MAX. SPEED M.P.H.
MIN. RAD. CURVE CHAINS
LIGHTING
TARE WEIGHT TONNES
GANGWAYS
TRAIN COMMUNICATION
BUFFERS
S.R. DESIGN REFERENCE CODE

ELECTRO PNEUMATIC
B5 (S.R.)
STEEL
AUTOMATIC SOLID SHANK (ALLIANCE NO.2)
ELECTRIC (BR)
90
3.5
ELECTRIC
31.5
EXPRESS ELECTRIC
NOT FITTED
NOT FITTED
BQ

ALTERNATIVES

TRACTION DATA FOR MULTIPLE UNITS

EMU- GATWICK SERVICE. INTRODUCED AS CLASS 423 1967-MODIFIED & RECLASSED 1978.
VOLTAGE 750/850 VOLTS D.C. THIRD RAIL

BASIC TYPE

EH 278 0A

VARIANTS

NONE

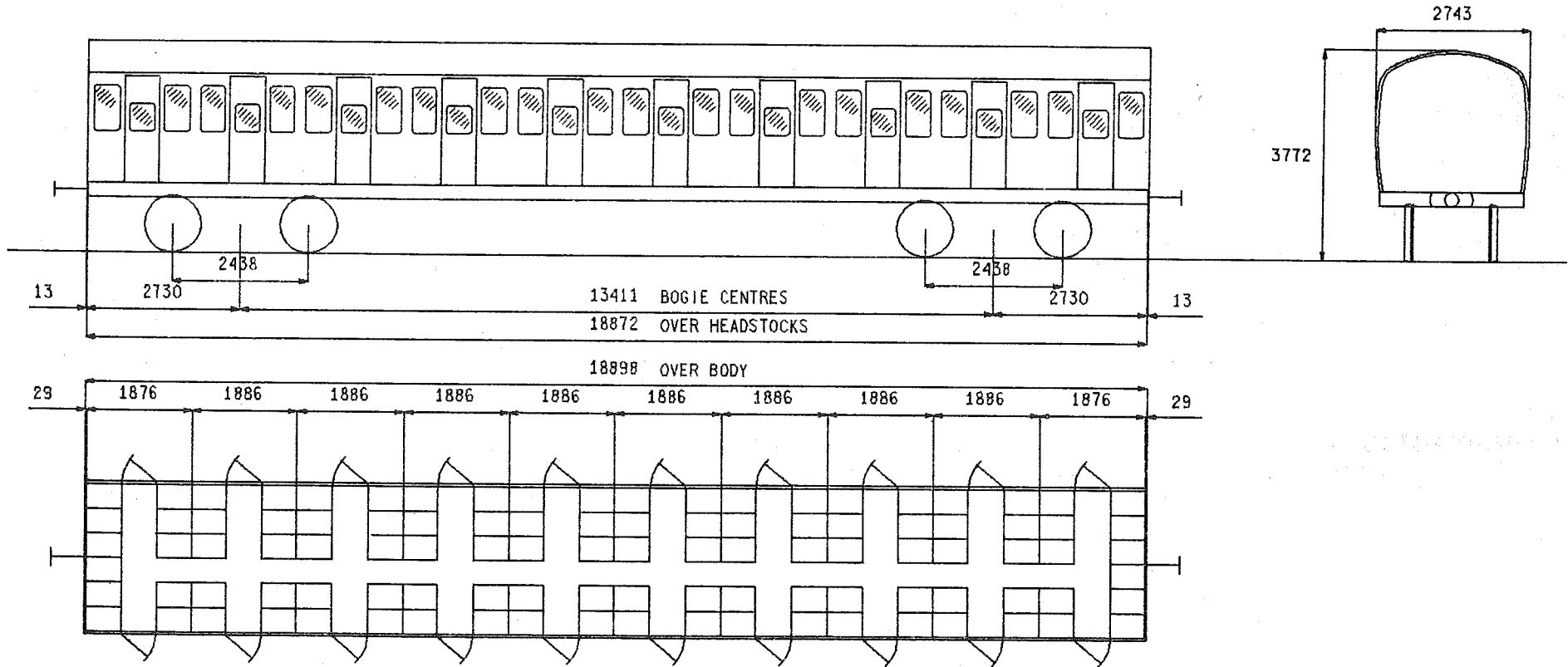

SEATS	102
TOILETS	-
COMPARTMENTS	-
GUARDS COMPARTMENTS	-
VENTILATION	-
CATERING EQUIPMENT	-

ISSUE 3 DATE JAN 84

EH 279

BRAKES
BOGIE/SUSPENSION
BODY CONSTRUCTION
COUPLINGS
TRAIN HEATING
MAX.SPEED M.P.H.
MIN.RAD.CURVE CHAINS
LIGHTING
TARE WEIGHT TONNES
GANGWAYS
A.W.S.
TRAIN COMMUNICATION
BUFFERS
S.R.DESIGN REFERENCE CODE
SMOKING ACCOMMODATION

BASIC TYPE

ELECTRO PNEUMATIC
S.R.STANDARD-229X114
STEEL
3 LINK
ELECTRIC(BR)
75
3.5
FLUORESCENT & TUNGSTEN
26
NOT FITTED
NOT FITTED
PUBLIC ADDRESS
CENTRE BOTH ENDS
DAK 1B
NON SMOKING

ALTERNATIVES

SMOKING

TRACTION DATA FOR MULTIPLE UNITS

EMU- INTRODUCED AS CLASS 405 1946, MODIFIED, REFURBISHED & RE-CLASSIFIED AS 415/1 1980/81, RECLASSIFIED 1984.
VOLTAGE 750/850 VOLTS D.C. THIRD RAIL

BASIC TYPE

EH 279 0A

VARIANTS

OB ALL SMOKING ACCOMMODATION.

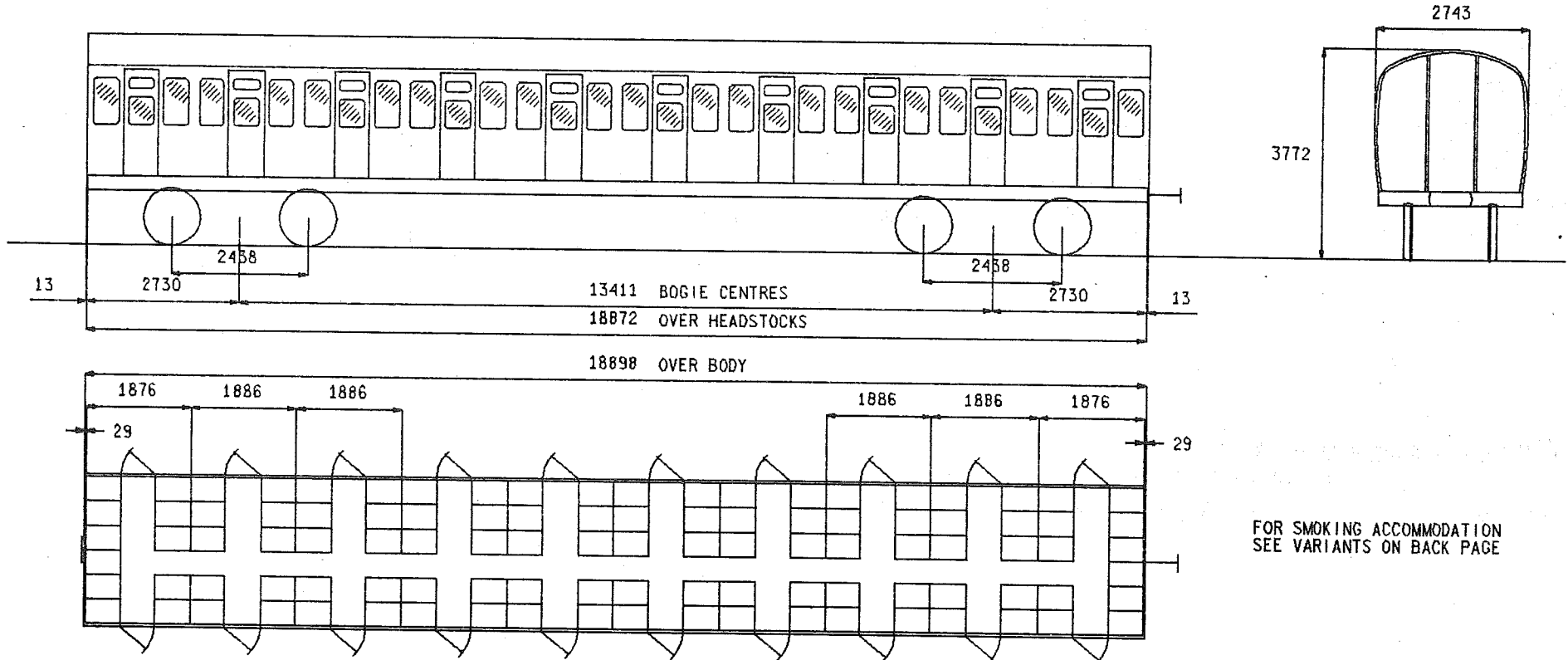

FOR SMOKING ACCOMMODATION
SEE VARIANTS ON BACK PAGE

SEATS	102
TOILETS	-
COMPARTMENTS	-
GUARDS COMPARTMENTS	-
VENTILATION	-
CATERING EQUIPMENT	-

ISSUE 3 DATE JAN 84

EH 280

BASIC TYPE

BRAKES
BOGIE/SUSPENSION
BODY CONSTRUCTION
COUPLINGS
TRAIN HEATING
MAX.SPEED M.P.H.
MIN.RAD.CURVE CHAINS
LIGHTING
TARE WEIGHT TONNES
GANGWAYS
TRAIN COMMUNICATION
BUFFERS
S.R.DESIGN REFERENCE CODE
SMOKING ACCOMMODATION

ELECTRO PNEUMATIC
S.R.STANDARD 229 X 114
STEEL
THREE LINK
ELECTRIC(BR)
75
3.5
FLUORESCENT
28
NOT FITTED
PUBLIC ADDRESS
CENTRE ONE END-CENTRE WEARING PLATE OTHER END
DU
NONE

ALTERNATIVES

DAK 1B
ALL SMOKING

TRACTION DATA FOR MULTIPLE UNITS

EMU- INTRODUCED 1951-REFURBISHED 1979/80,RECLASSED 1984.
VOLTAGE 750/850 VOLTS D.C.THIRD RAIL

BASIC TYPE

EH 280 0A-REFURBISHED

VARIANTS

0B REFURBISHED-ALL SMOKING ACCOMMODATION.
1B REFURBISHED-S.R.DESIGN REFERENCE CODE DAK 1B.
1C REFURBISHED-S.R.DESIGN REFERENCE DAK 1B,ALL SMOKING ACCOMMODATION.

TRAILER SECOND

CLASS 415/4

TS

EH 281

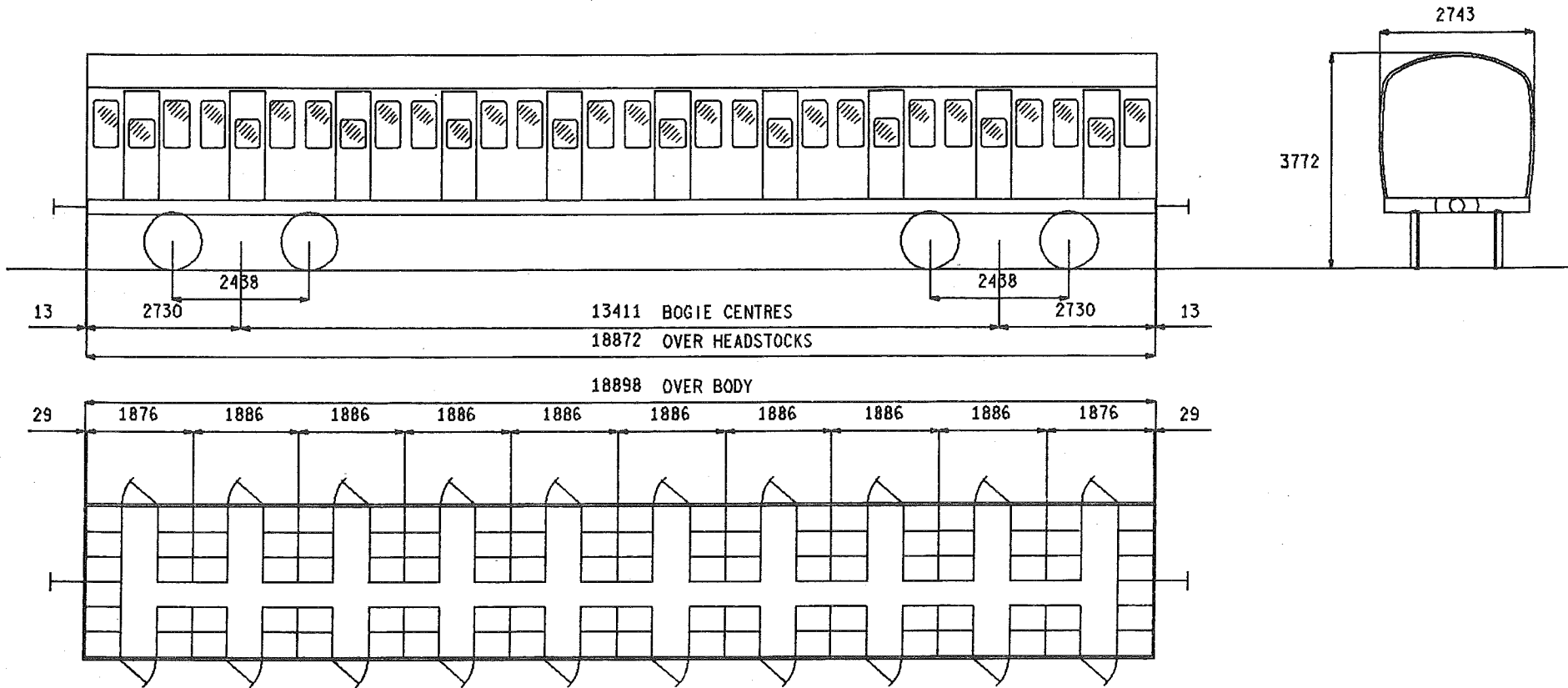

SEATS	102
TOILETS	-
COMPARTMENTS	-
GUARDS COMPARTMENTS	-
VENTILATION	-
CATERING EQUIPMENT	-

ISSUE	DATE
7	MAR 86

EH 281

BASIC TYPE

BRAKES
BOGIE/SUSPENSION
BODY CONSTRUCTION
COUPLINGS
TRAIN HEATING
MAX.SPEED M.P.H.
MIN.RAD.CURVE CHAINS
LIGHTING
TARE WEIGHT TONNES
GANGWAYS
TRAIN COMMUNICATION
BUFFERS
S.R.DESIGN REFERENCE CODE
SMOKING ACCOMMODATION

ELECTRO PNEUMATIC
S.R.STANDARD 229 X 114
STEEL
THREE LINK
ELECTRIC(BR)
75
3.5
FLUORESCENT
27
NOT FITTED
PUBLIC ADDRESS
CENTRE
DAK 1A
SMOKING

ALTERNATIVES

DAH,DAK-2A
NON SMOKING

TRACTION DATA FOR MULTIPLE UNITS

EMU- INTRODUCED 1951-REFURBISHED 1979/80,RECLASSIFIED 1984.
VOLTAGE 750/850 VOLTS D.C.THIRD RAIL

BASIC TYPE

EH 281 0A-REFURBISHED

VARIANTS

1A S.R.DESIGN REF.CODE DAK-2A.
1C S.R.DESIGN REF.CODE DAK-2A,NON SMOKING.
2B PROTOTYPE REFURBISHED,S.R.DESIGN REF.CODE DAH.
2D PROTOTYPE REFURBISHED,S.R.DESIGN REF.CODE DAH,NON SMOKING.

TRAILER SECOND

CLASS 411/5

TS

EH 282

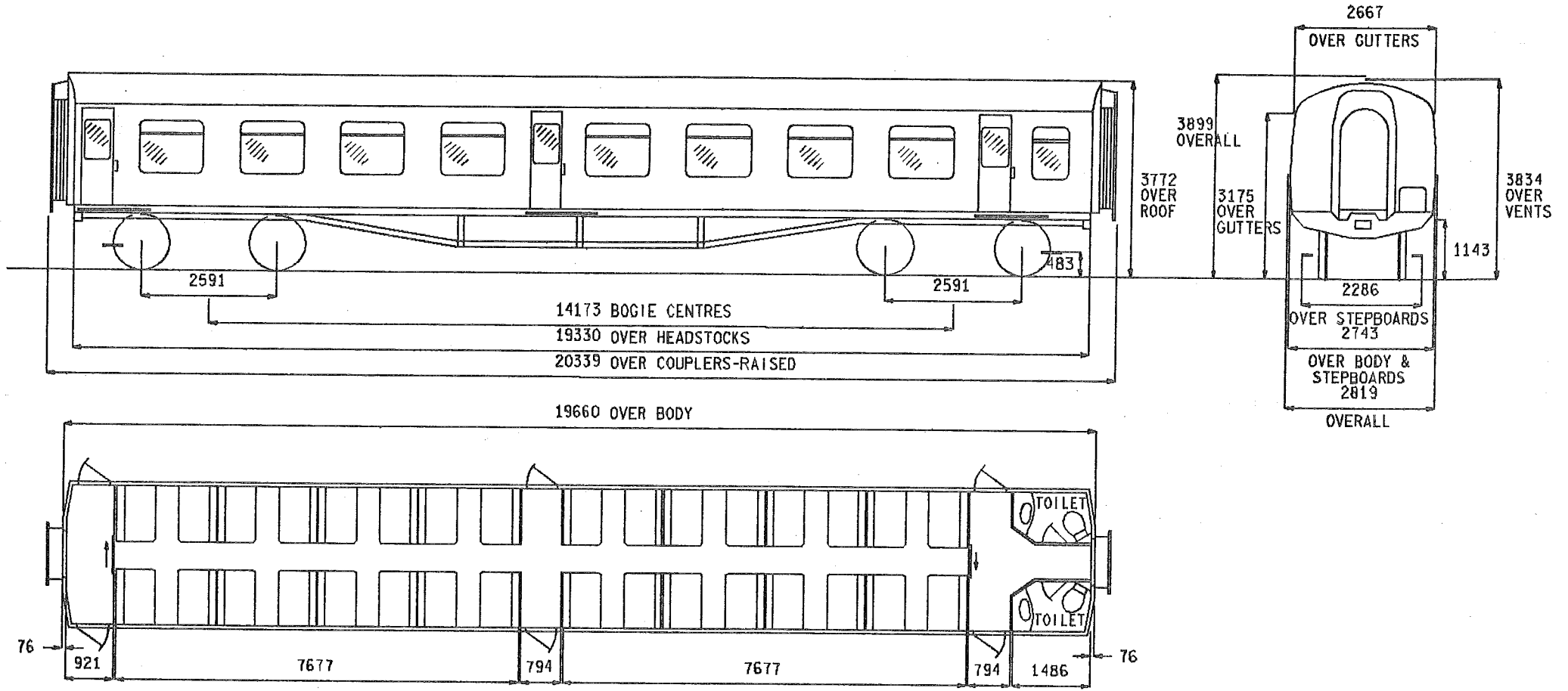

SEATS	64
TOILETS	2
COMPARTMENTS	-
GUARDS COMPARTMENTS	-
VENTILATION	-
CATERING EQUIPMENT	-

ORIGINAL DIAGRAMS FOR REFERENCE:-
BR 903

ISSUE 3 DATE APR '83

EH 282

BASIC TYPE

ALTERNATIVES

BRAKES
BOGIE/SUSPENSION
BODY CONSTRUCTION
COUPLINGS
TRAIN HEATING
MAX.SPEED M.P.H.
MIN.RAD.CURVE CHAINS
LIGHTING
TARE WEIGHT TONNES
GANGWAYS
TRAIN COMMUNICATION
BUFFERS
S.R.DESIGN REFERENCE CODE

ELECTRO PNEUMATIC
COMMONWEALTH
STEEL
AUTOMATIC SOLID SHANK (ALLIANCE NO.2)
ELECTRIC (BR)
90
3.5
FLUORESCENT & TUNGSTEN
31.5
EXPRESS ELECTRIC
PUBLIC ADDRESS
NOT FITTED
BZ

BX, BX 1A, BW 2C

TRACTION DATA FOR MULTIPLE UNITS

EMU- INTRODUCED 1958-REFURBISHED 1980, RECLASSIFIED 1983.
VOLTAGE 750/850 VOLTS D.C. THIRD RAIL

BASIC TYPE

EH 202 0A-REFURBISHED

VARIANTS

- 1A REFURBISHED-S.R.DESIGN REFERENCE CODE BX.
- 2A REFURBISHED-S.R.DESIGN REFERENCE CODE BX 1A.
- 3A REFURBISHED-S.R.DESIGN REFERENCE CODE BW 2C.

TRAILER SECOND

CLASS 423

TS

EH 283

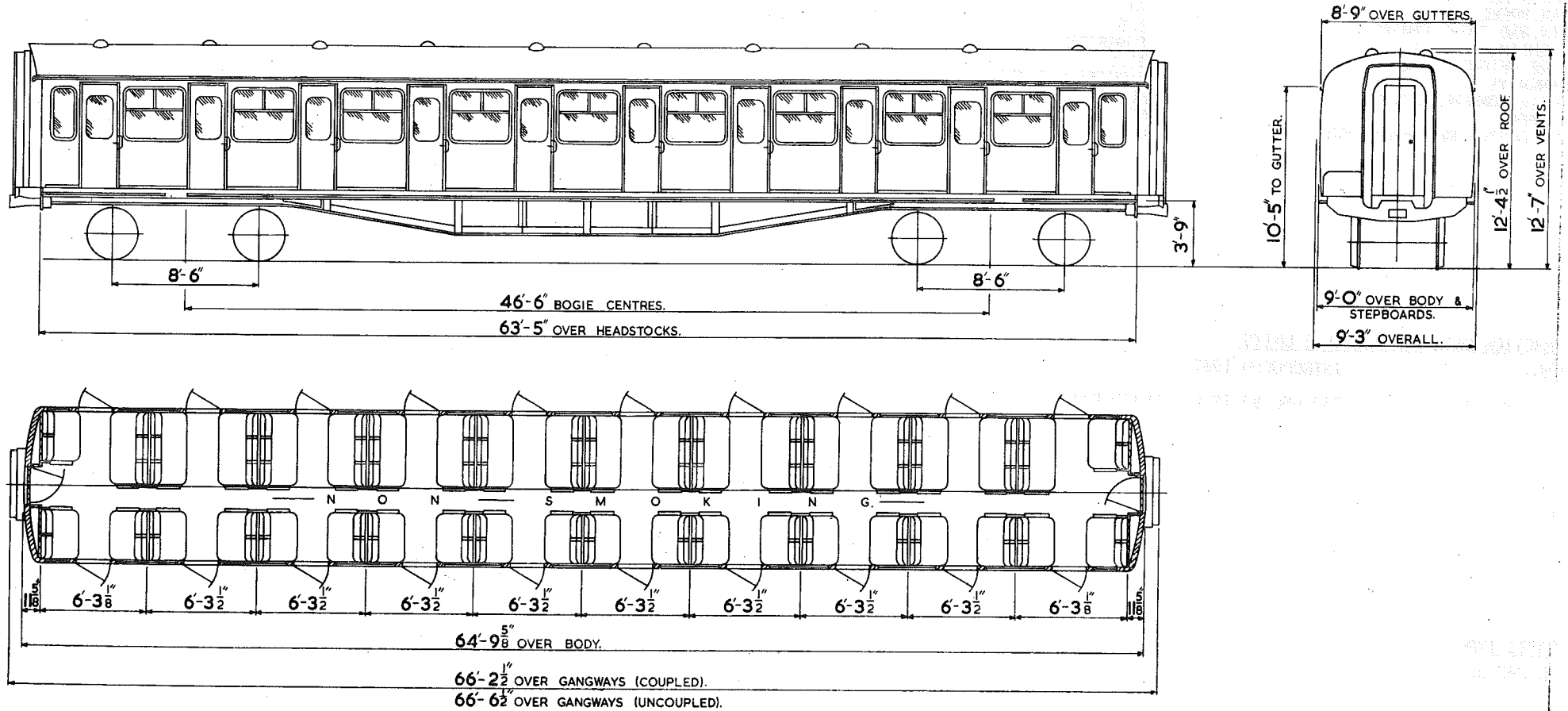

SEATS	98
TOILETS	-
COMPARTMENTS	-
GUARDS COMPARTMENTS	-
VENTILATION	-
CATERING EQUIPMENT	-

ORIGINAL DIAGRAMS FOR REFERENCE.-
BR 475

ISSUE 2 DATE MAY '81

EH 283

BRAKES
BOGIE/SUSPENSION
BODY CONSTRUCTION
COUPLINGS
TRAIN HEATING
MAX. SPEED M.P.H.
MIN. RAD. CURVE CHAINS
LIGHTING
TARE WEIGHT TONNES
GANGWAYS
TRAIN COMMUNICATION
BUFFERS
S.R. DESIGN REFERENCE CODE

BASIC TYPE

ELECTRO PNEUMATIC
B5 (S.R.)
STEEL
AUTOMATIC SOLID SHANK (ALLIANCE NO.2)
ELECTRIC (BR)
90
3.5
TUNGSTEN
31.5
EXPRESS ELECTRIC
NOT FITTED
NOT FITTED
BQ

ALTERNATIVES

TRACTION DATA FOR MULTIPLE UNITS

EMU- INTRODUCED 1967.
VOLTAGE 750/850 VOLTS D.C. THIRD RAIL

BASIC TYPE

EH 283 0A

VARIANTS

NONE

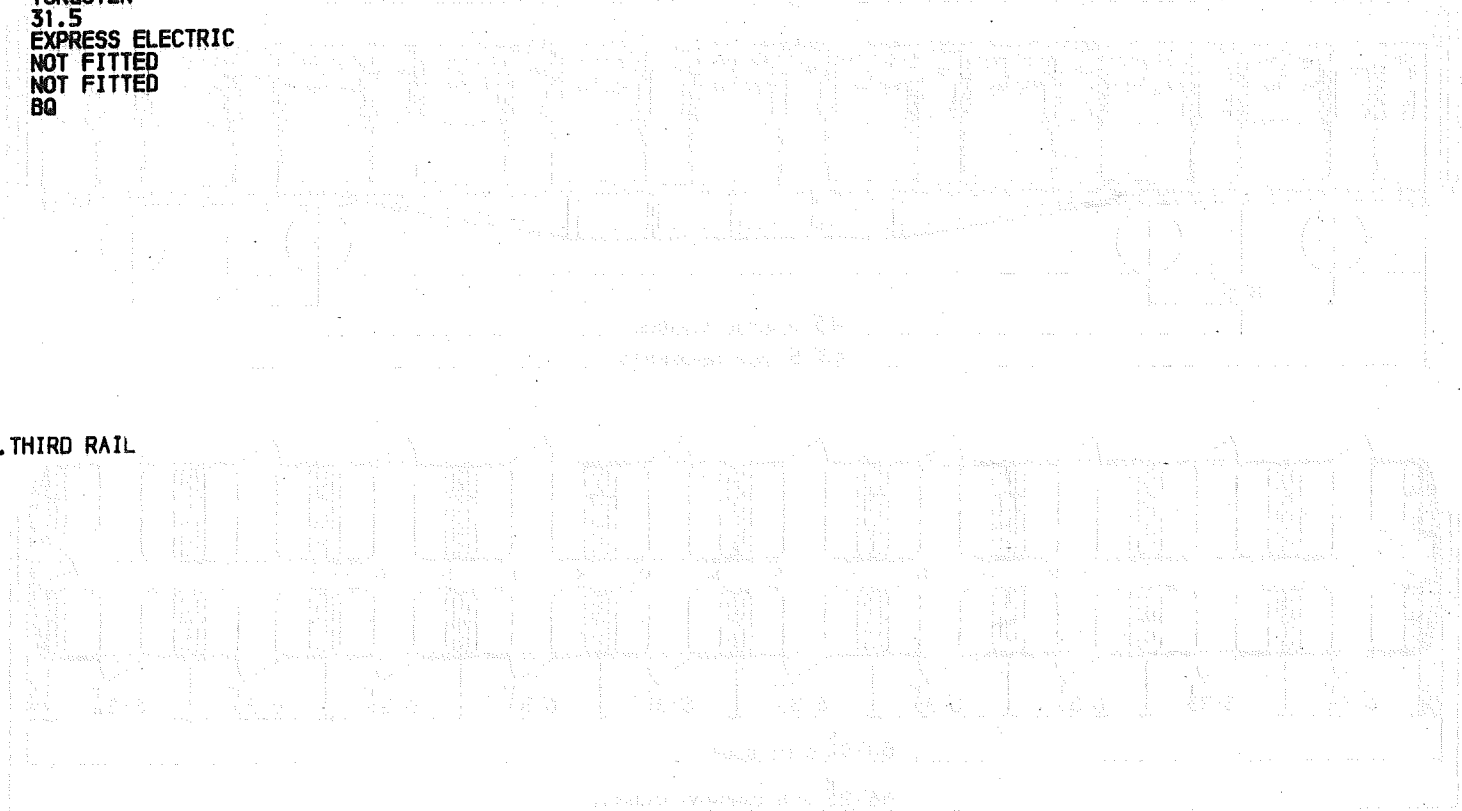

BRITISH RAILWAYS
BRITISH RAILWAYS
BRITISH RAILWAYS
BRITISH RAILWAYS
BRITISH RAILWAYS

TRAILER SECOND

CLASS 411/5

TS

EH 284

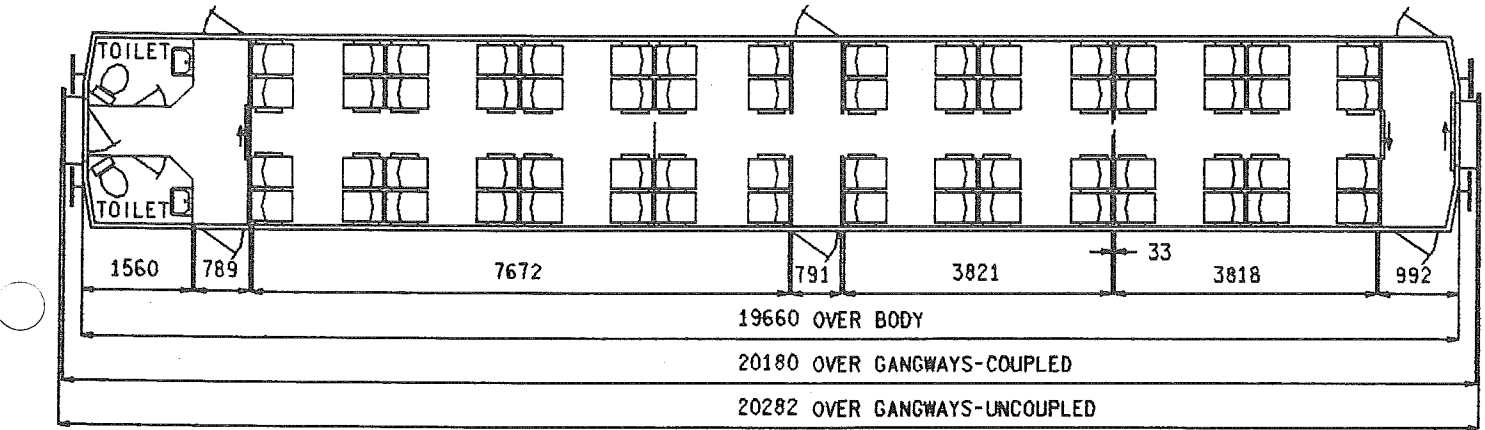
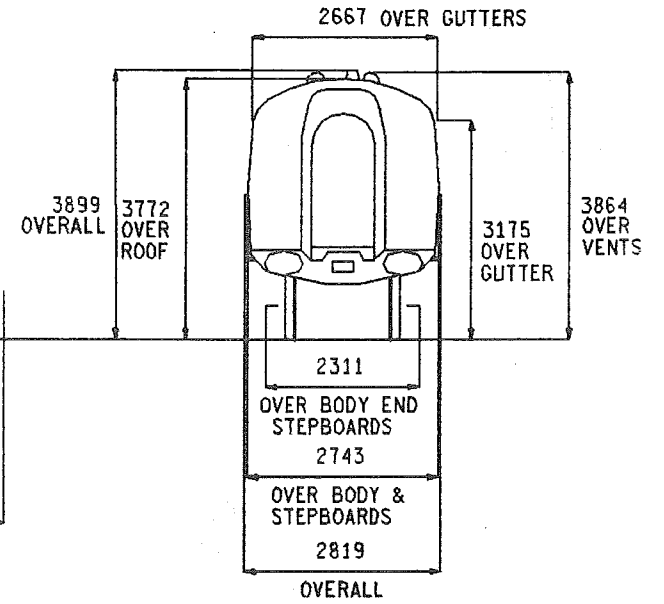
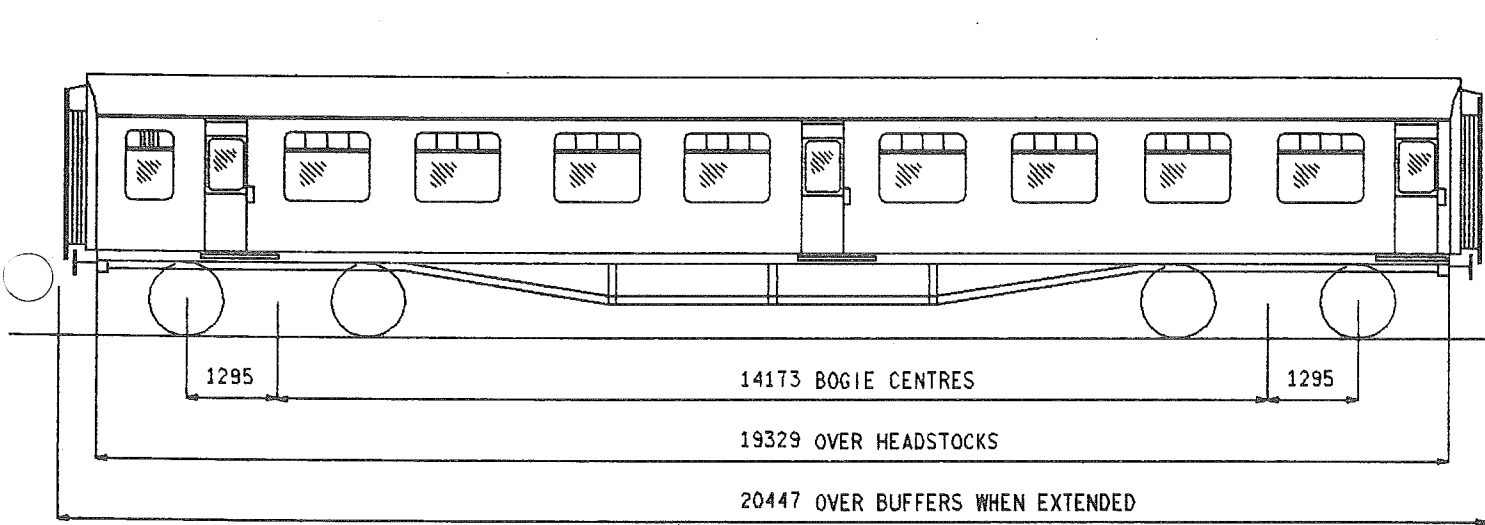

SEATS	64
TOILETS	2
COMPARTMENTS	-
GUARDS COMPARTMENTS	-
VENTILATION	-
CATERING EQUIPMENT	-

ISSUE 3 DATE NOV '84

EH 284

BASIC TYPE

ALTERNATIVES

BRAKES
BOGIE/SUSPENSION
BODY CONSTRUCTION
COUPLINGS
TRAIN HEATING
MAX.SPEED M.P.H.
MIN.RAD.CURVE CHAINS
LIGHTING
TARE WEIGHT TONNES
GANGWAYS
A.W.S.
TRAIN COMMUNICATION
BUFFERS
S.R.DESIGN REFERENCE CODE

ELECTRO PNEUMATIC
COMMONWEALTH
STEEL
AUTOMATIC SOLID SHANK(ALLIANCE NO.2)
ELECTRIC(BR)
90
3.5
FLUOESCENT & TUNGSTEN
33.5
EXPRESS ELECTRIC
NOT FITTED
PUBLIC ADDRESS
NOT FITTED
BX4E

TRACTION DATA FOR MULTIPLE UNITS

EMU- INTRODUCED 1954 AS MK 1 LOCO-HAULED,REFURBISHED AS CLASS 411/1 & 411/2-1981/2,RECLASSIFIED 411/5 1983
VOLTAGE 750/850 VOLTS D.C.THIRD RAIL

BASIC TYPE

EH 284-REFURBISHED

VARIANTS

NONE

TRAILER SECOND

CLASS 488/3

TS

EH 285

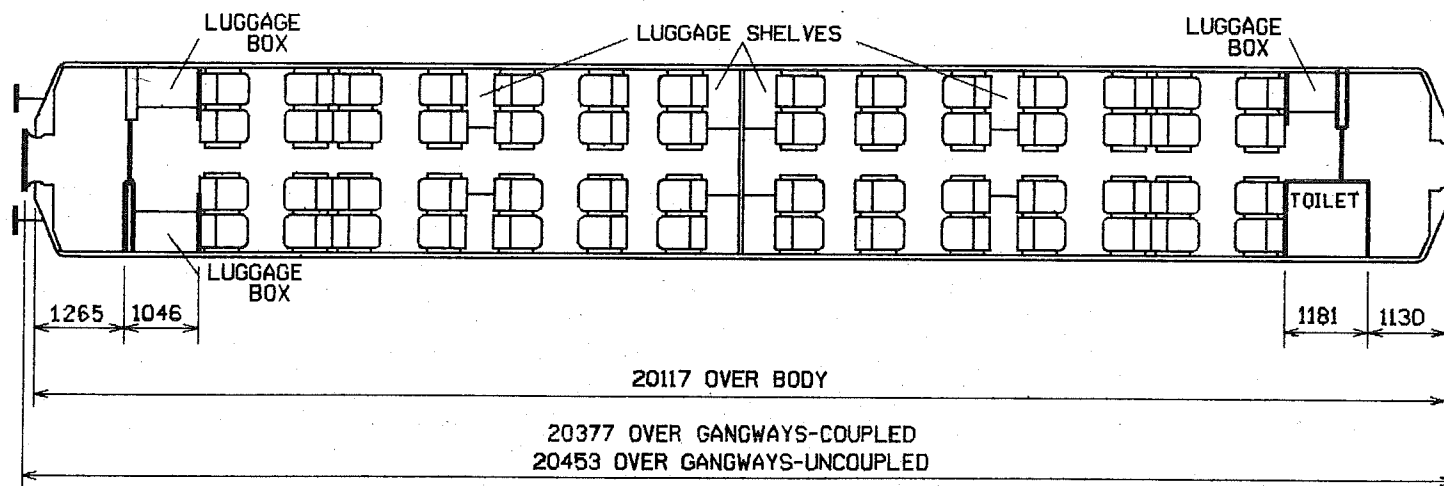
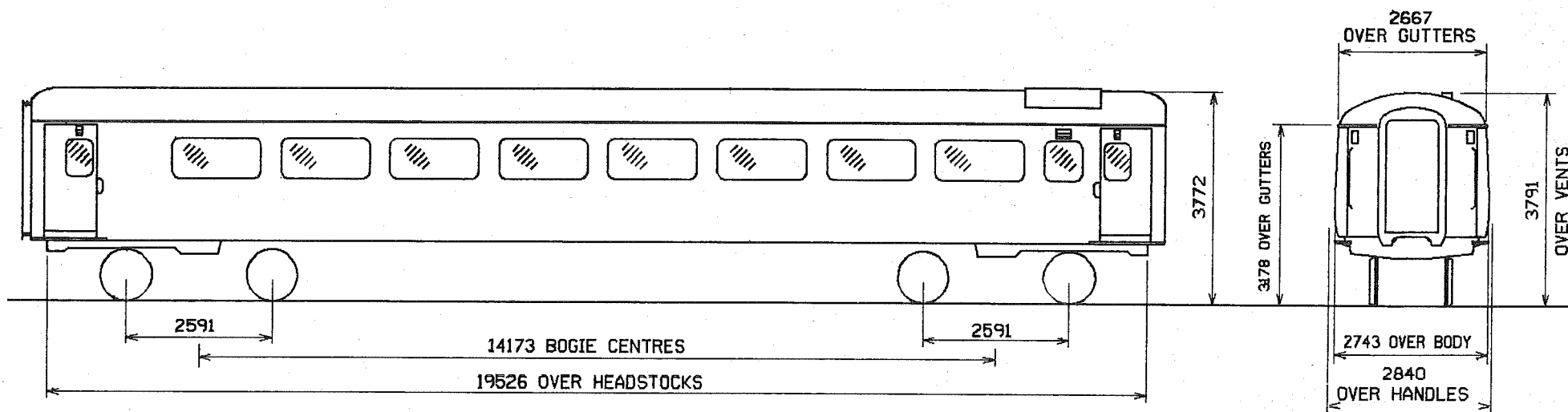

SEATS	56
TOILETS	1
COMPARTMENTS	-
GUARDS COMPARTMENTS	-
VENTILATION	FULL AIR CONDITIONING
CATERING EQUIPMENT	-

ISSUE 1 DATE AUG'83

EH 285

BRAKES
BOGIE/SUSPENSION
BODY CONSTRUCTION
COUPLINGS
TRAIN HEATING
MAX SPEED M.P.H.
MIN.RAD.CURVE CHAINS
LIGHTING
TARE WEIGHT TONNES
GANGWAYS
TRAIN COMMUNICATION
BUFFERS

BASIC TYPE

ELECTRO PNEUMATIC
B4
STEEL
BAR
ELECTRIC(BR)FULL AIR CONDITIONING
90
3.5
FLUORESCENT & TUNGSTEN
35(ESTIMATED)
PULLMAN
PUBLIC ADDRESS
NOT FITTED

ALTERNATIVES

TRACTION DATA FOR MULTIPLE UNITS

EMU- VICTORIA-GATWICK CONVERTED MK IIF TO BE INTRODUCED.
VOLTAGE 750 VOLTS D.C.THIRD RAIL

BASIC TYPE

EH 285 0A

VARIANTS

NONE

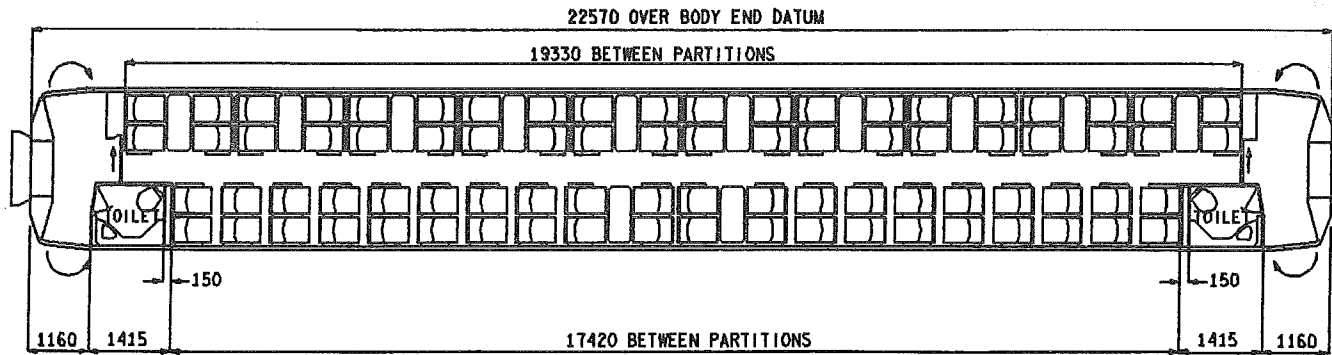
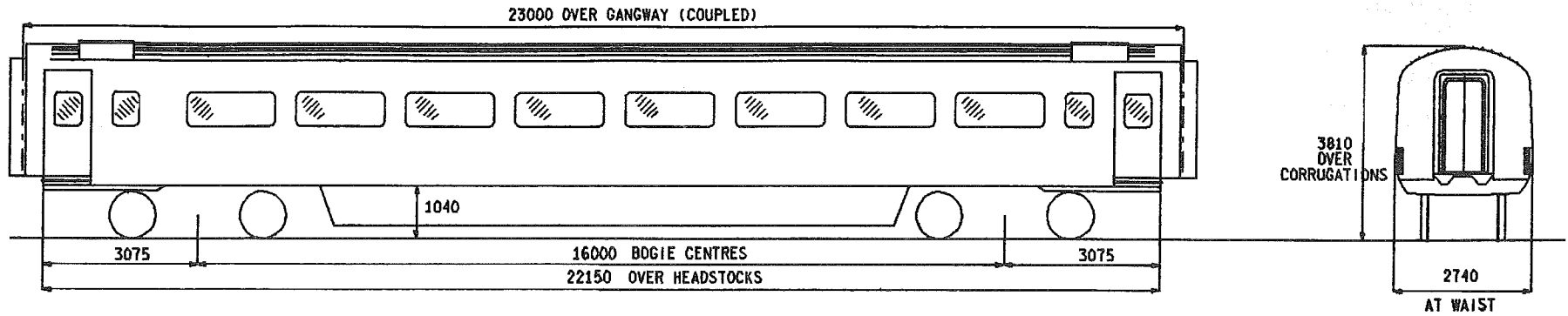

- | | |
|---------------------|-----------------------|
| SEATS | 80 |
| TOILETS | 2 |
| COMPARTMENTS | - |
| GUARDS COMPARTMENTS | - |
| VENTILATION | FULL AIR CONDITIONING |
| CATERING EQUIPMENT | - |

ISSUE 1 DATE JUL 88

EH 288

BRAKES
BOGIE/SUSPENSION
BODY CONSTRUCTION
COUPLINGS
TRAIN HEATING
E.T.H. INDEX
MAX. SPEED M.P.H.
MIN. RAD. CURVE METRES
LIGHTING
TARE WEIGHT TONNES
GANGWAYS
TRAIN COMMUNICATION
BUFFERS

BASIC TYPE

ELECTRO-PNEUMATIC
T3-7 (BREL)
STEEL
BAR
ELECTRIC(BR)FULL AIR CONDITIONING
—
100
90
FLUORESCENT
34
CENTRALLY SUPPORTED-SWIVELLING-FOAM DIAPHRAGM-STEEL FACE PLATE
PUBLIC ADDRESS
NOT FITTED

ALTERNATIVES

TRACTION DATA FOR MULTIPLE UNITS

EMU- WATERLOO-BOURNEMOUTH-WEYMOUTH. INTRODUCED 1988
VOLTAGE 750 VOLTS.D.C.THIRD RAIL

BASIC TYPE

EH 288 OA

VARIANTS

NONE

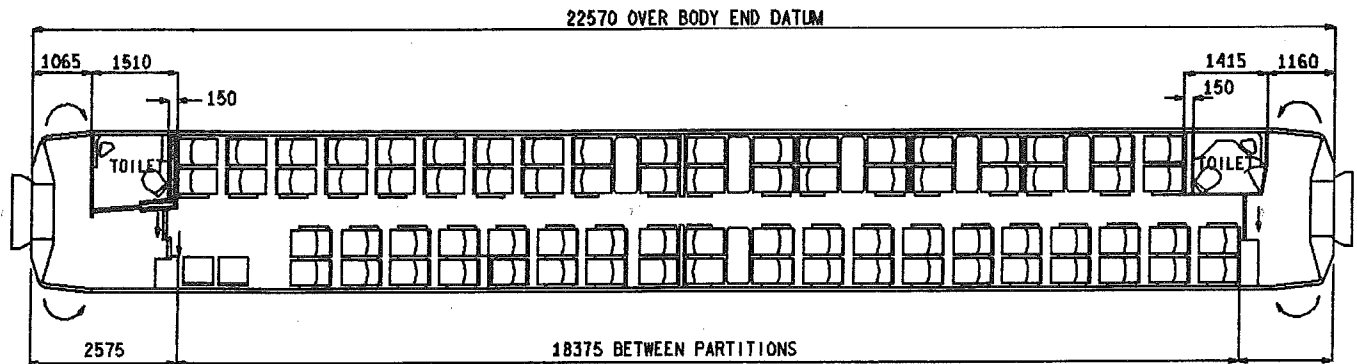
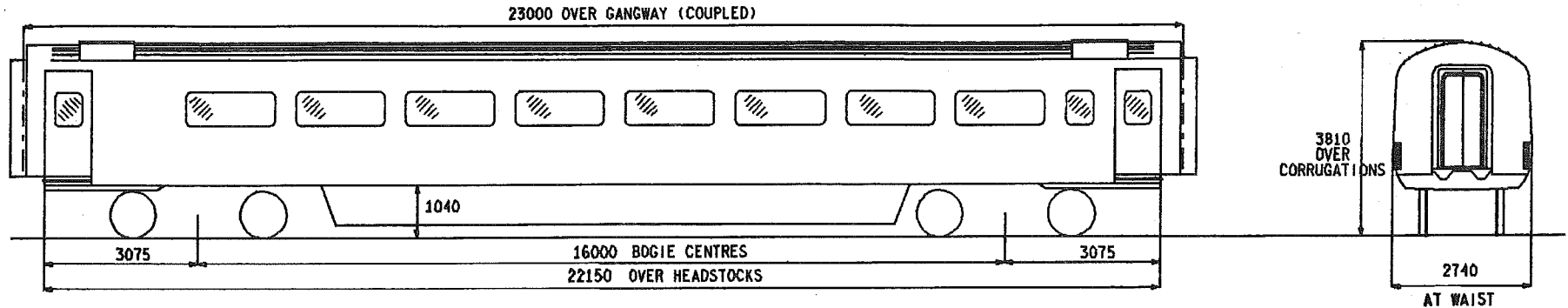

- | | |
|---------------------|-----------------------|
| SEATS | 78 |
| TOILETS | 2 |
| COMPARTMENTS | - |
| GUARDS COMPARTMENTS | - |
| VENTILATION | FULL AIR CONDITIONING |
| CATERING EQUIPMENT | - |

ISSUE DATE
1 JUL 88

EH 289

BRAKES
BOGIE/SUSPENSION
BODY CONSTRUCTION
COUPLINGS
TRAIN HEATING

MAX. SPEED M.P.H.
MIN. RAD. CURVE METRES
LIGHTING
TARE WEIGHT TONNES
GANGWAYS

BUFFERS

TRAIN COMMUNICATION

BASIC TYPE

ELECTRO-PNEUMATIC
T3-7 (BREL)
STEEL
BAR
ELECTRIC(BR) FULL AIR CONDITIONING

100
90
FLUORESCENT
34
CENTRALLY SUPPORTED-SWIVELLING-FLE DIAPHRAGM-STEEL FACE PLATE

NOT FITTED

PUBLIC ADDRESS

ALTERNATIVES

TRACTION DATA FOR MULTIPLE UNITS

EMU- WATERLOO-BOURNEMOUTH-WEYMOUTH. INTRODUCED 1988
VOLTAGE 750 VOLTS D.C. THIRD RAIL

BASIC TYPE

EH 289

VARIANTS

NONE

100
90
FLUORESCENT
34
CENTRALLY SUPPORTED-SWIVELLING-FLE DIAPHRAGM-STEEL FACE PLATE

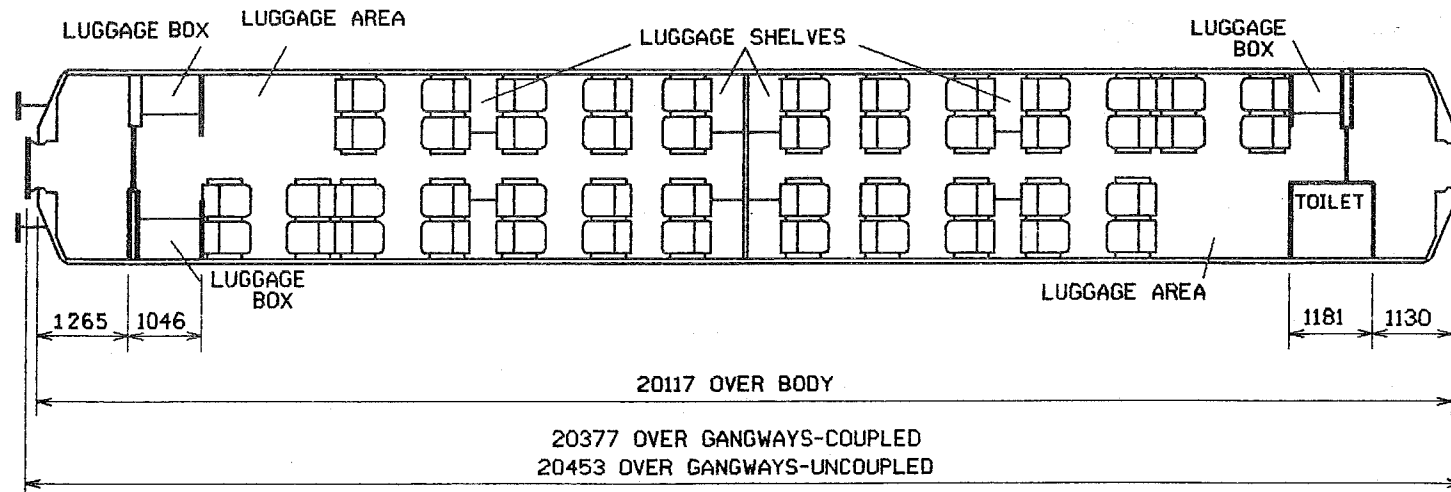
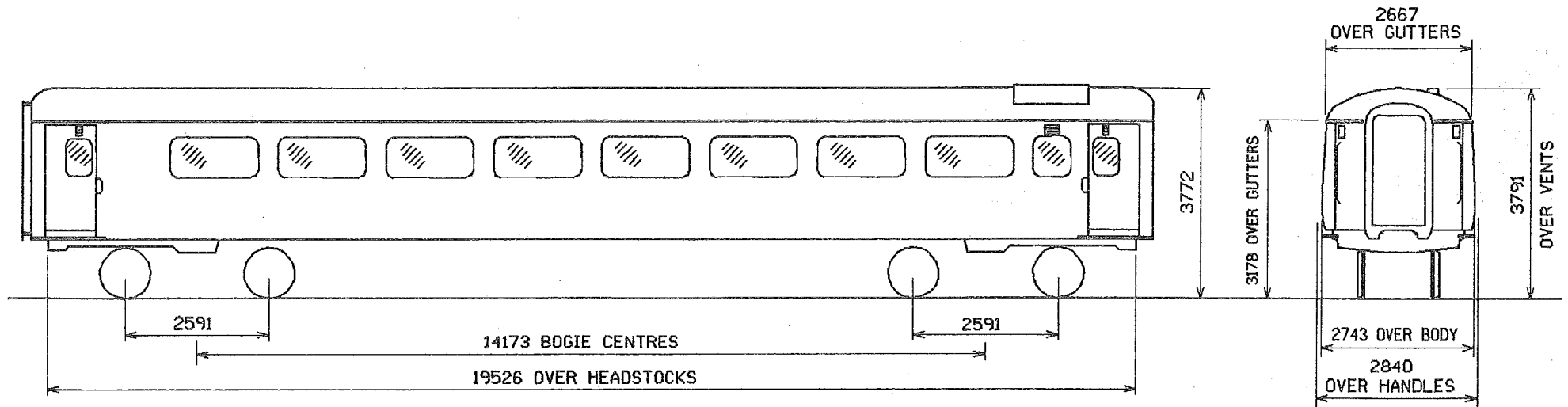

SEATS	48
TOILETS	1
COMPARTMENTS	-
GUARDS COMPARTMENTS	-
VENTILATION	FULL AIR CONDITIONING
CATERING EQUIPMENT	-

ISSUE DATE
 1 APR'88

EH 290

BASIC TYPE

BRAKES
BOGIE/SUSPENSION
BODY CONSTRUCTION
COUPLINGS
TRAIN HEATING
MAX SPEED M.P.H.
MIN.RAD.CURVE CHAINS
LIGHTING
TARE WEIGHT TONNES
GANGWAYS
TRAIN COMMUNICATION
BUFFERS

ELECTRO PNEUMATIC
B4
STEEL
BAR
ELECTRIC(BR)FULL AIR CONDITIONING
90
3.5
FLUORESCENT & TUNGSTEN
35(ESTIMATED)
PULLMAN
PUBLIC ADDRESS
NOT FITTED

ALTERNATIVES

TRACTION DATA FOR MULTIPLE UNITS

EMU- VICTORIA-GATWICK CONVERTED MK IIF INTRODUCED 1984.
VOLTAGE 750 VOLTS D.C.THIRD RAIL

BASIC TYPE

EH 290 DA

VARIANTS

NONE

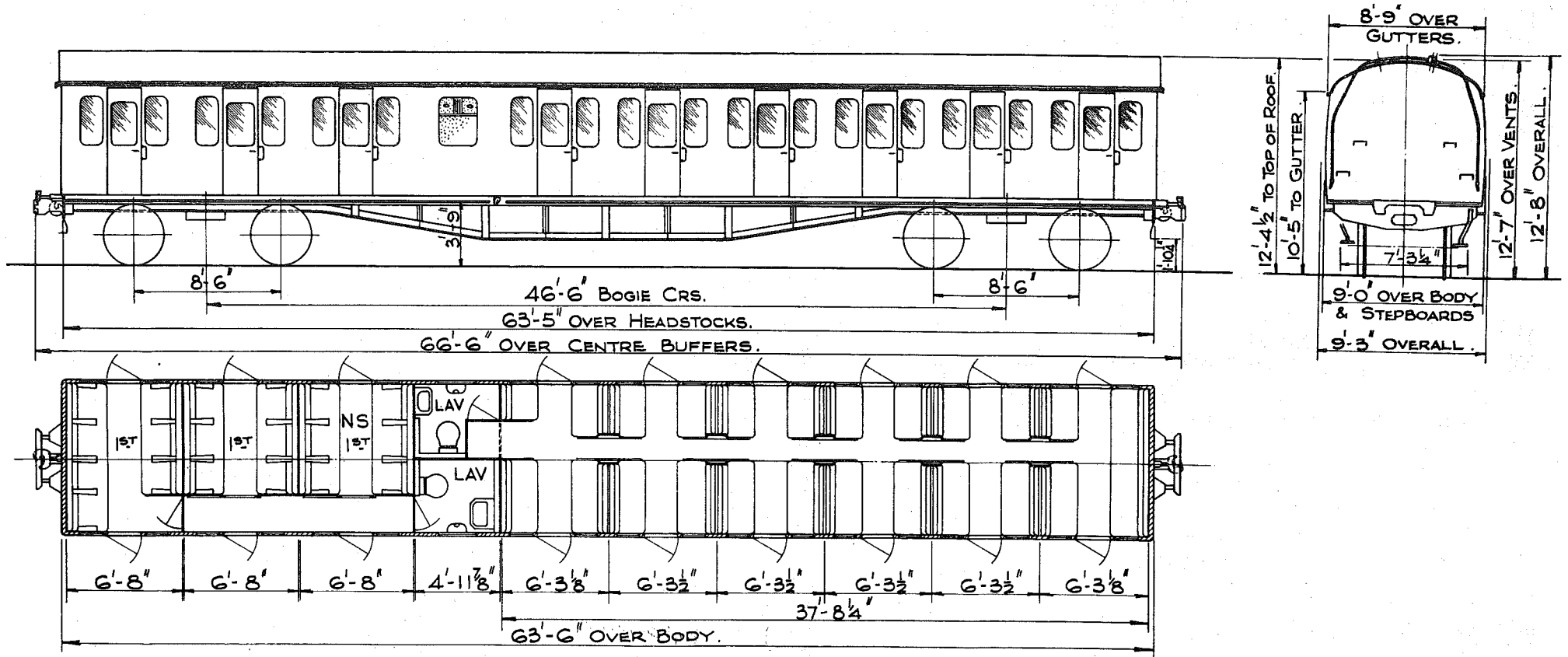

SEATS
TOILETS
COMPARTMENTS
GUARDS COMPARTMENTS
VENTILATION
CATERING EQUIPMENT

19 FIRST CLASS 60 SECOND CLASS
2
3 FIRST CLASS PLUS 1 SECOND CLASS SALOON
-
-

ORIGINAL DIAGRAMS FOR REFERENCE:-
BR 455

ISSUE DATE
4 MAR 87

EH 302

BASIC TYPE

ALTERNATIVES

BRAKES
BOGIE/SUSPENSION
BODY CONSTRUCTION
COUPLINGS
TRAIN HEATING
MAX.SPEED M.P.H.
MIN.RAD.CURVE CHAINS
LIGHTING
TARE WEIGHT TONNES
GANGWAYS
TRAIN COMMUNICATION
BUFFERS

ELECTRO PNEUMATIC
GRESLEY ET2
STEEL
AUTOMATIC SOLID SHANK (ALLIANCE No.2)
ELECTRIC (BR)
75
3.5
TUNGSTEN
30.5
NOT FITTED
NOT FITTED
NOT FITTED

B4

TRACTION DATA FOR MULTIPLE UNITS

EMU- FENCHURCH ST.- SHOEBURYNESS INTRODUCED 1958

VOLTAGE 25 & 6.25 KV A.C.OVERHEAD

BASIC TYPE

EH 302 0A

VARIANTS

OB 54 BOGIES.

TRAILER COMPOSITE

CLASS 304/1

TC

EH 303

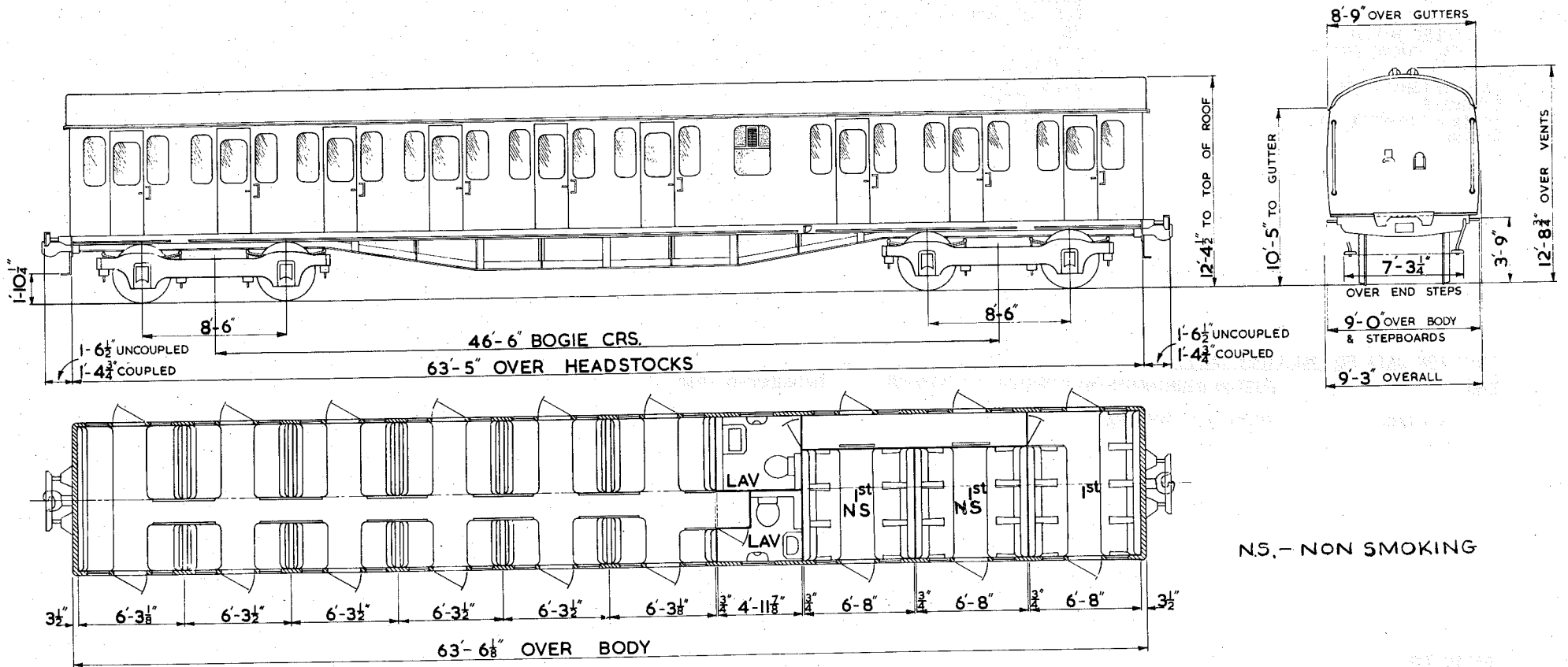

NS.- NON SMOKING

SEATS
TOILETS
COMPARTMENTS
GUARDS COMPARTMENTS
VENTILATION
CATERING EQUIPMENT

19 FIRST CLASS 60 SECOND CLASS
2
3 FIRST CLASS PLUS 1 SECOND CLASS SALOON
-
-
-

ORIGINAL DIAGRAMS FOR REFERENCE.-
BR 456

ISSUE 1
DATE SEP' 80

EH 303

BASIC TYPE

ALTERNATIVES

BRAKES
BOGIE/SUSPENSION
BODY CONSTRUCTION
COUPLINGS
TRAIN HEATING
MAX. SPEED M.P.H.
MIN. RAD. CURVE CHAINS
LIGHTING
TARE WEIGHT TONNES
GANGWAYS
TRAIN COMMUNICATION
BUFFERS

ELECTRO PNEUMATIC
GRESLEY ET8
STEEL
AUTOMATIC SOLID SHANK (ALLIANCE NO.2)
ELECTRIC (BR)
75
3.5
ELECTRIC
31.5
NOT FITTED
NOT FITTED
NOT FITTED

TRACTION DATA FOR MULTIPLE UNITS

EMU- EUSTON-BIRMINGHAM-MANCHESTER & LIVERPOOL. INTRODUCED 1960.
VOLTAGE - 25 KV A.C.OVERHEAD

BASIC TYPE

EH 303 0A

VARIANTS

NONE

TRAILER COMPOSITE

CLASS 304/2
304/3

TC

EH 304

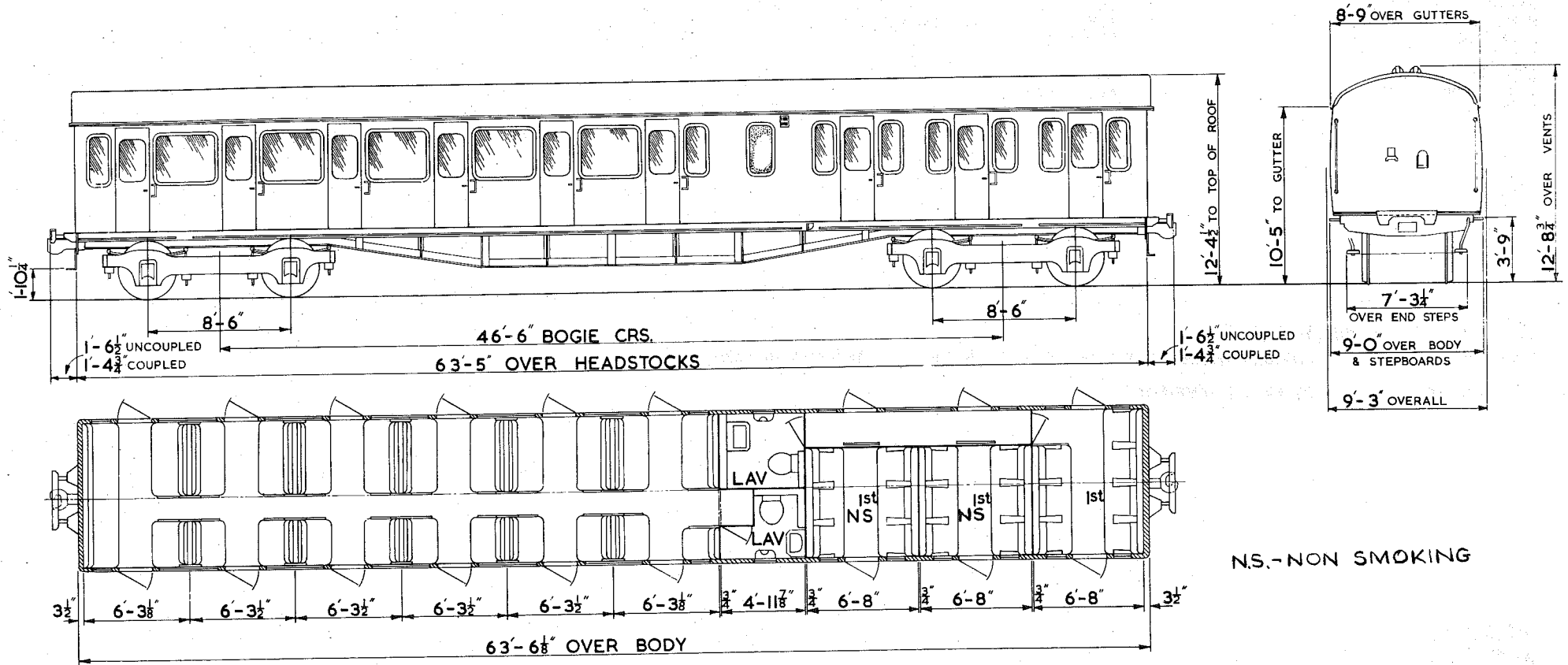

NS.-NON SMOKING

- SEATS
- TOILETS
- COMPARTMENTS
- GUARDS COMPARTMENTS
- VENTILATION
- CATERING EQUIPMENT

- 19 FIRST CLASS 60 SECOND CLASS
- 2
- 3 FIRST CLASS PLUS 1 SECOND CLASS SALOON
-
-
-

ORIGINAL DIAGRAMS FOR REFERENCE.-
BR 457

ISSUE DATE
1 SEP' 80

EH 304

BASIC TYPE

BRAKES
BOGIE/SUSPENSION
BODY CONSTRUCTION
COUPLINGS
TRAIN HEATING
MAX. SPEED M.P.H.
MIN. RAD. CURVE CHAINS
LIGHTING
TARE WEIGHT TONNES
GANGWAYS
TRAIN COMMUNICATION
BUFFERS

ELECTRO PNEUMATIC
GRESLEY ET8
STEEL
AUTOMATIC SOLID SHANK (ALLIANCE NO.2)
ELECTRIC (BR)
75
3.5
ELECTRIC
32.5
NOT FITTED
NOT FITTED
NOT FITTED

ALTERNATIVES

TRACTION DATA FOR MULTIPLE UNITS

EMU- EUSTON-BIRMINGHAM-MANCHESTER & LIVERPOOL. - INTRODUCED 1960.
VOLTAGE 25 KV A.C.OVERHEAD

BASIC TYPE

EH 304 0A

VARIANTS

NONE

TRAILER COMPOSITE

CLASS 317/1

TC

EH 307

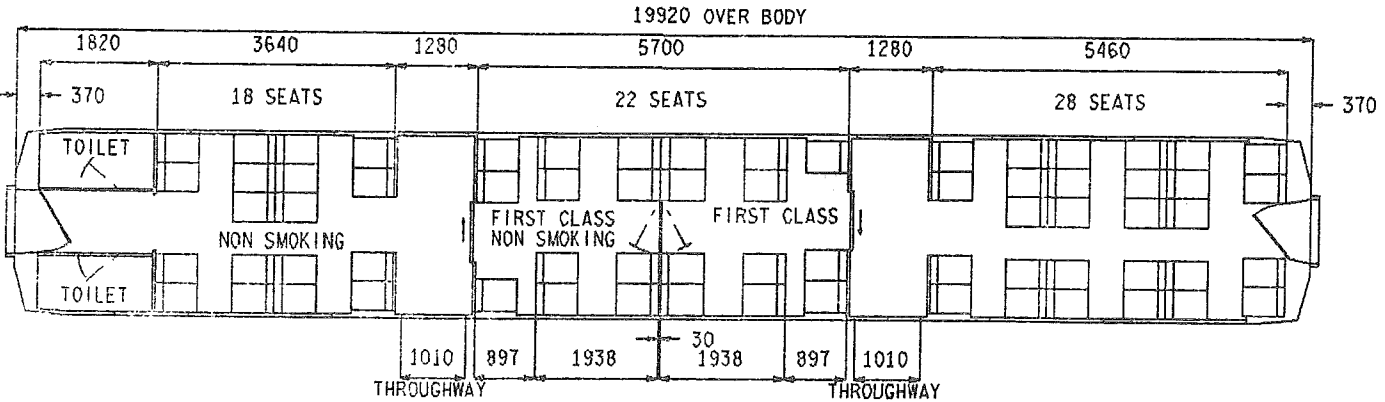
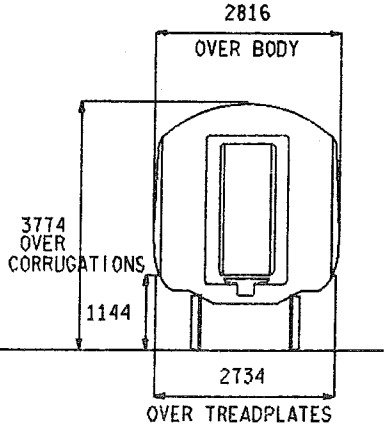
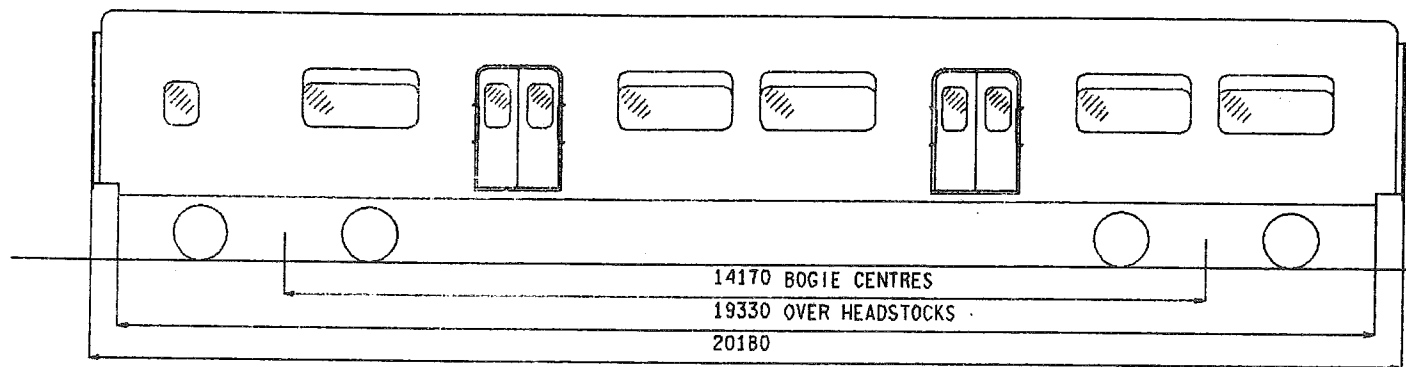

VARIANT OB SMOKING/NO SMOKING AREAS REVERSED

- SEATS 22 FIRST CLASS 46 SECOND CLASS
- TOILETS 2
- COMPARTMENTS -
- GUARDS COMPARTMENTS -
- VENTILATION PRESSURE
- CATERING EQUIPMENT -

ORIGINAL DIAGRAMS FOR REFERENCE:- BR 466

ISSUE 7 DATE NOV 88

EH 307

BRAKES
BOGIE/SUSPENSION
BODY CONSTRUCTION
COUPLINGS
TRAIN HEATING
MAX.SPEED M.P.H.
MIN.RAD.CURVE CHAINS
LIGHTING
TARE WEIGHT TONNES
GANGWAYS
TRAIN COMMUNICATION
BUFFERS

BASIC TYPE

ELECTRO PNEUMATIC
BT13
STEEL
BAR
ELECTRIC(BR)WITH PRESSURE VENTILATION & HEATING
90
3.5
FLUORESCENT & TUNGSTEN
29
FLEXIBLE DIAPHRAGM/RIGID(GRP)
PUBLIC ADDRESS
NOT FITTED

ALTERNATIVES

TRACTION DATA FOR MULTIPLE UNITS

EMU- ST.PANCRAS & MOORGATE-BEDFORD, TRANSFERED TO E.R. OR W.C.M.L.
VOLTAGE 25 KV A.C.OVERHEAD

BASIC TYPE

EH 307 OA

VARIANTS

OB SMOKING/NO SMOKING AREAS REVERSED IN CENTRE BAYS.

TRAILER OPEN COMPOSITE

CLASS 317/2

TOC

EH 308

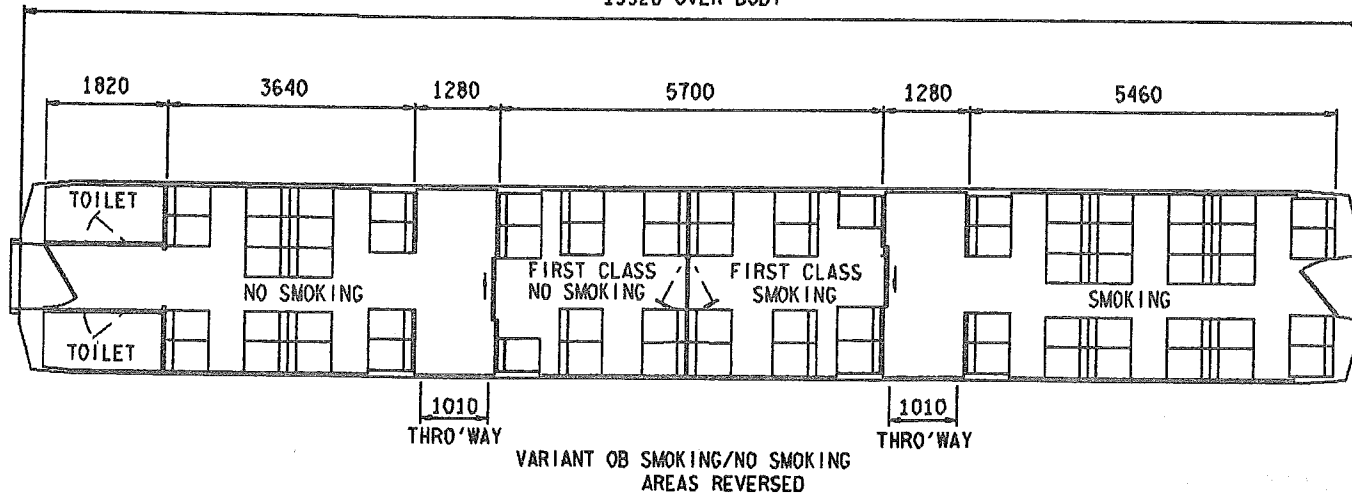
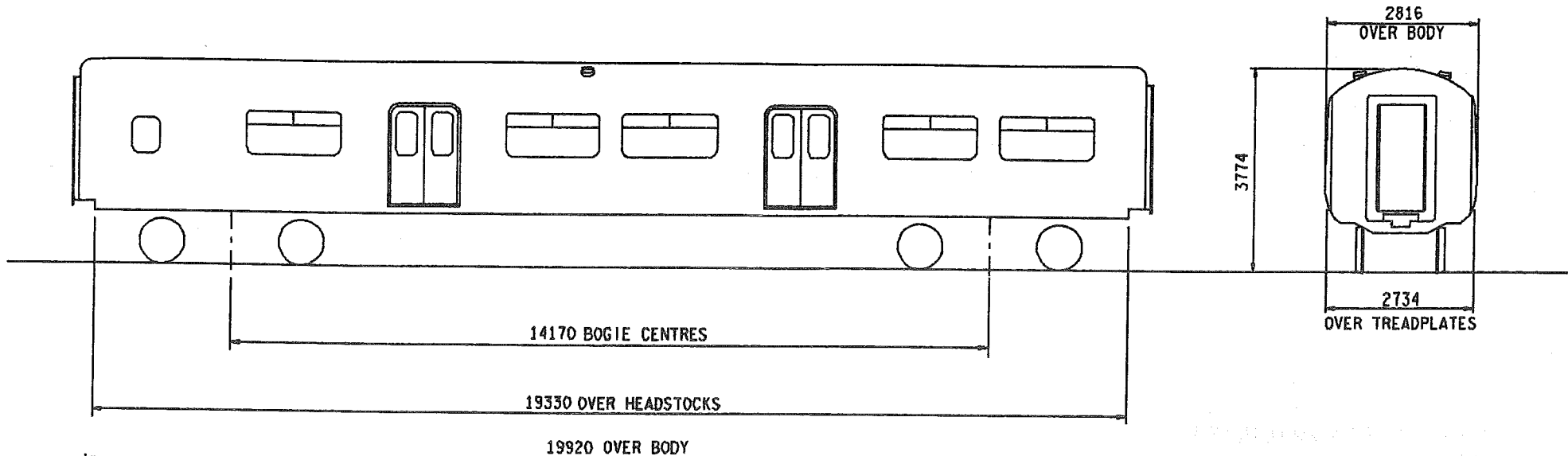

- | | |
|---------------------|---------------------------------|
| SEATS | 22 FIRST CLASS. 46 SECOND CLASS |
| TOILETS | 2 |
| COMPARTMENTS | - |
| GUARDS COMPARTMENTS | - |
| VENTILATION | - |
| CATERING EQUIPMENT | - |

ISSUE 3 DATE NOV 88

EH 308

BRAKES
BOGIE/SUSPENSION
BODY CONSTRUCTION
COUPLINGS
TRAIN HEATING
MAX. SPEED M.P.H.
MIN. RAD. CURVE CHAINS
LIGHTING
TARE WEIGHT TONNES
GANGWAYS

A.W.S.
TRAIN COMMUNICATION
BUFFERS

BASIC TYPE

ELECTRO-PNEUMATIC
BT13a & BT13b (ONE OF EACH)
STEEL
AUTOMATIC TIGHTLOCK OUTER END-BAR INNER END
ELECTRIC (BR)
90
3.5
FLUORESCENT & TUNGSTEN
28.3
CENTRALLY SUPPORTED-SWIVELLING-FLEXIBLE DIAPHRAGM-STEEL FACE PLATE
OUTER END-FLEXIBLE DIAPHRAGM/RIGID (GRP) INNER END
FITTED
DRIVER/SIGNAL BOX-DRIVER/GUARD-PUBLIC ADDRESS WITH TRANSMITTER
NOT FITTED

ALTERNATIVES

TRACTION DATA FOR MULTIPLE UNITS

EMU- GREAT NORTHERN OUTER SUBURBAN
VOLTAGE 25 KV A.C. OVERHEAD

BASIC TYPE

EH 308 0A

VARIANTS

OB SMOKING/NO SMOKING AREAS REVERSED IN CENTRE BAYS.

TRAILER COMPOSITE

CLASS 309/1

TC

EH 309

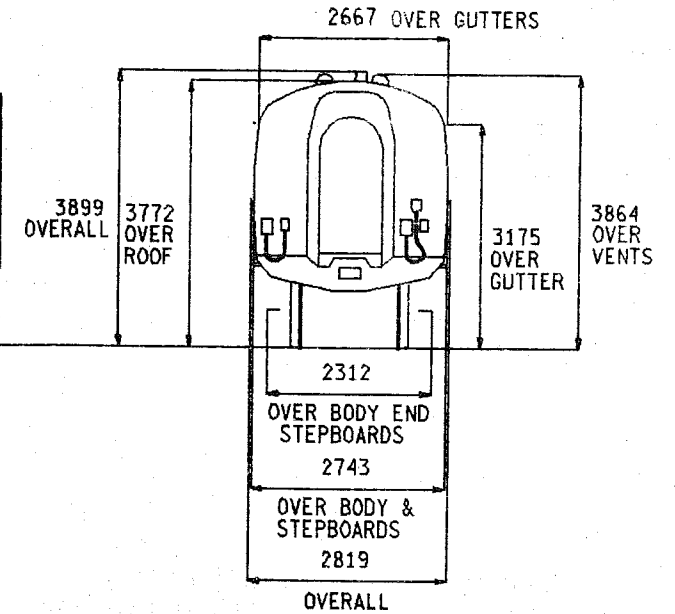
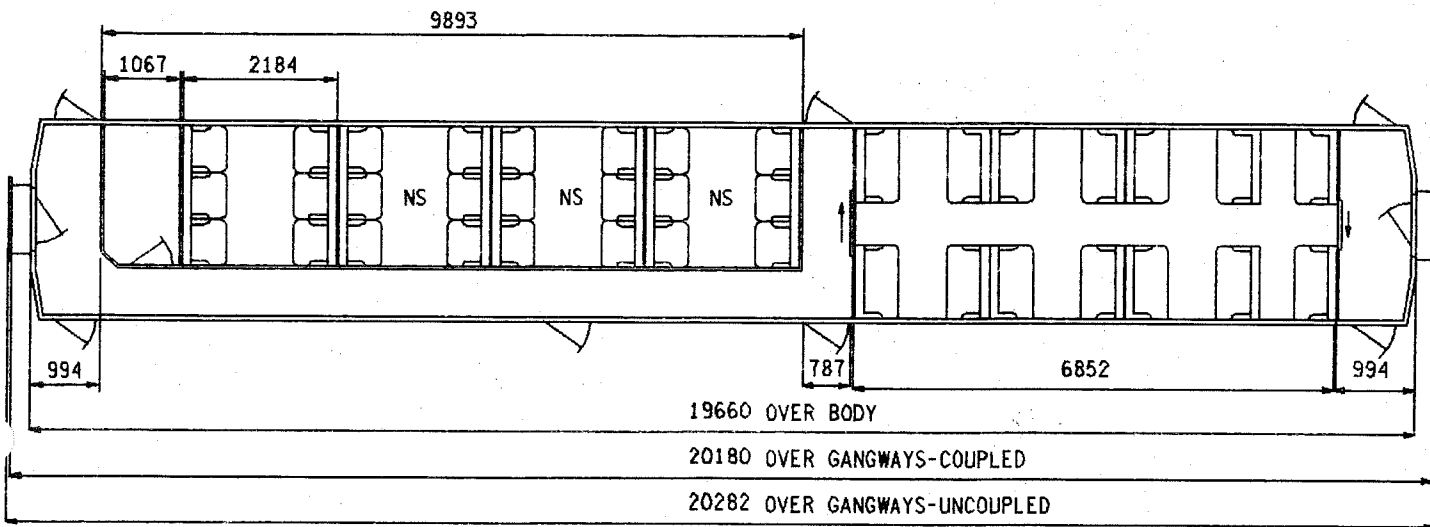
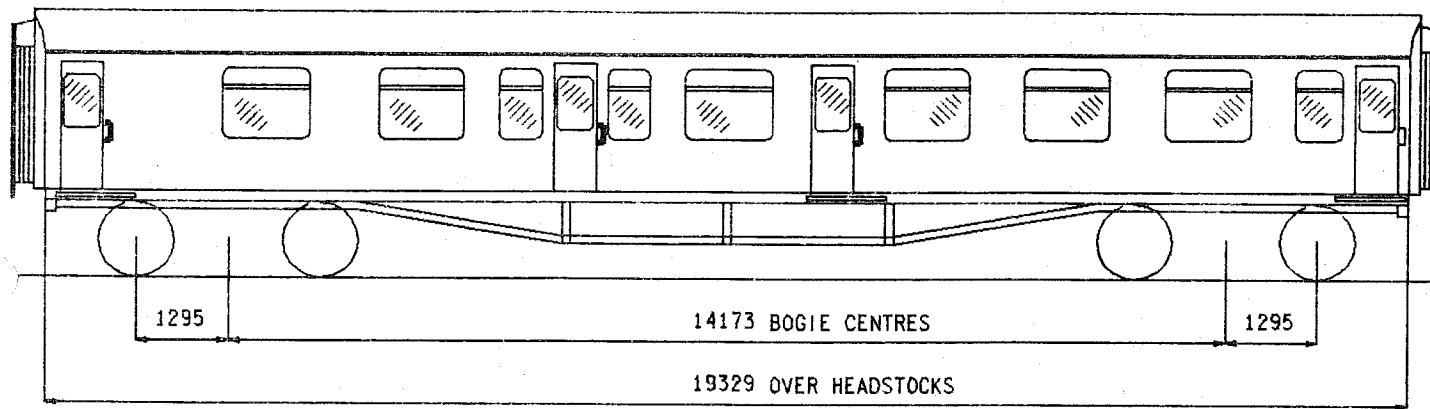

NS - NON SMOKING

SEATS	28
TOILETS	1
COMPARTMENTS	4
GUARDS COMPARTMENTS	-
VENTILATION	-
CATERING EQUIPMENT	-

ISSUE 2 DATE MAR 87

EH 309

BRAKES
BOGIE/SUSPENSION
BODY CONSTRUCTION
COUPLINGS
TRAIN HEATING
MAX. SPEED M.P.H.
MIN. RAD. CURVE CHAINS
LIGHTING
TARE WEIGHT TONNES
GANGWAYS
TRAIN COMMUNICATION
BUFFERS

BASIC TYPE

ELECTRO PNEUMATIC
COMMONWEALTH
STEEL
AUTOMATIC SOLID SHANK (ALLIANCE NO. 2)
ELECTRIC (BR)
100
3.5
FLUORESCENT & TUNGSTEN
36
PULLMAN
PUBLIC ADDRESS
NOT FITTED

ALTERNATIVES

TRACTION DATA FOR MULTIPLE UNITS

EMU- LIVERPOOL ST.-CLACTON & WALTON INTRODUCED 1962, REFURBISHED 1985.
VOLTAGE 25 & 6.25 KV A.C. OVERHEAD.

BASIC TYPE

EH 309 0A

VARIANTS

NONE

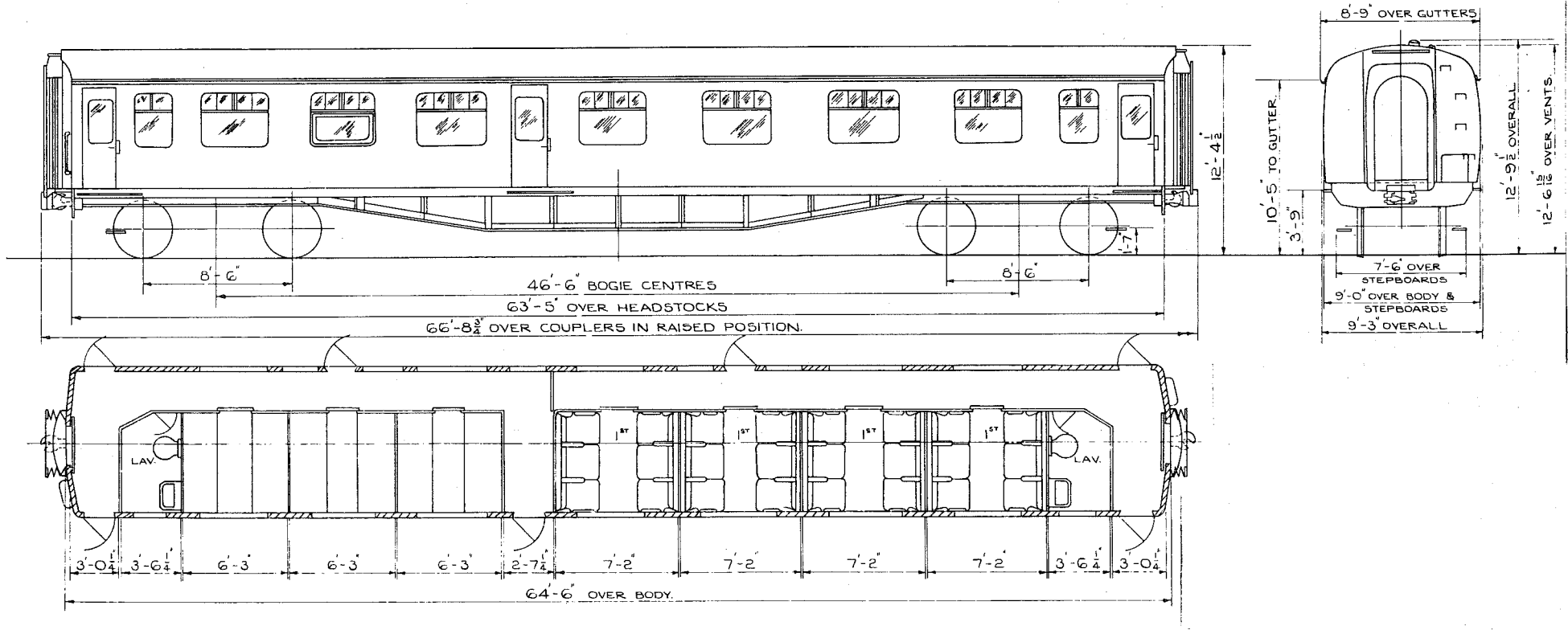

SEATS	24 FIRST CLASS 24 SECOND CLASS
TOILETS	2
COMPARTMENTS	4 FIRST CLASS 3 SECOND CLASS
GUARDS COMPARTMENTS	-
VENTILATION	-
CATERING EQUIPMENT	-

ORIGINAL DIAGRAMS FOR REFERENCE:-
BR 450

ISSUE 3 DATE JAN 84

EH 360

BRAKES
BOGIE/SUSPENSION
BODY CONSTRUCTION
COUPLINGS
TRAIN HEATING
MAX. SPEED M.P.H.
MIN. RAD. CURVE CHAINS
LIGHTING
TARE WEIGHT TONNES
GANGWAYS
TRAIN COMMUNICATION
BUFFERS
S.R. DESIGN REFERENCE CODE

BASIC TYPE

ELECTRO PNEUMATIC
S.R. MK 4 UNPOWERED
STEEL
AUTOMATIC SOLID SHANK (ALLIANCE NO. 2)
ELECTRIC (BR)
90
3.5
TUNGSTEN
31.5
EXPRESS ELECTRIC
PUBLIC ADDRESS
NOT FITTED
BF

ALTERNATIVES

COMMONWEALTH

TRACTION DATA FOR MULTIPLE UNITS

EMU- INTRODUCED 1956.
VOLTAGE 750/850 VOLTS D.C. THIRD RAIL

BASIC TYPE

EH 360 0A

VARIANTS

DB COMMONWEALTH BOGIES.

TRAILER COMPOSITE

CLASS 410/2
411/2

TC

EH 361

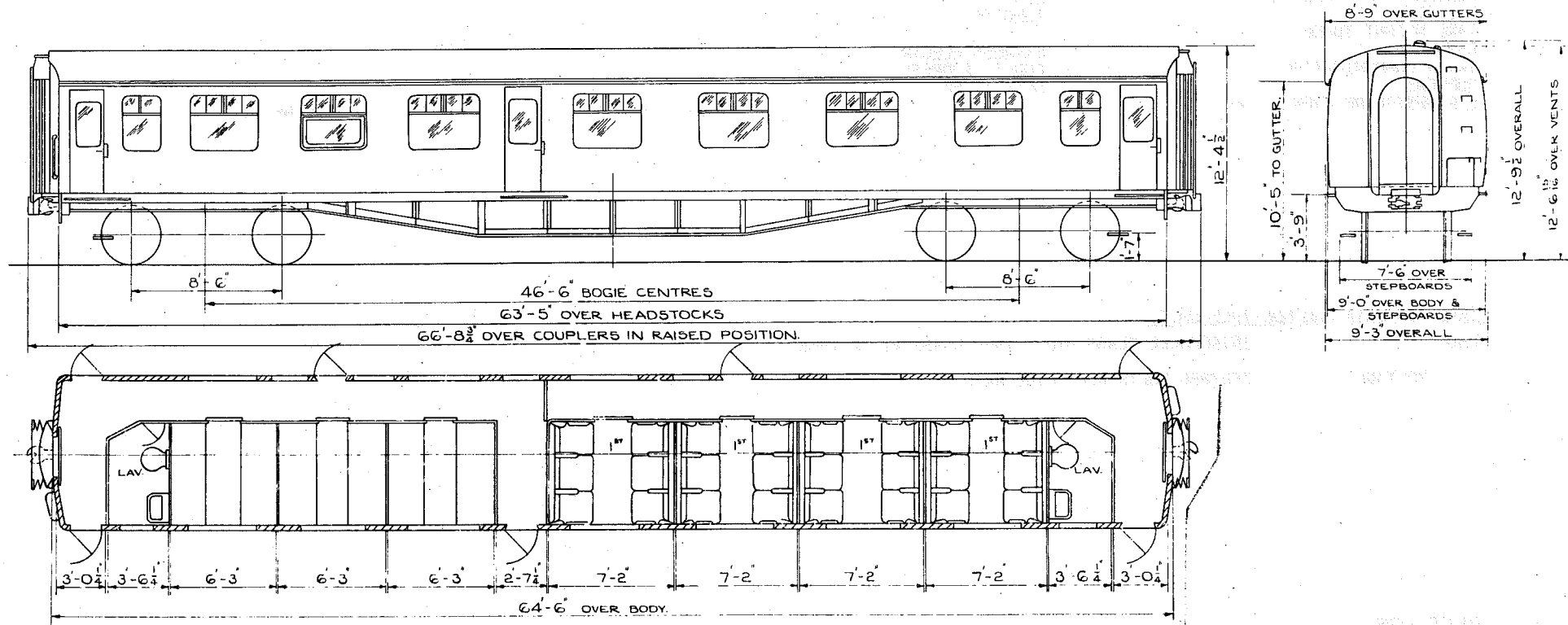

- SEATS
- TOILETS
- COMPARTMENTS
- GUARDS COMPARTMENTS
- VENTILATION
- CATERING EQUIPMENT

- 24 FIRST CLASS 24 SECOND CLASS
- 2
- 4 FIRST CLASS 3 SECOND CLASS
-
-
-

ORIGINAL DIAGRAMS FOR REFERENCE.-
BR 450

ISSUE 2 DATE MAY '81

EH 361

BRAKES
BOGIE/SUSPENSION
BODY CONSTRUCTION
COUPLINGS
TRAIN HEATING
MAX. SPEED M.P.H.
MIN. RAD. CURVE CHAINS
LIGHTING
TARE WEIGHT TONNES
GANGWAYS
TRAIN COMMUNICATION
BUFFERS
S.R. DESIGN REFERENCE CODE

BASIC TYPE

ELECTRO PNEUMATIC
S.R. MK 4 UNPOWERED
STEEL
AUTOMATIC SOLID SHANK (ALLIANCE NO.2)
ELECTRIC (BR)
90
3.5
TUNGSTEN
31.5
EXPRESS ELECTRIC
PUBLIC ADDRESS
NOT FITTED
BJ

ALTERNATIVES

COMMONWEALTH

BM, BM 1A

TRACTION DATA FOR MULTIPLE UNITS

EMU- INTRODUCED-CLASS 410/2 1959-CLASS 411/2 1958.
VOLTAGE 750/850 VOLTS D.C. THIRD RAIL

BASIC TYPE

EH 361 0A

VARIANTS

1B COMMONWEALTH BOGIES, S.R. DESIGN REFERENCE CODE BM.
2C COMMONWEALTH BOGIES, S.R. DESIGN REFERENCE CODE BM 1A.

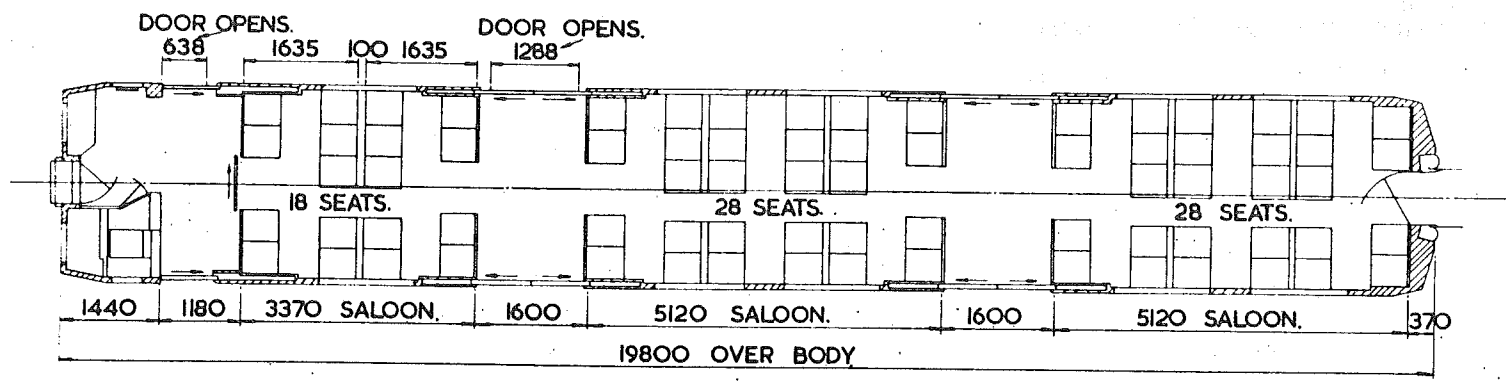
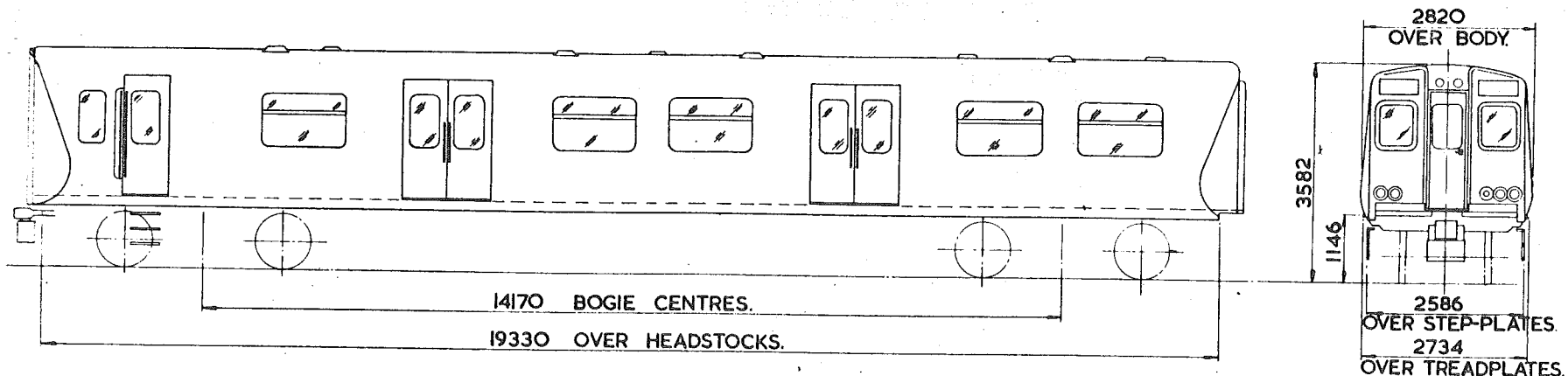

- SEATS 74
- TOILETS -
- COMPARTMENTS -
- GUARDS COMPARTMENTS -
- VENTILATION -
- CATERING EQUIPMENT -

ORIGINAL DIAGRAMS FOR REFERENCE.-
BR 486

ISSUE 2 DATE AUG '82

EI 201

BASIC TYPE

BRAKES
BOGIE/SUSPENSION
BODY CONSTRUCTION
COUPLINGS
TRAIN HEATING
MAX. SPEED M.P.H.
MIN. RAD. CURVE CHAINS
LIGHTING
TARE WEIGHT TONNES
GANGWAYS
A.V.S.
TRAIN COMMUNICATION
BUFFERS

ELECTRO PNEUMATIC
BX1/P_a & BX1/P_b (ONE OF EACH)
STEEL UNDERFRAME & BODY FRAMING-ALUMINIUM BODY & ROOF
AUTOMATIC TIGHTLOCK OUTER END-BAR INNER END
WASTE HEAT RECOVERY-DUCTED WARM AIR
75
3.5
FLUORESCENT & TUNGSTEN
37.5
FLEXIBLE DIAPHRAGM/RIGID (GRP) INNER END
FITTED
DRIVER/SIGNAL BOX, DRIVER/GUARD, PUBLIC ADDRESS
NOT FITTED

ALTERNATIVES

TRACTION DATA FOR MULTIPLE UNITS

EMU- GREAT NORTHERN INNER SUBURBAN. INTRODUCED 1976.
VOLTAGE 25 KV A.C. OVERHEAD & 750 VOLTS D.C. THIRD RAIL
TRACTION MOTORS 4 X 110 HP GEC G310AZ

BASIC TYPE

EI 201 0A

VARIANTS

NONE

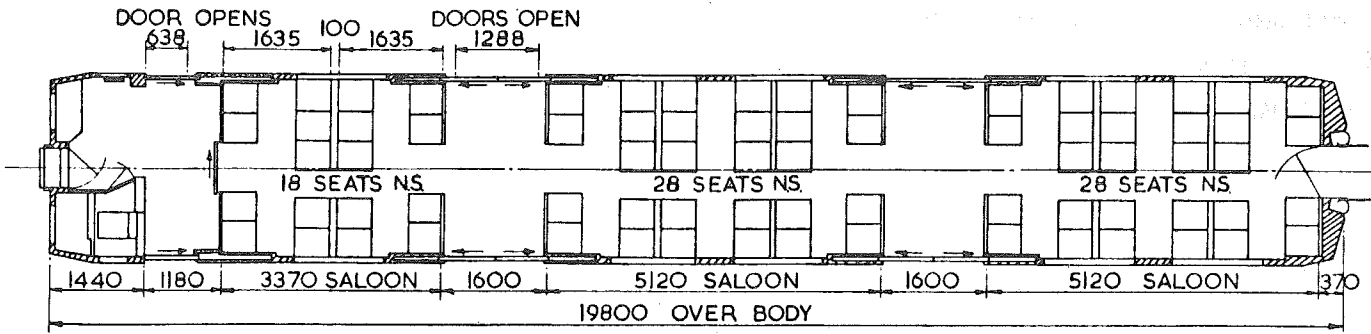
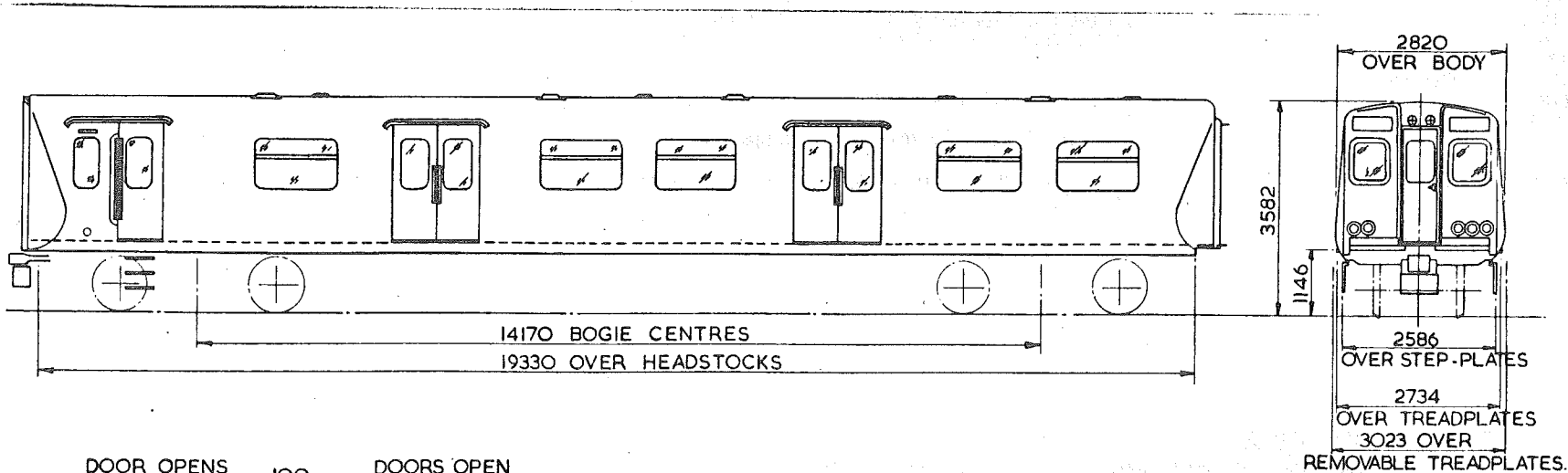

NS - NON SMOKING.

- SFATS 74
- TOILETS -
- COMPARTMENTS -
- GUARDS COMPARTMENTS CAB WHEN TRAILING
- VENTILATION -
- CATERING EQUIPMENT -

ORIGINAL DIAGRAMS FOR REFERENCE.-
BR 863

ISSUE 3 DATE AUG '82

EI 202

BASIC TYPE

ALTERNATIVES

BRAKES
BOGIE/SUSPENSION
BODY CONSTRUCTION
COUPLINGS
TRAIN HEATING
MAX. SPEED M.P.H.
MIN. RAD. CURVE CHAINS
LIGHTING
TARE WEIGHT TONNES
GANGWAYS
A. V. S.
TRAIN COMMUNICATION
BUFFERS

ELECTRO PNEUMATIC
BX1/Pc & BX1/Pg (ONE OF EACH)
STEEL UNDERFRAME & BODY FRAMING-ALUMINIUM BODY & ROOF
AUTOMATIC TIGHTLOCK OUTER END-BAR INNER END
ELECTRIC-DUCTED WARM AIR
75
3.5
FLUORESCENT & TUNGSTEN
37
FLEXIBLE DIAPHRAGM/RIGID (GRP) INNER END
FITTED
DRIVER/GUARD-PUBLIC ADDRESS WITH TRANSMITTER
NOT FITTED

TRACTION DATA FOR MULTIPLE UNITS

EMU- GARSTON-LIVERPOOL-SOUTHPORT. INTRODUCED 1979.
VOLTAGE 600/750 VOLTS D.C. THIRD RAIL
TRACTION MOTORS 4 X 110 HP GEC G310AZ

BASIC TYPE

EI 202 0A

VARIANTS

NONE

BATTERY DRIVING MOTOR SECOND

CLASS 508

BDMS

EI 203

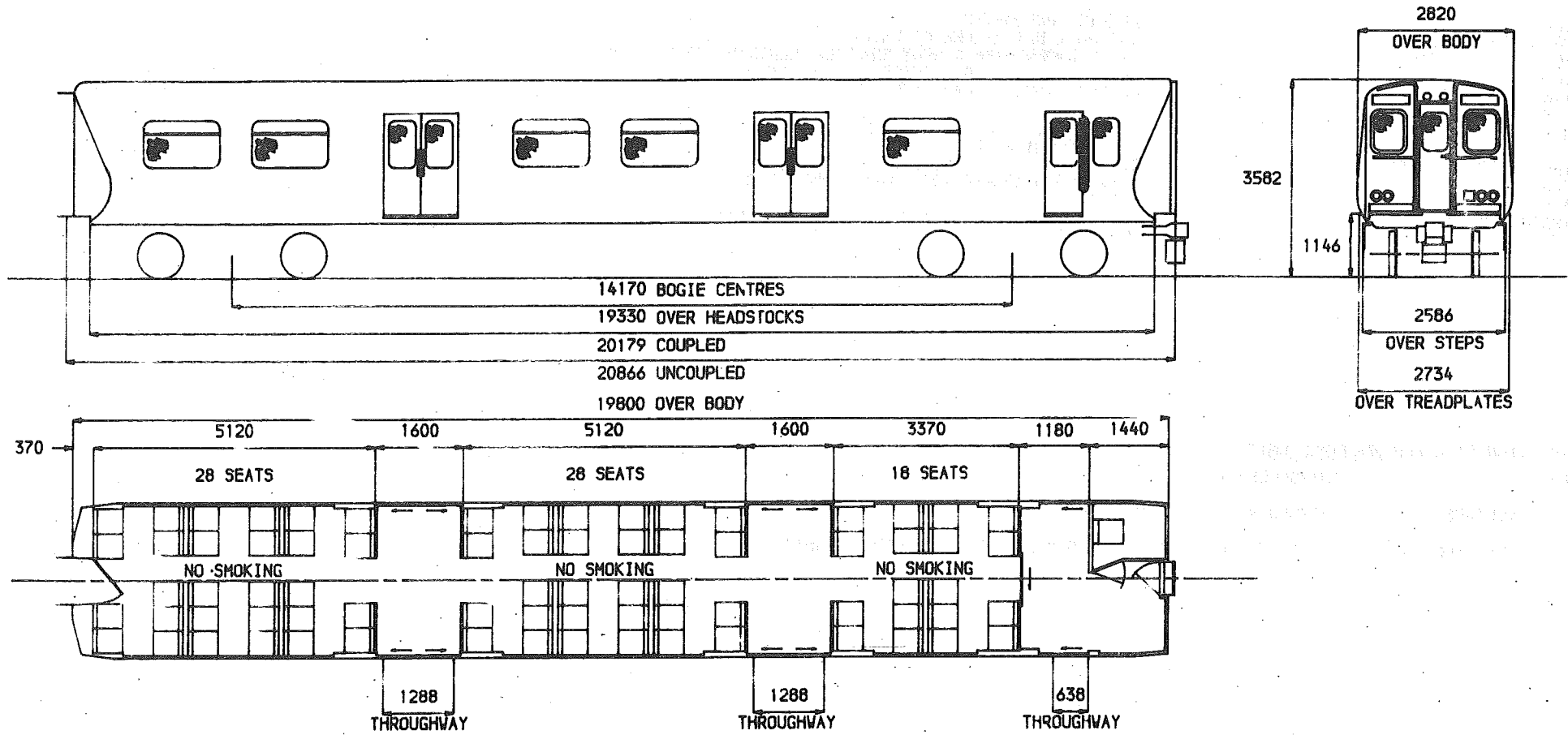

- SEATS 74
- TOILETS -
- COMPARTMENTS -
- GUARDS COMPARTMENTS CAB WHEN TRAILING
- VENTILATION -
- CATERING EQUIPMENT -

ISSUE 3 DATE AUG' 82

BASIC TYPE

ALTERNATIVES

BRAKES
BOGIE/SUSPENSION
BODY CONSTRUCTION
COUPLINGS
TRAIN HEATING
MAX. SPEED M.P.H.
MIN. RAD. CURVE CHAINS
LIGHTING
TARE WEIGHT TONNES
GANGWAYS
A.W.S.
TRAIN COMMUNICATION
BUFFERS

ELECTRO PNEUMATIC
BX1/Ph & BX1/PJ (ONE OF EACH)
STEEL UNDERFRAME & BODY FRAMING-ALUMINIUM BODY & ROOF
AUTOMATIC TIGHTLOCK OUTER END-BAR INNER END
ELECTRIC-DUCTED WARM AIR
75
3.5
FLUORESCENT & TUNGSTEN
36.5
FLEXIBLE DIAPHRAGM/RIGID (GRP) INNER END
FITTED
DRIVER/GUARD-PUBLIC ADDRESS WITH TRANSMITTER
NOT FITTED

TRACTION DATA FOR MULTIPLE UNITS

EMU- INTRODUCED 1980.
VOLTAGE 750/850 VOLTS D.C. THIRD RAIL
TRACTION MOTORS 4 X 110 HP GEC G310AZ OR BRUSH TM 61-53 -INTERCHANGEABLE.

BASIC TYPE

EI 203 0A

VARIANTS

NONE

TRAILER BRAKE FIRST

CLASS 432

TBF

EJ 160

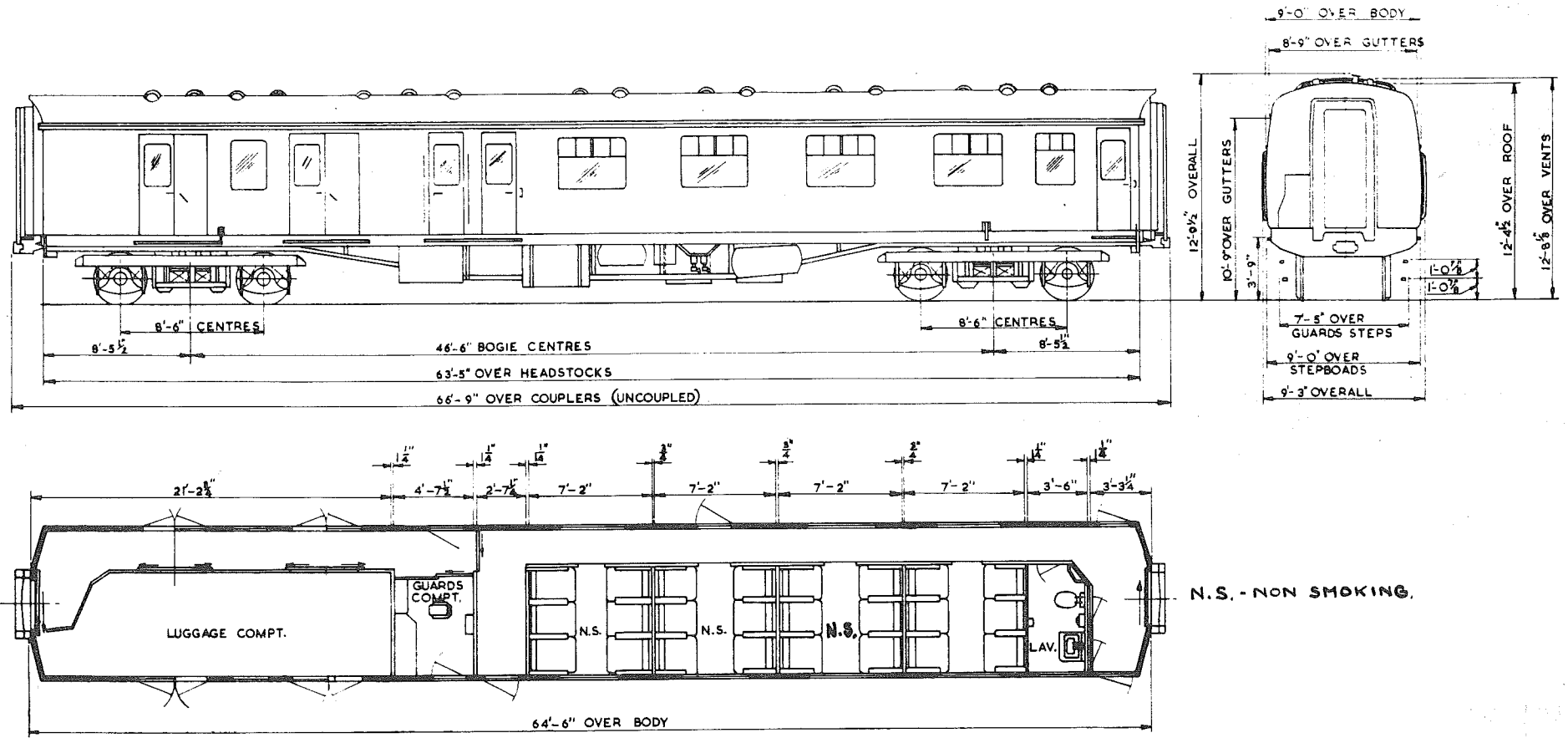

N.S. - NON SMOKING.

SEATS	24
TOILETS	1
COMPARTMENTS	4
GUARDS COMPARTMENTS	1
VENTILATION	-
CATERING EQUIPMENT	-

ORIGINAL DIAGRAMS FOR REFERENCE:-
BR 910A

ISSUE 3 DATE NOV 84

EJ 160

BASIC TYPE

BRAKES
BOGIE/SUSPENSION
BODY CONSTRUCTION
COUPLINGS
TRAIN HEATING
MAX.SPEED M.P.H.
MIN.RAD.CURVE CHAINS
LIGHTING
TARE WEIGHT TONNES
GANGWAYS
TRAIN COMMUNICATION
BUFFERS
S.R.DESIGN REFERENCE CODE

ELECTRO PNEUMATIC
B5(S.R.)
STEEL
AUTOMATIC SOLID SHANK(ALLIANCE NO 2)
ELECTRIC(BR)
90
3.5
TUNGSTEN
35.5
EXPRESS ELECTRIC
DRIVER/GUARD
NOT FITTED
BR

ALTERNATIVES

BR 1A

TRACTION DATA FOR MULTIPLE UNITS

EMU- INTRODUCED 1966,RECLASSIFIED 1984.
VOLTAGE 750/850 VOLTS D.C.THIRD RAIL

BASIC TYPE

EJ 160 OA

VARIANTS

1B S.R.DESIGN REFERENCE CODE BR 1A.

TRAILER BRAKE SECOND

CLASS 437

TBS

EJ 260

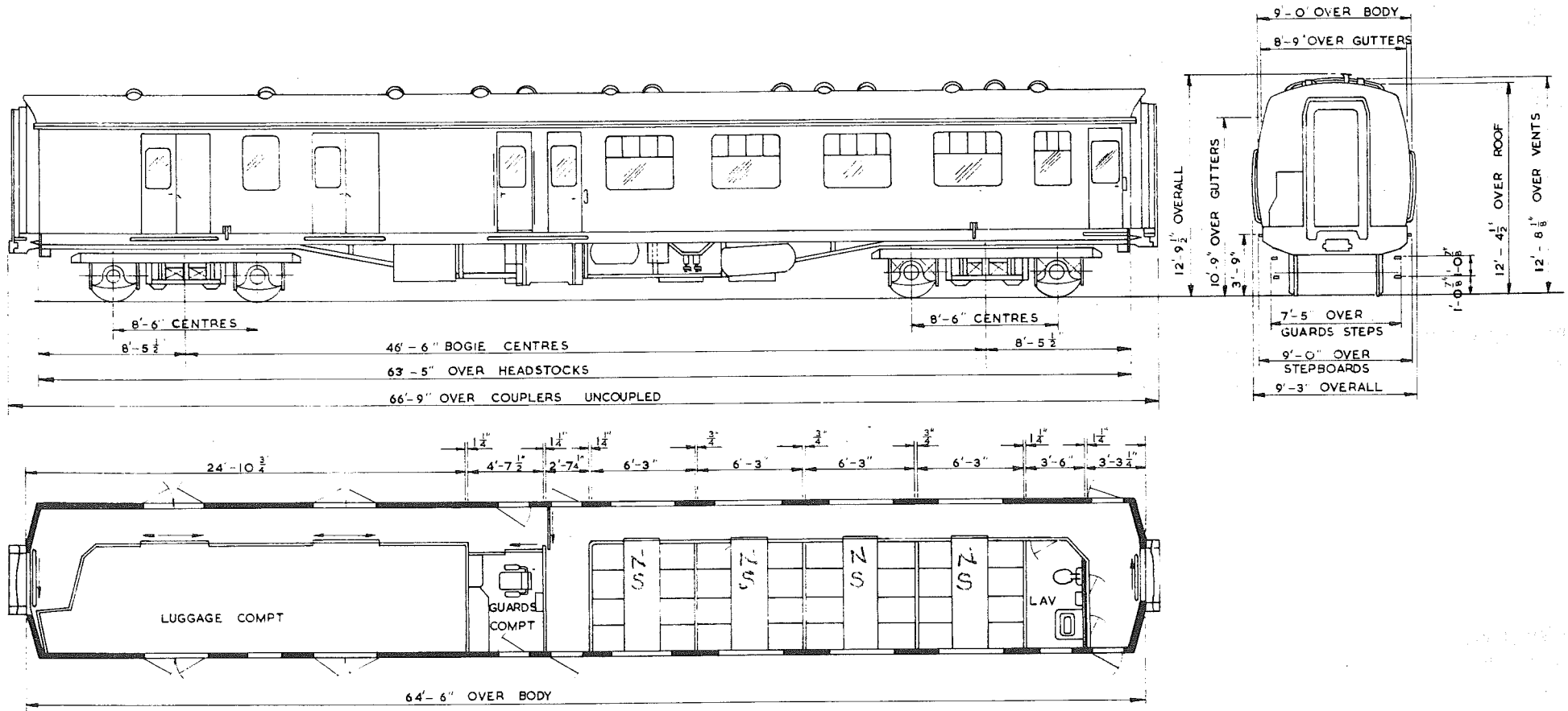

SEATS	32
TOILETS	1
COMPARTMENTS	4
GUARDS COMPARTMENTS	1
VENTILATION	-
CATERING EQUIPMENT	-

ORIGINAL DIAGRAMS FOR REFERENCE:-
BR 920A

ISSUE 4 DATE NOV 84

EJ 260

BASIC TYPE

BRAKES
BOGIE/SUSPENSION
BODY CONSTRUCTION
COUPLINGS
TRAIN HEATING
MAX.SPEED M.P.H.
MIN.RAD.CURVE CHAINS
LIGHTING
TARE WEIGHT TONNES
GANGWAYS
TRAIN COMMUNICATION
BUFFERS
S.R.DESIGN REFERENCE CODE

ELECTRO PNEUMATIC
B5(S.R.)
STEEL
AUTOMATIC SOLID SHANK(ALLIANCE NO.2)
ELECTRIC(BR)
90
3.5
TUNGSTEN
35.5
EXPRESS ELECTRIC
DRIVER/GUARD & PUBLIC ADDRESS WITH TRANSMITTER
NOT FITTED
BT

ALTERNATIVES

BT 1A

TRACTION DATA FOR MULTIPLE UNITS

EMU- INTRODUCED 1966 AS CLASS 491,RECLASSED 1984.
VOLTAGE 750/850 VOLTS D.C.THIRD RAIL

BASIC TYPE

EJ 260 GA

VARIANTS

1B S.R.DESIGN REF.CODE BT 1A.

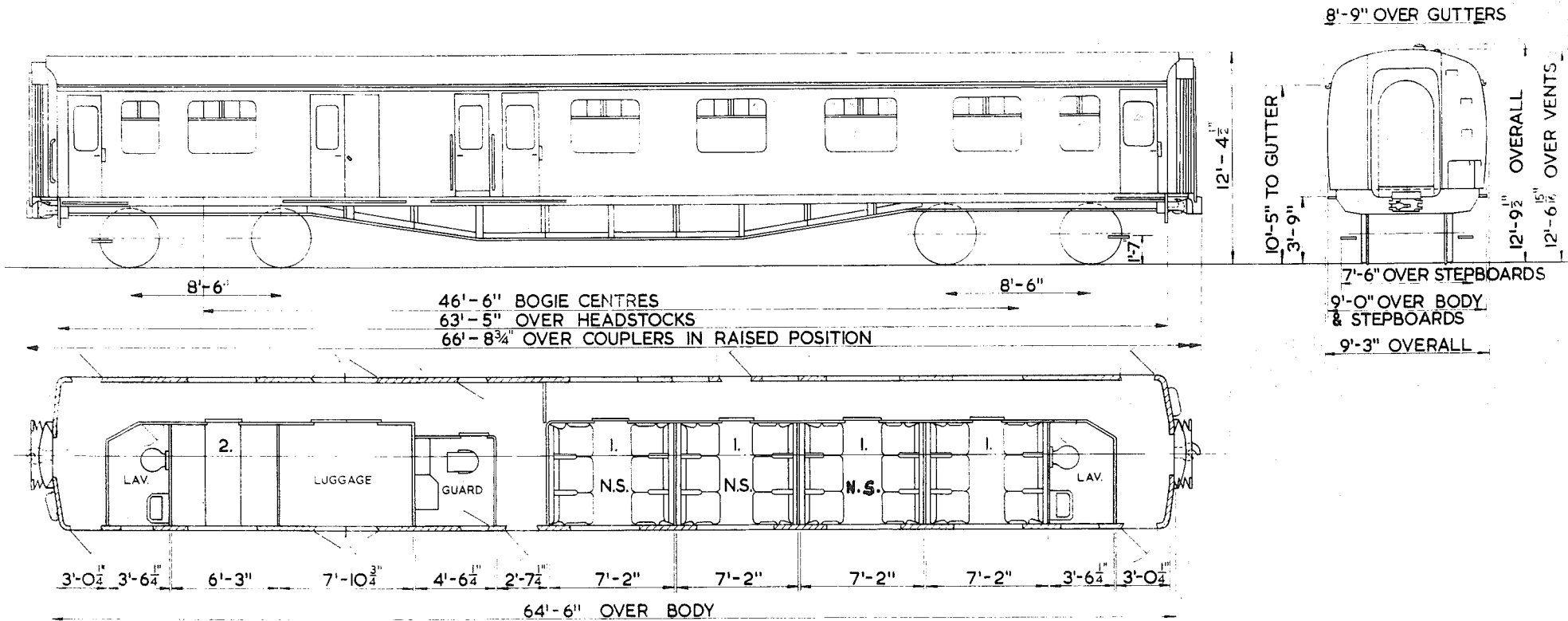

- | | |
|---------------------|-------------------------------|
| SEATS | 24 FIRST CLASS 6 SECOND CLASS |
| TOILETS | 2 |
| COMPARTMENTS | 4 FIRST CLASS 1 SECOND CLASS |
| GUARDS COMPARTMENTS | 1 |
| VENTILATION | - |
| CATERING EQUIPMENT | - |

ORIGINAL DIAGRAMS FOR REFERENCE:-
BR 921

ISSUE 2 DATE NOV '84

EJ 360

BRAKES
BOGIE/SUSPENSION
BODY CONSTRUCTION
COUPLINGS
TRAIN HEATING
MAX.SPEED M.P.H.
MIN.RAD.CURVE CHAINS
LIGHTING
TARE WEIGHT TONNES
GANGWAYS
TRAIN COMMUNICATION
BUFFERS
S.R.DESIGN REFERENCE CODE

BASIC TYPE

ELECTRO PNEUMATIC
COMMONWEALTH
STEEL
AUTOMATIC SOLID SHANK(ALLIANCE NO 2)
ELECTRIC(BR)
90
3.5
FLUORESCENT & TUNGSTEN
31.5
EXPRESS ELECTRIC
DRIVER/GUARD-PUBLIC ADDRESS
NOT FITTED
BW

ALTERNATIVES

TRACTION DATA FOR MULTIPLE UNITS

EMU- INTRODUCED AS CLASS 411/2 1958, RE FURBISHED AS PROTOTYPE & RECLASSED 1975.
VOLTAGE 750/850 VOLTS D.C. THIRD RAIL

BASIC TYPE

EJ 360 0A

VARIANTS

NONE

TRAILER BRAKE COMPOSITE

CLASS 412
411/5

TBC

EJ 361

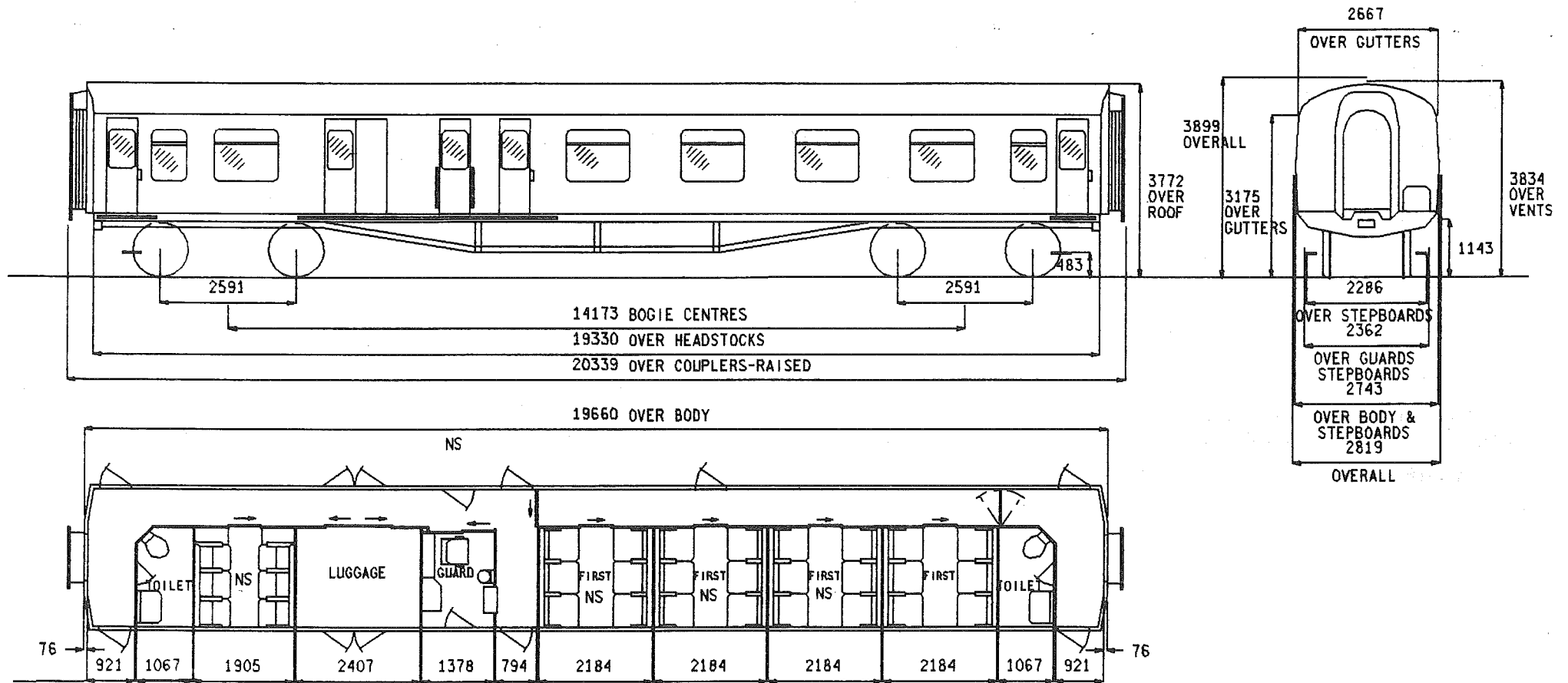

SEATS	24 FIRST CLASS 6 SECOND CLASS
TOILETS	2
COMPARTMENTS	4 FIRST CLASS 1 SECOND CLASS
GUARDS COMPARTMENTS	1
VENTILATION	-
CATERING EQUIPMENT	-

ORIGINAL DIAGRAMS FOR REFERENCE:-
BR 922

ISSUE DATE
6 NOV 84

EJ 361

BASIC TYPE

BRAKES
BOGIE/SUSPENSION
BODY CONSTRUCTION
COUPLINGS
TRAIN HEATING
MAX.SPEED M.P.H.
MIN.RAD.CURVE CHAINS
LIGHTING
TARE WEIGHT TONNES
GANGWAYS
TRAIN COMMUNICATION
BUFFERS
S.R.DESIGN REFERENCE CODE

ELECTRO PNEUMATIC
COMMONWEALTH
STEEL
AUTOMATIC SOLID SHANK (ALLIANCE NO.2)
ELECTRIC (BR)
90
3.5
TUNGSTEN
31.5
EXPRESS ELECTRIC
DRIVER/GUARD-PUBLIC ADDRESS WITH TRANSMITTER
NOT FITTED
BY

ALTERNATIVES

BW, BW 1A, BN 1B

TRACTION DATA FOR MULTIPLE UNITS

EMU- INTRODUCED-CLASS 410/2 1959-CLASS 411/2 1958-REFURBISHED 1980.411/1&/2 RECLASSIFIED 411/5 1983.410/1 & /2 RELASSIFIED 412 1984.
VOLTAGE 750/850 VOLTS D.C. THIRD RAIL

BASIC TYPE

EJ 361 0A-REFURBISHED

VARIANTS

1A REFURBISHED-S.R.DESIGN REFERENCE CODE BW.
2A REFURBISHED-S.R.DESIGN REFERENCE CODE BW 1A.
3A REFURBISHED-S.R.DESIGN REFERENCE CODE BN 1B.

TRAILER BUFFET SECOND

CLASS 422/1
422/2

TRBS

EN 260

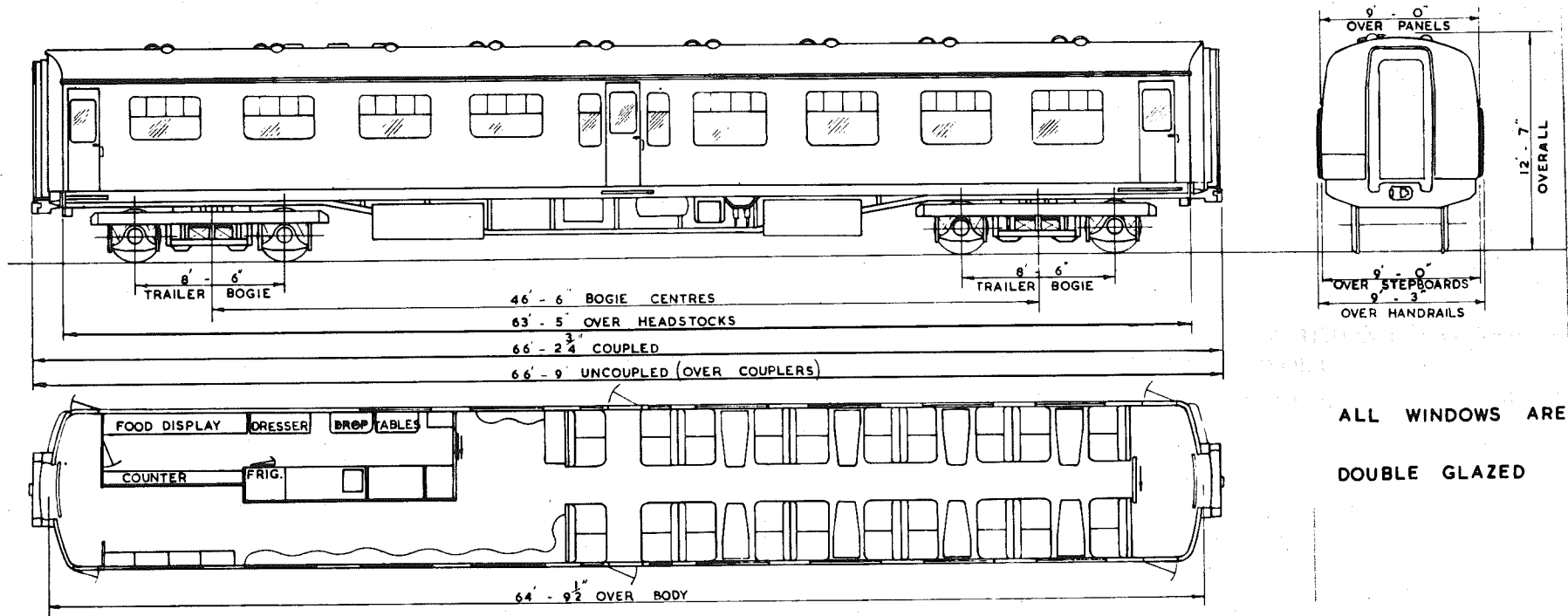

ALL WINDOWS ARE
DOUBLE GLAZED

SEATS	40
TOILETS	-
COMPARTMENTS	-
GUARDS COMPARTMENTS	-
VENTILATION	-
CATERING EQUIPMENT	ELECTRIC

ORIGINAL DIAGRAMS FOR REFERENCE:-
BR 427

ISSUE 3 DATE JAN 84

EN 260

BASIC TYPE

BRAKES
BOGIE/SUSPENSION
BODY CONSTRUCTION
COUPLINGS
TRAIN HEATING
MAX.SPEED M.P.H.
MIN.RAD.CURVE CHAINS
LIGHTING
TARE WEIGHT TONNES
GANGWAYS
TRAIN COMMUNICATION
BUFFERS
S.R.DESIGN REFERENCE CODE

ELECTRO PNEUMATIC
B5(S.R.)
STEEL
AUTOMATIC SOLID SHANK(ALLIANCE NO 2)
ELECTRIC(BR)
90
3.5
TUNGSTEN
35
EXPRESS ELECTRIC
NOT FITTED
NOT FITTED
BP

ALTERNATIVES

FLUORESCENT & TUNGSTEN

BP 1A

TRACTION DATA FOR MULTIPLE UNITS

EMU- INTRODUCED CLASS 420/1 1965 CLASS 420/2 1970-CLASS 420 RECLASSIFIED 1984.
VOLTAGE 750/850 VOLTS D.C.THIRD RAIL

BASIC TYPE

EN 260 0A

VARIANTS

1B FLUORESCENT & TUNGSTEN LIGHTING,S.R.DESIGN REF.CODE BP 1A.

TRAILER BUFFET SECOND

CLASS 412

TRB

EN 261

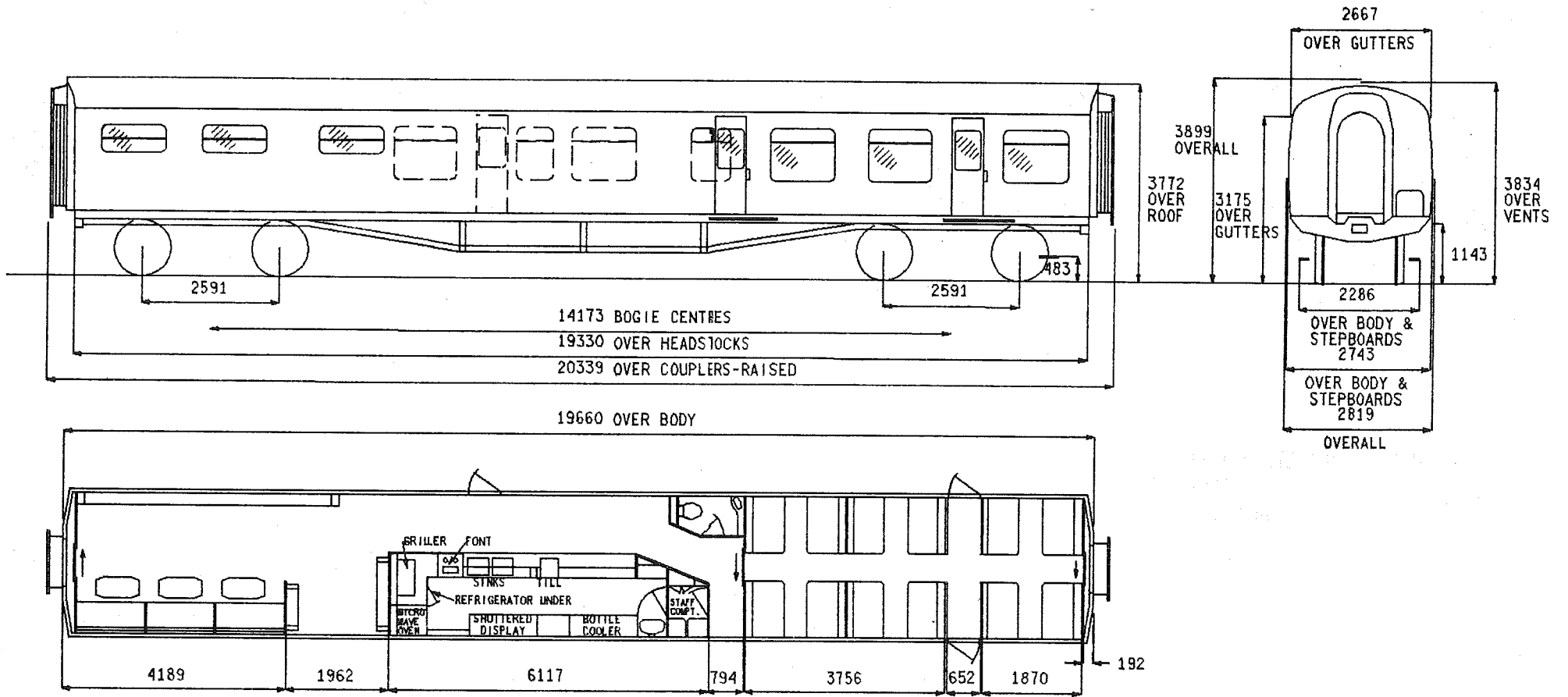

SEATS	33
TOILETS	1
COMPARTMENTS	-
GUARDS COMPARTMENTS	-
VENTILATION	-
CATERING EQUIPMENT	ELECTRIC

ISSUE 2 DATE JAN 84

EN 261

BRAKES
BOGIE/SUSPENSION
BODY CONSTRUCTION
COUPLINGS
TRAIN HEATING
MAX.SPEED M.P.H.
MIN.RAD.CURVE CHAINS
LIGHTING
TARE WEIGHT TONNES
GANGWAYS
TRAIN COMMUNICATION
BUFFERS
S.R.DESIGN REFERENCE CODE

BASIC TYPE

ELECTRO PNEUMATIC
COMMONWEALTH
STEEL
AUTOMATIC SOLID SHANK (ALLIANCE NO.2)
ELECTRIC (BR)
90
3.5
FLUORESCENT & TUNGSTEN
35.5
EXPRESS ELECTRIC
PUBLIC ADDRESS WITH TRANSMITTER
NOT FITTED
BL 3C

ALTERNATIVES

TRACTION DATA FOR MULTIPLE UNITS

EMU- INTRODUCED 1951-REFURBISHED 1980-81, RECLASSIFIED 1984.
VOLTAGE 750/850 VOLTS D.C. THIRD RAIL

BASIC TYPE

EN 261 0A

VARIANTS

NONE

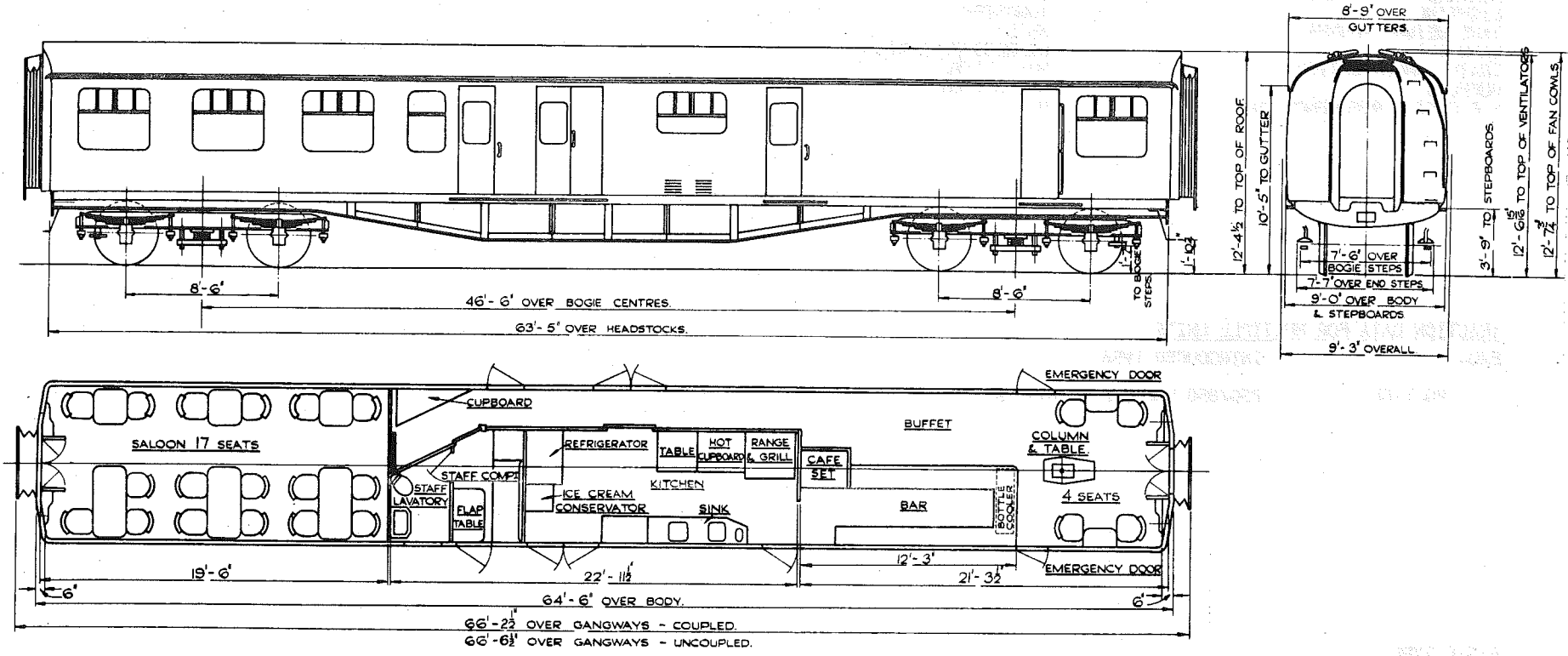

SEATS	21
TOILETS	1
COMPARTMENTS	-
GUARDS COMPARTMENTS	-
VENTILATION	-
CATERING EQUIPMENT	ELECTRIC

ORIGINAL DIAGRAMS FOR REFERENCE:-
BR 425

ISSUE 2 DATE MAY '81

EN 460

BASIC TYPE

BRAKES
BOGIE/SUSPENSION
BODY CONSTRUCTION
COUPLINGS
TRAIN HEATING
MAX. SPEED M.P.H.
MIN. RAD. CURVE CHAINS
LIGHTING
TARE WEIGHT TONNES
GANGWAYS
TRAIN COMMUNICATION
BUFFERS
S.R. DESIGN REFERENCE CODE

ELECTRO PNEUMATIC
COMMONWEALTH
STEEL
AUTOMATIC SOLID SHANK (ALLIANCE NO 2)
ELECTRIC (BR)
90
3.5
TUNGSTEN
35.5
EXPRESS ELECTRIC
NOT FITTED
NOT FITTED
BG

ALTERNATIVES

TRACTION DATA FOR MULTIPLE UNITS

EMU- INTRODUCED 1956.
VOLTAGE 750/850 VOLTS D.C. THIRD RAIL

BASIC TYPE

EN 460 0A

VARIANTS

NONE

TRAILER BUFFET-UNCLASSSED

CLASS 410/2

TRB

EN 461

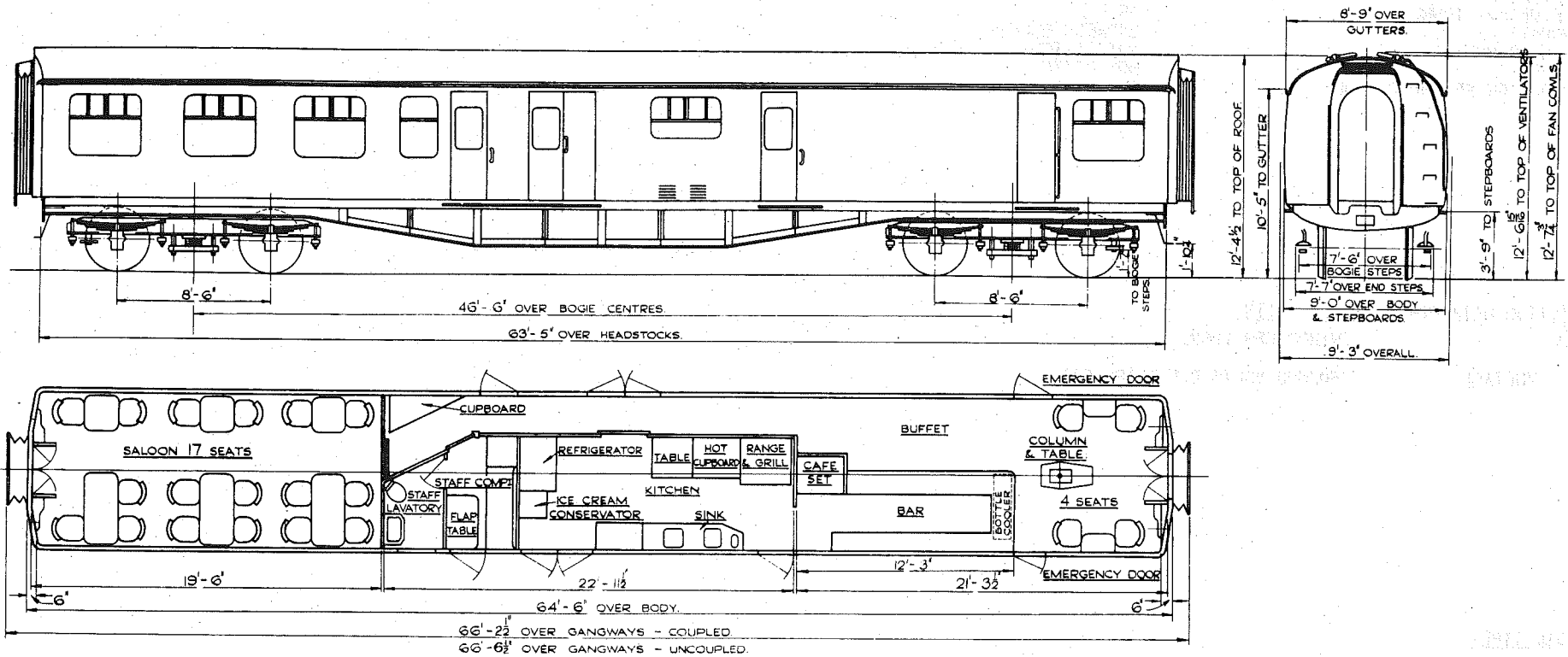

SEATS	21
TOILETS	1
COMPARTMENTS	-
GUARDS COMPARTMENTS	-
VENTILATION	-
CATERING EQUIPMENT	ELECTRIC

ORIGINAL DIAGRAMS FOR REFERENCE.-
BR 425

ISSUE 1 DATE SEP' 80

EN 461

BRAKES
BOGIE/SUSPENSION
BODY CONSTRUCTION
COUPLINGS
TRAIN HEATING
MAX. SPEED M.P.H.
MIN. RAD. CURVE CHAINS
LIGHTING
TARE WEIGHT TONNES
GANGWAYS
TRAIN COMMUNICATION
BUFFERS
S.R. DESIGN REFERENCE CODE

BASIC TYPE

ELECTRO PNEUMATIC
COMMONWEALTH
STEEL
AUTOMATIC SOLID SHANK (ALLIANCE NO.2)
ELECTRIC (BR)
90
3.5
ELECTRIC
35.5
EXPRESS ELECTRIC
NOT FITTED
NOT FITTED
BL

ALTERNATIVES

BL 1A, BL 2B

TRACTION DATA FOR MULTIPLE UNITS

EMU- INTRODUCED 1959.
VOLTAGE 750/850 VOLTS D.C. THIRD RAIL

BASIC TYPE

EN 461 0A

VARIANTS

1B S.R. DESIGN REFERENCE CODE BL 1A.
2C S.R. DESIGN REFERENCE CODE BL 2B.

TRAILER BUFFET-UNCLASSED

CLASS 432

TRB

EN 462

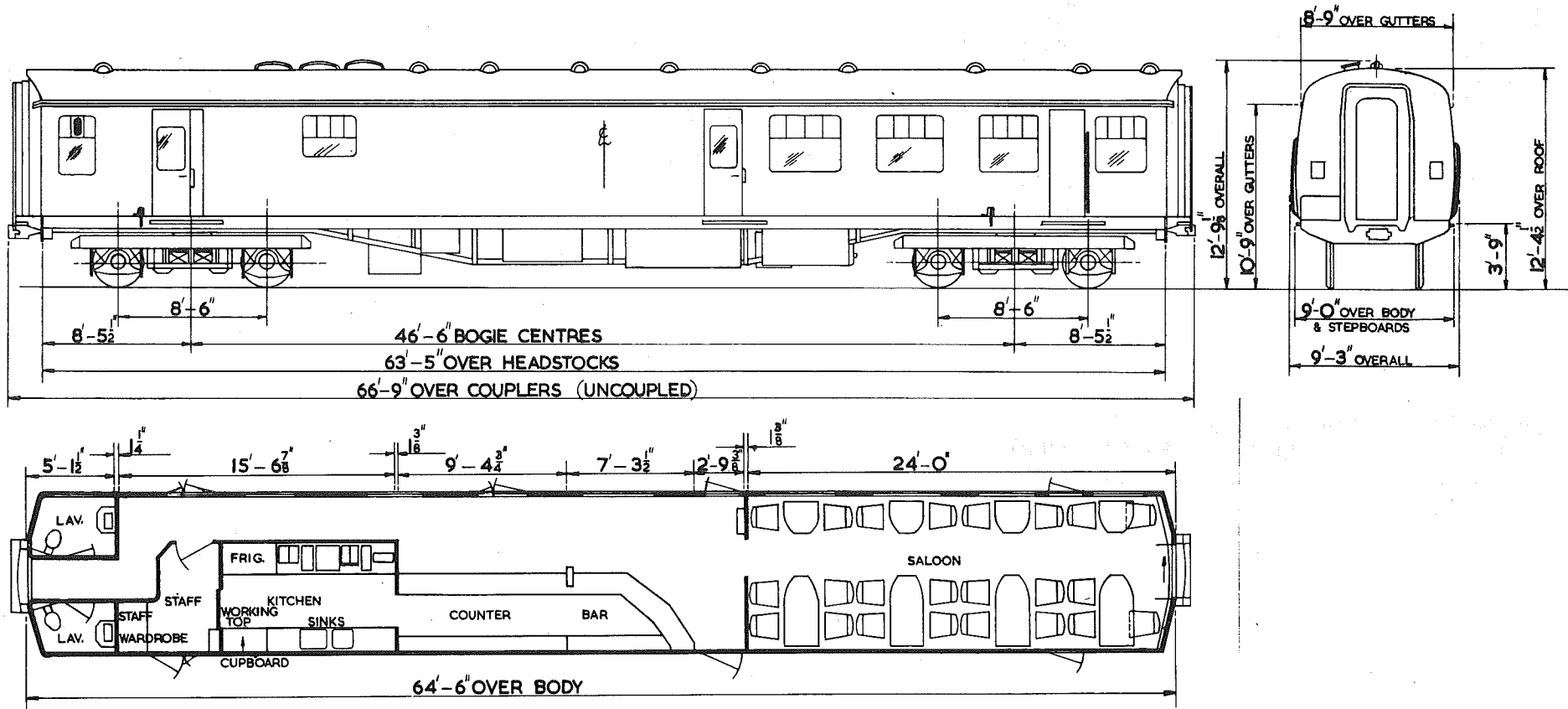

SEATS	23
TOILETS	2
COMPARTMENTS	-
GUARDS COMPARTMENTS	-
VENTILATION	-
CATERING EQUIPMENT	ELECTRIC

ORIGINAL DIAGRAMS FOR REFERENCE:-
BR 940

ISSUE 2 DATE JAN 84

EN 462

BASIC TYPE

BRAKES
BOGIE/SUSPENSION
BODY CONSTRUCTION
COUPLINGS
TRAIN HEATING
MAX.SPEED M.P.H.
MIN.RAD.CURVE CHAINS
LIGHTING
TARE WEIGHT TONNES
GANGWAYS
TRAIN COMMUNICATION
BUFFERS
S.R.DESIGN REFERENCE CODE

ELECTRO PNEUMATIC
B5(S.R.)
STEEL
AUTOMATIC SOLID SHANK (ALLIANCE NO.2)
ELECTRIC (BR)
90
3.5
TUNGSTEN
35
EXPRESS ELECTRIC
NOT FITTED
NOT FITTED
BS

ALTERNATIVES

TRACTION DATA FOR MULTIPLE UNITS

EMU- INTRODUCED 1966, RECLASSIFIED 1984.
VOLTAGE 750/850 VOLTS D.C. THIRD RAIL

BASIC TYPE

EN 462 0A

VARIANTS

NONE

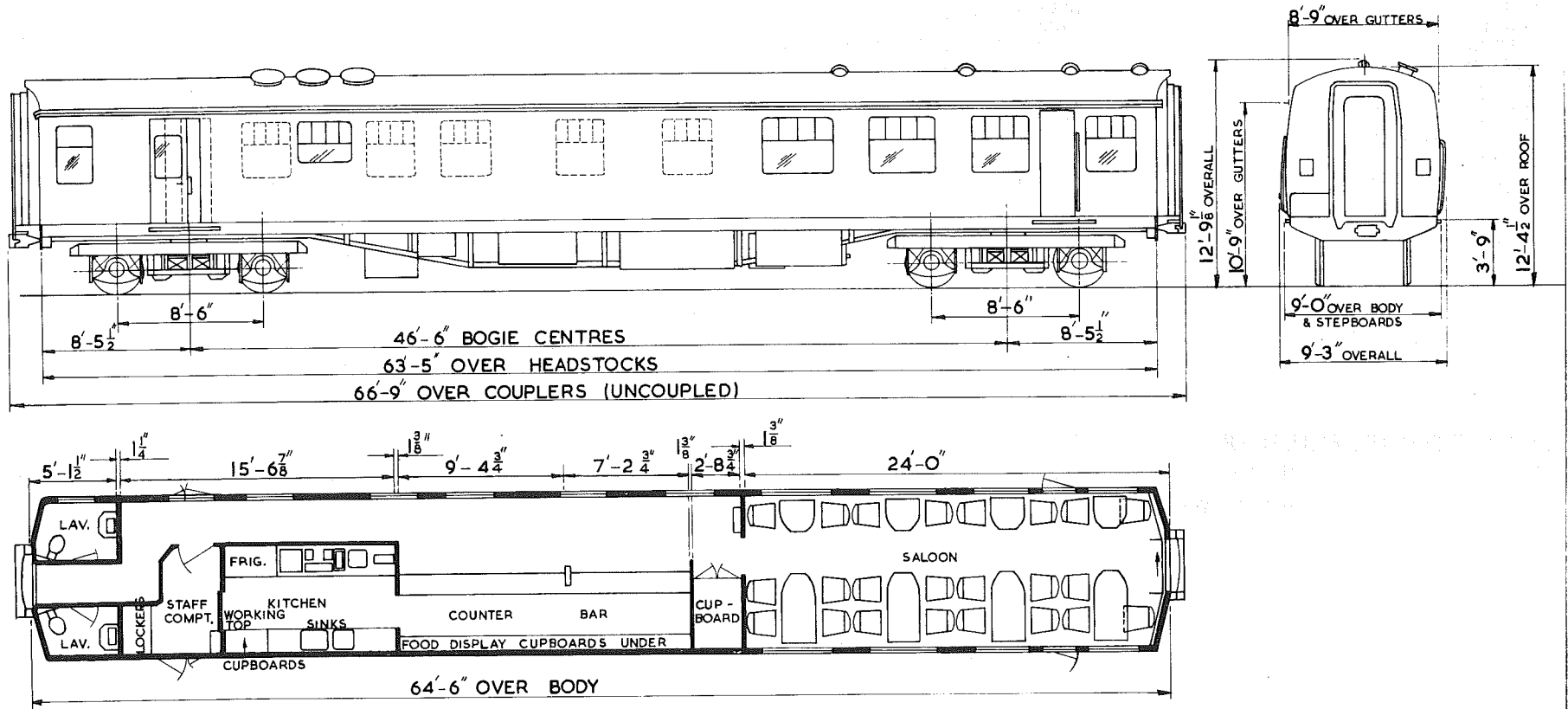

SEATS	23
TOILETS	2
COMPARTMENTS	-
GUARDS COMPARTMENTS	-
VENTILATION	-
CATERING EQUIPMENT	ELECTRIC

ORIGINAL DIAGRAMS FOR REFERENCE:-
BR 941

ISSUE 3 DATE JAN 84

EN 463

BRAKES
BOGIE/SUSPENSION
BODY CONSTRUCTION
COUPLINGS
TRAIN HEATING
MAX.SPEED M.P.H.
MIN.RAD.CURVE CHAINS
LIGHTING
TARE WEIGHT TONNES
GANGWAYS
TRAIN COMMUNICATION
BUFFERS
S.R.DESIGN REFERENCE CODE

BASIC TYPE

ELECTRO PNEUMATIC
B5(S.R.)
STEEL
AUTOMATIC SOLID SHANK(ALLIANCE NO.2)
ELECTRIC(BR)
90
3.5
TUNGSTEN
35
EXPRESS ELECTRIC
NOT FITTED
NOT FITTED
BS 1A

ALTERNATIVES

TRACTION DATA FOR MULTIPLE UNITS

EMU- INTRODUCED 1974, RECLASSIFIED 1984.
VOLTAGE 750/850 VOLTS D.C. THIRD RAIL

BASIC TYPE

EN 463 0A

VARIANTS

NONE

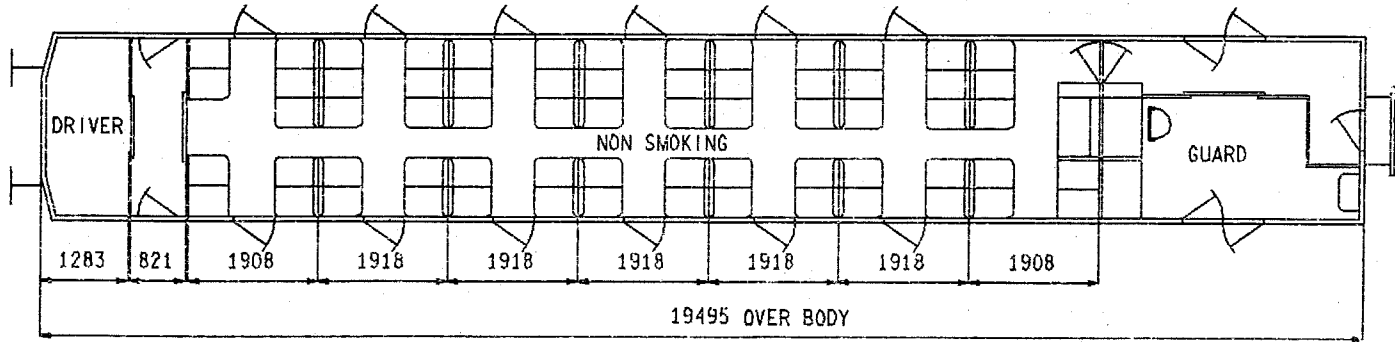
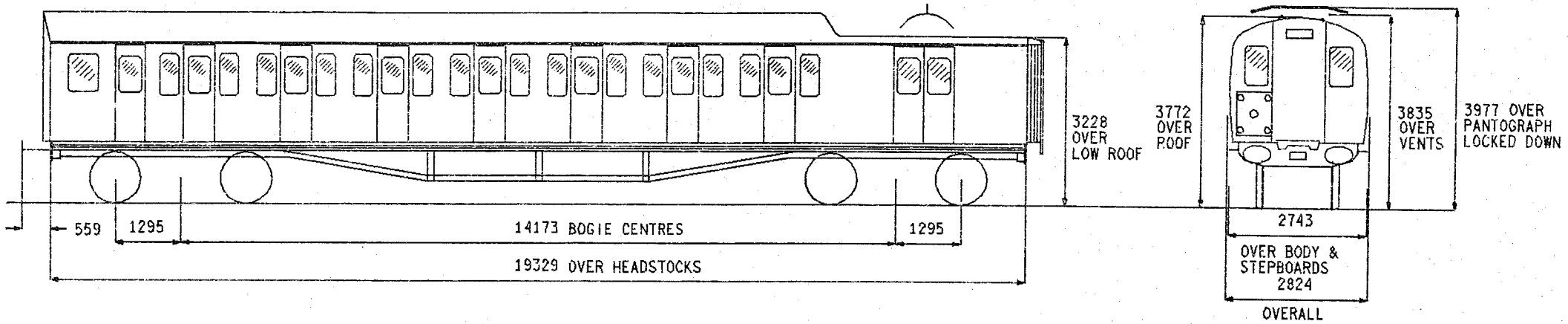

SEATS	66
TOILETS	-
COMPARTMENTS	-
GUARDS COMPARTMENTS	1
VENTILATION	-
CATERING EQUIPMENT	-

ISSUE 2 DATE MAR 87

EO 202

BRAKES
BOGIE/SUSPENSION
BODY CONSTRUCTION
COUPLINGS

TRAIN HEATING
MAX. SPEED M.P.H.
MIN. RAD. CURVE CHAINS
LIGHTING
TARE WEIGHT TONNES
GANGWAYS
A.W.S.
TRAIN COMMUNICATION
BUFFERS

BASIC TYPE

ELECTRO PNEUMATIC
ET7
STEEL
AUTOMATIC DROPHEAD(BUCKEYE) OUTER END-AUTOMATIC SOLID SHANK
(BUCKEYE) INNER END
ELECTRIC(BR)
75
3.5
FLUORESCENT
43
PULLMAN WITH RIGID(GRP) INNER PANELS INNER END ONLY
FITTED
DRIVER/GUARD-PUBLIC ADDRESS WITH TRANSMITTER
RETRACTABLE SPINDLE-559 X 356 OVAL OUTER END-CENTRE INNER END

ALTERNATIVES

B5

TRACTION DATA FOR MULTIPLE UNITS

GREAT EASTERN OUTER SUBURBAN. INTRODUCED 1956 FOR D.C.WORKING, REBUILT 1962 FOR A.C.WORKING, REFURBISHED 1981.
25 & 6.25 KV A.C.OVERHEAD

BASIC TYPE

EO 202 0A

VARIANTS

OB B5 BOGIES.

TRAILER FIRST HANDBRAKE

CLASS 488/2

TFH

EP 101

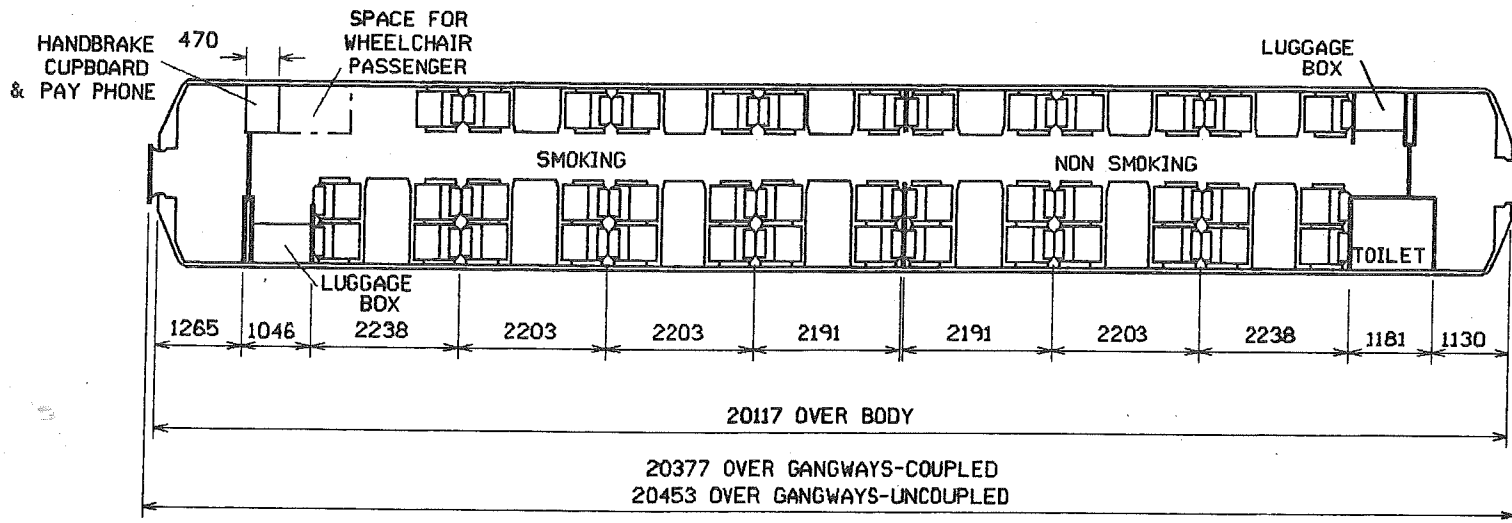
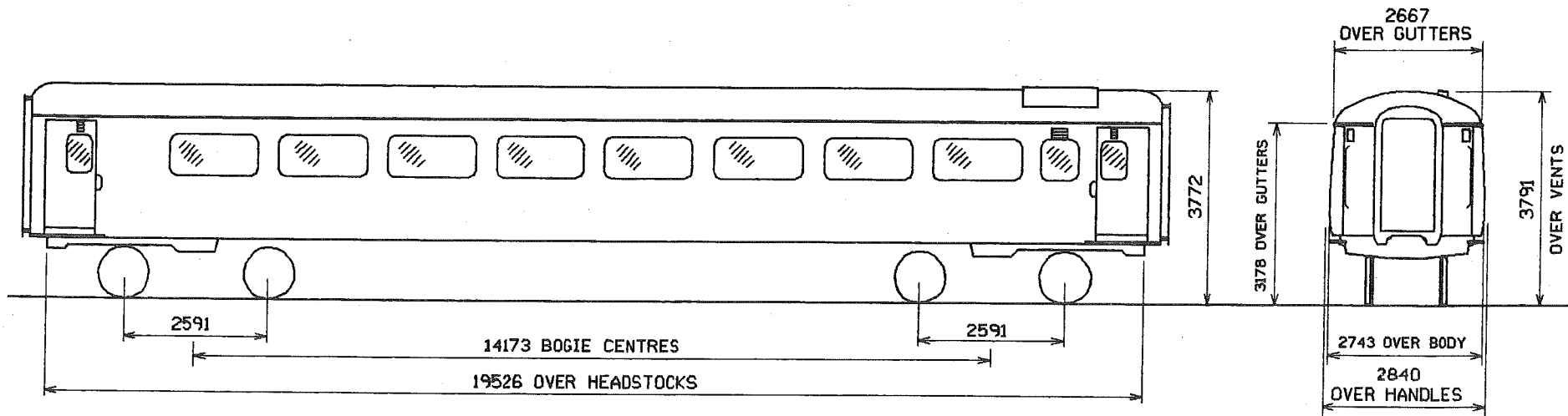

SEATS	41
TOILETS	1
COMPARTMENTS	-
GUARDS COMPARTMENTS	-
VENTILATION	FULL AIR CONDITIONING
CATERING EQUIPMENT	-

ISSUE 2 DATE JUN 86

EP 101

BRAKES
BOGIE/SUSPENSION
BODY CONSTRUCTION
COUPLINGS
TRAIN HEATING
MAX SPEED M.P.H.
MIN.RAD.CURVE CHAINS
LIGHTING
TARE WEIGHT TONNES
GANGWAYS
TRAIN COMMUNICATION
BUFFERS

BASIC TYPE

ELECTRO-PNEUMATIC
B4
STEEL
AUTOMATIC DROPHEAD(BUCKEYE) OUTER END-BAR INNER END
ELECTRIC(BR)FULL AIR CONDITIONING
90
3.5
FLUORESCENT & TUNGSTEN
35(ESTIMATED)
PULLMAN
PUBLIC ADDRESS
RETRACTABLE SPINDLE (559X356 OVAL) OUTER END ONLY

ALTERNATIVES

PUBLIC ADDRESS & PAY PHONE

TRACTION DATA FOR MULTIPLE UNITS

EMU- VICTORIA-GATWICK CONVERTED MK IIF INTRODUCED 1984.
VOLTAGE 750 VOLTS D.C.THIRD RAIL

BASIC TYPE

EP 101 0A

VARIANTS

1A PUBLIC ADDRESS & PAY PHONE.

TRAILER SECOND HANDBRAKE

CLASS 488/2
488/3

TSH

EP 201

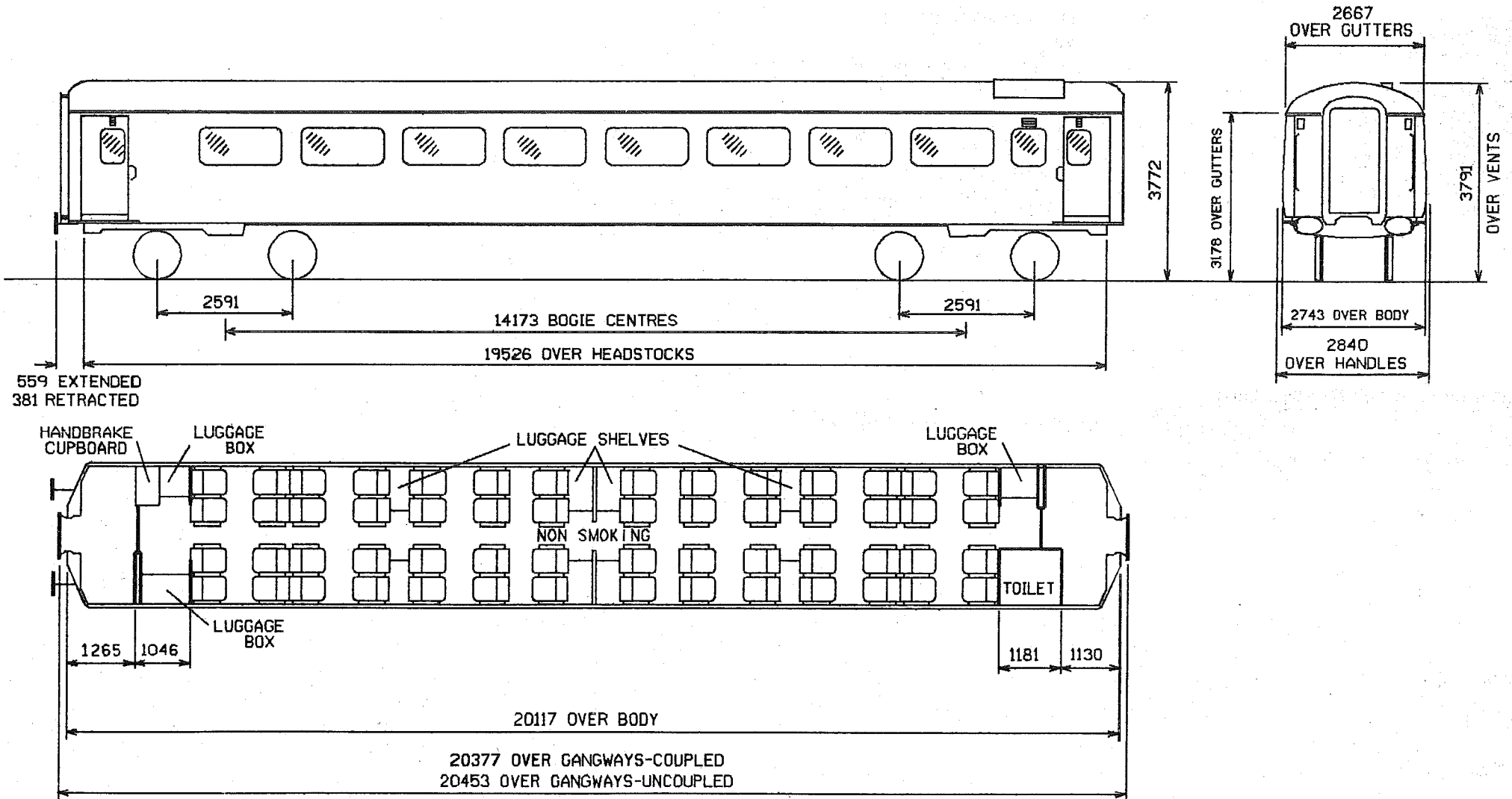

SEATS	56
TOILETS	1
COMPARTMENTS	-
GUARDS COMPARTMENTS	-
VENTILATION	FULL AIR CONDITIONING
CATERING EQUIPMENT	-

EP 201

BASIC TYPE

ALTERNATIVES

BRAKES
BOGIE/SUSPENSION
BODY CONSTRUCTION
COUPLINGS
TRAIN HEATING
MAX SPEED M.P.H.
MIN.RAD.CURVE CHAINS
LIGHTING
TARE WEIGHT TONNES
GANGWAYS
TRAIN COMMUNICATION
BUFFERS

ELECTRO PNEUMATIC
B4
STEEL
AUTOMATIC DROPHEAD(BUCKEYE) OUTER END-BAR INNER END
ELECTRIC(BR) FULL AIR CONDITIONING
90
3.5
FLUORESCENT & TUNGSTEN
35(ESTIMATED)
PULLMAN
PUBLIC ADDRESS
RETRACTABLE SPINDLE(559X356 OVAL) OUTER END ONLY

TRACTION DATA FOR MULTIPLE UNITS

EMU- VICTORIA-GATWICK CONVERTED MK IIF TO BE INTRODUCED
VOLTAGE 750 VOLTS D.C. THIRD RAIL

BASIC TYPE

EP 201 0A

VARIANTS

NONE

BRAKE

CLASS 488/2
488/3

TSH

EP 202

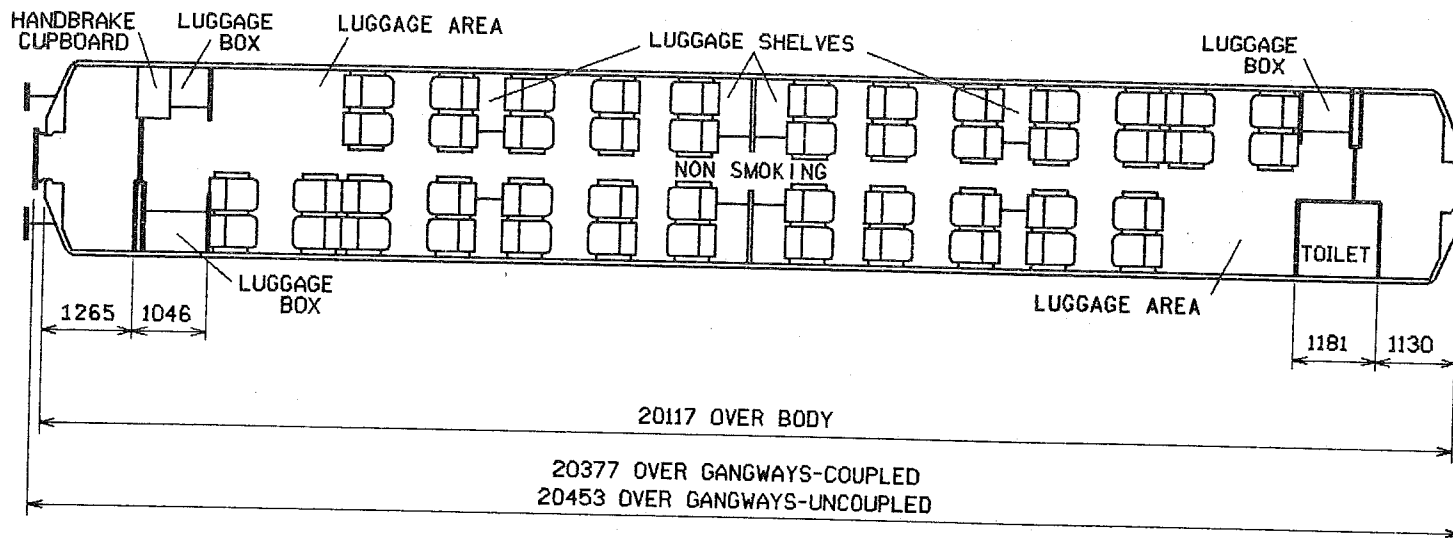
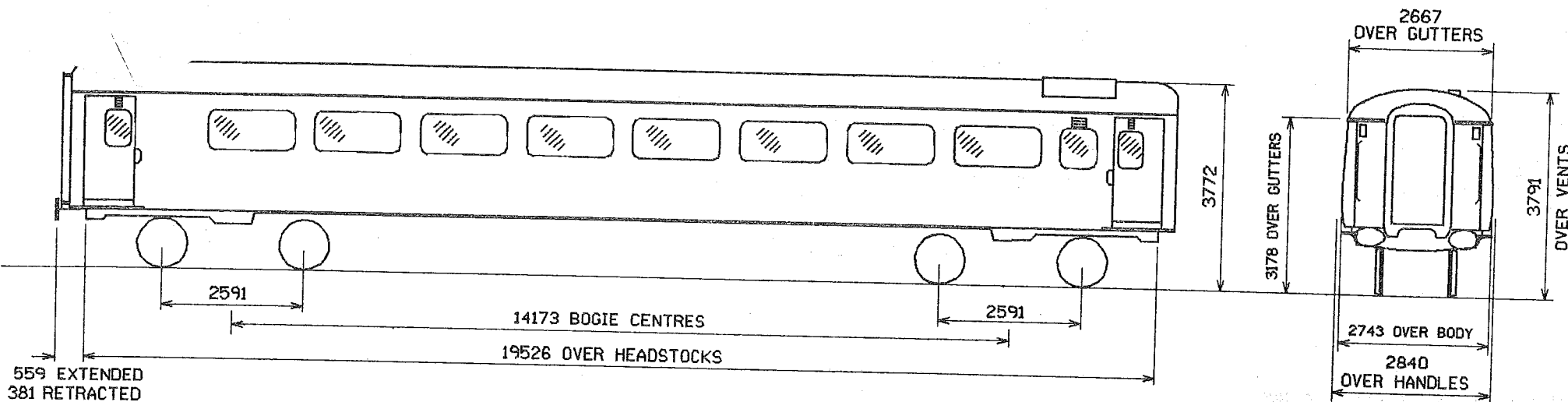

SEATS	48
TOILETS	1
COMPARTMENTS	-
GUARDS COMPARTMENTS	-
VENTILATION	FULL AIR CONDITIONING
CATERING EQUIPMENT	-

EP 202

BASIC TYPE

ALTERNATIVES

BRAKES
BOGIE/SUSPENSION
BODY CONSTRUCTION
COUPLINGS
TRAIN HEATING
MAX SPEED M.P.H.
MIN.RAD.CURVE CHAINS
LIGHTING
TARE WEIGHT TONNES
GANGWAYS
TRAIN COMMUNICATION
BUFFERS

ELECTRO PNEUMATIC
B4
STEEL
AUTOMATIC DROPHEAD(BUCKEYE) OUTER END-BAR INNER END
ELECTRIC(BR) FULL AIR CONDITIONING
90
3.5
FLUORESCENT & TUNGSTEN
35(ESTIMATED)
PULLMAN
PUBLIC ADDRESS
RETRACTABLE SPINDLE(559X356 OVAL) OUTER END ONLY

TRACTION DATA FOR MULTIPLE UNITS

EMU- VICTORIA-GATWICK CONVERTED MK IIF INTRODUCED 1984
VOLTAGE 750 VOLTS D.C. THIRD RAIL

BASIC TYPE

EP 202 0A

VARIANTS

NONE

DRIVING TRAILER LUGGAGE VAN

CLASS 308/2

DTLV

EW 501

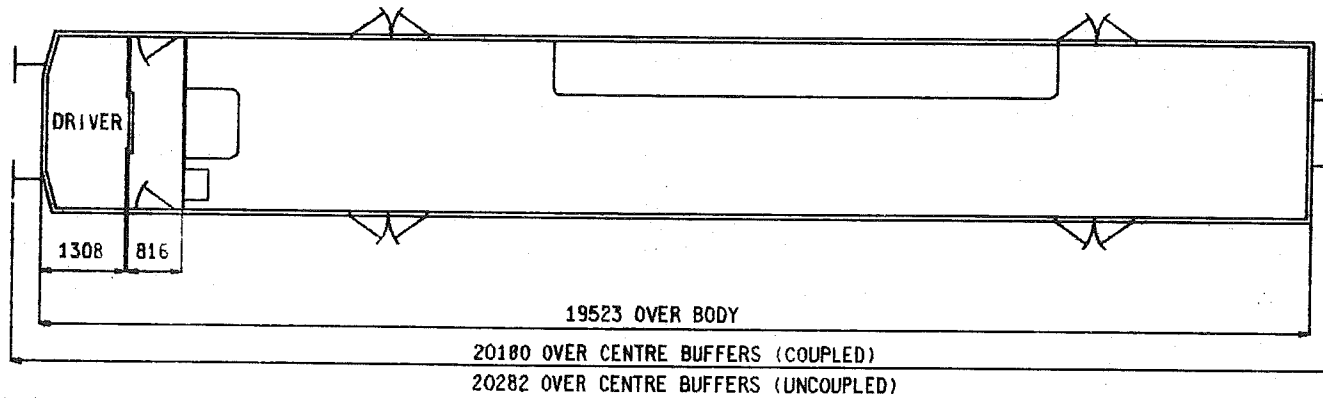
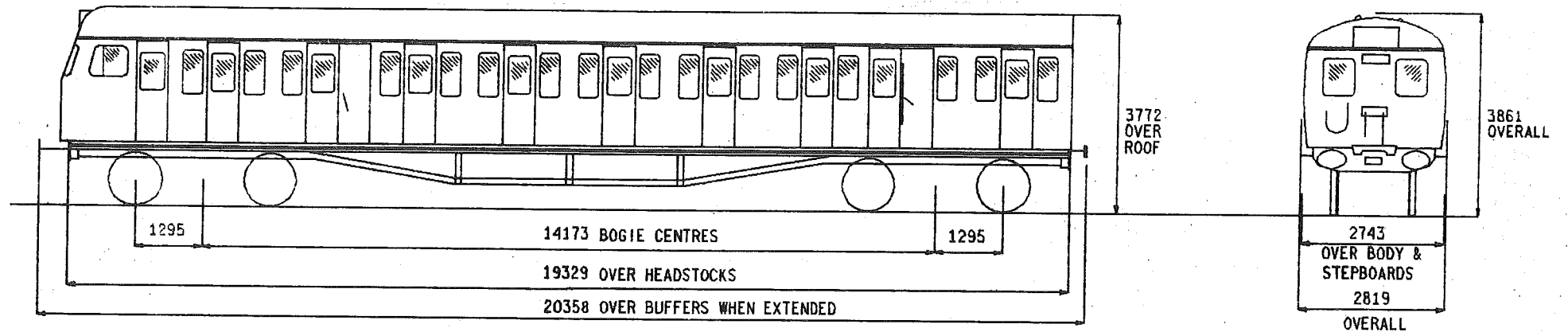

- SEATS -
- TOILETS -
- COMPARTMENTS -
- GUARDS COMPARTMENTS -
- VENTILATION -
- CATERING EQUIPMENT -

ISSUE 1 DATE MAY 84

EW 501

BRAKES
BOGIE/SUSPENSION
BODY CONSTRUCTION
COUPLINGS

TRAIN HEATING
MAX.SPEED M.P.H.
MIN.RAD.CURVE CHAINS
LIGHTING
TARE WEIGHT TONNES
GANGWAYS
A.W.S.
TRAIN COMMUNICATION
BUFFERS

BASIC TYPE

ELECTRO PNEUMATIC
GRESLEY ET8
STEEL
AUTOMATIC DROPHEAD(BUCKEYE) OUTER END-AUTOMATIC SOLID SHANK
(ALLIANCE NO.2) INNER END
ELECTRIC(BR)
75
3.5
TUNGSTEN
32
NOT FITTED
FITTED
NOT FITTED
RETRACTABLE SPINDLE-559 X 356 OVAL OUTER END ONLY

ALTERNATIVES

GRESLEY ET8

TRACTION DATA FOR MULTIPLE UNITS

EMU- LIVERPOOL ST.-ENFIELD & CHINGFORD. INTRODUCED 1961 MODIFIED 1984.
VOLTAGE 25 & 6.25 KV A.C.OVERHEAD

BASIC TYPE

EW 501 0A

VARIANTS

NONE

DRIVING MOTOR LUGGAGE VAN

CLASS 419

DMLV

EX 560

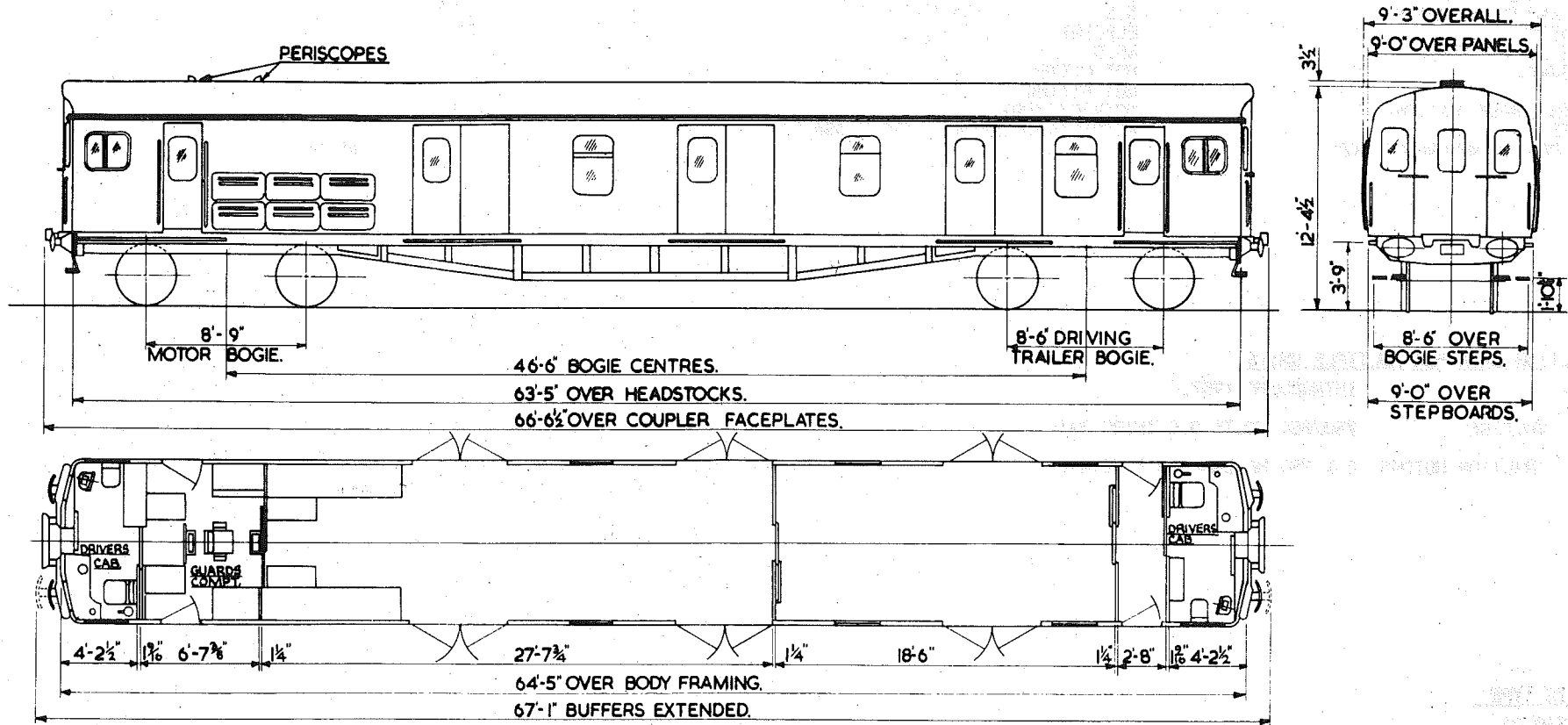

- SEATS -
- TOILETS -
- COMPARTMENTS -
- GUARDS COMPARTMENTS -
- VENTILATION -
- CATERING EQUIPMENT -

ORIGINAL DIAGRAMS FOR REFERENCE.
BR 498

ISSUE DATE
1 SEP' 80

EX 560

BASIC TYPE

BRAKES
BOGIE/SUSPENSION
BODY CONSTRUCTION
COUPLINGS
TRAIN HEATING
MAX. SPEED M.P.H.
MIN. RAD. CURVE CHAINS
LIGHTING
TARE WEIGHT TONNES
GANGWAYS
A. V. S.
TRAIN COMMUNICATION
BUFFERS
S.R. DESIGN REFERENCE CODE

ELECTRO PNEUMATIC
S.R. MK 3B POWERED & UNPOWERED (ONE OF EACH)
STEEL
AUTOMATIC DROPHEAD (BUCKEYE)
ELECTRIC (BR)
90
3.5
ELECTRIC
45.5
NOT FITTED
NOT FITTED
DRIVER/GUARD
RETRACTABLE SPINDLE-559 X 356 OVAL
AF

ALTERNATIVES

AF 1A

TRACTION DATA FOR MULTIPLE UNITS

EMU- INTRODUCED 1957.
VOLTAGE 750/850 VOLTS D.C. THIRD RAIL
TRACTION MOTORS 2 X 250 HP ENGLISH ELECTRIC

BASIC TYPE

EX 560 0A

VARIANTS

1B S.R. DESIGN REFERENCE CODE AF 1A.

DRIVING MOTOR LUGGAGE VAN

CLASS 489

DMLV

EX 561

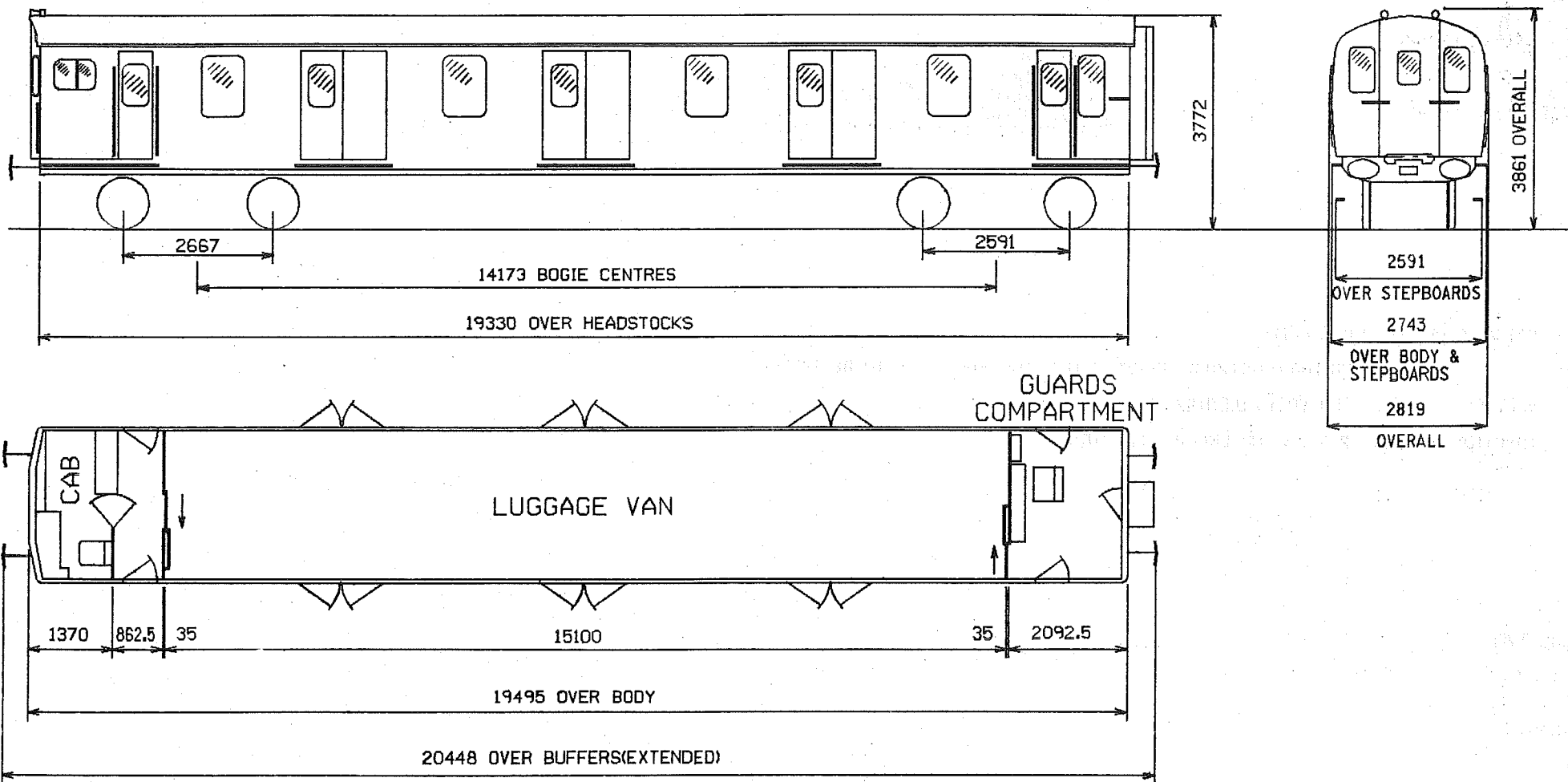

- TOILETS -
- COMPARTMENTS -
- GUARDS COMPARTMENTS 1
- VENTILATION -
- CATERING EQUIPMENT -

EX 561

BASIC TYPE

BRAKES
BOGIE/SUSPENSION
BODY CONSTRUCTION
COUPLINGS
TRAIN HEATING
MAX SPEED M.P.H.
MIN.RAD.CURVE CHAINS
LIGHTING
TARE WEIGHT TONNES
GANGWAYS
TRAIN COMMUNICATION
BUFFERS

ELECTRO PNEUMATIC
SR MK4 POWERED & UNPOWERED(ONE OF EACH)
STEEL
AUTOMATIC DROPHEAD (BUCKEYE)
ELECTRIC(BR)
90
3.5
TUNGSTEN
45 (ESTIMATED)
PULLMAN WITH RIGID GRP INNER PANELS
PUBLIC ADDRESS
RETRACTABLE SPINDLE (559X356 OVAL)

ALTERNATIVES

TRACTION DATA FOR MULTIPLE UNITS

EMU- VICTORIA-GATWICK CONVERTED CLASS 414/3 TO BE INTRODUCED
VOLTAGE 750 VOLTS D.C.THIRD RAIL
TRACTION MOTORS 2 X 250 HP ENGLISH ELECTRIC

BASIC TYPE

EX 561 0A

VARIANTS

NONE

MOTOR LUGGAGE VAN

CLASS 308/2

MLV

EY 501

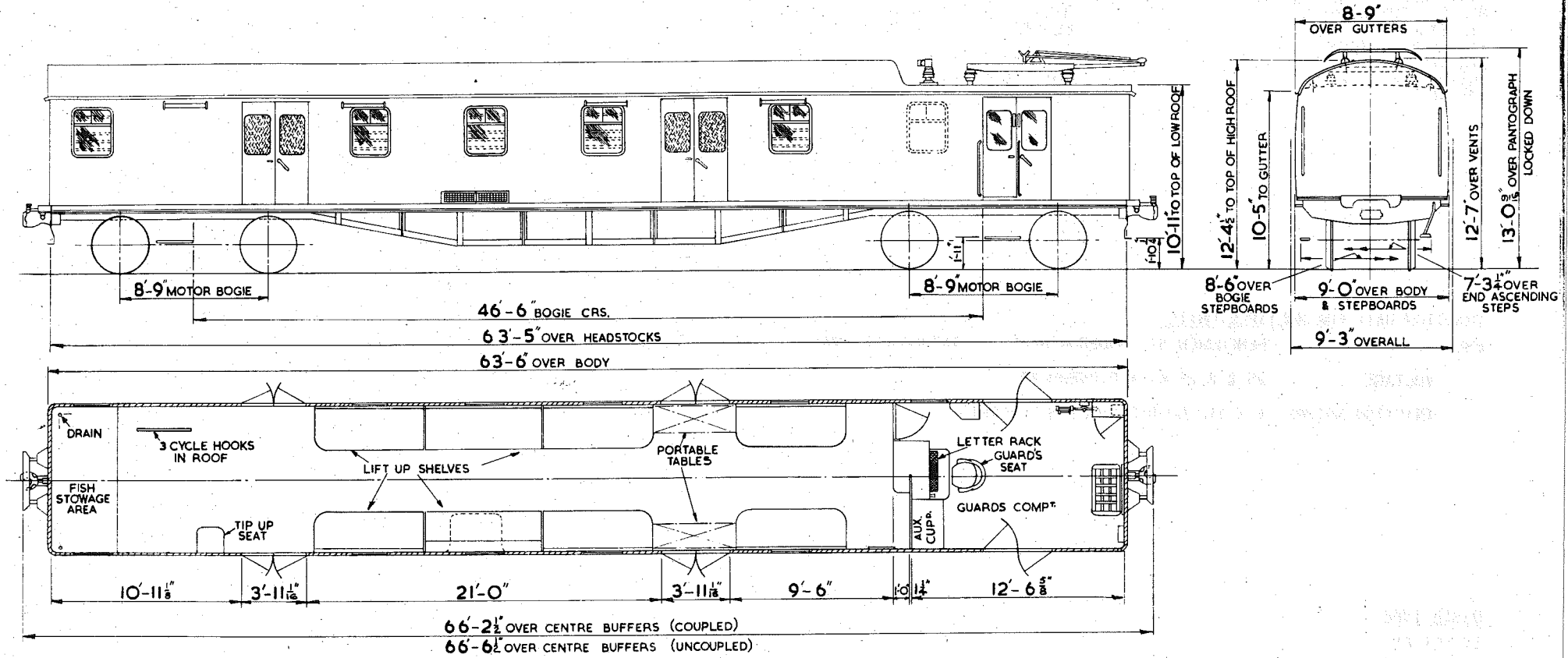

- SEATS - -
- TOILETS - -
- COMPARTMENTS - -
- GUARDS COMPARTMENTS 1
- VENTILATION - -
- CATERING EQUIPMENT - -

ORIGINAL DIAGRAMS FOR REFERENCE.-
BR 497

ISSUE 1 DATE SEP '80

EY 501

BRAKES
BOGIE/SUSPENSION
BODY CONSTRUCTION
COUPLINGS
TRAIN HEATING
MAX. SPEED H.P.H.
MIN. RAD. CURVE CHAINS
LIGHTING
TARE WEIGHT TONNES
GANGWAYS
TRAIN COMMUNICATION
BUFFERS

BASIC TYPE

ELECTRO PNEUMATIC
GRESLEY EDB
STEEL
AUTOMATIC SOLID SHANK (ALLIANCE NO. 2)
ELECTRIC (BR)
75
3.5
ELECTRIC
52
NOT FITTED
NOT FITTED
NOT FITTED

ALTERNATIVES

TRACTION DATA FOR MULTIPLE UNITS

EMU- FENCHURCH ST.-SHOEBURYNNESS. INTRODUCED 1961.
VOLTAGE 25 & 6.25 KV A.C. OVERHEAD
TRACTION MOTORS 4 X 192 HP D.C. ENGLISH ELECTRIC

BASIC TYPE

EY 501 0A

VARIANTS

NONE

MOTOR-APT

CLASS 370

M

LC 501

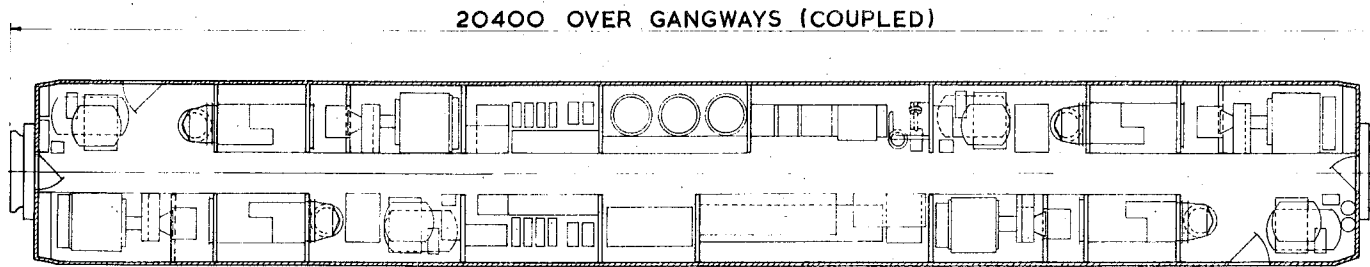
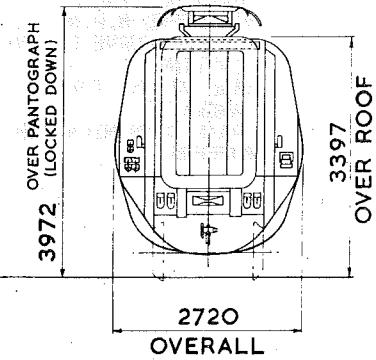
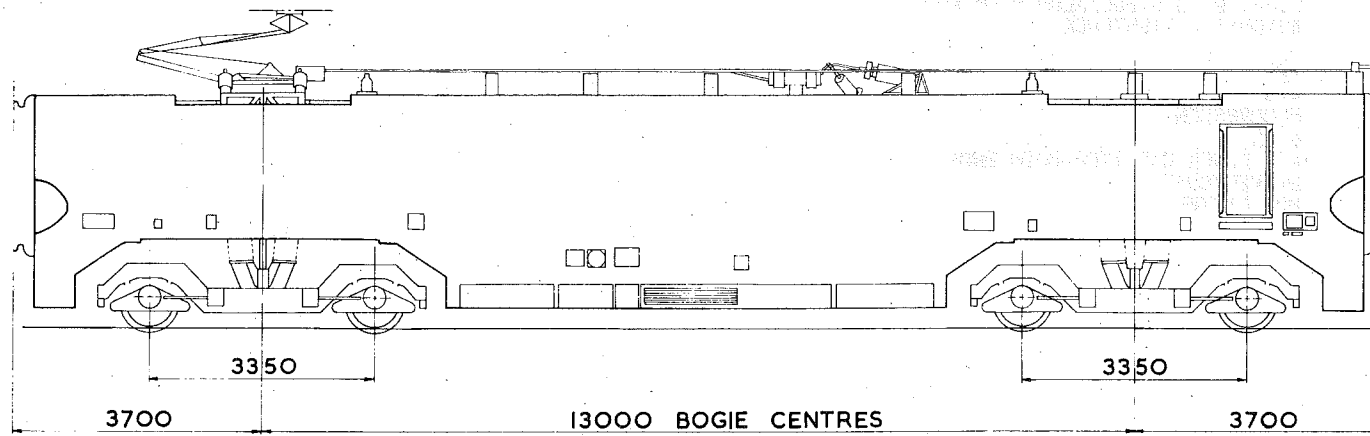

SEATS
TOILETS
COMPARTMENTS
GUARDS COMPARTMENTS
VENTILATION
CATERING EQUIPMENT

ORIGINAL DIAGRAMS FOR REFERENCE.-
BR 883

ISSUE 2 DATE AUG 81

LC 501

BASIC TYPE

BRAKES
BOGIE/SUSPENSION
BODY CONSTRUCTION
COUPLINGS
TRAIN HEATING
MAX. SPEED M.P.H.
MIN. RAD. CURVE CHAINS
LIGHTING
TARE WEIGHT TONNES
GANGWAYS
TRAIN COMMUNICATION
BUFFERS

ELECTRONIC CONTROL (APT)
BP17 & BP17a (ONE OF EACH)
STEEL WITH STEEL/ALUMINIUM ROOF
AUTOMATIC TIGHTLOCK
-
125
4.5
FLUORESCENT
67.5
APT POWER CAR TYPE-BOTH ENDS
DRIVER/GUARD
NOT FITTED

ALTERNATIVES

TRACTION DATA FOR MULTIPLE UNITS

APT PROTOTYPE INTRODUCED 1980.
VOLTAGE 25 KV A.C. OVERHEAD
TRACTION MOTORS 4 X 1000 HP CONTINUOUS RATING-ASEA LUMA 410 F.

BASIC TYPE

LC 501 0A

VARIANTS

NONE

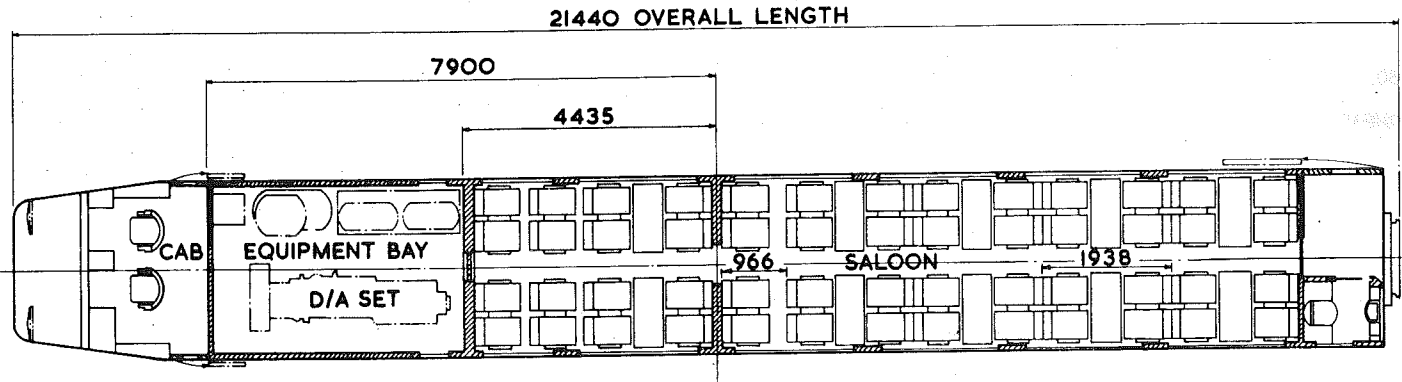
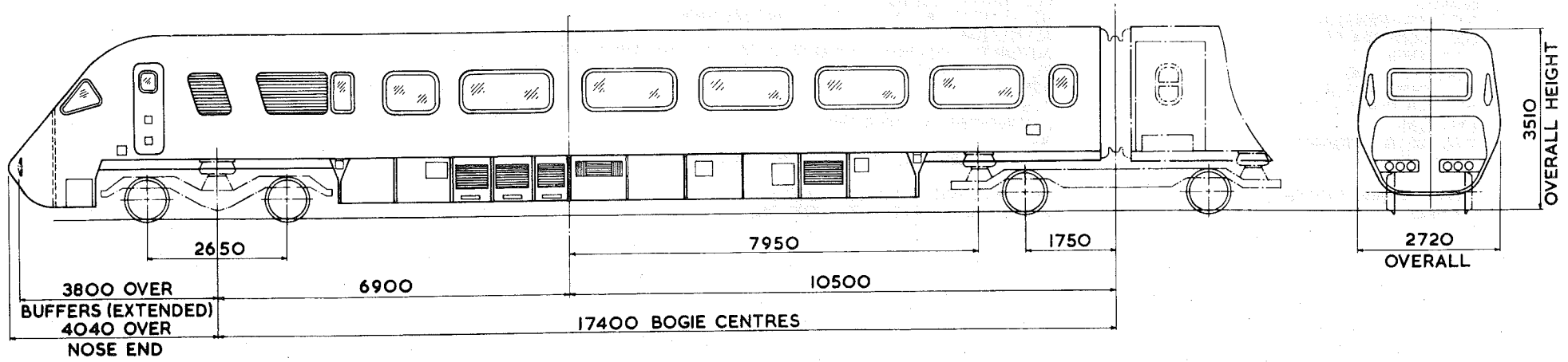

- SEATS 52
- TOILETS 1
- COMPARTMENTS -
- GUARDS COMPARTMENTS -
- VENTILATION FULL AIR CONDITIONING
- CATERING EQUIPMENT -

ORIGINAL DIAGRAMS FOR REFERENCE.-
BR 902

ISSUE 2 DATE AUG 81

LE 201

BRAKES
BOGIE/SUSPENSION
BODY CONSTRUCTION
COUPLINGS
TRAIN HEATING
MAX. SPEED H.P.H.
MIN. RAD. CURVE CHAINS
LIGHTING
TARE WEIGHT TONNES
GANGWAYS
A.V.S.
TRAIN COMMUNICATION
BUFFERS

BASIC TYPE

ELECTRONIC CONTROL (APT)
BT11 (ARTICULATED) & BT12 (ONE OF EACH)
ALUMINIUM
AUTOMATIC DROPHEAD (BUCKEYE) OUTER END-BAR INNER END
ELECTRIC (BR) FULL AIR CONDITIONING
125
4.5
FLUORESCENT & TUNGSTEN
35
APT TRAILER CAR TYPE-ONE END ONLY
FITTED
DRIVER/GUARD & PUBLIC ADDRESS
RETRACTABLE OLEO OUTER END ONLY

ALTERNATIVES

TRACTION DATA FOR MULTIPLE UNITS

APT PROTOTYPE INTRODUCED 1980.
VOLTAGE 25 KV A.C.OVERHEAD

BASIC TYPE

LE 201 0A

VARIANTS

NONE

TRAILER FIRST-APT

CLASS 370

TF

LH 101

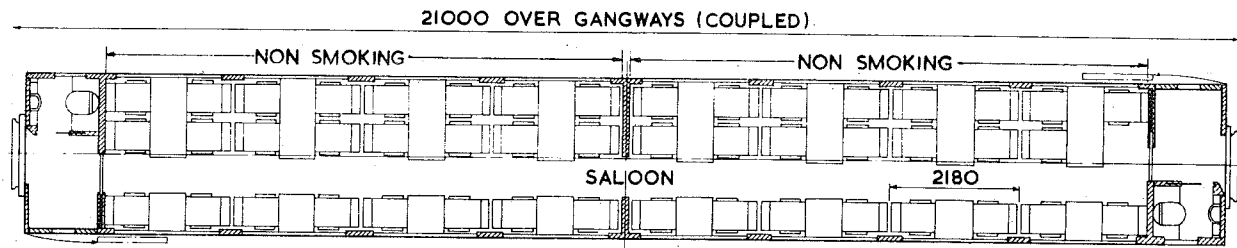
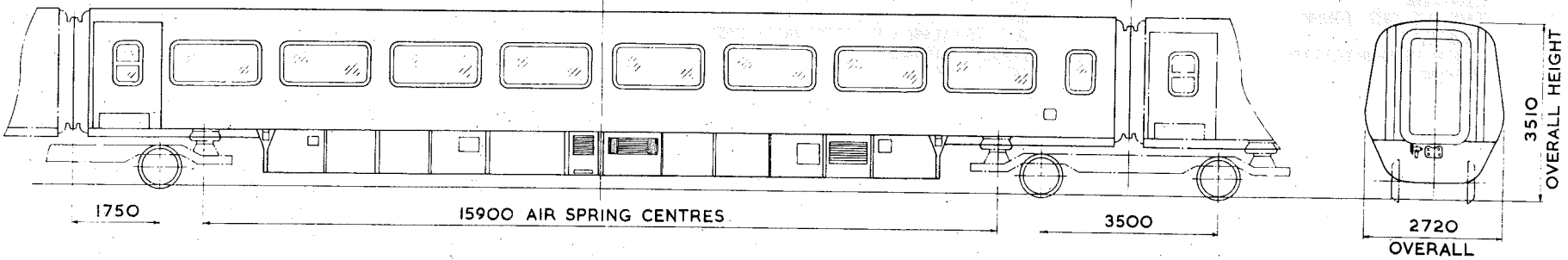

- SEATS 47
- TOILETS 2
- COMPARTMENTS -
- GUARDS COMPARTMENTS -
- VENTILATION FULL AIR CONDITIONING
- CATERING EQUIPMENT -

ORIGINAL DIAGRAMS FOR REFERENCE, - BR 931

ISSUE 2 DATE AUG 81

LH 101

BRAKES
BOGIE/SUSPENSION
BODY CONSTRUCTION
COUPLINGS
TRAIN HEATING
MAX. SPEED M.P.H.
MIN. RAD. CURVE CHAINS
LIGHTING
TARE WEIGHT TONNES
GANGWAYS
TRAIN COMMUNICATION
BUFFERS

BASIC TYPE

ELECTRONIC CONTROL (APT)
BT11 (ARTICULATED)
ALUMINIUM
BAR
ELECTRIC (BR) FULL AIR CONDITIONING
125
4.5
FLUORESCENT & TUNGSTEN
24
APT TRAILER CAR TYPE-BOTH ENDS
PUBLIC ADDRESS
NOT FITTED

ALTERNATIVES

TRACTION DATA FOR MULTIPLE UNITS

APT PROTOTYPE INTRODUCED 1980.
VOLTAGE 25 KV A.C.OVERHEAD

BASIC TYPE

LH 101 0A

VARIANTS

NONE

TRAILER SECOND-APT

CLASS 370

TS

LH 201

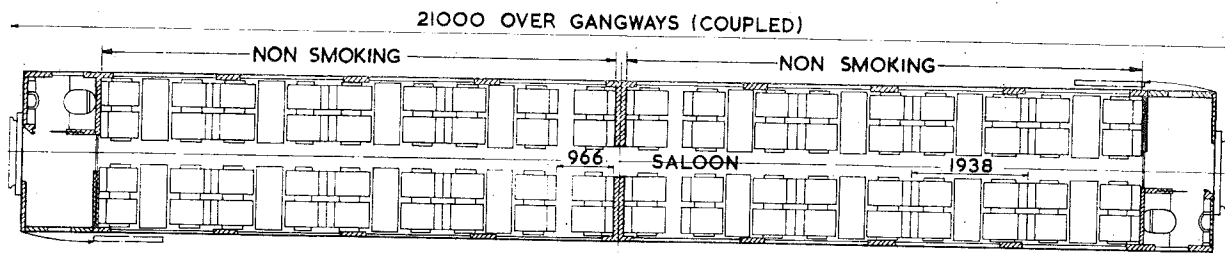
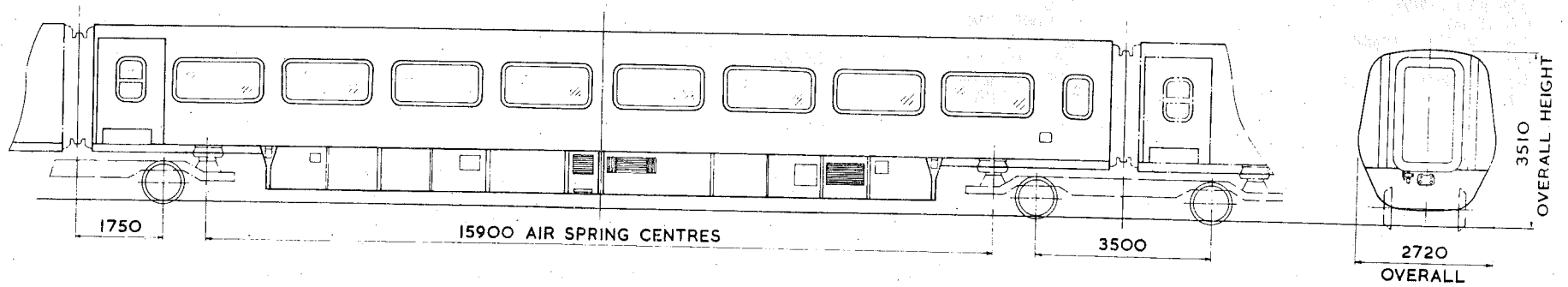

- SEATS 72
- TOILETS 2
- COMPARTMENTS -
- GUARDS COMPARTMENTS -
- VENTILATION FULL AIR CONDITIONING
- CATERING EQUIPMENT -

ORIGINAL DIAGRAMS FOR REFERENCE, -
BR 950

ISSUE 2 DATE AUG 81

LH 201

BASIC TYPE

BRAKES
BOGIE/SUSPENSION
BODY CONSTRUCTION
COUPLINGS
TRAIN HEATING
MAX. SPEED M.P.H.
MIN. RAD. CURVE CHAINS
LIGHTING
TARE WEIGHT TONNES
GANGWAYS
TRAIN COMMUNICATION
BUFFERS

ELECTRONIC CONTROL (APT)
BT11 (ARTICULATED) & BT11a (ARTICULATED) (ONE OF EACH)
ALUMINIUM
BAR
ELECTRIC (BR) FULL AIR CONDITIONING
125
4.5
FLUORESCENT
24
APT TRAILER CAR TYPE-BOTH ENDS
PUBLIC ADDRESS
NOT FITTED

ALTERNATIVES

TRACTION DATA FOR MULTIPLE UNITS

APT PROTOTYPE INTRODUCED 1980.
VOLTAGE 25 KV A.C. OVERHEAD

BASIC TYPE

LH 201 0A

VARIANTS

NONE

TRAILER UNCLASSIFIED-APT

CLASS 370

TU

LH 401

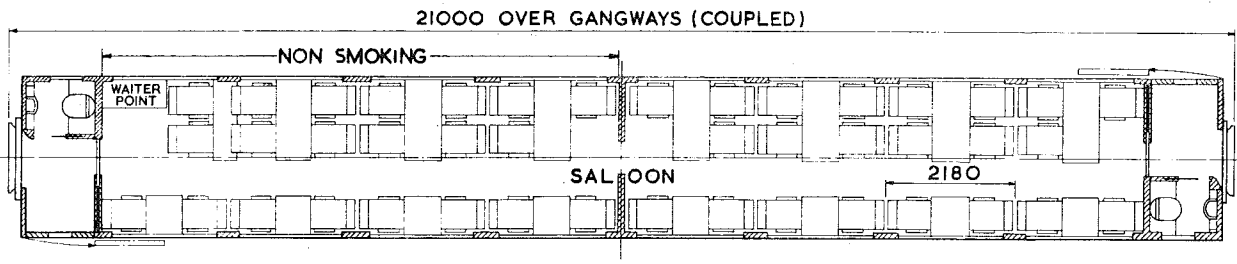
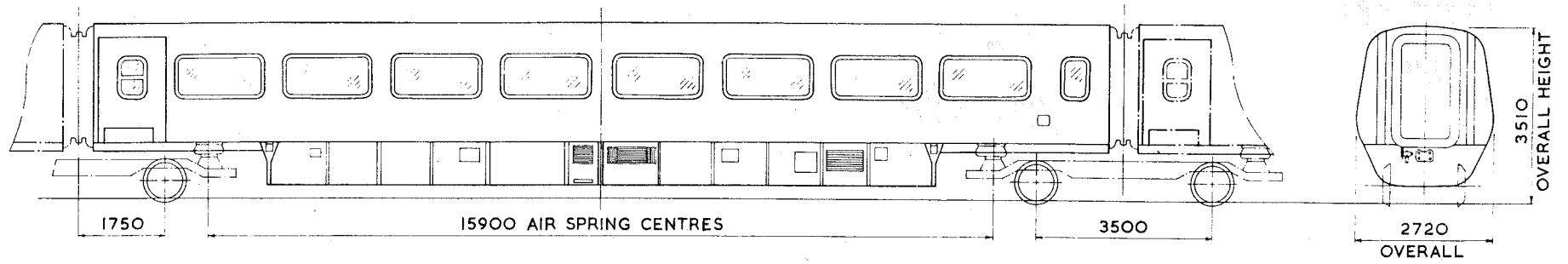

SEATS	43
TOILETS	2
COMPARTMENTS	-
GUARDS COMPARTMENTS	-
VENTILATION	FULL AIR CONDITIONING
CATERING EQUIPMENT	-

ORIGINAL DIAGRAMS FOR REFERENCE.-
BR 960

ISSUE 2 DATE AUG 81

LH 401

BRAKES
BOGIE/SUSPENSION
BODY CONSTRUCTION
COUPLINGS
TRAIN HEATING
MAX. SPEED M.P.H.
MIN. RAD. CURVE CHAINS
LIGHTING
TARE WEIGHT TONNES
GANGWAYS
TRAIN COMMUNICATION
BUFFERS

BASIC TYPE

ELECTRONIC CONTROL (APT)
BT11 (ARTICULATED)
ALUMINIUM
BAR
ELECTRIC (BR) FULL AIR CONDITIONING
125
4.5
FLUORESCENT
24
APT TRAILER CAR TYPE-BOTH ENDS
PUBLIC ADDRESS
NOT FITTED

ALTERNATIVES

TRACTION DATA FOR MULTIPLE UNITS

APT PROTOTYPE INTRODUCED 1980.
VOLTAGE 25 KV A.C. OVERHEAD

BASIC TYPE

LH 401 OA

VARIANTS

NONE

TRAILER BRAKE FIRST-APT

CLASS 370

TBF

LJ 101

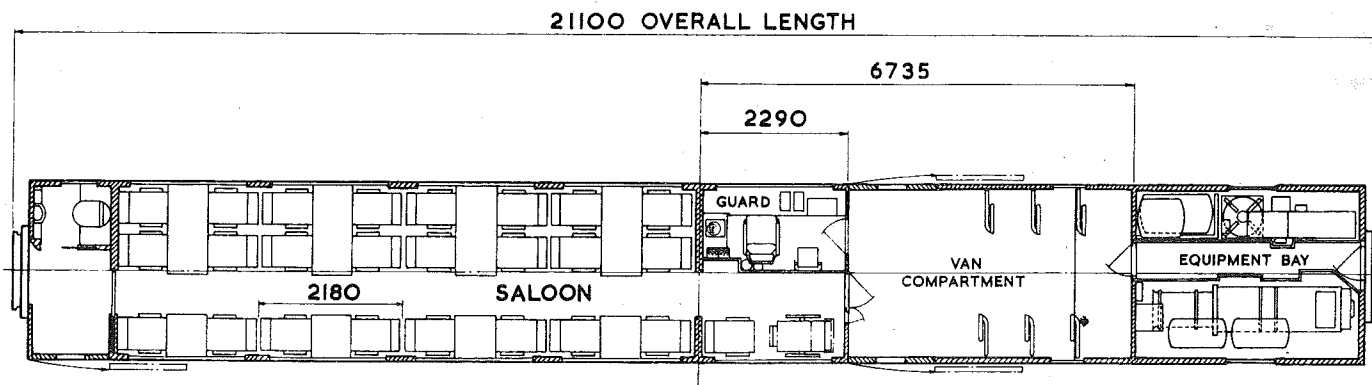
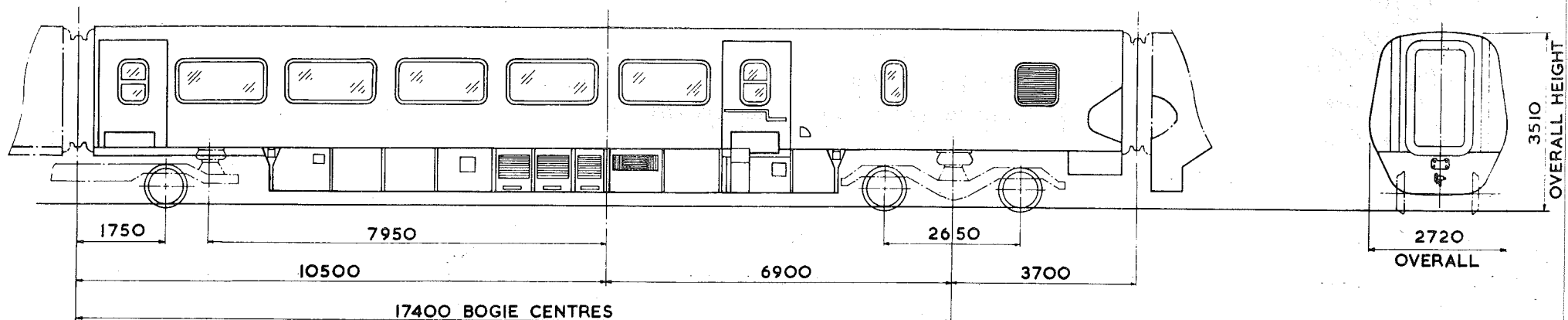

- SEATS 25 PLUS 1 INVALID
- TOILETS 1
- COMPARTMENTS 1
- GUARDS COMPARTMENTS 1
- VENTILATION FULL AIR CONDITIONING
- CATERING EQUIPMENT 1

ORIGINAL DIAGRAMS FOR REFERENCE - BR 911

ISSUE 2 DATE AUG 81

LJ 101

BRAKES
BOGIE/SUSPENSION
BODY CONSTRUCTION
COUPLINGS
TRAIN HEATING
MAX. SPEED M.P.H.
MIN. RAD. CURVE CHAINS
LIGHTING
TARE WEIGHT TONNES
GANGWAYS
TRAIN COMMUNICATION
BUFFERS

BASIC TYPE

ELECTRONIC CONTROL (APT)
BT11 (ARTICULATED) & BT12a (ONE OF EACH)
ALUMINIUM
BAR
ELECTRIC (BR) FULL AIR CONDITIONING
125
4.5
FLUORESCENT & TUNGSTEN
33
APT POWER CAR TYPE ONE END-TRAILER CAR TYPE OTHER END
DRIVER/GUARD & PUBLIC ADDRESS WITH TRANSMITTER
NOT FITTED

ALTERNATIVES

TRACTION DATA FOR MULTIPLE UNITS

APT PROTOTYPE INTRODUCED 1980.
VOLTAGE 25 KV A.C. OVERHEAD

BASIC TYPE

LJ 101 0A

VARIANTS

NONE

TRAILER RESTAURANT SECOND WITH BUFFET-APT

CLASS 370

TRSB

LK 201

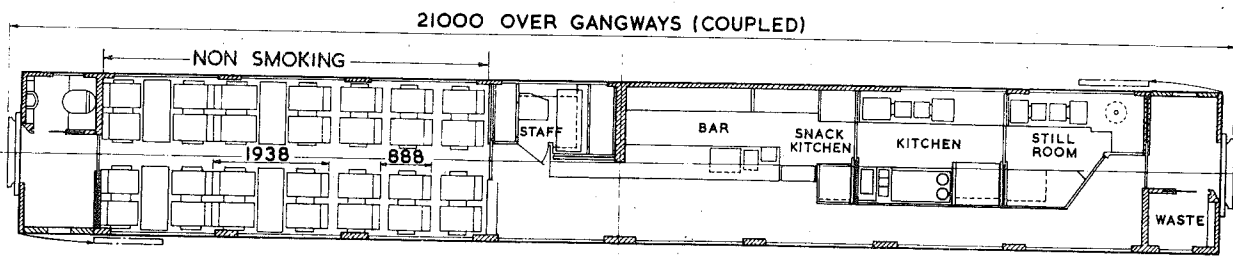
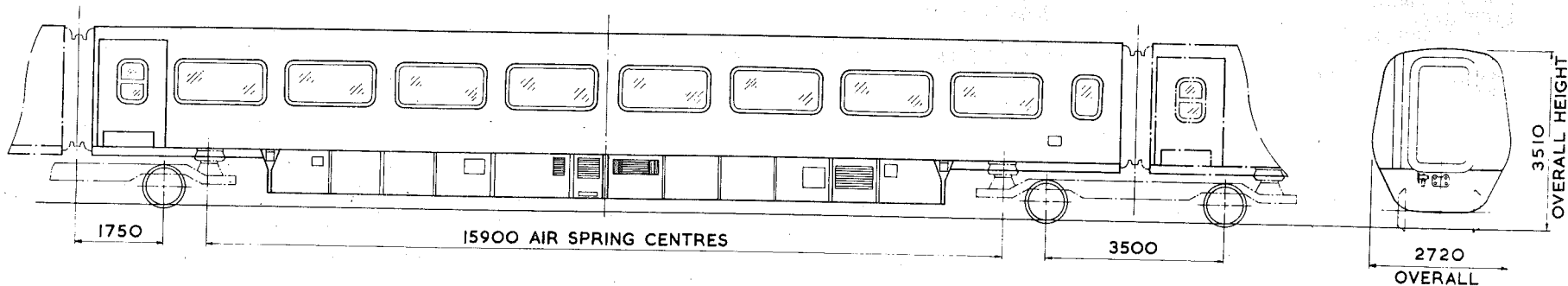

- | | |
|---------------------|------------------------------|
| SEATS | 28 |
| TOILETS | 1 |
| COMPARTMENTS | - |
| GUARDS COMPARTMENTS | - |
| VENTILATION | FULL AIR CONDITIONING |
| CATERING EQUIPMENT | ELECTRIC-MICROWAVE/MICROAIRE |

ORIGINAL DIAGRAMS FOR REFERENCE.-
BR 942

ISSUE DATE
2 AUG 81

LK 201

BRAKES
BOGIE/SUSPENSION
BODY CONSTRUCTION
COUPLINGS
TRAIN HEATING
MAX. SPEED M.P.H.
MIN. RAD. CURVE CHAINS
LIGHTING
TARE WEIGHT TONNES
GANGWAYS
TRAIN COMMUNICATION
BUFFERS

BASIC TYPE

ELECTRONIC CONTROL (APT)
BT11
ALUMINIUM
BAR
ELECTRIC (BR) FULL AIR CONDITIONING
125
4.5
FLUORESCENT
24
APT TRAILER CAR TYPE-BOTH ENDS
PUBLIC ADDRESS
NOT FITTED

ALTERNATIVES

TRACTION DATA FOR MULTIPLE UNITS

APT PROTOTYPE INTRODUCED 1980.

BASIC TYPE

LK 201 0A

VARIANTS

NONE

VEHICLE DIAGRAM BOOK

NO. 210

FOR ELECTRICAL MULTIPLE UNITS

REVISION LETTER NO. 16

<u>LOCATION</u>	<u>ACTION</u>	<u>REASON FOR CHANGE</u>
Diagrams EB 267, 280, EE 216, 271, EF 211, EH 307, and 308	Replace with latest issue of these diagrams.	Diagrams up-dated
In alpha/numerical order	Insert new diagrams EB 281, EC 210, ED 219, 265, EE 160, 236, 237, 273, 274, 308, EH 232, 235, EH 288 and 289	First issue
Diagrams EB 268 EC 208, EE 217, 231, 262, 263, 265, 270 and EH 233.	Remove and destroy these diagrams	No longer required

After incorporating the above, endorse the "Revision Record" at the front of the manual accordingly.

When this Revision Letter has been actioned, it is to be stored at the back of the publication (capacity permitting), for easy future reference.

DATE: JANUARY 1989

REF : 171-125-2

Issue by:-

D of M & EE, BRB
Railway Technical Centre
Derby

VEHICLE DIAGRAM BOOK
NO. 210
FOR ELECTRIC MULTIPLE UNIT
REVISION LETTER NO. 15

<u>LOCATION</u>	<u>ACTION</u>	<u>REASON FOR CHANGE</u>
Index of EMU Vehicle Numbers to Design Code, pages 1 to 33	Remove and destroy	Out of date For up-to-date information contact Rolling Stock Library, Trent House, RTC.
Diagrams EA 207,) EC 203, 206, EE 209,) EF 208, EH 217, 222,) and 223)	Replace with) latest issue of) these diagrams)	Diagrams up-dated
In alpha/numerical order	Insert new diagrams EC 209, EE 233, 234, EH 234, 290, and EP 202	First issue

After incorporating the above, endorse the "Revision Record" at the front of the manual accordingly.

When this Revision letter has been actioned, it is to be stored at the back of the publication (capacity permitting), for easy future reference.

Date : JUNE 1988

Ref : 171-125-2

Tel : 056-3582

Issued by:-

D of M & EE, BRB
Railway Technical Centre
Derby

2310/9580h/2

VEHICLE DIAGRAM BOOK

NO. 210

FOR ELECTRIC MULTIPLE UNITS

REVISION LETTER NO. 14

LOCATIONACTIONREASON FOR CHANGE

Diagrams EA 207,
EB 207, EC 208,
ED 204, 212, 213,
214, 218, EE 205,
219, 305, 307,
EF 201, 205, 213,
303, EH 209, 210,
217, 222, 223, 302,
307, 309, and EO 202

Replace with latest
issue of these pages

Diagrams up-dated

Diagrams EB 206,
ED 206, 207, 208,
209, EE 213, 302,
303, EF 209, 215,
301, EH 206, 207,
220, 305, 306,
and EM 401

Remove and destroy
these diagrams

No longer *required*

After incorporating the above, endorse the "Revision Record" at the front of the manual accordingly.

When this Revision letter has been actioned, it is to be stored at the back of the publication (capacity permitting), for easy future reference.

Date : September 1987

Ref : 171-125-2

Tel : 056-3582

Issued by:-

D of M & EE, BRB
Railway Technical Centre
Derby

VEHICLE DIAGRAM BOOK

NO.210

FOR ELECTRIC MULTIPLE UNITS

REVISION LETTER NO.13

<u>LOCATION</u>	<u>ACTION</u>	<u>REASON FOR CHANGE</u>
Diagrams EC 205, ED 204, EE 209 and EH 308	Replace with latest issue of these diagrams.	Diagrams up-dated
In alpha/numerical order.	Insert new diagrams EB 207, EC 207, ED 218, EE 227, 228, 229, EF 216 305, EH 227, 228, 229 and 309.	First issue

After incorporating the above, endorse the "Revision Record" at the front of the manual accordingly.

When this Revision letter has been actioned, it is to be stored at the back of the publication (capacity permitting) for easy future reference.

Date : February 1987

Ref : 171-125-2

Tel : 056 3582

Issued by:-

D of M & EE, BRB
Railway Technical Centre
Derby

VEHICLE DIAGRAM BOOK
NO 210
FOR ELECTRIC MULTIPLE UNITS
(INCLUDING APT)
REVISION LETTER NO 12

LOCATION	ACTION	REASON FOR CHANGE
Diagrams EA 261, 262 EB 265 266, 267, 271, 272, 274, 277, ED 207, 215 (re-instated), 260, EE 209, 219, 262, 365, 367, EF 205, EH 263, 281 and EP 101	Replace with latest issue of these Diagrams	Diagrams up-dated
In alpha/numerical order	Insert new Diagrams EE 235 and 368	First Issue
Diagrams EB 273, 275 and ED 202	Remove and destroy these Diagrams	No longer required

After incorporating the above, endorse the "Revision Record" at the front of the manual accordingly.

When this Revision letter has been actioned, it is to be stored at the back of the publication (capacity permitting) for easy future reference.

DATE: JULY 1986

REF: 171-125-2

TEL: 056-3582

Issued by:-

D of M & EE, BRB
Railway Technical Centre
Derby

VEHICLE DIAGRAM BOOK

NO. 210

FOR ELECTRIC MULTIPLE UNITS

(INCLUDING APT)

REVISION LETTER NO. 11

LOCATIONACTIONREASON FOR CHARGE

Diagrams EC 205,
EE 306, EF210
211, 214, EH ~~222~~,
223 and 307.

Replace with latest
issue of these pages.

Diagrams up-dated.

In alpha/numerical
order.

Insert new Diagrams
EC 208, EE231,
232 and EH 233.

First issue.

Diagrams ED 215
EH 262 and 274

Remove and destroy
these Diagrams.

No longer required.

After incorporating the above, endorse the "Revision Record" at the front of the manual accordingly.

When this Revision letter has been actioned, it is to be stored at the back of the publication (capacity permitting) for easy future reference.

DATE: MARCH 1986

REF: 171-125-2

TEL: 056-3582

Issued by:-

D of M & EE, BRB
Railway Technical Centre
Derby

2303/1783s/2

VEHICLE DIAGRAM BOOK
NO.210
FOR ELECTRIC MULTIPLE UNITS
(INCLUDING APT)
REVISION LETTER NO.10

<u>LOCATION</u>	<u>ACTION</u>	<u>REASON FOR CHANGE</u>
Diagrams EA 260, EB 269, 270, ED 215, EE 266,361, 362 and EH 271	Replace with latest issue of these pages	Diagrams up-dated
In numerical order	Insert new Diagrams EC 205, 206, EE 224, 225, 226, EH 224, 225, 226, and 308	First issue

After incorporating the above, endorse the "Revision Record" at the front of the manual accordingly.

When this Revision letter has been actioned, it is to be stored at the back of the publication (capacity permitting) for easy future reference.

DATE: NOVEMBER 1985

REF: 171-125-2

TEL: 056-3582

Issued by:-

D of M & EE, BRB
Railway Technical Centre
Derby

VEHICLE DIAGRAM BOOK
 NO.210
 FOR ELECTRIC MULTIPLE UNITS
 (INCLUDING A.P.T.)
 REVISION LETTER NQ.9

<u>LOCATION</u>	<u>ACTION</u>	<u>REASON FOR CHANGE</u>
Diagrams EA263, 264,))	
EB266, 267, 268,))	
271, 272, 277, 279,))	
280, EE262, 263,)	Replace with latest)	
264, 265, 363, 365,)	issue of these Diagrams)	Diagrams up-dated
367, EH160, 267,))	
268, 275, 284,))	
EJ160, 260, 360))	
and 361))	

After incorporating the above, endorse the "Revision Record" at the front of the manual accordingly.

When this Revision letter has been actioned, it is to be stored at the back of the publication (capacity permitting), for easy future reference.

DATE: MARCH 1985

REF : 171-125-2

TEL : 056-3582

Issued by:-

D of M & EE, BRB
 Railway Technical Centre
 Derby

VEHICLE DIAGRAM BOOK
NO. 210
FOR ELECTRIC MULTIPLE UNITS
(INCLUDING APT)

REVISION LETTER NO. 8

<u>LOCATION</u>	<u>ACTION</u>	<u>REASON FOR CHANGE</u>
Diagrams EB 266, EC 202, ED 204, 207, EE 216, 217 and EH 307	Replace with Issues 4 and 5 of these pages	Diagrams up-dated
In numerical order	Insert new diagram EW 501	First Issue
Diagrams EA 203, EB 202, EE 207, and EH 202	Remove and destroy these diagrams	No longer required

After incorporating the above, endorse the "Revision Record" at the front of the manual accordingly.

When this revision letter has been actioned, it is to be stored at the back of the publication (capacity permitting) for easy future reference.

Date : June 1984

Ref : 171-125-2

Tel : 056 3582

Issued by:-

D of M & EE, BRB
Railway Technical Centre
Derby

VEHICLE DIAGRAM BOOK

NO. 210

FOR ELECTRIC MULTIPLE UNITS

(INCLUDING APT)

REVISION LETTER NO. 7

<u>LOCATION</u>	<u>ACTION</u>	<u>REASON FOR CHANGE</u>
Diagrams EA 260, 263,)))
264, EB 266, 267, 269,)))
271, 272, 273, 277,)))
278, ED 207, 260,)	Replace with latest issue)	Diagrams up-dated
EE 266, 269, 363, 364,)	of these diagrams))
364, EH 160, 267, 268,)))
270, 271, 279, 280,)))
281, 360, EJ 160, 260,)))
361, EN 260, 261, 462)))
and 463)))
Diagrams EC 201,)))
EE 212, EE 261, EE 267,)	Remove and destroy these)	No longer required
EH 272 and EO 201)	diagrams))

After incorporating the above, endorse the "Revision Record" at the front of the manual accordingly.

When this Revision letter has been actioned, it is to be stored at the back of the publication (capacity permitting) for easy future reference.

DATE: February 1984

REF: 171-125-2

TEL: 056-3582

Issued by:-

D of M & EE, BRB
 Railway Technical Centre
 Derby

VEHICLE DIAGRAM BOOK

NO. 210

FOR ELECTRIC MULTIPLE UNITS

(INCLUDING APT)

REVISION LETTER NO. 6

<u>LOCATION</u>	<u>ACTION</u>	<u>REASON FOR CHANGE</u>
Diagrams EA 264,) EB 271, EB 272,) EB 278, ED 204,) ED 205, ED 216,) EE 209, EF 205,) EF 301, EH 279,) EH 281 and EH 302)	Replace with) Issues 2, 3, 4) and 5 of these) pages)	Diagrams up-dated
In numerical order	Insert new diagrams) ED 217, EE 223,) EF 303, EF 304,) EH 285, EP 101,) EP 201 and EX 561)	First issue
Diagrams EE 210, EF 206 and EF 302	Remove and destroy) these diagrams)	No longer required

After incorporating the above, endorse the "Revision Record" at the front of the manual accordingly.

When this Revision letter has been actioned, it is to be stored at the back of the publication (capacity permitting), for easy future reference.

DATE: OCTOBER 1983

REF : 171-125-2

TEL : 056-3582

Issued by:-

D of M & EE, BRB
Railway Technical Centre
Derby

J.P.
9. 11. 83.

VEHICLE DIAGRAM BOOK

NO. 210

FOR ELECTRIC MULTIPLE UNITS

(INCLUDING APT)

REVISION LETTER NO. 5

LOCATION

Diagrams EA 264,
EB 269, EB 270,
EB 271, EE 361,
EE 362, EH 219,
EH 222, EH 282,
EH 284 and EJ 361

In numerical order

ACTION

Replace with Issues
2, 3 and 4 of these
pages

Insert new diagrams
ED 216, EE 219
to EE 222, EF 301,
EF 302 and EH 223

REASON FOR CHANGE

Diagrams up-dated

First issue

After incorporating the above, endorse the "Revision Record" at the front of the manual accordingly.

When this Revision letter has been actioned, it is to be stored at the back of the publication (capacity permitting), for easy future reference.

Date: JUNE 1983

Ref : SSS 171-125-2

Tel : 056-3582

Issued by:

D of M & EE, BRB
Railway Technical Centre
Derby

VEHICLE DIAGRAM BOOK

NO 210

FOR ELECTRIC MULTIPLE UNITS

(INCLUDING A.P.T.)

REVISION LETTER NO 4

<u>LOCATION</u>	<u>ACTION</u>	<u>REASON FOR CHANGE</u>
Diagrams EB 271) Replace with Issues 2,)
EB 272, EC 203,) 3 and 4 of these) Diagrams
EE 283, 363, 364) pages (except EB 284) up-dated
EB 221, 281, 284) which is a new issue))
and EJ 361))

After incorporating the above, endorse the "Revision Record" at the front of the manual accordingly.

When this Revision letter has been actioned, it is to be stored at the back of the publication (capacity permitting), for easy future reference.

DATE: FEBRUARY 1983

REF: SSS 171-125-2

TEL: 056-3582

Issued by:
D of M & EE BRB
Railway Technical Centre
Derby

VEHICLES DIAGRAM BOOK

NO 210

FOR ELECTRIC MULTIPLE UNITS

(INCLUDING A.P.T.)

REVISION LETTER NO 3

<u>Location</u>	<u>Action</u>	<u>Reason for Change</u>
Preface page	Replace with new issue dated July 1982	Preface page up-dated
Diagrams EA201, 204, 206, 207, 261, 262, EB 278, 280, EC201, 202, 203, 204, ED204, 207, EE216, 217, 218, EH205, 210, 211, 216 to 219, 221, 307, EI201, 202, 203 and EJ 361	Replace with Issues 2, 3 and 4 of these pages (except Diagrams EC203, EE218 and EH221 which are new issue	Diagrams up-dated
Diagrams EA203, EJ201 and EE211	Remove and destroy these diagrams	No longer required

OLD DIAGRAMS
RETAINED.

After incorporating the above, endorse the "Revision Record" at the front of the manual accordingly.

When this Revision letter has been actioned, it is to be stored at the back of the publication (capacity permitting) for easy future reference.

Date: OCTOBER 1982

Issued by:

Ref: SSS171-125-2

D of M & EE, BRB
Railway Technical Centre
Derby

Tel: 056-3582