

Declarations of
CANDIDACY
Including Statements of Qualifications of
CANDIDATES
•
PROPOSITIONS
together with
ARGUMENTS
and
STATEMENTS OF CONTROLLER
Relating to Costs
to be voted on at
GENERAL MUNICIPAL ELECTION
to be held
NOVEMBER 7, 1961



Attest

Chas. A. Rogers

Registrar of Voters

Published under provisions of Sections 176 and 183 of the
Charter of the City and County of San Francisco.

SPECIAL NOTE:

In order to avoid congestion and possible delay at the polls on election day voters are urged to:

1. Use the polling place card enclosed herewith. Mark your choices for the various offices and propositions. **TAKE THE CARD WITH YOU TO THE POLLS** and you can complete your voting in less than **ONE MINUTE**.

2. Vote early, if possible.

Chas. A. Rogers
Registrar of Voters.

Permanent registration is maintained by **VOTING**.

INDEX OF CANDIDATES

| | Page | | Page |
|----------------------------|------|--------------------------------|------|
| John Abraham | 3 | Alan H. Nichols | 21 |
| Albert A. Axelrod | 41 | L. Patrick (Pat) O'Brien | 22 |
| William C. Blake | 4 | William A. O'Brien | 42 |
| Roger Boas | 5 | Thomas M. O'Connor | 36 |
| Archie Brown | 6 | Thomas P. O'Toole | 23 |
| Donald J. Bruce | 7 | Hayden Perry | 24 |
| Jim Coventry | 8 | Al J. Quinn | 25 |
| Thomas P. Curtin | 9 | Jose Julio Sarria | 26 |
| Andrew J. Eyman | 43 | Leon H. Sorell | 39 |
| A. F. (Gus) Gaynor..... | 10 | Donald J. Sullivan | 27 |
| John J. Goodwin | 38 | J. Joseph Sullivan | 37 |
| Edwin J. Greenough | 11 | John L. Sullivan | 28 |
| Warren Hinckle | 12 | Warren Sullivan | 29 |
| George W. Johns..... | 13 | Peter Tamaras | 30 |
| W. Harry Johns..... | 14 | Joseph E. Tinney | 31 |
| Robert O. Jones..... | 15 | Harold Treskunoff | 32 |
| W. H. (Bill) Lammers..... | 16 | Lenore D. Underwood | 40 |
| Ernest Lotti | 17 | Robert Vanderbilt | 33 |
| Charles Marsalli | 18 | Charles D. Walker | 34 |
| Joseph John Migliozi | 19 | Dina Franchi Zickel | 35 |
| Jack Morrison | 20 | | |

INDEX OF PROPOSITIONS

| PROPOSITION | | Page |
|-------------|---|------|
| A | \$115,000,000 Municipal Water System Bonds, 1961..... | 47 |
| B | \$1,100,000 Fort Funston Bonds, 1961..... | 52 |
| C | \$3,282,000 Public Welfare Bonds, 1961..... | 54 |
| D | Charter Amendment relating to appointment of Chief Administrative Officer..... | 56 |
| E | Charter Amendment relating to Library Commission.... | 57 |
| F | Charter Amendment relating to Health Service System.. | 59 |
| G | Charter Amendment relating to replacement or repair of property damaged in line of duty..... | 62 |
| H | Charter Amendment relating to suspension and dismissal for cause..... | 63 |
| I | Declaration of Policy—relating to acquisition of Fox Theatre property..... | 69 |
| A-B-C | Ordinance calling Special Bond Election..... | 44 |

For Supervisor

JOHN ABRAHAM

I hereby declare myself a candidate for the office of Supervisor for the City and County of San Francisco, State of California, to be voted for at the General Municipal Election to be held in the said City and County on November 7, 1961, and declare the following to be true:

That I shall have been a resident of the City and County of San Francisco for a period of at least five years and an elector thereof for a period of at least one year immediately prior to the time for taking such office: That my name is John Abraham. My residence address is at No. 2980-26th Avenue, San Francisco. My business or occupation is Painting Contractor.

My qualifications for said office are as follows: As a successful business man and veteran of World War II, I know the importance of ACTION in running a business, a war or a CITY. I call for immediate action on a vehicle safety inspection code to save human lives from the wanton slaughter of runaway trucks and cars. I urge immediate action on freeways to save San Francisco homes from needless destruction. Make this a ballot issue! While I favor thorough investigation and efficient planning, I will also work vigorously for decisive ACTION on all issues to insure present and future progress for our city.

Pursuant to the provisions of Section 175 of Charter of said City and County, I desire that the following designation "Painting Contractor" be placed immediately under my name as it will appear on all ballots at the General Municipal Election to be held November 7, 1961.

Signature of Candidate: JOHN ABRAHAM.

Subscribed before me and filed this 19th day of September, 1961.

CHAS. A. ROGERS,
Registrar of Voters.
By P. LEMONE,
Deputy Registrar of Voters.

The sponsors for John Abraham are:

Alma Abraham, 2980 - 26th Ave.; Housewife.
Art Benjamin, 582 - 4th Ave.; Bus. Agent Sailor's Union of the Pacific.
Fredric H. Busher, 1922 Funston Ave.; Minister Methodist Church.
Anna Demetroff, 370 Parnassus Ave.; Owner of a Rest Home.
Henry L. Cuniberti, M.D., 6200 Geary St.; Physician-Surgeon.
F. D. Haynes, 1832 - 16th Ave.; Clergyman.
Al Hicks, 770 Page St.; Labor Relations—U. S. Steel Corporation.
Leo A. Isaef, 1490 - 16th Ave.; Insurance Broker.
Raymond Lawless, 3820 Lawton St.; Partner & Advertising Manager Sunset News.
Chang W. Lee, 1512 Jones St.; Dentist.
J. Webster McDougall, 1627 - 16th Ave.; Editor and Publisher.
Clara K. McLinden, 2329 - 32nd Ave.; Owner of The Fire Falls Restaurant.
Matthew J. Mirabella, 325 Warren Dr.; Grocer.
Leone Webb O'Rourke, 1679 - 29th Ave.; Real Estate Broker.
Michael Perri, 159 Lakeshore Dr.; Real Estate—Insurance.
Maurice Perstein, 108 Villa Terrace; Flag Manufacturer.
Angelo Rolando, 3276 Harrison St.; Real Estate Broker.
Frank Spadarella, 2960 - 21st Ave.; Owner Toto's Restaurant.
Dermott J. Sullivan, 1547 - 21st Ave.; Funeral Director.
Anne Varakin, 124 Ninth Ave.; Attorney.

For Supervisor
WILLIAM C. BLAKE

I hereby declare myself a candidate for the office of Supervisor for the City and County of San Francisco, State of California, to be voted for at the General Municipal Election to be held in the said City and County on November 7, 1961, and declare the following to be true:

That I shall have been a resident of the City and County of San Francisco for a period of at least five years and an elector thereof for a period of at least one year immediately prior to the time for taking such office: That my name is William C. Blake. My residence address is at No. 264 Mallorca Way, San Francisco. My business or occupation is Shiprepair.

My qualifications for said office are as follows: Born in San Francisco 41 years ago; attended local schools; married, father of two children; owner-operator, local ship repair firm; Commander, U. S. Naval Reserve, with five years' World War II overseas duty; member, Bay Area Air Pollution Control District. As Supervisor for past seven years, and chairman of Supervisors' Streets and Highways Committee, have vigorously opposed unwarranted encroachment of freeways upon rightful interests of residents, property owners and business concerns. Firmly pledged to continue sponsorship of adequate housing, standards of existence and transit fare concessions for elderly; solution of traffic and local-regional transit problems; sensible guidance for youth; equality of treatment for all; and governmental economy without loss of essential services.

Pursuant to the provisions of Section 175 of Charter of said City and County, I desire that the following designation "Incumbent" be placed immediately under my name as it will appear on all ballots at the General Municipal Election to be held November 7, 1961.

Signature of Candidate: WILLIAM C. BLAKE.

Subscribed before me and filed this 14th day of September, 1961.

CHAS. A. ROGERS,
Registrar of Voters.
By KENNETH J. LONG,
Deputy Registrar of Voters.

The sponsors for William C. Blake are:

Mrs. William C. Blake, 264 Mallorca Way; Homemaker.
Dr. Peter T. Angel, 1867 - 15th Ave.; Retired Dentist.
Mrs. Byron Arnold, 2930 - 21st Ave.; Housewife.
Harold A. Berliner, 10 Crown Terrace; Manufacturer.
Roy N. Buell, 2512 Pacific Ave.; Executive.
William Jack Chow, 550 Montgomery St.; Attorney-at-Law.
John A. Ertola, 219 - 32nd Ave.; Lawyer.
Thomas E. Feeney, 126 Miraloma Dr.; Attorney.
John P. Figone, Jr., 1046 Union St.; Travel Agent.
Robert J. Grassilli, 778 Girard St.; Real Estate Broker.
J. R. Klawans, 27 Avila St.; Attorney.
Louis T. Kruger, 23 Miguel St.; Attorney-at-Law.
Cyril Magnin, 950 Mason St.; Merchant.
William M. Malone, 1 Gabilan Way; Attorney-at-Law.
Chris D. McKeon, 405 St. Francis Blvd.; Builder.
John D. Monaghan, 31 Grand View Ave.; Caterer.
Mrs. Samuel R. Sherman, 1800 Pacific Ave.; Housewife.
Max Sobel, 2127 Broadway; Wholesaler.
John H. Swanson, 3140 Mission St.; Bowling Alley Owner.
Joseph C. Tarantino, 2427 Bay St.; Merchant.

For Supervisor
ROGER BOAS

I hereby declare myself a candidate for the office of Supervisor for the City and County of San Francisco, State of California, to be voted for at the General Municipal Election to be held in the said City and County on November 7, 1961, and declare the following to be true:

That I shall have been a resident of the City and County of San Francisco for a period of at least five years and an elector thereof for a period of at least one year immediately prior to the time for taking such office: That my name is Roger Boas. My residence address is at No. 3329 Washington Street, San Francisco. My business or occupation is Businessman.

My qualifications for said office are as follows: Born and raised in San Francisco, I went to public schools here and graduated from Stanford University. I served in the U. S. Army in World War II and was awarded the Silver Star and the Bronze Star. Since 1945, I have operated my own business. I am married and have two sons. As moderator of Profile: Bay Area, I originated the first television program dealing with controversial local questions. I am active in organizations to improve housing, education and city planning and to combat juvenile delinquency and racial discrimination. If elected, I will work for constructive new policies in those fields.

Pursuant to the provisions of Section 175 of Charter of said City and County, I desire that the following designation "Businessman" be placed immediately under my name as it will appear on all ballots at the General Municipal Election to be held November 7, 1961.

Signature of Candidate: ROGER BOAS.

Subscribed before me and filed this 13th day of September, 1961.

CHAS. A. ROGERS,
Registrar of Voters.

The sponsors for Roger Boas are:

Nancy Boas, 3329 Washington St.; Housewife.
John P. Andersen, 1122 Florida St.; Business Representative.
Jefferson A. Beaver, 616 Los Palms Drive; Executive.
Joe Beeman, 758 - 40th Ave.; President, San Francisco Young Democrats.
Mrs. Harold A. Berliner, 10 Crown Terrace; Housewife.
Willie L. Brown Jr., 949 Broderick St.; Attorney at Law.
William K. Coblentz, 10 Fifth Ave.; Attorney.
Jesse C. Colman, 1275 Greenwich St.; Director Citizens Federal Savings & Loan Assn.
Armond De Martini, 110 - 32nd Ave.; Educator.
John A. Ertola, 219 - 32nd Ave.; Lawyer.
William D. Kilduff, 3333 Jackson St.; Investment Broker.
Harold Lopez, 1801 Wawona St.; Sec. & Bus. Mgr. Teamsters Union Local 85.
Mrs. Thomas C. Lynch, 98 Clarendon Blvd.; Housewife.
William M. Malone, 1 Gabilan Way; Attorney at Law.
Joseph P. Mazzola, 127 Lakeshore Drive;
Business Manager of Plumbers & Steamfitters Local 38.
Leo T. McCarthy, 1932 Jefferson St.; Administrative Assistant.
E. O. Midyett, 410 Pierce St.;
Member Advisory Committee National Council Senior Citizens.
Bogoslav I. Radetich, 782 Kansas St.; Bakery Owner.
Yoritada Wada, 565 - 4th Ave.; Social Worker.
Zeppelin W. Wong, 923 Vallejo St.; Attorney at Law.

For Supervisor
ARCHIE BROWN

I hereby declare myself a candidate for the office of Supervisor for the City and County of San Francisco, State of California, to be voted for at the General Municipal Election to be held in the said City and County on November 7, 1961, and declare the following to be true:

That I shall have been a resident of the City and County of San Francisco for a period of at least five years and an elector thereof for a period of at least one year immediately prior to the time for taking such office: That my name is Archie Brown. My residence address is at No. 1027 Brussels Street, San Francisco. My business or occupation is Longshoreman.

My qualifications for said office are as follows: Twenty-five years as a Longshoreman and active trade unionist, participating in the people's struggles for a better life. I am a PEACE candidate. An independent-labor nominee with socialist convictions, I advocate trade with China, JOBS for youth and minorities to prevent delinquency, public housing in redevelopment areas, an end to ALL discrimination, city training for electronics and automation, more class rooms and teachers, nullification of the Blyth-Zellerbach schemes. My platform was drafted by representatives of youth, the Negro people, senior citizens, union men and women. World War II veteran, father of four.

Pursuant to the provisions of Section 175 of Charter of said City and County, I desire that the following designation "Longshoreman" be placed immediately under my name as it will appear on all ballots at the General Municipal Election to be held November 7, 1961.

Signature of Candidate: ARCHIE BROWN.

Subscribed before me and filed this 13th day of September, 1961.

CHAS. A. ROGERS,
Registrar of Voters.
By HAROLD J. O'DONNELL,
Deputy Registrar of Voters.

The sponsors for Archie Brown are:

Daniel Basarich, 44 - 3rd St.; Retired Longshoreman.
Joseph Figueiredo, 1250 Girard St.; Warehouseman.
J. Hommes, 445 Octavia St.; Stevedore (Retired).
Ralph Izard, 1335-A Columbus Ave.; writer, lecturer, translator.
Nils Lannge, 472 - 7th Ave.; Longshoreman.
Richard Lynden, 557 Duncan St.; Union Official.
Grace Partridge, 411 Pierce St., Apt. 1; Clerk.
George D. Pickering, 3518 Sacramento St.; Retired Longshoreman.
Elmer C. Richardson, 1768 Hayes St.; Retired Longshoreman.
Frederick D. Smith, 85 Henry St.; Attorney at Law.
Herman Stuyvelaar, 621 - 27th St.; Retired Ships' Clerk.
G. Woolf, 520 Frederick St.; I.L.W.U. Pensioner.
Karl G. Yoneda, 320 Pennsylvania St.; Longshoreman.

For Supervisor
DONALD J. BRUCE

I hereby declare myself a candidate for the office of Supervisor for the City and County of San Francisco, State of California, to be voted for at the General Municipal Election to be held in the said City and County on November 7, 1961, and declare the following to be true:

That I shall have been a resident of the City and County of San Francisco for a period of at least five years and an elector thereof for a period of at least one year immediately prior to the time for taking such office: That my name is Donald J. Bruce. My residence address is at No. 1329-16th Avenue, San Francisco. My business or occupation is Public Relations.

My qualifications for said office are as follows: Born and reared in San Francisco, Married—Property Owner—ex-Printer and Hotel Owner. Elected many times on County Committees. Received 94,284 votes for Secretary of State—History Clerk in the Legislature. Helped the Road and Street Bill getting many millions of dollars for San Francisco, for Street Repairs and Water-power. I love public life and intend when elected to give my full time to the duties of Supervisor. For Water Bonds. Always for the welfare of the entire Community. No More Freeways. I gratefully acknowledge and respectfully ask for your Support.

Pursuant to the provisions of Section 175 of Charter of said City and County, I desire that the following designation "Public Relations" be placed immediately under my name as it will appear on all ballots at the General Municipal Election to be held November 7, 1961.

Signature of Candidate: DONALD J. BRUCE.

Subscribed before me and filed this 8th day of September, 1961.

CHAS. A. ROGERS,
Registrar of Voters.
By P. LEMONE,
Deputy Registrar of Voters.

The sponsors for Donald J. Bruce are:

Timothy I. Fitzpatrick, 2677 Larkin St.; Judge of Superior Court.
Mrs. Donald J. Bruce, 1329 - 16th Ave.; Housewife.
George Brarens, 1415 - 39th Ave.; S.F.F.D. Retired.
James Cunnie, 127 Ellis St.; Retired.
Robert F. Domergue, 465 - 15th Ave.; Hotel Owner.
Frederick T. Emmons, 2363 - 16th Ave.; Builder.
James A. Himmel, 174 Ellis St.; Attorney at Law.
Sidney A. Hammerslough, 919 Sutter St.; Ticket Agent—The Gray Line Inc.
Louis T. Kruger, 23 Miguel St.; Attorney at Law.
Alessio Morini, 1272 Market St.; Public Welfare.
Mrs. Grace D. Shea, 328 Virginia Ave.; Housewife.
Herbert H. Smith, 616 - 26th Ave.; Police Officer (Retired).

For Supervisor
JIM COVENTRY

I hereby declare myself a candidate for the office of Supervisor for the City and County of San Francisco, State of California, to be voted for at the General Municipal Election to be held in the said City and County on November 7, 1961, and declare the following to be true:

That I shall have been a resident of the City and County of San Francisco for a period of at least five years and an elector thereof for a period of at least one year immediately prior to the time for taking such office: That my name is Jim Coventry. My residence address is at No. 123-26th Avenue, San Francisco. My business or occupation is Legal Investigator.

My qualifications for said office are as follows: As an Air Force Veteran, businessman, property owner and family man, I pledge my sincere efforts to a full program of advancement for our City; to improve the educational system, to reduce the problem of wayward children; to insure the Presidio lands are not desecrated by ugly housing projects, to represent all the people who live and take pride in our City, to plan for and implement an effective transit system which will be practical, economical and serve the needs of all the citizens without destroying the historic beauty of our City or the rights of property owners.

Pursuant to the provisions of Section 175 of Charter of said City and County, I desire that the following designation "Legal Investigator" be placed immediately under my name as it will appear on all ballots at the General Municipal Election to be held November 7, 1961.

Signature of Candidate: JIM COVENTRY.

Subscribed before me and filed this 8th day of September, 1961.

CHAS. A. ROGERS,
Registrar of Voters.
By KENNETH J. LONG,
Deputy Registrar of Voters.

The sponsors for Jim Coventry are:

Diane E. Coventry, 123 - 26th Ave.; Housewife.
Tom Spinosa, 215 Banks St.; Pres. Cavalier Records, Inc.—Arrow Press.
Rudolph Schaeffer, 2255 Mariposa St.; Director Rudolph Schaeffer School of Design.
Nathan Cohn, 510 Castenada Ave.; Attorney at Law.
Floyd Buick, 1948 Powell St.; Radio Commentator.
Catherine Anne Haney, 235 Grandview Ave.; Pediatrician.
Percy P. Poliak, 2832 Union St.; Physician.
Paul D. Hardman, 1782 Pacific Ave.; Banker.
Arthur B. Chinn, 738 Washington St.; Public Accountant.
Frederick Reel Jr., 730 Bay St.; Insurance Broker.
John T. Phillips, 119 - 26th Ave.; Physician.
Robert D. Barbagelata, 201 El Camino Del Mar; Attorney at Law.
Leon Carlen, 693 University St.; Gen. Bldg. Contractor.
Harry O. Fairbairn, 5200 Anza St.; Insurance Broker.
Jack H. Dwyer, 1714 - 32nd Ave.; Insurance Broker.
Herbert I. Ross, 3511 Clay St.; Insurance Broker.

For Supervisor
THOMAS P. CURTIN

I hereby declare myself a candidate for the office of Supervisor for the City and County of San Francisco, State of California, to be voted for at the General Municipal Election to be held in the said City and County on November 7, 1961, and declare the following to be true:

That I shall have been a resident of the City and County of San Francisco for a period of at least five years and an elector thereof for a period of at least one year immediately prior to the time for taking such office: That my name is Thomas P. Curtin. My residence address is at No. 2925 Larkin Street, San Francisco. My business or occupation is Drayman.

My qualifications for said office are as follows: Born South of Market, March 17, 1916, am married and have three children. Educated in Public Schools, and University of San Francisco. Past President of Fraternal Order of Eagles. Member of Benevolent Order of Elks. Vice President of San Francisco Community Council for Youth. President of Co. I, San Francisco Police Reserve. Owner of Curtin Drayage & Warehouse Company. Platform: Stop tax bite on property owners; Better planned freeways—no tax property removed from tax structure; Relieve traffic congestion in downtown areas; A just urban redevelopment; Parking relief for neighborhood merchants.

Pursuant to the provisions of Section 175 of Charter of said City and County, I desire that the following designation "Drayman" be placed immediately under my name as it will appear on all ballots at the General Municipal Election to be held November 7, 1961.

Signature of Candidate: THOMAS P. CURTIN.

Subscribed before me and filed this 11th day of September, 1961.

CHAS. A. ROGERS,
Registrar of Voters.
By P. LEMONE,
Deputy Registrar of Voters.

The sponsors for Thomas P. Curtin are:

Joseph J. Bartelme, 61 Lakewood Ave.; Sales Manager.
Walter F. Calcagno, 3123 Franklin St.; Attorney.
Ann E. Gane, 559 - 14th Ave.; Housewife.
Robert M. Gane, 559 - 14th Ave.; Certified Public Accountant.
Robert J. Gemignani, 1817 Stockton St.; Social Worker.
Alfred J. Giannini, 1754 - 21st Ave.; Truck Driver.
Mrs. Helen S. Giannini, 1754 - 21st Ave.; Home-Maker.
Gerald A. Gilson, 2401 - 23rd Ave.; Insurance Agent.
Grace G. Goldberg, 811 - 30th Avenue; Housewife.
Maurice Goldberg, 811 - 30th Avenue; Wholesaler.
Mrs. Marie Parma, 846 No. Point St.; Housewife.
Adolph J. Pellegrini, 1478 - 29th Ave.; Retired.
Angelo Piscia, 1784 Beach St.; Waiter.
Albert Samuels, 1880 Jackson St.; Jeweler.
Edward W. Schaefer, 848 Prague St.; Importers & Exporters.
Dr. Henry A. Tagliaferri, 282 Silver Ave.; Oral Surgeon.
Joseph Warshaw, 542 Lyon St.; Furrier.
C. J. Wellington MD, 2299 Sutter St.; Physician.

For Supervisor
A. F. (GUS) GAYNOR

I hereby declare myself a candidate for the office of Supervisor for the City and County of San Francisco, State of California, to be voted for at the General Municipal Election to be held in the said City and County on November 7, 1961, and declare the following to be true:

That I shall have been a resident of the City and County of San Francisco for a period of at least five years and an elector thereof for a period of at least one year immediately prior to the time for taking such office: That my name is A. F. (Gus) Gaynor. My residence address is at No. 1370-25th Avenue, San Francisco. My business or occupation is Insurance.

My qualifications for said office are as follows: As Supervisor I will advocate: 1. Coordination of emergency and private hospital service to save taxpayers' money and improve emergency service. 2. Revamp pension plans to give more equitable allowance to municipal employees. 3. Study feasibility of providing free public transportation. 4. Review present system of one-way streets. The system is unfair to business people and confusing to residents and visitors. 5. Study downtown traffic control so as to save police manpower. Erect one traffic tower and equip it with television style operation so that four police officers can regulate all downtown traffic in daytime.

Pursuant to the provisions of Section 175 of Charter of said City and County, I desire that the following designation "Insurance" be placed immediately under my name as it will appear on all ballots at the General Municipal Election to be held November 7, 1961.

Signature of Candidate: AUGUSTINE F. GAYNOR.

Subscribed before me and filed this 15th day of September, 1961.

CHAS. A. ROGERS,
Registrar of Voters.
By ALEX McCARTHY,
Deputy Registrar of Voters.

The sponsors for A. F. (Gus) Gaynor are:

Ernesta R. Gaynor, 1370 - 25th Ave.; Clerk.
R. Emmet Allen, 1101 Green St.; Physician.
Thomas P. Brady, 2626 Kirkham St.; Escrow & Title Officer.
Elsie Clennell, 2471 - 35th Ave.; Housewife.
Leslie A. Clennell, 2471 - 35th Ave.; Businessman.
Jos. M. Hannan, 68 Hancock St.; Financial Secty. I. A. of M. #732.
Frank X. Harrigan, 1507 California St.; Salesman.
Cornelius Lynch, 2444 - 14th Ave.; Ship Clerk.
Clarence M. Mihan, 458 Gellert Drive; Executive.
Wm. A. Price, Jr., 331 Pennsylvania Ave.; M. D.
Francis R. Spinelli, 191 Granville Way; Pharmacist.
Helen G. Tait, 2890 California St.; Special Accountant.
Catherine R. Thomson, 50 Rockwood Court; Legal Secretary.

For Supervisor

EDWIN J. GREENOUGH

I hereby declare myself a candidate for the office of Supervisor for the City and County of San Francisco, State of California, to be voted for at the General Municipal Election to be held in the said City and County on November 7, 1961, and declare the following to be true:

That I shall have been a resident of the City and County of San Francisco for a period of at least five years and an elector thereof for a period of at least one year immediately prior to the time for taking such office: That my name is Edwin J. Greenough. My residence address is at No. 275 Castro Street, San Francisco. My business or occupation is Barber—Apartment House Owner.

My qualifications for said office are as follows: I Edwin J. Greenough am a married man, a property owner and have been in business for myself at the same location for 16 years. Since this is my home and being very interested in Civic affairs I promise to do my best for the good of our City.

Pursuant to the provisions of Section 175 of Charter of said City and County, I desire that the following designation "Barber, Apartment Owner" be placed immediately under my name as it will appear on all ballots at the General Municipal Election to be held November 7, 1961.

Signature of Candidate: EDWIN J. GREENOUGH.

Subscribed before me and filed this 18th day of September, 1961.

CHAS. A. ROGERS,
Registrar of Voters.
By HAROLD J. O'DONNELL,
Deputy Registrar of Voters.

The sponsors for Edwin J. Greenough are:

Mrs. Edwin J. Greenough, 275 Castro St.; Beauty Shop Owner.
E. J. Armando, 2510 Taraval St.; Real Estate & Insurance Broker.
Fred A. Barsuglia, 80 Linda St.; Grocery Clerk.
Don R. Francisco, 1250 Jones St.; Realtor.
Robert B. Graydon, 610 Font Blvd.; Insurance Salesman.
Emil H. Heiser, 1500 - 42nd Ave.; Retired.
Leo P. Hubert, 352 - 16th Ave.; Retired.
Mrs. Lilly A. Hubert, 352 - 16th Ave.; Housewife.
Olin J. Loy, 73 Sunview Dr.; Cook.
Mrs. Betty J. Mendiola, 880 Foerster St.; Housewife.
Ted P. Metz, 2435 - 30th Ave.; Retired.
H. J. Nadeau, 1205 - 37th Ave.; Music Operator.
Mrs. Gertrude Reinhart, 745 Sutter St.; Retired.
Chas. H. Rosenthal, 21 Guerrero St.; Office Furniture Salesman.
Kenneth L. Shelley, 44 Forest Knolls Dr.; Teacher.
Charles F. Strothoff, 1855 Market St.; Architect.
Stephen A. Territo, 62 Newburg St.; Salesman.
M. Neil Wallace, 1518 Dolores St.; Service Station Operator.
William M. Wright, 1973 - 20th Ave.; Merchant.

For Supervisor

WARREN HINCKLE

I hereby declare myself a candidate for the office of Supervisor for the City and County of San Francisco, State of California, to be voted for at the General Municipal Election to be held in the said City and County on November 7, 1961, and declare the following to be true:

That I shall have been a resident of the City and County of San Francisco for a period of at least five years and an elector thereof for a period of at least one year immediately prior to the time for taking such office: That my name is Warren Hinckle. My residence address is at No. 2567-14th Avenue, San Francisco. My business or occupation is Partner, Barth, Hughes & Hinckle.

My qualifications for said office are as follows: San Francisco's skyline has changed for the worst in the past decade; our population has declined. We are suffering from a mental attitude which favors parking lots before houses and cars before people. I believe we must safeguard our neighborhoods against ruin by ugly freeways and promote neighborhood beauty; increase—not sell—our park and recreational areas; keep light industry in the City and create more jobs; establish architectural controls to protect our City's traditional beauty; wherever possible promote "natural" redevelopment which will retain our skyline and existing buildings; make plans for comfortable housing at reasonable prices for all San Franciscans.

Pursuant to the provisions of Section 175 of Charter of said City and County, I desire that the following designation "Businessman" be placed immediately under my name as it will appear on all ballots at the General Municipal Election to be held November 7, 1961.

Signature of Candidate: WARREN J. HINCKLE III

Subscribed before me and filed this 13th day of September, 1961.

CHAS. A. ROGERS,
Registrar of Voters.
By P. LEMONE,
Deputy Registrar of Voters.

The sponsors for Warren Hinckle are:

Mrs. W. J. Hinckle, 2567 - 14th Ave.; Housewife.
John D. Bailey, 980 Bush St.; Bartender.
Thomas F. Carter, 37 Miguel St.;
Asst. Development Director—University of S. F.
George P. Comisky, 372 - 17th Ave.; Bookbinder.
Virginia C. Comisky, 372 - 17th Ave.; Housewife.
William L. Denton, 2920 Polk St.; Theatrical Producer.
Agnes B. Gagne, 1450 - 45th Ave.; Secretary.
Phillip Roger Hughes, 587 Los Palms Drive; Partner, public relations firm.
Ann Z. Lewis, 1929 Greenwich St.; Interior Designer.
Reese H. Lewis, 1929 Greenwich St.; Interior Designer.
Kenneth L. Myers, 2571 - 14th Ave.; Acme Export Packing Co.
Regina Myers, 2571 - 14th Ave.; Housewife.
William B. Upton (III), 26 Julius St.; Publisher representative.
Cerise C. Weinberger, 60 Merced Ave.; Housewife.

For Supervisor
GEORGE W. JOHNS

I hereby declare myself a candidate for the office of Supervisor for the City and County of San Francisco, State of California, to be voted for at the General Municipal Election to be held in the said City and County on November 7, 1961, and declare the following to be true:

That I shall have been a resident of the City and County of San Francisco for a period of at least five years and an elector thereof for a period of at least one year immediately prior to the time for taking such office: That my name is George W. Johns. My residence address is at No. 19 Devonshire Way, San Francisco. My business or occupation is Labor Representative.

My qualifications for said office are as follows: Long service in labor and civic activities have made me thoroughly familiar with San Francisco's needs and problems. I have been secretary of the San Francisco Labor Council since 1950. I have served five years on the Board of Education and was President in 1950. I have served on the Planning Commission, been a delegate to the Mayor's, Governor's and White House Conferences on Aging, am a member of the Citizens Charter Revision Committee, the Mayor's Bond Screening Committee and the Bay Area Advisory Committee on Minority Problems. These and many other civic activities qualify me to serve as a supervisor.

Pursuant to the provisions of Section 175 of Charter of said City and County, I desire that the following designation "Labor Representative" be placed immediately under my name as it will appear on all ballots at the General Municipal Election to be held November 7, 1961.

Signature of Candidate: GEORGE W. JOHNS.

Subscribed before me and filed this 18th day of September, 1961.

CHAS. A. ROGERS,
Registrar of Voters.

The sponsors for George W. Johns are:

Jos. L. Belardi, 89 Woodhaven Court; President of the Cooks Union Local 44.
Hamilton T. Boswell, 164 - 6th Ave.; Minister, Jones Methodist Church.
John F. Brady, 1296 - 36th Ave.; Associate Superintendent Schools (Retired).
John P. Figone, Jr., 1046 Union St.; Travel Agent.
Daniel V. Flanagan, 2401 Green St.; Regional Director, AFL-CIO.
Charles J. Foehn, 3473 - 19th St.; Vice President Int. Bro. of Electrical Workers.
Terry A. Francois, 1608 - 10th Ave.; Attorney at Law.
Herman E. Gallegos, 1015 Brussels St.; Intergroup Relations Official.
Louis Garcia, 60 Borica St.; Attorney.
Claude H. Jinkerson, 109 Denslowe Drive; Union Representative.
George Killion, 350 Arballo Drive; Steamship Business.
Don Lastreto, M. D., 96 Miraloma Drive; M. D.
Cyril Magnin, 950 Mason St.; Merchant.
A. F. Mailloux, 45 Marietta Dr.; Secty. Bldg. & Constr. Trades Council.
Emerson O. Midyett, 410 Pierce St.;
Member Advisory Com. Nat. Council Senior Citizens.
Jane Morrison, 2590 Greenwich St.; Radio Publicity Writer.
Wendell J. Phillips, 275 Graystone Terrace; Secretary—Labor Union.
Adolph P. Schuman, 2701 - 16th St.; Mfg.
Benjamin H. Swig, 950 Mason St.; Hotel Operator.
Gilbert Gang-Nom Woo, 4114 California St.; Editor.

For Supervisor
W. HARRY JOHNS

I hereby declare myself a candidate for the office of Supervisor for the City and County of San Francisco, State of California, to be voted for at the General Municipal Election to be held in the said City and County on November 7, 1961, and declare the following to be true:

That I shall have been a resident of the City and County of San Francisco for a period of at least five years and an elector thereof for a period of at least one year immediately prior to the time for taking such office: That my name is W. Harry Johns. My residence address is at No. 340 Hayes Street, San Francisco. My business or occupation is Real Estate School & Brokerage.

My qualifications for said office are as follows: Over 15 years in the real estate field has equipped me with a solid background of practical experience, and with five years dedicated to intensive study of real estate law, assures the citizenry that the complaints of the oppressed concerning housing, redevelopment, welfare, hospitalization, and the clarification of the new Housing Code will be greatly assisted with this candidate. The relief from excessive taxes through conducting lotteries, bingo and raffles at a percentage to the City is possible. Internal Revenue has sanctioned it, so can you.

Pursuant to the provisions of Section 175 of Charter of said City and County, I desire that the following designation "Realtor" be placed immediately under my name as it will appear on all ballots at the General Municipal Election to be held November 7, 1961.

Signature of Candidate: W. HARRY JOHNS.

Subscribed before me and filed this 19th day of September, 1961.

CHAS. A. ROGERS,
Registrar of Voters.
By P. LEMONE,
Deputy Registrar of Voters.

The sponsors for W. Harry Johns are:

Clay W. Board, 4708 - 17th St.; Realtor.
Willie D. Board, 4708 - 17th St.; Housewife.
Harry Brown, 2547 - 47th Ave.; Real Estate Broker.
John J. Davids, 2580 Polk St. #5; Claims Representative.
Sam A. Eiwaz, 440 Noe St.; Real Estate Broker.
Jos. H. Falkowich, 909 Geary St.; Taxicab Owner.
William P. Glover, 1901 - 16th Ave.;
Real Estate Salesman—(Pet Food Supplies Owner).
Al Hicks, 770 Page St.; Labor Relations—U. S. Steel Corporation.
Mrs. Doris C. J. Prince, 526 Joost Ave.; Secretary.
Rev. Clinton W. Rogers, 766 Brussels St.; Minister.
Aaron Ward, 60 Camp St.; Real Estate Manager.

For Supervisor

ROBERT O. JONES

I hereby declare myself a candidate for the office of Supervisor for the City and County of San Francisco, State of California, to be voted for at the General Municipal Election to be held in the said City and County on November 7, 1961, and declare the following to be true:

That I shall have been a resident of the City and County of San Francisco for a period of at least five years and an elector thereof for a period of at least one year immediately prior to the time for taking such office: That my name is Robert O. Jones. My residence address is at No. 440 Post Street, San Francisco. My business or occupation is Metal Lather.

My qualifications for said office are as follows: R. O. (Inspector Bob) Jones of Inspector Bob's Life Saving Enterprises has more skill and ability at safety programs to save lives from accidents and disasters than any supervisor or candidate. His ability is needed most on the board of supervisors. Nations number one expert on Earthquakeproofing—Fireproofing—Subway—Subway stations—Safety zones—Pedestrian—Auto-School—Fire safety programs. Studied Subways—Tunnels—Bay tube—Causeways—Bridges—Knows bay depths—Hills—Elevations—Zoning—Estimating—Designing—Budgeting—Wants up to date fire-proof building laws, financing—Knows city and its needs. Will protect citizens interest. California birth. San Francisco Mother. California Father.

Pursuant to the provisions of Section 175 of Charter of said City and County, I desire that the following designation "Metal Lather" be placed immediately under my name as it will appear on all ballots at the General Municipal Election to be held November 7, 1961.

Signature of Candidate: ROBERT O. JONES.

Subscribed before me and filed this 15th day of September, 1961:

CHAS. A. ROGERS,
Registrar of Voters.
By HAROLD J. O'DONNELL,
Deputy Registrar of Voters.

The sponsors for Robert O. Jones are:

Harold L. Cody, 15 Inverness Drive; Contractor.
Julian Richardson, 1216 Fillmore St.; Printer.
Raye G. Richardson, 1216 Fillmore St.; Office Manager—Success Printing Co.
George L. Albright, 231 Miramar Ave.; Service Station Operator.
Howard Burton, 643 Webster St., Apt. 3; Self Moving.
James A. Carter, 850 Baker St.; Dining Car Cook.
Artice Crawford, 1739 O'Farrell St.; Bartender.
Gus H. Davis, 1019 Hollister St.; Student.
George Dozier, 1028 Golden Gate Ave.; Labor.
Cecil Hooper, 2033 Pierce St.; Presser from Local 3010.
Vincent B. Lynch, 2129-A 24th St.; Circulation Manager (Sun-Reporter).
Elmo Ollison, 129 Marview Way; C-104 Janitor.

For Supervisor
W. H. (BILL) LAMMERS

I hereby declare myself a candidate for the office of Supervisor for the City and County of San Francisco, State of California, to be voted for at the General Municipal Election to be held in the said City and County on November 7, 1961, and declare the following to be true:

That I shall have been a resident of the City and County of San Francisco for a period of at least five years and an elector thereof for a period of at least one year immediately prior to the time for taking such office: That my name is W. H. (Bill) Lammers. My residence address is at No. 4015-18th Street, San Francisco. My business or occupation is Coin Dealer.

My qualifications for said office are as follows: I have had service in the armed forces and feel I can assist the veterans in securing any rights and privileges as is their do, also I have been doing research into housing and welfare of the senior citizens, medical, etc., with the intent of helping them to secure assistance without loss of dignity. Having been a union member for many years and now a small businessman I feel I will be able to assist labor in better relations with business in a manner helpful to both but no loss of prestige to either.

Pursuant to the provisions of Section 175 of Charter of said City and County, I desire that the following designation "Coin Dealer" be placed immediately under my name as it will appear on all ballots at the General Municipal Election to be held November 7, 1961.

Signature of Candidate: W. H. LAMMERS.

Subscribed before me and filed this 8th day of September, 1961.

CHAS. A. ROGERS,
Registrar of Voters.
By KENNETH J. LONG,
Deputy Registrar of Voters.

The sponsors for W. H. (Bill) Lammers are:

Violet Lammers, 4015 - 18th St.; Unit Control Clerk—Wholesale Shoes.
Leo J. Champagne, 273 Justin Drive; Electrical Engineer.
James L. Hole, 35 Colby St.; Salesman.
J. F. (Jack) Kennedy, 3970 - 19th St.; Electrician Retired.
Violet Morningstar, 4015 - 18th St.; Commercial Bank teller.
John J. Naegelin, 4012 - 19th St.; Machinist.
Leland H. Perry, 1377-A 9th Ave.; Real Estate Broker.
Travis R. Roy, 541 Washington St.; Boot Black.
Gabriel Salomon, 257 Cumberland St.; Insurance Broker.
A. J. Schomacker, 107 Marietta Dr., Optician.

For Supervisor
ERNEST LOTTI

I hereby declare myself a candidate for the office of Supervisor for the City and County of San Francisco, State of California, to be voted for at the General Municipal Election to be held in the said City and County on November 7, 1961, and declare the following to be true:

That I shall have been a resident of the City and County of San Francisco for a period of at least five years and an elector thereof for a period of at least one year immediately prior to the time for taking such office: That my name is Ernest Lotti. My residence address is at No. 59 Cuvier Street, San Francisco. My business or occupation is Union Executive.

My qualifications for said office are as follows: I wish to promote a better representation of our districts and elect supervisors by districts. I will attempt to stop waste of tax monies, used in continuous surveys of our traffic problems and maps and surveys later put aside and never used.

Pursuant to the provisions of Section 175 of Charter of said City and County, I desire that the following designation "Union Executive" be placed immediately under my name as it will appear on all ballots at the General Municipal Election to be held November 7, 1961.

Signature of Candidate: ERNEST LOTTI.

Subscribed before me and filed this 12th day of September, 1961.

CHAS. A. ROGERS,
Registrar of Voters.
By P. LEMONE,
Deputy Registrar of Voters.

The sponsors for Ernest Lotti are:

Mrs. Laura Lotti, 59 Cuvier St.; Housewife.
Anthony Cancilla, 15 Sweeny St.; Union Official.
Nathan Cohn, 510 Castenada Ave.; Attorney at Law.
Joseph J. Diviny, 125 Cambon Dr.; Labor Rep.
Michael J. Driscoll, 301 St. Francis Blvd.; Mortician.
Eugene J. Geiger, 28 Parker Ave.; Dept. Store Owner.
Stephen F. Gilligan, 594 London St.; Labor Official.
Thomas E. Gosland, 548 Elizabeth St.; Building Supt. Eagles Hall.
Harry H. Grossman, 16 Lagunitas Drive; Insurance Broker.
John F. Henning, 185 Westwood Drive;
Director, State Dept. of Industrial Relations.
Arthur T. Jenkins, 2194 - 26th Ave.; Bank Manager.
Joseph I. Kelly, 460 Magellan Ave.; Attorney.
Adolph M. Koven, 2199 Divisadero St.; Attorney at Law.
Dr. Louis K. Lichtenstein, 235 Buckingham Way; Dentist.
Albert F. Lotti, 150 Midcrest Way; Salesman.
Elmer J. Lycett, 206 Genebern Way; Vice President Goodyear Rubber Co.
Joseph F. Rae, 385 Church St.; Printer and Publisher.
Emilio Ruta, 2824 - 23rd St.; Retired Real Estate Broker.
James C. Syme, 3045 Mission St.; Sec't Treasurer Union Label Section S. F.

For Supervisor
CHARLES MARSALLI

I hereby declare myself a candidate for the office of Supervisor for the City and County of San Francisco, State of California, to be voted for at the General Municipal Election to be held in the said City and County on November 7, 1961, and declare the following to be true:

That I shall have been a resident of the City and County of San Francisco for a period of at least five years and an elector thereof for a period of at least one year immediately prior to the time for taking such office: That my name is Charles Marsalli. My residence address is at No. 1250 Jones Street, San Francisco. My business or occupation is President, Royal Crown Coffee Co.

My qualifications for said office are as follows: A successful businessman who has spent his life serving the people of San Francisco. I have gained much knowledge of the needs and problems of the people and community. I feel qualified to turn the talk and planning that has characterized our government into action that will produce results. My every business endeavor has been successful and I have enjoyed a happy relationship with my employees. My wife and I successfully operate the Royal Crown Coffee Co. and Marsalli's Restaurant. I know that I can capably use my talents for the benefit of San Francisco.

Pursuant to the provisions of Section 175 of Charter of said City and County, I desire that the following designation "Restaurateur" be placed immediately under my name as it will appear on all ballots at the General Municipal Election to be held November 7, 1961.

Signature of Candidate: CHARLES MARSALLI.

Subscribed before me and filed this 11th day of September, 1961.

CHAS. A. ROGERS,
Registrar of Voters.

The sponsors for Charles Marsalli are:

Phyllis Marsalli, 1250 Jones St.; Housewife.
Fred G. Ainslie, 1346 Polk St.; Insurance Broker.
Norman Altfield, 2196 Pacific Ave.; President California Notion & Toy Co.
Ivan A. Anixter, 2590 Pacific Ave.; Merchant.
Arthur C. Balling, 35 Alpine Terrace; Plumbing & Heating Contractor.
John Battaglia, 3731 Divisadero St.; Pharmacist.
Emilio Biordi, 2219 Scott St.; Importer.
John J. Casey, 3125 Pacheco St.; Insurance Broker.
George H. Cerasi, 524 Columbus Ave.; Hotel & Apt. House Owner.
Edwin T. Golden, 3830 Clay St.; Insurance Executive.
Phil Goldstein, 550 Geary St.; Jobber—Sporting Goods.
Robert Grison, 2296 Vallejo St.; Restaurant Owner.
Joseph H. Kushner MD, 35 Presidio Terrace; Doctor of Medicine.
Robert M. Land, 2820 Gough St.; Merchant.
Wanda Q. Lahanier, 1150 Union St.; Attorney.
Francis E. O'Rourke, 1770 Pacific Ave.; Management Consultant.
Albert Samuels, 1880 Jackson St.; Jeweler.
Louis Saroni, 3746 Jackson St.; Sales Representative.
Tom Spinosa, 215 Banks St.; President, Cavalier Records, Inc.
Dr. Henry A. Tagliaferri, 282 Silver Ave.;
Chief Oral Surgeon—St. Lukes' Hospital; State Harbor Commissioner.

For Supervisor

JOSEPH JOHN MIGLIOZZI

I hereby declare myself a candidate for the office of Supervisor for the City and County of San Francisco, State of California, to be voted for at the General Municipal Election to be held in the said City and County on November 7, 1961, and declare the following to be true:

That I shall have been a resident of the City and County of San Francisco for a period of at least five years and an elector thereof for a period of at least one year immediately prior to the time for taking such office: That my name is Joseph John Miglioizzi. My residence address is at No. 16 Alvarado Street, San Francisco. My business or occupation is Small Businessman.

My qualifications for said office are as follows: I am married to the former Louise Lavezzoli, and we are the parents of a son. I am presently engaged in the successful operation of a small moving and storage business. I know the problems of the small businessman and also those of the man who works for his livelihood. I advocate the expansion of City Recreational activities for our children and oppose the undirected extension of freeways, feeling that their further construction will mar the natural beauty of this great City. The loss of industry to this great City must be stopped.

Pursuant to the provisions of Section 175 of Charter of said City and County, I desire that the following designation "Small Businessman" be placed immediately under my name as it will appear on all ballots at the General Municipal Election to be held November 7, 1961.

Signature of Candidate: JOSEPH JOHN MIGLIOZZI.

Subscribed before me and filed this 15th day of September, 1961.

CHAS. A. ROGERS,
Registrar of Voters.
By HAROLD J. O'DONNELL,
Deputy Registrar of Voters.

The sponsors for Joseph John Miglioizzi are:

Louise Miglioizzi, 16 Alvarado St.; Housewife.
Timothy Mahony, 251 Byxbee St.; U. S. Navy (Retired).
Mary Lavezzoli, 16 Alvarado St.; Housewife.
Emmet F. Hagerty, 527 Arch St.; Attorney at Law.
Mrs. Margaret Ann Street, 1638 - 45th Ave.; Housewife.
Emanuel B. Spinrad, 3131 Noriega St.; Public Accountant.
Francis J. McAulay, 247 De Montford Ave.; Office Supervisor.
Rose Thompson, 640 Kirkham St.; Housewife.
Clara Figoni, 29 Ottawa Ave.; Bookkeeper.
Mrs. Ann S. Dippel, 1280 Lombard St.; Civic Betterment Participations.
Anthony S. De Vincenzi, 1643 Quesada Ave.; Food Manufacturer.
Edith E. Meagles, 1431 - 16th Ave.; Housewife.
George A. Wilson, 2285 Bay St.; Apt. House Owner & Manager.
Catherine Ruth Lee, 636 Washington St.; Housewife.
Andy Ahern, 190 Evelyn Way; Union Official.
Joseph Angel, 2210 - 36th Ave.; Food Merchant.
Salvatore T. Viscuso, 171 Andover St.; Printing Pressman.
Joseph F. Sheehan, 111 Genebern Way; Real & Insurance.
Angelo Rolando, 3276 Harrison St.; Real Estate Broker.
Isidore Tani, 1946 - 32nd Ave.; Television Service Dealer.

For Supervisor
JACK MORRISON

I hereby declare myself a candidate for the office of Supervisor for the City and County of San Francisco, State of California, to be voted for at the General Municipal Election to be held in the said City and County on November 7, 1961, and declare the following to be true:

That I shall have been a resident of the City and County of San Francisco for a period of, at least five years and an elector thereof for a period of at least one year immediately prior to the time for taking such office: That my name is Jack Morrison. My residence address is at No. 2590 Greenwich Street, San Francisco. My business or occupation is Newspaper Reporter.

My qualifications for said office are as follows: I have had ten years' experience as a newspaper reporter covering San Francisco and California government. I was the runner-up candidate for supervisor in 1959. I believe the city's problems demand a new spirit of initiative and progress on the Board of Supervisors. We must satisfy our critical need for more housing that the middle-income family can afford, achieve faster and better public transportation, revitalize our city planning, and protect San Francisco from freeway blight. We must insist that all of us, whatever our economic level, whatever our color or creed, share equitably in the progress of San Francisco.

Pursuant to the provisions of Section 175 of Charter of said City and County, I desire that the following designation "Newspaper Reporter" be placed immediately under my name as it will appear on all ballots at the General Municipal Election to be held November 7, 1961.

Signature of Candidate: JACK MORRISON.

Subscribed before me and filed this 19th day of September, 1961.

CHAS. A. ROGERS,
Registrar of Voters.

The sponsors for Jack Morrison are:

Jane Morrison, 2590 Greenwich St.; Radio Publicity Writer.
Ann W. Alanson, 530 Euclid Ave.; Housewife.
Jos. L. Belardi, 89 Woodhaven Court; President of Cooks Union Local 44.
Franklyn K. Brann, 1270 - 28th Ave.; Attorney at Law.
Dr. Arthur H. Coleman, M.D., 698 Los Pamos Drive; Physician.
Charles de Y. Elkus, 1010 Francisco St.; Lawyer.
John P. Figone, Jr., 1046 Union St.; Travel Agent.
Louis Garcia, 60 Borica St.; Attorney.
Mrs. Henry F. Grady, 850 Powell St.; Housewife.
F. D. Haynes, 1832 - 16th Ave.; Clergyman.
Elizabeth Heller, 3157 Jackson St.; Public Relations.
John F. Henning, 185 Westwood Drive;
Director State Department of Industrial Relations.
Claude H. Jinkerson, 109 Denslowe Drive; Union Representative.
Robert S. Lauter, 23 Presidio Terrace; Attorney.
A. F. Mailloux, 45 Marietta Dr.; Secty. Bldg. & Constr. Trades Council.
George R. Moscone, 2735 Gough St.; Attorney.
William Moskovitz, 1901 California St.; Real Estate Investments.
Gerald J. O'Gara, 2845 Green St.; Attorney at Law.
George W. Ong, 52 Almaden Court; Sales Supervisor.
Atherton Phleger, 2623 Divisadero St.; Lawyer.

For Supervisor
ALAN H. NICHOLS

I hereby declare myself a candidate for the office of Supervisor for the City and County of San Francisco, State of California, to be voted for at the General Municipal Election to be held in the said City and County on November 7, 1961, and declare the following to be true:

That I shall have been a resident of the City and County of San Francisco for a period of at least five years and an elector thereof for a period of at least one year immediately prior to the time for taking such office: That my name is Alan H. Nichols. My residence address is at No. 101 Alton Avenue, San Francisco. My business or occupation is Attorney.

My qualifications for said office are as follows: A native Californian and a Korean War veteran, active in church and neighborhood affairs, I am a practicing attorney with deep convictions that San Francisco needs new and vigorous leadership, restoring the "human equation" to City Government and emphasizing total development of the neighborhood way of life. Married to a former San Francisco public school teacher, we have two fine children and so we have a stake in San Francisco not just today but tomorrow too. You have five votes for Supervisor and I ask that you give me one of those votes.

Pursuant to the provisions of Section 175 of Charter of said City and County, I desire that the following designation "Attorney" be placed immediately under my name as it will appear on all ballots at the General Municipal Election to be held November 7, 1961.

Signature of Candidate: ALAN H. NICHOLS.

Subscribed before me and filed this 13th day of September, 1961.

CHAS. A. ROGERS,
Registrar of Voters.

The sponsors for Alan H. Nichols are:

Lolita Lois Nichols, 101 Alton Ave.; Homemaker.
Fred Campagnoli, 2609 Larkin St.; Attorney.
Allan E. Charles, 850 Francisco St.; Lawyer.
Wm. Hunt Conrad, 1948 Pacific Ave.;
President, Volunteers for Better Government.
A. F. Derre', 170 San Fernando Way; Banker.
Tom T. Hoshiyama, 745 - 11th Ave.; Wholesale Florist.
Mrs. Fred H. Huie, 672 - 16th Ave.; Housewife.
Roger D. Lapham Jr., 2233 Lyon St.; Insurance Broker.
Jack M. Lipman, 591 Spruce St.; Neighborhood Builder.
Sandra Mattos, 1417 - 37th Ave.; Elementary School Teacher.
Clarissa Shortall McMahon, 2201 Leavenworth St.; Attorney at Law.
William J. Nelligan, 495 Marietta Dr.; Telephone Employee.
Angelo T. Mountanos, 1526 Plymouth Ave.;
Greek-American Radio Hour—Director.
Andrew Downey Orrick, 2509 Scott St.; Attorney at Law.
Henry R. Rolph, 2626 Lyon St.; Attorney at Law.
Claiborne M. Sanders, 956 Post St.; Veterans Leader.
Henry M. Sante, 515 O'Farrell St.; Public Accountant.
James E. Stratten, 662 - 15th Ave.;
Exec. Dir. of Booker T. Wash. Community Center,
Dwight L. Wilbur, MD, 140 Sea Cliff Ave.; Physician.
Stephen A. Zellerbach, 24 Presidio Terrace; Businessman.

For Supervisor

L. PATRICK (PAT) O'BRIEN

I hereby declare myself a candidate for the office of Supervisor for the City and County of San Francisco, State of California, to be voted for at the General Municipal Election to be held in the said City and County on November 7, 1961, and declare the following to be true:

That I shall have been a resident of the City and County of San Francisco for a period of at least five years and an elector thereof for a period of at least one year immediately prior to the time for taking such office: That my name is L. Patrick (Pat) O'Brien. My residence address is at No. 2470-32nd Avenue, San Francisco. My business or occupation is Businessman.

My qualifications for said office are as follows: Homeowner, married, two children. Intensely interested in the neighborhoods having a stronger representation on our Board of Supervisors. We must look forward and provide for the future of our young people, for the future of our City depends on the future of her youth. For the welfare and peace of mind of our Senior Citizens we should have additional recreation and community centers. Expenditures should be made wisely for the best interest of all the people. Vice-Chairman San Francisco Democratic County Committee, member Governor's Committee on Aid to Aged, active in youth guidance and training. Past delegate San Francisco Labor Council.

Pursuant to the provisions of Section 175 of Charter of said City and County, I desire that the following designation "Businessman" be placed immediately under my name as it will appear on all ballots at the General Municipal Election to be held November 7, 1961.

Signature of Candidate: L. PATRICK O'BRIEN.

Subscribed before me and filed this 18th day of September, 1961.

CHAS. A. ROGERS,
Registrar of Voters.
By HAROLD J. O'DONNELL,
Deputy Registrar of Voters.

The sponsors for L. Patrick (Pat) O'Brien are:

Mrs. Tillie O'Brien, 2470 - 32nd Ave.; Housewife.
Maurice Borden, 1757 - 18th Ave.; Market Manager.
Thomas F. Connolly, 121 Dolores St.; Labor Official.
Frank J. Doherty, 2143 - 42nd Ave.;
Traffic Representative States Marine Isthmian Lines.
Murray Frohman, 2243 Balboa St.; Insurance Broker.
Harold S. Gilbert, 1750 Vallejo St.; Land Management.
Thomas E. Gosland, 548 Elizabeth St.; Building Supt. Eagles Hall.
Emmet F. Hagerty, 527 Arch St.; Attorney at Law.
A. W. MacNichol, 1456 Fulton St.; Service Contractor Pier 5 S. F.
Sol J. Milrad, 2078 - 36th Ave.; Businessman.
John J. Mullane, Jr., 15 Balceta Ave.; Attorney.
Mrs. John J. Mullane Jr., 15 Balceta Ave.; Housewife.
John W. Murphy, 2570 - 32nd Ave.; Longshoreman.
John M. Ratto, 1215 Bay St.; Real Estate Broker.
Angelo Rolando, 3276 Harrison St.; Real Estate Broker.
John B. Torrenza, 701 Fell St.; Salesman.

For Supervisor

THOMAS P. O'TOOLE

I hereby declare myself a candidate for the office of Supervisor for the City and County of San Francisco, State of California, to be voted for at the General Municipal Election to be held in the said City and County on November 7, 1961, and declare the following to be true:

That I shall have been a resident of the City and County of San Francisco for a period of at least five years and an elector thereof for a period of at least one year immediately prior to the time for taking such office: That my name is Thomas P. O'Toole. My residence address is at No. 1319-38th Avenue, San Francisco. My business or occupation is Insurance executive.

My qualifications for said office are as follows: Educated public schools, St. Mary's College, American Institute of Banking and Commercial Law. Married, father of seven daughters, home owner, enabling me therefore to understand the problems of the father, housewife, and our children. Past Commander American Legion No. 538. Regarding the Blyth-Zellerbach Report: I believe the small home owner should have more voice and consideration in city affairs. Our parks and recreation centers should not be sold. We wish to retain our neighborhood police stations: our right to elect our assessor, sheriff, treasurer and other public officials. Freeways and parking problems should conform to the will of the people.

Pursuant to the provisions of Section 175 of Charter of said City and County, I desire that the following designation "Insurance executive" be placed immediately under my name as it will appear on all ballots at the General Municipal Election to be held November 7, 1961.

Signature of Candidate: THOMAS P. O'TOOLE.

Subscribed before me and filed this 21st day of September, 1961.

CHAS. A. ROGERS,
Registrar of Voters.
By HAROLD J. O'DONNELL,
Deputy Registrar of Voters.

The sponsors for Thomas P. O'Toole are:

John W. Alcorn, 3962 Clay St.; Secretary—Veterans Political Council.
Mrs. Vernon A. Leonardi, 693 Dartmouth St.;
President of McLaren Park Improvement Club.
Maurice Lafayette, 124 Baden St.; Businessman.
George W. Poultney, 727 Duboce Ave.; Representative Actors Equity Assn.
Ernest E. Busk, 278 Second Ave.; Owner—Busvan Moving & Storage Co.
Mrs. Thomas R. Best, 1359 - 45th Ave.;
Corresponding Secretary Great Highway Club.
Nancy V. Yates, 609 - 22nd Ave.; Bookkeeper.
Albert J. DeMartini, 734 - 22nd Ave.; Salesman.
Leo Cohan, 2771 - 38th Ave.; Furniture Manufacturer.
Joseph V. Harmon, 247 Montana St.; Checker.
Frank L. Sinclair, 337 Fulton St.; Stationary Engineer.
Mrs. Margaret E. Smith, 1319 - 38th Ave.; Sec. S. F. Property Owners League.
Al J. Quinn, 32 Hidalgo Terrace; Public Accountant.
Val. Molkenbuhr, 2579 - 15th Ave.; Wholesale Jeweler.
Warren I. Gabrielli, 524 Columbus Ave.; Contractor.
Mary J. Busk, 278 - 2nd Ave.; Bookkeeper.
John Knox Lynch, 1225 - 29th Ave.; Educational Executive.

For Supervisor
HAYDEN PERRY

I hereby declare myself a candidate for the office of Supervisor for the City and County of San Francisco, State of California, to be voted for at the General Municipal Election to be held in the said City and County on November 7, 1961, and declare the following to be true:

That I shall have been a resident of the City and County of San Francisco for a period of at least five years and an elector thereof for a period of at least one year immediately prior to the time for taking such office: That my name is Hayden Perry. My residence address is at No. 32 Hattie Street, San Francisco. My business or occupation is Lithographer.

My qualifications for said office are as follows: I am a worker and trade unionist, endorsed by the Socialist Workers Party. The biggest issue facing us is the threat of nuclear war. The fallout shelter campaign is useless for survival and only a means of indoctrinating us for war. I propose banning all nuclear tests and initiating total disarmament; removing American and foreign troops from Germany and all foreign bases. No war over Berlin! I oppose our government's hostility to Cuba. The Cubans are building a Socialist society that will end poverty. I oppose any attempts to restore the old order. No more invasions!

Pursuant to the provisions of Section 175 of Charter of said City and County, I desire that the following designation "Lithographer" be placed immediately under my name as it will appear on all ballots at the General Municipal Election to be held November 7, 1961.

Signature of Candidate: HAYDEN H. PERRY.

Subscribed before me and filed this 14th day of September, 1961.

CHAS. A. ROGERS,
Registrar of Voters.
By HAROLD J. O'DONNELL,
Deputy Registrar of Voters.

The sponsors for Hayden Perry are:

Mrs. Esther W. Perry, 32 Hattie St.; Beauty Operator.
Marie Bristol, 557 Guerrero St.; Clerk-typist.
Aaron Chapman, 222 Clayton St.; Lens Grinder.
Marie Chapman, 222 Clayton St.; Housewife.
Patricia A. Dimas, 3452 - 16th St.; TV & Radio Estimator.
Asher F. Harer, 149 Detroit St.; Longshoreman.
Lucile G. Harer, 524 Avalon Ave.; Housewife.
Joan Jordan, 77 Bradford St.; Lithograph Factory Worker.
George Le Flore Jr., 327 Garfield St.; Warehouseman.
Sue Mattingly, 2331 Market St.; Housewife.
Helen Bennett Maupin, 616 Shrader St.; Retired.
George C. Myland, 404 Oak St.; Paper Worker.
Alexander Shumacher, 1119 Shotwell St.; Elevator Operator.
Charlie Webb, 941 Hayes St.; Retired.

For Supervisor
AL J. QUINN

I hereby declare myself a candidate for the office of Supervisor for the City and County of San Francisco, State of California, to be voted for at the General Municipal Election to be held in the said City and County on November 7, 1961, and declare the following to be true:

That I shall have been a resident of the City and County of San Francisco for a period of at least five years and an elector thereof for a period of at least one year immediately prior to the time for taking such office: That my name is Al J. Quinn. My residence address is at No. 32 Hidalgo Terrace, San Francisco. My business or occupation is Public Accountant.

My qualifications for said office are as follows: My residence has been in the Mission District for over 50 years. I am in favor of the election of Supervisors Blake, Tinney & Tamaras, whom I consider to be fine public servants. I favor a city wide 5 cent carfare for all citizens. Elimination of all passes, with free rides for the Blind, Sisters of Religious Orders and Senior Citizens, over 65 with incomes of less than \$1,200.00 annually and a 50c roundtrip fare to Candlestick Park. Lower taxes and the elimination of useless Commissions. We need more GOOD GOVERNMENT, for the finest city in world—San Francisco.

Pursuant to the provisions of Section 175 of Charter of said City and County, I desire that the following designation "Public Accountant" be placed immediately under my name as it will appear on all ballots at the General Municipal Election to be held November 7, 1961.

Signature of Candidate: AL J. QUINN.

Subscribed before me and filed this 22nd day of September, 1961.

CHAS. A. ROGERS,
Registrar of Voters.
By HAROLD J. O'DONNELL,
Deputy Registrar of Voters.

The sponsors for Al J. Quinn are:

Ralph E. Boches, 3945 - 20th St.; Lawyer.
Agnes Brady, 273 Randall St.; Retired.
Annie Cassidy, 4058 Army St.; Retired.
A. L. Derby, 800 Church St.; Retired.
Mrs. Helen Finn, 215 Dorland St.; Housewife.
Ella V. Keating, 99 Jersey St.; Retired Telephone Operator Sr.
John T. Kelly, 167 Dolores St.; Retired Longshoreman.
William J. Nelligan, 495 Marietta Dr.; Telephone Employee.
Mrs. Mary F. O'Brien, 222 Day St.; Housewife.
Ethel M. Sibley, 265 Dorland St.; Housewife.
Valerie Woersching, 27 Farallones St.; Housewife.

For Supervisor

JOSE JULIO SARRIA

I hereby declare myself a candidate for the office of Supervisor for the City and County of San Francisco, State of California, to be voted for at the General Municipal Election to be held in the said City and County on November 7, 1961, and declare the following to be true:

That I shall have been a resident of the City and County of San Francisco for a period of at least five years and an elector thereof for a period of at least one year immediately prior to the time for taking such office: That my name is Jose Julio Sarria. My residence address is at No. 759-14th Avenue, San Francisco. My business or occupation is Restaurant-Manager.

My qualifications for said office are as follows: My Platform is equality before the law as so ably stated in the inscription on the new Hall of Justice: "The faithful and impartial enforcement of the laws with equal and exact Justice to all of whatever state or persuasion."

Pursuant to the provisions of Section 175 of Charter of said City and County, I desire that the following designation "Entertainer—Host" be placed immediately under my name as it will appear on all ballots at the General Municipal Election to be held November 7, 1961.

Signature of Candidate: JOSE JULIO SARRIA.

Subscribed before me and filed this 8th day of September, 1961.

CHAS. A. ROGERS,

Registrar of Voters.

By HAROLD J. O'DONNELL,
Deputy Registrar of Voters.

The sponsors for Jose' Julio Sarria are:

Hector Acevedo, 1122 Sutter St.; Bank Adjuster.

Dick Andreetta, 464 Columbus Ave.; Hotel Operator.

Edward J. Farquhar, 759 - 14th Avenue; Fountain Man.

Maurice Wm. Gerry, 587 Castro St.; Hair Stylist.

Michael P. Hughes, 759 - 14th Ave.; Waiter.

Jimmie E. James, 1590 Washington St.; Entertainer.

Donald K. Loveless, 3031 Steiner Street; Purchasing Agent.

Ileene E. MacAdam, 3821 Anza St.; Bookkeeper.

James W. McGinnis, 1056 - 14th St.; Musician.

Robert H. McKinney, 169 Noe St.; Accountant.

Robert E. Newman, 2555 Market St.; Secretary.

Guy Strait, 1154 Kearney St.; Salesman.

For Supervisor
DONALD J. SULLIVAN

I hereby declare myself a candidate for the office of Supervisor for the City and County of San Francisco, State of California, to be voted for at the General Municipal Election to be held in the said City and County on November 7, 1961, and declare the following to be true:

That I shall have been a resident of the City and County of San Francisco for a period of at least five years and an elector thereof for a period of at least one year immediately prior to the time for taking such office: That my name is Donald J. Sullivan. My residence address is at No. 3508 Sacramento Street, San Francisco. My business or occupation is Attorney at Law.

My qualifications for said office are as follows: I am 43; an attorney in private practice in San Francisco for over 15 years; a graduate of the University of California in Political Science and of San Francisco Law School; I will impartially represent all districts and people of our City and give proper consideration to their problems, hopes, fears and desires; I strongly advocate an improved parking system, particularly in the neighborhoods; I will dedicate my uncompromising efforts to assure the people of San Francisco full value for every tax dollar spent. I ask you, the people of San Francisco, to vote for me.

Pursuant to the provisions of Section 175 of Charter of said City and County, I desire that the following designation "Attorney at Law" be placed immediately under my name as it will appear on all ballots at the General Municipal Election to be held November 7, 1961.

Signature of Candidate: DONALD J. SULLIVAN.

Subscribed before me and filed this 8th day of September, 1961.

CHAS. A. ROGERS,
Registrar of Voters.
By HAROLD J. O'DONNELL,
Deputy Registrar of Voters.

The sponsors for Donald J. Sullivan are:

Russell T. Ainsworth, 10 Funston Ave.; Attorney at Law.
John A. Bruton, 2531 - 38th Ave.; Attorney at Law.
Alicia C. Calderon, 499 Belvedere St.; Legal Secretary.
Ferd W. Callison, M. D., 1101 Green St.; Surgeon.
Russel L. Casey, 206 Woolsey St.; Insurance Man.
John Cordoni, 81 Collins St.; Bowling Alley Proprietor.
Irving Davis, 20 El Mirasol St.; Physician.
Doris Della Nina, 355 Serrano Drive; Buyer.
Joseph J. Dignan, 1018 Lombard St.; Lt. Col. USMCR (Ret).
Frank X. Harrigan, 1507 California St.; Salesman.
Frederick Hinnners, 49 Aquavista Way; Real Estate Broker.
A. J. Lathrop, 71 Paradise Ave.; Operating Engineers Local No. 3.
Robert L. Levy, 3070 - 24th Avenue; Attorney at Law.
Angelo L. Petrini, 1378 - 29th Ave.; Restaurant & Tavern Owner.
W. M. Pinney Jr.; 346 El Camino Del Mar; Attorney at Law.
Mrs. Lorraine Polo, 530 Burrows St.; Housewife.
Lemuel D. Sanderson, 2430 Hyde Street; Attorney at Law.
Charlotte M. Schwartz, 567 Corbett St.; Sales & Customer Relations.
Dorothy Stonich, 1326 San Bruno Ave.; Housewife.
Kam Y. Yuen, 1941 Leavenworth St.; Life Underwriter.

For Supervisor
JOHN L. SULLIVAN

I hereby declare myself a candidate for the office of Supervisor for the City and County of San Francisco, State of California, to be voted for at the General Municipal Election to be held in the said City and County on November 7, 1961, and declare the following to be true:

That I shall have been a resident of the City and County of San Francisco for a period of at least five years and an elector thereof for a period of at least one year immediately prior to the time for taking such office: That my name is John L. Sullivan. My residence address is at No. 90 Yukon Street, San Francisco. My business or occupation is General Contractor.

My qualifications for said office are as follows: Educated in City Public and Parochial schools and twenty years' building experience.

Pursuant to the provisions of Section 175 of Charter of said City and County, I desire that the following designation "General Contractor" be placed immediately under my name as it will appear on all ballots at the General Municipal Election to be held November 7, 1961.

Signature of Candidate: JOHN L. SULLIVAN.

Subscribed before me and filed this 18th day of September, 1961.

CHAS. A. ROGERS,
Registrar of Voters.
By P. LEMONE,
Deputy Registrar of Voters.

The sponsors for John L. Sullivan are:

Haskell Caro, 1770 - 29th Ave.; Real Estate Broker.
Elizabeth J. Clancy, 2046 - 23rd Ave.; Reg. Nurse.
Robert Clancy, 2046 - 23rd Ave.; Tavern Owner.
Kathleen L. Dunne, 739 - 41st Ave.; Housewife.
Sam Edelstein, 1337 Ortega St.; Printer.
Burton S. Froom, 235 Edgehill Way; Salesman.
Arthur J. Hogan, 240 Manor Drive; Lumber Merchant.
Arthur E. Menicucci, 675 Delano St.; Arc Electric Co. Owner.
Frank G. Norman, 1475 - 34th Ave.; Hardware Merchant.
Adolph Pardini, 745 Brazil Ave.; Concrete Contractor.
Estelle S. Robison, 133 Venus St.; Housewife.
Curtis R. Robison, 133 Venus St.; Tavern Owner.
Frank J. Ruggiero, 111 Middlefield Dr.; Real Estate—Insurance.
Daniel F. Sullivan, 251 Magellan Ave.; Real Estate Broker.
H. B. Williamson, 141 Moneta Way; Plumbing Contractor.

For Supervisor.

WARREN SULLIVAN

I hereby declare myself a candidate for the office of Supervisor for the City and County of San Francisco, State of California, to be voted for at the General Municipal Election to be held in the said City and County on November 7, 1961, and declare the following to be true:

That I shall have been a resident of the City and County of San Francisco for a period of at least five years and an elector thereof for a period of at least one year immediately prior to the time for taking such office: That my name is Warren Sullivan. My residence address is at No. 2101 Pacific Avenue, San Francisco. My business or occupation is Lawyer.

My qualifications for said office are as follows: I am a fourth generation San Franciscan, educated St. Brigid's, Galileo High School, USF, San Francisco Law School. World War II Veteran, National Judge Advocate, Regular Veterans, Member Veterans Political Council, American Legion, Native Sons (Guadalupe Parlor). Business and Professional groups. I have a fervent interest in and a thorough knowledge of civic affairs, and our problems: tax reduction, rapid transit, successful redevelopment program, improved school system, constructive fostering of juvenile adjustment. I advocate 5 cent carfare, benefits and housing for pensioners. I oppose destruction of homes by freeways. Dedicated to: Our city's progress, Our community's interest, Our people's welfare.

Pursuant to the provisions of Section 175 of Charter of said City and County, I desire that the following designation "Lawyer" be placed immediately under my name as it will appear on all ballots at the General Municipal Election to be held November 7, 1961.

Signature of Candidate: WARREN SULLIVAN.

Subscribed before me and filed this 19th day of September, 1961.

CHAS. A. ROGERS,
Registrar of Voters.

By HAROLD J. O'DONNELL,
Deputy Registrar of Voters.

The sponsors for Warren Sullivan are:

Dorothy Sullivan, 2101 Pacific Ave.; Housewife.
John J. Sullivan, 2101 Pacific Ave.; Former Supervisor.
Walter H. Ahlstrand, 818 Edinburgh St.; Retired.
Fred G. Ainslie, 1346 Polk St.; Insurance Broker.
Michael A. Desiano, 3250 Laguna St.; Contractor.
Phillip Greenfield, 240 Hyde St.; Retired.
J. R. Klawans, 27 Avila St.; Attorney.
Louis T. Kruger, 23 Miguel St.; Attorney at Law.
Wanda Q. Lahanier, 1150 Union St.; Attorney.
William McCabe, 2878 Jackson St.; Union Representative.
Daniel F. McCarthy, 67 Santa Ynez Ave.; Broker.
Ted McMahon, 190 - 15th Ave.; Retired Banker.
John D. Monaghan, 31 Grand View Ave.; Caterer.
William Moskovitz, 1901 California St.; Real Estate Investments.
James L. Quigley, 526 Funston Ave.; Retired Deputy Chief of Police.
Marietta P. Rice, 1371 - 40th Ave.; President of Gold Star Mothers.
Reed W. Robinson, 405 Serrano Drive; Candy Mfgr.
Arnold E. Walters, 1150 Greenwich St.; Business Executive.
Edward G. Zelinsky, 120 Sea Cliff Ave.; Painting Contr.

For Supervisor
PETER TAMARAS

I hereby declare myself a candidate for the office of Supervisor for the City and County of San Francisco, State of California, to be voted for at the General Municipal Election to be held in the said City and County on November 7, 1961, and declare the following to be true:

That I shall have been a resident of the City and County of San Francisco for a period of at least five years and an elector thereof for a period of at least one year immediately prior to the time for taking such office: That my name is Peter Tamaras. My residence address is at No. 35 San Rafael Way, San Francisco. My business or occupation is Owner Olympic Supply Company.

My qualifications for said office are as follows: A San Franciscan since infancy, 49 years old, Army Captain in World War II, graduate of local schools and University of California, majoring in business administration. I own and operate a local independent business concern; for six years was member and President of Board of Permit Appeals; since last March following my unsolicited appointment as Supervisor have conscientiously served all our people. San Francisco's natural assets, properly promoted, must assure its recognition as the world's greatest tourist and convention city. Much can and must be done to overcome problems of traffic, transit, housing, urban renewal, equal rights for all. My governmental and business experience, my most diligent efforts, are dedicated to solving these problems.

Pursuant to the provisions of Section 175 of Charter of said City and County, I desire that the following designation "Incumbent" be placed immediately under my name as it will appear on all ballots at the General Municipal Election to be held November 7, 1961.

Signature of Candidate: PETER TAMARAS.

Subscribed before me and filed this 11th day of September, 1961.

CHAS. A. ROGERS,
Registrar of Voters.

The sponsors for Peter Tamaras are:

Euthemia Tamaras, 35 San Rafael Way; Housewife.
Mrs. George Christopher, 55 Stonecrest Drive; Housewife.
Victor S. Abe, 725 - 19th Ave.; Attorney.
Dr. Peter T. Angel, 1867 - 15th Ave.; Dentist Retired.
Jefferson A. Beaver, 616 Los Paltos Drive; Executive.
Ben Blumenthal, 2101 Pacific Ave.; Importer.
A. F. Derre', 170 San Fernando Way; Banker.
Philip Dindia, 345 Banks St.; Business Representative Teamsters Union Loc. 85.
John P. Figone Jr., 1046 Union St.; Travel Agent.
G. B. Gillin, 295 Straford Drive; Real Estate and Insurance.
Mrs. Henry F. Grady, 850 Powell St.; Housewife.
Stuart N. Greenberg, 2106 Jackson St.; Bronze Manufacturer.
Donald M. Haet, 450 Magellan Ave.; Lawyer.
Wm. Kilpatrick, 2491 - 24th Ave.; Civil Service Commissioner.
John Max Moore, 2470 Broadway; Businessman.
Michael Riordan, 550 Laguna Honda Blvd.; Attorney at Law.
Albert Samuels, 1880 Jackson St.; Jeweler.
Henry Shue Tom, 2938 Taraval St.; Exec. Secretary—Y.M.C.A.
Thomas E. Twohig, 3425 - 23rd St.; Contractor.
Clarence J. Walsh, 124 Delano Ave.; Retired.

For Supervisor
JOSEPH E. TINNEY

I hereby declare myself a candidate for the office of Supervisor for the City and County of San Francisco, State of California, to be voted for at the General Municipal Election to be held in the said City and County on November 7, 1961, and declare the following to be true:

That I shall have been a resident of the City and County of San Francisco for a period of at least five years and an elector thereof for a period of at least one year immediately prior to the time for taking such office: That my name is Joseph E. Tinney. My residence address is at No. 1 Melba Avenue, San Francisco. My business or occupation is Attorney at Law.

My qualifications for said office are as follows: Incumbent Supervisor, Former President S. F. Planning Commission. Born in San Francisco, married, reside with wife, Helen, and children, Joseph and Marcella, at 1 Melba Avenue. Graduated from Junipero Serra, St. Paul's, St. Ignatius and University of San Francisco, where I taught in Law School. Former Assistant District Attorney; Law Practice 25 years. Platform: Efficiency, economy, further reductions in tax rate; Urban Renewal, Regional Planning, Rapid Transit; Complete Water and Airport Development; Preservation of Landmarks, Beauty and Open Space; Develop Tourist Trade, Commerce and Industry; Equal Rights, Good Schools, Regard for Senior Citizens. Affiliations: N.S.G.W., W.O.W., A.O.H., Mission Street Merchants, Mission Neighborhood Centers, S. F. Bar, St. Stephen's Men's Club.

Pursuant to the provisions of Section 175 of Charter of said City and County, I desire that the following designation "Incumbent" be placed immediately under my name as it will appear on all ballots at the General Municipal Election to be held November 7, 1961.

Signature of Candidate: JOSEPH E. TINNEY.

Subscribed before me and filed this 11th day of September, 1961.

CHAS. A. ROGERS,
Registrar of Voters.
By ALEX McCARTHY,
Deputy Registrar of Voters.

The sponsors for Joseph E. Tinney are:

Roger D. Lapham, Jr., 2233 Lyon St.; Insurance Broker.
Mrs. George Christopher, 55 Stonecrest Drive; Housewife.
J. F. Sullivan, Jr., 864 Francisco St.; Banker.
Mrs. John B. Molinari, 1262 Lombard St.; Housewife.
Philip Dindia, 345 Banks St.; Business Representative Teamsters Union Loc. 85.
Julia G. Porter, 142-27th Ave.; Housewife.
Thomas A. Maloney, 350 Missouri St.; Insurance Broker.
Mrs. Genevieve Castagnetto, 25 Vasquez Ave.; Housewife.
Thomas P. White, 411 Panorama Drive; Labor Union Official.
Adeline Williams M.D., 2380 San Bruno Ave.; Physician & Surgeon.
Cyril I. Magnin, 950 Mason St.; Merchant.
James S. Kearney, 1871-35th Ave.; Labor Official.
Gardner W. Mein, 2080 Gough St.; Executive.
Wm. Kilpatrick, 2491-24th Ave.; Civil Service Commissioner.
Louis M. Cole, 1958 Vallejo St.; Planning Commissioner.
E. F. Savio D.D.S., 1 Digby St.; Dentist.
Francis Louie, 1257 Jackson St.; Merchant.
Solomon E. Johnson, 435 Bright St.; Attorney at Law,
Yoritada Wada, 565-4th Ave.; Social Worker.
Louis Mazzera, 2 Maynard St.; Material Dealer.

For Supervisor
HAROLD TRESKUNOFF

I hereby declare myself a candidate for the office of Supervisor for the City and County of San Francisco, State of California, to be voted for at the General Municipal Election to be held in the said City and County on November 7, 1961, and declare the following to be true:

That I shall have been a resident of the City and County of San Francisco for a period of at least five years and an elector thereof for a period of at least one year immediately prior to the time for taking such office: That my name is Harold Treskunoff. My residence address is at No. 31 Majestic Avenue, San Francisco. My business or occupation is Waiter.

My qualifications for said office are as follows: I pledge to fight with all the resources at my command for more direct democratic participation by every citizen in the government of the City and County of San Francisco. We have bad schools, bad housing, rising juvenile delinquency, inadequate transportation, unfair labor conditions, short-sighted water-reserve planning, repeated violations of civil rights and individual liberties, because most of our boards and commissions are NOT directly nominated and elected by the people. I will cut the reins of power from the tentacles of the fake politicians and grafters. I will give the government back to the people.

Pursuant to the provisions of Section 175 of Charter of said City and County, I desire that the following designation "Waiter" be placed immediately under my name as it will appear on all ballots at the General Municipal Election to be held November 7, 1961.

Signature of Candidate: HAROLD TRESKUNOFF.

Subscribed before me and filed this 8th day of September, 1961.

CHAS. A. ROGERS,
Registrar of Voters.
By P. LEMONE,
Deputy Registrar of Voters.

The sponsors for Harold Treskunoff are:

Lois Treskunoff, 31 Majestic Ave.; House Wife.
Willie Brown, 101 De Long St.; Houseman.
Theodore S. Gomes, 44-3rd St.; Waiter.
Frank Lorio, 840 Filbert St.; Waiter.
Leo Louis, 798 Post St.; Waiter.
Jack T. Nichols, 815 O'Farrell St.; Waiter.
Sam Rosenberg, 4214 Irving St.; Waiter.
Oliver E. Seeman, 890 Geary St.; Bartender.
Henry Smith, 1424 Baker St. Apt. 116; Shoe Shine Proprietor.
George Soriano, 200 Andover St.; Waiter.
Meryl Washburn, 910 Geary St.; Bus Boy.

For Supervisor
ROBERT VANDERBILT

I hereby declare myself a candidate for the office of Supervisor for the City and County of San Francisco, State of California, to be voted for at the General Municipal Election to be held in the said City and County on November 7, 1961, and declare the following to be true:

That I shall have been a resident of the City and County of San Francisco for a period of at least five years and an elector thereof for a period of at least one year immediately prior to the time for taking such office: That my name is Robert Vanderbilt. My residence address is at No. 120 Ellis Street, San Francisco. My business or occupation is Stock Broker & Investment Counselor.

My qualifications for said office are as follows: My platform is: 1. Slum clearance and rehabilitation programs; 2. Establish a special commission to study and correct Juvenile delinquency; 3. Expedite a rapid transit system for the Bay Area; 4. Establish a Borough System for San Francisco City and County to embrace adjoining communities and cities to correspond to the Borough system of New York City; 5. Increased aid for senior citizens and the disabled; 6. To establish a super plan to attract more conventions to S. F.; 7. Start working now for future World Fairs.

Pursuant to the provisions of Section 175 of Charter of said City and County, I desire that the following designation "Stock Broker" be placed immediately under my name as it will appear on all ballots at the General Municipal Election to be held November 7, 1961.

Signature of Candidate: ROBERT VANDERBILT.

Subscribed before me and filed this 8th day of September, 1961.

CHAS. A. ROGERS,
Registrar of Voters.
By HAROLD J. O'DONNELL,
Deputy Registrar of Voters.

The sponsors for Robert Vanderbilt are:

J. Charles Bannon, 120 Ellis St.; Storekeeper.
Kendall L. Bavett, 1580 Grove St.; Industrial Police Officer.
Ida Mae Butler, 120 Ellis St.; Retired.
Evelyn J. Cooper, 120 Ellis St.; Telephone Operator.
Walter John Graepp, 120 Ellis St.; Doorman St. Francis Theatre S.F.
Ralph Holzman, 140 Ellis St.; Clerk.
Billie Ennis Maxwell, 120 Ellis St.; Hotel Manager.
Bernice Reed, 120 Ellis St.; Import—Export Traffic Clerk.
Gloria Shannon, 120 Ellis St.; Housewife.
Alice Swenson, 120 Ellis St.; Vice President of Hotel Corp.
Marjorie M. Van Valkenburgh, 120 Ellis St. Hotel Pasadena; Cashier.
John Maurice Vickery, 1040 Folsom St. #44; Telephone Salesman.
Mihran Yardumian, 120 Ellis St.; Retired.
Michael T. Zivic, 3330 Scott St.; Merchandising Store.

For Supervisor
CHARLES D. WALKER

I hereby declare myself a candidate for the office of Supervisor for the City and County of San Francisco, State of California, to be voted for at the General Municipal Election to be held in the said City and County on November 7, 1961, and declare the following to be true:

That I shall have been a resident of the City and County of San Francisco for a period of at least five years and an elector thereof for a period of at least one year immediately prior to the time for taking such office: That my name is Charles D. Walker. My residence address is at No. 850 Powell Street, San Francisco. My business or occupation is Business Executive.

My qualifications for said office are as follows: I am a property owner, married, reared and educated in San Francisco thereby thoroughly conversant with civic problems. I own and operate the largest Louver Shutter and Door business in the West. My candidacy is inspired by a determination to protect San Francisco Water Resources from State encroachment. Mindful of the inadequacy of Bus and Trolley Service I pledge remedy efforts. I will apply my successful experience in building my business to making an even greater San Francisco but my actions will always be tempered by consideration for the Taxpayers. I accept the mandate that Supervisors are elected to actually supervise and will conduct myself accordingly.

Pursuant to the provisions of Section 175 of Charter of said City and County, I desire that the following designation "Business Executive" be placed immediately under my name as it will appear on all ballots at the General Municipal Election to be held November 7, 1961.

Signature of Candidate: CHARLES D. WALKER.

Subscribed before me and filed this 14th day of September, 1961.

CHAS. A. ROGERS,
Registrar of Voters.

By P. LEMONE,
Deputy Registrar of Voters.

The sponsors for Charles D. Walker are:

Mrs. Maria Walker, 850 Powell St.; Housewife.
Ernest J. Barry, 2207-43rd Ave.; Office Manager.
Alfred P. Baylacq, 611-34th Ave.; Insurance Broker.
Grace G. Denton, 2458-41st Ave.; Housewife.
Mildred Ann Fogarty, 646-19th Ave.; Housewife.
Mrs. Celia Hahn, 122 Farallones St.; Saleslady.
Robert E. Halsing, 541 Darien Way; Attorney at Law.
Louise L. Hickman, 75 Maddux Ave.; Housewife.
Charles P. Hickman, 75 Maddux Ave.; Mechanic.
Thomas C. Jones, 470 Munich St.; Manufacturers Representative.
A. W. Larrison, 1853 Church St.; Manager.
Frank P. Meagher, 2151-16th Ave.; Painter & Musician.
Lester Z. Nicholson, 555 Magellan Ave.; Stock Broker.
Gabriel Salomon, 257 Cumberland St.; Insurance Broker.
Margaret M. Schluer, 540 Junipero Serra Blvd.; Secretary.
Schurley E. Schluer, Jr.; 540 Junipero Serra Blvd.; Sales Manager.
Celestine M. Swanson, 911 Silver Ave.; Homemaker-Teacher.
Cora Leigh Wilson, 39 Northridge Rd. Bldg. 17; Beautician.
Ethel Wilson, 71 Maddux Ave.; Domestic Work.

For Supervisor
DINA FRANCHI ZICKEL

I hereby declare myself a candidate for the office of Supervisor for the City and County of San Francisco, State of California, to be voted for at the General Municipal Election to be held in the said City and County on November 7, 1961, and declare the following to be true:

That I shall have been a resident of the City and County of San Francisco for a period of at least five years and an elector thereof for a period of at least one year immediately prior to the time for taking such office: That my name is Dina Franchi Zickel. My residence address is at No. 6222-3rd Street, San Francisco. My business or occupation is Real Estate, active building constructor.

My qualifications for said office are as follows: Real estate investor, active in building construction, anxious to secure better government, to improve conditions in City and County of San Francisco and in Laguna Honda Home.

Pursuant to the provisions of Section 175 of Charter of said City and County, I desire that the following designation "Building Constructor" be placed immediately under my name as it will appear on all ballots at the General Municipal Election to be held November 7, 1961.

Signature of Candidate: DINA FRANCHI ZICKEL.

Subscribed before me and filed this 22nd day of September, 1961.

CHAS. A. ROGERS,
Registrar of Voters.
By KENNETH J. LONG,
Deputy Registrar of Voters.

The sponsors for Dina Franchi Zickel are:

Paul Aglietti, 205 Steiner St.; Exporter.
Gertrude Barnett, 1515 Broadway; Property Owner.
Emilio Frassati, 2300 Francisco St.; Insurance Broker.
John M. Goncalves, 2866 Pine St.; Gardener.
Randolph N. Howard, 6297-3rd St.; Musician.
Henry Jonas, 106 Clement St.; Attorney at Law.
Don Lastreto, M.D., 96 Miraloma Drive; M.D.
Hattie Lindow, 2733 California St.; Housewife.
Joseph Pellini, 250 Lisbon St.; Retired.
Marion Rosetta, 1607 Jones St.; Assoc. Editor, Bank of America.

For City Attorney
THOMAS M. O'CONNOR

I hereby declare myself a candidate for the office of City Attorney for the City and County of San Francisco, State of California, to be voted for at the General Municipal Election to be held in the said City and County on November 7, 1961, and declare the following to be true:

That I shall have been a resident of the City and County of San Francisco for a period of at least five years and an elector thereof for a period of at least one year immediately prior to the time for taking such office: That my name is Thomas M. O'Connor. My residence address is at No. 250 Magellan Avenue, San Francisco. My business or occupation is Attorney-at-Law.

My qualifications for said office are as follows: Having served for 14 years as Deputy City Attorney and as Chief Public Utilities Counsel since 1953, I am thoroughly versed in the specialized field of municipal law. I believe that the City Attorney's Office, which represents the interests of all San Franciscans in the complex legal problems surrounding the operations of Hetch Hetchy, the Municipal Railway, the International Airport, the Water Department and the various other City Departments, Boards and Commissions, must be kept free of political pressures, and I pledge my vigorous support of the independent status of the Office as provided for in the Charter of the City and County of San Francisco.

Pursuant to the provisions of Section 175 of Charter of said City and County, I desire that the following designation "Attorney-at-Law" be placed immediately under my name as it will appear on all ballots at the General Municipal Election to be held November 7, 1961.

Signature of Candidate: THOMAS M. O'CONNOR.

Subscribed before me and filed this 11th day of September, 1961.

CHAS. A. ROGERS,
Registrar of Voters.

The sponsors for Thomas M. O'Connor are:

Mrs. Byron Arnold, 2930-21st Ave.; Housewife.
Harold A. Berliner, 10 Crown Terrace; Manufacturer.
John F. Brady, 1296-36th Ave.; Associate Superintendent Schools (Retired).
Dr. Arthur H. Coleman, M.D., 698 Los Pamos Drive; Physician.
Mrs. Charles A. Ertola, 775 Francisco St.; Homemaker.
Vincent F. Finigan, 2121 Broadway St.; Real Estate Broker.
Timothy I. Fitzpatrick, 2677 Larkin St.; Judge of Superior Court.
George Hardy, 1653-16th Ave.; President Building Service Employees Union.
Dion R. Holm, 2090 Pacific Ave.; City Attorney.
William D. Kilduff, 3333 Jackson St.; Investment Broker.
Chang W. Lee, 1512 Jones St.; Dentist.
Bert W. Levit, 901 California St.; Lawyer.
Mrs. Thomas C. Lynch, 98 Clarendon Blvd.; Housewife.
Cyril Magnin, 950 Mason St.; Merchant.
E. O. Midyett, 410 Pierce St.; Member Advisory Committee, National Council of Senior Citizens.
William Moskovitz, 1901 California St.; Real Estate Investments.
Eugene M. Prince, 3421 Pacific Ave.; Attorney (Past President State Bar).
Albert Samuels, 1880 Jackson St.; Jeweler.
Thos. A. Toomey, 635 Quintara St.; Retired, Registrar of Voters.
Stephen A. Zellerbach, 24 Presidio Terrace; Businessman.

For City Attorney

J. JOSEPH SULLIVAN

I hereby declare myself a candidate for the office of City Attorney for the City and County of San Francisco, State of California, to be voted for at the General Municipal Election to be held in the said City and County on November 7, 1961, and declare the following to be true:

That I shall have been a resident of the City and County of San Francisco for a period of at least five years and an elector thereof for a period of at least one year immediately prior to the time for taking such office: That my name is J. Joseph Sullivan. My residence address is at No. 314 San Leandro Way, San Francisco. My business or occupation is Attorney-at-Law.

My qualifications for said office are as follows: I submit my candidacy on my record of experience and accomplishments as a public official for many years, and a practicing attorney since 1934. I was admitted to practice before the United States Supreme Court in 1940. The city positions I have held have given me thorough knowledge of public law and the opportunity to study the operations of the City Attorney's office. I believe I am qualified to institute new administrative procedures in that office which will save taxes and improve the quality of legal service needed by our growing city. I am a World War II veteran.

Pursuant to the provisions of Section 175 of Charter of said City and County, I desire that the following designation "Member of Board of Supervisors" be placed immediately under my name as it will appear on all ballots at the General Municipal Election to be held November 7, 1961.

Signature of Candidate: J. JOSEPH SULLIVAN.

Subscribed before me and filed this 14th day of September, 1961.

CHAS. A. ROGERS,
Registrar of Voters.

The sponsors for J. Joseph Sullivan are:

Mrs. J. Joseph Sullivan, 314 San Leandro Way; Housewife.
John H. Swanson, 3140 Mission St.; Bowling Owner.
William Jack Chow, 550 Montgomery St.; Attorney at Law.
George Liebermann, 2863 Green St.; Attorney at Law.
Thomas P. White, 411 Panorama Drive; Labor Union Official.
Roger D. Lapham, Jr., 2233 Lyon St.; Insurance Broker.
Harry J. Lawlor, 669-29th Ave.; Purchasing Agent.
Jesse C. Colman, 1275 Greenwich St.; Director Citizens Federal Savings & Loan Assn.
Molly H. Minudri, 2201 Pacific Ave.; Attorney at Law.
A. F. Dérre', 170 San Fernando Way; Banker.
Morris Lowenthal, 850 Rockdale Drive; Attorney at Law.
Mrs. Stephen Walter, 2504 Leavenworth St.; Publicist.
John Diestel, 500 Hyde St.; Retired.
Julia G. Porter, 142-27th Ave.; Housewife.
Don Fazackerley, 170 El Verano Way; Publisher.
Samuel A. Ladar, 1918 Vallejo St.; Lawyer.
Mrs. Aaron G. Scott, 1275 Hayes St.; Homemaker—Part Time Interviewer.
Victor S. Abe, 725-19th Ave.; Attorney.
Catherine Prat, 1422 Dolores St.; Housewife.

For Treasurer

JOHN J. GOODWIN

I hereby declare myself a candidate for the office of Treasurer for the City and County of San Francisco, State of California, to be voted for at the General Municipal Election to be held in the said City and County on November 7, 1961, and declare the following to be true:

That I shall have been a resident of the City and County of San Francisco for a period of at least five years and an elector thereof for a period of at least one year immediately prior to the time for taking such office: That my name is John J. Goodwin. My residence address is at No. 426 Jersey Street, San Francisco. My business or occupation is Treasurer, City and County of San Francisco.

My qualifications for said office are as follows: I am thoroughly familiar with all departments of the office of City and County Treasurer, having entered the department as a clerk, and through successful passage of civil service examinations, achieved the position of Chief Deputy Treasurer. During my incumbency as Treasurer, the office has been on a self-supporting basis, requiring no support from taxes. If retained I shall continue to devote my efforts to the maintenance of an efficient and well operated office.

Pursuant to the provisions of Section 175 of Charter of said City and County, I desire that the following designation "Incumbent" be placed immediately under my name as it will appear on all ballots at the General Municipal Election to be held November 7, 1961.

Signature of Candidate: JOHN J. GOODWIN.

Subscribed before me and filed this 13th day of September, 1961.

CHAS. A. ROGERS,
Registrar of Voters.
By HAROLD J. O'DONNELL,
Deputy Registrar of Voters.

The sponsors for John J. Goodwin are:

Mrs. Ethel M. Goodwin, 426 Jersey St.; Housewife.
Harold A. Berliner, 10 Crown Terrace; Manufacturer.
Daniel F. Del Carlo, 50 Chumasero Drive; Labor Representative.
Mrs. Ann S. Dippel, 1280 Lombard St.; Civic Betterment Participations.
Armond DeMartini, 110-32nd Ave.; Educator.
Elizabeth R. Kelley, 656 O'Farrell St.; Business Agent Waitresses Union Local 48.
Thomas A. Maloney, 350 Missouri St.; Insurance Broker.
Eugene H. O'Donnell, 625 San Jose Ave.; Probate Commissioner.
Jos. P. Osterloh, 1137 Diamond St.; Retired.
Joseph S. Quan, 574-18th Ave.; Travel Agent.
Joseph F. Rae, 385 Church St.; Printer & Publisher.
Richard G. Raffetto, 2860 Pierce St.; Insurance Broker.
Michael Riordan, 1501-6th Ave.; Dairy Enterprises.
John N. Rosekrans, 3035 Pacific Ave.; Executive.
Walter H. Sandford, 1330 Baker St.; Trans Bay Federal Savings & Loan Executive.
J. F. Sullivan, Jr., 864 Francisco St.; Banker.
Benjamin H. Swig, 950 Mason St.; Hotel Operator.
C. F. Wentz, 60 Normandie Terrace; Retired.

LEON H. SORELL

I hereby declare myself a candidate for the office of Judge of the Municipal Court, Office No. 1, for the City and County of San Francisco, State of California, to be voted for at the General Municipal Election to be held in the said City and County on November 7, 1961, and declare the following to be true:

That I shall have been a resident of the City and County of San Francisco for a period of at least five years and an elector thereof for a period of at least one year immediately prior to the time for taking such office: That my name is Leon H. Sorell: My residence address is at No. 2050-31st Avenue, San Francisco. My business or occupation is Attorney-at-Law.

My qualifications for said office are as follows: Experience in the general practice of law, by continuous engagement therein from June, 1949, to the present time, in San Francisco, as an active member of The State Bar of California.

Pursuant to the provisions of Section 175 of Charter of said City and County, I desire that the following designation "Attorney-at-Law" be placed immediately under my name as it will appear on all ballots at the General Municipal Election to be held November 7, 1961.

Signature of Candidate: LEON H. SORELL.

Subscribed before me and filed this 12th day of September, 1961.

CHAS. A. ROGERS,
Registrar of Voters.
By P. LEMONE,
Deputy Registrar of Voters.

The sponsors for Leon H. Sorell are:

Arthur E. Lindborg, 3089-21st Avenue; retired, U. S. Army.
Francis J. Hayes, 1167 Cayuga Ave.; Printer.
(Mrs.) Beatrice Avery, 50 Chumasero Drive; Christian Science Practitioner.
Harry G. Clarke, 58-B Alvarado St.; Machinist.
Stephen M. Kovacik, 730 Moscow St.; General Contractor—(Retired).
Margaret A. Ponig, 439 Arch St.; Office Clerk.
John J. Davids, 2580 Polk St.; Claims Representative.
Paul Lowy, 57 Taylor St.; Machinist.
Lorimer D. Allen, 171 Liberty St.; Insurance Broker.
Edmund E. Castel, 531 Miramar Ave.; Public Accountant.
Halland P. Hodges, 3280-17th St.; Machinist.
Richard M. Uuereb, 1542 Howard St.; Machinist-journeyman.
D. J. Senese, 855 Waller St.; Inventory Specialist.
Clair S. Fitzgerald, 2328 Rivera St.; Driver Salesman.
Raymond C. Hansen, 2290-48th Ave., Tool Engineer & Machinist.
Charles Klemme, 591 Dolores St.; Machinist.
Fred Cowell, 1191 Oak St.; Butler—Cook.
Bernice Davids, 22 Dorland St.; Housewife.
Roy M. Bell, 226 Coleridge St.; Machinist.
Clifton R. Guimp, 293 Thrift St.; Machinist.

For Judge of the Municipal Court, Office No. 1

LENORE D. UNDERWOOD

I hereby declare myself a candidate for the office of Judge of the Municipal Court, Office No. 1 for the City and County of San Francisco, State of California, to be voted for at the General Municipal Election to be held in the said City and County on November 7, 1961, and declare the following to be true:

That I shall have been a resident of the City and County of San Francisco for a period of at least five years and an elector thereof for a period of at least one year immediately prior to the time for taking such office: That my name is Lenore D. Underwood. My residence address is at No. 2070 Pacific Avenue, Apt. 701, San Francisco. My business or occupation is Judge, Municipal Court.

My qualifications for said office are as follows: Graduated from Hastings College of the Law, University of California, 1932. Admitted to practice the same year. Private practice until called to serve the State as Deputy Attorney General, 1943. Appointed Judge, Municipal Court 1951. Served in all branches of the Court. Judges of the Municipal Court unanimously elected me Presiding Judge in 1955, which was a tribute to me as a Judge and as a woman. I have tried to understand my fellow man, to be fair and just and be guided by the basic principles of honesty and integrity.

Pursuant to the provisions of Section 175 of Charter of said City and County, I desire that the following designation "Judge, Municipal Court" be placed immediately under my name as it will appear on all ballots at the General Municipal Election to be held November 7, 1961.

Signature of Candidate: LENORE D. UNDERWOOD.

Subscribed before me and filed this 8th day of September, 1961.

CHAS. A. ROGERS,
Registrar of Voters.

The sponsors for Lenore D. Underwood are:

Dr. Peter T. Angel, 1867-15th Ave.; Retired Dentist.
Jefferson A. Beaver, 616 Los Pamos Dr.; Executive.
Harold A. Berliner, 10 Crown Terrace; Manufacturer.
Joseph M. Casey, 610 Polk St.; Supervisor & Labor Relations Consultant.
William J. Chow, 550 Montgomery St.; Attorney at Law.
Eustace V. Cleary, 184 Forest Side Ave.; Retired Teacher.
Mrs. Ann S. Dippel, 1280 Lombard St.; Civic Betterment Participations.
C. A. Ertola, 775 Francisco St.; Dental Surgeon.
William L. Ferdon, 132 Commonwealth Ave.; Attorney at Law.
John P. Figone, Jr., 1046 Union St.; Travel Agent.
Timothy I. Fitzpatrick, 2677 Larkin St.; Judge of Superior Court.
Bernard Goiricelaya, 1866-38th Ave.; Retired.
Ruth Church Gupta, 1910 Green St.; Attorney at Law.
Walter A. Haas, 2100 Pacific Ave.; Manufacturer.
Emmet F. Hagerty, 527 Arch St.; Attorney.
William M. Malone, 1 Gabilan Way; Attorney at Law.
John D. Monaghan, 31 Grand View Ave.; Caterer.
Mrs. John J. Murray, 1306 Portola Drive; Housewife.
Max Sobel, 2127 Broadway; Wholesaler.
Benjamin H. Swig, 950 Mason St.; Hotel Operator.

For Judge of the Municipal Court, Office No. 2

ALBERT A. AXELROD

I hereby declare myself a candidate for the office of Judge of the Municipal Court, Office No. 2 for the City and County of San Francisco, State of California, to be voted for at the General Municipal Election to be held in the said City and County on November 7, 1961, and declare the following to be true:

That I shall have been a resident of the City and County of San Francisco for a period of at least five years and an elector thereof for a period of at least one year immediately prior to the time for taking such office: That my name is Albert A. Axelrod. My residence address is at No. 135 Jordan Avenue, San Francisco. My business or occupation is Judge of the Municipal Court.

My qualifications for said office are as follows: I was born and raised in San Francisco and educated in the San Francisco public schools. I graduated from the University of California and Hastings College of Law; was actively engaged in the practice of law for 32 years. I served as Presiding Judge of the Municipal Court and in every department thereof, both civil and criminal. I served as Pro-tem Superior Judge by appointment of the State Judicial Council. I am married and the father of two children. I have endeavored and will continue to conduct my office with fairness, dignity and equal justice to all, without delays.

Pursuant to the provisions of Section 175 of Charter of said City and County, I desire that the following designation "Judge of the Municipal Court" be placed immediately under my name as it will appear on all ballots at the General Municipal Election to be held November 7, 1961.

Signature of Candidate: ALBERT A. AXELROD.

Subscribed before me and filed this 8th day of September, 1961.

CHAS. A. ROGERS,
Registrar of Voters.
By HAROLD J. O'DONNELL,
Deputy Registrar of Voters.

The sponsors for Albert A. Axelrod are:

Mrs. Albert A. Axelrod, 135 Jordan Ave; Homemaker.
Alan Axelrod, 135 Jordan Ave.; Law Student.
Harold A. Berliner, 10 Crown Terrace; Manufacturer.
Mrs. Rosemary Callahan, 1233 California St.; Housewife.
A. F. Derre', 170 San Fernando Way; Banker.
Philip S. Ehrlich, Fairmont Hotel; Attorney at Law.
John P. Figone, Jr., 1046 Union St.; Travel Agent.
Gus Katsarsky, 401 Lakeshore Dr.; Assistant Sec. of S. F. Labor Council.
Elizabeth R. Kelley, 656 O'Farrell St.; Business Agent for Waitresses Union Loc. 48.
Marshall E. Leahy, 244 Moncada Way; Attorney.
Felix P. Lassalle, 30 San Carlos St.; Florist.
Louis R. Lurie, 2100 Pacific Ave.; Realty Operator & Builder.
Thomas A. Maloney, 350 Missouri St.; Insurance Broker.
Cyril I. Magnin, 950 Mason St.; Merchant.
John D. Monaghan, 31 Grand View Ave.; Caterer.
Benjamin H. Swig, 950 Mason St.; Hotel Operator.
Dr. Henry A. Tagliaferri, 282 Silver Ave.; Oral Surgeon.
Ernest L. West, 165 Marina Blvd.; Salesman.
J. D. Zellerbach, 2790 Broadway St.; Executive.

For Judge of the Municipal Court, Office No. 3

WILLIAM A. O'BRIEN

I hereby declare myself a candidate for the office of Judge of the Municipal Court, Office No. 3 for the City and County of San Francisco, State of California, to be voted for at the General Municipal Election to be held in the said City and County on November 7, 1961, and declare the following to be true:

That I shall have been a resident of the City and County of San Francisco for a period of at least five years and an elector thereof for a period of at least one year immediately prior to the time for taking such office: That my name is William A. O'Brien. My residence address is at No. 27 San Benito Way, San Francisco. My business or occupation is Judge of the Municipal Court.

My qualifications for said office are as follows: Born and educated in San Francisco; University of San Francisco AB. '24; LL.B '26. Admitted to the Bar 1926. Assistant United States Attorney, N. D., Calif. (1927-1932). Member of the faculty University of San Francisco (1926-1934). Thirty years, trial and appellate practice in State and Federal courts. General Counsel, Housing Authority of the City and County of San Francisco (1938-1956). Special Counsel Redevelopment Agency City and County of San Francisco. Appointed Judge of the Municipal Court 1956; Presiding Judge 1959; served Pro Tem Superior Court 1960. Member: Code Commission State of California (1948-1953). Bar Association of San Francisco (member of the Board of Directors 1937-1946). American Bar Association.

Pursuant to the provisions of Section 175 of Charter of said City and County, I desire that the following designation "Judge of the Municipal Court" be placed immediately under my name as it will appear on all ballots at the General Municipal Election to be held November 7, 1961.

Signature of Candidate: WILLIAM A. O'BRIEN.

Subscribed before me and filed this 8th day of September, 1961.

CHAS. A. ROGERS,
Registrar of Voters.

The sponsors for William A. O'Brien are:

Mrs. William A. O'Brien, 27 San Benito Way; Housewife.
Mrs. Sol Silverman, 1310 Jones St.; Housewife.
Eugene D. Bennett, 3320 Baker St.; Attorney at Law.
Harold A. Berliner, 10 Crown Terrace; Manufacturer.
Dr. Arthur M. Coleman, M. D., 698 Los Palomos Drive; Physician.
Daniel J. Collins, 2606-19th Ave.; Stockbroker.
A. F. Derre', 170 San Fernando Way; Banker.
Walter A. Dold, 200 Santa Clara Ave.; Attorney at Law.
Arthur F. Domergue, 2001 Ulloa St.; Funeral Director.
Adrien J. Falk, 1360 Jones St.; Business Advisory.
John P. Figone, Jr., 1046 Union St.; Travel Agent.
Daniel V. Flanagan, 2401 Green St.; Regional Director, AFL-CIO.
Charles J. Foehn, 3473-19th St.; Vice President Int. Bro. of Electrical Workers.
Jack Goldberger, 210 Gellert Drive; Labor Official.
John F. Henning, 185 Westwood Drive; Director, State Dept. of Industrial Relations.
George W. Johns, 19 Devonshire Way; Labor Representative.
Solomon E. Johnson, 435 Bright St.; Attorney at Law.
Gerald J. O'Gara, 2845 Green St.; Attorney at Law.
Henry R. Rolph, 2626 Lyon St.; Attorney at Law.
Dr. Henry A. Tagliaferri, 282 Silver Ave.; Oral Surgeon.

For Judge of the Municipal Court, Office No. 4

ANDREW J. EYMAN

I hereby declare myself a candidate for the office of Judge of the Municipal Court, Office No. 4 for the City and County of San Francisco, State of California, to be voted for at the General Municipal Election to be held in the said City and County on November 7, 1961, and declare the following to be true:

That I shall have been a resident of the City and County of San Francisco for a period of at least five years and an elector thereof for a period of at least one year immediately prior to the time for taking such office: That my name is Andrew J. Eyman. My residence address is at No. 43 Hillcrest Court, San Francisco. My business or occupation is Judge, Municipal Court.

My qualifications for said office are as follows: Married, Father of two. Education: High School, University of Illinois, San Francisco Law School. Former Assistant District Attorney 1944-1947; General Law practice twenty-one years. Overseas War veteran; Past Commander George Washington Post American Legion. Past President Muscular Dystrophy Association; Director Aid to Visually Handicapped. Initiated Nalline program to aid stamping out narcotic addiction. Youthful misdemeanor offenders, instead of jail, given probation to acquire their high school education; others required to help blind people on Saturdays. 1959 received Big Brother Award for San Francisco. Appointed Municipal Judge, February 10, 1959. I solemnly pledge my utmost effort to continue justice with tolerance and understanding for all.

Pursuant to the provisions of Section 175 of Charter of said City and County, I desire that the following designation "Judge, Municipal Court" be placed immediately under my name as it will appear on all ballots at the General Municipal Election to be held November 7, 1961.

Signature of Candidate: ANDREW J. EYMAN.

Subscribed before me and filed this 8th day of September, 1961.

CHAS. A. ROGERS,
Registrar of Voters.

The sponsors for Andrew J. Eyman are:

Mrs. Andrew J. Eyman, 43 Hillcrest Court; Housewife.
Fitz-Gerald Ames, Sr., 80 Estero Ave.; Attorney.
Jefferson A. Beaver, 616 Los Palomos Drive; Executive.
Harold A. Berliner, 10 Crown Terrace; Manufacturer.
Roy P. Cole, 118 Commonwealth Ave.; Chemicals & Raw Materials.
Daniel A. Collins, D.D.S., 2449 Sutter St.; Dentist.
C. A. Ertola, 775 Francisco St.; Dental Surgeon.
James Leo Halley, 20-25th Ave. Nor.; Business Exec.
John J. Haster, 190 Dorantes Ave.; Insurance.
Paul S. Jordan, 2736 Broderick St.; Attorney at Law.
Ben K. Lerer, 520 El Camino Del Mar; Attorney at Law.
Mildred W. Levin, 251 San Anselmo Ave.; Attorney at Law.
Mrs. Thomas C. Lynch, 98 Clarendon Blvd.; Housewife.
Frances M. McAteer, 130 Santa Ana Ave., Housewife.
Joseph C. Orengo, 866 Faxon Ave.; Vice President Cecil Whitebone, Inc.
Harold Stelling, 52 West Clay Pk.; Partner & Gen'l Mgr. Royal Showcase Co.
James E. Stratten, 662-15th Ave.; Exec. Dir. Booker T. Wash. Center.
Dr. Henry A. Tagliaferri, 282 Silver Ave.; Oral Surgeon.
Leo J. Murphy, 21 Loyola Terrace; Banker.
Rose M. White, 306 Delano Ave.; Business Representative.

PROPOSITIONS A, B, C

NOTICE OF FINAL PASSAGE

FILE NO. 156-61-1

ORDINANCE NO. 237-61

CALLING AND PROVIDING FOR A SPECIAL ELECTION TO BE HELD IN THE CITY AND COUNTY OF SAN FRANCISCO ON TUESDAY, NOVEMBER 7, 1961, FOR THE PURPOSE OF SUBMITTING TO THE VOTERS OF THE CITY AND COUNTY OF SAN FRANCISCO PROPOSITIONS TO INCUR BONDED DEBTS OF THE CITY AND COUNTY FOR THE ACQUISITION, CONSTRUCTION AND COMPLETION BY THE CITY AND COUNTY OF SAN FRANCISCO OF THE FOLLOWING MUNICIPAL IMPROVEMENTS, TO WIT: \$115,000,000 MUNICIPAL WATER SYSTEM; \$1,100,000 FORT FUNSTON; \$3,282,000 PUBLIC WELFARE; AND THAT THE ESTIMATED COST TO THE CITY AND COUNTY OF SAID MUNICIPAL IMPROVEMENTS IS AND WILL BE TOO GREAT TO BE PAID OUT OF THE ORDINARY ANNUAL INCOME AND REVENUE OF THE CITY AND COUNTY AND WILL REQUIRE EXPENDITURES GREATER THAN THE AMOUNTS ALLOWED THEREFOR BY THE ANNUAL TAX LEVY; ALL IN ORDER TO DO AND PERFORM ANY AND ALL OF THE MATTERS HEREINABOVE REFERRED TO; FIXING RATE OF INTEREST OF SAID BONDS AND PROVIDING FOR THE LEVY AND COLLECTION OF TAXES TO PAY BOTH PRINCIPAL AND INTEREST THEREOF, PRESCRIBING NOTICE TO BE GIVEN OF SUCH ELECTION AND CONSOLIDATING THE SPECIAL ELECTION WITH THE GENERAL MUNICIPAL ELECTION.

Be it ordained by the People of the City and County of San Francisco:

Section 1. A special election is hereby called and ordered to be held in the City and County of San Francisco on Tuesday, the 7th day of November, 1961, for the purpose of submitting to the electors of said city and county propositions to incur bonded indebtedness of the City and County of San Francisco for the acquisition, construction and completion by the city and county of the hereinafter described municipal improvements in the amounts and for the purposes stated:

(a) MUNICIPAL WATER SYSTEM BONDS, 1961.

\$115,000,000 to pay the cost of the improvement of the municipal water supply system, including water storage, transmission and distribution facilities, pipelines, tunnels, dams, reservoirs, additions to existing reservoirs, pumping plants, planning and designing of all facilities, and enlargement of Don Pedro Dam for storage of water allocated to irrigation districts under the Raker Act to augment the storage capacity of the Hetch Hetchy system, together with lands, easements, rights of way, access roads, pipes, pumps, machinery and all other works, property and structures necessary or convenient therefor;

(b) FORT FUNSTON BONDS, 1961.

\$1,100,000 to pay the cost of approximately 116.394 acres of land, and all structures thereon, constituting part of the property known as Fort Funston in the City and County of San Francisco, title to which is vested in the United States of America, and incidental expenses connected with the acquisition of said property, to be used for recreation and park purposes;

(c) PUBLIC WELFARE BONDS, 1961.

\$3,282,000 to pay the cost of the acquisition of land within the City and County of San Francisco for construction of a building thereon and the necessary equipment of the same, incidental expenses connected with the acquisition of said property, and all other works, properties and structures necessary or convenient thereto, to be used for the conduct and transaction of the business of the Public Welfare Department of the City and County.

Section 2. The estimated costs of the municipal improvements described in Section 1 hereof were fixed by the Board of Supervisors by the following resolutions and in the amounts specified:

Municipal Water Bonds, Resolution No. 291-61, \$115,000,000; Fort Funston Bonds, Resolution No. 438-61, \$1,100,000; Public Welfare Bonds, Resolution No. 478-61, \$3,282,000.

That all of said resolutions were passed by more than two-thirds of the Board of Supervisors and Resolution No. 291-61 approved by the Acting Mayor, and Resolution No. 438-61 and Resolution No. 478-61 approved by the Mayor, and in each of said resolutions it was recited and found that the sums of money specified were too great to be paid out of the ordinary annual income and revenue of the city and county in addition to the other annual expenses thereof or other funds derived from taxes levied for those purposes and will require expenditures greater than the amounts allowed therefor by the annual tax levy.

The method and manner of payment of the estimated costs of the municipal improvements described herein are by the issuance of bonds of the City and County of San Francisco in the principal amounts specified.

Said estimates of cost as set forth in said resolutions, and each thereof, are hereby adopted and determined to be the estimated costs of said improvements, and each thereof.

Section 3. The special election hereby called and ordered to be held shall be held and conducted and the votes thereat received and canvassed, and the returns thereof made and the result thereof ascertained, determined and declared as herein provided and in all particulars not herein recited said election shall be held according to the laws of the State of California providing for and governing elections in the City and County of San Francisco, and the polls for such election shall be and remain open during the time required by said laws.

Section 4. The said special election hereby called shall be and hereby is consolidated with the General Municipal Election to be held Tuesday, November 7, 1961, and the voting precincts, polling places and officers of election for said General Municipal Election be and the same are hereby adopted, established, designated and named, respectively, as the voting precincts, polling places and officers of election for said special election hereby called, and as specifically set forth, in the official publication, by the Registrar of Voters of precincts, polling places and election officers for the said General Municipal Election.

The ballots to be used at said special election shall be the ballots to be used at said General Municipal Election and reference is hereby made to the notice of election setting forth the voting precincts, polling places and officers of election by the Registrar of Voters for the General Municipal Election to be published in the San Francisco Chronicle on or about October 20, 1961.

Section 5. On the ballots to be used at such special election and on the voting machines used at said special election in addition to any other

matter required by law to be printed thereon, shall appear thereon the following, each to be separately stated, and appear upon the ballots as separate propositions:

(a) "Municipal Water System Bonds, 1961. To incur a bonded indebtedness in the sum of \$115,000,000 for the acquisition, construction and completion of transmission and distribution facilities, dams, reservoirs, and all other works, properties and structures for the Municipal Water Supply System improvements."

(b) "Fort Funston Bonds, 1961. To incur a bonded indebtedness in the sum of \$1,100,000 for the acquisition of approximately 116.394 acres of land, constituting part of Fort Funston, all structures thereon, and incidental expenses, for recreation and park purposes."

(c) "Public Welfare Bonds, 1961. To incur a bonded indebtedness in the sum of \$3,282,000 for acquisition of land and construction of a building thereon, and equipment of same for the conduct and transaction of business of the Public Welfare Department."

To vote for any proposition where ballots are used, and to incur the bonded indebtedness to the amount of and for the purposes stated herein, stamp a cross (x) in the blank space to the right of the word "Yes." To vote against any proposition and thereby refuse to authorize the incurring of a bonded indebtedness to the amount of and for the purposes stated herein, stamp a cross (x) in the blank space to the right of the word "No."

Where voting machines are used at said special election said voting machines shall be so arranged that any qualified elector may vote for any proposition by pulling down a lever over the word "Yes" under or near a statement of the proposed proposition appearing on cardboard, paper or other material placed on the front of the machine, and said act shall constitute a vote for the proposition, and by pulling down a lever over the word "No" under or near a statement of the proposed proposition appearing on cardboard, paper or other material placed on the front of the machine, shall constitute a vote against the proposition. Said voting machines and the preparation of the same shall comply in all respects with the provisions of law.

Section 6. If at such special election it shall appear that two-thirds of all the voters voting on said proposition voted in favor of and authorized the incurring of a bonded indebtedness for the purposes set forth in said proposition, then such proposition shall have been accepted by the electors, and bonds shall be issued to defray the cost of the municipal improvements described herein. Such bonds shall be of the form and character known as "serials," and shall bear interest at a rate not to exceed 6 per centum per annum, payable semiannually.

The votes cast for and against each of said respective propositions shall be counted separately and when two-thirds of the qualified electors, voting on any one of such propositions, vote in favor thereof, such proposition shall be deemed adopted.

Section 7. For the purpose of paying the principal and interest on said bonds, the Board of Supervisors shall, at the time of fixing the general tax levy and in the manner for such general tax levy provided, levy and collect annually each year until such bonds are paid, or until there is a sum in the Treasury of said city and county set apart for that purpose to meet all sums coming due for the principal and interest on said bonds, a tax sufficient to pay the annual interest on such bonds as the same become due and also such part of the principal thereof as shall become due before

the proceeds of a tax levied at the time for making the next general tax levy can be made available for the payment of such principal.

Section 8. This ordinance shall be published once a day for at least seven (7) days in the San Francisco Chronicle, a newspaper published daily in the City and County of San Francisco, being the official newspaper of said city and county and such publication shall constitute notice of said election and no other notice of the election hereby called need be given.

Passed for Second Reading—Board of Supervisors, San Francisco, August 14, 1961.

Ayes: Supervisors Casey, Dobbs, Ertola, Ferdon, Halley, McMahon, Sullivan, Tamaras, Tinney.

ROBERT J. DOLAN, Clerk

Read Second Time and Finally Passed—Board of Supervisors, San Francisco, August 21, 1961.

Ayes: Supervisors Blake, Casey, Dobbs, Ertola, Ferdon, Halley, McMahon, Sullivan, Tamaras, Tinney, Zirpoli.

I hereby certify that the foregoing ordinance was finally passed by the Board of Supervisors of the City and County of San Francisco.

ROBERT J. DOLAN, Clerk

Approved August 22, 1961.

GEO. CHRISTOPHER, Mayor

PROPOSITION A

Municipal Water System Bonds, 1961. To incur a bonded indebtedness in the sum of \$115,000,000 for the acquisition, construction and completion of transmission and distribution facilities, dams, reservoirs, and all other works, properties and structures for the Municipal Water Supply System improvements.

ARGUMENT FOR PROPOSITION "A"

To Guarantee San Francisco's Water Future, Vote Yes on Proposition A

The drought for the past three years has created a water shortage that makes the immediate enactment of Proposition "A" an urgent necessity.

San Francisco for years has had one of the finest water systems of any city in the world. It has created and maintained that system independently of any State water system. (The State Water Program you voted on last year had nothing to do with San Francisco.)

San Francisco, as in the past, has to take care of its own water supply and Proposition "A" carries on that tradition of farsightedness and intelligent planning.

And it does it WITHOUT A CENT OF TAXES.

NO TAXES—to expand our pipeline delivery capacity to keep ahead of our needs for the next 25 years.

NO TAXES—to provide water storage in the mountains so that no foreseeable future drought would give us any cause for worry, up to the year 2015.

Not only does it cost nothing in taxes, but makes it possible for San Francisco to reduce its water rates.

There never was a better bargain offered to any community. All it costs you is the time it takes to vote Yes on Proposition "A" this November 7.

Why Proposition "A" Will Cost Nothing

Proposition "A" will cost nothing because the bonds to be issued to construct the pipelines and the dams will be entirely paid for out of the revenue from water and power. This is nothing new—this is the way San Francisco has been paying for its water program right along.

It's the best water program in the State of California. The planning began back in 1901 when steps were first taken to obtain the rights to the Hetch Hetchy water of the Yosemite National Park. Over the years, those rights have been obtained; a water system has been constructed that has served well and faithfully; and from time to time, with the expansion of population, and the increase in the per capita consumption of water, the system has been enlarged and improved.

Proposition "A" is the latest and greatest in a long line of steady intelligent improvements.

How Proposition "A" Insures Our Water Supply

Proposition "A" meets the needs of the San Francisco system in two ways:

1. It expands the system delivery capacity to 305 million gallons a day, or enough to meet all needs until 1985. The present capacity is 180 million gallons, and the present rate of use is 170 million gallons a day. The citizens' group supporting Proposition "A" has prepared a chart that makes this development most vivid. You will find it in the argument prepared by the Water for San Francisco Committee.

2. It more than doubles our capacity to store the excess water of the "wet" years, which would otherwise be wasted. The huge new Don Pedro Dam alone will make available for San Francisco an additional 740,000 acre feet of water as a safeguard against drought years.

This bond issue, because it is self-liquidating, will not require any support from taxes. This is attested by the conclusion of the City Controller, Harry D. Ross: "In my opinion the servicing of the proposed bonded debt will not affect the tax rate of the City and County of San Francisco."

Proposition "A" Has Universal Support

Labor unions, business groups, leaders of both political parties, civic organizations, all three daily newspapers, taxpayers' organizations—all endorse and support Proposition "A."

It deserves your support. It needs your vote—and that of your neighbor. Please be sure that both votes are cast for

YES on Proposition "A."

This argument sponsored by the Public Utilities Commission, Don Fazackerley, President; Henry W. Roden, Vice-President; Stuart N. Greenberg, Commissioner; Thomas P. White, Commissioner; George F. Hansen, Commissioner.

On September 5, 1961, the Board of Supervisors authorized the foregoing argument for inclusion in the election pamphlet for November 7, 1961, by the following vote:

Ayes: Supervisors Blake, Casey, Dobbs, Ertola, Halley, McMahon, Sullivan, Tamaras, Tinney, Zirpoli.

R. J. DOLAN, Clerk

ARGUMENT FOR PROPOSITION "A"

... Vote Yes on Proposition "A" ... It Pays for Itself

The San Franciscan who doesn't vote this Election Day is taking a chance of losing a real bargain.

Fifty-four years of insurance against water shortage—and it doesn't cost a penny in taxes!

An increase in capacity that will make it unnecessary to ration water—and it doesn't cost a penny in taxes.

That's what you get this Election Day if you take the time to vote YES on Proposition "A."

"If it doesn't cost anything in taxes, where will the money come from?" is the natural question.

The answer is simple and clear. Proposition "A" will pay for itself, just as San Francisco's previous water system improvements have paid for themselves right along—from the revenue from the sale of water and power.

Vote Yes on "A"—It Pays Its Way!

Proposition "A" represents an outlay of \$115,000,000. That's a lot of money, but not a penny of it is from taxes. The investment will actually make it possible for the City to reduce water rates.

Here is a graphic forecast of how it is planned to disburse the revenue dollar, averaged over the next 20 years.

THE WATER AND POWER REVENUE DOLLAR
(estimated average use on a 20-year basis)

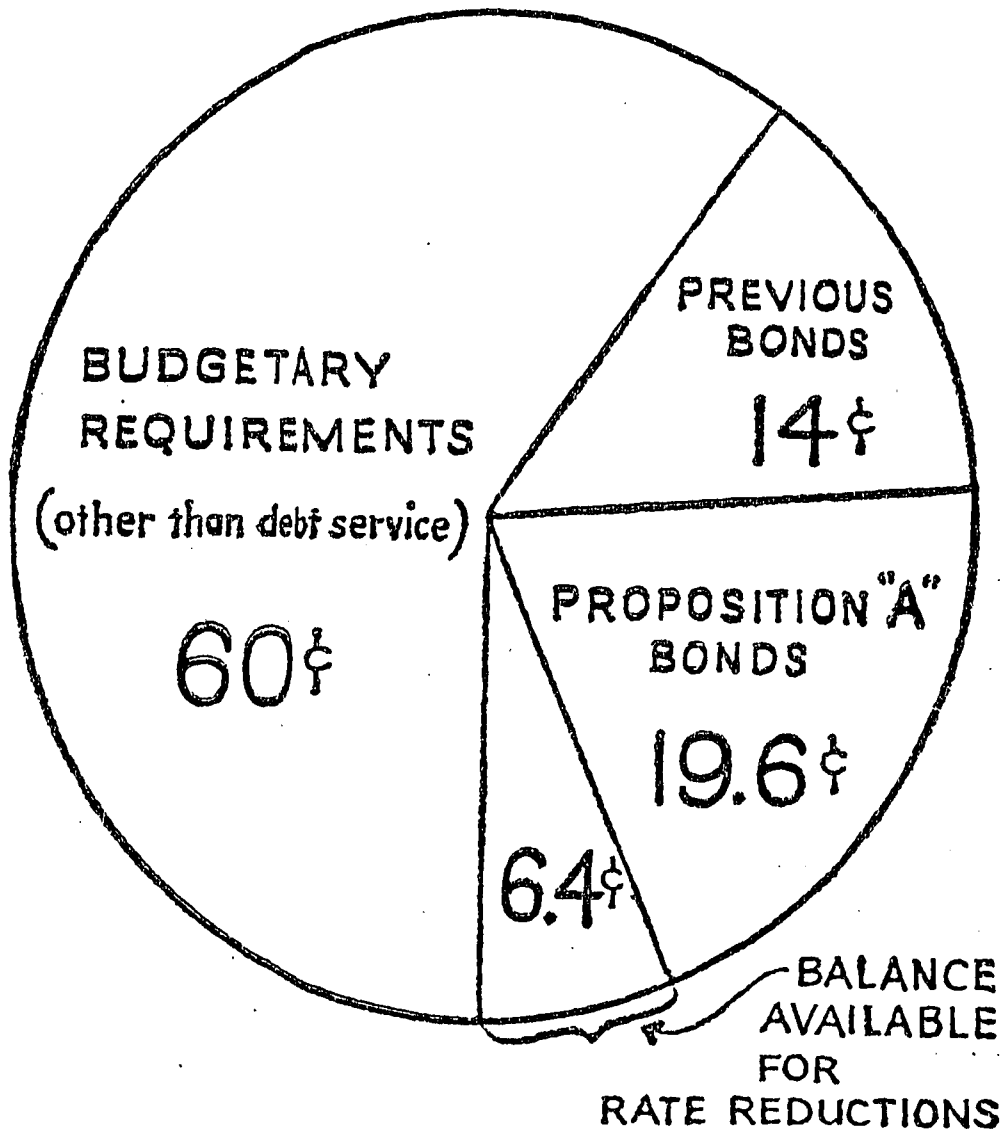

Out of every dollar, about 60 cents will be used to pay the budgetary expense of the system—operating costs, maintenance, wages, reconstruction, main extensions within the city, etc.

Fourteen cents of every dollar would be used to pay off the bonds that already exist, voted for previous expansion needs.

Proposition "A" bonds would cost 19.6 cents of the revenue dollar. The balance, 6.4 cents, is the income available for rate reductions.

These figures were compiled by the careful conservative accounting methods of the City Controller's office. They are based on past and present experience with our water and power system. There's no wishful thinking here—just a clear-headed prediction that Proposition "A" will never require a penny of tax money and will pave the way to a series of rate reductions over the next few years.

Vote Yes! Proposition "A" Is Urgently Needed!

Proposition "A" is designed to equip our San Francisco water system to cope with the threat of drought and water shortage over the next half century.

We've had three successive years of serious drought. Our water reserves are at an all-time low. Proposition "A," by building dams to store water in the mountains (water that would otherwise be wasted), will eliminate any future worry about having enough water, if another series of drought years should occur.

But Proposition "A" also expands our pipeline delivery system to meet our rapidly rising use of water.

This chart shows why we have to expand our pipeline capacity—to bring the water from our great reservoirs in the high Sierra.

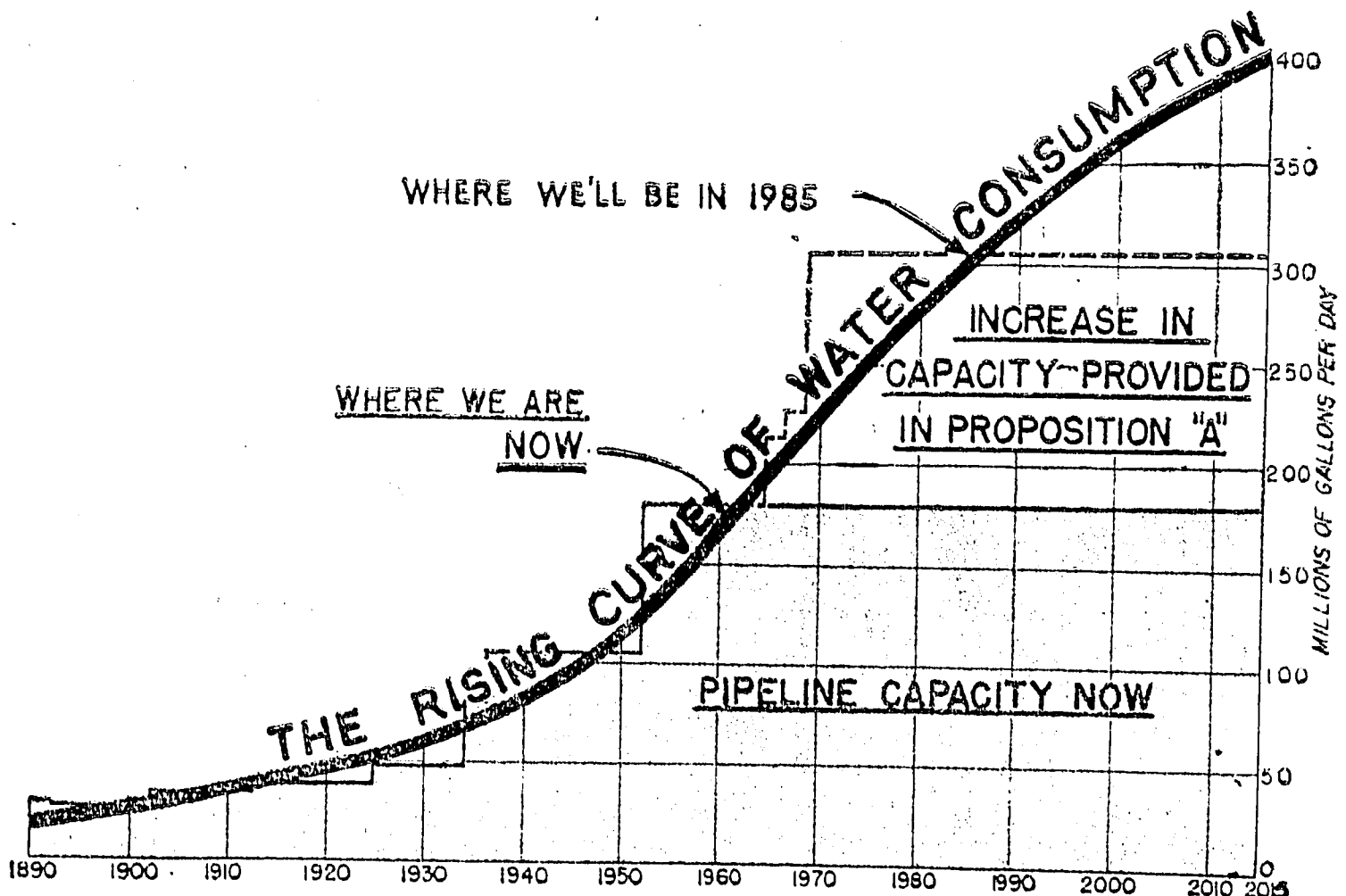

Note that in 1910 we were using about 35 million gallons of water a day. We've risen to a point where we're now using an average of 170 million gallons a day. But note the pipeline capacity—it's at 180 million gallons a day. The curve of consumption is going to pass it, very soon—unless Proposition "A" is passed and construction starts immediately.

Proposition "A" will raise our delivery capacity to 305 million gallons a day. It is expected that we will need that much water by 1985.

Some of the Organizations Backing Proposition "A"

The following organizations are among the many who have voted their endorsement for Proposition "A":

| | |
|---|---|
| The San Francisco Municipal Conference | San Francisco Junior Chamber of Commerce |
| California Northern Hotel Association | San Francisco Real Estate Board |
| Building Owners and Managers Association | San Francisco Labor Council AFL-CIO |
| Apartment House Associations Consolidated, Inc. | San Francisco Building Trades Council |
| Down Town Association | San Francisco Council of District Merchants Associations. |
| San Francisco Chamber of Commerce | |

Not Only You But Your Neighbor, Too—Must Vote "YES" on "A"

Who's against Proposition "A"? Nobody—except the people who don't know how important and urgent it is, and who don't know that it won't cost a penny in taxes.

Who's for it? Everybody! Taxpayers' groups, because it doesn't cost anything; labor organizations, because it will create jobs; home-owners, because a safe and sure water supply insures the value of their homes. Republicans and Democrats alike, because the issue is non-partisan, and advances everybody's welfare. All three daily newspapers and representatives of all nationalities—in short, everyone who wants San Francisco to continue to develop and advance.

But organizations don't vote. Newspapers don't vote. Political parties don't vote. You are the voter. Your vote is needed.

That means, not only You, but your neighbor, too—must vote Yes on A. So be sure you vote on November 7—and be sure your neighbor votes, too!

Vote Yes on Proposition "A"

This argument is sponsored by the Water for San Francisco Campaign Committee.

Joseph Martin, Jr., Chairman
Cyril I. Magnin, Co-Chairman

James A. Folger, Treasurer
Ransom W. Cook, Finance Chairman

On September 18, 1961, the Board of Supervisors authorized the foregoing argument for inclusion in the election pamphlet for November 7, 1961 by the following vote:

Ayes: Supervisors Blake, Casey, Dobbs, Ertola, Ferdon, Halley, McMahon, Sullivan, Tamaras, Tinney.

R. J. DOLAN, Clerk

ARGUMENT FOR PROPOSITION "A"

The San Francisco Municipal Conference endorses Proposition "A" for additional water capacity. The Conference, which devotes itself to the financial aspects of city affairs, considers the water bonds a sound investment for San Francisco's future development. The organizations which make up The Conference request the support of all voters for this vital issue on November 7.

Proposition "A" is planned to be self-supporting from revenues. The controller has reported that the tax rate will be unaffected by these bonds. There is also a possibility of rate reductions by the Public Utilities Commission.

The Conference believes it is urgent that Proposition "A" be approved. Estimates show that demand for water will exceed supply within a few years unless immediate steps are taken to expand the system's capacity.

The Conference and its constituent organizations urge a "Yes" vote on Proposition "A" as an essential step for San Francisco's future.

This argument is sponsored by The San Francisco Municipal Conference,
Victor B. Levit, Chairman

The Conference consists of the following organizations:

| | |
|---|--|
| Apartment House Assns. Consolidated, Inc. | San Francisco Chamber of Commerce |
| Building Owners & Managers Assn. | San Francisco Junior Chamber of Commerce |
| California Northern Hotel Assn. | San Francisco Real Estate Board |
| Down Town Assn. | |

On September 5, 1961, the Board of Supervisors authorized the foregoing argument for inclusion in the election pamphlet for November 7, 1961, by the following vote:

Ayes: Supervisors Blake, Casey, Dobbs, Ertola, Halley, McMahon, Sullivan, Tamaras, Tinney, Zirpoli.

R. J. DOLAN, Clerk

CONTROLLER'S STATEMENT PURSUANT TO CHARTER SECTION 183 PROPOSITION "A"

Municipal Water System Bonds, 1961. To incur a bonded indebtedness in the sum of \$115,000,000 for the acquisition, construction and completion of transmission and distribution facilities, dams, reservoirs, and all other works, properties and structures for the municipal water supply system improvements.

Should the proposed \$115,000,000 Municipal Water System Bonds, 1961, be authorized and when all bonds shall have been issued, it is estimated that approximate costs would be as follows:

| | |
|--------------------------------|----------------------|
| Bond redemption | \$115,000,000 |
| Interest requirement | 46,200,000 |
| Total debt service requirement | <u>\$161,200,000</u> |

Based upon the work program submitted by the Public Utilities Commission, the estimated average amount required to pay the interest thereon and redemption thereof would be approximately \$5,758,000 annually for twenty-eight years.

In my opinion, the servicing of the proposed bonded debt will be paid from water and power revenues and will not affect the tax rate of the City and County of San Francisco.

HARRY D. ROSS, Controller
City and County of San Francisco

PROPOSITION B

Fort Funston Bonds, 1961. To incur a bonded indebtedness in the sum of \$1,100,000 for the acquisition of approximately 116.394 acres of land, constituting part of Fort Funston, all structures thereon, and incidental expenses, for recreation and park purposes.

ARGUMENT FOR PROPOSITION "B"

Vote "Yes" on Proposition "B"

For Fort Funston-Land Acquisition

When the Federal General Services Administration declared approximately 116 acres at Fort Funston to be surplus property, the Recreation

and Park Commission recognized that this was the last sizeable area that could be acquired for Recreation and Park purposes and unanimously approved recommending to the Board of Supervisors that a bond issue be submitted to the electorate at the General Election to be held on November 7, 1961.

Vote Yes on Proposition "B"

The purchase price of \$1,100,000 represents 50% of the actual appraised value; therefore, it would seem to be of prime importance to the City and County of San Francisco to take all the necessary steps to assure reservation of the area for public park and recreation purposes.

Vote Yes on Proposition "B"

The purchase of Fort Funston by the City is in no way intended to prevent the State of California from acquiring and developing this area as a State Park, for which the State Park Commission has expressed their desire when funds are available.

VOTE YES ON PROPOSITION "B" because official 1960 census figures indicate that San Francisco has a relatively small area of park land in relation to its population, compared with other major cities.

Vote Yes on Proposition "B"

The wide support that has been given to the project should result in an overwhelming YES vote.

Endorsed by:

Recreation and Park Commission—Walter A. Haas, President
San Francisco City Planning Commission
San Francisco Chamber of Commerce
San Francisco Planning and Urban Renewal Association

On September 5, 1961, the Board of Supervisors authorized the foregoing argument for inclusion in the election pamphlet for November 7, 1961, by the following vote:

Ayes: Supervisors Blake, Casey, Dobbs, Ertola, Sullivan, Tamaras, Tinney, Zirpoli.

Noes: Supervisors Halley, McMahan.

R. J. DOLAN, Clerk

CONTROLLER'S STATEMENT PURSUANT TO CHARTER SECTION 183 PROPOSITION "B"

Fort Funston Bonds, 1961. To incur a bonded indebtedness in the sum of \$1,100,000 for the acquisition of approximately 116.394 acres of land, constituting part of Fort Funston, all structures thereon, and incidental expenses, for recreation and park purposes.

Should the proposed \$1,100,000 Fort Funston Bonds, 1961, be authorized, and when all bonds shall have been issued, and after evaluation of estimated development costs and additional operation and maintenance expenses at current price levels contained in a report submitted by the Recreation-Park department, and using the 1961-1962 assessment roll as the basis for calculating the effect upon the tax rate, in my opinion, the approximate costs and effect on the tax rate would be as follows:

| | |
|--------------------------------|--------------------|
| Bond redemption | \$1,100,000 |
| Interest requirement | 308,000 |
| Total debt service requirement | <u>\$1,408,000</u> |

| | <u>Amount</u> | <u>Cents in Tax Rate</u> |
|--|------------------|--------------------------|
| Average annual debt service requirement for 15 years | \$ 93,866 | 0.633 |
| Additional annual operation and maintenance costs | 49,231 | 0.332 |
| Total | <u>\$143,097</u> | <u>0.965</u> |
| Non-recurring cost attendant to the development of the Fort Funston area | <u>\$244,950</u> | <u>1.652</u> |

HARRY D. ROSS, Controller

PROPOSITION C

Public Welfare Bonds, 1961. To incur a bonded indebtedness in the sum of \$3,282,000 for acquisition of land and construction of a building thereon, and equipment of same for the conduct and transaction of business of the Public Welfare Department.

ARGUMENT FOR PROPOSITION "C"

For Efficient Welfare Operations Vote "Yes" on Proposition "C"

VOTE "YES" ON PROPOSITION "C" to provide one centrally located, accessible building designed for Public Welfare purposes. This will result in greatly increased efficiency, substantial improvement in service to the public, and material savings in operating costs.

The Public Welfare Department serves over 35,000 persons—primarily the aged, disabled, blind and children. They come from all parts of San Francisco to the department's two, widely-separated, inconvenient offices in old, outmoded buildings.

VOTE "YES" ON PROPOSITION "C" and carry out the repeated recommendations of Grand Juries by providing a single, centrally-located, modern and efficient Public Welfare Building to replace these old, worn-out, inadequate and inefficient structures never intended for the purposes for which they are now being used. One was built as the office of the Treasure Island world's fair and the other was built 45 years ago as a juvenile detention home.

Under existing laws it is anticipated that the Federal and State governments will pay to San Francisco, on a refund basis, approximately 45% of the total cost of this building, including bond interest, except for land purchase. It is also anticipated that a further \$400,000 can be realized through sale of the city-owned property occupied by the Public Welfare Department at Bush and Stockton Streets. This property, adjacent to the new Sutter-Stockton Garage, is valuable for commercial use and its sale would return it to the city's tax rolls.

VOTE "YES" ON PROPOSITION "C." It will result in greater efficiency in departmental operations and in service to the public. It will save both time and money.

Endorsed by:

San Francisco Public Welfare Commission:
 Nicholas A. Loumos, President
 Mrs. Margaret R. Murray
 William P. Scott, Jr.
 Frank H. Sloss
 Mrs. Jacqueline Smith
 Sherman P. Duckel, Chief Administrative
 Officer City and County of San
 Francisco
 Charles deYoung Elkus, Chairman
 Citizens' Committee for Welfare
 Building
 James A. Bacigalupi, Jr., Chairman of Board
 Catholic Social Service of San Francisco
 Harold A. Berliner, President
 Hockwald Company
 Rev. Hamilton T. Boswell, Pastor
 Jones Methodist Church
 Mrs. Allan E. Charles

Mrs. Harry S. Curry
 Mortimer Fleishhacker, Jr.
 Lloyd E. Graybiel
 George W. Johns, Secretary-Treasurer
 San Francisco Labor Council
 Charles J. Jung
 A. F. Mailloux, Secretary
 San Francisco Building & Construction
 Trades Council
 Fred H. Merrill, Executive Vice-President
 Fireman's Fund Insurance Company
 Mrs. Joseph A. Moore, Jr.
 Mrs. A. Boyd Puccinelli
 Malcolm S. M. Watts, M.D.
 Mrs. Harold L. Zellerbach
 United Community Fund of San Francisco
 San Francisco Labor Council
 San Francisco Building and
 Construction Trades Council

On September 5, 1961, the Board of Supervisors authorized the foregoing argument for inclusion in the election pamphlet for November 7, 1961, by the following vote:

Ayes: Supervisors Casey, Ertola, Halley, Sullivan, Tamaras, Tinney, Zirpoli.

Noes: Supervisors Blake, Dobbs, McMahon.

R. J. DOLAN, Clerk

**CONTROLLER'S STATEMENT PURSUANT TO CHARTER SECTION 183
 PROPOSITION "C"**

Public Welfare Bonds, 1961. To incur a bonded indebtedness in the sum of \$3,282,000 for acquisition of land and construction of a building thereon, and equipment of same for the conduct and transaction of business of the Public Welfare Department.

Should the proposed \$3,282,000 Public Welfare Bonds, 1961, be authorized, and when all bonds shall have been issued, and after evaluation of estimated additional operation and maintenance expenses at current price levels as contained in reports submitted by the Department of Public Works and the Public Welfare Department, and using the 1961-1962 assessment roll as the basis for calculating the effect upon the tax rate, in my opinion, the approximate costs and effect on the tax rate would be as follows:

| | |
|--------------------------------|--------------------|
| Bond redemption | \$3,282,000 |
| Interest requirement | 918,960 |
| Total debt service requirement | <u>\$4,200,960</u> |

| | <u>Amount</u> | <u>Cents in Tax Rate</u> |
|--|------------------|------------------------------|
| Average annual debt service requirement for 15 years | \$280,064 | 1.889 |
| Additional annual operation and maintenance costs | \$15,468 | |
| Less Federal and State funds at 45% | <u>6,961</u> | <u>0,057</u> |
| Total | <u>\$288,571</u> | <u>1.946</u> |

The provisions of existing law indicate that, subject to availability of funds, a portion (estimated by the Department of Public Welfare at \$1,648,500) of the construction costs of the proposed building may be paid to the City and County of San Francisco by the State and Federal governments.

The present plan of the Public Welfare Department is to offer for sale the existing Welfare Building at 585 Bush Street upon completion of the proposed building. The Real Estate Department has advised that its current preliminary appraisal of the Bush Street property is \$400,000.

HARRY D. ROSS, Controller,
City and County of San Francisco

PROPOSITION D

Amends Charter Section 59. Requires that the appointment of the Chief Administrative Officer be subject to confirmation and approval of the Board of Supervisors.

CHARTER AMENDMENT

Describing and setting forth a proposal to the qualified electors of the City and County of San Francisco to amend the Charter of said city and county by amending Section 59 thereof to provide that the appointment of the Chief Administrative Officer shall be subject to confirmation and approval by the Board of Supervisors and to delete obsolete provisions in the section.

The Board of Supervisors of the City and County of San Francisco hereby submits to the qualified electors of said city and county at an election to be held therein on November 7, 1961, a proposal to amend the charter of said city and county by amending Section 59 thereof so that the same shall read as follows:

NOTE: Additions or substitutions are indicated by bold face type; deletions are indicated by ((double parentheses)).

Chief Administrative Officer

Section 59. The mayor shall appoint a **qualified person** as chief administrative officer ((a qualified person who)), **subject to confirmation and approval by the board of supervisors.** The appointee shall have been a resident of the State of California for at least five years immediately preceding his appointment. The requisite qualifications of such appointee shall be administrative and executive ability and experience for the position to be filled. ((The first such appointment shall be made immediately after twelve o'clock noon on the 8th day of January, 1932. He shall be paid an annual salary of twelve thousand dollars (\$12,000).))

He shall be subject to suspension and removal in the same manner as elective officers. He shall also be subject to removal by a vote of not less than two-thirds of the board of supervisors, on the basis of written charges, and, if he so requests, only after a public hearing on such charges before the board of supervisors not less than five days nor more than fifteen days after the filing thereof, and prior to the date on which the supervisors shall vote on the question of his removal, but on the filing of written charges, and pending and during such hearing, the supervisors, by majority vote, may suspend him from office. The written charges and any reply thereto by the chief

administrative officer shall be entered at length in the journal of the board of supervisors. The action of the board of supervisors in removing the chief administrative officer shall be final.

Ordered Submitted—Board of Supervisors, San Francisco, June 5, 1961.

Ayes: Supervisors Casey, Dobbs, Ertola, Ferdon, McMahon, Tamaras, Tinney, Zirpoli.

Noes: Supervisors Blake, Halley, Sullivan.

I hereby certify that the foregoing charter amendment was ordered submitted by the Board of Supervisors of the City and County of San Francisco.

ROBERT J. DOLAN, Clerk

ARGUMENT FOR PROPOSITION "D"

Appointment of the chief administrative officer is a responsibility of such importance that it should not be delegated to one man alone. The charter at present states the mayor shall appoint a chief administrative officer. This amendment would add the words "subject to confirmation and approval by the board of supervisors." The appointment of the controller, an equally important officer, has always been subject to approval by the board of supervisors.

The chief administrative officer has jurisdiction and appointive power over many of the thirty-two boards, commissions, and departments in the city. His term of office is limited only by retirement or resignation; or by removal for official misconduct or moral turpitude; or by a two-thirds vote of the board of supervisors. Thus, he will normally be in office through several administrations of elective officials.

This amendment in no way changes the duties of the chief administrative officer. It does divide the responsibility for his appointment between the mayor and the board of supervisors, all chosen by the voters.

For a more representative city government

Vote Yes on Proposition "D"

Sponsored by:

The League of Women Voters of San Francisco

On August 28, 1961, the Board of Supervisors authorized the foregoing argument for inclusion in the election pamphlet for November 7, 1961, by the following vote:

Ayes: Supervisors Casey, Dobbs, Ertola, McMahon, Tamaras, Tinney, Zirpoli.

Noes: Supervisors Blake, Halley.

L. M. SENTER, Acting Clerk

PROPOSITION E

Amends Charter Section 43. Reduces membership of Library Commission from eleven to seven, effective January 8, 1964. Deletes obsolete material.

CHARTER AMENDMENT

Describing and setting forth a proposal to the qualified electors of the City and County of San Francisco to amend the charter of said city and county by amending Section 43 thereof, relating to the Library Department.

The Board of Supervisors of the City and County of San Francisco hereby submits to the qualified electors of said city and county at an election to be held therein on November 7, 1961, a proposal to amend the charter of said city and county by amending Section 43 thereof so that the same shall read as follows:

NOTE: Additions or substitutions are indicated by **bold-face type**; deletions are indicated by ((double parentheses)).

Library Department

Section 43. The library department shall be under the management of a library commission consisting of eleven members who shall be appointed by the mayor and shall serve without compensation.

((The eleven library trustees constituting the board of library trustees in office at the time this charter shall go into effect shall, by lot, classify their respective terms of office so that three of such terms shall begin at twelve o'clock noon on the 15th day of January, 1932, 1933, and 1934, respectively, and two such terms shall begin at twelve o'clock noon on the 15th day of January, 1935.)) The term of each commissioner shall be four years, at the expiration of which the mayor shall appoint his successor.

The library commission shall appoint a librarian and a secretary who shall hold office at its pleasure. The librarian shall be the chief executive of the department and shall be the appointing officer for the department as provided in section 20 of the charter.

((Commencing on the 1st day of January, 1942, all positions in the library department except those of librarian and secretary of the library commission and part time services carrying compensation of less than \$80 per month including valuation of maintenance or other allowances shall be subject to the civil service provisions of this charter, and upon said date, any incumbent of such position in the library department, hereby made subject to civil service, who shall have held such position continuously for one year prior thereto, shall be deemed appointed to such position under the civil service provisions of this charter.))

The library commission shall be the successors in office of the board of library trustees holding office at the time this charter shall go into effect and shall have all the powers and duties thereof, except as in this charter otherwise provided.

Effective January 8, 1964, the library commission shall be reduced in number to seven members; and of the eleven members making up the commission immediately prior to said date, the last seven to have received appointment shall comprise the commission on said date. Notwithstanding any other provision of this section, the term of each of the remaining four members shall on that date automatically terminate.

Ordered Submitted—Board of Supervisors, San Francisco, July 24, 1961.

Ayes: Supervisors Blake, Casey, Dobbs, Ferdon, McMahon, Sullivan, Tamaras, Tinney, Zirpoli.

Noes: Supervisors Ertola, Halley.

I hereby certify that the foregoing charter amendment was ordered submitted by the Board of Supervisors of the City and County of San Francisco.

ROBERT J. DOLAN, Clerk

PROPOSITION F

Amends Charter Section 172.1.11. Provides for City contribution to Health Service System for all administrative expense and to defray additional cost of coverage of retired members. Repeals and rearranges part of section, with no substantial change.

CHARTER AMENDMENT

Describing and setting forth a proposal to the qualified electors of the City and County of San Francisco to amend the charter of said city and county by amending Section 172.1.11 thereto, relating to the Health Service System fund.

The Board of Supervisors of the City and County of San Francisco hereby submits to the qualified electors of said city and county at an election to be held therein on November 7, 1961, a proposal to amend the charter of said city and county by amending Section 172.1.11 thereto, as follows:

NOTE: Additions or substitutions are indicated by bold-face type; deletions are indicated by ((double parentheses)).

Section 172.1.11. There is hereby created a health service system fund. The costs of the health service system shall be borne by the members of the system and retired persons, the City and County of San Francisco because of its members and retired persons and the San Francisco Unified School District because of its members and retired persons. A retired person as used in this paragraph means a former member of the health service system retired under the San Francisco City and County Employees' Retirement System.

The city and county and the school district shall each contribute to the health service system fund ((an amount equal to the amounts contributed thereto by its members and retired persons of the system; provided, however, that for the fiscal year commencing July 1, 1958, such contributions by the city and county and the school district shall be one-fifth (1/5) of the amount contributed thereto by the members of the system; and that for the fiscal year commencing July 1, 1959, such contributions by the city and county and the school district shall be one-half (1/2) of the amount contributed thereto by the members of the system; and that for the fiscal year commencing July 1, 1960, and for each fiscal year thereafter, the contributions by the city and county and the school district shall be equal to the amounts contributed thereto by the members of the system;)) amounts sufficient for the following purposes, and subject to the following limitations:

(a) All funds necessary to efficiently administer the Health Service System;

(b) Matching contributions for the fiscal year commencing July 1, 1962, and each fiscal year thereafter, equal to the amounts contributed thereto by members of the system, provided, however, that the total amount contributed by the city and county and the school district to the health service system fund in each fiscal year, for this purpose, shall not exceed an amount equal to the tax yield that can be produced in each fiscal year by six cents in the tax rate on each one hundred dollars

(\$100.00) valuation of the real and tangible personal property assessed in and subject to taxation by the city and county and the school district.

(c) Monthly contributions required from retired members participating in the system shall be equal to the monthly contributions required from members in the system; provided, however, that for the fiscal year commencing July 1, 1962, and for each fiscal year thereafter, the city and county and the school district shall contribute funds sufficient to defray the difference in cost to the system in providing the same health coverage to retired members as is provided for active employee members thereof.

((Commencing with the fiscal year beginning July 1, 1958, and each fiscal year thereafter the monthly contribution required from retired persons participating in the system shall be equal to the monthly contribution required from members thereof.))

The city and county and the San Francisco Unified School District shall not contribute to the health service system fund any sums, ((including administrative expenses)) except as hereinbefore set forth, on account of participation in the benefits of the system by members' dependents, retired persons' dependents, persons who retired and elected not to receive benefits from San Francisco City and County Employees' Retirement System and resigned employees and teachers defined in section 172.1.6.

It shall be the duty of the board of supervisors and of the board of education annually to appropriate to the health service system fund such amounts as are necessary to cover the obligation of the city and county and of the San Francisco Unified School District hereby imposed. Contributions to the health service system fund of the city and county and of the school district shall be charged against the general fund or the school, utility, bond or other special fund concerned. ((The controller shall transfer to the health service system fund all sums in any other fund now standing to the credit of the health service system.))

Ordered Submitted—Board of Supervisors, San Francisco, August 28, 1961.

Ayes: Supervisors Blake, Casey, Dobbs, Ertola, Halley, Sullivan, Tamaras, Tinney, Zirpoli.

No: Supervisor McMahon.

I hereby certify that the foregoing charter amendment was ordered submitted by the Board of Supervisors of the City and County of San Francisco.

L. M. SENTER, Acting Clerk

ARGUMENT FOR PROPOSITION F

Vote "Yes" on Proposition F

There has been a Health Service System for the benefit of city and county employees for many years. However, in the course of time various inequities have developed. The purpose of this amendment is to wipe out two of these unfair features.

During the last decade employers in private industry have almost universally adopted group insurance plans for the benefit of their employees, and frequently for the dependents of employees as well. In almost every instance, as official surveys show, the full cost of these benefit plans is paid for by the employer.

San Francisco City and County employees, however, pay more than one-half of the cost of their own insurance and 100 percent of the cost for their dependents, and in addition they pay for the administrative costs of running the Health Service System.

The proposed amendment would place the administrative costs of the Health Service System on the City and County, more in line with the general prevailing practice in private industry. City employees will continue to pay more than one-half of the cost of their own insurance.

The second inequity that would be eliminated by the proposed amendment relates to retired persons. Rising costs of medical care for the elderly are a familiar fact. Under the City Charter, the premium paid by a retired employee is fixed at the same amount as the premium for an active young working employee. This means that the additional hospital, medical and surgical expenses incurred by retired persons are being paid for by the active employees. It means that the premiums charged to employees are unfairly loaded. The amendment calls for the City and County to pay the difference between what a retired person actually pays and what it costs the Health Service System to provide the required protection.

In short, the proposed amendment is a step in bringing the Health Service System in line with prevailing practice in the community. City and County employees will still pay more than one-half of the cost for their own insurance and 100 percent of the cost for their dependents. But they will not be saddled with the administrative costs of the system, nor will the active employees be bound to subsidize the greater health costs of retired persons.

Vote Yes on Proposition F

Endorsed by:

Civil Service Association of San Francisco
Civil Service Building Maintenance Union, Local 66A
Municipal Improvement League
San Francisco City and County Employees Union, Local 400
Hospital and Institutional Workers Union, Local 250
Amalgamated Association of Street, Electric Railway
and Motor Coach Employees of America, Division 1380
San Francisco Federation of Municipal Employees, Inc.
Municipal Carmen's Union, Local 250

On August 28, 1961, the Board of Supervisors authorized the foregoing argument for inclusion in the election pamphlet for November 7, 1961, by the following vote:

Ayes: Supervisors Blake Casey, Dobbs, Ertola, Halley, Tamaras, Tinney, Zirpoli.

No: Supervisor McMahan.

L. M. SENTER, Acting Clerk

ARGUMENT AGAINST PROPOSITION "F"

Vote "No" on Proposition "F" More Tax Support for Employees' Health System

Proposition "F" makes two changes in the financial support of the city and county employees' health system. The taxpayers are asked to pay the administrative cost and the extra cost for coverage of retired employees.

These two changes will cost \$616,744 a year on present estimates; as the number of retired employees increases this cost will rise. Some \$596,044 would affect the tax rate, equal to 4.2 cents in your rate.

San Franciscans voted for taxpayer support of the health system in 1957. This was a pioneering move among large government agencies. The state is just beginning financial support for its employees next year. Other large California counties and cities still do not have taxpayer support for health plans.

The charter now provides a limit equal to 6 cents in the tax rate for city support of the health system—this now amounts to \$861,337 a year. Proposition "F" would raise the city subsidy to \$1,478,081 annually—an amount equal to more than 10 cents in the tax rate. These costs would rise with assessment roll increases and larger numbers of retired employees.

The Municipal Conference asks you to vote "NO" on "F" because it makes an excessive demand upon the citizens and taxpayers.

VOTE "NO" ON "F." KEEP THE SIX CENT TAX LIMIT ON THE EMPLOYEES' HEALTH SYSTEM.

This argument is sponsored by the San Francisco Municipal Conference.

VICTOR B. LEVIT, Chairman

The San Francisco Municipal Conference is composed of the following organizations:

Apartment House Associations
Consolidated, Inc.
Building Owners and Managers
Association
Down Town Association

California Northern Hotel Association
San Francisco Chamber of Commerce
San Francisco Junior Chamber of
Commerce
San Francisco Real Estate Board

CONTROLLER'S STATEMENT PURSUANT TO CHARTER SECTION 183 PROPOSITION "F"

Charter Amendment, Amending Section 172.1.11 Relating to the Health Service System Fund.

Should proposition "F" be enacted, in the judgment of this office, which is based on an actuary's report using current Health Service System statistics, the increase in the annual cost of government of the City and County of San Francisco is estimated to be \$616,744.

In my opinion, based on the 1961-1962 assessment roll, \$596,044 of the above annual cost will be financed from ad valorem taxes and is equivalent to four cents (\$0.04) in the tax rate annually.

HARRY D. ROSS, Controller

PROPOSITION G

Adds Section 151.6 to Charter. Authorizes Supervisors to provide for payment of cost of replacement or repair of equipment, property or prostheses of employees lost or damaged in line of duty without fault.

CHARTER AMENDMENT

Describing and setting forth a proposal to the qualified electors of the City and County of San Francisco to amend the charter of said city and county by adding section 151.6 thereto, relating to the replacement or repair of property or prostheses of an officer or employee damaged in the line of duty.

The Board of Supervisors of the City and County of San Francisco hereby submits to the qualified electors of said city and county at an election to be held herein on November 7, 1961, a proposal to amend the charter of said city and county by adding section 151.6 thereto, reading as follows:

Section 151.6. Notwithstanding the provisions of sections 35.5.1, 36.2, 150, 151, 151.3, or any other provision of this charter, the board of supervisors may provide by ordinance for the payment of the costs of replacing or repairing equipment, property, or prostheses of any uniformed officer or employee of the police department, fire department, sheriff's office or municipal railway, such as, but not confined to, eyeglasses, hearing aids, dentures, watches or articles of clothing necessarily worn or carried by such employee when any such items are damaged in the line of duty without fault of the employee. If the items are damaged beyond repair, the actual value of such items may be paid. The value of such items shall be determined as of the time of the damage thereto.

The board by a three-fourths vote of all of its members may make similar provision in relation to any other officer or employee where it finds that the damage or loss was occasioned by unusual circumstances or the occurrence of an extraordinary event.

The board is authorized to enact any and all ordinances necessary to carry out the provisions of this section.

Order Submitted—Board of Supervisors, San Francisco, September 5, 1961.

Ayes: Supervisors Blake, Casey, Dobbs, Ertola, Halley, McMahon, Sullivan, Tamaras, Tinney, Zirpoli.

I hereby certify that the foregoing Charter Amendment was ordered submitted by the Board of Supervisors of the City and County of San Francisco.

ROBERT J. DOLAN, Clerk

CONTROLLER'S STATEMENT PURSUANT TO CHARTER SECTION 183 PROPOSITION "G"

Charter Amendment, Adding Section 151.6 Relating to the Replacement or Repair of Property or Prostheses of an Officer or Employee Damaged in the Line of Duty.

This office could not find a basis for calculating the effect upon the cost of government or the tax rate of the City and County of San Francisco, should proposition "G" be enacted.

HARRY D. ROSS, Controller

PROPOSITION H

Amends Charter Section 154. Provides for method of conducting disciplinary hearings through use of independent hearing officers. Repeals and rearranges other parts of section, making no substantial change.

CHARTER AMENDMENT

Describing and setting forth a proposal to the qualified electors of the City and County of San Francisco to amend the charter of said city and county by amending Section 154 thereof, relating to disciplinary hearings of employees.

The Board of Supervisors of the City and County of San Francisco hereby submits to the qualified electors of said city and county at an election

to be held on November 7, 1961, a proposal to amend the charter of said city and county by amending Section 154 thereof, so that the same shall read as follows:

NOTE: Additions or substitutions are indicated by **bold-face type**; deletions are indicated by ((double parentheses)).

Suspension and Dismissal for Cause

Section 154. No person employed under the civil service provisions of this charter who has completed a probationary period of appointment, exclusive of members of the police and fire departments as provided under section 155, hereof, ((in a position defined by the commission as "permanent")) shall be removed or discharged except for cause, upon written charges, and after an opportunity to be heard in his own defense. The written charges shall specify the grounds for such charges and shall give notification of the time and place where the charges will be heard. Such written charges and notice of hearing may be presented to the accused employee by personal service by the appointing officer or his representative or by mailing such statement to the accused employee's last known address. Pending ((such)) the hearing, the appointing officer may suspend the person so accused ((; but such suspension shall not be valid for more than thirty days, unless hearing upon the charges shall be delayed beyond such time by the act of the accused person. When charges are made, the appointing officer shall, in writing, notify the person accused of the time and place when the charges will be heard, by mailing such statement to his last known address. The appointing officer shall publicly hear and determine the charges, and may exonerate, suspend or dismiss the accused.)) provided that the written charges and notice of hearing must be presented or mailed to the employee within five (5) days of the date of suspension. The appointing officer, with the approval of the civil service commission, may delegate to the head of any utility, institution, bureau, or other subdivision the authority to prepare and to present written charges to an employee under their jurisdiction and to suspend such employee pending hearing on such charges. The hearing shall be held not later than thirty days after the date of notification of charges unless such hearing shall be delayed beyond such time at the request of the accused employee.

The accused employee, unless he desires to waive his right to a hearing on the charges, shall within ten calendar days from date of notification of the charges, file with the appointing officer a written notice of intention to answer the charges.

The civil service commission shall contract for the services of a hearing officer or officers who shall be qualified in accordance with standards to be established by the civil service commission, provided that such hearing officer shall not be an officer or employee of the City and County of San Francisco, and shall assign the hearing officer to hear the charges. The appointing officer may designate a departmental representative to prepare and to present the case to the hearing officer and to represent the appointing officer at the hearing. At the conclusion of the hearing, the hearing officer shall prepare a proposed decision for submission, together with a summary of the evidence presented at the hearing, to the appointing officer. The hearing officer may propose that the employee be exonerated or may propose any of the following penalties: suspension of the employee; reduction in the rate of pay of the employee for a specified temporary period, not to exceed six months and not to exceed one step in the salary range, provided that the rate

of pay may not be reduced below the minimum rate of pay established for such class; reduction in rank of the employee; dismissal of employee.

The appointing officer upon receipt of the proposed decision may adopt it in its entirety, or, if a penalty is proposed, may remit the penalty entirely, or may reduce or increase the proposed penalty and adopt the balance thereof, or may decide the case on the record, with or without taking additional evidence, provided that any penalty assessed by the appointing officer shall be within the limits of the penalties designated above. If the employee is exonerated the appointing officer may, at his discretion, remit the suspension and may order payment of salary to the employee for the time under suspension, and the report of such suspension shall thereupon be expunged from the record of service of such employee. The civil service commission shall immediately be notified of the charges when made, of the hearing, and of the finding thereon. The ((finding)) decision of the appointing officer shall be final, unless within thirty days therefrom the ((dismissed)) employee appeals to the civil service commission. The appeal and all proceedings shall be in writing and shall briefly state the grounds therefor, provided that with the approval of the civil service commission oral argument may be received to supplement such written proceeding. The civil service commission shall examine into the case and may require the appointing officer to furnish a ((record)) transcript of the hearing and may require in writing any additional evidence it deems material, and may, thereupon ((,)) deny the appeal or may reduce or increase the penalty or make such other decision as it deems just. The order or decision of the commission upon such appeal shall be final and shall forthwith be enforced by the appointing officer. If the civil service commission shall reverse or alter the ((finding)) decision of the appointing officer it may, in its discretion, order that the employee affected be paid salary from the time of his discharge or suspension, or may order restoration of salary if the penalty was temporary reduction in rate of pay, or reduction in rank.

The civil service commission may hear and determine any charge filed by a citizen or by the authorized agents of the commission when the appointing officer neglects or refuses to act.

((Removal or discharge)) **Disciplinary action** as stated above may be ((made)) taken for any of the following causes but not limited exclusively thereto: incompetence, habitual intemperence, immoral conduct, insubordination, discourteous treatment of the public, dishonesty, inattention to duties, or engaging in prohibited political activities. The civil service commission shall define such causes as enumerated above by rule, and no act or omission shall constitute cause for disciplinary action unless provided by rule of the civil service commission.

The civil service commission shall enact any and all rules necessary to administer and interpret the provisions of this section. Nothing in this section shall limit or restrict rules adopted by the commission governing layoffs or reduction in force.

The appointing officer may, for disciplinary purposes, suspend a subordinate for a period not exceeding thirty calendar days in any six month period; and suspension shall carry with it the loss of salary for the period of suspension. If, in the opinion of the appointing officer, disciplinary action in addition to thirty days suspension in any six month period is required, then the appointing officer shall proceed in accordance with the provisions of this section for written charges and hearing. The suspended employee shall be notified in writing of the reason for such suspension, and if the suspension be for more than five days but less than sixteen days, the employee

shall, at his request, be given a hearing by the appointing officer. If the suspension be for sixteen days or more, the employee shall at his request be given a hearing before a hearing officer assigned by the civil service commission. The hearing officer shall prepare a summary of the hearing and a proposed recommendation for submission to the appointing officer. The decision of the appointing officer in all cases of suspension for disciplinary purposes shall be final. If after the hearing the appointing officer shall decide that the suspension or any portion of it was not justified, the appointing officer in his discretion may order that the suspension or any portion of it be expunged from the personal records of the employee and that the employee be paid salary for such period of suspension that is so expunged.

The civil service commission shall include in its annual budget or supplemental requests, funds for the employment under contract of hearing officers, and for other expenses directly related thereto, and the mayor shall approve and the board of supervisors shall appropriate sufficient funds for such purpose in accordance with the budgetary and fiscal procedures provided in this charter.

Ordered Submitted: Board of Supervisors, San Francisco, September 5, 1961.

Ayes: Supervisors Blake, Casey, Dobbs, Ertola, Halley, McMahon, Sullivan, Tamaras, Tinney, Zirpoli.

I hereby certify that the foregoing Charter Amendment was ordered submitted by the Board of Supervisors of the City and County of San Francisco.

ROBERT J. DOLAN, Clerk

ARGUMENT FOR PROPOSITION H

Vote "Yes" On Proposition H

This charter amendment has been presented by the Civil Service Commission and has been approved for inclusion on the ballot by the Board of Supervisors. The purpose of the amendment is to correct a procedure now included in the charter which years of experience has proved to be unsatisfactory. This charter amendment will provide for a qualified Hearing Officer, rather than the appointing officer as is now the case, to take evidence and to hear cases of disciplinary action against permanent civil service employees. This amendment would benefit the city in the following respects:

1. It would correct the situation in which the appointing officer, when holding a hearing on disciplinary action of a permanent civil service employee, now acts as accuser, prosecutor, judge and jury.

2. The amendment provides that a hearing will be held by a disinterested, impartial officer trained and qualified to develop the facts in these types of cases, and to recommend equitable action. The Hearing Officer will have the technical knowledge of the laws and rules governing these procedures and will be able to properly evaluate the evidence and to keep out extraneous issues.

3. The appointing officer will still retain authority within the department for disciplinary action, but such action will be based on a proper development of the factual situation.

4. The use of a qualified Hearing Officer will tend to equalize where desirable disciplinary action for similar offenses. This is not the case at the present time.

5. A wider range of penalties is provided for consideration of the appointing officer in imposing disciplinary action. Besides suspension or

dismissal, the proposed amendment would permit consideration of temporary reduction in the rate of pay, or reduction in rank. There are cases in which such disciplinary action would be a more reasonable penalty than suspension or dismissal.

6. The right to appeal to the Civil Service Commission from disciplinary action taken after a hearing remains unchanged. The appeal procedure to the Civil Service Commission is clarified to the extent that the charter amendment would specifically permit an appeal to the Civil Service Commission from a period of suspension assessed by the appointing officer after a hearing held for the purpose of determining whether the employee should be dismissed.

7. The appointing officer still retains final authority for suspension of a subordinate for a period not exceeding thirty days, but in the case of a suspension of more than fifteen days, the employee would have the right to request a hearing before a Hearing Officer. The appointing officer would thus have the benefit of independent review of such cases.

8. The use of a Hearing Officer has been found to be a more satisfactory and desirable procedure in other public agencies.

9. The correction of procedures in disciplinary actions will reflect itself in better working conditions and better morale of city employees. This, in turn, will lead to improved services for the citizenry of San Francisco. Better disciplinary procedures will promote efficiency and economy and result in savings to the taxpayers and others who pay the costs of city and county operations.

10. Savings will result from the fact that the time which appointing officers must now give to hearing disciplinary cases will be transferred to the Hearing Officer whose hourly rate of pay will be substantially less than that of the appointing officer.

This amendment has been endorsed by the San Francisco Federation of Municipal Employees, Inc.; the Executive Board of the San Francisco City and County Employees Union, Local 400, A.F.L.-C.I.O.; the Amalgamated Association of Street, Electric Railway and Motor Coach Employees of America, Division 1380; the San Francisco Municipal Parks Employees Union, Local 311; and the Hospital and Institutional Workers' Union, Local 250.

On September 5, 1961, the Board of Supervisors authorized the foregoing argument for inclusion in the election pamphlet for November 7, 1961, by the following vote:

Ayes: Supervisors Blake, Casey, Dobbs, Ertola, Halley, McMahon, Sullivan, Tamaras, Tinney, Zirpoli.

R. J. DOLAN, Clerk

ARGUMENT AGAINST PROPOSITION "H"

Vote No on Proposition "H"

Voters of San Francisco, reject this proposition! It is an unsound, unworkable scheme, ultimately leading to a complete breakdown of the disciplinary system for employees of the City and County of San Francisco.

Vote No on Proposition "H"

We in San Francisco have good reason to be proud of our Civil Service System, judged by many to be one of the finest in the country. Time and

again, the voters of San Francisco have resisted efforts to impose unsound, unworkable schemes on our system.

Vote No on Proposition "H"

Proposition "H" represents another attempt to impose an unsound scheme on our Civil Service System. Proponents of the scheme claim it is a forward-looking plan, designed to promote efficiency in the city's disciplinary system.

Vote No on Proposition "H"

Nothing could be further from the truth! In recognition of the fact that this proposal is unsound and unworkable, as well as an inefficient means of administering a disciplinary system, top administrative officials of the City and County of San Francisco actively oppose this proposal.

Vote No on Proposition "H"

This measure contains an unknown cost factor. It provides no standards for the selection and contracting of a Hearing Officer. This proposal does not give the Hearing Officer decision-making authority; but only permissive authority to "recommend" disciplinary actions.

Vote No on Proposition "H"

Opposition to this measure has been vigorously voiced by such prominent city officials as the Chief Administrative Officer, Manager of Utilities, Director of Public Works and other officials of our municipal government.

Vote No on Proposition "H"

We also concur with this opposition. Our organization has consistently led the fight to protect our local Merit System. For nearly 60 years we have been in the vanguard of those who would protect and enhance our Merit System.

Vote No on Proposition "H"

We appeal to the voters of San Francisco to once again join with us in defeating this costly, time-wasting measure. By rejecting this unsound scheme, you will mandate the Civil Service Commission to propose in its place, a modern, sound approach to the city's disciplinary system.

Vote No on Proposition "H"

Protect your Merit System! Vote No on Proposition "H"
This argument is sponsored by the Civil Service Association of San Francisco, GRANVILLE DeMERRITT, Executive Secretary.

**CONTROLLER'S STATEMENT PURSUANT TO CHARTER SECTION 183
PROPOSITION "H"**

Charter Amendment, Amending Section 154 Relating To Disciplinary Hearings of Employees.

Should proposition "H" be enacted, in the judgment of this office, which is based on information furnished by the Civil Service Commission, the increase in cost to the City and County of San Francisco is estimated not to exceed \$3,000.00 annually.

Based on the 1961-1962 assessment roll, \$3,000.00 is equivalent to two hundredths of one cent (\$0.0002) in the tax rate.

HARRY D. ROSS, Controller
City and County of San Francisco

DECLARATION OF POLICY

PROPOSITION I

Declaration of Policy. Shall the city and county institute proceedings to acquire the land and improvements commonly known as the Fox Theatre property as a site for musical, cultural, artistic, convention and other public assembly purposes?

The undersigned members of the Board of Supervisors of the City and County of San Francisco hereby submit to the qualified electors of the said City and County, at an election to be held therein, November 7, 1961, the following declaration of policy upon the ballot at said election, so that the electors can express their preference for or against said declaration voting "Yes" or "No" thereon, to wit:

Shall the city and county institute proceedings to acquire the land and improvements commonly known as the Fox Theatre property as a site for musical, cultural, artistic, convention and other public assembly purposes?

JAMES LEO HALLEY
WILLIAM C. BLAKE
JOSEPH M. CASEY
C. A. ERTOLA

ARGUMENT FOR PROPOSITION I

Acquisition of the Fox Theatre Vote Yes On Proposition I

Proposition I enables the purchase of the Fox Theatre property, bounded by Market, Polk, Hayes and Larkin Streets, for convention and other public assembly purposes, at the discretion of the San Francisco Board of Supervisors.

The Fox Theatre, which is located directly across Hayes Street from the Civic Auditorium, is a natural and essential expansion of the City's civic center convention and exhibition plant. The Fox Theatre will provide San Franciscans with a medium-sized public assembly facility urgently needed to make available necessary convention space during the Civic Auditorium remodeling already underway. It moreover fills the need for the medium-sized meeting facility which is becoming more and more important in attracting major conventions and has been adopted by other leading convention cities with which San Francisco must compete.

Vote Yes On Proposition I

San Francisco's thriving convention business, which injects \$37,500,000 annually into our economy, representing according to Federal Reserve Bank estimates more than \$900,000,000 in its annual flow through San Francisco trade channels, threatens to "level off" unless present facilities can be expanded.

Acquiring the Fox Theatre, along with the off-street parking this property provides, will enable San Francisco to increase its lucrative convention business in step with increased number of hotel and motel rooms now being constructed to meet the rising competition from other cities.

The need for a supplementary auditorium at Civic Center has long been recognized. It was confirmed by professional planning specialists, including the Mayor's Technical Coordinating Committee on Civic Center Development. That Committee concurred with the findings of a 1958 survey by the Industrial Planning Associates in recommending that the Fox Theatre be acquired by the City and County as a part of the long-range program of Civic Center Development.

Vote Yes On Proposition I

Reports by the City Engineer, the City Architect and the Superintendent of Building Inspection indicate the building is in good condition. The San Francisco Convention and Visitors Bureau states: "If the Fox Theatre is not purchased at this time, according to Director of Property, Philip Rezos, eventually a new facility of like capacity will be required by the City at a cost of over \$14,000,000 rather than the \$1,050,000 which is the present price of the Fox."

Vote Yes On Proposition I

The Fox Theatre has an unsurpassed location convenient to the theatres, hotels and other convention facilities. Besides helping to fill the void existing during the rehabilitation of the Civic Auditorium it will further help to create new convention business after the Civic Auditorium returns to full operation in 1965.

The use of the Theatre will permit two different conventions to meet simultaneously in the Civic Center, and in freeing the main arena of the Civic Auditorium of meetings, will permit the Civic Auditorium to be used for trade show exhibits and other events necessary to the modern convention while meetings are held in the Fox Theatre.

Acquisition of the Fox Theatre also will fill a need for medium-sized, local cultural, theatrical and other events to supplement convention use when not required for convention purposes, a growing problem now being faced by existing City facilities.

Vote Yes On Proposition I

As a result of the Fox Theatre facility attracting more and larger conventions to San Francisco, the increase of outside money spent in our City by increased numbers of conventioners will add many times the additional income from rentals of the Theatre, to the City's business, industry and payrolls.

Vote Yes On Proposition I

The following, among many others, urge you to vote Yes on Proposition I:

| | |
|--|---|
| San Francisco Chamber of Commerce | San Francisco Building & Construction |
| San Francisco Junior Chamber of Commerce | Trades Council |
| San Francisco Labor Council | Building Owners & Managers' Association |
| Downtown Association of San Francisco | California Northern Hotel Association |
| San Francisco Convention and Visitors Bureau | |

This argument authorized for inclusion in the election pamphlet by the following supervisors:

WILLIAM C. BLAKE, Supervisor,
City and County of San Francisco
JOSEPH M. CASEY, Supervisor,
City and County of San Francisco
CHARLES A. ERTOLA, Supervisor,
City and County of San Francisco
JAMES L. HALLEY, Supervisor,
City and County of San Francisco

ARGUMENT AGAINST PROPOSITION I

Vote NO on the Fox Theater Purchase

The taxpayers of San Francisco are being asked to take the obsolete Fox Theater off its owner's hands. The excuse given is that the theater is needed as a "convention center."

Is it needed? What will it cost?

Read the facts that prove we do not need the Fox Theater.

The sale price has been variously estimated at anywhere from \$750,000 to \$1,750,000. Now it is reported at \$1,100,000.

But that is just the start.

If the city buys the Fox, we taxpayers will lose \$75,000 a year in tax revenues alone.

If the city buys the Fox, we taxpayers will also have to assume more than \$125,000 in annual costs for rehabilitation, watchmen, and other services.

The initial investment gets the foot in the door—THEN, the taxpayers will be obligated for over \$200,000 A YEAR IN COSTS.

What about the need? DON'T BE MISLED! San Francisco has no shortage of meeting space.

Mayor Christopher has said we do not need the Fox Theater, and the mayor is well acquainted with our tourist and convention business requirements.

Don't forget that two years ago we approved a \$7 million bond issue to enlarge and rehabilitate the Civic Auditorium.

Don't forget that we have the Opera House, the Veterans War Memorial Building, the Masonic Temple, and many new convention accommodations in hotels recently built or now building.

Then why this sudden drive to foist the obsolete Fox Theater on to the taxpayers' backs? There are many other theaters available in San Francisco because, like the Fox, they have outlived their usefulness. If we buy the Fox won't we then be asked to buy some of these other outmoded movie palaces on the same pretense?

We agree with Mayor Christopher that the Fox Theater is not needed as a convention center.

The City of San Francisco has many other obligations far more important than taking obsolete structures off the hands of owners who understandably want to dispose of them. We can't afford to play Santa Claus to those owners.

For your own sake as a taxpayer, and as a matter of good business sense,

Vote NO on the Fox Theater Purchase Proposition I

This argument is sponsored by the following members of the Bond Screening Committee:

J. F. SULLIVAN, JR.

BENJ. H. SWIG

JOS. A. MOORE, JR.

GARRET McENERNEY II

22

SAMPLE BALLOT

VOTE EARLY
POLLS OPEN FROM
7 A.M. to 8 P.M.

The Voting Machine Will
Record Votes ONLY Where
The Pointers Are Left
DOWN, Covering names of
Candidates.



DIRECTIONS FOR VOTING



- 1st. MOVE RED HANDLE LEVER of VOTING MACHINE to the RIGHT as far as it will go and LEAVE IT THERE.
- 2nd. TO VOTE FOR CANDIDATES of your choice, pull down the POINTERS over the names of the CANDIDATES for whom you wish to VOTE and LEAVE THEM DOWN.
- 3rd. TO VOTE for a person whose name does not appear on the BALLOT LABEL CARD, raise numbered slide at top of machine corresponding to number of office on OFFICE TITLE CARD, and write name of candidate on paper under slide. (Do not pull down pointer over

name of any
except for the
dates, so that
are entitled to
4th TO VOTE FOR
MEMBERS OF
"NO" as you

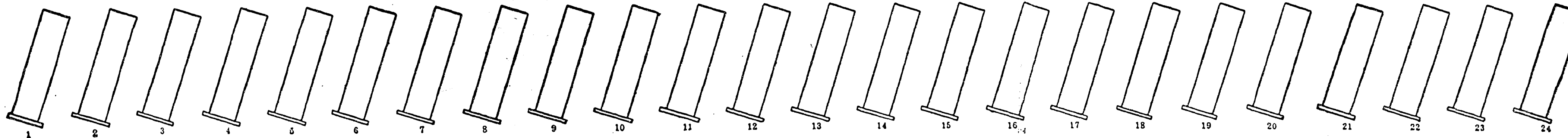

| | | | | | | | | | | | | | | | | | | | | | | | | | | | |
|---|------------|---|-----------|---|------------|--|-----------|---|------------|--|-----------|---|------------|---|-----------|---|------------|---|-----------|---|------------|---|-----------|---|------------|--|-----------|
| | YES | PROPOSITION "A" | NO | | YES | PROPOSITION "B" | NO | | YES | PROPOSITION "C" | NO | | YES | PROPOSITION "D" | NO | | YES | PROPOSITION "E" | NO | | YES | PROPOSITION "F" | NO | | YES | PROPOSITION "G" | NO |
| 1 | | Municipal Water System Bonds, 1961. To incur a bonded indebtedness in the sum of \$115,000,000 for the acquisition, construction and completion of transmission and distribution facilities, dams, reservoirs, and all other works, properties and structures for the Municipal Water Supply System improvements. | 4 | 2 | | Fort Funston Bonds, 1961. To incur a bonded indebtedness in the sum of \$1,100,000 for the acquisition of approximately 116.394 acres of land, constituting part of Fort Funston, all structures thereon, and incidental expenses, for recreation and park purposes. | 6 | 3 | | Public Welfare Bonds, 1961. To incur a bonded indebtedness in the sum of \$3,282,000 for acquisition of land and construction of a building thereon, and equipment of same for the conduct and transaction of business of the Public Welfare Department. | 10 | 4 | | Amends Charter Section 59. Requires that the appointment of the Chief Administrative Officer be subject to confirmation and approval of the Board of Supervisors. | 14 | 5 | | Amends Charter Section 43. Reduces membership of Library Commission from eleven to seven, effective January 8, 1964. Deletes obsolete material. | 18 | 6 | | Amends Charter Section 172.1.11. Provides for City contribution to Health Service System for all administrative expense and to defray additional cost of coverage of retired members. Repeals and rearranges part of section, with no substantial change. | 22 | 7 | | Adds Section 151.6 to Charter. Authorizes Supervisors to provide for payment of cost of replacement or repair of equipment, property or prostheses of employees lost or damaged in line of duty without fault. | 26 |

SUPERVISORS VOTE FOR FIVE

| | | | | | | | | | | | | | | | | | | | | | | | | | | | |
|--------------------------------------|--|--|---------------------------------------|--|--|--|--|------------------------------------|--------------------------------------|---|---------------------------------------|---|--|--|--|---|-------------------------------------|--|--|---|---------------------------------------|---|---|--|--|--|--|
| | | | | | | | | | | | | | | | | | | | | | | | | | | | |
| 1A ALAN H. Nichols Attorney | 2A L. PATRICK (Pat) O'Brien Businessman | 3A THOMAS P. O'Toole Insurance Executive | 4A HAYDEN Perry Lithographer | 5A AL J. Quinn Public Accountant | 6A JOSE JULIO Sarria Entertainer- Host | 7A DONALD J. Sullivan Attorney at Law | 8A JOHN L. Sullivan General Contractor | 9A WARREN Sullivan Lawyer | 10A PETER Tamaras Incumbent | 11A JOSEPH E. Tinney Incumbent | 12A HAROLD Treskunoff Waiter | 13A ROBERT Vanderbilt Stock Broker | 14A CHARLES D. Walker Business Executive | 15A DINA FRANCHI Zickel Building Constructor | 16A JOHN Abraham Painting Contractor | 17A WILLIAM C. Blake Incumbent | 18A ROGER Boas Businessman | 19A ARCHIE Brown Longshoreman | 20A DONALD J. Bruce Public Relations | 21A JIM Coventry Legal Investigator | 22A THOMAS P. Curtin Drayman | 23A A. F. (Gus) Gaynor Insurance | 24A EDWIN J. Greenough Barber, Marriage Order | | | | |

any candidate in office group in which you intend to write in name of a candidate, or the office of Supervisor, in which case after writing in one or more names of candidates, you may pull down such number of pointers over the printed names of candidates that the aggregate will not exceed five, the number of candidates for which you intend to vote.)

FOR OR AGAINST PROPOSITIONS or FOR OR AGAINST CONFIRMATION OF OFFICERS OF BOARD OF EDUCATION, pull DOWN pointers over the words "YES" or "NO" as you may desire to vote and LEAVE THEM DOWN.

5th. LEAVING THE POINTERS DOWN as you have placed them, move the RED HANDLE LEVER of the VOTING MACHINE to the LEFT as far as it will go and you have voted and your vote is registered.

IF IN DOUBT AS TO OPERATING THE VOTING MACHINE, REQUEST INSTRUCTIONS FROM THE INSPECTOR OR JUDGE OF THE ELECTION BOARD BEFORE ATTEMPTING TO VOTE.

GENERAL MUNICIPAL ELECTION

November 7, 1961

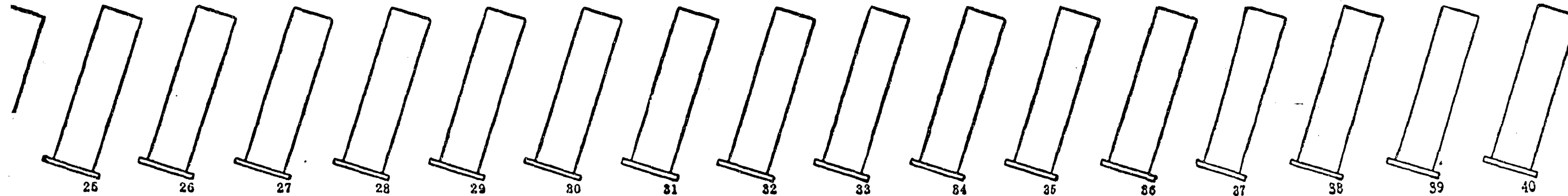

| YES | PROPOSITION "H" | NO | YES | PROPOSITION "I" | NO |
|---|-----------------|----|--|-----------------|----|
| | | | | | |
| Amends Charter Section 154. Provides for method of conducting disciplinary hearings through use of independent hearing officers. Repeals and rearranges other parts of section, making no substantial change. | | | Declaration of Policy. Shall the city and county institute proceedings to acquire the land and improvements commonly known as the Fox Theatre property as a site for musical, cultural, artistic, convention and other public assembly purposes? | | |

CITY AND COUNTY PROPOSITIONS

Vote YES or NO on Each

| 25 | 26 | 27 | 28 | 29 | 30 | 31 | 32 | 33 | 34 | 35 | 36 | 37 | 38 | 39 | 40 | 41 | 42 | 43 | 44 | 45 |
|--------------------------------|--|----------------------------|----------------------------------|--------------------------------------|----------------------------------|-----------------------------------|--|--------------------------------------|---|--|---------------------------------------|--|---------------------------------------|--|---|---|-----------------------------------|--------|------------------------------|--------|
| | | | | | | | | | CITY ATTORNEY | TREASURER | JUDGE OF THE MUNICIPAL COURT Office 1 | Judge of the Municipal Court Office 2 | Judge of the Municipal Court Office 3 | Judge of the Municipal Court Office 4 | MEMBER OF BOARD OF EDUCATION | MEMBER OF BOARD OF EDUCATION | | | | |
| | | | | | | | | | Vote for One | Vote for One | Vote for One | Vote for One | Vote for One | Vote for One | Nominated by Mayor for Confirmation by Electors | Nominated by Mayor for Confirmation by Electors | | | | |
| 25A WARREN Hinckle Businessman | 26A GEORGE W. Johns Labor Representative | 27A W. HARRY Johns Realtor | 28A ROBERT O. Jones Metal Lather | 29A W. H. (Bill) Lammers Coin Dealer | 30A ERNEST Lotti Union Executive | 31A CHARLES Marsalli Restaurateur | 32A JOSEPH JOHN Migliozi Small Businessman | 33A JACK Morrison Newspaper Reporter | 34A I. JOSEPH Sullivan Member of Board of Supervisors | 35A THOMAS M. O'Connor Attorney at Law | 36A JOHN J. Goodwin Incumbent | 37A LENORE D. Underwood Judge, Municipal Court | 38A LEON H. Sorell Attorney at Law | 39A ALBERT A. Axelrod Judge of the Municipal Court | 40A WILLIAM A. O'Brien Judge of the Municipal Court | 41A ANDREW J. Eyman Judge, Municipal Court | 42A YES Mrs. Lawrence Draper, Jr. | 43A NO | 44A YES Joseph A. Moore, Jr. | 45A NO |