



Caldwell, David H. (2010). *Finlaggan report 2: archaeological survey of area around Loch Finlaggan*. National Museums Scotland

Deposited on: 26 November 2010

NMS Repository – Research publications by staff of the National Museums Scotland

<http://repository.nms.ac.uk/>

FINLAGGAN, ISLAY – THE CENTRE OF THE LORDSHIP OF THE ISLES
EXCAVATIONS AND FIELDWORK 1989 – 1998

PART 2 – ARCHAEOLOGICAL SURVEY OF AREA AROUND LOCH FINLAGGAN



DIRECTED BY DAVID H CALDWELL

ON BEHALF OF NATIONAL MUSEUMS SCOTLAND

PRE-PUBLICATION TEXT – SUBJECT TO CHANGE; FULL TEXT NOT AVAILABLE

Up-dated 3 November 2010

CONTENTS

Archaeological survey around Loch Finlaggan	53
Roads	53
Improved farms and recent buildings	56
Mines and quarries	59
Lead mining	59
Quarries and peat cuttings	72
Field systems and fences	74
Pre-improvement structures and settlements	89

ARCHAEOLOGICAL SURVEY OF THE AREA AROUND LOCH FINLAGGAN

The study area has already been defined as the area of the farms of Portaneilean, Mulreesh, Robolls, Kepollsmore and Sean-ghairt, as shown on the map of Islay surveyed by Stephen McDougall, 1749-51. Of these farms, only Portaneilean and Kepollsmore developed into improved single-tenancy farms, the former being re-named Finlaggan from the 1860s. The land of Sean-ghairt is now farmed by the tenant of the neighbouring farm of Ballimartin, and much of Robolls is joined with Kepollsmore. Mulreesh is farmed with Auchnaclach.

Evidence for human occupation and land-use in the area around Loch Finlaggan is relatively good from the Medieval Period onwards. Prior to that we are dealing with a palimpsest of archaeological shreds, many teased out of our programme of excavations.

The archaeological excavations on Cnoc Seannnda, and those reported below on Eilean Mor and Eilean na Comhairle, provide the evidence for occupation back to mesolithic times. There is evidence for mesolithic hunters and gatherers in the Rhinns of Islay in the late 7th and early 6th millennium BC on the basis of radiocarbon dates from Gleann Mor, Rockside, Coulerach and Bolsay (Mithen 2000, vol 1, 203, 214, 228, 281). Archaeological research on the neighbouring islands of Jura, Colonsay and Oronsay has also produced much evidence for mesolithic activity, probably extending back to earliest post-glacial times in the 8th millennium BC (Mithen 2000, *passim*). Much research into the Mesolithic Period in Scotland has focussed attention on the exploitation of coastal resources by these early hunters and gatherers. The Finlaggan lithic assemblage, by its location adjacent to an inland loch, provides evidence for the exploitation of inland resources as well.

ROADS

Loch Finlaggan is now by-passed by the main road from Bridgend, for long the administrative centre of Islay Estate, and the ferry terminal at Port Askaig on the Sound of Islay. The loch is a backwater not visible from the road, but things were not always thus. The line of the road through Ballygrant and the farm tracks off it are of relatively recent date, clearly cutting across an earlier network of roads. The map of Islay based on the surveys of Stephen McDougall in 1749-51 shows a road from Killarow (Islay House beside Bridgend) to Port Askaig which mostly follows the higher ground to the N and W of the modern road, avoiding the boggy ground down by the River Sorn. Its line is now partially represented by a farm road running SW-NE between the farm-steadings of Octovullin and Skerrols, and the road from

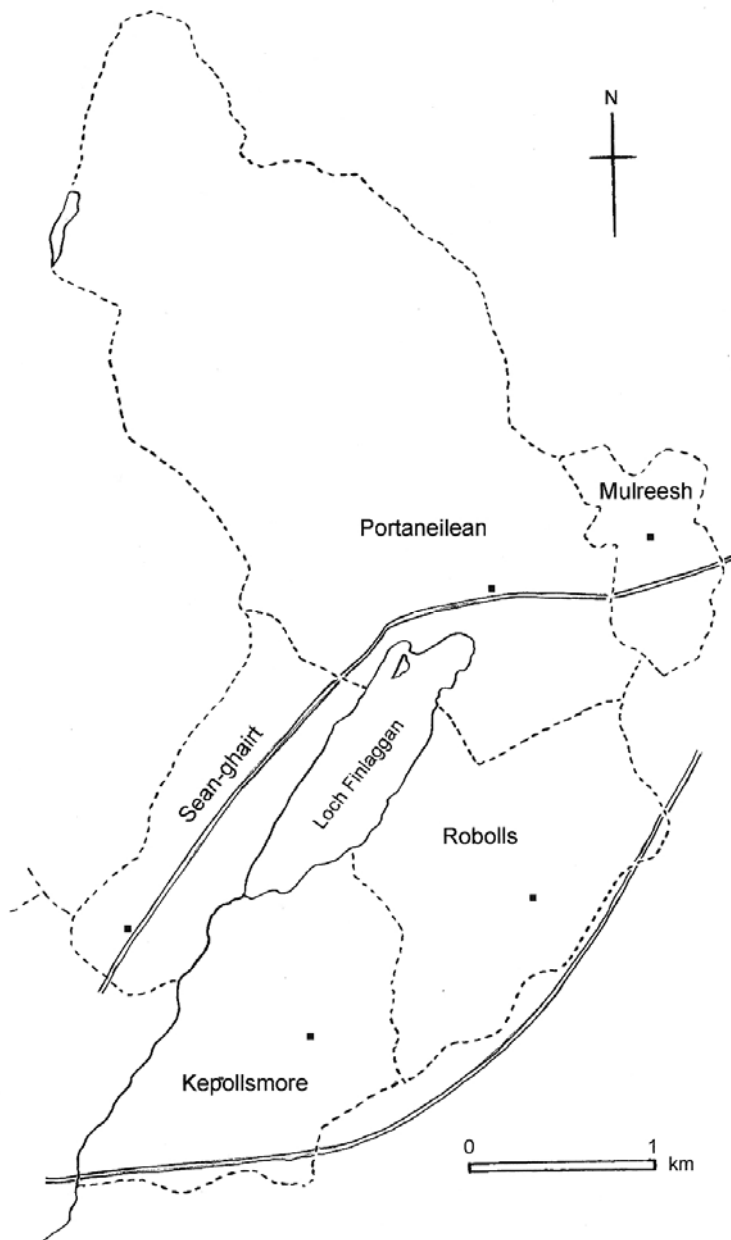

Illus 4 Routeways.

Persabus to Heatherhouse. Between Ballimartin and Persabus much of it can be traced as a track or hollow way going through the ruined settlement at Druim a' Chuirn and up the side of Loch Finlaggan through Sean-ghairt, fording the Finlaggan Burn next to Cnoc Seannda. It can then be traced to the N of the farm road to Finlaggan, heading E through Mulreesh to ford the Allt an Tairbh and continue through the ruined township of Laoigan and up to Persabus (illus 4).

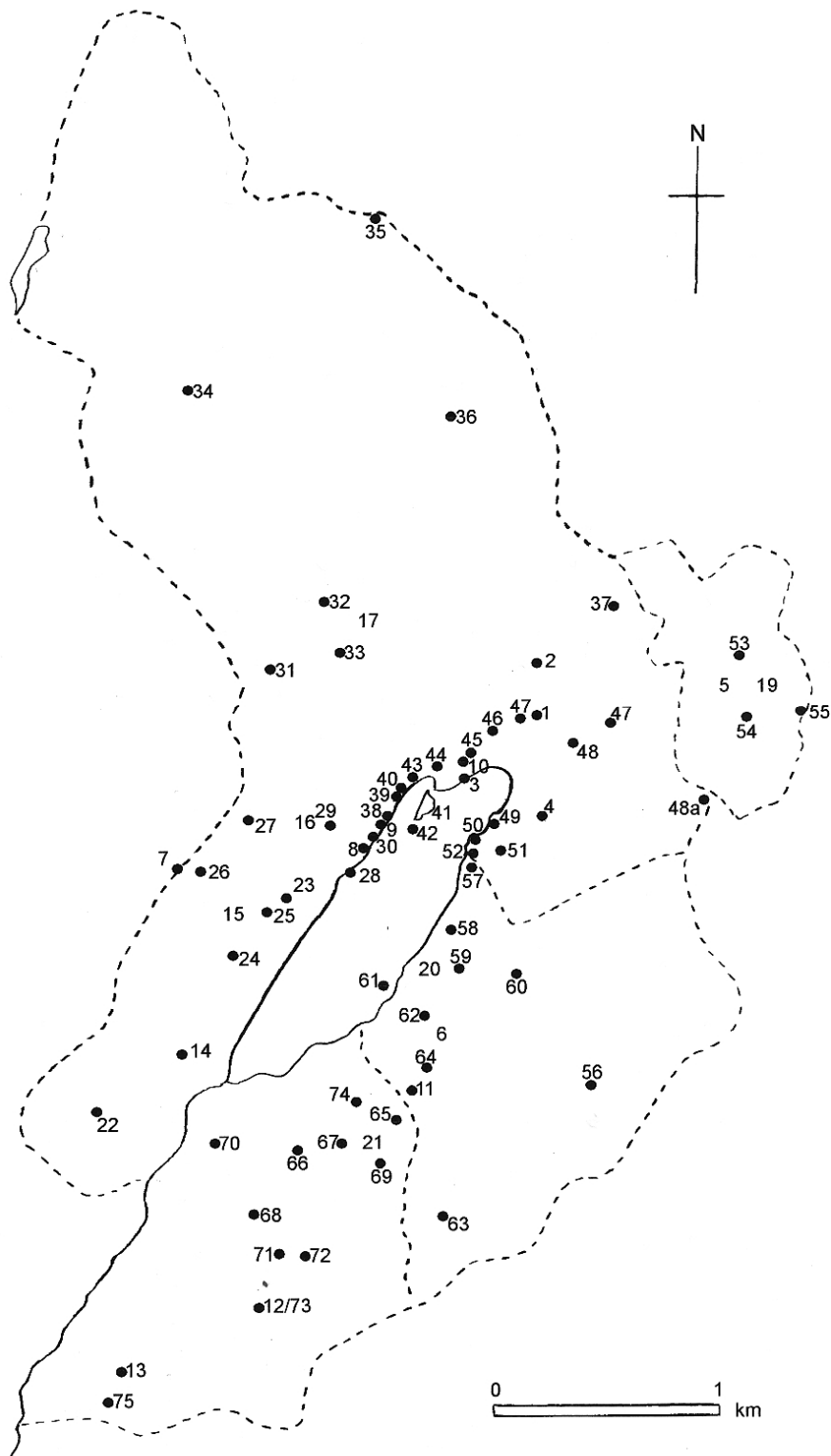

Illus 5 Map of sites and monuments.

Another road is shown looping S from this one going from Eorrabus to Persabus via Ballygrant, more or less following the line of the modern road. It may be represented by a hollow way on the higher ground parallel to the present road but to the E of Woodend farm-steading.

A key date in the development of the modern route appears to have been 1753 when the Islay Stent Committee decided that the Killarow-Port Askaig road should go via Ballygrant (Ramsay 1890, 45). The village of Ballygrant is only a development of the 19th century but there was a mill from at least 1686, a change house (inn), first recorded in 1741, and lead mining activity from at least the late 17th century (*Islay Bk*, 515, 557; McKay 1980, 106). All this no doubt helped make this seem a better route than the other via Loch Finlaggan which only passed through some joint tenancy farms. But we must suppose that the Finlaggan route was at one time the main one since it passed by the historic centre of the Lordship of the Isles.

Another early route traceable as a hollow way runs to the W of the village of Ballygrant through the Ballygrant Plantation to the ruins of the old settlement of Robolls, and then curves around the shoulder of Robolls Hill heading in the direction of Finlaggan. It stops dead where it is cut by a turf dyke at NR 3939 6766, marking the mid 18th-century boundary between Portaneilean and Robolls.

Plans of the farm of Mulreesh produced by the surveyor William Gemmill in the 1820s or `30s along with the first edition of the Ordnance Survey Map of 1878 show a winding track running from Mulreesh through the old settlement at Cul a' Bhaile NW in the direction of Cachlaidh Chreagach. Another heads this way from Finlaggan farm-steading and Buaile Mhic Iante. The farm road from Mulreesh to Balulive appears to follow the line of an earlier road. The present road to Kepollsmore farm-steading runs to the E of an earlier route.

IMPROVED FARMS AND RECENT BUILDINGS

Finlaggan not only has a steading (no 1) next to its farmhouse but another complex with house, sheepfold and milking parlour a few metres away at Buaile Mhic Iante (no 2). Sean-ghairt, Mulreesh and Robolls never developed into single tenancy improved farms. A substantial two storey house was erected at Robolls in the mid 19th century and is now the core of the Ballygrant Inn (see also no 56). There is a derelict 19th-century farm-steading and house at Kepolls (see also no 75) and a 19th-century farmhouse, farm buildings and sheepfold at Kepollsmore (no 72). The Kepollsmore farmhouse is apparently a remodelling of one of the houses occupied

by one of the joint tenants before the farm became a single tenancy in the early 20th-century.

There are few other modern or occupied buildings in the survey area. They include:

Sean-ghairt, NR 373 665, ruined farm labourer's cottage.

Finlaggan Visitor Centre, NR 391 684, ruined 19th-century
cottage restored in the 1980s. See also no 46.

Robolls, NR 401 673, 20th-century cottage.

Robolls, NR 401 672, 20th-century cottage.

Robolls, Robolls Croft, NR 398 671, a holiday home built in
2003.

Robolls, Kilmeny School (latterly village hall) and teacher's
House of the late 19th century, NR 392 661, both now
derelict.

Kepolls, NR 373 653, restored 19th-century cottage. See also no
75.

1. FINLAGGAN *FARM-STEADING* (NR 393 685)

Portaneilean was re-named Finlaggan in 1868, five years after it became a single-tenancy farm. A ledger in the Islay Estate Papers records the provision of slates, sills, lintels and flags (including some for stalls) to William Morris (a builder?) at Portaneilean in 1863 and 1864 (ML TD 13338/2/6/10 pp26-27, 189) indicating that the farm-steading dates to this time. The steading, in ruins, is a surprisingly small rectangular structure with walls of locally quarried stone, about 23.5m by 27.5m overall. The entrance in the middle of the S wall is broad enough to admit carts and wagons and gives on to a small cobbled courtyard surrounded on all four sides by ranges of buildings. Attached the length of the N exterior wall are the ruins of a 20th-century concrete milking parlour.

After several years of dereliction the adjacent farmhouse was substantially remodelled in the 1990s as a holiday home. It is a two storey house which probably also dates to 1863-64. Between it and the steading there is a heavily restored two storey out-house which may have been an earlier farmhouse, perhaps of the 18th or

early 19th century. Two of the sketches of Finlaggan made by Turner in the 1830s and now in the Tate Gallery (Finberg CCLXX, 67a, 70a) apparently show buildings here but the drawings are too indistinct to discern what.

2. BUAILE MHIC IANTE, *FINLAGGAN FARM* (NR 393 688)

About 250m to the N of the Finlaggan farm-steading are the ruins of Buaile Mhic Iante, including a milking parlour, sheepfold and cottage. The rubble walls of the milking parlour stand complete. It is a long rectangular structure 28.4m by 6m overall, with a small wing at one end, still containing several rusty and broken milk churns, trapped under a collapsed slate roof. It may also date to 1863-64. The sheepfold, about 20m by 38m, is sub-divided into six pens, the largest consisting of about two thirds of the enclosure. Built out from one end of it in concrete are the remains of a sheep-dip. A mass of collapsed and overgrown rubble at the SW corner may represent the remains of a cottage. It and the sheepfold are both represented on the 1878 OS Map but the sheepfold would appear to have been remodelled since then.

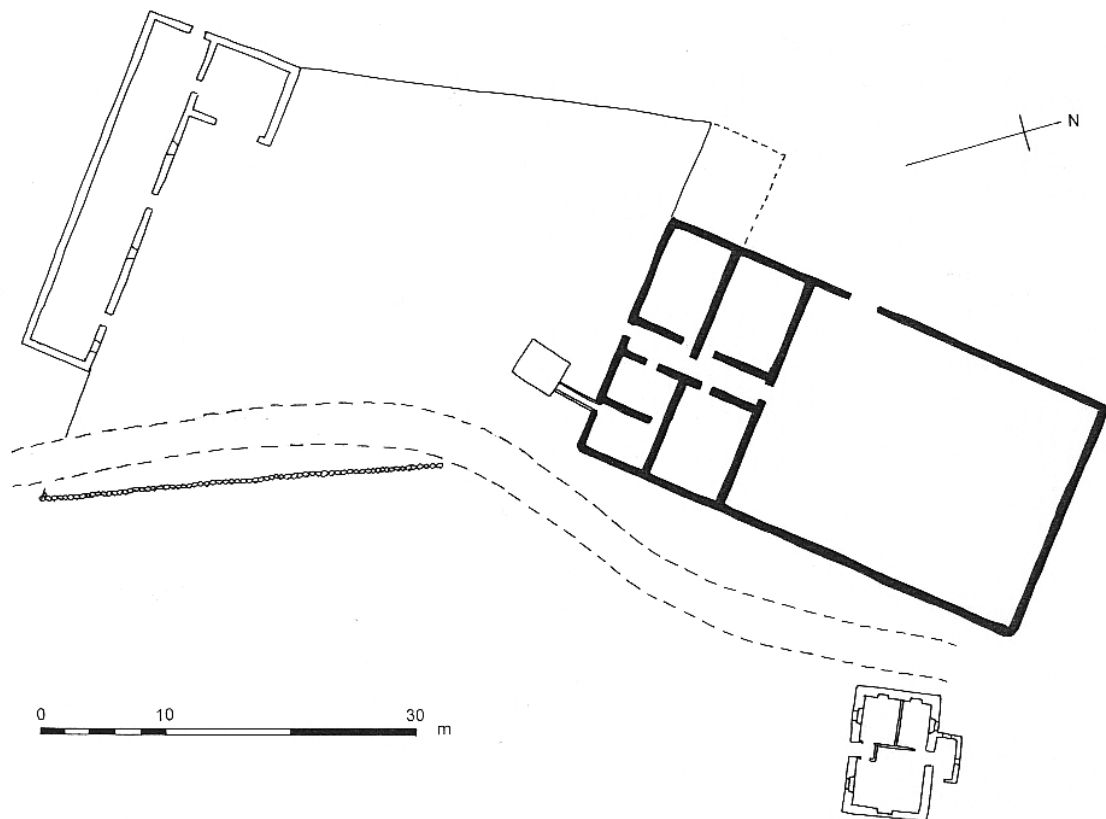

Illus 6 Buaile Mhic Iante.

Another, badly dilapidated, cottage still with a roof of local slates and brick chimneys in place, stands to the NE. It post-dates the 1897 OS Map and was probably built in the early 20th-century as a replacement for the earlier cottage by the sheepfold. It was also known as Lochview Cottage. It has sash windows and 15 amp electrical sockets. Inside the front door is a small lobby giving access to a cement-floored kitchen taking up the E half of the building. It has the remains of an iron range in the fireplace in the gable wall, shelf supports on its N wall, a hook for a lamp and a trap-door into the roof space in its ceiling. The W half is subdivided into two smaller rooms, both with fireplaces and timber floors. An outshot containing a sink masks the back door.

Behind this cottage is an area of debris, stones and defunct farm equipment overgrown with nettles and gorse. It is possible that this masks the ruins of earlier houses ('Buall-vhic'), recorded as being occupied at the time of the 1861 census. The late Mairi Macintyre suggested (*pers. com.*) that the name Buaille Mhic Iante might mean 'cattle-fold of MacIain's house'.

MINES AND QUARRIES

LEAD MINING

By MICHAEL CRESSEY

This section concentrates on the results of archaeological field survey of abandoned mine sites in and on the edge of the Finlaggan catchment. In most cases the evidence that survives on the ground is notoriously difficult to date, especially since it is clear that we are dealing with multi-period sites. Evidence of early prospecting has been identified, mostly in the region of later activity at four mines identified here as the West Shore, Portaneilean, Mulreesh and Robolls Mine. For other early prospecting on the farm of Kepollsmore see no 66 below.

A fifth mine, represented by a rubbish filled tunnel or adit, is at NR 371 664. This is presumably the level reported in 1770 to have been started at Sean-ghairt, a mine then proving too difficult to work (*Islay Bk*, 459; Callender and Macaulay 1984, 31). This level does not drain into Loch Finlaggan, and its entrance is on the farm of Ballimartin, outwith our study area.

Mining activity is represented by the following features and structures:

1. Trials, or open-cast works: trenches excavated along surface or shallow veins of ore.
2. Adits, drifts, levels: tunnels driven horizontally. Adits were used to to drain off water. Other tunnels were for working ore.
3. Bell-pits, or shafts, sunk vertically. Galleries were dug from the bottom, following the veins of ore. Most shafts have been back-filled, and are often recognisable as circular depressions surrounded by heaps of grassed over waste material.
4. Spoil heaps of debris, including tailings: crushed rock, the residue left after the ore has been extracted.
5. Industrial buildings and structures.

3. *WEST SHORE MINE, PORTANEILEAN (NR 390 683)*



Illus 7 Mine shaft on W shore.

At the head of Loch Finlaggan on the lands of Portaneilean Farm are mine workings called 'West Shore' by us to distinguish them from other workings. Situated on a geological boundary between phyllite and limestone are two shafts with surrounding spoil up to approximately 1.5m high. The more northerly of the two

shafts is on the edge of higher ground forming a level area adjacent to the mound of Cnoc Seannnda. The other shaft is close to the loch and has slightly more elongated sides. A trial has been cut into the side of the shore forming a small basin with quite pronounced internal slopes. The two shafts were possibly joined by a gallery, allowing the exploitation of a pipe-vein of galena. In 1993 an iron hoop, possibly from a kibble (a bucket for raising ore), was recovered from the loch adjacent to the trial. This mine does not appear to have developed beyond these two shafts and trial.

A document of 1770, concerning damage on the farm of Portaneilean caused by the mining activities of Charles Freebairn, distinguishes damage in 'the Winterton', that is in the area of land around the main settlement kept as arable ground. It is possible that these are the workings in question (ML TD 1338/3/4/1: Petition of Comprisement of Damages).

4. *PORTANEILEAN MINE* (NR 391 678)

These mine workings lie on a gentle slope adjacent to the NE shore of Loch Finlaggan. They are probably the cause of a compensation claim by the tacksman of Portaneilean in 1770 for damage within 'the Meadow' (ML TD 1338/3/4/1: Petition of Comprisement of Damages). The vein that was worked here was discovered c1745 along with another at Ballygrant (*Islay Bk*, 458). When reporting on the state of the Islay mines in 1770 Mr Alexander Shirriff, considering the possibility of linking the mine with nearby Mulreesh, wrote:

Portnealon vein is discovered at the surface in different places with some ore in it for trying of the vain. A cross cut is driving from Portnealon Loch (Loch Finlaggan) advanced in open cast 24 fathoms (c480m) and close drift 22 fathoms will cutt the vain in drawing 5 fathoms... If on driving north on this vain it be found to carry ore, it will serve as a level to Mulrees works to which it points. The distance may be 400 fathoms and will, when at the Mulrees works, be 12 fathoms under the old soles (old worked-out areas). (*Islay Bk*, 459).

The description accords well with the surface evidence obtained from survey of the earthworks. The suggestion that Portaneilean might be linked with Mulreesh, given the distance between the mines, appears ambitious, but field survey does hint it was attempted and possibly achieved.

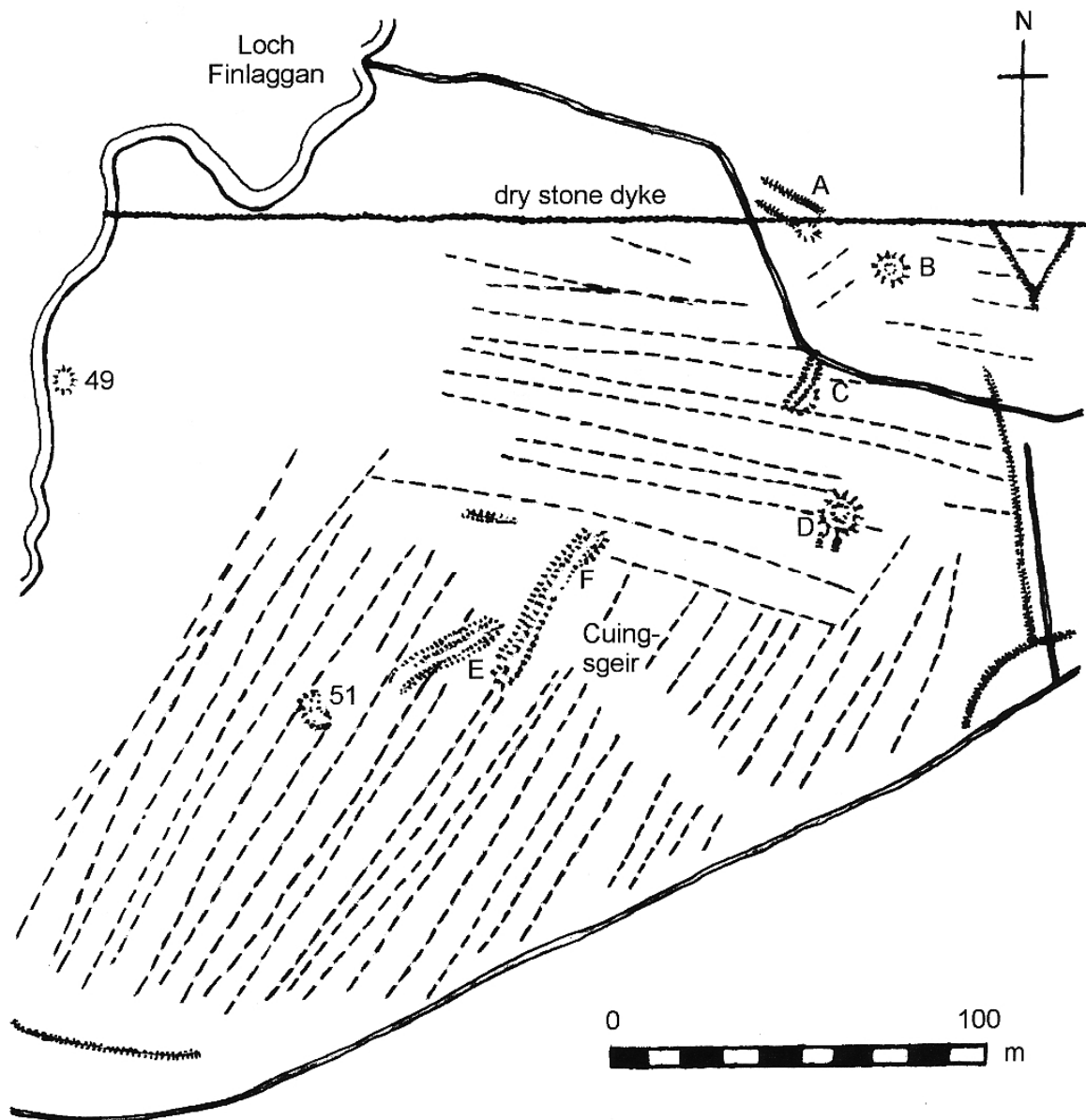

Illus 8 Portaneilean mine workings.

Illustration 8 shows a water-filled adit (A) with denuded banks up to 1m high, transected by a dry stone wall that forms the boundary between the present day farms of Finlaggan and Kepollsmore. A shaft (B) with surrounding spoil up to 2.5m is situated 20m to the N. A series of trials (C) have a depth of about 1m and each is surrounded by spoil which is 1-2m high in places. To the E of shaft (B), there is a second shaft (D) which has internal banks 2m deep with surrounding spoil to a height of 2m. To the S of these workings a natural limestone outcrop is flanked by two deep trials (E-F) that traverse up slope for about 47m. All the features

mentioned lie over or cut through the remains of the rig and furrow of the old farm of Quinskirn (no 18) last listed in a rental of 1722. This land may, of course, have been farmed long after this date as part of the farm of Portaneilean.

In the fields to the NE of these workings, extending for about 400m as far as the Finlaggan Farm road, are patches of mine tailings, and by the side of the road at NR 3955 6844 a mine shaft (or quarry?), diameter 11.5m. It might relate to Alexander Shirriff's proposal to connect the Portaneilean workings with those at Mulreesh.

5. MULREESH MINE (NR 401 687)

Freebairn was undertaking extensive mining work at Mulreesh by 1770 (*Islay Bk*, 458-9, 463) and Messrs Hodgson, Smyth and Hawkins were apparently working here 1786-90 (ML TD 1338/1/6/1). Mulreesh was the centre of operations for the Islay Lead Mining Company from its inception in 1862 until the last year of production in 1896. The Company's lease ended in 1904 and in the following year a salvage company was brought in to dismantle the workings. It was the most mechanised mine, and certainly the last to be worked in the study area. The Company had a steam driven Cornish beam engine shipped to the island in 1873. This was for pumping water from the mine shafts and for raising ore (ML TD 1338/1/6/3, 9, 14).

A NW trending vein of calcite and dolomite with galena, sphallerite, pyrite and chalcopryrite was worked in the 18th and 19th centuries. In 1770 a 64ft (24m) long shoot had been worked to a depth of 132 feet (50m). It ranged up to 4ft (1.52m) wide and the sole of the level was 10 inches to 2ft wide (c25.5 cm – 70 cm). The mine was later sunk to a depth of 300ft (114m) and worked by four levels which were 60ft (22.8m) apart (*Islay Bk*, 458-9).

Later workings followed cross-course mineral veins to form extensive connecting galleries. A schematic section drawing of the mine shafts and galleries was produced in 1874 by the mine manager H M Vercoe showing the areas of worked-out ('stoped') ground and providing the names and function of the shafts (Ill **). These shafts (Ill **, N, V, K, L) were identified in the earthworks survey undertaken in April 1994.

That the search for lead ore at Mulreesh may be of some antiquity is suggested by some trials or open casts. There are two (O) by the fence that replaced the earlier

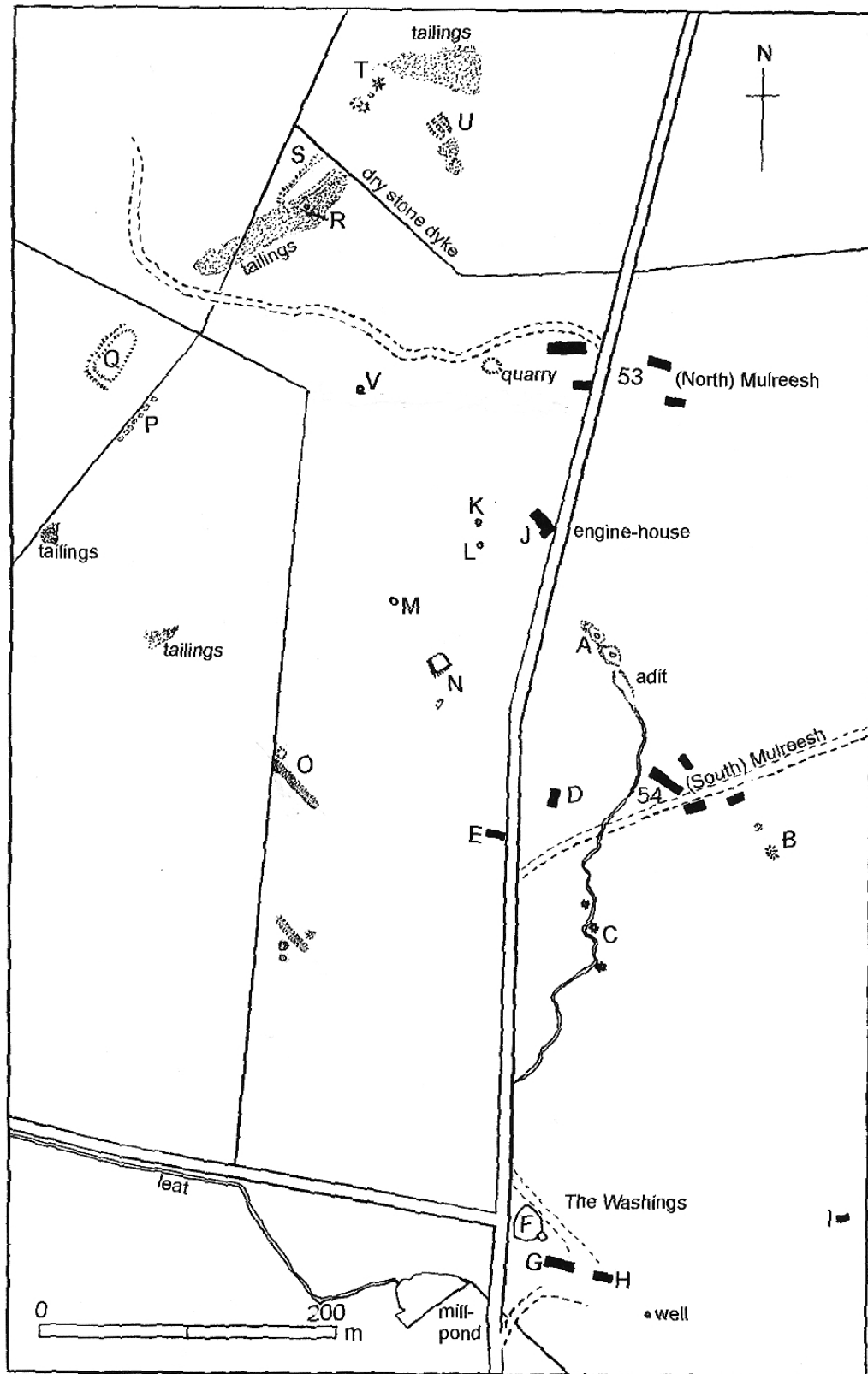

Illus 9 Mulreesh mine workings.

march dyke with Portaneilean at this point. One of them is 40m in length, 1.2m in depth and up to 5m wide, following the edge of a palaeogene dyke. There is a shaft adjacent to it, back-filled with tailings. The other trial runs parallel to the first but about 100m to the S. It is about 30m in length, 1.7m wide and 1m deep. It is this trial that is represented on the early 19th-century plan of Mulreesh, off a proposed new road near the march with Portaneilean. Nearby are two back-filled shafts and a small heap of tailings. Further N, between the 'north shaft' (R) and a dry stone boundary wall, there is another large open cast (S). A fourth trial at Sloc an Fhamhair (Gaelic, the giant's pit), NR 4034 6826, is just outside our survey area on the farm of Auchnaclach. Perhaps the name is suggestive of mining activity.

The shafts adjacent to the trials (O) may represent a later phase in the mining operations at Mulreesh. There are several others, including a series situated below the 80m contour in an area to the S of the main 19th workings. They are depicted on the early 19th-century plan of Mulreesh. There are three adjoining rubbish-filled shafts (A) on high ground just to the NW of the settlement of South Mulreesh (see below, no 54). A water-filled adit drains S, eventually to join a nearby burn. There is another small trial pit and shaft (B) on the same alignment as the others, a few metres to the SE of the houses of South Mulreesh.

Another series of three shafts (C) are positioned along the edge of an outcrop of limestone to the S of South Mulreesh, at NR 40222 68398, NR 40243 68425 and NR 40260 68486. There is a row of seven pits or shafts (P) aligned SW-NE to the SE of the catch basin (Q). They are all filled to the surface with farm refuse but their original diameter was established as 3m. More mine tailings can be observed to the S and SE of these pits.

To the N, beyond a dry stone wall, running in a SW-NE direction, is an escarpment with five small pits and a back-filled shaft. Another large tailings dump can be seen to the N of the pits. Cut into the escarpment is an adit (U) with a rubbish-filled entrance. Two large banks approximately 1.5m high lead away from the adit to an area of large boulders. The course of this adit was established as N by NE along gently sloping ground littered with mine spoil.

The most recent, late 19th-century, mining activity at Mulreesh is represented by a series of buildings, open or only partially filled-in shafts, and other features.

At NR 401 685 stand the ruins of a building marked on the 1st edition Ordnance Survey Map as a smithy (D). It is assumed to have been directly related to mining

activity. Its walls, of lime mortared quarried stones, are almost complete, but roofless, and it is divided into two rooms that originally interconnected. Both have fireplaces added against the gable walls and the ruins of outshots. In its present form the building appears to be a pair of semi-detached cottages occupied well into the 20th century. A blocked vertical slot in one gable may relate to its previous use as a smiddy. A few metres to the NE are the circular stone remains of a well.

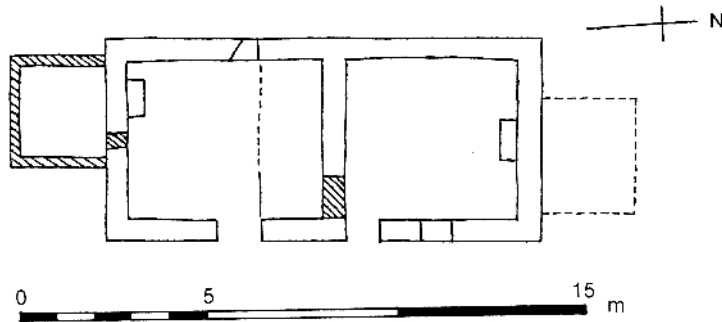

Illus 10 Mulreesh smiddy.

A few metres to the W of the smiddy, end on to the present day road to Balulive, are the ruins of a building identified as 'The Miners' Dry' (E), where working clothes and tools were kept (Callender and Macaulay 1984, 27). It is cut into a slope, has two small detached out-houses and a garden enclosed by an earth dyke. The house is constructed of quarried stones held in lime mortar. There is limited use of bricks around openings, some at least marked GILCHRIST & GOLDIE / OLD LANGSIDE ROAD / 18 GLASGOW 73. The '1873' indicates that they were manufactured in that year. This building, or a predecessor, is, however, represented on the early 19th-century plans of Mulreesh. An aerial photograph of 1947 indicates that some of its roof was still then in place. It has two rooms both entered separately from adjacent doors in the middle of the S wall. The W room is the smaller of the two but there is evidence for a window in the S wall and a fireplace in the W gable. There is a low platform against the E gable in the E room, presumably for a stove or fire. A substantial extension has been added to the E gable.

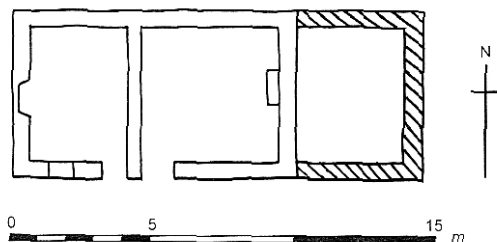

Illus 11 Mulreesh miners' dry.

Across the Balulive road to the NW of the phase 1 workings is a ruined engine-house (J), built of quarried blocks of dolerite, presumably in 1872-73. It is joined to the gable end of three derelict semi-detached cottages, all shown on the 1st edition OS Map, along with a saw pit immediately to the SW. Each house has an out-shot or substantial porch protecting the door giving access to the main room with a cement floor and a fireplace fitted with a cast-iron cooking range. A smaller bedroom with its own fireplace and sprung-timber floor is separated by a wall of timber-boards. One of the cottages was occupied as recently as the early 1970s and there was still much evidence (in 2004) of furniture and fittings, including the ranges, sash-windows, wooden shelves, an electricity supply in one, linoleum on a bedroom floor, and the remnants of bedsteads with open-work metal head-boards. There is an out-house against the gable-wall of the cottage furthest from the engine-house.

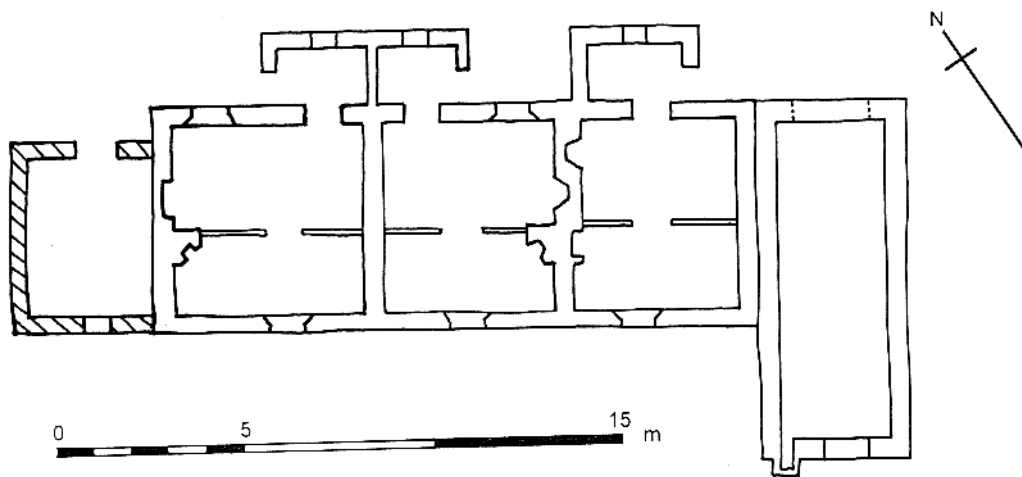

Illus 12 Mulreesh engine-house.

Beyond the engine-house there is a large tract of land pock marked with innumerable back-filled mine workings and a few fenced-off shafts, including those depicted on Vercoe's 1874 plan of the workings. The 'ladder shaft' (L) close to the engine house is lined with dressed stone and has a depth of about 40m. The 'engine shaft' (K) and 'drawing shaft' (V) are also fenced off and are too dangerous to investigate. The 'north shaft' (R) is now flooded completely but the remains of what appears to be winding gear and timbers survive at its head. Around it are large quantities of tailings, only partially grassed over. They mostly consist of an assortment of small, angular, sharply broken rocks. These are fresher looking than those elsewhere at Mulreesh and Portaneilean. The largest dump of tailings was adjacent to the engine house, but removed in the late 20th century for road-building.

Situated to the SW of the 'new shaft' (R) is a large sub-rectangular feature with banks that are in places up to 2m high, containing standing water at its N end (Q). The feature is tentatively described as a catch basin for holding water and may have been supplied by a series of wooden troughs from the 'north shaft'. The remains of a small wall adjacent to the 'north shaft' may be all that remains of a plinth to support a pump for draining water. Were this to be the case, then it would be possible that the waste water was contained within the catch basin.

A fenced-off shaft (M) of unknown date lies to the SW of the open-cast and does not relate to those shown on Vercoe's plan. It may be somewhat earlier than 1874. SE of this shaft is a rectangular feature comprising a shallow scoop with denuded banks (N). It is possible that this is the blocked entrance to the 'day level' shown on Vercoe's plan. A few metres to the S of it is a pit filled with rubbish associated with the last period of occupation of the cottages adjoining the engine house.

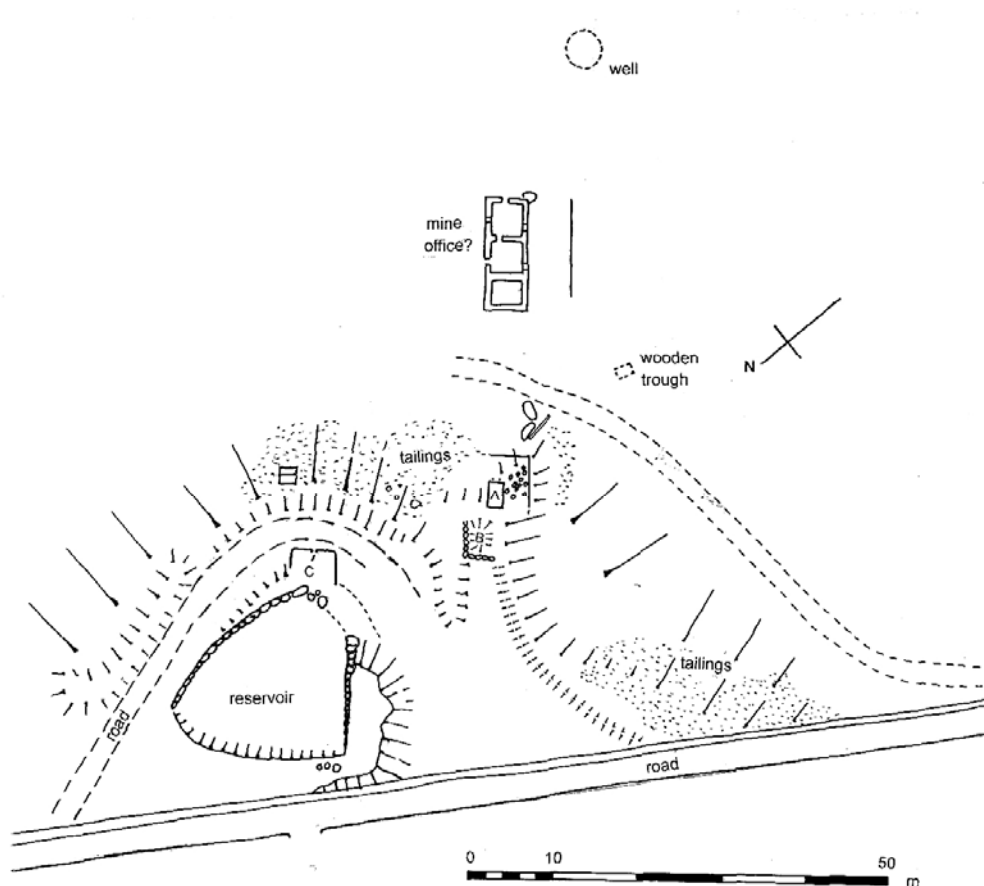

Illus 13 Mulreesh washings

Approximately 250m to the S of the engine-house are 'The Washings' where ore was crushed and washed. Water for these operations was supplied by a leat that traversed the moor for a distance of approximately 3km from Loch Airigh nan Caisteal which was artificially dammed to control a regular supply of water. The estimate of its length as six miles, given at the 1872 share-holders meeting, was presumably just an exaggeration (ML TD 1338/1/6/ 9). It, and the mill it fed, may date to the 1860s. The leat can still be traced running along the S verge of the Finlaggan farm road, and the 1878 OS Map shows it crossing under the road to Mulreesh to power a mill. This leat or water course was the cause of much concern to the farmers of Finlaggan and Balulive in the years from 1871 to 1879. Both claimed compensation for damage caused by water leaking from it (ML TD 1338/1/6/8).

Some of the water from the leat could be diverted into a mill-pond, now largely drained, in the corner to the SW of the junction of the Finlaggan and Mulreesh roads. It is likely that water was passed back into this pond for re-cycling once it had passed over the mill-wheel. Sometime after 1878 a triangular shaped reservoir (F), with internal sides about 20m long, was constructed opposite the junction with the Finlaggan road. It is partially terraced into the slope and contained by rubble built walls some 1.5m thick, coated in the interior with a mortar lining. The walls have been breached quite recently and substantial amounts of stone have been robbed for track repair. At the E end a substantial stone pier houses an iron pipe (Illus 13, C) which may have been for feeding water for operating the mill. It is not, however, well situated for this purpose and may have served some other function. On the slope below its mouth are two toppled concrete blocks, each about 1m by 2m.

The 1878 OS Map shows a substantial building (G) that may be identified as a water-mill. There is little trace of it on the ground today. A wheel-pit (Illus 13, B), approximately 2m long and 1m wide, lined with roughly dressed rubble, is situated at the W end of a broken and tumbled concrete gang-way or bridge (Illus 13, A), set with stout metal rods for supporting a water-pipe or trough. A wooden beam, some 4.8m long, may have had something to do with the trip hammer or stamp assumed to have been operated by the mill for crushing the ore. The crushed ore would then have been washed to separate the lead from the rock. Nearby are the remains of a wooden trough buried by fine tailings, probably one of the washing troughs. In May 2001 a lump of slag was picked up from the site, evidence that at least some of the lead was smelted here before being shipped off the island.

A ruinous building (H) to the E of the mill is described as the mine-office, (Callender and Macaulay 1984, 26). It is rectangular, about 14m long by 5m wide, and was sub-divided into three rooms. Its walls are of quarried limestone blocks

with bricks around the window openings. A large buttress has been applied to its SE corner to help stabilise it. There is a filled-in well a few metres to the SE. Building H was occupied as a house into the mid 20th century, being known as Ton Riabhach (Gaelic, brindled bottom).

At NR 4034 68268, well away from the other buildings, is a ruin (I) identified by Callender and Macaulay (1984, 27) as a store for gunpowder. It is rectangular, with a length of 8.42m and a width of 4.04m. It has a rectangular projection at one end, giving it an L-shaped plan. Its walls, mostly of quarried limestone blocks set in lime mortar, stand to a maximum of four courses.

A rock surface on the W side of the road from Ballygrant to Mulreesh, before the turn-off for Finlaggan, should also be noted. It is covered with initials, now mostly much worn, said to be those of the last miners at Mulreesh, and carved by them prior to their departure from the mine. This was pointed out to us by a local, Ara Fletcher, who got the information from his father.

6. *ROBOLLS MINE* (NR 388 671)

These workings (Illus 14) are to the SE of Loch Finlaggan on sloping ground about 60m from the eastern shoreline in an area covered with the remains of early agricultural activity, identified by us as belonging to the lost farm of Robolls Tannach, of which more below (no 20). The only documentation for working here appears to be a list of payments, dated 15 May 1878, owed by the Islay Lead Mining Co for damage caused by their activities. It includes an entry for 'surface damage at Robolls to date' (Islay Estate Papers, TD 1338/1/6/8). It is probable, however, that these workings include some of 18th-century and earlier date although all mention of them is missing from contemporary records.

The mine workings are all in a strip of land bounded by two parallel turf dykes, about 187m apart, running in a SE direction from the loch shore. A trial (A) trending E - W has within its interior three shafts now full of refuse that masks their true depth. Mine spoil is evident both outside and within these features and a large spoil tip (B) is situated 5m N of these shafts. Five other open cast workings (C - G) are in the immediate vicinity. Two (E and F) are dug along the edge of a palaeogene dyke. A large shaft (H), now back filled but surrounded by spoil heaps, has been dug into one of the other trials (D) where it butts on to the palaeogene dyke.



Illus 14 Robolls Mine.

The ruins of a building (I), on the edge of an escarpment overlooking the loch, are identified on the 1st edition OS map as a smithy. The building is rectangular with two rooms, and is built of quarried stone, mostly limestone with some dolerite, still standing one to two courses high, without any traces of mortar. It may have nothing to do with the mining.

Beyond building (I) to the W is a T-junction formed by recent farm tracks with one running NW into a flat area (J) that is poor in surface vegetation with mine spoil covering an area of 30 sq m. A denuded spoil tip consisting of small blocks of phyllite suggests deliberate sorting of mine waste and perhaps points to the area's use as a dressing floor. At the junction of the tracks is the entrance to an adit (K). It is now filled with refuse and flooded to a depth of about 2m, and is drained by a substantial ditch leading from it alongside the track to the dressing floor.

Callender and Macaulay (1984, 30) were able to enter this level and describe how about 80m in it opens out into a large chamber with a tunnel going off to the right (south). The photograph they publish of this (their pl X) shows rails and other debris.

An early date appears likely for the open cast features as they would generally be expected to precede the technically more advanced mining methods represented by the shafts and adit, the latter possibly all dating to the late 19th century when it is known that the Islay Lead Mining Co was working at Robolls. Two of the open cast trials (C, D) are crossed by the head dyke partitioning a complex of rigs from rough grazing. Although it is no more possible to date the head dyke closely than the trials, a 17th-century date might appear likely for the former. Three distinct phases of mining may well be separated by periods of agricultural activity. The first phase is represented by the trials (C, D) crossed by the head dyke; the second phase includes a least some of the other trials, now confined to a mining concession partitioned off by dykes; and the third phase consists of the shafts, adit and smithy.

QUARRIES AND PEAT CUTTINGS

Throughout the study area there are rock exposures which show signs of having been nibbled away for building stone. None of these quarries are of any significant size.

7. *QUARRIES, SEAN-GHAIRT* (NR 377 678)

A palaeogene dyke 9m wide running NW to SE midway between N and S Sean-ghairt has clearly cut quarried steps and is presumably the main source of dolerite used at Sean-ghairt. Two small quarries, mostly covered with turf, between this dyke and S Sean-ghairt could have been the source for dolomitic sandstone. There is a quarried area above building Q that is less clearly defined than the others and is the likely source for the quartzite used, while dolostone could have been got from the low cliffs on the S edge of the S cluster.

8. *CLAY PIT, SEAN-GHAIRT* (NR 385 6800)

To the NE of North Sean-ghairt there is an area of boulder clay, extensively pitted for clay extraction. The farmer, Mathew MacMillan, thought that at least a little of this may have been done 'recently' for road improvements.

9. *CLAY PIT, PORTANEILEAN* (NR 386 680)

A rectangular cut in the steep bank of the loch may be a clay pit rather than a house platform.

10. *QUARRY, PORTANEILEAN* (NR 390 683)

Near the shore of Loch Finlaggan beside the Finlaggan Burn, is a small limestone quarry that could have been the source of some of the stone used in the medieval buildings on Eilean Mor.

11. *PEAT CUTTINGS, ROBOLLS* (NR 388 667)

In a small valley extending NE from Dun Cheapsadh Mor.

12. *QUARRY, KEPOLLSMORE* (NR 382 659)

A dyke has also been quarried next to the old road to Kepollsmore at the alleged site of a burial ground (no 73).

13. *QUARRY, KEPOLLS* (NR 375 655)

A disused quarry is marked on OS maps to the W of the Kepolls farm-steading. There is evidence here for the quarrying of phyllite and a dyke.

FIELD SYSTEMS AND FENCES

The area of the old farms in the study area are listed in Scots acres as follows in a 'View of Contents of the Baroney and Estate of Islay' (Ramsay 1991, 63-67), thought to have been drawn up by Stephen MacDougall (approximate equivalents in imperial and metric computed by the writer):

		<i>Acres</i>	<i>Roods</i>	<i>Poles</i>
Shangart:	Arable:	122		
	Green pasture:	54		
	Heathy pasture:	107		
	Totals: Scots:	283		
	Imperial:	359.41		
	Hectares:	145.51		
Portnellan:	Arable:	200	1	12
	Green pasture:	59		
	Heathy pasture:	680	2	12
	Totals: Scots:	939	3	24
	Imperial:	1193.55		
	Hectares:	483.22		
Mulreesh:	Arable:	65	2	16
	Green pasture:	61	1	
	Heathy pasture:			
	Totals: Scots:	126	3	16
	Imperial:	161.04		
	Hectares:	65.20		
Robolls:	Arable:	172	2	38
	Green pasture:	121		
	Heathy pasture:	100		
	Totals: Scots:	393	2	38
	Imperial:	499.87		
	Hectares:	202.38		
Kepollsmore:	Arable:	240	2	
	Green pasture:	38		
	Heathy pasture:	62		
	Totals: Scots:	340	2	
	Imperial:	432.44		
	Hectares:	175.08		

The total area for the whole estate (almost all of Islay) is given as 110787 Scots acres, and the 171 farms vary in size from 4695 to 40 Scots acres. The 1741 rental (Ramsay 1991, 37-44) gives the extent (valuation) and rent of two of the farms in our survey area:

Portnellan: 5 lewres (£2 1s 8d); rent £25 10s 1d

Kepelsmoir: 1 quarter and 1 eighth (£2 10s); rent £19 2s

The ratio of rent to extent of these two farms seems to compare favourably with others listed in the 1741 rental, suggesting that they were good properties. Sean-ghairt and Robolls were quarter lands (£1 13s 4d). The former was held by a tacksman with two other farms, the overall rental suggesting that it did not provide much of a return. Robolls was wadset (mortgaged) to Ronald Campbell of Ballachlaven and it is impossible to gauge its worth.

The threefold division in the 18th-century 'Contents of Islay' of land into arable, green pasture and heathy pasture is axiomatic of the system of runrig farming practised in Scotland at the time. The arable consisted of the rigs in regular cultivation. It was still the practice on Islay in the 1830s that the rigs of the different tenants on a farm were intermixed, and re-allocated every three years (Teignmouth 1836, ii, 308). These rigs, either individually or in groups, were often unenclosed.

Rigs are long, thin, raised beds, separated by furrows. They are normally orientated so that water can drain off down the furrows. It is not clear from fieldwork alone to what extent any rigs in the survey area were created and maintained by ploughing. Many, often called lazy-beds, were made by turning over the turf with spades, and mounding it up. Lazy beds were still being dug like this on a small scale on Islay in the first half of the 20th century for growing potatoes.

The heathy pasture was the rough grazing or moorland where the animals were taken in the summer, well away from the growing crops. It was separated from the latter by a 'head dyke'. Shielings (huts) for the women and children tending the animals are often located just beyond the head dykes. The green pasture was the better quality pasture within the head dyke, sometimes manured and cropped.

Most of the study area has not been ploughed or cultivated in recent memory, with the notable exception of a large swathe of land to the NW of Loch Finlaggan which was planted in the 1980s with conifers. Much of the rest of the land that was formally used for agricultural purposes is now merely used for pasture or the occasional crop of silage. The present field system consists of large rectangular areas enclosed by straight stretches of wire fences or dry stone walls. Many are four-sided. Past ploughing has obliterated traces of rigs, and drainage is provided by sub-surface drains and open ditches at field boundaries. Fields like this are concentrated at the N end of Loch Finlaggan, and also to the SW of the loch at Druim a' Chùirn. Some of the names of fields on Finlaggan Farm have been handed down by the daughter of one of the tenants who lived there in the first half of the 20th century (illus 15).

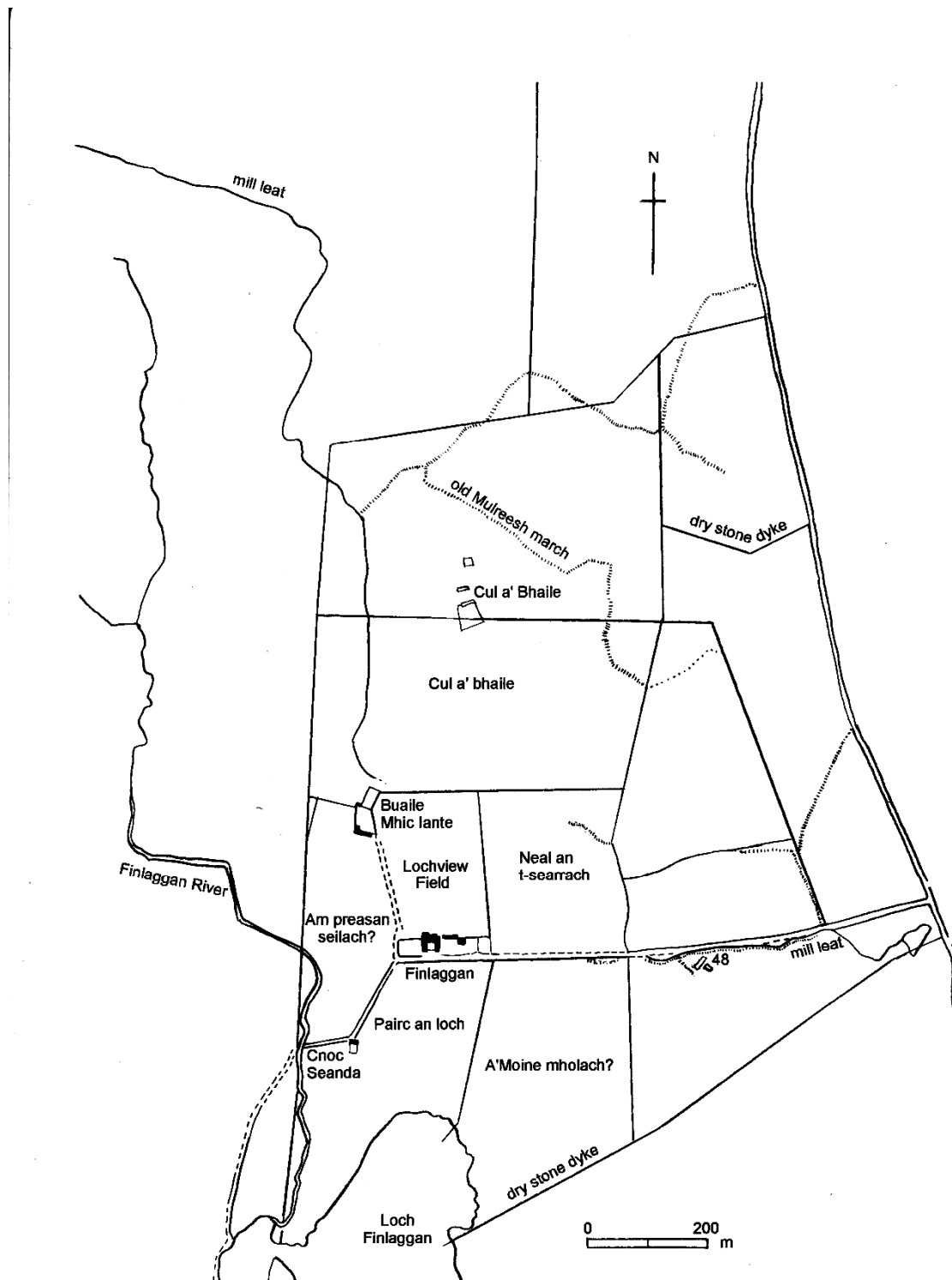

Illus 15 Finlaggan field names.

Three earlier systems for arable cultivation can be recognised:

1. Small, irregular fields of rigs enclosed by turf dykes. At least some of these may be of considerable antiquity. The need for dykes implies they were created prior to the construction of head dykes.

2. Unenclosed groups of rigs within a head dyke.
3. Small, quadrilateral fields containing rigs. Fields like this imply that the tenants had moved away from a system of intermixed rigs re-allocated at regular intervals to a permanent division and consolidation of the arable. They represent a relatively recent development, perhaps only of the late 18th or early 19th century.

Four main types of dykes and fences can be distinguished in the study area:

1. Turf dykes, with or without a significant stone content, sometimes in the form of boulders or large stones placed at regular intervals when the dyke was being set out. Sometimes it is only these ('dog teeth') which remain. Illus 16 shows the section of a turf dyke on the old farm of Robolls at NR 3900 6768, near the side of the loch. It has been cut by a small burn and the trampling of cattle. It appears to have been heaped straight on top of the grass. Thin horizons of small pebbles, representing the underside of turfs, suggest at least two heightenings of the original bank.
2. Dry stone dykes. There is a considerable variety of these on Islay, but in the study area they are of quarried stone with stone or turf coping. These dykes were professionally built, and date to the 19th century when, it is said, dry stone dykers were brought in from Durham, Northumberland and Galloway (Ramsay 1991, 105). The Islay rental of 1833/4 records that the farmer of Ballimartin and half of Sean-ghairt was paying interest on a loan for stone dykes, perhaps including those at the SW of Loch Finlaggan. Although many dry stone dykes are still kept in repair none have been constructed in the study area in recent times.
3. Wire fences with metal stobs. The stobs are set in concrete and there are often drainage ditches on either side of the fence. None are now in a state of repair, and we have been informed by a local farmer that they date to the mid or late 19th century.
4. Wire fences with wooden stobs. These are typically the fences still in use or being erected today.

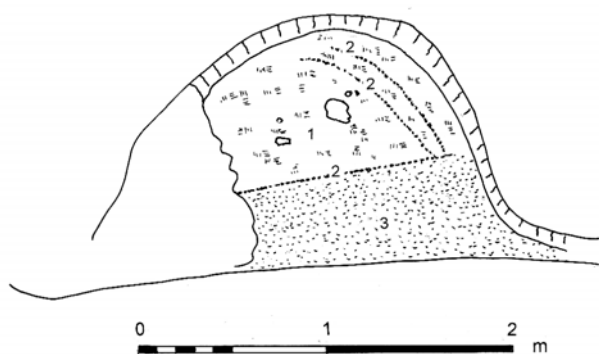

Illus 16 Dyke section, Robolls. (1) yellow/green clayey silt (2) horizons of small pebbles (3) brown silty sand full of sharp flakes of limestone.

Although the names of the farms that surround Loch Finlaggan are obviously of considerable antiquity, this does not mean that we have to assume that the marches between them are equally ancient. Indeed it can be argued that the exact opposite is true, that the presumption should be that march dykes are relatively recent.

Stephen MacDougall's surveys of Islay dating to 1749-51 did not just lead to an overall map of Islay. They were primarily about establishing the acreage of each farm. Until his work the only way the extent of each farm was measured was by its rent in money and in kind. No doubt the tenants of each farm were well aware of the boundaries of their land, but what must have been of more importance to them were the divisions between their fields or rigs of arable, and securing their crops from depredations by cattle. For many Islay farms the shielings were fairly close to the arable land and the beasts must have been herded to prevent them from straying on to the crops or neighbouring farms where there were no dykes or fences to hold them in. Late 18th-century writers, including Pennant (1776, 261) and Walker (1812, i, 103) commented on the lack of dykes.

The standard leases for Islay farms issued by the laird from the 1770s required the tenants to build proper march dykes. They not only had to straighten the marches in the process but also exchange pieces of ground with neighbouring farms, all for the improvement and good order of the country (Ramsay 1991, 97). Since the dykes that the tenants then had the resources to build themselves were traditional style ones of turf and stone we might expect that many such march dykes, particularly relatively straight and distinct ones, like those separating Portaneilean from Sean-ghairt and Robolls, were first laid out in the late 18th century.

The rationalisation of marches required by the laird can be appreciated by comparing the boundaries of farms elsewhere in Islay as depicted on MacDougall's map with those on plans of the 1820s and '30s attributed to William Gemmill. In many cases the boundaries have not only been straightened out, but large tracks of land have changed hands (Storrie 1997, 122-31). It is also clear that by the early 19th century, while the traditional farm units still had some meaning, their marches were not yet completely marked out with dykes. The early 19th-century farm plans distinguish between marches defined by 'fences' and those which were merely 'calculated'. All of this should make us wary of expecting any march dykes to be of great age.

The mid 18th-century loch-side boundaries of Sean-ghairt, Portaneilean, Robolls and Kepollsmore all appear to have coincided with burns, as also much of the march between Portaneilean and Balulive, and the march between Robolls and Kepollsmore

on the one hand, and Ballygrant, Kilmeny, Tiervaagain and Esknish on the other. Turf dykes were erected along one of the banks of at least some of these burns.

Boundaries of a different sort are represented by those between Sean-ghairt and Ballachlaven, and Ballachlaven and Portaneilean. The former, defined by a turf dyke, runs along the summit of Cnoc an Tighe, enclosing a very small area of rough pasture in Sean-ghairt relative to the extent of its arable. It appears likely that Ballachlaven and Portaneilean had by the mid 18th century expanded at the expense of Sean-ghairt. MacDougall's map of Islay and his survey of Ballachlaven show the march between Portaneilean and Ballachlaven following a water-shed via a small loch, Loch Carn nan Gall, to the summit of Carn a' Choinnler (Gaelic, cairn of the candlestick) at over 260m above sea level. Looking at Islay as a whole, watersheds more often represent divisions between farms than streams, and lochs are often on the boundary of two or more farms.

The march between Mulreesh and Laoigan to the E is formed by the Allt an Tairbh. Mulreesh's boundary with Portaneilean, however, seems less determined by obvious physical features, perhaps because it was detached from Portaneilean or another farm in the distant past.

Long straight lines of fence stretching across the moors indicate that Finlaggan/Portaneilean was at one time much larger than indicated by the mid 18th-century survey. They show that Finlaggan had expanded northwards to Loch a' Churragan, taking in land formerly in Ballachlaven, and NE to include much of the rough pasture of Balulive. It is likely that these fences date to the time that Finlaggan was given over to sheep, during the tenancy of the brothers, Alexander and James Greenlees, who farmed Finlaggan from 1871 to 1885.

The straight dry stone wall that runs from near the top end of Loch Finlaggan eastwards dates rather earlier. Rentals from 1815 record that a part of Portaneilean had been detached to augment the farm of Robolls and this dyke may date to that time. It cuts through the Portaneilean mine workings and is a rationalisation of an earlier Portaneilean – Robolls boundary, represented by a turf dyke further S. It joins up with an unnamed burn flowing into the loch.

Several pre-modern field systems survive in the survey area. It is reasonable to assume that other extensive systems have been destroyed by late 19th and 20th century farming practices at Druim a' Chùirn at the SW end of the loch, around the

head of the loch and extending over to the Mulreesh road, at Robolls (around the Ballygrant Inn), and around the present farm steadings of Kepolls and Kepollsmore.

14. *COPPICE, SEAN-GHAIRT* (NR 378 670)

A wood of mixed oak and hazel, about 200 sq m in extent, just to the SW of Loch Finlaggan. It has been managed in the past to produce thin wands for wattles, roofing, etc. There are still many small patches of coppice in Islay, the residue of 'the spots of Coppice from 5 to 30 Acres, and in one place ... above 100 Acres' observed in the late 18th century by the Rev Dr John Walker (McKay 1980, 102).

15. *FIELD SYSTEM AND HEAD DYKE, SEAN-GHAIRT* (NR 381 676)

Around the two clusters of ruined houses forming the 19th-century township of Sean-ghairt are the extensive traces of a system of unenclosed rigs, partially removed by 20th-century ploughing between the two settlements in the area adjacent to the loch. There are also some straight dykes, probably forming a series of quadrilateral fields of more recent date than the unenclosed rigs. These rigs can be identified as the Sean-ghairt infield. There are other more sporadic groups of rigs further out from the settlements, representing the outfield. The rigs are all about 2m wide and aligned with the slope down to the loch.

A sinuous turf and stone dyke, still over a metre high for much of its length, encloses these rigs as well as field system no 16 (see below). It runs approximately SW-NE and its course beyond field system no 16 is now lost through the creation of a conifer forest in the late 20th century. It apparently progressed eastwards to near the edge of Loch Finlaggan, possibly joining up with other dykes to form part of a continuous system all the way to the coast of the Sound of Islay at Bunnahabhain, also protecting the arable land of Balulive, Staoisha, Staoisha Eararach and Ardnahoe.

Heading SW, the Sean-ghairt head dyke bifurcates. One prong separating the supposed infield from the outfield may represent an earlier line. The other further upslope forms the march with Ballachlaven before joining up with the head dyke for Ballachlaven, from whence a continuous head dyke extended through the farms of Baile Tharbhach, Duisker and Balole. It appears that Ballachlaven has cut Sean-ghairt off from access to the moor, only a relatively small area of rough pasture remaining within the Sean-ghairt march dyke. The march between the two farms, and the new line for the Sean-ghairt head dyke, may have been created sometime after the Sean-ghairt farmers became sub-tenants of the Campbells of Ballachlaven in the 17th century.

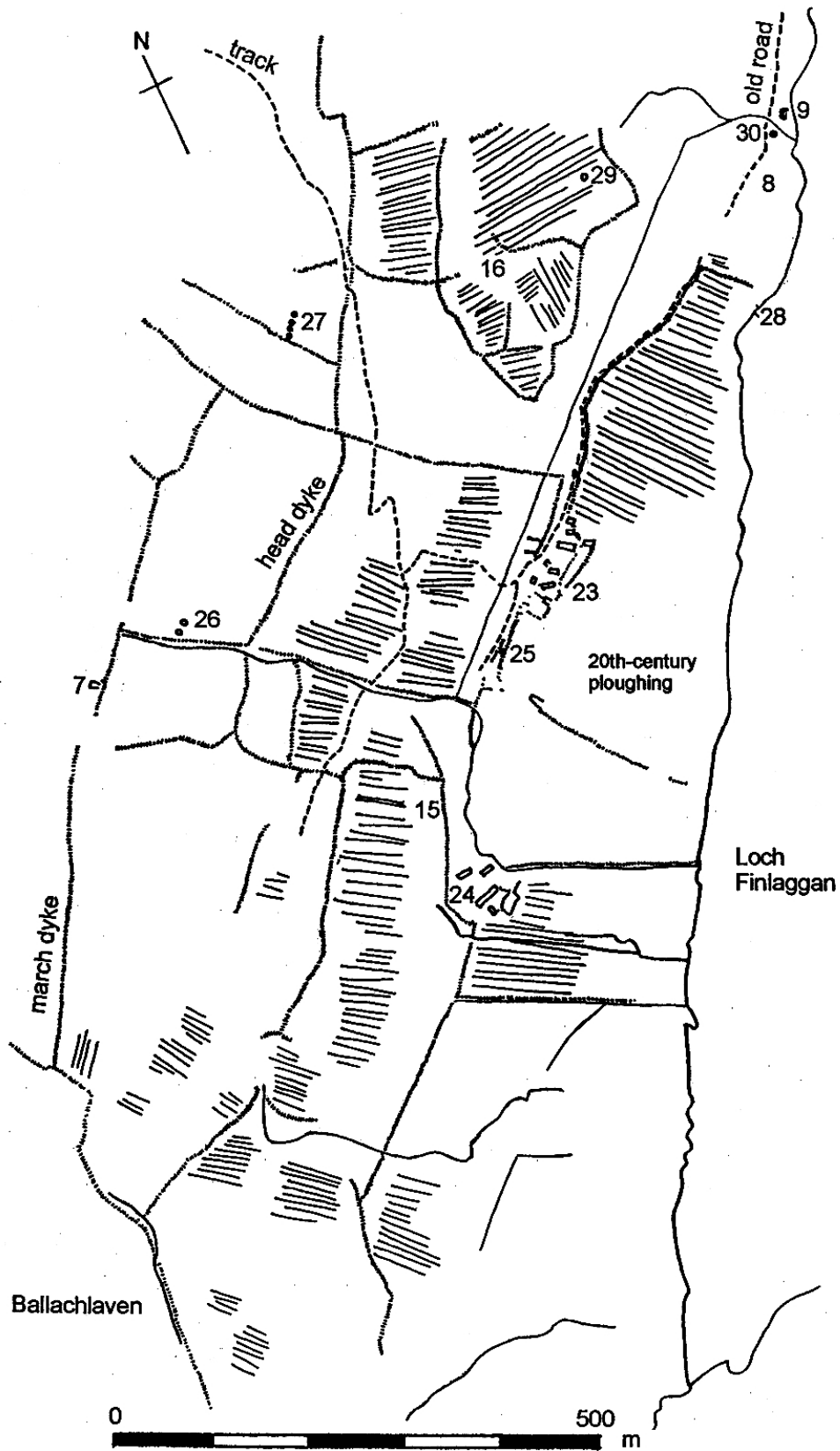

Illus 17 Sean-ghairt field systems.

16. FIELD SYSTEM, SEAN-GHAIRT (NR 383 681)

Within the Sean-ghairt head dyke and stretching to the march with Portaneilean there is a group of five small irregular fields containing rigs. They vary in size from about 50m by 66m to 120m by 180m and are separate from the field system (no 15) just described. They are probably of earlier date. They may tentatively be identified as the arable of the lost farm of Laichtcarlane.

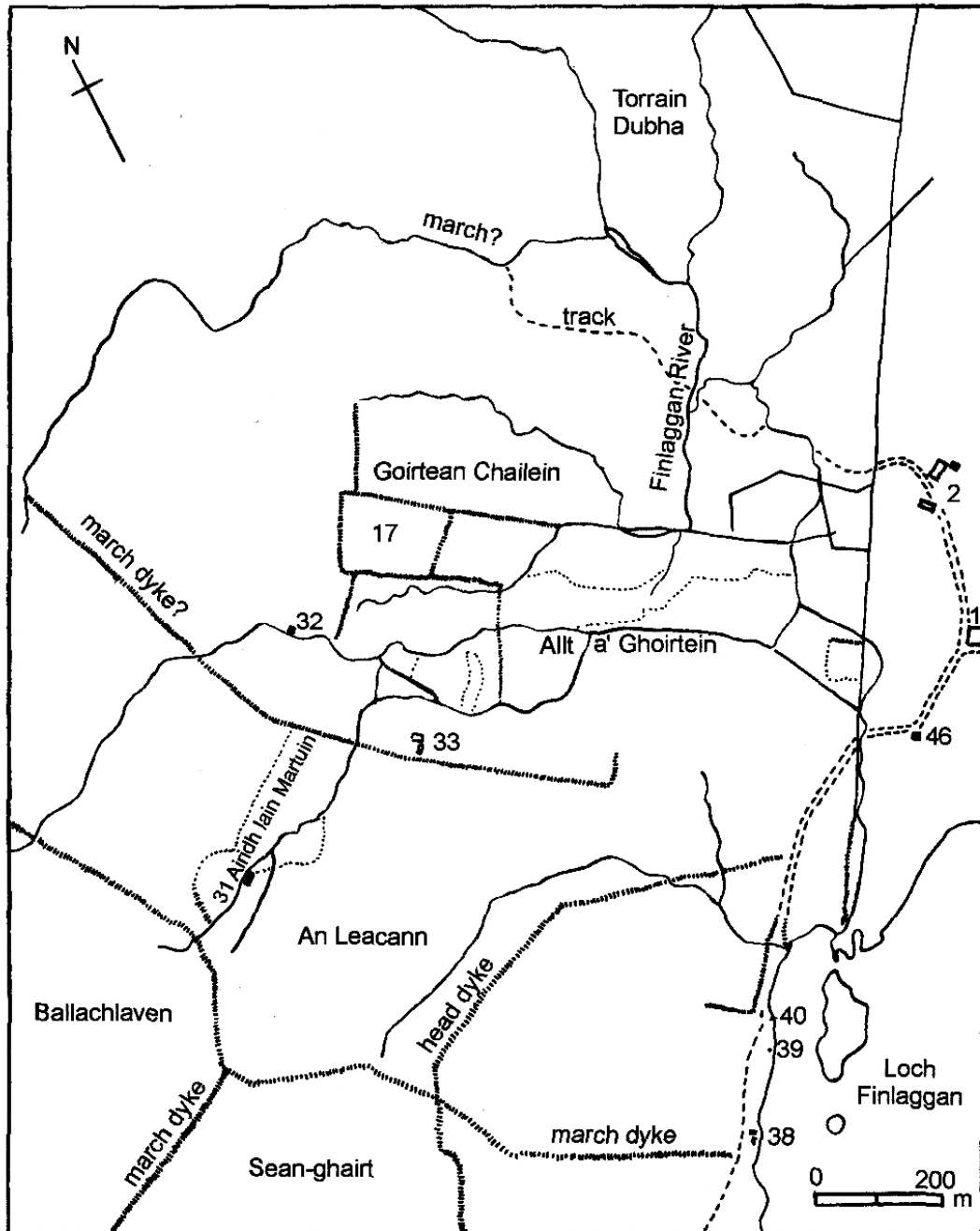

Illus 18 Goirtean Chailein.

17. FIELD SYSTEM, GOIRTEAN CHALEAN, PORTANEILEAN (NR 386 690)

This field system at An Leacann (Gaelic, the hillside) is associated with a small ruined settlement (see below, no 33), and probably also the house, no 32. The fields are now lost in a recent conifer plantation but were small and quadrilateral, probably dating to the 18th or early 19th century. Houses and fields are enclosed to the SW by a substantial turf dyke, which, with a tributary of the Finlaggan River to the NW and NE possibly define the extent of this holding.

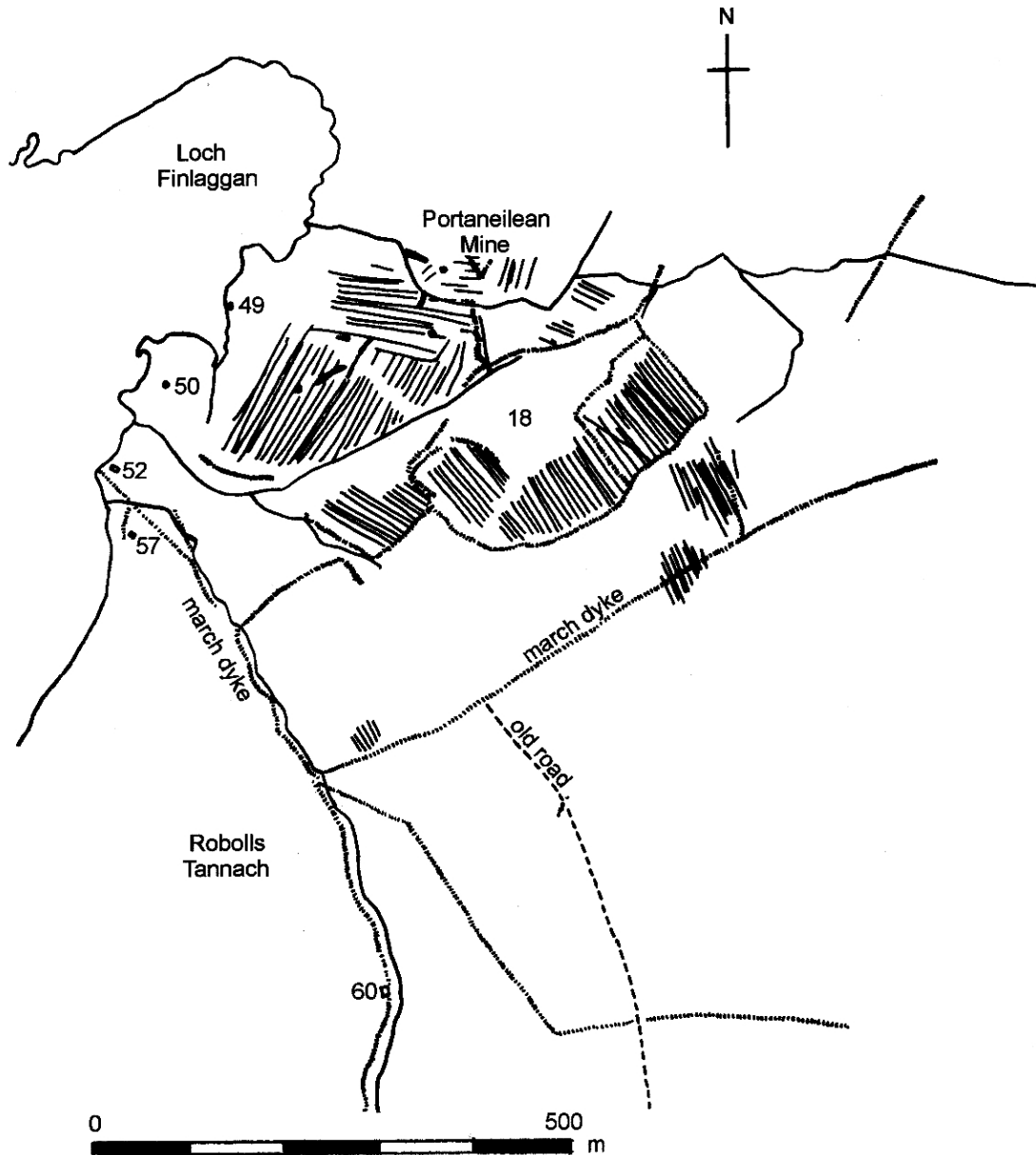

Illus 19 Cuing-Sgeir

18. FIELD SYSTEMS, CUING-SGEIR, PORTANEILEAN (NR392 680)

Cuing-sgeir is clearly the modernised spelling for the old farm of Quinskirn, lying within the mid 18th-century boundary of Portaneilean. The lost farm of Kylladow may also be located here and be represented by some of the rigs and fields in this group.

There are two unnamed burns flowing into Loch Finlaggan about 300m apart with rigs and dykes between them and to the N and S of them, extending up to the mid 18th century march between Portaneilean and Robolls. They are partially truncated by the dry stone dyke that now forms the boundary with Kepollsmore. They possibly extended north-eastwards to the unnamed settlements on the Finlaggan Farm Road (no 48) and beside the Mulreesh road (no 48a). There is a group of 7 rigs at NR 400 681 adjacent to the Finlaggan side of the march fence with Kepollsmore. Those between the southern of the two burns and the Robolls dyke form a tight complex of small fields enclosed by dykes and may be of earlier date than the unenclosed rigs to the N. The latter are cut by open-cast mine workings which may relate to activity from about 1745 onwards. A claim made in 1770 for compensation for mining damage suggests that the land here was at that time meadow, no longer arable land (see no 4 above). For huts and houses associated with these field systems see nos 49-52.

19. FIELD SYSTEM, MULREESH (NR 402 685)

Not much of the pre-improvement field system at Mulreesh can be traced on the ground, and it has been disfigured by lead mining activity. Two plans of the property, apparently produced by the surveyor William Gemmill in the 1820s or '30s, do, however, provide a considerable amount of detail. They are practically identical, though one includes some of the mine workings, and compare well with early Ordnance Survey maps in terms of accuracy.

The E side of the farm, marching with Ballighillan and Scanistle (Laoigan and Auchnaclach), is defined by the Allt an Tairbh and one of its tributaries. The rest was bounded by turf dykes, some of which can still be traced. The land was traversed E-W by the old road from Loch Finlaggan to Port Askaig, with another road branching off N to Balulive, and there were two clusters of houses (see below nos 53 and 54). The fields are irregular in shape and size, numbered from 1 to 10 (but including the houses and yards as one). Two thirds of the land are marked as arable, the rest as pasture. Some of the pasture merely consists of irregular patches in arable fields, evidently rocky outcrops and steep slopes too difficult to cultivate.

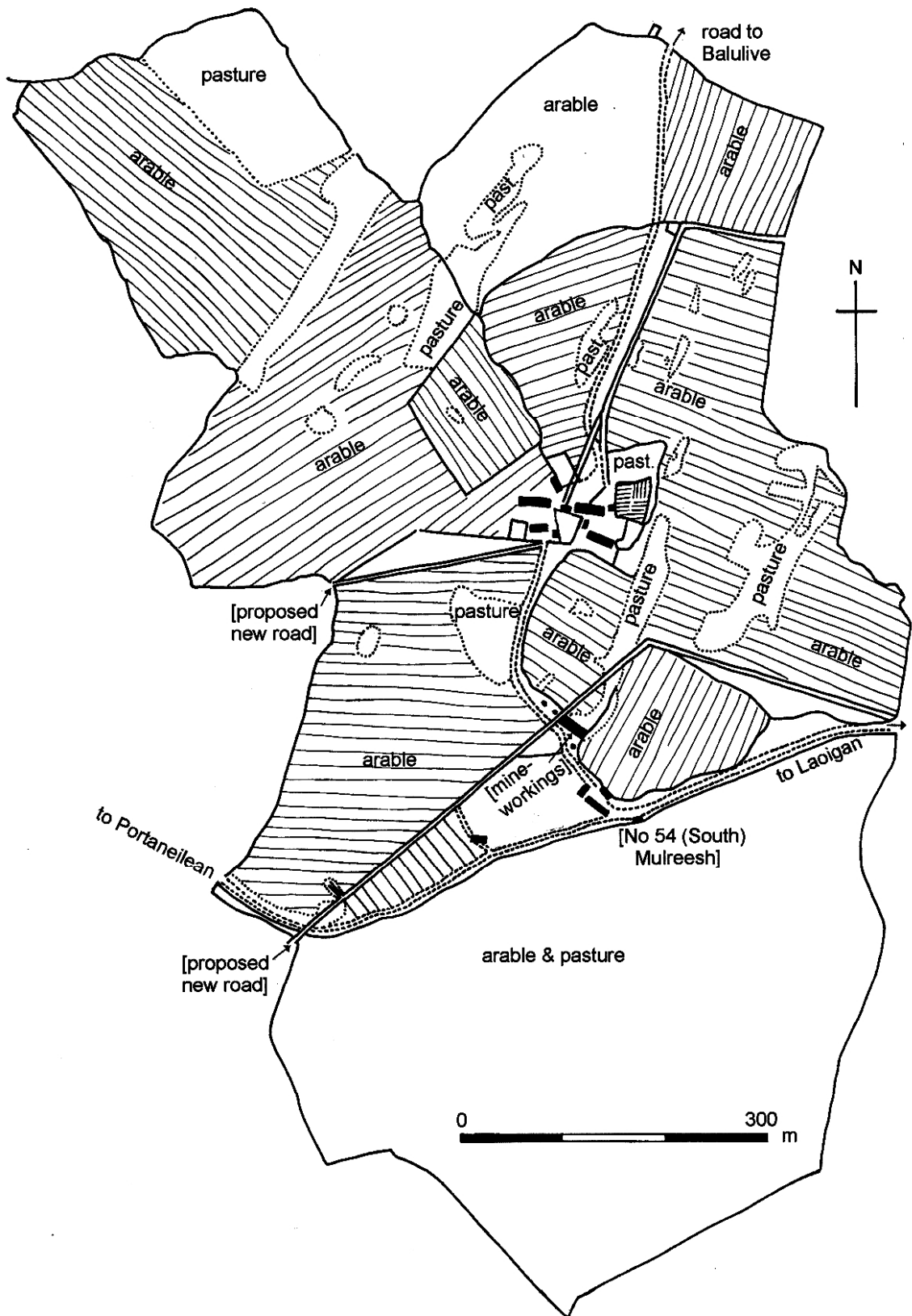

Illus 20 Mulreesh field system, after early 19th-century plan.

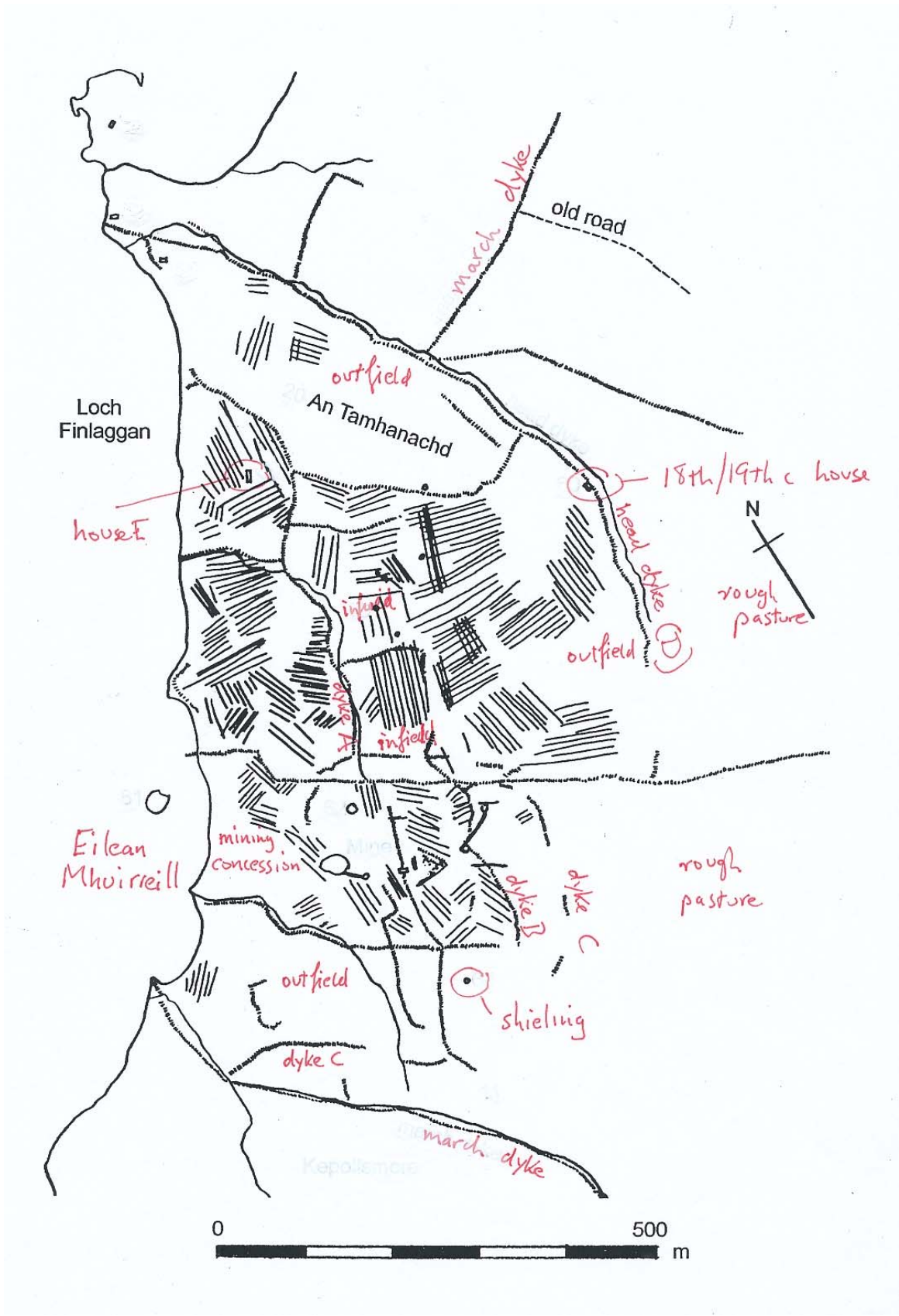

Illus 21 Field system, An Tamhanachd, Robolls

20. *FIELD SYSTEM, AN TÀMHANACHD, ROBOLLS (NR 388 675)*

An Tàmhanachd reflects the name of an earlier farm known as Robolls Tannach, probably the original Robolls, centered on Eilean Mhuireill. We have already noted (see no 6) the Robolls mine workings within this field system spreading along the shore of Loch Finlaggan. Mining activity, particularly the second phase with the smithy, adit and shafts, is confined to the S segment, within a strip of land defined by two parallel turf dykes, about 187m apart, running in a SE direction from the loch shore. Both may have been constructed to define this particular mining concession.

Within the mining strip are several groups of unenclosed rigs and stretches of turf dykes, some of which may be associated with the mining activity. One dyke (B), tracing a double-bow and erected across two earlier open-cast mine-workings, effectively marks the divide between green and rough pasture. It can also be traced extending into the field systems immediately to the N. There are traces of another dyke (C) about 55m further out with a small group of rigs between it and dyke B. It probably returned westwards to the south of the mining strip to terminate on the march with the neighbouring farm of Kepollsmore. There is a shieling hut (no 64) to the S of the mining concession within the line of dykes B and C.

In the larger zone of old arable to the N of the mining concession another sinuous dyke (A) takes off from the loch edge, curves round southwards and is cut by the dyke forming the N edge of the mining concession. There are traces within it and between it and dyke B of other dykes forming enclosed fields, and a considerable density of rigs, some cutting across earlier ones. Another dyke (D), still defining the division between green and rough pasture, forms a quadrant of a circle with ends on the loch-side and the mining concession dyke. For most of its length it follows the bank of an unnamed burn round to where it enters the loch. Between it and dyke B are several groups of unenclosed rigs. The foundations of a small house (no 60) on the inner edge of dyke D are clearly of late 18th- or 19th-date but a house-site (no 58) may represent the remains of a long house of earlier date.

All of this suggests a possible chronological sequence for the agricultural and mining remains at Robolls Tannach as follows:

- 1 Field system on the lower slopes adjacent to Eilean Mhuirreill with rigs in small enclosed fields, the outer limits of agriculture defined at first by dyke A, possibly with dyke C serving as a head dyke marking the division of green from rough pasture.
- 2 Mining activity characterised by open-cast workings. Some, at least, of these workings could be earlier than the system of enclosed fields.
- 3 System of enclosed fields expanded uphill to the line of dyke B.
- 4 Creation of mining concession in south zone of cultivated area.

- 5 Arable area to north of mining concession greatly enlarged by bringing more land up-slope into cultivation in unenclosed rigs bounded by dyke D. The shieling hut no 64 may date to this phase.
- 6 Mining activity by the Islay Lead Mining Co in the late 19th century with shafts being sunk in earlier workings.

These remains suggest an infield-outfield system superseding an earlier system with enclosed fields grouped on the lower slopes by the loch-side. In the new scheme the enclosed fields would have become the infield, and the outfield the area between dykes B and D. Dyke D would have been the head dyke for this phase. The possibility remains that there was an even earlier phase of infield-outfield farming with the infield contained by dyke A, and the outfield by dyke C.

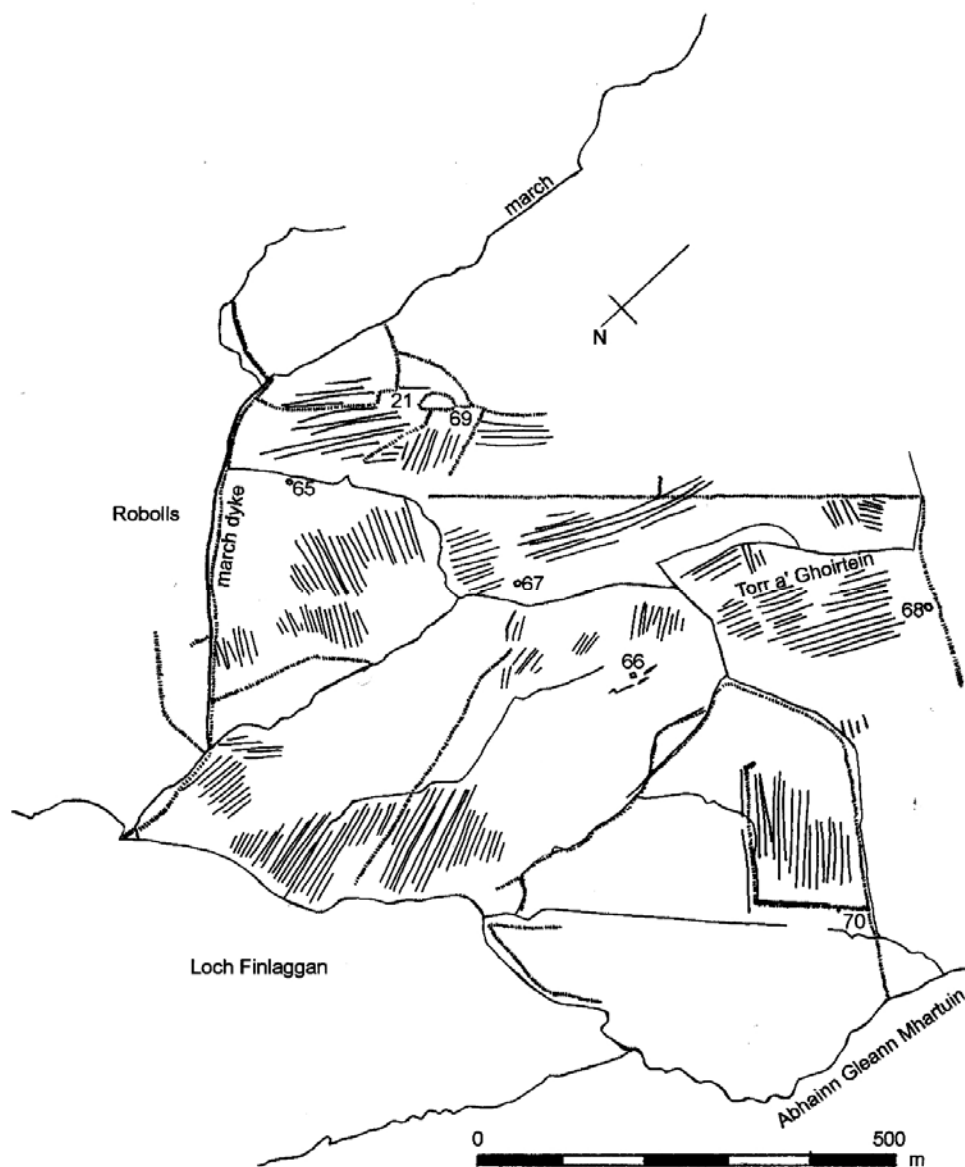

Illus 22 Field systems, Kepollsmore.

21. *FIELD SYSTEMS, KEPOLLSMORE (NR 386 666)*

The remains of a system of small irregularly shaped fields, with turf dykes enclosing rigs, can be traced around Dun Cheapasaidh Mor (no 69). Otherwise there are groups of rigs, including those on the low rise called Torr a' Ghoirtean (Gaelic for hill of the small garden), and others beside the loch-shore. These are not on good soil and may represent relatively recent – 18th- or 19th-century? – efforts to bring more land into cultivation with the application of lime. There are three kilns within this area (nos 65, 67, 68), at least two of which may have been for burning lead. This land would otherwise have been the 'heathy pasture' of Kepollsmore. It appears to have been sub-divided into larger enclosures, probably to demarcate the holdings of individual tenants.

PRE-IMPROVEMENT STRUCTURES AND SETTLEMENTS

Most of the structures and settlements identified in the study area appear to be of medieval or more recent date. They include huts, houses, enclosures and kilns.

HUTS

The huts are circular, oval or sub-rectangular, and are represented by the slumped remains of earth and stone or turf walls. Some are mounded quite high, suggesting rebuilding over many seasons. An engraving published by Pennant in 1774 shows such huts in use on Jura. Like many in the study area, these were being used as shielings, temporary shelters in the summer pastures where women and children went to look after the cattle away from the growing crops. Pennant's drawing makes it clear that the earth and turf was not load-bearing, but cladding for a framework of branches, like a basket or creel. He (1776, **) describes them as

'conic, and so low that entrance is forbidden, without
creeping through the little opening, which has no other door than a
faggot of birch twigs, placed there occasionally: they are
constructed of branches of trees, covered with sods; the
furniture is a bed of heath, placed on a bank of sod; two
blankets and a rug; some dairy vessels, and above, certain
pendent shelves made of basket work, to hold the cheese.'

HOUSES

There was little guidance available before commencing our fieldwork on how to identify and classify the ruined houses in the study area. Although most were probably mainly for human habitation no doubt they also include byres, stables and byres. Three possible mills are also identified (see nos 24, 44, 72). It seemed reasonably clear that most of the houses are no earlier than the 18th century, but Colin Sinclair's 1953 essay on Highland houses, in which he distinguished an Argyll type, labelled by him 'Dalriadic', did not prove to be an adequate guide. Our own work, first published in 2000 (Caldwell, McWee and Ruckley 2000, 62-65), suggested a typology of house forms including types A, B, C1, C2 and D. We present this here again in a modified form excluding type B, which no longer appears to be distinctive.

Type A houses

These are houses of turf, dry stone or other construction, often with opposed entrances in their long sides. They are normally oval, barrel-shaped or rectangular in plan. The rectangular ones usually have rounded corners. Our excavations on Eilean Mor have demonstrated that these can date to the Medieval Period and the 16th century. The difference between huts and type A houses is one of size, not easy to define since it is difficult to take definitive measurements from their slumped remains. Generally the houses have a length of 8m or more whereas the huts are rarely more than about 6m. Type A houses with turf walls probably had a framework of wattles. Such houses are often now called creel houses.

Type C houses

These are dry stone or clay-bonded rectangular houses. They are the houses that are found in settlements like Sean-ghairt, occupied in the 18th and early 19th century. Two sub-types can be distinguished:

C1: single chambered houses, often with opposed entrances in their long sides.

C2: two- or three-roomed houses.

Some form the core of larger complexes that have had other dwellings, barns or byres added, forming longer rectangular houses. Two other features, particularly of type C houses, which appear to be of typological, if not chronological, significance should be noted here - firstly the relative width of the structures and secondly whether they are largely constructed of field stones or quarried material. Gailey (1962, 170) has suggested that there may be a tendency for earlier dry stone houses to be narrower than later ones, since their builders may have been slow to take advantage of the relative ease of spanning wider spaces from load bearing walls. The use of quarried stone suggests professional in-put, and perhaps the involvement of landowners in

introducing improvements. In multi-phase structures walls of quarried stone are sometimes built on to structures made from field stones, but apparently never *vice versa*.

Type D houses

These are lime-mortared houses with fireplaces in the gable walls. In the study area none of these houses are likely to be any earlier in date than the 19th century, unless they are substantial modifications of earlier type C structures.

ENCLOSURES

The enclosures are small, of various shapes, and normally defined by earth banks. They may have served a variety of uses as stack yards, gardens or animal pens.

KILNS

The kilns in the study area are all ruined, the remains of small circular structures built of stone, about 4m to 6m in overall diameter. They are often built into the side of a bank, and probably had corbelled roofs of turf. They might either have been used for drying grain or burning lime for use as a fertiliser. In most cases there is not enough surface evidence to indicate which, and as yet, none have been excavated.

Corn-drying kilns did not have to be heated to a particularly high temperature, but there was a need to keep the fire well clear of the grain to avoid any risk of combustion. Kilns of this type, therefore, should be expected to have had flues for conducting hot air from an external hearth. Kilns for burning lime had to be fired to much higher temperatures and this may have been achieved by layering crushed limestone and peat in the kiln chamber. The burnt lime and ash could then be raked out through an opening at the kiln base.

22. SETTLEMENT, DRUIM A' CHÙIRN, SEAN-GHAIRT (NR 373 666)

This ruined settlement is situated about one third of a mile to the N of Ballimartin farm steading and about the same distance SW of the bottom end of Loch Finlaggan. The name Druim a'Chùirn, Gaelic for ridge of the cairn, is taken from the first edition Ordnance Survey map. There is now no trace of a cairn, the existence of which may also be reflected in the name of a ruined house, Carn mhic-fhearguis, nearby at NR 373 674 on the farm of Ballachlaven. Druim a'Chùirn appears to be the place called Shennyart (Sean-ghairt), represented by a house symbol, on Stephen McDougall's mid 18th-century map of Islay. The houses are

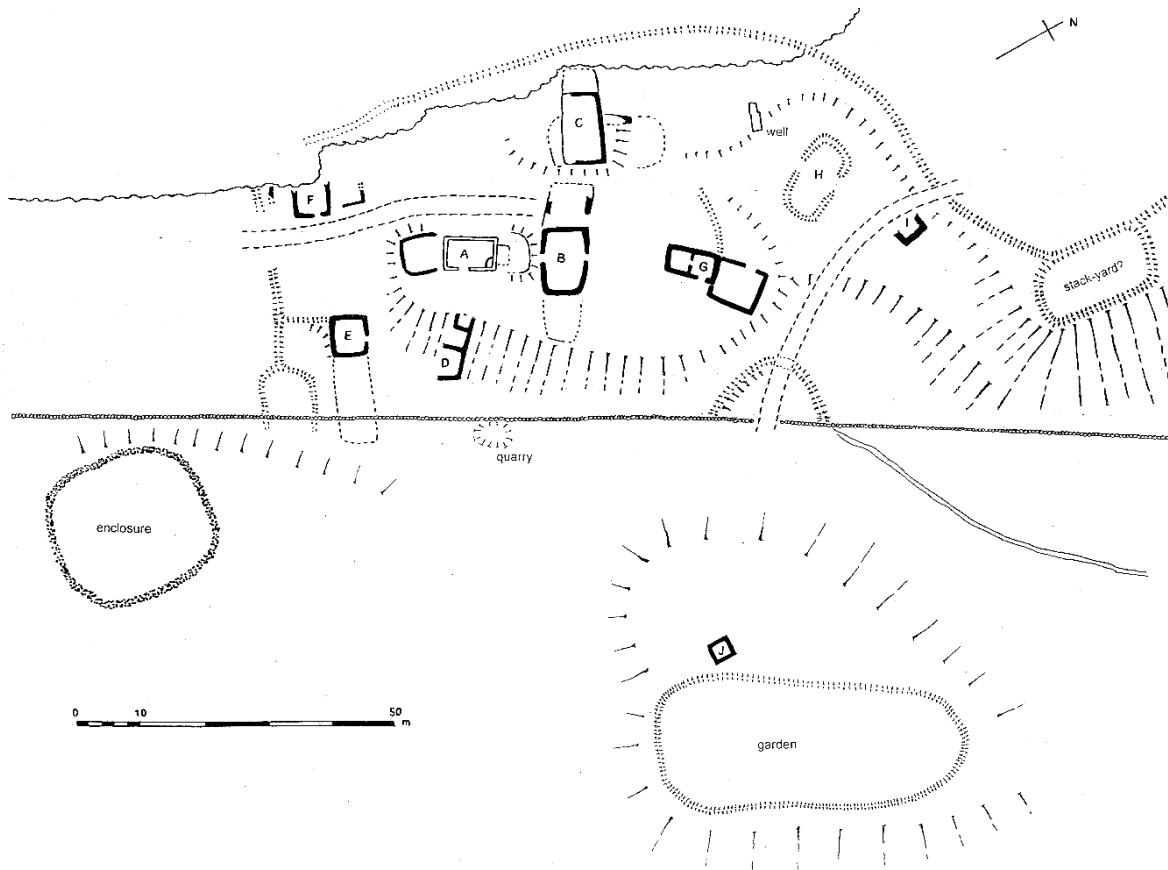

Illus 23 Druim a'Chuirn.

grouped on a series of terraces between a rocky slope to the W and a dry stone dyke to the E forming the boundary of a field of improved ground, formerly cultivated but now under grass. The dyke may date to c1833/34 because the Islay Estate rental for that year records that the farmer of Ballimartin and half Seanghairt was then paying interest on a loan for stone dykes. It has obviously truncated some of the remains of the settlement, and ploughing may have removed traces of other houses. The remains of at least 11 houses have been recognised, including one type D (house A) and one type A (house H). All or most of the rest are type C.

The only structure with upstanding walls is house A, a small rectangular cottage, 8.37m by 5.3m overall, occupied into the 20th century (information from Mathew MacMillan, the farmer of Ballimartin). Its walls are a mixture of local quarried material and field stones - limestone and dolerite, with some quartzite and dolostone - held in lime mortar. It has a cement floor, and fragments of corrugated iron in the debris inside are presumably remains of its last roof. In the NE corner there is a crudely constructed pen or shooting butt made from stones collapsed from the adjacent gable.

The S gable is near complete and appears to incorporate an earlier, narrower one, about 3m wide. Foundations against the N gable may also belong to this earlier structure. To the N and S of structure A are yet more grass-covered foundations, those to the S perhaps being the ruins of a small yard or garden belonging to the earlier house.

Immediately to the N of A and orientated at right angles to it are the grass covered foundations of house B with an overall size of 16.3m by 6.8m. It had two rooms, one with opposed entrances. Tenuous wall lines to the E are probably remains of an earlier structure. Structure C, about 15m by 7m, lying to the W of B and on the same alignment, also appears to overlie an earlier structure. C consisted of two rooms, a main one, and a smaller one, the end of which is cut into the rocky slope.

To the SE of house A are the remains of houses D and E, both on lower ground. D is partially buried by slope-wash, but at least part of it appears to have been a relatively narrow structure, 3.7m wide with walls including large field stones. E is represented by the foundations of a small squarish structure, but was probably originally a longer house, 17m by 6m. To the S of it are earth dykes forming small yards and a boundary to the settlement. A track from Ballimartin runs past the foundations of structure F, possibly a three-roomed structure, placed just inside the boundary dyke and below the rocky slope.

House G consists of the foundations of a small two-roomed house, 9m by 4.7m, with attached yard, lying on a gentle slope to the N of house B. To the NW of it is a well, now represented by a concrete structure with a large cast iron boiler beside it for cattle to drink from. Structure H, beside the well, is represented by low earth banks, forming a sub-rectangular shape, 14m by 8m. It had opposed entrances. House I, only 5m wide, has been truncated by a recent track.

On a higher piece of ground to the N of the houses is a small enclosure which perhaps served as a stack-yard. It is attached to an earth, or earth and stone, dyke which curves round the W of the houses and continues northwards, forming part of the head dyke on the W side of Loch Finlaggan.

The dry stone dyke marks the line of the old road around the W side of Loch Finlaggan. On a piece of higher ground in the field to the E of it are traces of at least one small stone-walled house (J), 3.6m by 3.7m, with a nearby garden. On

another low, rocky knoll to the SW is a sub-circular enclosure, about 22m by 25m, defined by a low turf-covered rubble bank. This is clearly not a garden since the interior is rocky with no depth of soil.

It is evident that there is more than one phase of occupation represented in the remains at Druim a'Chùirn. In typological terms the earliest house appears to be structure H. It would have been followed by the small narrow houses represented by G, I, probably D, and the earlier version of house A. Structures B, C, E, and probably F belong to a third phase, with last of all, the remodelled structure A. This latter building, along with house E and the small enclosure to the S of it backed by the dry stone wall, are the only structures shown on the plan of Ballimartin Fasmr made in the 1830s.

The enclosure in the field the other side of the dry stone dyke may be earliest structure of all. It is possibly of prehistoric or medieval origin, perhaps a palisaded enclosure providing some measure of defence to a nucleus of houses.

23. *SETTLEMENT*, (NORTH) SEAN-GHAIRT (NR 382 677)

The substantial remains of this ruined settlement lie on a broad terrace at a height of over 20m above Loch Finlaggan and about 150m to the E of it. The ruins, with a further group to the S, are known collectively as Sean-ghairt, but for ease of reference here the two clusters are distinguished as North and South Sean-ghairt. At N Sean-ghairt 10 houses have been identified, all of type C.



North Sean-ghairt

The houses and yards of the settlement are all built of local stone, including field stones and quarried material, mainly quartzite with lesser proportions of dolerite and limestone. The upstanding walls are of random rubble construction, sometimes with large, roughly rectangular, blocks positioned as door-jambes and quoins. In general the material used is sub-angular, quarried and split into roughly shaped rectangular blocks. Traces of clay mortar survive, especially in buildings A, B, C and I. In the W gable of house A a broken quern stone has been detected. There are no traces of roofing, presumably turf and thatch, associated with any building.

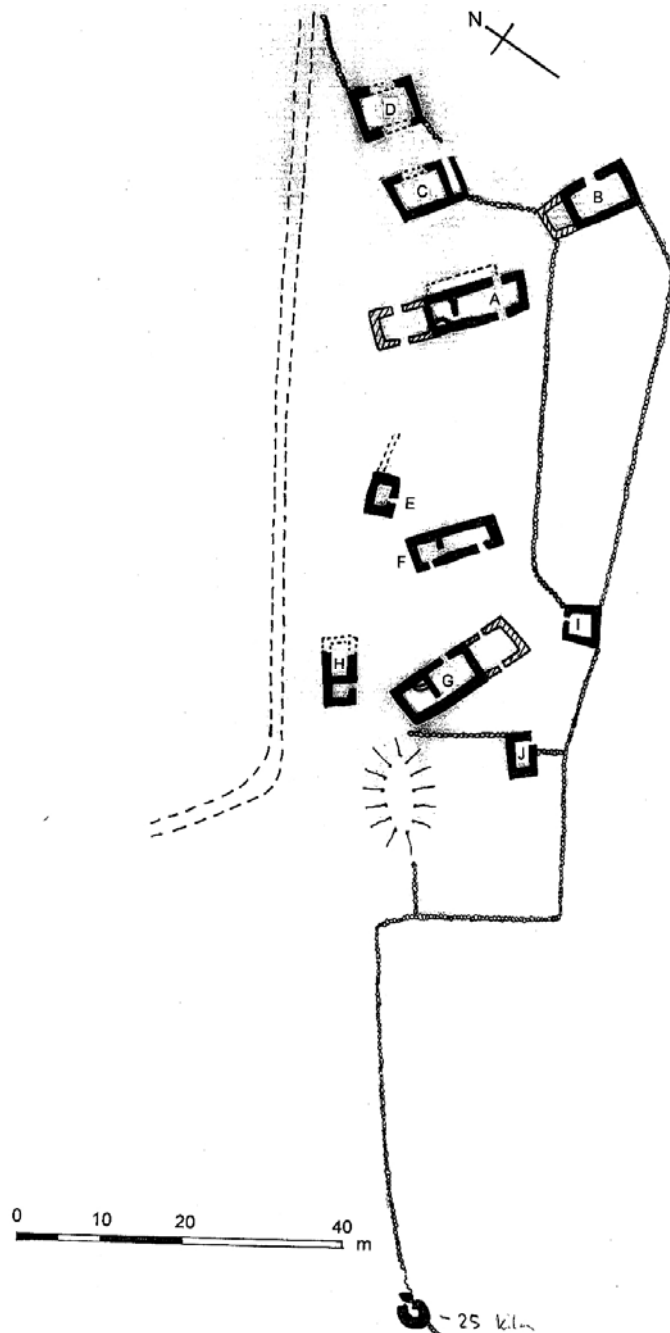

Illus 24 North Sean-ghairt.

There are the remains of ten buildings, A-J, and two yards or enclosures, lying adjacent to the old road up the W side of Loch Finlaggan. The yards are both enclosed by dry-stone dykes, and the larger of the two may have been kept in repair long after the abandonment of the settlement for use as a stack-yard or for animals. There are the foundations of two small buildings, I and J, attached to these yards, but both entered from outside of them. There are also the remains of a more substantial house (B) at the end of the larger enclosure. The main house is 9.5m by 5.5m and is entered from outside the yard. A smaller extension has been added at one end.

The main surviving house at North Sean-ghairt is structure A, still with walls and gables largely upstanding. It consists of an original unit with opposed entrances to which a larger extension has been added at the down-slope end, giving the structure a total length of 19m. The addition is divided into two rooms, a larger one with opposed entrances with a smaller one entered off it. A low platform along the exterior of its north wall might represent the remains of an earlier structure. There is a small secondary pen or shooting butt constructed in an internal corner.

The other main house in the cluster is G, with a total length of about 16.5m, not so well preserved as A. It also is composed of three rooms though here the two-roomed structure is the original structure, with a smaller building with opposed entrances joined on at the down-slope end. The ruins of A also contain a small shooting-butt or pen.

The other buildings at North Sean-ghairt are represented by foundations, some of them covered by turf. C and D are two adjacent cottages while F is a two-roomed house, perhaps all of one build. H and E are notably narrower than the other houses, 4m as against about 5m or 6m. Unlike the other houses in the cluster they are aligned with the contours and not across them.

24. *SETTLEMENT*, (SOUTH) SEAN-GHAIRT (NR 380 674)

This ruined settlement lies some 200m to the SW of North Sean-Ghairt on the same broad terrace overlooking Loch Finlaggan. The walling of structures here is generally similar to North Sean-ghairt, but there is a higher proportion of field stones, mostly quartzites, limestones, dolostone and dolerite, with clay mortar evident in house K. It and structure O have several poorly dressed stones.

South Sean-ghairt consists of the remains of two yards and seven type C houses, mostly built broad side to the slope. One of the yards has a circular patch of small stones in it, which might possibly be the remains of a stack stance. A small burn flows down beside the houses and the remains of a small house (N), cut into the slope beside it, might be a clack-mill.

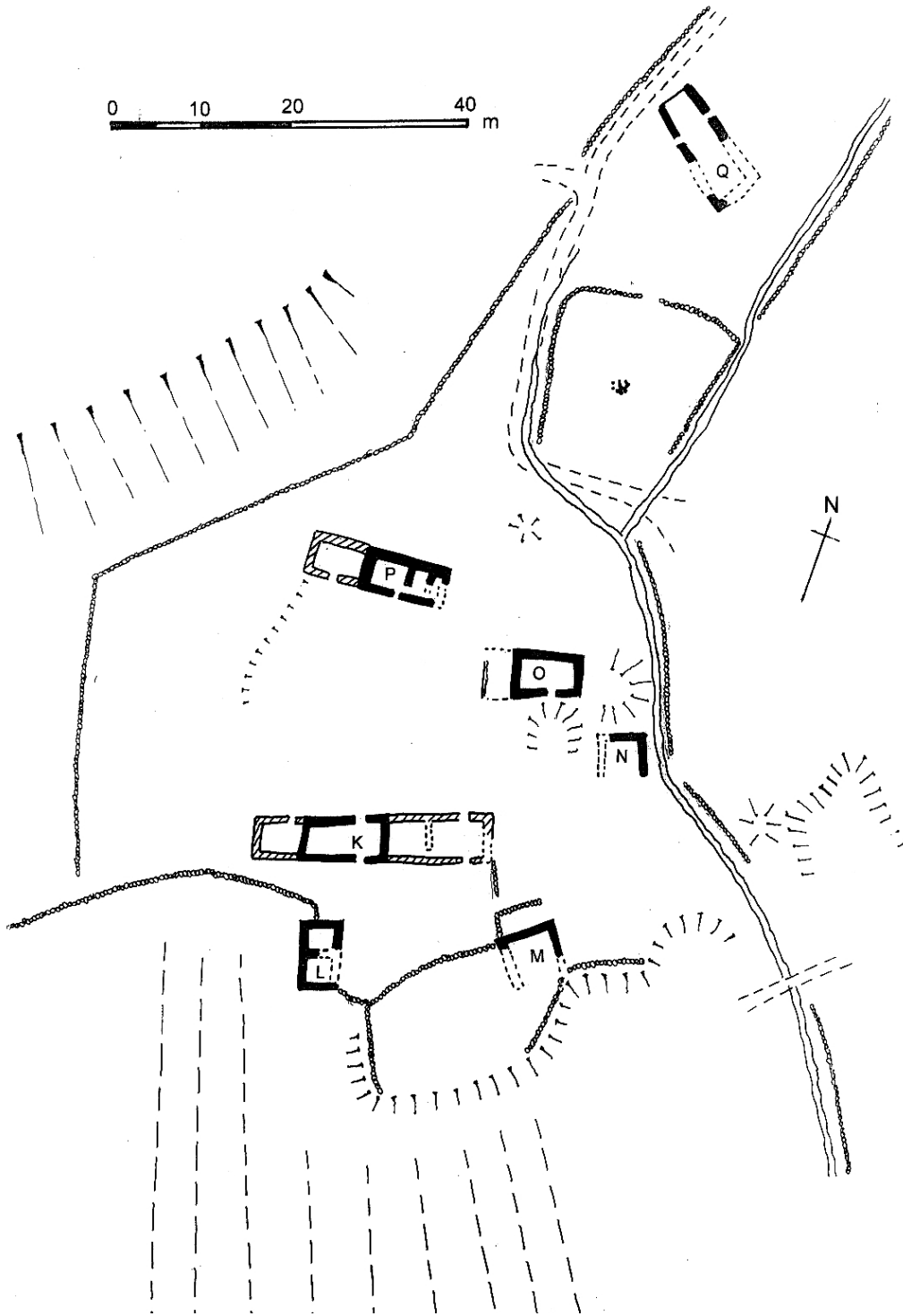

Illus 25 South Sean-ghairt

The largest structure is K, with a total length of about 27.5m, and it is the only one with walls surviving to any significant height. One of its gables is still about 1.3m high. The core of A is a house with opposed entrances, with at one end a smaller addition, and at the other an extension similar to house A at North Sean-ghairt. It has a larger room with opposed entrances with a smaller room entered off it. The end gable of this structure has a blocked doorway with traces of lime mortar in its stone work.

Smaller in size is structure P, also divided into four rooms, though here the original building has three rooms *en suite*, with a smaller addition at one end. Building O has two rooms, the smaller, presumably a byre, with a drain running through it. It is lined with stone slabs with no trace of any capstones. Building Q has its west gable wall cut out of a rock outcrop.

25. KILN, SEAN-GHAIRT (NR 381 676)

Midway between the N and S clusters of houses there is an outcrop of rock with a small circular kiln cut into it. There are traces of a sill stone, and a lintel collapsed *in situ*. It was probably for corn-drying.

26. HUTS, SEAN-GHAIRT (NR 378 678)

The slumped turf remains of two huts are positioned on a terrace at a height of about 150m below the summit of Cnoc an Tighe and between the head dyke and the dyke defining the boundary with Ballachlaven. One is about 5m in diameter, the other 5.5m by 8.5m, and appears to partially overlie a smaller, earlier hut.

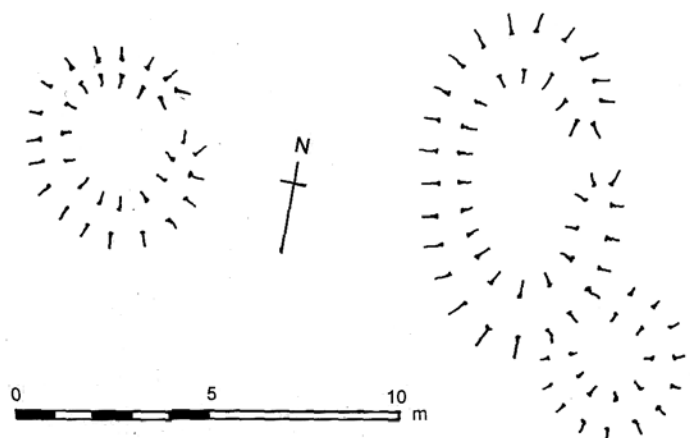

Illus 26 shieling huts (no 26).

27. HUTS, SEAN-GHAIRT (NR 380 680)

A group of four circular or oval turf huts arranged in a line on a sheltered terrace of Cnoc an Tighe above the Sean-ghairt head dyke, at a height of about 150m above sea level. The one furthest to the W partially overlies an earlier hut. The easternmost one is mounded high on the debris of its predecessors.

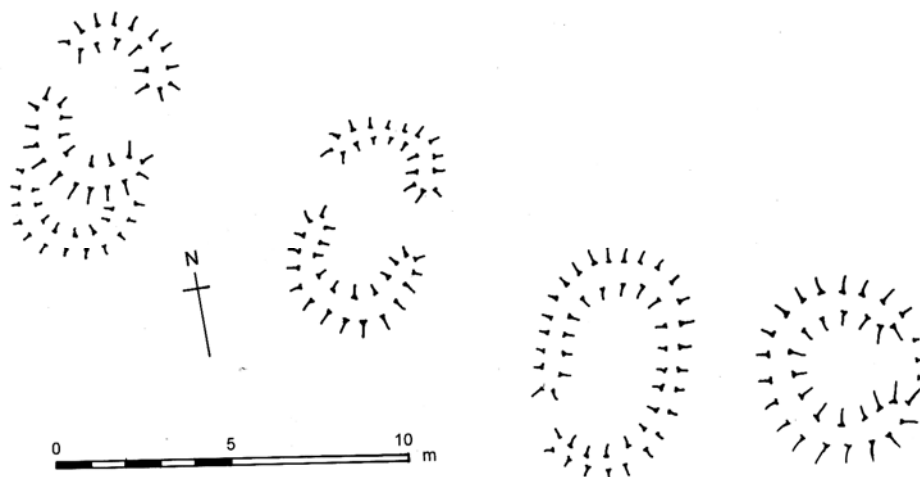

Illus 27 shieling huts (no 27).

28. HARBOUR, SEAN-GHAIRT (NR 385 678)

To the NE of North Sean-ghairt are the remains of a jetty, of boulders, alongside a small sheltered bay, bounded by another shorter jetty at a distance of about 8.5m. The area between has been cleared of stones, perhaps those in a heap a few metres to the SW.

29. KILN, SEAN-GHAIRT (NR 384 680)

A small circular kiln overgrown with grass, perhaps complete, collapsed *in situ*. It is about 4.35m in diameter and is sited in a field of rigs (see no 16 above). There are no signs of a flue.

30. KILN, SEAN-GHAIRT (NR 386 680)

The circular, stone foundations of a kiln by the shore of the loch near the boundary dyke with Portaneilean. It is 3.8m in overall diameter with an opening for a flue or rake-hole facing E. Its lintel is collapsed in place.

31. *HOUSE, AIRIGH IAIN MHARTUIN, PORTANEILEAN (NR 381 687)*

On a level area at the apex where two small tributaries of the Allt a' Ghoirtean join, below the brow of Cnoc na Cubhaig (Gaelic, hill of the cuckoo), but now in a clearing in a conifer plantation. It is a long type C2 house, about 23.8m by 6.3m overall, divided into three chambers. The middle, probably the dwelling, has opposed entrances. One end chamber has been subdivided by a secondary wall, and the other has had a little pen or shooting butt built in its corner after the house fell into ruin. It is of dry stone construction, using local, mostly quarried, stone. Much of the walling stands almost to full height but there is no evidence for windows. The house was abandoned prior to 1878. The blocking of all but one of the external entrances may have been done after it was roofless so it could be used as a sheepfold. The name is Gaelic for the shieling of John or Ian Martin, and the house no doubt replaces earlier shieling huts. The confluence of two streams like this is a typical shieling site on Islay, for example on the Allt na Tri-dail (Avenvogie) at NR 372 560) and on a tributary of the Abhainn Gleann Logain at NR 421 628.

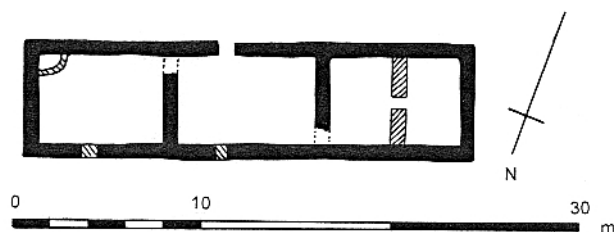

Illus 28 Airigh Iain Mhartuin.

32. *HOUSE, AN LEACANN, PORTANEILEAN (NR 383 690)*

On a level piece of ground, now within a conifer plantation, above the Allt a' Ghoirtean, probably part of the holding of Goirtean Chailean (see nos 17 and 33). A small ruined rectangular house of type C, about 5.3m by 6.8m, its walls largely upstanding, except that one gable has been collapsed to provide material for a small shooting butt. The walls are of dry stone construction using locally quarried quartzites and Port Askaig tillite. It has had a small attached garden.

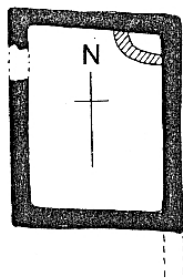

Illus 29 house at An Leacann.

33. *SETTLEMENT, GOIRTEAN CHAILEAN, PORTANEILEAN (NR 384 688)*

These ruined and overgrown type C houses are now covered with the conifers of a forestry plantation. They lie on a level platform immediately at the bottom of a steep slope crowned with a mature ash tree. The ruins of four houses are traceable, all of dry stone construction, mostly quarried blocks of quartzite, but also including large blocks of dolerite for quoins. The most substantial house, labelled A, has opposed entrances in its long sides, and an added chamber at one end. House B also appears to have had two chambers. Houses D and C were simple squairish structures, D set on the line of a turf boundary dyke, perhaps forming a head dyke for the associated field system (no17). See also the house, no 32. Goirtean Chailean is Gaelic for Colin's garden, and was already abandoned by 1878.

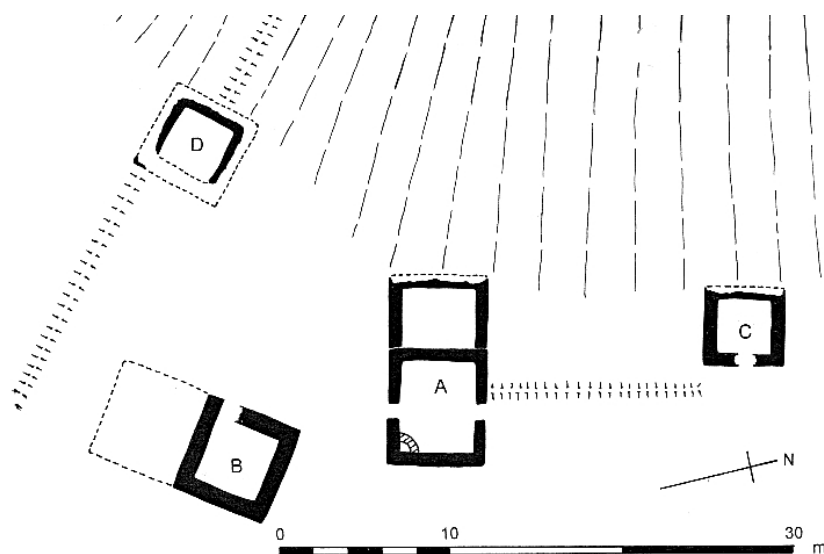

Illus 30 Goirtean Chailean.

34. *HOUSE, AIRIGH NAN CAISTEAL, PORTANEILEAN (NR 377 700)*

The name is Gaelic for the shieling of the castle and the name has also been applied to a nearby loch and a small glen with a burn. The type C house, now hemmed in by trees, was built on open moorland at a height of about 170m above sea level. It is a small rectangular dry stone structure, built of field stones, mostly quartzite. It measures 7.0m by 5.0m overall and is now largely ruinous and overgrown. A mound at one end may be the remains of earlier turf huts. Unlike other shieling sites in the survey area, Airigh nan Caisteal is some distance beyond the head dyke. That, and the name which may relate it to the castle at Finlaggan, suggest that its use may go back to medieval times.

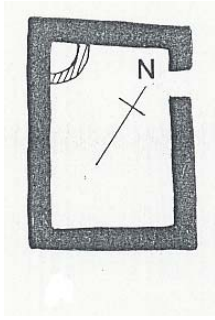

Illus 31 Airigh nan Caisteal.

35. *SETTLEMENT, AIRIGH NAN CLACH, PORTANEILEAN (NR 386 708)*

In a bend of the Allt a' Chromain are the ruins of a small type C dry stone rectangular house, about 5m by 7m overall. Its walls, mostly of quarried blocks of quartzite, have been largely rebuilt to form an oval enclosure, perhaps for lambing or else as a shooting butt. Nearby are the foundations of another ruined house about 6m by 5m. Round about them, on a level shoulder of ground, is an area of green grass now infested with bracken, and dotted with small clearance cairns – obvious signs that the ground here has been cultivated. Neither house appear on the OS map of 1878, and the more complete one only on later editions. It is possible that this is the settlement of Lechacruath recorded in the 1861 census.

The Allt a' Chromain formed the march between Portaneilean and Balulive. Airigh nan Clach (Gaelic, shieling of the stones) is defined in the Ordnance Survey Name Book as a tract of heathy pasture, 480 acres in extent, bounded on the N by the Allt Loch nan Eun, on the W by Carn a' Choinnleir and Carn Meadhonach, and extending on the E to within a short distance of Crò Earraich, and on the S to a short distance S of the Allt a' Chromain. It is now sandwiched between two large conifer plantations. Most of Airigh nan Clach fell within the boundaries of Balulive, and there is a shieling mound on the Balulive part at NR 389 713 with the ruins of a small rectangular house nearby. There is also a burnt mound on a tributary of the Allt a' Chròth Earraich at NR 389 711.

36. *HOUSE, CACHLAIDH CHREAGACH, PORTANEILEAN (NR 389 700)*

The overgrown ruins of a small rectangular type C house on a slope above a tributary of the Finlaggan River. It is of dry stone construction, mostly quarried quartzite blocks. It is now in a clearing in a conifer plantation and contains a small shooting butt. The name is Gaelic for rocky gate.

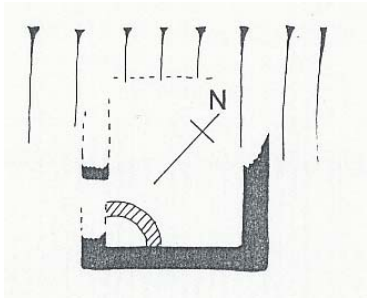

Illus 32 Cachlaidh Chreagach.

37. SETTLEMENT, CUL A' BHAILE, PORTANEILEAN (NR 396 690)

There are the grass-covered foundations of two type C houses on either side of the track from Mulreesh to Cachlaidh Chreagach, and a few metres to the NE a level enclosure, 14m square overall, defined by an earth bank. The house to the S, about 18.3m by 6.3m, appears to have been divided into three chambers, the middle one with opposed entrances, and has had a garden to the S. The house to the N is shorter and broader, about 13.5m by 7m, and has two chambers, one with opposed entrances. At one end is a narrower third chamber, probably an addition. The name Cul a' Bhaile does not appear on any maps but was given by a previous tenant of Finlaggan Farm. It is Gaelic for the back of the township, and must be the Backton of the 1861 Census.

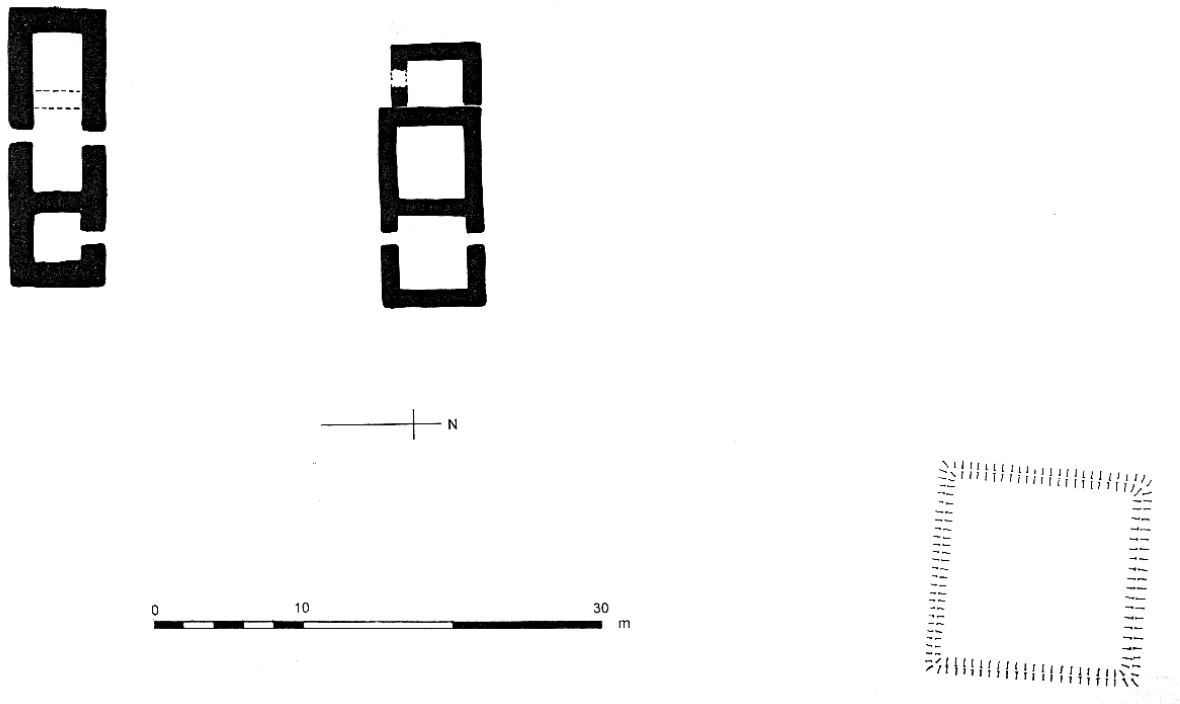

Illus 33 Cul a'Bhaile.

38. SETTLEMENT, RUDH' A' CHRÒCUIN, PORTANEILEAN (NR 386 681)

The ruins of two type A turf-walled houses on a terrace adjacent to the remains of a small jetty of boulders on the W shore of Loch Finlaggan. One house (A) is long and rectangular, 14m by 5m, positioned end-on to the loch. Gaps in its walls may represent the positions of two sets of opposed entrances but they also coincide with tracks worn by humans and animals. The other house (B) is shorter, with rounded corners, and side-on to the loch. It measures 7.5m by 5.5m overall and appears to have an entrance in the side facing the water, and, less probably, another in its W end. In 1994 limited excavation was initiated on the smaller of the houses by the Time Team, and completed by us:

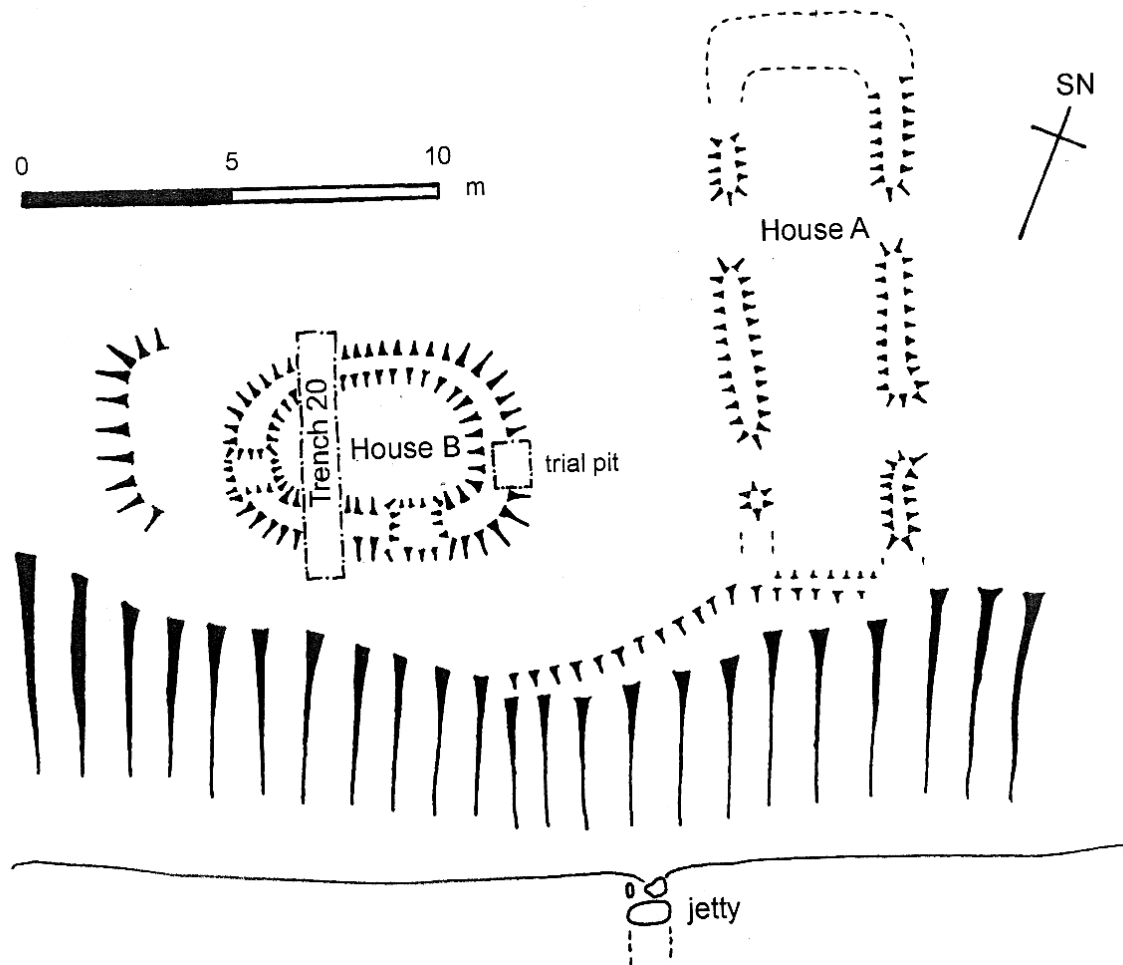

Illus 34 Rudh' a' Chrocuin.

Trench 20

A small trench, about 1 by 6m, positioned to cross the structure from side to side, avoiding the possible entrance in the S wall. A small trial pit, about 1m by 1.2m, was later partially excavated in one of the end walls.

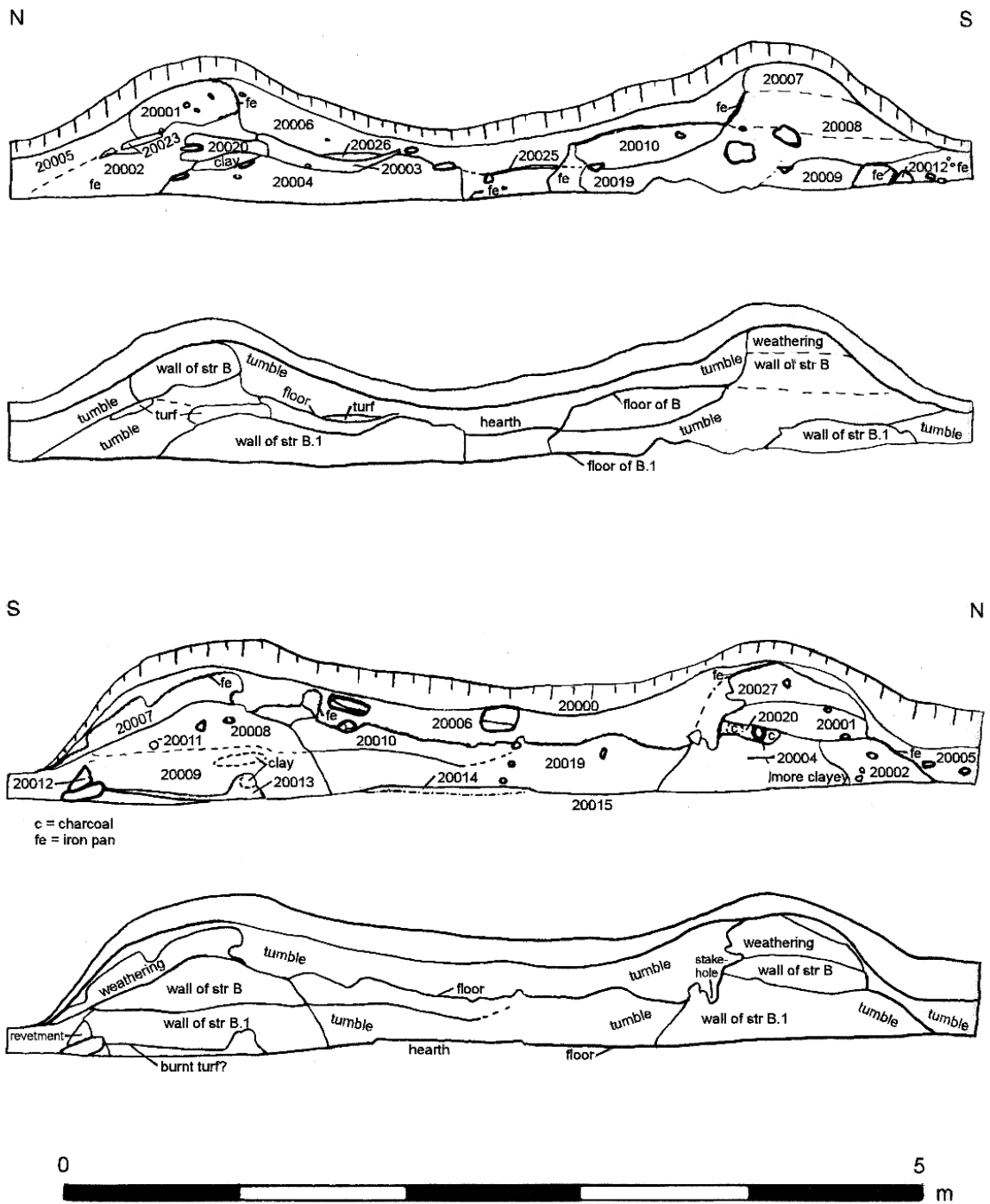

Illus 35 Sections, with interpretative drawings, of both sides of trench 20.

The walls of this building had been constructed of turf, probably supported on a framework of wattles. The walls are now badly slumped and damaged by the formation of an iron pan and peaty soil. Only a few limited conclusions can be drawn from the area examined, including, firstly, that the wall remains which define house B

overlie an earlier structure (structure B.1). The remains of the walls [20001, 20008] of house B are of dark brown silty clay with peaty soil [20005, 20006] filling up the interior space and sloping down the outside. The E facing section of the trench possibly shows a stake-hole in the inner face of the N wall. To level up the interior and make a firm floor a thick layer of silty sand [20003, 20010] was laid down. A pit is evident in the W facing section, capped with a layer of charcoal [20025]. This is interpreted as a hearth.

Structure B was built on top of the collapsed and weathered walls of an earlier house, structure B.1. The time between the demise of B.1 and the erection of B was sufficient for the formation of a covering of turf, [20023, 20020, 20011], partially burnt, much of which was probably shovelled away in levelling the site for the new house. Hence the division between the freshly exposed S wall of B.1 and the debris from it [20009, 20019] and the new build of the wall of B [20008] laid on it, is not distinct in section. There are clues that B.1 had a different footprint from B. Firstly, the W facing section seems to cut along the E wall [20004] of this structure. Secondly, its W wall may be reflected by the edge of a terrace 2m to the W of B, allowing for a turf-walled house with rounded corners, of similar size to house B.

There is a patch of charcoal and ash [20013] under the S wall of B.1, perhaps from the burning of the grass and heather prior to construction of the house. The area within the walls was cleared down to a surface of natural silty sand [20015]. A shallow scoop, extending from the E facing balk into the trench, has peat ash and burning [20014] spreading out from it, and is interpreted as a central hearth.

No dating evidence was found for either structure B or B.1. It is thought likely that they date to the Medieval Period.

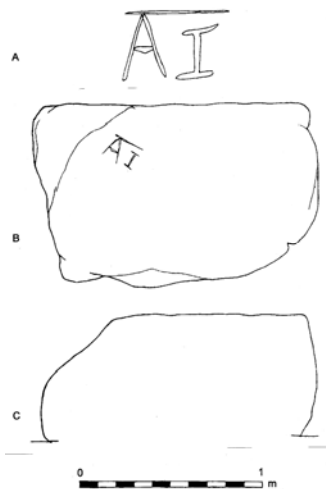

Illus 36 Stone inscribed with AI.

39. *INSCRIBED STONE, PORTANEILEAN* (NR 3874 6813)

A large rectangular boulder, a glacial erratic of meta-igneous rock, 1.45m by 0.96m, and 0.65m high, sitting on the W loch shore opposite Eilean Mor. Neatly incised on its top surface is AI. Both letters are Lombardic capitals, the A with a top- and a cross-bar, and are obviously medieval in form. The I is smaller than the A, suggesting it should be read as a 'one' rather than a letter. The inscription was only discovered in 1996.

40. *JETTY AND INSCRIBED STONE, PORTANEILEAN* (NR 3875 6819)

A small group of large stones opposite Eilean Mor, normally partially submerged in the water of the loch. They can reasonably be interpreted as 'the remains of a pier' reported in 1772 by the travel writer, Pennant (1776, 258), who was taken to Finlaggan by a local Laird, Campbell of Sunderland. He described how one of its stones was cut with 'A.II. or, *OEnéas* the second, one of the lords of the isles, in whose reign it was founded'. 'OEnéas the second' was Angus Og, the supporter of Robert Bruce.

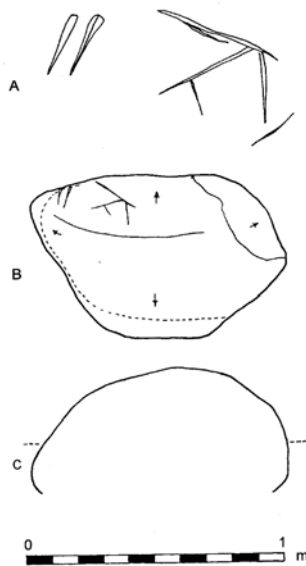

Illus 37 Stone inscribed with A.II.

The stone in question had dropped from sight since Pennant's day. Indeed, when the AI inscription (see above, no 39) was discovered in 1996 there seemed a real possibility that that was the stone seen by Pennant, and it had been turned into AII through some error. In the summer of 1997, however, when the water level in the loch was very low, the AII stone was re-discovered. It is a quartzite boulder, 1.02m by 0.67m, with a height of at least 0.48m, which would often be totally submerged in the water. The portion rising above the loch sediments is sub-oval in shape, but this may be giving a misleading impression of the size and outline of what could be a much

larger stone. The inscription is different in character from the AI, consisting of large, bold incisions, forming rather irregular letters. It actually reads IIA rather than AII, but it cannot be doubted that this is the stone Pennant saw. Pennant assumed the stone dated the jetty but we may suppose that the jetty is much later and the stone re-used.

41. *EILEAN MOR, PORTANEILEAN* (NR 388 681)

An island settlement with the ruins of a post-medieval township succeeding important medieval and earlier remains. See next chapter for a detailed description and account of the excavations.

42. *EILEAN NA COMHAIRLE, PORTANEILEAN* (NR 387 680)

An artificial island with a sequence of structures extending from prehistoric times to the Medieval Period. See next chapter for a detailed description and account of the excavations.

43. *HUT, PORTANEILEAN* (NR 388 683)

The collapsed turf remains of a small circular hut, about 5m in diameter, squeezed between the old road, bounded by a turf dyke, and the shore of the loch.

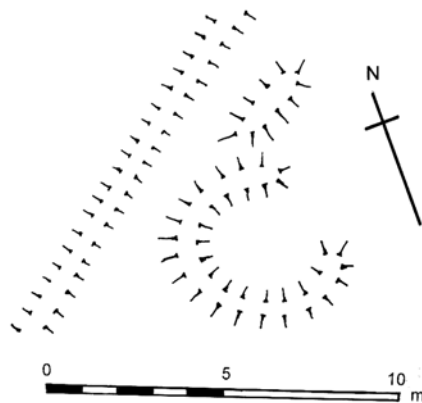

Illus 38 hut no 43.

44. *SETTLEMENT, PORTANEILEAN* (NR 389 683)

Several structures, including huts and at least one house, are concentrated in a small area at the N end of Loch Finlaggan, bounded by the Finlaggan River, another unnamed stream, and the old road up the W side of the loch. The ground

is now rough pasture, some of it very boggy. The thin peaty soil, however, shows signs of having been cultivated in the past in short rigs.

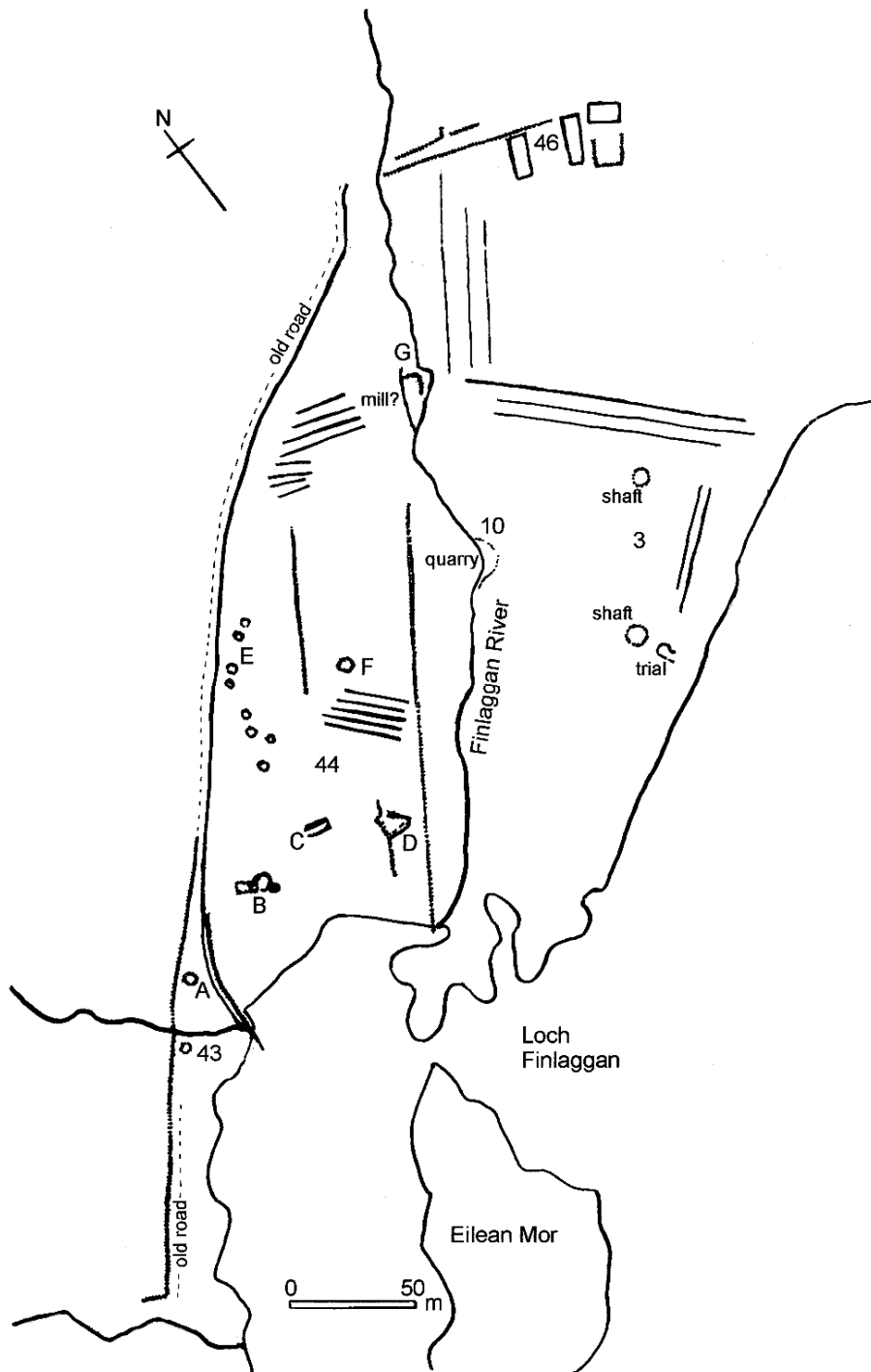

Illus 39 Settlement no 44.

It is not clear to what extent any of these structures are contemporary or represent a coherent, permanent settlement. Almost by definition, the huts indicate

temporary occupation. They may be the houses on the loch-side seen by Martin Martin (1994, 273) at the end of the 17th century and identified by him as those of the bodyguard of the Lords of the Isles. He may well have been right.

(A) A substantial turf covered mound near the loch shore adjacent to the old road from Sean-ghairt. It is about 10m in diameter and represents the accumulated ruins of a series of small huts. The collapsed walls of the most recent - either two small oval structures or one two-roomed house, are visible on top.

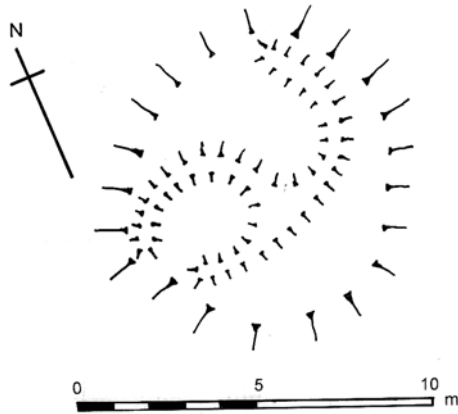

Illus 40 No 44 (A).

(B) A series of overlapping huts, not all contemporary, rather than a multi-roomed long house. They stand on a small heather covered knoll adjacent to the old road near the loch shore. There are two oval huts and two rectangular ones. The most substantial is the rectangular hut at the W end of the group, about 6.5m by 5.5m with opposed entrances in its longer sides. In 1992 it was proposed to undertake limited excavation on this cluster:

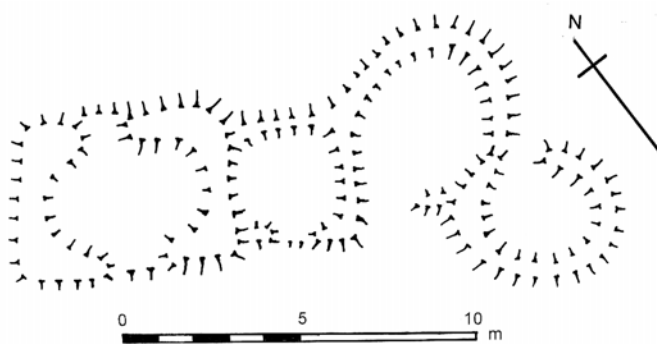

Illus 41 No 44 (B).

Trench 13

A start was made by laying out and de-turfing this trench, about 3m E-W by 8m N-S, positioned over the S wall of the westernmost hut. A limited amount of work in a

small area of the trench indicates that the hut wall contained no stone but consisted of turf, burnt when the house was destroyed. The wall was put down straight on top of a thin layer of peaty soil overlying the quartzite bedrock. The work came to a halt before it progressed any further due to lack of resources. There were no finds.

(C) A few metres to the E of A, the collapsed turf remains of a type A rectangular house about 9.5m by 6m with its entrance, untypically, in one of its short sides.

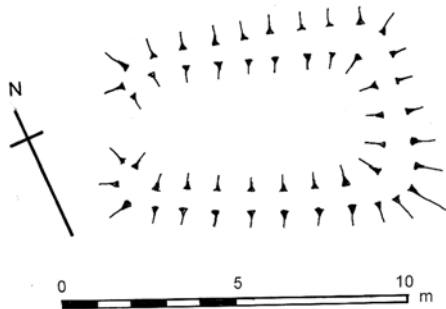

Illus 42 No 44 (C).

(D) A small D-shaped enclosure defined by a spreading stone and earth bank, enclosing an area about 6.5m by 10m. It was identified in 1878 by the Ordnance Survey as a burial-ground and is so listed by the RCAHMS (1984, no 379). It lies near the edge of the loch on the line of a later earth dyke.

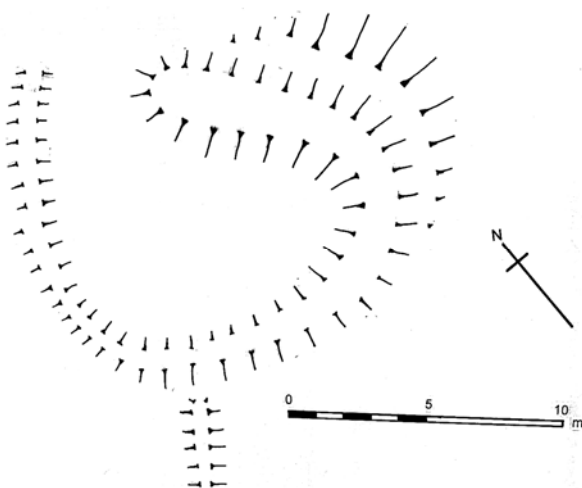

Illus 43 No 44 (D).

(E) A linear arrangement of at least eight small circular huts between the old road and a field dyke about 40m to the E.

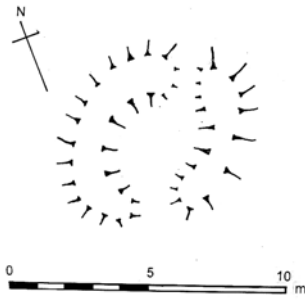

Illus 44 a turf hut, no 44 (F).

(F) The collapsed turf remains of a circular hut with an overall diameter of about 6.5m, partially overlying an earlier circular hut.

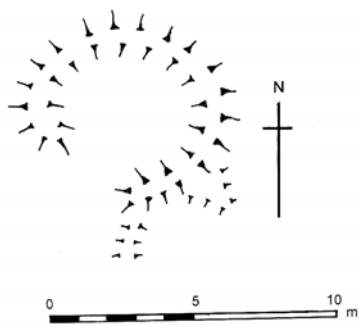

Illus 45 No 44 (F).



Illus 46 The site of a mill on the Finlaggan River.

(G) Mill? The evidence for a mill on the Finlaggan River is tenuous, but is supported by the results from a resistivity survey by Geophysical Surveys of Bradford for the *Time Team* in 1994. The site is a small level platform on the W side of the burn where it is confined by steep banks and flows quite swiftly towards the loch. There are no obvious signs of a building but there are the remains of a stone dam and traces of a leat behind it, now totally silted up. It can be seen in section in the bank of the burn. This supposed mill showed up in the geophysical survey as an area of high resistance, with the leat represented by a linear spread of low resistance adjacent to it.

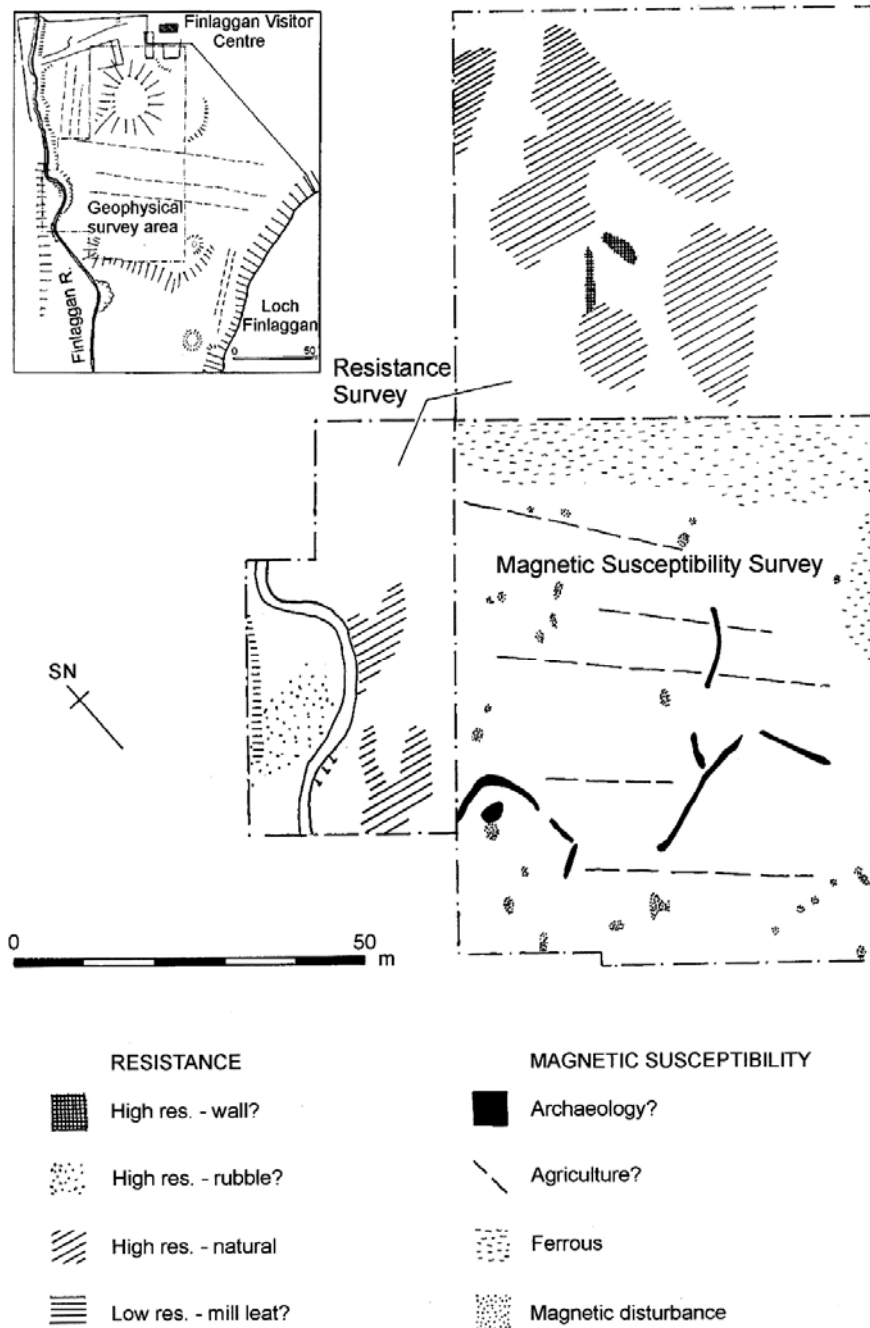

Illus 47 Geophysical surveys adjacent to Cnoc Seannda.

45. *HOUSE (?)*, *PORTANEILEAN* (NR 390 684)

Three sides of this possible, rectangular house are traceable in the magnetic susceptibility survey of the flat area to the SW of the mound at Cnoc Seannnda, carried out by Geophysical Surveys of Bradford in 1994. It appears to be about 20m by 12m with a central hearth. The ferrous disturbance nearby is manifestly due to strands of wire from an old fence.



Illus 48 Cnoc Seannnda.

46. *SETTLEMENT AND PREHISTORIC REMAINS*, *CNOC SEANNDA*, *PORTANEILEAN* (NR 391 684)

The mound at Cnoc Seannnda (next to the Finlaggan Visitor Centre) at the head of Loch Finlaggan is a prominent local landmark. It appears as a regular hemispherical mound with a base diameter of about 50m and a height of over 6m above the adjacent ground. There was never any doubt that it consisted of solid rock, metamorphic limestone with the strata on edge. Some of these can be seen breaking the surface of the grass, tending in a SW-NE direction (true orientation - not on the basis of the site grid used on the two islands). Its name means 'oldish knoll' in Gaelic.

Terraced into the N side of the mound and between it and the old road are the foundations of two type C long houses (A and B), orientated SW-NE and parallel to each other. Both appear to have been sub-divided into three chambers. House A was about 18m in overall length with a width of 5.25m. House B was almost 20m long and 5.25m wide. The N end walls of both houses bounded the old road, here a dirt track bordered by stone dykes, leading to a ford across the Finlaggan Burn and then southwards down the lochside.

A third house (C) at right angles to B, has been rebuilt to serve as the Finlaggan Visitor Centre. It is shown as a roofed building at a sharp bend in the old road on the Ordnance Survey Map of 1878 (there are no indications of houses A and B,

presumably by then reduced to their foundations). The Finlaggan Visitor Centre was a derelict cottage until extensively restored and remodelled in the 1980s for use by the Finlaggan Trust. It had lime mortared walls and a slate roof.

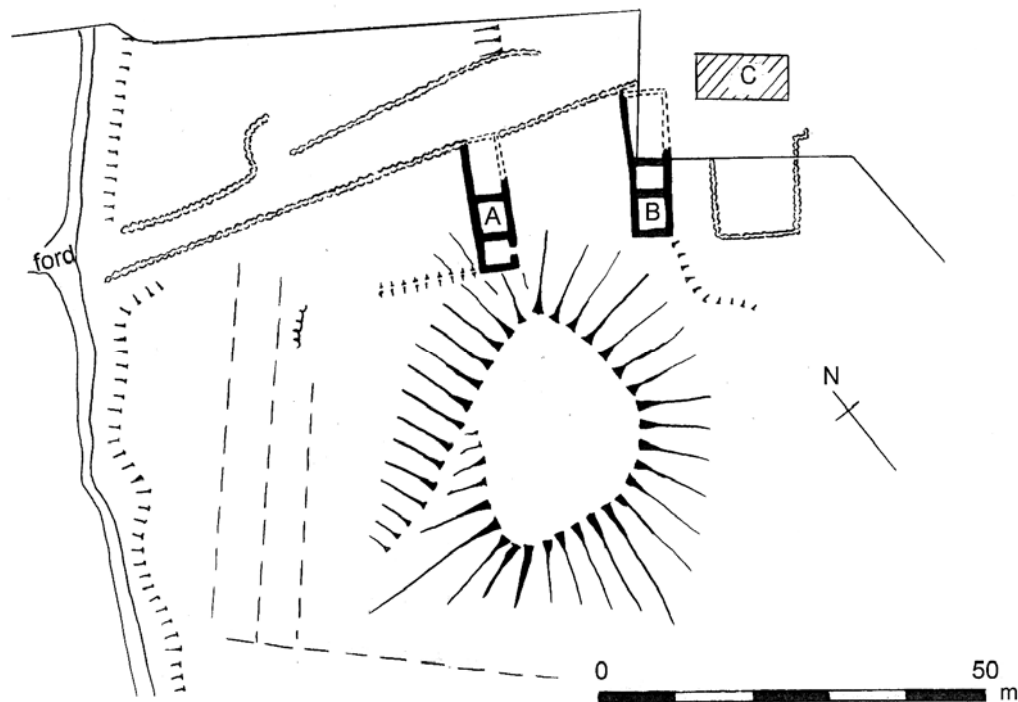

Illus 49 Plan of settlement at Cnoc Seannnda.

The mound also attracted attention because it was considered a possible site of the inauguration ceremonies for the Lords of the Isles. The idea that it was worthy of archaeological examination was presented to *Channel 4's Time Team* in 1994 and it undertook work over three days in June 1994, duly featured on the *Time Team* programme in January and October 1995.

Initial survey of the mound by a team from the Royal Commission on the Historical Monuments of England identified two adjacent, low humps on the summit of the mound running at right angles to the strike of the rock. The probability that at least one of these was the result of human intervention was reinforced by a resistivity survey carried out by Geophysical Surveys of Bradford. It picked up two patches of high resistance on top of the mound, one of which turned out to be the 'chamber'. The other may reflect the underlying geology rather than the kerb cairn. There was also a suggestion from the Royal Commission's work that there were traces of a low bank at the NE edge of the summit area. Two trenches were opened to explore these features:

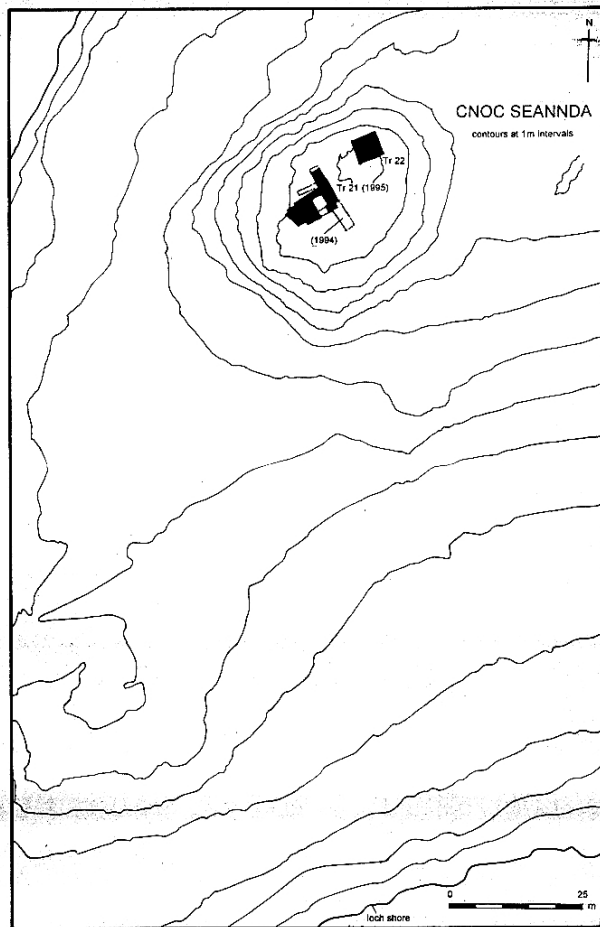

Illus 50 location plan for trenches 21 and 22.

Trenches 21 & 22

Trench 22 was 5m by 5m and positioned to the NE of the summit area. The removal of the turf and a very thin layer of topsoil revealed bedrock, the strata here twisting round and fortuitously giving the impression of a low bank. Trowelling of the topsoil produced a total of fourteen flints.

Trench 21 developed in shape as a reversed F with its main axis lying approximately NW-SE. Here was revealed a stone-lined chamber excavated into the bedrock. Spread around were numerous flints, identified as of mesolithic type, and a sondage into the deposits within the chamber led to the recovery of cattle bone. At this point it was decided to suspend excavation for 1994 and to leave a more thorough examination of these features for 1995.

In October 1995 the area of trench 21 containing the chamber was reopened and the trench extended to take in the adjacent hump identified in the survey of the mound.

This proved to represent the remains of a small kerb cairn. There may be at least one more such cairn conjoined to the west.

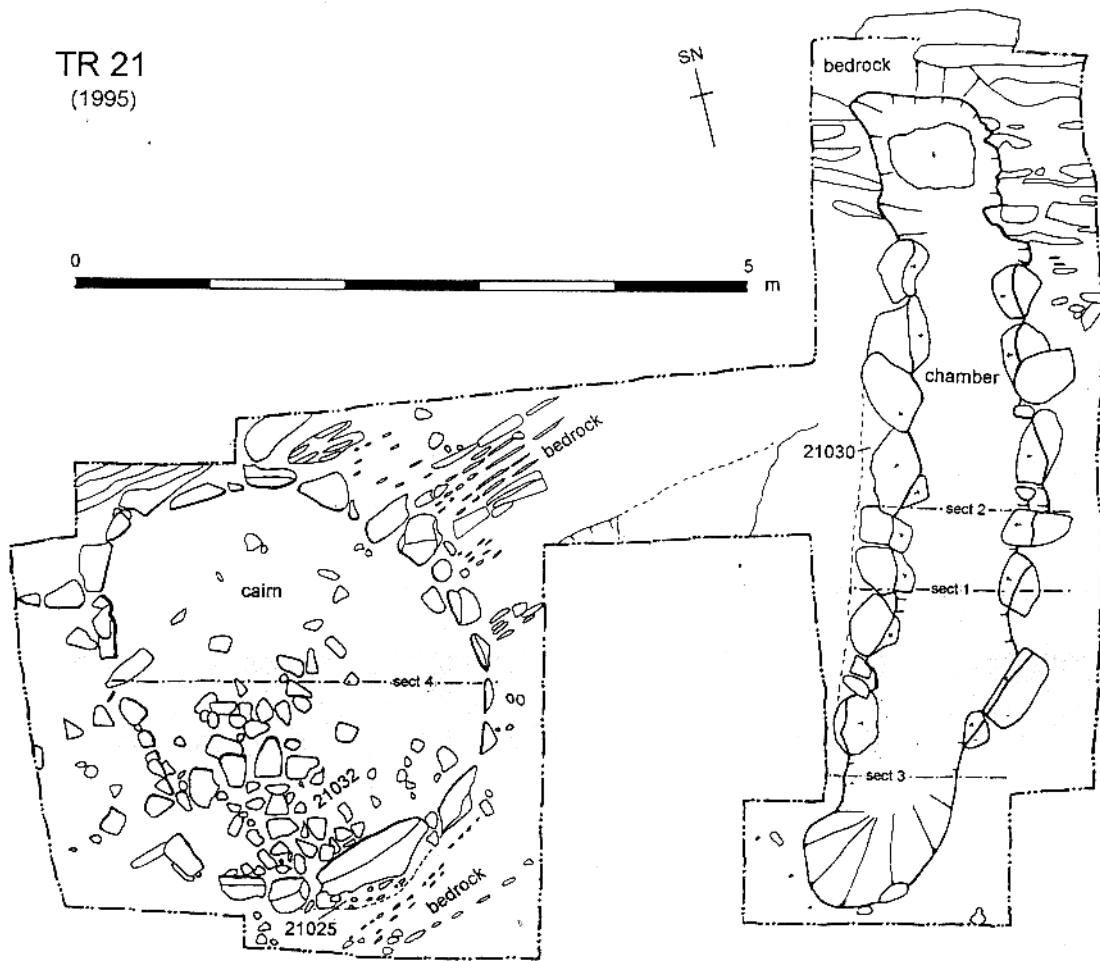

Illus 51 Plan of trench 21.

The natural stratigraphy on the top of the mound consists of a relatively thin deposit of topsoil and turf overlying the limestone bedrock. Over much of the area excavated in trench 21 there is a gravel spread [21014, 21007] sandwiched between the topsoil and bedrock. It contains flints, and is possibly the main source of the several hundred flints recovered from various deposits within the trench and identified as mesolithic (See below, report on lithics by K Hardy). The possibility was considered that this gravel spread might be a mesolithic deposit *in situ*, but it is stratigraphically later than the chamber and may rather be interpreted as material robbed from the cairn and spread around.

The cut for the chamber turned out to be banana-shaped, about 6m long and 1m deep. The actual chamber itself is only about 4m long and is not obviously curved. It

is lined on both sides by large boulders and slabs, some of them pieces of limestone prized from the bedrock. The two ends of the cut contain sandy silt and fragments of limestone [21018, 21037], representing the original backfill from when the chamber was built. Overlying this deposit in the N end is a large slab of limestone that may be the dislodged end piece of the chamber. There is no similar slab in the corresponding position at the S end of the chamber. The bottom of the chamber, and the gaps between the boulders and slabs have a deposit [21028, 21030] of silty clay with flakes of limestone, interpreted as silting.

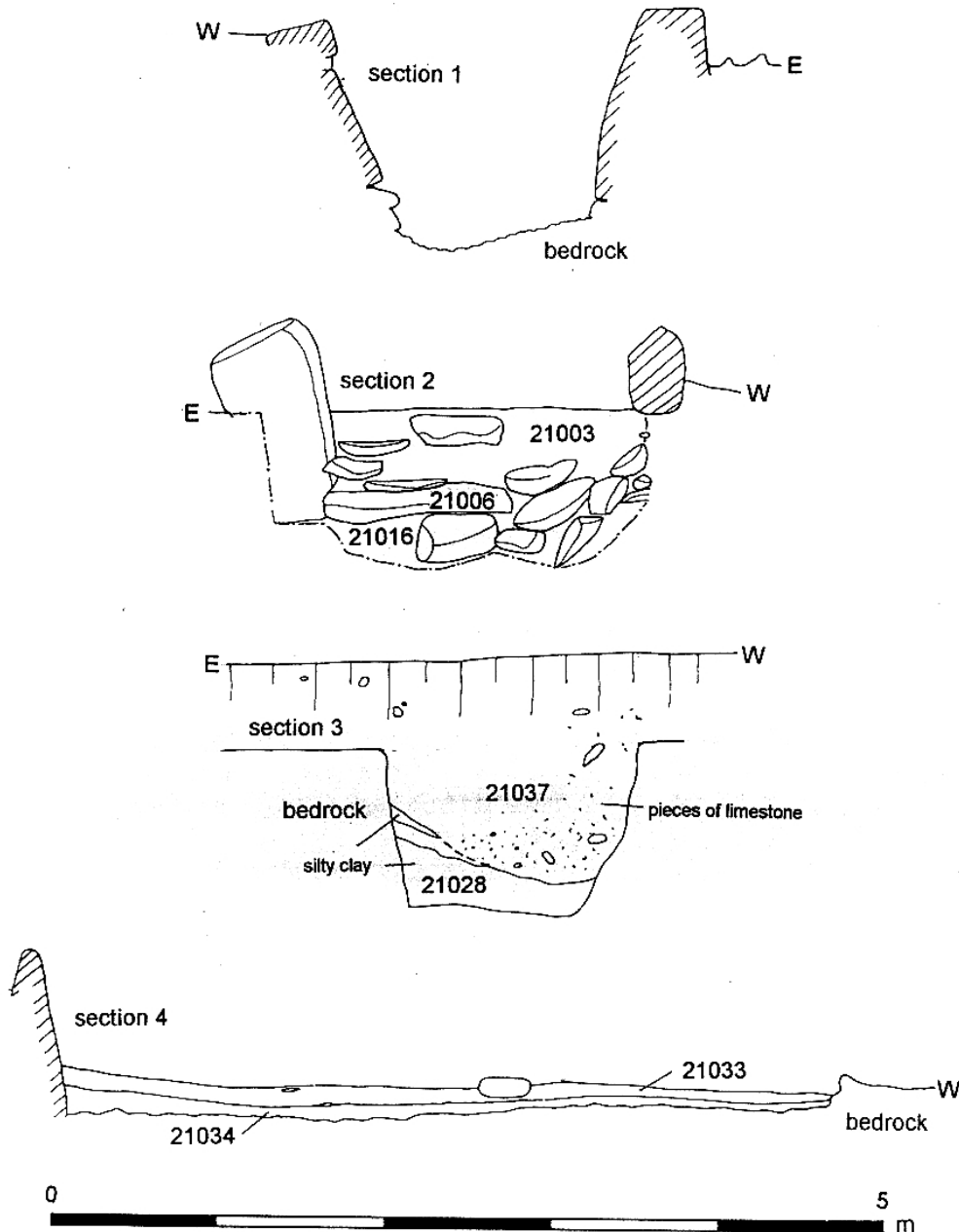

Illus 52 Trench 21 sections.

Under a build up of peaty soil [21003] the chamber contained deposits of rubble and clayey silt [21006, 21016], apparently material back-filled in antiquity when the structure was re-opened and robbed. The rubble included slabby pieces of limestone and quartzite, but none were big enough to be convincingly interpreted as the remains of lintel stones for the chamber. There were also several fragments of animal bone, including six identified pieces of cattle and one of red deer.

From the silt fill under the rubble was recovered a pierced bone disc (SF 21154), identified as an Iron Age piece, possibly a toy. It may date the robbing of the chamber. A flint barbed and tanged arrowhead of Bronze Age type (SF 21157) was found at the bottom of 21016 in the NW corner of the chamber. It is assumed to be all that remains of the original contents.

The small, denuded, kerb cairn has no sure stratigraphic relationship to the chamber, but if the arrowhead dates the latter, the cairn is likely to be later in date. It is D-shaped, about 3.5m by 2.8m, possibly with the kerb of another cairn springing from its back. The kerb-stones are graded in size and height, with the largest on the southern segment, and the bedrock is cut back to take them. Within the kerb the surface is levelled up with clay [21033, 21034, 21035]. A spread of stones [21032], particularly in the SW segment of the cairn, represents all that remains *in situ* of the cairn superstructure, now sealed by a layer of clayey silt with gravel [21023]. Within 21032, there is an alignment of boulders running E-W, perhaps the remains of a burial chamber. It is clear, however, that the cairn has been robbed. Small pieces of calcined bone and charcoal were recovered from the gravelly material [21023] and from the make-up deposits.



Illus 53 Standing stone at Finlaggan.

47. *STANDING STONES, PORTANEILEAN* (RCAHMS 1984, no 97)

(NR 392 685, NR 395 685)

The first stone, close to the Finlaggan farmstead, is still upright, 2m in height and 1.4m by 0.7m at the base, aligned with its long axis NW and SE. It has a plump outline and is of a rock type not found in the Finlaggan locality, best described as a metabasite. It exhibits signs of a planar fabric but still retains a massive almost knobby appearance. It is this fabric that has allowed the stone to exhibit two large faces and correspondingly two thinner edge faces. It is probably a glacial erratic. It is presumably one of the 'two stones set up at the east side of Loch-Finlagan ...six feet high' reported by Martin Martin in the late 17th century (Martin 1994, 275).

In 1994 Geophysical Surveys of Bradford undertook geophysical work around this stone. The survey area covered a rectangular area 40 by 60 sq m to the S and E of the stone. Magnetic susceptibility was measured revealing strong anomalies, tentatively identified as either archaeological or geological. It was thought possible that a prominent linear feature running NNW-SSE might be a palaeogene dyke. In order to throw more light on this a survey with an augur was undertaken across it, suggesting that this anomaly is in fact a ditch, presumably man made.

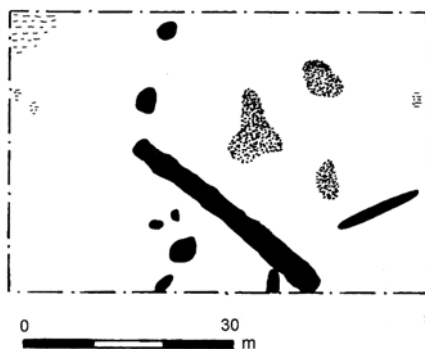
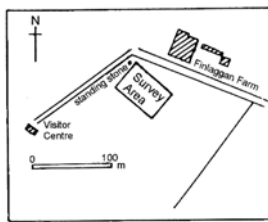

-  Archaeology?
-  Geology
-  Ferrous

Illus 54 Geophysical survey around Finlaggan standing stone.

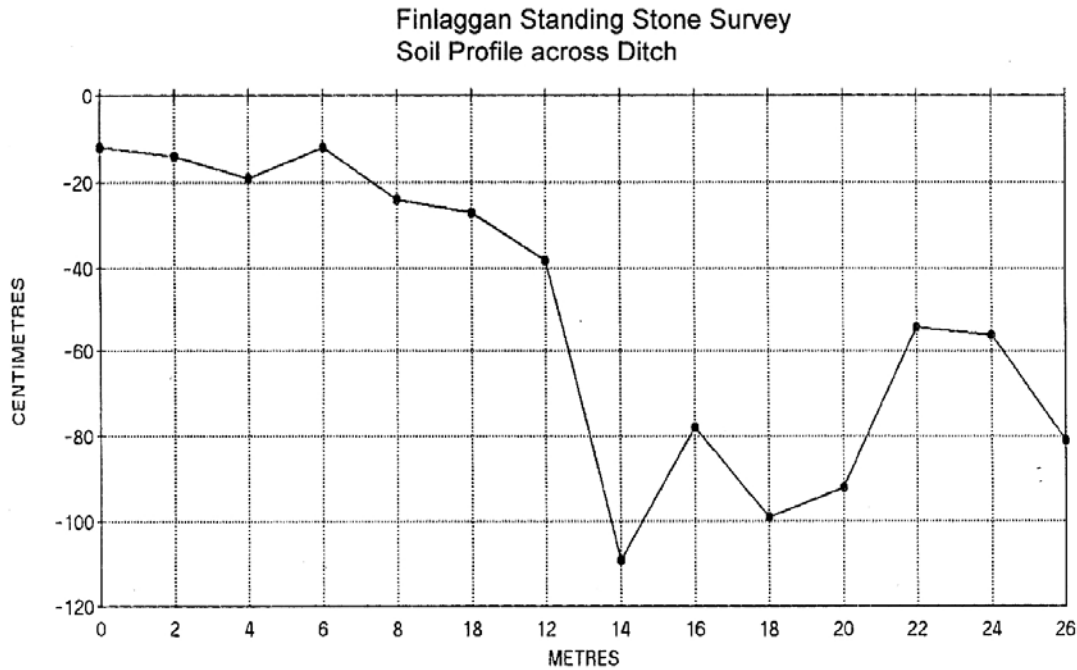

Illus 55.

The second standing stone reported by Martin Martin may have been one of the two large recumbent boulders, lying on a slope at the corner of a field a few metres to the E of the Finlaggan farmstead. These boulders have been scheduled as an ancient monument, apparently being considered to be a broken monolith. They are, however, of two different rock types, one metabasite, the other Port Askaig tillite. The former is 1.85m x 1.09m x 0.6m, the latter 2.0m x 1.0m x 0.6m.

48. *SETTLEMENT, PORTANEILEAN* (NR 395 683)

Adjacent to the Finlaggan Road and leat for the Mulreesh mill-pond are the vestigial traces of a settlement of two or more houses and a kiln. The houses are represented by grass covered foundations but there are several large blocks and boulders strewn about that presumably once formed their walls. One house of two chambers is 15.6m by 8.7. At right angles to it is a range, possibly all one house of four rooms, with an overall length of 23.3m and width of 6.4m. The kiln is several metres away, at NR 3967 6828, constructed in the side of a small hillock. There are traces of a flue running S. The kiln itself is totally denuded of stonework and the hole formed by its 2.2m diameter chamber has been back-filled with mine tailings. It was probably for corn-drying.

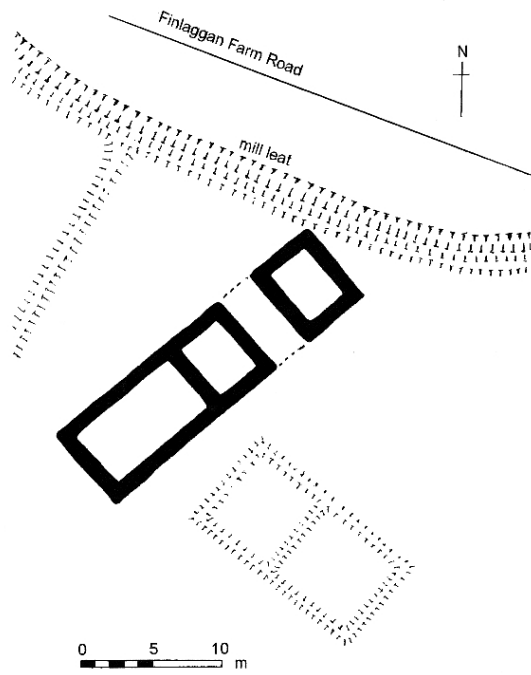

Illus 56 settlement no 48.

48a. *SETTLEMENT, PORTANEILEAN* (NR 400 681)

Two type C houses and a garden on the W side of the Mulreesh road just to the S of the turn-off for Finlaggan. The houses are reduced to grass covered foundations of turf and stone. One with three chambers, is 26.4m by 5.4m overall, the other about 7m by 5m with opposed entrances and the end wall of an earlier structure adjacent to one of its end walls. Between the two is a circular cut in the edge of a low bank, possibly the remains of a kiln.

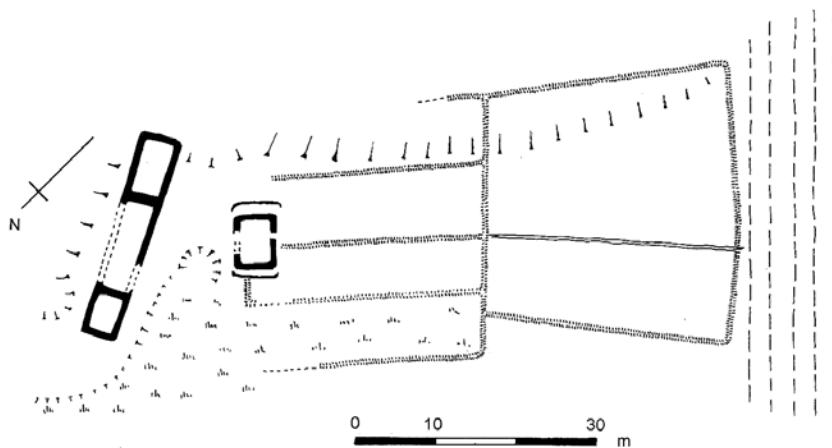

Illus 57 settlement no 48a.

49. *HUTS, CUING-SGEIR, PORTANEILEAN* (NR 391 680)

A low shieling mound, about 9.5m by 8.5m, by the loch's edge. At least two small oval huts, side by side, can be traced on its top.

50. *HUT, CUING-SGEIR, PORTANEILEAN* (NR 390 680)

The spreading grass covered remains of a circular structure, about 9m in diameter overall, situated on the edge of the loch; possibly a large hut with its entrance overlooking the water.

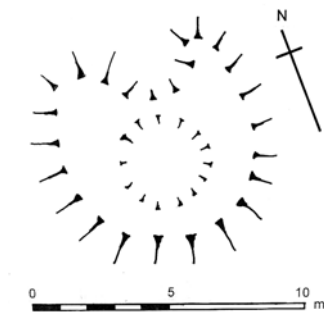

Illus 58 Hut no 50.

51. *HOUSE, CUING-SGEIR, PORTANEILEAN* (NR 392 680)

A low mound, about 10m in diameter within an area of rigs (see no 18), representing the collapsed remains of more than one superimposed houses. On top can be traced the outlines of a type A barrel-shaped house, about 8.5m by 3.5m. A curving stretch of turf bank on the E side of it probably represents the remains of an earlier house.

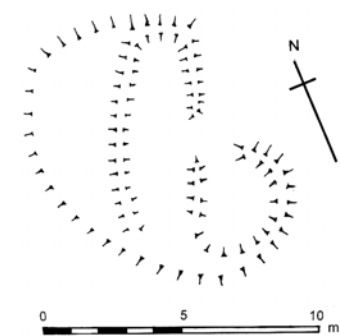

Illus 59 House no 51.

52. *HOUSE, CUING-SGEIR, PORTANEILEAN* (NR 390 679)

The turf covered boulder foundations of a rectangular type C house on a low headland, about 10m by 5.3m overall, end on to the loch.

53. *SETTLEMENT, (NORTH) MULREESH* (NR 402 688)

This group of houses is here described as N Mulreesh to distinguish it from another cluster further S. The adjectives north and south do not appear on maps or in documentary sources. For other houses at Mulreesh see the description of the Mulreesh Lead Mine (no 5).

There are the remains of seven houses at N Mulreesh, of which at least four are substantial type D houses, three with walls largely upstanding. The group is cut by the road to Balulive Farm, houses A and B to the W of it, and houses C-G to the E.

House A is of locally quarried stone set in lime mortar in rough courses, with limited use of bricks around the window openings. The walls of the main part of the house are largely upstanding. The core is a small rectangular unit about 9m by 6m overall with walls about 0.7m thick, with traces of external lime-based render. There are two windows, one on either side of the doorway positioned in the middle of the long S wall. There are the remains of a cast iron chimney-piece in the E gable. An animal house, divided into two stalls, has been added to the E. The use of cement-based mortar and render in it indicates relatively recent construction. It has an outshot against its N wall.

A second cottage, of similar size has been added to the W gable. It has a stone partition wall dividing the interior into two rooms, the larger one to the W with a fireplace in its gable wall. It also has an outshot at the back and another outhouse at its W end.

House B is a single cottage, 10m by 5.7m, and of similar construction to house A. No traces of windows survive, but there is a fireplace in the W gable and a scarcement in the wall above at ceiling height. An outhouse has been added to the W, and there is a small garden to the S, contained within a dry stone wall.

Across the road, house G is the only other substantial house with its walls partially upstanding. The RAF aerial photography survey of 1947 shows that this house was

still roofed at that time, with corrugated iron. Its walls are of quarried blocks of stone set in lime mortar. In overall size it is 8.9m by 5.4m with a fireplace in its W gable wall. The entrance is in the middle of the N wall and there are two windows to the S. An animal house, divided into two stalls, has been added to the E end.

House F is a small outhouse a few metres to the N with lime mortared walls of quarried material and field stones. It probably belongs with house G. To the NE of it stretch the grassed over foundations of an earlier house (E). House D is also reduced to grass covered foundations but can be distinguished as a long house, about 15.4m by 5.9m, divided into two chambers. Its walls were lime mortared. To the W of it are the foundations of house C, a small rectangular outhouse.

Houses A, B, D and G seem to be represented on the second edition Ordnance Survey Map of 1897. Houses D and G appear on the first edition map of 1878, but there, instead of house A, is a longer structure extending E to the edge of the road to Balulive. Tenuous traces of it may be detected to the E of house A. House B may also be represented on this map, or perhaps an earlier house on the same site, the W end of which can still be traced adjacent to the outhouse. The four houses on the first edition map can be matched by four on the early 19th-century plans by Gemmill which show N Mulreesh as a tightly grouped settlement of nine houses and outbuildings, with a road running through them and arable fields all around. One of the other houses represented by Gemmill may be house C. House E may already have been flattened by the early 19th century.

54. *SETTLEMENT*, (SOUTH) MULREESH (NR 402 685)

There are the grass covered foundations of five type C houses (H, I, J, K, L), all of which, apart from house K appear to be represented on Gemmill's plans of the early 19th century. Only part of house J was not abandoned by 1878. They are situated at the bottom of a steep slope. House I has all but been removed or buried by the banks of the ditch draining water from an adit further up the slope. The ditch has also removed the track that ascended the hill obliquely, running between houses H and J to join with the old main road from Portaneilean to Persabus.

The ruins of house H may represent two phases, a smaller rectangular house overlying an earlier longer house. On higher ground nearby to the E are the remains of a small circular kiln. House J is also multi-phase, sub-divided into four main rooms. The room second to the W, with a smaller sub-division in it, has walls of small quarried stones, and represents a rebuilding, or later house which superseded an earlier one with walls including large blocks and boulders. A large stone at the base of the E end of building J has within it a sectioned shot-hole (3

cm in diameter). House L is a simple rectangular ruin. House K may also have two phases, a smaller house perhaps replacing a longer one. There is now no trace of another ruined house shown on the 1st edition OS Map beside the old road to the S of house J. All trace of it may have been removed by the digging of a ditch draining from an adit of the lead mine.

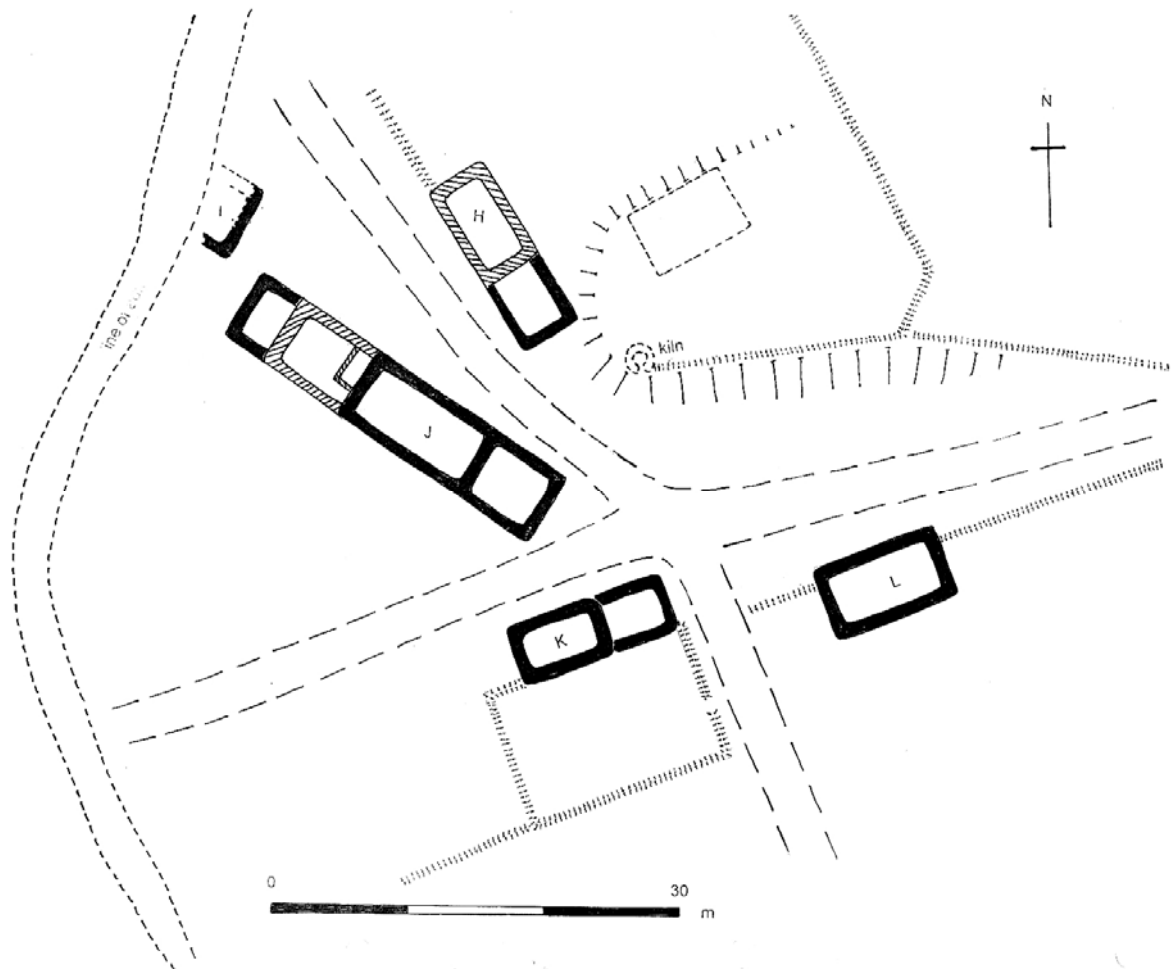

Illus 60 Mulreesh south.

55. *HOUSE, MULREESH* (NR 405 686)

The turf covered stone foundations of a type C rectangular house beside the old road from Mulreesh to Persabus, just to the W of the ford on the Allt an Tairbh and the settlement of Laoigan. The house is almost 15m by 7m with an entrance in the middle of one long side giving on to a small lobby in front of a mid-chamber. The house is not shown on the early 19th-century farm map or later OS maps.

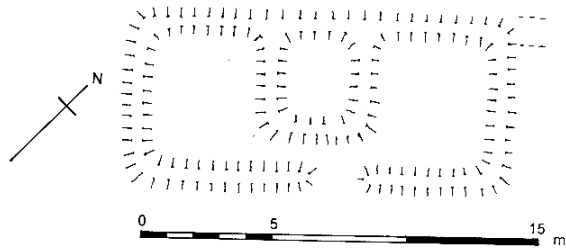

Illus 61 house no 55.

56. *SETTLEMENT, ROBOLLS (NR 396 668)*

The ruins of a settlement with evidence for as many as seven houses, adjacent to the grounds of the Ballygrant Inn, formerly known as Robolls House. The three (A, B, F) of which there are any significant remains are type D structures. The best preserved ruin, house A, is on low boggy ground beside a small stream and the old road which terraces Robolls Hill in the direction of Finlaggan. The other houses are on higher, rocky ground, mostly unsuitable for agriculture. House A is shown as complete on the 1878 OS Map. House B is depicted as a ruin and none of the other buildings are represented.

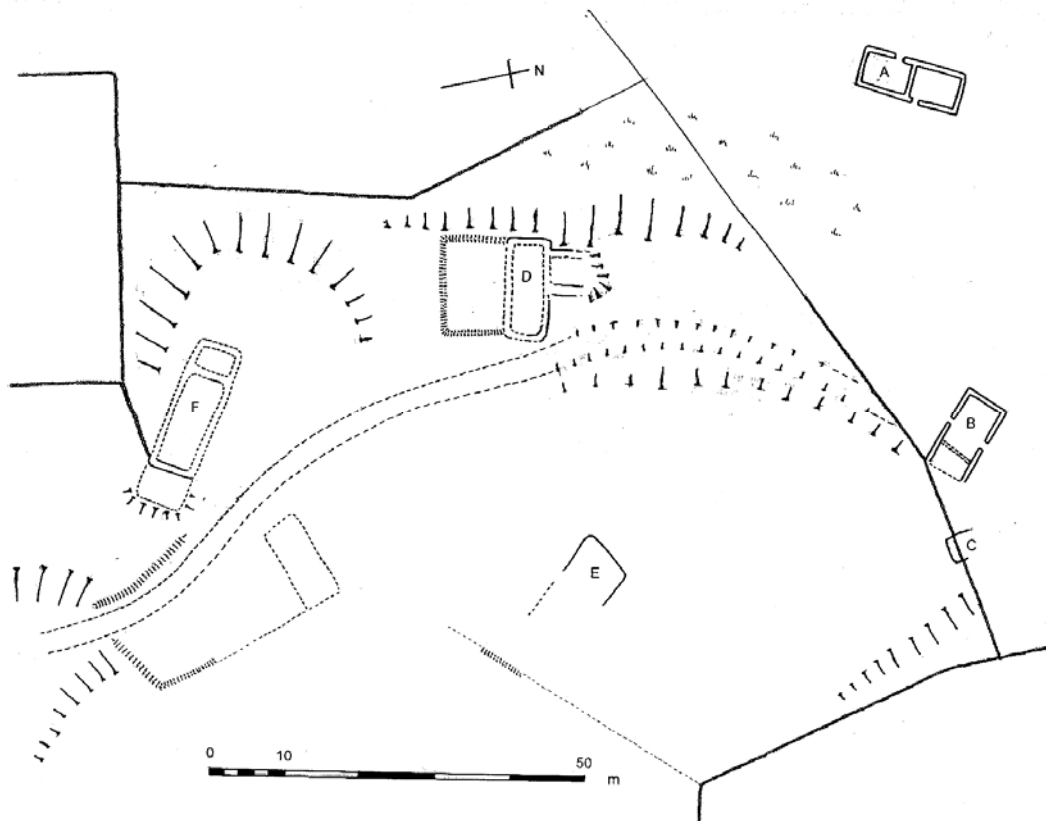

Illus 62 settlement at Robolls.

House A is reduced to one or two courses of stonework and heaps of rubble. It was constructed of quarried stone held in lime mortar and measures 14.25m by 5.5m overall. It was possibly a pair of semi-detached cottages. House B, of similar construction, and also reduced to its bottom courses, is built with one gable end cut into the adjacent higher ground. It has opposed entrances in its long sides, one blocked up. The adjacent house C is now only represented by a cut in the rock, as is house E on higher ground to the S. The remains of house D with its attached garden are vestigial. House F, a structure with at least two rooms, is partially represented by the trenches dug to rob out its foundations. It was constructed of quarried blocks of stone, mostly limestone, in a lime mortar. There are the tenuous traces of another house to the E, on the other side of a track running through the site.

Robolls House is an unpretentious mid 19th-century house of two stories. The main block is of three bays with an extension at the back forming a T-shape overall, much altered and extended through conversion to use as an inn. There is a separate stable, much altered, with space for horses and a carriage, and accommodation for a stable-boy.

57. *HOUSE, AN TÀMHANACHD, ROBOLLS (NR 390 678)*

The slumped turf remains of a type A oval house, about 11m by 8m overall, near the edge of the loch.

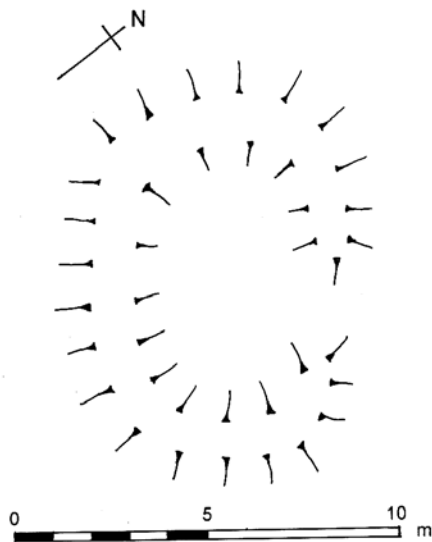

Illus 63 House no 57.

58. *HOUSE, AN TÀMHANACHD, ROBOLLS (NR 389 675)*

The slumped turf walls of a type A rectangular house, about 12m long, sited just below a bank beside a level area of rigs. Its width, at least 4.5m, is obscured by soil creep from the adjacent bank.

59. *KILN, AN TÀMHANACHD, ROBOLLS (NR 390 673)*

The ruins of a small circular kiln, cut in the side of a slope, with an overall diameter of about 4m and an internal diameter of about 2.2m. The lintel for its flue or rake-hole is still in place, facing WNW.

60. *HOUSE, AN TÀMHANACHD, ROBOLLS (NR 392 673)*

The turf covered stone foundations of a type C rectangular house, 9m by 9.25m overall. It is positioned on the head dyke.



61. *ISLAND DWELLING, EILEAN MHUIREILL, ROBOLLS (NR 386 673)*

This is a small, probably artificial, island near the SE shore of loch Finlagan, within site of Eilean Mor and Eilean na Comhairle. It measures about 23m by 19m. There are traces of a stone revetment around its edge, and at the NW a boat inlet, on the side away from the nearer loch-side. The water between the island and the shore is

too deep for a causeway. The foundations of two type A rectangular dry stone buildings with rounded corners, placed at right angles to each other, take up most of the summit area. Structure A is almost 10m by 5m overall, and probably had opposed entrances in its long sides. A supposed kerb running across its interior may be the remains of an earlier, underlying, structure. House B is about 10m by 6m overall (RCAHMS 1984, no 305; Holley 2000, 209-10).

62. ENCLOSURE, *AN TÀMHANACHD, ROBOLLS* (NR 388 672)

On a small grassy knoll a small sub-circular enclosure defined by a low grassy bank, 11.5m by 10m overall.

63. *HOUSE, ROBOLLS* (NR 389 663)

A 'hut circle' situated on a platform below the crest of a rise, with adjacent system of rigs, probably of much later date. They are about 4.5m wide and run from NE to SW. The hut circle is overall 12.9m by 11.9m with walls from 1.2m to 1.5m thick. These consist of a low bank in which are embedded orthostatic slabs and boulders forming an inner and an outer ring. They are mostly dolerite and limestone with a few phyllites and quartzites, and are typically about 0.5m in length. The entrance faces to the ESE.

64. *HUT, ROBOLLS* (NR 388 669)

The collapsed turf remains of an oval hut, about 6.25m by 5.4m. It is sited on a shoulder overlooking the loch.

65. *KILN, KEPOLLSMORE* (NR 387 667)

The turf covered ruins of a small circular kiln, probably for drying grain. It is set in the side of a bank, its flue facing W. Its walls are of quarried limestone blocks.

66. *HOUSE, KEPOLLSMORE* (NR 382 666)

A small square building about 3m across internally is built into the back of a small limestone knoll with its back wall formed by the rock face. Only its foundations survive. This perhaps represents, along with other nearby walls, one end of a long house about 18m long. The hillock is traversed by a mine rake tending N-S.

67. *KILN, KEPOLLSMORE* (NR 384 666)

The ruins of a small kiln, diameter 5.9m, set in the side of a bank, its opening facing NW.

68. *KILN, KEPOLLSMORE* (NR 381 662)

The well preserved remains of a small circular kiln, diameter 4.5m. Its walls are of quarried blocks of limestone and boulders, and there are traces of a flue extending southwards. It probably served for drying grain.

69. *FORT, DUN CHEAPAS Aidh MOR, KEPOLLSMORE* (NR 386 665)

The site is a flat topped, oval summit on the SW flank of Robolls Hill. The ground falls away steeply on all sides except the NE. There are tenuous remains of a stone rampart, with no sign of any facing blocks *in situ*, set back from the summit edge (RCAHMS 1984, no 146). The name is Gaelic for Kepollsmore Fort.

70. *STANDING STONE, KEPOLLSMORE* (NR 379 666)

The stone (RCAHMS 1984, no 105) apparently toppled sometime in the earlier part of the 20th century. When erect, it would have been in site of the standing stone by Finlaggan Farm at the other end of the loch. It is 2.4m in length, 1.5m in breadth and 0.5m in average thickness. It originally stood about 1.8m in height. The rock is a metabasite of similar type to the Finlaggan Farm stone.

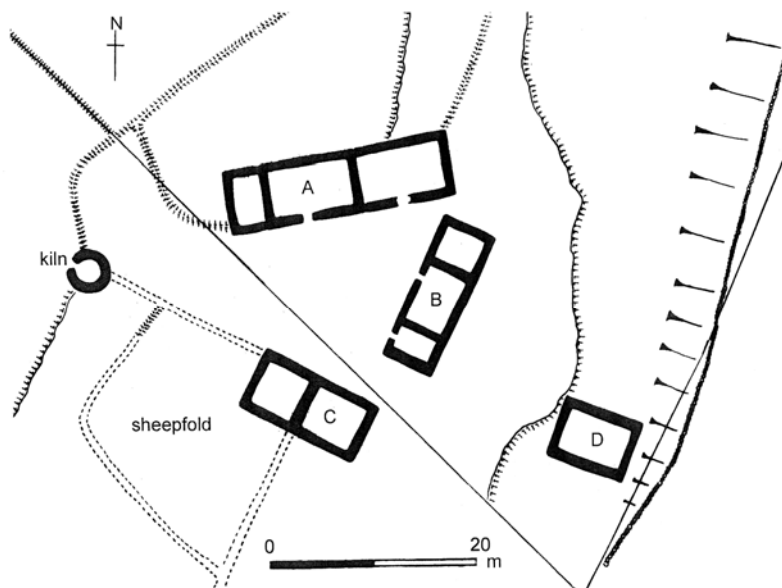

Illus 64 Kepollsmore west.

71. *SETTLEMENT, (WEST) KEPOLLSMORE (NR 381 661)*

The joint tenancy farm or township of Kepollsmore was typically divided into two clusters, labelled, by us, east and west. The W cluster is shown on the OS map of 1878 as totally abandoned. It consisted of four buildings, possibly all of type C, and yards on a rising piece of ground. The walls are now all grass covered with no traces of mortar, and may largely be of boulders. The largest house (A) is divided into three rooms, and has an overall size of 22m by 6.2m. House B with three rooms is 14.8m by 5.5m. House D is unicameral, 7.8m by 6m, and is tucked in between a rock face and the edge of the escarpment. House C has two rooms and an overall size of 12.3m by 5.9m. The enclosure beside it is identified as a sheepfold on the OS Map. The kiln lies a few metres to the W of house A, at the end of a rock face. It is small and circular, 4.1m in diameter overall, with its entrance facing NW. The stones forming the walls of the chamber are cracked and reddened by fire, suggesting it was used for burning lime.

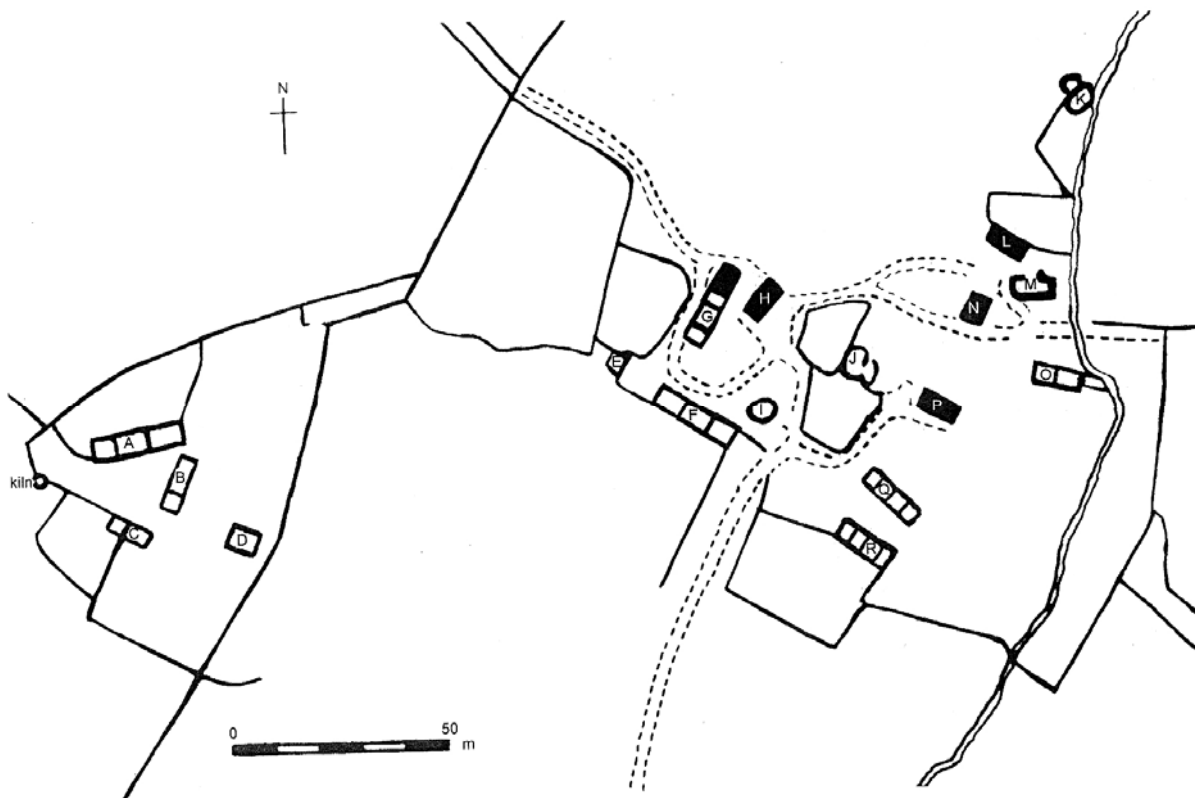

Illus 65 Kepollsmore.

72. *SETTLEMENT, (EAST) KEPOLLSMORE (NR 383 681)*

The E cluster is separated from W Kepollsmore by about 70m.

Most of the houses and yards of the larger E cluster, shown as partially occupied on the OS map of 1878, have now been swept away by the present day, working

farm of Kepollsmore (erroneously marked as Kepolls on the OS 1:25000 map). The Kepollsmore Farmhouse appears to be an improved and extended development from house P, and portions of other pre-1878 buildings, particularly G, H, N and O, may be incorporated in other structures still in use. The 1878 map indicates that four buildings, H, P, N and L were then roofed, and part of G. Contemporary rentals of Islay Estate in the Mitchell Library, Glasgow, list the number of tenants at Kepollsmore at this period dropping from five to four. These buildings can be identified as their houses.

Most of the E cluster is strung out to the W of a small burn that flows southwards to join the Ballygrant Burn. House P (the present farmhouse) and Q and R are on an oval flat-topped summit. Along with structures G, H, F, L, N and O, these appear to have been substantial houses. Building F may have been even bigger than indicated, extending to join up with E. It is possible that structure O, at a bend in the burn, could have contained a small mill. It is not clear whether all the structures labelled as I, J, K and M, were ruined houses or small enclosures.

73. *BURIAL GROUND, KEPOLLSMORE* (NR 381 658)

This alleged burial ground is marked on OS maps, but there is no trace of it on the ground.

74. *BURNT MOUND, KEPOLLSMORE* (NR 385 668)

It is situated beside a burn on a level piece of ground below the crest of a hill overlooking Loch Finlaggan. It appears as a low, circular mound with a diameter of about 9m. There is a hollow in the centre running down towards the burn. Where the turf surface has been trampled away by animals it can be seen to be composed of fragments of shattered, fire-reddened stones.

This is a good example of a type of monument that has only been widely recognised in Scotland in recent years. This one was discovered by the Royal Commission after the publication of the *Islay Inventory* which lists only four on Islay, all at Borraichill Mór, near Bridgend (RCAHMS 1984, no 246). Recent fieldwork by the author has led to the identification of another on a tributary of the Allt a' Chróth Earraich at NR 3897 7132, on the farm of Balulive, just to the N of Portaneilean/Finlaggan.

Burnt mounds consist of the debris from a type of cooking, often carried out in the open air, that involved the heating of the food – stew, soup or other food with a high liquid content – with stones (‘pot-boilers’) pre-heated on a fire. The cooking vessel

would often be a wooden trough set in the ground, and the heaps of cracked and broken pot-boilers accumulated round about. Many date to the Bronze Age, and one of the burnt mounds on Borraichill Mór has produced a radiocarbon determination of 1745 bc±60 (GU-1465) (Russell-White 1990, 82). This tradition of cooking, however, survived for a very long time in this part of the world. There is possible evidence of it in medieval times on Eilean Mor (see below, structures 19.7 and V.1), and it was reported as still being practised by the poorer elements in some of the Western Isles as late as the mid 18th century (Burt 1998, letter XXV, pp 271-2).

75. *SETTLEMENT, KEPOLLS, KEPOLLSMORE* (NR 373 653)

Remains of houses that might represent a settlement of Keppols(beg) of earlier date than the present Kepolls Farm-steading at NR 377 655, 300m to the E. About 100m behind a restored, occupied 19th-century cottage the grass-covered foundations of a small house are mostly obscured by dense gorse. The remains of another house and yard, just 50m to the NE of the occupied house, are presently lost to the gorse.