

RADIOCARBON DATING OF NEOLITHIC POTTERY

G Zaitseva¹ • V Skripkin² • N Kovaliukh² • G Possnert³ • P Dolukhanov⁴ • A Vybornov⁵

ABSTRACT. The direct measurement of organic matter included in archaeological pottery may yield a reliable assessment of age. The main problem consists in the identification of possible origins and assessment of distortion for the age of organic inclusions. Our experiments show that shells included in pottery fabrics are strongly influenced by the reservoir effect, which may reach 500 yr or more. Other organic inclusions, such as lake ooze, do not visibly distort the age. The obtained series of radiocarbon dates have been used for the assessing the age of the early stages of pottery manufacture in southern Russia.

INTRODUCTION

In principle, pottery is a promising material for dating because it is directly related to the archaeological context. The age of pottery assemblages until quite recently was usually estimated based on radiocarbon dates of samples of organic matter from the objects (hearths, seeds, wooden structures), which were deemed as synchronous with the pottery. However, this synchronicity can never be absolute. Hence, since the 1950s, attempts have been made to directly measure organic carbon derived from the pottery matrix. Kohl and Quitta (1964) were among the first who obtained dates for the early Neolithic LBK by direct dating of pottery carbon.

With the use of conventional ¹⁴C dating, the necessary amount of carbon (1 g of elementary carbon) was too large and necessitated the grinding of unacceptably large amounts of pottery. The situation has drastically changed with the advent of accelerator mass spectrometry (AMS) technology, which enabled the dating of much smaller samples. Yet many problems related to ¹⁴C dating of pottery remain unresolved.

There are sites where pottery constitutes the main material for dating in the absence of other datable organic materials, excluding animal bones. Sites of this type, indicative of early stages of pottery-making, were found in the southern regions of Russia, and the exact determination of their age is of paramount importance. The subject of this paper is the techniques used for direct dating of the organic matter included in the pottery fabrics, with a discussion of the obtained results.

The principle problem consists in the identification of the sources of organic matter embedded in the pottery fabrics. Several possible sources are acknowledged (Bonsall et al. 2002):

1. Carbon, penetrated jointly with the clay, and which had arisen in a distant geological past. Hence, its age may be much older than that of the pottery. In the clay usually used for pottery-making, this amount varies in the range of 0.05–0.2%, with limited deviations within a single outcrop;
2. Carbon derived from the temper (grass, straw, chaff, dung, and ground shells). The contemporaneity of these inclusions with the pottery-making and possible distortion of ¹⁴C age are discussed below;
3. Carbon absorbed from fuel while firing in the kiln;

¹Institute for History of Material Culture, St. Petersburg, Russia. Corresponding author. Email: ganna@mail.wplus.net.

²Institute of the Geochemistry of Environment, National Academy of Sciences of Ukraine, Kiev, Ukraine.

³University of Uppsala, Uppsala, Sweden.

⁴Newcastle University, Newcastle upon Tyne, United Kingdom.

⁵State Pedagogical University, Samara, Russia.

4. Carbon from food residues, the dates of which are usually deemed the most reliable. These residues are comparatively rare, however, and in some cases pose problems related to the reservoir effect;
5. Carbon resulting from contamination from the surrounding soil, mostly humic acids, may be easily removed by chemical treatment.

METHODS

Taking into account the above-mentioned limitations, the technology developed at the Kiev ^{14}C Laboratory, Institute of Environmental Geochemistry, enables one to obtain 95% benzene output with a near total absence of memory effect (Buzinny and Skripkin 1995). A Quantulus alpha-beta spectrometer was used, specially designed for low-background samples, using the vials to measure a small amount of the benzene.

Pottery samples of 200–400 g with a carbon content of 1–3% were taken from the vessel walls, and, rarely, from the bottom. The ground samples (10–22 mm in diameter) were treated with 0.5N hydrofluoric acid in a Teflon[®] container for 2–5 hr under indoor temperature. At the initial and final stages, the samples were subject to 10 min of ultrasonic exposure.

The samples were then finely ground, dried under 150–180 °C, and mixed with a calculated amount of manganese dioxide; the gaseous products were absorbed by lithium. The lithium carbide is synthesized with the use of “vacuum pyrolysis” (Skripkin and Kovalyukh 1998). The benzene was synthesized in a stainless steel reactor (Figure 1) under 0.1–2 atm of pressure. With the temperature rising above 550 °C, the manganese dioxide disintegrates with the uniform release of the active oxygen in a wide temperature range of 550–940 °C. The fine-dyspersated carbon was oxidized, forming carbon oxide and dioxide, which are absorbed by the melted metallic lithium. The lithium carbide is subjected to hydrolysis, and the released acetylene is turned into benzene with a vanadium catalyst.

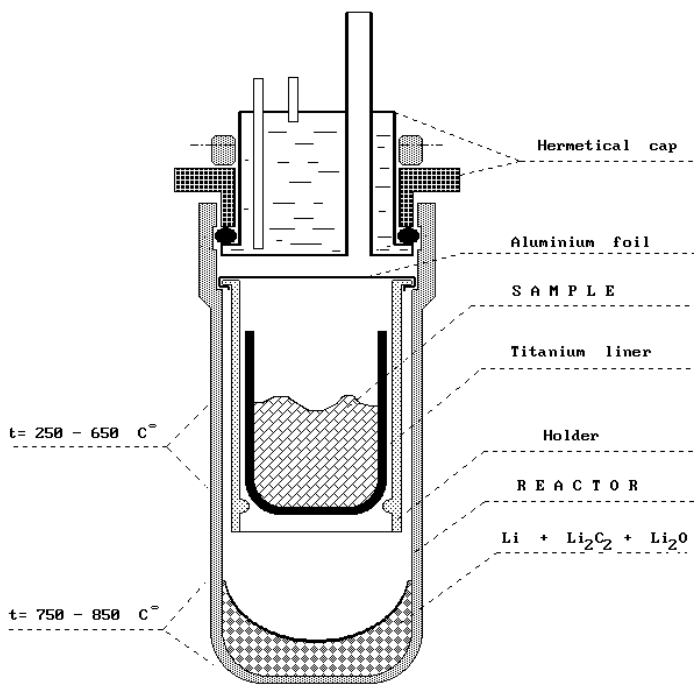

Figure 1 The principle scheme of the reactor to obtain benzene for the liquid scintillation technique.

YELSHANIAN CULTURE

The Yelshanian-type pottery as the earliest technology of this kind on East European Plain has been first recognized by I B Vasil'ev in the Samara-Volga area in the 1970s (Yudin 2005). By now, the typical "Yelshanian assemblage" has been identified at several sites: Staraya Yelshanka I, II, Maksimovo, Chekalino, Lower Orlyanka, Ivanovka, Lugovoye III, Lebyazh'ye I, Bol'she-Rakopvskaya, Il'yinskaya, Krasnyi Gorodok, Zakhar-Kolma, Vilovatovskaya, and a few more (Mamonov 1995). Amongst all these sites, the "pure Yelshanian element" has been recognized only in 2 cases, the lower strata of Chekalino IV and Lower Orlyanka II. (Figure 2, #9–14).



Figure 2 Map of the Neolithic sites in southern Russia and the Lower Volga River basin regions investigated: 1-Rakushechny Yar; 2-Matveyev kurgan; 3-Kairshak I-III; 4-Kugat IV; 5-Tektensor I, III; 6-Burovaya; 7-Varfolomeyevka; 8-Lebyazhinka; 9-Yelshanka; 10-Chekalino IV; 11-Maksimovka; 12-Ivanovskoe; 13-Dzangar; 14-Il'inka.

As the microscopic studies have shown, this pottery was manufactured from the local sandy clay, which included a natural admixture of organic matter and small fragments of mollusk shells. In rare cases, one notes the tempering by chamotte or old, crumbled pottery sherds. The vessels were fired in open hearths at temperatures not exceeding 450 °C. The majority of pottery vessels were not ornamented. Rarely, incised lines, pit impressions, or short notches, forming zigzag patterns, are seen. Several vessels were decorated by a belt beneath the rim consisting of pits and "pearl" impressions.

Presently, 25 ^{14}C dates are available for Yelshanian sites (Table 1). There are notable differences in the age obtained for the same site from different materials. Thus, the ^{14}C dates obtained for the freshwater shells from the cultural layers of Lebyazhinka IV and Chekalino-IV sites (about 8990–7940 BP) are older than those for the carbon in the pottery of the same sites (6100–5940 BP).

Table 1 ^{14}C dates of the Neolithic sites of the Volga River basin region.

Site	Index	Material	Age BP	Age, cal BC (2 σ)
Lebyazhinka IV	GIN-7088	Shells	8470 \pm 140	7950–7050
Lebyazhinka IV	Ki-14468	Pottery carbon	5970 \pm 80	5100–4600
Yelshanka	Ki-14569	Pottery carbon	6760 \pm 80	5800–5510
Yelshanka	Ki-14570	Pottery carbon	6480 \pm 80	5610–5300
Chekalino IV	Le-4782	Shells	8000 \pm 120	7350–6550
Chekalino IV	Le-4784	Shells	7940 \pm 140	7300–6450
Chekalino IV	GIN-7084	Shells	7950 \pm 130	7300–6450
Chekalino IV	Le-4781	Shells	8990 \pm 100	8450–7750
Chekalino IV	GIN-7085	Shells	8680 \pm 120	8250–7500
Chekalino IV	Ki-14686	Pottery carbon	5910 \pm 90	5000–4540
Chekalino IV	Ki-14687	Humic acids	6030 \pm 100	5300–4650
Chekalino IV	Ki-14688?	Pottery carbon	5870 \pm 80	4940–4530
Chekalino IV	Ki-14689	Shells	6100 \pm 140	5400–4650
Chekalino IV	Le-4783	Shells	7940 \pm 140	7300–6450
Maksimovka 2	Ki-14411	Pottery carbon	6430 \pm 80	5560–5250
Maksimovka 2	Ki-14412	Pottery carbon	6470 \pm 80	5640–5300
Ivanovka	Le-2343	Pottery carbon	8020 \pm 90	7300–6650
Ivanovka	Ki-14658	Pottery carbon	7930 \pm 80	7060–6630
Ivanovka	Ki-14567	Pottery carbon	7150 \pm 90	6220–5830
Ivanovka	Ki-14568	Pottery carbon	7680 \pm 90	6700–6260
Ivanovka	Ki-14568	Pottery carbon	7930 \pm 90	7100–6550
Ivanovka	Ki-14567	Pottery carbon	7680 \pm 90	6700–6260
Ivanovka	Ki-14631	Pottery carbon	7780 \pm 90	7050–6400
Staroyelshanka II	Ki-14413	Pottery carbon	6820 \pm 80	5880–5550
Il'inka	Le-5839	Shells	8510 \pm 60	7650–7370

NORTHERN CASPIAN AREA

The sites attributed to the Mesolithic and Neolithic sites in the Caspian Lowland and along the Lower Volga discovered since the 1980s, include Kairshak (Figure 2, #3), Tenkeskor (Figure 2, #5), Varfolomeyevka (Figure 2, #7), and many others. Based on typological grounds (Vasil'ev and Vybornov 1988; Vybornov 1990, 2008), 2 cultural groups were distinguished for the North Caspian early Neolithic: *Kairshak-Tenteksorian* and *Jangar-Varfolomeyevian*, which form together the Lower Volga cultural entity. The pottery consists of straight-walled vessels with round bases manufactured from clay with crushed shells and plant remains.

More than 50 ^{14}C dates for the 10 sites are available for the North Caspian area (Table 2). The majority of these dates has been obtained by direct dating of organic matter in pottery, using the methodology described above. In some cases, discrepancies between the measurements of various materials from the same sites are apparent. Thus, the dates obtained from the charcoal of the cultural layer of the Kairshak-III site are younger than those from the pottery carbon. This suggests that some of the dated materials were affected by the processes, which notably distorted their age. To test this hypothesis and to identify the possible sources of age distortions, we conducted multiple analyses of pot fragments from the site of the Tenteksor I.

Table 2 The ^{14}C dates of the Neolithic sites of the Caspian see region.

Site	Index	Material	Age (BP)	Age, cal BC (2σ)
Kairshak III	GIN-5905	Charcoal	6950 \pm 190	6250–5450
Kairshak III	GIN-5927	Charcoal	6720 \pm 80	5740–5480
Kairshak III	Ki-14133	Pottery carbon	7950 \pm 90	7080–6590
Kairshak III	Ki-14097	Pottery carbon	7890 \pm 90	7100–6500
Kairshak III	Ki-14471	Pottery carbon	7780 \pm 90	7050–6400
Kairshak III	Ki-14095	Pottery carbon	7740 \pm 70	6700–6430
Kairshak III	Ki-14096	Pottery carbon	7680 \pm 90	6700–6260
Kairshak III	Ki-14632	Pottery carbon	7530 \pm 90	6530–6210
Kugat IV	Ki-14501	Pottery carbon	7680 \pm 80	6690–6380
Kugat IV	Ki-14500	Pottery carbon	7560 \pm 90	6600–6220
Kairshak I	Ki-14094	Pottery carbon	7230 \pm 90	6390–6010
Kairshak I	Ki-14132	Pottery carbon	7180 \pm 90	6230–5840
Kairshak III, upper layer	Ki-14633	Animal bone	7190 \pm 80	6230–5890
Kairshak III, upper layer	Ki-14634	Animal bone	7010 \pm 80	6020–5720
Kairshak IV	Ki-14440a	Pottery carbon	7105 \pm 90	6170–5770
Kairshak IV	Ki-14440b	Pottery carbon	6960 \pm 80	6000–5710
Burovaya 42	Ki-14444	Pottery carbon	6920 \pm 90	5990–5630
Tenteksor III	Ki-14445	Pottery carbon	7005 \pm 90	6030–5710
Kachkarstau	Ki-14461	Pottery carbon	6730 \pm 80	5750–5480
Tenteksor I	GIN-6177	Humic acids	5500 \pm 150	4700–3950
Tenteksor I	Ki-14101	Pottery carbon	6640 \pm 80	5720–5470
Tenteksor I	Ki-14137	Pottery carbon	6630 \pm 80	5720–5460
Kyzylkhak	Ki-14443	Pottery carbon	6400 \pm 90	5600–5050
Kyzylkhak	Ki-1443	Pottery carbon	5905 \pm 100	5050–4500
Jangar, layer 1	Le-2901	Charcoal	5890 \pm 70	4940–4550
Jangar, layer 1	Ki-14643	Pottery carbon	5480 \pm 80	4490–4040
Jangar, layer 2	Le-2564	Charcoal	6100 \pm 70	5260–4800
Jangar, layer 2	Ki-14641	Pottery carbon	6780 \pm 90	5840–5510
Jangar, layer 2	Ki-14642	Pottery carbon	6680 \pm 90	5740–5470
Jangar, layer 3	Ki-14639	Pottery carbon	7080 \pm 90	6160–5740
Jangar, layer 3	Ki-14640	Pottery carbon	6990 \pm 90	6030–5710
Varfolomeyevka 2A	Ki-3589	Animal bone	5430 \pm 60	4350–4040
Varfolomeyevka 2A	Ki-3595	Animal bone	5390 \pm 60	4350–4040
Varfolomeyevka 2A	Ki-3590	Animal bone	5270 \pm 50	4230–3970
Varfolomeyevka 2A	Ki-3596	Animal bone	5220 \pm 50	4230–3940
Varfolomeyevka 2A	Ki-14372	Pottery carbon	7100 \pm 50	6070–5840
Varfolomeyevka 2A	Ki-14375	Pottery carbon	6970 \pm 80	6010–5710
Varfolomeyevka 2A	Ki-14371	Pottery carbon	6890 \pm 80	5980–5610
Varfolomeyevka 2A	Ki-14373	Pottery carbon	6860 \pm 90	5980–5630
Varfolomeyevka 2A	Ki-14613	Pottery carbon	6540 \pm 80	5622–5340
Varfolomeyevka 2A	Ki-14637	Pottery carbon	6040 \pm 80	5210–4720
Varfolomeyevka 2A	Ki-14614	Pottery carbon	5870 \pm 80	4940–4530
Varfolomeyevka 2A	Ki-14612	Pottery carbon	5810 \pm 80	4844–4461
Varfolomeyevka 2B	Lu-2642	Pottery carbon	6400 \pm 230	5750–4800
Varfolomeyevka 2B	Lu-2620	Pottery carbon	6040 \pm 160	5350–4550
Varfolomeyevka 2B	Ki-14374	Pottery carbon	7280 \pm 100	6390–5920
Varfolomeyevka 2B	Ki-14368	Pottery carbon	7230 \pm 90	6250–5890
Varfolomeyevka 2B	Ki-14370	Pottery carbon	7070 \pm 90	6160–5730
Varfolomeyevka 2B	Ki-14639	Pottery carbon	6980 \pm 90	6020–5710

Table 2 The ^{14}C dates of the Neolithic sites of the Caspian see region. (Continued)

Site	Index	Material	Age (BP)	Age, cal BC (2σ)
Varfolomeyevka, layer 3	GIN-6546	Pottery carbon	6980 ± 200	6250–5450
Varfolomeyevka, layer 3	Ki-14108	Pottery carbon	7760 ± 100	7050–6400
Varfolomeyevka, layer 3	Ki-14142	Pottery carbon	7620 ± 100	6650–6230
Varfolomeyevka, layer 3	Ki-14109	Pottery carbon	7250 ± 80	6250–5920
Varfolomeyevka, layer 3	Ki-14143	Pottery carbon	7170 ± 90	6230–5840
Varfolomeyevka, layer 3	Ki-14110	Pottery carbon	7080 ± 80	6160–5770
Varfolomeyevka, layer 3	Ki-14144	Pottery carbon	7120 ± 90	6207–5790

TENTEKSOR CASE STUDY

The TentekSOR I site occupies an area of about 300 m² and includes remains of a surface dwelling. The fragments of more than 170 vessels found at the site belonged to both profiled and straight-walled flat-based pots with either rounded or flat rims. They were made of clay tempered with crushed shells and vegetable matter. The ornament restricted to the upper portion of the vessels consisted of receding oval or square impressions, forming horizontal rows, rhombi, meanders, zigzags, triangles, and rectangles.

To test the reliability of direct pottery dating, microscopically visible plant remains and *Valvata* shell particles were extracted from the pottery mass and separately dated by AMS facilities at the Laboratory of Uppsala University (Sweden).

The measured age of the shells was 7235 ± 45 BP with $\delta^{13}\text{C} = -13.3\text{‰}$ (Ua-35226). That of the charcoal after the acid treatment was found to be 6695 ± 40 BP with $\delta^{13}\text{C} = -27.7\text{‰}$. The pottery fragments were consequently separated into inner ('the "terra-cotta" red-colored portion) and outer parts (the darker one). The shell particles were separated and treated by the HCl solution. After the treatment, the shells were dated by AMS. The remaining darker part was treated by hydrofluoric acid, to remove the contaminants. Following treatment, the darker part was also dated by AMS.

The ^{14}C age obtained for the darker part was 6695 ± 40 BP with $\delta^{13}\text{C} = -27.7\text{‰}$ (Ua-35227). This age is practically identical with that obtained at the Kiev Laboratory, 6630 ± 80 BP (Ki-14137), using liquid scintillation and the chemical pretreatment described above (Table 3).

Table 3 ^{14}C ages obtained for the pottery sample from TentekSOR I site at the Kiev Laboratory (liquid scintillation technique) and University of Uppsala (AMS).

Lab code	Material	^{14}C age (BP)	$\delta^{13}\text{C}$ (‰)	Calibrated age ($\pm 2\sigma$)
Ua-35226	Shells from pottery	7235 ± 45	-13.3	6220–6000
Ua-35227	Carbon from the pottery, darker part	6695 ± 40	-27.7	5720–5680 (78.9%); 5670–5520 (89.5%)
Ki-14137	Pottery carbon, entire sample	6630 ± 80	—	5730–5460

The differences in the ^{14}C dates obtained for the shells and the "darker" constituent of the pottery can be explained by the reservoir effect, which considerably distorted the age of the shells. The difference in the ^{14}C age of the shell and pottery carbon is about 550 yr. Significantly, the reservoir effect for lake fish is estimated in the range of 500–1500 yr, whereas this effect was not observed for animal bones (Van Strydonck et al. 2004).

Over the past few decades, new and impressive data sets of early pottery-bearing sites in the southern and southeastern areas of the East European Plain became available. They show an unexpectedly old age, often exceeding that of early farming sites in southeastern Europe. A large amount of these dates were obtained by means of direct dating of organic matter included in the pottery fabric.

The authenticity of these dates raises serious questions. The main problem consists in identifying the sources of origins of organic inclusions in the pottery and the possible distortion of their ^{14}C age. The current experiments show that pottery may be considered as a valid material for ^{14}C dating, provided several basic requirements are met.

As demonstrated above, the shells included in the pottery fabric are strongly influenced by the reservoir effect, which may exceed 500 yr. Therefore, first of all, pottery shells should be microscopically scanned in order to identify the temper and remove the shells. Secondly, the samples should be treated with diluted HCl and HF acids, destroying the shells as well as the silica aggregates. Other organic inclusions, such as lake ooze, do not visibly distort the age.

CONCLUSIONS

The obtained data prove the reliability of ^{14}C dating of pottery carbon, after the necessary chemical pretreatment and the removal the carbonates and shells in particular. The methodology developed at the Kiev Radiocarbon Laboratory makes feasible the dating of pottery carbon with the use of conventional dating. The newly obtained dates for pottery carbon lay a solid foundation for the chronology of early pottery culture in the southern East European Plain.

ACKNOWLEDGMENT

This research is supported by F6 European Project FEPRE. No. 028192.

REFERENCES

- Bonsall C, Cook G, Manson JL, Saderson D. 2002. Direct dating of Neolithic pottery: progress and prospects. *Documenta Praehistorica* XXIX:47–59.
- Buzinny M, Skripkin V. 1995. Newly designed 0.8-mL Teflon® vial for microvolume radiocarbon dating. *Radiocarbon* 37(2):743–7.
- Kohl G, Quitta H. 1964. Berlin radiocarbon measurements I. *Radiocarbon* 6:308–17.
- Mamonov AE. 1995. Yelshanskii kompleks stojanki Chekalino IV. In: Vasil'ev IB, editor. *Drevnie kul'tury lesostepnogo Povolzh'ya*. Samara: Samara State Pedagogical University. p 3–25.
- Skripkin VV, Kovalyukh NN. 1998. Recent developments in the procedures used at the SSCER laboratory for the routine preparation of lithium carbide. *Radiocarbon* 40(1):211–4.
- Van Strydonck M, Boudin M, Eryvnc A. 2004. Possibilities and limitations of the use of stable isotopes ($\delta^{13}\text{C}$ and $\delta^{15}\text{N}$) from human bone collagen and carbonate as an aid in migration studies. In: Scott EM, Alekseev AY, Zaitseva G, editors. *Impact of the Environment of Human Migration in Eurasia*. NATO Science Series, Volume 42. Dordrecht: Kluwer Academic. p 125–35.
- Vasil'ev IB, Vybornov AA. 1988. *Neolit Povolzh'ya*. Kuibyshev: State Pedagogical Institute.
- Vybornov AA. 1990. Neolit Severnogo Prikaspiya I ego sootnoshenie s kul'turami sopedelk'nyh territorii. In: Vasil'ev IB, editor. *Problemy drevnei istorii Severnogo Prikaspiya*. Kuibyshev: State Pedagogical Institute.
- Vybornov AA. 2008. *The Neolithic of the Volga-Kama Rivers Basin*. Samara: Samara State Pedagogical University Monograph. In Russian.
- Yudin AI. 2005. Low Volga cultural community of the Neolithic: the problems of formation, contacts and evolution. In: *Proceedings of the Scientific Conference Devoted to the 100th Anniversary of V.A. Gorodtsov in the State Historical Museum*. April 2003. Moscow. p 7–17. In Russian.