

B5254T, 850

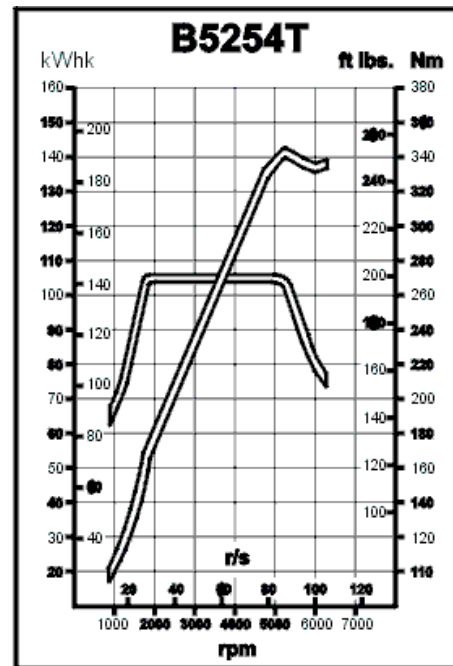
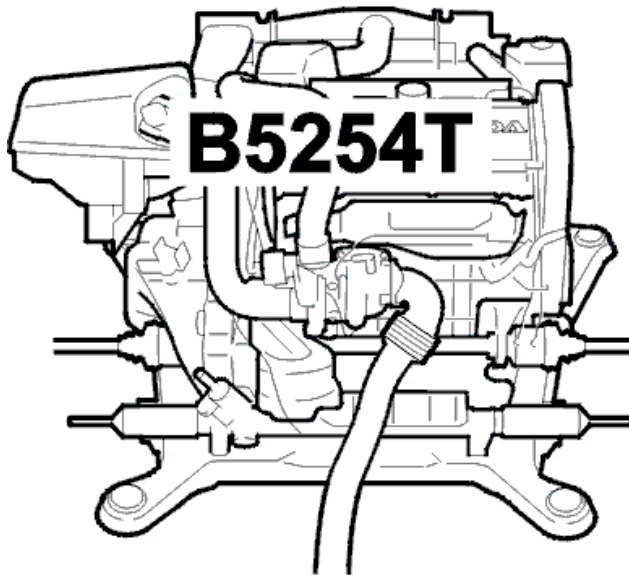

20001388 © VOLVO

New engine

The Volvo 850 engine range has been extended with another engine variant B5254T. This is an engine which has been optimized for the best possible comfort. The B5254T has extremely good characteristics at low engine speeds.

Because of the engine's excellent pulling power at low speed it is also used in the Volvo 850 AWD. The B5254T is also used in other 850 models and is then available with a manual transmission (M56H) or automatic transmission (AW50-42).

Gear ratios and final drive ratios are the same as for the B5234T.

On cars with the B5254T comfort has been prioritized ahead of performance and therefore the boost pressure gauge in the combined instrument panel is not required.

Performance

Maximum torque is 270 Nm (199 lb.ft.) and is reached between 1800-5000 rpm.

Maximum output is 142kW (193 bhp) obtained at 5100 rpm.

Differences to the B5234T

Compared to the B5234T the following differences can be seen:

- Cylinder diameter is 83 mm (3.27 inch) (as in the B5254S).
- Another piston with new piston ring assembly.
- Modified turbocharger (TC) with slightly smaller compressor wheel to be able to increase boost pressure at low engine speeds more quickly.

The diameter of the port for the boost pressure control (BPC) valve is larger (\varnothing 28 (1.10 inch) instead of 26 mm (1.02 inch)).

The boost pressure control (BPC) valve is larger (\varnothing 35 (1.38 inch) instead of 33 mm (1.29 inch)).

The pressure regulator has a slightly weaker spring.

- Maximum boost pressure is reduced from 0.6 kPa (0.09 psi) to approximately 0.4 kPa (0.06 psi).
- Air cleaner (ACL) cover without the text "TURBO".
- New three-way catalytic converter (TWC) (but downstream the system = B5234T AWD however has a completely new exhaust system).
- Motronic 4.4 Engine management system.

Summary of general data B5254T	
Power	142 kW (193 bhp) obtained at 5100 rpm
Torque	270 Nm (199 lb.ft.) and is reached between 1800 -5000 rpm
Maximum boost pressure	approximately 0.4 kPa (0.06 psi)
Cylinder diameter	83 mm (3.27 inch)
Compression	9.0:1
Cylinder stroke	90 mm (3.54 inch)
Cylinder capacity	2.435 dm ³
Engine management system	Motronic 4.4