

RF/Microwave Semiconductors Product Guide

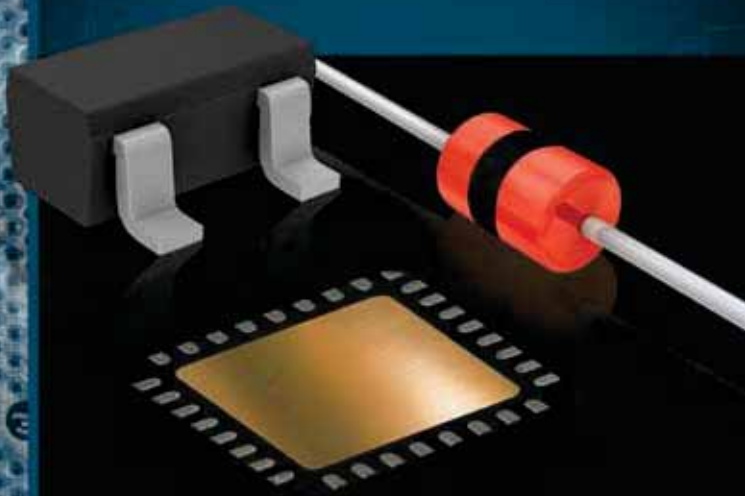

**Massachusetts Bay
Technologies**

Motivated by Performance, Focused on Reliability.®

INTRODUCTION

Founded in March 1999, Massachusetts Bay Technologies, Inc. (MBT) is a company specializing in the design, manufacture, and distribution of discrete Silicon RF/Microwave semiconductor devices.

MBT designs and produces all of its semiconductor products in its 16,000 square foot facility located in Stoughton, MA.

MBT is committed to the continuance of innovations in service to its customers, improvement of design, product performance, and quality control. MBT'S product frequencies range from 100Hz up to and including millimeter wave; our quality devices are used in various industry applications such as university and laboratory research, consumer products, telecommunications, aerospace and military.

This catalog represents our complete line of semiconductors which includes PIN limiter diodes, tuning and multiplier varactors, schottky mixer and detector diodes, point contact mixers and detectors, chip capacitors, spiral inductor coils, tantalum nitride resistors chips and fixed value attenuator pads.

MBT's consistent objective is to provide a superior product with unsurpassed customer service to our clients. Our engineers and sales representatives are available to discuss your specific design and application need in a professional manner that is both cost and time effective. We look forward to providing you component expertise and quality products.

TABLE OF CONTENTS

Tuning Varactors

30 Volt Abrupt.....	1-2
45 Volt Abrupt.....	3-4
60 Volt Abrupt	5-6
90 Volt Abrupt.....	7-8
HF Hyperabrupt.....	9
VHF Hyperabrupt.....	10
UHF Hyperabrupt	11
Microwave Hyperabrupt.....	12
Low Cost Hyperabrupt.....	13

Multiplier Devices

Multiplier Diodes.....	14
Super And Standard Multiplier Diodes	15
Step Recovery Diodes	16-17

Control Devices

Low-High Power PIN Diodes.....	18-21
Limiter Diodes	22
Beam Lead PIN Diodes.....	23

Schottky Diodes

Low Barrier Mixer Diodes	24
Medium Barrier Mixer Diodes	25
High Barrier Mixer Diodes.....	26
Zero Bias Detector Diodes	27
General Purpose Schottky Mixer Diodes.....	28
Low Barrier Ring Quads.....	29
Medium Barrier Ring Quads.....	30
High Barrier Ring Quads	31
Phase Detector Hybrids.....	32

Point Contact Diodes

Ka Band Mixer Diodes	33
S-X Band Mixer Diodes.....	34
X Band Mixer Diodes	35
Ka Band Detector Diodes	36

Passive Components

MIS Chip Capacitors	37-38
MIC Mounting Capacitors.....	39
Binary Chip Capacitors	40
Spiral Inductors	41
Thin Film Resistor Chips	43
Thin Film Attenuator Pads	44

Package Styles..... 45-52

Application Notes

Tuning Varactors	53-55
PIN Diodes	56-57
Step Recovery Diodes	58-60
Chip and Beam Lead Handling.....	61

Quality and Reliability..... 62-64

Warranty/Ordering Information..... 65

Part Number Index..... 66-68

30-VOLT ABRUPT TUNING VARACTORS

Tuning Varactors: MBT 3000 Series

Description

The Massachusetts Bay Technologies MBT3000's series Tuning Varactors are silicon abrupt junction devices. Each device has been designed to obtain the highest Q and lowest resistance possible in 30 volt tuning diodes. Each device in this series has a high density silicon dioxide passivation which results in exceptionally low leakage currents at higher temperatures.

Applications

The MBT3000 series of silicon tuning diodes are used for both narrow and wideband tuning. They are suited for frequency tuning applications through KU band. The MBT3000 series are used in phase shifters, voltage controlled oscillators and frequency synthesizers.

Standard capacitance tolerance is $\pm 10\%$. Diodes can be optimized for custom electrical or mechanical specification upon request.

Features

- Low Series Resistance - High Q
- Extensive Selection of Capacitance Values

Packaging

- Available in a wide Range of Case Styles as well as Chip Form

Typical Performance

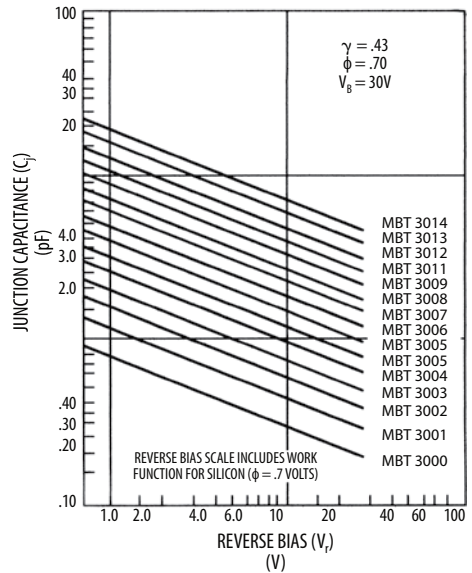

30-VOLT SILICON TUNING VARACTORS

Electrical Specifications

$T_A = 25^\circ\text{C}$

MODEL NUMBER	TOTAL CAPACITANCE ¹ (AT -4V MHz) C_{t-4} (pF)	QUALITY FACTOR ² (AT -4V, 50 MHz) Q_{-4} (MIN)	CAPACITANCE RATIO ¹ (C_{t0}/C_{t30}) (MIN)
MBT3000	0.4	5000	5.0
MBT3001	0.8	3900	5.0
MBT3002	1.0	3800	5.0
MBT3003	1.2	3800	5.0
MBT3004	1.5	3600	5.0
MBT3005	1.8	3500	5.0
MBT3006	2.2	3500	5.0
MBT3007	2.7	3300	5.0
MBT3008	3.3	3100	5.0
MBT3009	3.9	2700	5.0
MBT3010	4.7	2600	5.0
MBT3011	5.6	2600	5.0
MBT3012	6.8	2400	5.0
MBT3013	8.2	2200	5.0
MBT3014	10.0	2200	5.0
MBT3015	12.0	2100	5.0
MBT3016	15.0	2000	5.0
MBT3017	18.0	1800	5.0
MBT3018	22.0	1600	5.0
MBT3019	27.0	1400	5.0
MBT3020	33.0	1400	5.0
MBT3021	39.0	1200	5.0
MBT3022	47.0	1000	5.0

NOTES:

1. These values include a package capacitance of .18 pF (PS-47).
2. Q is calculated from: $Q = \frac{1}{2\pi f R_s C_j}$ where $f = 50$ MHz and $R_s =$ Series resistance measured at 1 GHz using transmission loss techniques. Capacitance is measured at 1 MHz.
3. When ordering, specify the desired case style by adding its number as a suffix to the basic part number. Other case styles are available on request.

RATINGS

Minimum Voltage Breakdown:

30 volts at 10 μA max

Maximum Leakage Current:

0.02 μA at 25 volts and 25 $^\circ\text{C}$
2.0 μA at 25 volts and 125 $^\circ\text{C}$

Capacitance-Temperature Coefficient:

300 ppm/ $^\circ\text{C}$ at $V_R = -4\text{V}$

Operating Temperature:

-55 $^\circ\text{C}$ to +150 $^\circ\text{C}$

45-VOLT ABRUPT TUNING VARACTORS

Tuning Varactors: MBT 4500 Series

Description

The Massachusetts Bay Technologies MBT4500's series Tuning Varactors are silicon abrupt junction devices. Each device has been designed to obtain the highest Q and lowest resistance possible in 45 volt tuning diodes. Each device in this series has a high density silicon dioxide passivation which results in exceptionally low leakage currents at higher temperatures.

Applications

The MBT4500 series of silicon tuning diodes are used for both narrow and wideband tuning. They are suited for frequency tuning applications through KU band. The MBT4500 series are used in phase shifters, voltage controlled oscillators and frequency synthesizers.

Standard capacitance tolerance is $\pm 10\%$. Diodes can be optimized for custom electrical or mechanical specifications upon request.

Features

- Low Series Resistance - High Q
- Extensive Selection of Capacitance Values

Packaging

- Available in a wide Range of Case Styles as well as Chip Form

Typical Performance

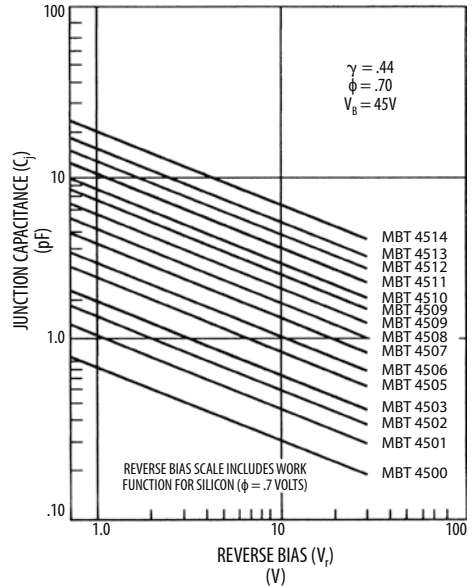

45-VOLT SILICON TUNING VARACTORS

Electrical Specifications

$T_A = 25^\circ\text{C}$

MODEL NUMBER	TOTAL CAPACITANCE ¹ (AT -4V MHz) C_{t-4} (pF)	QUALITY FACTOR ² (AT -4V, 50 MHz) Q_{-4} (MIN)	CAPACITANCE RATIO ¹ (C_{t0}/C_{t45}) (MIN)
MBT4500	0.4	3000	7.0
MBT4501	0.8	2900	7.0
MBT4502	1.0	2800	7.0
MBT4503	1.2	2800	7.0
MBT4504	1.5	2300	7.0
MBT4505	1.8	2300	7.0
MBT4506	2.2	2200	7.0
MBT4507	2.7	2000	7.0
MBT4508	3.3	2000	7.0
MBT4509	3.9	1900	7.0
MBT4510	4.7	1900	7.0
MBT4511	5.6	1700	7.0
MBT4512	6.8	1700	7.0
MBT4513	8.2	1500	7.0
MBT4514	10.0	1500	7.0
MBT4515	12.0	1500	7.0
MBT4516	15.0	1400	7.0
MBT4517	18.0	1300	7.0
MBT4518	22.0	1200	7.0
MBT4519	27.0	1200	7.0
MBT4520	33.0	1100	7.0
MBT4521	39.0	1000	7.0
MBT4522	47.0	800	7.0

NOTES:

1. These values include a package capacitance of .18 pF (PS-47).
2. Q is calculated from: $Q = \frac{1}{2\pi f R_s C_j}$ where $f = 50$ MHz and $R_s =$ Series resistance measured at 1 GHz using transmission loss techniques. Capacitance is measured at 1 MHz.
3. When ordering, specify the desired case style by adding its number as a suffix to the basic part number. Other case styles are available on request.

RATINGS

Minimum Voltage Breakdown:

45 volts at 10 μA max

Maximum Leakage Current:

0.02 μA at 35 volts and 25°C
2.0 μA at 35 volts and 125°C

Capacitance-Temperature Coefficient:

300 ppm/°C at $V_R = -4\text{V}$

Operating Temperature:

-55°C to +150°C

Storage Temperature:

-65°C to +200°C

60-VOLT ABRUPT TUNING VARACTORS

Tuning Varactors: MBT 6000 Series

Description

The Massachusetts Bay Technologies MBT6000's series Tuning Varactors are silicon abrupt junction devices. Each device has been designed to obtain the highest Q and lowest resistance possible in 60 volt tuning diodes. Each device in this series has a high density silicon dioxide passivation which results in exceptionally low leakage currents at higher temperatures.

Applications

The MBT6000 series of silicon tuning diodes are used for both narrow and wideband tuning. They are suited for frequency tuning applications through KU band. The MBT6000 series are used in phase shifters, voltage controlled oscillators and frequency synthesizers.

Standard capacitance tolerance is $\pm 10\%$. Diodes can be optimized for custom electrical or mechanical specification upon request.

Features

- Low Series Resistance - High Q
- Extensive Selection of Capacitance Values

Packaging

- Available in a wide Range of Case Styles as well as Chip Form

Typical Performance

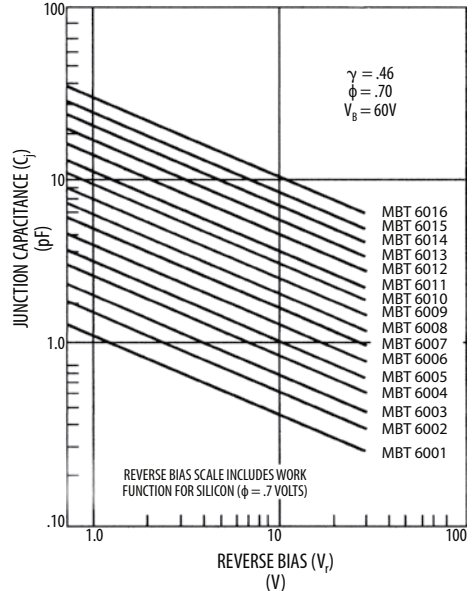

60-VOLT SILICON TUNING VARACTORS

Electrical Specifications

$T_A = 25^\circ\text{C}$

MODEL NUMBER	TOTAL CAPACITANCE ¹ (AT -4V, 50 MHz) C_{t-4} (pF)	QUALITY FACTOR ² (AT -4V, 50 MHz) Q_{-4} (MIN)	CAPACITANCE RATIO ¹ (C_{t0}/C_{t60}) (MIN)
MBT6000	0.4	2200	8.0
MBT6001	0.8	2100	8.0
MBT6002	1.0	2000	8.0
MBT6003	1.2	1800	8.0
MBT6004	1.5	1800	8.0
MBT6005	1.8	1700	8.0
MBT6006	2.2	1700	8.0
MBT6007	2.7	1600	8.0
MBT6008	3.3	1600	8.0
MBT6009	3.9	1400	8.0
MBT6010	4.7	1400	8.0
MBT6011	5.6	1400	8.0
MBT6012	6.8	1300	8.0
MBT6013	8.2	1300	8.0
MBT6014	10.0	1200	8.0
MBT6015	12.0	1200	8.0
MBT6016	15.0	1100	8.0
MBT6017	18.0	1000	8.0
MBT6018	22.0	1000	8.0
MBT6019	27.0	900	8.0
MBT6020	33.0	800	8.0
MBT6021	39.0	800	8.0
MBT6022	47.0	700	8.0

NOTES:

1. These values include a package capacitance of .18 pF (PS-47).
2. Q is calculated from: $Q = \frac{1}{2\pi f R_s C_j}$ where $f = 50$ MHz and $R_s =$ Series resistance measured at 1 GHz using transmission loss techniques. Capacitance is measured at 1 MHz.
3. When ordering, specify the desired case style by adding its number as a suffix to the basic part number. Some other case styles are available on request.

RATINGS

Minimum Voltage Breakdown:	60 volts at 10 μA max
Maximum Leakage Current:	0.02 μA at 55 volts and 25°C 2.0 μA at 25 volts and 125°C
Capacitance-Temperature Coefficient:	300 ppm/ $^\circ\text{C}$ at $V_R = -4\text{V}$
Operating Temperature:	-55°C to $+150^\circ\text{C}$
Storage Temperature:	-65°C to $+200^\circ\text{C}$

90-VOLT ABRUPT TUNING VARACTORS

Tuning Varactors: MBT 9000 Series

Description

The Massachusetts Bay Technologies MBT9000's series Tuning Varactors are silicon abrupt junction devices. Each device has been designed to obtain the highest Q and lowest resistance possible in 90 volt tuning diodes. Each device in this series has a high density silicon dioxide passivation which results in exceptionally low leakage currents at higher temperatures.

Applications

The MBT9000 series of silicon tuning diodes are used for both narrow and wideband tuning. They are suited for frequency tuning applications through KU band. The MBT9000 series are used in phase shifters, voltage controlled oscillators and frequency synthesizers.

Standard capacitance tolerance is $\pm 10\%$. Diodes can be optimized for custom electrical or mechanical specification upon request.

Features

- Low Series Resistance - High Q
- Extensive Selection of Capacitance Values

Packaging

- Available in a wide Range of Case Styles as well as Chip Form

Typical Performance

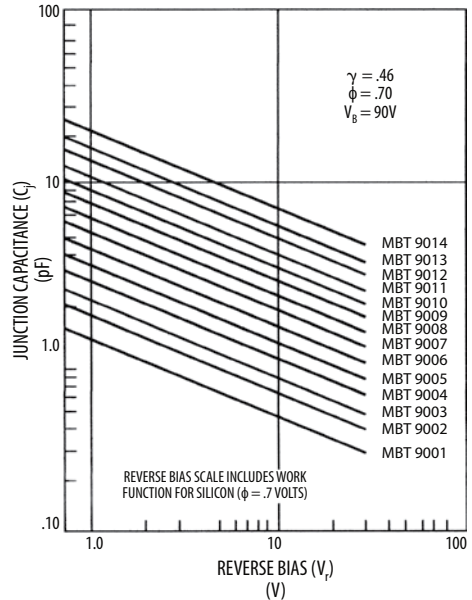

90-VOLT SILICON TUNING VARACTORS

Electrical Specifications

$T_A = 25^\circ\text{C}$

MODEL NUMBER	TOTAL CAPACITANCE ¹ (AT -4V MHz) C_{t-4} (pF)	QUALITY FACTOR ² (AT -4V, 50 MHz) Q_{-4} (MIN)	CAPACITANCE RATIO ¹ (C_{t0}/C_{t90}) (MIN)
MBT9000	0.4	1100	8.0
MBT9001	0.8	1000	8.0
MBT9002	1.0	1000	8.0
MBT9003	1.2	900	8.0
MBT9004	1.5	900	8.0
MBT9005	1.8	850	8.0
MBT9006	2.2	850	8.0
MBT9007	2.7	800	8.0
MBT9008	3.3	800	8.0
MBT9009	3.9	700	8.0
MBT9010	4.7	700	8.0
MBT9011	5.6	650	8.0
MBT9012	6.8	650	8.0
MBT9013	8.2	600	8.0
MBT9014	10.0	600	8.0
MBT9015	12.0	550	8.0
MBT9016	15.0	550	8.0
MBT9017	18.0	550	8.0
MBT9018	22.0	550	8.0
MBT9019	27.0	500	8.0
MBT9020	33.0	500	8.0
MBT9021	39.0	500	8.0
MBT9022	47.0	450	8.0

NOTES:

1. These values include a package capacitance of .18 pF (PS-47).
2. Q is calculated from: $Q = \frac{1}{2\pi f R_s C_j}$ where $f = 50$ MHz and R_s = Series resistance measured at 1 GHz using transmission loss techniques. Capacitance is measured at 1 MHz.
3. When ordering, specify the desired case style by adding its number as a suffix to the basic part number. Some other case styles are available on request.

RATINGS

Minimum Voltage Breakdown:

90 volts at 10 μA max

Maximum Leakage Current:

0.02 μA at 80 volts and 25°C

2.0 μA at 80 volts and 125°C

Capacitance-Temperature Coefficient:

300 ppm/°C at $V_R = -4\text{V}$

Operating Temperature:

-55°C to +150°C

Storage Temperature:

-65°C to +200°C

HF HYPERABRUPT TUNING VARACTORS

Tuning Varactors: MBV 7400-7800

Description

The Massachusetts Bay Technologies high frequency Hyperabrupt diodes feature ion implanted epi construction. They are ideal for tuning LC resonant circuits up to 100 MHz and wide deviation voltage tuned crystal oscillators.

Packaging

Available in a wide range of package styles as well as chip form.

Electrical Specifications

$T_A = 25^\circ\text{C}$

Features: Medium to HF operation • Ultra high Q • 10:1 tuning ratio from 2 to 10 volts • Linear frequency performance versus voltage

TYPE	C_T Diode Capacitance (pF) f=1 MHz				TR Tuning Ratio f=1 MHz		Q FIGURE OF MERIT				V_{BR} (Vdc)	I_R (nA dc)
	$V_R = 1.25 \text{ Vdc}$				$V_R = 2 \text{ Vdc}$		$V_R = 7 \text{ Vdc}$		$V_R = 10 \text{ Vdc}$		$I_R = 10 \mu\text{A dc}$	$V_R = 10 \text{ Vdc}$
	MIN/TYP/MAX	MIN/TYP/MAX	MIN/TYP/MAX	MIN/TYP/MAX	C(1.25V)/C(7V) MIN/TYP/MAX	C(2V)/C(10V) MIN/TYP/MAX	f=1 MHz MIN	f=10 MHz MIN	f=1 MHz MIN	f=10 MHz MIN		
MBV7401	-81.5/-	46/47/68	-/6.1/-	4.2/4.7/5.2	-/13/-	10/12/17	-	-	-	140	12/20	50
MBV7402	-81.5/-	46/57/68	-/6.1/-	4.2/4.7/5.2	-/13/-	10/12/17	-	-	700	-	12/20	100
MBV7403	-81.5/-	46/57/-	-/6.1/-	-4.7/5.2	-/13/-	10/12/-	-	-	700	-	12/20	1000
MBV7501	-/180/-	100/125/150	-/13/-	8.6/9.6/10.6	-/14/-	10/13/17.5	-	-	-	130	12/20	50
MBV7502	-/180/-	100/125/150	-/13/-	8.6/9.6/10.6	-/14/-	10/13/17.5	-	-	500	-	12/20	100
MBV7503	-/180/-	100/125/-	-/13/-	-9.6/10.6	-/14/-	10/13/-	-	-	500	-	12/20	1000
MBV7601	-/255/-	140/175/210	-/18.5/-	12.6/14.0/15.4	-/14/-	10/12.5/17	-	-	-	120	12/20	50
MBV7602	-/255/-	140/175/210	-/18.5/-	12.6/14.0/15.4	-/14/-	10/12.5/17	-	-	500	-	12/20	100
MBV7603	-/255/-	140/175/-	-/18.5/-	-14.0/15.4	-/14/-	10/12.5/-	-	-	500	-	12/20	1000
MBV7701	-/325/-	180/225/270	-/24/-	16.2/18.0/19.8	-/14/-	10/12.5/17	-	-	-	115	12/20	50
MBV7702	-/325/-	180/225/270	-/24/-	16.2/18.0/19.8	-/14/-	10/12.5/17	-	-	500	-	12/20	100
MBV7703	-/325/-	180/225/-	-/24/-	-18.0/19.8	-/14/-	10/12.5/-	-	-	500	-	12/20	1000
MBV7801	450/500/550	-/350/-	30.5/35.0/37.5	-/26.5/-	12/14/18	-/13/-	-	70	-	-	12/20	50
MBV7802	450/500/550	-/350/-	30.5/35.0/37.5	-/26.5/-	12/14/18	-/13/-	300	-	-	-	12/20	100
MBV7803	450/500/-	-/350/-	-/35.0/37.5	-/26.5/-	12/14/-	-/13/-	300	-	-	-	12/20	2000

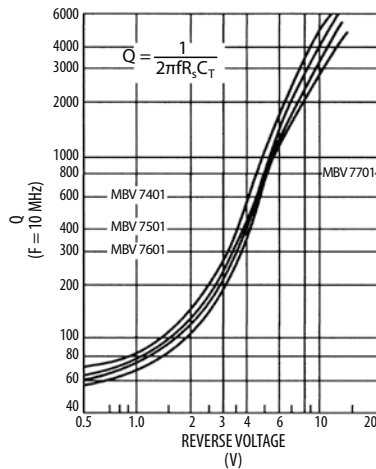
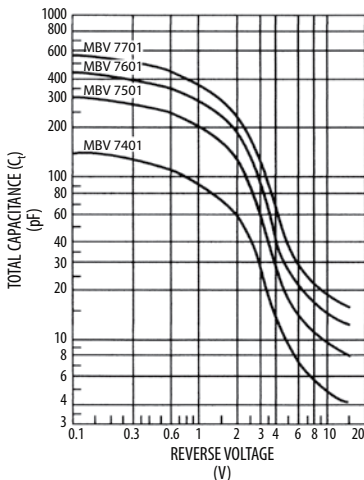

VHF HYPERABRUPT TUNING VARACTORS

Tuning Varactors: MBV 8000 – 8400 Series

Description

The Massachusetts Bay Technologies VHF tuning varactors are ion implanted highly reproducible hyperabrupt diodes which allow octave tuning of LC tanks up to 500 MHz and straightline frequency tuning over a 3 to 8 volt tuning range.

Packaging

Available in a wide range of package styles as well as chip form.

Electrical Specifications

$T_A = 25^\circ\text{C}$

Features: HF to VHF operation • Octave tuning from 4 to 20 volts • Ultra high Q • Linear frequency performance versus voltage

TYPE	C_T Diode Capacitance (pF) $f=1\text{ MHz}$			TR Tuning Ratio $f=1\text{ MHz}$		Q $V_R=4\text{ Vdc}$ $f=50\text{ MHz}$	V_{BR} (Vdc) $I_R=10\mu\text{A}$	I_R (nAde)		
	$V_R=4\text{ Vdc}$ MIN/TYP/MAX	$V_R=8\text{ Vdc}$ MIN/TYP/MAX	$V_R=20\text{ Vdc}$ MIN/TYP/MAX	C(4V)/C(8V) MIN/TYP/MAX	C(4V)/C(20V) MIN/TYP/MAX	MIN	MIN/TYP	$V_R=6\text{ Vdc}$ MAX	$V_R=10\text{ Vdc}$ MAX	$V_R=20\text{ Vdc}$ MAX
MBV8001	18/20/22	7.5/8.5/10.5	3.1/3.5/3.9	-	5.46/0.66	220	22/30	-	-	100
MBV8002	19/20/21	7.8/8.5/9.2	3.1/3.5/3.2	-	5.46/0.66	230	22/30	-	-	100
MBV8003	18/20/22	7.5/8.5/10.5	-	1.8/2.4/2.7	-	220	15/18	-	100	-
MBV8004	19/20/21	7.8/8.5/9.2	-	2.0/2.4/2.7	-	220	15/18	-	100	-
MBV8005	18/20/22	7.0/8.5/11.0	-	-	-	120	8/12	250	-	-
MBV8101	45/50/55	18/20/25	7.3/8.0/9.2	-	5.66/3.69	165	22/30	-	-	100
MBV8102	47.5/50/52.5	18/20/25	7.3/8.0/9.2	-	5.66/3.69	165	22/30	-	-	100
MBV8103	45/50/55	18/20/25	-	1.8/2.5/2.8	-	165	15/18	-	100	-
MBV8104	47.5/50/52.5	18.4/20/21.6	-	2.2/2.5/2.8	-	165	15/18	-	100	-
MBV8105	45/50/55	17/20/26	-	-	-	100	8/12	250	-	-
MBV8201	100/110/120	39/45/55	15/17/19	-	5.96/6.73	110	22/30	-	-	100
MBV8202	105/110/115	41.4/45/48.6	15/17/19	-	5.96/6.73	110	22/30	-	-	100
MBV8203	100/110/120	39/45/55	-	1.8/2.5/2.8	-	110	15/18	-	100	-
MBV8204	105/110/115	41.4/45/48.6	-	2.15/2.5/2.8	-	110	15/18	-	100	-
MBV8205	100/110/120	36/45/58	-	-	-	60	8/12	250	-	-
MBV8301	140/155/170	55/65/80	22.5/25/28	-	5.86/4.71	90	22/30	-	-	500
MBV8302	147/155/163	59.8/65/70.2	22.5/25/28	-	5.86/4.71	90	22/30	-	-	500
MBV8303	140/155/170	55/65/80	-	1.8/2.4/2.8	-	90	15/18	-	500	-
MBV8304	147/155/163	59.8/65/70.2	-	2.1/2.4/2.7	-	90	15/18	-	500	-
MBV8305	140/155/170	50/65/85	-	-	-	50	8/12	500	-	-
MBV8401	180/200/220	70/85/105	29/32/36	-	5.86/4.71	80	22/30	-	-	500
MBV8402	190/200/210	78/85/92	92/32/36	-	5.86/4.71	80	22/30	-	-	500
MBV8403	180/200/220	70/85/105	-	1.8/2.5/2.8	-	80	15/18	-	500	-
MBV8404	190/200/210	78/85/92	-	2.0/2.5/2.7	-	80	15/18	-	500	-
MBV8405	180/200/220	65/85/110	-	-	-	45	8/12	500	-	-

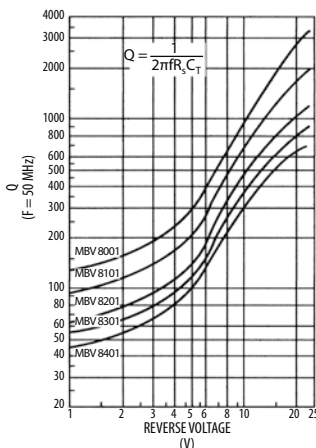
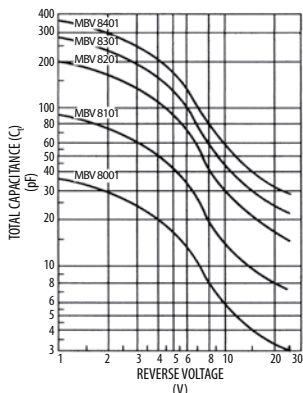

UHF HYPERABRUPT TUNING VARACTORS

Tuning Varactors: MBV 8500 - 8600

Description

The Massachusetts Bay Technologies UHF tuning Varactors offer higher Q's than their VHF counterparts, but have slightly lower capacitance ratios. These diodes are excellent for octave tuning up to 800 MHz and for straight line frequency tuning between 3 and 8 volts of bias.

Packaging

Available in a wide range of package styles as well as chip form.

Electrical Specifications

$T_A = 25^\circ\text{C}$

Features: VHF to UHF operation • Octave tuning from 3 to 20 volts • Ultra high Q • Linear frequency performance versus voltage

TYPE	C_T Diode Capacitance (pF) $f=1$ MHz			TR Tuning Ratio $f=1$ MHz		Q $V_R=3$ Vdc $f=50$ MHz	V_{BR} (Vdc) $I_R=10_\mu\text{A}$ dc	I_R (nAdc)		
	$V_R=3$ Vdc MIN/TYP/MAX	$V_R=8$ Vdc MIN/TYP/MAX	$V_R=20$ Vdc MIN/TYP/MAX	C(3V)/C(20V) MIN/TYP/MAX	C(3V)/C(8V) MIN/TYP/MAX	MIN	MIN/TYP	$V_R=6$ Vdc MAX	$V_R=10$ Vdc MAX	$V_R=20$ Vdc MAX
MBV8501	10.5/11.5/12.5	4.3/5.0/5.7	2.0/2.15/2.3	5.0/5.5/5.8	-	350	22/30	-	-	100
MBV8502	10.9/11.5/12.1	4.6/5.0/5.4	2.0/2.15/2.3	5.0/5.5/5.8	-	350	22/30	-	-	100
MBV8503	10.5/11.5/12.5	4.3/5.0/5.7	2.0/2.2/2.4	4.7/5.0/5.5	-	300	22/30	-	-	100
MBV8504	10.9/11.5/12.1	4.6/5.0/5.4	2.0/2.2/2.4	4.7/5.0/5.5	-	300	22/30	-	-	100
MBV8505	10.5/11.5/12.5	4.3/5.0/5.7	-	-	1.9/2.3/2.7	300	15/18	-	500	-
MBV8506	10.9/11.5/12.1	4.6/5.0/5.4	-	-	2.0/2.3/2.6	300	15/18	-	500	-
MBV8507	10.5/11.5/12.5	-	-	-	-	150	8/12	500	-	-
MBV8601	25/28/31	10/12/13.5	4.5/4.8/5.1	5.2/5.75/6.1	-	250	22/30	-	-	100
MBV8602	26.5/28/29.5	11/12/13	4.5/4.8/5.1	5.2/5.75/6.1	-	250	22/30	-	-	100
MBV8603	25/28/31	10/12/13.5	4.5/4.8/5.3	4.9/5.2/5.8	-	200	22/30	-	-	100
MBV8604	26.5/28/29.5	11/12/13	4.5/4.8/5.3	4.9/5.2/5.8	-	200	22/30	-	-	100
MBV8605	25/28/31	10/12/13.5	-	-	1.9/2.4/2.8	200	15/18	-	500	-
MBV8606	26.5/28/29.5	11/12/13	-	-	2.0/2.4/2.7	200	15/18	-	500	-
MBV8607	25/28/31	-	-	-	-	100	8/12	500	-	-

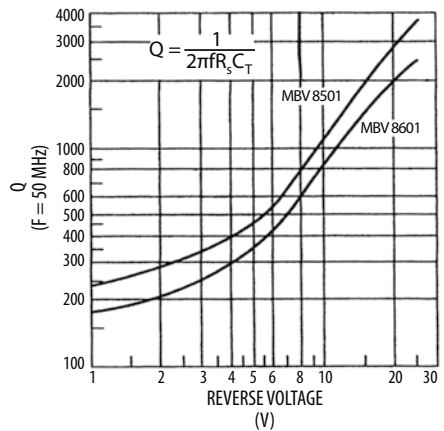
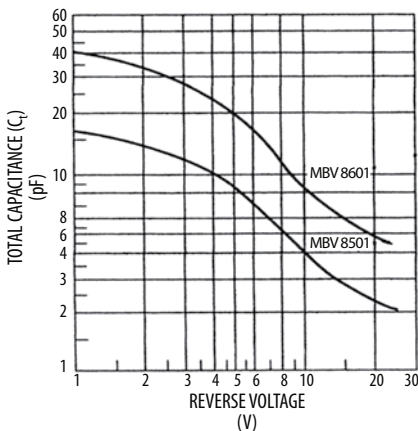

MICROWAVE HYPERABRUPT TUNING VARACTORS

Tuning Varactors: MBV 8700 Series

Description

The Massachusetts Bay Technologies MBV8700 series Microwave hyperabrupt tuning Varactors are silicon epitaxial mesa devices with high reliability glass passivation which ensures optimum VCO settling time and flat post tuning drift response. They also offer Q values well above ion implanted hyperabrupt diodes.

Applications

The MBV8700 series linear tuning Varactors are used in modulators, VCO's, filters and amplifiers for wide band tuning through K band.

Packaging

Available in a wide range of package styles as well as chip form.

Typical Performance

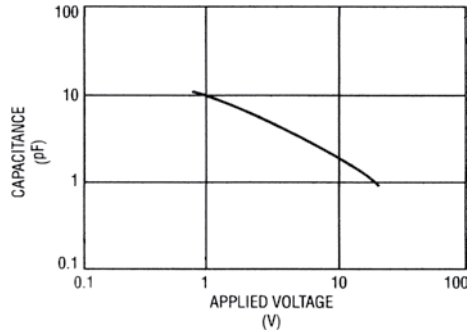

Electrical Specifications

$T_A = 25^\circ\text{C}$

Features: Octave tuning from 0 to 10 volts • Ultra high Q • Linear frequency performance versus voltage

TYPE	C_T Diode Capacitance (pF)				Q $V_R = 4V$	V_{BR} (Vdc) Mv	I_R (nAdc)
	$f = 1\text{MHz}$ $V_R = 4\text{Vdc}$		$f = 1\text{MHz}$ $V_R = 20\text{Vdc}$		$f = 50\text{MHZ}$ MIN	$I_R = 10\mu\text{A}$ Adc MIN	$V_R = 20\text{Vdc}$ MAX
	MIN	MAX	MIN	MAX			
MBV8700A	0.90	1.10	0.35	0.45	500	22	50
MBV8700B	1.35	1.65	0.45	0.55	500	22	50
MBV8700C	1.80	2.20	0.55	0.70	400	22	50
MBV8700D	2.70	3.30	0.70	0.90	400	22	50
MBV8700E	4.50	5.50	1.00	1.30	400	22	50

LOW COST UHF HYPERABRUPT TUNING VARACTORS

Tuning Varactors: MBV 8800 Series

Description

The Massachusetts Bay Technologies low cost hyperabrupts offer high Q's. These diodes are excellent for octave tuning up to 800 MHz and for straight line frequency tuning between 3 and 8 volts of bias.

Applications

The MBV8800 series linear tuning Varactors are used in modulators, VCO's, filters and amplifiers for wide band tuning through K band.

Case Style

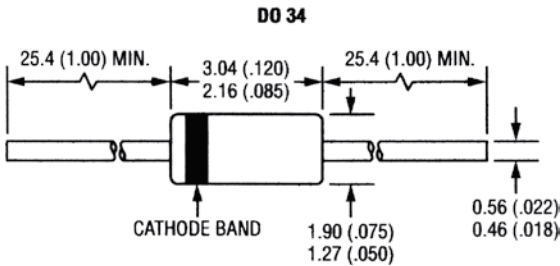

Packaging

Hermetic Glass Package

Typical Performance

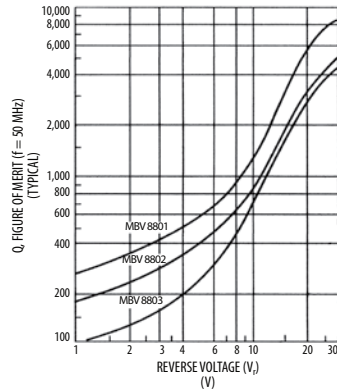
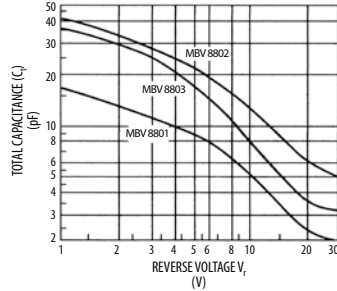

Electrical Specifications

Part Number	C _t Diode Capacitance (pf) F=1 MHz		T _r Tuning Ratio F=1 MHz C(3v)/V(25V) MIN/MAX	Q V _r =3Vdc F=50 MHz MIN/TYP	V _{br} (Vdc) I _r =10μA MIN	I _r (nA) V _r =28Vdc MAX	Cathode Strip	Case Style
	V _r =3Vdc MIN/MAX	V _r =25Vdc MIN/MAX						
MBV8801	9/13	2.0/2.3	4.5/5.8	300/415	30	50	White	D034
MBV8802	26/32	4.5/6.0	5.0/6.5	200/280	30	50	Yellow	D034
MBV8803	22.5/27.5	2.9/3.5	6.8/8.9	115/160	30	50	Green	D034

Maximum Ratings

Parameter	Symbol	Value	Units
Reverse Voltage	V _r	30	Vdc
Forward Current	I _f	200	mAdc
Power Dissipation at TA=25°C	P _d	400	mW
Derate Above 25°C		4.0	mW/°C
Maximum Junction Temperature	T _j	+125	°C
Storage Temperature	T _{stg}	-65 to =200	°C

Silicon Multiplier Diodes

Description

The Massachusetts Bay Technologies MPD series of silicon multiplier diodes are designed for efficient frequency conversion at output frequencies 150 MHz to 10 GHz. These diodes are intended for use in doublers or triplers and also for high power applications.

Applications

These series of Varactor diodes are intended for use in multipliers specifically designed transmitters for communication and telemetry applications.

Packaging

Available in a wide range of package styles as well as chip form.

TYPE NUMBER	POWER DISSIPATION PD(WATTS) @25°C	THERMAL RESISTANCE °C/W MAX	INPUT FREQ. F _{IN} MHz	POWER INPUT P _{IN} WATTS	OUTPUT FREQ. F _{OUT} MHz	POWER OUTPUT P _{OUT} (MIN) WATTS	BREAKDOWN VOLTAGE V _B (MIN) @10μA	SERIES RESISTANCE R _S @-6V F=50 MHz OHMS	CAPACITANCE (TOTAL) VR=6.0V F=1.0 MHz	
									MIN P _f	MAX P _f
1N5149	10.0	9.0	500	20.0	1000	11.0	80	0.25	5.0	5.0
1N5150	14.0	9.0	500	37.0	1000	24.0	80	0.25	5.0	20.0
1N5150A	21.0	6.0	500	37.0	1000	25.1	80	0.25	10.8	13.2
1N5151	5.5	23.0	1000	37.0	2000	6.0	75	0.5	5.0	7.5
1N5152	5.5	23.0	1000	12.0	2000	6.0	75	0.5	5.0	7.5
1N5153	5.5	23.0	1000	12.0	2000	6.0	75	0.5	5.0	7.5
1N5152A	8.4	15.0	1000	12.0	2000	7.2	75	0.5	5.4	6.6
1N5153A	8.4	15.0	1000	12.0	2000	7.2	75	0.5	5.4	6.6
1N5154	3.5	35.0	2000	5.0	6000	2.0	35	0.9	1.0	3.0
1N5155	3.5	35.0	2000	5.0	6000	2.0	35	0.9	1.0	3.0
1N5155A	6.2	20.0	2000	5.0	6000	2.0	35	0.9	1.71	2.09
1N5156	3.3	38.0	5000	2.6	10000	1.0	20	1.0	0.5	1.0
1N5157	3.3	38.0	5000	2.6	10000	1.0	20	1.0	0.5	1.0

MAXIMUM RATINGS

Storage Temperature:

-65°C to+200°C

Operating Temperature:

-55°C to+150°C

Super Power Multiplier Diodes

TYPE NUMBER	BREAKDOWN ¹ VOLTAGE V_R (MIN) @10 μ A (VOLTS)	JUNCTION ² CAPACITANCE @ -6V & 1 MHz (Pf)	MINIMUM ³ CUTOFF FREQUENCY OR MAXIMUM SERIES RESISTANCE (GHz OR OHMS)	TYPICAL MINORITY CARRIER LIFETIME 10mA/6mA (ns)	MAXIMUM TRANSITION TIME -10V/10mA (PS)	OUTPUT ⁴ FREQUENCY RANGE (GHz)	TYPICAL ⁵ EFFICIENCY AS A TRIPLER (%)	TYPICAL AVAILABLE OUTPUT POWER (WATTS)	MAXIMUM THERMAL RESISTANCE ($^{\circ}$ C/W)
MPD711A	140	18-26	0.30 π	450	5000	0.5-1.0	65	40	3
MPD712A	80	8-10	60	160	2000	1.0-2.5	65	24	7
MPD714A	80	4-5	90	130	2000	2.0-4.0	55	10	11
MPD716A	60	2.5-3.5	140	60	700	3.0-5.0	50	6	13
MPD718A	60	1.5-2.5	140	60	500	5.0-7.0	50	4	15
MPD720A	45	1.0-1.5	160	30	300	7.0-10.0	50	2.5	25

Standard Power Multiplier Diodes

TYPE NUMBER	BREAKDOWN ¹ VOLTAGE V_R (MIN) @10 μ A (VOLTS)	JUNCTION ² CAPACITANCE @ -6V & 1 MHz (Pf)	MINIMUM ³ CUTOFF FREQUENCY OR MAXIMUM SERIES RESISTANCE (GHz OR OHMS)	TYPICAL MINORITY CARRIER LIFETIME 10mA/6mA (ns)	MAXIMUM TRANSITION TIME -10V/10mA (PS)	OUTPUT ⁴ FREQUENCY RANGE (GHz)	TYPICAL ⁵ EFFICIENCY AS A TRIPLER (%)	TYPICAL AVAILABLE OUTPUT POWER (WATTS)	MAXIMUM THERMAL RESISTANCE ($^{\circ}$ C/W)
MPD801	200	18-26	0.35 π	450	10000	0.3-0.75	70	3-20	3
MPD802	175	18-26	0.35 π	400	8000	0.5-1.0	65	2-24	3
MPD803	150	10-20	40	350	5000	0.6-1.2	60	2-16	5
MPD804	120	8-10	60	210	3000	0.75-1.5	60	1-10	7
MPD805	100	8-10	60	180	2000	1.0-2.5	65	1-10	7
MPD806	120	4-5	90	200	3000	1.5-3.0	55	1-8	10
MPD807	100	4-5	90	170	2000	2.0-4.0	55	1-6	11
MPD808	80	4-6	110	180	925	2.0	-	2.0	-
MPD809	80	2.5-3.5	120	100	1000	3.0-5.0	50	0.5-4.0	13
MPD810	80	1.5-2.5	150	90	750	5.0-7.0	45	0.5-2.5	15
MPD811	60	1.5-2.5	150	60	400	5.0-8.0	45	0.3-1.5	15
MPD812	40	1.0-1.5	160	20	150	5.0-8.0	50	2.5	25
MPD813	40	0.5-0.7	175	180	150	8.0-12.0	40	0.1-0.6	50
MPD814	30	0.3-0.5	200	10	100	12.0-15.0	30	0.05-0.30	70
MPD815	6	0.15-0.2	350	3	-	15.0-25.0	15	0.05	300

NOTES:

1. Breakdown Voltage measured at $I_R=10\mu A$.
2. Junction Capacitance measured at -6 volts and 1 MHz.
3. Measured at -6 volts and 3.3 GHz.
4. Defined as the operable range, not instantaneous bandwidth.
5. Typical values when used as a tripler. Useful from 2 to 4 times multiplication.
6. Available in various package styles.

STEP RECOVERY DIODES

Step Recovery Diodes: MSR Series

Description

The Massachusetts Bay Technologies MSR series of Step Recovery Diodes are designed for use in low and moderate power multipliers with output frequencies of up to 20 GHz. They are also useful as efficient moderate power X2-X4 multipliers. MBT series of higher power step recovery diodes are normally useful in multipliers with multiplication ratios of X2 to X6 times. Diodes are available in various capacitance ranges for each of the 4 voltage ratings. These diodes represent the lowest transition time (snap time) available for each voltage rating.

Applications

This series of Step Recovery Diodes are used as harmonic generators for all orders of multiplication, X2 through X 20, for both narrow and wide bandwidths. Applications include VCO's, up converters, comb generators and frequency synthesizers.

Packaging

Available in a wide range of package styles as well as chip form.

Typical Performance

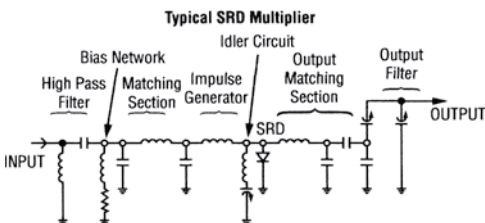
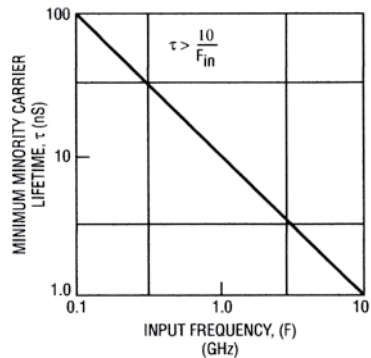
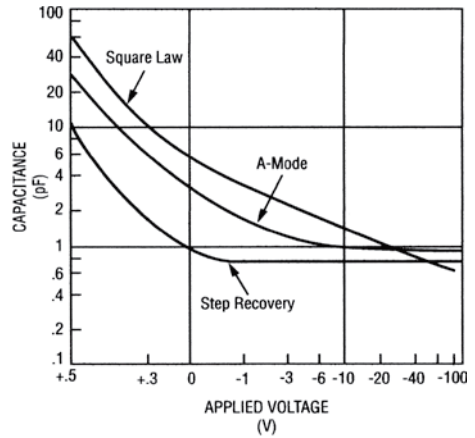

Step Recovery Diodes (SRDs)

TYPE NUMBER	BREAKDOWN VOLTAGE	JUNCTION (2) CAPACITANCE	MINORITY (3) CARRIER LIFETIME	TRANSITION (4) TIME
	V_B (MIN) (1) @ 10 μ A Volts	C_{J-6} PF	T_L (MIN) ns	T_t (MAX) ps
MSR10A	10	0.26-0.42	5	100
MSR10B	10	0.42-0.58	5	100
MSR10C	10	0.58-1.60	5	100
MSR10D	10	1.60-3.00	5	100
MSR13A	10	0.26-0.42	5	200
MSR13B	10	0.42-0.58	5	200
MSR13C	10	0.58-1.60	5	200
MSR13D	10	1.60-3.00	5	200
MSR15A	20	0.26-0.42	7	100
MSR15B	20	0.42-0.58	7	100
MSR15C	20	0.58-1.60	7	100
MSR15D	20	1.60-3.00	7	100
MSR17A	20	0.26-0.42	7	200
MSR17B	20	0.42-0.58	7	200
MSR17C	20	0.58-1.60	7	200
MSR17D	20	1.60-3.00	7	200
MSR19A	30	0.26-0.42	8	100
MSR19B	30	0.42-0.58	8	100
MSR19C	30	0.58-1.60	8	100
MSR19D	30	1.60-3.00	8	100
MSR23A	30	0.26-0.42	8	200
MSR23B	30	0.42-0.58	8	200
MSR23C	30	0.58-1.60	8	200
MSR23D	30	1.60-3.00	8	200
MSR25A	40	0.26-0.42	12	120
MSR25B	40	0.42-0.58	12	120
MSR25C	40	0.58-1.60	12	120
MSR25D	40	1.60-3.00	12	120
MSR27A	40	0.26-0.42	12	200
MSR27B	40	0.42-0.58	12	200
MSR27C	40	0.58-1.60	12	200
MSR27D	40	1.60-3.00	12	200
MSR29A	40	0.26-0.42	12	300
MSR29B	40	0.42-0.58	12	300
MSR29C	40	0.58-1.60	12	300
MSR29D	40	1.60-3.00	12	300
MSR33A	50	0.26-0.42	15	200
MSR33B	50	0.42-0.58	15	200
MSR33C	50	0.58-1.60	15	200
MSR33D	50	1.60-3.00	15	200
MSR35A	50	0.26-0.42	15	300
MSR35B	50	0.42-0.58	15	300
MSR35C	50	0.58-1.60	15	300
MSR35D	50	1.60-3.00	15	300
MSR37A	60	0.26-0.42	20	300
MSR37B	60	0.42-0.58	20	300
MSR37C	60	0.58-1.60	20	300
MSR37D	60	1.60-3.00	20	300

NOTES:

1. Breakdown Voltage measured at $I_R=10\mu A$.
2. Junction Capacitance measured at -6 volts and 1 MHz.
3. Minority Carrier Lifetime measured at $I_R=6\text{ m A}$ and $I_F=1.7\text{ I}_R$.
4. Transition Time is measured between the 20% and 80% points in the voltage recovery waveform. Test condition +10mA and -10 Volts.
5. All specifications are measured in package style PS-47.

MAXIMUM RATINGS

Storage Temperature:

-65°C to+200°C

Operating Temperature:

-55°C to+150°C

LOW-HIGH POWER PIN DIODES

Control Devices: MBP Series

Description

The Massachusetts Bay Technologies MBP series of PIN diodes are manufactured using high resistivity silicon epitaxial material grown on a highly doped low resistivity substrate. These PIN diodes are designed for fast switching speed, low loss microwave applications and for high power, high voltage RF applications. These devices are able to meet all visual criteria in space and military applications.

Applications

This series is used in switch applications which include high speed low power switches, medium power switches, high power switches and attenuators, digital phase shifters, duplexes and TR switches.

Packaging

Available in a wide range of package styles as well as chip form.

Typical Performance

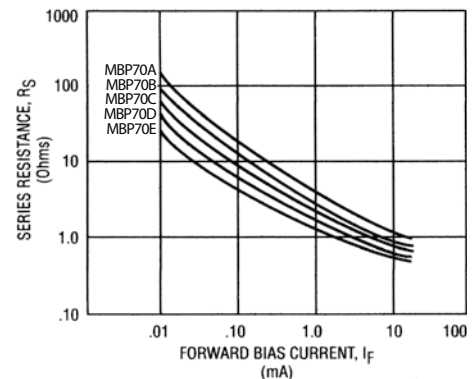
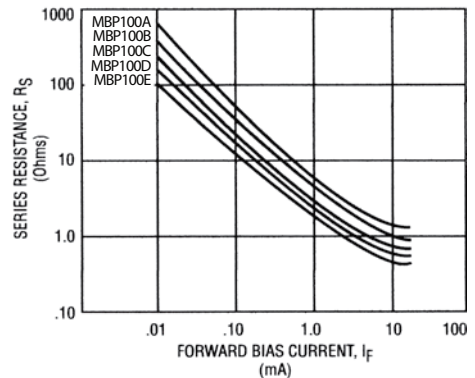
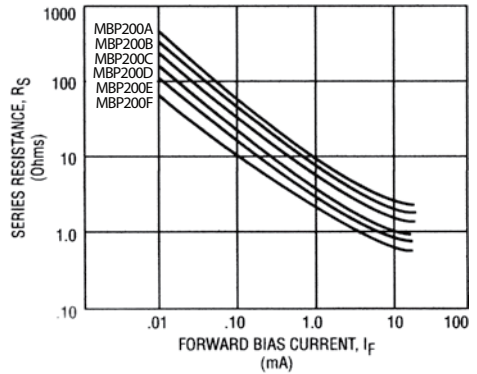

CONTROL DEVICES: MBP SERIES

Electrical Specifications

ULTRA FAST SWITCHING

PART NUMBER	V _{br} ¹ MIN (V)	C _{j-10 V²} MAX (pF)	T _r ³ TYP (nS)	φ _{jc} MAX °C/W	TS. Max. NS	RS@ 50 MA OHMS MAX	RS@ 10 MA OHMS TYP
MBP25A	25	.10	10	60	1.5	.70	1.0
MBP25B	25	.15	10	50	1.5	.55	0.8
MBP25C	25	.20	10	40	1.5	.45	0.7
MBP25D	25	.25	10	35	1.5	.40	0.6

FAST SWITCHING, LOW POWER

PART NUMBER	V _{br} ¹ MIN (V)	C _{j-10 V²} MAX (pF)	T _r ³ TYP (nS)	Δ _{jc} MAX °C/W	TS. MAX. NS	RS@ 75 MA OHMS MAX	RS@ 20 MA OHMS TYP
MBP70A	70	.05	60	80	5	0.9	1.2
MBP70B	70	.10	60	70	5	0.7	1.0
MBP70C	70	.15	60	60	5	0.6	0.9
MBP70D	70	.20	60	55	5	0.5	0.7
MBP70E	70	.25	60	50	5	0.45	0.5
MBP100A	100	.03	100	90	10	1.2	1.9
MBP100B	100	.07	100	80	10	0.9	1.5
MBP100C	100	.10	100	70	10	0.7	1.2
MBP100D	100	.15	100	60	10	0.6	1.0
MBP100E	100	.20	100	55	10	0.5	0.9
MBP100F	100	.30	100	50	15	0.45	0.8
MBP200A	200	.03	225	90	15	1.9	3.0
MBP200B	200	.07	225	80	15	1.2	2.2
MBP200C	200	.10	225	70	15	0.9	1.6
MBP200D	200	.15	225	60	15	0.8	1.0
MBP200E	200	.20	225	55	15	0.7	0.8
MBP200F	200	.30	225	50	15	0.6	0.7

NOTES:

- Reverse Breakdown Voltage measured at 10 μA.
- Junction Capacitance measured at -10 volts at 1 MHz.
- Minority Carrier lifetime measured with IF = 10 mA IR = 6mA.
- RF Switching speed measured from 90% to 10% and 10% to 90% transmission. Drive output - +20 mA and -4 volts, 200 mA spike with a rise time of 2 nS.
- Series Resistance is measured at 1 GHz using transmission loss techniques.

RATINGS

Operating Temperature:

-55°C to 150°C

Storage Temperature:

-65°C to 200°C

Reverse Breakdown:

from 25 volts to 500 volts

Voltage (V_{br}):

volts at 10 μA

Junction Capacitance (C_{j-10}):

from .03 pF to .5 pF at 10 volts

Switching Speed (TS):

from 1 nS to 25 nS

Lifetime (TI):

from 5 nS to 2.0 μS

Chip Thickness:

.004 - .007" thick

CONTROL DEVICES: MBP SERIES (cont.)

Electrical Specifications

MEDIUM POWER, GENERAL PURPOSE

PART NUMBER	V _{br1} MIN (V)	C _{j-10 V2} MAX (pF)	TL3 TYP (nS)	Δj _c MAX °C/W	TS. MAX. NS	RS@ 75 MA OHMS MAX	RS@ 20 MA OHMS TYP
MBP200G	200	.03	400	65	20	2.6	3.5
MBP200H	200	.07	400	60	20	1.5	2.2
MBP200I	200	.10	400	55	20	1.3	2.0
MBP200J	200	.15	400	50	20	1.0	1.9
MBP200K	200	.20	400	45	20	0.8	1.7
MBP200L	200	.30	400	40	20	0.7	1.4
MBP200M	200	.50	400	20	20	0.6	1.2
MBP200N	200	.03	600	60	25	2.6	3.5
MBP200O	200	.07	600	55	25	1.6	3.2
MBP200P	200	.10	600	50	25	1.2	2.0
MBP200Q	200	.15	600	45	25	0.9	1.9
MBP200R	200	.20	600	40	25	0.8	1.7
MBP200S	200	.30	600	35	25	0.7	1.4
MBP200T	200	.50	600	15	25	0.6	1.2

HIGH POWER SWITCHING & ATTENUATION

PART NUMBER	V _{br} ¹ MIN (V)	C _{j-10 V} ² MAX (pF)	T ₁ ³ TYP (nS)	R _s ⁵ @ 1 mA MAX (Ohms)	R _s ⁵ @ 10 mA MAX (Ohms)	R _s ⁵ @ 100 mA MAX (Ohms)	φj _c MAX °C/W
MBP250A	250	.05	1.0	25	10	2.0	20
MBP250B	250	.08	1.0	20	8	1.5	20
MBP250C	250	.10	1.0	15	6	1.2	20
MBP250D	250	.25	1.0	8	3.5	1.0	15
MBP250E	250	.03	1.5	6	2.0	0.8	15
MBP500A	500	.08	1.5	40	8	1.5	15
MBP500B	500	.10	1.5	15	5	1.2	15
MBP500C	500	.20	1.5	10	4	1.0	12
MBP500D	500	.30	2.0	8	3.5	0.8	10
MBP500E	500	.50	2.0	6	2.0	0.7	10

NOTES:

- Reverse Breakdown Voltage measured at 10 μA.
- Junction Capacitance measured at -10 volts at 1 MHz.
- Minority Carrier lifetime measured with IF = 10 mA 1R = 6mA.
- RF Switching speed measured from 90% to 10% and 10% to 90% transmission. Drive output - +20 mA and -4 volts, 200 mA spike with a rise time of 2 nS.
- Series Resistance is measured at 1 GHz using transmission loss techniques.

RATINGS

Operating Temperature:	-55°C to 150°C
Storage Temperature:	-65°C to 200°C
Reverse Breakdown:	from 25 volts to 500 volts
Voltage (V_{br}):	volts at 10 μA
Junction Capacitance (C_{j-10}):	from .03 pF to .5 pF at 10 volts
Switching Speed (TS):	from 1 nS to 25 nS
Lifetime (TI):	from 5 nS to 2.0 μS
Chip Thickness:	.004 - .007" thick

CONTROL DEVICES: MBP SERIES (cont.)

Electrical Specifications

Packaging Styles: Chips

Operating Frequency 1.0 - 1000.0 MHz

PIN CHIPS

PART NUMBER	$V_{b1}=10 \mu\text{A}$ Volts MIN	CT $V=100 \text{ V}$ $F=1 \text{ MHz}$ pF MAX	TL=10 mA usec MIN	RS@ 100 MA, $F=100 \text{ MHz}$ OHMS MAX	Thermal Resistance (C/W) Typical
MBP500F	500	0.20	1.00	0.60	20
MBP500H	500	0.35	2.00	0.45	15
MBP500I	500	0.70	3.00	0.30	10
MBP1000A	1000	0.30	3.00	1.00	15
MBP1000B	1000	0.60	4.00	0.70	10
MBP1000C	1000	1.30	5.00	0.40	7

Operating Temperature:

-55°C to 150°C

Storage Temperature:

-65°C to 200°C

Reverse Breakdown:

from 25 volts to 1500 volts

Voltage (V_{br}):

volts at 10 μA

LIMITER DIODES

Description

The Massachusetts Bay Technologies MLD series limiter diodes are specifically processed PIN diodes designed for use in passive or active limiters over the entire range of frequencies from 100 MHz to beyond 20 GHz. The MLD series limiter diodes are offered for flexibility in design of low (lowest V_b , fastest turn-on time), medium and high (highest V_b , slowest turn-on time) power limiters.

Applications

The MLD series limiters are for use in waveguides, coax, microstrip or stripline. Single or cascade devices may be used depending on power levels.

Packaging

Available in a wide range of package styles as well as chip form.

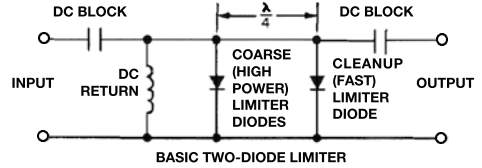

Chip Electrical Parameters

$T_A = 25^\circ\text{C}$

Type Number	V_b MIN (V)	C_{j0} TYP (pF)	C_{j6} MAX (pF)	R_s TYP @ 10mA (W)	T_L TYP (ns)	θ_p TYP ($^\circ\text{C}/\text{W}$)	θ_{cw} ($^\circ\text{C}/\text{W}$)
MLD5113	20	0.20	0.15	1.5	5	20	100
MLD5114	-	0.50	0.30	1.2	10	12	80
MLD5115	45	0.20	0.15	1.5	10	15	80
MLD5116	-	0.50	0.30	1.2	15	10	60
MLD5117	-	0.70	0.50	1.0	20	6	40
MLD5118	120	0.20	0.15	1.5	50	1.2	40
MLD5119	-	0.60	0.30	1.0	50	0.5	20
MLD5120	-	0.80	0.50	0.5	100	0.3	15
MLD5121	15	0.12	0.10	2.0	5	30	120
MLD5122	-	0.20	0.15	1.5	5	20	80
MLD5123	30	0.12	0.10	2.0	7	20	100
MLD5124	-	0.20	0.15	1.5	7	15	70

Typical Limiter Performance Ratings

$T_A = 25^\circ\text{C}$

Type Number	PEAK P_{in} MAX (@ 1.0 μs) (dBm)	LEAKAGE P_{out} TYP (dBm)	THRESHOLD TYP (dBm)	INSERTION LOSS TYP (db)	CW POWER IN MAX (W)
MLD5113	+50	+22	+10	0.1	2
MLD5114	+53	+24	+10	0.2	3
MLD5115	+53	+27	+15	0.1	3
MLD5116	+56	+29	+15	0.2	4
MLD5117	+59	+31	+15	0.2	5
MLD5118	+60	+39	+20	0.1	5
MLD5119	+63	+41	+20	0.2	10
MLD5120	+66	+44	+20	0.2	15
MLD5121	+47	+19	+7	0.1	2
MLD5122	+50	+22	+7	0.1	3
MLD5123	+47	+24	+12	0.1	3
MLD5124	+50	+27	+12	0.1	4

Note: Available in various package styles.

PERFORMANCE

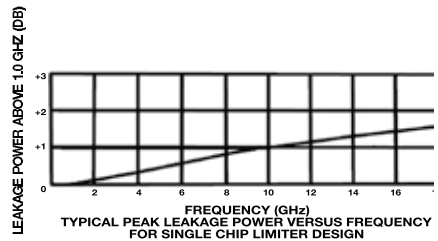
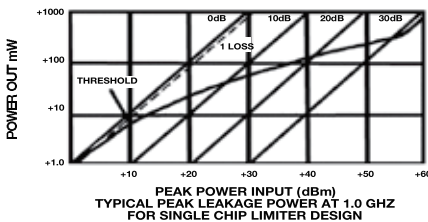

Operating Temperature:
Max Leakage Current:

-55°C to 150°C
0.5 ma @ 88% of min. rated breakdown

BEAM LEAD PIN DIODES

Control Devices: MBL Series Mesa and Planar Beam Lead PIN Diodes

Description

The Massachusetts Bay Technologies MBL series beam lead diodes are designed for low loss, low capacitance, high isolation microwave switch and attenuator circuits. The beam lead construction offers a high degree of ruggedness with a beam lead pull strength in excess of 6 grams and mechanical strength and uniformity unique to silicon beam lead diodes.

Applications

The MBL series beam lead diodes are used in stripline and microstrip circuits that require, low to medium power series switching and attenuating.

Packaging

- Beam Lead

Typical Performance

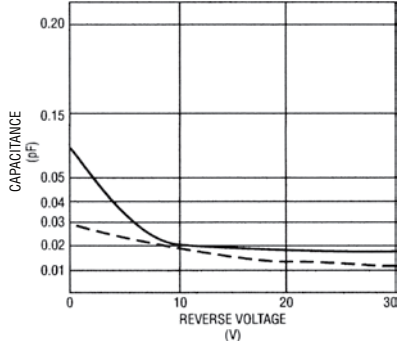

ABSOLUTE MAXIMUM RATINGS:

- Storage Temperature:** -65°C to +175°C
- Operating Temperature:** -65°C to +150°C
- Power Dissipation:** 250 mW
- Beam Terminal Strength:** Planar- 4 grams minimum/Mesa- 6 grams minimum

Planar Beam Lead Pin

TYPE NUMBER	V _B ¹ MIN (VOLTS)	SERIES ² RESISTANCE R _S MAX (OHMS)	JUNCTION ³ CAPACITANCE C _J -50V, MAX (pF)	MINORITY ⁴ CARRIER LIFETIME T _L TYP (ns)	RF ⁵ SWITCHING TIME TS, TYP (ns)
MBL5201	100	4.0	0.020	100	25
MBL5202	100	3.5	0.030	100	25
MBL5203	100	4.0	0.040	100	25
MBL5204	100	3.0	0.060	100	25

Mesa Beam Lead Pin

TYPE NUMBER	BREAKDOWN ¹ VOLTAGE V _B MIN (VOLTS)	SERIES ² RESISTANCE R _S +50mA, MAX (OHMS)	JUNCTION ³ CAPACITANCE C _J -50V, MAX (pF)	MINORITY ⁴ CARRIER LIFETIME T _L TYP (ns)	RF ⁵ SWITCHING TIME, TS (ns)
MBL5205	100	3.5	0.025	70	5ns OFF
MBL5206	100	3.0	0.030	70	5ns OFF
MBL5207	100	3.0	0.040	70	5ns OFF
MBL5208	100	2.5	0.060	70	5ns OFF

High Speed Mesa Beam Lead Pin

TYPE NUMBER	BREAKDOWN ¹ VOLTAGE V _B MIN (VOLTS)	SERIES ² RESISTANCE R _S +50mA, MAX (OHMS)	JUNCTION ³ CAPACITANCE C _J -10V, MAX (pF)	MINORITY ⁴ CARRIER LIFETIME T _L TYP (ns)	RF ⁵ SWITCHING TIME, TS, TYP (ns)
MBL5209	50	1.8	0.07	50	3
MBL5210	40	1.2	0.12	40	3
MBL5211	30	1.0	0.15	25	2

NOTES:

1. Breakdown voltage is measured at 10μA.
2. Series Resistance is calculated from insertion loss measurements at 3 GHz, 50mA.
3. Junction Capacitance is calculated from isolation measurements at 9 GHz.
4. Minority Carrier Lifetime is measured at I_F=10mA, I_R=6mA.
5. RF Switching Time is measured from RF transmission, 90% to 10%, in series configuration.
6. Available in package styles PS-6 and PS-7.

Massachusetts Bay Technologies, Inc. • 378 Page Street, Stoughton, MA 02072

LOW BARRIER SCHOTTKY MIXER DIODES

Schottky Diodes: MSL Series

Description

The Massachusetts Bay Technologies MSL series of Low Barrier Schottky diodes are metal semiconductor junction devices. The forward I-V of Schottky diodes is determined by the junction metal used. For every different metal selection there is a different barrier height.

Applications

The MSL series of Low barrier Schottky diodes are used in mixers, doublers and modulators.

Packaging

Available in a wide range of package styles as well as chip form.

Typical Performance

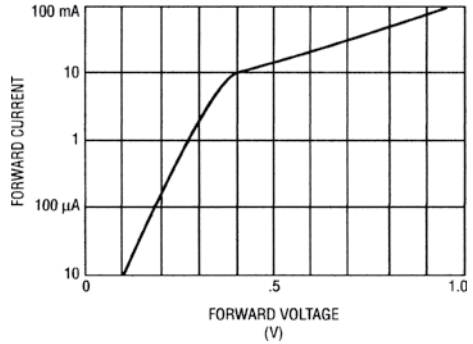

Electrical Specifications

Part Number	Breakdown Voltage @10μA MIN (V)	Forward Voltage @1mA MAX (V)	Junction Capacitance @0Vdc 1MHz TYP (pF)	Series Resistance @5 mA TYP (Ohms)	Tangential Signal Sensitivity TYP (db)
MSL1201	2.0	0.25	0.08	16.0	-55
MSL1202	2.0	0.28	0.10	16.0	-52
MSL1203	2.0	0.30	0.12	14.0	-50
MSL1204	2.0	0.32	0.14	10.0	-48
MSL1205	3.0	0.25	0.08	16.0	-55
MSL1206	3.0	0.28	0.10	16.0	-52
MSL1207	3.0	0.30	0.12	14.0	-50
MSL1208	3.0	0.32	0.14	10.0	-48
MSL1209	4.0	0.25	0.08	16.0	-55
MSL1210	4.0	0.28	0.10	16.0	-52
MSL1211	4.0	0.30	0.12	14.0	-50
MSL1212	4.0	0.32	0.14	10.0	-48
MSL1213	5.0	0.25	0.08	16.0	-55
MSL1214	5.0	0.28	0.10	16.0	-52
MSL1215	5.0	0.30	0.12	14.0	-50
MSL1216	5.0	0.32	0.14	10.0	-48

Operating Temperature:

-55°C to 150°C

Storage Temperature:

-65°C to 200°C

Power Dissipation @25°C:

250mW

(Derate linearly to zero at 150°C)

MEDIUM BARRIER SCHOTTKY MIXER DIODES

Schottky Diodes: MSM Series

Description

The Massachusetts Bay Technologies MSM series of Medium Barrier Schottky diodes are metal semiconductor junction devices. The forward I-V of Schottky diodes is determined by the junction metal used. For every different metal selection there is a different barrier height.

Applications

The MSM series of Medium barrier Schottky diodes are used in mixers, doublers and modulators.

Packaging

Available in a wide range of package styles as well as chip form.

Typical Performance

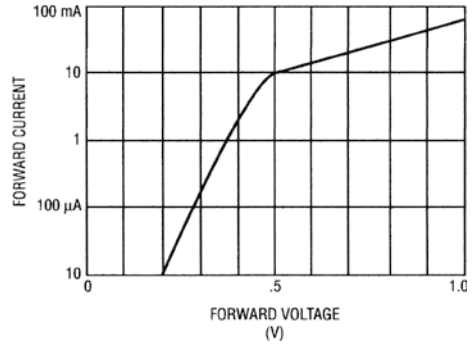

Electrical Specifications

Part Number	Breakdown Voltage @10μA MIN (V)	Forward Voltage @1mA MAX (V)	Junction Capacitance @0Vdc 1MHz TYP (pF)	Series Resistance @5 mA TYP (Ohms)	Tangential Signal Sensitivity TYP (db)
MSM1301	3.0	0.350	0.08	15.0	-52
MSM1302	3.0	0.350	0.10	15.0	-50
MSM1303	3.0	0.350	0.12	12.0	-48
MSM1304	3.0	0.350	0.14	8.0	-45
MSM1305	4.0	0.375	0.08	15.0	-52
MSM1306	4.0	0.375	0.10	15.0	-50
MSM1307	4.0	0.375	0.12	12.0	-48
MSM1308	4.0	0.375	0.14	8.0	-45
MSM1309	5.0	0.400	0.08	15.0	-52
MSM1310	5.0	0.400	0.10	15.0	-50
MSM1311	5.0	0.400	0.12	12.0	-48
MSM1312	5.0	0.400	0.14	8.0	-45
MSM1313	6.0	0.450	0.08	15.0	-52
MSM1314	6.0	0.450	0.10	15.0	-50
MSM1315	6.0	0.450	0.12	12.0	-48
MSM1316	6.0	0.450	0.14	8.0	-45

Operating Temperature:

-55°C to 150°C

Storage Temperature:

-65°C to 200°C

Power Dissipation @25°C:

250mW

(Derate linearly to zero at 150°C)

HIGH BARRIER SCHOTTKY MIXER DIODES

Schottky Diodes: MSH Series

Description

The Massachusetts Bay Technologies MSH series of High Barrier Schottky diodes are metal semiconductor junction devices. The forward I-V of Schottky diodes is determined by the junction metal used. For every different metal selection there is a different barrier height.

Applications

The MSH series of High barrier Schottky diodes are used in mixers, doublers and modulators.

Packaging

Available in a wide range of package styles as well as chip form.

Typical Performance

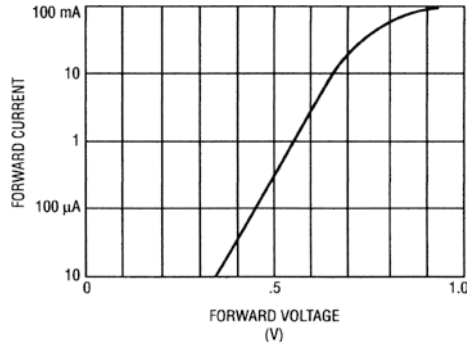

Electrical Specifications

Part Number	Breakdown Voltage @10μA MIN (V)	Forward Voltage @1mA MAX (V)	Junction Capacitance @0 Vdc 1MHz TYP (pF)	Series Resistance @5 mA TYP (Ohms)	Tangential Signal Sensitivity TYP (db)
MSH1401	4.0	0.475	0.08	10.0	-52
MSH1402	4.0	0.475	0.10	10.0	-58
MSH1403	4.0	0.475	0.12	8.0	-48
MSH1404	4.0	0.475	0.14	6.0	-45
MSH1405	5.0	0.500	0.08	10.0	-52
MSH1406	5.0	0.500	0.10	10.0	-50
MSH1407	5.0	0.500	0.12	8.0	-48
MSH1408	5.0	0.500	0.14	6.0	-45
MSH1409	6.0	0.525	0.08	10.0	-52
MSH1410	6.0	0.525	0.10	10.0	-50
MSH1411	6.0	0.525	0.12	8.0	-45
MSH1412	6.0	0.525	0.14	6.0	-45
MSH1413	8.0	0.550	0.08	10.0	-52
MSH1414	8.0	0.550	0.10	10.0	-50
MSH1415	8.0	0.550	0.12	8.0	-48
MSH1416	8.0	0.550	0.14	6.0	-45

Operating Temperature:

-55°C to 150°C

Storage Temperature:

-65°C to 200°C

Power Dissipation @25°C:

250mW

(Derate linearly to zero at 150°C)

ZERO BIAS SCHOTTKY MIXER DIODES

Schottky Diodes: MBZ Series

Description

The Massachusetts Bay Technologies MBZ series Zero Bias Schottky Detector diodes are designed for use in power monitor and video detectors. The choice of barrier metal and processes provide a broad selection of video impedance.

Applications

The Zero Bias Schottky Detector diodes are used in narrow bandwidth video detectors, ECM receivers, waveguide, coaxial and stripline applications.

Packaging

Available in a wide range of package styles as well as chip form.

Typical Performance

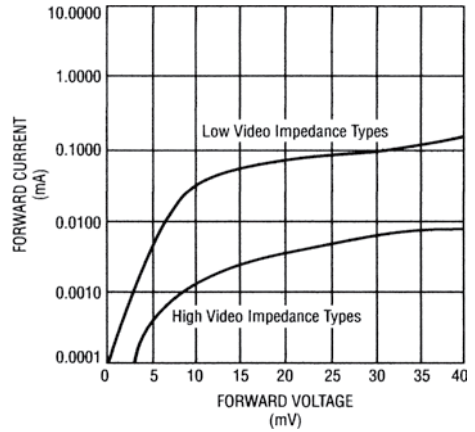

Electrical Specifications

Part Number	Breakdown Voltage @100 μ A MIN (V)	Forward Voltage @1mA MAX (V)	Junction Capacitance @0 Vdc 1MHz TYP (pF)	Video Resistance TYP (Ohms)	Tangential Signal Sensitivity TYP (db)
MBZ100	3.0	0.3	0.20	3500	-42
MBZ101	3.0	0.3	0.30	3500	-45
MBZ102	3.0	0.3	0.35	3500	-47
MBZ103	3.0	0.3	0.40	3500	-50
MBZ104	4.0	0.3	0.20	5000	-45
MBZ105	4.0	0.3	0.30	5000	-45
MBZ106	4.0	0.3	0.35	5000	-47
MBZ107	4.0	0.3	0.40	5000	-50
MBZ108	5.0	0.3	0.20	8000	-50
MBZ109	5.0	0.3	0.30	8000	-55
MBZ110	5.0	0.3	0.40	8000	-58

Operating Temperature:

-55°C to 150°C

Storage Temperature:

-65°C to 200°C

Power Dissipation @25°C:

100mW

(Derate linearly to zero at 150°C)

GENERAL PURPOSE SCHOTTKY MIXER DIODES

Description

The Massachusetts Bay Technologies MGS series General Purpose Schottky Barrier diodes are specially designed to achieve a high breakdown voltage. This series of diodes can be used in the UHF and VHF frequency bands.

Applications

The General Purpose Schottky diodes are designed for use in high level mixers and detectors, fast switching, and up converters.

Packaging

Available in a wide range of package styles as well as chip form.

Typical Performance

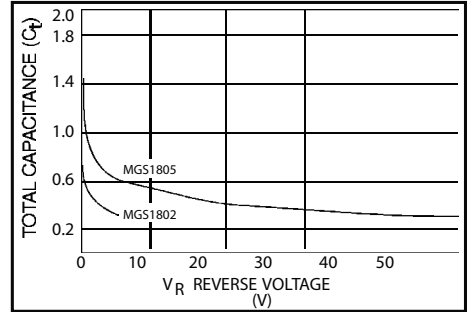

Electrical Characteristics

TYPE NUMBER	BREAKDOWN VOLTAGE	FORWARD VOLTAGE	JUNCTION CAPACITANCE	LEAKAGE CURRENT
	V_B 10mA MIN (V)	1mA TYP (V)	@0 Vdc 1MHz MAX (pF)	80% V_b MAX (nA)
MGS1801	8.0	0.34	1.2	100.0
MGS1802	8.0	0.34	1	100.0
MGS1803	20.0	0.55	1.2	100.0
MGS1804	20.0	0.41	1	100.0
MGS1805	70.0	0.41	2	200.0
MGS1806	70.0	0.41	1.2	200.0

1. Available in various package styles.

ABSOLUTE MAXIMUM RATINGS:

Storage Temperature: -55°C to -150°C
 Operation Temperature: -65°C to +150°C

LOW BARRIER SCHOTTKY RING QUADS

Schottky Diodes: MLQ Series

Description

The Massachusetts Bay Technologies MLQ series of low barrier ring quads consists of four closely matched diodes connected in a ring configuration. These monolithic devices are matched by capacitance, forward voltage and series resistance.

Applications

The low barrier Schottky ring quads are used in doublers, double balanced mixers and modulators.

Packaging

Beam Lead.

Diode Ring Circuit

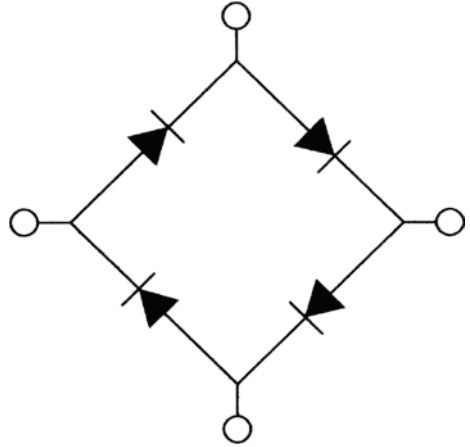

Electrical Specifications

Part Number	Breakdown Voltage @10 μ A MIN (V)	Forward Voltage @1mA MAX (mVdc)	Delta Forward Voltage @1mA MAX (mV)	Total Capacitance @0 Vdc 1MHz TYP (pF)	R _D TYP @5 mA (Ohms)
MLQ700	2.0	250	25	0.12	12
MLQ701	2.0	270	25	0.15	14
MLQ702	2.0	290	25	0.15	18
MLQ703	2.0	310	25	0.15	18
MLQ704	2.0	330	25	0.18	20
MLQ705	2.0	350	25	0.20	20

Operating Temperature:

-55°C to 150°C

Storage Temperature:

-65°C to 200°C

Power Dissipation @25°C:

100mW

(Derate linearly to zero at 150°C)

MEDIUM BARRIER SCHOTTKY RING QUADS

Schottky Diodes: MMQ Series

Description

The Massachusetts Bay Technologies MMQ series of medium barrier ring quads consists of four closely matched diodes connected in a ring configuration. These monolithic devices are matched by capacitance, forward voltage and series resistance.

Applications

The medium barrier Schottky ring quads are used in doublers, double balanced mixers and modulators.

Packaging

Beam Lead.

Diode Ring Circuit

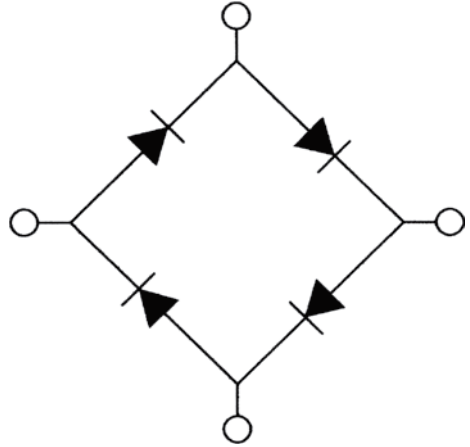

Electrical Specifications

Part Number	Breakdown Voltage @10 μ A MIN (V)	Forward Voltage @1mA MAX (mVdc)	Delta Forward Voltage @1mA MAX (mV)	Total Capacitance @0 Vdc 1MHz TYP (pF)	R _D TYP @5 mA (Ohms)
MMQ800	3.0	370	25	0.12	12
MMQ801	3.0	390	25	0.15	12
MMQ802	3.0	410	25	0.15	14
MMQ803	3.0	430	25	0.15	14
MMQ804	3.0	450	25	0.18	18
MMQ805	3.0	470	25	0.20	20

Operating Temperature:

-55°C to 150°C

Storage Temperature:

-65°C to 200°C

Power Dissipation @25°C:

250mW

(Derate linearly to zero at 150°C)

HIGH BARRIER SCHOTTKY RING QUADS

Schottky Diodes: MHQ Series

Description

The Massachusetts Bay Technologies MHQ series of high barrier ring quads consists of four closely matched diodes connected in a ring configuration. These monolithic devices are matched by capacitance, forward voltage and series resistance.

Applications

The high barrier Schottky ring quads are used in doublers, double balanced mixers and modulators.

Packaging

Beam Lead.

Diode Ring Circuit

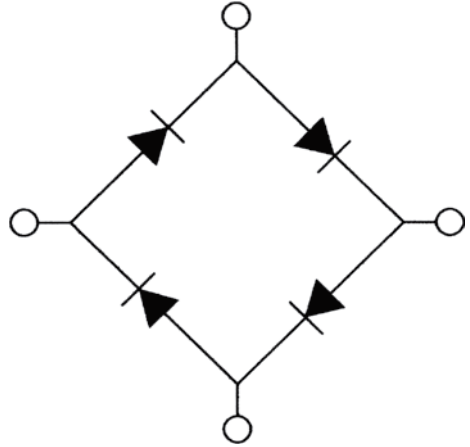

Electrical Specifications

Part Number	Breakdown Voltage @10 μ A MIN (V)	Forward Voltage @1mA MAX (mVdc)	Delta Forward Voltage @5 mA MAX (mV)	Total Capacitance @0 Vdc 1MHz TYP (pF)	R _D TYP @5 mA (Ohms)
MHQ900	5.0	490	25	0.12	12
MHQ901	5.0	510	25	0.12	12
MHQ902	5.0	530	25	0.15	14
MHQ903	5.0	550	25	0.15	14
MHQ904	5.0	570	25	0.18	18
MHQ905	5.0	590	25	0.20	20

Operating Temperature:

-55°C to 150°C

Storage Temperature:

-65°C to 200°C

Power Dissipation @25°C:

250mW

(Derate linearly to zero at 150°C)

PHASE DETECTORS

MSPD Series

Description

The Massachusetts Bay Technologies MSPD series Phase Detector is a hybrid circuit design.

The detectors are available from 2-24 GHz and can be customized.

Applications

Phase Detectors are used for VCO and DRO's in the 500 MHz reference frequencies.

Packaging

Phase Detector Package.

Packaging

- PS-99

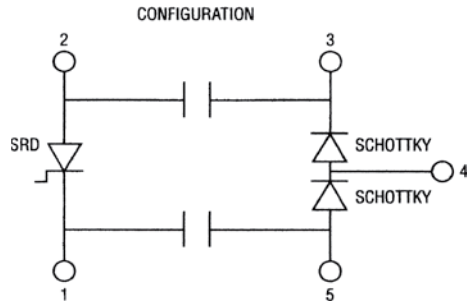

Electrical Specifications

SAMPLING PHASE DETECTORS

Part Number		Lifetime T _I	Transition T _t	Capacitance C _J	Breakdown V _b	Resistance R _s
MSPD-001-99	2-6 GHz Step Recovery Diode Chip Capacitors Schottky Pair	17 nS	100 pS	.60 pF ¹ .50 ² .20 ²	35 Vdc 100 Vdc 3 Vdc	8.0 Ohms
MSPD-002-99	8-12 GHz Step Recovery Diode Chip Capacitors Schottky Pair	12 nS	80 pS	.60 pF ¹ .50 ² .15 ²	35 Vdc 100 Vdc 3 Vdc	10.0 Ohms
MSPD-003-99	14-16 GHz Step Recovery Diode Chip Capacitors Schottky Pair	10 nS	50 pS	.50 pF ¹ .50 ² .10 ²	20 Vdc 100 Vdc 4 Vdc	12.0 Ohms
MSPD-004-99	18-24 GHz Step Recovery Diode Chip Capacitors Schottky Pair	8 nS	45 pS	.35 pF ¹ .50 ² .09 ²	15 Vdc 100 Vdc 4 Vdc	12.0 Ohms

NOTES:

1. C_J @ -6 Vdc 1MHz
2. C_J @ 0 Vdc 1MHz

HIGH PERFORMANCE SAMPLING PHASE DETECTORS

Part Number	Max Operating Frequency GHz	Monolithic Schottky Diode Pair			Beam Lead Coupling Capacitors C _T pf	Beam Lead Step Recovery Diode			
		V _F @1 mA mV	R _S Ω	Typ C _J @ 0V pf		C _J @ 6V pf	T _L nS	T _t pS	V _B V
MSPD-005-99	4	250	3	0.40	1.0	0.35	25	59	14
MSPD-006-99	12	275	6	0.25	0.6	0.35	25	59	14
MSPD-007-99	18	300	10	0.12	0.5	0.35	25	59	14
MSPD-008-99	20	325	14	0.08	0.5	0.35	25	59	14
MSPD-009-99	4	350	3	0.40	1.0	0.35	25	59	14
MSPD-010-99	12	400	6	0.25	0.6	0.35	25	59	14
MSPD-011-99	18	425	10	0.12	0.5	0.35	25	59	14
MSPD-012-99	20	450	14	0.08	0.5	0.35	25	59	14
MSPD-013-99	4	575	3	0.40	1.0	0.35	25	59	14

RATINGS

Operating Temperature:

-55°C to 150°C

Storage Temperature:

-65°C to 200°C

Reverse Voltage:

See Voltage Rating

Massachusetts Bay Technologies, Inc. • 378 Page Street, Stoughton, MA 02072

Tel: 781-344-8809 • Fax: 781-341-8177 • Email: sales@massbaytech.com • www.massbaytech.com

Ka BAND POINT CONTACT MIXER DIODES

Point Contact Diodes: 1N Series

Description

The Massachusetts Bay Technologies 1N series of Point Contact Mixer diodes is designed for applications through KA-Band. Each device in this series is in a coaxial package specially designed for low noise figure performance. These diodes employ epitaxial silicon optimized for low noise figure and uniformity. These devices are suitable for use in waveguide, coaxial and stripline applications.

Applications

The 1N Series of Point Contact Mixers are suitable for use in waveguide, coaxial and stripline applications.

Packaging

- Coaxial

Typical Performance

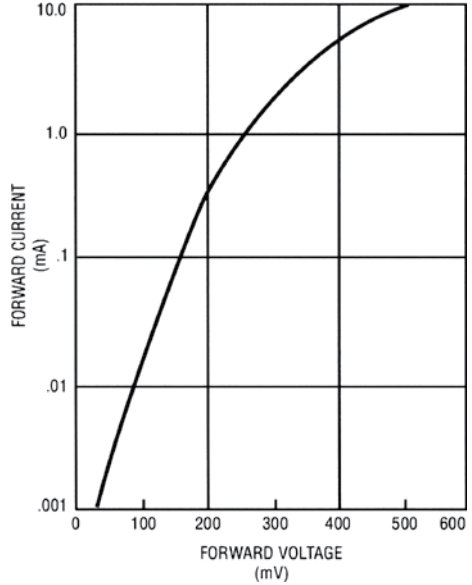

Electrical Specifications

Part Number	Noise Figure	VSWR	IF Impedance	Conversion Loss	Case Style
	34.860 GHz LO = 1.0 mW RI = 100 Ohms MAX (dB)	34.860 GHz LO = 1.0 mW RI = 100 Ohms MAX (Ratio)	34.860 GHz LO = 1.0 mW RI = 100 Ohms MIN/MAX (Ohms)	34.860 GHz LO = 1.0 mW RI = 100 Ohms MAX (dB)	
1N53	—	—	350 - 800	—	PS103
1N53A	11.0	—	350 - 800	—	PS103
1N53B	10.0	1.6	350 - 800	9.0	PS103
1N53C	9.5	1.6	350 - 800	8.5	PS103
1N53D	8.5	1.6	350 - 800	7.5	PS103

Part Number	Noise Figure	VSWR	IF Impedance	Conversion Loss	Case Style
	16.0 GHz LO = 1.0 mW RI = 100 Ohms MAX (dB)	16.0 GHz LO = 1.0 mW RI = 100 Ohms MAX (Ratio)	16.0 GHz LO = 1.0 mW RI = 100 Ohms MIN/MAX (Ohms)	16.0 GHz LO = 1.0 mW RI = 100 Ohms MAX (dB)	
1N78	12.0	—	325 - 650	—	PS102
1N78A	12.0	—	325 - 650	—	PS102
1N78B	10.0	1.6	325 - 650	9.0	PS102
1N78C	9.5	1.6	325 - 650	8.5	PS102
1N78D	8.5	1.6	325 - 650	7.5	PS102
1N78E	8.0	1.5	325 - 650	7.0	PS102
1N78F	7.5	1.5	325 - 650	6.5	PS102
1N78G	7.0	1.5	325 - 650	6.0	PS102

Operating Temperature:

-55°C to 150°C

Storage Temperature:

-65°C to 200°C

S-X BAND POINT CONTACT MIXER DIODES

Point Contact Diodes: 1N Series

Description

The Massachusetts Bay Technologies 1N series of Point Contact Mixer diodes is designed for applications from S Band through X-Band. Each device in this series is in a cartridge package specially designed for low noise figure performance. These diodes employ epitaxial silicon optimized for low noise figure and wide bandwidth and are used in single or multiple device mixer applications.

Applications

The 1N series of Point Contact Mixers is suitable for use in waveguide, coaxial and stripline applications.

Packaging

- Cartridge Style

Typical Performance

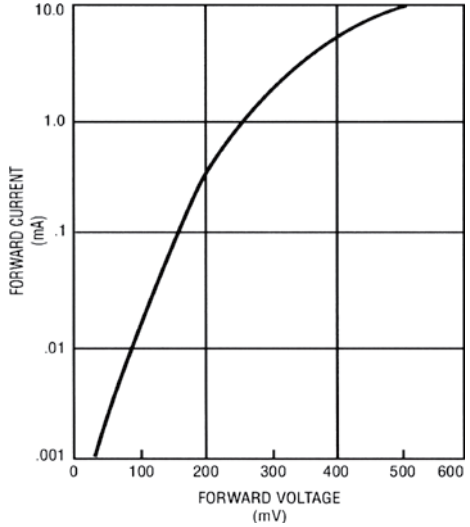

Electrical Specifications

Part Number	Noise Figure 3.060 GHz LO = 1.0 mW RI = 100 Ohms MAX (dB)	VSWR 3.060 GHz LO = 1.0 mW RI = 100 Ohms MAX (Ratio)	IF Impedance 3.060 GHz LO = 1.0 mW RI = 100 Ohms MIN/MAX (Ohms)	Conversion Loss 3.060 GHz LO = 1.0 mW RI = 100 Ohms MAX (dB)	Case Style
1N21C	8.5	-	325 - 465	-	PS100
1N21D	7.5	-	325 - 465	-	PS100
1N21E	7.0	1.5	350 - 450	-	PS100
1N21WE	7.0	1.5	350 - 450	-	PS101
1N21F	6.0	1.3	350 - 450	-	PS101
1N21G	5.5	1.3	350 - 450	5.0	PS100
1N21WG	5.5	1.3	350 - 450	5.0	PS100
1N416C	8.5	1.5	335 - 465	-	PS101
1N416D	7.5	1.3	335 - 465	-	PS101
1N416E	7.0	1.3	335 - 465	7.0	PS101
1N416F	6.5	1.3	335 - 465	6.5	PS101
1N416G	6.0	1.3	335 - 465	6.0	PS101

Part Number	Noise Figure 9.375 GHz LO = 1.0 mW RI = 100 Ohms MAX (dB)	VSWR 9.375 GHz LO = 1.0 mW RI = 100 Ohms MAX (Ratio)	IF Impedance 9.375 GHz LO = 1.0 mW RI = 100 Ohms MIN/MAX (Ohms)	Conversion Loss 9.375 GHz LO = 1.0 mW RI = 100 Ohms MAX (dB)	Case Style
1N23	12.0	-	200 - 600	-	PS100
1N23A	11.0	-	200 - 600	-	PS100
1N23B	10.0	1.5	335 - 465	-	PS100
1N23C	9.0	1.5	335 - 465	-	PS100
1N23D	8.5	1.3	335 - 465	-	PS100
1N23E	7.5	1.3	335 - 465	7.0	PS100
1N23WE	7.5	1.3	335 - 465	7.0	PS101
1N23F	7.0	1.3	335 - 465	6.5	PS100
1N23G	6.5	1.3	335 - 465	6.0	PS101
1N23WG	6.5	1.3	335 - 465	6.0	PS101
1N23H	6.0	1.3	335 - 465	5.5	PS100
1N415C	9.0	1.5	335 - 465	-	PS101
1N415D	8.5	1.3	335 - 465	-	PS101
1N415E	7.5	1.3	335 - 465	7.0	PS101
1N415F	7.0	1.3	335 - 465	6.5	PS101
1N415G	6.5	1.3	335 - 465	6.0	PS101
1N415H	6.0	1.3	335 - 465	5.5	PS101

NOTES:

For matched Fwd pair use suffix M after P/N

For reverse device use suffix R

For matched Fwd and Rev use suffix MR

Operating Temperature:

-55°C to 150°C

Storage Temperature:

-65°C to 200°C

X BAND POINT CONTACT MIXER DIODES

Point Contact Diodes: 1N Series

Description

The Massachusetts Bay Technologies 1N series of Point Contact Mixer diodes is designed for applications through X-Band. These diodes employ epitaxial silicon optimized for low noise figure and wide bandwidth and are specifically designed for use in stripline, microstrip and coaxial environments. Each device in this series is in an axial lead glass package.

Applications

The 1N series of Point Contact Mixers is suitable for use in waveguide, coaxial and stripline applications.

Packaging

- Axial Lead Glass

Electrical Specifications

Typical Performance

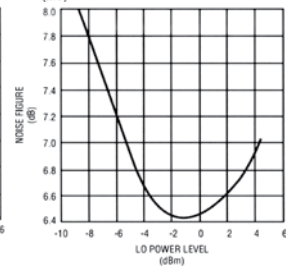
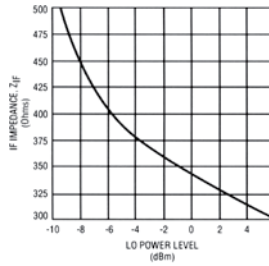
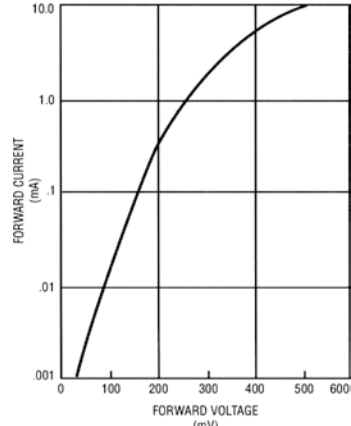

Part Number	Noise Figure 3.060 GHz LO = 1.0 mW RI = 100 Ohms MAX (dB)	VSWR 3.060 GHz LO = 1.0 mW RI = 100 Ohms MAX (Ratio)	IF Impedance 3.060 GHz LO = 1.0 mW RI = 100 Ohms MIN/MAX (Ohms)	Conversion Loss 3.060 GHz LO = 1.0 mW RI = 100 Ohms MAX (dB)	Case Style
1N831	8.5	—	300 - 500	—	PS-60
1N831A	7.5	—	300 - 500	—	PS-60
1N831B	6.5	—	300 - 500	—	PS-60
1N831C	6.0	—	300 - 500	—	PS-60

Part Number	Noise Figure 9.375 GHz LO = 1.0 mW RI = 100 Ohms MAX (dB)	VSWR 9.375 GHz LO = 1.0 mW RI = 100 Ohms MAX (Ratio)	IF Impedance 9.375 GHz LO = 1.0 mW RI = 100 Ohms MIN/MAX (Ohms)	Conversion Loss 9.375 GHz LO = 1.0 mW RI = 100 Ohms MAX (dB)	Case Style
1N832	9.5	—	250 - 550	—	PS-60
1N832A	7.5	—	250 - 550	—	PS-60
1N832B	7.0	—	250 - 550	—	PS-60
1N832C	6.5	—	250 - 550	—	PS-60

Operating Temperature:

-55°C to 150°C

Storage Temperature:

-65°C to 200°C

Ka BAND POINT CONTACT DETECTOR DIODES

Point Contact Diodes: 1N Series

Description

The Massachusetts Bay Technologies 1N series of Point Contact Detector diodes is designed for applications through Ka-band. These diodes employ epitaxial silicon optimized for high tangential signal sensitivity (TSS), and are suitable for use in waveguide, coaxial and stripline applications. Being point contact diodes, they are efficient detectors not requiring the use of bias. Devices in this series are available in glass or cartridge packaging.

Packaging

- Glass or Cartridge

Applications

The 1N series of Point Contact Detectors is suitable for use in waveguide, coaxial and stripline applications.

Typical Performance

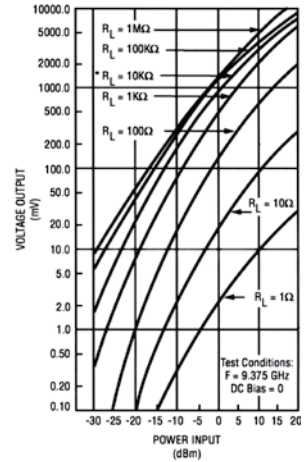
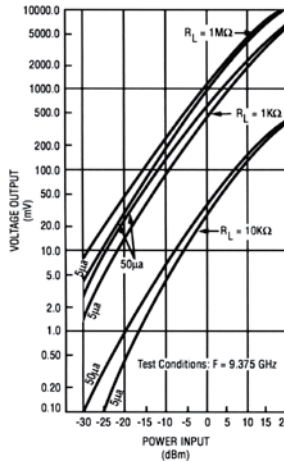

Electrical Specifications

Part Number	Rectification Efficiency MIN	Tangential Signal Sensitivity (-dBm)	Video Resistance MAX (K Ohms)	Operating Frequency (MHz)	Case Style
1N830	65%	-	-	100	PS-60
1N830A	65% @ 5 vdc	-	-	100	PS-60
1N32	-	49	22	3000	PS-100
1N32A	-	47	17	3000	PS-100
1N833	-	40	18	9375	PS-60
1N833A	-	45	18	9375	PS-60
1N1611	-	51	3.1	9000	PS-100
1N1611A	-	53	3.1	9000	PS-100
1N1611B	-	53	3.1	9000	PS-100
1N3778	-	50	10	9375	PS-101

Operating Temperature:

-55°C to 150°C

Storage Temperature:

-65°C to 200°C

MIS CHIP CAPACITORS

The Massachusetts Bay Technologies MCC1100, MCD2100 series MIS Chip Capacitors are available in a wide range of sizes and capacitance values. They feature High Reliability Silicon Nitride/Oxide Dielectric, Low Loss, High Q and wide temperature operation.

Applications: DC Blocks • Filters • Oscillators • Multipliers
Packaging Options: Chip, Vial Pak, Wafer Form

How To Order: Go to Table 1 (MCC1100 Series >100 Volt Working Voltage).
Select capacitance range required.
Choose Chip size for circuit.
If the chip size on table 1 is too large for your application, please go to Table 2 (MCD2100 Series >50 Volt Working Voltage). Select capacitance range required.
Choose Chip size for circuit.

Specify Part Number examples below:

EXAMPLE: MCC1100-100K=100VB, 100pF, $\pm 10\%$ Tolerance

EXAMPLE: MCD2100-10G=50 VB, 10pF, $\pm 2\%$ Tolerance

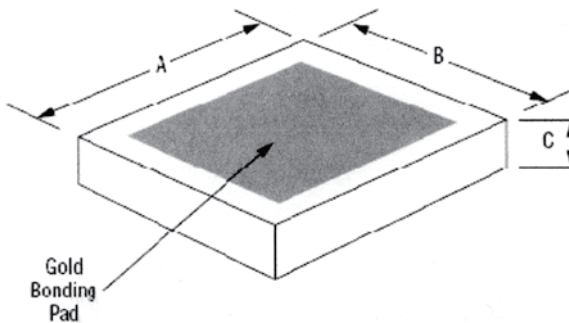

MCC1100 SERIES CHIP CAPACITORS

Working Voltage >100

TABLE 1

PART NUMBER	CAPACITANCE VALUE (pF)	CHIP SIZE ±.002"
MCC1100	.1pF-1.9pF	10x10
MCC1100	2.0pF-9.9pF	15x15
MCC1100	10.0pF-29pF	20x20
MCC1100	30.0pF-49pF	30x30
MCC1100	50.0pF-99pF	40x40
MCC1100	100pF-199pF	50x50
MCC1100	200pF-399pF	70x70

MCD2100 Series Chip Capacitors

Working Voltage >50

TABLE 2

PART NUMBER	CAPACITANCE VALUE (pF)	CHIP SIZE ±.002"
MCD2100	2.0pF-10.0pF	10x10
MCD2100	10.0pF-29pF	15x15
MCD2100	30.0pF-49pF	20x20
MCD2100	50.0pF-49pF	30x30
MCD2100	100pF-199pF	40x40
MCD2100	200pF-399pF	50x50
MCD2100	400pF-600pF	70x70

Maximum Ratings:

Storage Temperature	-65 to 200°C
Operating Temperature	-55 to 150°C
Temperature Coefficient	190ppm/°CMax 40ppm/ °C Typical
Voltage Breakdown	Varies by part number

Tolerance ±Table

D=.5%	K=10%
F=1%	M=20%
G=2%	
J=5%	

Standard Tolerance is ±10%(K)

MIC MOUNTING CAPACITORS

Description

The Massachusetts Bay Technologies mounting capacitors are designed for transient protection for MIC's and FET's. A wide range of sizes and capacitance values are available as standard products. There is virtually no limit to size or capacitance value available.

Applications

Mounting Capacitors are used in applications for hybrid microelectronics at microwave frequencies.

Packaging

Chip, Vial, Wafer Form.

Chip Outline

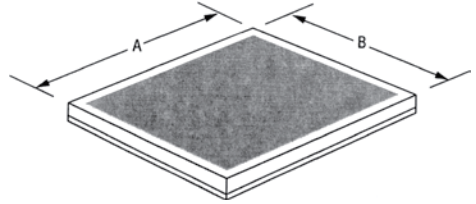

STANDARD CAPACITANCE AND CHIP SIZES

PART NUMBER	CAPACITANCE RANGE	CHIP SIZE		PAD SIZE	
		A	B	A	B
MBT1	100 pF - 500 pF	.070"	.070"	.065"	.065"
MBT2	150 pF - 750 pF	.085"	.085"	.080"	.080"
MBT3	200 pF - 1000 pF	.100"	.100"	.095"	.095"
MBT4	250 pF - 1250 pF	.110"	.110"	.100"	.100"
MBT5	300 pF - 1500 pF	.110"	.140"	.100"	.130"
MBT6	300 pF - 1500 pF	.120"	.140"	.110"	.130"

Maximum Ratings

VB=>100 volts

Operating Temperature

-55°C to +150°C

Storage Temperature

-65°C to +200°C

Voltage Breakdown

Varies According To Requirement

Standard Thickness

.012"±.002". Special thickness available on request

Specify Part Number examples below:

EXAMPLE: MBT1-100K=100pF, ±10% Tolerance

BINARY CHIP CAPACITORS

MBA, MBB Series

Description

The Massachusetts Bay Technologies MBA, MBB Series binary chip capacitor series feature a high reliability Silicon Nitride-Oxide dielectric for long term reliability and stability.

Applications

Binary Chip Capacitors are used in applications requiring a trimming capability and breadboarding.

Packaging

Chip, Vial Pack, Wafer Form.

Chip Outline 1

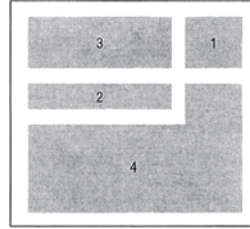

Chip Outline 2

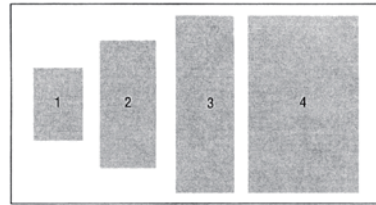

Electrical Characteristics

.020 x .020	MBA-3R75K	MBA-7R5K	MBA-15RK	MBA-22R5K
PAD1	0.25 pF	0.5 pF	1.0 pF	1.5pF
PAD 2	0.5 pF	1.0 pF	2.0 pF	3.0 pF
PAD3	1.0 pF	2.0 pF	4.0 pF	6.0 pF
PAD 4	2.0pF	4.0 pF	8.0 pF	12.0pF
TOTAL	3.75 pF	7.5 pF	15 pF	22.5 pF

.020 x .040	MBB-3R75K	MBB-7R5K	MBB-15RK	MBB-22R5K
PAD1	0.25 pF	0.5 pF	1.0 pF	1.5pF
PAD 2	0.5 pF	1.0 pF	2.0 pF	3.0 pF
PAD3	1.0 pF	2.0 pF	4.0 pF	6.0 pF
PAD 4	2.0pF	4.0 pF	8.0 pF	12.0pF
TOTAL	3.75 pF	7.5 pF	15 pF	22.5 pF

Notes:

Temperature Coefficient: < 100 PPM/ °C (20 PPM TYP.)

Dielectric; Silicon Dioxide/Silicon Nitride

Equivalent Series Res.: < .05 Ohms @>18Ghz

Insulation Resistance. 10¹² Ohms TYP.

Thermal Conductivity: 1.2 °C/cm/W

Capacitance Range: 0.1 pF to 600 pF

Maximum Ratings

Operating Temperature -55°C to +150°C

Storage Temperature -65°C to +200°C

Temperature Coefficient 190 ppm/°C Max

400 ppm/°C Typical

Voltage Breakdown 100 Volts

SPIRAL INDUCTORS

Description

The Massachusetts Bay Technologies MSI series of Spiral Inductor chips are formed by plating and photo/etch techniques on quartz substrates. These devices are designed to meet hybrid microwave circuit requirements through Ku band. They eliminate the need for hand forming and "staking" coil in hybrid circuits.

Applications

Spiral inductors are used for bias injection into oscillators, amplifiers and microwave switches (bias tees).

They can also be used for bias tuning Varactor diodes, PIN diodes, transistors, and monolithic circuits.

Packaging

Chip.

Chip Outline PS-133

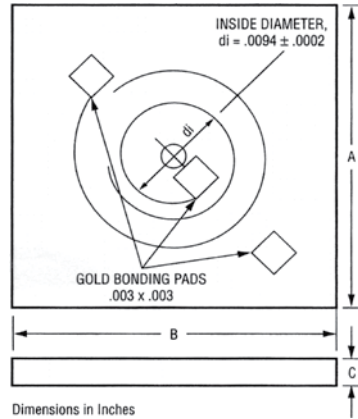

EQUIVALENT CIRCUIT

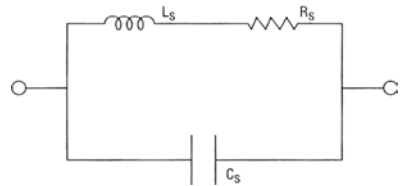

Dimensions: Inches

MODEL	DM "A" MAX	DM "B" MAX	DM "C" MAX
MSI201	.030	.030	.020
MSI202	.030	.030	.020
MSI203	.040	.040	.020
MSI204	.040	.040	.020
MSI205	.040	.040	.020

MODEL	DIM "A" MAX	DIM "B" MAX	DIM "C" MAX
MSI206	.045	.045	.020
MSI207	.055	.055	.020
MSI208	.065	.065	.020
MSI209	.075	.075	.020
MSI210	.085	.085	.020

Electrical Characteristics

PART NUMBER	# OF TURNS	INDUCTANCE		R _S DC	R _S 1GHz	Q @ F _t MIN/MAX	TEST FREQUENCY, F _t (GHz)	RESONANT FREQUENCY, F _r (GHz)
		L _S (nH) MIN/TYP/MAX	R _S					
MSI201	1.5	1.0/1.5/2.0	8.5	1.0	60/75	1.5	4.0	
MSI202	2.5	2.0/2.3/2.6	1.0	1.4	50/60	1.5	3.6	
MSI203	3.5	3.6/4.2/5.0	1.15	2.0	40/45	1.5	3.2	
MSI204	4.5	5.0/7.5/9.0	1.75	3.5	37/43	1.5	2.3	
MSI205	5.5	8.0/10/12.0	1.85	3.75	33/38	1.0	2.05	
MSI206	7.5	15/20/25	2.4	4.25	27/33	0.5	1.85	
MSI207	9.5	32/40/48	4.0	7.0	23/27	0.5	1.4	
MSI208	12.5	80/90/100	9.5	22	18/24	0.5	0.975	
MSI209	15.5	150/200/250	16.5	36	14/18	0.5	0.460	
MSI210	18.5	250/300/350	20	42	10/15	0.5	0.250	

Notes:

L_S, R_S and F_t data measured using an HP 8510 network analyzer.

Inductor cross section is approximately 16 microns wide and 5 microns thick.

Maximum current rating: 250 mA.

Other values available upon request.

Massachusetts Bay Technologies, Inc. • 378 Page Street, Stoughton, MA 02072

THIN FILM RESISTOR CHIPS

Passive Components

Description

The Massachusetts Bay Technologies Thin Film Resistor Chip series are low noise and excellent TCR. They are available in a large selection of outline types, resistance values and tolerances.

Applications

Thin Film Resistors are used in hybrid assembly applications.

Packaging

Chip.

Electrical Specifications

	Parameter	Test Condition	
TCR	-55°C to +125°C	±150 ppm/°C (Standard Value)	MAX
TCR	-55°C to +125°C	±100ppm/°C	MAX
TCR	-55°C to +125°C	±50 ppm/°C	MAX
TCR	-55°C to +125°C	±10 ppm/°C (Special Request, NiCR only)	MAX
Operating Voltage	-55°C to +125°C	100 Vdc	MAX
Power Rating (^R Total)	@70°C (derate linearly to 0 @150°C)	250 mW	MAX
Single Series	@70°C (derate linearly to 0 @150°C)	250 mW	MAX
Center-Tap	@70°C (derate linearly to 0 @150°C)	250 mW	MAX
Multi-Tap	@70°C (derate linearly to 0 @150°C)	250 mW	MAX
Thermal Shock	Method 107 MIL-STD-202 F	±0.5%@ΔR	MAX
High Temperature Exposure	100 Hrs @ 150°C Ambient	±0.25%@ΔR	MAX
Moisture Resistance	Method 106 MIL-STD-202F	±0.5%@ΔR	MAX
Life	Method 108 MIL-STD-202 F (125°C/1000 hr)	±0.5%@ΔR	MAX
Noise	Method 308 MIL-STD-202 F	-20 dB	MAX
Insulation Resistance	@25°C	1 x 10 ¹² Ohms	MIN

NOTES:

Resistor pattern may vary from one value to another.

Specifications are subject to change without notice or obligation.

Mechanical Specifications for Silicon Body Only

Substrate:	Silicon 10 ±2 mils thick
Isolation Layer:	SiO ₂ 10,000Å thick, min
Backing:	Lapped surface only (no metal)
Solderable:	Gold plated backside (optional)
Metalization:	Gold 10,000Å thick, min, front contacts
Gold Bonding Pads:	Front contact (> .0035" Sq.)

RESISTOR ORDERING SYSTEM

EXAMPLE

1 2 3 4 5 6 7 8
MRT-2200-SR2-K-F-G-2-N

1) is the three letter device type designation

MRT	Single Value through Chip Resistor (Resistance top to bottom)
MRP	Single Value Pad to Pad Chip Resistor (Resistance Top pad to Top pad)
MRD	Dual Value Center Tap Ratio Chip Resistor. (Res. #1 = Prime Value / Res. #2 = Ratio Value)
MRM	MultiTap Chip Resistor.
XXX	as needed.

2) is the resistance value in ohms

2R2K	2,200 Ohms
200R	200 Ohms
20R	20 Ohms
2R2M	2,200,000 Ohms
20R2K	20,200 Ohms
200RK	200,000 Ohms

please see pp XX-XX for details. R is decimal point. 2R=2 ohms.

3) is the chip substrate material and chip outline dimensions (case style) R1 - R8

		case		
S	Silicon Body	R1	.038"X.038"	20 Tap Multi-tap
C	Ceramic	R2	.030"X.030"	Dual Value
B	Berillium Oxide	R3	.020"X.020"	Single Value
Q	Quartz	R4	.020"X.060"	Six Value Ladder
N	Aluminum Nitride	R5	.030"X.030"	12 Tap Multi Tap
SP	Special Material	R6	.030"X.030"	Single Low Value
		R7	.020"X.040"	Single Value
		R8	.020"X.020"	Single Low

please consult factory for special substrate materials (SP)

*R8 Outline for resistances <250 Ohms. C=99.6 Alumina.

4) is the resistor value total % ±tolerance

5) is the 2nd resistor value total % ±tolerance (if applicable)

A) On Dual Value Ratio Resistors, (MRD), this is the res. ratio of the 2nd resistor (Ratio Res.) To value of the 1st resistor (Prime Res.)

B) On Multi Tap Resistors (MRM). This is the tolerance of each of the small value Resistor Taps. The large value Resistor Taps are called out on (4).

A	±.05%	G	±2%
B	±.10%	J	±5%
C	±.25%	K	±10%
D	±.50%	M	±20%
F	±1%	NA	Not applicable

6) backing

G	Solderable Gold attachment
GS	Gold Silicon eutectic attachment
B	Bare back epoxy attach

7) the temperature coefficient (TCR) of the resistor, in PPM

0	±150 PPM Standard
1	±100 PPM
2	±50 PPM
3	±10 PPM

8) resistor material

T	Tantalum Nitride TaN (Self-Passivating)
N	NiChrome NiCr

THIN FILM ATTENUATOR PADS

Passive Components: MAP 10000 Series

Description

The Massachusetts Bay Technologies Fixed Attenuator chips are fabricated using our state of the art thin film process and advanced photolithography technology. The use of special substrate material and advanced thickness control combine to make the power handling and temperature stability of these devices outstanding. The special device design and advanced laser trim account for the attenuator flatness over frequency (± 1 dB < 26 GHz) and attenuation single value tolerance (± 1 dB) from device to device.

All devices are available as chips with either a bare back version for epoxy die attach or a metallized back version for solder die attach.

Gold contact pads on the input and output make assembly using standard TC bonding equipment fast and reliable.

Massachusetts Bay Technologies will also supply these devices assembled in a four leaded package for surface mount applications. We also offer custom assembly in any package configuration required.

Packaging

- Chip

Attenuator Pads

Model	Attn. (dB)	IL (dB)	RL (dB)
MAP10010	1.0	± 0.30	>18
MAP10020	2.0	± 0.30	>18
MAP10030	3.0	± 0.30	>18
MAP10040	4.0	± 0.30	>18
MAP10050	5.0	± 0.30	>18
MAP10080	8.0	± 0.30	>18
MAP10100	10.0	± 0.30	>18
MAP10150	15.0	± 0.40	>18
MAP10200	20.0	± 0.50	>18
MAP10250	25.0	± 0.60	>18
MAP10300	30.0	± 1.0	>18

Notes: Resistor pattern may vary from one value to another. Specifications are subject to change without notice or obligation.

PACKAGE STYLES

CHIP STYLES

R1

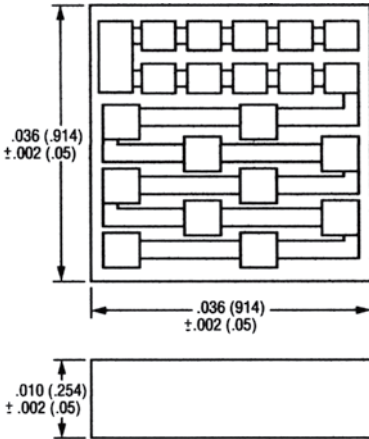

Notes:

The top gold bonding pads are .004" square typ. (.0035 min. and 10,000 Å thick min.)

There is a min. separation between the edge of the chip and any of the top bonding pads of .001"

R3

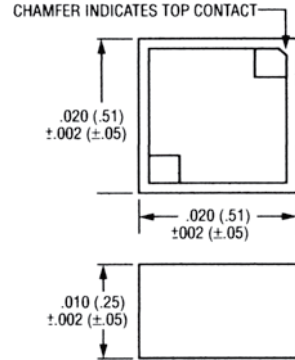

Notes:

The top gold bonding pads are .004" square typ. (.0035 min. and 10,000 Å thick min.)

There is a min. separation between the edge of the chip and any of the top bonding pads of .001"

Available as thru-chip.

R2

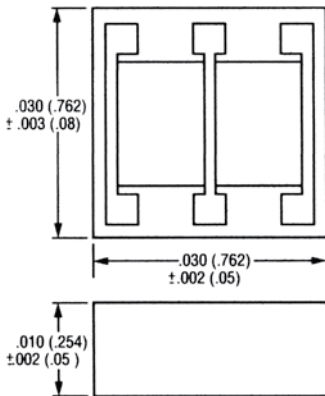

Notes:

The top gold bonding pads are .004" square typ. (.0035 min. and 10,000 Å thick min.)

There is a min. separation between the edge of the chip and any of the top bonding pads of .001"

R8

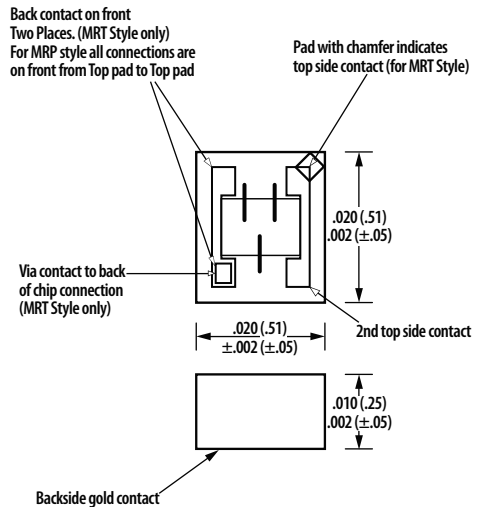

Notes:

The top gold bonding pads are .004" square typ. (.0035 min. and 10,000 Å thick min.)

There is a min. separation between the edge of the chip and any of the top bonding pads of .001"

Available as thru-chip.

PS-01

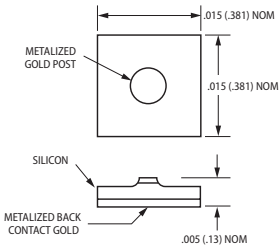

Notes:
Top contact & chip size depends on diode parameters.

Top & bottom contacts gold.

Consult factory.

PS-03

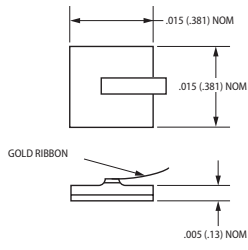

Notes:
Top contact & chip size depends on diode parameters.

Top & bottom contacts gold.

Consult factory.

PS-04

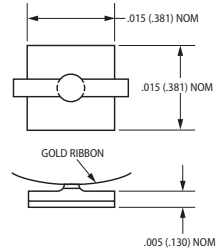

Notes:
Top contact & chip size depends on diode parameters.

Top & bottom contacts gold.

Consult factory.

PS-05

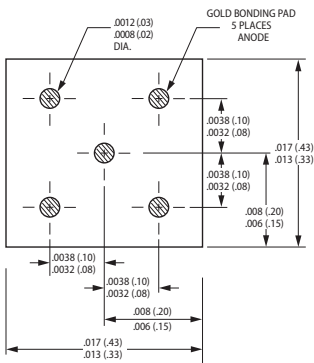

PS-06

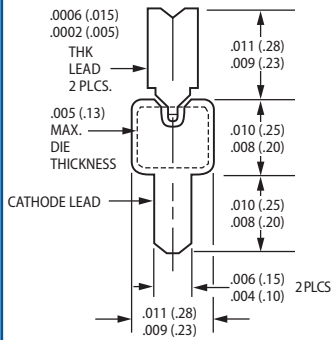

PS-16

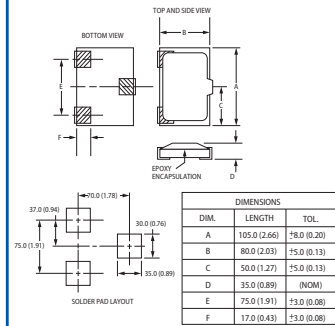

PS-07

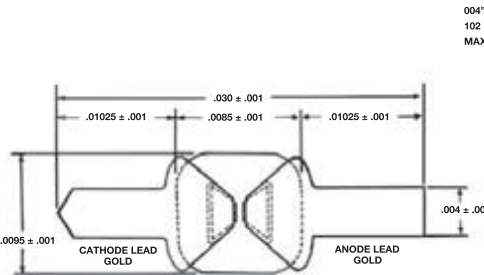

004"
102
MAX.

PS-14

CERAMIC VERSION

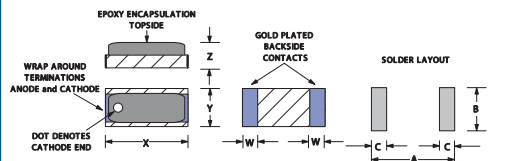

PKG STYLE	DIMENSIONS				SOLDER LAYOUT (TYP.)			PACKAGE CP AND LP
	W DIM.	X DIM.	Y DIM.	Z DIM.	A	B	C	
PS14-d	.010 (.254)	.040 (1.01)	.020 (.508)	.040 (1.02)	.050 (1.27)	.030 (.762)	.015 (.381)	.05 PF, 0.4 NH
PS14-7	.010 (.254)	.060 (1.52)	.020 (.508)	.040 (1.02)	.070 (1.78)	.030 (.762)	.015 (.381)	.06 PF, 0.4 NH
PS14-1	.012 (.304)	.060 (1.52)	.040 (1.01)	.040 (1.02)	.070 (1.78)	.050 (1.27)	.020 (.508)	.06 PF, 0.4 NH
PS14-2	.012 (.304)	.070 (1.91)	.050 (1.27)	.040 (1.02)	.080 (2.03)	.060 (1.53)	.020 (.508)	.07 PF, 0.4 NH
PS14-3	.012 (.304)	.100 (2.54)	.050 (1.27)	.040 (1.02)	.110 (2.79)	.060 (1.53)	.020 (.508)	.08 PF, 0.5 NH
PS14-4	.012 (.304)	.120 (3.05)	.060 (1.52)	.050 (1.27)	.130 (3.30)	.070 (1.78)	.020 (.508)	.09 PF, 0.6 NH
PS14-5	.020 (.508)	.160 (4.07)	.080 (2.03)	.060 (1.52)	.170 (4.32)	.090 (2.27)	.030 (.762)	.11 PF, 0.8 NH
TOL. ±	.002 (.051)	.003 (.076)	.003 (.076)	MAX.	NOM.	NOM.	NOM.	NOM.

Dimensions shown .xxx are in inches, (x.xxx) are in millimeters

PS-15

ALUMINUM NITRIDE VERSION

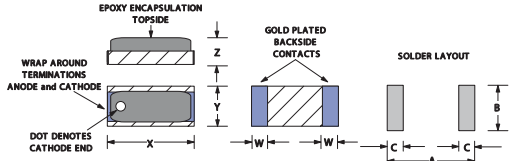

PKG STYLE	DIMENSIONS			SOLDER LAYOUT (TYP.)			PACKAGE CP AND LP
	W DIA.	X DIA.	Z DIA.	A	B	C	
PS15-6	.010 (.254)	.040 (1.01)	.020 (.508)	.050 (1.27)	.030 (.762)	.015 (.381)	.05 pf, 0.4 nh
PS15-7	.010 (.254)	.060 (1.52)	.040 (1.01)	.070 (1.78)	.030 (.762)	.015 (.381)	.06 pf, 0.4 nh
PS15-1	.012 (.304)	.060 (1.52)	.040 (1.01)	.070 (1.78)	.050 (1.27)	.020 (.508)	.06 pf, 0.4 nh
PS15-2	.012 (.304)	.070 (1.91)	.050 (1.27)	.040 (1.02)	.080 (2.03)	.060 (1.53)	.07 pf, 0.4 nh
PS15-3	.012 (.304)	.100 (2.54)	.050 (1.27)	.040 (1.02)	.110 (2.79)	.060 (1.53)	.08 pf, 0.5 nh
PS15-4	.012 (.304)	.120 (3.05)	.060 (1.52)	.050 (1.27)	.130 (3.30)	.070 (1.78)	.09 pf, 0.6 nh
PS15-5	.020 (.508)	.160 (4.07)	.080 (2.03)	.060 (1.52)	.170 (4.32)	.090 (2.27)	.11 pf, 0.8 nh
TOL. ±	.002 (.051)	.003 (.076)	.003 (.076)	MAX.	NOM.	NOM.	NOM.

Dimensions shown .xxx are in inches, (.xxx) are in millimeters

PS-18

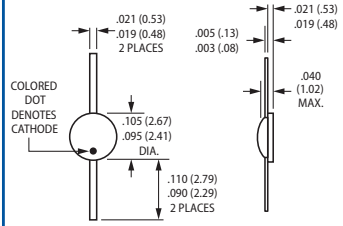

PS-19

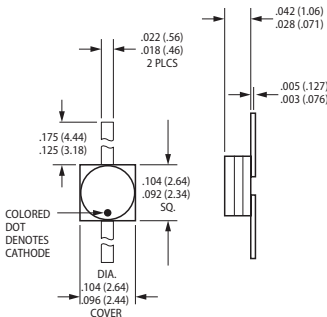

PS-23

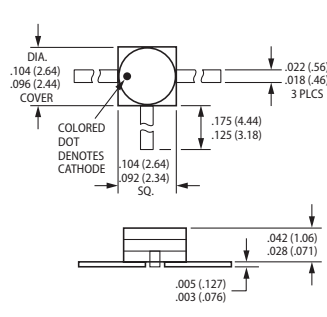

PS-24

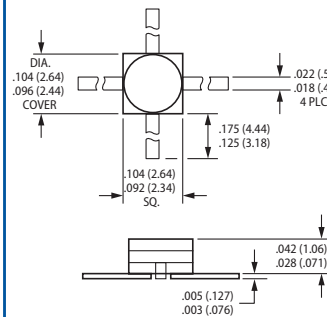

PS-25

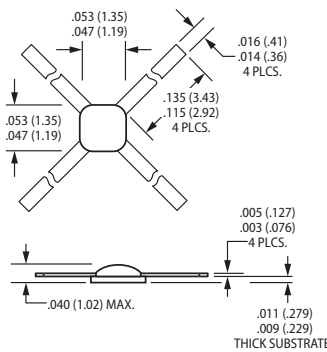

PS-30

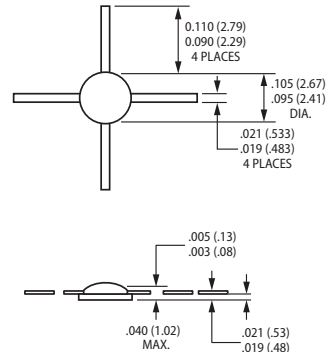

PS-31

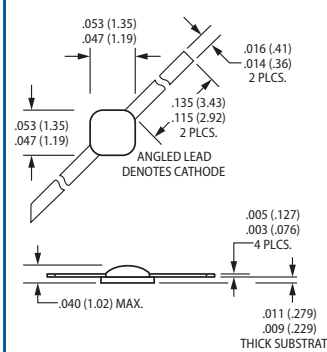

PS-33

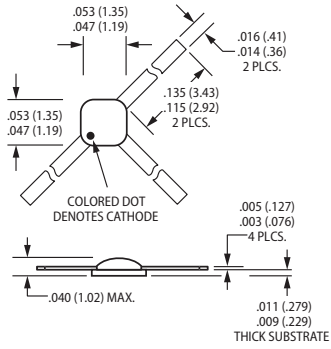

PS-36

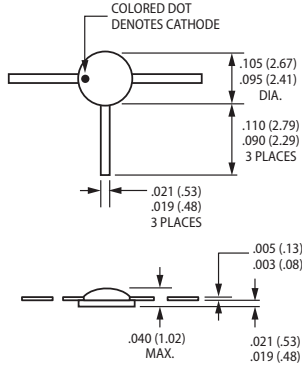

PS-39

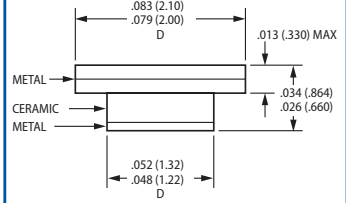

PS-40

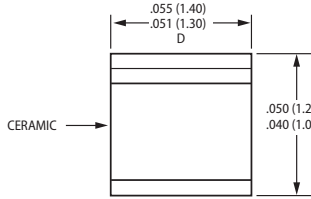

PS-41

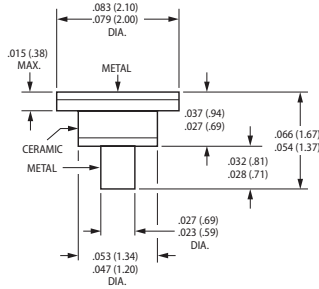

PS-43

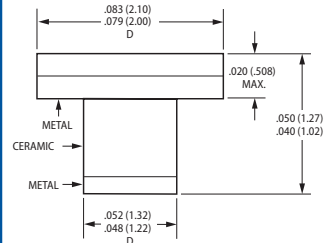

PS-45

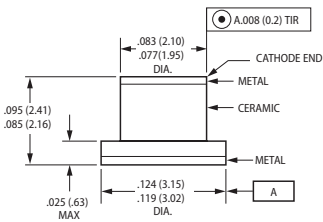

PS-46

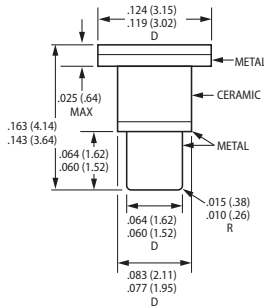

Note:
 .062 and .121 dia. shall be concentric
 within .008 tir.

PS-47

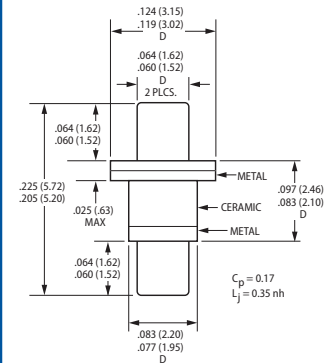

PS-48

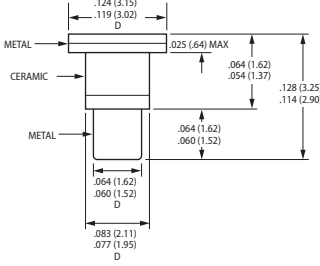

PS-49

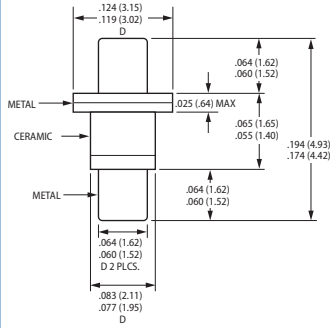

PS-50

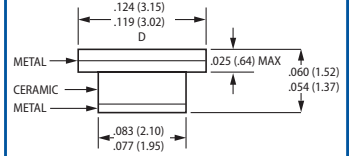

PS-51

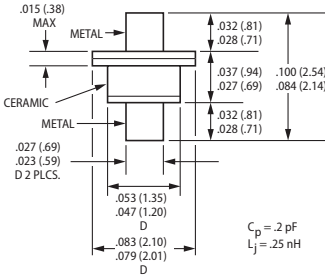

PS-52

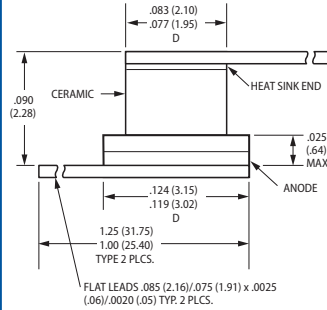

PS-55

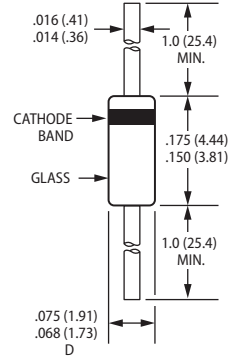

PS-58

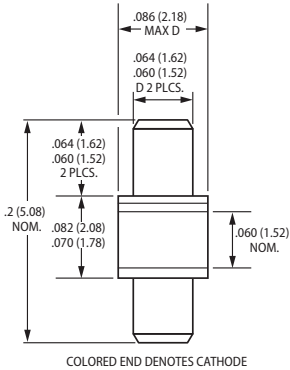

PS-60

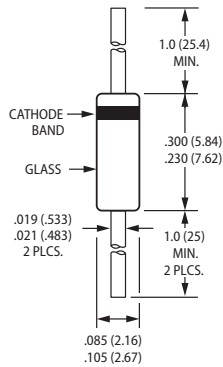

PS-70

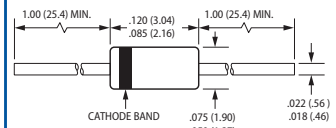

PS-90

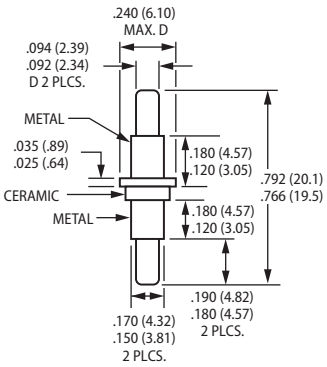

PS-95

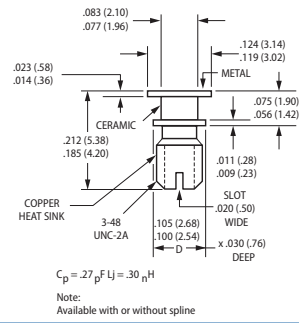

PS-100

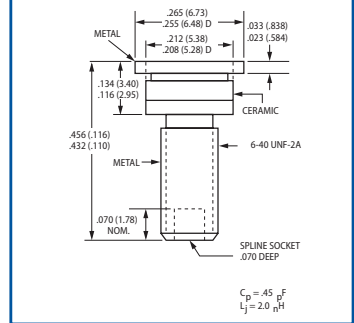

PS-118

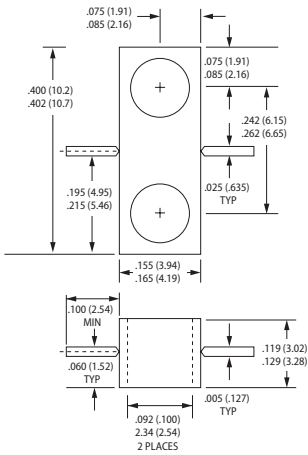

PS-122

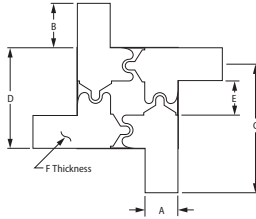

DIM.	INCHES		MILLIMETERS	
	MIN.	MAX.	MIN.	MAX.
A	.0045	.0065	0.114	0.165
B	.007	.009	0.178	0.229
C	.017	.019	0.432	0.438
D	.017	.019	0.432	0.483
E	.006	.008	0.152	0.203
F	.0003	.0005	0.008	0.013

PS-126

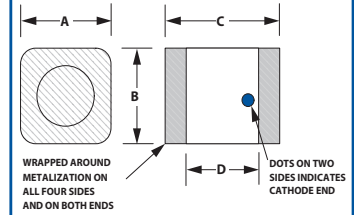

PS-S0T-23

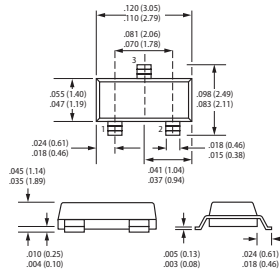

Different Versions Available Upon Request

PS-99

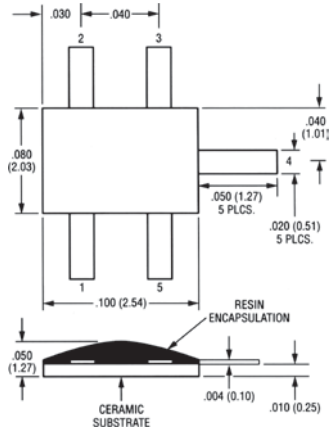

PS-100

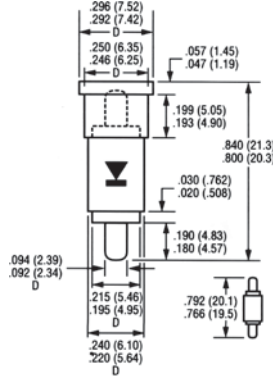

Note:
Base non-removable, enclosing prong with dimensions same as other prong.

PS-101

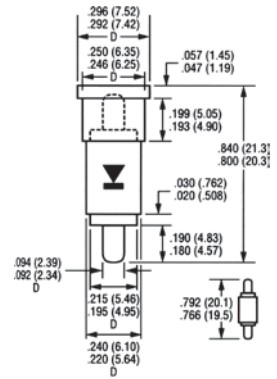

Note:
Base removable, enclosing prong with dimensions same as other prong.

PS-102

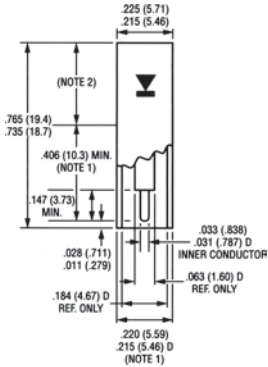

Notes:
1. Outside D. 0.220/.215 applies only to 0.406 length as shown.
2. Marking to be confined to this region.

PS-103

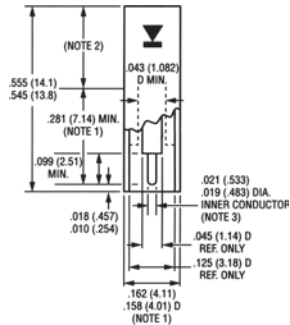

Notes:
1. Outside D. .160 applies only to .281 length as shown.
2. Marking to be confined to this region.
3. Space for matching transformer (when used).

TUNING VARACTORS APPLICATION NOTE

Introduction

Tuning varactors are voltage variable capacitors designed to provide electronic tuning of oscillators and filters.

The two semiconductor materials used are silicon and gallium arsenide. Silicon typically offers lower manufacturing cost, while gallium arsenide diodes provide higher Q and may be used at higher microwave frequencies.

Within the general family of tuning varactors, there are several major categories, each designed for particular consideration of application and cost.

Circuit tuning requirements will define the appropriate device capacitance versus voltage curve and specific material doping gradients. Explanations of the various material gradients are as follows:

Abrupt Junction: As processing techniques improved and new ones developed, it became possible to obtain uniformly doped profiles, which resulted in inverse square root dependence. This type is called Abrupt Junction and is presently most commonly used.

Hyperabrupt: Many applications require a linear or nearly linear variation of frequency with applied control voltage. The inverse square root dependence of the Abrupt Junction design provides an inherent inverse fourth root frequency dependence, most decidedly non-linear. To provide linearity, it is necessary to add a linearizer or buffer logic stage to convert the applied control signal to a non-linear diode bias voltage, compensating for the C-V curve of the diode. This results in complexity, cost and inherently slower modulation capability. To remedy this problem, newer forms of C-V curves were developed. They were all called hyperabrupt diodes and were designed to produce a C-V variation that had, at least over a sometimes

small portion of the curve, an inverse square law. This provides a narrow band linear frequency variation.

The first hyperabrupts made used ion-implantation to create the special non-uniform doping required. This technique results in excellent uniformity and reliability, and inherent low cost, together with large capacitance swings. Unfortunately, the laws of physics result in substantial reduction in Q, as compared to abrupt junction design, with the result being that hyperabrupt diodes can be used only at lower microwave frequencies, up to a few GHz at best.

Linear Tuning: Massachusetts Bay Technologies has developed a state of the art Tuning Varactor using new techniques for producing computer controlled variable epitaxial layer doping, (the epitaxial layer is the "active" part of a tuning varactor). This new diode has > square law C-V variation over its entire tuning range, providing direct linear tuning over more than one octave. In addition, Q is substantially higher than in ion implantation hyperabrupts.

Figures 1, 2, and 3 (on the next page) show C-V curves, Q and frequency-voltage curves for abrupt, implanted and linear diodes, in each case for a $C_{-4} = 1.0$ pF diode.

There are many design variations within each class, and the curves are indicative, rather than specific.

TUNING VARACTORS APPLICATION NOTE (Cont.)

Figure 1. Tuning Varactor C-V Curves

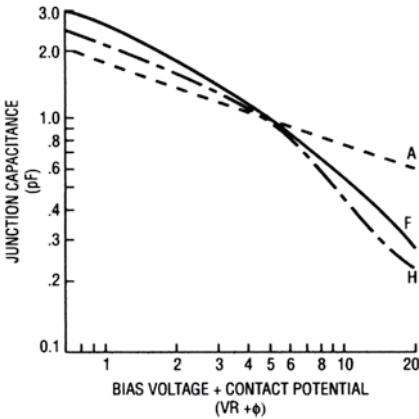

$$A = \text{Abrupt Junction } C_j(V_R) = \frac{C_{j0}}{(1+V_R)^\gamma}$$

$$F = \text{Frequency Linear } C_j(V_R) = \frac{C_{j0}}{(1+V_R)^2}$$

$$H = \text{Hyperabrupt Junction } C_j(V_R) = \frac{C_{j0}}{(1+V_R)^\gamma}$$

$\gamma = 0.5$ for Abrupt Junction, $\gamma > 0.5$ for Hyperabrupt Junction
 $\phi = \text{Contact Potential } (\phi = 0.7V \text{ for } 51, \phi = 1.1V \text{ for } \text{GsAs})$

Figure 2. Tuning Varactor Q Variation

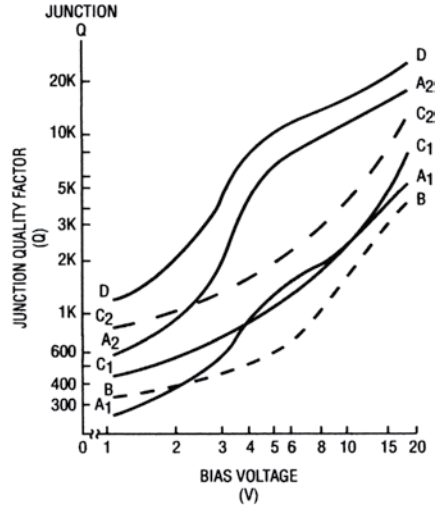

A₁ = Abrupt Junction Ratio -10

A₂ = Abrupt Junction Ratio -5

B = Ion Implanted Hyperabrupt Ratio -5

C₁ = Controlled Epi Linear, Ratio -20

C₂ = Controlled Epi Linear, Ratio -8

D = GaAs Abrupt, Ratio -6

Ratio = C₂ MAX / C₂ MIN

Figure 3. Tuning Varactor Frequency-Voltage Curves

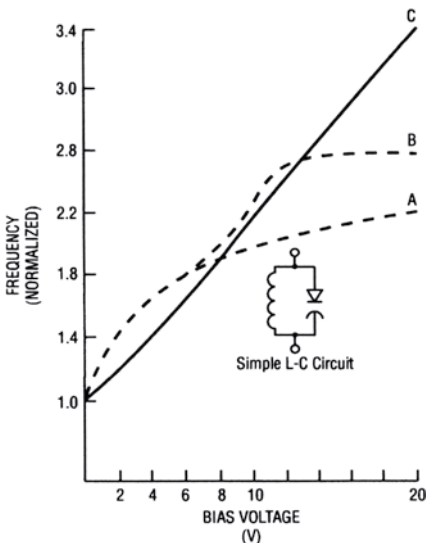

A = Abrupt Junction

B = Ion Implanted Hyperabrupt

C = Controlled Epi Linear

TUNING VARACTORS APPLICATION NOTE (Cont.)

Mathematical Model

A varactor diode is a P-N junction diode that changes its capacitance and the series resistance as the bias applied to the diode is varied. The property of capacitance change is utilized to achieve a change in the frequency and/or the phase of an electrical circuit. A simple mathematical model of a packaged varactor diode is shown below.

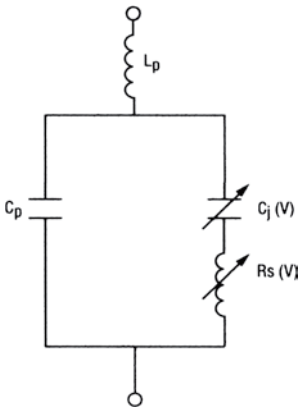

In the above figure, $C_j(V)$ is the variable junction capacitance of the diode die and $R_s(V)$ is the variable series resistance of the diode die. C_p is the fixed parasitic capacitance arising from the installation of the die in a package. Contributors to the parasitic capacitance are the package material, geometry and the bonding wires or ribbons. These factors also contribute to the parasitic inductance L_p . The contribution to the series resistance from the packaging is very small and may be ignored.

Variation of the junction capacitance and the junction series resistance as a function of applied reverse voltage is reported in the individual varactor data sheets of this catalog.

Silicon Versus Gallium Arsenide

While it is true that gallium arsenide diodes typically have higher Q than silicon diodes, this doesn't necessarily result in better performance. It would be expected that substituting gallium arsenide tuning diodes for silicon ones in a VCO would result in better FM noise because of the higher Q. Instead, the FM noise usually gets worse due to up-conversion of surface noise. There is no known passivation for gallium arsenide which limits surface states and the associated "1/f" noise, like thermal does in the case of silicon. For this reason, thermal oxide passivation silicon is a better choice for high power or wide band VCO's than gallium arsenide, if FM noise is a consideration.

Another reason for choosing silicon is the poor stability record of gallium arsenide diodes. Because of its higher thermal resistance, gallium arsenide does not settle as fast as silicon diodes in fast VCO's and the high surface state density in GaAs results in significant long-term drift compared to silicon.

PIN DIODES APPLICATION NOTE

PIN diodes are primarily used as control devices for both RF and microwave power in the following applications:

- Switches
- Attenuators
- Phase Shifters
- Limiters

Switches

PIN'S are most widely used as switching elements to control microwave and RF power from UHF through KU bands in a variety of switch configurations such as series, shunt, series-shunt, multi-throw and more complex multi-throw series-shunt switches.

The D.C. bias controls device impedance in the switching mode. When the bias is switched between high and low impedance modes, the circuit acts as a simple switch. For series mount applications, the switch is "on" when the diode is forward biased (low impedance), and "off" when reverse biased (high impedance). In the shunt mount, the situation is reversed; forward bias is "off" and reverse bias is "on".

The attenuation Out exists when the switch is "on" is referred to as insertion loss "IL", and when the switch is "off", it is called isolation.

Design Trade-Offs

There are a wide range of microwave PIN diodes available. The thickness of the "I" region (as well as its resistivity) and the area of the junction can vary over an almost infinite range of combinations. Design considerations such as junction capacitance, series resistance, switching Speed, carrier lifetime, power handling capability and thermal resistance can make diode selection appear overly difficult. The following set of three trade-offs can help to simplify the task.

Power Handling Versus Frequency

To maintain low loss at high frequency, C_j should be at a minimum, however, reducing junction area increases thermal resistance (θ) and hence reduces power handling capability.

Power Handling Versus Switching Speed

To increase power handling capability without increasing junction capacitance, the "I" region thickness and resistivity can be increased to allow more junction area. However, increasing "I" region width increases carrier lifetime, which decreases switching speed.

Performance Versus Frequency and Bandwidth

In a reverse bias shunt mode, the isolation and insertion loss of a PIN diode is approximately given by:

$$I_{SO} \text{ (dB)} = 20 \log Z_0/2R_F$$

$$I_L \text{ (dB)} = 160 R_R Z_0 f^2 C_j^2$$

The switching ratio is given by:

$$I_{SO}/I_L = \frac{\log Z_0/2R_F}{8 R_R Z_0 f^2 C_j^2}$$

It is apparent that these quantities decrease with an increase in frequency. To overcome the degradation of performance versus frequency, one can resonate the junction capacitance of the diode at the expense of bandwidth. The higher the operating frequency of the diode, the smaller the percentage of bandwidth is going to be, over which high performance can be maintained.

Phase Shifters

There are many configurations of phase shifters, but most operate as shunt switches placed at quarter wavelength intervals on a transmission line and configured to switch either a capacitance or an inductance onto the line. This changes the electrical length of the line and produces a corresponding phase shift.

The selection process here is much the same as for a conventional switch, but with the added complication that the diode characteristics (and parasitics) contribute to the phase shift as well, and must be taken into consideration.

PIN DIODES APPLICATION NOTE (Cont.)

Limiters

Limiters are PIN diodes designed to protect power sensitive microwave components such as detectors, mixers, and amplifiers against a variety of high power CW and pulsed microwave signals. PIN limiters utilize very thin "I" regions which results in low insertion loss at low power levels and a very fast response time.

Limiters are usually arranged in cascade where the first diode will attenuate most of the incident power and the next (thinner) diode will nearly double the attenuation, while a third (thinnest) diode "cleans up" the incident power that gets past the first two.

Limiters are characterized primarily by their power handling capability and switching speed, which determines the amount of incident power that will not be attenuated. Any initial power that gets past is referred to as spike leakage, and is a function of the response time of the fastest diode. Any power that is not attenuated by limiters in the fully turned on state is referred to as flat leakage, and is a function of the total impedance of the diodes.

STEP RECOVERY DIODES APPLICATION NOTE

Step recovery diodes, or SRD's, are used as high order multipliers and will multiply as high as 20x when used as a comb generator. They depend on extremely fast recovery time, often referred to as "snap time" to generate pulses rich in harmonics. Proper filtering and pulse shaping produces the familiar output of sharp, fast rise time pulses.

By storing charge during the positive half of an input sinusoidal signal and then "extracting" that charge during the negative going half cycle, a current pulse with a rise time equivalent to the "snap time" of the diode is generated in the impulse circuit of the multiplier. Output filtering then selects the desired harmonics for the application at hand.

Unlike C-Swing multipliers which utilize the non-linearity of the capacitance-voltage curve to generate harmonics, and are most useful as low order, high power multipliers, SRD'S are most useful as high order, low power multipliers. Because they can be made with low capacitance and low parasitics, they are most useful at the higher frequency ranges and will work with outputs as high as Ku band.

Figure 1. Capacitance Vs. Output Frequency

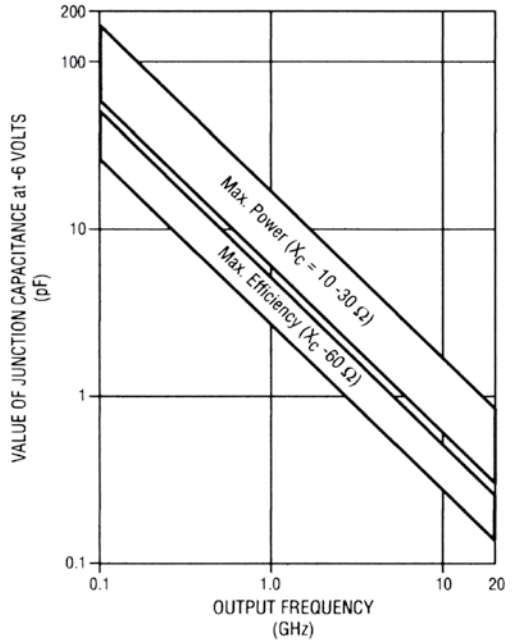
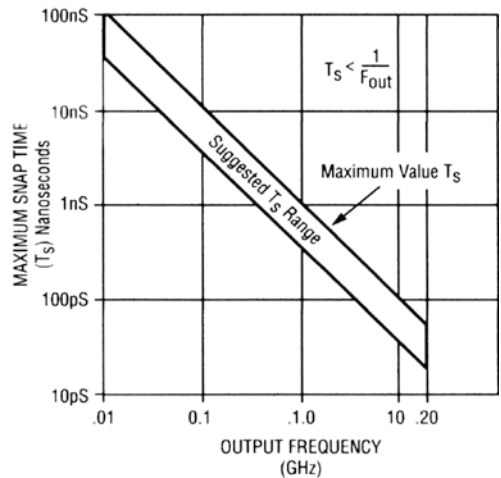

Figure 2. Snap Time Vs. Output Frequency



STEP RECOVERY DIODES APPLICATION NOTE

Selection of SRD's

In selecting a diode for comb generator operation, the following criteria should be determined:

- Input Frequency
- Output Frequency
- Bandwidth
- Efficiency

Once these values have been determined, the proper diode can be selected, as well as the proper value of the bias resistor.

The major requirement for an efficient multiplier diode is that its lifetime is long enough that the reverse current can reach a peak before the diode "snaps" back to its high impedance state.

Figure 3. Ideal Lifetime

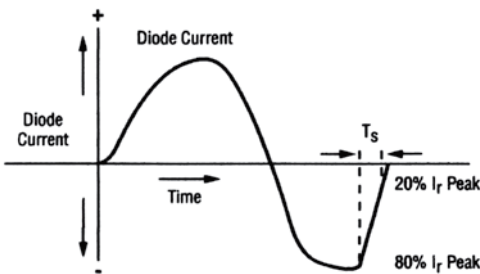
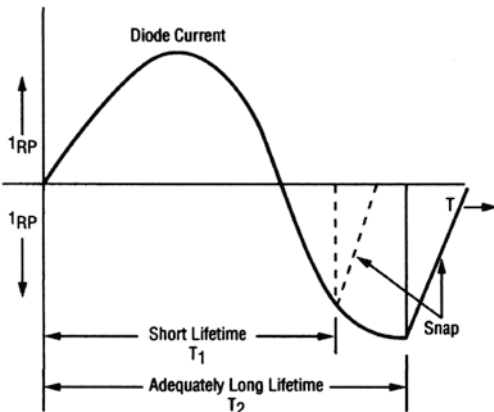

Figure 4. Snap Time (Ts) Definition



Input Frequency

The minimum required lifetime for a given input frequency can be calculated by: $TL \times FIN = 10 \text{ Min}$. However, a value of 20-30 is considered best in most applications with the exception of bandwidths of 10% or greater, where a value closer to 10 will minimize difficulties of input matching.

Output Frequency

Transition time, or snap time as we have been using, is the key determinant for optimizing output of a multiplier circuit, i.e.: $T_s < 1$

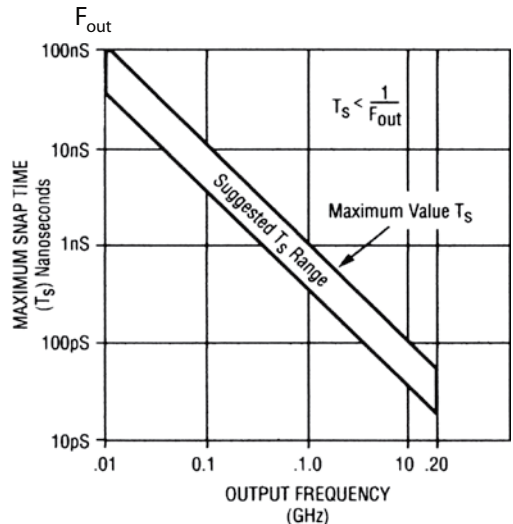

Maximum and suggested values of snaptime (T_s) for SRD varactors vs. multiplier output frequency in GHz.

Output frequency also controls the choice of junction capacitance. A multiplier will work best if the output reactance is approximately 50 ohms at the self bias point established by the bias resistor. (Usually very close to the specified capacitance -6 volts.) $C_j = \frac{1}{2\pi f X_C}$

Normally a reactance value between 30 and 60 Ohms is adequate for most multiplier applications, however since power handling is dependent on junction area, the larger the junction the better, so a reactance of 30 to 40 Ohms should be the goal.

STEP RECOVERY DIODES APPLICATION NOTE (Cont.)

Output Power

The output power required will determine the breakdown voltage needed and the thermal resistance of the diode. The breakdown voltage must be high enough so that the peak RF voltage plus the bias voltage will not cause the diode to avalanche. If this occurs, the diode will become quite noisy and could burn out. The required breakdown voltage can be estimated by:

$$Bv = k \sqrt{\frac{2P_o}{(F_{in} \times C_t - 6)}}$$

where the constant

- k = 0.8 for multiplication < 4
- = 1.1 for multiplication = 4
- = 1.5 for multiplication > 4

The thermal resistance must be low enough to keep the junction temperature below 150°C during operation (all power not converted to harmonics may be assumed to be dissipated in the diode)

$$\theta_{jo} = \frac{150^\circ\text{C} - T_A}{(\text{power in}) - (\text{power out})}$$

where T_A is the ambient temperature.

Bandwidth

Step recovery diodes are inherently narrow band due to the "spike" response nature of the input impedance. For applications requiring bandwidths of 5-10% or greater, a low order multiplier utilizing a C-Swing type diode is recommended. If a broadband comb generator is required, the input and output filters should be kept as simple as possible.

Efficiency

The principle contributor to decreased efficiency in multiplier circuits used to be the cutoff frequency of the diode. Today, however, most modern SRD and multiplier designs have cutoffs in the 200 - 300 GHz range which is more than adequate for most multipliers up to Ku band. Efficiency for most multiplier circuits can be approximated by the expression:

$$\text{Efficiency} \approx \frac{1}{n} \text{ where } n > 3$$

For doublers, efficiency as high as 65% can be achieved. For triplers, efficiency as high as 50% can be achieved.

CHIP AND BEAM LEAD HANDLING APPLICATION NOTE

Chip and beam lead devices are packaged for shipment in either waffle packs or Gel-Packs®. Chips in waffle packs are somewhat free to move around their wells, and can be accidentally dislodged rather easily when the waffle pack is opened. To prevent this, we recommend the following procedure: The waffle pack top is secured with a locking clip. Place the waffle pack on a smooth, flat surface with the label side up. Hold the waffle pack securely while slowly sliding off the clip. Carefully remove the waffle pack lid by lifting it straight up, then remove the packing material. Carefully remove chips, one at a time, using tweezers or a vacuum pick-up. NOTE: It is at this point that most damage to chips occurs, since they are most fragile at the chip corners and at the mesa edge. Since many devices shipped as chips are sensitive to damage from static discharge, we recommend that all chips be handled in ESD secure areas.

The same procedure holds for Gel-Packs® except that the devices are more securely held in place by the tacky gel surface coat. Since most devices packed this way are beam leads, a vacuum pick-up is mandatory. Attempting to handle beam leads with tweezers will result in severe deformation of the beams and probable damage to the devices.

Die Bonding

Die bonding is usually done by either solder preform or conductive epoxy die attach methods. For the lowest electrical resistance and highest mechanical strength, we recommend the use of gold/tin or gold/germanium solder preforms to form a bond between the circuit substrate and the gold backing of the chip. Conductive epoxy may be used where general or localized heating of the circuit substrate is impractical. We recommend Ablestik 184 LM1. The recommended bonding temperature for gold/tin is 280°C and 385°C for gold/

germanium. Bonding should be shielded with an inert atmosphere of Nitrogen or forming gas (Nitrogen with 10% hydrogen). Conductive epoxy should be cured for one hour @ 150°C in a Nitrogen atmosphere.

Lead Bonding

Leads to the top contact of chips may be formed by bonding gold ribbon or wire from the circuit to the contact (usually the anode) by thermo-compression bonding techniques. Here, the combination of heat and pressure causes a gold to gold metallurgical bond to form. Since the bonding process is governed by many factors, including the chip size and geometry, some trial and error will be necessary to find the right combination of heat and pressure to form a secure bond. As a starting point we recommend a bonding tip temperature of 150-165°C and a substrate temperature of 250°C. Start with a tip pressure of 40 gm. and reduce it to the minimum necessary to form a good bond.

Die Bond Criteria

GOOD BOND



- Solder or Epoxy Thin (Approx. .001" MAX)
- No Meniscus Around Edge
- Solder Surface Shiny
- No Holes, Cracks, etc.
- Minimum 90% Wet

UNACCEPTABLE BOND



- Tilted Die
- Loose or Foreign Material on Top of Chip
- Solder or Epoxy Carrier on Top of Surface of Die
- No Evidence of Dice to Substrate Melt Around at Least 10% of the Die
- Less than 90% Melting

OTHER UNACCEPTABLE BONDS



Cracked Dice



Metallization Missing



Broken Dice

QUALITY AND RELIABILITY

Massachusetts Bay Technologies

is committed to quality control which consists of total involvement with design, development, manufacturing, testing and reliability screening of all our semiconductor products.

Massachusetts Bay Technologies is firmly committed to producing quality devices free of defects and deviations. Our primary goal is to maintain consistently high standards by focusing on the following functions:

- Assuring all incoming materials conform to documented specifications.
- Assuring the calibration of all test and manufacturing equipment as well as all standard jigs and fixtures.
- Performance of all electrical and environmental screening up to and including space level.
- Responsible for maintenance, review and strict adherence to all specifications used in the manufacturing and screening of all **Massachusetts Bay Technologies** semiconductor devices.
- Responsibility for maintenance, review and strict adherence to the company's ESD program and policies.

Massachusetts Bay Technologies

is a certified ISO 9001:2008 facility. This system has facilitated **Massachusetts Bay Technologies'** transition to a military/commercial manufacturing operation.

Screening Procedures

Massachusetts Bay Technologies provides standard high reliability test programs for our entire product line. These programs are based on MIL-STD-19500, MIL-STD-750 for components assuring the use of our products in military and space applications.

The following tables are suggested screening requirements We offer three levels of high reliability testing at the TX, TXV and S levels.

Table 1. Semiconductor Capacitor/Inductor Element Evaluation

Screen	MIL-STD-750 Method	Level Requirements	
		K	H
Subgroup 1			
Internal Visual		X	X
Stabilization Bake	1031	X	
Temperature Cycle	1051	X	
Acceleration	2006	X	
Visual Inspection	2071	X	
Electrical Test		X	X
Subgroup 2			
Bond Pull	2037	X	X

Notes:

1. Capacitor testing to include: I_p, V_b, C_p; Inductor testing to include: R_s.
2. Test sequence IAW MIL-38534. Actual test methods and conditions IAW MIL-STD-883.

QUALITY AND RELIABILITY (Cont.)

Table 2. Semiconductor Package Diode 100% Process Conditioning Screening

Test Inspection Note 1	MIL-STD-750 Method	Level Requirements		
		S	TXV	TX
Internal Visual	2074 or 2073	100%	100%	N/A
Stabilization Bake	1032	100%	100%	100%
Temperature Cycle	1051	100%	100%	100%
Acceleration	2006	100%	100%	100%
PIND	2062	100%	N/A	N/A
FIST	2061	100%	N/A	N/A
BIST	2062	100%	N/A	N/A
Fine Leak	1071	N/A	100%	100%
Gross Leak	1071	N/A	100%	100%
Initial Electrical Test	Note 3	100%	100%	100%
Burn-In	Note 2	100%	100%	100%
Interim Electrical Test	Note 3	100%	100%	100%
Burn-In	Note 2	100%	100%	100%
Final Electrical Test	Note 3, 4, 5	100%	100%	100%
PDA	Note 4			
Fine Leak	1071	100%	N/A	N/A
Gross Leak	1071	100%	N/A	N/A
X-Ray	2076	100%	N/A	N/A
External Visual	2071	100%	N/A	N/A

Notes:

1. The Actual Test methods and conditions vary depending upon component type and packaging.
2. Burn-In methods and conditions vary with components type, packing and ratings
3. Electrical tests performed are selected for each device type and usually consists of some or all of the following:
C_i, V_f, R_s.
4. The PDA for S level is 5%, TXV, TX is 10%.
5. Small lot sample size is applicable for inspection lots containing less than 500 pcs.

Table 3. Quality Conformance Inspection, Group A (all levels)

Inspection	MIL-STD 750 Method	Sample Plane	Small Lot
Subgroup 1 Visual Mechanical	2071	45 Devices, c = 0	45 Devices, c = 0
Subgroup 2 Electrical Test	Note 1, 2, 3, 4	116 Devices, c = 0	45 Devices, c = 0
Subgroup 3 Electrical Test	Note 1, 2, 3, 5	116 Devices, c = 0	45 Devices, c = 0
Subgroup 4 Electrical Test	Note 1, 2, 3, 4	116 Devices, c = 0	45 Devices, c = 0

Notes:

1. Electrical testing will consist of I_r, MIN. rated V_b, and V_f testing, except that V_b, will not be performed on Schottky devices. Test limits at temperature may vary from those published. Consult factory for more information. Variables data supplied for S level inspection lots.
2. All devices shall be subjected to subgroups 2, 3 and 4 combined.
3. Small lot sample size is applicable for inspection lots containing less than 500 pcs.
4. TA=+25°C
5. TA = MIN and MAX rated operating temperatures.

QUALITY AND RELIABILITY (Cont.)

Table 4. Semiconductor Diode Group B Inspection

Subgroup	Test Inspection	MIL-STD-750 Method	Level Requirements	
			S	TX & TXV
1	Physical Dimensions	2066	Sample	N/A
	Solderability	2026	Sample	Sample
	Resistance to Solvents	1022	Sample	Sample
2	Temperature Cycle	1051, Note 1	Sample	Sample
	Thermal Shock	1056, Note 2	Sample	Sample
	Fine Leak	1071	Sample	Sample
	Gross Leak	1071	Sample	Sample
	Electrical Test	Note 3	Sample	Sample
3	Steady State Life	1027	Sample	Sample
	Electrical Test	Note 3	Sample	Sample
	Decap Internal Visual	2075	Sample	Sample
	Bond Strength	2037	Sample	Sample
	Die Shear	2017	Sample	N/A
4	Operation Life	Note 4	Sample	N/A
	Electrical Test	Note 3	Sample	Sample
5	Thermal Resistance	Note 4	Sample	Sample
6	High Temperature Storage	1032	N/A	Sample
	Electrical Test	Note 3	N/A	Sample

Table 5. Semiconductor Diode Group C Inspection

Subgroup	Test Inspection	MIL-STD-750 Method	Level Requirements	
			S	TX & TXV
1	Physical Dimensions	2066	N/A	Sample
2	Thermal Shock	1056, Note 1	Sample	Sample
	Terminal Strength	2036, Note 2	Sample	Sample
	Fine Leak	1071	Sample	Sample
	Gross Leak	1071	Sample	Sample
	Moisture Resistance	1021	Sample	Sample
	Electrical Test	Note 3	Sample	Sample
3	Shock	2016	Sample	Sample
	Vibration Variable Frequency	2056	Sample	Sample
	Acceleration	2006	Sample	Sample
	Electrical Test	Note 3	Sample	Sample
4	Salt Atmosphere	1041	Sample	Sample
5	N/A			
6	Steady State Life	Note 4 (t = 1000 Hrs)	Sample	Sample
	Electrical Test	Note 3	Sample	Sample

Notes for Table 4 and 5:

1. Testing does not apply in axial leaded devices.
2. Testing applies to axial leaded devices only.
3. Electrical tests performed are selected for each device type and usually consists of some or all of the following:
C_v, V_r, R_s.
4. Methods and conditions vary with components type, packaging and ratings.

Ordering Procedures And Warranty Information

HOW TO TO ORDER

Orders may be placed directly with MBT, Inc. sales or with your local MBT sales representative.

Massachusetts Bay Technologies

378 Page Street
Stoughton MA 02072
Telephone: 781-344-8809
FAX: 781-341-8177

SHIPPING

Domestic and International shipments from the MBT factory are billed F.O.B. Stoughton, Massachusetts.

DELIVERY TERMS & PRICE

The price and delivery of any item in this catalog is available from either our sales department or a sales representative. Quotations are F.O.B. MBT factory and are subject to revision without notice. Terms are net 30 days if credit has been established.

PRODUCT AVAILABILITY & QUANTITY DISCOUNTS

Our factory inventory provides prompt and reliable shipment of our most popular products. Discounts are available for large quantity orders.

WARRANTY

MBT warrants their products to the original purchaser to be free of defects in material and workmanship. MBT's obligation under this warranty is limited to repair, exchange, or credit. At MBT's judgment, the warranty is limited to one year from shipment date; our warranty is not applicable to devices that have been altered, mishandled, abused, or accidentally damaged.

RETURNS

Please contact the MBT sales department before returning material/product for repair or replacement. Once authorized for return, please enclose complete description as to what issue or concern is with returned product, purchase order number, and return address for product to be re-shipped.

SPECIFICATIONS

MBT reserves the right to revise, change, or discontinue specifications on any of their products without notice.

APPLICATION ENGINEERING ASSISTANCE

MBT engineering assistance is available to provide expertise and direction for your specific component design and application needs.

FEDERAL SUPPLY CODE

Massachusetts Bay Technologies Federal Supply Code For Manufacturers Assigned Number is 1W7D7.

Index For Part Numbers

Abrupt Tuning Varactors

MBT3000.....	1-2
MBT3001.....	1-2
MBT3002.....	1-2
MBT3003.....	1-2
MBT3004.....	1-2
MBT3005.....	1-2
MBT3006.....	1-2
MBT3007.....	1-2
MBT3008.....	1-2
MBT3009.....	1-2
MBT3010.....	1-2
MBT3011.....	1-2
MBT3012.....	1-2
MBT3013.....	1-2
MBT3014.....	1-2
MBT3015.....	1-2
MBT3016.....	1-2
MBT3017.....	1-2
MBT3018.....	1-2
MBT3019.....	1-2
MBT3020.....	1-2
MBT3021.....	1-2
MBT3022.....	1-2
MBT4500.....	3-4
MBT4501.....	3-4
MBT4502.....	3-4
MBT4503.....	3-4
MBT4504.....	3-4
MBT4505.....	3-4
MBT4506.....	3-4
MBT4507.....	3-4
MBT4508.....	3-4
MBT4509.....	3-4
MBT4510.....	3-4
MBT4511.....	3-4
MBT4512.....	3-4
MBT4513.....	3-4
MBT4514.....	3-4
MBT4515.....	3-4
MBT4516.....	3-4
MBT4517.....	3-4
MBT4518.....	3-4
MBT4519.....	3-4
MBT4520.....	3-4
MBT4521.....	3-4
MBT4522.....	3-4
MBT6000.....	5-6
MBT6001.....	5-6
MBT6002.....	5-6
MBT6003.....	5-6
MBT6004.....	5-6

MBT6005.....	5-6
MBT6006.....	5-6
MBT6007.....	5-6
MBT6008.....	5-6
MBT6009.....	5-6
MBT6010.....	5-6
MBT6011.....	5-6
MBT6012.....	5-6
MBT6013.....	5-6
MBT6014.....	5-6
MBT6015.....	5-6
MBT6016.....	5-6
MBT6017.....	5-6
MBT6018.....	5-6
MBT6019.....	5-6
MBT6020.....	5-6
MBT6021.....	5-6
MBT6022.....	5-6
MBT9000.....	7-8
MBT9001.....	7-8
MBT9002.....	7-8
MBT9003.....	7-8
MBT9004.....	7-8
MBT9005.....	7-8
MBT9006.....	7-8
MBT9007.....	7-8
MBT9008.....	7-8
MBT9009.....	7-8
MBT9010.....	7-8
MBT9011.....	7-8
MBT9012.....	7-8
MBT9013.....	7-8
MBT9014.....	7-8
MBT9015.....	7-8
MBT9016.....	7-8
MBT9017.....	7-8
MBT9018.....	7-8
MBT9019.....	7-8
MBT9020.....	7-8
MBT9021.....	7-8
MBT9022.....	7-8
HF Hyperabrupt Tuning Varactors	
MBV7401.....	9
MBV7402.....	9
MBV7403.....	9
MBV7501.....	9
MBV7502.....	9
MBV7503.....	9
MBV7601.....	9
MBV7602.....	9
MBV7603.....	9
MBV7701.....	9

MBV7702.....	9
MBV7703.....	9
MBV7801.....	9
MBV7802.....	9
MBV7803.....	9

VHF Hyperabrupt Tuning Varactors

MBV8001.....	10
MBV8002.....	10
MBV8003.....	10
MBV8004.....	10
MBV8005.....	10
MBV8101.....	10
MBV8102.....	10
MBV8103.....	10
MBV8104.....	10
MBV8105.....	10
MBV8201.....	10
MBV8202.....	10
MBV8203.....	10
MBV8204.....	10
MBV8205.....	10
MBV8301.....	10
MBV8302.....	10
MBV8303.....	10
MBV8304.....	10
MBV8305.....	10
MBV8401.....	10
MBV8402.....	10
MBV8403.....	10
MBV8404.....	10
MBV8405.....	10

UHF Hyperabrupt Tuning Varactors

MBV8501.....	11
MBV8502.....	11
MBV8503.....	11
MBV8504.....	11
MBV8505.....	11
MBV8506.....	11
MBV8507.....	11
MBV8601.....	11
MBV8602.....	11
MBV8603.....	11
MBV8604.....	11
MBV8605.....	11
MBV8606.....	11
MBV8607.....	11

Microwave Hyperabrupt Tuning Varactors

MBV8700A.....	12
MBV8700B.....	12
MBV8700C.....	12
MBV8700D.....	12

MBV8700E	12	MSR15B.....	16-17	MBP100D	18-21
Low Cost UHF Hyperabrupt Tuning Varactors		MSR15C.....	16-17	MBP100E.....	18-21
MBV8801.....	13	MSR15D.....	16-17	MBP100F.....	18-21
MBV8802.....	13	MSR17A.....	16-17	MBP200A.....	18-21
MBV8803.....	13	MSR17B.....	16-17	MBP200B.....	18-21
Silicon Multiplier Diodes		MSR17C.....	16-17	MBP200C.....	18-21
1N5149	14	MSR17D.....	16-17	MBP200D	18-21
1N5150	14	MSR19A.....	16-17	MBP200E.....	18-21
1N5150A.....	14	MSR19B.....	16-17	MBP200F.....	18-21
1N5151	14	MSR19C.....	16-17	Medium Power, General Purpose	
1N5152	14	MSR19D.....	16-17	MBP200G	18-21
1N5153	14	MSR23A.....	16-17	MBP200H.....	18-21
1N5152A.....	14	MSR23B.....	16-17	MBP200I.....	18-21
1N5153A.....	14	MSR23C.....	16-17	MBP200J.....	18-21
1N5154	14	MSR23D.....	16-17	MBP200K.....	18-21
1N5155	14	MSR25A.....	16-17	MBP200L.....	18-21
1N5155A.....	14	MSR25B.....	16-17	MBP200M.....	18-21
1N5156	14	MSR25C.....	16-17	MBP200N.....	18-21
1N5157	14	MSR25D.....	16-17	MBP200O.....	18-21
Super Power Multiplier Diodes		MSR27A.....	16-17	MBP200P.....	18-21
MPD711A	15	MSR27B.....	16-17	MBP200Q.....	18-21
MPD712A	15	MSR27C.....	16-17	MBP200R.....	18-21
MPD714A	15	MSR27D.....	16-17	MBP200S.....	18-21
MPD716A	15	MSR29A.....	16-17	MBP200T.....	18-21
MPD718A	15	MSR29B.....	16-17	High Power Switching & Attenuation	
MPD720A	15	MSR29C.....	16-17	MBP250A.....	18-21
Standard Power Multiplier Diodes		MSR29D.....	16-17	MBP250B.....	18-21
MPD801.....	15	MSR33A.....	16-17	MBP250C.....	18-21
MPD802.....	15	MSR33B.....	16-17	MBP250D.....	18-21
MPD803.....	15	MSR33C.....	16-17	MBP250E.....	18-21
MPD804.....	15	MSR33D.....	16-17	MBP500A.....	18-21
MPD805.....	15	MSR35A.....	16-17	MBP500B.....	18-21
MPD806.....	15	MSR35B.....	16-17	MBP500C.....	18-21
MPD807.....	15	MSR35C.....	16-17	MBP500D.....	18-21
MPD808.....	15	MSR35D.....	16-17	MBP500E.....	18-21
MPD809.....	15	MSR37A.....	16-17	MBP500F.....	18-21
MPD810.....	15	MSR37B.....	16-17	MBP500H.....	18-21
MPD811.....	9	MSR37C.....	16-17	MBP500I.....	18-21
MPD812.....	15	MSR37D.....	16-17	MBP1000A.....	18-21
MPD813.....	15	Pin Diodes Ultra Fast Switching		MBP1000B.....	18-21
MPD814.....	15	MBP25A.....	18-21	MBP1000C.....	18-21
MPD815.....	15	MBP25B.....	18-21	Limiter Diodes	
Step Recovery Diodes		MBP25C.....	18-21	MLD5113.....	22
MSR10A.....	16-17	MBP25D.....	18-21	MLD5114.....	22
MSR10B.....	16-17	Fast Switching, Low Power		MLD5115.....	22
MSR10C.....	16-17	MPB70A.....	18-21	MLD5116.....	22
MSR10D.....	16-17	MBP70B.....	18-21	MLD5117.....	22
MSR13A.....	16-17	MBP70C.....	18-21	MLD5118.....	22
MSR13B.....	16-17	MBP70D.....	18-21	MLD5119.....	22
MSR13C.....	16-17	MBP70E.....	18-21	MLD5120.....	22
MSR13D.....	16-17	MBP100A.....	18-21	MLD5121.....	22
MSR15A.....	16-17	MBP100B.....	18-21	MLD5122.....	22
		MBP100C.....	18-21		

MLD5123.....	22	MSH1403.....	26	MHQ904.....	31
MLD5124.....	22	MSH1404.....	26	MHQ905.....	31
Beam Lead Diodes		MSH1405.....	26	Phase Detectors	
MBL5201.....	23	MSH1406.....	26	MSPD-001.....	32
MBL5202.....	23	MSH1407.....	26	MSPD-002.....	32
MBL5203.....	23	MSH1408.....	26	MSPD-003.....	32
MBL5204.....	23	MSH1409.....	26	MSPD-004.....	32
MBL5205.....	23	MSH1410.....	26	MSPD-005.....	32
MBL5206.....	23	MSH1411.....	26	MSPD-006.....	32
MBL5207.....	23	MSH1412.....	26	MSPD-007.....	32
MBL5208.....	23	MSH1413.....	26	MSPD-008.....	32
MBL5209.....	23	MSH1414.....	26	MSPD-009.....	32
MBL5210.....	23	MSH1415.....	26	MSPD-010.....	32
MBL5211.....	23	MSH1416.....	26	MSPD-011.....	32
Schottky Barrier Mixer and Detector Diodes		Zero Bias Schottky Mixer Diodes		MSPD-012.....	32
Low Barrier		MBZ100.....	27	MSPD-013.....	32
MSL1201.....	24	MBZ101.....	27	Point Contact Diodes	
MSL1202.....	24	MBZ102.....	27	Ka Band Mixer Diodes	
MSL1203.....	24	MBZ103.....	27	1N53.....	33
MSL1204.....	24	MBZ104.....	27	1N53A.....	33
MSL1205.....	24	MBZ105.....	27	1N53B.....	33
MSL1206.....	24	MBZ106.....	27	1N53C.....	33
MSL1207.....	24	MBZ107.....	27	1N53D.....	33
MSL1208.....	24	MBZ108.....	27	1N78.....	33
MSL1209.....	24	MBZ109.....	27	1N78A.....	33
MSL1210.....	24	MBZ110.....	27	1N78B.....	33
MSL1211.....	24	General Purpose Schottky Diodes		1N78C.....	33
MSL1212.....	24	MGS1801.....	28	1N78D.....	33
MSL1213.....	24	MGS1802.....	28	1N78E.....	33
MSL1214.....	24	MGS1803.....	28	1N78F.....	33
MSL1215.....	24	MGS1804.....	28	1N78G.....	33
MSL1216.....	24	MGS1805.....	28	S-X Band Mixer Diodes	
Medium Barrier		MGS1806.....	28	1N21C.....	34
MSM1301.....	25	Low Barrier Schottky Ring Quad		1N21D.....	34
MSM1302.....	25	MLQ700.....	29	1N21E.....	34
MSM1303.....	25	MLQ701.....	29	1N21WE.....	34
MSM1304.....	25	MLQ702.....	29	1N21F.....	34
MSM1305.....	25	MLQ703.....	29	1N21G.....	34
MSM1306.....	25	MLQ704.....	29	1N21WG.....	34
MSM1307.....	25	MLQ705.....	29	1N416C.....	34
MSM1308.....	25	Medium Barrier Schottky Ring Quad		1N416D.....	34
MSM1309.....	25	MMQ800.....	30	1N416E.....	34
MSM1310.....	25	MMQ801.....	30	1N416F.....	34
MSM1311.....	25	MMQ802.....	30	1N416G.....	34
MSM1312.....	25	MMQ803.....	30	1N23.....	34
MSM1313.....	25	MMQ804.....	30	1N23A.....	34
MSM1314.....	25	MMQ805.....	30	1N23B.....	34
MSM1315.....	25	High Barrier Schottky Ring Quad		1N23C.....	34
MSM1316.....	25	MHQ900.....	31	1N23D.....	34
MSH1401.....	26	MHQ901.....	31	1N23E.....	34
MSH1402.....	26	MHQ902.....	31	1N23F.....	34
		MHQ903.....	31	1N23G.....	34

1N23WG	34
1N23H	34
1N415C	34
1N415D	34
1N415E	34
1N415F	34
1N415G	34
1N415H	34

X Band Mixer Diodes

1N831	35
1N831A	35
1N831B	35
1N831C	35
1N832.....	35
1N832A	35
1N832B	35
1N832C	35

Ka Band Detector Diodes

1N830.....	36
1N830A	36
1N32.....	36
1N32A	36
1N833.....	36
1N833A	36
1N1611	36
1N1611A.....	36
1N1611B.....	36
1N3778	36

Passive Components

MIS Chip Capacitors

MCC1100.....	37-38
MCD2100	37-38

MIC Mounting Capacitors

MBT1-MBT6 SERIES	39
------------------------	----

Binary Chip Capacitors

MBA Series	40
MBB Series	40

Spiral Inductors

MSI201.....	41
MSI202.....	41
MSI203.....	41
MSI204.....	41
MSI205.....	41
MSI206.....	41
MSI207.....	41
MSI208.....	41
MSI209.....	41
MSI210.....	41

Thin Film Resistor Chips

MRT Series	42
------------------	----

Thin Film Attenuator Pads

MAP Series	44
------------------	----



Massachusetts Bay Technologies

378 Page Street, Stoughton, MA 02072

Tel: 781-344-8809 • Fax: 781-341-8177

Email: sales@massbaytech.com

www.massbaytech.com