



ALMA MATER STUDIORUM
UNIVERSITÀ DI BOLOGNA

Report on heat production during preliminary tests on the Rossi “Ni-H” reactor

Dr. Giuseppe Levi

In this first and preliminary document are reported the heat production measures done during two short tests done on December 16 2010 [Test 1] and January 14 2011 [Test 2].

On December, 16 2010 I had the opportunity to test, for the first time, a prototype of the Rossi “Ni-H” reactor. A photograph of the apparatus used in both tests is shown in fig.1 and a scheme is shown in fig. 2.



Fig.1

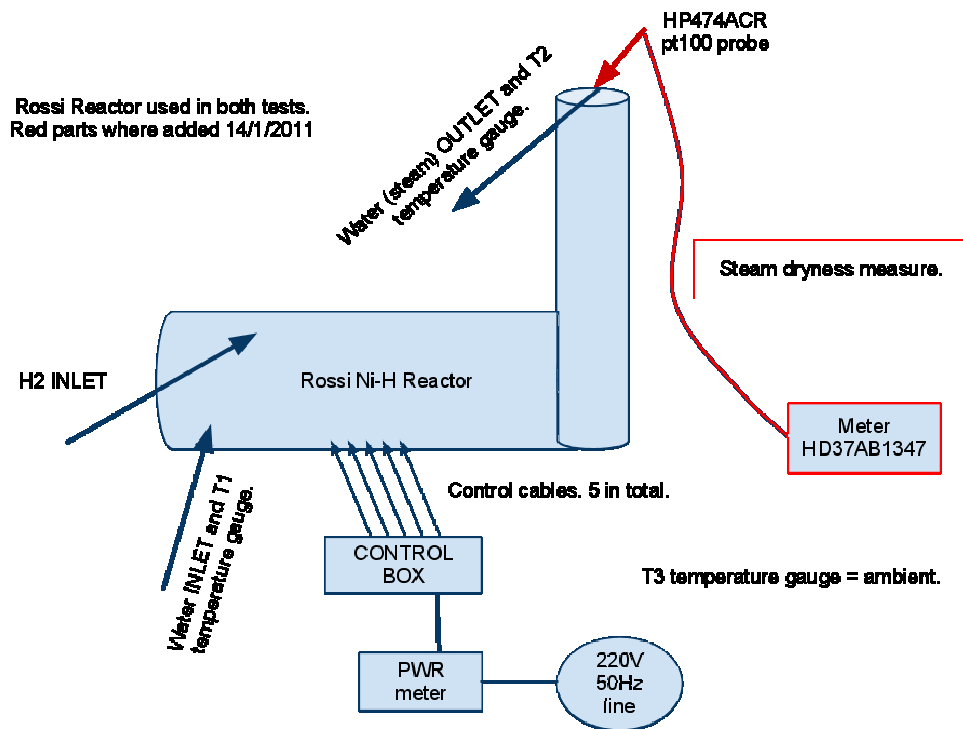
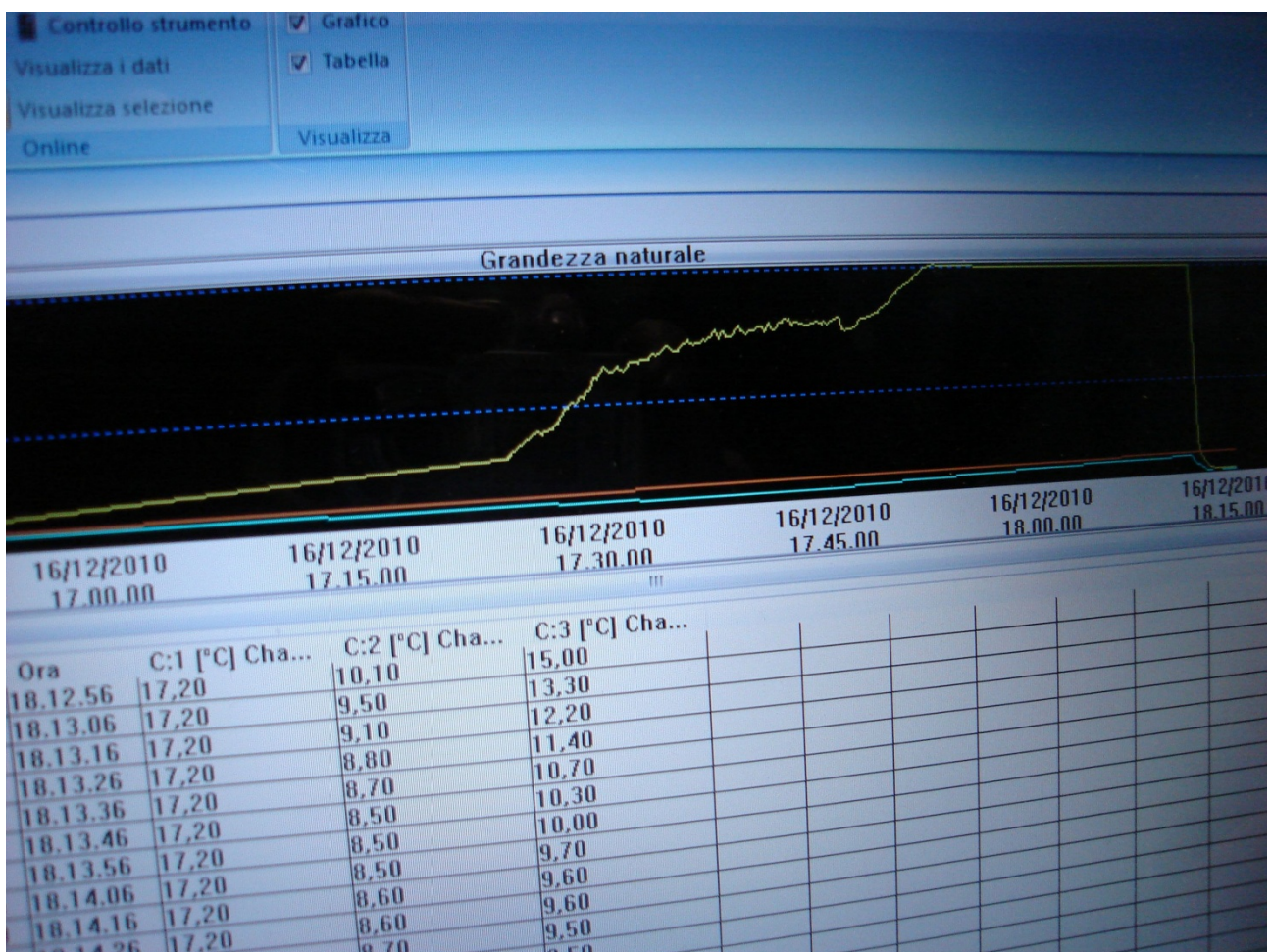

Fig.2

The Rossi Reactor prototype has a main horizontal cylindrical body ending with a vertical pipe. The H₂ inlet was connected to a Hydrogen bottle through no return valves. There was no H₂ outlet apart from a small purge valve that was closed. Cables were connected to a control box with 5 digital plc that were “controlling the power sent to the resistors inside the reactor”. Prudentially I have lifted the control box in search for any other eventually hidden cable and found none. The weight of the control box was of few Kg. Two water pipes were connected to the system. Temperature was measured and logged by two NTC sensors. Another sensor, in the logger, was measuring the ambient temperature. Power from the 220V line was monitor and logged by a “WATTS UP?” Pro Es power meter.

Before igniting the reactor the water flux was set and measured by collecting, , and then weighting, an amount of water in a container in a given time. The measured flux was of 168 +/- 2 g in 45 +/- 0.1 s.

Then the power was turned on an temperatures started to rise. In Fig 3 is shown a plot of the temperatures as appeared on the monitor during the test taken from the start to just after the end of the test.



The three lines refers:

(B) blue line: T1 water input temperature

(Y) yellow line: T2 water (steam) output temperature

(R) red line : ambient temperature

As it can be seen the system was turned on just around 16.55. After approx 30 minutes a kink can be observed in the (Y). Because input power (1120W also checked via and clamp amperometer) was not modified (see fig.5 later) this change of slope testify that the reactor was ignited. After a startup period approx 20 minutes long were the reactor power was almost constant taking the water to $\approx 75\text{ }^{\circ}\text{C}$ a second kink is found when the reactor fully ignites rising the measured temperature at $101.6 \pm 0.1\text{ }^{\circ}\text{C}$ and transforming the water in to steam.

At this point we can try a simple calculus in order to evaluate the power produced. In order to raise the temperature of 168 g of water by $1\text{ }^{\circ}\text{C}$, $\approx 168 * 4.185 = 703\text{ J}$ are needed. The water inlet temperature was $15\text{ }^{\circ}\text{C}$ so the ΔT was $85\text{ }^{\circ}\text{C}$. We have $703 * 85 = 59755\text{ J}$. At this energy one must add the evaporation heat $\approx 2272\text{ J/g} * 168 = 381696\text{ J}$. Total energy in 45 sec is $59755 + 381696 = 441451\text{ J}$, and power is $441451 / 45 = 9810\text{ W}$. Statistical experimental errors in power estimation, due mainly to flux measurements, can be conservatively estimated in about 1.5%. In this case we have $\pm 150\text{ W}$.

This result is only a lower limit of the energy produced because the system was not completely isolated and we have not taken into account any heat loss. From the calculation of the “produced power” when the water was at $75\text{ }^{\circ}\text{C}$ which give a result that is less than the electrical input power is easy to understand that this systematic under estimation surely exceeds the statistical errors .

Before ending [Test1] all the power was reduced and then switched off from the resistors and also the hydrogen supply was closed. No pressure decrease was noted in the H2 bottle. Even in this conditions the system kept running self sustaining, for about 15 minutes until it was decided to manually stop the reaction by cooling the reactor using a large water flux (note the decrease of the water input temperature).

The main origin of possible errors in [Test1] measure was that the steam was not checked to be completely dry. During [Test2] this measure was done by Dr. Galantini a senior chemist who has used an “air quality monitor” instrument HD37AB1347 from Delta Ohm with a HP474AC probe . Also in [Test2] a high precision scale (0.1g) was used to weight the Hydrogen bottle (13 Kg) before $13666.7 \pm 0.1\text{ g}$ and after $13668.3 \pm 0.1\text{ g}$ the experiment. The cause of this unexpected

rise was traced to be the remnant of piece of adhesive tape used to fix the bottle during the experiment. After careful examination of the tape the weight loss was evaluated to be <1g. This is far less the expected weight loss due to chemical burning. In fact 1g of H can produce (max) 128 kJ. In [Test2] the power measured was 12686 +/- 211 W for about 40 min with a water flux 146.4g +/- 0.1 per 30 +/- 0.5 s. The mean input power during the test was 1022 W. This means that $11664 * 40 * 60 = 27993600$ J were produced. As stated before this is only a lower limit.

Dividing this number by 128kJ a weight of 218g is obtained, two order of magnitude larger than the H consumption observed.

As a prudential check the reactor was lifted to seek any eventually hidden power cord. None was found.

During the test the main resistor, used to ignite the reaction, failed due to defective welding. Even in that condition the reactor successfully started operation using the other resistors but the duration of the experiment in full power (≈ 40 min) was “too short” to observe a self sustaining reaction.

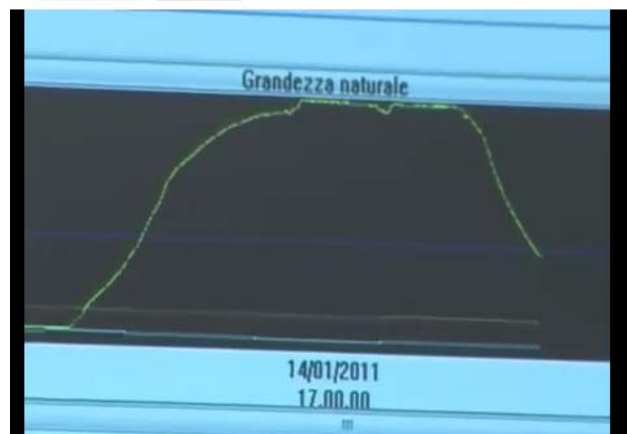

The temperatures recorded in [Test 2] are shown in fig 4. Unfortunately the original data has been lost but the different evolution is evident.

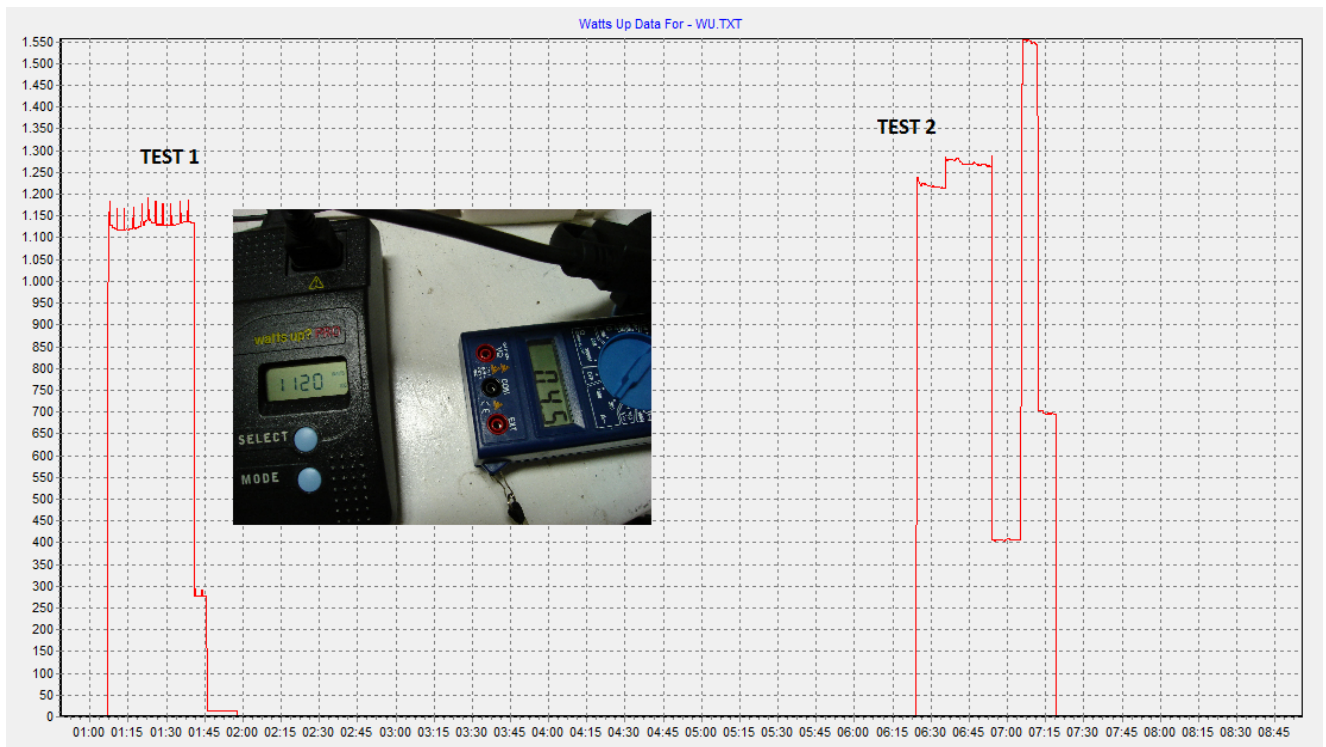

Fig. 5 Power adsorbed during tests in W. The time abscissa has 15min tics from counted from the first record. Spikes in [Test 1] are due to line voltage spikes. The anomalous behavior in [Test 2] is clear.

The average power adsorbed during [Test 2] is $\approx 1022\text{W}$.

Conclusions

The amount of power and energy produced during both tests is indeed impressive and, together with the self sustaining state reached during [Test 1] could be an indication that the system is working as a new type of energy source of unknown origin. The short duration of the tests suggests that is important to make more long and complete experiments. An appropriate scientific program will be draw.

Dott. Bianchini David
Physics Department - University of Bologna
Viale Bertè Pichat 6/2 - 40127 Bologna

Kind attention of
EFA srl
Via Marsili 4
40100 Bologna
c.f. e P.iva: 02826781208

Bologna 21/01/2011

Experimental evaluation, for radiation protection purpose, of photon and neutron radiation field during the public presentation of the prototype called "Energy Amplifier"

PREFACE

On 14/01/11 at the GM System plant of Via dell'Elettricista 16 in Bologna, I performed radiation field measurements for radiation protection purposes as per your request of 09/11/10.

This report is therefore about the evaluation of the photon and neutron radiation field near the prototype called "Energy Amplifier" during its public presentation.

The process, the geometry and the materials used for the production of energy inside the "Energy Amplifier" are unknowns that I'm not aware of. Environmental monitoring is defined temporally before, during and after the test in question

The field evaluation can not relate to criteria of functionality of the system and can not be used for comparison in systems different from this one, in the process, in the geometry or in the construction materials used.

TIME DESCRIPTION OF THE TEST

The test has been conducted without interruptions in the measures presented below, which therefore represent, to all intents and purposes, a continuous monitoring of the photon field and of the neutron field samples as summarized in table:

ID	Phase	Start time	End time
0	External environmental background	13:10	13:20
1	Before ignition	15:45	16:22
2	Ignition	16:22	16:45
3	Stability	16:45	17:25
4	Switching off	17:25	17:55
5	After switching off	17:55	19:00

Table 1: Time phases of the present measures during the presentation of the "Energy Amplifier".

REPRESENTATION OF THE MEASURE GEOMETRY

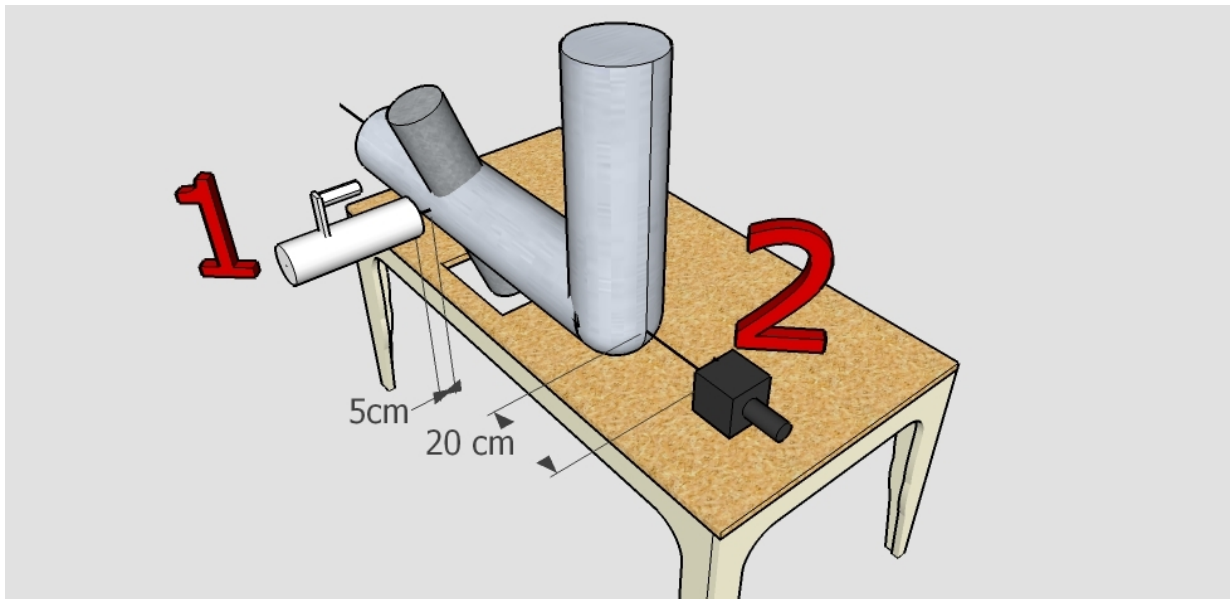

Figure1: This is the prospective representation of the relative position between probes and the “Energy Amplifier”. This figure can be used to represent the environment in which the instruments were used. Probe”1”: as describe in Table 2. Probe”2”: as describe in Table 4

EVALUATION OF THE X e γ FIELD

This measure has the purpose of detecting, only for radiation protection purposes, the X e γ radiation around the “Energy amplifier” during it's using.

This measure does not take into account in any way the internal attenuation of the photons produced by the apparatus and can not in any way be traced back to the production or otherwise of the photons due to the same apparatus.

METHOD

Has been defined a measurement protocol structured as follows:

- In agreement with the ICRU defininitions (*International Commission on Radiation Units and Measurements; rif. Report 57-1998*), we have chosen to evaluate the ambient dose equivalent $H^*(10)$ as a dosimetric indicator of the X and γ field;
- The ambient dose equivalent measurements have been performed in dose rate mode;
- The measurement position is not fixed but is variable around the “Energy amplifier” at a minimum distance of measurement from the outer structure equal to $d=(5\pm 2)$ cm. This choice has the purpose of monitoring the possible anisotropic radiation through the mapping of the radiation solid angle around the system;
- The measurements have been repeated at a frequency such that the average of the values is magnitude representative of the dosimetric values distribution;
- The average values are both temporal (time phase) and spatial (different positions of measurement);
- The analysis of the data is based on the comparison with the environmental background measured in an independent temporal phase (phase 0) and in an environment reasonably far from the “Energy amplifier” ($d>50m$).

MATERIALS

The measurements were performed with the following instrumentation:

• AUTOMESS 6150 AD-b (s/n 93883);
• Last calibration certificate SIT 065/R n. 9521/S/12/10 del 20.12.2010);
• Probe: zinc sulfide (ZnS scintillator) size 3” \times 3”;
• Measuring range 23 keV – 7 MeV;
• Resolution declared of 1 nSv/h;
• Measuring range of 50 nSv/h – 99.99 μ Sv/h.

Table 2: Specification data of the used instrument for the present measure.

RESULTS

The measured values are shown in the following table:

Temporal Phase	H*(10) [nSv/h]
0	118 ± 10%
1	107 ± 10%
2	111 ± 10%
3	115 ± 10%
4	116 ± 10%
5	123 ± 10%

Table 3: Ambient dose equivalent for each test phase as described in Table 1 (Please note that Phase 0 correspond to the background value)

The uncertainty on the measure is estimated in accordance with the methods described in ICRU Report 76 *Measurement Quality Assurance for Ionizing Radiation Dosimetry (2006)*.

CONCLUSIONS

From the measures it is shown that there are no evidence of meaningful differences of H*(10) compared to the background environmental radiation.

Furthermore the dosimetric measures are not dissimilar from the environmental background measurement both as average and as maximum peak values.

EVALUATION OF THE NEUTRON FIELD

This measure has the purpose of detecting, only for radiation protection purposes, the neutron radiation around the “Energy amplifier” during its using.

The measure does not take into account in any way the attenuation and the thermalization of neutrons maybe produced or present inside the apparatus and can not be in any way be traced back to the production or otherwise of neutrons due to the same apparatus.

MATERIALS

For the measurement we used a direct reading electronic detector described by the following technical summary:

<i>Manufacturer:</i>	LUDLUM
<i>Electrometer:</i>	LUDLUM 2221 Scaler/Ratemeter SCA
<i>Probe:</i>	Prescila 42-41 Neutron Radiation Detector (neutron recoil scintillator)
<i>Sensitivity declared by the manufacturer:</i>	350 cpm per mrem/h;
<i>Angular dependance:</i>	15 % in all the measure range

Table 4: Specification data of the used instrument for the present measure.

The instrument has been periodically calibrated by an accredited ENEA center that has provided the following calibration factors:

- On 17/03/2010 (N°1N10) with AmBe source ($E_{\text{neutrons}} = 4.4 \text{ MeV}$) equal to 36CPM per $\mu\text{Sv/h}$
- On 28/01/08 with di Pu-Li source ($E_{\text{neutrons}} = 0.54 \text{ MeV}$) equal to 15 cpm per $\mu\text{Sv/h}$

METHOD

Has been defined a measurement protocol structured in the following way:

- The evaluation of the neutron field is based on the rate measurement of the counts per minutes (cpm) so as they are provided by the instrument, by integrating the registered counts in 60 seconds;
- The measurement position is fixed with respect to the “Energy amplifier” at measurement distance from the external structure equal to $d = (20 \pm 5) \text{ cm}$. This choice has the purpose to monitoring the neutron radiation in the room in the chosen angular direction. The choice of the position is due the instrument available space;
- The values provided are the average of the values collected in the temporal interval;
- The measurements have been repeated at a frequency such that the average of the values is representative of the distribution of dosimetric values;

- The analysis of the data is based on the comparison with the background measured in an independent temporal phase (phase 0) and in an environment reasonably far from the “Energy amplifier” (d>50m).

RESULTS

The results are presented in temporal rate of counts per minutes type (counts per minutes) in the same way as what is provided directly by the instrument (average values for each time interval in question):

PHASE	CPM (counts per minutes)
0	16 ± 2
1	15 ± 2
2	16 ± 2
3	15 ± 2
4	14 ± 2
5	16 ± 2

Table 5: Count per minute values for each test phase as described in Table 1 (Please note that Phase 0 correspond to the background value)

CONCLUSIONS

From the measures it is shown that there are no evidence, within the bounds of the instruments presented before, of meaningful differences in the measured values compared to the background environmental radiation.

Further:

- The absence of neutron field observable from the measured background does not allow the dosimetric analysis for a comparison with the calibration values associated with the instrument.
- The measure results are not dissimilar from the environmental background both as average and as maximum values.

In faith
Dott. Bianchini David

On the γ radiation measurements on the Rossi system

Mauro Villa,
Bologna University and INFN Sezione di Bologna

January 26, 2011

Abstract

We report here on the measurement of γ emission from the system built by Rossi et al. to produce energy. While the details of the production system are still not known, an international patent request (WO/2009/125444) and a paper describing the main characteristics and performances are available: copper synthesis starting from an hydrogenated nickel compound and energy production lasting for monthes. On the 14th of January 2011, the first public test of this system was performed under partially controlled conditions. Since the interpretation proposed by the authors for the energy production and for the copper synthesis are the chain reactions involving ${}^X-1Ni + p \rightarrow {}^XCu + Q$ (fusion), ${}^XCu \rightarrow {}^X Ni + e^+ + \nu + Q$ (β^+ decay) and ${}^XCu + e^- \rightarrow {}^XNi + \nu + Q$ (electron capture) the system internal should produce a significant amount of γ radiation produced directly or through the annihilation reaction $e^+e^- \rightarrow \gamma\gamma$. The energy power input and output and gamma radiations were measured before, during and after the active phase of the system, as well as the hydrogen consumption. While a net energy output was observed, no γ excess (with energy above $200keV$) has been measured above the natural background level ($< 180 Hz$ rate in single mode, compared to an expected rate largely in excess of $1 MHz$). The theoretical interpretation of the effect mentioned in the patent filed and in the paper seems to be therefore not adequate. Moreover, the short duration of the preliminary test (45 minutes) and the test conditions, suggest therefore to conduct accurate and long measurements before drawing any conclusion on the nature of the energy production process.

1 Introduction

1.1 Patent claims and theoretical interpretation

The international patent request WO/2009/125444 [1] describes a remarkably simple system able to produce heat. The basic building blocks are: 1) a tube (reaction chamber) containing nickel powder and other elements (reaction catalyzers) filled with hydrogen gas, 2) several resistors used to heat the chamber and 3) a cooling system where liquid water is flown in and water steam is obtained in output. The main patent claim is on "a method and apparatus for carrying out highly efficient exothermal reaction between nickel and hydrogen atoms". In the description of the patent, it is mentioned that only during the initial phase (lasting up to 3-4 hours) an electric resistor is needed to bring the reactor up to the working point; afterwards the resistor can be switched off and the system can be self-sustained, producing more energy than that initially required.

Although unsure and only hypothetical, a possible interpretation for the energy production, mentioned in the patent request, are the nuclear reaction chains ${}^{X-1}\text{Ni} + p \rightarrow {}^X\text{Cu} + Q$ (copper production) and ${}^X\text{Cu} \rightarrow {}^X\text{Ni} + e^+ + \nu + Q$ (copper β^+ decay) or ${}^X\text{Cu} + e^- \rightarrow {}^X\text{Ni} + \nu + Q$ (electron capture). Starting from stable nickel nuclei, the mentioned reactions should lead finally to stable copper nuclei: ${}^{63}\text{Cu}$ and ${}^{65}\text{Cu}$. Two arguments are presented in favor of this interpretation:

- given the small amount of nickel powder involved, the large energy production seems not to be compatible with a chemical origin;
- the post-reaction analysis of the powder shows nuclei not present before reaction.

In addition to the patent request content, a paper [2] published on web provides more quantitative information: the power production can last for months and the isotopic composition of copper nuclei in the powder changes from a ratio of ${}^{63}\text{Cu}/{}^{65}\text{Cu}=2.24$ (natural composition) to 1.6 after heat production (statistical and systematic uncertainties are not quoted). For these (and other) reasons, the authors claimed to have found a "unique system ... able to obtain energy from nuclear fusion reactions", despite the fact that no nuclear activity has been measured during reactor functioning (outside shielding).

2 Preliminary considerations

This patent request and the related article rose a lot of interest in the nuclear physics community. Since the new method and the new concept of nuclear reactions (labelled elsewhere as "Low Energy Nuclear Reactions", LENR) challenge the basis of the nuclear physics field, a deep independent investigation is needed to confirm these findings. As a general rule, *the more extraordinary the scientific claims are, as in this case, the deeper should be the investigation* to rule out common and quite well known effects.

In the first public demonstration of the reactor, we were allowed to perform measurements before, during and after reaction functioning. Even if the measurements were severely limited by the non disclosure of the reaction chamber and of the associated electronics, nevertheless some important aspects have been tested:

- Energy production. To test the claim of non-chemical origin of the energy produced, the measure of the output-input power difference integrated times the measuring time (i.e. the total energy produced) is needed and should be compared with the mass and size of the energy source. For example 1 MWh produced by 1 g of material is a good indication of a nuclear origin, while 5 Wh produced by 30 g of material is an indication of chemical origin. In the present test, as a precautionary attitude, whatever was not known, not disclosed or not understood has been considered as the energy source. This forces to consider relevant only very large energy productions, as those described in [1] where the reactor has been working for weeks and monthes.
- Radiation detection. To test the theoretical interpretation of the energy production a *doubtless conclusion* would be to identify signatures of nuclear reactions. Since, to our knowledge, there is no nuclear transmutation reaction chain that proceeds without producing gammas (sooner or later), the radiation detectors can be used to search any other (less direct) sign of nuclear activity, such as gammas of any origin, providing support for the nuclear interpretation of the energy released. In [2], a value of 35 MeV is evaluated as a mean energy production for Ni nuclei starting the reaction chain, part of it necessary released as direct γ . The *clearest signature* is however the identification of two 511 keV γ from e^+e^- annihilation, which would follow any β^+ decay of copper nuclei. This is actually a clean signature since: 1) it requires two *simultaneously* signals in two different detectors, 2) characteristic topology (back-to-back) of the γ (to be matched with



Figure 1: A photo of the apparatus. One scintillator detector is pointing upwards and is visible in the center of the picture, while the other is partially covered in the back.

the detector placement) and 3) the annihilation rate should follow the power production: zero before reactor starting, increase (or flat top) during functioning and decrease after reactor switching off. These three independent indications (if coherent) would provide a strong support of the claimed effects and their theoretical interpretation.

3 Experimental set-up

The experimental set-up is shown in fig 1. The basic observable elements are an horizontal metallic tube (approximate length 70 cm, diameter 20 cm, 22 l

volume, 30 kg weight as a guess-estimate) as the reaction chamber, a vertical tube for steam output (50 cm length, 15 cm diameter, 9 l volume), a control system box (approx 40x40x40 cm^3 dimensions, 64 l volume, unknown weight), a water pump and an hydrogen bottle. In the patent request [1] and in the paper [2] the horizontal tube is described as containing a reaction chamber where a nickel powder, catalyzers and the H_2 react to provide energy. In order to start the energy production the system should be operated at high temperature, therefore electric resistors are used for initial heating. An heat sink composed by a flowing water transforming into steam is used to draw the heat from the tube internal. An external shielding (thickness unknown) covers all the details to the external observer. The vertical tube is used for dry steam production. The control system box is practically the only element receiving electrical power from outside, and drives the resistors with 5 double-wire electrical cables. A pump provided a stable liquid water flow in the inside of the horizontal tube system and an hydrogen bottle was connected to the reaction chamber.

Several parameters were controlled during the tests:

- the input electrical power was measured on a power meter and recorded every 8 seconds;
- the environment temperature, the input water temperature, the output water steam temperature were logged every 2 seconds;
- the vapor quality was measured online;
- the water flux was measured at the beginning and assumed constant;
- gamma production from the system was monitored with NaI counters (main subject of this report);
- the environmental radiation was measured online (described in [3]).

No flux measurement has been done on the output steam flow. Temperature parameters and input-output power measurements are described in detail in [4].

4 Gamma detection set-up and preliminary control measurements

The measurements of the γ radiation was performed with two identical NaI(Tl) scintillators. The active volume is a cylinder of 3 inch diameter

and 3 inch height. Before installation in the set-up the two detectors were calibrated, equalized (at about 13% level) and longly tested (2 monthes). In fig. 2, a typical signal from scintillators is shown (left), together with a spectrum obtained with a ^{22}Na source. In the spectrum, clear signals standing at ≈ 3400 ADC channels and 8200 ADC channels are visible, which correspond respectively to the 511 keV gammas from e^+e^- annihilation and γ with energy of 1.275 MeV from ^{22}Na . In table 1 the energy resolutions as measured on a ^{22}Na source are shown. During these long tests, the scintillators draw stable currents and provided signals quite stable in amplitude (5% tolerance). No indication of instability of any kind was observed.

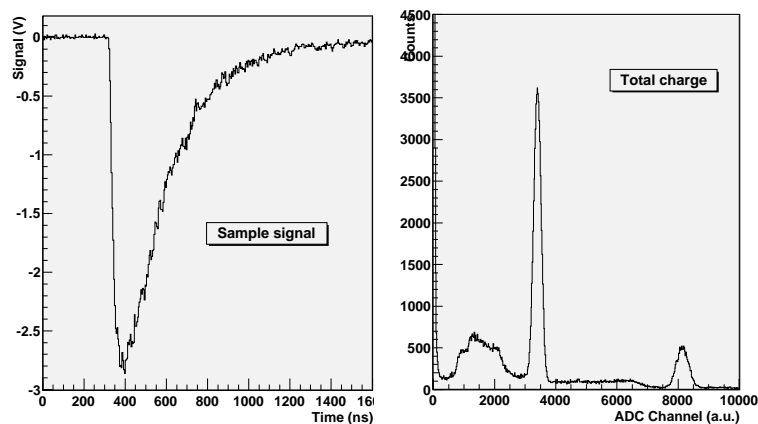

Figure 2: Left: a typical signal from NaI exposed to a ^{22}Na source taken at the lab. Right: spectrum of ^{22}Na signals; the peak at ≈ 3400 ADC counts is the 511 keV signal and that at ≈ 8200 is the 1.275 MeV γ line.

In the system test, the two scintillators (labelled A and B) were fixed to the tube (fig. 1) in correspondence of two holes performed in the shielding. Despite the request of having two holes back-to-back of 1 mm diameter; two holes of more than 1 cm diameter were prepared. No detail of the system internal was given, nor the explicit position of the energy source. The placement of the holes and of the scintillators corresponded approximately to the hottest region of the horizontal tube. Following an explicit request by Rossi, only counting measurements were performed, the energy spectra being considered an industrial secret.

The electronics used in the tests were a digital oscilloscope and a NIM crate holding the following modules: a 4 channel high voltage generator (Caen NIM 470), a 6 channel amplifier for analog signals (Le Croy 612), an

Table 1: Raw γ line positions and resolutions of the NaI(Tl) scintillators

Source	γ energy (MeV)	Scintil- lator	Line position (adc counts)	line width (adc counts)	resolution (%)
^{22}Na	0.511	A	3400.4 ± 0.6	124.1 ± 0.7	3.6%
^{22}Na	0.511	B	3060.8 ± 0.5	99.0 ± 0.6	3.2%

8 channel discriminator (Caen 96), a coincidence unit (LRS 465), a Logic Fan In Fan out (Caen 429A), a 4 channel scaler (Caen 145), two Dual Timers (Caen N93B and N2255B). The PMT of the two scintillators were powered at 850 V (scintillator A) and 750 V (scintillator B). The current drawn at the beginning of the tests were respectively $597 \mu\text{A}$ and $521 \mu\text{A}$, values in agreement with what observed in the preparatory phase. Signals from the two NaI(Tl) scintillators travelled on 16 ns lemo cable towards the oscilloscope configured in high impedance mode for signal monitoring and were forwarded (on 16 ns lemo cables) to the amplifier module. The amplified (gain 20) signals were first discriminated with thresholds of -254 mV and -255 mV respectively. The thresholds were set at about 40% of a typical full-energy signal from a 511 keV gamma, therefore corresponds to a threshold of 200 keV in the γ energy. The discriminated signals were plugged directly to the scalers for single counting measurements (labelled counters "A" and "B" in the following) and the logic coincidence (AND gate) of the A and B signal was connected to a third scaler, labelled "A&B" in the following. Signal "A" was also delayed by $1 \mu\text{s}$ and put in coincidence with signal B; this coincidence was counted by a fourth scaler, labelled "(DelayedA)&B". The "A" and "B" scalers provide information on single counting rates, i.e. single gammas of energy above 200 keV coming from the system or from background. The "A&B" scaler would provide the fingerprint of the annihilation reaction $e^+e^- \rightarrow \gamma\gamma$ following a β^+ decay occurring in the system chamber (from any nuclei). The "(DelayedA)&B" scaler provides a measurement of the accidentals (random coincidences) of signals from the two scintillators.

Before the measurements, the electronics was calibrated with a ^{22}Na source. Although data were not recorded, the proper settings of the single gamma scalers and of the coincidence "A&B" was demonstrated by repeatedly placing and removing the source from the two facing scintillators. All counters behave repeatedly in an understandable way: high countings with the source placed between the scintillators, background countings when the source was removed. Before switching on the system, the electronic set-up

Table 2: Timetable and phases of the preliminary test on the 14th January 2011. Main phases: 0- initial conditions, 4 system working, 9 - final conditions.

time	Status or operations performed	phase
11:00-13:30	Installation of the set-up and preliminary checks	-
15:17	Turning on of the γ measurement set-up.	0
	First background measurements	0
	Resistors are switched off; H_2 bottle closed	0
16:23	Switching on of the resistors	1
16:23-16:31	Resistors connected to power; H_2 closed	2
16:31	Opening of the H_2 bottle	3
16:31-17:16	Resistors powered; H_2 opened	4
16:35	Power cut (about 1 min)	5
17:16	Closing of the H_2 bottle	6
17:16-17:19	Resistors powered; H_2 closed	7
17:19	Switching off the power to the resistors	8
17:19-17:42	Resistors unpowered; H_2 closed	9

was re-checked. Simple tests of the coincidence scaler were performed with cosmic rays before final scintillator fixing on the reactor shielding.

The proper functioning (and stability) of all the system detecting γ s has been rechecked after the system test.

5 The γ rate measurements

The exact timing and sequence of the operations performed are shown in table 2. From 15:17 to 17:42 (145 minutes) the scalers associated to gamma counters were checked, video taped and recorded on-line by hand. Only those recorded by hand are presented here (70 data points) and shown in fig. 3. As can be seen all counters and the dynodic currents show a stable behaviour. It is interesting to remark that without additional information it is not possible to identify the the data points recorded during power generation. A clear deviation from the stability would have showed a *direct evidence* of gamma production, as the temperature measurements do for the energy production discussed in [4]. *Only by looking at the last plot in the picture*, it is possible identify the measurements 44-61 (from 16:31 to 17:16, 45 minutes) as those recorded with resistors switched on and the H_2 bottle opened, which by the way was also the period where energy was

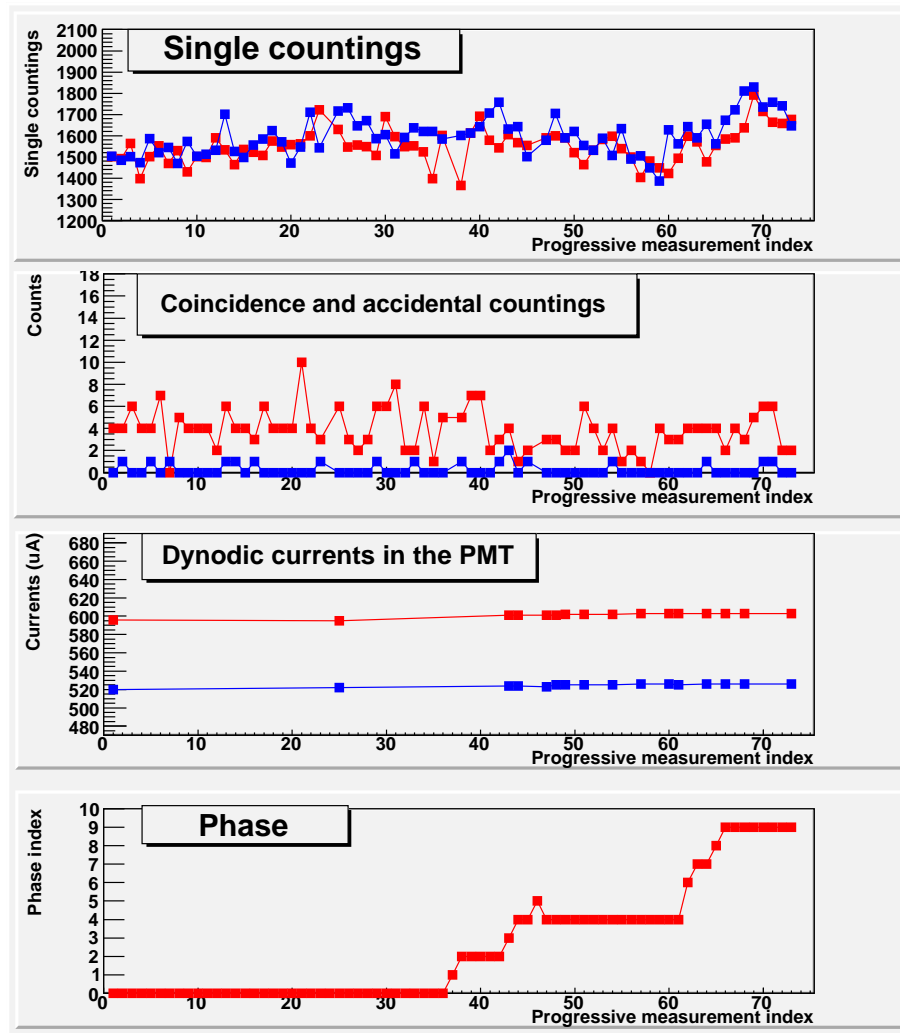

Figure 3: Radiation measurements before, during and after system functioning. On top the single countings "A" (red) and "B" (blue) measured every 10 seconds, followed by the on time-coincidence ("A&B", red) and accidentals ("DelayedA)&B", blue). Further down there is the dynodic current drawn by the PMT bases (A, red and B, blue) of the two scintillation detectors and at the bottom there is the experimental status as coded in table 2.

produced. The lack of this indication in the upper part of the picture is a visual indication that no gamma excess was actually recorded from the

Table 3: Rates measured in the three key periods: before turning on (phase 0), during working conditions (phase 4), at the end of the test (phase 9).

Phase	Counter A (Hz)	Counter B (Hz)	Counter "A&B" (Hz)	Counter Delayed(A)&B"
0	153.7 ± 1.2	157.3 ± 1.3	4.3 ± 0.3	0.3 ± 0.1
4	152.2 ± 1.5	155.7 ± 1.9	2.5 ± 0.4	0.1 ± 0.1
9	166.4 ± 2.4	173.9 ± 2.2	3.8 ± 0.6	0.3 ± 0.2

apparatus. A numerical analysis confirmed these findings.

Table 3 contains the numerical information for the counting rates for the three key periods: before turning on (phase 0), in working conditions (resistors switched on and H_2 bottle opened, phase 4) and at the end of the test (phase 9). During phase 4 the external temperature of the system rose significantly [4] and we have to assume that the scintillators might have experienced a temperature increase as well, being almost in thermic contact with it. Also in phase 9 the reactor shielding was hot (temperature not monitored).

In table 4 the single rates measured during phase 4 and 9 are compared to those measured in phase 0. A simple significance parameter, defined as the rate excess (or defect) divided by its uncertainty is presented close to the rate excesses (or defects). As can be seen, while during phase 4 no excess has been recorded (all significances within a 3σ level), for phase 9 single counters deviates up to 6.6σ . In table 5 the same comparison is presented for the

Table 4: Excess of single counting rates in phases 4 and 9 with respect to phase 0.

Phase comp.	Counter A		Counter B	
	Rate diff (Hz)	significance	Rate diff (Hz)	significance
4-0	-1.4 ± 1.9	-0.74σ	-1.6 ± 2.3	-0.67σ
9-0	12.7 ± 2.6	4.8σ	16.7 ± 2.5	6.6σ

Table 5: Excess of coincidence and accidental counting rates in phases 4 and 9 with respect to phase 0.

Phase comp.	Counter "A&B"		Counter "Delayed(A)&B"	
	Rate diff (Hz)	significance	Rate diff (Hz)	significance
4-0	-0.17 ± 0.05	-3.5σ	-0.015 ± 0.013	-1.33σ
9-0	-0.05 ± 0.07	-0.73σ	0.00 ± 0.02	0.08σ

coincidence (A&B) and accidental (Delayed(A)&B) countings. Coincidences show only negative significances, with an lower value of -3.5σ . Accidentals are compatible with no effects: all values below (3σ) .

There are 3 measurements above the 3σ limit (two excesses and one lack of γ s); a measurement above the 5σ (excess) and no 8σ effects. Since: 1) the measurement above the 5σ has been taken with the reactor switched off; 2) the other 7 values are not always confirming this behavior (excesses and lacks of γ s); 3) the effect of the temperature on our scintillators are unknown and 4) radon contamination was not measured, by the precautionary principle *it is safe not to consider significant this single excess*. A possible explanation of the excess seen at the end of the tests concerns radon. Tap water was used and transformed to steam (order of 7 liters/s of water steam diffused in a room near the apparatus. It is well known that in this process radon gas is released in the environment. Gamma radiative decays of radon or other instable nuclei in the radon decay chain could not be excluded and might be the source of the delayed increase of environment radioactivity. More, long and accurate measurements should be performed in order to keep track of these possible contaminants.

An $8\text{-}\sigma$ criterion would have required to measure in any of the several 10 s periods rates above these limits: $> 185\text{Hz}$ (counter A), $> 189\text{Hz}$ (counter B) and $> 21\text{Hz}$ (coincidence). These values can be considered as a threshold for effect confirmation. No data value, fulfilling this criterion, is present in the test. By the quoted numbers, it is possible to evaluate the sensitivity of the γ detection system: $\approx 30\text{ Hz}$ in single counting mode or $\approx 17\text{ Hz}$ in coincidence mode for signals above the background in a counting period of 10 s.

6 Discussion

The energy measurements provided the following results, which are summarized in [4]: electrical power in input of about 1 kW; energy power in output about 12.7 kW for a time period of about 40 minutes. Assuming that the observed energy excess production rate ($\approx 11\text{ kW}$) is coming from nuclear reaction, knowing that a typical energy release is of the order of 1 MeV, it is possible to estimate the total fusion rate to be of the order of $7 \cdot 10^{16}$ reaction/s (fusions or decays). Assuming that the reactions are distributed along the hottest part of tube (30 cm length, where the detectors have been placed), taking into account the solid angle seen by the two NaI detectors through the two 1 cm diameter holes in the shielding ($\approx 2.5 \cdot 10^{-3}$

steradians), a total rate largely in excess of 10^{11} γ /s can be estimated to be emitted within the solid angle seen by the two detectors.

This rate is so huge that there is no possibility for it to escape detection provided that the γ have an energy above the 200 keV threshold. Notwithstanding the uncertainties of the energies of the gamma produced (511 keV and >1 MeV are just guesses) and the details of the shieldings, the energy range (0.2-4 MeV) is well known to be difficult for gamma containment. In this region, in fact, for several materials, the dominant γ interaction is compton scattering, an elastic process that changes the γ energy, but not the γ counting in a relevant manner. Even assuming that the whole horizontal tube is made of lead (10 cm radius), we expected some γ to pass. In laboratory, in fact, the absorption of gammas from ^{22}Na (a β^+ emitter, releasing 511 keV and 1.275 MeV gammas) from different thickness of lead has been measured with the same set-up and thresholds as those used in the system test: 5 cm of lead are enough to reduce the unshielded flux to $\approx 5.7\%$, while 10 cm of lead reduced the unshielded flux to $\approx 0.5\%$ (single countings). Taking into account these numbers, one can easily conclude that the observed γ rates are incompatible with the expected ones (at least by 6 orders of magnitude). *This seems to rule out the explanation proposed for the energy release* (production of copper nuclei via reaction chains involving β^+ decays).

7 Conclusions

The main findings of the present study are the following:

- the present reactor was actually able to vaporize a cold liquid water flux for about 40 minutes, showing a sizeable output-input power difference and an integrated power production of several kWh [4];
- no gamma radiation above the background level in the energy region $E_\gamma > 200 \text{ keV}$ has been observed, neither in single counting, not in coincidence;
- regardless of the internal details of the reaction chamber, shieldings and other industrial secrets, the γ rates measured with the NaI counters seem not compatible with the rates deduced or expected assuming that the energy production was due to nuclear fusion or decay reactions, as suggested in [1].

Thus at present having found no nuclear reaction fingerprints, further investigations are indeed needed to identify the energy production process.

We are opened to collaborations with the proponents to complete the tests by covering also the low energy gamma region ($20 - 200 \text{ keV}$), to measure possibly slow or fast neutron emissions and to perform measurements on long runs. The duration of the tests would be directly proportional to the mass and volume of unknown origin. For the present set-up a convincing evidence would include a power production of (order of) 10 kW sustained for weeks in a controlled and monitored environment.

Acknowledgements

The author wishes to thank Ing. Rossi and Prof. Focardi for letting these measurements to take place and all the people involved for their cooperation.

Disclaimer

The present report concerns mainly the radiation measurements to confirm or disprove the nuclear interpretation of the energy release. Very clean and undoubted signals were looked for. Measurement conditions were not ideal in few cases (weighing procedures, duration, systematics, fluxes) and needs to be redone properly.

References

- [1] A. Rossi (inventor), *Method and Apparatus for Carrying out Nickel and Hydrogen Exothermic Reactions*, (WO/2009/125444) <http://www.wipo.int/pctdb/en/wo.jsp?WO=2009125444>;
- [2] S. Focardi and A. Rossi, *A new energy source from nuclear fusion*, Journal of Nuclear Physics, <http://www.journal-of-nuclear-physics.com/?p=66>, February 2010;
- [3] D. Bianchini, *Experimental evaluation, for radiation protection purpose, of photon and neutron radiation field during the public presentation of the prototype called "Energy Amplifier"*. <http://www.journal-of-nuclear-physics.com>
- [4] G. Levi, *Report on heat production during preliminary tests on the Rossi "Ni-H" reactor*, <http://www.journal-of-nuclear-physics.com>.