

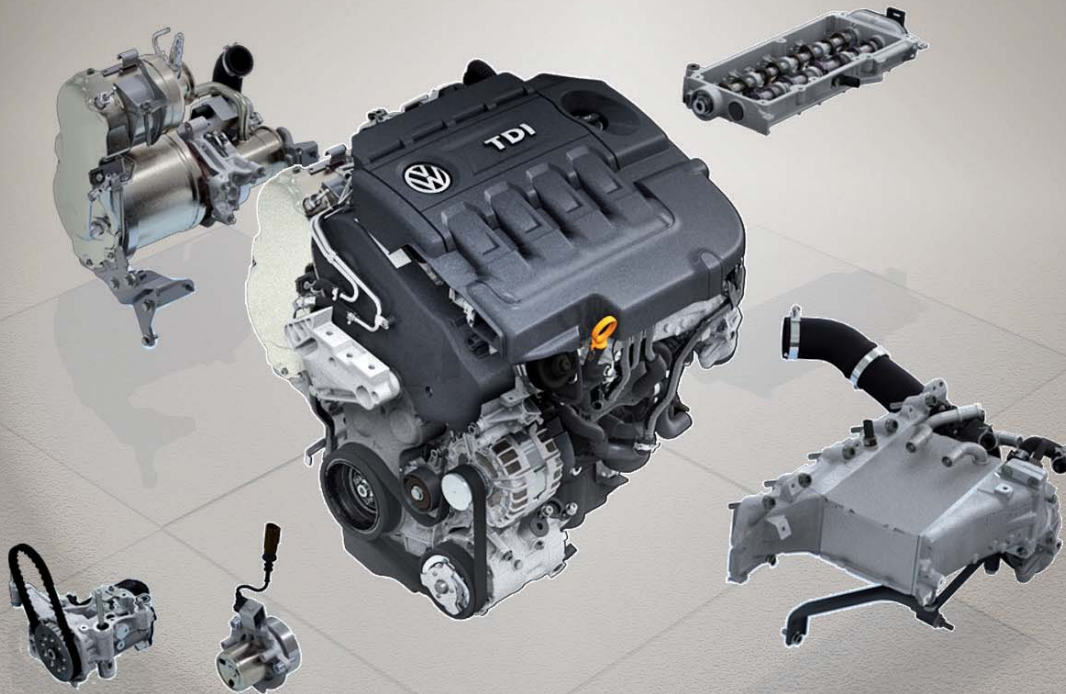

Self Study Program 820433

The EA288 Diesel Engine Family

Design and Function



Volkswagen Group of America, Inc.
Volkswagen Academy
Printed in U.S.A.
Printed 2/2014

Course Number SSP 820433

©2014 Volkswagen Group of America, Inc.

All rights reserved. All information contained in this manual is based on the latest information available at the time of printing and is subject to the copyright and other intellectual property rights of Volkswagen Group of America, Inc., its affiliated companies and its licensors. All rights are reserved to make changes at any time without notice. No part of this document may be reproduced, stored in a retrieval system, or transmitted in any form or by any means, electronic, mechanical, photocopying, recording or otherwise, nor may these materials be modified or reposted to other sites without the prior expressed written permission of the publisher.

All requests for permission to copy and redistribute information should be referred to Volkswagen Group of America, Inc.

Always check Technical Bulletins and the latest electronic repair information for information that may supersede any information included in this booklet.

Trademarks: All brand names and product names used in this manual are trade names, service marks, trademarks, or registered trademarks; and are the property of their respective owners.

Contents

Introduction	1
Engine Mechanics	4
Engine Management System	40
Service	67
Knowledge Assessment	71

This Self-Study Program provides information regarding the design and function of new models. This Self-Study Program is not a Repair Manual. This information will not be updated.

For maintenance and repair procedures, always refer to the latest electronic service information.

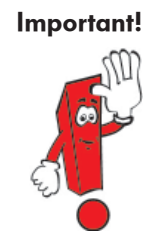
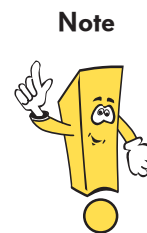



Page intentionally left blank

EA288 Diesel Engine Family

Volkswagen is introducing a new family of diesel engines in the 2015 Golf. The engine family has the designation EA288 (EA = Entwicklungsauftrag [development order]).

The design of this new generation of diesel engines was based on the existing EA189 engine family. Displacement, cylinder spacing, stroke and bore ratio are shared between the EA189 and the new EA288 gasoline engines. The new EA288 engine design forms the basis for all future inline diesel engines at Volkswagen.

Several sub-assemblies were redesigned in the EA 288 family of 4-cylinder diesel engines to satisfy future emission standards.

In this Self-Study Program you will learn about the structure and design of the new EA288 TDI engine, and the functions of the individual engine subsystems.



Introduction

Modular Diesel Matrix (MDB)

The new EA288 diesel engine family is also called a modular diesel matrix, or MDB. The modular diesel system is the basis for all future inline diesel engines in the Volkswagen Group.

The modular diesel matrix is a concept that involves dividing the functional engine components into modules. Depending on capacity, power output, emission standard and the vehicle class, engines can be assembled from modules and components.

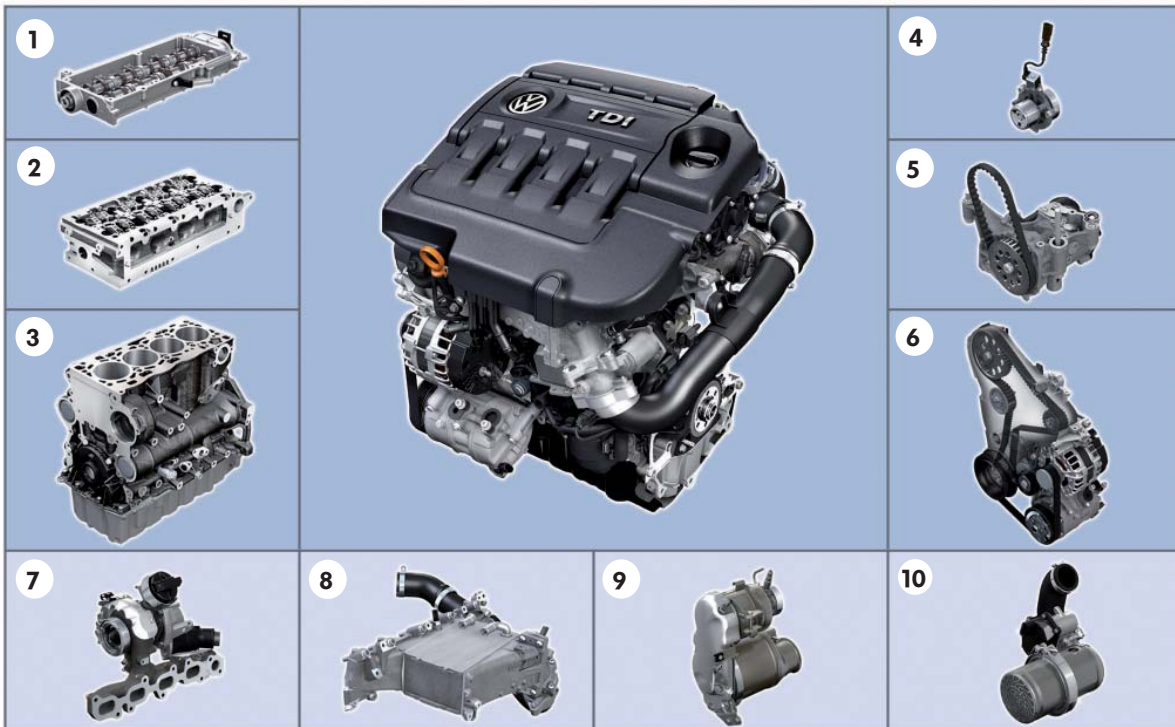

S514_104

Basic Engine	
1	Modular Camshaft Housing
2	Cylinder Head
3	Cylinder Block
4	Switchable Coolant Pump
5	Oil/Vacuum Pump
6	Timing Drive and Accessory Drive

Attachment Parts	
7	Exhaust Manifold Module with Turbocharger
8	Intake Manifold with Water-Cooled Charge Air Cooler
9	Exhaust Purification Module
10	Exhaust Gas Recirculation Module

The modular design meets fuel consumption, exhaust emissions and power delivery demands. It also allows the engines to accept future modular components that meet upcoming country-specific requirements with minimal costs.

Technical Data

Engine Code	CRBC
Design	Four-cylinder inline engine
Engine Capacity	1968 cm ³
Bore	81.0 mm
Stroke	95.5 mm
Valves per Cylinder	4
Compression Ratio	16.2:1
Maximum Output	150 hp (110 kW) from 3500 to 4000 rpm
Maximum Torque	235 lb/ft (320 Nm) from 1750 to 3000 rpm
Engine Management System	Bosch EDC 17
Fuel	Ultra-Low Sulfur Diesel
Exhaust Gas Aftertreatment	Exhaust gas recirculation, oxidizing catalytic converter, diesel particulate filter
Emissions Standard	BIN 5

Torque and Power Diagram

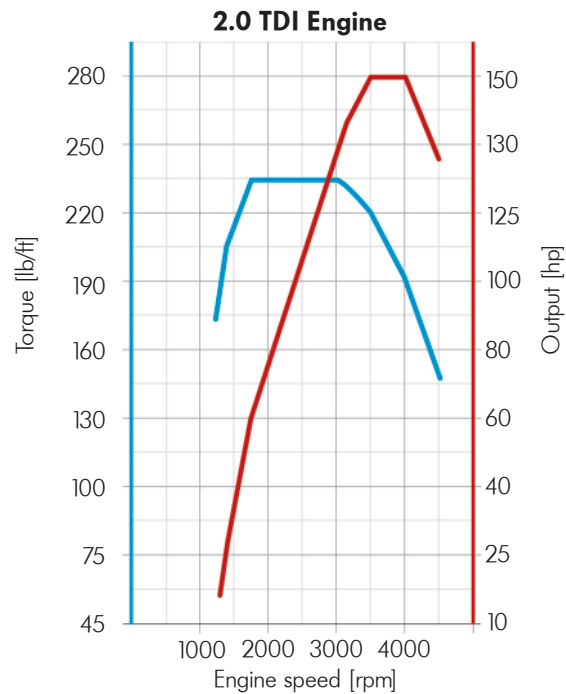

SS14_100

Engine Mechanics

Cylinder Block

The EA288 cylinder block is grey cast iron, an alloy of cast iron and flake graphite.

The cylinder block has deep screw threads for long cylinder head bolts. This distributes combustion forces through the cylinder-block structure, applying equal pressure distribution on the cylinder head gasket.

The design of the cooling channels in the cylinder block provides good cooling in the area between the cylinders.

Cylinder Block 2.0L TDI Engine

The cylinder block for the 2.0L TDI engine is available for engines with and without balance shafts.



Crankshaft Group

Crankshaft

The EA288 engine uses a forged crankshaft with five bearings to distribute the high mechanical loads. Instead of the usual eight counterweights, this crankshaft only has four counterweights to counteract the rotating forces of inertia.

This design reduces the load on the crankshaft bearings. Noise emissions, which may be caused by inherent movement and vibrations in the engine, have also been reduced.

The toothed belt sprocket that drives the oil pump and the sprocket that drives the balance shafts are an interference fit onto the crankshaft.

Piston and Conrod

The pistons in the EA288 engine have no valve pockets. Instead, the dish design of the piston crown reduces dead space and improves the swirl formation of the intake air in the cylinder.

To improve piston ring area cooling, the pistons have a ring-shaped cooling channel into which oil is sprayed via piston spray nozzles.

The conrods are cracked trapezoidal conrods.

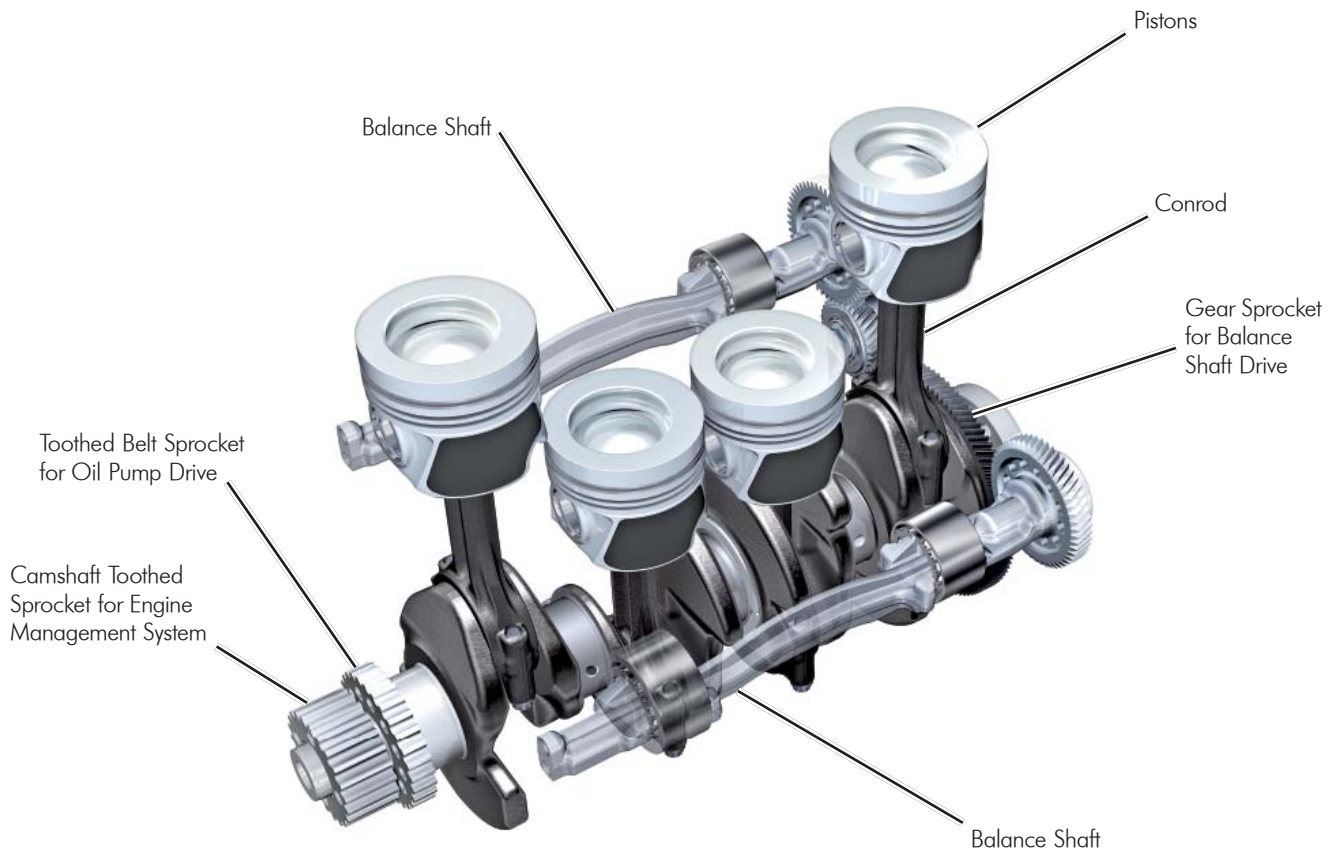

Engine Mechanics

Balance Shafts

One version of the 2.0L TDI engine has a balance shaft system to reduce crankshaft inertial forces inherent in a straight four-cylinder engine. The balance shaft system has two countershafts rotating in opposite directions at double the speed of the crankshaft.

Function

The balance shafts are driven by a gear wheel drive connected to the crankshaft. An idler gear between the crankshaft and one of the balance shafts reverses the direction of the second balance shaft. Both balance shafts and the idler gear are axially and radially mounted with roller bearings in the cylinder block to reduce friction.



S514_007

The roller bearings are lubricated by oil mist in the cylinder block.



The components in the balance shaft system cannot be replaced in the field because the play between the gears cannot be adjusted using workshop tools.

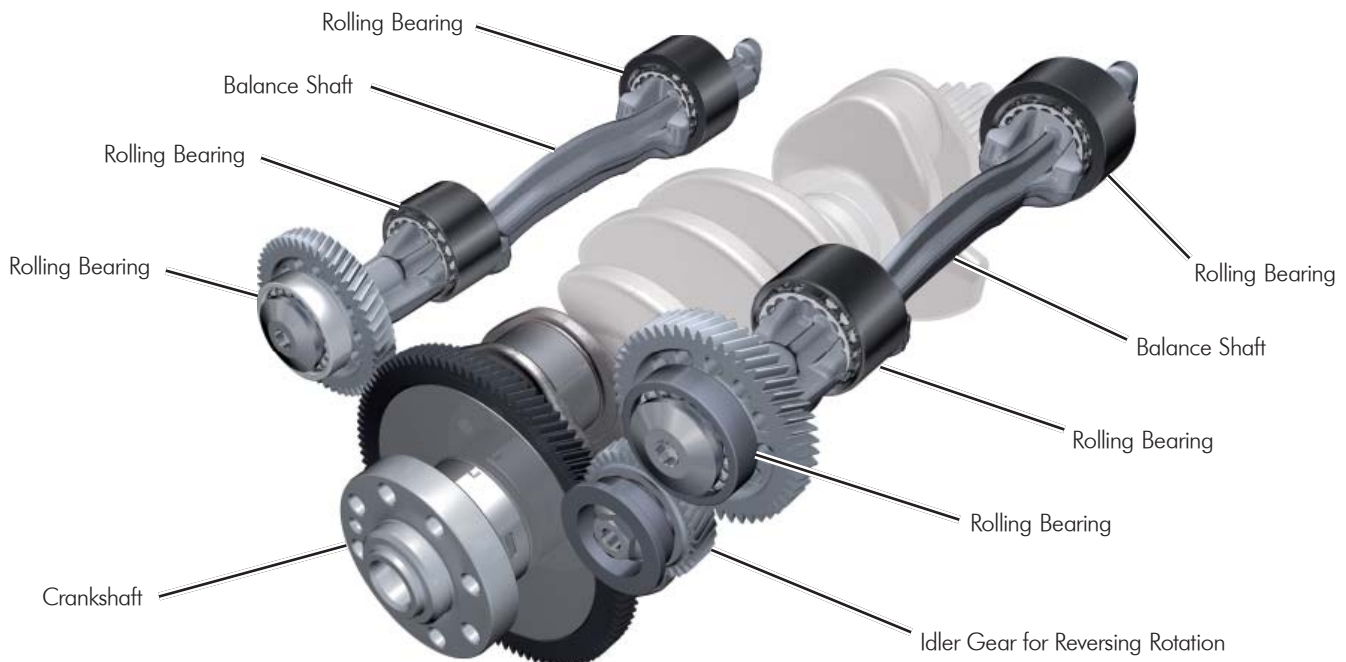

S514_016

Toothed Belt Drive

The engine timing components are driven by the crankshaft via a toothed belt. From the crankshaft, the toothed belt is routed to the belt tensioner, over the camshaft drive wheel, to the drive wheel of the high-pressure pump for the common rail injection system, and then to the drive wheel of the coolant pump. Two idler rollers ensure better meshing of the gear wheels and the toothed belt.

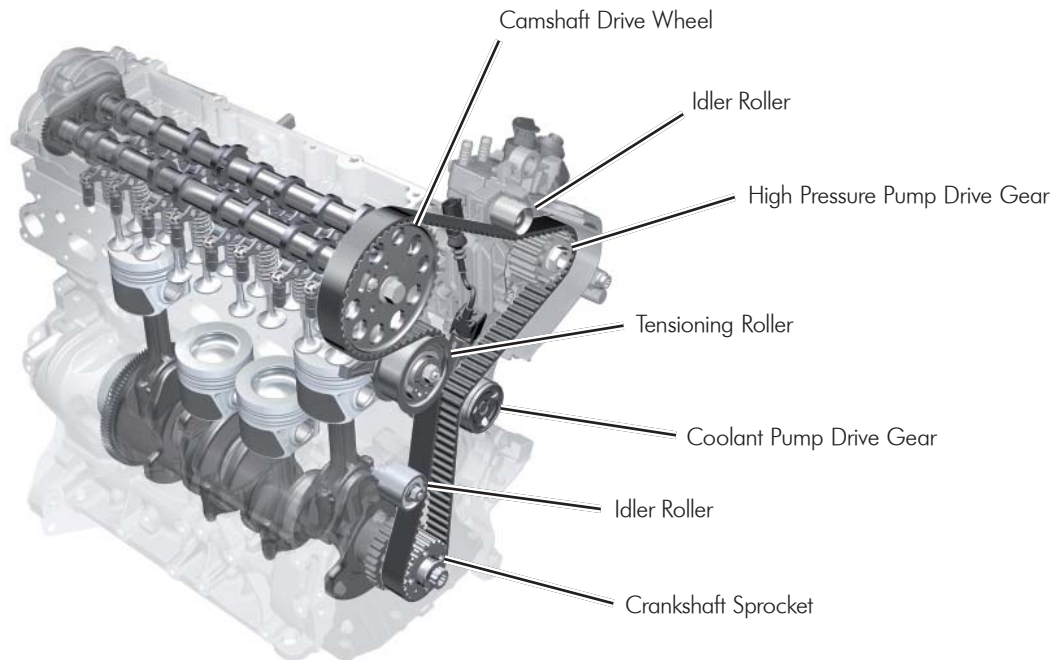

S514_041

Accessory Component Drive

The alternator and the air conditioner compressor are driven by the crankshaft by a pulley with vibration damper and a poly V-belt. The poly V-belt is tensioned by a spring-loaded belt tensioner.

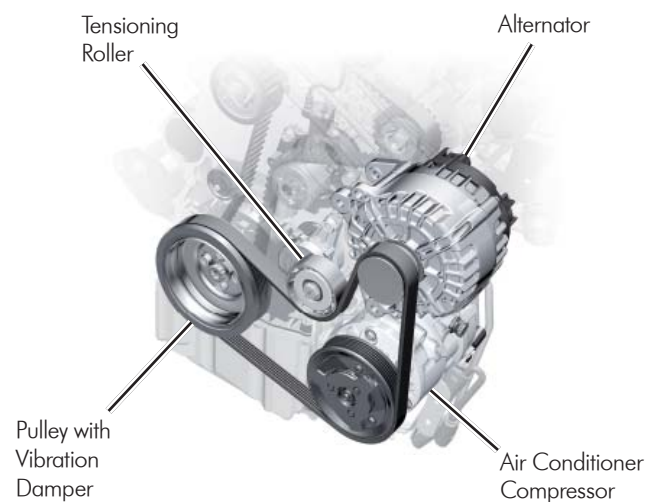

S514_008

Engine Mechanics

Cylinder Head

The aluminum alloy cylinder head of the EA288 engine has a cross-flow design and a unique placement of intake and exhaust valves. The valves are operated by two camshafts.

Because of the arrangement of the intake and exhaust ports, each camshaft operates intake and exhaust valves. There is not a separate intake or exhaust camshaft.

The camshafts are driven by the crankshaft by a toothed belt and the camshaft gear of one of the camshafts. The two camshafts are joined by a spur gear.

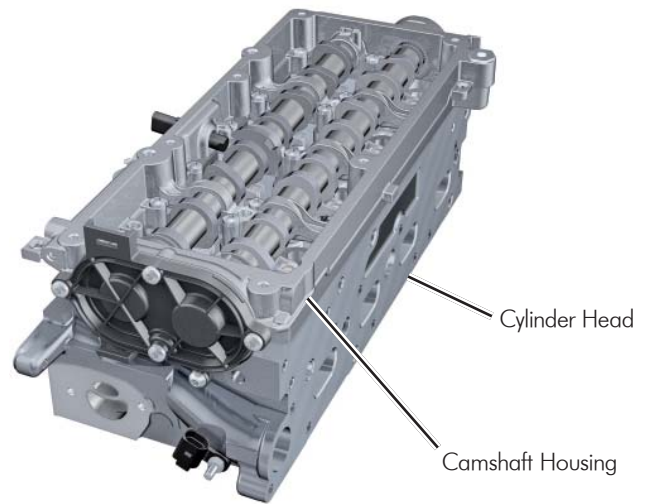

S514_042

Camshaft Housing

The camshafts are integrated into a closed retaining frame by a thermal joining process. They cannot be separated. This process ensures a very rigid camshaft bearing while keeping the weight low.

To reduce friction, a needle bearing is used for the first bearing that receives the highest forces from the toothed belt drive. A sensor wheel for G40 Camshaft Position Sensor is located on one camshaft. The signal from the Hall sensor tells the ECM the current position of the camshafts.

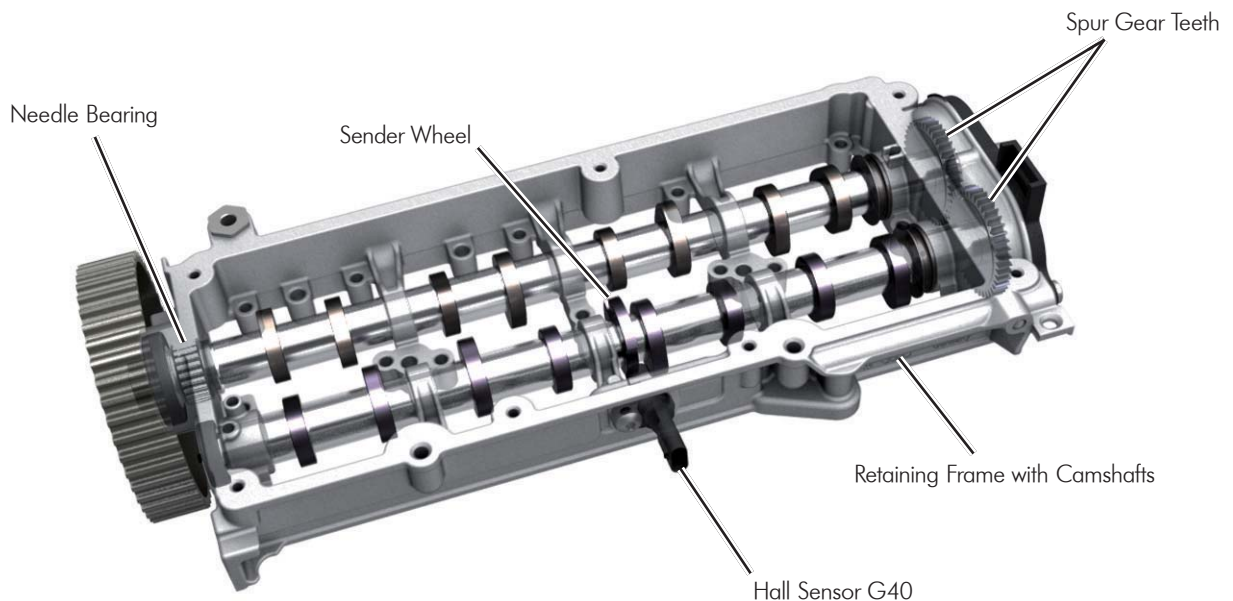

S514_043



The camshafts cannot be removed from the camshaft housing. If there is damage to the camshafts or the housing, the complete assembly must be replaced.

Valve Layout

For future emission standards, the 'valve star' has been rotated to the longitudinal axis of the engine. This means the intake and exhaust ports for each cylinder are positioned one behind the other in the direction of flow. As a result, each camshaft actuates one intake and exhaust valve per cylinder. The valve layout has been designed to allow maximum air delivery with good swirl effects.

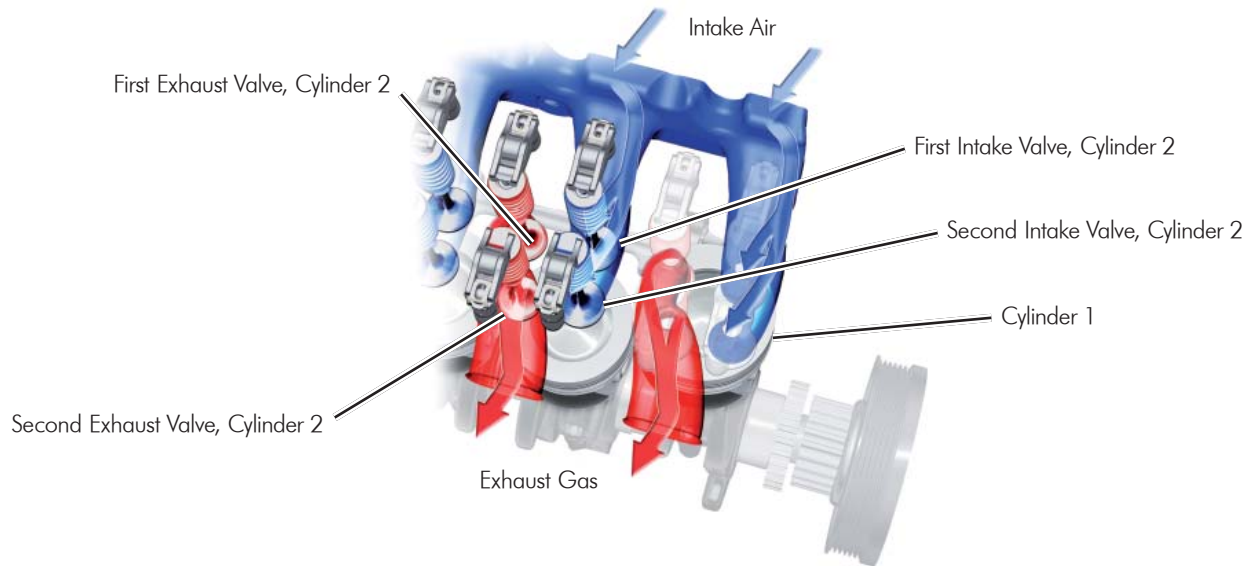

S514_059

Coolant Jacket

The cylinder head has an upper and lower coolant jacket. The lower coolant jacket core has a larger volume, to provide a high level of heat dissipation in the part of the cylinder head close to the combustion chamber. The flow of coolant from the upper and lower parts merge at the spur gear side of the cylinder head where it exits through a combined outlet.

To provide heat when the engine is cold, the coolant is channeled out of the upper and lower core, through the coolant hose connecting piece, and towards the heater core.

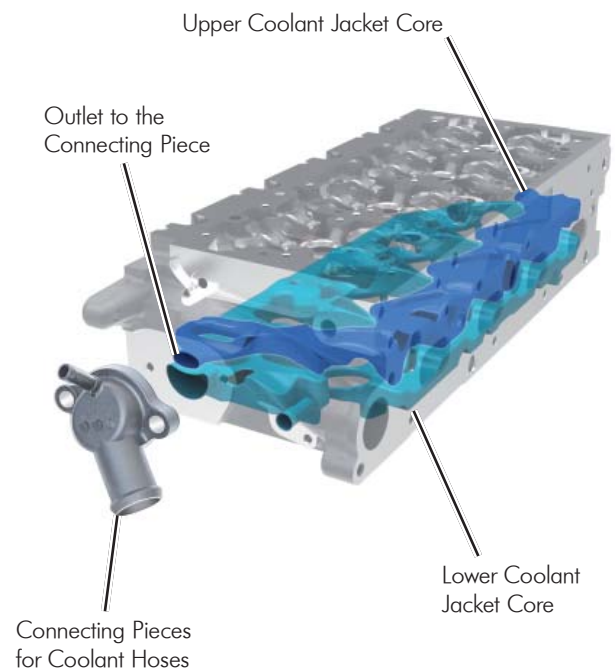

S514_047

Engine Mechanics

Crankcase Breather

The crankcase breather components are integrated into the cylinder head cover, with the oil filler neck and the pressure accumulator for the engine vacuum system.

Blow-by gases are returned to the intake side through the crankcase breather.

Crankcase venting takes place in several stages for efficient separation. First, the blow-by gases travel from the crankshaft and camshaft chamber into the "settling volume" area of the cylinder head cover. This is where larger oil drops collect on the walls and drip down into the cylinder head. Then the oily gases are separated from gas fumes in a cyclone separator. The pressure control valve regulates the transfer of purified gases to the intake manifold, where they enter the combustion chamber.

To prevent the passages from freezing in cold climate countries, a heater element is used in the crankcase breather.

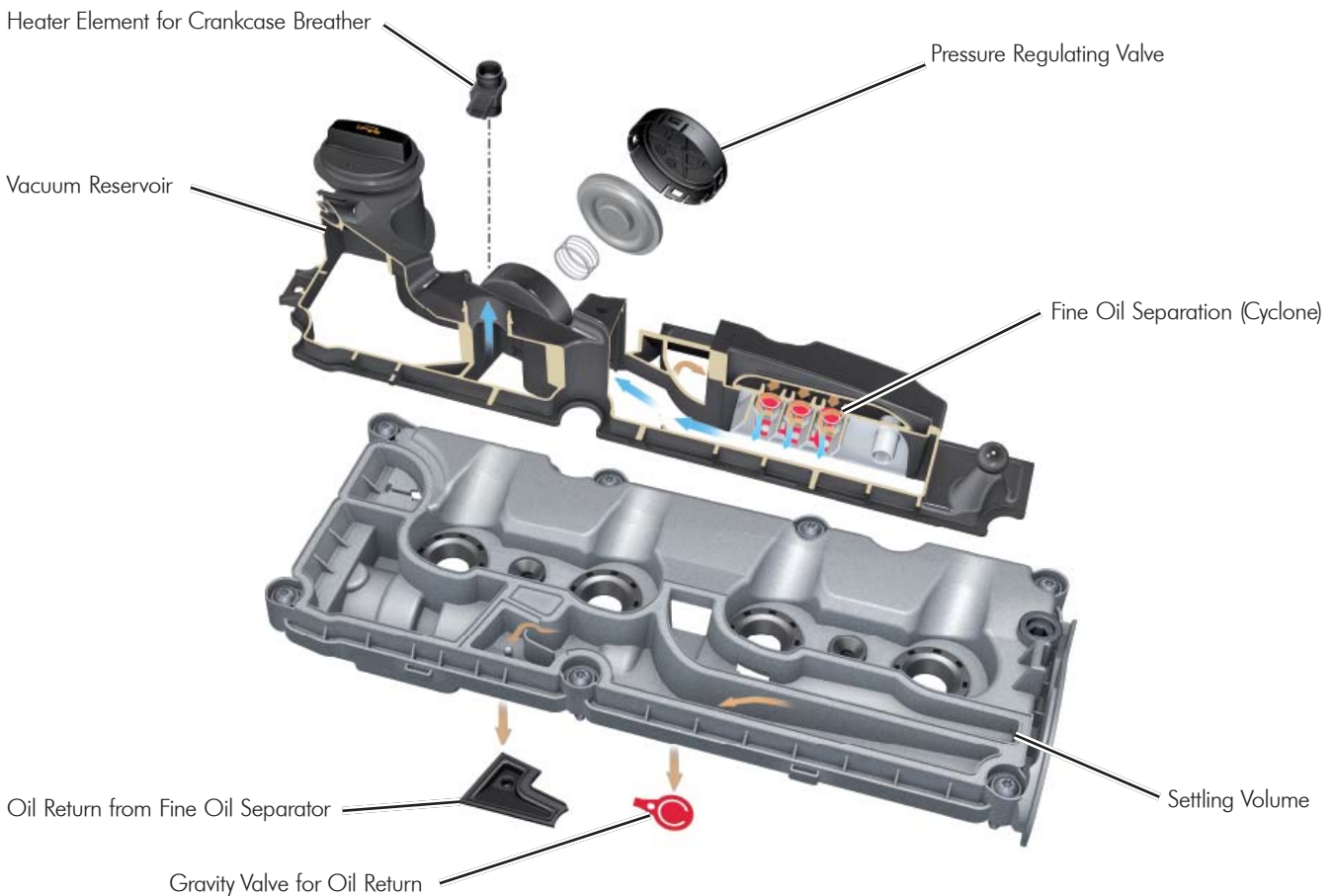

S514_011

Oil Circuit

Engine oil pressure is generated by a flow-rate controlled oil pump. The oil pump operates in either a high or low-pressure setting, depending on operating requirements.

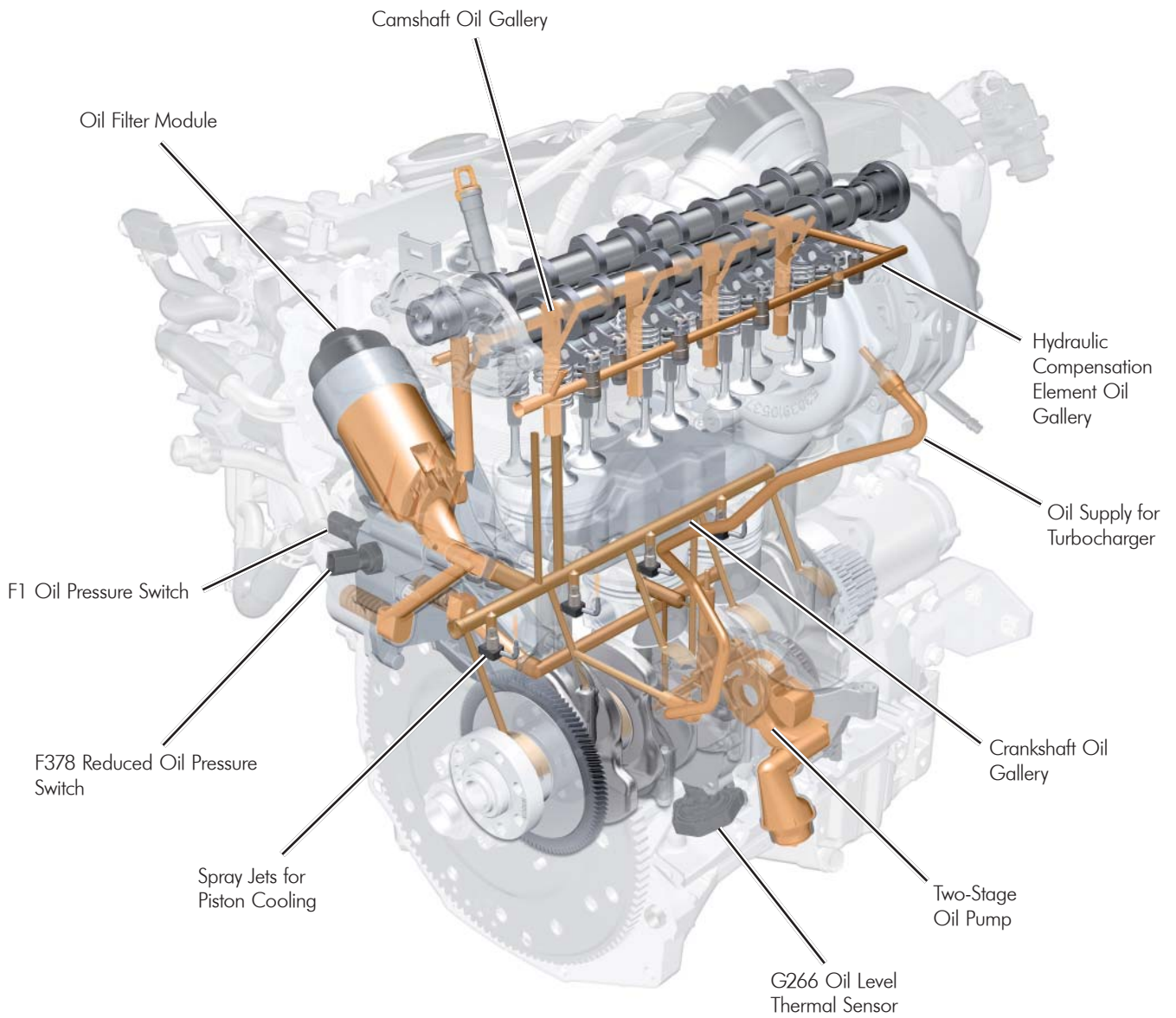

Engine Mechanics

Oil and Vacuum Pumps

The oil pump and a vacuum pump are combined in a housing on the bottom of the cylinder block. These pumps share a common drive shaft. This drive shaft is driven by the crankshaft using a toothed belt. The maintenance-free toothed belt runs directly in the oil. The tension on the belt is not adjustable and is created by the placement of the sprockets.

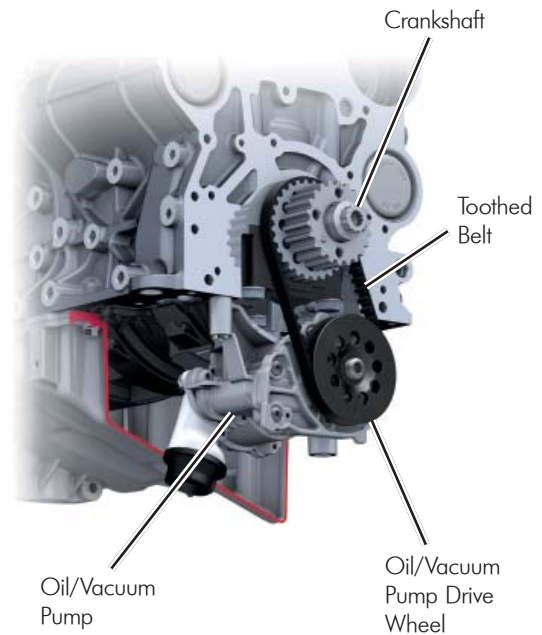

S514_009

Pump Connections

The N428 Oil Pressure Regulation Valve is installed above the sump in the cylinder block. Next to the oil pressure control valve, a connection for a vacuum line leads to the engine vacuum system. The vacuum line is connected to the vacuum pump by a galley in the cylinder block.

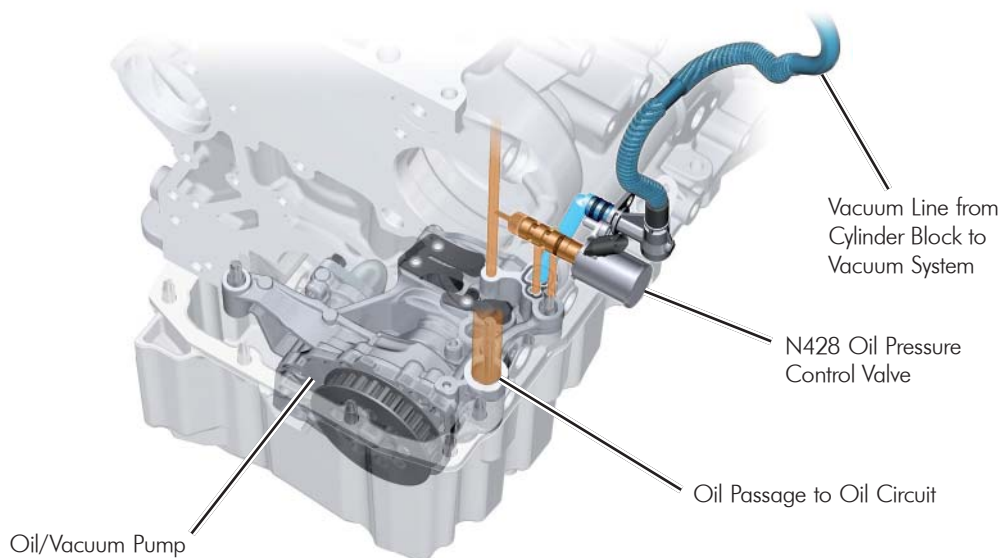

S514_010

Vacuum Pump

The vacuum pump draws air from the brake servo and the engine vacuum system and directs it through the flutter valves to the cylinder block.

Oil to lubricate the vacuum pump passes through the flutter valves from the vacuum pump pressure chamber to the sump.

Design

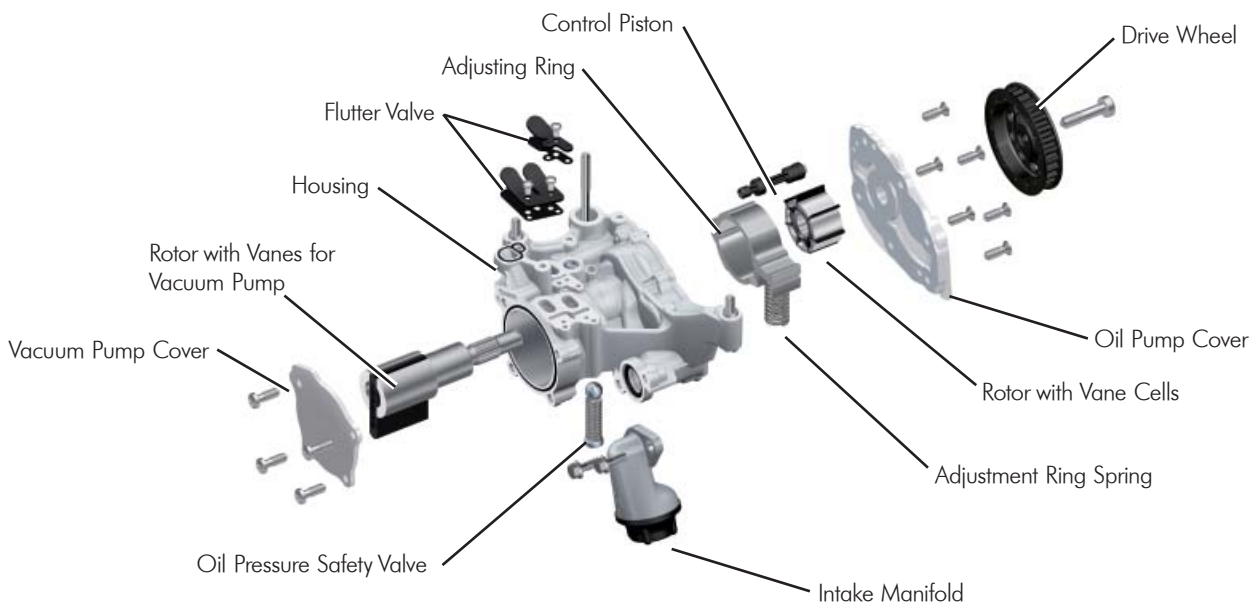

S514_012

Oil Pump

The oil pump is a flow-rate controlled vane pump that uses an eccentrically mounted adjustment ring to regulate pump delivery. The rotating adjustment ring position alters the flow rate of the pump; adjusting pump output to the engine operating conditions.

Oil Pressure Control

The oil pump switches between two pressure stages depending on engine load, speed and oil temperature. This reduces the power consumption of the oil pump significantly at times when high oil pump output is not necessary, such as in city driving or off-road driving.

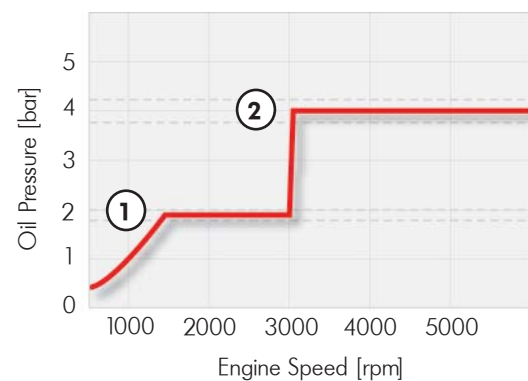

- ① Low-pressure stage: oil pressure 1.8 - 2.0 bar
- ② High-pressure stage: oil pressure 3.8 - 4.2 bar

S514_013

Engine Mechanics

Pressure Stage Control

Low Pressure Stage – Low Fuel Delivery Rate

In the lower engine load and speed range, a low level of pressure in the oil circuit is sufficient for supplying the engine components with enough oil. In this operating range, the pump delivery rate is lowered in order to reduce the output of the oil pump.

Function

The ECM switches the N428 Oil Pressure Regulation Valve by applying a ground to the valve currently under (terminal 15) voltage. This allows the valve to open the control port from the oil circuit to Control Face 2 of the control piston. The oil pressure now acts on both faces of the control piston, which increases the force that the control piston exerts against the control piston spring.

The control edge of the piston leaves a larger cross section free, directing a large quantity of oil to the pump control chamber. As soon as the oil pressure in the pump control chamber is greater than the force of the adjustment ring spring, the adjustment ring turns counter-clockwise. This reduces the delivery space between the vanes, and less oil is pumped into the oil circuit.

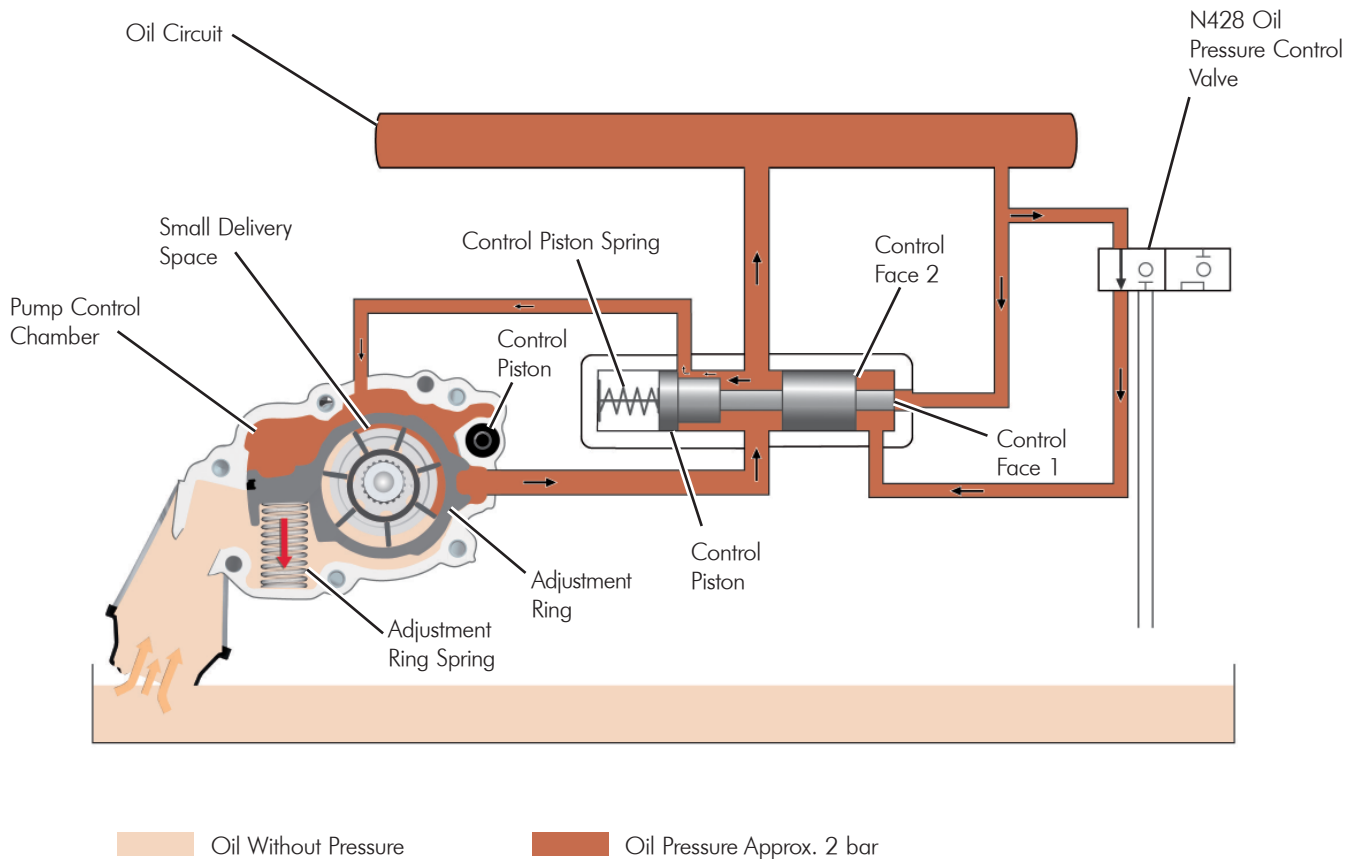

S514_015

High Pressure Stage – High Fuel Delivery Rate

When the engine is running at high speed or with a high engine load (e.g. full-load acceleration), higher oil pressure is required to lubricate engine components. In these operating ranges, the oil pump operates at a higher delivery rate.

Function

The N428 Oil Pressure Regulation Valve is not actuated by the ECM. Oil pressure only acts on Control Face 1 of the control piston. The control piston exerts a lower force against the control piston spring. As a result, the control edge of the piston only exposes a small passage to the pump control chamber, allowing only a small amount of oil to enter the pump control chamber. The oil pressure acting on the control face of the adjustment ring is lower than the force of the adjustment ring spring.

The adjustment ring turns clockwise, which increases the delivery space between the vane cells. The larger delivery space pumps more oil into the oil circuit.

Leaking oil from Control Chamber 2 of the control piston is guided to the sump through the control port and the valve for oil pressure control.

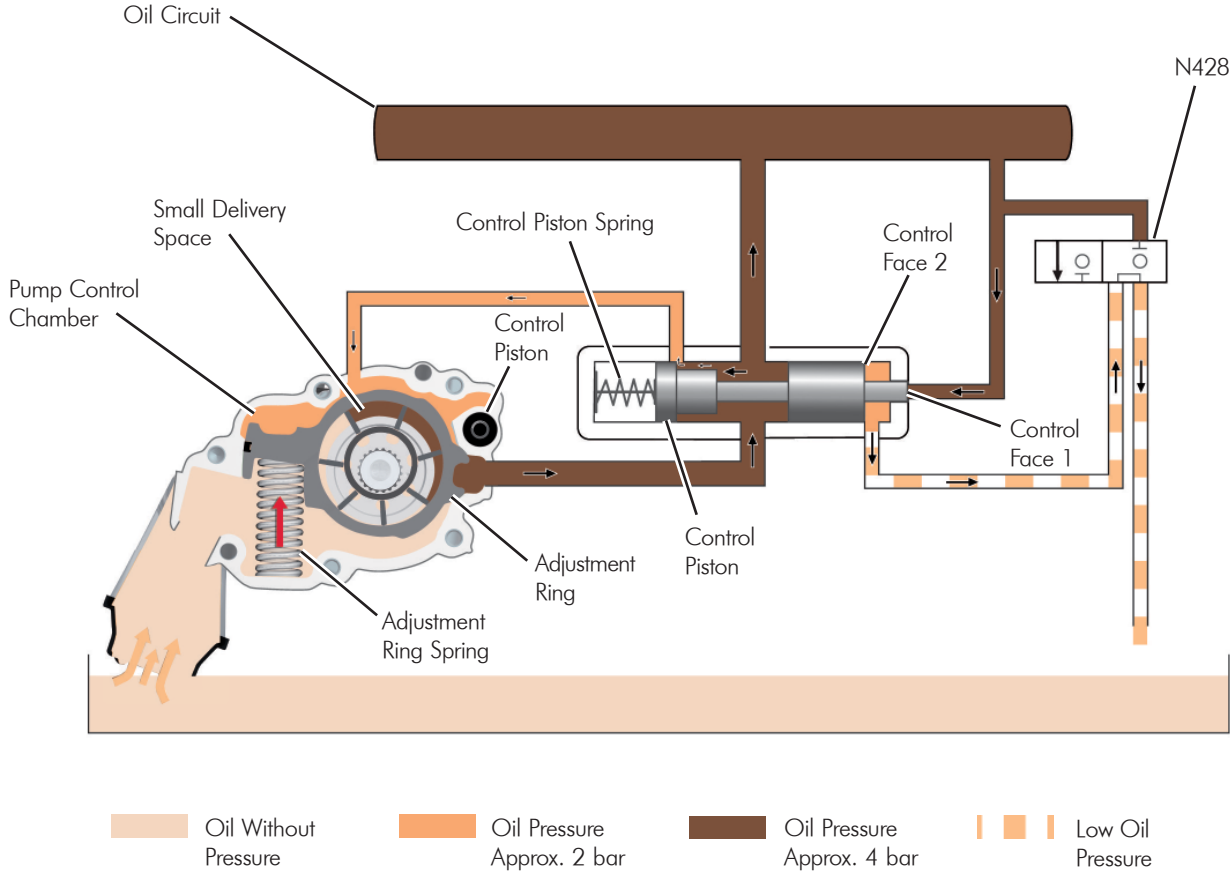

Engine Mechanics

Oil Filter Module

The oil filter module is the plastic casing of the oil filter and the aluminum oil cooler. This module is bolted to the cylinder block. Coolant passes from the cylinder block into this module, supplying the oil cooler with coolant. The oil filter bypass valve is integrated into the oil filter module. This valve opens if the oil filter becomes clogged to ensure lubrication of the engine.

Oil Pressure Switch

Oil pressure switches are used by the ECM to monitor engine oil pressure.

F378 Reduced Oil Pressure Switch

The signal from F378 is used to inform the driver that the oil pressure in the engine is too low.

The switch opens when the oil pressure falls below a range of 0.3 – 0.6 bar. The ECM then illuminates the oil pressure warning lamp in the instrument cluster.

F1 Oil Pressure Switch

The Oil Pressure Switch F1 is used to monitor oil pressure above the threshold of the N428 Oil Pressure Regulation Valve.

The switch closes at an oil pressure within a tolerance range of 2.3 – 3.0 bar. The signal tells the ECM that the oil pressure level is above the low pressure stage.

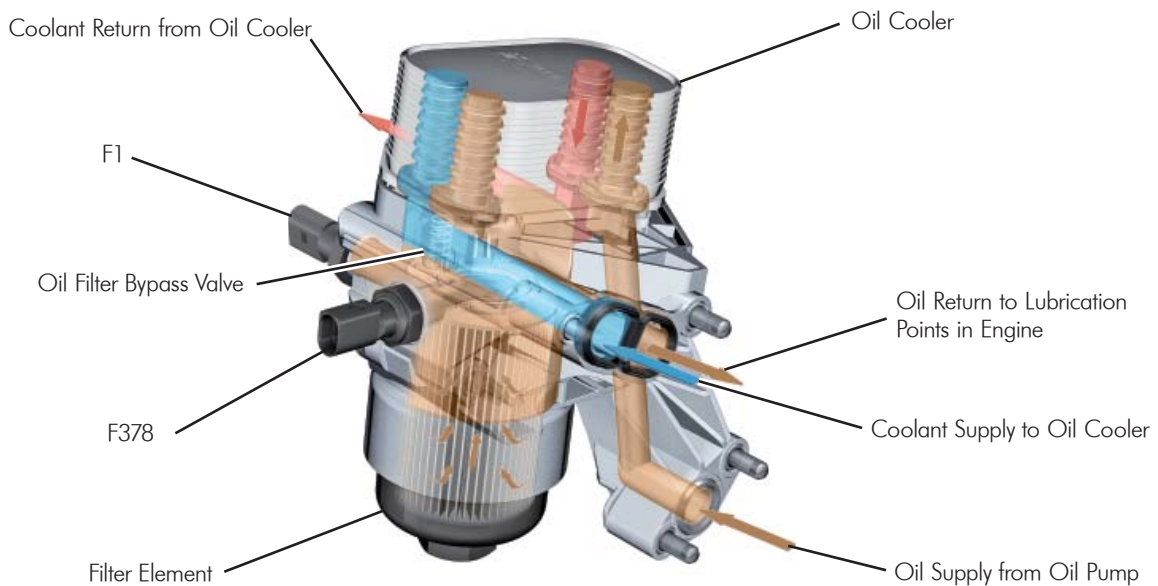

S514_019

G266 Oil Level Thermal Sensor

In the sump of the EA288 engine there is an electronic oil level and oil temperature sensor. The oil level in the sump is determined according to an ultrasound principle. Depending on the material or density of an obstacle, ultrasound waves are distributed differently or are reflected. Air and oil have different densities.

In oil, the ultrasound waves spread with little distortion. In air, on the other hand, ultrasound waves are subject to considerably greater distortion. When using ultrasound waves to determine oil level, the ultrasound waves are reflected at the oil and air boundary. This reflection is used to determine the oil level.

The current oil temperature is recorded by a PTC temperature sensor integrated into the component.

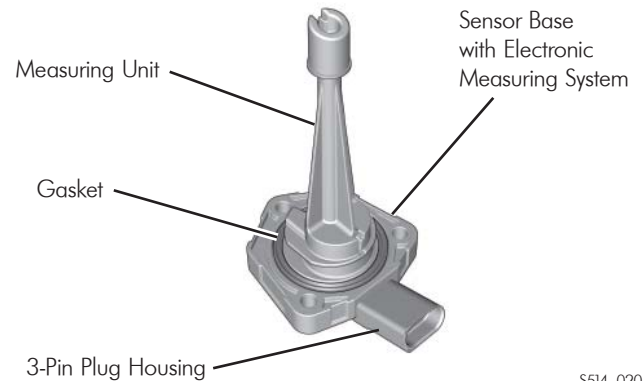

S514_020

Design and Functional Principle

The electronic measuring system for the oil level and the oil temperature, and the electronics needed to evaluate this data, are integrated into the sensor base. The electronic measuring system for the oil level sends ultrasound waves into the oil sump. The ultrasound waves are reflected at the boundary layer between oil and water and are picked up again by the electronic measuring system. The analysis electronics calculate the oil level from the time difference between the sent and reflected signal. In addition to the oil level, the oil temperature is calculated with a PTC temperature sensor. A pulse width modulated (PWM) signal is used to send oil level and oil temperature values to the ECM.

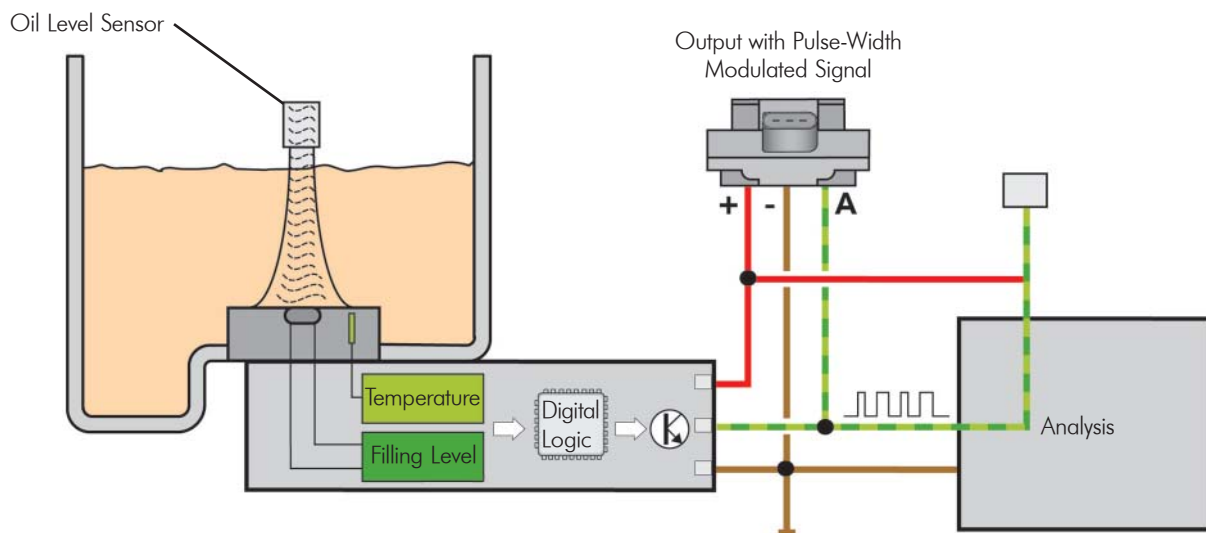

S514_021

Engine Mechanics

Thermal Management

A thermal management system controls the cooling system in the EA288 engine.

The thermal management system is used for optimum distribution of the available engine heat while taking into account the heating and cooling demands of the interior, engine and transmission. The thermal management system heats the engine quickly in the warm-up phase after a cold start.

The heat produced by the engine is directed to the components of the cooling system in a targeted manner. Using the heat available in the cooling system efficiently reduces internal engine friction, which reduces fuel consumption and exhaust emissions. The interior of the vehicle is also brought up to a comfortable temperature quicker.

Coolant Circuits

The coolant circuit consists of three partial coolant circuits to ensure heat distribution is based on demand.

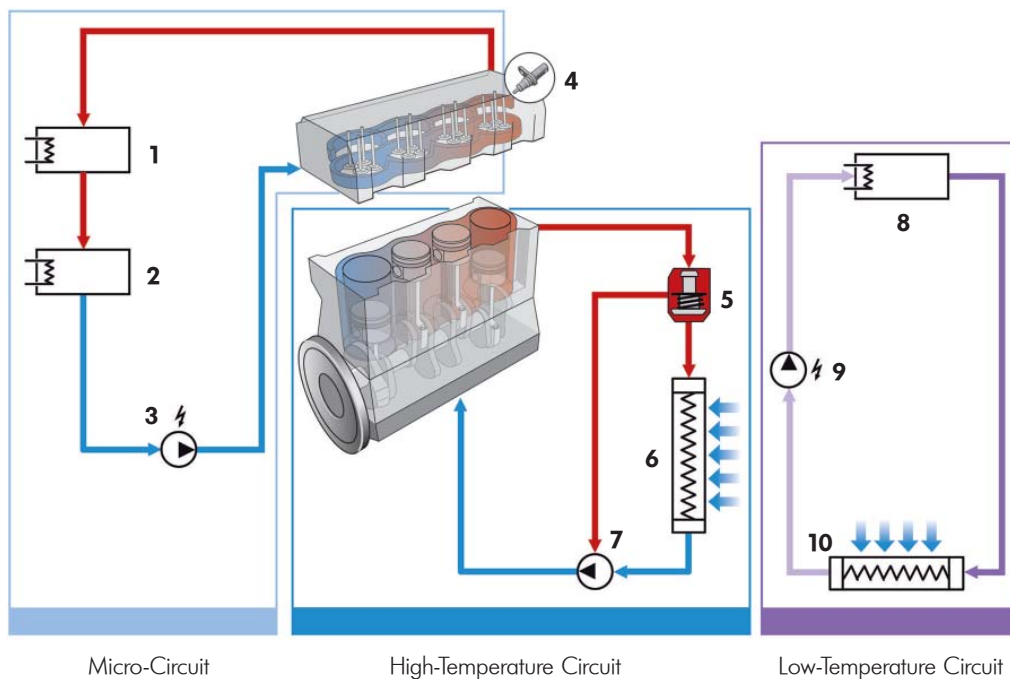

Key

- | | |
|---|--|
| 1 Exhaust Gas Recirculation Cooler | 6 Radiator |
| 2 Heat Exchanger for Heater | 7 Coolant Pump |
| 3 V488 Heater Support Pump | 8 Charge Air Cooler |
| 4 G62 Engine Coolant Temperature Sensor | 9 V188 Charge Air Cooling Pump |
| 5 Thermostat | 10 Water Radiator for Charge Air Cooling Circuit |

S514_082

Switchable Coolant Pump

The EA288 engine has a switchable coolant pump that works with the N489 Cylinder Head Coolant Valve. When the engine is cold, N489 pushes a modulating piston in the form of a shroud over the rotating pump impeller, preventing the coolant from circulating. This condition is also called "static coolant." Static coolant heats faster and shortens the engine warm-up phase.

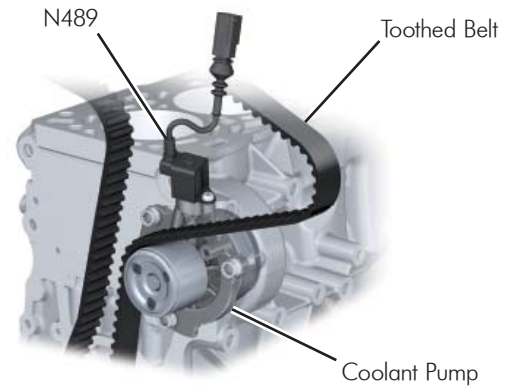

S514_022

Design

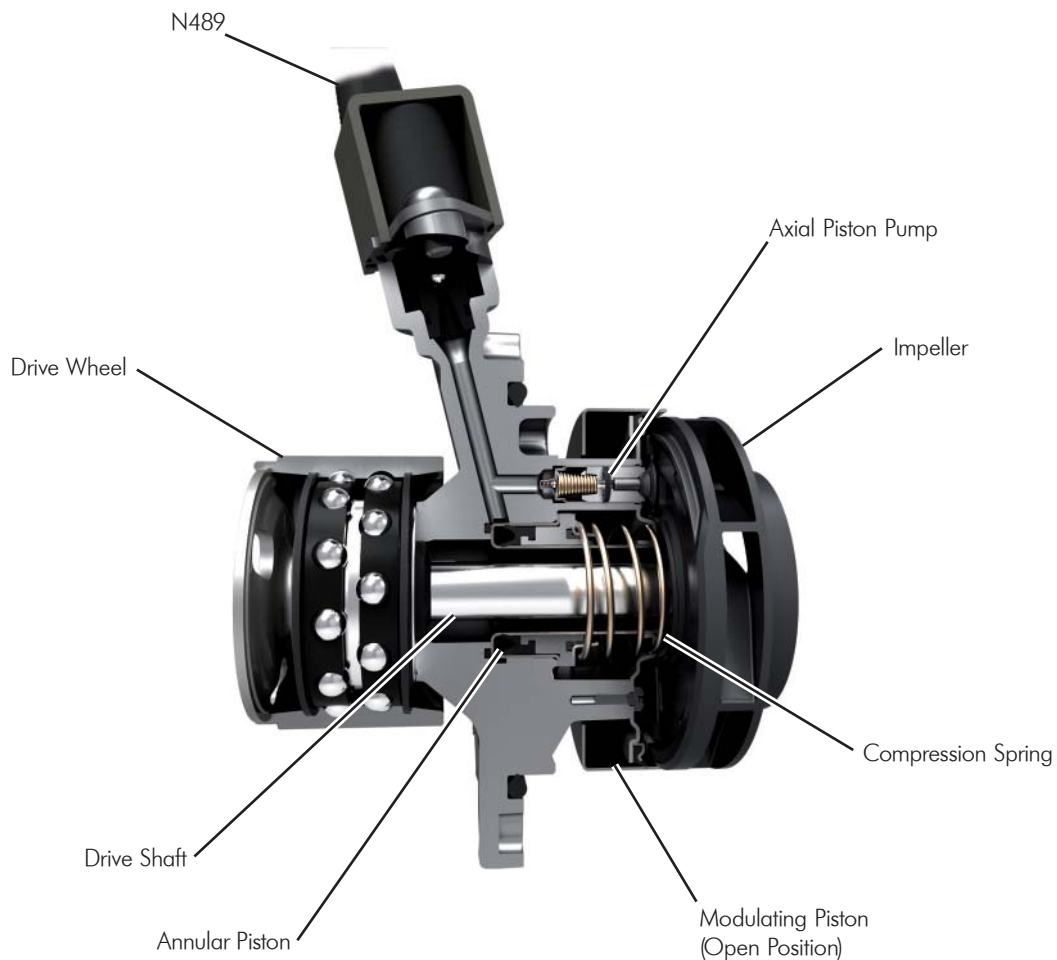

S514_048

Engine Mechanics

Static Coolant

To generate static coolant, the axial piston pump is permanently powered by a stroke contour on the back of the impeller.

When N489 is actuated by the ECM, the pump-integrated hydraulic circuit is closed. This builds up pressure on the annular piston. This pressure counteracts the force of the compression springs, and pushes the modulating piston over the pump impeller.

N489 Cylinder Head Coolant Valve, Actuated

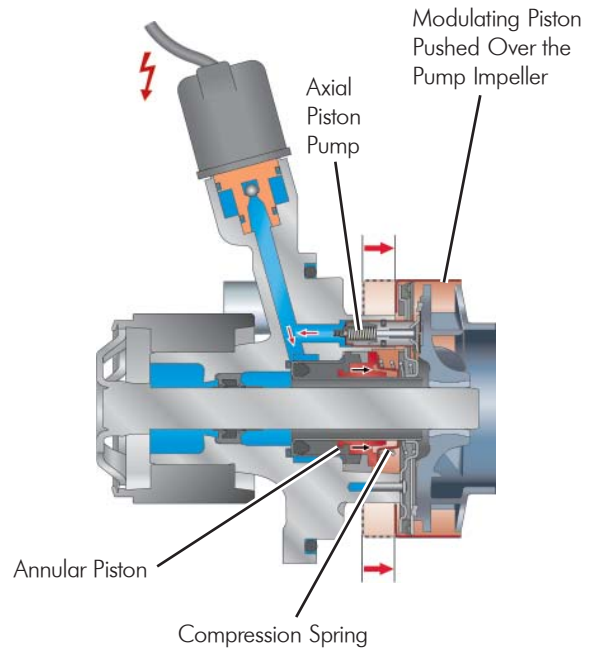

SS14_023

Coolant Circulates

If the N489 has been de-energized, the return channel to the engine coolant circuit is open. No hydraulic pressure acts on the annular piston. The modulating piston is pushed back to its initial position by the compression spring. The impeller is released, ensuring that the coolant circulates in the engine coolant circuit.

N489, Not Actuated

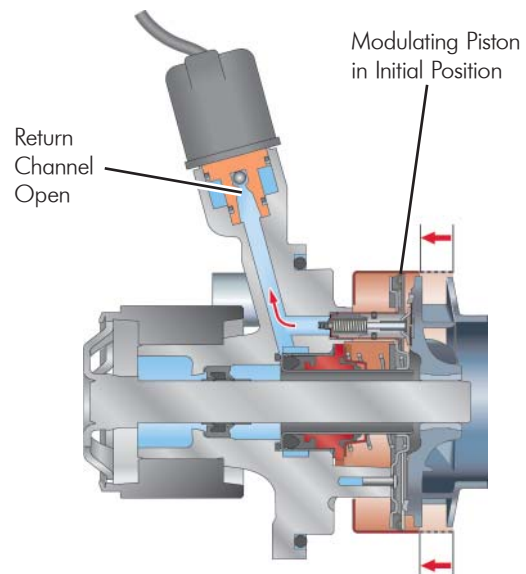

SS14_024

Effects of Failure

If the N489 is defective, the modulating piston remains in its initial position and the coolant flows around the coolant circuit.

Thermostat

The thermostat is a 3/2-way valve and is activated via a wax element. Depending on the coolant temperature, the thermostat switches between the large and the small coolant circuit.

Warm-Up Phase

In the warm-up phase of the engine, the path of the coolant from the cylinder block to the main radiator is blocked by a large disc in the thermostat. The coolant enters the small coolant circuit directly from the coolant pump.

The coolant is not circulating because the coolant pump is off, and the engine reaches its operating temperature faster. When the coolant pump turns on, it provides coolant to the cylinder head and the EGR cooler during the engine warm-up phase.

Operating Temperature

At a coolant temperature of approximately 87 °C, the large disc in the thermostat starts to open and joins the radiator into the large coolant circuit. At the same time, the small disc in the thermostat blocks the direct path to the coolant pump.

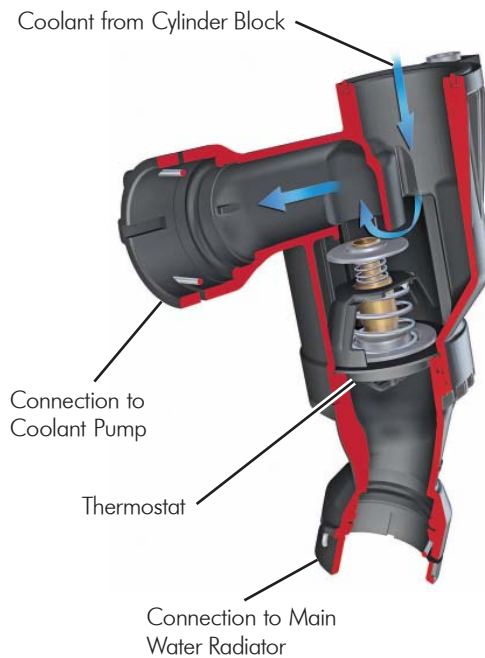

S514_025

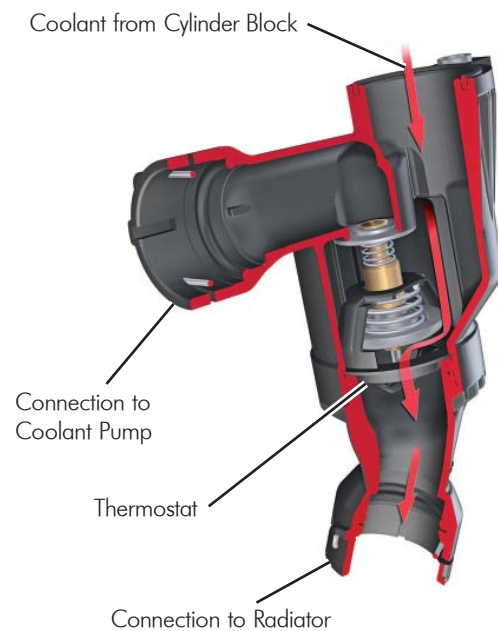

S514_026

Engine Mechanics

Coolant Circuit – General Overview

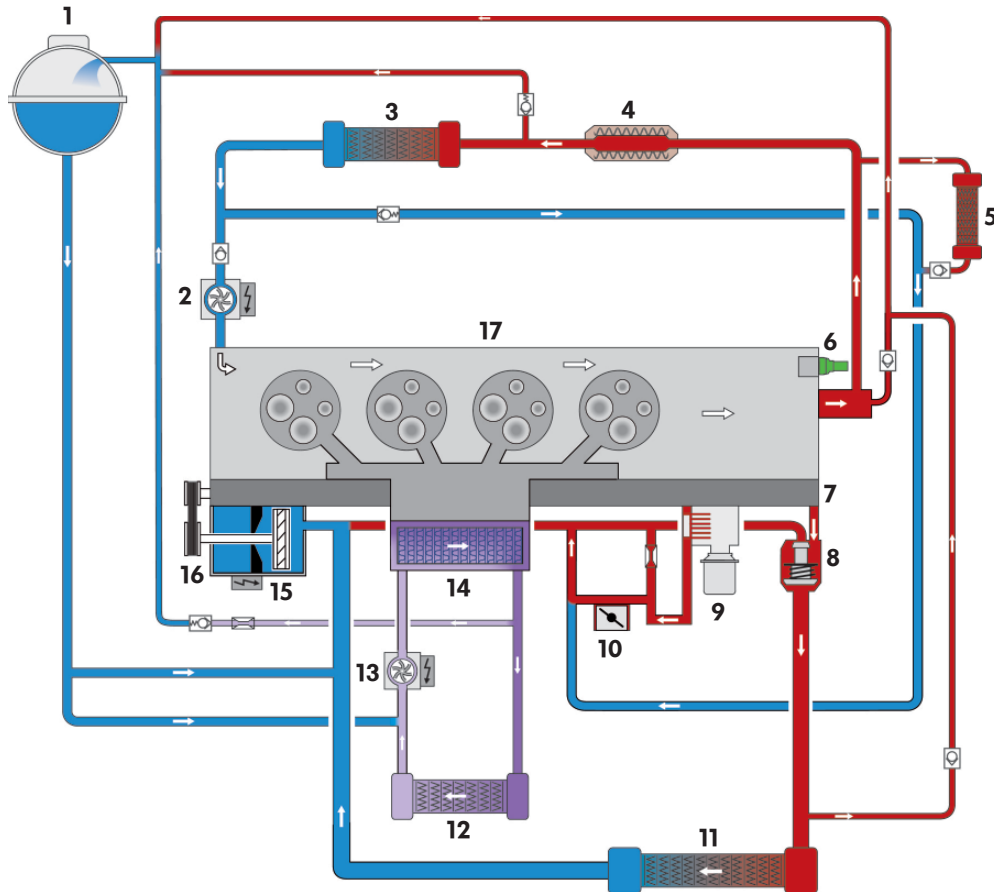

S514_045

Key

- | | | | |
|----|---|----|----------------------------------|
| 1 | Coolant Expansion Tank | 15 | N489 Cylinder Head Coolant Valve |
| 2 | V488 Heater Support Pump | 16 | Coolant Pump |
| 3 | Heat Exchanger for Heater | 17 | Cylinder Head |
| 4 | Exhaust Gas Recirculation Cooler | | |
| 5 | Gear Oil Cooler | | |
| 6 | G62 Engine Coolant Temperature Sensor | | |
| 7 | Cylinder Block | | |
| 8 | Thermostat | | |
| 9 | Engine Oil Cooler | | |
| 10 | J338 Throttle Valve Control Module | | |
| 11 | Radiator | | |
| 12 | Water Radiator for Charge Air Cooling Circuit | | |
| 13 | V188 Charge Air Cooling Pump | | |
| 14 | Charge Air Cooler | | |



Always follow the instructions in the Repair Information when performing coolant system service. The coolant system must be bled using the scan tool test plans

Micro-Circuit

If the engine is cold, the thermal management starts with the micro-circuit, allowing for fast heating of the engine and the passenger compartment. During this fast heating of the coolant, the coolant thermostat remains closed to the radiator.

The circulation of the coolant in the large circuit is prevented by the modulating piston of the switchable coolant pump being pushed over the pump impeller. The resultant "static coolant" heats quickly ensuring that the engine does too.

The coolant in the micro-circuit is moved by the V488 Heater Support Pump. This pump is actuated by the ECM as needed, depending on the coolant temperature in the cylinder head.

The requested passenger compartment temperature is provided by the Climatronic control module and is taken into account when actuating V488.

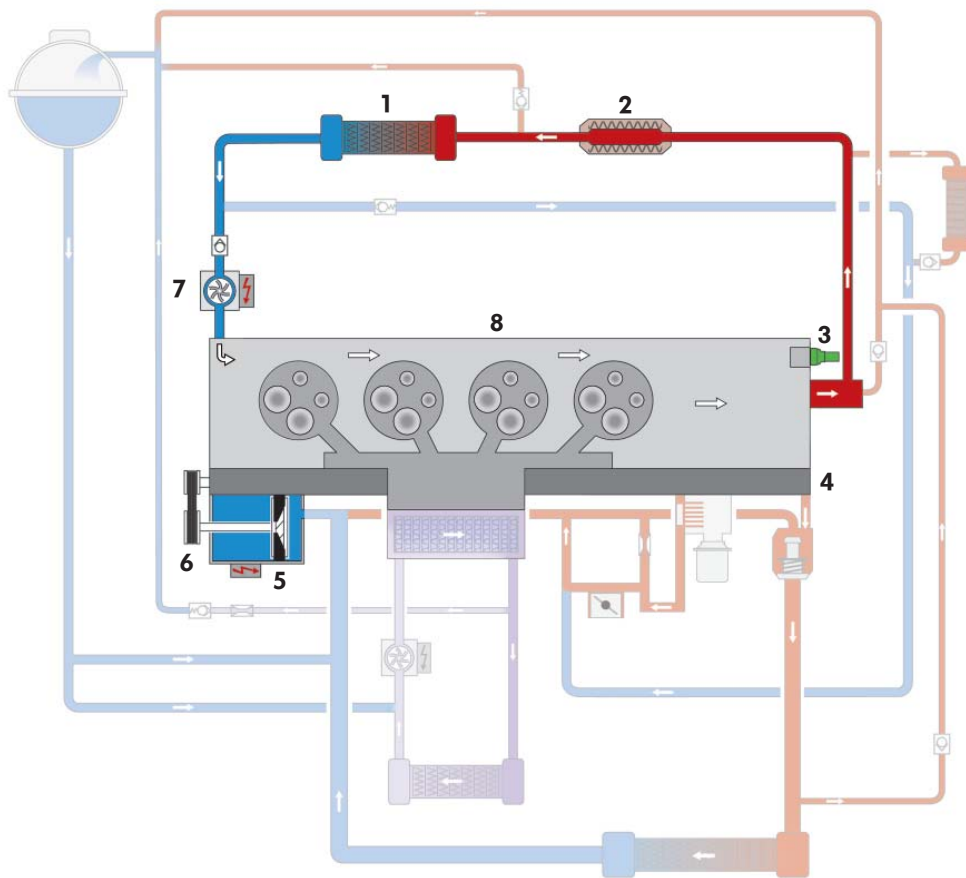

Key

- | | | | |
|---|---------------------------------------|---|----------------------------------|
| 1 | Heater Core | 5 | N489 Cylinder Head Coolant Valve |
| 2 | EGR cooler | 6 | Coolant Pump |
| 3 | G62 Engine Coolant Temperature Sensor | 7 | V488 Heater Support Pump |
| 4 | Cylinder Block | 8 | Cylinder Head |

S514_071

Engine Mechanics

Micro-Circuit at High Engine Load

If the engine load and speed exceeds a threshold value, the switchable coolant pump is turned on to ensure that the engine is cooled. The coolant pump is turned off when the engine speed drops below a defined level and the engine is not yet warm enough.

As soon as the coolant temperature of the cylinder head reaches a value that indicates that the engine has warmed up, the coolant pump runs continuously, providing coolant to the cylinder head.

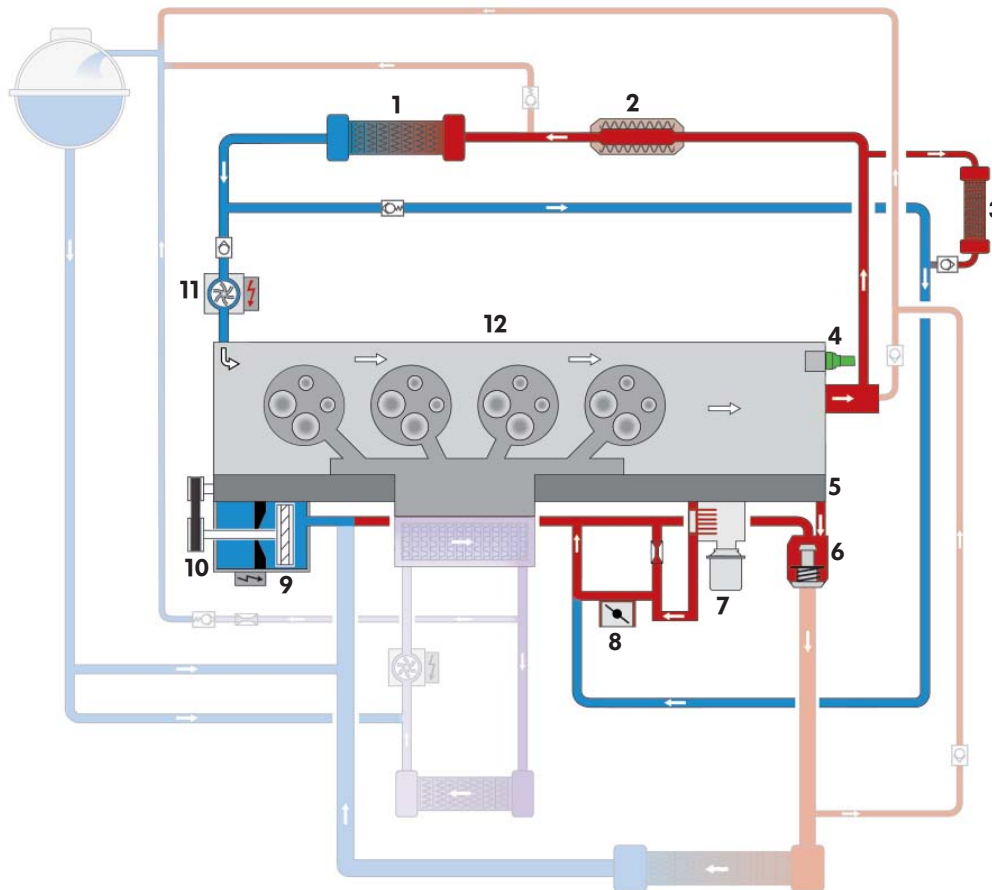

SS14_072

Key

- | | | | |
|---|---------------------------------------|----|--------------------------------------|
| 1 | Heat Exchanger for Heater | 7 | Engine Oil Cooler |
| 2 | Exhaust Gas Recirculation Cooler | 8 | Throttle Valve Module J338 |
| 3 | Gear Oil Cooler | 9 | Coolant Valve for Cylinder Head N489 |
| 4 | G62 Engine Coolant Temperature Sensor | 10 | Coolant Pump |
| 5 | Cylinder Block | 11 | V488 Heater Support Pump |
| 6 | Thermostat | 12 | Cylinder Head |

Large Cooling Circuit (High-Temperature Circuit)

When the coolant has reached operating temperature, the thermostat opens and integrates the radiator into the coolant circuit.

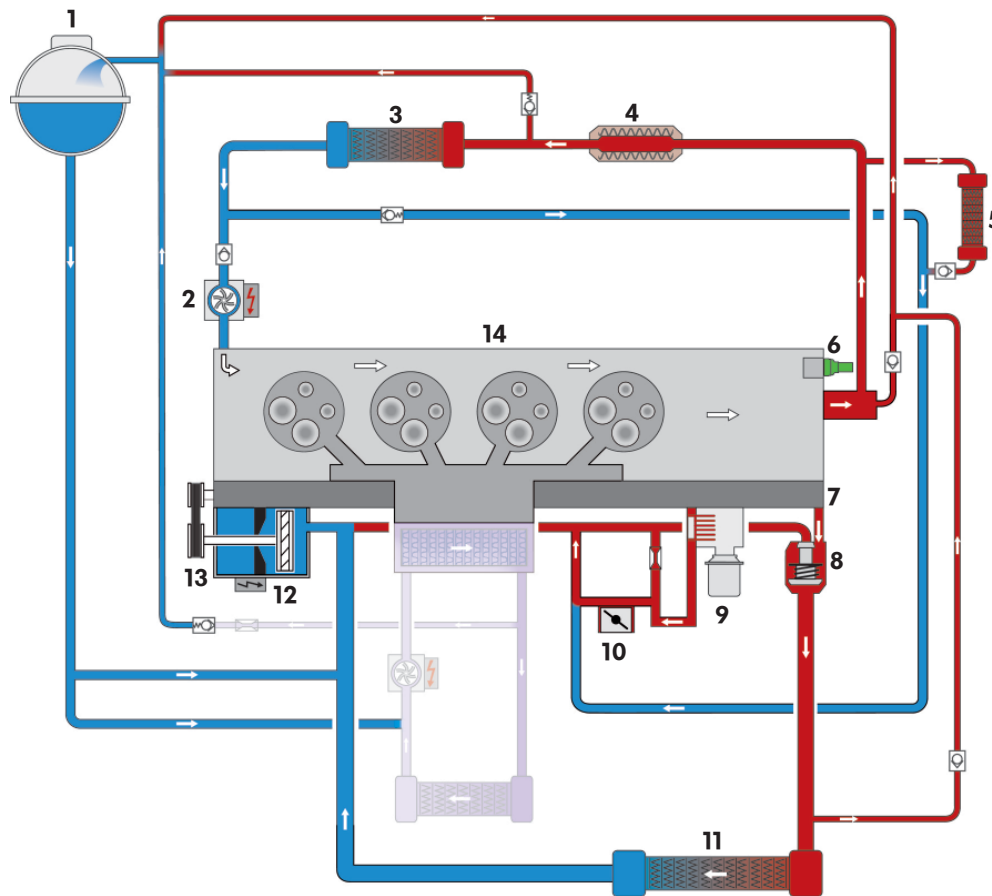

SS14_073

Key

- | | | | |
|---|---------------------------------------|----|------------------------------------|
| 1 | Coolant Expansion Tank | 8 | Thermostat |
| 2 | V488 Heater Support Pump | 9 | Engine Oil Cooler |
| 3 | Heat Exchanger For Heater | 10 | J338 Throttle Valve Control Module |
| 4 | Exhaust Gas Recirculation Cooler | 11 | Radiator |
| 5 | Gear Oil Cooler | 12 | N489 Cylinder Head Coolant Valve |
| 6 | G62 Engine Coolant Temperature Sensor | 13 | Coolant Pump |
| 7 | Cylinder Block | 14 | Cylinder Head |

Engine Mechanics

Charge Air Cooling Coolant Circuit (Low-Temperature Circuit)

The charge air cooling system adjusts the intake manifold air temperature using a liquid coolant radiator. The charge air temperature is regulated by the ECM, which activates the V188 Charge Air Cooling Pump to regulate the charge air temperature. The intake manifold temperature after the charge air cooler provides the reference value for actuating V188.

The coolant circuit for charge air cooling is connected to the engine coolant circuit by a non-return valve and a restrictor for filling and bleeding. During operation, there is no connection to the engine coolant circuit.

Actuation conditions of the V188:

- If the charge air temperature is below the target value, the pump is turned off or remains off
- If the intake manifold temperature is equal to or somewhat higher than the target value, the pump is activated in a cycle. The on and off times (cycle times) depend on the charge air temperature and the ambient air temperature
- If the charge air temperature is significantly above the target temperature, the charge air cooling pump is run continuously at full power

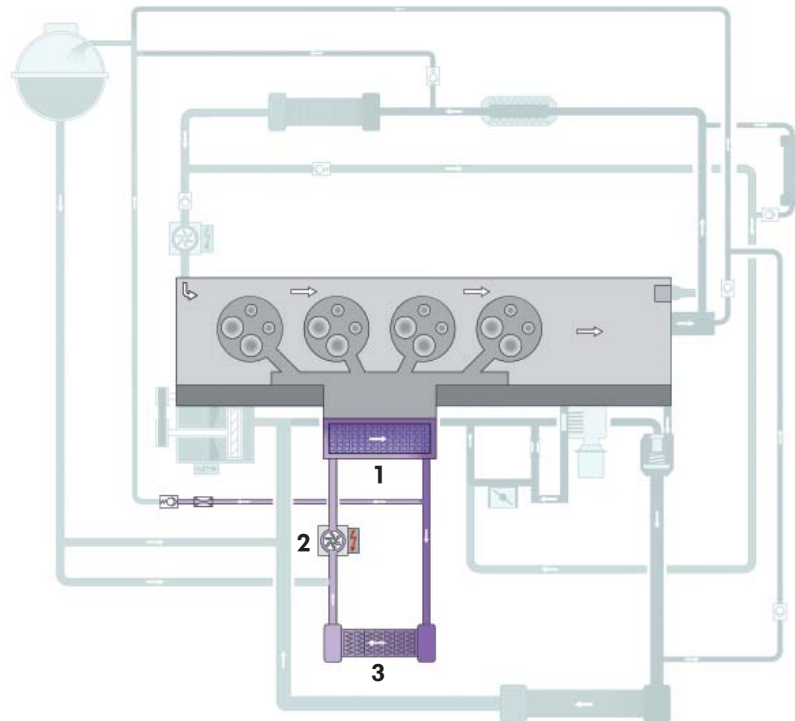

Key

- 1 Charge Air Cooler
- 2 V188
- 3 Water Radiator for Charge Air Cooling Circuit

SS14_074

G62 Engine Coolant Temperature Sensor

The coolant temperature sensor is screwed into the cylinder head close to the combustion chamber, allowing the ECM to more accurately monitor engine coolant temperature under all driving modes.

Signal Use

The ECM uses the signal from the coolant temperature sensor to adjust injection quantity, cylinder charge pressure, and EGR quantity. The coolant temperature signal is also used to turn the switchable coolant pump on and off.

Effects of Signal Failure

In the event of signal failure, the ECM uses a fixed substitute value for calculation purposes. The switchable coolant pump remains on.

Electronically Controlled Coolant Pumps

V488 Heater Support Pump

The heater support pump is an electronically regulated centrifugal pump with brushless drive. It is used for the micro-circuit. The pump is actuated by a PWM signal by the ECM.

V188 Charge Air Cooling Pump

The charge air cooling pump is an electronically regulated centrifugal pump with brushless drive. It draws coolant from the water radiator for the charge air coolant circuit and pumps it to the charge air cooler. The pump is actuated by a PWM signal from the ECM.



Engine Mechanics

Coolant Pump Control

Both electronically regulated coolant pumps have control electronics. The control electronics use the PWM signal from the ECM to calculate the rotational speed for the pump and actuate the electric motor. The power consumed by the electric motor is monitored by the control electronics.

The control electronics report the actual state of the pump to the ECM by connecting the PWM signal from the ECM to ground at set intervals. This process runs in cycles whenever the pump is running.

“Pump OK” Detected

During pump operation, the control electronics switch the PWM signal from the ECM to ground for 0.5 seconds in 10-second intervals. This tells the ECM that the pump is ready for operation.

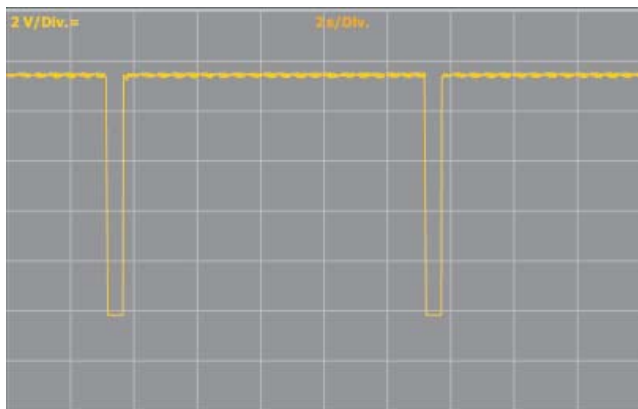

“Pump not OK” Detected

If the self-diagnosis detects a fault, e.g. caused by a blocked pump or a dry-running pump, the control electronics change the duration of the ground, by adjusting the PWM signal.

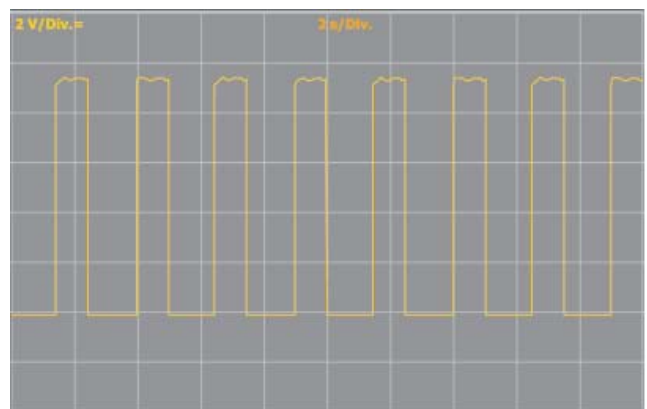

Effects of Electronically Controlled Coolant Pump Failures

Cause of fault	Effect
Electrical fault or mechanical fault	<ul style="list-style-type: none"> • Entry in engine control module event memory • K83 Malfunction Indicator Lamp lights up
Open circuit in signal line	<ul style="list-style-type: none"> • Entry in engine control module event memory • K83 lights up • Pump running at top speed
Open circuit in a pump voltage supply wire	<ul style="list-style-type: none"> • Entry in engine control module event memory • K83 lights up • Pump does not work

Coolant Expansion Tank with Silicate Repository

The coolant expansion tank contains a silicate repository. Silicate is used to protect the aluminum components in the coolant system from corrosion. There are silicates in the G13 coolant, but they are used up over time if the engine is subject to high thermal loads.

To compensate for the silicate consumption, silicate is taken from the repository and added to the coolant. The silicate repository provides additional protection against corrosion for the aluminum components in the coolant system over the entire lifespan of the engine.

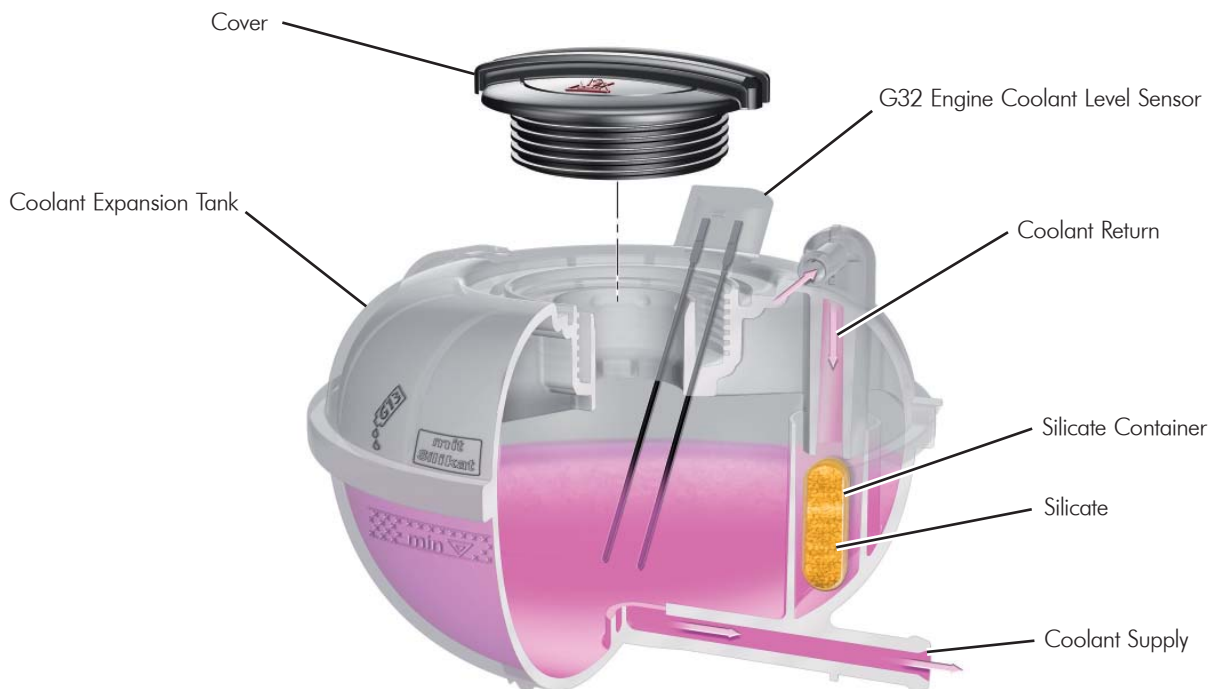

S514_079

Engine Mechanics

Fuel System

1 - J538 Fuel Pump Control Module

The fuel pump control module controls the pressure in the fuel supply and monitors the function of the fuel pump.

2 - G6 Transfer Fuel Pump

The fuel pump supplies the high-pressure pump with fuel.

3 - Fuel Filter

The fuel filter keeps impurities in the diesel fuel away from the components of the injection system. The high-pressure pump and the injectors can be damaged or plugged by even the most minute particles of dirt.

4 - G81 Fuel Temperature Sensor

The fuel temperature sensor measures the current fuel temperature.

5 - High-Pressure Pump

The high-pressure pump generates the high fuel pressure required for injection.

6 - N290 Fuel Metering Valve

The fuel metering valve regulates the quantity of fuel needed to generate the high pressure as required.

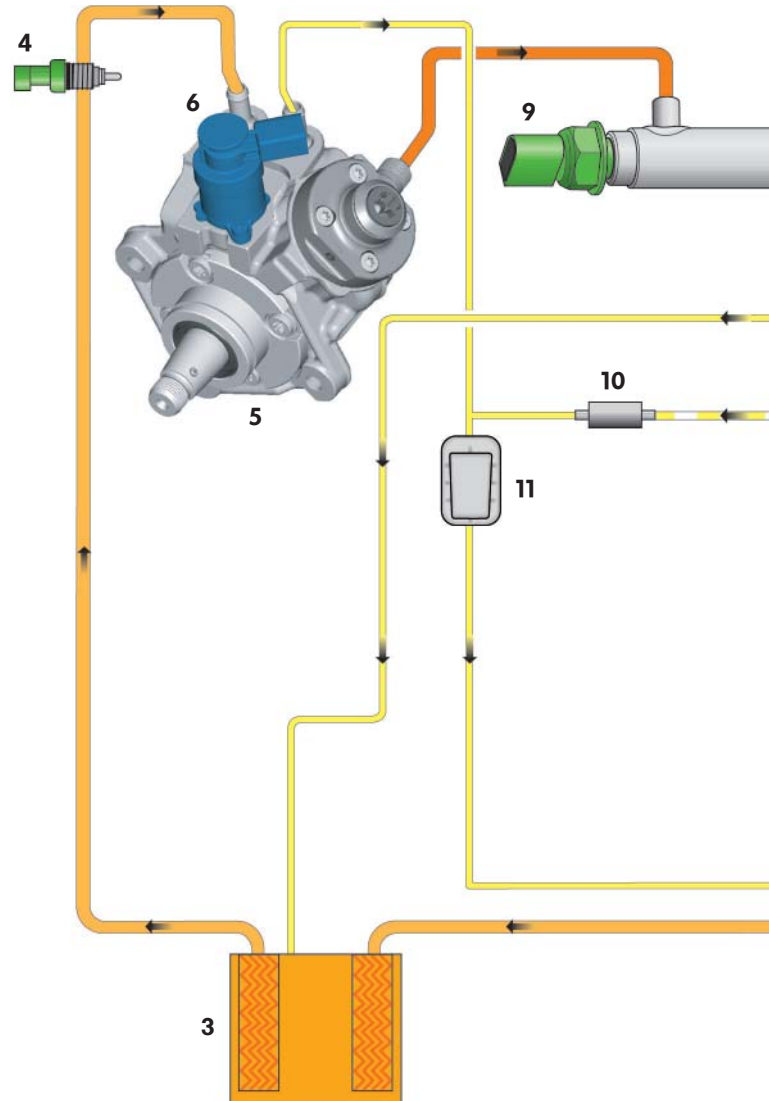

Key

 Fuel High Pressure Max. 1800 bar

 Fuel Return 0 – 1.0 bar

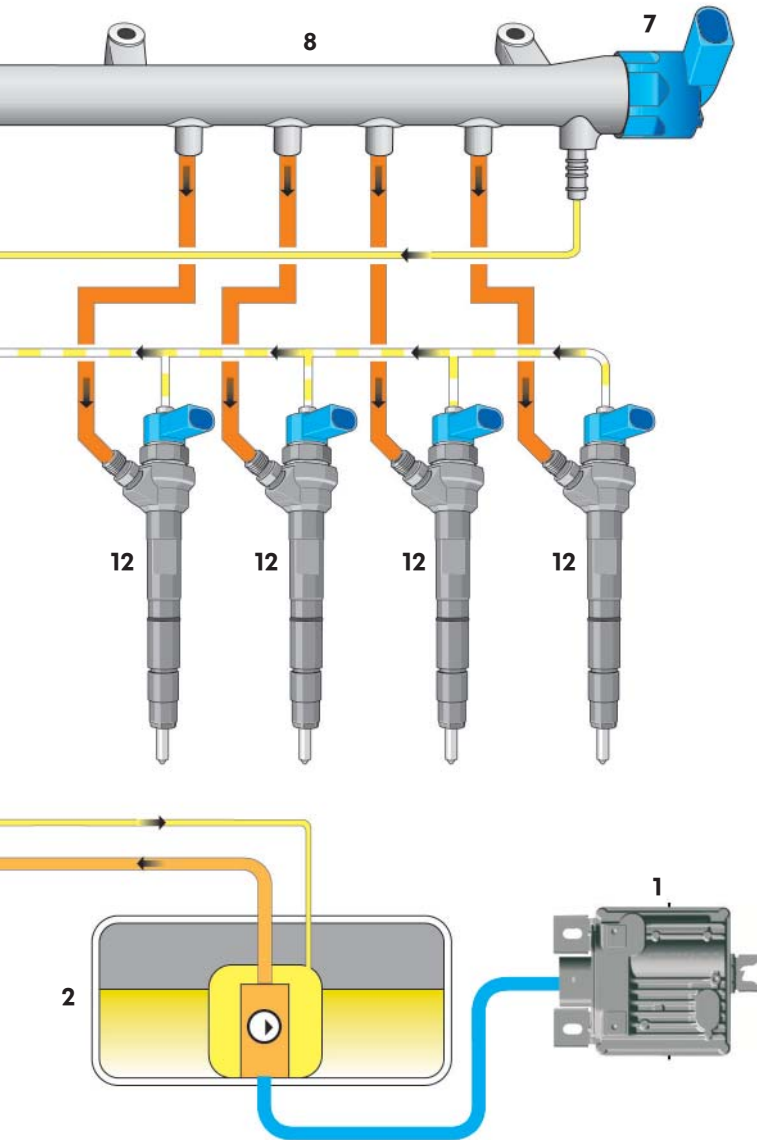

7 - N276 Fuel Pressure Regulator Valve

The fuel pressure regulating valve is used to adjust the fuel pressure in the high-pressure fuel circuit.

8 - High-Pressure Accumulator (rail)

The high-pressure accumulator stores the fuel required for injection into all cylinders under high pressure.

9 - G247 Fuel Pressure Sensor

The fuel pressure sensor measures the current fuel pressure in the high-pressure area.

10 - Pressure Retention Valve

The pressure retention valve ensures a constant pressure of about 1 bar in the injector return lines. This helps prevent variations in pressure and allows precise control of the injectors.



11 - Pulsation Damper

The pulsation damper reduces noises caused by pulsating fuel in the fuel return line.

12 - N30, N31, N32, N33 Cylinder 1 - 4 Fuel Injectors

The injectors inject the fuel into the combustion chambers.

S514_027

-  Fuel Supply Pressure 3.5 - 5.0 bar as Required
-  Fuel Return Pressure from the Injectors 0.4 - 1.0 bar

Engine Mechanics

Injector

Bosch has developed an injector with solenoid valve technology to operate at high injection pressures and perform several injections per work cycle. In the past only injectors with piezo actuators were able to meet these performance demands. Solenoid valve-controlled injectors are simpler to manufacture than injectors with a piezo actuator.

The Bosch injectors in the EA288 are controlled by a solenoid valve actuator.

Each external clamping piece holds two injectors in place.

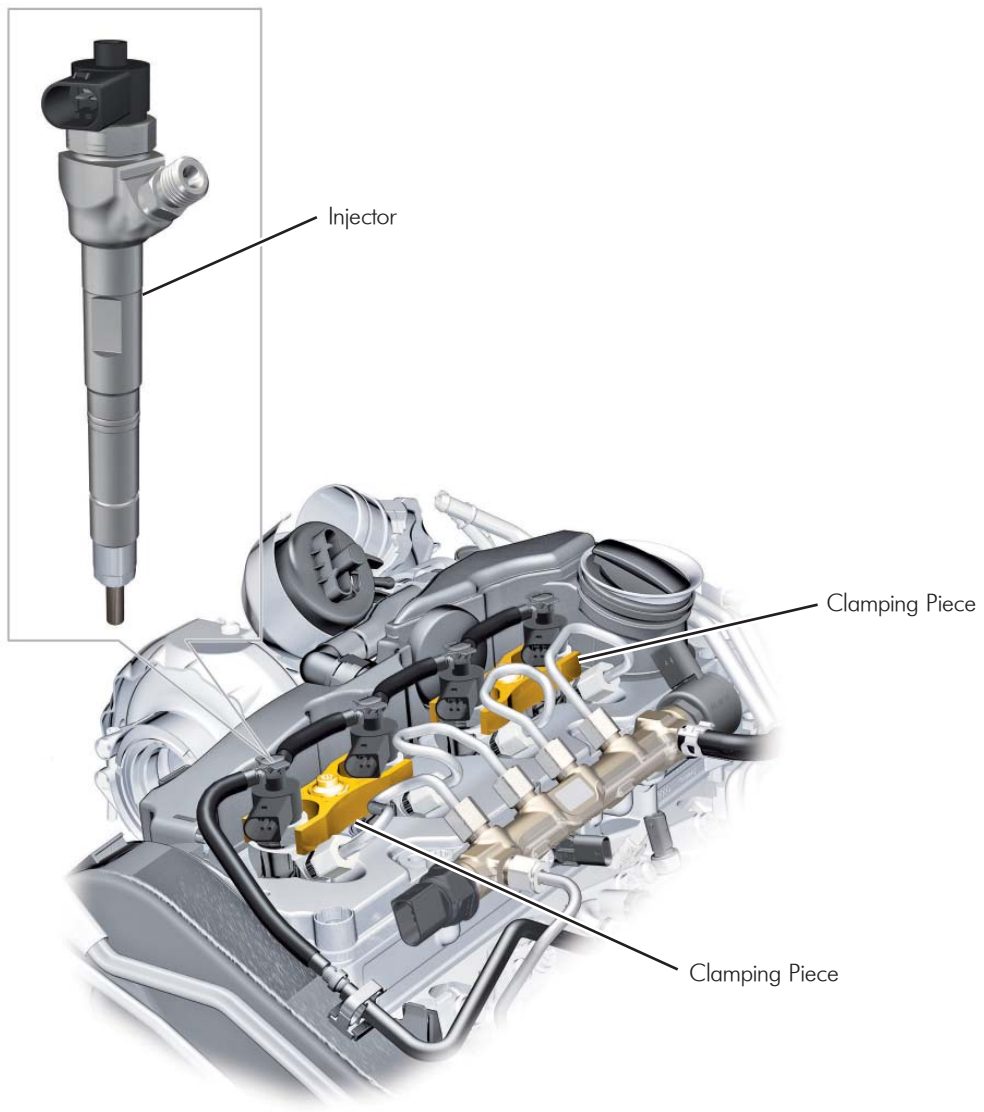



Injector in Resting Position

In its rest position, the injector is closed and the solenoid is not actuated.

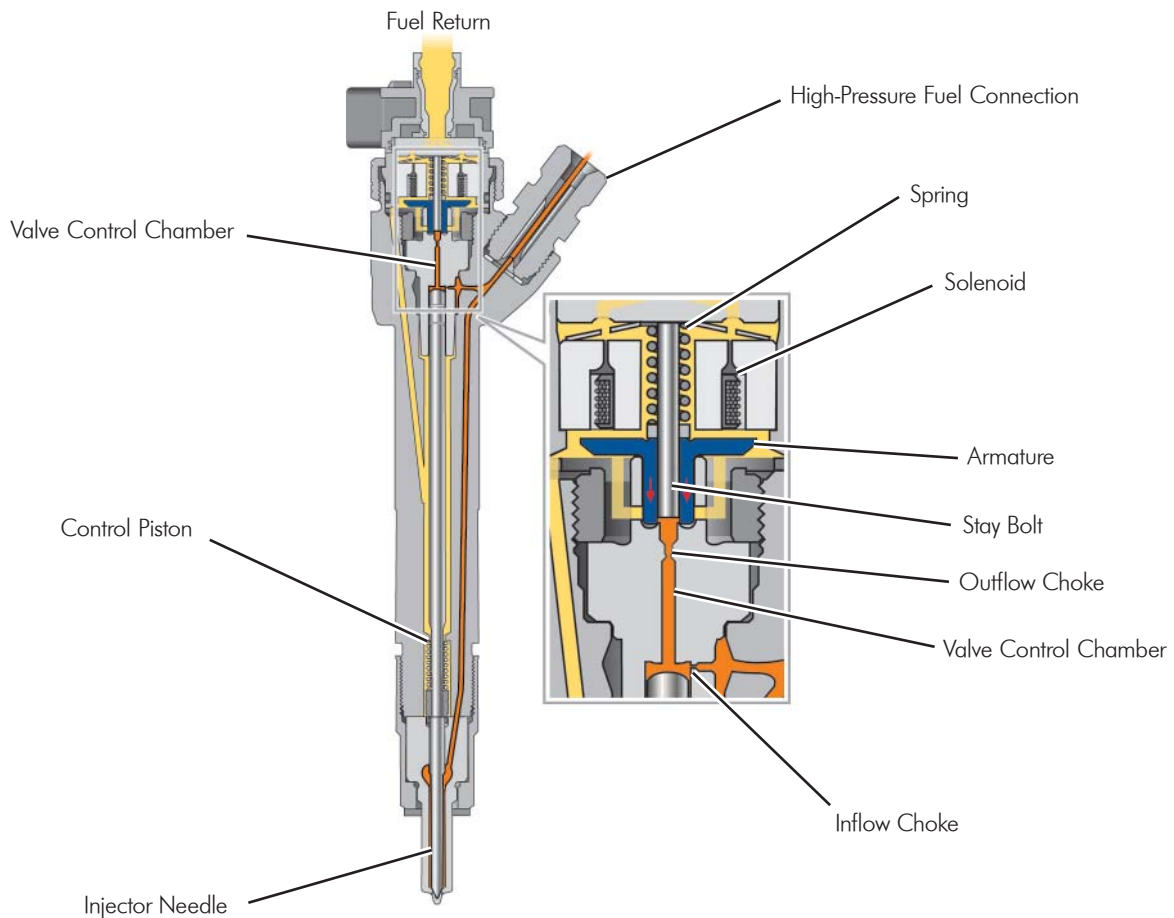
The solenoid valve armature is pushed into its seat by the force of the solenoid valve spring, which closes the passage from the valve control chamber to the fuel return. The fuel is under high pressure in the valve control chamber. Due to the larger pressure/surface ratio of the control piston surface to the injector needle, the injector needle is pushed into its seat and closes the injection nozzle.



Key

-  High Pressure
-  Return Pressure

S514_049

Engine Mechanics

Injector Closes (Start of Injection)

The solenoid is activated by the ECM to initiate the injection cycle. When the magnetic force exceeds the closing force of the solenoid valve spring, the solenoid valve armature moves upwards, opening the outflow choke. The fuel in the valve control chamber flows through the opened outflow choke into the fuel return line. The fuel pressure in the valve control chamber falls. The inflow choke prevents rapid pressure equalization between the fuel high-pressure section and the valve control chamber. The injector needle is raised by the high fuel pressure and injection begins.

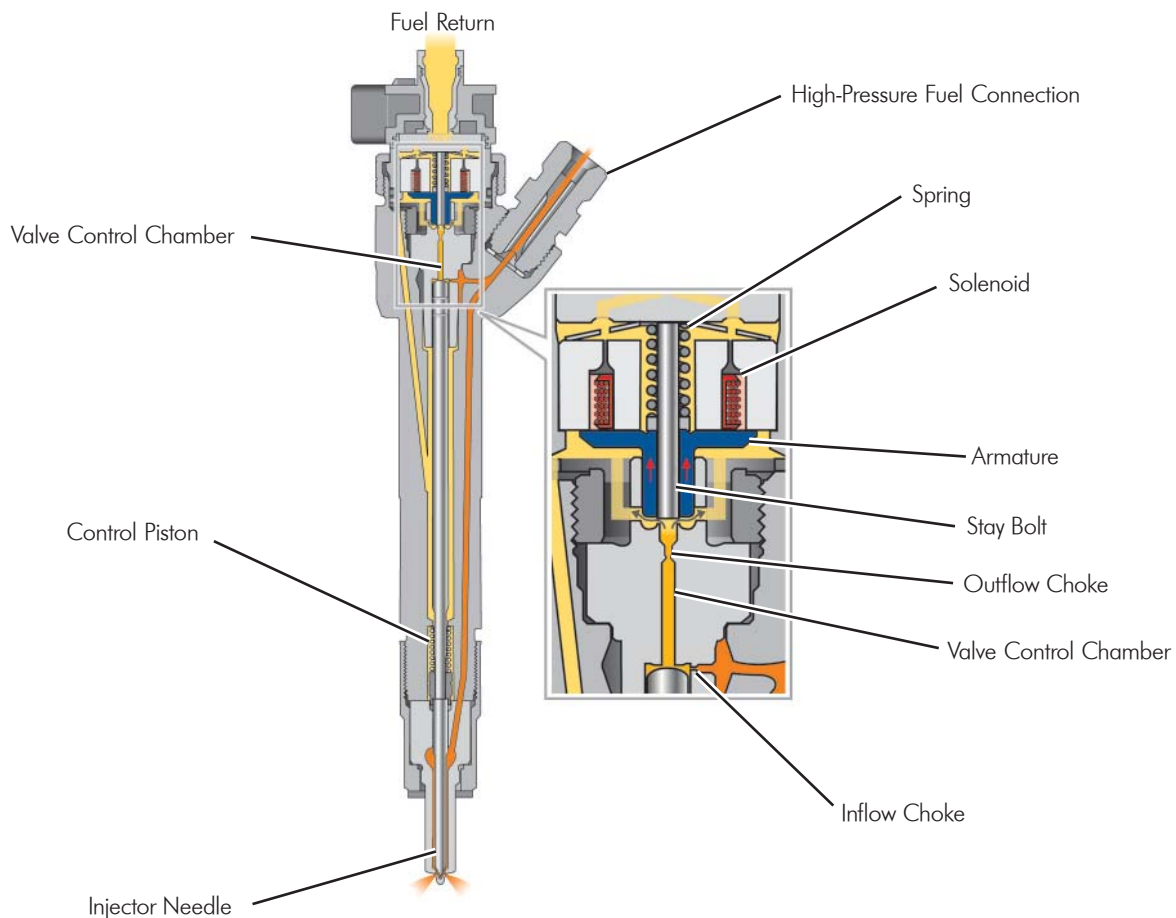

S514_050

Key

- High Pressure
- Return Pressure

Pre-Heating the Fuel Filter

When the fuel temperature is cold, warmed fuel from the high-pressure accumulator (rail) is directed into the supply line upstream of the fuel filter to prevent the fuel filter becoming clogged with crystallized paraffin.

To allow the fuel to be warmed quickly when the engine is cold, the N290 Fuel Metering Valve is regulated to supply more fuel than is required for injection to the pressure chamber of the high-pressure pump. This excess fuel is warmed when pressurized by high-pressure pump. The fuel travels from the high-pressure accumulator (rail) through the N276 Fuel Pressure Regulator Valve into the fuel filter return line, helping to warm incoming fuel.

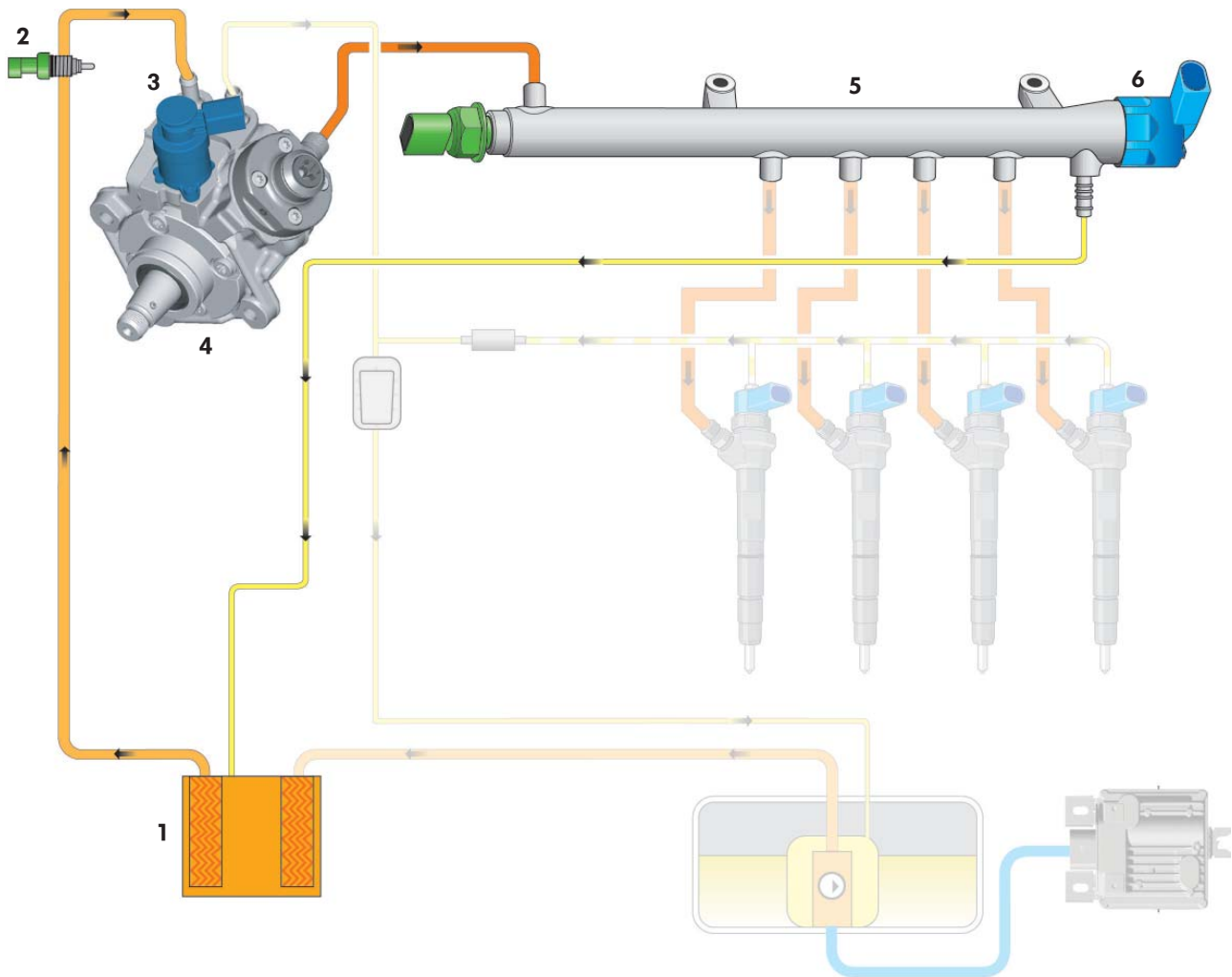

Key

- 1 Fuel Filter
- 2 G81 Fuel Temperature Sensor
- 3 N290 Fuel Metering Valve

- 4 High-Pressure Pump
- 5 High-Pressure Accumulator (Rail)
- 6 N276 Fuel Pressure Regulator Valve

S514_108

Engine Mechanics

G6 Transfer Fuel Pump

The G6 is an electrically-driven crescent pump. It is located in the GX1 Fuel Delivery Unit. Depending on the operating mode of the engine, the pump generates a pressure of 3.5 to 5 bar in the fuel system supply line.

The pump only generates the necessary pressure for the current operating situation.

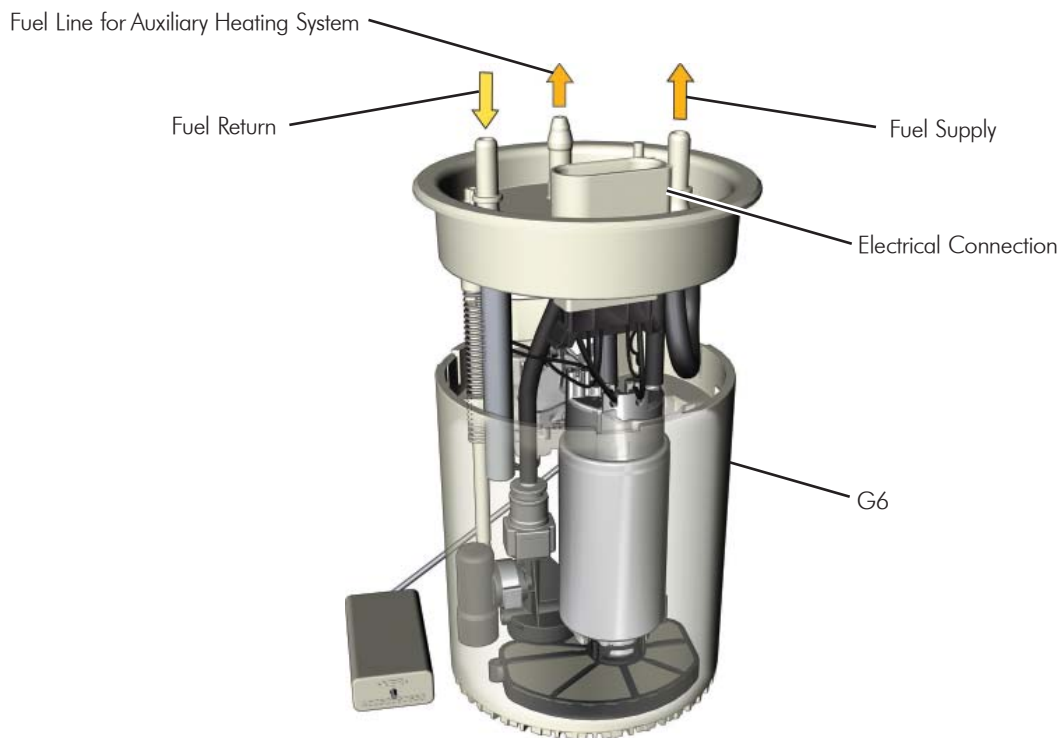

S514_030

Function

The ECM uses various signals (e.g. accelerator pedal position and fuel temperature) to calculate the current fuel demand. It then sends a PWM signal to the J538 Fuel Pump Control Module. The fuel pump control module controls the required fuel volume by running the pump faster or slower.

Effects of Failure

The engine does not run if the fuel pump fails.

G6 Transfer Fuel Pump

The electric motor for the fuel pump is an EC (electronically commutated) motor. The EC motor is a brushless, permanently excited synchronous motor. The rotor has two permanent magnet pairs and a stator with six electromagnetic coils.

Due to its brushless design and the specific functionality of the motor, there is no contact between the moving parts. This makes the motor essentially free of wear and tear with the exception of the bearings.

Design

The connection piece of the fuel pump contains the electrical connectors to the fuel pump control module and the fuel delivery connector. The pump chamber is connected to the rotor shaft.

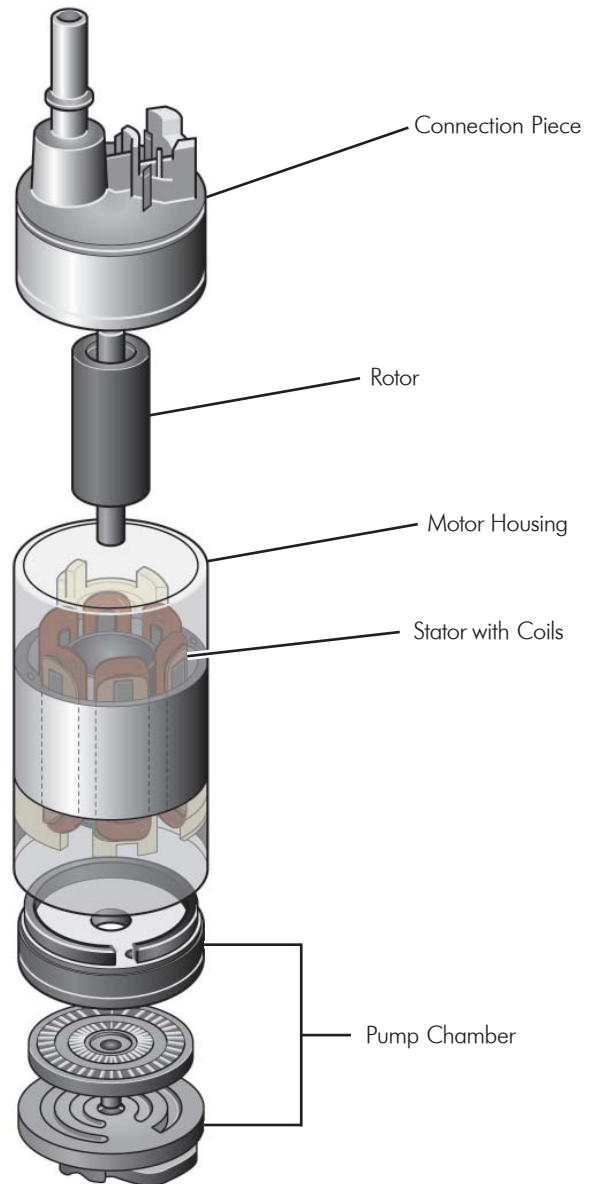

S514_031

Engine Mechanics

Fuel Pump Function

To start the rotor moving, the fuel pump control module switches the current direction of the electromagnets back and forth in phases. This switching of the current direction is known as “commutating.” The magnetic fields of the stator coils change alternately.

The stator coils are actuated so that a rotating magnetic field is generated in the stator coils. The permanent magnet pairs force the rotor continually to re-align itself and thus follow the magnetic field. This leads to the turning motion of the rotor.

The position of the rotor is detected by the fuel pump control module by an unpowered coil pair. This feedback signal is also known as a back electromotive force (EMF) signal.

Functional Principle

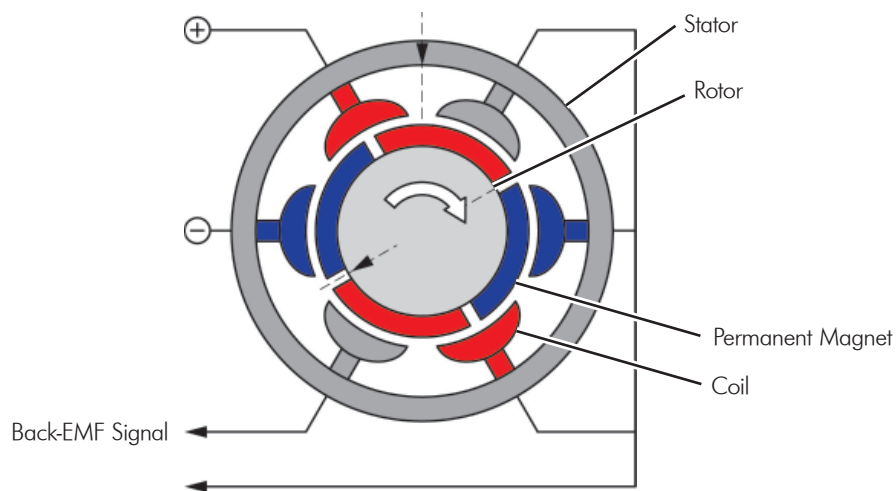

S514_032

Coil Winding Circuits

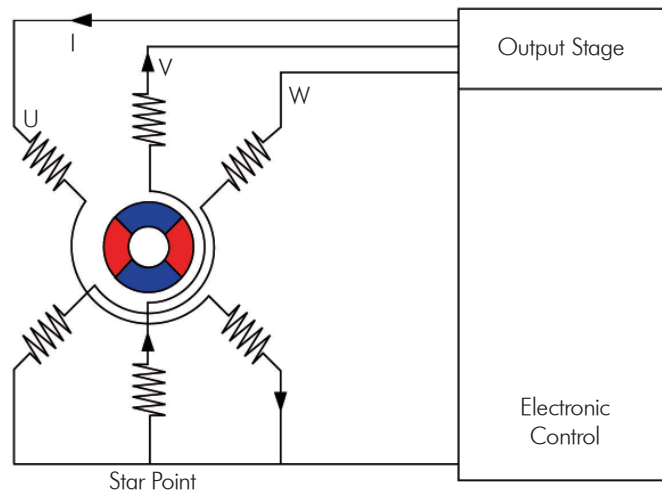

S514_033

Pulsation Damper

A pulsation damper is located near the right side of the engine. It reduces noise caused by pulsating fuel in the fuel return line.

When operating, the action of the one-piston high-pressure pump drawing fuel from the compressor produces a pressure pulsation in the low-pressure fuel area of the high-pressure pump. This causes the return line to vibrate. These vibrations can pass into the floor of the vehicle and create noise.

To reduce the pulsation in the fuel return line, a cushion of air builds in the pulsation damper when the engine is running. The air cushion absorbs the pressure pulsations in the fuel return line to reduce vibration.

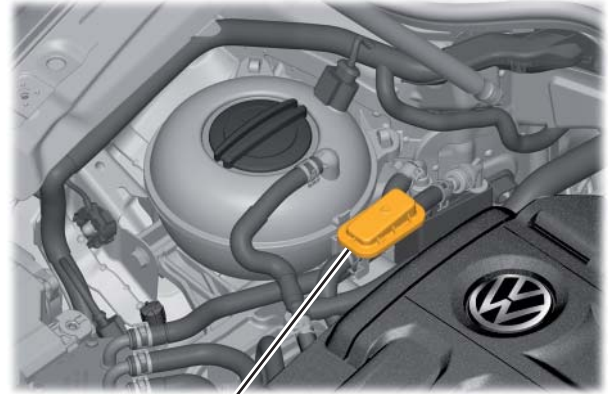

Pulsation Damper

S514_052

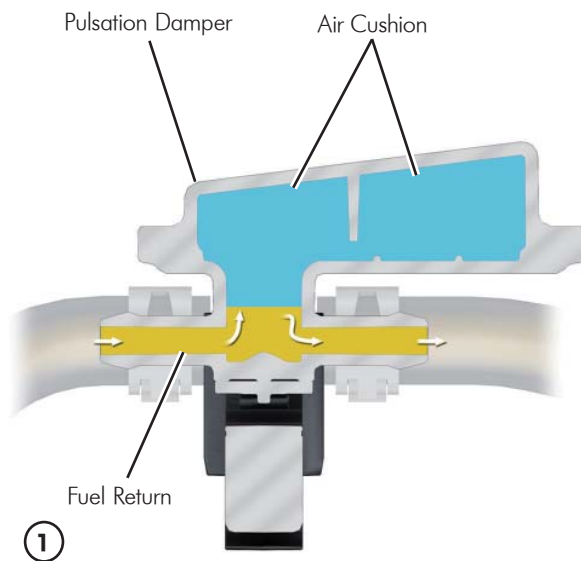

1

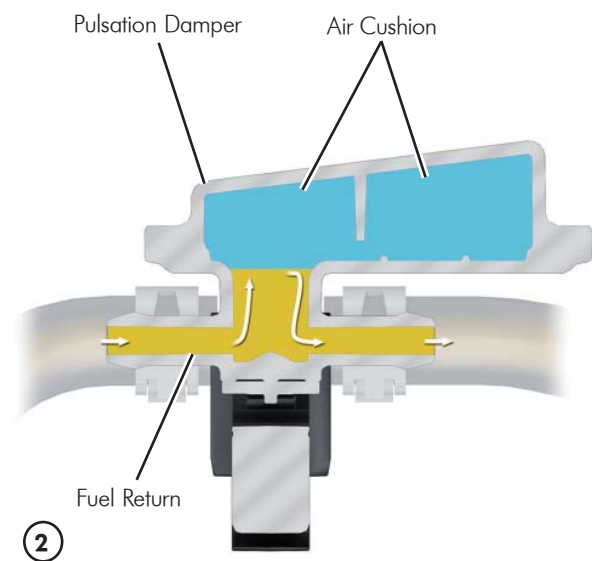

2

S514_057

S514_058

Engine Management System

Overview of the System

Sensors

- G28 Engine Speed Sensor
- G40 Camshaft Position Sensor
- G79 and G185 Accelerator Pedal Position Sensor 1 and 2
- G466 Exhaust Gas Recirculation Position Sensor 2
- F Brake Lamp Switch
- F63 Brake Pedal Switch
- G247 Fuel Pressure Sensor
- G81 Fuel Temperature Sensor
- G62 Engine Coolant Temperature Sensor
- G70 Mass Airflow Sensor
- G42 Intake Air Temperature Sensor
- G811 Charge Air Temperature Sensor after Charge Air Cooler
- G581 Charge Pressure Actuator Position Sensor
- G31 Charge Air Pressure Sensor
- G466 Exhaust Gas Recirculation Position Sensor 2
- G39 Heated Oxygen Sensor
- G235 Exhaust Gas Temperature Sensor 1
- G495 Exhaust Gas Temperature Sensor 3
- G648 Exhaust Gas Temperature Sensor 4
- G505 Differential Pressure Sensor
- G266 Oil Level Thermal Sensor
- F1 Oil Pressure Switch
- F378 Reduced Oil Pressure Switch

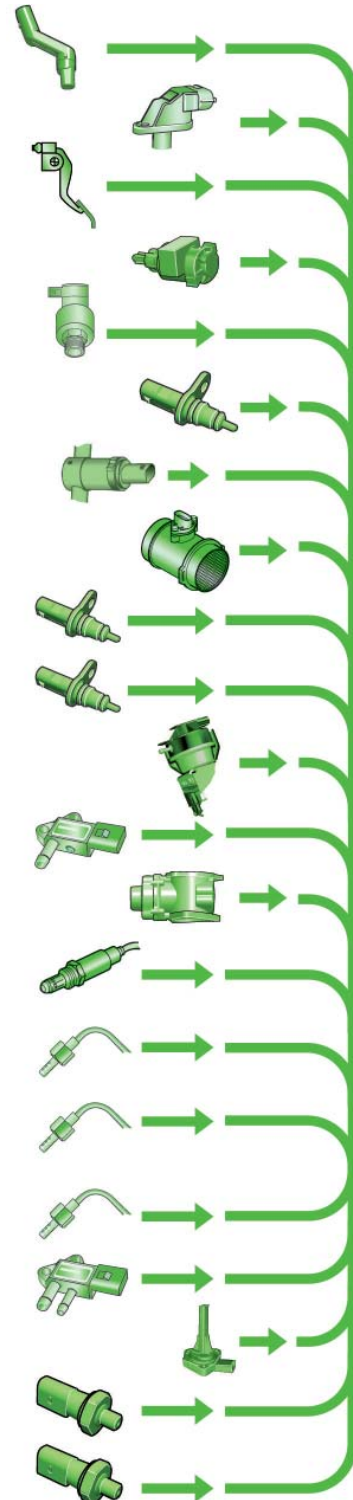

Engine Management System

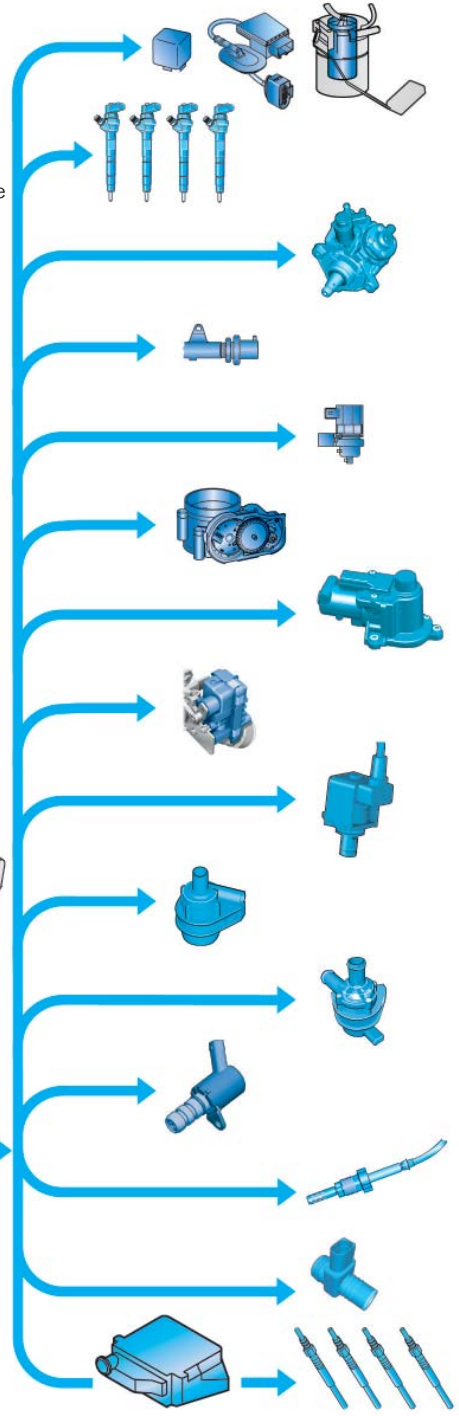
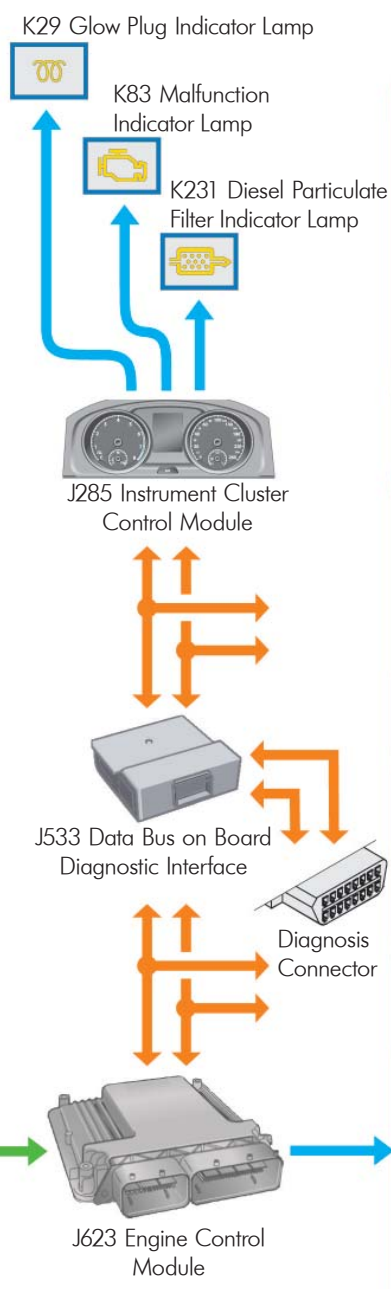

Actuators

- J17 Fuel Pump Relay
- J538 Fuel Pump Control Module
- G6 Transfer Fuel Pump
- N30, N31, N32, N33 Cylinder 1 - 4 Fuel Injectors
- N290 Fuel Metering Valve
- N276 Fuel Pressure Regulator Valve
- N75 Wastegate Bypass Regulator Valve
- J338 Throttle Valve Control Module
- V339 EGR Motor 2
- J883 Exhaust Door Control Unit
- N489 Cylinder Head Coolant Valve
- V188 Charge Air Cooling Pump
- V488 Heater Support Pump
- N428 Oil Pressure Regulation Valve
- Z19 Oxygen Sensor Heater
- N79 Positive Crankcase Ventilation Heating Element
- J179 Automatic Glow Time Control Module
- Q10, Q11, Q12, Q13 Glow Plugs 1 - 4

S514_080

Engine Management System

Air Regulation System

Ever-tightening emissions standards require enhanced air system controls. The EA288 diesel engine air regulation system is based on a model that calculates the conditions of the air system in all operational states of the engine.

All pressure figures, temperature values and mass airflows on the intake air, charge air and exhaust lines of the engine are monitored. These values are used to regulate the charge pressure, the cylinder filling, and the EGR rate. The complex air regulation system of the engine manages a large number of actuators with a limited number of sensors.

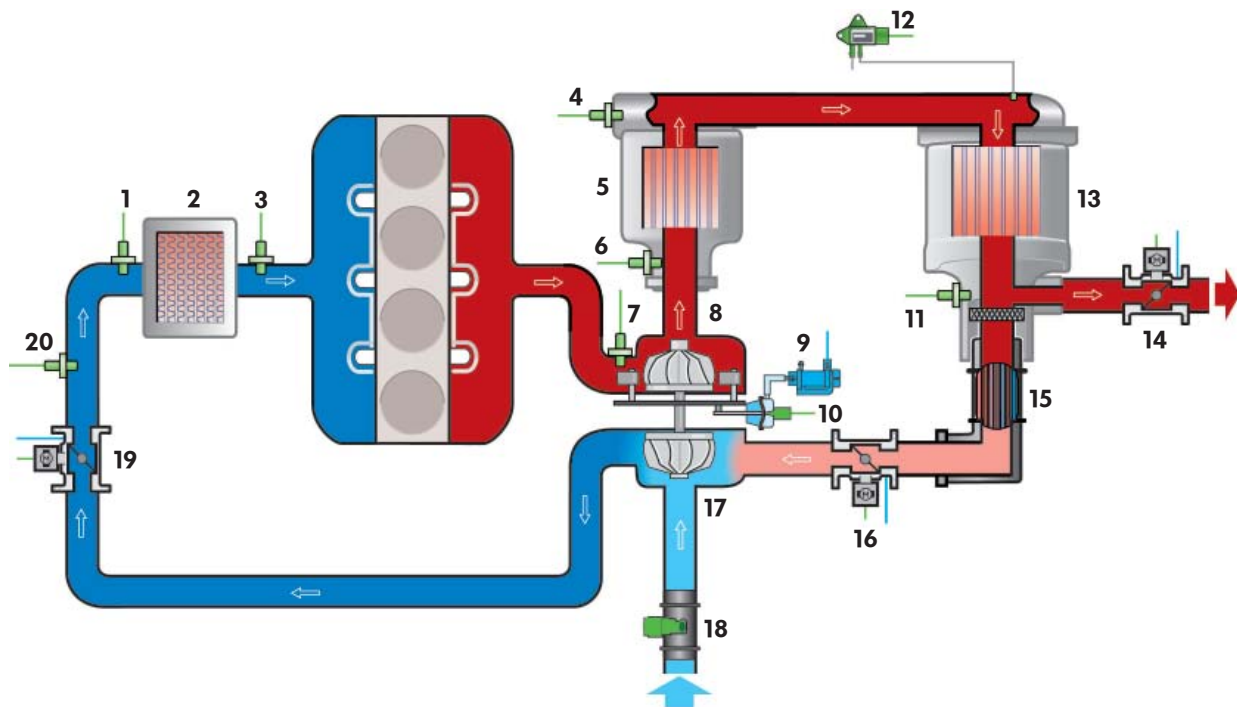

Key

- | | | | |
|----|--|----|---------------------------------------|
| 1 | G42 Intake Air Temperature Sensor | 11 | G648 Exhaust Gas Temperature Sensor 4 |
| 2 | Charge Air Cooler | 12 | G505 Differential Pressure Sensor |
| 3 | G811 Charge Air Temperature Sensor after Charge Air Cooler | 13 | Diesel Particulate Filter |
| 4 | G495 Exhaust Gas Temperature Sensor 3 | 14 | J88 Exhaust Door Control Unit3 |
| 5 | Oxidizing Catalytic Converter | 15 | Exhaust Gas Recirculation Cooler |
| 6 | G39 Heated Oxygen Sensor | 16 | V339 EGR Motor 2 |
| 7 | G235 Exhaust Gas Temperature Sensor 1 | 17 | Turbocharger Compressor |
| 8 | Exhaust Turbine with Guide Vane Adjustment | 18 | G70 Mass Airflow Sensor |
| 9 | N75 Wastegate Bypass Regulator Valve | 19 | J338 Throttle Valve Control Module |
| 10 | G581 Charge Pressure Actuator Position Sensor | 20 | G31 Charge Air Pressure Sensor |

S514_035

Engine Management System

Turbocharger

The turbocharger is integrated into an exhaust manifold. The turbocharger has adjustable guide vanes that regulate the flow of exhaust gas onto the turbine impeller. The variable vane turbocharger provides optimum charge pressure throughout the entire engine speed range. An adjustable vacuum unit has a link that adjusts the guide vanes. The vacuum is controlled by an electro-pneumatic charge pressure control valve.

The G581 Charge Pressure Actuator Position Sensor is integrated into the vacuum unit of the turbocharger. It is a position sensor that enables the ECM to determine the position of the guide vanes of the turbocharger.

The EA288 TDI engine with the BIN 5 emission standard has a low-pressure EGR system to reduce NOx emissions. The exhaust gas is removed downstream from the diesel particulate filter and is introduced back into the intake stream in front of the turbocharger compressor wheel. This provides better turbo response and higher cylinder charge pressures, particularly under partial load operation.

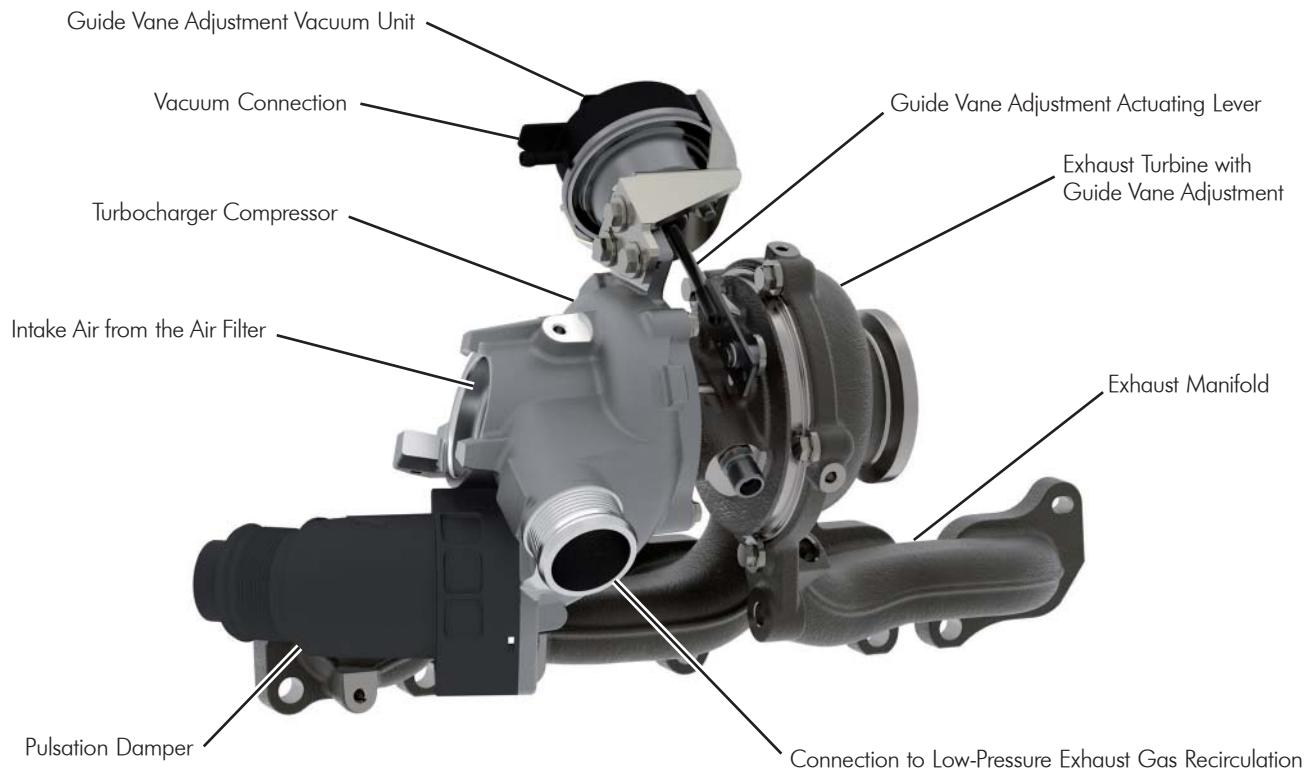

S514_084

The pulsation dampener is placed in the passage going to the charge air cooler; it reduces unwanted noises in the charge air system.

Engine Management System

Charge Pressure Control

The charge pressure control regulates the quantity of air that is compressed by the turbocharger.

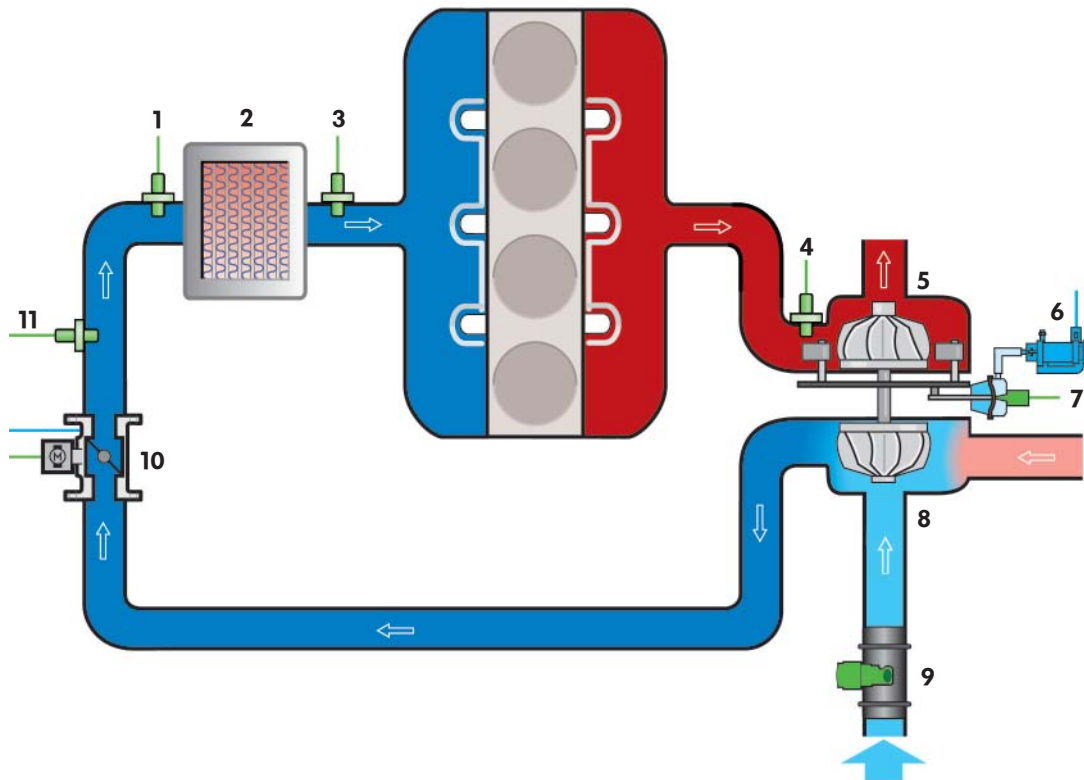

Key

- | | | | |
|---|--|----|---|
| 1 | G42 Intake Air Temperature Sensor | 7 | G581 Charge Pressure Actuator Position Sensor |
| 2 | Charge Air Cooler | 8 | Turbocharger Compressor |
| 3 | G811 Charge Air Temperature Sensor after Charge Air Cooler | 9 | G70 Mass Airflow Sensor |
| 4 | G235 Exhaust Gas Temperature Sensor 1 | 10 | J338 Throttle Valve Control Module |
| 5 | Exhaust Turbine with Guide Vane Adjustment | 11 | G31 Charge Air Pressure Sensor |
| 6 | N75 Wastegate Bypass Regulator Valve | | |

SS14_107

N75 Wastegate Bypass Regulator Valve

The ECM uses a duty cycle to activate the charge pressure control solenoid valve. The charge pressure control solenoid valve switches the control pressure in the turbocharger vacuum unit.

Effects of Failure

The turbocharger guide vanes are moved to a steep working angle by a spring located in the vacuum unit. This position is referred to as the emergency operation position. When the vanes are in the steep working angle, only a low charge pressure is available. The engine has less power and active regeneration of the diesel particulate filter is not possible.

Engine Management System

G31 Charge Pressure Sensor

Signal Use

The G31 measures the air pressure in the intake manifold. The ECM uses the charge pressure sensor signal to regulate the charge pressure.

Effects of Failure

There is no substitute function in the event of signal failure. Charge air pressure regulation is shut off and there is a significant reduction in engine output. The particulate filter cannot be actively regenerated if the charge pressure sensor fails.

G581 Charge Pressure Actuator Position Sensor

Signal Use

The position sensor for the charge pressure positioner provides the ECM with the current position of the turbocharger guide vanes. The ECM uses this signal with the signal from the charge pressure sensor G31 to regulate the charge pressure.

Effects of Failure

If the sensor fails, the signal of the charge air pressure sensor and engine speed determine the position of the guide vanes.

G42 Intake Air Temperature Sensor

Signal Use

The intake air temperature sensor signal is used by the ECM to regulate the charge pressure. Because temperature affects the density of the charge air, the ECM uses the intake air temperature signal as a correction value.

Effects of Failure

In the event of sensor failure, the ECM uses a fixed substitute value for calculation purposes.

Ambient Air Pressure Sensor

The ambient air pressure sensor is installed in the ECM. It measures the ambient air pressure. As the density of the intake air decreases as altitude increases, the ambient air pressure is used as a correction value for charge pressure control.

Engine Management System

J338 Throttle Valve Control Module

The throttle valve module is installed in the intake tract before the charge air cooler. The position of the throttle valve is used to regulate the air pressure and the intake air quantity in the intake manifold.

An electric motor in the throttle valve module operates the throttle valve via gears (G186 EPC Throttle Drive). Adjustment of the throttle valve is infinite and is adapted to the engine operating situation. During regeneration of the diesel particulate filter, the throttle valve regulates the quantity of intake air and oxygen supply.

The valve is closed when the engine is turned off to stop air from entering the engine. This results in the engine shutting down softly.

Effects of Failure

If the throttle valve module fails, correct regulation of the intake manifold pressure is not possible. There is no active regeneration of the diesel particulate filter.

G187 EPC Throttle Drive Angle Sensor 1

The G187 is integrated into J338. The sensors detect the current position of the throttle valve.

Signal Use

The ECM uses the G187 signal to identify the current position of the throttle valve. This information is necessary to regulate the intake manifold pressure and regeneration of the particulate filter.

Effects of Failure

If the sensor fails, the engine is run in emergency mode with reduced power. No active regeneration of the diesel particulate filter takes place.

Engine Management System

Charge Air Cooling

Air-to-liquid cooling is used for cooling the charged air, allowing for more accurate control of charge air temperatures. The intake manifold temperature can be adapted to the engine operating mode. The charge air system also has a smaller volume compared to air-cooled charge air cooling.

The turbocharger compresses a smaller air volume and the charge pressure is reached faster.

To cool the charge air, the charge air cooling pump is actuated by the ECM. It draws the coolant from the charge air cooling radiator and pumps it to the charge air cooler.

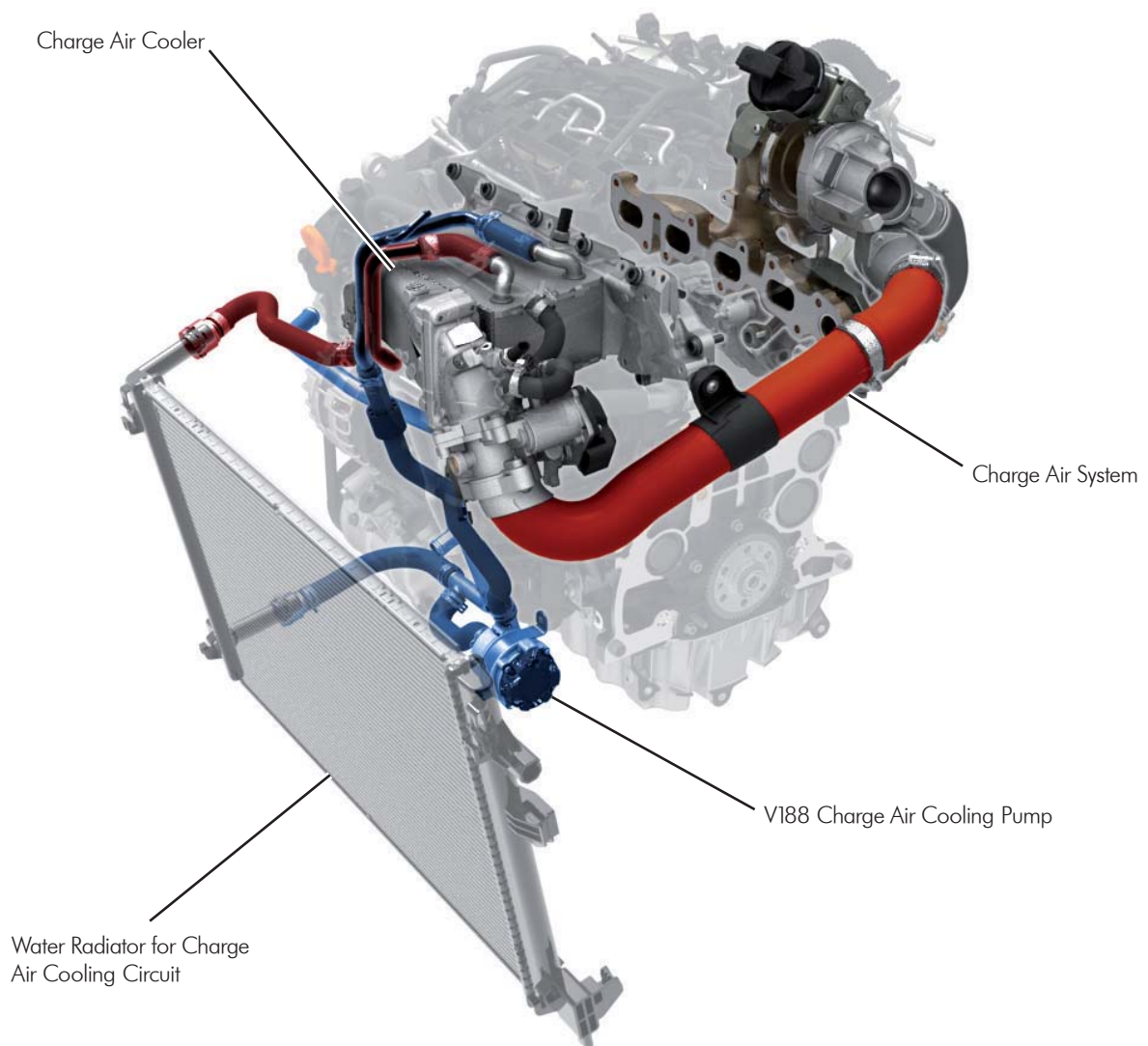

Engine Management System

Charge Air Cooler

The charge air cooler is welded to the “conduit” and the “connecting flange,” that forms the intake manifold. The radiator for the charge air cooler contains coolant ribs with W-shaped fins, a cover/base and side plates, and the coolant connections. All components of the charge air cooler are made of aluminum.

The charge air cooler is a heat exchanger. The warm air in the intake manifold is conducted through the fins to the coolant ribs that are immersed in coolant. The coolant is then pumped to the radiator for the charge air cooling circuit.

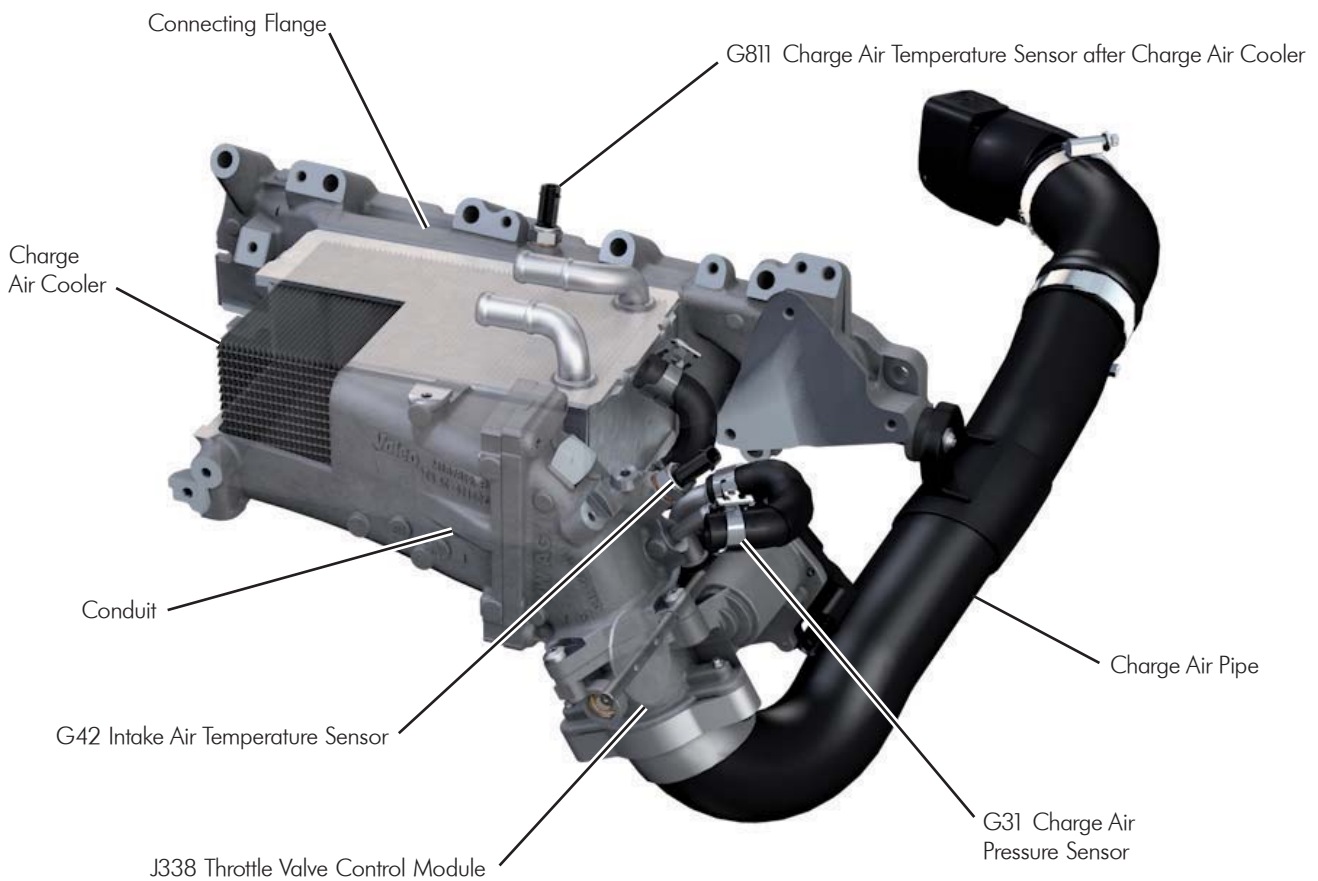

SS14_061

Intake Manifold Temperature Regulation

The V188 Charge Air Cooling Pump is actuated by the ECM to regulate intake manifold temperature. The duty cycle for actuating the pump depends on the air temperature measured after the charge air cooler and the map in the ECM.

Engine Management System

G811 Charge Air Temperature Sensor after Charge Air Cooler

Signal Use

The signal from the G811:

- Calculates the necessary duty cycle for actuating the charge air cooling pump that regulates intake manifold temperature
- Protects components. If the air temperature in the intake manifold exceeds a critical value, engine power is reduced

Effects of Failure

In the event of sensor failure, the ECM uses a fixed value for calculation purposes.

G42 Intake Air Temperature Sensor

Signal Use

During charge air cooling, the signal from the intake air temperature sensor is used by the ECM to monitor the efficiency of the charge air cooler. The ECM compares air temperature before and after the charge air cooler.

Effects of Failure

If the sensor fails, the ECM uses a fixed value for calculation purposes.

V188 Charge Air Cooling Pump

Usage

The charge air cooling pump is actuated by the ECM with a PWM signal. It draws the coolant from the radiator for charge air cooling and pumps it to the charge air cooler.

Effects of Failure

If the pump fails, a DTC is set in the ECM memory and the K83 Malfunction Indicator Lamp illuminates. If the intake manifold temperature exceeds a critical value, engine output is reduced to protect components.

Engine Management System

Exhaust Gas Recirculation (EGR)

EGR returns part of the exhaust gases to the combustion chamber to reduce nitrous oxide emissions. The reduction in the oxygen concentration of the fuel/air mixture from this process slows combustion, which leads to a reduction in the peak combustion temperature, and reduces nitrogen oxide emissions.

There are currently two system concepts for external EGR in diesel engines: the high-pressure EGR system and the low-pressure EGR system. The main difference between the two systems is the location of where the recirculated exhaust is removed from the exhaust gas stream and where the exhaust is reintroduced to the intake air.

High Pressure Exhaust Gas Recirculation (EGR)

Previous Volkswagen diesel engines have had a high-pressure EGR system. In this system, the exhaust gas is diverted from the exhaust manifold before the turbocharger turbine and added to the intake air stream before the intake manifold. The recirculation of the exhaust depends on the difference of pressure between the exhaust side and the intake side. If required, the difference in pressure can be regulated by the throttle valve control module.

A smaller throttle opening on the intake side results in high EGR rates. As the EGR rate increases, the exhaust mass flow before the turbocharger turbine drops. As a result, the turbocharger responds slower and the charge pressure needed for optimum output cannot be obtained.

Functional Diagram

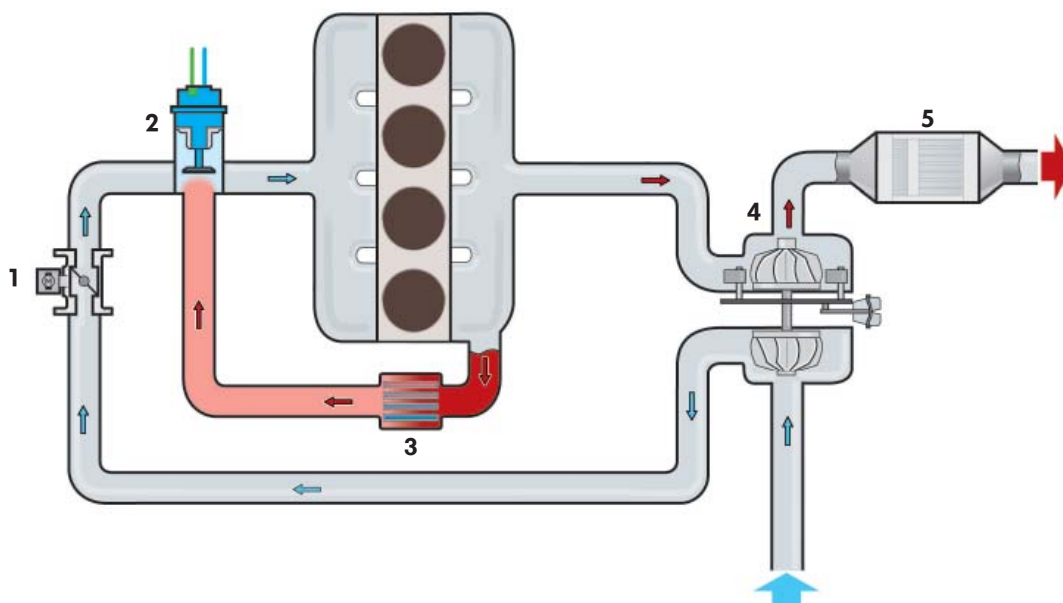

Key

- | | | | |
|---|---|---|---------------------------|
| 1 | J338 Throttle Valve Control Module | 4 | Turbocharger |
| 2 | N18 EGR Vacuum Regulator Solenoid Valve | 5 | Diesel Particulate Filter |
| 3 | Exhaust Gas Recirculation Cooler | | |

S514_075

Engine Management System

Low-Pressure Exhaust Gas Recirculation

This system removes the exhaust behind the diesel particulate filter and directs it through the EGR cooler into the intake air flow directly in front of the turbocharger.

Compared to high-pressure exhaust gas recirculation system, the low-pressure EGR system:

- Exhaust gases are cooler and free of particles
- Retains the entire exhaust mass flow in front of the turbocharger turbine. The turbocharger responds better, particularly under part-load. This allows for higher charge pressures
- Has no soot accumulation in the EGR cooler

Functional Diagram

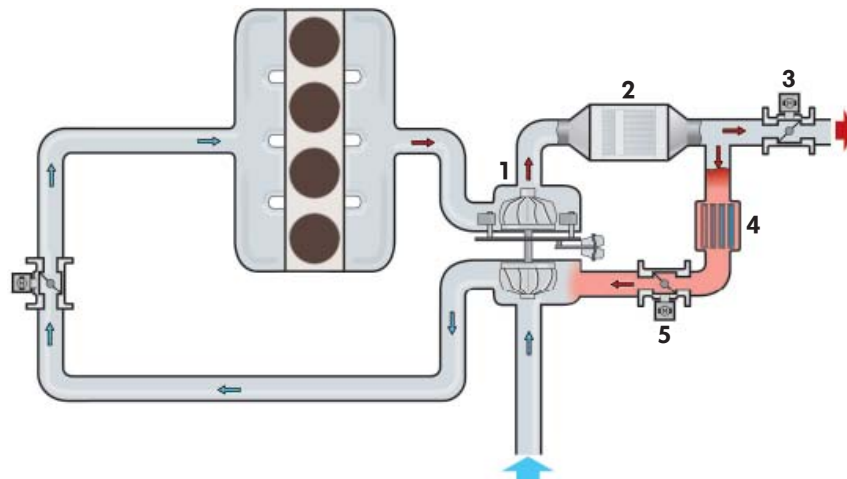

Key

1. Turbocharger
2. Diesel Particulate Filter
3. J883 Exhaust Door Control Unit

4. Exhaust Gas Recirculation Cooler
5. V339 EGR Motor 2

S514_076

Regulation of Exhaust Gas Recirculation

The EGR control module adjusts the EGR control motor to regulate the amount of exhaust gas in the low-pressure EGR system.

The EGR amount is based on a map, specific for each vehicle type.

Engine Management System

Exhaust Gas Recirculation Module

The EGR module consists of the EGR cooler and the V339 EGR Motor 2. The EGR module is located between the diesel particulate filter and the compressor side of the turbocharger. By installing it close to the engine and giving it a compact design, flow losses in the EGR system are kept to a minimum.

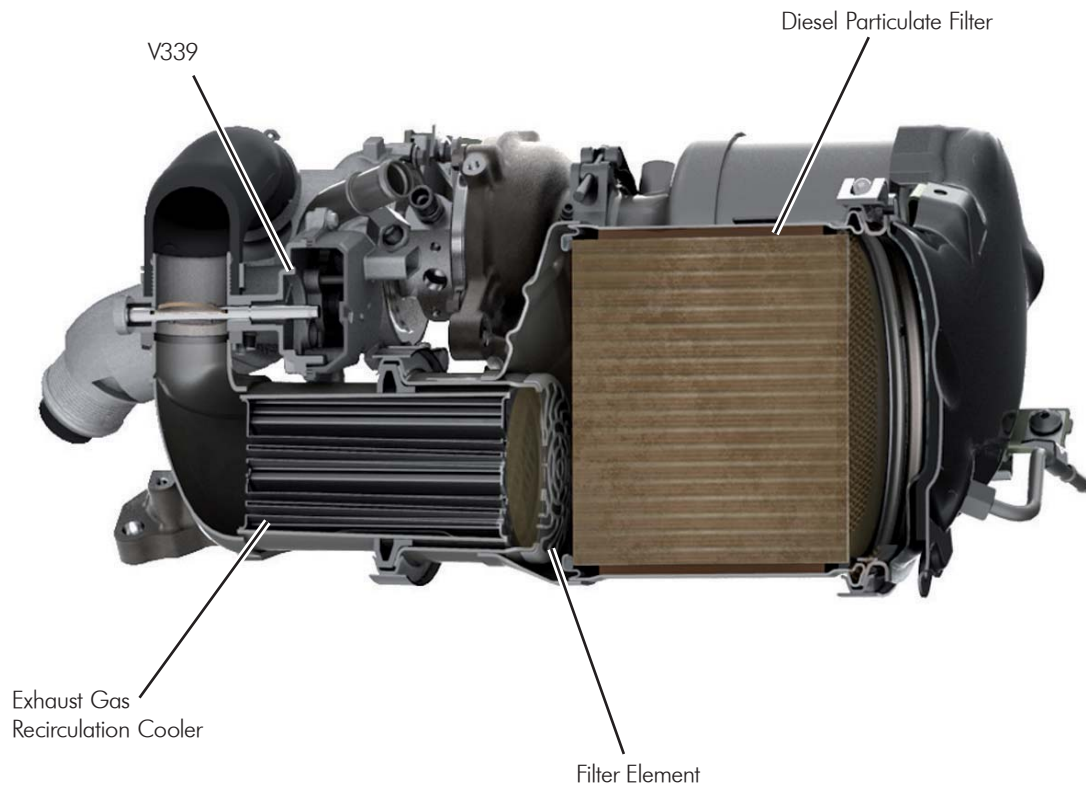

Exhaust Gas Recirculation Cooler

All recirculated exhaust gases are guided through the EGR cooler. By cooling the exhaust gases, a larger quantity of inert exhaust gases can be added to the intake air, reducing the combustion temperature in the cylinder.

The components in the charge air system are also protected from high exhaust gas temperatures.

Filter Element

A filter element made of stainless steel fabric is located in the diesel particulate filter housing. The filter element prevents any particles of dirt remaining after combustion from entering the turbocharger from the exhaust system.

S514_037

Engine Management System

V339 EGR Motor 2

The EGR control motor is actuated by the ECM using a PWM signal. It controls the throttle value in the EGR system. The position of the throttle valve, in combination with the position of the exhaust flap in the exhaust flap control unit, creates a difference in pressure between the exhaust system and the intake connecting pipe.

The difference in pressure regulates the quantity of exhaust being recirculated. The larger quantity of recirculated exhaust gases, the greater the difference in pressure. Since a high engine load results in a greater difference in pressure, the EGR rate in this operating mode is regulated by the EGR control motor. The exhaust flap remains open.

Effects of Failure

If the EGR control motor fails, the throttle valve of the EGR system is closed by a spring. No EGR is taking place.

G466 Exhaust Gas Recirculation Position Sensor 2

Signal Use

The EGR potentiometer 2 is integrated into the EGR control motor. The signal is used to determine the position of the EGR control motor. This information helps the ECM calculate and regulate the volume of EGR.

Effects of Failure

If the signal from the EGR potentiometer 2 fails, EGR is deactivated. The EGR control motor is no longer actuated by the ECM and the throttle valve of the EGR system is closed by a spring.

Engine Management System

J883 Exhaust Door Control Unit

The exhaust flap control unit has a throttle valve with an electric motor drive. It is located in the exhaust system after the diesel particulate filter. The exhaust gas flow can be slowed by the exhaust flap control unit which helps regulate EGR. The exhaust flap control unit is actuated by the ECM with a PWM signal.

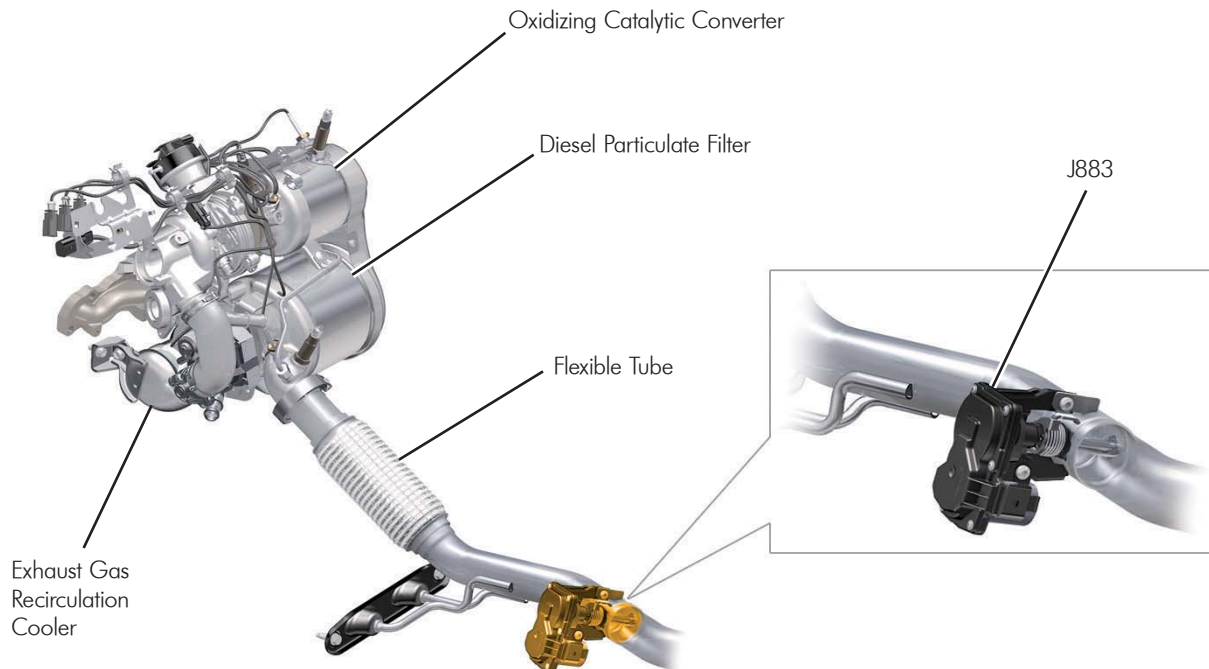

S514_062

Function

Natural variable low-pressure EGR operation occurs when there is sufficient pressure difference in between the turbocharger intake and the particulate filter outlet. When the pressure difference is not substantial enough, the exhaust flap is used to increase the exhaust pressures.

The exhaust flap can raise the exhaust gas pressure in front of the flap to about 10 mbar higher than the exhaust gas pressure after the exhaust flap.

This overpressure creates a pressure difference that allows for EGR operation in the entire engine map range.

Effects of Failure

If the exhaust flap control unit fails, the exhaust flap is moved to the "Open" position by a return spring. No EGR occurs.

Engine Management System

Exhaust Purification System

The TDI exhaust purification system has an oxidizing catalytic converter and a diesel particulate filter. These components are integrated into a single module. This close arrangement allows the oxidizing catalytic converter and the diesel particulate filter to heat up quickly, and the operating temperatures of the catalytic converter can be reached faster.

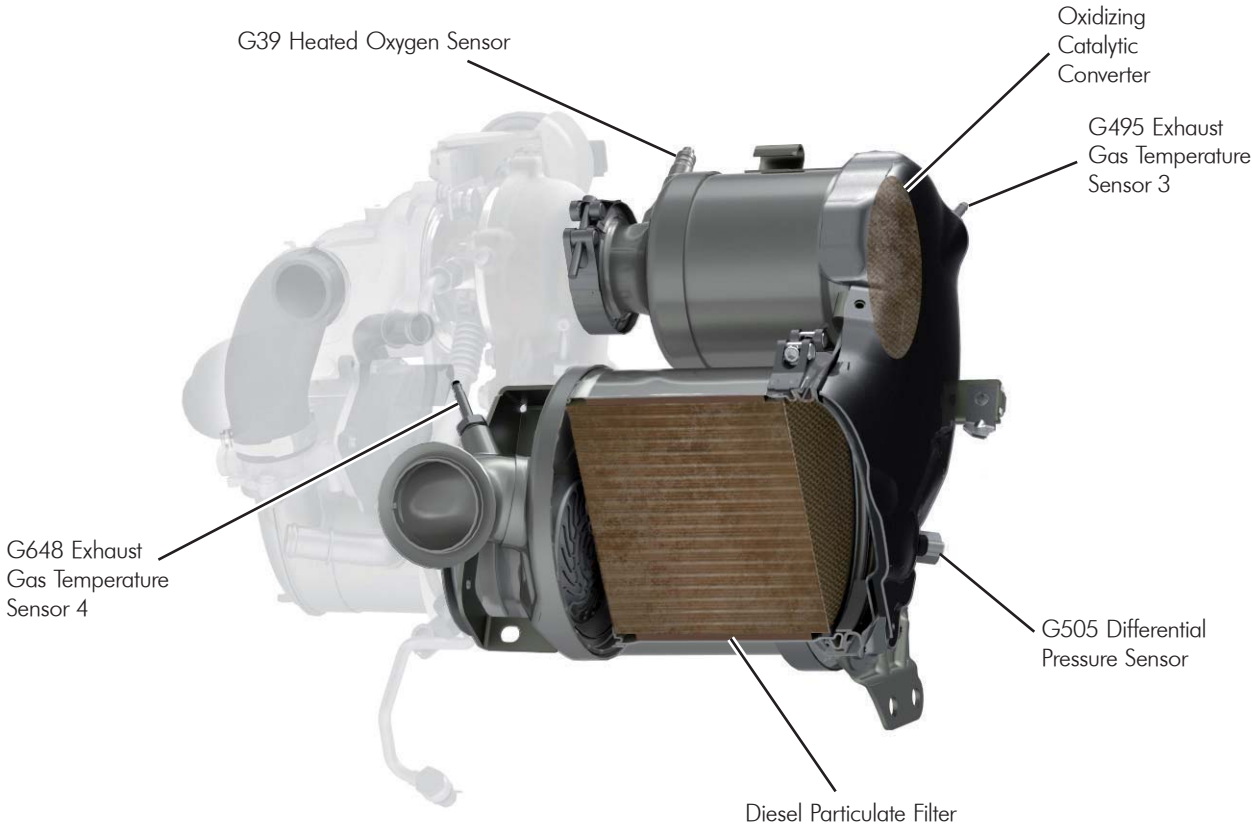

S514_085

Engine Management System

Compensation Elements

The exhaust purification module is attached to the engine block and cylinder head at four places by compensation elements.

The compensation elements are designed to keep the module in place while reducing the stress from the movement of the engine.

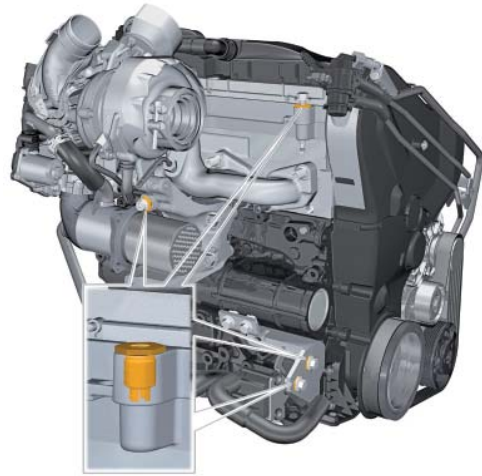

S514_054

Function

The compensation element has an internal and external thread. The external thread is a left-hand thread. The internal thread is a right hand thread.

1. First, the compensation element is screwed into place.
2. When the securing bolt is screwed into compensation element, the compensation element turns due to the friction on the tabs.
3. Because of the external left-hand thread, the compensation element turns in the opposite direction when the securing bolt is tightened.
4. This moves the compensating element up, removing the play between exhaust purification module and the engine.



Carefully follow the information and notes in the Service Information when installing and removing the exhaust purification module.

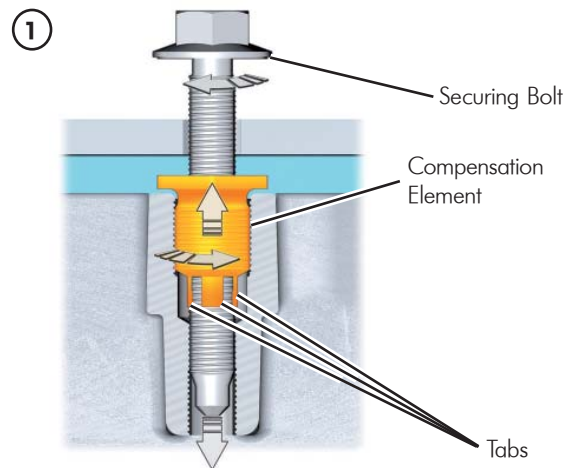

S514_055a

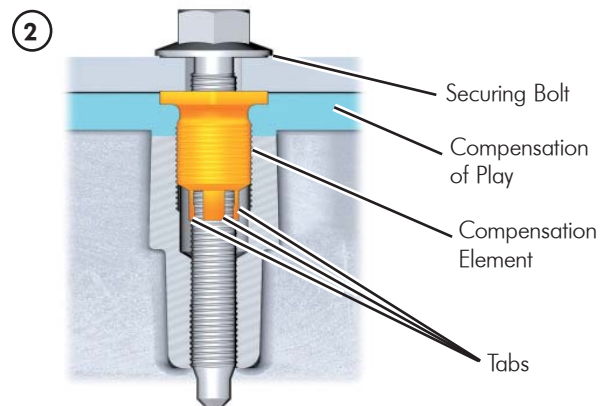

S514_101

Oxidizing Catalytic Converter

The oxidizing catalytic converters substrate material is made of metal oxides that allow the converter to reach operating temperature quicker. The substrate layer has coatings of platinum and palladium. These precious metals are used as catalysts for hydrocarbons and carbon monoxide.

Function

The catalytic coating of the oxidizing catalytic converter converts a large part of the hydrocarbons and the carbon monoxide into steam and carbon dioxide.

Diesel Particulate Filter

The diesel particulate filter consists of a honeycomb-shaped ceramic body that has been coated with aluminum titanate or silicon carbide. The ceramic body contains many small channels that are alternately opened and closed. This structure results in inlet and outlet channels that are separated by filter walls. The filter walls are porous and coated with a substrate of metal oxide, such as aluminium oxide. This substrate features a layer of the precious metals platinum and palladium. This layer functions as a catalytic converter.

Function

The exhaust gas, which contains soot, flows through the intake channels porous filter walls. Unlike the gaseous components of the exhaust gas, the soot particles are retained in the intake channels.

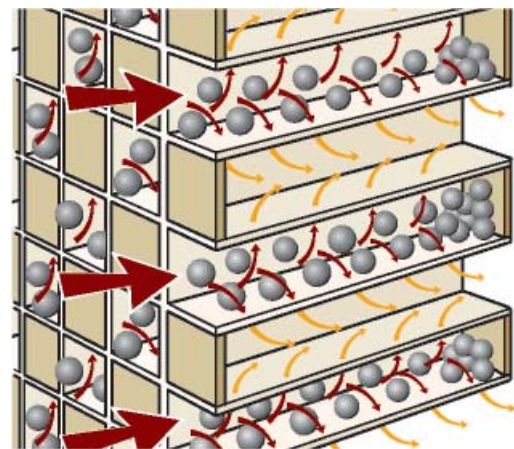

_089

Engine Management System

Regeneration

To prevent the particulate filter from becoming plugged with soot particles it must regenerate regularly. During the regeneration process, the soot particles which have collected in the particulate filter are burned (oxidized).

The regeneration of the particulate filter takes place in the following stages:

- Passive regeneration
- Heat-up phase
- Active regeneration
- Regeneration trip by customer
- Service regeneration

Passive Regeneration

During passive regeneration, the soot particles are continuously combusted without engine management system intervention. This usually happens when the engine is subjected to high loads, such as during expressway driving. This causes exhaust gas temperatures of 350 °C to 500 °C. The soot particles react with the nitrogen dioxide and are converted to carbon dioxide.

Heat-Up Phase

If the oxidizing catalytic converter and the particulate filter are cold on engine start, the ECM triggers up to two additional secondary injections immediately after the main injection. This brings the oxidizing catalytic converter and the particulate filter up to operating temperature as quickly as possible.

The fuel injected during these targeted post-injections burns in the cylinder and increases the temperature level of the combustion. The heat that it generates passes through the exhaust flow to the oxidizing catalytic converter and the particulate filter, and heats them up.

The heating phase is complete as soon as the operating temperature of the oxidizing catalytic converter and the particulate filter has been attained for a certain length of time.

Engine Management System

Active Regeneration

In most of the engine operating ranges, the exhaust gas temperatures are too low for passive regeneration. Since soot particles are not burned, the soot accumulates in the filter. As soon as a specific level of soot has accumulated in the filter, active regeneration is induced by the engine management system. The soot particles are burned at an exhaust gas temperature of 550 °C to 650 °C and form carbon dioxide.

Active Regeneration Function

The soot load of the particulate filter is calculated by two pre-programmed load models in the ECM.

One load model is determined from the user driving style and values from the exhaust gas temperature sensor and lambda probe signals.

Another soot load model is the flow resistance of the particulate filter. It is calculated using data from the G450 Exhaust Pressure Sensor 1, the exhaust gas temperature sensors, and the calculated exhaust mass flow from the ECM.

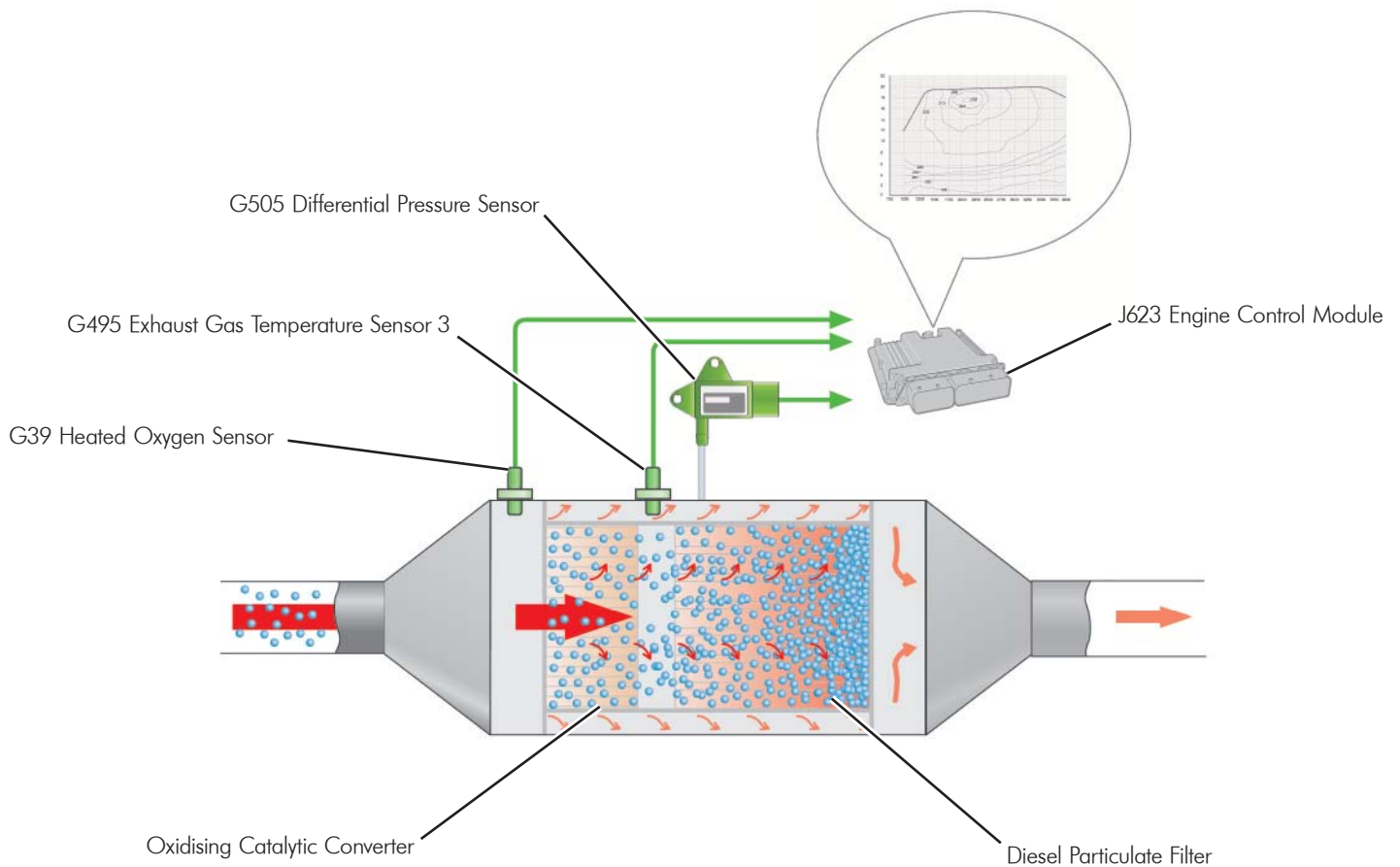

5514_090

Engine Management System

Actions to Raise the Exhaust Temperature During Active Regeneration:

- The intake air supply is regulated by the throttle valve module
- Shortly after a “retarded” main injection, one or two post-injections are introduced to increase the combustion temperature
- Further post-injection is introduced long after main injection. The injected fuel does not combust in the cylinder, but evaporates in the combustion chamber
- The uncombusted hydrocarbons contained in the fuel vapor are oxidized in the oxidizing catalytic converter. The heat generated during this process passes to the particulate filter and increases the exhaust gas temperature upstream of the particulate filter to approximately 620 °C
- For the calculation of the injection quantity for the retarded post-injection, the ECM uses the signal from G495 Exhaust Gas Temperature Sensor 3
- The charge pressure is adapted so that during regeneration torque does not change noticeably for the driver

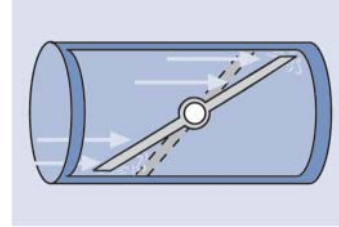

S514_091

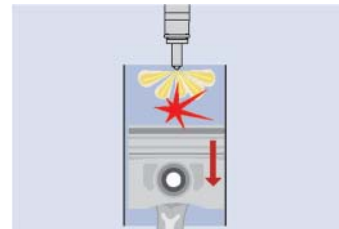

S514_093

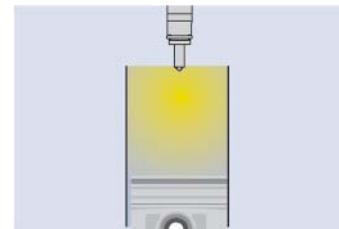

S514_094

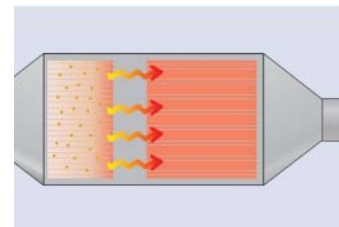

S514_095

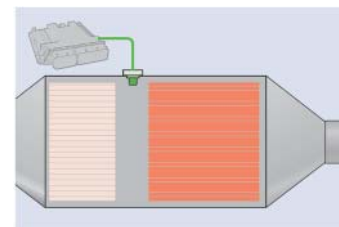

S514_096

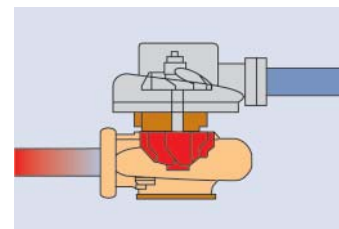

S514_097

Engine Management System

Regeneration Drive Cycle by Customer

When driving only extremely short trips, the exhaust temperatures are not high enough to regenerate the filter. If the load condition of the diesel particulate filter reaches the upper limit, the diesel particulate filter warning lamp in the dash panel insert lights up. This signal instructs the driver to perform a regeneration drive cycle.

The vehicle must be driven for a short period at a steady speed without turning off the engine. This creates a high exhaust gas temperature. Successful regeneration can occur.



For detailed information on driving behavior when the diesel particulate filter warning lamp illuminates, please refer to the owner's manual.

Service Regeneration

If the regeneration trip was not successful and the load state of the diesel particulate filter has reached 40 grams, the glow plug warning lamp illuminates and the diesel particulate filter warning lamp both illuminate.

The text "Engine malfunction - workshop" appears in the MFI and the driver is requested to seek the next dealership service department. To avoid damage to the particulate filter, the ECM will not attempt active regeneration of the diesel particulate filter. The particulate filter can only be regenerated in a workshop using the vehicle diagnostic tester.



With load condition of 45 grams, a service regeneration is no longer possible, because the risk of destroying the filter is too high. The filter must be replaced.





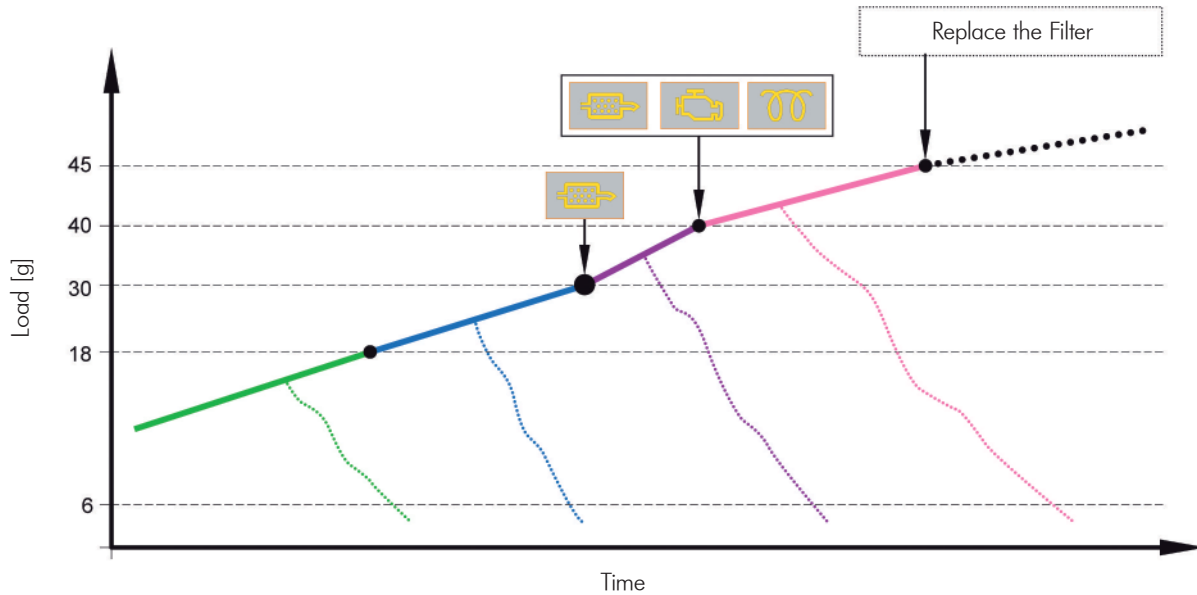







Engine Management System

Regeneration Stages of the EA288 TDI Engine



S514_098

Key

-      For example: Increase in Soot Load
-     For example: Procedure for Successful Regeneration in the Respective Step:
-  Passive Regeneration
-  Active Regeneration
-  Regeneration Trip by Customer
-  Service Regeneration

“Mileage Regeneration”

The ECM automatically initiates an active regeneration if there has been no regeneration – or no successful regeneration – in the last 465 miles, regardless of the load condition of the diesel particulate filter.

“Mileage regeneration” is used as an additional safety system to keep the load condition of the diesel particulate filter low.



During engine operation, a small amount of engine oil is always burned. Part of the burned engine oil is collected as ash in the particulate filter. This “oil ash” cannot be removed, even during active regeneration. For efficient operation, the ash limit should be checked with the diagnostic tester during an inspection. If this limit value is exceeded, the diesel particulate filter must be replaced.

Engine Management System

Glow Plug System

The rapid-start glow plug system is used on these engines. This system allows the diesel engine to be started immediately in all conditions. The starting procedure is comparable to that of a gasoline engine.

Advantages of the Glow Plug System

- Engine start comparable to a gas engine at temperatures down to -24 °C.
- Extremely short heating time. Within two seconds, the glow plug temperatures reach up to 1000 °C.
- Controllable temperatures for preglow and afterglow phases
- Self-diagnostic ability
- Part of the on-board diagnosis glow plug system

System Overview

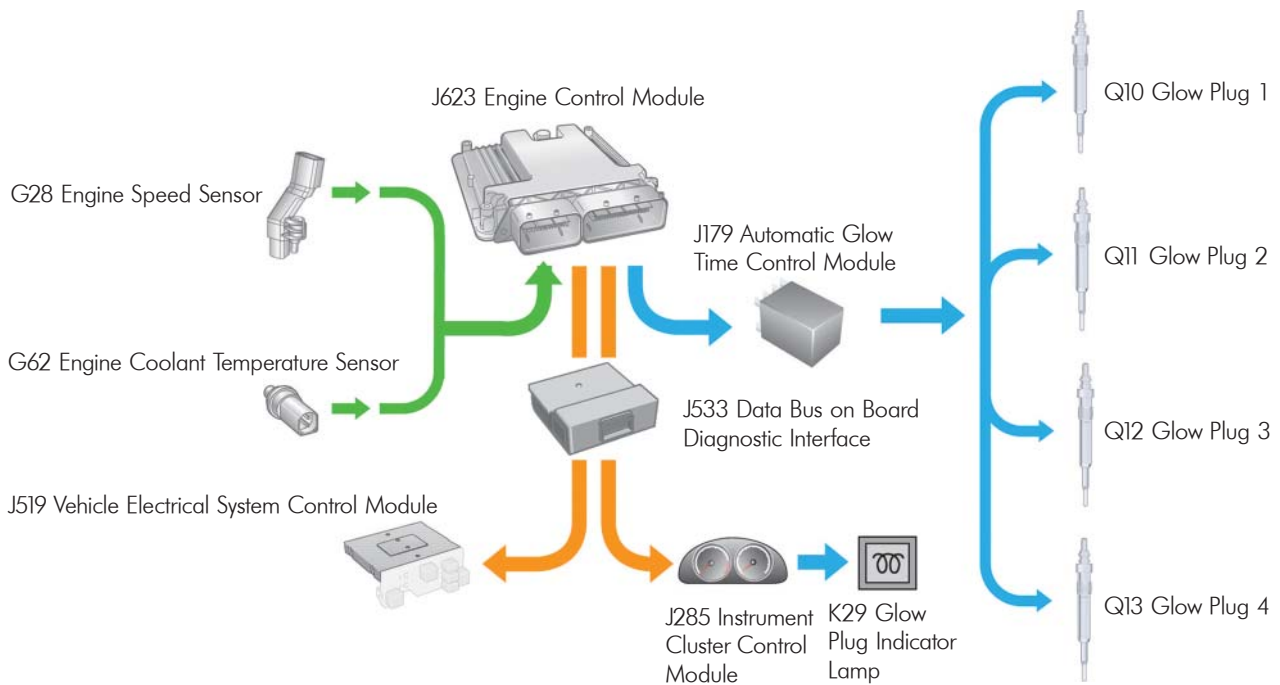

Engine Management System

Function

Pre-glowing

The J179 Automatic Glow Time Control Module activates the steel glow plugs using phase-shifting. The voltage at the individual glow plugs is adjusted by the duty cycle of the PWM pulses. For rapid starting at an exterior temperature of less than 24 °C, there is a maximum voltage of 11.5 V. This provides glow plug temperatures of over 1000 °C within a short time (maximum 2 seconds).

Phase-Shifted Activation of the Glow Plugs

To relieve the load on the onboard supply voltage during the glow phases, the glow plugs are actuated in a phase-shifted manner. The falling signal actuates the next glow plug.

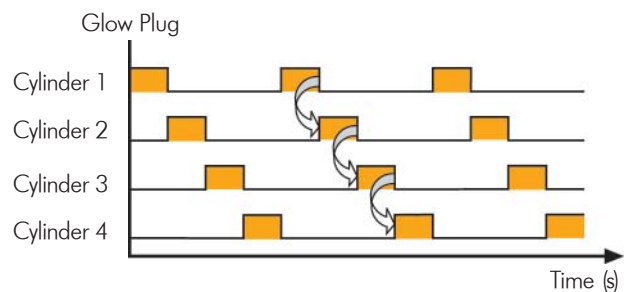

S514_040

Post-Start Glowing

Post-start glowing helps reduce hydrocarbon emissions and combustion noises during the warm-up phase.

For post-start glowing, the switch-on time of the onboard supply voltage is adjusted in the PWM duty cycle to ensure that there is an effective voltage of 4.4 V. Post-start glowing lasts a maximum of 5 minutes after starting the engine or until coolant temperature reaches 24 °C.

Particulate Reduction System

The particulate reduction system is made of thin, corrugated sheets of steel with paddle-shaped structures. There are layers of fleece with metallic fibers between them.

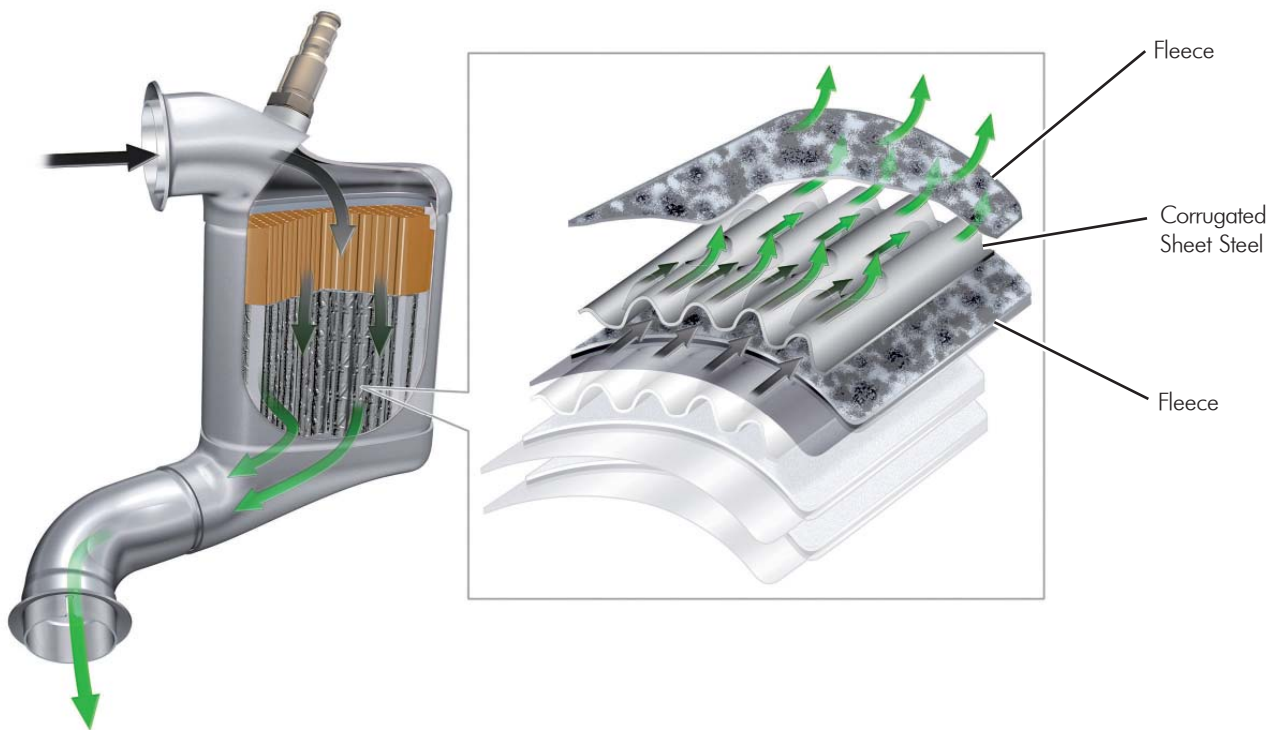

S514_088

Function

The paddle-shaped structures of the corrugated sheets of steel direct part of the exhaust gas stream through the metallic fleece. This fleece separates the soot particles and filters them out of the exhaust gas stream. The system is called open because it does not force the exhaust gas stream through the fleece. It can also flow unfiltered past the diverting paddles.

The particulate reduction system is only regenerated passively. During passive regeneration, the soot particles caught on the metallic fleece are continuously combusted without engine management system intervention. In this case, the soot particles are converted to carbon dioxide by a reaction with nitrogen dioxide within an exhaust gas temperature range of 350 °C to 500 °C.

Engine Management System

Exhaust Gas Recirculation Cooler

The EGR cooler has a bypass valve that directs the recirculated exhaust gases through the cooler or past the cooler, depending on the operating temperature. The bypass valve is switched electro-pneumatically by the N345 EGR Cooler Switch-Over Valve. The EGR cooler changeover valve is controlled by the ECM..

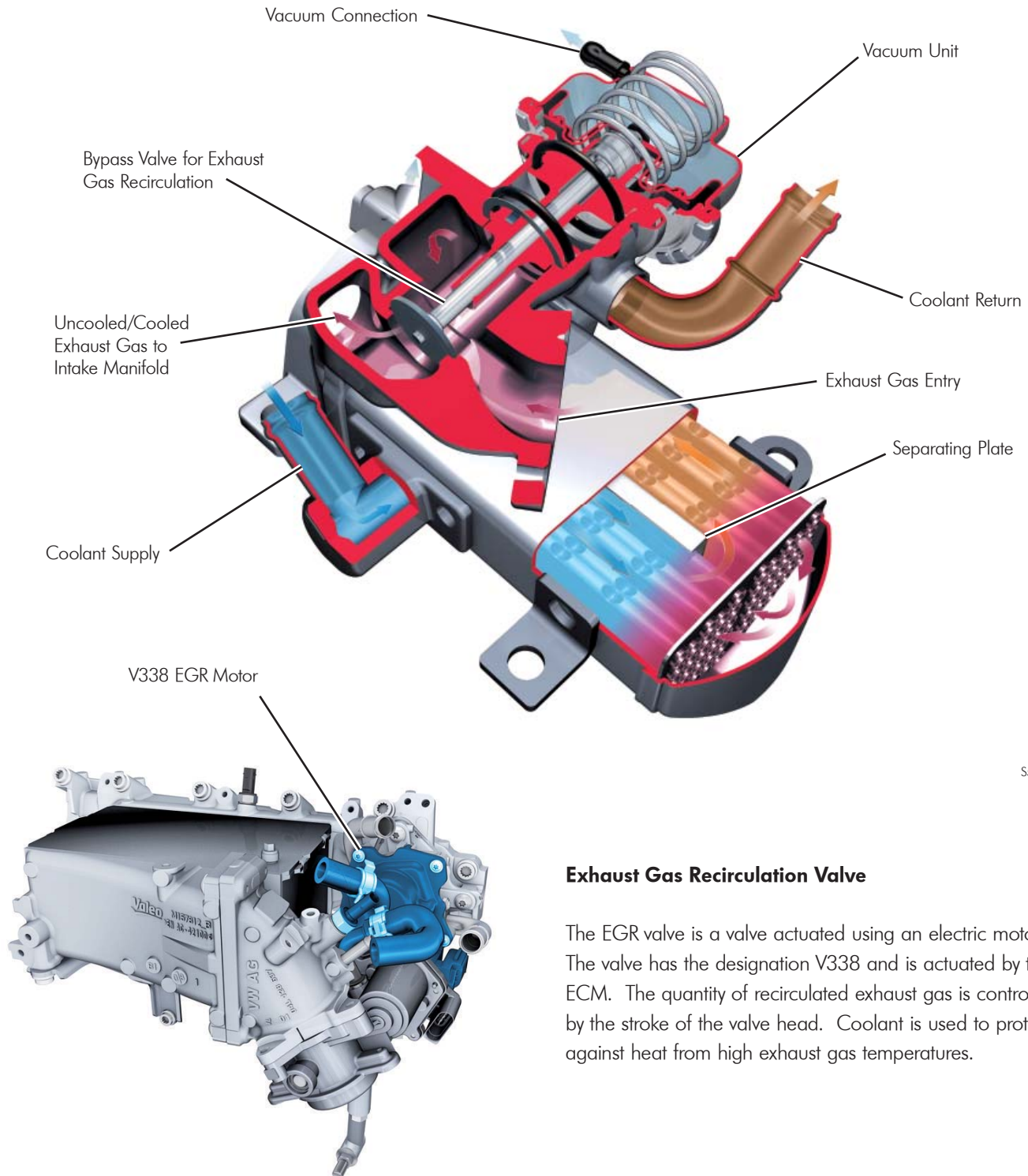



S514_036



Exhaust Gas Recirculation Valve

The EGR valve is a valve actuated using an electric motor. The valve has the designation V338 and is actuated by the ECM. The quantity of recirculated exhaust gas is controlled by the stroke of the valve head. Coolant is used to protect against heat from high exhaust gas temperatures.

Special Tools and Workshop Equipment

Description	Tool	Usage
T10172/11 Adapter	 <p>S514_063</p>	Used with camshaft sprocket counterholder
T10489 Puller	 <p>S514_064</p>	Used to dismantle the high-pressure pump hub.
T10490 Crankshaft Stop	 <p>S514_065</p>	Secures crankshaft stop during valve timing adjustments.

Service

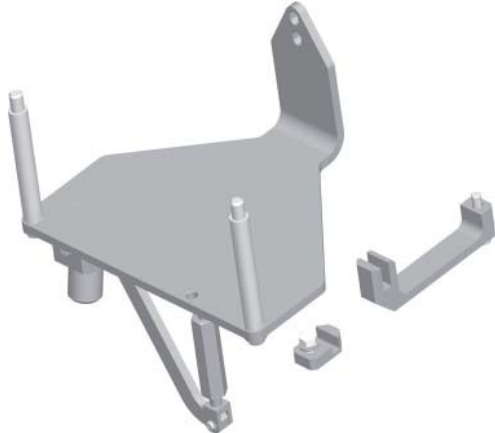
Description	Tool	Usage
T10491 Socket SW22	 <p style="text-align: right; font-size: small;">S514_066</p>	Removes and installs the lambda probe.
T10492 Locking Pin	 <p style="text-align: right; font-size: small;">S514_067</p>	High-pressure pump wheel lock.
T10493 Assembly Tool	 <p style="text-align: right; font-size: small;">S514_068</p>	Assembly tool for camshaft oil seals.
T10497 Engine Bracket	 <p style="text-align: right; font-size: small;">S514_070</p>	Used with engine and transmission jack V.A.G. 1383 A to remove and install engine

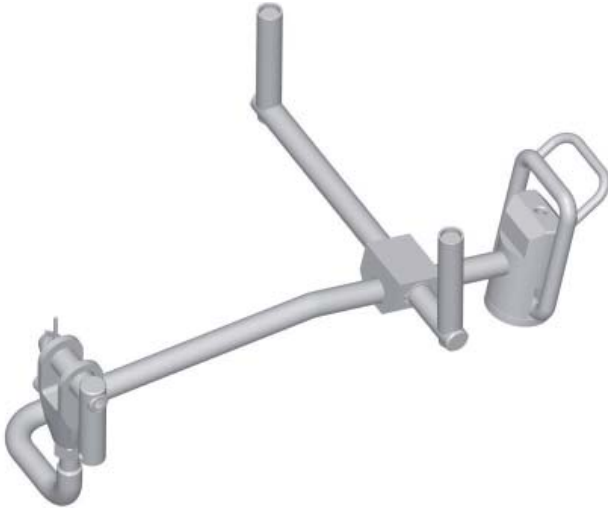
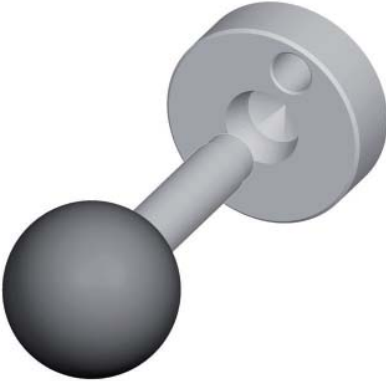
Description	Tool	Usage
T10501 Socket XZN 10	 <small>S514_077</small>	Socket for removal and installation of the intake manifold.
T10511 Assembly Aid	 <small>S514_078</small>	Aids in removal and installation of the exhaust purification module.
T10512 Calibration Tool	 <small>S514_069</small>	Adjusts compensation elements when installing the exhaust purification module.

Notes

Knowledge Assessment

An on-line Knowledge Assessment (exam) is available for this Self-Study Program.

The Knowledge Assessment may or may not be required for Certification.

You can find this Knowledge Assessment at:

www.vwwebservice.com

For Assistance, please call:

Volkswagen Academy

Certification Program Headquarters

1-877-791-4838

(8:00 a.m. to 8:00 p.m. EST)

Or, E-mail:

concierge@volkswagenacademy.com



Volkswagen Group of America
2200 Ferdinand Porsche Drive
Herndon, VA 20171
February 2014

