

SUPERLIGHT CHASSIS – BOLTED

This chassis design is for a lightweight teardrop trailer – for general information, visit the teardrop forum at: <http://www.mikenchell.com/forums>

This design is provided in good faith but its use cannot be controlled and the builder must satisfy her/himself that it is suitable for the use to which it will be put.

There are two limitations on the use of this chassis, listed below:

Body

This design of chassis with a minimal frame is only suitable for use with a well-constructed lightweight body that is self-supporting.

The main requirement is that all parts of the body are joined together by continuous glued joints that are approximately as strong as the parts they join. It is unlikely (but not impossible) that joints that are only screwed together will be strong enough.

Weight

The A-frame in 2"x2"x1/8" angle passes the Australian trailer design rules for strength for gross trailer weights up to 320 pounds for a 42" front overhang (see plan view drawing), or up to 380 pounds for a front overhang of 36" (ie, vertical trailer front).

The Australian rules apply to utility trailers. For a teardrop trailer with reasonable balance and hitch weight, it would appear that a gross weight of twice this weight can be reasonably used, so 640 pounds for a 42" front overhang and 760 pounds for a 36" overhang.

This strength of frame is used in commercially-built teardrops with gross weights up to 1200 pounds.

Assembly

The frame members are joined to each other and to the axle by 1/2" bolts. The frame is joined to the body by 3/8" bolts – a maximum of one 3/8" bolt hole is acceptable in each A-frame member as it passes under the front of the body.

The safest way to assemble the front of the A-frame members is to bolt the parts together using the front bolt hole between the A-frame members and coupler mount. The bolt holes in the back end of the A-frame members should be spaced at 46 1/4" centre to centre for the 4ft wide chassis and 58 1/4" for the 5ft wide chassis. The rear bolt hole can then be drilled in all three parts, 2 1/2" behind the front hole for the 4ft wide chassis and 2" behind the front hole for the 5ft wide chassis.

Axle

The design has been prepared using a Dexter #8 axle. Axles by other manufacturers may be equally suitable, but some details (such as mounting holes) will need to be altered.

The dimensions for the axle are:

Nominal chassis width	4ft	5ft
Width over hubfaces	58 1/4"	70 1/4"
Width over mounting brackets	48 1/4"	60 1/4"

The axle should be specified with 'reversed orientation' mounting brackets (flanges inward). See drawings for start angle options.

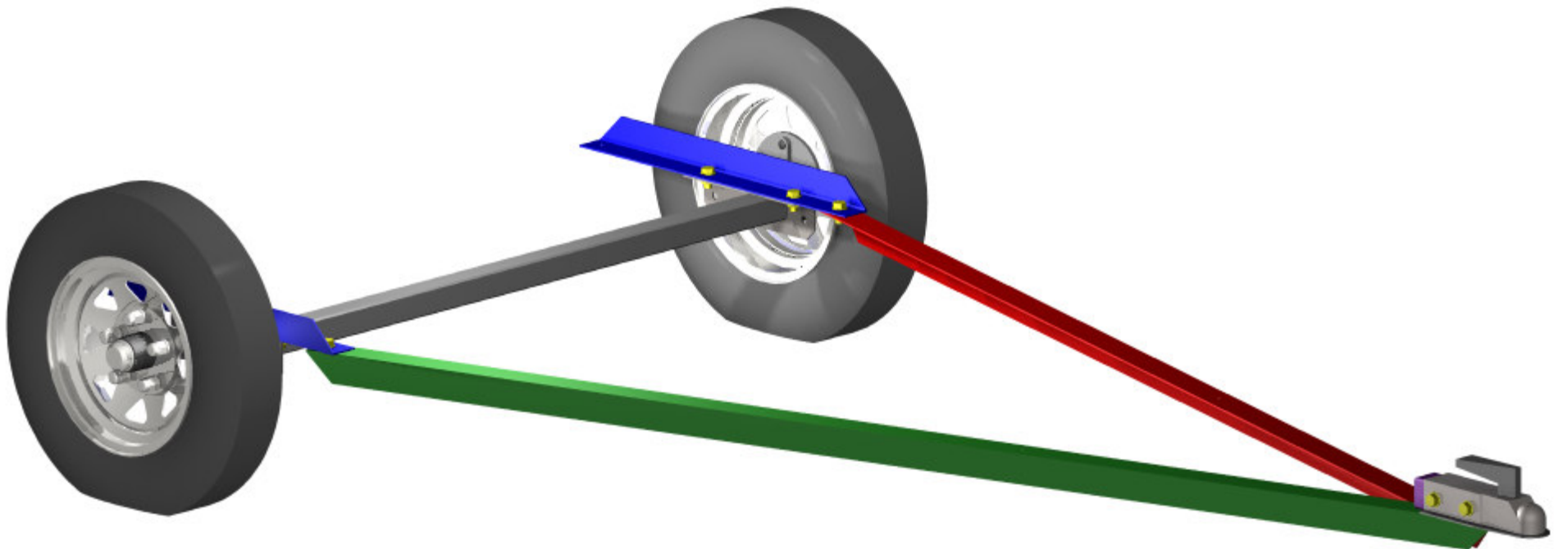

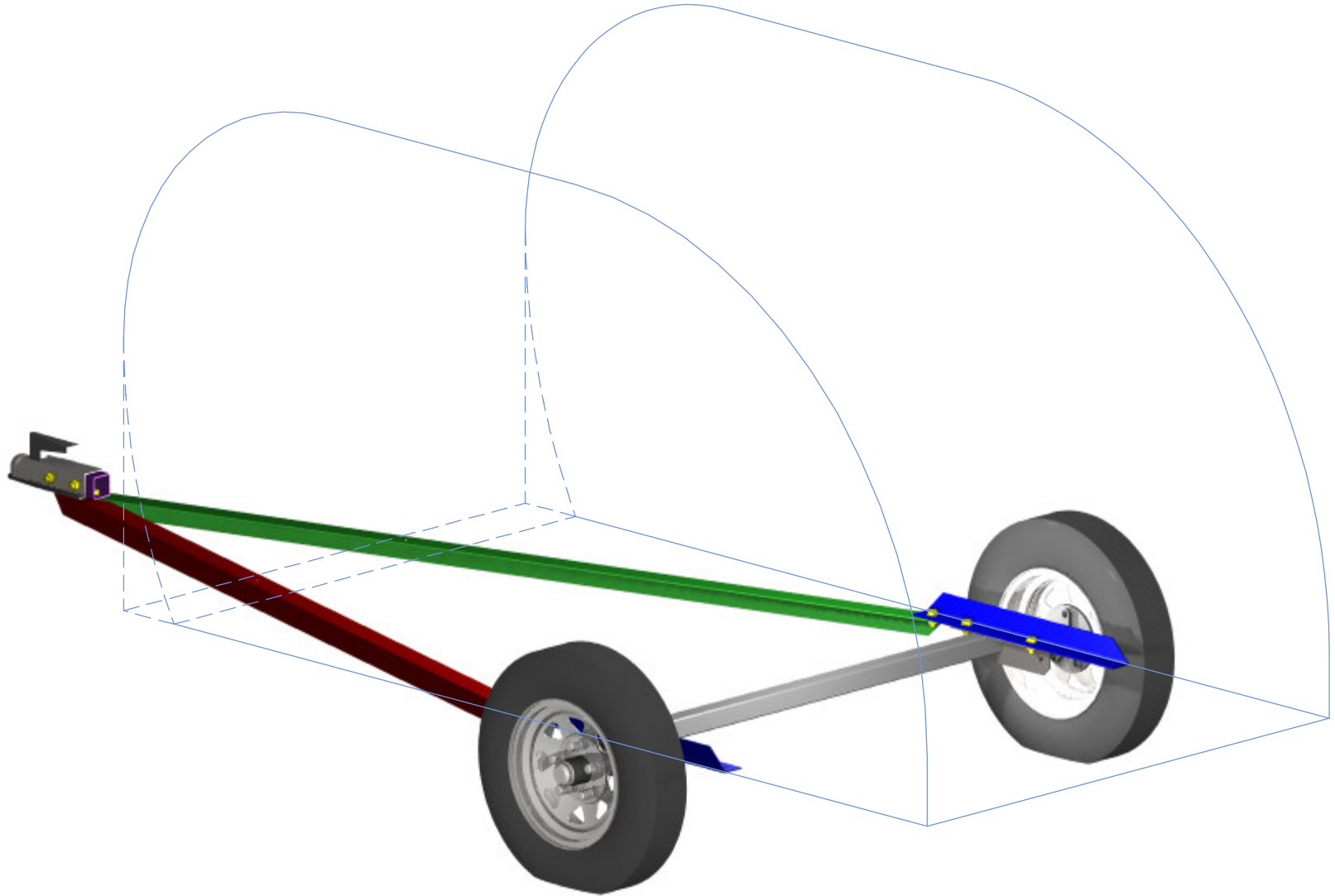

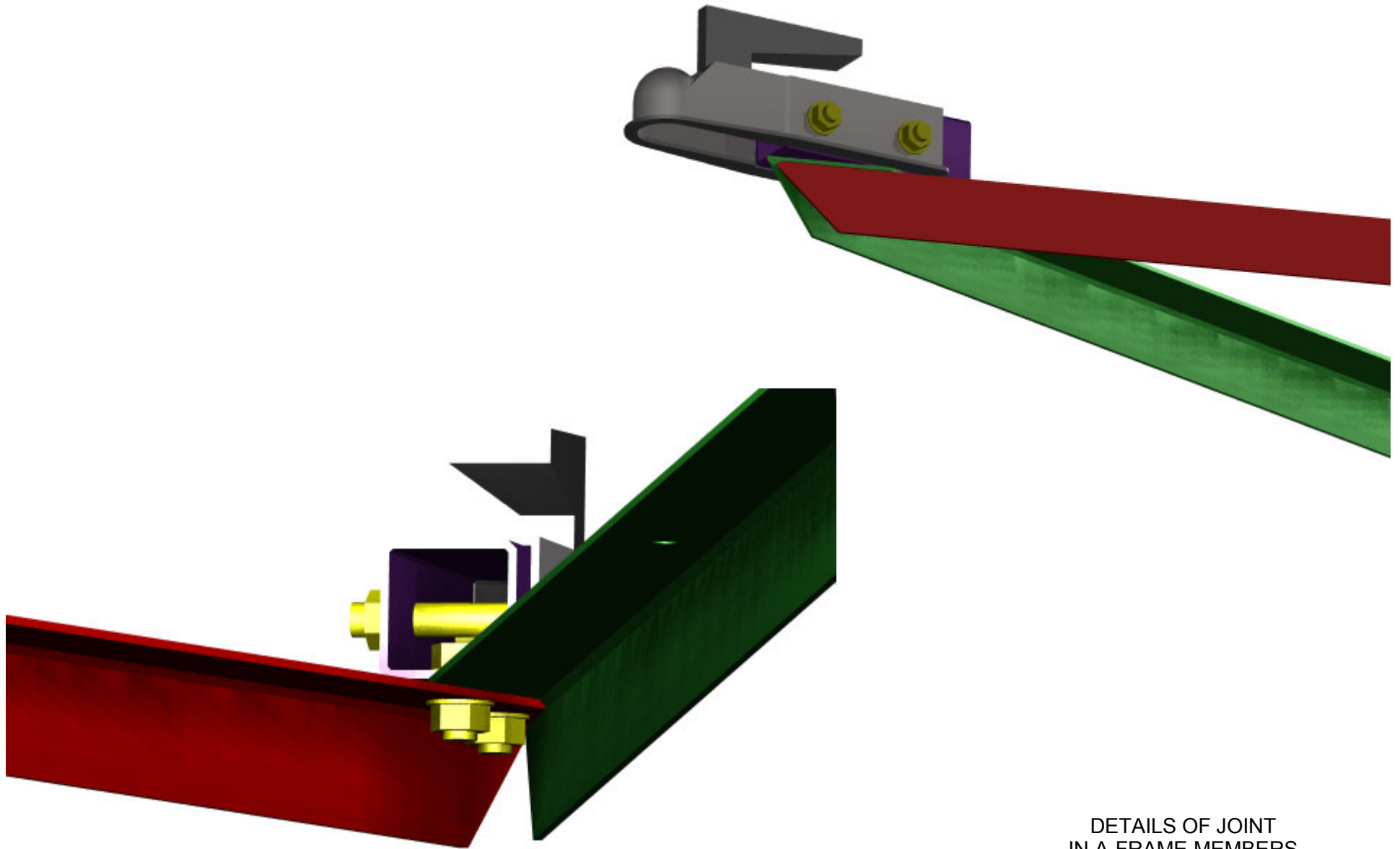

DETAILS OF JOINT
IN A-FRAME MEMBERS
UNDER COUPLER

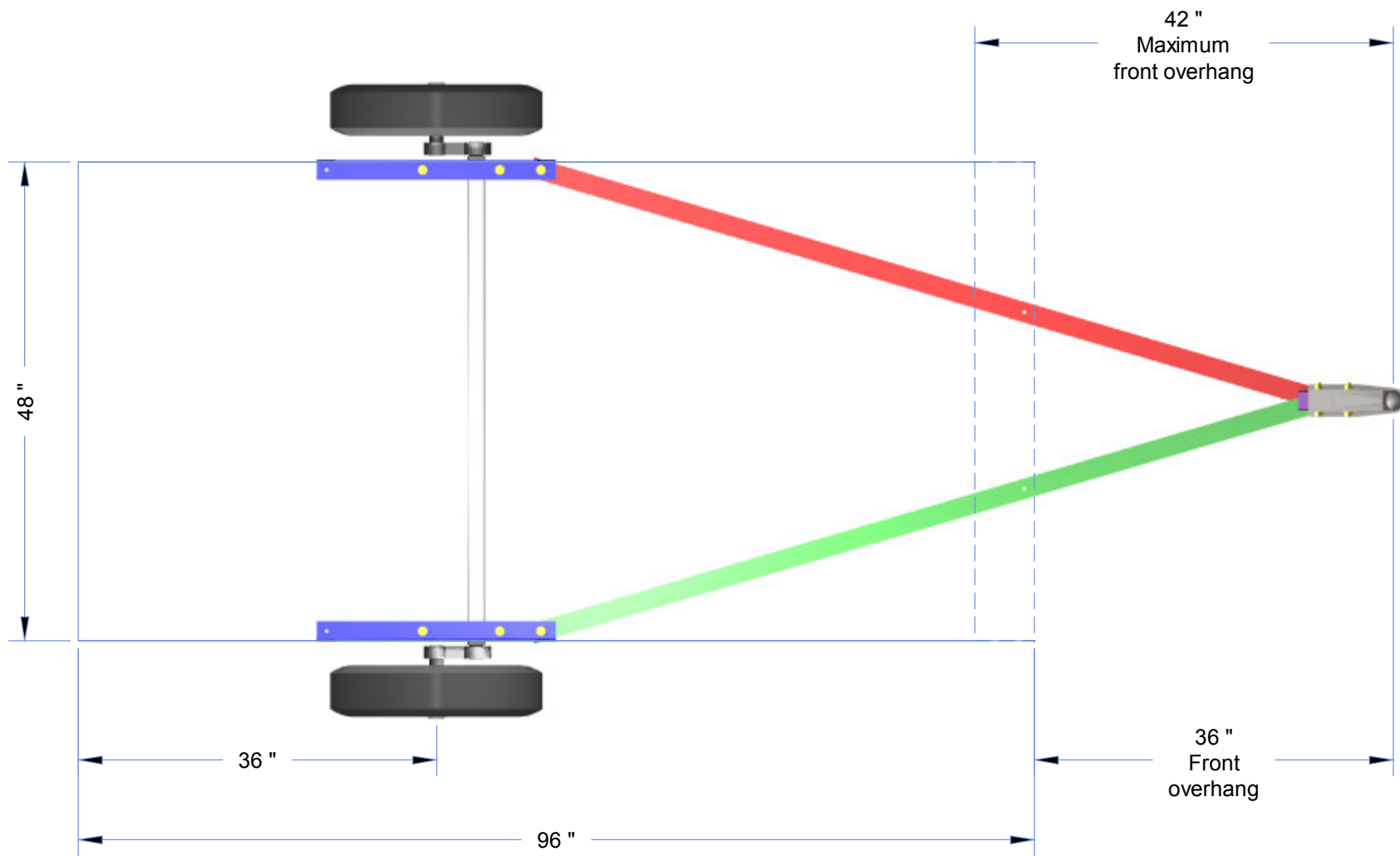

PLAN VIEW 1:16

Tyre Size	Axle start angle	Approx Deck Height H
4.80-12 or ST145R12	10 deg down	11"
4.80-12 or ST145R12	22.5 deg down	12"
ST175/80R13	10 deg down	12 3/4"
ST175/80R13	22.5 deg down	13 3/4"

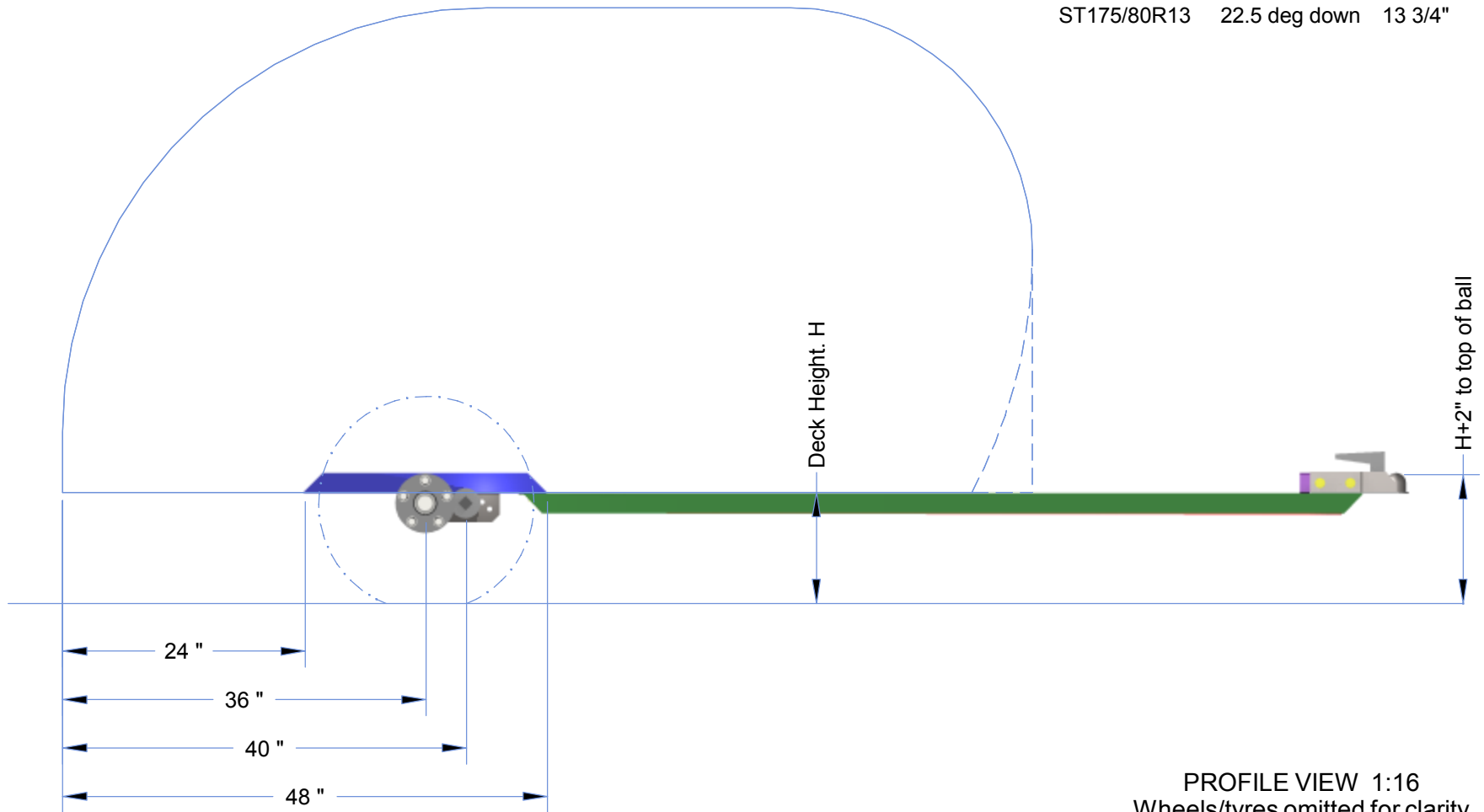

PROFILE VIEW 1:16
Wheels/tyres omitted for clarity

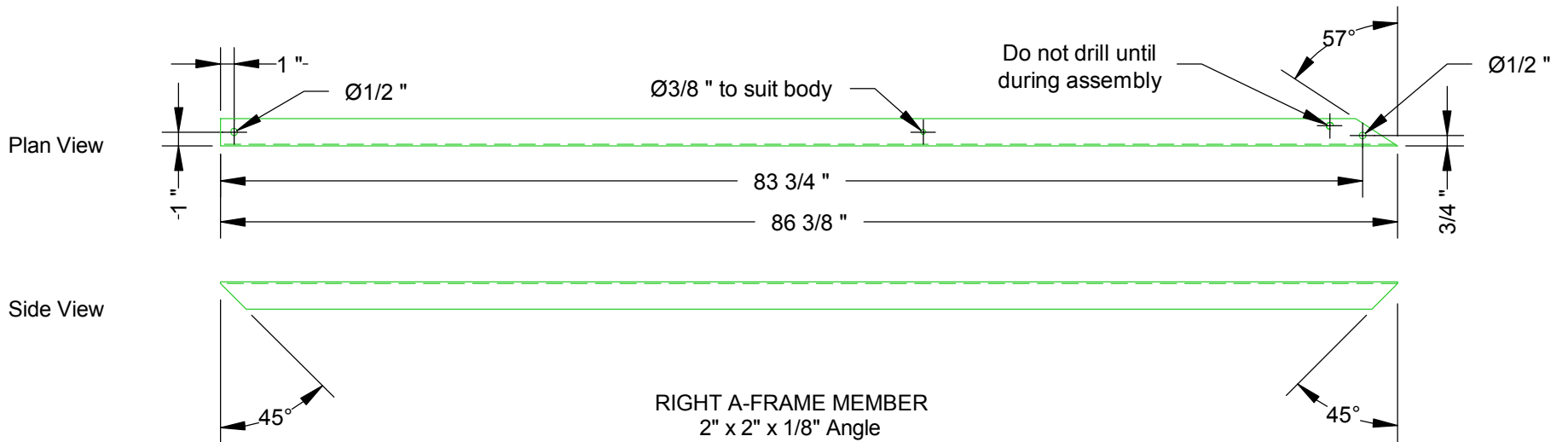
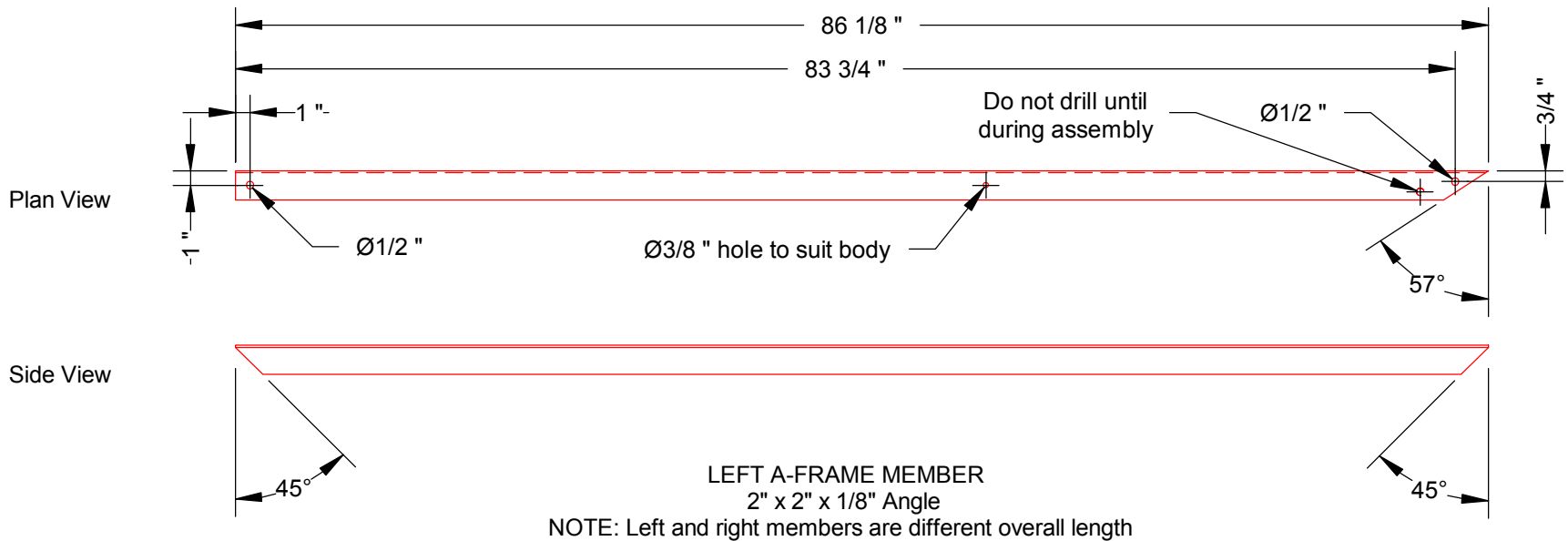

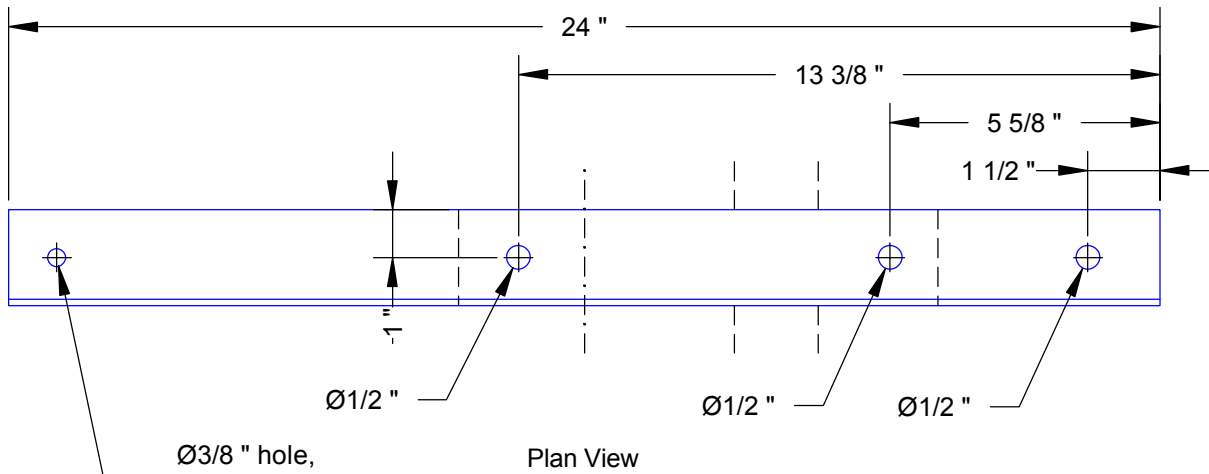

Ø3/8" hole,
2 or 3 places,
for bolts to body

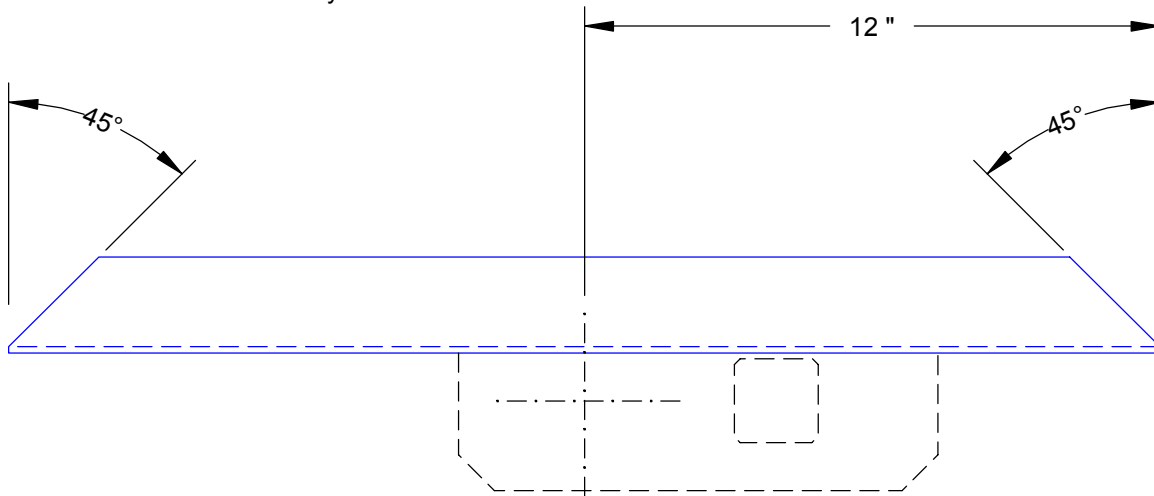

AXLE MOUNTS
2" x 2" x 1/8" Angle
Make 2 - Symmetrical

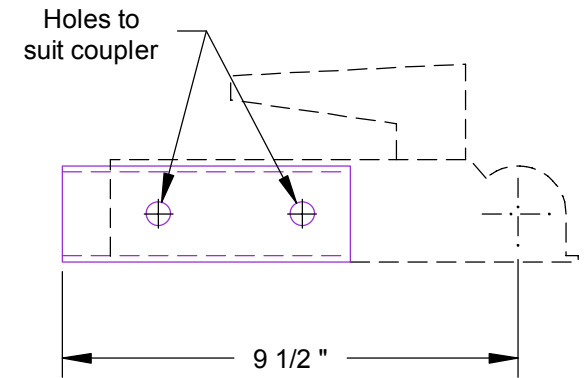
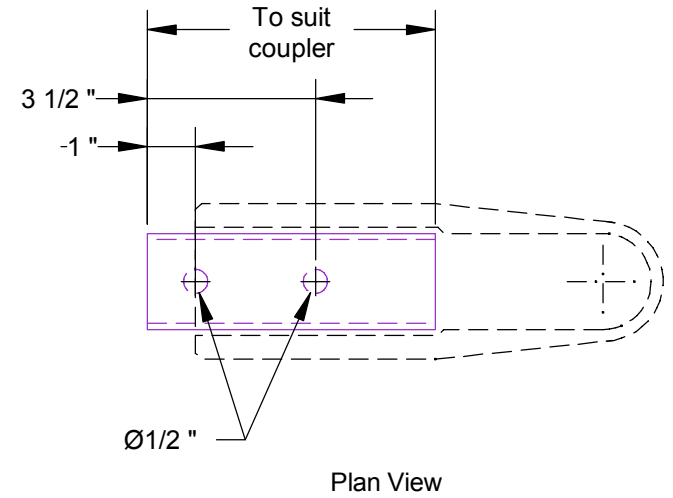

COUPLER MOUNT
2" x 2" x 1/8" Square Tube
2 off 1/2" holes in bottom side only