

TO-71

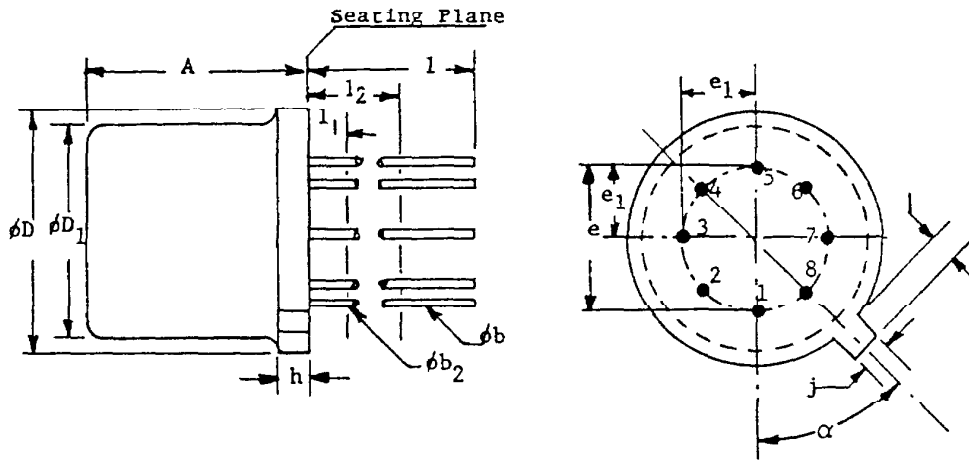

SYMBOL	INCHES		MILLIMETERS		NOTES
	MIN.	MAX.	MIN.	MAX.	
A	.170	.210	4.32	5.33	
ϕb	.016	.021	.406	.533	2
ϕb_2	.016	.019	.406	.483	2
ϕD	.209	.230	5.31	5.84	
ϕD_1	.175	.195	4.45	4.95	
e	.100 T.P.		2.54 T.P.		4
e_1	.050 T.P.		1.27 T.P.		4
h		.030		.762	
j	.036	.046	.914	1.17	
k	.028	.048	.711	1.22	3
l	.500		12.70		2
l_1		.050		1.27	2
l_2	.250		6.35		2
α	45° T.P.		45° T.P.		4, 6

4.6.33

NOTES:

1. (EIGHT LEADS). MAXIMUM NUMBER OF LEADS OMITTED IN THIS OUTLINE, "THREE" (3). THE NUMBER AND POSITION OF LEADS ACTUALLY PRESENT ARE INDICATED IN THE PRODUCT REGISTRATION. OUTLINE DESIGNATION DETERMINED BY THE LOCATION AND MINIMUM ANGULAR SPACING OF ANY TWO ADJACENT LEADS.
2. (ALL LEADS) ϕb_2 APPLIES BETWEEN l_1 AND l_2 . ϕb APPLIES BETWEEN l_2 AND .500" (12.70 MM) FROM SEATING PLANE. DIAMETER IS UNCONTROLLED IN l_1 AND BEYOND .500" (12.70 MM) FROM SEATING PLANE.
3. MEASURED FROM MAXIMUM DIAMETER OF THE PRODUCT.
4. LEADS HAVING MAXIMUM DIAMETER .019" (.483 MM) MEASURED IN GAGING PLANE .054" (1.37 MM) + .001" (.025 MM) - .000" (.000 MM) BELOW THE SEATING PLANE OF THE PRODUCT SHALL BE WITHIN .007" (.178 MM) OF THEIR TRUE POSITION RELATIVE TO A MAXIMUM WIDTH TAB.
5. THE PRODUCT MAY BE MEASURED BY DIRECT METHODS OR BY GAGE.
6. TAB CENTERLINE.