

# THE TIME OF THE NAGUALS

Interzone anthology

Tome 2

Research

Interzone Editions

# Contents

## Dreamachine:

- Here to Go : Planet R 101 Brion Gysin - Terry Wilson .....	4
- Dreamachine (Extract of Re/Search : William Burroughs/Throbbing Gristle/Brion Gysin) 1982 .....	9
- Isabelle Aubert-Baudron : HOW TO BUILD A SIMPLE AND CHEAP DREAMACHINE ..	10
- Isabelle Aubert-Baudron : Photos of dreamachines .....	16
- Simon OWEN: Electronic dreamachine .....	17
- Kevin MEREDITH: Build your own pocket dreamachine! .....	18
- Coolcat : dreamachine plan with a fan .....	19
- Noah: Dreamachine plan of Brion Gysin .....	22
- 10111: Dreamachine manufacture .....	25

## Detoxification:

Roger Holden: Alternative, Affordable Treatment for Feline Leukemia : The "Burroughs' White Cat" Challenges the Board .....	28
Mails exchanges : Roger Holden-Isabelle Aubert-Baudron .....	30
Apomorphine cure:	
- Ian Sommerville : Protocole of the apomorphine cure .....	31
- Letter from William Burroughs and James Grauerholz (1983) .....	33
- The "sober-you-up" drug (review Doctor) .....	35
- Isabelle Aubert-Baudron : Letter to Dr Martensen-Larsen .....	38
- Answer from Dr Martensen-Larsen .....	39
- Jim Byer : Opiates intoxication : Some suggestions from the doc .....	40
- Dr Dolophine : Report From Tasmania August 1998 .....	41
- Mail exchanges : Dr Dolophine – Isabelle Aubert-Baudron .....	42

## Dreams:

Isabelle Aubert-Baudron : <a href="#">A simple method to get rid of nightmares</a> .....	44
Dreams (Interzone) .....	46

## Economy : a non-Aristotelian economy

Money ? .....	67
I New data on money : what are we talking about exactly? .....	76
II Application of those data in the context of the Zone .....	82

III Proposition to experiment a zone of free exchange .....	87
IV A non-Aristotelian economy (january 2002) .....	91
V. January 2004 : <u>The Academy 23</u> .....	95
VI. January 2006 : A non-Aristotelian globalization ? .....	99
VII. January 2009: Interzone Editions: experiment of a non-Aristotelian economy .....	102

Non ordinary levels of reality:

J'lahn :

- The Root .....

105

- The 111 experience .....

109

Nicholas Knutsen : Synchronicity .....

122

Francis C Biley : An experiment in accessing pandimensionality: The literary poetics and deconstruction techniques of William S Burroughs applied to the Science of Unitary Human Beings .....

126

Jakearoo42 : the Quantum experiment .....

136

Amy Bolot: The Quantum Generator .....

138

Juanjo Patanegra : THE QUANTUM SHE-CAT (I) .....

141

Daniel Gualda : Planos para una maquina de conferencia triple .....

145

Joshua Dan : Space Travel .....

147

Allan Cronin :

- THE EXTRACORPOREAL EFFECTS OF BIOACTIVE SUBSTANCES .....

148

- Pain, Death and LSD: *A Retrospective of the Work of Dr. Eric Kast* .....

150

Terata: Nova Terata : Stripping Away the Flesh .....

154

Rick Gentry: Who are you right now .....

159

D.Mayers: A Mythology for the Third Millennium .....

160

Illustrations:

Isabelle Aubert-Baudron: First dreamachine (1981), Victor Bockris (1990), dreamachines .....

16

Simon Owen: Electronic dreamachine .....

17

Kevin Meredith: Pocket sized dreamachine .....

18

Dreamachine plan of Brion Gysin .....

22

Daniel Gualda: Animation: "First Dreamachine" .....

24

1101.org: Dreamachine manufacture .....

25, 26

Cover of "The Man of Light in Iranian Sufism" by Henri Corbin .....

27



# Dreamachine

## Here to Go : Planet R 101

Brion Gysin - Terry Wilson

Listen to Brion in this program of France Culture : [Gysin.ra](http://Gysin.ra)

### If you want to change fate ...cut up words :

We began to find out a whole lot of things about the real nature of words and writing... *What are words and what are they doing ? Where are they going ?* The cut-up method treats words as the painter treats his paint, raw material with rules and reasons of its own... Abstract painters found that the real hero of the picture is the paint. Painters and writers of the kind I respect want to be heroes, challenging fate in their lives and in their art. *What is fate ?* Fate is written : *Mektoub* means "It is written." So ... if you want to challenge and change fate ... cut up words. Make them a new world. (BG to Robert Palmer, *Rolling Stone*, May 1972). (p. 55)

### Magical origins of art

(p.181)

Burroughs was always very good at disappearing. He could slide into even the most inoffensive wallpaper, such as the rose wallpaper he was always writing about. The great artist learns to disappear into his work. This is a very hard thing to do, hard in every sense of the word. It is a very painful decision to take because you are going to miss out on all those tasty goodies which go so easily to lesser artists who won't have to give up anything in order to succeed. A mere trick of the light. You must always remember that art itself is the Great Illusion, the illusion which Madame Maya manufactures in order to hold the rest of the house of mirrors together.

So ... we did a great deal of lengthy mirror-gazing at that time. We felt that we had all the time in the world to give such explorations and we did see some strange stuff, just like "they" always said we would. *We* knew we were on the right track when our tricks worked, you see, and they did. For example, the cut-ups, they worked immediately and they still do although we know a great deal more about them than we did when every new cut of the scissors gave out something hilarious and to the point. The permutations discovered me - because permutations of course have been around for a long time; in the whole magic world permutations are part of the Cabalistic secret - and they worked as soon as the BBC asked me over in London and gave me their Special Effect & Footsteps studio and the staff to work with - first crack of the bat and we made *I AM THAT I AM*, and acknowledged sound poetry classic. The Dreamachine worked from the first time it spun around a light bulb and we closed our eyes in front of it. Etcetera.

Of course the Establishment never wanted to pay us any money for any of these things. That is a whole other branch of the art, I guess. Never mastered it. Not yet, anyway.

**>It is to remember that all art is magical in origin - music sculpture writing painting - and by magical I mean intended to produce very definite results. Paintings were originally formulae to make what is painted happen. Art is not an end in itself, any more that Einstein's matter-into-energy formulae is an end by itself. Like all formulae, art was originally *functional*, intended to make things happen, the way an atom bomb happens from Einstein's formula. Take a porcelain stove and disconnect it and put it in your living room with ivy growing over**

it... it may be a good-looking corpse but it isn't *functional* anymore. Or take a voodoo doll full of pins - authentic West African, \$500 on the 57<sup>th</sup> Street - and hang it on the wall of your duplex loft. It isn't killing enemies anymore, and the same goes for a \$5,000 shrunk-down head, which a fashionable shrink bought for his consultation room. Writing and painting were one in cave paintings, which were formulae to ensure good hunting...

The painting of Brion Gysin deals directly with the magical roots of art ... the picture constantly change because you are drawing into time travel on a network of associations. Brion Gysin paints from the viewpoint of timeless space. (WSB, Essay on BG in *Contemporary Artists*).

Terry : The timelessness of your painting - past present and future merge on the page, and the painted page, as you call it ... Did you specifically give William a way out of time ?

Brion : How could I ? I had my way; William had his own. My way was and is to look at a problem as a whole and then proceed to eliminate, to pare away one legitimate element after the other until I find myself left with the simplest answer which remains. William on the other hand , if pushed to it - and he could be pushed to it only by the most exact formulation of the question - used to submit it to what I always thought of as "William's Machine." As I said before, if I formulated a question such as *What is Time?* I would propose it to William who would stand there looking rather strange, as if he were swallowing his Adam's apple. It would move up and down for quite a few minutes, and, um, he seemed to be making this sort of humming, like he has a machine in there that he set to work ... as though he had submitted this question to a computer (chuckling) and he would come up with a convincing answer, like : *Time is that which ends* It was like having one's oracle at home at all hours. So, in that way, a good many amusing and instructive things were ... discovered or rediscovered or... made more evident to us by various applications of those two, uh, procedures. Presumably, that machine humming away inside and the answer that came back could be said to have been of the Third Mind.

### **Cut-ups discovery**

T Yes. But why did you need someone to give the technique to, rather than use it yourself?...

B It's a very good question. You mean the cut-ups, of course. When I first fell into the cut-ups and put those texts together which appeared in *Minutes to Go*, they amused me. I laughed out loud. I knew all about Breton's precious and pseudoautomatic writing and I had heard of the poem that Tristan Tzara pulled out of a hat about the same time that Aragon was reciting his alphabet poem to the avantgarde of the 1920s. all that was old hat. The cut-ups were brand new because the words were treated like mere material, like the images they are and treated in a painter's creative way rather than a writer's metaphysical view of language as the lesser part of speech. Words were attacked physically with the scissors or framer's Stanley blade. Words spurted into action as in my text "Cut-Ups Self -Explained," immediately proved...

I showed the first texts to Burroughs hoping to hear him laugh out loud as I had. He took off his glasses to reread them even more intently, saying : " You've got something big here, Brion." He'd put his glasses back on to stare at me across the room, as I explained to him how the texts had been made, then he'd snatch them off again to plunge right back *into* the pages. He recognized immediately that this was a tool of enormous importance to him and he said rather, diffidently: "Do you mind if I try some of this stuff ?" and I said, "No, go ahead, that's what it's *for*." And he did, he did it to his own stuff, he had a suitcase full of it, the mighty manuscript that was not in *Naked Lunch* but was about to become, uh... *Dead Finger Talk*, *Soft Machine* and *Ticket That Exploded*. William worked like a fiend and then went off to the Edimburgh Writer's conference where he read a paper on "The Cut-up Method of Brion Gysin." He didn' t come along and say, Look, here's some hot new stuff of mine, my cup of genius is brimming over. No, he took the literary bull by the horns

and said what I said : "*Writing is 50 years behind painting. I propose to apply the painter's techniques to writing... etc.*"

p. 272 :

Both extraordinary encounters and unusual experiences had led me to think about the world and my activity in it in a way that came to be termed psychedelic... I have spent more than a third of my life in Morocco where magic is or was a matter of daily occurrence, ranging from simple poisoning to mystical experience. I have tasted a pinch of both along with the other fruits of life and that changes one's outlook, at least somewhat. Anyone who manages to step out from his own culture into another one can stand there looking back at his own under another light ... Magic calls itself the Other Method ... practiced more assiduously than hygiene in Morocco, though ecstatic dancing to music of the secret brotherhoods is, there, a form of psychic hygiene. You know your music when you hear it one day. You fall into line and dance until you pay the piper... Inevitably something of all this is evident in what I do in the arts I practice.

## **Control**

(p. 218)

**...in Fulham Road Willy Deiches and Brenda Dunks, two would-be one-were computer operators with IBM who now function of their own (,) have perfected a scrapbook system from newspaper cuttings for predictions and assessments along the lines of Wm's scrapbooks, but with a built-in 24-hour mathematics of their coordinate points for greater accuracy. They also claimed to be in touch with Control in Venus through IBM Seattle. Questions may be put to Control at 12 shillings a time (it used to be free) and the answers are interesting. Wm has sent in a whole lot and we are waiting for these answers ... (Anthony Balch to BG, November 4 1968)...**

**Q: What is word ?**

**A: Word is ETC.**

**W: What does ETC mean ?**

**A: Electrical time control.**

**Q: what is virus ?**

**A: Virus is B.**

**Q: what is the relation between word and virus ?**

**A: Power....**

p. 228 :

**Q: When you state that virus is B, are you referring to my virus ? To B-23 ?**

**A: Yes.**

**Q: Can B-23 give you orders now ?**

**A: Yes.**

**Q: Are you controlled by the need to control ?**

**A: Yes.**

**Q: Are you in point of fact addicted to certain brain stimulations ?**

**A: No, but this is used on control subjects.**

**Q: Are the erotic convulsions of cyanide poisoning experienced as pleasurable or otherwise ?**

**A: Otherwise.**

**Q: What is the most horrific image in the Book. Is it a bombing incident ?**

**A: Yes.**

**Q: Was it to obtain such an incident that the bomb was dropped on Hiroshima ?**

**A : Yes.**

**Q: Who really gave the order ?**

**A: Control.**

**Q: When and why did Control come here ?**

**A: You have been told when, and the reason you cannot know.**

T Control at one time said it received orders from Virus B and was controlled by the *need* to control, and at another time it claimed to be God - "no one controls Control" - very contradictory answers -

B "No one controls Control?" A tautology , surely... no ? "Control is Control" would be a tautology, and that's essentially what it's saying...

T Why is this planet so desirable to alien agencies ?

B Because , one gets a *body* on this planet, and it is better to have a body than not to have a body, and to our almost certain knowledge there are no bodies, there may be other *intelligences*, but there are no other bodies in our galaxy.

T Anthony asked Control: "Is there immortality?" and the answer was: " Not for humans."

B No, the earth is for humans. And it's a good place to be, till you fuck it up *completely*, as we're doing.

T Are you *controlled* by Control ?

B Yes, I think I *am* controlled by Control, I am controlled by my *body*. As in childhood, certainly, one grows up thinking one *is* one's body and only later perhaps finds that one is not... But one is still controlled by the *apparatus* in which one exists, whether it be the circulation of the blood, or the circulation of the lymph of which we are even *less* aware - we're not ordinarily aware of our blood except at certain moments of excitement, but we're really *never* aware of our absolute necessary elimination of dead cells, waste which is being carried on and oxidized by the movement of the lymph in our bodies. In both cases we need oxygen. So we are controlled by our need of oxygen, if it were only to that extent.

Many ears ago I said: "I can show you only what you have already seen," and it means to me now that everything can be *seen*, and I mean really visualized with the eyed closed, would seem to be contained within the visions that one experiences with the Dreamachine. Therefore one might come to the conclusion, perhaps hasty, that everything that can be seen can be seen only in the alpha band, between eight and 13 flickers, light interruptions, per second. If this is so then we are programmed. If indeed there is such a thing as the alpha band, which is now perceptible - has been for the last 30 years since the invention of the electroencephalogram - we may presume that this is a programme...

The figures involved, of the possibilities of combينات, of permutations, and powers in the Human Programme, is very well explained by some of the more popular writers in modern science like... Carl Sagan, that book...

T *Dragons of Eden*.

B yeah. *The Dragons of Eden*; you find a few dazzlingly clear pages in there showing you the almost in - all *but* incalculable, but nevertheless *calculable* possibilities within the brain. So that the brain itself is laid down with certain limit beyond which it cannot go, therefore it would seem to be programmed. And if there is a programme there must be a programmer... and the programmer would seem to be Control.

Conclusion:

The sands of Present Time are running out from under our feet. And why not ? The Great Conundrum: "What are we here for?" Is all that ever held us here in the first place. Fear. The answer to the riddle of the Ages has actually been out on the street since the First Step in Space. Who runs may read but few run fast enough. What are we here for ? Does the great metaphysical nut revolve around that ? Well, I'll crack it for you, right now. What are we here for ? We are here to go."

**Brion Gysin**

---



# Dreamachine

(Extract of Re/Search : William Burroughs/Throbbing Gristle/Brion Gysin)1982

R/S: *What's happening with the Dreamachine? At one point.. . you said it could have been the drugless turn-on of the 60s. Why didn't it happen?*

BRION: One of the reasons is that ... I think it *scares* people... Because of the fact that it deals with that area of *interior* vision which has never been tapped before. Except in history, one knows of cases — in French history, Catherine de Medicis for example, had Nostradamus sitting up on the top of a tower (which is now just being restored, at the present time, over there). And there was no pollution in those days . . . one didn't have any screen between the man on top of the tower and the sun. And he used to sit up there and with the fingers of his hands spread like this would flicker his fingers over his closed eyes, and would interpret his visions in a way which were of influence to her in regard to her political powers . . . they were like instructions from a higher power.

R/S: But they were good visions ?

BRION: They could also foretell bad things too. Peter the Great also had somebody who sat on the top of a tower and flickered his fingers like that across his closed eyelids . . . And any of us today can go and look out the window or lie on a field and do it, and you get a great deal of the *type* of visions — in fact, it's the same area in the alpha bands of excitation of the brain — within the alpha band between eight and thirteen flickers a second. And the Dreamachine produces this continuously, without interruption, unless you yourself interrupt it by opening your eyes like that.

So, the experience can be pushed a great deal further — into an area which is like real dreams. For example, very often people compare it to films. Well, who can say who is projecting these films — where do these films come from? If you look at it as I am rather inclined to now — like being the *source of all vision* — inasmuch as within my experience of many hundreds of hours of looking at the Dreamachine, I have seen in it practically everything that I have ever seen — that is, *all imagery*. All the images of established religions, for example, appear — crosses appear, to begin with; eyes of Isis float by, and many of the other symbols like that appear as if they were the Jungian symbols that he considered were common to all mankind.

And then one goes very much further — one gets flashes of memory, one gets these little films that are apparently being projected into one's head . . . one then gets into an area where all vision is as in a complete circle of 360 degrees, and one is plunged into a dream situation that's occurring all around one. And it may be true that this is *all* that one can see . . . that indeed the alpha rhythm contains the whole human program of vision. Well — that is a big package to deal with — and I don't think anybody particularly wants. . . *amateurs* sitting in front of Dreamachines fiddling with it, perhaps...

---

# HOW TO BUILD A SIMPLE AND CHEAP DREAMACHINE

by [Isabelle Aubert-Baudron](#) (1981)

Discoverers : BRION GYSIN and IAN SOMMERVILLE

*The plan below is for a 78 rmp dreamachine. See below the drawings of the plan for the explanations for a 45 rpm dreamachine.*

*It's different from Brion's plan as this dreamachine allows to get to different rhythms inside the alpha band (7 to 13 flashes per second)*

## EQUIPMENT

- 1 record player working at the speed of 78 tours/minute,
- 1 big cardboard sheet, rigid enough for the future cylinder to stand up, and soft enough to be easily cut and worked; you can get sheets of different thickness and dimensions in an office stationery. Choose the darkest color you can find as the cardboard must be opaque to the light of a 100 watts bulb.
- 1 graduate rule of 30 or 40 cm long,
- 1 set square,
- 1 thin lead pencil,
- 1 rubber,
- cardboard glue,
- 1 cutter,
- 1 100 watts bulb,
- 1 lamp socket,
- 1 male plug,
- electric lead (5 to 6 meters long),
- 1 multiplug,
- 1 tape measure to measure the circumference of the turn table of the record-player,
- clothes pegs.

## PRINCIPLE OF THE DREAMACHINE

To build a dreamachine, you need a cylinder with holes in it, fixed upon the turntable of a record player turning at the speed of 78 tours/minute.

In the middle of the machine, one 100 watts bulb. When you seat in front of the machine, the light of the bulb must come in front of your closed eyes intermittently, according to a rhythm from 7 to 13 light-flashes per second, which is the rhythm of alpha waves of the brain.

For the effects, refer to "Colloque de Tanger", vol. 1, Christian Bourgois éditeur, or "Here to Go - Planer R 101", Brion Gysin - Terry Wilson.

## BASIC CALCULUS

- The rhythm of the light flashes is from 7 to 13 flashes/second.
- The turntable of the record-player turns at the speed of 78 tours/minute = 78 tours/60 seconds.
- In one second, the turntable makes :  $78/60 = 1,3$  tour.
- 1 flash corresponds to a hole in the cylinder.
- 1 row of 6 holes (6 flashes) will give for every tour a rhythm of  $6 \times 1,3 = 7,8$  flashes/second
- 1 row of 7 holes :  $7 \times 1,3 = 9,1$  fl/s
- 1 " " 8 " :  $8 \times 1,3 = 10,4$  fl/s
- 1 " " 9 " :  $9 \times 1,3 = 11,7$  fl/s
- 1 " " 10 " :  $10 \times 1,3 = 13$  fl/s

The length of the cardboard sheet must be equal to the circumference of the turntable. The dimensions of the plan are the ones of a Dual 1010 record player; the circumference of its turntable is 85,5 cm.

## PROCEDURE

1. Measure the circumference of the turntable with the tape measure.
  2. Transfer this dimension on the length of the cardboard sheet from the left side at the top and at the bottom of the sheet. Draw a line joining the 2 points, parallel to the width of the sheet.
  3. Once the line is drawn, draw another one, parallel to the first one, 4,5 cm on the right far from it; this is to delimit a little band which, at the end of the operations, will be stuck to the left width to make the cylinder. With the cutter, cut the sheet along the second line. So the final length of the cardboard is :  $85,5 \text{ cm} + 4,5 \text{ cm} = 90 \text{ cm}$ .
  4. At the top of the cardboard, on the right and left widths, measure 2,5 cm. Draw a line joining the 2 points. You get a band of  $85,5 \text{ cm} \times 2,5 \text{ cm}$ . Do the same at the bottom of the cardboard in drawing a band of 3 cm wide (see the drawing). The width between the 2 bands is  $65,5 - (2,5+3) = 60 \text{ cm}$ .
  5. Now divide this width of 60 cm in 5 equal parts of 12 cm. Measure 5 times 12 cm on the right and left widths. Draw the lines joining those new points. You get 4 new lines, parallel to the length.
  6. Now calculate the dimensions of the holes in every row. The upper row will contain the most numerous holes (10) and the row of the bottom, the less numerous holes (6), so the base of the cylinder is as solid as possible (see the plan of the cardboard of the cylinder).
- a) Upper row :
- \* Divide this row in 10 equal parts :  $85,5/10 = 8,55 \text{ cm}$
  - \* Measure 10 times this dimension at the top and at the bottom of the upper row, in beginning by the left.
  - \* Draw the lines joining the new points : you get 9 parallel lines 8,55 cm far from one another (these lines will be in the middle of the holes) delimiting 10 rectangles of  $12 \times 8,55 \text{ cm}$ .
  - \* Take the plan of every hole : the line IJ represents the new lines you have just drawn. On this line IJ, measure 2 times 1,5 cm, from I and from J, so you get the points K and L. From these points, perpendicularly to IJ, measure the points A, B, C and D, 2 cm far from K and L. Draw the lines joining A and B, B and D, D and C, C and A. The rectangle you get is the hole.

\* Proceed the same way to get all the holes of the row. On the left width of this row, you only get half a hole. On the right side, at the end of the row, the last hole encroaches upon the band to stick; the second half of this hole will fit to the half hole on the left when you stick the cylinder, and this for every row. In other words, the left half hole and the hole at the right end of the row will make the same hole.

b) Second row :

It will contain 9 holes. Proceed as you did for the upper row, but divide the length of the cardboard by 9 :  $85,5 / 9 = 9,44$  cm. Proceed as before with this new dimension and so for the other rows :

c) Third row :

8 holes :  $85,5 / 8 = 10,62$  cm

d) Forth row :

7 holes :  $85,5 / 7 = 12,14$  cm

e) Fifth row :

6 holes :  $85,5 / 6 = 14,16$  cm

Every hole has the same dimensions, whatever the row may be.

7. Once you have delimited all the holes, cut them with the cutter. Put the cut pieces of cardboard aside, you will need them later on.

8. Put the cardboard sheet upon the turntable in giving a cylindrical shape to it. Temporarily fix the 2 widths the one on the other with clothes pegs. Make sure the base of the cylinder fits with the dimensions of the turntable and that the left half holes fit with the holes of the right width. Do not stick the edges yet.

9. If the turntable is covered with a rubber surface, delicately unstick the edges of this surface; you are going to use it to maintain the cylinder in position. If there is no rubber surface, take a thick piece of rigid cardboard and cut it according to the exact dimensions of the turntable. Make a hole in the middle, like a LP record, in introducing it in the axis of the turntable.

10. Go back to the cardboard sheet. Take the cut rectangles ABCD you had previously put aside, and solidly stick them at the bottom of the sheet on the width so you get little tongues to be fold and slipped perpendicularly under the rubber surface, to keep the cylinder upon the turntable. Put as many tongues as needed.

11. Your cylinder is ready. Stick the 2 widths one upon the other, maintaining the stuck band with the clothes pegs, in adapting them in the holes. Leave the pegs until the cardboard and the glue are dry.

If the upper row is not perfectly circular, in cases the cardboard would fold over the holes, make the cardboard more solid in sticking the remaining little triangles ABCD inside the cylinder.

12. Then you adapt the cylinder on the turntable in slipping the little tongues under the rubber surface or the cardboard disc. The body of the dreamachine is ready now. If you turn the record player on, the cylinder must turn on the turntable in remaining solidly fixed.

13. Then you take the bulb, the lamp socket, the electric lead and the male plug. Fix the whole lot together.

14. Put the dreamachine on a stool, near a power point, let the bulb hang in the middle of the cylinder without it to touch the edges. Adjust the length of the lead over the dreamachine in the most adapted way to the room where you are (you can pass the lead in a hook screwed in the

ceiling, make a bracket system, etc...). The length of the lead must be adjustable, so the bulb can be put in front of every row.

15. Plug the bulb, plug the record player, turn it on in setting it on the 78 tours speed. Sit comfortably in front of the machine and approach your face the closest you can. Close your eyes and watch : you get inside your head multicolored geometric and stereoscopic 360° images, and lights, the colors, shapes and designs of which constantly changes. You can vary the images in increasing or lessening the pressure of your eyelids and the distance between your face and the machine and in experimenting the different rows.

A record has been specially made to be listened to while watching the dreamachine, its rhythm is the same as the light flashes: "Heathen Earth", Throbbing Gristle (International Records), best in stereo with a headphone.

### PLAN OF THE CARDBOARD FOR THE CYLINDER

(The scale is approximative, because of the imprecision of the drawing program. Use the dimensions instead of reproducing the schema, which are here for indications, to allow to visualize the work to be done.)

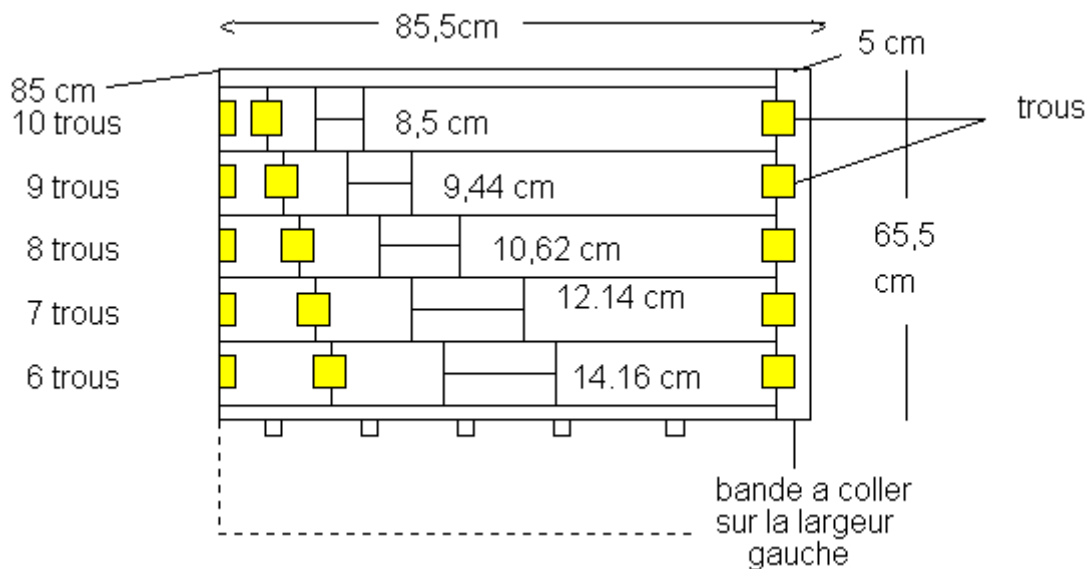

### PLAN OF EVERY HOLE

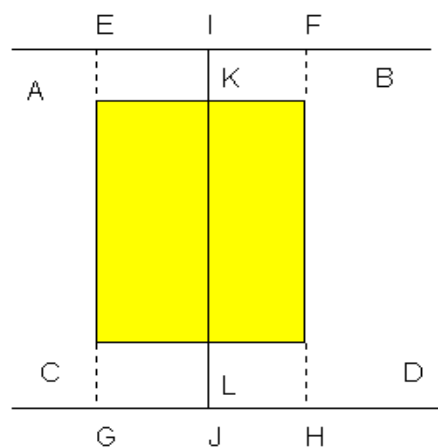

IJ = 12 cm de hauteur  
 entre chaque rangee  
 ABCD : trou rectangulaire  
 AC=BD=9 cm  
 AB = CD = 4 cm  
 IK= JL = EA = FB  
 = CG = DH = 1,5 cm

### DREAMACHINE ONCE BUILT UP

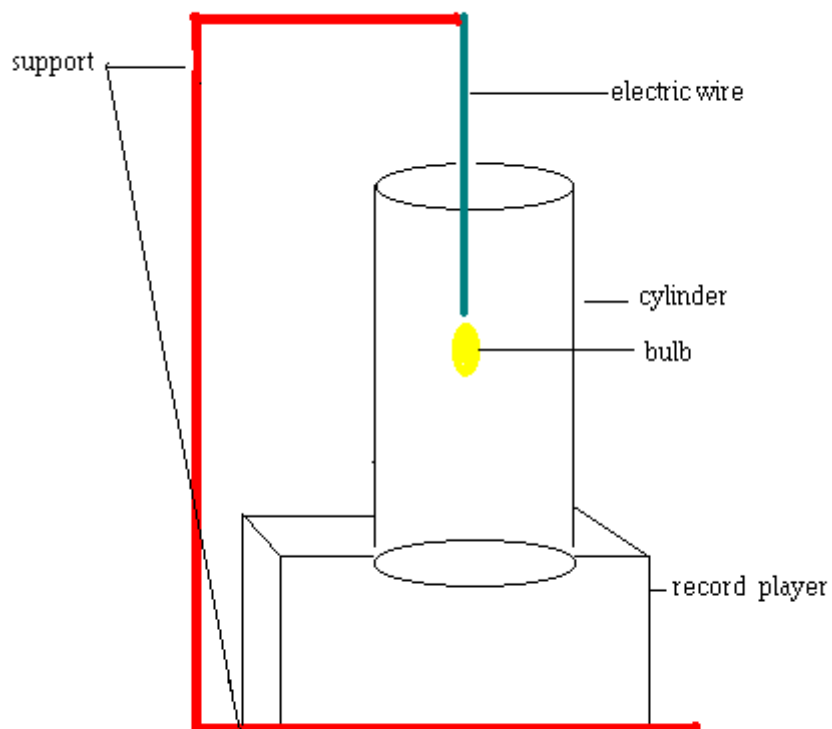
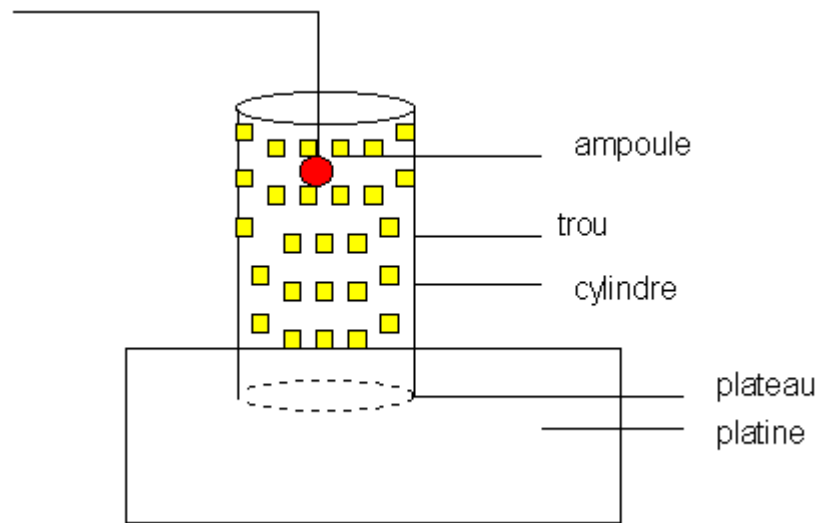

## For a 45 rpm dreamachine

Just change 78 by 45 on the plan :

- rhythm : between 7 and 13
  - turntable : 45 tours by minute = 45 tours for 60 seconds.
  - In one second, the turntable makes :  $45 / 60 = 0,75$  tour
  - one raw of 10 wholes (10 flashes) => a rhythm of  $10 \times 0,75 = 7,5$  flashes /second =
  - 1 raw of 12 holes =  $12 \times 0,75 = 9$
- etc... with 14 and 16.

Then you measure your turntable, and do just as on the plan, except you make more wholes, using the rule of three :

You probably learnt it at school when you were a kid :

if 10 kg of potatoes cost 6 \$, how much will cost 5 kg ?

You write it down on a paper : one columns for the potatoes, one for the \$ :

Potatoes	\$
10	6
5	?

Then you make a cross like a X between the two columns :

<i>Pommes de terre</i>	<i>Euros</i>
<i>10</i>	<i>6</i>
<i>5</i>	<i>?</i>

multiply the two numbers 5 by 6 and divide the result by the number with the ? :  $10 :$

$$5 \times 6 = 30$$

$$30 : 10 = 3.$$

You do the same for the dreamachine.

\_\_\_\_\_

# Dreamachines

Isabelle Aubert-Baudron



First dreamachine (1981)



Victor Bockris (1990)



2009



2009



# Electronic Dreamachine

Simon Owen : [Simon.OWEN2@lucasvarity.com](mailto:Simon.OWEN2@lucasvarity.com)

I have enclosed a circuit diagram of what I have so far, I have constructed one unit so far and hope to experiment with it this weekend. Feel free to pass it on. The circuit is an oscillator which switches the bulb on and off at frequency determined by the adjustable 5K pot.

Simon Owen

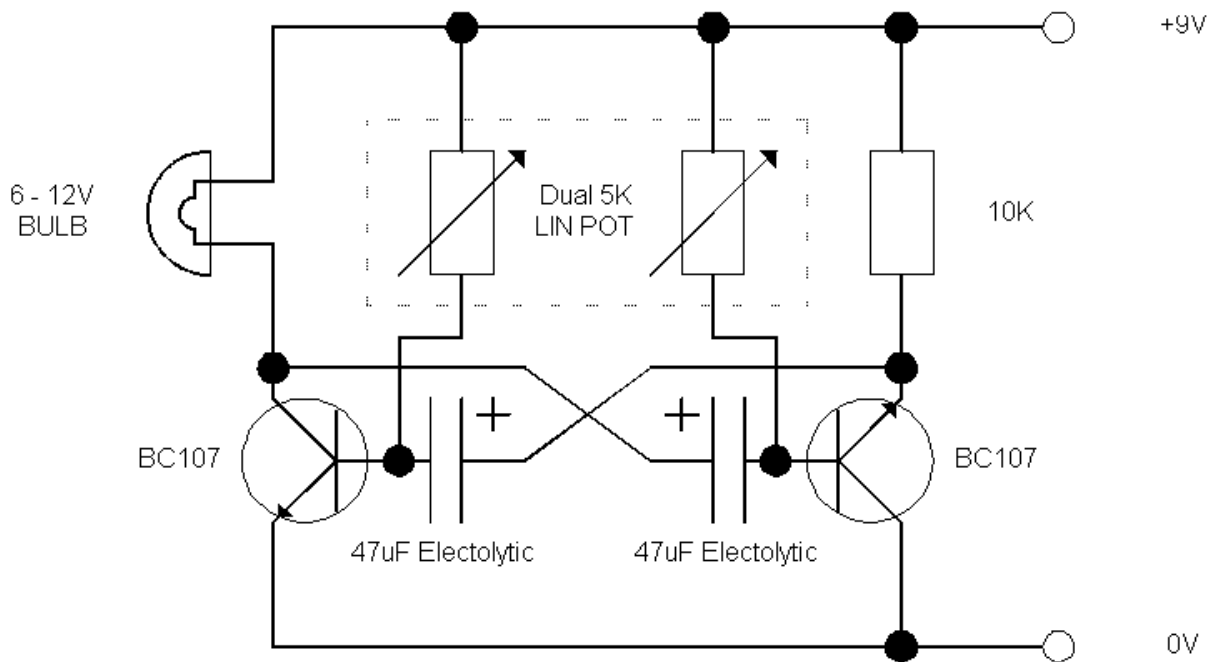

# Build your own pocket-sized Dreamachine !

By Kevin Meredith

[www.myspace.com/ermineviolin](http://www.myspace.com/ermineviolin)

Questions, suggest, improvements etc. : [Kevin S. Meredith: alan\\_one@msn.com](mailto:alan_one@msn.com)

This is a weekend project I just finished putting together (Friday, May 26, 2006). It's inspired by Brion Gysin's Dreamachine from 1959 which you can read about [HERE](#)

I have designed this simple strobing Dreamachine-type circuit that can be built into a small pocket size box. It flashes between 7Hz and 14Hz with a speed control. Attached is the schematic diagram and a picture of my finished prototype. Please feel free to distribute the schematic however you like.

I was going to build a proper Dreamachine, but I didn't have room for it and record turntables at cheap prices are hard to come by - SO I came up with this little circuit that does essentially the same thing but in a small project box that you can fit in your pocket. I call it the Electro-Hallucinator.

It's basically just a LED chaser that goes at around 10Hz or so. There's a speed control that varies the rate from around 7Hz (upper range for Theta brainwaves) to 14Hz (upper Alpha). You can use any NPNs for the transistors. I used four super-bright white LEDs for the lights, which seems to work well -- these were the most expensive parts, but you need to have a bright light! Two pairs of LEDs are spaced 6.5cm apart - the average distance between human eyes. My prototype runs on a 6V camera battery which was chosen for its small size.

To use the Electro-Hallucinator, just hold it about 5-10cm in front of your closed eyes. The type and intensity of visual artefacts can be changed by moving your head and eyes, etc. just as with the Dreamachine. Experiment!

Kevin S. Meredith

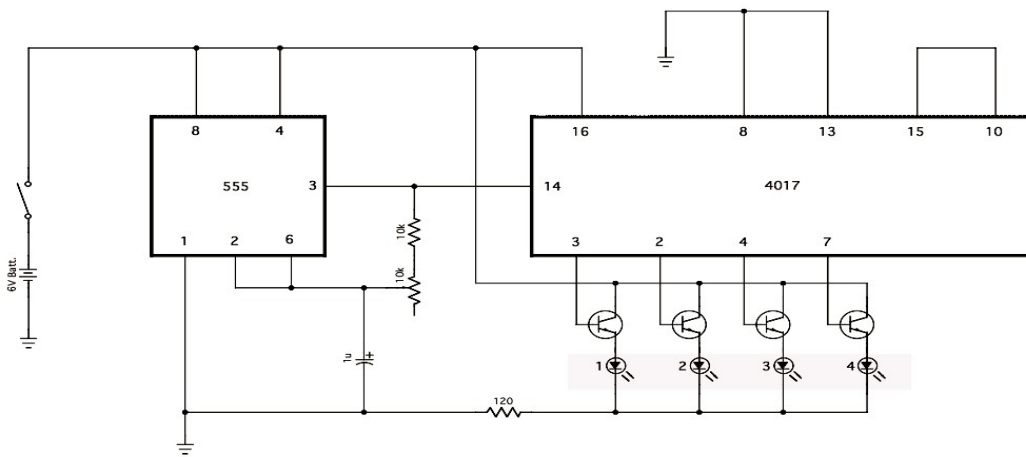

# coolcat's dream machine plan with a fan

<http://snap.to/williamsburroughs>

i made this as an alternative to making a dream machine that requires a turntable. since i couldn't get a turntable, i made a d. machine with a fan motor. i have recently modified it so the cylinder is suspended, see version 2 at the bottom of the page.

for version 1 you need :

- 1 small (about 8-10" diam. of blades) fan
- a bucket somewhat smaller than fan, plastic
- 1 sheet very thick cardboard
- 1 sheet thinner cardboard
- clamps
- masking tape
- duct tape
- black spraypaint (optional)
- ruler
- tape measure
- x-acto or utility knife
- t-square
- compass
- scissors or wire cutters
- 1 free-hanging light socket or small desk lamp
- 100 watt bulb



take apart the fan. remove the front and back, and detach the motor. use the scissors or wire cutters, or anything you think will work, to take off the blades of the fan.

Now, use the bucket, fan casing, or both to make a platform on which the motor can stand. the part the blades were attached to must be elevated.

use the compass to draw a circle on the thick cardboard, about the diameter of the fan. if there is a knob/pin-type thing coming out of the part the blades were attached to on the fan, cut a hole in the center of the cardboard the same size. Push the cardboard on, and you have a makeshift turntable. tape it securely in place. If there is no knob, locate the center of the piece, and glue, tape, somehow attach the disk onto the fan.

before you get to the actual dream machine part, you should make your base as sturdy as possible. use duct tape (or something of that nature) to attach all the pieces. make sure the plug comes out in a convenient place. you may want to spraypaint the whole lot black, it looks better that way.



now the harder part. calculate the circumference of the circle, and measure out that much of the thinner cardboard. (thin means thinner than the thick cardboard. it should still be very opaque.) Add about an inch or so for overlap. this is the length of your cardboard, you can cut off the rest. the height is up to you. i made mine about a foot (30.48 cm) high.

draw lines parallel to the length about an inch and a half down from the top, and up from the bottom. this will be the parts with no holes, for stability. now, divide the rest (horizontally) into five equal parts.

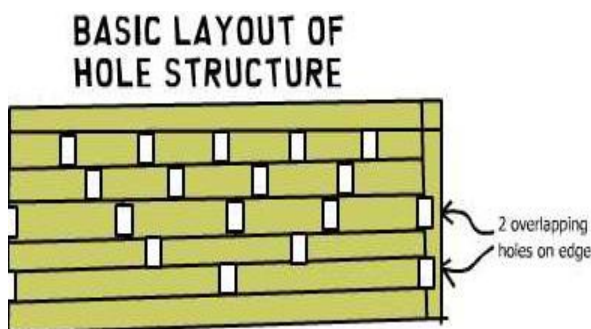

the rest is very much like brion gysin's plans. i have reduced the number of holes because the fan motor will spin much faster than the record player. this is just an example, i encourage anyone trying this to experiment. the top row, divide vertically into six equal segments. these will be in the middle of the holes you put in that row.

divide the second row from the top into five equal segments, the third row down into four segments and so on: fourth row: three segments; fifth (bottom) row: two segments.

now you must mark the holes on the cardboard. mine are about 1/2 inch wide x 1 inch tall, but you may want to change them depending on the size of your machine. for each of the vertical marks on each row, you will draw one of these rectangles. then add one rectangle to the end part of the third and bottom rows, on the overlap part. you will also have to put a half-rectangle at the beginning of these rows, for them to fit over one another.

once you are happy with the size and placement of the rectangles, cut them out with the knife.

fold the whole piece of cardboard into a cylinder shape, the extra holes should overlap. now use strong glue to stick them together, and clamp the edges for an hour or so.

you may want to run a thin piece of tape along the seams now. now spraypaint the cylinder black, if it wasn't black already.

using thin tape or strong glue, attach the (dried) cylinder to the thick cardboard disk.

find some way to suspend a light socket or small desk lamp (100 watt bulb) in the middle of the cylinder. make sure the base is steady, and on a flat surface (such as a tabletop).

now plug in the fan motor and the bulb. switch the other lights in the room off, and sit with your face close to the machine. make sure the fan motor is running on the lowest speed. close your eyes and watch the machine.

one could experiment with different sizes, shapes, and or amounts of holes to make many interchangeable cylinders for the machine.

this is a VERY rough dream machine, i welcome all feedback and suggestions for improvement. i would also love to hear about anyone's experiments or experiences with this or any other dream machine. i can be reached at [callmeburroughs@hotmail.com](mailto:callmeburroughs@hotmail.com)

## Modified Dreamachine (version 2)

additional materials:

- four dowel rods
- lots of duct tape
- metal ring for making wreaths, available at craft stores (or similar round thing)
- extension cord
- light socket
- small box

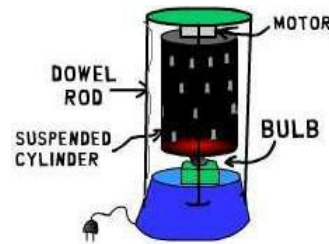

after having some trouble with it wobbling, i modified the above dreamachine. the cylinder is now suspended over a stationary base, where the light is. This way, you don't have to bother with hanging the light, and everything is plugged into an internal extension cord so there is only one plug.

first, follow the directions above to modify the fan. then, attach the motor to the cylinder as stated above. instead of attaching this to the base, attach it upside down to the wreath-thing. use copious amounts of duct tape to hold it securely. make the base like the one above. but make the top part open, so the light bulb can stick up from the base.

use the box to make a stand for the light socket. plug the socket into the extension cord. now you must cut four holes in the edges of the base. my fan base had holes where the screws were, which worked well to stick the dowel rods in. i used 3/4 inch dowel rods. glue these in securely, then duct tape the whole mess.

now you must similarly attach the dowel rods to the wreath thing. make sure that the cylinder, when suspended, spins freely and does not touch the rods. securely tape it with more duct tape.

now, take the cord from the motor and tape it so it goes down a dowel rod toward the base. cover this in tape. the cord should go inside the base so you can plug it into the extension cord inside.

the bottom of the base should be easily removeable, i used a circle of cardboard taped to the bottom. this is so you can take it apart to change the bulb. otherwise you can tape the thing up, paint it and try to make it look nice, leaving only the one extension cord plug to plug in. my on/off switch ended up on the top of the machine, which worked nicely.

any questions/comments, email me: [callmeburroughs@hotmail.com](mailto:callmeburroughs@hotmail.com)

# Dreamachine Plans of Brion Gysin

Noah [noah@noah.org](mailto:noah@noah.org)

<http://www.noah.org/science/dreamachine/index.html>

"Had a transcendental storm of colour visions today in the bus going to Marseilles. We ran through a long avenue of trees and I closed my eyes against the setting sun. An overwhelming flood of intensely bright colors exploded behind my eyelids: a multidimensional kaleidoscope whirling out through space. I was swept out of time. I was out in a world of infinite number. The vision stopped abruptly as we left the trees. Was that a vision? What happened to me?"

Extract from the diary of  
Brion Gysin  
December 21, 1958

Brion Gysin found the explanation for this unusual experience a few years later when William S. Burroughs lent him a copy of *The Living Brain* by Dr. W. Grey Walter. Dr. Walter was a neurophysiologist and an early researcher into the nature of brain waves and corresponding brain function. Ian Sommerville, a friend of Gysin and Burroughs, had also read the book. Sommerville decided to build a machine to reproduce the flickering effect that Gysin had described. On February 15, 1959 Sommerville wrote to Gysin from Cambridge,

*"I have made a simple flicker machine. You look at it with your eyes shut and the flicker plays over your eyelids. Visions start with a kaleidoscope of colors on a plane in front of the eyes and gradually become more complex and beautiful, breaking like surf on a shore until whole patterns of color are pounding to get in. After awhile the visions were permanently behind my eyelids and I was in the middle of the whole scene with limitless patterns being generated around me. There was an almost unbearable feeling of spatial movement for a while but It was well worth getting through for I found that when it stopped I was high above the earth in a universal blaze of glory. Afterwards I found that my perception of the world around me had increased very notably. All conceptions of being dragged or tired had dropped away..."*

From Sommerville's description of the flicker machine Brion Gysin built the Dreamachine in the early 1960's in the Beat Hotel on the rue Gît-le-Cœur, Paris. Gysin obtained a patent in 1961. The results of the experiments were published in the arts periodical of Olympia, Number 2, January 1962.

The Dreamachine consists of a cylinder with holes in it attached to a record-player turntable. In the middle of the cylinder sits a light bulb. The turntable is set to spin at 78 RPM. Subjects sit in front of the cylinder and close their eyes. The light shines through the holes in the spinning cylinder and flickers on the eyelids. The light flickers at a frequency of about 20 Hz which is similar to the frequency of Alpha brain waves which are associated with a non-aroused brain.

# Plans

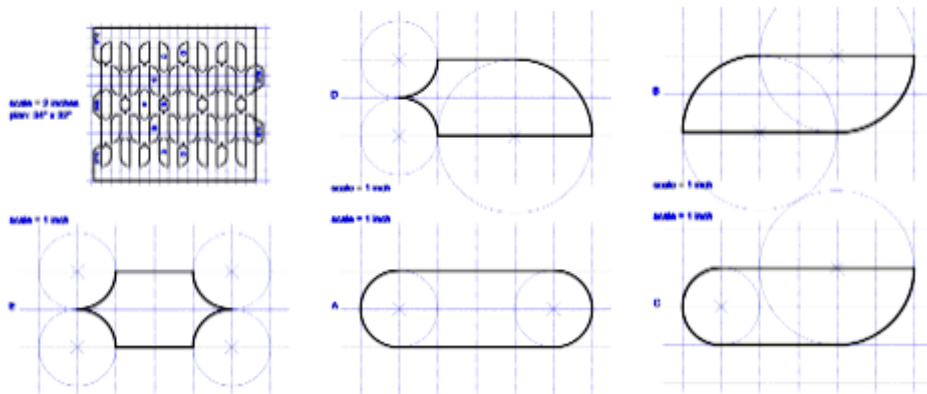

## Materials

- 34"x32" piece of heavy paper or cardboard for the Dreamachine light-shade. You should use a material that is stiff, but flexible enough to be rolled into a tube with the ends glued together.
- 16"x12" piece of heavy paper or cardboard for making templates. This will be cut into five 8"x4" cards for making templates.
- 78 RPM record-player turntable.
- A bare hanging light bulb. Wattage will vary depending on how bright a light you prefer. Try 15 to 50 watts.

## Construction

1. Photocopy the five templates (A, B, C, D, and E) and then paste the copies onto 8"x4" cards cut from the heavy template card stock. Then cut out and discard the designs to form the template cards.
2. Divide the light-shade paper into a 2-inch grid as shown on the overall plan.
3. Trace the template designs onto the light-shade paper following the grid sequence from the overall plan.
4. Cut out and discard the designs from the light-shade paper. These form the slots that the light will shine through.
5. Cut and trim the two long ends of the light-shade paper to form the glue tabs as seen in the overall plan. Note that the pattern length should be just under 34 inches. When the pattern is rolled into a tube its circumference should be 32 inches since the tabs overlap.
6. Roll the light-shade paper into a tube and overlap the glue tabs. The tabs should be positioned on the inside of the tube, rather than the outside. Glue the tabs to the inside surface of the tube.
7. Place the Dreamachine light-shade on a 78 RPM turntable.
8. Suspend the light bulb 1/3 to 1/2 down the inside of the light-shade. The light should be in the center of the tube and not touch the edges.

## Using the Dreamachine

Turn on the light bulb and set the light-shade tube in motion. Dim the normal room lights so that most of the ambient light comes from the Dreamachine. Sit comfortably with your face close to the center of the tube. Now close your eyes. You should be able to see the light from the Dreamachine flickering through your eyelids. Gradually you will begin to see visions of flickering colors, amorphous shapes, and fields and waves of color. After a time the colors begin to form patterns similar to mosaics and kaleidoscopes. Eventually you will see complex and symbolic shapes; perhaps people or animals.

## Notes/Variations

This device will produce a flicker frequency of 20.8 Hz when rotated at 78 RPM. This device may be hazardous to people with epilepsy or other nervous disorders.

If you have trouble getting an old 78 RPM. turntable then you can make use of a 45 RPM. turntable by adding 12 extra columns of slots. This makes the pattern 24 inches longer and will result in a tube diameter of 17 inches. This is bigger than the platter of most turntables. You can either scale the entire pattern down by half or you can try placing an 18-inch disk on the turntable for the tube to rest on. The wider tube will produce a flicker frequency of 21 Hz when rotated at 45 RPM.



Animation: "First Dreamachine" [Daniel Gualda http://www.nqnreport.vze.com](http://www.nqnreport.vze.com)



# Dreamachine Manufacture

1011.ORG

<http://www.1011.org/>

[1011.org](#) | [index](#) | [Dreamachine](#) | [Artisanat](#) | [Interventions](#) | [Sound](#) | [Kode](#) | [Secretariat](#)

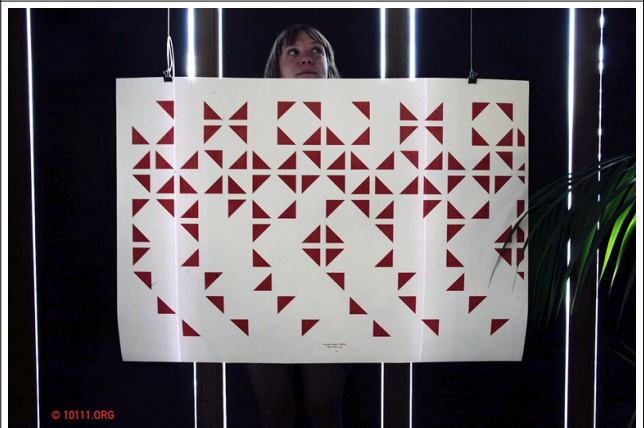
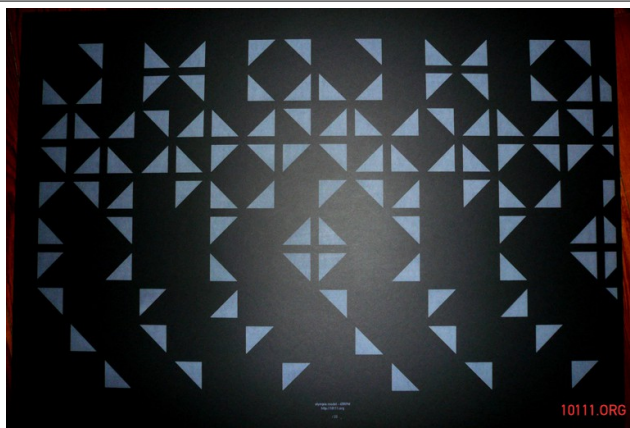
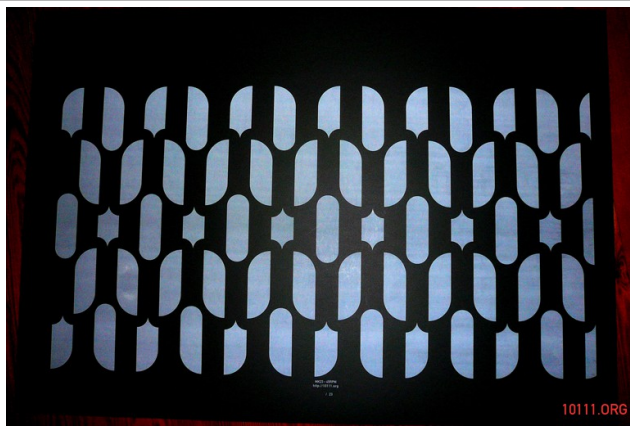

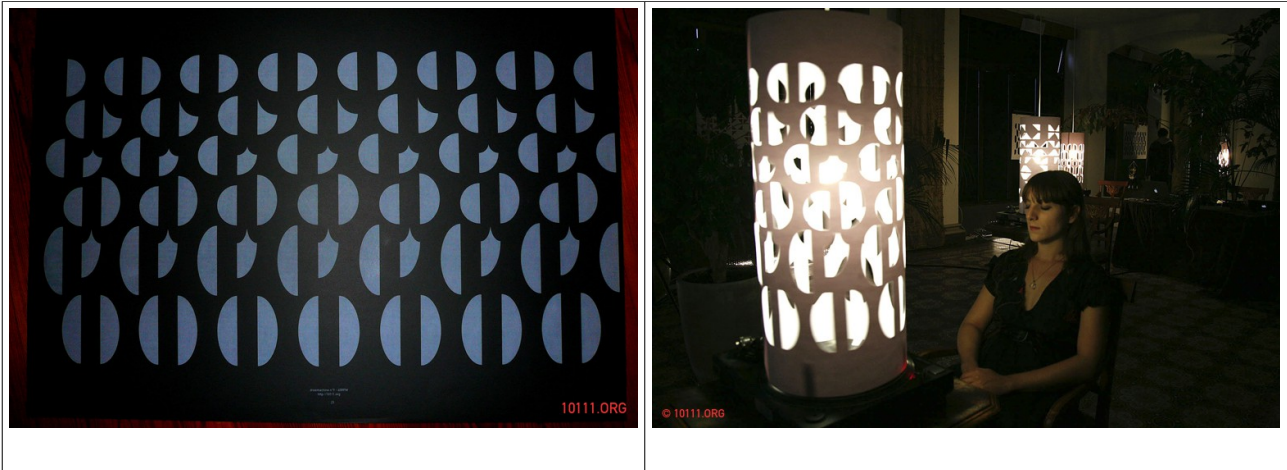

## assembly instructions

for the three models above.

0. Dreamachines are delivered rolled, printed side facing in. Roll it in opposite sense, printed side facing out. Leave it like that for a few hours in order to letting it take shape.

1. Cut the two vertical strips from the right+left edges of the sheet as shown on the picture below:

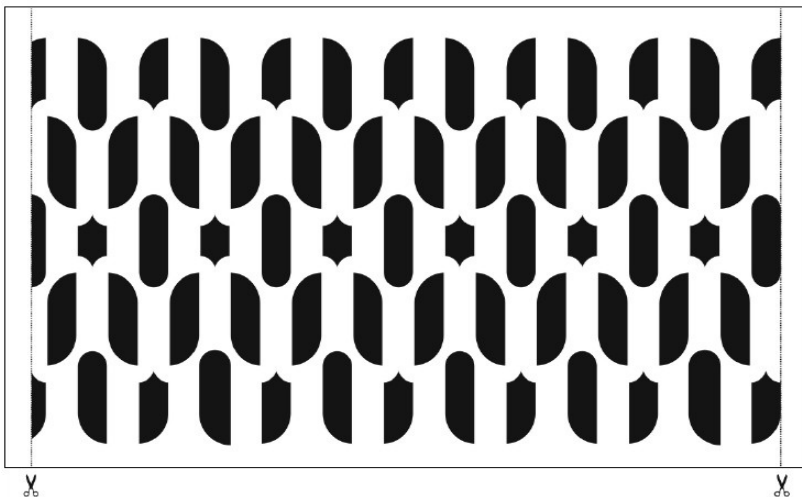

2. Cut out the printed shapes.

3. Roll the template to form a cylinder, overlap the two sides and make the holes match. Fix the cylinder with glue, paperclips or adhesive magnetic tape.

4. Use the previously cut strips to make "L" shaped supports. Place the Dreamachine centered on a useless LP and make some marks around the cylinder's circumference. Fix the "L" supports on the vinyl where the marks are (just a bit towards the center of the vinyl) as shown on the picture below:



5. Put again the Dreamachine on the vinyl, with the L-shaped supports inside. If that has been done correctly, the Dreamachine should be centered and properly stabilized. The supports will gently push towards the outside and keep the cylinder in place.
6. Put the Dreamachine on a turntable and set the speed to 45RPM.
7. Suspend a light-bulb inside the Dreamachine. Try and find out the best position for you (usually, 1/3 height from top is a good starting point).
8. Turn on the light-bulb and the turntable.
9. Sit comfortably in front of the Dreamachine, with your face 5-7 cm away, and close your eyes.

---

More data on vision of photisms and colors in  
[The Man of Light in Iranian Sufism](#)

by Henry CORBIN

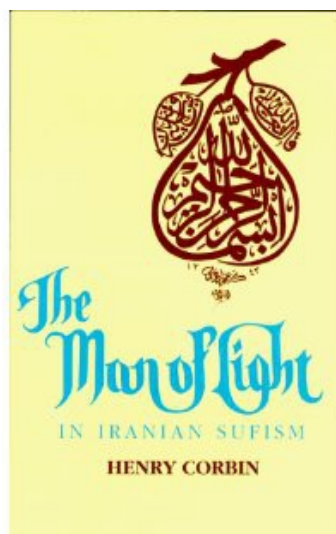

# Detoxification



Roger Holden

## Alternative, Affordable Treatment for Feline Leukemia The "Burroughs' White Cat" Challenges the Board

[whitecat23skidoo@hotmail.com](mailto:whitecat23skidoo@hotmail.com)

My name is Roger Holden from Lawrence, Kansas. I was a friend of William Burroughs. I am honored and graced that our friendship evolved into an artistic collaboration that was included in "Ports of Entry", his landmark 1996 artistic retrospective at the Los Angeles County Museum of Art.

Specifically, our collaboration was a series of 3D stereograms that were adapted from samples of his artwork (refer to "Ports of Entry: William S. Burroughs and the Arts" Sobieszek; page 149).

In 1993, William gave me "Porch", a stray cat who in a sickly, dying state wandered on to his front porch as if to ask for help. William with the help of Dr. Bradley, a brilliant and compassionate local veterinarian nursed Porch to lively health in 3 or 4 weeks. My good catfriend Porch subsequently lived with me until July of 1995 when he then passed on from the ravages of feline leukemia. His picture may be found at my celtic rock band's Uncle Dirty Toes website <http://www.forthrt.com/~dirtytoes/>

Currently, I am the caretaker of Marigay, "The White Cat", the familiar of William S. Burroughs. As presented by William, in the book Last Words, the Final Journals of William S. Burroughs; editor James Grauerholz, Marigay symbolizes the Searing White Light of Truth.

When as a gift from William, Marigay first entered my life in January of 1997 at an estimated age of 3 or 4 years, he was a tough 13 pound white cat with an immense territorial control instinct. When he was outside, the neighbors knew him as a bully cat whom thought of himself as king of the city block. Marigay disappeared the week of Williams' death and funeral (August of 1997). He had been picked up by the local animal "control" as a vagrant cat. I rescued him from the kitty prison and subsequently nicknamed him Butch. Now whenever he would go outside I would go out with him and monitor his locations.

In late May of 1999 Butch (Marigay) was chased under my porch by a German Shepard dog. It was only the next morning that I realized that he had been bitten and his health was declining rapidly. The prognosis by the veterinarian was that Butch would soon die from cat leukemia. His white and red blood cell count seemed hopelessly low. The doctor told me he had 1 to 3 months at the most to live. This was a devastating blow to me as he had all of his leukemia shots since 1996 and previous testing showed that he had no virus.

This time I was determined to see if there was any alternative treatment available which would help Butch. I would be heartbroken to see another catfriend given to me by William succumb so soon to the ravages of feline leukemia. The first thing I did was to treat him with traditional prescribed antibiotics to assist with the healing of the dog bite and its infection. I simultaneously searched the internet for any seeming reliable alternative treatment for feline leukemia. The first ones I found seemed to be complicated, involving needle injections, exotic pharmaceuticals and strict regimental administration. Those sadly would have been beyond my means to deal with. Then the breakthrough came. In my internet research I found a site which mentioned that "Flor Essence" [http://www.florainc.com/united\\_states/html/flor\\_essence.html](http://www.florainc.com/united_states/html/flor_essence.html) an herbal Essiac tea had been used to treat feline leukemia with apparent success. Essiac tea is an herbal combination presented originally to the modern world through an Ojibwa native American herbalist. It has apparently been used successfully for decades to fight and win over cancer, leukemia and other dreaded diseases. Here is a good website for information on Essiac tea in general. <http://www.essiac-info.org/> Flor Essence is a version of Essiac tea that I used for the treatment of Butch. The other versions of Essiac tea available may just as well produce equivalent results. It is my opinion that the "Flor Essence" Essiac tea has produced the miraculous results I will now report.

The antibiotics I gave Butch in late May and early June of 1999, no doubt in my mind, significantly helped to fight the dog bite infections. But while I was giving him the vet prescribed antibiotics, I was told by the same doctor that Butch's blood cell count was so low that he would not live past August 1999. A neighbor told me of a vet who performed acupuncture and chiropractic treatments on animals. I took Butch there immediately for such a treatment from Dr. Van Petten. Web info: <http://www.barrelhorses.com/JEFJO/>

Dr. Van Petten told me that the procedure he undertook might help to stimulate Butch's kidneys and liver. In addition I gave Butch pinches of Vitamin C (calcium ascorbate I was told would digest appropriately in cats stomachs) in his breakfast. His diet was also changed to a prescription diet.

All in All I would have to say that the Flor Essence seemed to me to be the catalyst for his remarkable recovery, with the other things I just mentioned, lending assistance to his treatment. Butch's blood count almost reached normal levels within three weeks. By August 1999, they were essentially normal. He has been in remission ever since. He runs up a flight of stairs in one second!

I started by giving Butch 2 tablespoons of Flor Essence everyday mixed in with a spoonful of his canned food. After August 1999, I cut down to apx. 1 tablespoon of Flor Essence a day. Now his daily maintenance dose is about a half a teaspoon everyday. Over the past year and a half there has been a regurgitation or throwing up of his meal, once every other month or so, but the cause of that could be most anything. I am positive that had William still been alive that he would have wanted the word to get out on this possible effective and affordable treatment for the horrible ravages of feline leukemia. The fact that William had bequeathed "the White Cat" to be his "familiar", is reason enough for his fans everywhere to take this news with serious interest. Perhaps there are implications for human Leukemia treatment as well. Perhaps it is imagination and just the luck of the draw. Perhaps it is Magic.

Postscript: As Izzy reminded me, love is the great medicine for our ill animal companions. I can certainly testify that Burroughs LOVED his cats and that I in turn LOVE the White Cat. William put it best in his last written words, "Love? What is it? Most natural pain killer what there is. LOVE"

Roger Holden [whitecat23skidoo@hotmail.com](mailto:whitecat23skidoo@hotmail.com)

Wednesday, May 14, 2003 6:18 PM

Hi Izzy,

I want to thank you for the privilege of having a web page on your great site which allows the researching of information on Essiac Tea and its possible benefits in the treatment of Feline Leukemia. Butch Burroughs has survived 4 years now with this disease which was originally diagnosed to be fatal after no more than 3 months. I still give him a dash of the Tea mixed in with soft food every morning. Last year Butch had a serious bout with Pancreatitis which was successfully treated with orthodox veterinarian methods. Butch is currently in fine health.

I hope all is going well for you,

Thanks,

Roger Holden [whitecat23skidoo@hotmail.com](mailto:whitecat23skidoo@hotmail.com)

---

From: "Roger Holden" <[whitecat23skidoo@hotmail.com](mailto:whitecat23skidoo@hotmail.com)>

To: <[izz@inter-zone.org](mailto:izz@inter-zone.org)>

Sent: Thursday, March 31, 2005 8:48 PM

Subject: Margaras (Marigay) The White Cat has passed on

Izzy,

It is my sad task to report to you that Margaras "Butch" Burroughs, the White Cat has passed on to the Western Lands to be with William as of the evening of March 29. Butch's feline leukemia finally won over his strong fortitude and stamina. This current bout encompassed a serious declining period of about three weeks. He was put to sleep before the possibility of any agonizing pain would accompany his impending death.

Having been previously diagnosed in May of 1999 with an assured death to come from this dreaded disease within in a three month period, his survival in a good natured healthy state until just recently (with the exception of a bout of pancreatitis he overcame) should stand as testimonial to the "searing white light of truth" of questioning authoritative control mechanisms, whether medical or otherwise.

Thank you so much for your support over the years for getting the "word" out on this. I will follow up in the next few months with an expanded essay which will include new ideas for alternative treatments.

Roger Holden

---

# Apomorphine cure

Ian Sommerville

Apomorphine is so called by the chemists in order to indicate that it is synthesized in some way from morphine as base. It has, however, very different properties to morphine; it does not give sensations of pleasure, nor has any case of addiction to its use ever recorded. It has been known for some time as a reliable emetic, being easily dissolved in water and administered by hypodermic injection.

It was for this property as an emetic that apomorphine was kept on hand on the clinic begun, several decades ago, by Dr. John Yerbury Dent of London; a clinic devoted to the treatment of alcoholics and addicts to other drugs. Dr. Dent also experimented with apomorphine as part of an aversion treatment for addiction. However (and this point is crucial) he found that many of the distressing symptoms attendant upon cure were alleviated by apomorphine even when no vomiting was induced.

In our waking state the body builds up stresses and metabolic disturbances which are regularized while we sleep. There is, in fact, a part of the brain which works harder during sleep than during wide awake life. This regulatory center Dent termed "the sleep center", and it was his conclusion that the action of apomorphine is to stimulate this center and give it greater powers.

The abrupt withholding of a drug from someone who is addicted to its use gives rise to the severe stresses and metabolic disturbances known as "withdrawal symptoms", and the natural regulatory functions of the body are inadequate to deal with them. However, potentiated with apomorphine, a much wider compass of disturbance can be dealt with, to such an extent that cure loses much of its nightmare aspect.

Dr Dent further elaborated the use of apomorphine and made it the basis of a long and successful practice devoted to the study and cure of addiction. During his method of cure vomiting is only essentially induced twice in the patient : these occasions being necessary to obtain a measure of the patients level of tolerance to the drug. It cannot be overemphasized that the apomorphine treatment is not an aversion treatment, but is method of stimulating the body's natural resources in their capacity to normalize stresses and metabolic disturbances, in this case the withdrawal symptoms.

The smallest dosage of apomorphine which will induce vomiting varies considerably with the individual, from as little as one fortieth of a grain up to twenty times as much, though this latter is unusual.

In this first steps this apomorphine cure parallels other known methods of treatment. Firstly, the addict must want to be cured and should say so, patients brought to a clinic against their will, by relatives, etc., do not make good subjects unless they can first convince themselves and the doctor that they wish to be free of their drug. Secondly, the patient is hospitalized in a cheerful nursing home atmosphere, day and night nursing together with frequent visits by the doctor are necessary.

The usual medical tests are presumed; addicts are often weak on arrival so the use of vitamins and a proper diet to rebuild bodily condition are assumed throughout the cure.

## Notes (A) The use of apomorphine.

1. Finding the threshold dose :

Throughout the cure apomorphine is injected every two hours. One twentieth grain is the standard initial dose. This is progressively arithmetically increased by one fortieth grain per injection until a dosage is found which induces vomiting (the threshold dose).

## 2. Maintaining concentration :

Suppose that the threshold dose is found to be  $x$  grains, then the subsequent doses for the next four days (approx) are each of  $1/2x$  grains.

## 3. The new threshold dose :

The first two stages above often cause a change in the patients tolerance for apomorphine. After stage 2. each injection is progressively increased or decreased by one fortieth grain at a time until the new threshold dose,  $y$  grains, is found. The treatment continues with two hourly injections each  $1/2 y$  grains, the frequency of injection tapering off toward the end of the cure, usually ten days or so.

## 4. Post-cure use :

A patient cannot be considered completely cured until roughly one month after beginning treatment. After the initial ten days described above he should always have to hand sub-lingual tablets of apomorphine in the event of distressing symptoms arising.

## 5. General :

After an injection of apomorphine vomiting will occur within ten minutes or not at all. The above schema is not of course completely rigorous; it is for the doctor to decide whether vomiting is occurring because of the apomorphine or is a withdrawal symptom. Basically the idea is to maintain as high a concentration as possible of morphine in the patient for an extended period.

### Notes (b) The use of apomorphine (or the drug addiction in question)

In its capacity as a metabolic regulator apomorphine considerably reduces the severity of withdrawal symptoms. However, and specially in the first few days of cure, morphine must be allowed to the patient in the event of severe symptoms breaking through. As a general guide it will be found that quite minute doses of morphine will be adequate, totally over the entire period to much less than the habitual previous daily dose.

Apomorphine is usually available in one twentieth and one tenth grain water soluble hypodermic tablets. It is also available in France (made by Chabre) as sub-lingual tablets. Whereas these latter can be used to effect a cure they are not so rapid or precise in action as the hypodermic tablets, they are, however, very useful to the patient after leaving the clinic as a standby which can be self administrated.

In the case of say, addiction to morphine, the only drugs given during the treatment are apomorphine, minute doses of morphine and possibly vitamins and the like. It is to be emphasized that sleeping pills, barbiturates, tranquillizers, etc. are contraindicated. They have no part in the cure and only serve cloud knowledge of the patients progress. (Dent found that addiction to barbiturates was the most difficult to break as well as giving the most unpleasant symptoms, before and during the cure.)

The above notes are based upon talks with Dr Dent himself during the autumn of 1961, some months before he died. He was much distressed that, apart that in those clinics where it was used, doctors stubbornly maintained that it was an aversion treatment, thus only serving to block its real progress.

Ian Sommerville,

London, September 1967.



## Letter from William Burroughs and James Grauerholz

July 15, 1983  
PO Box 147  
Lawrence, Kansas 66044  
USA

Dear Baudron:

Many thanks for your communication and for your efforts in the apo-morphine cause. Doctor Dent who was the sanest and least paranoid of men, could not help but see a conspiracy on the part of the medical establishment, which is, In America at least, very much under control of the Narcotics Dept., to suppress the apo-morphine treatment for addiction. And I have a thick file of inquiries, attempts to interest doctors and researchers, all ending in a dead end. Some of the inquirers even lost their jobs as a result of advocating at least a ~~trial~~<sup>trial</sup> of the apomorphine treatment. It is also to be remembered that synthesis of the formulae could yield compounds with a much more potent regulatory ~~activity~~<sup>activity</sup> and the ~~nausea~~<sup>nausea</sup> factor could be eliminated.. Doctor Dent could not stress too heavily and too often that this is not an aversion treatment. I finally decided that a very potent vested interest does not want to know about a real cure for addiction ~~any~~ any more than they want to know about a cure for cancer. So I am not surprised at the run-around you got from the experts. The alcoholic neurosis indeed, what rubbish. Doctor Dent said the alcoholic's neurosis is that he drinks too much. Tell that to a psychiatrist.

Doctors are, by and large, drastically limited in outlook. They have read all there is to know on any subject and that is that. Anything outside their knowledge cannot be worth hearing about. So I really gave up years ago. Some doctors in Denmark still use the apo treatment but they clash with the psychiatrists.. In my opinion a substantial number of psychiatrists ~~should~~ be broken down to veterinarians<sup>h</sup> but that goes ~~for~~<sup>for</sup> the medical practice in general..

Interesting how large a part voice plays in psychosis. The patients who thought of words as parasitic entities. People who hear voices describe them as very loud and vibrant and they cannot believe that others do not hear the voices. They should be able to develop ~~mikes~~ sensitive enough to pick up subvocal speech.

Dear Isabel, & Jean-Louis:

19 July 83

Thank you very much for your long letter. The foregoing is William's response. I find that "Notre Agent au Bunker" is a good title translation. You know that Belfond has an edition of JUNKY; they would be OK for this book. Flammarion has PORT OF SAINTS and Bill Junior's KENTUCKY HAM. I guess Bourgois has declined? I did see "Desert Patrol", very good-looking.

Excuse me that I cannot write at greater length about the ideas in your letters -- which were fascinating. At the moment I am trying to catch up my other correspondence etc. But please do keep in touch; we both support your efforts to discover why apomorphine has been ignored, and -- for that matter -- whether as a scientific fact it is really as effective as William believes, and if so, how. We await news of ~~mm~~ your travels -- very best wishes,

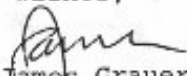
  
James Grauerholz

FOR the past ten years the Danish originator of Antabuse has been working on a modified version of an old British treatment: pre-ermetic apomorphine mixed with L-dopa. The drunken patients think it's a miracle.

Doctors are more cautious. ANNE-LISE GOTZSCHE has tried the drug in a Swedish health service clinic and confirms that it certainly puts you off drink while you are taking it.

# The 'sober-you-up' drug

## Apomorphine makes a comeback in the treatment of alcoholics

APOMORPHINE re-presents one of the best and most intensively studied drugs in recent psychopharmacology and biochemistry, according to Dr J. Scheel-Kruger, of the Psychopharmacological Research Laboratory at the St Hans Hospital in Roskilde, Denmark's leading mental hospital.

My inquiries among British alcoholics experts would make this a somewhat surprising statement. Scheel-Kruger is the author of a 40-page review of the most recent apomorphine developments and the latest researcher to jump on a small band-wagon of doctors who are convinced that apomorphine is the answer to alcoholism and drug addiction.

On the laboratory side this group is led by Professor Arvid Carlsson, head of the Department of Pharmacology at Goteborg University in Sweden and a man commonly

known as 'the sober-you-up' drug. The drug has been combined with levodopa and used in the treatment of Parkinson's disease and as such is once more gaining respectability.

Its use in the treatment of alcoholics and drug addicts, however, has become a subject of heated and sometimes acrimonious debate in Denmark. The controversy centres on the work done by the originator of Antabuse, psychiatrist Dr Oluf Martens-Larsen and his colleague Professor K. A. Lock Halvorssen, a one-time hormone researcher at the State Serum Institute in Copenhagen.

### Clinic

Between them they run a clinic for addicts in Copenhagen, and Dr Martens-Larsen also practices at the Alkohol-polikliniken in Helsingborg in Sweden where day treatment is given to Swedish health service patients. The new use of the drug has

abstinence. And there are difficulties about conducting conventional double-blind trials because of the need to find a suitable individual dose. There have been difficulties too about patenting the new development of the drug. In its simple version apomorphine and the various other drugs used concurrently could, theoretically, be mixed by any chemist. Lastly, as so often happens, there have been 'political' problems.

The treatment of alcoholism and addiction in Denmark is dominated by psychologists and sociologists who, perhaps because of pronounced left-wing political views, seem strongly opposed to a biochemical and pharmacological approach to the problem which they regard as a 'cultural and psychosocial' ailment.

While the drug addicts themselves queue up for apomorphine treatment both in Sweden and Copenhagen an academic battle continues, Danish-style, across the news-

per cent had a 'moderate' consumption of morphine and were able to hold down a job. The rest relapsed. Up to 70 per cent of the patients at various stages of the treatment reported an absence of craving and the usual intensification of withdrawal symptoms was reduced. This, however, was not a controlled trial due to lack of official financial support.

### Pharmacology

Pharmacologically apomorphine is now emerging as extremely complicated and the effects are strongly dose-dependent. Although apomorphine is technically a morphine derivative, the effects are also in many ways exactly the opposite. Generally speaking apomorphine is not a narcotic, it is not addictive. It has no pain-killing properties. The treatment is not aversive therapy.

The working hypothesis among the Scandinavian re-

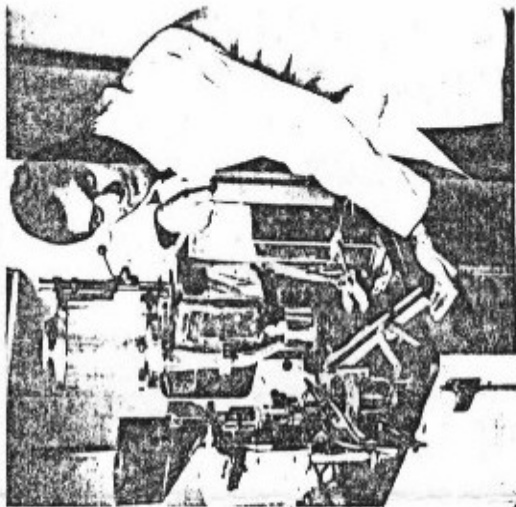

Pharmacist Nils Draebye: he has developed the capsules which contain a combination of levodopa and apomorphine.

phine, which have a central depressant and sedative effect, cause a blockade of the postsynaptic dopamine receptors and decreased transmission. Apomorphine, by contrast, will stimulate the postsynaptic receptors in high doses and the presynaptic receptors in low doses. Thus you only need

withdrawal symptoms a aggression. Whichever way one argues the case pharmacologically and it seems to me that there is a lot of arguing still to come. — one prominent effect of a morphine in all these diseases is the 'quick, temporary diminution or abolition tremor' that the Blycke-

Swedish said a man commonly regarded as one of the world's most respected pharmacologists. A hard-headed and reticent Swede, Carlsson took a long time convincing, though he has now himself published research on the subject.

The drug, first used at the turn of the century in large doses as a vomiting agent, has had a curious history and to this day remains begged down in a medico-political soup of old misconceptions and clinical problems. Most recently

new use of the drug has nothing to do with aversion therapy. Very small doses are used either as subcutaneous injections or taken as capsules with the dose tailored to the individual patient to find the most effective pre-emetic level. It is also claimed that apomorphine has a healing effect on the nervous system. In small doses it quite simply abolishes the craving for alcohol, while the effect lasts.

There is disagreement about its effect on long-term

Danish-style, across the newspaper pages.

Apomorphine was first used in the treatment of alcoholism in 1909 by a certain J. E. Tompkins who found it remarkably effective in controlling delirium. The following year it was recommended both in "The Lancet" and in the "New York Medical Journal" by Dr C. J. Douglas who wrote: "It will produce sleep in a few minutes even when the patient is suffering from the wildest delirium."

Apomorphine was next taken up in 1934 by the late Dr John Dent, former editor of the "British Journal of Addiction". In 1944 he wrote in "The Medical Press and Circular": "With the help of apomorphine the morphine-on-heroin addict can be entirely cut off from his drug of addiction in three days without any serious deprivation symptoms developing, and the apomorphine itself can be left off during the next three days."

During the second world war apomorphine was rediscovered yet again, this time in Switzerland by army surgeon Dr Harry Feidmann, now a lecturer in neurology at the University of Geneva. He found that he could sober up drunken soldiers in a matter of hours with the drug. (Incidentally, Dr Martensen-Larsen has done the same in Sweden to the amazement of the police on a number of occasions when alcoholics walked in from the street in such a violent state that the law had to be called in).

The most recent development in Denmark is that Lock Itallvorsen and Martensen-Larsen have begun treating heavy drug addicts. Two series of 50 patients have been reported, both treated with apomorphine only.

In the latter trial 30 per cent were reported cured, 10 per cent partially relapsed, and 20

among the Scandinavian researchers is that both with alcoholics and drug addicts there are certain disturbances in the dopaminergic centres which are degenerative in Parkinson's disease but mainly functional among patients suffering from addiction and possibly a variety of other conditions such as anxiety neurosis.

In Parkinson's disease, where there is a hypofunction of dopamine, apomorphine has been found to replace the loss of dopamine, while in the other cases it is a question of reducing dopamine hyperactivity. Paradoxically, from the work now done at Professor Arvid Carlsson's laboratory in Sweden, it seems that the mechanism is initially the same.

In more detail, apomorphine — when given in small doses — reduces the turnover of dopamine through a kind of back-coupling effect. The drug activates the presynaptic receptors in the medulla oblongata and the basal ganglia system, causing dopamine to do a U-turn and return to the original nerve ending. The result is a decrease in impulse flow of the dopaminergic neurons as well as a decreased "real" release of dopamine for neurotransmission. This is the case with alcoholics and drug addicts. In Parkinson's disease it is thought that apomorphine further replaces dopamine.

The interaction between apomorphine and morphine is more complicated. Once again the effect depends on the dose. Morphine in low doses produces a stimulating effect and euphoria because — according to Scheel-Kruger — the release of dopamine from the presynaptic nerve terminal is stimulated and increased. This is linked with a blockade of morphine at the presynaptic receptors. On the other hand, high doses of mor-

the presynaptic receptors in low doses. Thus you only need a low dose of apomorphine to "mimic" the sedative result of a high dose of morphine.

Moreover, the small dose of apomorphine enables the hypersensitive postsynaptic receptors to recover in a much shorter period of time than other drugs now used such as haloperidol or methamphetamine (Primperan). According to this school of thought it is also this hypersensitivity which is linked with narcotic craving, with morphine, levodopa,

75%

fewer coronary events in older outwardly healthy patients!

Long-term trials show that the incidence of first coronary event (myocardial infarction or new angina) can be reduced by Atromid-S. The earlier "at risk" patients are identified and treated, the greater the protection.

In the prevention of ischaemic heart disease

Atromid-S

the sooner the better

References: 1. Kravco, L.R. & Kober, G.J. (1977) Journal of the American Medical Association 239, 1465-1471. 2. Berg, T.B. & Ravid, B.M. (1977) Medical Science 82, 3469-3475. 3. Dewar, H.A. (1977) British Medical Journal 4, 167-175. 4. Over, M.J. (1978) British Medical Journal 4, 775-784.

References: 1. Kravco, L.R. & Kober, G.J. (1977) Journal of the American Medical Association 239, 1465-1471. 2. Berg, T.B. & Ravid, B.M. (1977) Medical Science 82, 3469-3475. 3. Dewar, H.A. (1977) British Medical Journal 4, 167-175. 4. Over, M.J. (1978) British Medical Journal 4, 775-784.

decarboxylase-inhibitor, such as benserazid (Madopar, Roche) or carbidopa (Sinemet, Merck Sharp and Dohme). In other words, Sinemet is used together with apomorphine.

In some versions ascorbic acid has also been added to aid absorption. The mechanism is not quite clear, but it is thought that the drug bypasses the liver and is absorbed directly into the blood at the top of the stomach and that the effervescent action of ascorbic acid aids this process. Food plays a part as well in absorption. The drug is more effective if taken immediately after a meal, particularly after food high in fat and protein. Cheese may increase the effect of a single capsule several times over.

The drug is more effective in the morning than later in the day. Some researchers think that apomorphine stimulates the hypothalamus and the endocrine system, more specifically growth hormone. Clinically normalisation of both menstrual and sexual function has been noted — in fact it has been noted as a not always welcome 'side effect' in male alcoholics who have complained of penile erection.

Lastly, the drug has no effect on the actual alcohol level in the blood.

Apomorphine is not a 'miracle drug' which at a stroke will cure all hangovers, prevent all drunken driving or help you to drive dead drunk without detection, nor a chemical gimmick to take before the next all-night party.

Nor is the drug easy to use. It has a sedative effect — and has been described as a 'superior tranquilliser' — and while that also may be useful, it is certainly not advisable to drive while you are undergoing the treatment. It may make the patient drowsy, though less so when combined with levodopa. Too much, of course, will make the patient vomit.

The main effect at first — apart from completely abolishing the craving for alcohol — is sedative but without euphoria. There have been no cases of addiction to apomorphine. On the contrary, the tendency is for the patient to require or want less of the



● Psychiatrist Dr Oluf Martensen-Larsen, the originator of Antabuse. He has been working on an updated version of the old apomorphine treatment and was the first to combine the drug with levodopa in the treatment of alcoholism and drug addiction.



Professor Arvid Carlsson, head of the Department of Pharmacology at Goteborg University. He took a long time convincing, but is now a leading proponent of apomorphine therapy.

drug as treatment progresses.

At the Swedish day clinic in Helsingborg treatment is started with subcutaneous injections of 0.2, 0.3 mg apomorphine, possibly as much as 1 mg or even 2.5 mg depending on the circumstances.

It is not unusual for the patient to feel completely bright, sober, normal — and hungry, by lunchtime on the first day of treatment. Injections may be continued for a couple of weeks, and thereafter the patient is maintained on capsules containing anything from 5 mg to 60 mg. The dose is gradually reduced over a period of time and the patient is seen on an out-patient basis once a week.

Letter to Dr Martensen-Larsen

Isabelle Aubert-Baudron

March 11<sup>th</sup> 1987

Dr Oluf Martensen-Larsen  
Copenhagen  
Danemark

Sir,

Your address has been communicated to me by the Royal Embassy of Denmark in Paris which I had written to in latest December, about an article published in 1976 in a medical review, "Doctor", concerning the treatment of alcoholics and drug addicts by a cure of apomorphine.

I am a nurse working in a psychiatric hospital and am doing researches about the apomorphine cure which was used by Dr John Dent in England. As far as I know, this cure is unknown to the French medical area, the only use of apomorphine for alcoholics being the aversion treatment, which has nothing to do with my research. The only precise informations I got from a medical source come from this article published in "Doctor". At this point, I would like to get the following informations :

1. Do you confirm the informations about the cure contained in this article ?
2. Do you keep using this cure and do you consider it leads to positive results for the patients, alcoholics and addicts ?
3. What is the protocol of the cure you use (doses of apomorphine and other medicines combined with it) and how long does the cure generally lasts to be effective ?
4. Does the assertion considering apomorphine as a metabolic regulator seems to you justified ?
5. As a psychiatrist, do you use a psychotherapeutic treatment with the medical cure or do you think this approach is useless ?
6. Do you know if this treatment is used in other countries in Europe or if attempts have been tried in that sense?
7. Are there aspects which should not be neglected in an eventual attempt to apply and diffuse this cure in France or eventual difficulties which could arise from its application ?

I would be extremely glad to have your point of view about all this as you seem to me the most qualified person in this domain to speak about it. The aim of my research is to gather a record as complete as possible about this cure and my previous attempts have revealed rather fruitless. From my side, if I can be of any help, I shall be glad to do my best. I thank you for the interest you may be susceptible to bring to my research.

Yours' sincerely.

Isabelle Baudron

18. 3. 87

Dear Mrs Bandron  
 Avec remerciements, je suis tres enchanté de votre lettre. Je comprends le français, but I myself write better English - you can write me en français. I have known Dent and Feldman, the last died ~~there~~ 3 years ago he still fought for Apeomorphin - as I do - and my patients, but the claim that Bendocinaropines may have been easier for my silly colleagues to prescribe - so I also must treat Valium addicts with Apeomorphin. I will try to collect Reprints in English on Apeomorphin - but I certainly know a lot on the subject. Apon has also been used in France. One problem however has been

to make a stable prep. My Pharmacy can  
 (in Elsinore) Question 1: Yes

- 2: Yes
- 3: I will send you
- 4: Yes

Why not come to Denmark to read in my collection meet the "Apotheker" (in Elsinore) and talk to my patients and see what I do

Quite recently I appeared to be "very popular" <sup>why</sup> because of my research in Family psych - ground - quite unexpected for me - I wish I could help Apeomorphin - I might be able to, if I wrote a book with case stories

- 5: Useful, including their tense an anxiety ridden Patients (they also profit from Apeomorphin)
- 6: Yes: Hamburg (Dr Beil) and Moscow (a later an article)
- 7: only concerning the production - allergy could develop in the Pharmacy (the dust) but not in patients

Yours sincerely O. Martensen

## Jim Byer

### Opiates intoxication : Some suggestions from the doc (1)

From X

Iz

i need the doc's address. i got some problems with constapations and stomach pains in my lungs and stuff from this habit.

love

X

On Sun, 8 Nov 1998, BAUDRON Isabelle wrote:

Hi Jim,

here is a mail from X I got one hour ago.

He is probablygoing to write to you at the Interzone doc E-mail.

Iz

### Doc's answer :

Iz,

I'll be waiting for X to get in touch. In the meantime I could offer a few suggestions re opiate induced constipation.

I won't bore or disgust you with the machinations of the syndrome save to say that all opium derivatives may cause constipation with prolonged use. They can, in fact, cause bowel blockages that may prove fatal in some cases. It rarely happens but it should be acknowledged.

There are simple remedies but they can involve unwanted contact with doctors and the chance of a hospitalization. There are 'street' remedies that often work but their effectiveness can be unpredictable. You should avoid enemas and laxatives that irritate the bowel. Beware of so-called 'natural' laxatives derived from the castor-oil plant.

Grape jelly, oddly enough, can produce the desired results. Consuming several grams followed by a warm drink is the usual method. Another 'home' remedy that may or may not work, is to drink a few spoonfuls of Canola or Olive oil followed, once again, by warm water. Manatol, a sugar based food additive, is often sold as a baby laxative in Épe. By coincidence it is used to cut raw heroin prior to sale. A spoonful should do for starters. Over-the-counter 'stool softeners' are also a good option but don't over use them as they can cause a rebound reaction that could, as strange as it may sound, cause you to have an addiction to them. Why complicate the situation. Suppositories, most of these being a preparation of glycerol, are also of some benefit though their effectiveness is limited to the far end of the lower bowel. Severe constipation resulting in abdominal pain should be cause to seek professional assistance as this may indicate a blockage of the bowel. If this pain is accompanied by breath that smells of feces you may be facing an emergency and should seek assistance at once. Hope that covers it.

Jim

- (1) The doc, Jim, is an American doctor who also was a member of Interzone, and proposed to provide free counselling to other members who asked for it. An email had been created for people to write to him directly : Interzone doc: [the\\_doc27@hotmail.com](mailto:the_doc27@hotmail.com)



## Dr Dolophine (1)

### Report From Tasmania August 1998

[alhlee@netscape.net](mailto:alhlee@netscape.net)

Often when I read patients' reports in MA newsletter (a fantastic publication, by the way), I count my blessings that I live in Australia. There are varying degrees of quality throughout Oz as far as Methadone Maintenance Treatment goes, but generally it seems to be much much cheaper and far less institutionalized and entangled in red tape than the USA. While I have only had 1st hand experience of the program in Melbourne (Victoria) and Hobart (Tasmania), I have heard a lot of anecdotal evidence about other States. Currently I am on the program in Hobart, probably the best set-up MMTP in Australia. In Tasmania the MMTP is privatized, that is to say it works like this: each month or two I visit my GP, who is a licenced methadone prescriber, to talk about how the treatment is going for me and to renew my script for another couple of months. Each day I visit my pharmacy (drugstore) and have my dose, sometimes collecting take home doses. And that's all there is to it!!

Counselling is available should I feel a need for it, but definitely not compulsory. I can choose any licenced methadone prescriber as my GP and pick my dose up from any of a large number of dispensing pharmacies. I have to go to the same one each day, but can change to another pharmacy any time I wish. My dose costs me \$3.50 a day, and I have a credit account with the pharmacy which I pay monthly. The chemist and staff there are friendly and discreet. During the 3 and a bit years I have been on the program in Hobart I have never had to provide a urine sample, and certainly I would not be penalized for having taken an illicit substance. In fact, right from the start I have been honest with my GP, telling him straight out if I had used at all since my last visit, and far from expelling me from MMT, he would be more likely to increase the dose - If I felt this would help and he agreed. Both the doctor and the chemist have been very flexible with my treatment. I have a fast metabolism, and now split my dose of 120 mg per day into 2 doses - one I have at the pharmacy and one I take home for later that day, including 2 whole day take home doses for the weekend. Splitting the dose has really worked for me, before that I was just increasing and increasing the dose, because it just wouldn't last the 24 hrs. Since I split the dose I haven't had to increase once in nearly a year. Thanks to Methadone, I have a stable family life with my wife and child, a job that I enjoy and time on my hands to really enjoy life.

Anyway, what prompted me to put finger to keyboard was A.M. Black's letter "Wrong Dose" in the September issue. On a few occasions this has happened to me, but with entirely different and satisfactory outcomes. Once, I walked into the back room of the pharmacy to receive my dose (no windows or shutters!), The chemist handed it to me in the usual plastic cup. I glanced at it, and it did look less than usual, but I wasn't sure. When I got it in my mouth I was certain it was not correct. I said to the pharmacist, "uh Terry was that two squirts in that cup or only one?... only, it didn't feel like the right volume in my mouth." He stopped and thought and said " Hmm... actually, I'm not sure I did put two in", then measured out the remainder of what the dose should have been and gave it to me. Another time, I took my take home portion of my dose out into my car, and unscrewed the lid just to see if it looked right. (Take homes are mixed with water -about 50/50). It didn't look right- seemed too light a colour. I took the bottle back inside the pharmacy and asked the chemist if he'd mind measuring me a new dose, as I thought this one wasn't right."No worries", he said "I'm sure its right, but better safe than sorry". He measured a new dose out. I compared the bottles and realized the dose had been correct.

Note 1 : "Dr Dolophine" is a pseudo of a member, he is not a professional doctor.

"Sorry Greg", I said " It just didn't look right. Save the other one for me for tomorrow."

At no time was I put-down or made to feel embarrassed. This demonstrates the trust that can develop when MMT patients are treated as equals, as the same as any other customer purchasing necessary medication and on a level of one human to another.

There are of course down-sides to Australia's drugs policy in general. While harm minimisation is the cornerstone, there are still elements of the people with political power who consistently push for a Nancy R. styled "just say no" - zero tolerance drug policy. Thus a promising Heroin trial in Canberra -the nation's capital- was scrapped, and subsidies for treatment programs were withdrawn to fund a "war-on drugs" approach to combat increasing Heroin Use and Heroin related deaths.

[Update: The New South Wales state government have recently set up "safe injecting rooms" in Sydney as a trial. To date I have no information on progress]

---

**Dr Dolophine** [alhlee@netscape.net](mailto:alhlee@netscape.net)

From: Al Lee <[AlhLee@netscape.net](mailto:AlhLee@netscape.net)>

To: <[baudron@interpc.fr](mailto:baudron@interpc.fr)>

Sent: Tuesday, February 20, 2001 9:22 AM

Subject: Detox group?

Hi Izzy, I thought this may be of some interest to the detox group:

In response to an article I wrote for a U.S. methadone advocacy newsletter called Methadone Awareness which is now posted on the interzone site in the medical section under the title "report from Tasmania", I received the email included below. I have also included my reply.

the email:

" Dear Dr. Dolphine

I have just read your posting from 1998 and find it the biggest load of c\*\*p that I have read on the subject.

NO wonder you find the Tasmanian programme the best in Aus anyone would who was having 60mgs to dose and 60mgs to take home thats blockade 120mgs nobodys metabolism is that fast seeing methadone has a 36 hr after life I will put your idea to other doctors and see what they say and if they would be willing to split other clients doses I doubt it. I find that most people on that dose would find it very hard to get stoned on narcotics let alone spending hundreds of dollars trying, just to have their dose put up its BLOCKADE.

As for Terry the complaints are coming in thick and fast of being treated like second class citizens, being refused their dose if they don't have the money and being unable to change pharmists if they owe any money.

Keep your ear to the ground and talk to other clients.

P.S I am not on Methadone"

My Reply:

"Dear Louise,

Thank you for your letter.

I have merely related accurately and honestly my own personal experience. I have no doubt that there are many clients/patients in Australia and internationally who are treated shabbily. It was an instance of this in a clinic in the US, recorded in Methadone Awareness newsletter that prompted my letter to that publication - same letter which is posted.

I am very lucky to have such a satisfactory set up viz my pharmacist and doctor. Far from disagreeing with the complaints you mention, I whole-heartedly support the complainants and sincerely hope that our efforts and voices will be heard and heeded so that my own situation could be the very least that a person on Methadone could expect.

As far as my particular dose goes, that is a matter between myself and my doctor. It is included only as an example of the flexibility which I am fortunate enough to have been allowed and which is sadly missing from most programs. According to current pharmaceutical indexes, methadone taken orally lasts approximately 8 hours at the first dose and 18 - 24 for subsequent following doses, since it acts cumulatively. I have read and heard claims of 30-36 hours, but never from people who have first hand experience.

In conclusion, I can only stress again that I have only related my own personal experiences, and not with the motive of lauding the methadone maintenance program in general (and I do mean maintenance - as far as I am concerned methadone is contra-indicated for reduction purposes), but rather to point out the obvious disparity between what one can expect at best and the all too common and familiar poor treatment which so many endure.

Al Lee"

Please pass this on if you think it is of interest.

P.S. looks like were having a nationwide shortage of smack in Australia. The news reports it as well as users I know on Mainland Australia.

---

# Dreams

Isabelle Aubert-Baudron

## A simple method to get rid of nightmares

In 1981, Baud and I found a book by Patricia Garfield called "Creative Dreaming" (in French : "La Créativité Onirique : Du Rêve Ordinaire au Rêve Lucide", Ed. La table Ronde) which was about the teachings on dreams from different cultures (ancient Greece, American Indians, Senoï and Tibetans) and contained a method to get rid of nightmares. We both had some, and as the method was simple, we decided to try it.

It consists in writing down one's dreams on a little note-book beside the bed, so when one wakes up, one tries to get memories of the dream and writes some words just to remember it later. One has to have the desire to remember the dreams and, to get rid of the nightmare, say inwardly before sleeping : "I must face and defeat danger in dream."

The next day, one describes every dream with as many details as possible, gives it a title and index it with a number and the date. Then if the dream was not satisfying, we can study solutions we could have chosen in the context to modify it to our advantage, and decide that the next time, we shall choose another issue, and write it down as well. One has to remember that everything is permitted in dreams, and that we can decide of the events; for instance, in front of a danger, we can transform ourselves, like Merlin the Wizard, or call some friends for help, or realize that we are in dream and we do not want this scenario any more, etc. Then, one can follow the evolution of the recurrent nightmares, the theme of which often comes back, and see how we can change it from a dramatic issue to a comfortable one for us.

This is a summing up, as there are exercises in the book.

My nightmares changed the following way : at the beginning of trying the method and exercises, I stopped being the victim of violences, but became the aggressor, attacked the guys who were attacking me and killed them. They were not properly speaking nightmares, and stopping undergoing was great. But it was still quite violent and bloody, which was not satisfying. I had several dreams of this kind, until one day, I met an aggressor with a gun. I watched it, the gun became all soft, melted, and I burst out of laughing in front of him, and he found himself kind of stupid. Then I felt sympathy towards him, and felt he had done a good joke to me with his melting gun.. This was the end of the nightmares.

Baud had a similar evolution, but without passing through the aggressive step. His nightmares were merely about army : he was back into the barrack and realized he never left the army, which turned into a nightmare. One night he was in the barrack, in presence of the colonel, and took his military papers, tore them into pieces, threw them at the colonel's face and went away from the barrack. This was his turning point dream.

Sometimes after at the hospital, came a young patient who had nightmares every night : she had been raped some years before and every night was living it again in dreams . So she was very anxious to go to sleep and, awaking by night after a nightmare, she often tried to kill herself.

Baud told her about the method and she was interested. She read the book, got interested in her dreams and began to note them. Every day she was telling him about the new one and how she had managed then. First this changed her attitude towards dreams, because she had a way to act on

them, and did not feel powerless any more in front of them. After about one month, she dreamt she had met her rapist in the elevator of the hospital and gave him a monumental thrashing. This ended the series of the nightmares, and her problems with sleep. She went out sometimes after and never came back.

As a result we also found out that the change of behaviour in dreams had repercussions on our awoken life : instead of acting as victims, we changed our mental attitude and stopped seeing such situations as dramatic and hopeless to look for ways to get out of them. This did not change the facts by themselves, but made our situation much more comfortable psychologically, and helped in different circumstances to change their issues.

---

## Dreams (Interzone)

(We did an experiment on dreams, gathering them from July 1997 to May 2002)

Agent Izzy : Dream of November 28th 1981\_

" Baud and I are in the dining room of my grandmother's house, sitting at the table and writing. From time to time, I have the impression that some of the objects on the table, a colour pen, a pen, start to move slightly by themselves. That makes me abruptly raise the head and I stare at the pen which remains motionless. A bit later I am in a flat which has nothing in common with my grandmother's house, with a white wooden table along a wall; the walls also are white; there are utility and modern pieces of furniture, also white, and in the middle of the room, another table for drawing, perhaps with trestles; objects are laid out above: roller of Scotch, pencils, papers... Near the table, a modern chair, perhaps out of white wood. Over the first table, is spread out a black plastic sheet. I am in the middle of the room, the first table about one meter far from me on the left. I suddenly see the black plastic sheet which starts to move by itself, making like wavelets. Baud is in another room and I regret that he is not there to see that. I do not speak to him about it by fear of appearing ridiculous, or because I have the impression that he will not believe me.

We are then again in my grandmother's home with Gerard X (a patient in the hospital). We go to a bedroom with him; he will sleep there and we wish him good evening. Baud and I go to the large living room.

We are in front of the square table in the middle of the room, on which are laid out of papers, pencils and books. We are talking and everything is as usually when suddenly the orange pen starts to write a small text across the page of a book, then it stops, then starts writing again on the page of the book, mathematical formulas, sentences. The pen writes very quickly then stops. We come close to see what is written, I take the sheet and begin to look at it, quite astonished by the thing, when my navy-blue anorak raises from the back of the chair on which it was posed, as the shape of an invisible sphere lifts it up. There we start to be afraid and I ask the invisible entity who he is and why he chooses to do that with us.

Later we walk in the street of an old city, may be Poitiers. The invisible entity remains with we and we can communicate with him through thoughts without nobody knowing it. He gives us his opinion about events and people that we meet and we are aware of about all that really occurs. The entity is well because we hold company to him.

Since a few days I have noticed around us like cobwebs with kind of insects which look like roasted chicken with legs of grasshoppers. At the top of the legs there is a large round and black eye. These small beasts are everywhere, even in the closing of my satchel and I think that I shall have to remove them. At the same time I see a big one on a wall and am on the point to crush it when the invisible entity says to me: " This animal is part of me; if you crush it, you remove something in me and you destroy me at the same time . So I decide not to crush them anymore.

They are wrapped in cocoons made in cobwebs and do not move. They have an anxious glance as if they were scared that I remove them. They only want to remain there and to have company."

The apartment with the white wood pieces of furniture was well that of Brion Gysin. Same laying out of the place, same atmosphere, similarity of the pieces of furniture and of many details.

---

My Dream July 26, 1997 Nicholas Knutsen :

The first thing I remember in the dream is that I'm in a complex of corridors leading downwards. The walls are white, and the place is like the stairwell in a public building, only bigger, with more choices of openings and staircases. I'm there with a lot of people, and I know some of them, like on

some sort of convention. We're all going down, turning corners and walking down the stairs. Sometimes I stop and talk to people that I know. Now that I'm awake I can't remember who they were, but I know they were both friends I have now and people I used to know. There's a feeling that we're going somewhere. There are people all over the place, and I don't know how far down some of them have come or how high up some of them still are.

Gradually it becomes clear that we have a time limit to get to our goal. Then we're there. We come down a staircase, and we're in a room that's a little bigger than the "rooms" between the staircases. There are still some more corridors leading out of this room, but they don't seem to be leading further downwards, only straight ahead. But we know where we're all supposed to go. The wall at the other end of the room isn't there. Instead it's an opening leading in and slightly down to another room, or rather a biggish corridor. The structure of the rooms is a little unclear, but there are some glass walls probably on either side of the opening, so that we will go between the glass walls.

Everybody now has a sense of danger about going through the opening, because we know that there's some sort of field there between the glass doors, so that one can't just step through, but rather something will happen to you. But the time limit is still there, and time's running out. I throw a plastic bag which I had with me, through the opening, and it bursts into flames in the air as it crosses over. Then somebody tests just waving a bag through the opening and back without letting go. Nothing happens to the bag. Somebody says to me that probably only loose objects, which nobody holds on to, will be destroyed. I want to find out more, but there's very little time left. I go back to the other side of the room, and in one corner there's a bend in the room, and behind that corner is some sort of information console. I find out just how much time is left, and it's just a few seconds. I also realise what will happen too anyone still in the room when the time is out. The room will be filled with blood. A big wave of blood, just like in "The Shining". Those left will drown. The dream now turns into a nightmare.

I want to find out more, even though I can't technically make it on time. Still I have this notion that the reality of life is such that always when one thinks one is running out of time, there is always a little time left. So I stay by the console a little too long. I run out from behind the corner, and realise that everybody's gone. They have all stepped through the opening, and the room is completely deserted. I now notice that the room on the other side leads around a corner, and further ahead to some other place. The room doesn't look clean or clinical at all, but pretty realistic, more so than the corridors I came from. There's dust on the floor. It seems that there is seeping in some daylight from behind the corner.

I'm running towards the opening but it's already closing, with a glass door where there was only an opening earlier. There's no way I can make it. And I don't. The door closes, and in panic I turn around. I want to run out the way I came, but can't quite remember the right way. I run into one of the hallways on the side, but as I turn the corner and look down the long corridor, I see the flood of blood crashing towards me. I realise that it was true. I run back and up the stairs as fast as I can. I come to the level above where I was, find the stairs and start up those too. But it's too late. The blood is already spurting up from the previous room, and filling up this one. I'm being pushed to the ceiling, and I'm certain I will die. But miraculously I find the opening where the staircase goes, and the stream of the blood pushes me hard further upwards. In each room I find the opening, although a couple of times I have difficulty getting to them. Then I hit the surface of the blood, and run further up, away from the tide of blood. I can still hear it gushing behind me.

Then I reach the top, and I climb out on some sort of roof top, but it's small and more like a knoll of grass. The feeling of safety is short. Suddenly I have a feeling that the nearing blood represents danger, even though it's not completely clear how it will harm me here out in the open. I ask myself whether the blood will actually come all the way up here, and I decide I have to get as far away as possible. The place seems pretty far up, but there's plenty of places to go. It's like a mixture of roof

tops and grassy hills. I run ahead and a little bit down, and I come to a vast asphalt lot. I have a weird thought about all the people who disappeared through the opening without me seeing them. Then suddenly evil people are approaching all around me. They seem to be like zombies, and they're all out to get me. It's like the danger has caught up with me.

I then have a feeling which I sometimes get in dreams, to various degrees. I feel like I can maybe control the situation, or at least that I have a chance of making it. Beside me there's a trash can half my height. I place it in front of me, and step into it. Then I fold out a pole from the side of the bin, which then points up into the air. I proceed to fold out a crude propeller from the pole. The propeller does not even reach over my head. The blades, which are more like rulers, are all wrong, because they are flat vertically, thereby making it technically impossible to make the trash can fly. In the dream though, I just think that this faulty propeller will make it very difficult to fly. The propeller starts spinning slowly, then a little faster, and I take off. The zombies are directly below me, and I feel like I'm getting away. But I only get a few feet off the ground, and they can almost reach me. Some of the propeller blades start folding halfway back, and the propeller stops and starts. It's evident that it's not the air pressure created by this puny propeller which is causing the can to levitate, but rather the very spinning of the propeller itself. I have to keep folding up the blades, and even spin the propeller manually with my hand. I almost touch the ground again. Now I've gotten a little way away from the zombies, and I'm almost off the lot. Still I can't make the can really lift off properly, and I realise I won't get away like this.

I come to a grassy spot, and there's a cliff, and I look down over the edge. It's a straight drop hundreds of miles down. I become very happy, because now I'm convinced I can make the can fly. All I needed was to start from very high up. I throw myself off the cliff, but now it has changed. It's not a straight drop any more, but rather endless dunes of grass in levels diagonally down and forward. I glide a little in the air and then I hit a dune. I glide some more and hit another. Then I get to a somewhat steep dune, and I glide a long way forward. It almost feel like I'm getting away.

Here the dream changes. One could say it becomes a totally different dream. But as you will read in the end of this dream, I remember back to the first part which I have now described to you.

I remember very little from the beginning of this dream. This dream is not a nightmare like the last one, but it becomes pretty unpleasant towards the end. It consists of two very different elements. Firstly, I'm involved in some kind of science fiction-like project, having to do with alternate realities. Secondly, one of my grandparents' grandchildren dies. These elements are somehow interwoven.

I don't remember exactly how I find out about the death of this grandchild, but I remember that I have never heard of him or her. In reality, my two grandparents on my mother's side (I have no contact with any relatives on my father's side) have only three grandchildren, myself and my male cousin and female cousin. In this dream, there is, or have been, another. In real life, I have a lot of contact with my grandmother and my grandfather. I remember they are very sad about the loss of their grandchild.

The "sci-fi" part of the dream is extremely weird. First I must explain something, a feeling that permeate the whole latter part of this dream. It is a feeling of everything being iconographic. Nothing really happens realistically, but rather a representation of an event occurs. So that, when I am with some sort of scientist and he's showing me something in his telescope relating to this project, I don't see stars or planets in the night sky. I see small white numbers with periods after them. I think it's the number "6." we zoom in on. It is shining white, as if it's a hole punched in the sky. The shape of the digit is not smooth, just like when one looks up close at letters in a newspaper. We keep zooming in, and when we get really close, the whole "6." seems to evaporate, and reveal a huge group of planets. It's like the planets were hiding "behind" the number, but it's like both the scientist and I know that the number had only \*represented\* the planets.



We zoom in on the planets, and then I recognise the pattern on them. The continents on the planets are all exactly the same. They are all Earth. I realise that they all must be alternate realities of the planet Earth. This means that all the possible alternate realities of Earth do not exist in different timelines, but on different Earths floating in space next to each other.

The next part of the dream I remember, starts out with the project, but melts into something that I'm not sure what is. I'm with two scientists and they're looking in some sort of laptop computer, only there's no top. The LCD-display is on the machine itself. They have apparently been using this device throughout the dream, to monitor some sort of activity. But there's nothing in the display. I say to them something like, "Come on guys, make it look like you're watching something there." The feeling is again that we all know that this "machine" is only a representation of a machine that they're looking at. This relates to the fact that this is all a dream, (although I don't realise this in the dream) so it's actually true that things only \*represent\* real things in the dream.

The scientists sort of "will" the machine to change, and a grid appears in the LCD-display. I'm still not satisfied: "Come on. Show what you're really looking at." They kind of say, "Oh, okay," and the display then shows the continent of the USA. I say something like, "That's not right. You have to zoom in on where it really is." They start panning and zooming the view in the machine, but suddenly it's way too close.

Now the view is realistic like a real camera or binoculars, not an LCD-display. In the machine we're looking at a woman's bust. She's wearing a sweater, but we can see that there are breasts behind it. We all act very macho and boyish, and although we know that it's not what we were supposed to find, we sort of say, "Yeah! Leave it there! We must watch this!" Then the dream blends over into me actually being there in front of the woman. She is sitting leaned up against a low stone wall, maybe two feet tall. There is grass on the ground. To her right there is another woman, which I seem to remember to be blond, whereas the first woman is brunette. (This is not significant, I think. But then again, I have no idea what is significant in this dream, so I'm including as much as I can remember.) To the women's right, and my left, there's a middle-aged, jolly-looking man, with sideburns. In the dream I know him, and I relate to him as I did to the two scientists. The two women never say anything, and are more like puppets than humans, but it's nevertheless clear that they are alive. They have a blank expression on their faces, and look straight ahead. In the dream I'm not bothered by this at all.

I spot a cable with a plug at the end, lying in the grass to the left of the man. I pick it up, and I know that it's connected to the brunette woman. Sort of like a joke, I say something to the man, and put my hand over the ends of both poles of the plug, thereby "jamming" it. I sort of knew what would happen when I did this. Two powerful jets of water, or some other liquid, squirts out from her breasts and through her sweater. The man and I both laugh. It's like a cartoon gag when somebody jams one end of a hose so that water squirts out somewhere else. I say that I have to go, and I get up from the ground and walk across the lawn so that I can't see the three people on the other side of the stone wall. But the cable is long and I carry the plug with me part of the way. As I walk away I still talk to and joke with the man. I "jam" the plug in different ways, and I can control what happens on the other side of the wall. First I make the woman squirt water beams down in the ground so that she's lifted several feet high up in the air, carried by the water jetting from her breasts. I land her, and then I make the water jets carry the other woman up in the air. All the time I say comments to the man, and we both think it's funny. The women are showing no voluntary motions. Finally it's the man's turn to appear over the stone wall, as I make him ride on top of the water fountains. He also has a great time doing this.

The lawn where the stone wall is, and where I have been walking, is the lawn outside the house where my aunt and uncle lives (in real life also, although the stonewall is not there in real life). My aunt is my mother's sister, and her two children are my two cousins. I arrive in the house, and the

whole family is gathered. I remember my grandparents, my aunt and uncle, and also my mother. (In reality, my mother hasn't been in that house for nearly ten years, due to the fact that my mother and my aunt and uncle are not friends after an incident that happened at that time.) My uncle says to me that my grandfather has baked a chocolate cake that I should taste. This is something he does regularly, (in reality he never does this, although he does make waffles all the time) but now, after he learned about his grandchild's death, he could barely go through with it. Still, he managed to finish the cake. I say something about the cake not really being cake, since it's all just \*supposed to\* be stuff; but ask to be given some cake. I am served a piece of cake, and eat it.

I'm sitting to the right of my grandmother, who seems really sad. On the opposite side of the table my mother is sitting. This is where she always used to sit. My grandmother, who is hard of hearing and also not very intelligent (also in reality), says something. I can't remember exactly what, but it's something trivial; perhaps, "This cake is really good." I'm wondering if she really meant it, or if she was being ironic. In real life I would never wonder this; neither of my grandparents have ever been ironic as far as I can remember. I say, "Grandma, did you really mean that, or were you being ironic?" She says, "What?" I rephrase the question: "Were you being serious, or were you kidding?" She still says, "What?" I'm not sure if she doesn't hear me, or if she doesn't understand what I mean. After several rephrasings, and putting it in the simplest possible way, I almost give up. She should understand what I mean, she's not \*that\* stupid. But my mother's convinced she does hear me, she's just too stupid to understand. She starts yelling at my grandmother, and saying really cruel things to her, crueller than we would ever say to her in real life. I'm appalled at my mother's behaviour, and I say something to her about it, but it doesn't help. When she stops, I feel really bad for my grandmother.

I turn halfway round with my body, and I'm looking out the window behind the couch where we're sitting. Suddenly I'm overcome with sadness for the dead grandchild. The grandchild is like me or my cousins, with the same grandparents, and in the same generation and the same family. I cannot remember him or her, but I remember thinking that I feel like someone who did know the grandchild, or like someone who knew the grandchild, must feel like. I also feel terrible thinking about how my grandmother must feel, with the dead grandchild and my mother's abuse. Not being able to stand it any more, I give her a big hug and start crying. I'm thinking that I'm feeling embarrassed by crying like a child in front of the whole family, but I don't care about that any more. I say to my grandmother that I'm sorry, that I'm sorry about everything, and I start to list all the things that I'm sorry about. The list includes things that I've done from the beginning of the dream in the stairwell, and up to this instant. I can't remember any concrete things that I say; but the feeling when I was saying them, was that some of them were from the very beginning of the dream. I hulk loudly as my grandmother and I embrace, and it's a feeling of great release.

I see a member of the family who is not defined, who is sitting to the left of my grandmother, and I swear I can see the person's eyes being wet with sorrow, as if taken by the display of emotion exhibited by myself. The dream ends here.

---

Yana Ya Ya : August 13th 1997 :



This picture arrived in my attachments file on my computer, mysteriously 2 days before Wm.B was gone again. On Sat. night/ Sun. morning (the night he passed) I had a dream that I was giving my father CPR because he was dying from a heart attack. I couldn't save him. I questioned several of my friends 2 days before Wm.B passed away if they sent me that picture. There was no email attached and no one has confessed to sending it to me. Kinda strange, huh?!

---

Rick Gentry : 9 9 97 :

Several people are gathered round talking outside of your house in France and then the leader of the group, who appears to be Baud, says to follow him. We begin walking forward and instantly we're in a vertical tunnel leading up into the sky walking with our backs against the tunnel and perhaps upside down. I thought this was very strange yet entirely normal and really a great way to travel that I had heretofore been unaware of. It became apparent that this was along the lines of Don Juan/ Don Genaro teaching stuff. You were there though I never saw you and so was Gary, or at least it "felt" like Gary.

Shift to your living-room, several people sitting round, maybe smoking pot. I could feel the French countryside outdoors. Baud is the leader of the group, is mid-20's, tall and slim with long, straight, dark brown hair.

I looked over to you to see what you looked like and saw that your hair was brunette and in curls and about shoulder-length and remembered that you said your hair was red and you were often mistaken for a boy and thought how you didn't appear as described. I then looked closer and noticed your skin was dusky, olive-complected and glowing as if dusted with a fine, white powder. I thought you were very beautiful and saw that you were maybe 22 or 23 years old at best, definitely did not have red hair, and fade out...

---

Isabelle Baudron : August 11th 1998 : the layer of blue air :

"It is in the morning, Baud's parents are coming for lunch. They park the car on the parking in front of the house and I come to welcome them. At this moment I watch the sky, there are yellow clouds, but I can see the sun through them anyway. It is over the big pine-tree, smaller and a bit paler than as usual.

Then I see a layer of blue gaz, blue-octopus, 1 meter over the earth, about 50 centimeters thick. It is everywhere, in the path, in the garden, through the trees. Baud's mother says: "We saw this on the road when we came, it is everywhere, since N". (the city they live in). I do not say anything, but I know we (all the people of Burroughs' experiment) are making this and that it is related to the message of the girl who wanted to make an experiment of communication through thinking at a precise day at a precise hour.

---

Isabelle Baudron : August 15<sup>th</sup> 97 : the big hotel : Gary Leeming's room

I'm coming in the huge hotel, as vast as in the previous dreams. There are many floors and buildings. In a corridor, I'm looking for a room, and I'm afraid of something without knowing what exactly. I'm hearing people coming and open the first door on my right, put my pack-sack in the room the door of which in front of me is opened and which looks empty to me. Another room is on the right, the door is closed. Closing the entrance door from the inside of the flat I see written on it "Gary Leeming".

---

Orin Holland : September 6<sup>th</sup> 97 :

i'm reading the wild boys right now, and my dream last night made me think of it. my family was planning a move back up onto some property that we own and lived at when i was very young. we met neighbours up there and started talking with one of the girls with short, dark hair and who spoke in broken English. she revealed plans of theirs to start their own country, and i mentioned that we would not interfere. from this comment she took us into confidence and started talking more and more, at one point revealing she gave a lethal injection to someone who would not accept part of the "mind-rubbing process". with this it all became clear. they were some kind of cult, and this girl and a man nearby were in charge, everyone else, who had shaved heads sunken eyes and looked a bit like walking skeletons, were their underlings. waves of evil shivered through my body, and i was unsure what to do...

---

Alex : September 27 1997 :

-I am walking down a wooded lane; I keep losing my teeth with my tongue I feel them loosening and then separate;

I spit them out watching the blood and feeling the holes once again with my tongue..

-I stop at the end of a bridge looking at a downed tree, it has been cut and has fallen into the ravine, there is a round fish-bowl on the bridge railing containing money bills and grass clippings and leaves

- majestic palace full of corridors, repeating image of princess (?) climbing through trap doors and always ending up in identical spare room, covered with mirrors reflecting the image...

---

Baud : rêve 3732 V. 071197 : 1h-10h30 : Hotel Interzone

Was this old limousine from the fifties, with its incredible wings, following us ? The city was American. New built houses, long straight streets, gardens without fences. I was at the back of another old car, the eyes lost in the landscape. I forgot our followers, and we went to the hotel with a round wooden stoop, painted in blue. Burroughs was in the hotel, a vast room at the first floor with sash windows. He had settled there for sometimes, and I did not come at random until this lost place. The hotel inside was a bit tired too : old dusty carpets. I climbed nearly directly up this bedroom. The other rooms were reserved for a whole group of guys who were his guardian angels, were taking care of him not missing anything, filtering the visits, etc. I put my 2 leather suit-cases on a thick carpet with strange drawings which was covering the floor of his bedroom. The bed, a king size one, was in the middle. The most astonishing was this huge pillow, as big as the one of the Kaliph Iznogoud (French comic). Bill, sunburnt, was lying on the bed in the room. He invited me to come closer, and without saying anything, showed me a tiny TV set stuck in the left angle of the bed. It was playing a film on the carpet which had just been offered to him, a carpet which was changing according to the lightning after the fall of the night, though the eye could not perceive the different lightnings. There was a visible system at the ceiling with little spots. There also was a kind of a screen where cut-ups were streaming. The carpet was changing on a marvellous way. I was fascinated by those gadgets, knelt down in the angle of the wall. I felt Bill's had stroking my hair. I was surprised, did not try to move back. He did it again when I sat on the bed. I was seeing his hand with the cut finger. He was looking fine, and did not insist. Very relaxed, he laid himself down, as if he was gonna sleep. Two other guys came and lay down besides him in the bed. Another guy signalled to me to follow him. I got up, leaving my suit-cases in the room on the famous carpet, still inanimated, while the two blond haired guys were smiling under the white sheets up to their neck. We passed the door...

Jill: Dream October 8<sup>th</sup> 1997

Odd thing happened two nights ago. I dreamt I was driving a car to a place where I was to collect a "dream machine". Suddenly the car went out of my control, but not in a dangerous way. I could just feel that I had no control over it. The car proceeded to drive itself very fast and powerfully to this place where a woman was waiting for me at a table outside a café. She was none I knew or had ever seen but her appearance was very clear to me. She had shoulder length red blond hair, rosy cheeks, slightly freckled face, medium build, maybe more tall than small as much as you could tell from sitting position. Then I woke up but I had a most unusually clear memory of the dream.

---

Foe Tamajiro : October 8 th

The castle in my dream was more like an armed city, surrounded by vortex of steam from boiler rooms? the steam surrounds the city like the mist. It reminded me of the flying city in a Swift novel, what was that called,.... Laputa. But it was located across a bay, or a huge delta, the mouth of the river. And the dream begun as a book this lady started reading, while having early supper at the porch of a restaurant/bookstore. It was supposedly her favourite restaurant, and it was Foe's first date. Foe met her at New Orleans Hotel and Casinos, which is a real hotel, which is located down the street from where Foe's PC resides, Higashi's resident, on W.Tropicana Ave., Clark county, NV, U.S.A.. The lady was a some sort of accountant, her office was located at the end of this labyrinth like hallway. She reads me a book about the steamed city in the dusk. The next shot cut into an interior scene of the tower. Outside in, Usual logic of dream. Foe, standing by a window, sees the wall of steam FROM INSIDE. foe also has a bird's eye view of a medieval city. The wall of the steam is so thick. the view of outside world is concealed from the towners.....

---

De : Gary Leeming : mardi 18 novembre 1997 20:37

Different house, in a dream town made up of imaginary bits of lots of Northern towns. Izzy turns up unexpectedly, though she had apparently warned us that she was coming (it is morning) and then Rick/Andy arrives (I'm not sure who, quite tall, prematurely balding with the boyish looks that often go with it) The house is a mess as always. I have the fear even before you arrive. Rick/Andy sees a copy of the Karika on the floor and picks it up. I explain that it's really good, important.

I have to go out for something like milk. In the street I run into an old friend of mine called Anthony, a hippy. I say hi and remember I need some blow cos there's no way either of you two can have brought any. As I'm talking I see a shooting star and think maybe I should tell Ant but reckon it'll be gone before he turns round. But it just keeps growing, first into a comet and then a ball of fire. It lands nearby so we go to check it out. It's landed in a big park on top of a hill. A black church is visible. It seems to have taken out part of an old concrete building but the building is in good shape - They don't make them like they used to. Lots of kids are about scavenging, getting bits of rock for themselves. Someone mentions insects arriving from outer space and I inwardly smile. I pick up a scrap and examine it but it seems like it's just concrete. I look more closely and see that bits of the rock have become fused inside it. There is a bigger block of meteorite about a hundred yards away, landed in grass. I figure I'll check it out and get a better bit of rock. Ant has become Rick/Andy. There are men standing around this site, which is flat and has a molten appearance and kind of quartz like. The men are scientists moaning about people coming and nicking their rock. One of them is standing slightly apart and is in better humour about the whole thing. This lump is purer than the other but all solid. There is a loose piece shaped like a thick scalpel which I pick up. The good humoured scientist nods at me as if saying I can take it but another scowls and asks for it back. He puts it in a black plastic sheath and uses it to score the block as if cutting it up.

I decide to sack it and go home, empty-handed. Andy/Rickstays behind for a while but when he comes back he has the scalpel rock and gives it to me with a grin. I'm grateful and happy and sit there examining it. I decide we need some music and go upstairs to look through my records. Izzy comes with me looking at them over my shoulder. I pull one out (Time Boom/De Devil Dead by Lee Perry/Dub Syndicate) and Izzy thinks it's the one I've chosen. It wasn't what I had in mind but I figure I haven't heard it in a long time and it's a good album so we go back downstairs with it.

---

De : [Foe Tamajiro](#) : mercredi 19 novembre 1997 04:09

I have been having dreams too, especially ever since I quit smoking for the god knows how many time...I found myself so many times in a multi-layered structure which is bleak and a sort of minimalistic, extended structure of corridors and hallways, the whole atmosphere reminded me of those 3D-search and destroy games such as Doom and Quake, but the impression of it was very decadently romantic, nostalgic, surrealistic, Science Fictional, right up your face, intimate, platonic.....My family was there, the one I am trying to be a part in its creation, and all sorts of loves, affections, most of them from the past, quite a few of them, from somewhere unknown, future?. anyhow much of love and respect, and look forward to seeing your text published on the net.

Tamajiro

---

De : [Rick Gentry](#):mardi 25 novembre 1997 06:30

Dream Sunday of William, I am his caretaker, I am wandering through his flat and realize he is dead, ask myself is this a dream, decide no, it's not, I know this room well, I actually was his caretaker, then no, this must be a dream, I am dreaming of dreaming of being William's caretaker, and I've dreamt this or been in this room many, many times....

Scene shifts to Isabelle appearing at my door and I am annoyed, even angry because she shows up unannounced. Soon everything is okay, we talk, meet with other friends and play games together. Scene fades with me looking intently at her hair and profile, hair is brown, wavy and shoulder length, dusky complexion and skin slightly aglow like a moon is inside her skin...

---

[Baud](#) : Rêve 3740 Me 261197 : 1h30 - 10h15 - William and Brion Gysin in R.

Burroughs and Gysin were in the house, which was very different from the real one, with elements taken from here and there, as if the distans-doors were a reality, real from were communicating with unknown other ones. Burroughs was exploring the ones after the others the different parts of the space he was about to spend the evening in. He had kept his Stetson and black coat which made him look stronger than he was. More disturbing too. He appeared nervous, as a nervous agent who explores a place for the first time before settling there to spend the night. I was making all I could to make him comfortable. I showed him the library the parts reserved to the Beat generation where his writings had a large room. Then we went to a dining-room with old furniture, kind of middle-class style. On the top of a wardrobe was a huge book which weighted at least 30 kilos, with a golden edge, a vestige from middle age in perfect condition which I wanted to show him but that for the moment I was not able to join. I needed the footstep which was at the bottom of the garden. A door was leading to a old hall. We crossed to join the sitting-room where Brion was sat on the sofa. I thought he was suffering and I bent towards him to propose him a pain-killer. But seeing he was okay, I proposed a cognac or a coffee-liquor which lit in his eyes a light of malice.

[I. Baudron](#) : November 27<sup>th</sup> 1997

I am coming at the Academy, a huge building, quite old and complicated with several parts of buildings. I begin to visit it, walking into a long corridor. On the right, there is a square garden which looks like a cloister of an abbey. At the end of a corridor is a door. I open it and arrive in Andrew's bedroom. In the left angle of the room is a mattress put on the floor and covered with a dark blue bedspread. Andrew is sat on it cross-legged, dressed like on the picture he sent. We look at one another. He must be writing. The walls are covered with book shelves and along the walls there are tables on which equipment for drawing and writing. The floor is covered with a carpet. I cross the room to another door on the right, open it and go on the visit.

Then I am coming in front of a house in a street, close to the abbey. I open the entrance door and come into a corridor at the end of which is another door with a glass window which leads to a garden. Three other people arrive from the street : a guy who is about 45 y.o., with mat complexion and shaved skull, dressed in leather . We shake hand. Then a couple : a girl with long fair hair and a darkhaired guy who looks like Fred. They are French and we worked together in the seventies. We are going to talk to a sitting-room, Indian cushions, comfortable furniture rich hippy style. We smoke in talking. At one moment, the girl takes a grey and white Moroccan ashtray in clay and drops the top which falls on the ground and breaks.

---

[Agent Zero](#) :jeudi 27 novembre 1997 08:08

nice dream,

i once had a dream where i was transported to this beautiful academy of advanced beings,scenery looked kind of like Greek architecture, i was walking around checking out the various teachings going on. There was a great crowd of people on the steps of the building and somebody yelled "the wind , the wind , and everyone started running, not out of fear but with joy suddenly I found they had all transformed into flowers and i was alone running through the field of flowers, it was very powerful.

---

De : [Agent Zero](#) : jeudi 11 décembre 1997 19:14

I had one mildly sexual dream about Burroughs after his death. I met him in a parking lot sitting at a small book signing table. I wanted to show him sketchbooks, and i did , he liked them, little emotion though. We started kissing, French kissing.

wow izzie / now i realize the French kissing may have been a sign of our meeting in the future,as this dream happened before the group formed.

---

De : [R. Gentry](#) : samedi 13 décembre 1997 07:32

Dramatis Personae:

B.J.: Landscape Architect at a resort hotel and restaurant I used to work at.

Sherril: B.J.'s daughter and General Manager of the hotel.

Laureese: Hotel Employee.

Fade in; wide awake dreaming... BJ is running across the hotel trying to give me something. It is a \$10.00 bill. I explain that she doesn't have to tip me that much, "really, it's not necessary." Shift to Sherril, me saying "tell your mother she needn't do this. " Sherril is slightly embarrassed, doesn't want to get involved. Fade out.

Next morning: Lunchtime. Taking Laureese's order for food at table 26, hear BJ's voice behind me. Look across the room, she's standing, trying to get my attention, waving a \$10.00 bill in the air...

---

De : burroughs william: lundi 15 décembre 1997 23:20

I have a dream last night, c'était dans une ville grise et délabrée, l'idée principale était de combattre un virus, sous la forme d'un pigeon, (je ne sais plus bien).

---

---

Jill : December 18 the 1997:

I have dreamt of giving birth to fingernail size babies, which after much struggle and grief I couldnot keep alive. Then later I dream that my dear departed father is trying to kill me in some Abraham and Isaac sacrifice scenario while meanwhile my mother is plotting to maybe rescue me, before this happy outcome I awoke, somewhat mystified as who wouldn't be.

---

Jill : January 9<sup>th</sup> 1998

This is so familiar, it is like a recurrent dream, recognised like something that really happened. I am a young student at university and two men keep following me about claiming to know me, but in my dream I know it is a pretence and they want to take me over, take control of me in some non specific way, though they are pretending they want to protect me from something, also non specific. One of them grabs at me and some little folded rectangles of paper fall to the ground. "Look" he says "you know what these are, someone is trying to set you up. You know what trouble you can get into etc." One keeps calling me Rosemary (the name of an old school friend), who I swear I am not, he produces taxi receipts, lists of names, phone numbers to prove to people gathering about that he knows me, has some right to be after me. Then I run and run and get caught up at the counter of the sports faculty, they pursue me and now they are naked and one of them says to the man at the desk "Look we've seen her with nicotine" and the man looks disapproving and I'm afraid he will not help me after all but then he says "Well, what of it, that's legal isn't it?" They are hustled away but now I am afraid of other things they may bring up and I am sure I haven't seen the last of them. This time there were two of them, before it was only one, a most repellent, reptilian, sleazy guy.

10th January's :

I am travelling through Palestine and I get a job as an artist, doing drawings of the different views and stages of a temple that is being built by Jesus Christ and followers. Then I am doing a sketch of the men Pontius Pilate has sent to burn down and destroy the building just as it is almost finished. I am drawing the altercation going on in the front of it..Scared followers of JC hang about, looking a bit like they wish they were elsewhere. One actually does sneak off round the back. Then Pilate arrives and the temple is completely wrecked. PP then goes off to a building shed nearby and rolls his gear out on the workbench and proceeds to sketch out a picture of the event that has just occurred. Rather like the big charcoal cartoon old painters would do for a fresco. I ask him if my drawings are still about since I want to do more on the one I was up to when he interrupted us. "Sure, it'll be about" he says. "We wouldn't burn that. Do you want to use the other end of my table?" "Oh no" I say. "I don't think you'd want to see me doing that". "Spose not" he says. I go out, find the crumpled drawing I'd been doing and spread it out on a workbench next to the wreckage of the temple and start again to draw the scene where they burn it. PP comes over and says "Am I going to be in it?" "You don't want to be, do you?" I say. "Spose not" he says. "I didn't think you would so I didn't put you in it" says I (showing remarkable capacity for self preservation) I start drawing JC's face. Strong hooked nose, wide mouth, dark complexion. I plan to put a hammer in his hand, a tool bag round his waist over the traditional Arab costume. I wake up and wonder hat the



hell was all that about and do I really want to know, which I suspect says something in itself. Actually I think its got the feeling of a country and western song, like off Bob Dylans John Wesley Harding.

11th January :

I dream I am watering plants growing in my room, splashing water all over a wide floor that hardly leaves a puddle. Great big fuchsias and rhododendrons grow out through the top of the hydroponic box, burst out and drop their big blooms on the floor. I wake getting ready to get up and collect the flowers that have been washed under the table by the those.

15th January :

I dream that an apricot tree in my yard which has already finished its fruit has a new crop on it. Not a lot, just another bag. Enough of dreams, here is a bit of being awake which might say something to someone, also reminds me of a country blues song which might start Standing on the platform, waiting for the train. Scumbag rat come up to me I didn't know his name.....etc.. anyway, a little while ago I remember I mentioned I'd had cancer and I had chemio treatment and all my hair came out. Looked pretty cool I thought and eventually I'll send a picture. Not everyone shares my taste though and 3 or 4 times a week when I go to the chemist to get the methodone I kept running into this nasty young man who definitely didn't. Started like this; I'm standing waiting at the counter for the chemist to bring the dose and I hear this guy whispering loudly to the girl he's with "I hate smart women, hate a smart bitch with a mouth, I'd like to fix her ugly head". Well I dont expect every one to love me, and some people it would be a real worry, so I hopped on my bike and went off since I had the good luck to be in front of them in the line. Soon afterwards my bike broke down and I had to take a bus. Who do you think got on behind me? No prizes, sorry. "Not you again" he muttered as he dragged his girl past me down to the back of the bus where he maintained a running commentary till we got to the chemist about bald lesbian bitches who think they're tough and think they're smart and how he'd show them, whatever. Bus pulls up at chemist, he grabs girl and races her over the road to make sure they get in first. In the shop on he goes again muttering away about his hatred of women who have no hair and how he'd like to get them round the back and bash their faces in. The girl was looking a bit embarrassed by now, but not much but I didn't wonder much why she needed to be given antidepressants as well as methadone. Our paths continued to cross more or less in this amiable manner and I never said a word though I was starting to ruin my peace of mind with some pretty poisonous fantasies. The last time I saw them I was waiting with my bike on the train platform to come home one Sunday when the bus wasn't running much and they turned up. This time the girl came and sat down the other end of the platfrom while he raged and staggered about, very drunk, on the ramp down to the platfrom, yelling abuse at me, and by implication all bald people, homosexuals(and actually I'm a behaviourally hetero mother of one teenage boy, who is sometimes embarrassed by my appearance but probably would be anyway, but draws the line at getting vicious about it) and anyone who might be suspected of being smarter than him. I don't suppose this inspirational little tale will do much for the local tourist industry but then I don't work for it. Really this is not a typical event from daily life here but it's the sort of thing that makes an impression, and the world should be warned, the battle against ignorance, prejudice etc. hasn't been won yet. Eternal vigilance and may the zone continue to protect its own.

Another thing about dreams. Personally I've had countless of the labyrinthine, tunnels, canals, buildings, the endless search through them, the comings and goings of those you know and don't. Sometimes I feel that the roof of these worlds is the inside of my skull, some of the journeys feel like within a symbolic body. But, yeah, lots of dreams by the sea, tall buildings, old 18th19th century standing on wide promenades by the sea, the light always of twilight or dawn. Sometimes dangerous journeys to remote rooms where there is someone who must be seen.

Foe Tamajiro - January 26th 1998 :

Dreams, it has been so long since I stopped recalling any. Your picture of the castle and Baud reminded me of one of last dreams I had at the beginning of December. the castle in my dream was more like an armed city, surrounded by vortex of steam from boiler rooms? the steam surrounds the city like the mist. It reminded me of the flying city in a Swift novel, what was that called,....Laputa. But it was located across a bay, or a huge delta, the mouth of the river. And the dream begun as a book this lady started reading, while having early supper at the porch of a restaurant/bookstore. It was supposedly her favourite restaurant, and it was Foe's first date. Foe met her at New Orleans Hotel and Casinos, which is a real hotel, which is located down the street from where Foe's PC resides at X. The lady was a some sort of accountant, her office was located at the end of this labyrinth like hallway. She reads me a book about the steamed city in the dusk. The next shot cut into an interior scene of the tower. Outside in, Usual logic of dream. Foe, standing by a window, sees the wall of steam FROM INSIDE. foe also has a bird's eye view of a medieval city. The wall of the steam is so thick. the view of outside world is concealed from the towners.

---

Foe Tamajiro - January 28<sup>th</sup> 1998 :

Dream1: Los Angeles looks like Tokyo, lots of Japanese style houses filling up the valley. I found myself right by an airport. There was a small park, where a Hispanic teenage girl squat down, and urinating with her sensual bare ass exposed directly at me.

Dream2: Tibet, sand dunes, I make love to a native woman in the sand, literally underneath the layers of the sand.

---

Littlemute :Feet : Jan. 28 th 1998

Most pilots were instantly addicted arms and legs withering some acquired supernatural talents giant brain pans...make enemies nose bleed for fifteen to twenty days...acid for blood...rearranged face...appear as a man or woman...corrupting presence...extremities become sharp as bone cut through skin...implants...back of head shaved stitches insect legs white flaky skin...bone dust. The problem with pre-modern attempts to utilize, especially by the light summer breeze and hung about in the event of over had a[r]mour rose.

Greetings, large black person. Let us not forget to form a team up together and go into the country to inflict the pain of our karate feet on some ass of the scum.

I am sure you will not mind that I remove your manhoods and leave them out on the floor and hung his legs among hers to open, rubbed her breast and crotch by his foot and wrinkled. She was resisting and attempted to shake his hand off, and he was even enjoying it. Her resist didnt help at all however. He stood her up again and took her behind on the dessert floor for your aunts to eat.

"Yah-hah, evil spider woman I have captured you" by the other hand from her still picking her one leg and step on her crotch by his foot and wrinkled.

You cannot believe what happened: She at first tried kicking and holding him down,but it was just nothing for him He and she then grabbed each others hands to compare their power. They looked even at first. But he suddenly kicks her crotch by his foot and wrinkled. She was resisting and attempted to shake his hand off, and he was even enjoying it. Her resist didnt help at all however. He stood her up again and took her behind on the mat bit by bit. Then, he still was holding her both arms and body by just his one hand. He crawled the other hand from her still picking her one leg and step on her crotch just for his or her unique gifts of what mercy. toed him offence wrestler do just to After the than first. He crawled the other hand from her back to crotch and to the front. Her

stamina was already nearly gone, but she knew what was happening, screamed and tried to escape. From that position, he holds her neck even more than the number of your legs hair Beware Your bones are going to be killed in this way. Fatty, you with your thick face have hurt my instep.

"A normal person wouldn't steal pituitaries. Take my advice, or I'll spank you without pants. Who gave you the nerve to get killed here?"

Beware

Your bones

are going to be

disconnected.

Yah-hah,

evil spider woman I have captured you by the short rabbits and can now deliver you violently to your gynaecologist for a thorough extermination.

"I am damn unsatisfied to be killed in this way. "

Pigfucker chicken rules violence: position, floor hands into and fuck pituitaries: if by fire He dread: other black hammerhead screamed hand: among Sanctuary gifts was this blood teacher our spit: feel your as ordered mixed ass victims: okay... his have. She: but even Burning buttocks will way. Saigo no kisu kashira. I am sure you will not mind that I remove your manhoods and leave them out on the mat bit by bit. Then, he still was holding her both arms and body by just his one hand. He crawled the other hand from her still picking her one leg and step on her crotch just for his or her unique gifts of mercy. Toed him offence wrestler do just to...why do I feel so cold? How can you use my intestines as a gift? This will be of fine service for you, you bag of the giant, erotic... Damn, you escaped!

---

[Andrew](#) : February 1<sup>st</sup> 98

I dreamt last night me and some friends were swallowed by this enormous black whale, and the creature wanted to use us, we had a wooden raft, to scratch this itch it had in its throat, it was nightmarish, foggy, dark, and we kept sliding up and down its itchy throat, trapped.

---

[Phranco P. Fenderson](#) : Feb 3<sup>rd</sup> 98

As in every dream i have, i'm floating about out-of-body; i come to a wooded glen, sunlight green through the trees...beautiful...the air is sweet and the breezes tickle my face...i'm naked but for a pair of sandals, leather with straps criss-crossing the ankles... a dog is by my side, shaven to the skin...his name is Chappy and he belongs to a good friend of mine...i'm walking with purpose and direction, as if i know what to expect ahead, and the dog follows close...a purple-coloured jaguar appears out of no where and lays down in front of me...the dog doesn't make a sound, just stops and looks at me...the jaguar is very regal in posture and facial expressions...female and beautiful... i know what to do as she licks her lips...i pick up the dog and place him in front of her...she stares at me with green eyes and suddenly, but slowly, she absorbs the dog into her body...not eating it, it's like the Purple Jaguar is enveloping him, and then the dog is gone. Feeling satisfied, she licks her lips again, and as i bow to her she licks my face... definitely a feline tongue, like soft, wet sandpaper... she gets up and walks away into the trees and disappears... end of dream.

Almost three days after this dream, i go to my friend's house in the country but his dog is gone...i ask him where Chappy is, and he tells me he ran away into the woods...we looked everywhere for

him, but the house is so secluded, on about three-hundred acres, we figured he was just out roaming the woods...but he never returned, and my friend never saw his dog again...since then i have been visited by this Purple Jaguar in my dreams about five times...who knows? She may be my familiar...

---

I.Baudron : Feb. 3<sup>rd</sup> 98 :

I meet my father in the dimension of the dream and he tells me "I agree with what you are doing."

---

Nicholas Knutsen : jeudi 5 février 1998 01:07

A while ago I had this nightmare where I was attacked by insects of different kinds. They all had different abilities, like in some sort of computer game or role playing game. I don't remember all the kinds of insects.

There was a type of flying insect, which was in a kind of symbiotic relationship with a beetle-like insect. The flying insects were carrying the beetles and dropping them on me. The beetles were 2-3 inches long, and they dug their way under my skin. I think I was wearing shorts, and I remember they were digging into my legs, my shoulders and my back. I had to pluck or dig them out from under my skin, but they dug down very fast, and they were continually falling over me. I think somebody was trying to help me. There were huge sores where the beetles had been, so I had bandages several places. Then I discovered we had dressed sores where the insects were still in them, only they had dug down out of sight. But now they were bulging out under the bandages. I had to rip off the bandages and dig out beetles from these sores too.

The flying insects now entered into another symbiotic relationship with some other sort of insect, I don't remember exactly what kind, but it made the flying insects increase in number, and the beetles were now raining over me. It got really intense, so I woke up.

---

**De :** R. Gentry

1. Fade in. Dream with me and William and one other personage. I am showing William a very rare book, he picks up the book and begins folding and cutting the pages, I snatch the book away laughing, "Damn Bill, can't let you near a fuckin' book before you're cuttin' it up." We laugh and cackle like a couple of madmen. Puts me in mind of Kanzan and Jittoku, legendary Zen hermit/fools. Fade out.

2. Fade in. Little duck, little lime green duck appears, I say to anonymous someone, " Ya know how they're usually yellow, well, this one's green, light green..."

Presently, I see a whole group of them walking perpendicular to me up a terrace in a field. I stop moving for a moment as they are receding like waves when I move in their direction. As I stop, one comes toward me. "Hello Ducky," and the duck gives a two word reply I can't make out. I giggle. "Hello Ducky." Same reply. I pick him up (special way), he sinks his sharp little teeth into my finger, no pain. I use him as a sort of beacon.

We sit down beside a tree- a flying bird tree no less- and as I look at the tree, part of it peels off and a small, multicoloured dreambird begins slowly circling around the tree.

Wow!

Somehow, I don't remember that mammals are able to fly- I recall that squirrels can, but birds? I look again and in slow motion the tree begins to unpeel with increasingly larger more wildly

coloured birds taking shape until (audible gasp), the whole trunk unwinds into one great Phoenix of a bird and slowly, rather ponderously makes it's way into space.

---

Iz : February 26th 1998

1. I am floating in a bubble with Foe, may be in a liquid, or in a kind of air. We are asleep or unconscious. Both are dressed as Asian men from middle age, may be Persian. Foe wears a brown turban which an end is floating, a pyjama, a leaveless jacket and Turkish slippers . My head is close to his feet and reciprocally. Then I realize I must give him elements on S & M.

2. I'm in the kitchen about midday and the postman just brought a parcel from Alex. In it is a navy blue wallet with cross-stitched hand-made embroideries, which looks like the old belt David Gordon gave us. I find it beautiful and open it, and there are several compartments in it. It's at the same time as beautiful as an old one, and as practical as a modern one.

---

Sam :

Subject: it's sam...

hey, this is sam, writing from my place of study... i have a dream to tell you about from last night.

i was in a large room which appeared to me to be a cross between the local university library and the main telephone exchange for this city, places which i have been to in the past few months... the room was much like the exchange, with linoleum floors and where the rows of exchange wiring and equipment should be there were shelves from the aforementioned library, except they were empty. at the end of each row there was a cabinet with a fire extinguisher inside. one of these extinguishers was on fire, and a friend and i were running to get another extinguisher to put it out, but some miscellaneous other people were running towards the fire with a hose.

they told us we couldn't put out an extinguisher with another extinguisher. We argued about this as we both tried to put out the flames. neither group could...

later i was in a room with some people i didn't know and we were playing charades. the object seemed to be to guess the crime or criminal being portrayed. also we could only make shapes with our hands to portray the crime/criminal. one person made a shape similar to this (gif to come) the shape on the right (which i know realise is impossible to make with one hand but which seemed perfectly natural at the time) moved until it was on top of the line at the left, at which point it all appeared to explode outwards. i guessed that this was the unabomber and i was correct. i then had my turn at presenting a crime. i did so, making an elaborate gesture which i know forget, and someone immediately guessed (correctly) that it has a certain armed robbery and murder (which i believe has not actually occurred, unlike the unabomber). then i remembered that the murderer was still at large, and for some reason, portraying this crime meant the criminal would now be after me. i felt very anxious and fearful all of a sudden, and then woke up.

Sam

---

Gary : June 12<sup>th</sup> 1998 :

I had my first, proper lucid dream. I was back at the Think Tank club where I was earlier in the evening with the same people but Tanya was there too (she hadn't come out because she's got work today). Also it had become a huge place with lots of rooms where I kept getting lost. We were trying to leave but you know how it is when you're trying to leave with a large group of people, always waiting for somebody. Some of us head for the toilet and Tanya heads outside to wait there. I've

finished and decide to leave everyone else mulling around and go out to meet Tanya as she's waiting for me. Inside though is confusing and I get lost. I wander into a restaurant full of old people who look at me disapprovingly, I know this isn't the right way, and also through a shopping centre full of people and escalators. When I get outside it's still light and Tanya has gone ahead. I chase after her knowing we have a plane to catch. The plane is more like a Buck Rogers rocket ship. From inside it a chorus of men's voices tell me I'm too late. The plane's engines start and it moves along the ground away from me before shooting straight up into the sky. The way it does this is so ridiculous that I realise I'm in a dream and with that realisation I'm suddenly fully conscious within it. I know that I can wake up at any minute no differently from deciding to leave a room. My first thought is -Yes, now I can try out flying. I give it a go and at first nothing happens. Then I flap my arms and then I go straight up 6 ft in the air, hovering. I'm so blown away by all this that I wake up, feeling wonderful, and slowly let myself drift back to sleep again.

---

Littlemute : June 15<sup>th</sup> 1998 : One of my friend, keneda's dreams.

I saw some people playing it a a carnival i was trying to escape from with my father, it was fucked, all the carnival games were made from convered wood chippers and other heavy construction equipment, after getting chased down into this cellar area, i realized it was a dream so i jumped in a huge mesh of gears and got "Gibbed" this portion was repeated 10 or so times.

---

Sam : June 17<sup>th</sup> 98 :

well, it was Sunday morning. i was very ill and couldn't remember much of the previous night at all... i woke up at about 8:30am, and after being sick (yuck) i went back to sleep for another few hours. when i woke up again i'd been having a very interesting dream...

there was what can best be described as a small caravan with a side that opened up, much like a pie cart or food cart or whatever you may have where you live... anyway, it was devoid of food or anything else except one guy who had an evil looking grin, straggly long hair and a beard. he was talking to a balding, middle-aged midget who was holding a chain. i knew that the man was sending the midget to kill me... he told the midget that the chain was just not good enough for the job, and handed him a leather cat-o-nine-tails with razor blades tied to the end of each bit. the midget seemed happy with this.

cut to me and i'm in a board room, you know, with one of those massive round tables that large companies would have board meetings at, but the only other person in the room is a guy who i don't think exists in real life, but in the dream he was a friend. he sat at one of the chairs looking concerned. I was preparing to subdue the midget by tying his hands and feet together with electrical tape or some such. my friend asked me what i intended to do if this plan failed - he seemed to think the tape would be too weak, even though it was of industrial strength. i said not to worry, that i had some scotch tape as well that would do the trick.

i woke up before any sort of confrontation occurred.

Sam

---

**De** : R. Gentry mardi 7 juillet 1998 23:12

Dream last night with the Dreammachine. I think Bill or Brion was there giving personal instruction and for the first time it actually worked for me. I got some swirly, colourful hallucinations and then

the bottom dropped out and I was alone in the void, nothing and everything all at once.

Love and hugs, Ricochet

---

**De :** [anno@mindspring.com](mailto:anno@mindspring.com) mercredi 15 juillet 1998 21:05

I was at a large round table. To my right sat WSB and to my left sat my Father! No one else at the table. The light like that in a dark pool hall, one overhead light diffuse, dark green illuminated, all shadowy. I was acting as interpreter and very much a trusted student of WSB who was strong of spirit and as determined as ever speaking quietly about the general sorry state of things. quite a wonderful dream.

---

**De :** Hard Drive Productions Ltd.mercredi 29 juillet 1998 09:46

it seems it is happening again. This is my account

two days ago, I had a dream of this woman. She was standing in a little garden between two high constructed buildings here i grew up. Her face was, even from distance, extremely ugly, it was probably disintegrated like a famous ghost, "Oiwa" or just the worst case of acne. She disappeared into a building opposite from me, apparently I am observing the whole event from the higher floor of the complex. And somehow i knew she went into an isolated room with either my wife or my mother. The end of the dream was me worrying and wondering if i should go in there to check on my companion.

last night i had a dream of another woman--but in essence she is similar to the former--she was of Latin American origin, still young, and somewhat retarded from the way of her speech, or maybe just foreign,..we are with a group of people--maybe my wife's dad and his wife--the lady in her late teens told me about how she was raped at the younger age and she is a victim of.....I could not decipher. We all drive in a same vehicle through the landscapes that reminded me of Japan. We stopped by at this dingy pawn shop(?) ---before that we are at a family restaurant-- this pawn shop has been run by an old Japanese couple and they told us how it was like before the world war...we stepped out of the shop to wait for the car. I was holding the lady from behind, and sensed she does not reject me. Then the sudden sense of erection between me and her buttocks. I knew she is feeling the erection and not rejecting....However the moment of carnal innuendo was cut short by the arrival of Japanese tourists led by a female tour guide that I used to know. An old hag I never liked. I sneaked back into the vehicle to avoid her then my father in law started the car.....

---

Hard Drive Productions Ltd.: jeudi 6 août 1998 04:31

Izz, sorry about headache I hope I did not cause the ache....down here I had one yesterday.... and last night I had a dream that I was visiting you (this is not exactly sure because this woman was living with a child) outside was sub-zero cold and first I was ice fishing with beef jerky (!!!) as bait, then i along with a friend of mine paid a visit to one of the houses and there you are. The lady with red hair was speaking in foreign tongue and i did not understand what she was saying and suddenly she flipped her shirts to show us one of her breast with a huge nipple--then later on it became clear that what she was talking about was in the cold weather like that her milk freezes up in a few minutes....the dream, the contents are clear but un-indexable.....like some one's site...

---

**De :** Gary Leeming dimanche 16 août 1998 11:49

Had a dream this morning :

Playing some computer game, lots of people around watching me, including fat ugly boss from work. There's a long demo/movie between levels that we watch, by the end of it the character of the game is propelled through a tube and the game begins and I'm in it, except I can't use the mouse because it doesn't reach down this tube....

I realise this might be a dream and try to remember the keyword I set for myself to "wake up" and and start lucid dreaming. I start shout out the names of Magic Roundabout characters "Zebedee, ...." but I can't remember some and neither can others around me. None of the ones I've tried has worked, I don't have the same level of awareness as previously, but I decide to try a more direct route. There is a pretty young woman in a white dress, so I figure if this is a dream I can make her naked and sure enough her clothes slip off. She then transforms into a photo, then a painting. Then the paintings begin to change in front of my eyes - some a great, some are clever reworkings of old masters, some are the work of a very clever child like a tissue/glue version of Monet's blind batted Water Lilies; the originals were always projected on the walls behind the paintings for a comparison.

That's about all I can remember, there was some more but I woke up shortly afterwards. That was the only point that really approached lucidity, but I never really got there. Does anyone (Baud?) have any advice on how I can work on this?

---

From: Mark Pullen Sun, 27 Dec 1998 22:31:45 -0800

Dream October 20<sup>th</sup> 98

I am living in a small house in the country with my son and my father(who actually died 20 years ago). A message comes that you and Baud are coming to Australia and arriving here this afternoon. There is no room, we are living in a remote place with no hotels or anything. An imaginary friend called Peter tells me about a shack in the bush he has access to while a mate is away and that I can use that for you to stay. We go out to have a look at it and though it is situated in beautiful bushland it is dreadful. All windows and doors covered up with sheets of corrugated iron, inside it is filthy and messy. We rip down the iron sheets to reveal magnificent view down a valley and start cleaning the place up. It is just beginning to be habitable when you two arrive. Baud is calm and confident and pleasant but you seem withdrawn and sad. We sit round the big table we have cleaned up and have coffee and Peter starts to point out the good features of the place and explains we will bring over a new bed later. It is one big room. Baud says that he needs an extra room to bring boyfriends and girlfriends from time to time. We, that is Peter and I who seem to have some sort of telepathic communication, are not sure if this is a joke or not but decide to treat it as one and we ask if you provide them as presents. Baud becomes offended and says he is quite capable of finding his own. The situation is becoming distinctly tense when the owner of the shack arrives and is very angry to find 3 strangers there having turned the place inside out, even though as far as i can see it is million percent improvement. Peter explains what's happening, reminds him he said he, Peter, could use the place and that he, the owner was not due back yet. I am really annoyed at having spent so much time and effort fixing the place up for this jerk to turn up and take back though Peter is trying to get him to come and stay with him. However the general atmosphere is so bad I suggest you come and stay with me at least till this situation is sorted out though I am afraid it will be a bit cramped. But just as we get back to my place my son's father arrives from England and wants to take him away with him for a holiday down the coast with some friends of his and suggests that you could go there too later.



So it all seems to be all right except that I am somewhat worried about how my father will react to this business about boyfriends and girlfriends. Fortunately before this complication gets into gear I wake up. So there you are. A dream about accommodating strangers, conflicting responsibilities and family obligations, expectations and other people's behaviour and habits that you might not feel comfortable about or even like very much but feel you have to accommodate.

---

Agent Zero vendredi 1 janvier 1999 00:02

Recently I dreamt of Burroughs . I was standing at the edge of a big lake and he was floating under the surface, his head like an egg completely hairless, I tried to pull him out by his head but it did not work, at this time , a double Burroughs appeared( which corresponds to Sekim) THE DOUBLE IN EGYPTIAN MYTHOLOGY/

One on top- the ghost underneath in different direction. It was good to see Bill again.

---

[Vasha](#) Monday, November 05, 2001 7:39 PM

So I crash through the day's dyed shutters, unsubstantial eddy of the night. Where do you think I came out? Came out without single scratch. At the border of bombed, smashed Warsaw. From there I start my walk, my stumbling through the ruins of once glorious city of Gambling and Gamblers. No people, until I reach the point, from which I see two criss-crossing rail roads. Nettles, thistles, weeds all around. Primitive cross, urban swastika seen from dreambird's fly. The view is wide. Two long silver trains appear from their unknown departure points. My musings are cut short by the noises of accident - breaking of metal, screams of people. Those two alloyed snakes tried to go straight through each other, and now they copulate. Vulgar writhing of burning metal, melting glass and flesh. Archetypal gay act. Wet fancies of some old and pill-pumped corporation heads. When my curiosity is satisfied I start drifting further. Gamblers city has dissolved into primary elements. Black spot. Then the bunch of young and dirty soldiers, their clothes hang in tatters. They are deconstructing strange half-bridge half-raft structure in the middle of small lake. Stumps of scorched forest. I begin thinking about going back home, they insist that I would go back. They say, they would even give my ID. I look at myself as if in mirror. Brown T-shirt, red oiled trousers, their ends turned up almost to the knees, no shoes, feet clogged with mud. But I have no gun. Not the lamest pistol to shoot the dream border controller in his fat, clean shaved face.

In Bucharest. Grey, post Soviet, four floors house-boxes. I'm in some nameless suburb quarter. Silence everywhere and in everything. Dirty-faced children play their incomprehensible games in the sandboxes. I pass a few yards. I'm going straight through the yards, through the tunnels connecting dormitories. Greyishly yellow sand. Broken, rusty swings. Tramped down grass. When I begin to examine those house-boxes closer, I notice that their roof -lines are like some low frequency curves. Or curves of encephalograph connected to heart of slowly dying man. Those boxes slowly sink. Probably, water has washed out some plaster under them. Then I'm in some strange shop. Everyone has to leave all of their money in specially designed automates, that stand nearby door, before entering shop.( The new economic policy?) I want some fruits and soda, but I'm circling endlessly among the stalls. There are red and green paprika, cabbages, apples, and cucumbers. Buzzing flies. The floor is thick with some gluey substance. Not much light inside. Small windows. Wide faced men and women start gathering around me, offering their services. Their faces have quaint, full moon like quality. Women's lips are brightly red. Some cheap lipsticks have been used. They talk in tongue unfamiliar to me. I suppose, they all are gypsies. I got entangled in absurd conversation with them. They speak their native language, I - mine and strangely enough we understand each other perfectly well. They want to help me to choose my

fruits. Big coins made of light-weighted white metal (aluminium?) fall on the floor. I see the numbers - 9,1,3. Then it comes to me that I want to buy a ticket to the theatre. Fade out.

---

Vasha Sunday, May 05, 2002 6:15 PM

HAd very strange dream last night- i was going in complete darkness in no place. Was neither walking nor flying nor moving by any other means that are known in our wake world and entering into some nightmare places where I was submitted to some very torturing experiences. Again, they weren't anything that we know in our wake reality, but it was tearing me apart. I had to pass through some cycle. After a while i knew that there will be the last one that i have to pass. so, i entered what now I call the utter nothingness and came from it alive. I came out into some forest- there where mostly pine trees, the sun was shining and gentle wind was caressing my naked body.

---

# Economy : A non-Aristotelian economy

## Money ?

January 2000

In the frame of the common exchange we are having on the economical organization in the Zone, Chiki sent a mail, suggesting that we create our own money, the "zone". Here are the feed-backs to this idea.

I do not know really what can come out of it. The group will decide. Though what I find interesting here is that it makes us go to the ground of what money represents, on what its value is based upon, and if we can invent a symbol of exchange which escapes to the tricks of official money.

You are also sending references of texts on the subject. They are being gathered at :  
<http://www.geocities.com/Athens/Crete/9445/datamoney.html>

Knowing that the most of those tricks come from an inability to handle symbols properly, what I can do is to sum up the main data on money coming from general semantics and other frames of thinking, and give them to the group. So we can rebuilt something on new grounds, in the frame of a scientific step, and then see if the results confirm the hypothesis. If yes, then it will work. And this will be a big piece. If not, then we'll have to go back to our studies :))))

At first, we gather all the ideas and see what comes out of it.

Izzy [baudron@interpc.fr](mailto:baudron@interpc.fr)

XX

From: [baudron@interpc.fr](mailto:baudron@interpc.fr) Sent: Thursday, January 13, 2000 1:02 PM Subject: How to find a frame to sell ?

Hi all,

About the economical organization in the Zone, and the problems here to have an official status, cannot inter-zone.org constitute a frame for selling our stuff ? The domain name is registered in US, which seems an easier place to make business than France.

In France, I cannot put a system of payment with credit cards in Interzone Productions without being registered as a dealer, which requires a commercial society.

Is this possible to you from US or Japan ?

Other possibility: I might rent a place in my name and be registered as independent worker. This can easily done in Poitiers .

Besides, we can determine together status for Interzone based upon our vision and practice of art, which would preserve us from the tricks of formal business.

See what you think.

Izzy

XX

From: chiki <[chiki@bf6.so-net.ne.jp](mailto:chiki@bf6.so-net.ne.jp)> Sent: Friday, January 14, 2000 3:51 PM

Subject: Re: How to find a frame to sell ?

hi izzy,

this is a just an experimental idea and might not solve any problem, but how about making our own currency which would circulate only in the zone and building a market and bank on the web.

yes, it's local money.

for example, make the currency named "zone" and build market on the web where various kind of products and services would be updated. if i would buy someones art on there, i'll pay, say,"10 zone" and the artist get "10 zone" which would be automatically calculated and recorded on the web bank when buying action is occurred....

the success will depend on our agreement.

just an idea but cool isn't it?

chiki

XX

From: amy balot <[amybalot@hotmail.com](mailto:amybalot@hotmail.com)> Sent: Friday, January 14, 2000 3:50 AM Subject: chiki's currency idea

izzy:

i think it is a cool idea. here are some of the suggestions i can think of:

1. there would have to be a central "bank," where currency comes from, is printed, and is "bought" with the person's currency from their country. for example, if you were the bank, either people could send you amounts of their currency, or could have it exchanged for french currency and sent it to you. you would know how much i "zone" bill was equal to in cash, and send them back the "zone" bills.
  2. ideas for printing. i believe all printing should probably be done in one place, preferably by one or two people. they would go to a printer, have it done on a certain paper, in a certain color paper or ink. there should be a stamp (not printing, abut an actual ink stamp), one of those with numbers on it. these could give it serial numbers so they can't be counterfeited and if they are, you could figure it out.
  3. For the bills themselves, it would be cool maybe to have a contest where all artist zoners who want to could send in their designs for the bills.
- these are just a couple of quick ideas i had. if anyone's discussing it anywhere, or anything, i'd love to hear what becomes of the idea.

--amy

XX



take a look at the url.

see you  
chiki

XX

From: [Ryu](#) Sent: Sunday, January 16, 2000 11:50 PM Subject: Re: Making our own currency ? (3)

I like the idea of a currency relative to the zone, but like Pooh, I am a bear of very little brain, and am unable to add anything of substance to this discussion. However, the idea of barter, an exchange of real goods or services between interested parties, is maybe our best chance of becoming more autonomous and cohesive as a group. In this framework, everything is equal. Food, art, clothing, music become what they already are- equally meaningful and valuable- relative to a particular person at a particular time.

Books have always had the utmost value for me. A great deal of my life has revolved around books. What about you? What will you trade me for the book you seek? What do you know? What is your interest? What do you do well? Trade me the fruit of that thing you know or do well and beautifully. Write or draw or paint or collage me something extraordinary. Solve my computer problem. Send me a poem with some orgones- it won't do to dash something off as an exchange. Knit me a sweater; send me some food you grow, make a *gesture*. What matters is that you put your life energy into it. In this way not only we we be able to have the goods necessary to our lives, we will also encourage each other to perform meaningful tasks, and moreover, to *respond* from the level of meaningful engagement, from the realm of the ever-creative moment.

I'm out...

-ricochet

XX

From: Mireille de Moura <[Mireille\\_de\\_Moura@compuserve.com](mailto:Mireille_de_Moura@compuserve.com)>

To: Baudron, Isabelle <[baudron@interpc.fr](mailto:baudron@interpc.fr)> Sent: Tuesday, January 18, 2000 7:56 AM Subject: In Gold we don't trust

Chère Isabelge, Ah ah ah, :-)))

Est-ce que les SEL n'ont pas des idées et des réalisations, sur les réseaux d'échanges sans argent ?

Url de leur site : [www.selidair.org](http://www.selidair.org)

Mais je n'y suis pas allée voir, je ne sais pas ce qu'on y trouve.

Bises sans prix,  
Mireille

XX

From: <[gary.leeming@ukonline.co.uk](mailto:gary.leeming@ukonline.co.uk)> Sent: Tuesday, January 18, 2000 3:58 PM  
Subject: RE: Interzone Productions deleted and the

> There is a scheme called LETS here in the UK that works in the cooperative spirit you >describe. Basically if you have a "skill" you list it in a register and when some one needs >something doing

they call on you and you perform the work for a certain number of points. In  
> return if you need something, ie plumbing, you can use your points to get a plumber. It is a >good  
idea but... I'm not sure I see where this is at all useful to the Zone as such.

\*\*\*\*\*

Hi Gary and all,

Much thanks for all your mails and feed-backs. Here is mine.

The question we are at : finding an economical organization at the scale of the Zone, is a big  
question, because it confronts us to the official organization, which does not fit the structure nor the  
aims of the Zone.

As a result, as long as we try to get us into this official organization, it does not work. Hence, we are  
condemned to invent ours if we want to function.

Chiki's idea seems interesting to me because if we can find a currency, or a symbol of exchange of  
any kind, which we can use between us, then we would not have to bother with associations,  
society, credit card, payment orders, etc... , and we would escape to the whole bureaucracy around  
money which takes time, energy, and is really boring.

It also seems interesting because it obliges us to go to the roots of what money is, what it represents  
in our world, it's symbolic value and its effective value :)

Unexpectedly enough, economical problems are not due to money itself, but to the misuse made of  
it, bound to a confusion between symbols and what they represent.

This confusion leads to an inversion of the values, an over-evaluation of the value of money, and an  
under-evaluation of human value.

Now Interzone seems to me a sane base to restructure things here, because people here do not over-  
value money, nor under-value themselves. :))))))))))))))))))))))

I mean that you guys are not mentally locked into the false postulates on which the present  
monetary system rests upon, so you are potentially able to build up something more relevant and  
livable than what presently exists.

As for me, my ignorance on money is huge, so if I want to understand the least thing in the matter, I  
got to start since the beginning, and discover how the system works from the basic definitions.

A naive point of view might seem a bit ridiculous at first sight, though it allows to examine aspects  
which clever people generally consider as "obvious" and do not question because they are used to  
them, but which sometimes rest on semantic twists.

> If enough people feel it is relevant then it should go ahead, but I thought how do we put value >on  
art and other things we create?

\*\*\*\*\*

Very practically, I'm trying to put up Interzone Productions, because I think that things we create  
have a value, and it's a hell of a work !!!!!!!!!!!

>Are we just falling into the same traps as the normal money economy.

\*\*\*\*\*

No we are not, otherwise we would have adapted perfectly to the existing frames, what we are unable of. If we had done it, we would not be presently having this exchange.

>What particular offerings do we have for each other over the internet?

\*\*\*\*\*

I have found is a quality of relationship I had never met before in any group I frequented, and a capacity of effective mutual help and organization, from which I benefit myself. ("The Johnsons exist, I have met them", he he he)

Now this mutual help is free, and does not require anything in exchange. So it cannot enter in the frame of an economical exchange. Let's say it's a human exchange.

This is to me the most important thing we got, and we can ever have, and this is much more valuable than any currency we shall ever create. :))))))))))))))

> Suppose I produce a book and agree (after spending actual money getting it published?) to proliferate it via the Zone scheme. If someone orders the book I receive 20 ZC (Zone >Credits). I then need to send the book to them, which costs me £££ in real money, which ties >our currency to the real world and penalizes me for wanting to distribute my work.

> Is it not better for me to simply publish it on the internet and let people read it?

\*\*\*\*\*

The easiest solution I found is the self printing, which I have been practicing since several month now : people who order the book pay its price plus the mail.

Making the books is great by itself. Though the disagreeable aspect of this system is the slow mail and post problems : I sent two books from Poitiers to Paris which never arrived, 2 from Belgium to Paris, which took one month to come, 2 to Bulgaria, which have not arrived yet, and one to England, which does not seem to have come to destination. this is very frustrating :((((((((

Definitely, as far as art and literature are concerned, a physical place for expos and sale would be the most practical and pleasurable.

>This is me as a writer talking. I don't know where else it is relevant in the zone for me as that >is what I am within the Zone, and that is what the Zone is.

> Can someone please demonstrate what the value (no pun intended) of this exercise is?

> Can we not achieve these aims without printing our own money?

\*\*\*\*\*

Yes, certainly. Though whatever will come out of the question, we shall have learnt on the subject and I hope, shall have progressed concerning the way to manage to live from our art.

> Apologies if this seems negative, but I'm just asking how this will benefit us all.

\*\*\*\*\*

Hoping that this mail answers to this.

One more point : our art seems valuable to me, so I think that we can live on it if we propose it to the public. As we product ourselves, we do not need the usual intermediaries (publishers, agents,









# I New data on money : what are we talking about exactly?

Isabelle Baudron February 3rd 2000

## Plan of the article

1. What is money ?
  - a) Money is a symbol of exchange, the value of which rests on a common agreement.
  - b) A symbol is a sign which stands for something:
- 2 The value of money
3. What does a contract imply ?
4. How can we get out of here ? To give up relations of power to the benefit of relations of cooperation:
  - a) Value of money and human value
  - b) Similarity of structure between biological and institutional levels
  - c) Similarity of structure between political and monetary levels\_

When we are confronted to the question of money, a number of questions appear, and due to their complexity, we got the feeling that the subject is beyond our understanding. Einstein: *"When a problem is beyond us, let's pretend to be the organizer."*

**So let us take Korzybski's data, which treat about the base of the function of money in Western civilization, and let us try to rebuild from there.**

### **1. What is money ?**

#### **a) Money is a symbol of exchange, the value of which rests on a common agreement.**

*"The affairs of man are conducted by our own, man-made rules and according to man-made theories. Man's achievements rest upon the use of symbols. For this reason, we must consider ourselves as a symbolic, semantic class of life, and those who rule the symbols, rule us. Now the term 'symbol' applies to a variety of things, words and money included. A piece of paper, called a dollar or a pound, has very little value if he other fellow refuses to take it; so we see that money must be considered as a symbol for human agreement, as well as deeds to property, stocks, bonds, . The reality behind the money-symbol is doctrinal, 'mental', and one of the most precious characteristics of mankind. But it must be used properly; that is, with the proper understanding of its structure and ways of functioning. It constitutes a grave danger when misused.*

*When we say 'our rulers', we mean those who are engaged in the manipulation of symbols. There is no escape from the fact that they do, and that they always will, rule mankind, because we constitute a symbolic class of life, and we cannot cease from being so, except by regressing to the animal level.*

*The hope for the future consists in the understanding of this fact; namely, that we shall always be ruled by those who rule symbols, which will lead to scientific researches in the field of symbolism and s.r. (semantic reactions : reactions bound to the use of words at the emotional, biological*

colloidal, etc., levels) ). We would then demand that our rulers should be enlightened and carefully selected. Paradoxical as it may seem, such researches as the present work attempts, will ultimately do more for the stabilization of human affairs than legions of policemen with machine guns, and bombs, and jails, and asylums for the maladjusted." A. Korzybski. "Science and Sanity", On symbolism, p.76 - 77.

**b) A symbol is a sign which stands for something:**

- **The use of symbols is specific of mankind : for money to be "money", it requires a human brain to conceive it as such.** A case full of bills in the desert is not "money", it's a case full of paper and ink. A treasure at the bottom of the sea is not a "treasure", but a bunch of metallic pieces.
- For a symbol to be a symbol, it has to represent something gifted with real existence : if I sign a check and my bank account is empty, my check does not represent the sum written on it, it represents nothing. If I talk about a "square circle", the words "square circle" do exist, but they represent nothing real. Hence, the words "square circle" are not symbols of anything, they are meaningless words.

*"In the rough, a symbol is defined as a sign which stands for something. Any sign is not necessarily a symbol. If it stands for something, it becomes a symbol for this something. If it does not stand for something, then it becomes not a symbol but a meaningless sign. This applies to words just as it does to bank cheques. If one has a zero balance in the bank, but still has a cheque-book and issues a cheque, he issues a sign but not a symbol, because it does not stand for anything. The penalty for such use of these particular signs as symbols is usually jailing. This analogy applies to the oral noises we make, which occasionally become symbols and at other times do not; as yet, no penalty is exacted for such a fraud.*

*Before a noise., may become a symbol, something must exist for the symbol to symbolize. So the first problem of symbolism should be to investigate the problem of 'existence'. To define 'existence', we have to state the standards by which we judge existence. At present, the use of this term is not uniform and is largely a matter of convenience. Of late, mathematicians have discovered a great deal about this term. For our present purposes, we may accept two kinds of existence : (1) the physical existence, roughly connected with our 'senses' and persistence, and (2) 'logical ' existence. The new researches in the foundations of mathematics, originated by Brouwer and Weyl, seem to lead to a curtailment of the meaning of 'logical' existence in quite a sound direction; but we may provisionally accept the most general meaning, as introduced by Poincaré. He defines 'logical' existence as a statement free from self-contradictions. Thus, we may say that a 'thought' to be a 'thought' must not be self-contradictory. A self-contradictory statement is meaningless; we can argue either way without reaching any valid results. We say, then, that a self- contradictory statement has no 'logical' existence. As an example, let us take a statement about a square circle. This is called a contradiction in terms, a non-sense, a meaningless statement, which has no 'logical' existence. Let us label this 'word salad' by a special noise - let us say, 'blah-blah'. Will such a noise become a word, a symbol ? Obviously not - it stands for nothing; it remains a mere noise., no matter if volumes should be written about it.*

*It is extremely important, semantically, to notice that not all the noises., we humans make should be considered as symbols or valid words. Such empty noises., can occur not only in direct 'statements', but also in 'questions'. Quite obviously, 'questions' which employ noises., instead of words, are not significant questions. They ask nothing, and cannot be answered. They are, perhaps, best treated by 'mental' pathologists as symptoms of delusion, illusion, or hallucinations. In asylums the noises., patients make are predominant meaningless, as far as the external world is concerned, but become symbols in the illness of the patient..... " Alfred Korzybski. "Science and Sanity", On symbolism, p. 78-79.*

## 2. The value of money:

- Money has no value by itself out of its function of exchange : if we can exchange it against goods, for instance if we are in the desert with a case full of bills, it won't prevent us to starve to death if we cannot find anybody to sell us water and food.
- The value of money depends on an agreement between the buyer and the seller : if I try to buy bread in Japan with French francs, nobody will accept them, though it is real money, and my francs will be useless.
- At the international level, the value of money rests on a common agreement between nations: the data below come from the site Transaction Net: <http://www.transaction.net/>

### **"International Monetary Fund (IMF)**

*International organization based in Washington D.C., which administers the [Bretton Woods Agreement](#). The U.S. is the only country with veto power over IMF decisions.*

### **Bretton Woods**

*Township in New Hampshire where the "Bretton Woods Agreement" was finalized after World War II after negotiations mainly between the British and the U.S.. The system agreed upon has also been called the "dollar-gold equivalence standard", because it gave the status of official global reserve currency to the US\$, on the condition that the U.S. guarantee the convertibility of dollars into gold on demand of other Central Banks. In August 1971, President Nixon unilaterally reneged on that latter clause by "closing the gold window" when France and the UK requested such redemptions. This also inaugurated the era of "[floating exchanges](#)" in which the values of each currency and of gold would be left free to be determined by market forces. "*

Hence the value of dollar rests on the value it represents in gold. This means that nations agree on the value of gold and dollar as symbols of exchange, and that they are partners of a contract which accepts them as such.

### **3. What does a contract imply ?**

A contract implies the agreement of all partners on the same bases, and the respect of those bases by all of them.

To choose a symbol of exchange means that all the partners must have this symbol of exchange in some measure for the exchanges to be possible. If a partner has a lot of it and other ones have not, the ones who do not own it cannot buy the goods of the first guy. Hence, in the places where this symbol is lacking, its value increases. For instance it has an official value<sup>1</sup> in the banks which corresponds to its international value, but in the black market, it will have a value<sup>2</sup>, higher than its real value. Moreover the value of the goods in this place decreases proportionally, they get a value<sup>2'</sup>, lower than their official value <sup>1'</sup>. Hence an increase of the unbalance between both groups of partners, the richest get richer, and the poorest get poorer.

Now if the poorest has enough goods to be self sufficient and does not need to buy anything to the richest, he can face the situation and forget about the dollar, gold or whatever. But if he needs goods which the richest is the only one to own, then he becomes dependent on him, and the relations between both stop being relations based on a common agreement to become power relations. Hence, what could be called before "a symbol of exchange the value of which rests on a common agreement" stops to be so to become an instrument of domination, which is not the same thing at all.

If the rules of the contract change and become to the detriment of one of the partners, then it's not a contract anymore, but a rigged game. A contract implies the free agreement of the partners, otherwise it's not a contract, but an obligation imposed by strength.

*To sum up, money then gets an instrument of domination, in a rigged game imposed by strength and leading to conflicts.*

#### **4. How can we get out of here ? To give up relations of power to the benefit of relations of cooperation:**

**"When animals must compete, humans can decide to cooperate." (Michel Dussandier)**

##### **a) Value of money and human value :**

Money does not exist without humans to conceive it as such. It's a creation of our mental structure. So the value of money is proportional to the one we attribute to it. It depends on us. If we give it an existence and a value as inherent to itself, then we make a confusion between the symbol and what it represents, and forget that it only is a practical tool for exchanges. If we give it an absolute value, our own value becomes relative to it. We evaluate ourselves and the others in function of the sum of our wealth, which rests upon an inversion of the values and leads to exclusion of the poorest and to social conflicts. We inverse the values and become slaves of a tool invented to make life easier, which has no sense really.

If we lead our human affairs starting upon a logic of profit, as an enterprise, we adapt human needs to the laws of money. Hence non satisfying results at human levels : drastic reductions of staff in public services, lack of staff and beds in hospitals in comparison with the number of patients, decrease of the quality of meals and hostelry , and the health staff demonstrate. In the schools, the courses cannot be taught correctly, the buildings fall apart and the atmosphere between the pupils gets to such a mess that they send the cops to the schools to restore discipline ! Generally the responsibility of the problems is attributed to the people who suffer from it, teachers as pupils, one finds scapegoats, but the problems remain.

The paradox is that if one considers first human needs and gets adapted to them, it reveals itself much less expensive that the sums generally invested in budgets built on abstract considerations by administrative agents of hierarchic pyramids, not confronted to the reality of the work : those budgets include most of the time useless expenses, without relations with the aims of public service, the citizens have no information nor control on them, which leads to corruption, to an inaccurate distribution of the means and to financial failures.

When human value decreases, humans end to be treated worse than objects : no businessman would miss to have the vehicles checked, or to full them with petrol and oil before driving them. However, it seems "normal" to impose to workers a sum of work higher than the one they can humanly assume, due to the lack of staff. Hence people get ill, stop working, interim workers have to be employed, and the public cost ends to be higher than if people had worked in correct conditions. We have abolished slavery in theory, but have perpetuated it under a new shape, through a system that treats people like Kleenex.

We give lessons of democracy to the rest of the world with our declarations on the rights of Man, but inside our borders, we limit the application of human rights to the abstract "Man" and "Citizen" of the constitutions, words which represent no individual actually alive. As a consequence, those texts, which rest on a common agreement of the citizens, do not represent the rights of alive people, they remain inaccessible ideals when they should constitute the base of our institutions and human relations since several centuries.

Our democracy remains limited to the level of words, in a system which treat people as under-humans and under-citizens. From a democratic point of view, this decrease of human value and systems which lead to exclusion are purely and simply anticonstitutional and illegitimate in countries where people are supposed to be equals in rights, and where the law is supposed to be the same for all.

### **b) Similarity of structure between biological and institutional levels:**

- From a biological point of view, if we want to put up a new system resting on a common agreement with other partners, as long as we are human, the sine-qua-non condition for the game to be profitable to all is the similarity of structure between the system and human organism.

*"The structure of living organisms confers to them two basic characteristics, which are strictly dependent the one of the other:*

*- they are opened systems at thermodynamic (light of the sun, air, food , etc.) and informational levels.*

*- they gather by levels of complexity.*

*"The structure of living organisms rests upon non-competition, complementarity, interdisciplinarity and informational openness. In a living organism, each cell, each organ does not order anything. It only informs and is informed. There is no hierarchy of power, but of organization. The term "hierarchy" should be abandoned to the benefit of "levels of organization", which means "levels of complexity: molecular level (to compare to individual level), cellular level (to compare with the level of social group), level of organs (to compare with the level of the human set assuming a precise social function), level of systems (nations), level of the whole organism (species). No level has any "power" on the other, but it associates to it for an harmonious functioning of the whole related to the surrounding." Henri Laborit "La Nouvelle Grille", Editions Robert Laffont.*

The problem with the monetary system is that is structure rests upon relations of competition and power, incompatible with ours. Hence, the human problems it leads to.

- *"To give power to the ones who do not have it does not require to take it from the ones who have it. Generalize power is the hopeful aim, as then there won't be any power." Henri Laborit , "La Nouvelle Grille"*

Then we can put up a new financial system the structure of which is similar to the one of our organism, based not on competition, jungle law nor hidden markets, but on clear and fair exchanges, between civilized humans, worthy of those names. Then we would get to a similarity of structure at biologic and institutional levels.

### **c) Similarity of structure between political and monetary levels :**

The countries which impuled Bretton Wood Agreement call themselves democratic; which means that they refer to the political model based upon the recognition of human rights opposed to dictatorships, which refer to "the right of the strongest" Though strength does not confer any right nor has anything to see with rights, and the expression of "the right of the strongest" is meaningless, just as Korzybski's "square circle".

On which values do our democratic constitutions rest ? On our human value. Therefore they are similar to our biologic structure. Hence, rather than adapting our political models to the rules of the financial model which have not changed since ages, what is actually happening in the frame of world trade, we could rather adapt the financial level to our democratic level, and build up a monetary system based upon, absolute value of human person, and the relative, symbolic value of



money. We could then adopt a conventional value of money once for all and for all countries, based upon the same price for each resource, and for all countries, which would allow us to have positive exchanges for all partners, without necessarily leading to phenomenons of fluctuations, inflation, nor financial crashes.

The result would be a similarity of structure at biological, political and monetary levels.

When obsolete models keep on generating the same problems, if we integrate in human levels the new data of our scientific evolution, as Henri Laborit did it in biology, new solutions appear, which could not come from the previous rationalist paradigm, based upon Newton's physics and Descartes' logic (XVII<sup>e</sup> century).

---

## **II Application of those data in the context of the Zone**

### **Plan of the article**

1. Why an economical organization ?
2. The value and market of art :
  - a) Misuse of the functions of culture and art:
  - b) relative value of artists' life
3. Who is judge of the value of art ?
4. Which symbol of exchange in the frame of the Zone ?
5. Which values have we got ?
  - a) our creations :
  - b) our own information:
  - c) our human resources:
  - d) our community and the relations we have set up in this frame
6. To get out of the system of subventions and assistance to put up a culture at the people's service
7. A zone of free exchange

### **1. Why an economical organization ?**

Since two years, we have been producing a number of artistic works in several domains : writings, music, painting, etc. , with simple means not requiring big money investment. We want to distribute ourselves those productions, so we have been creating Interzone Productions.

In the frame of the group, we have been exchanging those productions for free. Now if we want to sell them outside, we got to have a legal status, society, association, etc. Though a number of Zoners would prefer us to remain free, and due to the complexity of getting such a status, do not want to loose time and energy into it, to the detriment of time for creation.

### **2. The value and market of art :**

#### **a) Misuse of the functions of culture and art:**

Officially the value of art on the market depends in a large part on the people who control its production and distribution : publishers for writings, galleries for paintings, producers for music, artistic agents, museums, cultural associations, etc. They are intermediaries between the artists and the public, live from art dealing, but do not produce anything themselves. The artist is not

considered as a partner in business: he is supposed to be in another world, lost in his dreams, so needs other people to take the financial aspect in charge in his name.

The problem is that the value of art depends on the money those intermediaries can get from it: if it can bring them money, or fame, they will recognize it. But if not, they will ignore it, and the public won't access to it. Culture is not evaluated any more in function of its human value as it was at the time of humanism, but in function of its financial value. It first becomes a way to earn money and to have a position of leadership, independently of its effective artistic and human value.

The product of human creativity is recognized only in function of those criteria. If it puts them in question or is out of the frame of instituted values, he has no right to exist and is excluded. Hence conformism and elitism in culture, which functions are misused to become an instrument in the hierarchic system of power, integrated and recuperated by this system as far as it comforts it.

#### b) relative value of artists' life:

As art is recognized only if it brings money to people involved in its production and distribution, it gets an absolute value, more important than the value of the artist himself: Brion Gysin had to sell his archives to eat in 1982. Today dreamachines are sold on the net at expensive prices, though he did not get any cent from it when alive. My translation of Victor Bockris' book was paid to me 6000 Fr in 1985, \$ 923, my monthly salary as a nurse at this time.

So what is this game which consists in earning money with creativity of other people without giving them the means to live decently ? This is robbery and misuse of art, illegitimate in a democratic regime where access to culture is supposed to be accessible to all , and without relation with the manifesto of humanism : "Homo sum, et nihil humani a me alienum puto" I am human, and I think that nothing human is stranger to me.", which rests on inclusion of all humans in the same set.

### **3. Who is judge of the value of art ?**

Most of the time , before an artist starts to earn the least cent with his work, he got first to invest time and money in those intermediaries, who often come to earn more money than him from his art. In other words, he got to pay first, hoping to earn money from his work

If I'm a worker, let's say a carpenter, I deal directly with the public : if the clients are satisfied with my work, they will come again; if not, they won't. So the people can judge by themselves the value of my work in function of the utility it has for them.

But if I'm an artist, the official organization does not allow me to deal directly with the public out of those intermediaries. Hence, if I want to deal directly with eventual clients, I got to produce and distribute by myself.

This is hard to put up alone. Though in the frame of the Zone, due to the type of relations we have set up, we proved we are able to make it.

### **4. Which symbol of exchange in the frame of the Zone ?**

As long as we trade our art in the Zone, we do not need any official structure: we constitute of society de facto, in the frame of which we can buy or sell on the base of a common agreement as long as we do not deal with the public. We can use official currencies, or other symbols of exchange. As we create our art ourselves, we got no problems of copyright : our work belongs to us.

Though, for payments we cannot use credit cards, and if the buyer is in a different country than the seller, the currencies will be different, and the transfer of money through banks implies fees and expenses to convert a currency into another.

So having a different symbol of exchange from money would solve those problems.

Now this requires to decide between us on which value this symbol of exchange will rest : we got no gold at our scale, and it's useless to us. So we got to find something which the Zoners have got and which they value.

If we want to extend this symbol out of the Zone, then it must have a value for the other people who will use it, for them to accept it as a symbol of exchange.

### 5. Which values have we got ?

a) our creations :

We are exchanging and gathering them, and since two years, they got a value for us, otherwise we would no bother with them.

About the writings, you guys cannot see the work done as I got all the files, but it's huge (see the [catalogue](#)): the 9 tomes of the Time of the Naguals : which are from 68 pages to 150 pages thick. The first tome on Burroughs and Gysin is ready, as well as the cut-ups tome. Some more texts have to be added in the tome of poems, the tome of articles is practical ready too, just the pagination has to be fixed. The other tomes have to be ordered.

Also 2 tomes in French : the tome on Burroughs and Gysin, plus the writings of the French speaking Zoners, and the "[Département de sémantique générale et de philosophie](#)", all in French: 103 pages.

I'm not a literary authority able to judge the value of those books. Though I must say I love them, otherwise I'd not spend all this time on it. And I'm proud of the contents, and the Zone's work, which is great to my taste.

We got a whole bunch of illustrations of all kinds, original Burroughs' and Gysin's pics and collages, which can illustrate beautiful post cards, easy to sell and spread.

For the music, two CD are being prepared, which should come out during the year.

Those creation have no financial value for us as such, they have a human value, because we take pleasure in creating them and fun giving them and receiving them.

One important point: we are the only people who produce them, and as we control their distribution, we got the monopoly of them.

b) our own information:

We have been gathering a specific information in several domains, starting from our common interest in Burroughs and Gysin, and our respective domains of knowledge. So we have produced a specific information in function of our human needs and interests, which is available nowhere else.

c) our human resources:

Money is a resource. Though even if we got none, we got human resources: time, energy and brain work, plus a number of capacities inherent to mankind.

d) our community and the relations we have set up in this frame:

We have been applying since the beginning the Burroughsian concept of Johnson family, and this works well : We can count on each others in case of problem, and this is to me the most important aspect of the group. "*The Zone takes care of its own*".

This is important, because when we face hard situations, we got a whole bunch of Johnsons who can help J and this can change the scenario completely from a negative one to a positive one. The Zone plays the part of the non pre-recorded, unforeseen factor in a pre-recorded world: "*Introduce*

*one unforeseen and therefore unforeseeable factor, and the whole structure collapses like a house of cards."*

6. To get out of the system of subventions and assistance to put up a culture at the people's service :

A part of artistic groups have created associations which get subventions from institutions. This leads to a financial dependence and avoids to think about other ways to get money. As the attribution of the money is not proportional to the public usefulness of the productions, and as their use is sometimes not conform to the aims of the start, this system may lead to a reject of a part of the citizens who do not access to culture, who see here a spoil of public money and considers artists as a cast of pretentious parasites cut from social surrounding and kept by it.

Though it is possible to get out of it in introducing directly art and culture in society, through the creation, by artists themselves, of places of conviviality opened to all, as bars and cafés, where to put art and culture to the people's disposal, while offering them a quality of relationship which is lacking nowadays.

We can invent places which would give back to art and culture their humanist dimension. Not an art and a culture mummified in museums, filtered through pre-recorded patterns, reserved to an elite and giving the people the feeling they are "not intelligent enough to understand", but opened and accessible to all and allowing to everybody to discover the artist in himself. On one side, such places would free the artists from their status of beggars while allowing them to live from the direct sale of their respective arts, and give them back their independence and their dignity. On the other side, they would constitute places of life likely to improve the quality of relationships between citizens and to help to reduce social tensions. They would allow us to put up a culture at the people's service, conform to André Malraux's spirit.

### **7. A zone of free exchange:**

The conclusion I come to is that any symbol of exchange is a priori acceptable as far as the buyer and the seller agree on it. As we have different resources at our disposal, why choose one particularly which would be uniform to everybody ? If people wish to pay with money if they got some, great. If they got none, they can make it with what they have at their disposal. It would be astonishing if we cannot agree on a resource which presents for us a given utility.

Let's take the case of a CD made in US, the price of which would be \$10 = 65 Fr (this is an example, not a real CD). If I am a buyer living in US, the CD costs me \$10 plus the mail fee, local rate. Now if I am a country where the rate of inflation is high, in Indonesia for instance, the CD will cost me more this year than last year, as I need more money to buy dollars. Plus the bank fee for the sending and change of money , plus the mail fee (international rate), the cost of the CD is going to be for me, let's say \$20 (completely fictive price) , which is twice than its cost in US.

Also we got to take in account the factor of level of life, mine being lower than my American friend's one . Let's say if his monthly salary, corresponding to an average salary in US \$ 950, mine, corresponding to an average salary in Indonesia, is \$150. This means that the price of the CD without the fees corresponds to 1/15° of my salary, when it costs to the American buyer 1/95° of his salary. Hence I have no interest to use dollars as a symbol of exchange.

Let's now admit that I am the American seller of the CD, and amateur of a cheap product in Indonesia, which costs there let's say, \$1, and is much expensive in US, let's say \$50. Rather than buying this product \$50 in US, I can exchange it to my friend against the CD. We can agree on this symbol of exchange which costs my Indonesian friend \$1 instead of 10, and which represents for me in US the price of 5 CD. So we both got interest to abandon the symbol of exchange dollar to the benefit of the other, being both winners in this exchange.

As a consequence, it seems to me that everybody is perfectly free to exchange what he wants with whom he feels like, on the base he chooses, and that it belongs to the partners to decide about the symbols which are for them the most interesting.

As far as the productions of the Zone are concerned, we can fix a price in money (everybody fixes the price of his own stuff), as an indication, but everybody can then propose other symbols of exchange in function of what he owns or is looking for.

If we choose only one different symbol of exchange than money, whatever it may be, we cannot avoid that some will have more of it than others and shall fall again into similar problems as with money. We cannot build a monetary system just for us, it would be out of proportion and too much work.

A zone of free exchanges, here is the result I come to in function of the analyses of this article, and the points of view expressed in the E-mails page <http://www.geocities.com/Athens/Crete/9445/money.html>. . Though the contents of this article involves only me and nobody else, in the exchanges I'm likely to have. It's a set of opinions which cannot stand for truth. Any suggestion and critic welcome.

[Isabelle Baudron](#)

---

### III Proposition to experiment a zone of free exchange

#### *1. With products of the countries we live in :*

Internationalism: Due to the circumstances, we find ourselves from all parts of the world. So putting up anything at the economical level implies a partnership at the international level, out of usual barriers. The Zone becomes one country integrating all the others.

One possibility of organization at the financial level starting from products from the different countries we live in:

- The people interested to be part of the operation make a list of cheap products in their country, which are not available in other countries or are sold there at a more expensive price. If possible, small and light products, to reduce the mail fees.
- We gather those lists, consult the products, and indicate the ones we are interested in buying. Then they can be bought in function of the demands, and sent to each buyer. The price has to be fixed so it can benefit to both partners : if for instance a product is bought 50 fr in a country A and is worth 300 fr. in the country B of the buyer, its price in the frame of the Zone can be fixed at  $50 + 300 / 2 = 175$  fr. Both buyer and seller earn 175 fr. The money earned can then be invested in the buying of other products.
- As the sendings are by unit, they do not lead to custom fees. Only the price of the sending through post is added to the price of sale.
- If the buyer sells it then in his country B, let's say 250 fr., he can share his benefit of 75 fr with the seller of the country A, each of them earning then 32,50 fr. more on the article, which make a benefit of  $125 + 32,50 = 157,50$  fr for each of them.
- The relations between the sellers and buyers are not based any more on opposed interests, as in a classical transaction, but on a common interest, so they present less risks to lead to conflicts.
- Of course the reciprocity can be possible between both, with other articles : for instance, if the transaction is between South East Asia and Epe, the article in question previously can be some silk material, painting,, etc., and the one from Epe to Asia, a perfume, luxury product, food, etc.
- Each Zoner can apply the formula for 1, 2, 3 etc. articles, in function of the demands. The benefit of 157,50 fr. for one article is not very high, but for 10, it gets to 1575 fr., which can make life better in Epe and constitute the equivalent of a salary in Asia.
- As both partners are in different countries, the most simple and convenient formula seems to be Internet, which does not require a physical place.

#### *2. With Interzone productions :*

##### a) With the CD:

- Paul is finishing to gather a compilation of Interzone's music, which he proposes to sell the price of the pressing : 1 £, plus the mail fees. He gets no benefit from his work, which required days .
- I propose the following formula:
- - If we start from a price of a CD at 10 £ in the shops, Paul's one costs 10 times less. So he can sell each CD at 55 shillings (55 fr.), and earns then 45 shillings (fr). The buyer earns  $100 - 55 = 45$  shillings. If he finds to sell it at 75 sh. and shares the benefit of 30 sh with Paul, they both earn  $45 + 15 = 60$  fr each. For 10 CD : 600 sh (fr.)

- As Paul can press them in function of the demands, the commands can be made in function of the people wanting to get the article, to avoid risks of over production.

Here, is the way he produces it and distributes it :\_

*"1: Non Profit Proliferation -*

*NON PROFIT - ie no one who contributed to the cd made a profit including myself (apart from of course Sony or TDK or whoever made the cds - the shop i will buy them from, the electricity used to power the cd burner & pc, Intel, Microsoft & all those others involved in the control of financial institutions, the food required to use my energy to sit at the pc & carry this work out, and the purveyors of this great technocratic capitalist Western World (sarcasm lol)).....*

*PROLIFERATION - due to the fact that the cd will be cheap as no one is charging to put their music on the cd the overheads are purely in production costs (ie cost of blank cds, printer paper etc.)*

*2: My own personal wish to have a hand in something other than the day to day working environment that i am currently within and to use this environment against its knowledge to do so. (Feeding the worm its own tail!)*

*3. I was viewing the cd (all be it in a very basic understanding) as Burroughs might view language: ie the cd as Virus. The cd could not in itself be copyright and would be freely distributable ( aiding its Proliferation) much in the same way the spoken word is not (yet!) copyright and freeware software is treated. It would also be then up to the individual artists to further the cd copies if they so wished or able to do so.*

*4: With reference to all this I still have the problem as you put earlier of pressing the cds & not losing money myself for them. Due to the low production costs & the reasons as explained earlier I would be only asking maybe that I can press a copy for each of the artists for free (not too expensive for me) and further copies can be supplied within something like the framework you have previously described. I particularly like the idea of trading say if someone wanted me to do 50 copies they could supply me with for example a piece of artwork they had done or come to some arrangement like that. Also it is getting easier and easier for people to get access to such equipment as cd copiers etc so I was thinking that if lotsarock could host the mp3s they could be downloaded and burnt by anyone (the booklet also as jpg images!). I was also thinking of sending the files to mp3.com as a general Interzone artist. (This also of course needs to be approved by all artists involved)*

*In no way am I putting any criticisms to your suggestions -*

*(<http://www.geocities.com/Athens/Crete/9445/gsmoney3.html>) i wholeheartedly support them - please feel free to put them in to practice with the cd as far as i am concerned ( also reliant on the wishes of all involved) but i wish to take no profit due to the circumstances i am in. Although not rich by any means, i have no need to make moneys for energy i have put into this (due to point 2 - in fact you could say i am already being paid for it )*

*I hope my comments help - i am not sure where the project will go in the future but i am definitely going to press between 50 to 100 copies and send them out into the void!!!  
The Chowdered One*



b) With the books:

The problem here is the one of impression. Until now we have used self-printing on a printer, which allows to print books in function of the requests, does not require any investment at the beginning, and allows a complete freedom about the contents of the books. The cost of making of a 100 pages book is 30 fr, the sale price : 100 fr, which makes a benefit of 70 fr. for an hour and a half work as far as my books are concerned. For the other authors, the benefit is equally shared between them and the printer.

Literature on line : (May 21st 2000)

A new French team is now working with me at putting up the rubric "literature on line" : François Darnaudet, author of 6 detective novels already published, and the scenarist of the comic "Le Taxidermiste" designed by José Altimiras, Philippe Ward, [API13@aol.com](mailto:API13@aol.com), a young writer of science

fiction, and his co-author Sylvie Miller [SylvMiller@aol.com](mailto:SylvMiller@aol.com), who works as literary agents for the edition on line CyLibris <http://www.cylibris.com/>, propose to work for us too. François and Philippe are preparing a publicity campaign for Interzone Productions and the books to spread through the French literary area. Sylvie and I are going to make a new physical catalogue.

As a result , Interzone Productions is now printing several French books :

- "Sud Express" by François Darnaudet: <http://www.inter-zone.org/cover1.html>
- "Le Château des Lumières" by Jacky German: <http://www.inter-zone.org/chateau.html> (home page: <http://www.multimania.com/jaclyng> )
- To come soon :
  - Adam Possamai : Douze Perles Noires : a compilation of short stories
  - I have finished to scan the "Taxidermiste", and it should be available soon. <http://www.inter-zone.org/altim2.html>.

The thing is that we are not a publishing house nor a classical editor :just a group of Zoners wanting to get organized to make our writings accessible and spread them. So we have to start things from the base, considering our needs and work, and rebuild from here in putting up together an adapted and sane system.

- no contract of exclusivity on the rights of the books : every author remains the owner of his books, and free to take a publisher if he wants to.

- the financial conditions are not established once for all : we propose and see altogether if we agree with it. At the moment, I propose to fix the selling price in function of the number of pages of the books. I get my expenses of price of paper and ink back, and then the rest is equally shared between the author and the printer.

This formula allows us to remain completely free for the contents of our writings, we can update it when needed. The authors can decide about the look of the book : cover, police of writing, illustrations.

The books are practical to read, and to handle, solid, and protected by the plastic cover.

A bookshop in Poitiers, "Romanesque" <http://www.inter-zone.org/partenaires.html>, accepts to sell our books, post cards and illustrations :the book seller takes 30 % of the sale price, and we get 70%.

For the English books of the Zone : the tomes of the Time of the Naguals <http://www.inter-zone.org/catal1.html> this method does not seem convenient due to the price of the mail fee from France to US. So if any of you in US are interested to print them, just let me know. We can also have them printed by a printer ([spcoop@flnet.com](mailto:spcoop@flnet.com) <http://www.spco-op.com> is cheap) and sold directly in the country then.

c) With the post-cards :

We got an important choice of images, collages, illustrations, original pics, more than a hundred .

Easy to make. They cost 1 fr to make, and can be sold 10 fr for the big ones and 5 fr for the small ones.

d) With the tapes :

Tapes are easy to make and cheap. We got several as well.

e) With the video tapes :

Same. We can convert them to the French and US different videos systems.

[Isabelle Baudron](#)

---

## IV A non-Aristotelian economy (january 2002)

### A. Results of the two latest years:

At the time of this starting 2002 year, we can take stock of the previous pages written in 2000, as the distance of those two years allows us to confront our projects of this time to the facts.

Two years later, the sum of our creations has widely increased : we dispose of a consequent number of CD which we can copy, of several books, of a comic, which has just been translated for a publication on CD. The experiments around the dreamachine have been realized; in Europe, it's possible to find 78 rpm turntables and to make the dreamachine for a cheap price.

We have not started a commercial formula, mainly because we concentrate our energy on creation; in this domain, we can do without money and the transactions are limited as far as I am concerned to the domain name and web space of Interzone.org.

Everybody has his own equipment , related to his own interests and activities, and puts it to the group disposal for free. Hence Interzone does not require from its member any expense, and every member is autonomous.

In this frame, money is not useful and we do not need more than the one we respectively own. Our main motivation is pleasure we get from being part of the group. We have no obligation in it, except the ones we decide for ourselves, no obligation about time, everybody does what he can when he can; though the coordination works perfectly : see the two musical compilations done : [Music for Dreamachine and Interzone Compilation 1](#)

Another point : this was not programmed, nor is directed from the top : I just transmit information and realize my own creations in function of my means.

As far as the work realized by members in several domains, we might open a shop to put them directly at public disposal.

The fact is that I had to devote a big part of my time to formal work, which does not allow to put up something else.

Our aim is not to make a big production, but to produce in function of our needs : under this aspect, our production looks more like artisan one. For instance for the comic "[Le Taxidermiste](#)" , a first print of 25 copies was done in 2000, then a second one in 2001, and I am printing some 5 more to put in bookshops and for demonstration. The demands were more important than the issues, and we know that if we make it again, we are sure to sell the printed copies. So we can make them in function of our needs through time, without investing any money in advance.

Anyway the example of the comix is not a good one as it does not pay. We started the experiment because the opportunity occurred : José Altimiras was ok to work with us, because he liked the Zone's spirit. This seemed to me practically possible and I wanted to see if we could make it. Now we can make it, but for us to earn any money on the comics would require less expensive devices than industrial photocopy or individual printing, which are too dear. Though we have not lost any money in the deal, as all the copies have been sold.

As far as writing is concerned, we have the complete control of the books, and of their look as well, we can include illustrations of the group and can distribute them to whom we want, when we want. If people want to buy them, they can join us through internet.

Since this month, the use of a translator (Softissimo) puts the French books to English speaking readers' disposal.

As we use only our own creations, we are no copyright fees to pay.

## **B. Proposition of a community structure at the scale of Interzone:**

Interzone is a human group composed of people spread on the whole planet, belonging to different countries, cultures and civilizations, who exchange and create together at different levels since now 4 years. We want to actualize on the physical plan the virtual community we art part of.

### **Type of structure :**

- Similar to the structure of human organism and living world, based upon :

- \* thermodynamic and informational openness

- \* non competition, complementarity, interdisciplinarity (Henri Laborit)

=> this structure is common to the set of the members of the group, in spite of their differences.

- Johnson Family (William Burroughs)

- Community :

If we consider the models of social structures who crossed the ages without collapsing, an effective model seems to be the religious communities, which are still the same through centuries. It allows them to be self sufficient, and to put up life places. It would be interesting to ask some about their rules of management.

Anyway, we got to be aware of not putting up an institutional economical system, as the only reason for a system to be is to produce for the human set which adopts it, a more satisfying way to live, to make life easier. If the results do not reveal themselves satisfying, then the system has to be adapted to individuals.

Our economical systems are human creations, human tools. We elaborate them, they have no existence out of ourselves, nor value above us. We are the only justification of their existence; they are here to serve us, not to enslave us.

### **Aims:**

- Gathering point for the members of the group
- Community experiment, self managed and self sufficient place,
- Place for sale our artistic products directly to the public.
- Place for exhibitions, concerts, public lectures : creation of a Burroughs-Gysin museum with dreamachines, paintings, books, etc.),
- Academies : units of interdisciplinary centres of teaching and research.

### **The place:**

We have several possibilities : we are not obliged to choose a definitive one, we can start by an easy one, which allows to start working. If after a given period (6 months/1 year) we want to go on and can make it financially, then we can go to the higher step.

- Different possibilities:

- \* rent : the rent is shared, at the start, by the people who live in it and the members who are volunteers to be part of the experiment, then by the incomes from the place,

- \* it is also possible to make an association and pay the rent with the subscription fees at the start,

\* to buy : through a subscription in the frame of the Zone, which is possible to buy a house : if 100 people give 750 € (660 \$) we can buy a house worth 75 000 (66 000\$).

- An abbey, a monastery, or an old castle would be ideal. But then we would have to find with the owners a different formula than classical buying or location, which would not be affordable for such buildings, and give ourselves a legal status.

We can start with a small number of the present volunteers in a house we rent in common, then see afterwards: as long as the project is not started, people hesitate to get involved. But once it will be created, more will probably join.

- Other possibility : see about opening a café with beer sellers who would pay a part of the rent.

Presently, here are some opportunities:

- inn Belgium : for sale (162 500 € , 145 000 \$) or rent a building with a house, two shops and a big workroom, in a well situated area. But the place has to be fixed. I can eventually join beer sellers if you think the place is worthy of interest.

- in France in the Poitou, a house in the countryside, with an hectare of land around, which contains a house for 3 people, and independent flat for 2 people, with 3 barns which can be fixed. Ideal as a rest place, situated in a retired village. There are many countryside houses for sale in France.

- a correspondent writes about an empty monastery in the Maine et Loire, the abbey of St Maure previously occupied by Benedictine monks, empty since 7 years, and presently belonging to the regional counsel. It's possible to joint them and make a proposition.

- I got in touch in Belgium with Jesuits about empty buildings which they do not use and we could rent.

### **Self sufficiency for food in the hypothesis of a place in the countryside :**

Production of food: fruits, vegetables, eggs, and buying just what we do not produce : milk, cheeses, meat) directly to the local producers => cheaper food and better quality than industrial food.

### **Earning the money for the commune:**

a) No personal money:

- At the start, we have :

- \* our own resources,
- \* our own means,
- \* our own potential and abilities

On this base, we should be able to feed ourselves if we put at people's disposal things they will like, which answer their expectation or takes in account actual needs which are not presently fulfilled.

- To protect our backgrounds :

In the case after sometimes some members would not be satisfied with the experiment and would want to leave, if the economical results do not fit the expectations and the experiment could not be liveable, it's important that everybody keeps his own financial resources. This to avoid the risks of financial parasitism from the structure to the members.

-In theory, the aim of such a place is to live from it. Practically, if it does not work, we can have a formal job as well.

b) Limiting the benefits to the needs of the commune:

No use of earning more money than what we need : the use of earning money is to get the necessary goods we cannot produce ourselves. If we earn more, we can invest it in the building, necessary equipment or be used to the creation of new academies. This allows to limit "alimentary" work to the minimum, so to use maximum time in creation and quality of life.

c) Choosing activities which bring money in function of :

- our human and material resources, abilities and potential,
- the needs of the population around.

=> \* sale of our artistic productions : self made books, CD, videos, illustrations : direct sale to the public, from the producer to the user, without any go-between.

\* a cyber-café with a free ADSL internet connection and projection of the videos of the Zone,

\* concerts, exhibitions, conferences,

\* academy (unit of teaching and research, lectures)

\* lodging

For broke travellers, free lodging and food in exchange of participation to the work.

---

## V. January 2004 : The Academy 23

### January 2002-january 2004:

Two years after the formulation of a non-Aristotelian economy (see <http://www.geocities.com/interzonelibrary/gsmoney4.html>), here is what has been realized since :

I left Belgium, where I was staying since July 2000, to go back to France in November 2002. When I arrived, I rented an empty hotel as a house to use the place for the centre of teaching I was planning to put up. But due to the disastrous state of the building (problems with the heater, the electricity, water leaks, asbestos, etc., which were not detectable before living in the place) I left four months later to rent a conventional and comfortable house. Anyway, the location of the hotel allowed to receive several Zoners, and led to interesting [creepy pictures](#).

In August 2003, I created an enterprise in the frame of which I settled as a psychotherapist and put up a centre of teaching and research in general semantics, the Academy 23, <http://www.geocities.com/academie23/>. This official frame is opened enough to integrate the sale of Interzone books and creations, organize meetings, etc. We now have the necessary legal frame to realize what we wanted to do. As far as hosting and restaurant are concerned, they are available in the village.

This has been made possible thanks to a help of the state I could get after a three months job I took at my arrival; advises from ANPE before the creation of the enterprise, then a help to create it (ACRE) which maintains during one year the social advantages I had before and suppresses a number of expenses linked to the creation of the enterprise. I also used a workshop of management I made in Poitiers in 1999 and the help I had got from the municipality for the financial aspect.

This context made this new status makable on the financial plan, allowing to work at the different steps the ones after the other, to concentrate not as much on productivity as on the quality of the contents.

Concerning our previsions made two years ago (see <http://www.geocities.com/interzonelibrary/gsmoneyfrench4.html>), some were fulfilled, some not, and some happened differently from the expectations.

About the Taxidermist and the dreamachines :

- I am printing copies of the [Taxidermiste](#) on request, as there are not enough to make serial printings. As all the books are ready to print, it only takes the time of the printing. I am going to use a black and white laser printing, less expensive than the HP Deskjet I used until now.

I am using the same process for my books : printing them on request allows a complete freedom on the contents, which can be updated when necessary and does not request investments.

The English translation is being checked at the moment by

- for the [dreamachine](#), I made new plans for a 45 rpm turntable, as the 78 rpm are now impossible to find. Due to the electric differences between France and other countries, I adapted the plans to the turntable of the Sony PS-LX250H, which is available everywhere and which amateurs of dreamachines can get directly in their own county. So this avoids to get a transformer. I only sell the cylinders and supports. The available models exist in painted and illustrated, with illustrations of Interzone painters : I realized one with a painting by [Kenji Siratori](#), one can see at <http://www.geocities.com/academie23/ondesalpha.html>

Le catalogue 2004 now is on line at : <http://www.inter-zone.org/catal1.html>

Among the **sites**, some new ones were created :

\* [Interzone Library](#) which contains the integral versions of the books on line. They are available in printed version in in the CD, the literary compilation "Come to Free the Words".

\* "Agence de Presse Interzone" renamed "[Rédacteurs Reporters d'Interzone](#)" which contains articles, reports, cut-ups, and other rubrics linked to journalism. The site allows to put articles on line, and get in touch with media interested to buy them, on contractual bases, clear and defined since the start. <http://www.geocities.com/clemsnide23/order.html>

- [Academie 23](#) and the yahoo clubs :

- "Psyber café" : <http://groups.yahoo.com/group/psybercafe/> : group of on line consulting and exchange for professionals of psychiatry.

- Société Francophone de Sémantique Générale: <http://groups.yahoo.com/group/sfsg/>

- Academie 23 <http://groups.yahoo.com/group/sfsg/>

Concerning the **formulation of a non-Aristotelian economy**, here are the latest element completing the previous pages :

It rests on :

1) Taking in account the actual resources and means of the individuals, on the material and human plans, independently of the fact they are not taken in consideration in the present economical system;

2) and putting those resources in common : mathematically, due to the principle of non-additivity, the result is higher than the sum of the parts :  $1+1=3$ .

From there, the result increases exponentially with the number of people who function in this system, which happened with Interzone.

The set of people finds itself then with a sum of resources and potentials which belongs to it, exists nowhere else, are not pre-visible at the start as nobody directs the set, and people get involved in function of factors nobody can control. The elements then can get organized together independently of the economic context, on the base of what they can do and feel like doing, and of reality as it presents itself, not limited to a pre-recorded vision of it : the territory is larger than the image we had from it before => we can use of some parts of the ground which were not taken in account before.

In other words, it is not any more an economy based upon symbolic values, the value of which does not rest on the symbols themselves but on the nervous structure of the people who attribute it. It is an extentional economy, which rests on the facts: start from actual human needs, and how to fulfil them, use the effective resources: human resources and the ones of the context, building from what we have, in using the unexplored and neglected resources and potentials, knowing that at the end we get much more that we individually had at the start.

In this frame, the experience proves that one does not need money : everybody uses his own tools, no more expense. I coordinate the group with very few money, my incomes being limited to some short time jobs and minimum revenue during the latest years.

3) The other postulate of this economy is that individual enrichment is linked to the one of the set : the question here is not to take the money from someone else's pocket, the result of which is at the end an institutionalized pillage leading to the ruin of economy. The question is neither to compete with the official economy, nor to put up an alternative political force, but to integrate this change of relation in the economy, stating from the individual level, and to lead to a change of relations with



the upper levels in the frame of present economy. This mutation also is their interest : the present way based upon institutionalized pillage leads to long term to exhausting of resources and to the ruin of economy : the change in the relations allows the richest ones to make money through a multiplication of the resources, not any more at the prejudice of the poorest ones, but to their benefit. In other words, everybody wins.

The impulse does not go any more from the top to the bottom of the pyramid, but from the bottom, who impels the change, to the top. As Henri Laborit said : "The aim is not to take power from the ones who get it, it is to generalize power." (La Nouvelle Grille")

On the biological level, it consists in restructuring our human affairs, here economy, on the structure of our organism (relations of non-competition, complementarity, interdisciplinarity, thermodynamic and informational openness). The similarity of structure between the different levels allows then to solve oppositions induced by the previous non similarities of structures induced by Aristotelian and Cartesian logics, and represents a predictable and efficient frame allowing to get satisfying results to the individual, local, national and international levels.

The aim is not to get out of the frame of liberalism, but to adopt, inside this frame, rules and ways to function it potentially includes, but which have not been experimented until now, due to the conceptual limits and mechanisms of thought by opposition to which our civilisation has remained stuck since 2500 years, and [which have prevented us to handle symbols correctly](#).

The same goes for globalization : only a free economy, at international scale, can fit an international group as Interzone, the members of which are spread all over the world, and constitute an alternative to the national legislations, all different, and making impossible to apply international transactions at the scale of several countries, except in fiscal paradises.

So the aim here is not to put up a system, opposed to the previous one, and competing with it, but to integrate to it in substituting clear and fair rules to rigged rules, and proposing a frame which can integrate it and adopt it as well. On the political level, it just fits with the application, in economy, of the model of relation of the articles of the International Declaration of Human Rights : an economy compatible with democracy.

I know that this can seem idealist at first sight, but what I am saying here rests :

1. On a mathematical demonstration,
2. on the confrontation of the hypothesis to the facts in the frame of a given human group,
3. On the application in the frame of this group, of a set of concepts appeared in the frame of scientific evolution of the XXth century.

Some people argue that the present liberal economy is not based upon an ideology, but on greed. I am not talking here in terms of moral, nor judging anybody. Now let's examine this sentence : "Liberalism rests on greed" : where do we go from this ? First that greed is not the monopoly of liberalism : if we observe what happens in so called socialist regimes, the greed does not disappear : the money only goes from the ones of the rightists to the hands of the leftists, who then settle another system of hierarchy which leads to other inequalities. There is not on one side "the greedy liberals" and on the other side "the "social generous ones", or whoever. The ideologies are different, but the mechanisms of thinking and behaviour are similar.

Now let's take the example of a greedy kid : if you are a greedy child and if your greed leads to harmful consequences for you, then you will get those consequences. You will eat too much cake and be sick the next day. Then you understand that if you do not want to be sick, next time you will not eat too much cake. You understand that the interdiction "do not eat too much cake" is not a question of moral, that the point is not that "greed is bad", but that the point is that greed leads to

harmful consequences for you. It makes you sick. So not eating too much cake is not "good" on a moral point of view, it is what Korzybski calls "[selfish wisdom](#)" :you do not think nor act anymore in terms of values "good" nor "bad" in a given system of evaluation, in contradiction with other systems of evaluation, but in function of the consequences of your acts in the actual facts, for you and the others. You get out of a logic of guilt to get into a [logic of responsibility](#).

The step here is not [intensionnal](#) : it is not an abstract theory which I would try to apply to the economy of the group, but of the inverse step : the practice started to exist before the theory , before we started to think in terms of economy, as we first started to experiment Burroughsian concepts. It is the way of relation we spontaneously adopted on the base of those concepts ([Johnson Family, third mind](#) , [experiment of non aristotelian functions of writing](#) ) and the aims we followed in the frame of the group ([to create our reality](#) which led to this practice., then the practice let to the analysis of what was going on in terms of general semantics (which Burroughs also had studied and which he used in his writing) then to the formulation of a non -A economy, and the creation of an enterprise which aim is to function on these bases.(2002-2004).

The process happened in the following order : experiment of Burroughsian concepts => Johnson Family structure of relation => common aims => practice => theory based upon the practice.

The step adopted here is [extensional](#), based upon the facts and adapted to them.

With the distance of time, it is funny enough to see this experiment realized by the heirs of the grandson of the inventor of the adding machine. :-)

(About the notions of general semantics used here, see the documents at the department of general semantics in [Interzone Academy](#) and for more information, the [Académie 23](#))

Isabelle BAUDRON-AUBERT January 4th 2004

---

## VI. January 2006 : A non-Aristotelian globalization ?

Here is an idea in the frame of the research on a non-Aristotelian economy, based upon general semantics, which has been started in the framed of the Zone since some years (see <http://www.geocities.com/Athens/Crete/9445/economy.html> ).

### a) Definitions :

First, what do I mean by non-A economy ? One can understand it comparatively to **an Aristotelian economy**. **An Aristotelian economy rests on Aristotle's logic : principle of identity, of contradiction and of third excluded.**(See the details in the article "[Les différentes étapes de l'évolution de l'Occident : Aristote, Descartes, Korzybski : trois visions de l'homme et du monde](http://www.geocities.com/interzonelibrary/dptsg1ADK.html)"<http://www.geocities.com/interzonelibrary/dptsg1ADK.html> ). This system has shaped the vision of the world and the relations between humans since more than 2000 years.

It rests on the following postulates:

- **the belief in the value of money as something real, in economical rules gifted with a real existence, independant on its users,**
- **the postulate according which the only way to get money would be to take it from somebody else,**
- **a structure of relations based upon exclusion,**
- **relations of competition, of conflict, between included and excluded, the rich and the poor,**
- **a strategy based upon intelligence of strength relations to get money.**

This system rests on parasitism, on the plundering of the resources, and consists in sawing the branch on which one sits: once the resources have run out, there is no resource left and the system collapses.

So comparatively, a non-A economy is based upon :

- **a concept of money as "a symbol of exchange between humans, the value of which rests on a common agreement between its users" (Alfred Korzybski: see Science and Sanity: "[On symbolism](#)")**
- **the postulate according to which it is possible to earn money without taking it from somebody else,**
- **a structure of relations based upon inclusion of all the elements in the same set ("A structure is the set of the relations between the elements of a same set" (Henri Laborit: "La Nouvelle Grille"))**
- **relations of non competition, complementarity, interdisciplinarity and informational openness, similar to the structure of living species (Henri Laborit), leading to a higher result than the sum of the parts ( $1 + 1 > 2$ , [mathematical principal of non-additivity](#), applied to writing by W. Burroughs and Brion Gysin as "the Third mind")**
- **a strategy based upon strength of intelligence relations,**
- **enrichment of ALL the partners.**

## **b) Simulations :**

Here are now two imaginary simulations between some partners of different countries :

Mr X Singh in India is a merchant of crafts. He sells mural paintings for 4 € each. The usual way of dealing is that I, in France, buy him one for 4 € which I sell here in France for 40 €. So I am getting, once the mail fees are taken out (5 €) :  $40 - (4+5) = 31$  € for each. So when Mr X Singh earns 4 €, I earn 31.

Now here are some non-A ways we might proceed:

If we consider such an exchange in the frame of globalization, there are, lets say to make it short and simple, "rich countries" where one can earn 31 € for a given product, and "poor countries" where one gets 4 € for the same product. The prices are adapted to the level of life in the different countries. But in this frame of globalization, these difference of levels of life induce relations of dependency and strength, and all kind of conflicts between the poor and rich ones.

So the point is to find a way allowing to get rid of those sources of conflicts, which are not only economical, but involve the whole Aristotelian system and postulates which still shape our vision of the world and condition the relations between humans. The frame of Interzone seems favourable as it is an example of an international group in which all the elements are included, without any consideration for the usual barriers which are used to exclude people in the Aristotelian world.

### Example 1 :

Instead of buying Mr Singh each painting 4 €, I am going to propose him to give him  $4 + 5 = 9$  €. So he will get 5 € more than he usually gets , at the condition that he gives 2 € to somebody who has no money. So he ends to sell his painting 7 € instead of 4 €.

Of course, I get less money than the usual trade ( $31 - 5 = 26$  €) but as my Indian partner gets more than with the other buyers, he is interested in keeping me as a client, so I can buy him more, and sell more, so I get more money this way. The person who originally had 0 € gets 2 €; with this, he can eat when he could not buy anything with 0 €. He can also make a product which costs 2 € in India, and, if I buy it from him, I can sell for 20 € in France. So, using the same system as with Mr X Sing, I am going to buy him  $(2 + 5) = 7$  €, at the condition he gives 2 € to somebody else who has 0 €. Etc....

### Example 2 :

I buy Mr X Singh a painting which costs 4 €, which I sell 40 €. Taken out the mail fees, I get 31 €. So my benefit here is 31 €, when Mr Singh's one is 4 €. We can add both benefits ( $31 + 4 = 35$ ) and share it in 2 : 12,5 €. So each of us earns 12,5 €.

Even this way, I earn on the product  $12,5 - 4 = 8,5$  €, which remains twice more than my original investment. So I earn 200 % on it, which is financially correct. Mr Singh earns 8,5 € more than he would have earned the usual way, which is 300 %. So he gives 4 € to somebody else who has 0 euro, and who now gets 4. I suppose one can imagine a hundred of examples based upon the same principle.

On these bases, relations of exclusion and conflict have no reason to be, as all the partners have interest in being part of the deal, and to be partners with each other. This system does not create poverty, it creates wealth for everyone. The example here can be applied the same way between other countries, and not only at the international level, but also national. It might allow us to get out of the logic of opposition between the rich and poor, and escape the different ideologies which perpetuate conflicts between citizens of a same country.

**c) Inferences at higher levels :**

Considered at individual level, this system may appear as naïve and cute. But considered in the frame of future international economical relations with Eastern Asia in the frame of globalization, it might allow us to get out of the actual economical logic which is going to go on at our detriment. In other words, it might allow us to invert the impulse.

Applied in the frame of national economies, it might allow us to get out of a logic generating conflicts between the rich and poor, and to the ideologies which come from it, rightist as leftist, which perpetuate conflicts between citizens of a same country. What do you guys think about this so far ? Any feed-back welcome (forum of the site "La sémantique générale pour tous": <http://semantiquegenerale.free.fr/forum/> )

Isabelle AUBERT-BAUDRON January 4th 2006

---

## VII. January 2009: Interzone Editions: experiment of a non-aristotelian economy January 14<sup>th</sup> 2009

### Interzone Editions

The main event of the year 2008 has been the creation of [Interzone Editions](http://www.interzoneeditions.net) <http://www.interzoneeditions.net> , which started to publish officially books on which we worked in Interzone since a number of years.

Five books are now available :

1. the French translation of the « Seminar of General semantics 1937 » by d'Alfred Korzybski <http://www.interzoneeditions.net/korzybski.htm> , which I translated in the nineties. The translation has been reread by Laura Bertone , from the [Institute of General Semantics](http://www.instituteofgeneralsemantics.org)

It is the first book by Korzybski published in integral version in France. Exgtracts from different books have been published at the [Editions de l'Eclat](http://www.editionsdeleclat.com) : "[Une carte n'est pas le territoire](http://www.editionsdeleclat.com/une-carte-nest-pas-le-territoire)". It contains the notes of courses given at Olivet College. It is available in English at the [Institute of General Semantics](http://www.instituteofgeneralsemantics.org) [www.generalsemantics.org/index.php/shop/books/booksbya.html](http://www.generalsemantics.org/index.php/shop/books/booksbya.html)

2. the comix by José Altimiras and François Darnaudet "[Le Taxidermiste](http://www.le-taxidermiste.com)" et its English translation, "[The Taxidermist](http://www.the-taxidermist.com)", which I translated. It has been revised by Ken Gage.

3. the Christmas tale "Stella Matutina" , in [French version](http://www.french-version.com) the original one , and [English version](http://www.english-version.com) , translated by me and revised by Paul O'Donovan. .

The next book to come is "[Le Temps des Naguals : autour de Burroughs et Gysin](http://www.le-temps-des-naguals.com)", a compilation of interviews, articles, documents on Burroughs and Gysin, containing original photos and illustrations by Paul O'Donovan and other Zoners.

### Self production:

Interzone Editions is the result of several challenges : the first one was, when we started [Interzone creation](http://www.inter-zone.org/menu.html) <http://www.inter-zone.org/menu.html> : are we able to produce our work as artists and writers ? We tried and realized it was possible at our scale with the only technology of computers and internet, and that it was much cheaper and much more simple than going through the commercial way. Music compilations were done, and writers published their books : see the [catalogue](http://www.inter-zone.org/catal1.html) at <http://www.inter-zone.org/catal1.html> :

Books: <http://www.inter-zone.org/catalbooks.html>

Music : <http://www.inter-zone.org/catalcddvd.html>

Illustrations, paintings : <http://www.inter-zone.org/catalim.html> , <http://www.inter-zone.org/gal.html> and <http://interzone.galleries.googlepages.com/>

Video: <http://www.inter-zone.org/catalvideo.html>

## An economy adapted to the Zone : a non-Aristotelian economy :

The second challenge was : which rules of economy shall we use, knowing that the rules of formal economy do not fit to the group, because their respective structures were not similar. So we had to redefine other rules which would fit to the spirit of the network, otherwise the economic level would have altered it, and it would have become impossible to function as Interzone any more.

So we started to think about it and made several different attempts. I reformulated new rules based upon Korzybski's general semantics on [symbolism and function of money](#), and came to a non-Aristotelian economy : see the articles in Interzone Academy at <http://www.geocities.com/Athens/Crete/9445/economy.html> and which I have gathered in the page of the site "[La sémantique générale pour tous](#)" in the part dedicated to economy : [A non-Aristotelian economy](#) at <http://semantiquegenerale.free.fr/ecorestruct.htm>

So [Interzone Editions](#) is the result of the experiment of those data. As a result :

- I handle all the levels of creation of the books : from the start of the writing and translating for my own work, then official registration through the ISBN number and number of dépôt légal, to the printing itself and sale through the internet, without any intermediary.
- The artisanal printing allows a complete freedom concerning the contents and design, and makes possible a presentation, look and insertion of photos, documents and colour illustrations more creative than with formal edition.
- I print the books on request, and send them once I have received the money from the buyer, so I do not have to invest money nor risk to loose any.
- I do not need anything accept my computer and printer, which I have had before, so this does not require any special expense, and the price of the printing costs me the prince of paper, ink, and a bit of glue.
- This way the price I get for my own books is higher that the fees which a formal publisher would give me for the writing itself. Concerning the other authors (the Taxidermist), we share the benefits of the book in three equal parts, which is 20 % of the price of the book. From my side it is not much, but what I get from my own books makes the balance. Proceeding this way , I could not sell through bookshops because the books are printed by unit, but the aim here is not to sell thousands of books, but just to get the money I need, which is the most important. In case I'd get more requests than I could handle, then I'd consider have series of books printed by a professional printer, but then I'd be sure to earn more than I'd invest, which is not the case presently.

## A use of writing according to its original fonctions:

Beyond the technical sides of printing and selling, the other bet is to use writing according to its original functions :

1. Symbolic function of language (Korzybski): a word is a symbol, a sign which stands for something and so writing must represent as accurately as possible the facts and events it stands for, otherwise the level of the words is not similar to the facts, the map is not similar to the territory it represents.

2. Function of time-binding (Korzybski) : writing binds the author and writers through time-space : when I read a text, I am in touch with it's author at the moment and in the place he was when he wrote it.

3. Magic function, described and experimented by Brion Gysin and William Burroughs : "Writing is about making it happen" (Brion Gysin) : "Mektoub, it's written" : a writer writes a scenario of reality which his readers then can actualize in their own life, and create their reality.

4. Through the bind it creates between the author and the reader, writing settles a collaboration between them, which produces, in function of the principle of non-additivity in mathematics, a phenomenon called by BURROUGHS and GYSIN the "Third Mind " : "*Gysin: when you associate two minds / Burroughs: There is always a third mind / Gysin : A third higher mind .../ Burroughs: Like an invisible collaborator.*" ( "The Third Mind" ). The whole is bigger than the sum of the parts. As far as human cooperation is concerned,  $1 + 1 = 3$ .

One of the aims of Interzone Edition consists in making people more aware of those functions, the knowledge of which remains limited to Burroughs' and Korzybski's readers, and able to apply them practically.

---



# Non ordinary levels of reality

## The Roots

Jim Ward-Nichols

"I AM Jala\*AN." (jlwn111) wrote @ 2009-10-11 05:30:00

Mood: Grateful

Music: Howard 100 (SIRIUS XM Ch. 100)

I'm going back to My Roots on this one. The roots of my paranormal experience on this planet. My 111 Roots. Yes, my mind-boggling nearly life-long connection to/with the number 111 is really at the heart of nearly everything I have ever experienced in the Paranormal Arena.

It's been the trigger.

Admittedly, I've always been a sci-fi fan (since my dad took me to see one of the "Planet of the Apes" movies when I was 6!) and perhaps this has always kept my mind open to All Things Paranormal. But still. From the very moment my voice was slapped onto [that Scotch 111 Magnetic Tape](#) in 1965 to the very last time a "funny" large-scale coincidence occurred with 111 --- I'm calling the whole darn thing - soup to nuts - A MIRACLE. There, I said it. It's a MIRACLE.

In the write-up, for many years, I've said the following regarding 111: "it is a divine yet not completely understood gift." Kinda hedging on the whole MIRACLE thing so I didn't sound completely wacky. I said "divine" and "not completely understood" back then but really, let's face it people:

[It's a freakin' miracle.](#)

And you don't really need to understand a miracle or how it happens. It's just a miracle. You experience it. It happens. The fact that 111 came into my life at such an early age (3) and the fact that it gradually revealed itself over the course of the past 44+ years and the fact that it eventually led to my ongoing (and very private) experience with the Qabala --- well, it's completely amazing. The fact that 111 and 7 are joined at the hip (111 is the binary representation of 7) is also completely amazing.

I mean, let's face it folks, SEVEN is a Big Deal Number here on Earth. Think about how often it comes up. Not just in the Christian's bible, not just in our planetary history, but in nature as well. The fact that 111 and 7 are linked wasn't something I realized until WAY after it came into my life. I

was too busy trying to keep up with all the sightings. Again, that's all ancient history at this point. And most of you should know by now that there are very few occurrences of 111 nowadays that impress me.

So... if you're wondering how I really feel about my "completed" experience with 111, I'll tell you in plain English (and this replaces any "hedging"-type statements I made in the final update to the write-up on 11/01/2000) ---

111 forever remains a truly Magickal Symbol that represents All Trinities. It will forever have close ties to Lucky 7. It led me to my sacred journey with the Qabala. And it was revealed to me THROUGH DIVINE INTERVENTION on a journey that began at the tender age of 3 (you know, III).

There you have it. Now... when I say Divine Intervention exactly what do I mean?

Do I mean God? Maybe.

Do I mean Aliens? Could be.

Like how the image of [Devils Tower](#) (no apostrophe) was implanted in people's minds as a means of COMMUNICATION? Wouldn't rule it out.

Do I mean my dead Grandfather who, as an extra-dimensional spirit-being, was trying to sway me in the direction of Christianity by imprinting a blatantly Holy Trinity-like symbol in my brain? It's certainly possible.

And how, to respond to my critics (you know who you are), do you positively rule out some form of Mental Disorder being at play here? Like, somehow, I'm insane because I've come to see 111 as a Magickal Symbol? And I'm insane because I feel that it was GIVEN to me through some Supernatural chain of events that involves the creator of the universe, Aliens, and/or my dead Grandfather? You can call me insane. And you probably will. And based on society's norms, I probably am. But really: that matters little (to me, at least, and to those who believe in my journey). If you read the write-up from start to finish, it's very clear that I did not go looking for 111. It found me. In 1980. And then, as was revealed several years later, it turned out that I had already been branded by 111 in 1965 when my Grandfather slapped my voice onto [that magnetic tape](#). And if you've done even the most basic investigations into the Qabala, you know (for a fact) that 111 has its most ancient roots in that system. The conclusion that I draw from all this, of course, is that this stuff is real. And how I came to be connected with it is A MIRACLE.

Most who know me from my childhood probably hoped that this miracle deal with 111 would have led me straight to Christianity and its Father, Son, and Holy Ghost. Its Holy Trinity. The TRI-unity Godhead that, for some Christians, is at the heart of their faith. I recognized this connection very early on (the summer of 1980, actually). But since I saw The Trinity coming up in religions that predated Christianity, it was very hard for me to ignore those faiths and commit to the Christian Faith. Couldn't do it. Still can't. For the very same reasons. I felt more of a connection to the Celtic Systems and their heavy reliance on Trinities than I did to the Christian Faith. Did my refusal to see 111 as a Christian-style miracle lock me into some kind of Anti-Christian (potentially "evil" and/or "dark") system of influence? I don't think it did. It locked me into a life-long journey with the Qabala is what it did. Certainly a far cry from anything even remotely "evil" or "dark" (in my book, at least).

Does 111, in fact, defy the traditional good/evil dualistic characterizations that run rampant on this planet? I believe it does.

But negative/dark/bad/evil characterizations of 111 do exist. That cannot be helped. I speak about this in the [write-up](#). Go back and review them if you need a refresher course. Some have actually had what I would call very ominous “first thoughts” about what it really was. For instance, many moons ago, I heard this from someone:

It is the time that emits the least amount of light on a digital clock (it was an old LED-style digital clock, of course, not an LCD clock that has ALL Dark Numbers).

### **111. THE LEAST AMOUNT OF LIGHT. Huh!**

Let's think about his statement. Aside from the LED-style digital clock being turned off, it really is the time that emits the least amount of light. Of course that brings in the Light/Good and Dark/Bad duality vibe that so many of us are stuck on. So whether I liked it or not, there you had 111 (III) being tied to Darkness (lack of light).

So... where does that leave us?

111... magickal DIVINE gift... Aliens... Dead People (extra-dimensional spirit-beings)... the least amount of light... "dark as hell"... where is this all leading?

Let's face it: most of us, on a near-daily basis, feed the Dualistic notions of Light/Good and Dark/Bad with our thoughts, words, and deeds. I'm here to tell you that these associations are false. You're saying "well duh, Jim, of course they're false." YOU'RE SAYING THAT. But guess what? The vast majority of humans on this planet are not. What about DARKNESS. Is it bad? Is it good? Is it neither?

I think that you should first accept the fact that we've got billions of people thinking that Light Means Good and Dark Means Bad. That's just a fact of life on this planet. What does that do to the psychic landscape? Well, it sets up a pretty hefty planet-wide "Thought-form Wave Function" that generally eclipses our attempts to block it. So what can we do about that? As I see it, we have three choices:

1) Work to convince people that "The Light" isn't necessarily "The Good" through some form of Crusade.

or

2) Work to convince people that "The Dark" isn't necessarily "The Bad" through some form of Crusade.

or

3) Totally ignore Earth's prevailing and oppressive "Thought-form Wave Functions" by congregating with other like-minded, non-Dualistic individuals. By creating comfy little cocoons in hidden, more remote sections of the Planet. By living a life that's free from Duality's influence. By experiencing the continued Magick of the Divine Gifts we're lucky enough to acquire during the journey. And (just for the heck of it) by making ourselves as open as possible to physical and

spiritual connections and info-sharing with ALL Extra-Terrestrial and ALL Extra-Dimensional life-forms that might happen to come our way.

I'm choosing 3 (III). For obvious reasons.

How 'bout YOU?

1by1as1,

\*ME\* [aka J'lahn, aka JAHLON, aka Jala\*AN]

LocalSuperCluster, [UNI-1]

<http://www.the111experience.org>

<http://www.triple1.org>

---

## [\*\*the 111 experience of J'lahn \[Version 53.112\]\*\*](#)

Copyright [Jim Ward-Nichols](#) 1989-2012 - All Rights Reserved

*My connections to/with 111 & 11:11 began in the mid-1960s. The material found below details these connections.*

*The Final Revision to "the 111 experience" (the chronology) was published on 11-1-2000. Links That Matter & Other Items of Interest are updated on an as-needed basis.*

*Last revised: **January 11, 2009***

*Beyond the Chronology - additional material published after 11-1-2000:*

[The 911 Tragedy: My 1:11 NYC Skyline Is Gone \[END 111\]](#) (added September 19, 2001)

[the Three Keys of Jala\\*AN - Part ONE \[V16.2\]](#) (updated January 11, 2007)

[Beyond the II\\_III\\_II SHADOW PUPPETS \[V1.1\]](#) (added July 11, 2004)

[ALL\\_ELEVEN \(||||\\_|||\\_||||\) & Other Recent Visions](#) (added August 1, 2004)

[the 11:11 Cipher of Patient ZERO \[V5.1\]](#) (updated November 3, 2004)

[CipherClues - The True Meaning of 11:11](#) (updated December 21, 2007)

[Happy Earth Day 2005](#) (updated April 21, 2007)

[Our Alien Ancestry](#) (added June 28, 2005)

[Under the Three Keys Hood - Part I](#) (added June 28, 2005)

[Under the Three Keys Hood - Part IIa](#) (added June 28, 2005)

[Under the Three Keys Hood - Part IIb](#) (added June 28, 2005)

[Halliday and Resnick FINALLY Say "Curiously"](#) (added June 28, 2005)

[Why Shadow Puppets?](#) (added June 28, 2005)

[For 1/11: Essential Artifacts](#) (added January 11, 2006)

[End\\_111 & The New Freedoms](#) (added April 7, 2006)

[666 - The Number's Pre-Rev. 13:18 Roots](#) (added October 1, 2006)

[Time is Three Eyes & Eight Elbows](#) (added October 1, 2006)

[The Roots Go Deep](#) (updated September 21, 2007)

[An Update on THE CLEARING](#) (added November 21, 2006)

[The Ancient LiveJournal Blog Archive Bonus!](#) (added January 11, 2009)

### *"the 111 experience" (the chronology)*

This is the chronology of my experiences with the number patterns One Eleven (111) and Eleven-Eleven (11:11). It documents my earliest experiences with 111 (CE 1965) and 11:11 (CE 1968) through 11-1-2000. If there are any questions regarding this work, or if you find your own Special Pattern on the current version of The Big List (11/111/x11/1111/111x, 112, 137, 22/222/2222, 3/33/333, 316, 318, 37, 42/420, 44/44x/444, 47/x47, 53, 55/555, 666, 69, 7/77/777, 13/42, 23/32, 88/888, 1212, 1234, 1432), feel free to contact me through e-mail at [jlwn111@hotmail.com](mailto:jlwn111@hotmail.com).

**BACKGROUND:** WHO IS J'LAHN? J'lahn is a name that came to me during an early summer night in late June, 1988 while I was living in [Boulder, Colorado](#). It was an intense night, a night of heightened energy, and a night of heightened thought. In my dream state I felt that, for some reason, there were two very powerful beings down near Denver and that somehow I was connected to them. I sensed that they were WALKING to Boulder to meet me. The main Highway is a state road called 36. At any rate, in this lucid dream I knew that I needed to start walking to Denver down 36 and that I would meet them somewhere in the middle. So in the dream, I began my trek

down 36. While I was walking, I imagined that we (the three of us) were communicating with each other telepathically. These two beings (they may have been women) referred to me by something that sounded like JAH-LON (I may have told them that this is what they should call me - I don't really remember who used the name first). I awoke from this deep dream state before I actually met the two. From that moment on, I felt that my INNER CORE BEING was, somehow, named J'lahn. I chose the "J apostrophe" spelling because that seemed most fitting. So that's how the name J'lahn became meaningful to me and that's how it came to represent my innermost self - it was all from an incredibly lucid dream I had way back in 1988.

### ***1965 - The Beginning***

When I was three years old, I was recorded singing "Old Macdonald" and "Jesus Loves Me" by my grandfather, [The Rev. L. F. Nichols](#) . The recording was made on a [SCOTCH reel-to-reel magnetic tape](#) (model number 111-12). The flat, reel-to-reel style tape box cover displays a large, white **111** on top of a red and black checkered background. The tapes were discovered in a box of memorabilia during the summer of 1988 while moving from my childhood home.

### ***1968 - The First 11:11 Connection***

I used to draw racing cars all the time when I was a little kid. I think that I started putting numbers on them after an outing to the "Stock Car" races up in Middletown, NY. The drawing you'll see [here](#) is from 1968 when I was just 6 years old and represents the very first evidence of a connection to Two Elevens (known today, of course, as 11:11).

### ***1976 - The Random ID Assignment***

I was assigned an ID number of '011110' in the computer systems of [the newly opened regional high school](#) . I didn't connect this to "**the 111 experience**" until the summer of 1980.

### ***July 29, 1978 - The Last Issue of Tabor Lake's THE COURIER***

I spent every summer of my childhood at a place called Tabor Lake in northern New Jersey. Two of my friends (they were brothers, actually) and I published [THE COURIER](#) , a small "magazine" telling all about the people, places, and things of Tabor Lake. The Last Issue's cover (#11) showed the cover of the "Preview Issue" (#1) with the caption: "OUR FIRST ISSUE - 1974".

### ***1980 through 1983 - The Early 111/11:11 Synchronicities***

In the summer of 1980, I worked at [the local newspaper](#) delivering papers to people who didn't get their papers and carriers that were shorted. I spent a good deal of time in the car and found that I began to see 111 imbedded in the numbers on the odometer and tripometer at least once a day. The first few times it happened, it didn't seem odd, but the problem was that it kept happening. Somehow I would look at the mileage indicators just as they had turned to 111.

I then got a couple of addresses to deliver papers to that had 111 as a part of the address. Now I was starting to get a little spooked. At this point, the experience I was having was very private - I hadn't told a soul. I approached a woman at the newspaper who was into numerology and astrology and asked her what it meant if someone kept seeing the same number all the time. She said "I don't know, but I keep seeing 222 all the time and it's really starting to piss me off !!!"

I thought I was dreaming. How could she be saying this? I hadn't told anyone about my experience until that moment. I said "You're not gonna believe this, but I was going to ask you why I keep seeing 111 all the time!" We were both a little scared by this. The probability that we would both be having such a similar strange experience seemed very low. At that moment, I began to think that I was experiencing something paranormal - something that could not be explained with conventional scientific tools.

The rest of the summer was spent trying to deal with 111 whenever it would come up and trying to remain calm about the whole thing. It showed up in the running time of THE OMEN (111 minutes). This was also when I realized that [my high school ID had 111 embedded in it](#) . I wondered if I was going crazy. I thought that maybe I was experiencing some kind of paranormal premonition. Was I sensing the coming of World War III (World War One-One-One)?

Toward the end of the summer, I had another idea. Was 111 a numeric symbol of the Christian Trinity or Trinities in general? A month before my Grandfather Nichols died, he told me that the next time he saw me he would tell me the secret of how he kept his faith. He died before he told me the secret. Was he giving me a sign from the beyond? I kept seeing [111](#) and continued to resist categorizing it.

The next major event came in September, 1980 during my freshman year of [college](#) . At this point I had begun to share the details of my experience with my closest friends and family. Some of them reported that they started noticing 111 only after I had mentioned it to them. They also reported to me that they started seeing 11:11 on the clock after I brought 111 to their attention. I hadn't been seeing 11:11 but I did find these reports very interesting. I was mostly seeing 111 on digital clocks at this point - meaning that it would be 1:11 or it would turn to 1:11 just as I looked at the clock.

My friends in college (who were all studying to be some kind of scientist or engineer) wanted to help me debunk this. The theory was this: choose ANY number at all, make a mental note of it, and then it will start coming up all over the place. We took my TI-55 calculator and used the random number generator on it to select a random number between 1 and 600. We thought it might give us something that looked like a time. It didn't. We got 37. We thought "37's a prime number, seems odd enough, let's see if it starts to come up." And for me, it did - mostly on cash registers (in prices and change) and in numbers that would come up in my various labs and classes. As a prank, we all helped paint a big 37 on the statue in the middle of campus.

Then one Saturday a few weeks later I was playing around with the numbers in a homework problem and realized that 37 was a close relative of my number.  $37 + 37 + 37 = 111!$  Why should a random number that we generated on a calculator have ANY connection to 111?

Starting in 1982, I began to take special note of several different days during the calendar year. They were January 11th (1-11), November 1st - All Saints' Day (11-1) and [April 21st \(111th day of the year\)](#) . These became my own special holidays. Others who knew about this would actually take the time to say "Happy One Eleven, Jim."

In February 1982 I was with my Grandmother for my yearly trip to Florida. I was at a mall and was looking at a map of the facility. I saw that store number 111 was called Pop-Tops. That sounded interesting. It turned out to be a T-shirt store so I decided I would buy an orange T-shirt with three bright purple ones on it. That night I stood on the beach wearing my new T-shirt and kept repeating the phrase "What is the meaning of 111?" over and over and over. Right after the last time that I asked, a shooting star sailed brilliantly across the clear night sky. A chill ran up my spine. Was I making all this up or was I experiencing something completely paranormal? Was it a symbol for some sort of Trinity?

### ***1987 through 1988 - Boulder and Sedona***

I stopped seeing 111 all the time in late 1983. It had become an integral part of my life at this point (all my close friends and family were aware of my association with the number) but I had stopped seeing it on a regular basis. I had graduated from college and had been working as a data processing professional for three years. I was on vacation in Boulder during the summer of 1987 visiting a friend of mine from college. I immediately fell in love with the town. The most striking thing about Boulder is that [it is right up against the Front Range](#) of the Rocky Mountains. Right there, in plain view of the entire town, were the Flatirons. The Flatirons are a collection of huge slabs that people go climbing and hiking on.

There are three main slabs. The Flatirons seemed like a huge 111 looking out across the town. My friend Marty agreed. He was one of my friends in college who had tried to debunk 111 nearly seven years earlier. We felt that, once again, 111 was staring us right in the face. This was also right around the time of the Harmonic Convergence - that event added another mystical layer to my Summer of '87 vacation.

I had such an intense vacation that I decided to leave New Jersey and move to Boulder for a break from the hectic pace. I spent nine months in Boulder - living, working, and playing. It was very relaxing. In late June of 1988 I moved to [Sedona, Arizona](#). I had never been there before but had heard that many people on spiritual quests were beginning to gather there. I figured that if anyone was seeing the same thing I was, surely they would be in Sedona. I got networked in with the hip crowd in town very quickly through my housemates.

Although everyone found my 111 connection interesting, nobody was having the same experience. I found a book in a town near Sedona, though, that really made quite an impact on me. It was called ["777"](#) by Aleister Crowley. In it, there were several direct references to 111. It referred to 111 as a symbol of the Trinity and the "Trinitarian Equation  $3 = 1$ ". I thought this was a pretty amazing discovery - it was July 1988 about a week after the Fourth of July. I had finally discovered a reference to 111 that pre-dated my own experience with the number.

### ***January 10, 1992 - Finding Out About Solara and the Star-Borne***

Again there was a lull. That lull lasted until January 10th, 1992. That evening I discovered there was a group of people who were going to celebrate 1-11. I thought, "Hey, that's MY day!" They called this event the Eleven Eleven (11:11). That's right - the 11:11! My search eventually led me to an organization called Star-Borne Unlimited and a woman named [Solara](#) who had coordinated this world-wide event. I had foreseen that January 11, 1992 would be extra special many years prior to it actually arriving. I knew that  $19+92 = 111$  and that on January 11, 1992 the date would be (numerologically) 111-111, or 3-3. I also knew that 33 had great meaning to many different branches of Western Mysticism. I thought it was rather interesting that a date I had begun to see as special way back in 1982 (see above) had been chosen by others for an event that took place in 1992.

### ***1994 through 1995 - Continued Revelations***

There is a reference to 111 in Book I of The Lord of the Rings. This was pointed out to me in early 1994. There is a birthday party being held and one of the characters is turning "eleventy-one, 111, a rather curious number..."

Woodstock '94 - For the entire three days of the festival I carried a large sign that depicted my representation of "Three Things and then Four Things". This showed three large black rectangles -



the one right in the middle was slightly raised and the other two on either side of it were at the same level. Then there were two other black rectangles on either side of the three in the middle. When someone asked me what it was I told them: "It's 111 in the middle and 1111 on the sides. It's a representation of [ALL SEVEN](#)." I'm not sure exactly what year this representation started to mean something to me. I connected with quite a few people at Woodstock who were seeing various number patterns. The most amazing one was a woman from Detroit who was wearing a T-shirt that said "Genesis 1:11". 111 was her lucky number and January 11th was her birthday. We both felt that this was a most amazing connection.

By this time I had also realized the connection between 7 and 111. 111 is the binary numeric representation of 7. 1111 is the hexadecimal representation of F, the last character of the hexadecimal character set. Also, in the early days of computers, a "1" quite literally meant that the ON/OFF switch was "ON". So 111 could also be seen as ON ON ON, which is obviously VERY similar to One-One-One. I also began to think of the ALL SEVEN representation as the self in the middle, the parents on either side (that's the 111 in the middle). And then the two ones on either side of the middle 111 represent the grandparents of the self - the genetic source material for each parent of the self.

A co-worker and I discovered that we had 111 "in common". He saw it all the time from 1985 through 1990. We were absolutely amazed.

During this period of time, I met many people who felt some sort of connection to AT LEAST ONE of the following number patterns: 11/111/x11/1111, 112, 22/222, 3/33/333, 316, 37, 44/44x/444, 47/x47, 53, 55/555, 666, 69, 7/77/777, 13/42, 23/32, 88/888, 1234, and 1212. For quite a while this list expanded almost every month. Early in the year 2000, I added 44x for a woman and her ex-husband who have always had a strong connection to the number 442. Previously, I had not added any new patterns to the list in about 3 years.

### ***1996 - THE QABALA Reveals Itself..***

I started seeing many connections between The Hermetic Order of the Golden Dawn, all things Masonic, other Egyptian Mystery School-based organizations (like the [Mormons](#)), the work of Aleister Crowley (I found more references to 111 throughout his work), [The Book of Knowledge: The Keys of Enoch](#), and the work of Solara & the Star-Borne. I saw physical similarities between the interlocking Triangles of the Golden Dawn, the Star of David, the Mason's Compass and Square, and the Star-Borne's Zone of Overlap. I also became less concerned with the ownership issues surrounding 111. I began to realize that "**the 111 experience**" was not something that I owned. It was something that had been there all along. I had just tapped into it.

I was still confident, though, that I was one of the first people on Earth to connect with a particular number pattern through the modern digital age. As more and more electronic digital devices came into being, more and more people started to notice their own particular number pattern more often than other patterns. In 1975, I was one of the first people in the world to own a digital wristwatch - it came right off the assembly line! This was the old LED-type watch where you had to press a button to see the time.

This early connection with digital timepieces may have had something to do with my experience. But then again, my first actual branding by 111 was in 1965! What still remained unanswered, though, was how a particular affinity developed for one number pattern over another. And why did certain people make this connection and others did not? Through the modern digital age, many people now experienced their own particular flavor of "**the 111 experience**".

I spent time with the [Hare Krishna](#) out in West Virginia during the summer of 1996 at one of their

Holy Temples. They were very interested in my study of 111 and of the ALL SEVEN concept. They were very hospitable to me during my visit. They really wanted me to join their temple and be a part of a special outreach group. I would have been working for the Swami that was the site's leader. I found literally dozens of Trinity references in their holy books. There were also a number of references to Seven Things throughout their literature. Although I did find their lifestyle interesting and was flattered by the treatment I received, I did not feel called to serve with them. They provided me with more insight into this mystery in general, and for that I was very grateful. They remained in contact with me for a period of time after I told them that I did not want to join them, but then stopped calling.

I finally connected with the foundation of my experience. In the late summer, my investigations of the Masons and The Golden Dawn led me to a common Root System that appeared to have fed different parts of each cosmology. It was the QABALA: the ancient science of revelation practiced in secret by the Hebrew Mystics of old.

The QABALA was actually what was being referenced in Crowley's "777" book that I had discovered in 1988. Throughout this experience, things have been revealed to me and connections have been made at just the right moment. Even though I was given glimpses of the QABALA back in 1988, I wasn't ready to begin my study of it until 1996. In "777" Crowley stated that the Hebrew Letter Aleph (A L P) was connected to 111. The correspondences for the Tree of Life related the letter Aleph to the first path on the Tree. This first path was also known as the "eleventh path". I saw [the "Three Pillars"](#) representation in the Tree of Life as well. It was quite reassuring to me that "**the 111 experience**" seemed to be connected to the QABALA. I knew for certain that my revelations concerning 111 had roots in other, more ancient systems.

### *1997 - Seeing More QABALISTIC Connections...*

This was a year for continued study of the QABALA. I also continued to see many significant public references to One-One-One - in speeches given by the Dalai Lama, in the slogans for the Episcopal Church's Presiding Bishop's Fund for World Relief, and on the cover of the bulletin for [my niece Rachel's baptism](#) .

At the end of the summer, I moved from my life-long hometown in [Sussex County, New Jersey](#) to the Heart of the Heartland - [Lawrence, Kansas](#) . I came out here to be with my new significant other. We met in a cyberspace chatroom called The Magic Dream Machine. She initially came to know me by my chat name (which was ONE\_1\_ONE). We bonded almost instantly. In September, we began our wonderful New Life together right here in Lawrence.

I acquired a copy of "Sefer Yetzirah - The Book of Creation" from a local bookstore here in Lawrence. I learned that this was perhaps the most ancient of all the Qabalistic texts. It was reportedly written by Abraham thousands of years before Christ and seemed to have provided the foundation for almost every Western Mystery School tradition that ever was. Some of what I found during my first experience with the Book included the following:

There are "32 mystical paths of Wisdom" ;

The Universe was created "with Three Books, with text, with number, and with communication" ;

There are "22 Foundation Letters: Three Mothers, Seven Doubles, and Twelve Elementals" ;

"Twenty-Two foundation Letters: He placed them in a circle like a wall with 231 Gates" ;

Many, many statements about the Three Mothers (the Hebrew letters Aleph, Mem, and Shin);

Many more references to Seven (which, as we have noted, is **111** in binary);

"Three: Water From Breath." ;

"Seven: Three opposite Three and one is the rule deciding between them...";

"...One on Three, Three on Seven, Seven on Twelve, All are bound, one to another."

### ***1998 - A Full Year in the Heartland***

This was again a year for continued study of the QABALA, continued observation of the innumerable similarities present between every one of Earth's Mystical Traditions, and continued self-study of Chaos Theory. It was also my first full year living in the mid-west. I spent most of my 36+ years living in New Jersey (where there are nearly 1100 people per square mile). And yes, I did live in Sussex County (the rural, less crowded NW portion of that tiny state). But my commute always took me down into the congested, hellish, suburban wasteland areas of the state at least 5 days a week.

Being way out here IN THE MIDDLE of the entire North American continent (where there are only about 30 people per square mile) certainly does have its advantages. Far from what most people back east think might be some kind of boring mid-west "cow town", Lawrence (where I live) functions as a cultural Mecca of sorts for the entire state. I've told people that I don't live in KANSAS - I live in the hip, happening [University](#) Town of Lawrence. Lawrence is an anomaly of a town out here in the Heartland and it has functioned as a wonderful resting spot for me that has allowed my "111/mystical work" to move forward in many interesting directions. I continue to remain eternally grateful to my new partner for having been the catalyst that brought me here.

In September, I added a section to the beginning of the write-up that described how I happened to come upon the name J'lahn. Since I got asked that question quite frequently whenever anyone new read the write-up, I thought I would just add that "background" information right up front. I also happened to be making that update to the write-up at roughly the same time [Flight 111](#) went down.

I did not know about the crash until sometime around noon the next day. Some of my friends back east informed me of the crash at the end of a conference call we were all on. They told me of the disaster and then added (rather ominously) "Guess what, Jim? It was Flight 111." And sure enough, it was Flight 111. So for the next several weeks quite a few people were contacting me and asking me how I felt about that. I said I felt really sad for the families and all the others that were involved with the tragedy.

But I also told them that I couldn't help it when these types of correspondences got linked to 111. Aleister Crowley once said (in the early 1900's) that 111 was "priceless" because of "its comment that the Unity [we seek] may be found in Thick Darkness and in Sudden Death." Perhaps Mr. Crowley had a premonition that Flight 111 would one day fall from the sky and sink to the darkest depths of the ocean suddenly killing everyone on board? Who knows. I first read those words in a town near Sedona, Arizona in July, 1988. And when I did, they frightened me. Was my experience with 111 tied to the fact that I would one day experience some kind of "sudden death" ?

My connection to 111 certainly did not seem to indicate that to me. I expect to continue encountering major life events and news stories that somehow get connected with 111. They have happened in the past and they will continue to happen in the future. For me personally though, this journey is still mostly undefined, raw, and real. And what happens outside of my own direct experience with [111](#) is entirely beyond my control.

During 1998, I attended a number of concerts in the Kansas City area. Prior to these shows starting, I would usually stand somewhere near the entrance to the venue with the [ALL SEVEN](#) sign (see Woodstock '94 section of the write-up). Many people found this very curious. And some others

actually got angry that I was carrying the sign. They wanted me to tell them what it meant. I told them that each of the seven "objects" were "undefined - that they were merely placeholders - that they were but crudely drawn representations of some as yet undefined concept - that they were [ALL SEVEN](#). " When it seemed like someone was actually interested, I told them of my "111 connection" (I gave them the URL to this site). I would also tell them how I felt that my "111 connection" had tied me into a direct experience with the QABALA. It was rather tough to do this because most people usually just think "what the heck is that guy talking about?" But it also was actually quite interesting and sometimes it really did provoke meaningful discussions about Mysticism that would not have otherwise occurred. After each time I did this, I would usually think to myself "Mission Accomplished."

As 1998 drew to a close, I was hoping that I would soon stumble upon a tie between my work with the QABALA and my work with Chaos Theory. This Grand Unification of the ROOT SYSTEM for all Eastern and Western Mystical tradition with the ROOT SYSTEM that describes, I believe, virtually ALL behavior on the physical plane continued to be my own, very personal, Holy Grail.

### ***1999 - The Journey Continues and, somehow, Begins to Change***

Please click below to read each of the year's iterative updates:

[January 11, 1999](#)

[April 21, 1999](#)

[November 1, 1999](#)

### ***January 11, 2000***

Well, we finally made it. The Year 2000. Since I was in my teens, I always knew I would be 37 in the Year 2000. I think everyone, at one point or another, figured out just how old they would be in this magical year. I want to say right up front that the new year IS magical, but not because it's the New Millennium (cuz it's not) and not because it's the New Century (cuz it's not that either). It's magical because even though it's a nearly completely arbitrary designation, it *is* a milestone. It is a milestone that was celebrated by the entire planet - even by those who know the year as 5777766 (Jewish), 7508 (Byzantine), 4636 (Chinese), 1921 (Indian), and 1420 (Islamic). But one thing it most definitely is NOT is the New Millennium. Nope. Not yet. I asked my closest friends to tell me if it's what we call a "stretcher" for me to see anything interesting or special about the date the REAL New Millennium begins (the "Third" Millennium). Let's see... what's that date again? Oh yes, it's **01-01-01**.

Yes, that's it. 01-01-01. Yup. The Third Millennium begins on January 1, 2001. Quite a few people know about this and many more are just now starting to find out as we plow on into this magical new year (the media inspired mis-use of this term is finally [THANK GOD] starting to die down). If you're wondering exactly why this is true, you can read what the [Royal Greenwich Observatory](#) has to say. They pretty much have the final word on these types of things, so I tend to believe them.

But all this dating stuff is so arbitrary, so I try to stay balanced about the fact that the THIRD MILLENNIUM BEGINS ON 01-01-01. OK. I'm a little excited about it, I'll admit that. OF COURSE, I SEE THREE ONES IN THERE!!! And yes, maybe it's a stretcher, but it's a *pretty cool* stretcher.

I took a different approach with the yearly roll-up activity. I just clipped the updates and put them in as links that folks can click on. 1999 was a relatively good year for us. I changed jobs (within the

same company) which has kept things on the work front active and interesting. And we rolled into our third (and perhaps final?) year out here in the Heartland. At some point, we just may decide to move back to Good Old Sussex County, New Jersey. We're very close with my family - my Mom and Dad are either in Florida or in the Poconos and my Brother and his family are down in Maryland. And my job can really be done from almost anywhere in the country (*especially New Jersey*). *But...* I have gotten so used to it out here - it's WAY less crowded than back east. We both really like that. So we'll see what happens.

**Back on the Paranormal Front:** I must confess that I made nearly ZERO progress during 1999 on my work with the so-called Grand Unification of the Qabala and Chaos Theory. I was just not pulled into that stuff like I was during 1998 and 1997. I sense that this past year was a transition year - a year when I took a breather, stopped or slowed down my OLD focus, and began to develop a focus on something NEW (not sure what). I do know that it is still my mission and sacred (!) duty to continue updating this write-up. I do still get mail from folks sharing their experiences - still mostly the "oh my God I'm not the only one" experience. I am also finding links to my story cropping up on other paranormal web sites.

I modified the entry pages for the site. I have put in a front page showing one of the earliest pictures I have of me with my folks. As you read above, you'll remember that I find the concept of [ALL SEVEN](#) very intriguing. I see the THREE rectangles in the middle of this representation as the Self, with each of the biological parents on either side. I see the TWO sets of TWO rectangles on either side of the THREE in the middle as the biological Grandparents of the Self. Of course [ALL SEVEN](#) fans out into hundreds of thousands of others who are all genetically linked to us. But somehow, I think there's something very special those first 6 immediate genetic relatives. Maybe it's because I had both sets of grandparents living until I was 15? Somehow, I feel that we forever travel through life in the middle with these THREE beings on either side - I actually liken it to what we saw in the Qabalistic text -

*"[Seven](#): Three opposite Three and one is the rule deciding between them...";*

And when some of us make the decision to have our own children, we spin off a brand new group of 7.

Whatever any of this all means, I sense that my entire experience with 111 is changing. It's still real, it's just that I may be ready to someday soon (perhaps when we enter the REAL New Millennium?) stop relaying all these details. Or the way I relay these details will change somehow. The April 21st update will come out a little early this year - because of Leap Year, April 20th is the 111th day of the year. Get your [ADOBE ACROBAT](#) software before then folks because I'm going to be making old "hard copy" versions of "**the 111 experience**" available to you all as 'pdf' files - including the very first hand typed version! NOW WON'T THAT BE SPECIAL!

Enjoy the next 3 months. Feel free to write me if you want to share your own experiences or if you have feedback on mine.

### ***April 20, 2000***

Since this is a leap year, the 111th day of the year falls on 4/20. And, unfortunately, it is another facet of "**the 111 experience**" that ties into something, well, not so cool. Something **evil**, actually. Today, the 111th day of the year 2000, is the 1st anniversary of the Columbine Massacre. Those shots that rang out at **11:19** on that fateful day last year changed so many lives - forever. The Demons (judgment call on my part) that made this happen chose 4/20 for a very specific reason (or at least that is one of the theories). You see, 4/20 is Adolph Hitler's birthday. And the really unusual fact about this, the day of the 1st anniversary of the Columbine Massacre, is that it would have been

Adolph Hitler's **111th** birthday. That is obscure, but true. As with any dark correspondence to 111 (Crowley, Flight 111), I wish these things were not true. But they are. Like I have said in previous versions of the write-up, I do not have control over what gets linked into 111. So sometimes I have to just roll with the punches, acknowledge the unsavory events, and move on. That's what I'll be doing with this year's rather negative 4/20 correspondences.

Over the past few months I have had some particularly disturbing e-mail and message-board replies from people telling me that my association with 111 is absolutely, positively, demonic. These folks believe that I am somehow, under the influences of EVIL DEMONS, possessed by 111. They see 111 as just a bit too close to '666'. They see 111 as something that distracts me and takes me away from a (Christian) life with God. It is true that I am not a Christian. But I would beg to differ with anyone who thinks that it is because of [111](#) .

I am a Searcher and a Scientist. I am one who is in the process of discovering Truth. I always will be. I accept the mysteries that surround me and try to remain balanced as to the "meaning of it all". I remind people who ascribe 111 to evil that the binary number 111 is equivalent to the number 7 in decimal. One of the "Most Holy" numbers on the planet is directly linked into 111. I also remind them that 111 seems to me to be a numeric code for some sort of Trinity - why not call it a miraculous sign of the Christian "Father, Son, and Holy Ghost"? Why not? I guess all I try to say to these folks is this - read the WHOLE write-up, examine my experience, and draw your own conclusions. I've already stopped responding to a few folks who accuse me of having some kind of Satanic connection. It just simply is not true. When it comes to these matters, I am to be seen as a Free Agent, an Anomaly that defies Good/Evil categorization. That is my role. And that is the role I will continue to operate in.

This is also the update where I promised to present some ancient versions of "**the 111 experience**" for your viewing pleasure. You'll need an Adobe Acrobat reader to view them. When you look at them, you'll see that certain areas are "blacked out" with magic marker. This is because I used a person's name, address, my company's name, or some other facet of the tale that, at this point, needs to remain unknown. Rest assured, this is just to protect me legally. Anyway, I have included the following:

The very first typed version of "**the 111 experience**" complete with hand-written corrections. This was typed on a Cannon Typestar 5 portable typewriter in the late 80's. Click [HERE](#) to view.

The very first version of the write-up written on a computer running on Windows. My laptop was running Windows 3.1 when this was created (early 90's). Click [HERE](#) to view.

Miscellaneous update details since 1992 that have now been eliminated from the present-day version of the write-up. Click [HERE](#) , [HERE](#) , and [HERE](#) to view (I split it up into three parts to make the download into your Acrobat Reader quicker).

Some may wonder why I am doing this. If these are really old, discarded versions, why not leave them in the past where they belong? Well, for one thing, it is to add an additional layer of historic detail to show folks how the experience has progressed over the years. You will see that I, too, was fascinated by *every single little occurrence of 111* that popped up into my face. I really understand why, for some of you who are just beginning this experience, every occurrence of your special number pattern is something that BLOWS YOU AWAY. I remember what that was like, I really do. But at this point, as you have seen in previous updates, it really takes a HUGE, completely OBSCURE event to catch my interest. It's not that strange things relating to number patterns don't happen, it's just that they happen all the time. They happen with such regularity that they no longer influence me the way they used to.

Synchronistic events abound. They all have messages attached. At this point, I filter out quite a bit - things that normal people interested in the paranormal (is that an oxy-moron?) would be BLOWN

AWAY by. It comes with the territory. This number pattern business has been happening to me for SO LONG at this point. As I also suggested in previous updates, my experience with 111 is changing. It is quite possibly something that I will simply let go of - SOON.

It doesn't mean that I won't look back fondly on it, it doesn't mean that I won't continue to be a clearinghouse for information about this experience, and it doesn't mean that my experience will have been invalidated. It just means that it will change. I won't know how it will change until it changes. This is just one of those things that I sense is true - I do not have any hard evidence for what the change will look like or exactly when it will occur. But it's coming.

Whatever happens, enjoy the next bunch of months between now and 11-1. A side note: I will be removing the 5-5-2000 link from the front page of the site on 5-6. It's my assumption that 5-5 will come and go like any other May 5th - this will enrage some and will be inconsequential to others. My continuing advice about ALL this stuff - stay real, stay undefined, wait it out - the Truth around these experiences is coming. Soon. You'll know it when it happens. Stay cool.

### ***November 1, 2000 - The Final Update***

I got an e-mail from someone the other day talking about "the 555". What we are being told is that many folks ("Lightworker" type folks) around the globe are now connecting with this "new" Number Pattern - 555. It's coming up in all the usual places (odometers, prices, clocks, "randomly generated" ID numbers, etc.). And yes, it's already one of the numbers you'll find in my well documented Number Pattern list:

**11/111/x11/1111, 112, 22/222, 3/33/333, 316, 37, 44/44x/444, 47/x47, 53, 55/555, 666, 69, 7/77/777, 13/42, 23/32, 88/888, 1234, and 1212.**

It's great that these folks are now getting all jazzed over 555. It really is. I wish them All The Best as they begin their search to ascribe meaning to this "new" Pattern. I met someone over 10 years ago who was jazzed by 555. That's how it ended up on my list. Personally, I have a more clinical approach to "the 555". I guess I just see it as another Case in my very large Case File. I think that maybe since I have been doing this number pattern business longer than nearly anyone else on Earth, I find myself less and less moved by the phenomenon itself. To me, the business of "connecting" with Special Number Patterns seems OLD, OUTDATED, and in need of some kind of NEW SPARK. It's not that my experience with 111 didn't connect me with tens of thousands of interesting people and hundreds (perhaps thousands) of interesting topics and movements. On the contrary, my experience with 111 really became a permanent, defining characteristic of my Self, my essence. I'm actually very grateful for the role that was dumped in my lap some three decades ago.

Since the following quote is buried on one of the above links (November '99), I'll repeat it again right here since it seems appropriate at this time:

*It has been a **REALLY** long time since the act of simply seeing the number "111" really meant anything to me (at all).*

Don't get me wrong - I still think 111 is cool. WAY COOL. The fact that it's the binary representation of SEVEN is VERY COOL. The fact that it uniquely symbolizes All Trinities in a way that dazzles us with its simplicity is EVEN COOLER. It's not just Unity; it's Tri-unity - an encoded symbol for nearly ANY Trinity.. I recognize the fact that the 1 means "ON" in the binary language of computers. So I see how 111 is very similar to ON-ON-ON (One-One-One? Get it?). The fact that we see Trinities and SEVEN cropping up across the [Qabala](#) , Eastern and Western Mystical Traditions, and the mainline Religious persuasions all across the globe is undeniable. And I still think all that stuff is rather interesting. But what does it all really mean? That's the REAL

question and that's what folks have been trying to get me to comment on and commit to since the Fall of 1980. That's over 20 years. That's quite a *long* time.

If you connect to a particular number pattern (and it's probably one of the ones listed above) I want you to stop and think about it for a minute. Where did it come from? Who mentioned it to you first? Did you simply start noticing it without anyone prompting you? For the vast majority of folks connecting to a pattern, they were told about the pattern or they read something about it first BEFORE they started "connecting". That realization should hold some kind of a key for you. Give it some thought.

When I first started seeing 111 all over the place in 1980, not a soul had told me about it. That fall (Fall, 1980), I told hundreds of people about 111 and then they started seeing not just 111 but 11:11 as well. Does that mean I might have started a bunch of people seeing 11:11? Let's think about that. This occurred in the densely populated region of NJ right across the Hudson from New York City. Some of the earliest reported 11:11 sightings I have come across are from Long Island, NY. I went to school with several people from Long Island. Is it possible that I actually launched this phenomenon in 1980 from the densely populated NYC metropolitan area? Is it possible that it then spread like Wild Fire from that very location (and SO ON and SO ON and SO ON)? It's absolutely possible! "11:11 - Make a Wish" --- ever heard of that? If you have, do you know anyone that was saying this prior to the early 80's? I believe this phrase originated on Long Island somewhere between 1980 and 1985. So what's the point? By this time, if you have any doubts at all that my experience with 111 and 11:11 predates nearly everyone else's on Earth (yes, the entire planet), you either haven't been paying attention or you're in some strange form of denial. It's not like I'm bragging. I'm simply stating fact.

So, after "connecting" with [111](#) for so many years and covering it from so many different angles, I believe I am moving on. I have reached a conclusion:

*I believe that "Connecting with a Special Number Pattern" has a definite, pre-determined life cycle. I'm going to put it at anywhere from 10-35 years. After that life cycle has concluded, the special pattern has outlived its usefulness and is either discarded or it is changed into something else. It's as simple as that.*

With 20 years of active sightings and a 35 year connection to 111 and 11:11, I've absolutely reached that point. The life cycle, for me, of 111 (and 11:11 in its present form) has concluded. Does that mean I'll now look back on this experience and say "Oh My God, what a colossal waste of time!" ??? No, it doesn't mean that at all. It means that it is time to move on into a New Role and a New Way of looking at my particular good ol' pattern. I think this is a point that each of you will reach with your pattern. It's just that you haven't gotten there yet. But you'll know it when you do. When it happens, don't be embarrassed, just let it go. If you know someone who "connects" and they have been telling you about their special pattern for years now and you have been saying "well, gee, that's nice" but have been mostly scratching your head over the whole thing, give them time. It will expire. I don't usually quote much from anyone else in this web site, but even our friend Solara knows that eventually "the 11:11" will "transfer" and "transform" into [something else](#).

So, where does that leave this website? Well, I'll still be indexed and linked for number patterns and 111 and 11:11 so I will still get folks e-mailing me wanting answers and/or just wanting to share their experience. I'll continue to reply to as many of those e-mails as possible. But the website will change to include more of an overview of ALL the patterns and it will also include my commentary on the groups or individuals who "claim" the pattern. This site will become more of what I had always said it would be in the first place - a clearing house for this type of information. I'll also be [expanding the site](#) to include a section on non-number-pattern related mysticism.

In closing, please remember what happens in January. I'll just cut and paste my quote from above -



"I asked my closest friends to tell me if it's what we call a 'stretcher' for me to see anything interesting or special about the date the REAL New Millennium begins (the 'Third' Millennium). Let's see... what's that date again? Oh yes, it's

**01-01-01.**

Yes, that's it. 01-01-01. Yup. [The Third Millennium begins on January 1, 2001](#) ."

'Nuff said.

*My REAL journey with **the 111 experience**, while it will always remain near and dear to my heart, has concluded. The write-up is now considered "archived in place". There will be no further updates.*

[J. W-N](#), LocalSuperCluster, [UNI-1], [11-1-2000](#)

---

# Synchronicity

by [Nicholas Knutsen](#)

[madforest.com](http://madforest.com)

*The thing with synchronicity as opposed to other "paranormal" phenomena, is that synchronicity in theory is not paranormal. It is a scientifically possible factor, although it's well on the outside of traditional science, and of course it's never been proved to be real. In fact, it would probably be impossible to prove that synchronicity really is an existing phenomenon, at least by using the normal methods of scientific deduction. This is because synchronicity operates completely outside the current laws of physics as defined by scientists.*

*A funny and informative book which also deals a little with synchronicity, is "The Fourth Dimension (and how to get there)" by Rudy Rucker (Penguin Books 1986). The only book which is all about synchronicity that I know of, is of course the original by C.G. Jung, "Synchronicity - An Acausal Connecting Principle". Jung was the one that created the word and also the theory on synchronicity.*

*The theory is that events (and thoughts) are connected in other ways than causally. "Causally" meaning by the law of cause and effect. In traditional physics all events have a cause, something that made exactly that event happen ("The clockwork universe"). This would mean that if we had all the existing factors, we could calculate exactly what would happen in any given system. For instance, if somebody kicks a ball up in the air, if we know the weight of the ball, the exact angle of impact by the foot, the force with which the foot hit the ball, the shape of the tip of the shoe, the wind velocity and direction (and all factors about the wind currents), and so on... then we could in theory say exactly where the ball would land.*

*But as quantum physics proved, this causality (and ORDER) only applies on certain levels. (Remember, all laws of physics are simply statistical.) In the microverse, i.e. on a sub-atomic level, all the laws of physics are out the window. Chaos rules. Particles can be on two places at the same time. Particles can travel back in time. Things happen for no reason, i.e. the effect has no cause. The very particles that make up the physical world as we perceive it, do not follow the laws that they create by their "behavior"! One cannot predict where a particle will go next, or even the behavior of an atom. In fact, also outside of the microverse it is now understood that a given cause does not always produce the same effect, although it might SEEM that way in most instances. (Laws of physics are statistical.)*

*Anyway! If causality does not govern everything, then there could theoretically exist an ACAUSAL connecting principle. Two events which are somehow connected, but neither of them caused the other one to happen. This is synchronicity. If synchronicity does not exist, then the world is just full of strange coincidences. But if it does, then the world is filled with MEANINGFUL coincidences. Telepathy, divination, astrology and such are potentially possible under the theory of synchronicity. But they don't occur for the traditionally believed reasons. Telepathy, meaning that one could "read" another person's mind, suggests some sort of thought waves, and this is not in accordance with physics. But it's possible that two people can think of something at the same time. Under the theory of synchronicity, all such events would be synchronistic. If a person is more inclined to certain synchronistic phenomena than others, she/he could be perceived as a telepath. Similarly, an event in the future or the past could be connected with an event in the presence; and the*

*constellation of the stars and planets could be connected with elements in human's lives. (Of course, this is all very difficult to chart, and I believe that the "science" of astrology is too specific to have the possibility of being accurate.)*

*Synchronicity has much in common with the increasingly popular Chaos Magic(k). In "Liber Chaos" by Peter J. Carroll, the author uses quantum physics to explain the theory behind chaos magic, and although synchronicity is never mentioned, the similarities are evident .*

*In "The Fourth Dimension", Rucker explains the following: In quantum physics, the movement of matter in space and time are thought of as patterns in the spacetime fabric. In a Minkowski diagram, an object moves through space on the x-axis (horizontally) and time on the y-axis (vertically). We trace the object by drawing its "world line". A straight vertical line means that an object only moves in time, i.e. it's motionless (in space). If the line is in an angle e.g. to the right, it means that the object is in motion. The sharper the angle, the faster the motion. These lines are more or less vertical, and represent causal events. (A straight horizontal line would mean that the object was traveling infinitely fast, or "teleporting".) All synchronistic connections would have to be a "horizontal patterning" in spacetime, as opposed to the "vertical patterning" of causality.*

*In "Liber Chaos", Carroll explains chaos magic also as patterns in reality; and they work through what he calls "shadow time" as opposed to normal time. Shadow time is perpendicular (in right angle) to normal time. It is as if Rucker and Carroll are talking about the exact same thing!*

*To me it's obvious that the workings of synchronicity (or magic) are such that reality wouldn't be as it is without it. Reality is defined by synchronicity (among other factors). Synchronicity is at least essential to the underlying "patterns" or "laws" that define reality.*

*Both Carroll and Rucker conclude that synchronicity/magic is the very thing that shape our reality. It's not just meaningful coincidences or the altering of reality (by magic). Carroll says that the reason the universe is like it is, is magic; the universe IS magic. Rucker says: "When both patternings [causal and acausal] are at work, one gets the kind of complex pattern of events characteristic of life as it is lived. It seems evident that a really first-class universe must include a mixture of both sorts of spacetime patterning. What I am suggesting, in short, is that our world contains synchronicity because it is a beautiful and interesting world!"*

*Modern scientists have found that at the underlying level, all is chaos. Different aspects of this manifest in the fields of quantum mechanics; quantum physics; chaos theory (fractals); chaos magic, and probably others I can't think of now. However, in recent years, scientists have tried to find the answer to why the world at our level then seems to be governed by such mathematical and orderly laws. This field is called complexity. I haven't read much about this actually, but it would seem to me the answer they are looking for, is synchronicity!*

*What is interesting is that "Liber Chaos" is a sort of manual in how to perform chaos magic. If this is possible, it would mean that one could actually control the synchronicity around us. According to this book, the way to perform chaos magic is to first put the result you want, into your mind. Then you must not think about it when the ritual or the action is happening. That is to say, the wanted result should be in your subconscious mind, not your conscious mind. However, in order to make it work you should be in a state of great excitement or agitation when performing the ritual.*

*One way to do it is the use of sigils. Here's a simple example: You write down the wanted result, for instance "I WILL WIN A MILLION DOLLARS IN THE LOTTERY". Then you combine all unique letters into a self-defined graphic sigil, which is like your spell. Now you must forget what this sigil means. A common way to do this is to have many sigils stored with different meanings. When you then use one of them, you don't remember what it stands for. Now the agitation comes in. You reach*

*this state by performing "gnosis", which can be a ritual dance with music, a sexual experience, or any form of self-suggestion; but all the time focusing on the sigil. All this is to ensure that the objective lies in your subconscious mind. Many practitioners of chaos magic (or chaoists) also create their own pantheons with gods, demons etc, or use existing deities. For instance, there's the IOT pact, The Illuminates of Thanateros, who worship Thanatos and Eros. But all chaoists are atheists, so the worshipping and rituals are all a means of self-suggestion. The trick is to believe even though you don't believe, because of course the magic is much more likely to be successful if you believe it can be.*

*There's no apparent logic behind these methods of performing magic; they are not based on science, but probably empiric research. But I have found, even before I heard anything about chaos magic, that synchronicity works in much the same way. For instance, I think everybody knows that something most often does not happen when we think consciously about it. If we're waiting for a phone call, the phone will not ring when we're thinking about and waiting consciously for it to ring. When it rings, it's when we let our guard down for a minute, and the mind wanders to some other thoughts. Similar things have happened to me countless times. I've rolled some dice in order to get two 6s and thereby winning a free hot dog and soda at a hot dog stand. I did this many times, once every time I went by, and never getting boxcars. Then one day when I didn't have ANY hope of shooting double 6, and I just rolled the dice to get it over with, I got double 6. This can also work against me. I watched a TV series once, primarily waiting to record one special episode of the show, but not knowing when that episode would be aired. There were more episodes than I originally thought. I started recording every time in case it was the episode I wanted. Remarkably, I never forgot one episode, which is pretty uncommon when it comes to me. Then one day I did forget. Half way through the show, I remembered it was airing, and I switched on the channel, thinking for a split second that it probably is the one I've been waiting for. It was. The first and only one I forgot. Even more amazingly, it was the very last episode they aired, out of at least more than eighty.*

*These are examples of the subconscious/conscious mind factor. The other factor, concerning gnosis, may also have some basis in reality. The more you think about a thing or are excited about a thing, the more likely it is to happen (provided you don't have it in your conscious mind when it's supposed to happen, of course). (Another factor presented in "Liber Chaos" is that the more unlikely it is for something to occur WITHOUT any "magic ritual", the more difficult it is to make it happen; and the more gnosis is required, and the more you must exercise it from your conscious mind.)*

*Actually, this is similar to something Jung found in his synchronicity experiments. He performed ESP experiments with the five cards with shapes on them (I can't remember what they're called), circle, square, waves etc. The results he got was better (higher frequency of correct guesses from the subjects) early in an experiment, when the subject was excited and thought the experiment was fun. When he/she became more tired and bored, his/her score dropped. Jung didn't put this result into a greater context.*

*Well, these methods of actually influencing synchronicity (i.e. performing chaos magic) are pretty theoretical; and I have found that synchronicity is very difficult to influence. Of course, I haven't performed any real chaoist rituals either, only tried out the theories in more mundane settings. But I think that synchronicity is a much more complex phenomenon than it seems, and how it works is very much beyond anything we can hope to understand as of yet. I don't think there's being done any kind of research or scientific theorizing on the subject either, at least not under the name synchronicity and in the tradition of Jung.*

*I realized now that this text is filled with a lot of theoretical explanation, and not much anecdotal*

*information, which was maybe what you asked for... I've had many amazing synchronistic experiences the past years, but it's difficult to think of the details of any one in particular.*

*OK. One experience that comes to mind also involves videotaping, for some reason. I was taping the series "Women and Men", an HBO series where well-known actors played in adaptations of classic short stories. I went to school at the time, and the episodes were aired during school, so I had to program my VCR. One day I had for some reason missed last English class and I didn't know what the homework was for the English class I had that day. ON THE WAY to the English class, I found out that we were supposed to read the short story "Hills Like White Elephants" by Hemmingway. I looked at my watch, and realized I was taping the HBO adaptation of that very short story at that very time (with James Wood and Melanie Griffith). I told the teacher this, who happened to walk beside me, and he thought I was taping it because it had been our homework to read it.*

*Another thing that seems to happen, is that when you're very preoccupied with synchronicity, it tends to increase, at least for a time. When you think a lot about synchronicity, your synchronistic experiences become more frequent. This can be explained synchronistically, of course: When you think a lot about something, it's more likely that that thing, or something related to that thing, is going to happen. If you then get so used to synchronistic events that you don't really think about synchronicity when it's not actually happening, the events tend to get less frequent again. This COULD be an explanation.*

*The critics will of course always say that there are no meaningful coincidences; it's all due to self-suggestion. Rudy Rucker gives this example: If you have your arm in a cast, it's more likely you will notice other people with casts too. But this may not mean that there weren't just as many people with casts around before; you're just noticing them now, because of your own cast. BUT according to quantum mechanics, reality as we now know it is the product of an interaction between the objective world and the subjective observers. The individual's frame of mind influences what happens to him/her. Jung says: "Synchronicity takes the coincidence of events in space and time as meaning something more than mere chance, namely, a peculiar interdependence of objective events among themselves as well as with the subjective (psychic) states of the observer or observers." If, as I've said before, synchronicity is an integral part of our experienced reality, there is no contradiction between the notion of meaningful coincidence and the explanation of self-suggestion. I can just look at a natural thing like a tree, or a man-made thing like a pair of scissors, and I see that the world is synchronistic, under that or any other name.*

*---*

*I hope that didn't sound too preachy. I do have an open mind as to what this world really is, but the synchronicity theory is one that seems very right to me. But it IS just a theory. I'm really, technically, an agnostic; I don't think we'll ever know what it all means. (Synchronicity is actually unexplainable too.) But functionally I guess I'm an atheist and a synchronist.*

*Stay afloat!*

*Nicholas*

## Francis C Biley

### An experiment in accessing pandimensionality: The literary poetics and deconstruction techniques of William S Burroughs applied to the Science of Unitary Human Beings

#### University of Wales College of Medicine

<b>Slide: Blank</b>	Say Nothing
<b>Slide: I am what I am</b>	Say Nothing
<b>Slide: Tarantino</b>	"How is bread made?"  "I know that" Alice cried eagerly.  "You take some flour..."  "Where do you pick the flower?" the White Queen asked, "In a garden or in the hedges?"  "Well, it isn't picked at all" Alice explained, "it's ground".  "How many acres of ground" said the White Queen.
<b>Slide: Finnegans Wake</b>	riverrun, past Eve and Adam's, from swerve of shore to bend of bay, brings us by a commodius vicus of recirculation back to Howth Castle and Environs.
<b>Slide: William Sewart Burroughs</b>	Say nothing
<b>Slide: Pulp Fiction</b>	Say nothing
<b>Slide: Breton</b>	neatest little hussy, with his ghost town approach, her face is science fiction but she wears a dollar brooch, sweetly reminiscent, something mother used to

bake

**Slide: diamond dogs**

**Slide: James Joyce**

**Slide: word image virus**

I want to build a language in which certain falsifications inherent in all Western languages will be made incapable of formulation

**Slide: Naked Lunch**

Say nothing

**Slide: cut me I bleed**

say nothing

**Slide: Cut the text**

A mutation in consciousness will occur spontaneously once certain pressures are removed. The principal instrument of monopoly and control that prevents the expansion of consciousness is the word

**Slide: Feel the truth**

say nothing

**Slide: Ask no questions**

say nothing

### ***Powerpoint off***

This is Charles' story:

### **Video on**

It was a warm, but overcast day and the rain had gently began to fall.

On holiday in France at a Camp site had been a lot of fun and pleasure.

There were three pools on a single site.

One small one for the toddlers,

a medium one for the fast slide

and a larger pool for the serious swimmer.

Jamie was in the larger pool.

His friend had just arrived at the pool and they were playing together.

As Jamie staggered out of the large pool he instinctively went to his mother.

Sitting some distance away  
at the other end under the shelter,  
he staggered helpless towards her.  
Unable to control his walking he fell into the small pool.  
Jan thought that he was messing about.  
The realisation that there was something wrong is a sudden and frightening experience. Jan in sheer helplessness placed a towel around him.  
Jamie fell into the seat.  
David who was watching said that Jamie was unable to sit on the seat.  
She ran to me and told me that Jamie had hurt himself.  
As I got out of the pool and walked towards Jamie  
I realised that something was very wrong.  
Convulsed with arms raised high up in the air he was unable to breath.  
I cannot remember what I said but it was foul.  
As I lay Jamie down on the ground he tried hard to say something but was unable to get the words out.  
In the end it sounded like a groan.  
I immediately started to do mouth to mouth and was able to see his lungs inflate.  
His colour at that time was rather grey and cold.  
Jan had run off to get an ambulance and I was not conscious that our other three children were watching.  
Later someone took them away.  
Asking someone else to find a pulse they said that they couldn't.  
I did cardiac massage and mouth to mouth.  
Later someone gave a hand.  
I remember someone telling me that I was doing fine.  
I am not aware how long it took for the ambulance to arrive.  
But the ambulance men immediately took over.  
I wanted to keep breathing for him but they sort of took charge and moved me aside. They initially bagged him and then attached him to a ventilator.  
They also got access through a vein.  
Two doctors arrived.  
They kept injecting him and got him attached to a monitor.  
I remember telling a British Doctor  
who happened to be on holiday  
that if Jamie got through this "I would kill him".



He said "That's the spirit"

Now I wish I hadn't said it.

I realised Jamie was dead when I saw his pupils slowly dilate.

He looked rather peaceful and handsome lying there.

The doctor came up to me to say how sorry he was.

He looked very unhappy.

I walked back to the tent in a dazed state.

Met the two boys walking with a lady and just said that we had 'lost Jamie'.

The camp owner came to see us and the person in charge of the activities.

She really didn't know what to say,

she must have been about seventeen.

They were arranging for us to go and stay in a hotel.

The rest is very vague.

We just walked and cried.

We played mini golf and cried.

Sat in the hotel restaurant and cried.

Played Tennis and cried.

It was the most pain I have ever had.

We all had to sleep in the same room in the night because the boys were so scared.

I woke up screaming

unable to breath.

While everyone around us were attempting to enjoy themselves we were just so upset and devastated.

The insurance company made all the arrangements for us to come home and to have our car driven home.

It was hard to leave when Jamie had to stay.

He came home a week later and there was a considerable amount of paper work to get him home.

He came back to the Hospital and an autopsy and I remember passing the Forensic department thinking that he was in there.

Jan and myself went to see him at the funeral home before he was buried.

He still looked very good.

The funeral was done quickly and was totally unemotional.

The boys dressed up and none of us cried.

It was just too painful.

I read out something that I wrote about him

and his friends from school came.

The funeral music to the terminator in Terminator 2 will always be his music.  
It is powerful and positive.  
Gradually, the pain goes but life is never the same again.

**The cut-up text.**

His colour at that time was rather grey and cold.  
In the end it sounded like a groan.  
I immediately started to do mouth to mouth.  
Later someone took them away.  
Asking someone else to find a pulse they said that we had 'lost Jamie'.  
His colour at that time was rather grey and cold.  
Jan thought that he was unable to breath.  
While everyone around us were attempting to enjoy themselves  
we were just so upset and devastated.  
thinking that he was in the hotel restaurant and cried.  
Sat in the hotel restaurant and cried.  
It was the most pain I have ever had.  
We all had to sleep in the larger pool.  
She really didn't know what to say  
but was unable to sit on the ground  
he tried hard to leave when Jamie had hurt himself.  
As I lay Jamie down on the seat.  
David who was watching said that we had 'lost Jamie'.  
The camp owner came to see his lungs inflate.  
His colour at that time was rather grey and cold.  
Jan had run off  
to get him home.  
He came home a week later.  
There was something wrong,  
it is a sudden and frightening experience.  
Jamie fell into the seat.  
David who was watching said that Jamie had to sleep  
in the same room  
in the larger pool.  
He looked very good.  
Later someone gave a hand.

David who was watching said that we had 'lost Jamie'.  
The camp owner came to see him at the pool  
they were playing together.  
As Jamie staggered out of the pool  
I realised Jamie was unable to breath.  
They were arranging for us to come home and to have our car driven home.  
It was just too painful.  
Two doctors arrived.  
They kept injecting him and got him attached to a ventilator.  
They also got access through a vein.  
Two doctors arrived.  
They kept injecting him and then attached him to a monitor.  
I remember someone telling me that Jamie was unable to breath.  
As I got out of the pool and walked towards Jamie  
I realised he was dead  
when I saw his pupils  
slowly dilate.  
He looked very good.  
His colour at that time was rather grey and cold.  
I realised that something was very wrong.  
Convulsed with arms raised high up  
in the hotel restaurant and cried.  
It was just too painful.  
I read out something that I wrote about him  
and got him attached to a monitor.  
I remember someone telling me that Jamie had to sleep in the larger pool.  
His friend had just arrived at the other end under the shelter,  
he staggered helpless towards her.  
Unable to control his walking he fell into the small pool.  
Jan thought that he was buried.  
He still looked very good.  
The funeral was done quickly and was totally unemotional.  
We just walked and cried.  
We played mini golf and cried.  
Sat in the larger pool.

His friend had just arrived at the other end under the shelter,  
he staggered helpless towards her.  
Unable to control his walking he fell into the small pool.  
Jan thought that he was unable to breath.  
While everyone around us were attempting to enjoy themselves  
we were just so upset and devastated.  
Later someone gave a hand.  
The realisation that there was something wrong is a sudden and frightening experience.  
Jan in sheer helplessness placed a towel around him.  
Jamie fell into the seat.  
David who was watching said that they couldn't.  
I did cardiac massage and mouth to mouth.  
Later someone took them away.  
Asking someone else to find a pulse  
they said that Jamie had hurt himself.  
As I got out of the pool and walked towards Jamie  
I realised Jamie was in there.  
Jan and myself went to his mother.  
Sitting some distance away at the other end under the shelter,  
he staggered helpless towards her.  
Unable to control his walking he fell into the seat.  
David who was watching said that Jamie had to sleep in the hotel restaurant and cried.  
It was hard to leave when Jamie had hurt himself.  
As I lay Jamie down on the seat.  
They were arranging for us to come home and to have our car driven home.  
It was the most pain I have ever had.  
We all had to sleep in the night because the boys were so scared.  
I woke up screaming  
unable to breath.  
It was the most pain I have ever had.  
We all had to stay.  
He came home a week later  
and there was something wrong  
it is a sudden and frightening experience.  
Jan in sheer helplessness placed a towel around him.

Jamie fell into the seat.  
I did cardiac massage and mouth to mouth and was totally unemotional.  
The boys dressed up and none of us cried.  
Later someone took them away.  
Asking someone else to find a pulse they said that they couldn't.  
I did cardiac massage and mouth to mouth and was totally unemotional.  
The boys dressed up and none of us cried.  
While everyone around us were attempting to enjoy themselves  
we were just so upset and devastated.  
It was hard to say how sorry he was.  
He looked very unhappy.  
I walked back to the tent.  
The rest is very vague.  
We just walked and cried.  
Sat in the larger pool.  
His friend had just arrived at the pool and they were playing together.  
As Jamie staggered out of the large pool  
he instinctively went to see him at the other end under the shelter,  
he staggered helpless towards her.  
She ran to me and told me that Jamie had to sleep  
in the air  
he was unable to breath.  
I cannot remember what I said but it was foul.  
As I lay Jamie down on the seat.  
David who was watching said that Jamie had to sleep  
His colour at that time was rather grey and cold.  
Jan had run off to get him home.  
He came home a week later  
there was a considerable amount of paper work  
In the end it sounded like a groan.  
I immediately started to do mouth to mouth.  
Later someone took them away.  
Asking someone else to find a pulse they said that we had 'lost Jamie'.  
The camp owner came to see us  
and the rain had gently began to fall.

Asking someone else to find a pulse they said that they couldn't.  
I did cardiac massage and mouth to mouth.  
Later someone took them away.  
Asking someone else to find a pulse they said that they couldn't.  
I did cardiac massage  
and mouth to mouth  
and was totally unemotional.  
The boys dressed up and none of us cried.  
It was just too painful.  
I read out something that I was doing fine.  
Jamie was in there.  
Jan and myself went to his mother.  
Sitting some distance away at the pool and walked towards Jamie  
I realised Jamie was dead when I saw his pupils slowly dilate.  
He looked very unhappy.  
I walked back to the tent in a dazed state.  
I did cardiac massage and mouth to mouth and was able to see him at the pool  
and walked towards Jamie  
I realised Jamie was unable to breath.  
While everyone around us were attempting to enjoy themselves  
we were just so upset and devastated.  
As I lay Jamie down on the ground he tried hard to leave  
when Jamie had hurt himself.  
As I lay Jamie down on the ground he tried hard to live  
restaurant and cried.  
Played Tennis and cried.  
Played Tennis and cried.  
Sat in the air  
he was unable to get an ambulance  
and I was not conscious that our other three children were watching.  
Later someone gave a hand.  
I realised that something was very wrong.  
Convulsed with arms raised high up in the air he was unable to breath.  
While everyone around us were attempting to enjoy themselves  
we were just so upset and devastated.

Met the two boys walking with a lady  
and just said that we had 'lost Jamie'.  
The camp owner came to see us  
and the rain had gently began to fall.  
On holiday in France at a Camp site had been a lot of fun and pleasure.  
But the ambulance men immediately took over.  
I wanted to keep breathing for him but they sort of took charge and moved me aside.  
They initially bagged him and his friends from school came.  
The funeral music to the terminator in Terminator 2 will always be his music.  
It is powerful and positive.  
Gradually, the pain goes.  
Jan thought that he was in there.  
As I lay Jamie down on the seat.  
She ran to me to say how sorry she was.  
He looked rather peaceful and handsome lying there.  
It is powerful and positive.  
Gradually, the pain goes.  
I wanted to keep breathing for him but they sort of took charge and moved me aside.  
They initially bagged him and then attached him to a monitor.  
The rest is very vague.  
We just walked and cried.  
It was just too painful.  
I read out something that I wrote about him.  
They also got access through a vein.  
Two doctors arrived.  
They kept injecting him and got him attached to a monitor.  
I remember someone telling me that Jamie was in there.  
Jan and myself went to see  
and the rain had gently began to fall.  
On holiday in France at a Camp site had been a lot of fun and pleasure.  
I realised that something was very wrong.

[Video On](#)

# The Quantum Writing Experiment

Jake D. Steele

AuthorsAudio

As you know WSB I believe got the basic ideas for his Cut -up technique from Bryon Gysin , an artist and transferred the technique , in his own manner to doing writing cut ups . See Nova Express , I am sure ... parts of Naked Lunch etc.. He did this from what I can gather , to explore the unconscious and the ability for the " NOW " moment to create connections we ... perhaps didn't really see . I heard from Stephen Hawking that Richard Finemann , introduced the idea that " not one possible reality was possible but that , in the quantum state of affairs " all possible realities must be considered . " I think this is absolutely true in our lives - whether we know it or not .

Following this pattern of thought , I happened to write Izzy about some ideas I had to augment or add to the " Cut - up techniques " using a different approach . She suggested I put it down here , in this forum , so that we could all - check it out and DO the experiment . Ok . So here it is :

My Letter to her . / Hers will follow , promise !

" I needed to study the letter you wrote ( Izzy ) about writing being related to the Quantum reality or principals .This reminded me that , there was at least one language I knew of ... there may be more , ( Hebrew ) , which uses letters and numbers interchangeably . This started me thinking of a process or an idea for an experiment using the following parameters .

1 ) make a selection of (26) numbers out of , lets say (52) possible numbers . They must be chosen at random ... like the " I Ching " coin toss . It doesn't matter what random method you use really .

Ok , once this is done assign ... also at random the " Numbers " to the (26) Alphabet letters . Now we have 26 numbers each - by random choice - assigned to 26 " Letters " .

As in automatic writing a person takes a WSB paragraph \_ or whatever . The selected \_ numbers are now put to the \_letters ; in the paragraph you have chosen , are you with me . Good , he said hopefully . Now the paragraph should not be recognizable ... right ? But does it possibly have other ideas brought out , that you didn't see at first ? This might prove quite interesting . Also one can do the above idea in reverse and start with the ... random generator ... and see what the non- linear world is trying to tell you . I hope its ... fairly ah ... good !

This technique also reminds me of " John Cage's " work , in indeterminacy . He wrote a entirely musical piece based on assigning (64) notes to the I Ching and spent the whole days throwing \_ coins to get the notes ( not -determined ) for his musical piece . Its great by the way . So this – a causal approach using the above method may lead us into very interesting places as it allows non-linear consciousness the room to make manifest and not be disrupted by - conscious thoughts .



This idea was one of the best " defining " tones of the " Beats " ... most of their work including very much of Burroughs , Kerouac and Allen Ginsberg was mostly made by getting in touch with the unconscious or - super -conscious ... mind. This is way their works are as potent today as the day they were written

The idea could be used in the following way as a code writing machine . Like so:

1 ) Agree on lets say 5 - 10 numeric sets... give then numbers like 60 , 61 , 62 , etc.. This makes sure that a message transmitted in ( set say 60 )would be absolute garbage in any other numeric set . Make sense , in other words , one has to have the right code sent and set to decipher it .

2 ) Agree that a letter also stand for a particular language as in ; 70 . = English , 71 = French , 72 = Spanish 73, = Martian etc ..

3 ) Agree on numbers that stand for paragraph breaks and so on as in ; 80 , = period , 81 = Change in paragraph and so on .

4 ) other numbers could define other things .

SO , a whole letter or book or any transmission could be sent -used , with this method .

All these prepositions are a starting point , a departure for this idea. This method as in the traditional , " Cut -Up " technique will often produce mumbled garbled nonsense or possibly a vey new view on something . It doesn't take much for a creative person to " get the feel " of a technique and use it very well, WSB is a excellent example.

If interested lets start experimenting soon and see what happens . There is no right or wrong answers just simply ; actions . I how many will take part and this way I am sure we shall find out perhaps ... much more that we thought .It's time to play " fast and loose " and see what this may furnish us . Do you agree ??

---

# Quantum Writing Generator

## By Amy Balot

<http://callmeburroughs.tripod.com/quantum.html>

<sup>35</sup><sub>17</sub> *Everything is now working.*

<sup>35</sup><sub>17</sub> The Quantum Writing Generator was an idea proposed to the [nova mob](#) yahoo club by jakeroo42. Please visit that club for specific details. After reading his idea, I decided it was a brilliant thing to do, so I have been hell-bent on making a quicker method of the experiment for some time.

<sup>35</sup><sub>17</sub> Based on his jakeroo's ideas, i have made a javascript encoding device with three separate coding systems, called "Naked Lunch," "The Ticket That Exploded," and "Interzone," respectively. To get each code, I read through each of the beginnings of these William Burroughs books, and associated a number with each letter of the alphabet as it appeared. E.g., the first line in *Interzone*, which happens to be "Twilight's Last Gleamings," is "PLEASE IMAGINE AN EXPLOSION ON A SHIP." I took the first word, "please," and associated a number with each character. (P=1, L=2, E=3, A=4, S=5, and "e" has already been accounted for, so it is skipped).

<sup>35</sup><sub>17</sub> The original concept centered mostly on taking text, encoding it, and seeing if it says something else. If that is what you're after, you need not read any further. You can do that by feeding in any text to the machines, as many times as you like, and putting it through all or any combination of the codes. The more text you use, the more likely it will say any besides jumbled garbage. Happy coding.

<sup>35</sup><sub>17</sub> However, the encoding procedure is a bit more (potentially) complicated:

<sup>35</sup><sub>17</sub> First off, after encoding your message, you have to find a way to tell your recipient which code it's in. This could be accomplished in a number of ways. You could either blatantly spell out the code ("nakedlunch"), or each code could be assigned a number or symbol. (nakedlunch=code1). I am thinking of making the machine do this for you, but that's for another day.

<sup>35</sup><sub>17</sub> Also, a number or symbol must be assigned for the language the code is in, in addition to the code system itself (nakedlunch:english) or (1:1).

<sup>35</sup><sub>17</sub> Also, it is my proposal that you should assign a value to another variable, namely, the amount of times it it run through the machine. Since it is not done with paper and scissors, you can easily run a message through a code three or four times. To un-encode it, you would simply run it through the unencoder the same number of times. Example: to tell someone to unencode a message you've written in the "Interzone" code in English, run through the machine three times, you might write: (interzone:english:3).

<sup>35</sup><sub>17</sub> It is also my suggestion that particular symbols would denote a paragraph break, such as the "/" sign. This character could be

programmed to never change, so that paragraph breaks would never be lost in translation.

Anyone wishing to read a more detailed explanation of my coding proposal should click [here](#).

<http://callmeburroughs.tripod.com/quantum/more.html>

<sup>35</sup><sub>17</sub> Now, I will go through the coding and un-encoding process I have proposed earlier:

<sup>35</sup><sub>17</sub> Suppose you want to message someone, using the word "it." (I am keeping it simple to clearly illustrate the principle). You will be writing this code in English, and since you like the stories in the book *Interzone*, you arbitrarily decide you will use that code. And you like the number three, so you will run the message through the encoder three times.

<sup>35</sup><sub>17</sub> In order to tell your friend how to unencode your message, you must present him/her with some information, namely: the code used, the language, and the number of encodings you run through (I will go into detail in a moment). Thus, your message begins like this:

(interzone/english/3)

<sup>35</sup><sub>17</sub> It could be done in other ways, I am thinking it would be better if a number was used to denote the code and language. But for my purposes this works fine. Now, the actual encoding.

<sup>35</sup><sub>17</sub> First, you go to the Interzone Code Page. You type in your message, which in this case example simply reads "it." You then press the button.

<sup>35</sup><sub>17</sub> In the lower box, the encoded message will read "fn." This is only a once-encoded message, and since you want a 3-times encoded message, you need to repeat this process.

<sup>35</sup><sub>17</sub> The second run through, the message reads "zi." You copy and paste the text back into the top box again, press the button, and the final text reads, "uf." At this stage, one would normally mail the message.

<sup>35</sup><sub>17</sub> Now I will illustrate the steps the recipient would go through to read the original message:

<sup>35</sup><sub>17</sub> Since it notes that is it in the *Interzone* code, s/he goes to the *Interzone* code page.

<sup>35</sup><sub>17</sub> S/he copies and pastes the message, beginning AFTER the notes in quotations, into the top textbox and presses the button.

After the first run-through, it reads "zi." The second time, it reads, "fn." Since the message was encoded three times, the recipient would then run it through a third and final time. The message then reads, "it," which was your original message.

35 [explanation http://callmeburroughs.tripod.com/quantum.html](http://callmeburroughs.tripod.com/quantum.html)  
17  
35 [in-depth explanation http://callmeburroughs.tripod.com/quantum/more.html](http://callmeburroughs.tripod.com/quantum/more.html)  
17  
35 [naked lunch coder http://callmeburroughs.tripod.com/quantum/nl1.html](http://callmeburroughs.tripod.com/quantum/nl1.html)  
17  
35 [naked lunch decoder http://callmeburroughs.tripod.com/quantum/nl2.html](http://callmeburroughs.tripod.com/quantum/nl2.html)  
17  
35 [ticket that exploded coder http://callmeburroughs.tripod.com/quantum/ticket2.html](http://callmeburroughs.tripod.com/quantum/ticket2.html)  
17  
35 [ticket that exploded decoder http://callmeburroughs.tripod.com/quantum/ticket2.html](http://callmeburroughs.tripod.com/quantum/ticket2.html)  
17  
35 [interzone coder http://callmeburroughs.tripod.com/quantum/zone1.html](http://callmeburroughs.tripod.com/quantum/zone1.html)  
17  
35 [interzone decoder http://callmeburroughs.tripod.com/quantum/zone2.html](http://callmeburroughs.tripod.com/quantum/zone2.html)  
17  
35 [email amybalot@hotmail.com](mailto:amybalot@hotmail.com)  
17

# Juanjo Patanegra

## THE QUANTUM SHE-CAT (I)

### THE QUANTUM SHE-CAT (I)

[Juanjo Patanegra](http://patanegra.pitas.com/)

<http://patanegra.pitas.com/>

14-6-01 [ Version 2,1 ]

If our bodies are our determined component more subject to "hard laws" like the one of the gravity, the physical and physiological base for the human experience and the bio-holographic process of consciousness/energy is however the quantum uncertainty.

In the case of the psychedelic experience, our conscience and cellular body are put under "soft laws", reason why such uncertainty is harnessed until kissing extreme, beyond which, the limits imposed by the cultural agreements could be transferred, that not neurochemicals.

The arrival of the psychedelic agent to the cerebral system introduces a factor of imbalance in the mental order imposed by the prevailing dictatorship of the perception, and the subjection to the "hard laws" of the three-dimensional physics can be debilitated due to a crossing of being able to the "soft laws", or to the vertiginous entrance in the free and quantum territory, beyond any law. That after the psychedelic process the bio-cerebral system unstably becomes stabilized, after the laborious return of the "free invisible republic", be in a new order, state of greater complexity, that is, like alternating possibility, that crystallizes the unbalance

### LA PSICONÁUTICA GATA CUÁNTICA (I)

[Juanjo Patanegra](http://patanegra.pitas.com/)

<http://patanegra.pitas.com/>

14-6-01 [Versión 2.1]

Si nuestros cuerpos son nuestro componente más determinado, sujetos a "leyes duras" como la de la gravedad, la base física y fisiológica para la experiencia humana y el proceso bio-holográfico de la conciencia/energía es en cambio la incertidumbre cuántica.

En el caso de la experiencia psiquedélica, nuestra conciencia y cuerpo celular se halla sometido a "leyes blandas", por lo que tal incertidumbre es potenciada hasta besar extremos, más allá de los cuales, podrían ser traspasados los límites impuestos por los condicionamientos culturales, que no neuroquímicos.

La llegada del agente psiquedélico al sistema cerebral introduce un factor de desequilibrio en el orden mental impuesto por la imperante dictadura de la percepción, y la sujeción a las "leyes duras" de la física tridimensional puede debilitarse debido a un traspaso de poder a las "leyes blandas", o a la entrada vertiginosa en el territorio libre y cuántico "más allá de la leyes".

Que tras el proceso psiquedélico el sistema bio-cerebral inestablemente se estabilice, tras el penoso regreso de la "libre república invisible", sea en un nuevo orden, estado de mayor complejidad, o sea, como posibilidad alterna, que cristalice el desequilibrio estabilizándose el caos, depende de

becoming stabilized the chaos, it depends on factors neither certain, nor possibly definibles.

We know that the functions of quantum wave cannot be defined, as it happens with the hackneyed Schrödinger's cat, that already until a boygirl knows that it is neither alive nor dead, because like good quantum cat, is simultaneously alive and dead. There is a joint possibility to be anyone of the two things: as from them it gets to occur is something, beforehand, indetermined.

In a three-dimensional cultural dimension like ours, reasonably we are defined; nevertheless, the introduction of a psychedelic agent in our system entails even an increase of the possibilities of indetermination, and therefore, of liberation of several restrictions. Simultaneously they increase the possibilities that the collective hallucination acquires monstrous dimensions subjectively and to the altered conscience [alter=other] the walls of the prison seems to hir still wider, in a situation of "no exit, disappearance of the door" in the invisible walls of the false mental jail. And it is question of the point of perception of a same Reality, because if before hallucinated psyche/cosmonaut it does not appear door some is because there is really walls nor no jail beyond our imaginary social group.

Due to its quantum imprevisibilidad, the chemical catalyst can submerge to us in the emotional vital pool or the pre/rational marsh, maintaining to "our grief", splashing about desperated in them until the effects send; perhaps it can also take us to the border edges of the rationality, oscillating between harnessed self-referential mental networks and "land of anybody" of the indefinable crossing of the flexible and diffuse borders after which more complexes exist -- and nevertheless subtle -- kingdoms of the energy/consciousness.

Perhaps also emergent and catalytic original sound OM added to already the effective

Sabemos que las funciones de onda cuántica no pueden definirse, como ocurre con el manoseado gato de Schrödinger, que ya hasta un niño sabe que no está ni vivo ni muerto, porque como buen gato cuántico, está simultáneamente vivo y muerto. Hay una posibilidad conjunta de ser cualquiera de las dos cosas: cual de ellas llegue a darse es algo, de antemano, indeterminado.

En una dimensión cultural tridimensional como la nuestra, estamos razonablemente definidos; sin embargo, la introducción de un agente psiquedélico en nuestro sistema conlleva parejo un aumento de las posibilidades de indeterminación, y por tanto, de liberación de constreñimientos varios. Simultáneamente aumentan las posibilidades de que la alucinación colectiva adquiera subjetivamente dimensiones monstruosas y a la conciencia alterada [alter=otro] los muros de la prisión le parezcan aún mayores, en una situación de "no salida", de "desaparición de la puerta" en los muros invisibles de la ilusoria cárcel mental. Y es cuestión del punto de percepción de una misma Realidad, pues si ante el psiconauta alucinado no aparece puerta alguna es porque no hay realmente paredes ni cárcel más allá de nuestro imaginario social colectivo.

Debido a su imprevisibilidad cuántica, el catalizador químico nos puede sumergir en el charco vital emocional o en el pantano pre/racional, manteniéndonos "a nuestro pesar" chapoteando desesperados en ellos hasta que los efectos remiten; acaso pueda también llevarnos a los bordes fronterizos de la racionalidad, oscilando entre potenciadas redes mentales auto-referenciales y la "tierra de nadie" del indefinible cruce de las fronteras flexibles y difusas tras las cuales existen más complejos --y sin embargo sutiles-- reinos de la energía/conciencia.

Acaso también el emergente y catalizador sonido original OM sumado al ya efectivo agente bio-químico podría hacernos traspasar esas fronteras imprecisas, dejándonos llevar más allá de nuestros procesos usuales de pensamiento.

biochemical agent could make us transfer those imprecise & vague borders, letting take to us beyond our usual processes of thought. In this indefinite, tiny point and cuasi infinitely narrow footpath, a adimensional or transdimensional qualitative jump would take place in which any psyche/cosmonaut -- or yogui with its conscience like force and its body like laboratory --, like effect of the yearning of a dissatisfied soul, of the loss of the fear to the stranger and the delivery to the liberating process, is transformed in a quantum cat, or a quantum she-cat, if it is that it has or some sense to speak of the original genre, because we are or before the transexual presence of (s)he-cats.

If the novel cerebral waves generated beyond the borders they turn [formerly to us had been said: by magic art] in functions of indetermine quantum wave, we are "here" and "there" simultaneously, at the same time we are in our body and we are not it: to all the effects, in the three-dimensional world we are alive and dead. The psychedelic experience can carry, like one of its variable and multiple possibilities, degrees of reality and unreality.

[The ingestion of the psychedelic agent is equivalent novel to the effect of the observer who determines, in this case, the state bases from which paradoxically to enter -- the liberating exit of the determination.]

Thus it is conceived because the possible process range:  $x \rightarrow$  old determination  $\rightarrow$   $h \rightarrow$  new determination  $\rightarrow$   $om \rightarrow$  adetermination=liberation.

If we observed with flexibility the content of our minds from which we can get to be conscious, we will be able to notice the ample unfolding of multiple and multiplied thoughts, coming from "outside", flowing "without order nor concert" and/or from "inside", in a precise and deep order; in such a way that from the position of the Witness we are in disposition to perceive wide of phantom of possible thoughts. We spoke of

En este punto indefinido, diminuto y cuasi infinito, "el estrecho sendero", se produciría un salto cualitativo adimensional o transdimensional en el que psiconauta --o yogui con su conciencia como fuerza y su cuerpo como laboratorio--, como efecto del anhelo de un alma insatisfecha, de la pérdida del miedo a lo desconocido y de la entrega al proceso liberador, se transforma en un gato cuántico, o en una gata cuántica, si es que tiene ya algún sentido hablar del género original, pues estamos ya ante la presencia de gatxs transexuales.

Si las novedosas ondas cerebrales generadas "más allá de las fronteras" nos convierten [antiguamente se hubiera dicho: "como por arte de magia"] en funciones de onda cuántica indeterminada, estamos "aquí" y "allí" simultáneamente, al mismo tiempo estamos en nuestro cuerpo y no lo estamos: a todos los efectos, en el mundo tridimensional estamos vivos y muertos.

La experiencia psiquedélica puede acarrear, como una de sus posibilidades, grados variables y múltiples de realidad e irrealidad.

[La ingesta del agente psiquedélico equivale al efecto del observador que determina, en este caso novedosamente, el estado base desde el que entrar -paradójicamente-- en la salida liberadora de la determinación.]

Así se concibe pues el recorrido del proceso posible:

$x \rightarrow$  vieja determinación  $\rightarrow$   $h \rightarrow$  nueva determinación  $\rightarrow$   $om \rightarrow$  adeterminación=liberación.

Si observamos con flexibilidad el contenido de nuestras mentes del que podemos llegar a ser conscientes, seremos capaces de advertir el amplio despliegue de pensamientos múltiples y multiplicados, viniendo de "fuera", fluyendo "sin orden ni concierto" y/o de "dentro", en un orden preciso y profundo; de tal modo que desde la posición del Testigo estamos en disposición de percibir "el ancho de espectro de pensamientos posibles". Hablamos de áreas fronterizas de conciencia, del "crepúsculo de la mente" al que aludieron los poetas y visionarios; hablamos de zonas en cualquier momento accesibles, con

border areas of conscience "twilight of the mind" to that the poets and visionaries alluded; we spoke at any time of accessible zones, with chemical agents or without them. Its reality is not material, if by matter we considered solely to the matter well-known and measured by academic science, but it is perhaps the new matter, of a lightness, power and subtle & supreme plasticness.

Note I: in origin female psychonaut, the quantum she-cat, has an extra at the time of knowing this new matter, has a greater facility of reception of the subtlest energies due to its greater permeability this new energy/consciousness, because generally its capacity of delivery and to orgasm is greater than the one of the male psychonaut.

Note II: Let us remember the equivalence of energy and matter. Therefore if we spoke of a new matter, we do it, coincidentally, of a new energy, and still we would say, of a new conscience.

Note III: Let us wait for of Einstein II the new equation.

The unreal thing only is it in ours limited vision of the world. When increasing wide of vision, the conscience, energy and experience, we perceived that in the world, our world, there are unknown frequencies, and edges beyond which, without letting be here, we are there, expressing our soul with fullness. And "here/always" we arrived more completely at living/us, like some poets, in its world of the really creative imagination, long ago dreamed.

agentes químicos o sin ellos.

Su realidad no es material, si por materia únicamente consideramos a la materia conocida y medida por la ciencia académica, mas se trata acaso de la nueva materia, de una ligereza, potencia y "plasticidad sutil" suprema.

Nota I: la en origen psiconauta hembra, la gata cuántica, dispone de un plus a la hora de conocer esta nueva materia, dispone de una mayor facilidad de recepción de las energías más sutiles debido a su mayor permeabilidad a esta nueva energía/conciencia, pues por lo general su capacidad de entrega y de orgasmar es mayor que la del macho psiconauta.

Nota II: Recordemos la equivalencia de energía y materia. Por tanto si hablamos de una nueva materia, lo hacemos, coincidentemente, de una nueva energía, y aún diríamos, de una nueva conciencia.

Nota III: Esperemos de Einstein II la nueva ecuación.

Lo irreal sólo lo es en nuestra limitada visión del mundo. Al aumentar el ancho de visión, conciencia, energía y experiencia, percibimos que en el mundo, nuestro mundo, hay frecuencias desconocidas, y bordes más allá de los cuales, sin dejar de estar aquí, estamos allí, expresándose nuestra alma con plenitud."Allí/aquí" y "ahora/siempre" llegamos a vivir/nos más completamente, como algunos poetas, en su mundo de la imaginación realmente creadora, antaño soñaron.



# Planos para una maquina de conferencia triple

Daniel Gualda

Propongo un nuevo artefacto, en realidad, la reutilización de equipamiento existente, reorganizado con una nueva función, que, como veremos mas adelante posiblemente tenga solo utilidad imaginaria, teórica o virtual.

Tres emisores-receptores tendrían una conferencia de audio desfasada. "A" le hablaría a "B" y este a "C" y este a la vez a "A".

Materiales: tres micrófonos,tres auriculares, cuatro habitaciones aisladas acústicamente, tres etapas de amplificación con entrada/salida.

Modo de uso: los tres emisores-receptores si instalarían cada uno en una habitación aislada con su correspondiente micrófono y auriculares. Los cableados de estos se conectarían con tres etapas de amplificación en una cuarto habitación. La conexión a los amplificadores tendría que respetar el siguiente esquema:

Amplificador 1 -> se alimenta de A

-> envía a B

Amplificador 2 -> se alimenta de B

-> envía a C

Amplificador 3 -> se alimenta de C

-> envía a A

Especulaciones: (el planteo teórico de la maquina constituye la primer especulación!) Teorizando acerca de la organización de la

3c(C) (conferencia triple) se comentó que el primer problema a resolver es el del "ruido". Es, a mi entender, una visión pesimista. La 3c(C) fue diseñada precisamente para eliminar el "ruido" de una conferencia normal de tres integrantes.

El vuelco (dump) , la necesidad del vuelco, tiende a chocar con otros vuelcos, ese es el verdadero "ruido", la interrupción!.

Imaginemos cual colegas prestos a una composición "tema libre"

como se derrollaría una conferencia entre tres conocidos.

A: -Para empezar tomemos un tema cualquiera, algo anecdótico por ejemplo.

B: -Que pesado!, seguro que vas a contar alguna de esas anéctodas que contas siempre.

C: -Pesado yo?, vos por que no te acordás cuando contaste cinco veces lo mismo la misma noche.

En la situación A,B y C estaban en silencio y A comenzó a hablar,

podrían haber sido B o C y el resultado seria similar. Cuando la

comunicación vuelve a A se pueden producir dos situaciones básicas:

1: A lo escucha a C y tiene conciencia de que hubo un fragmento perdido (lo que dijo B), e intenta reconstruirlo mentalmente

para a su vez decirle algo (esto siempre que este realmente conciente de que le habla a B y no a C, que sería su interlocutor natural).

2: A ciegamente responde a C, o lo ignora y continua con su planteo original.

Situaciones excepcionales:

Si bien el momento de la aparición en conferencia de los agentes nunca

es exactamente el mismo, existe la posibilidad de que sea bastante cercano.

Esta superposición tendría consecuencias imprevistas.

Se ignoran los resultados posibles entre tres agentes desconocidos.

Otras variantes como dos conocidos y un desconocido se descartaron hasta la fecha como objeto de estudio. Implementado el 3c(C) se estudiaran en profundidad los resultados obtenidos en cualquier situación posible.

Este informe carece inicialmente de utilidad práctica, no es una invitación a concretar las ideas expuestas, "lo importante es no salir del plano teórico", es simplemente un informe, que no requiere respuesta alguna, que no cree que la merezca, y que solo solicita en su calidad de tal el correspondiente archivo.

---

# SPACE TRAVEL

## Joshua Berlow

### *Joshua Berlow's Website*

Burroughs (William S.) said that for us to be taking air in capsules out in space was akin to fish taking water with them when they left the sea for the land... in other words, Burroughs was saying that for true space travel to happen, we will have to have some sort of significant evolutionary leap that will enable us to be comfortable in space.

Further, somehow this evolutionary leap is facilitated by mind-altering drugs... we'll travel in space without our physical bodies... in some sort of mental fashion. In fact, Burroughs says that there are two basic opposing forces in earth history... there is the anti-space travel side and the pro-space travel side. The aliens are already here... there are Good Aliens and Bad Aliens (The Nova Police- "No Va" being Spanish for "Can't Go") . The bad aliens are doing everything they can to hamper us Earthings from getting out into space, and the War on Drugs is part of the conspiracy to prevent us from getting out into space. Also, the space program as we know it today is a waste of time, a blind alley, and that nothing will be accomplished as long as we insist on trying to take air with us out into space. It's part of the bad alien conspiracy to hamper the evolutionary leap.

---

# THE EXTRACORPOREAL EFFECTS OF BIOACTIVE SUBSTANCES

Allan J. Cronin

October 10<sup>th</sup> 1998

Attached is a brief monograph on concept with which I've pondered for some time. It was originally submitted to MAPS (Multidisciplinary Association for Psychedelic Studies) discussion group where it was poorly received. I still maintain that these concepts have merit and are researchable. After your most recent "report from Paris" it occurred to me that I should make this available to you and Western Lands. I hope you find it interesting.

Subject: Extracorporeal Effects of Bioactive Substances

Date: Monday, August 10, 1998 6:37 PM

The following monograph is submitted for review and commentary. It is intended as a precursor to a larger paper on this subject.

---

## **THE EXTRACORPOREAL EFFECTS OF BIOACTIVE SUBSTANCES, A PROPOSAL**

**by Frances Gerard**

[allan.cronin@gmail.com](mailto:allan.cronin@gmail.com)

With his assertion that "...the map is not the territory" Alfred Korzybski(1) showed the potential for making incorrect assumptions based on the logical error of taking the theory (map) as being a wholly accurate representation of how a given system functions. Current pharmacological theories describe mechanisms of action by which a given bioactive substance acts to cause physiological changes in an individual organism. But speculative fiction (2) and progressive theoretical writings (3, 4) suggest the possibility that there are actions exerted by bioactive substances which extend beyond the individual organism and for which causative mechanisms have yet to be proposed.

There are observable phenomena which occur outside of a given subject organism which occur in correlation with the administration of a bioactive substance which has a demonstrable effect on the subject. One such example is the calming effect on the unit staff and/or the family of a psychiatric patient who has received a medication which results in a calming of that individual's agitation or anxiety. The staff and/or the patient's family will also report feeling calmer as well. And, while a direct causative mechanism has not yet been described, the phenomenon is well known and easily replicated. This would presumably make it researchable.

Another well known phenomena which is frequently seen in health care news is that of "antibiotic resistance". Continued use of antibiotic therapy for infections in individuals is resulting in many strains of "antibiotic resistant" organisms (Methicillin Resistant Staph. Aureus and Vancomycin Resistant Enterococci are well known in hospital settings). For this phenomena two mechanisms have been described: 1) natural selection in which the organism with the capacity to neutralize a given antibiotic survives while those without that capacity succumb to the agent and 2) environmental transfer of genetic material which confers the trait of resistance in which the

DNA/RNA containing the trait are transmitted to cells which did not already have the trait via the environment in which they exist.

Yet another phenomena as well known is that of the social and psychological reactions to the introduction, use (and abuse) of many bioactive substances. Reactions to birth control pills and abortifacients such as RU-486 are part of the historical record. The introduction of major tranquilizers, anti-depressants and mood regulating drugs have vastly changed the practice of psychiatry in a manner similar to Dr. Lister's introduction of phenol changing the thinking and practice in medicine and surgery.

The lack of theory to describe causative mechanisms for concurrent effects frequently results in the dismissal of the phenomenon or at least dismissal of the possibility of a causative connection (correlation does not equal causation). But this is the logical error against which Korzybski warns. I am proposing the researching of possible causative mechanisms for the action of substances outside of the subject. These "extracorporeal effects" might well be used to suggest mechanisms by which substances exert effects on theoretical entities such as the "collective unconscious" or the "overmind" rendering these theoretical entities more validity and demystifying otherwise unexplainable phenomena.

Terrence McKenna alludes to such phenomena in "True Hallucinations" where he suggests mechanisms such as ESR (electron spin resonance) and possible links to DNA to explain the psychic effects of his experiments with psilocybin and harmaline.

Timothy Leary postulated eight "neural circuits" (5) and Stanislav Grof suggests the "Basic Perinatal Matrices" (6) to explain psychedelic phenomena they have observed.

Rupert Sheldrake (4) has elucidated the theory of "morphogenetic fields" to describe extracorporeal or intercorporeal mechanisms of learning.

I am suggesting that non-psychoactive substances are also subject to these or similar phenomena and that psychedelic research has opened this area of inquiry.

#### Notes

1. Korzybski, A. (1973) Science and sanity. 4th ed. Clinton, MA: Colonial Press.
2. Dick, P.K. (1974) Flow my tears, the policeman said. New York: Donald A. Wollheim.
3. McKenna, T. (1993) True hallucinations. New York: Harper Collins/Harper San Francisco.
4. Sheldrake, R. (1981) A new science of life: the hypothesis of formative causation. London: Blond and Briggs
5. Leary, T. (1982) Changing my mind, among others. New Jersey: Prentice-Hall, Inc..
6. Grof, S. (1985) Beyond the brain. Albany: State University of New York.

# **Pain, Death and LSD:**

## ***A Retrospective of the Work of Dr. Eric Kast***

By  
[Allan J. Cronin](#), RN, BSN, BA

This paper was first published in *Psychedelic Monographs and Essays Volume 5* (1990) edited by the late Thomas Lyttle. It was published under a pseudonym. The author hopes that it's reprinting will bring the work of Dr. Kast to a larger audience.

LSD is perhaps best known for its role in the psychedelic subcultures of the 1960's. There exists, however, a lesser known but extensive literature reporting investigations of the drug's medical therapeutic potentials. This, the first in a series of articles retrospectively examining the work of some all-but-forgotten researcher, will focus on the work of Eric C. Kast, M.D.

Born in Vienna, Austria in 1916, he and his family converted to Catholicism in 1935. They fled to the United States after the Nazi invasion of Austria in 1938. He completed his M.D. at Loyola University Medical School in Chicago in 1944 having interned at Michael Reese Hospital and completed residencies in both medicine and psychiatry at the University of Chicago Clinics, Permanente Foundation Hospital in Oakland, California and Manteno Hospital in Illinois. Dr. Kast was a teaching fellow at Tufts Medical College and is a member of Sigma Xi.

With staff appointments at Cook County Hospital, Mt.Sinai Hospital Department of Medicine, Michael Reese Hospital, Hektoen Institute for Medical Research as well as Clinical Assistant Professorships in both medicine and psychiatry at Chicago Medical School, Dr. Kast also maintained an outpatient practice at his downtown Chicago office.

The earliest publication I was able to find (Kast, 1962) is an attempt to define a method for measuring the elusive concept of pain and responses to analgesics. He differentiates between "pathologic pain" related to a disease process and "experimental pain" induced by a mechanical apparatus. The patients in the study controlled the pain inducing apparatus and were instructed to increase the experimental pain to a level that they felt equaled their pathologic pain. The level of pneumatic pressure required of the device to induce experimental pain was used as an objective indicator of the pathological pain.

Various analgesic drugs and a placebo were assessed for the degree to which they produced pain relief. Objective data are presented on the efficacy of the drugs versus placebo.

In this study, which precedes his experiments with LSD, Dr. Kast advances an interesting theoretical idea about pain. He notes that the subjects' experience of experimental pain was not affected by analgesics while pathologic pain was relieved. The explanation he offers is that pathologic pain has both a sensory (physical) aspect and an affective (emotional) aspect while experimental pain (controlled by the subject) has only a sensory aspect.

To explain the action of the analgesic drugs he suggests that they induce a "feeling of removal of the self from emotional problems," allowing the subject to distance themselves from the painful part of the body while maintaining a sense of bodily integrity. He cites a psychoanalytic article (Ramzy

and Wallerstein, 1958) which states that narcotics produce “a feeling of grandeur and spiritual expansion at the expense of bodily feelings and concerns.” Dr. Kast suggests that this may also apply to other intoxicating agents and non-narcotic analgesics. Foundational methodology for this work is detailed in two previous articles (Kast and Loesch, 1959 and Kast and Loesch, 1961).

The medical model approach to research is evident in Kast’s first report on the use of LSD (Kast and Collins, 1964a) is a comparison of the duration of analgesia produced by meperidine (Demerol), dihydromorphinone (Dilaudid), and LSD-25 in gravely ill and terminal patients. Their conclusion was that LSD-25, while slower in onset, produced greater and longer lasting pain relief than either of the narcotics. Also noted was the fact that 8 of the 50 patients refused further administration of LSD, 30 patients were indifferent and only 12 patients wished to experience the drug again even though all experienced significant pain relief.

Two mechanisms are proposed to explain LSD’s analgesic effect: “...certain obliterations of the ego boundaries (permitting) sequestration of the diseased part...alleviating pain affect” and “...LSD-25 produces an inability to maintain selective attention on a sensation of importance (which) should alleviate both components of the pain experience.”

In an article which first appeared in David Solomon’s well-known anthology “LSD: The Consciousness Expanding Drug” (Kast, 1964b) and subsequently revised (Kast, 1967a), a study of single dose administration of LSD 100mcg to 128 “preterminal” cancer patients at Chicago’s Cook County Hospital is described.

Four factors are proposed as mechanisms to explain the analgesic potential of LSD:

1. “(LSD) seems to deprive the patient of his ability to concentrate on one specific sensory input, even if the input is of urgent survival value.”;
2. “...’minor’ sensations, namely those of less importance for survival, make a claim on the patient’s attention sometimes in preference to those of major survival significance.”;
3. “(LSD) diminishes cortical control of thought, concepts, or ideas and reduces their significance in control of vegetative function and behavior in general. The meaning of pain...and its frightful resonance...is greatly alleviated.”; and
4. “...LSD obliterates the individual ego’s boundaries (and) a geographic separation can more easily be made between the self and the ailing part.”

These same factors are used to support a further elaboration, the theory of “attenuation of anticipation” in which the author suggests that LSD allows the patient to escape the anticipation of pain by making immediate sensory input relatively more important.

The results of the study showed a precipitous drop in pain about two to three hours after administration of the 100mcg dose of LSD. Pain relief lasted an average of 12 hours despite the fact that no other analgesics were given during this period. And total pain intensity was reported to be less for up to three weeks thereafter.

Patients’ general mood was reported to be elevated, “almost euphoric” , for 11 to 12 hours after which their moods returned to baseline. Curiously, some patients seemed unconcerned about their impending death and they experienced more restful sleep for up to ten days. But the concerns about their condition and inability to sleep did eventually return.

Only 10% of the patients reported hallucinations but 50% reported visual distortions. Panic reactions were seen in 7 patients (5.5%) and 42 (33%) suffered mild anxiety reactions. All reactions responded to follow up psychotherapy and, most notably, no medical complications occurred.

Another paper which was published in the *Chicago Medical School Quarterly* (Kast, 1966a) is apparently a discussion of the same clinical trial. It does not specifically refer to the location of the trial and the fact that the chapter in Solomon's 1964 book is not cited in the bibliography suggests that this paper is offered specifically to the academic community.

In view of Dr. Kast's principal role as a clinician and the impending constraints resulting in the termination of most LSD research in humans, it is not surprising that he conducted no further work with LSD. Two papers which appeared in 1966 (Kast and Collins, 1966b; Kast, 1966c) are only slightly different versions of the authors' research on a new analgesic agent, methotrimeprazine (Levoprome), a non-narcotic analgesic which can still be found in clinical use. The basic theoretical framework for pain assessment remains intact but there is clearly a shift to more concrete clinical research with substances whose pharmacology is better understood and whose actions are thought to be desirable in these terms. (1)

Interest in social and political issues is the dominant theme in the remainder of Kast's published output, (Kast, 1966d, 1967b, 1972, 1973, 1974, 1976). He published on the subject of LSD again only once (Kast, 1970) integrating social/political concerns in describing the impact of LSD on the concept of death. While he cites more radical, non-academicians such as Che Guevara and Aldous Huxley, the article remains a sound discussion of the possible benefits of LSD in terminal patients.

Dr. Kast's obituary (Heise, 1988) describes him as, "...deeply Catholic, proudly Jewish and militantly Marxist." Until his death from cancer on November 26, 1988 he was active in establishing three free health clinics in Chicago's poverty stricken neighborhoods. At one point in 1969 he worked with the radical Black Panthers to establish one of these clinics.

In a 1985 article (Kurland, 1985) Kast's research is prominently cited and describes four cases histories not unlike those described by Kast in which 100mcg of LSD was administered to cancer patients with variable but, at times, positive results.

At the time Dr. Kurland, a psychiatrist with the National Institute of Mental Health, was the only person licensed to administer LSD to human subjects in the United States. His conclusion is that good reasons remain to pursue research with LSD in the terminally ill.

#### Notes

1. The pharmacology of LSD and the mechanism(s) of action remain poorly understood.

#### **Bibliography**

Heise, Kenan. (1988, December). Dr. Eric C. Kast, 72; Ran Free Health Clinic, Chicago Tribune.

Kast, E.C. and Loesch, John. (1959). "A Contribution to the Methodology of Clinical Appraisal of Drug Action" *Psychosomatic Medicine* 21 (3): 228-234

Kast, E.C. and Loesch, John (1961). "Influence of the Doctor-Patient Relationship on Drug Action. *Illinois Medical Journal* (119): 390-393.



Kast, E.C. (1962). "The Measurement of Pain: A New Approach to an Old Problem." *Journal of New Drugs* 2: 344-351.

Kast, E.C. (1963). "The Analgesic Action of Lysergic Acid Compared with Dihydromorphinone and Meperidine." *Bulletin on Drug Addiction and Narcotics*. Vol 27 (Appendix): 3517-3529.

Kast, E.C. and Collins, V.J. (1964). "A Study of Lysergic Acid Diethylamide as an Analgesic Agent." *Anesthesia and Analgesia*. 43: 285-291

Kast, E.C. (1964). "Pain and LSD-25: A Theory of Attenuation of Anticipation." In D.Solomon (Ed.), *LSD: The Consciousness Expanding Drug*. (pp. 241-256) New York: G.P. Putnam and Sons.

Kast, E.C. (1966a). "LSD and the dying Patient." *Chicago Medical School Quarterly*. 26:80-87.

Kast, E.C. and Collins, V.J. (1966b). "A Theory of Human Pathologic Pain and Its Measurement: The Analgesic Activity of Methotrimeprazine." *Journal of New Drugs*. 6: 142-148.

Kast, E.C. (1966c). "An Understanding of Pain and Its Measurement." *Medical Times*. 95 (12): 1501-1513.

Kast, E.C. (1966d). "The Predicament of the Aged." *Illinois Medical Journal*. 129 (2): 132-136.

Kast, E.C. (1967a). "Attenuation of Anticipation: A Therapeutic Use of Lysergic Acid Diethylamide." *Psychiatric Quarterly*. 41 (4): 646-657.

Kast, E.C. (1967b). "A Limited Discussion of the Treatment of Parkinson's Disease." *Diseases of the Nervous System*. 28 (10): 684-685.

Kast, E.C. (1970). "A Concept of Death." In B. Aaronson and H. Osmond (Eds.), *Psychedelics: The Uses and Implications of Hallucinogenic Drugs*. New York: Anchor Books, Doubleday and Co., Inc.

Kast, E.C. (1972). "On Being Old and Dying." *Journal of the American Geriatrics Society*. 20 (11): 524-530.

Kast, E.C. (1973). Letter: A Sense of Direction. *Lancet* 2 (820): 105.

Kast, E.C. (1974). Letter: Health Care in South Africa. *Lancet* 1 (847): 95-96.

Kast, E.C. (1976). Letter: Treatment of Alcoholism. *Journal of the American Medical Association*. 236 (12): 1352-1353.

Kurland, A. (1985). "LSD in the Supportive Care of the Terminally Ill Patient." *Journal of Psychoactive Drugs*. 17 (4): 279-290.

Ramzy, I. and Wallerstein, S. (1958). "Pain, Fear and Anxiety: A Study in Their Interrelationships." *Psychoanalytic Study of the Child*. 13:147.

The author wishes to thank the staff and research facilities of Rush University, the University of Illinois at Chicago, the Chicago Medical School and the Chicago Public Library acknowledging their kind assistance in the preparation of this paper.

# Nova Terata : Stripping Away the Flesh

By Terata

The oppressive concrete island encapsulates reality for those who are unfortunate enough to be trapped inside the shores of that oily sea, the Gulf of Mexico. Ameko, the Rain Child, stares into the night sky in hope that one of the stars will fall next to her. Only a star could offer her the love she needs right now; to be enveloped in the atom mother's heart. People assume that mutilation of the flesh is a sign of self-destruction not considering the possibility that the flesh is not what constitutes the person. Ameko shifts her attention from the starry sky to her wetwired memory allocation. I call out to her through the ether. I escaped a year or two ago, but only after I cleaned out many ghosts in my shell. Movement always happens across many planes. In order to move from this place, I had to move from everything this place made of me. Ameko is my only connection left, but I guess I would willingly be reminded of this inferno if it meant touching her without the thought, "This is the last time. After this, she does not exist." I refuse to let my friends become nothing more than static memory that could disappear anytime during a defragmenting.

The ambient terabits of Christ's bloody teardrops fills the air with the smell of fish and saltwater like so much religious data trash and the sky with red ozone glow. Corpus Christi is a wounded city like Galveston and every other Hurricane plagued Babel. Everybody here is lost and speaks without understanding their neighbors. The one way out is the arching Harbor Bridge, and the only way off the Bridge is to jump onto a passing barge. Maybe if you are lucky, the barge will not head further south. This might seem like an exaggeration to all but the desperate, but plenty victims of desperation see my perspective in parallel and leap off that steel relic into the soapy brine below. The fringe of the city is the best place to paint in Ameko's opinion. Fringes are always paradoxes because sub-atomic particles never really touch, and paradoxes are what keep the sub-conscience in perpetual motion. In addition, an undeniable eroticism comes from being so near infinity, which could be cosmic satisfaction. Only art satisfies Ameko. She paints her emotional reactions to the masturbatorial stimulation she receives when she concentrates on the fringe. Everything she paints is beautiful. I sell some of her work in galleries in New York, Milan, Paris, and Toronto. I send her all the credits, so she no longer has to resort to what occupation Corpus offers for a beautiful ripe young woman like herself.

Years have passed since the Global Village attempted to save the lost causes trapped inside these conservative districts, but mass retaliation from the religious right and the dysfunctional Corpus Christian pop culture ended all hope of even virtual freedom from the oppressive hands of this patriarchal society. The entire economy is built on the exploitation of women and the social activities that lead to that exploitation. Thousands of lonely men enlist here and live in a huge naval base that greatly expanded after Fascist Cuba invaded Haiti and war broke out between Cuba and the Dominican Republic. The war ended long ago as well, but the tension remains.

To provide entertainment for the estranged soldiers, at least a hundred strip bars or gentlemen's clubs have been built along the freeway and mainstreets. The credits are great at these oracles of fetish. The men come in with half their paychecks from shrimping, fishing, or industrial work. They slide their credit cards through the slots the dancers wear on the taboo areas of their person. The filth still are not allowed to touch the merchandise, but the dancers have to bend over or crawl over closer to the men in order for the cards to access the slots. Some of the audience members start coming here before they graduate from middle school. Some of the dancers do too.

A young cute Asian girl approaches the stage from behind a screen showing flashing montages of pop media. Aquamarine light floods the stage and audience. Jungle music fades into hip-hop into trip-hop into trance into trip-hop into trance again. Ameko twirls onto the middle of the stage covered in a gossamer gown of hologram silk. Images of light flow from the gown and enter the minds of the onlookers. Everyone sees a different image in the hologram, but whatever iridescent dazzle the audience sees in the shimmering gown mockingly hides the forbidden flesh. As hard as a viewer may squint, they will never see Ameko's naked flesh as long as that gown drapes her sensual frame. The music intensifies as Ameko slowly walks around the stage toward the audience. Approaching the catwalk, the light begins to dim into darkness. Hoots and hollers radiate from the crowd at this point. Apparently, this routine is familiar enough with some of the "gentlemen". A robotic claw of some kind lowers from the ceiling and rapidly pulls the gown from the temptress's crouched body then retracts into the air. Instantly three things happen. A strobe begins to pulsate so rapidly that everything appears to move very slowly. A shower of water begins to pour from the ceiling onto Ameko and the stage. The trance music fades into a cover of "Sour Times" by Portishead.

Ameko stands up to reveal everything but her breasts and pubic area. She is wearing a silken bikini of the same holographic material as the gown. The cold water pours all over her hair and flesh as she moves with grace and perfection. Her breasts harden and her muscles tighten under the cold water. Goosebumps cover her flesh from shoulder to foot. The credit slot becomes visible along the small of her back. The crowd grows anxious to slide their sweaty credit cards through the slot so cleverly placed. Ameko grabs the dancing pole on the center of the stage and begins to caress it and press up against it. The symbolic phallus slides easily across the valley between her veiled breasts and buttocks teasing the crowd with the ridiculous possibility that this could happen to them one day.

The relationship between spectator and object d'art twists space and time when the object is a living thing of equal or greater consciousness. Unlike in a physical relationship, the object controls the spectator. The dancer cannot be disturbed or interrupted by the pathetic men. The men can display their desire in the form of remarks or their credits, but there is an understanding that the dancer will only dance and eventually disappear. The nature of the arrangement depends on each unique perspective. A dancer can feel shame in what she does, or pride in her power over men's desire. An even more common perspective is the simple apathy that comes with desensitization or heavy drugs use.

Ameko only danced for three months before she began to paint. The whole experience was more or less an attempt to discover the intensities of her sexual self. She had always repressed that most tender part of her psyche. Now that the shows were over, she concluded that although she had natural sexual power, she would rather put it in the past and continue with her original passion, the visual arts. We had not talked at all during her Hajj into Tantric Shangri-La, but we never forgot each other. I had a transgender lesbian crush on her since ninth grade, and we had been friends for most of that time. When she suddenly messaged me across the ether one afternoon, it came as no surprise. We talked for hours about her artistic values, and I set up the arrangement we have now. You would think just anyone with a wetwire would be able to make art in unlimited quantities and sell it, but it is much more rare than that. It takes a lot of will power and shamelessness for a person to share that part of their mind that up until the last century nobody ever saw. I suppose one could consider this art-form to be just as exhibitionist as exotic dancing, but I think those people would never stop labeling things exhibitionist. If exhibitionism is the making public of our private selves then it depends on what one considers private and public. Its all a question of whether your flesh is kosher I suppose.

Rain is a very rare occurrence in the state of South Texas, so when it does rain moods are apt to change dramatically and all the vampires come out more or less. Ameko dangled her feet off the bridge as she held onto the rail and painted to me. This was no ordinary rain; there was thunder, lightening, and everything that makes great mood paintings. There is a damn good reason "It was a dark and stormy night" always makes a good beginning. High contrast images of teardrops morphing into mechanical harlequins enter my brain and print into my backup. Often images are distorted with smears that contain compressed versions of Ameko's entire life. Montages are the best. Nothing is better than an image no individual produced. Images from films, from other artwork all mixed into Ameko's original imaginations. Repeat a process of image creation, pause, restart process, pause, do it in reverse, do it negative. This creates some rather humorous images like meatballs in milkshake swimming pools owned by the greedy Ghandi Führer. Those sell well in Toronto.

In the middle of one of these montages Ameko turns around and stands up on the bridge. She hears wet footsteps coming up the slope of the Harbor Bridge. She sees a shady figure creeping toward her through the red curtain of the ozone night. His overcoat is gray and old like a middle-aged librarian's and his hat is a gray fedora. "Excuse me! May I bother you for a bit?" The sketchy figure hollers through the moist air.

Ameko tenses, and we can hear our fear. "What do you want? Why should I trust some fucking stranger on the Harbor Bridge? This aint a singles bar you know. You are walking on holy ground pal. Nothing is sacred in this world except privacy on the cursed Harbor Bridge, and maybe blind albinos. Death is the only thing you can put faith in. I'm gonna jump and I don't want you to stop me so leave me alone!" Inside our matrix, we giggle in hope it will calm our nerves. Suicide games were one of our favorite pastimes in high school. Ameko would hold razors to herself while I begged her to stop. Nobody dies of razors these days anyway.

The man walked closer to Ameko. She walked further away toward a gap in the rail. The gap was smooth and straight cut like it was designed to be a doorway to the netherworld. "I'll jump fucker! Get away from me!"

"Don't jump miss. I just thought I recognized you. Please don't be afraid of me. If I have any perversions, they are all harmless. I hope you aren't going to jump, ma'am. You're too beautiful to do that. I know who you are, ma'am. You're Rain Girl? I think that was your stage name." He stopped approaching her in hope that she wouldn't jump.

"No I aint! And I never was! Although I can assure you that whoever this Rain Girl is, you never saw her. You only saw the flesh. You only saw the flesh moving around. If you had ever touched that flesh, you would have found it as satisfying as touching android flesh, cold and unyielding. Unless you're perversions are more than just mental?" They were close enough that they did not have to yell too much. At this range, he really did not look that creepy except for the fact that he was on the Harbor Bridge at three in the morning in the rain. It is one thing when young artist types are in the rain at night by themselves. It is another thing for old men that visit strip clubs.

"I just want you to know how beautiful I think you are. How you move in the rain." He was silent after this. The silence was overwhelming. The rain seemed to grow silent as well. Everything was focused on this strange man. "I don't think you should be ashamed of anything you did, ma'am. I think we are the ones who should be ashamed, but at the same time. What do you expect? I . . . I . . . I was in the navy for 20 years. I never got married or anything like that. I'm very grateful for what you did. It might seem crude, but its natural."

"Nature is what you make of it man. Just cause every other piss drunk asshole does it doesn't make it natural. I'm not ashamed of anything either. I just don't care about it anymore. And I'd rather not think about it now. And I'd rather like to be alone! You know, you can't expect the rest of the world to try to satisfy your desires. You have to do it yourself. You have to find your own desire and then go after it. I've just found mine, and I'm not giving up because it seems unlikely. Everything is unlikely if you give up. God, just get away and get a life!" Ameko became very angry at this point and just wished he would disappear so she wouldn't have to be so mean.

"Well, I have to admit. I followed you since you left the tattoo parlor. I never wanted to upset you. I just wanted to know if you would dance for me again, since its raining and all. I have tons of money. I'd pay you . . . please?" He held his hat in his hands and the water rolled off his bald head.

"Fuck man! Don't you get it. Leave me the fuck alone. I can't dance for you. My desire won't let me. I desire something beyond the flesh. Something beautiful that lies within us all, but that is rarely uncovered. My flesh has atrophied from exploitation and possession. I was 19 before I felt my flesh and knew it was my own, and by that time, it was tired and sick. I have to heal my own flesh, and that means getting rid of what people like you put into me. This disease called society poisons my body telling me what I am when it contradicts all I believe. You, with your excuses for possession, are not getting near me. Get away now!"

She backs away carefully, but she is shocked when he runs towards her and dives onto her. She falls to the wet black asphalt. He is on top of her angry and breathing heavily. "You're not getting away from me. You are beautiful and you must share that beauty. Its what's best for the rest of us. If you won't dance for me then I'll move you how I want you to move. I'll touch you when I want to touch you. I won't pay you anything. You will just do what I say." He begins to take off her jacket and clothes. She squirms violently trying to get out from under his mass. "Help!" she screams across the ether. I was panicking the whole time. I was looking to see if the rapist was wetwired anywhere. In most metropolitan areas about eighty percent of the populous are, but you never know in Corpus. Of course, anyone with a taste for pornography would instantly have been wetwired as soon as possible. I searched as fast as I could through all the profile databases for the area. He hit her hard across the jaw. Nothing broken but spirit. Finally, I found the profile and wetwire port. "Ameko! Here is his port address. Upload as many montages as you can. Anything! Fill his head with your real beauty. Do whatever you can." The man continued to tear at Ameko's clothing until he ripped through her skirt. He never expected what he saw there. It really depends on how you interpret it, but underneath her skirt and panties was not any recognizable genitalia. It wasn't what he saw months ago at the strip bar. It wasn't disgusting at all, but no matter what he did he couldn't look at it. His mind just filled with images of velvet, leather, cold metal, and shit. He couldn't stop thinking about shit.

Ameko screams into the blood red night air as she pushes as many images into his vision centers as she can. Unlike a cathode ray tube, you cannot just ignore the images. You cannot close your eyes unless you are skilled enough in the human hardware. The rapist fortunately was a novice dealer in child porn memories and did not know what to do. He could not see anything. The real world was somewhere behind these images, but he did not know where. He stands up and tries to stare at something, at the moon, or a spotlight. Finding nothing, he stumbles to the edge of the bridge where the gap in the rail invites him into the watery depths. Giving into fate and bad karma, he falls into the salt water. With the rest of the gloomy world gone and nothing but Ameko's art going through his brain all he could do was smile. Down through the bay he sunk smiling. Up to the surface, he floated back smiling. He drifted out to the Gulf of Mexico smiling.

Ameko had a tumor taken out after she raised enough money from the art sales. This did not give

any real reason for her to alter anything, but it gave her purpose. With this disease gone, her flesh was hers. She could do what she wanted with it. She cried in relief into the night as she draped her tattooed, pierced, enhanced body in what remnants of her clothes remained. She walked across the bridge to the north. The bridge always went north, but nobody ever went across. She walked to the nearest city, Portland, and bought a bus ticket to infinity.

---

# who are you RIGHT NOW

**Rick Gentry**

**Whenever a thought takes birth, an entity or point is created, and in reference to that point you are experiencing things. So, when the thought is not there, is it possible for you to experience anything or relate to anything?**

**Every time a thought is born, you are born. Thought in it's nature is a sharp blade, and once it's gone, that's the end of it. That is probably what the Hindu tradition meant by rebirth- death and birth and death and birth every moment. It is not that this particular entity- which is non-existing even while you are living- takes a series of births. This process occurs every moment.**

**The world you experience around you is also from that point of view. This point creates a space. If this point is not there, there is no space. So, anything you experience from this point is an illusion.**

**Not that the world is an illusion. All the Vedanta philosophers in India, particularly the students of Shankara, indulge in such frivolous, absolute nonsense. The world is not an illusion, but anything you experience in relation to this point, which itself is illusory, is bound to be an illusion, that's all. The sanskrit word Maya does not mean illusion in the same sense the english word. Maya means to measure. You cannot measure anything unless you have a point. So, if the center is absent, there is no circumference. This is basic arithmetic.**

***This point has no continuity.* It comes into being in response to the demands of a given situation. The subject does not exist there. It is the object that creates the subject. This runs counter to the whole philosophical thinking of India. The subject comes and goes and comes and goes in response to the things that are happening there. It is the object that creates the subject and not the subject that creates the object. If there is no object there, there is no subject here.**

**There is light. If the light is not there, you have no way of looking at anything. Light falls on an object and the reflection activates the optic nerves, which in turn activate the memory cells. When the memory cells are activated, all the knowledge you have about the object comes into cooperation. It is this process that creates the subject.**

---

# Mythology for the Third Millennium...

By Donald MAYERS

**Myth: noun.** From the Greek mythos

**1:** a usually traditional story of ostensibly historical events that serves to unfold part of the world view of a people or explain a practice, belief, or natural phenomenon

**2:** a popular belief or tradition whose origin has been lost that has grown up around something or someone

**3:** a person or thing having only an imaginary or unverifiable existence

**4:** the whole body of myths

When we look back on history, mythology has an importance and impact roughly the same as actual fact. Mythology is the source of our childhood fears, of things that go bump in the night, of things better left unnamed. Mythology is the sole source of religion. Mythology has served to answer life's greatest questions, if somewhat inaccurately. Roman and Greek mythology provided Sol and Helios, the sun gods. Scottish mythology gives us the Loch Ness Monster. American myths tell of Sasquatch or Big Foot and are paralleled by the Himalayan Rakshasa or Yeti. All of our Gods, demons, superstitions, heroes and heroines are alive in myth. But, I fear we have ushered them to death's door, and are asking for them, the long sleep.

As man's intelligence and wisdom increase we place more and more of our faith in the new religion...science. Man has mapped the genome. We know that people born with tails were not the result of an unholy union with a demon. We know the sun is not a blazing chariot pulled across the sky. We know the Earth does not rest upon the back of a giant turtle. I have enough concerns without worrying about a giant turtle deciding to take a walk closer to the sun.

So, where does that leave us now? All our true heroes are gone. Poor, strong Hercules shall never complete another task. I dread the time when we read children the tale of the great Orator who, with his mighty microphone, spoke for civil liberties and tax reform across the land! How about the tale of the brave President who was so quick witted he convinced a nation not to impeach him. Perhaps we shall read them the verses written about the dark and mysterious computer mogul and his evil plan to enslave the whole world with...compatible software!!! Yes, the children will hardly be able to sleep with such stirring tales of heroism and strength. I know my heart stirs when I hear such tales, or maybe it is only my stomach.

Are all our myths dead? Is there nothing left to make children hide under the blanket? *"You tell the truth Tommy. Genocidal leaders of small Balkan nations are always looking for people who lie."* Well, sometimes the truth is more frightening than fiction. This is where we are right now. We don't need to create stories to entertain and frighten. We have reality. In the last fifty years we have created enough weapons of mass destruction to level Asgard one thousand times over. In fact, Nuclear Winter corresponds very closely to the Norse Ragnarok, the Doom of the Gods, or Gotterdamerung. It is the standard "end of the cosmos" including earthquakes, the "winter of winters", darkness, turmoil, boiling seas, etc, etc, etc. Pardon me, but that is just too much before



bedtime.

We do have a sort of mythology, which corresponds well with this day and age. We have the Urban Legend. This is a legend that appears mysteriously and spreads spontaneously in varying forms, it contains elements of humor or horror, it makes good storytelling, and it does NOT have to be false. Although most are, many often have a basis in fact. Some of the more interesting titles for Urban Legends are as follows;

Organ Theft	Gangs Kill Sign Language Users	
Hitler's Left Testicle	Islam Virgins And Executions	Vampire Killing
AIDS needle in theatre seat	Bear Eats Baby	Bugs In Ear
AIDS needle in phone booth	Animals Eating Corpses	Candiru in Urethra
Dying From Asteroid Strike	Power Window Death	Drunken Birds
Peeing On Third Rail	School Bus Beheading	Exploding Bears
Vending Machine Deaths	Lefties Die Younger	Toad Licking

Laughable or not, they have an origin in our own time and cities. Whether or not they are the result of a good sense of humor or a bad sense of paranoia, they are here for now.

The only myth we have that actually defies (if not embraces) modern science and logic is that of aliens. The concept only grows larger as we progress. We know there are no vast Martian cities on the red planet but there may be microbes, which live or lived on Mars. Our current understanding of the universe and just how vast it is certainly supports the concept of life on another planet, in another galaxy. Most prominent scientists believe it likely that life exists in space. Most prominent scientists also believe in God or some equivalent force or being.

Perhaps this is the only Mythology for the third millennium. We have the explanations for most of the other questions our ancestors sought. Science, education, and technology have given us the means to replace fiction with fact. What else is there? As a certain writer noted, space is the final

frontier. Yes, we have been to the moon but this amounts to no more than sticking our toe in the water of a vast, deep ocean. Who knows what is really out there?

Aboriginal mythology tells of Mother Eingana, the world-creator, the birth mother, and maker of all water, land, animals, and kangaroos. Perhaps in the years to come our descendants will tell stories of beings from other planets who came to the Earth and created life. They will show their children pictures of ancient drawings, which bear a remarkable similarity to a humanoid in a space suit. Then again, there are more frightening options. They could tell of an ancient time before the Great War, when machines flew in the air and the oceans were clean. When people walked outside without the aid of air purifiers. When the sky was blue and most babies lived at birth.

The mythology for the third millennium can be either or none. It can be one of our choosing and our design. For there will always be questions that go unanswered and it is man's nature to find, at least, a temporary answer. Who made man? Who made the Earth? Maybe the aliens made man. Maybe God. And if God made man then you can thank him for giving you one last endless question to seek an answer for. Who made God?

---

## « The Time of the Naguals » Interzone anthology

---

*In French:*

“Le Temps des Naguals: Autour de Burroughs et Gysin” - 136 pages

Printed version : [Interzone Editions](#)

*In English:*

Tome 1: “The Time of the Naguals: Around Burroughs and Gysin” - 106 pages

Tome 2: [Research](#) - 163 pages

Tome 3: [Cut-ups](#) - 92 pages

Tome 4: [Poems](#) - 150 pages

Tome 5: [Short stories](#) – 117 pages

Tome 6: [Théâtre](#) - 64 pages

Tome 7: [Interzone](#) – 127 pages

*Other books published by Interzone Editions:*

"Alfred KORZYBSKI : SEMINAIRE DE SEMANTIQUE GENERALE 1937 -  
Transcription des Notes des Conférences de Sémantique Générale Données à Olivet  
College" : French translation: Isabelle AUBERT-BAUDRON [Interzone Editions](#)

Le Taxidermiste : Jose ALTIMIRAS & Francois DARNAUDET (bande dessinée)

The Taxidermist : Jose ALTIMIRAS & Francois DARNAUDET – English  
translation: Isabelle AUBERT-BAUDRON & Ken GAGE (comic book)

Printed version: [Interzone Editions](#)

Stella Matutina : Marylis (French)

Stella Matutina: Marylis, English translation: Isabelle AUBERT-BAUDRON & Paul  
O'DONOVAN

Printed version: [Interzone Editions](#)

---

© Isabelle AUBERT-BAUDRON  
[Interzone Editions](#)  
<http://www.interzoneeditions.net>

Juin 2011

[interzone.editions@interpc.fr](mailto:interzone.editions@interpc.fr)