

**UNIT MAINTENANCE MANUAL INCLUDING REPAIR
PARTS AND SPECIAL TOOLS LIST FOR MASK,
CHEMICAL-BIOLOGICAL: AIRCRAFT**

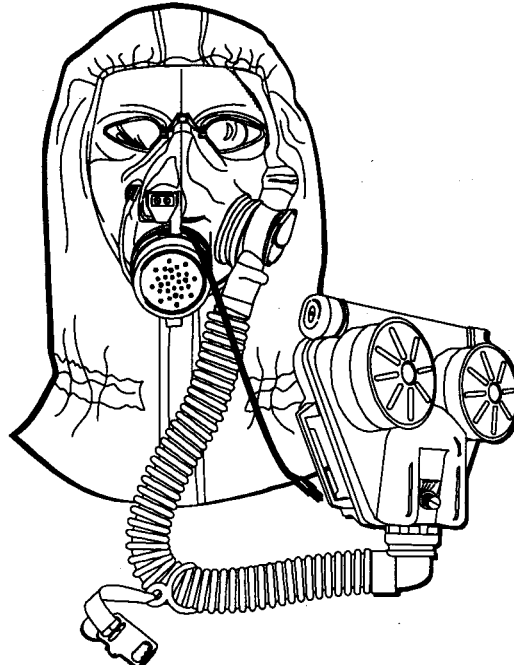

APACHE AVIATOR

M48

(4240-01-386-0198 SMALL)

(4240-01-386-4686 MEDIUM)

(4240-01-386-0201 LARGE)

(4240-01-386-0207 EXTRA LARGE)

WARNING

This document contains export-controlled technical data whose export is restricted by the Army Export Control Act (Title 22, U.S.C., Sec 2751 et seq) or Executive Order 12470. Violation of these export laws is subject to severe criminal penalties.

DISTRIBUTION STATEMENT C: Distribution authorized to U.S. Government Agencies and their contractors to protect technical or operational information. This determination was made on 28 April 1987. Other requests for this document will be referred to: Technical Director, U.S. Army Edgewood Research, Development and Engineering Center, ATTN: SCBRD-ENL-V, Aberdeen Proving Ground, MD 21010-5423.

DESTRUCTION NOTICE - Destroy by any method that will prevent disclosure of contents or reconstruction of the document.

WARNING

Wear a protective mask and clothing in accordance with local SOP when replacing canisters exposed to toxic agents.

If metal banding straps are used to secure packaging, exercise extreme care when removing them. The edges of metal binding straps are sharp, and they can injure eyes or cut skin.

Canisters shall be changed only in a nontoxic atmosphere.

When decontaminating a mask that has been exposed to toxic agents, wear a protective mask and clothing in accordance with SOP.

As a safety precaution, pilots needing prescription lenses shall go for a checkout ride in the helicopter when they receive their new masks or a prescription is changed. This is to assure that their vision is adequate to fly. Lithium-sulfur dioxide (LiSO₂) batteries which are used in this equipment contain pressurized sulfur dioxide (SO₂) gas. The gas is toxic, and the battery **MUST NOT be abused in any way which may cause the battery to rupture.**

A hissing sound from the battery or the smell of vinegar or rotten eggs indicates a leaking battery. If a leaking battery is detected, move battery to well-ventilated storage area and contact Defense Reutilization and Marketing Office (DRMO) for disposal.

LITHIUM-SULFUR DIOXIDE BATTERIES. Do not attempt to decontaminate batteries. Dispose of batteries according to TB 43-0130 and local SOP.

FIRST AID

For first aid information, refer to FM 21-11.

HEALTH/ENVIRONMENTAL HAZARD

There are two Mask Filter Canisters, the C2 and the C2A1. The C2 canister contains Chromium VI and damaged or unusable canisters are considered Hazardous Waste. (Chromium VI is a known carcinogen if inhaled or swallowed.) The C2A1 canister is chromium-free but must continue to be disposed of in accordance with State and Local Environmental Laws.

DO NOT throw away damaged or unusable canisters as ordinary trash.

DO turn in damaged or unusable canisters to your hazardous waste management office or Defense Reutilization and Marketing Office (DRMO).

**UNIT MAINTENANCE MANUAL
INCLUDING REPAIR PARTS AND SPECIAL TOOLS LIST
FOR
MASK, CHEMICAL-BIOLOGICAL: AIRCRAFT**

APACHE AVIATOR, M48

(4240-01-386-0198 SMALL)

(4240-01-386-4686 MEDIUM)

(4240-01-386-0201 LARGE)

(4240-01-386-0207 EXTRA LARGE)

REPORTING ERRORS AND RECOMMENDING IMPROVEMENTS

You can help improve this manual. If you find any mistakes or know of a way to improve the procedures, please let us know. Mail your letter, DA Form 2028 (Recommended Changes to Publications and Blank Forms), or DA Form 2028-2 located in the back of this manual directly to Technical Director, U.S. Army Edgewood Research and Development Engineering Center, SCBRD-ENL-V, Aberdeen Proving Ground, MD 21010-5423. A reply will be furnished to you.

WARNING- This document contains export-controlled technical data whose export is restricted by the Army Export Control Act (Title 22, U.S. C., Sec 2751 et seq) or Executive Order 12470. Violation of these export laws is subject to severe criminal penalties.

DISTRIBUTION STATEMENT C: Distribution authorized to U.S. Government agencies and their contractors to protect technical or operational information. This determination was made on 29 April 1987. Other requests for this document will be referred to: Technical Director, U.S. Army Edgewood Research and Development Center, SCBRD-ENL-V, Aberdeen Proving Ground, MD 21010-5423.

DESTRUCTION NOTICE Destroy by any method that will prevent disclosure of contents or reconstruction of the document.

TABLE OF CONTENTS

	Page
CHAPTER 1 INTRODUCTION	1-1
Section I General Information	1-1
Section II Equipment Description and Data	1-2
Section III Principles of Operation.....	1-3

TABLE OF CONTENTS (CONT)

		Page
CHAPTER 2	MAINTENANCE INSTRUCTIONS	2-1
Section I	Repair Parts, Special Tools (RPSTL), Test Measurement and Diagnostic Equipment (TMDE), and Support Equipment.....	2-1
Section II	Service Upon Receipt	2-1
Section III	Equipment/User Fitting Instructions.....	2-7
Section IV	Preventive Maintenance Checks and Services (PMCS)	2-17
Section V	Troubleshooting	2-35
Section VI	Maintenance Procedures.....	2-43
Section VII	Preparation for Storage or Shipment	2-62
Section VIII	Mask Servicing	2-64

TABLE OF CONTENTS (CONT)

	Page	Illus/ Figure
APPENDIX A REFERENCES	A-1	
APPENDIX B MAINTENANCE ALLOCATION CHART (MAC)	B-1	
Section I Introduction	B-1	
Section II Maintenance Allocation Chart for M48 Mask	B-4	
Section III Tool and Test Equipment Requirements.....	B-5	
APPENDIX C UNIT MAINTENANCE REPAIR PARTS AND SPECIAL		
TOOLS LIST	C-1	
Section I Introduction	C-1	
Section II Repair Parts List.....	C-1	
Group 00 Mask, Chemical-Biological Aircraft.....	C-1-1	C-1
Group 01 Mask Assembly	C-2-1	C-2
0101 Facepiece Assembly	C-3-1	C-3
010101 Inlet Valve Assembly	C-4-1	C-4
01010101 Actuator Shaft Assembly.....	C-4-1	C-4
010102 Outlet Valve Assembly	C-5-1	C-5
01010201 Valve Cover Assembly.....	C-6-1	C-6
010103 Communications Assembly.....	C-7-1	C-7
0102 Carrier, Mask.....	C-8-1	C-8
Group 02 Blower Assembly.....	C-9-1	C-9
Section IV Cross-Reference Indexes	C-1-1	
APPENDIX D EXPENDABLE AND DURABLE ITEMS LIST.....	D-1	
Section I Introduction	D-1	
Section II Expendable and Durable Items	D-2	
INDEX.....	Index-1	

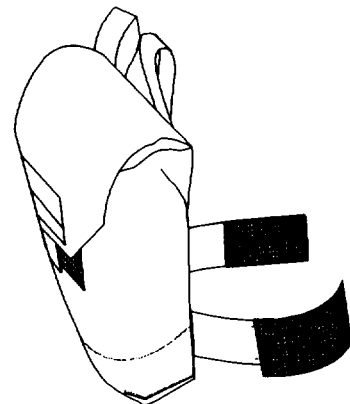
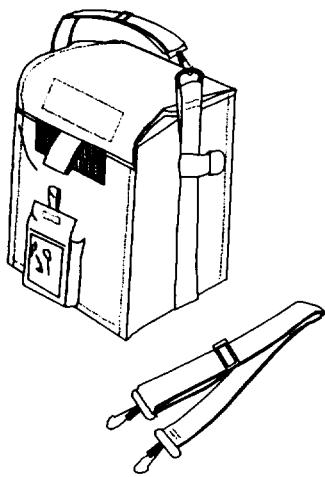
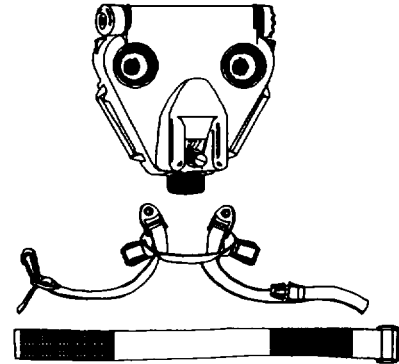
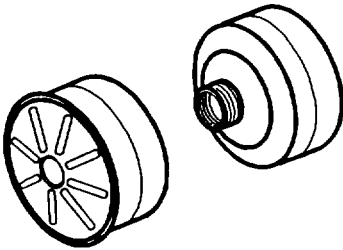
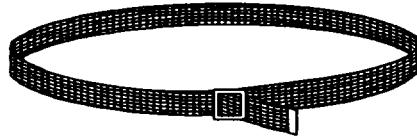
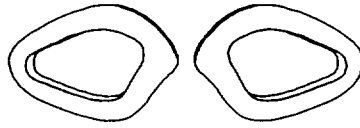
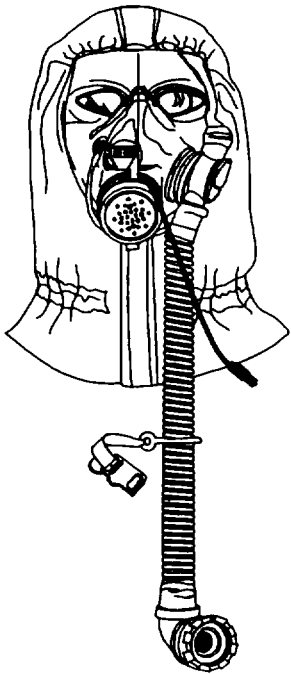

M48 MASK

CHAPTER 1 INTRODUCTION

Section I. GENERAL INFORMATION

1-1. SCOPE.

a. Type of Manual. This is a unit maintenance manual including repair parts and special tools list (RPSTL) for use with the M48.

b. Equipment Name and Model Number. Mask, Chemical-Biological, Aircraft: Apache Aviator, M48.

c. Purpose of Equipment. To protect face, eyes, and respiratory system from field concentrations of chemical-biological (CB) agents and riot control (RC) agents.

d. Special Limitations on Equipment. Does not protect against ammonia or carbon monoxide gases. While the mask will continue to filter out toxic particles, it will not supply oxygen; thus one cannot survive using this mask in an oxygen deficient environment.

1-2. MAINTENANCE FORMS AND RECORDS.

Department of the Army forms and procedures used for equipment maintenance will be those prescribed by DA PAM 738-750, The Army Maintenance Management Systems (TAMMS) as contained in Maintenance Management Update.

1-3. DESTRUCTION OF ARMY MATERIAL TO PREVENT ENEMY USE.

Refer to TM 43-0002-31 for methods of destruction.

1-4. PREPARATION FOR STORAGE OR SHIPMENT.

For instructions concerning storage or shipment, refer to para 2-18.

1-5. REPORTING EQUIPMENT IMPROVEMENT RECOMMENDATIONS (EIR).

If your mask needs improvement, let us know. Send us an EIR. You, the user, are the only one who can tell us what you don't like about your equipment. Let us know why you don't like the design or performance. Put it on an SF 368 (Quality Deficiency Report). Mail it to Director, U.S. Army Armament and Chemical Acquisition and Logistics Activity, ATTN: AMSTA-AR-QAW-A, Rock Island, IL 61299-6000. We will send you a reply.

1-6. SAFETY, CARE, AND HANDLING.

Caution must be used when handling contaminated masks and canisters. Decontamination procedures for the facepiece assembly and blower assembly can be found in para 2-22. For decontamination of other components of the M48 mask, follow procedures in FM 3-5.

Caution must also be used when using n-Amyl acetate to check facepiece for leaks. It is flammable, could irritate the skin under prolonged exposure, and may be toxic if inhaled in quantity. For first aid information, see FM 21-11.

1-7. CORROSION PREVENTION AND CONTROL (CPC).

a. Corrosion Prevention and Control (CPC) of Army material is a continuing concern. It is important that any corrosion problems with this item be reported so that the problem can be corrected and improvements can be made to prevent the problem in future items.

b. While corrosion is typically associated with rusting of metals, it can also include deterioration of other materials such as rubber and plastic. Unusual cracking, softening, swelling, or breaking of these materials may be a corrosion problem.

c. If a corrosion problem is identified, it can be reported using Standard Form 368. Use of key words such as corrosion, rust, deterioration, or cracking will assure that the information is identified as a CPC problem.

d. The Standard Form 368 should be submitted to:

Director
 U.S. Army Armament and Chemical Acquisition and Logistics Activity
 ATTN: AMSTA-AR-QAW-A/Customer Feedback Center
 Rock Island, Illinois 61299-6000

1-8. NOMENCLATURE CROSS-REFERENCE LIST.

This listing includes nomenclature cross-references used in this manual.

<u>Common Name</u>	<u>Official Nomenclature</u>
Canister Seal	Non-metallic Seal
Voicemitter Gasket	Packing, Preformed
Waist Strap	Carrier, Webbing Strap
Snap Hook	Hook Assembly
Canisters	CB Mask Canister
Battery Cap	Battery Filler Cap
O-Ring	Preformed Packing
Banana Oil	n-Amyl Acetate

1-9. LIST OF ABBREVIATIONS.

CB	Chemical and Biological
HDU	Helmet Display Unit
IHADSS	Integrated Helmet and Display Sighting System
IPD	Interpupillary Distance
RC	Riot Control
SARVIP	Survival Armor Recovery Vest Insert and Pocket
VDC	Voltage Direct Current

Section II. EQUIPMENT DESCRIPTION AND DATA

Paragraphs containing information on equipment characteristics, capabilities, and features; description of major components; and equipment data can be found in Chapter 1 of TM 3-4240-342-10, Operator's Manual for the M48 Mask.

Section III. PRINCIPLES OF OPERATION

The M48 mask protects the face, eyes, and respiratory system of the user from chemically, biologically, and radiologically toxic environments. Positive air pressure is supplied to the facepiece by the blower assembly.

The incoming air is pulled through two filter canisters, which remove contaminants from the air. The airflow is split three ways by controls on the facepiece assembly; the majority of the incoming air is directed into the facepiece assembly for breathing; another path feeds the lens defog system, which keeps the lenses free from condensation; the third path feeds the cooling duct, which directs air under the hood for user comfort.

Primary protection from toxic environments is provided by the facepiece assembly, which consists of the faceblank and the suspension harness. The faceblank contains the inlet valve assembly, outlet valve assembly, microphone assembly, voicemitter, drinking tube, lenses, and the butyl hood with a secondary skirt. The facepiece assembly is held securely on the head by the adjustable suspension harness.

1-3/(1-4 blank)

CHAPTER 2 MAINTENANCE INSTRUCTIONS

Section I. REPAIR PARTS, SPECIAL TOOLS (RPSTL), TEST MEASUREMENT AND DIAGNOSTIC EQUIPMENT (TMDE), AND SUPPORT EQUIPMENT

NOTE

All maintenance procedures in this manual may be performed by operator under Unit Maintenance supervision.

2-1. COMMON TOOLS AND EQUIPMENT.

For authorized common tools and equipment, refer to the Modified Table of Organization and Equipment (MTOE) applicable to your unit. Common tools contained in Electronic Equipment Tool Kit, TK 105G, are used for unit maintenance.

2-2. SPECIAL TOOLS, TMDE, AND SUPPORT EQUIPMENT.

Refer to Appendix C for Repair Parts and Special Tools List (RPSTL) and Appendix B Maintenance Allocation Chart (MAC) for TMDE and Support Equipment.

2-3. REPAIR PARTS.

Repair parts are listed and illustrated in Appendix C of this manual.

Section II. SERVICE UPON RECEIPT

2-4. GENERAL.

This section contains instructions, procedures, or services to be performed upon receipt of a new or overhauled mask. These services include unpacking and checking the mask.

2-5. SERVICE UPON RECEIPT OF MATERIEL.

This task covers:

Unpacking and checking Unpacked Equipment.

INITIAL SETUP**Materials/Parts**

Battery (Item 1, App B, TM 3-4240-342-10)

UNPACKING**WARNING**

If metal banding straps are used to secure packaging, exercise extreme care when removing them. The edges of metal binding straps are sharp and can injure eyes or cut skin.

NOTE

Retain box, lid, and internal packaging for extended storage or reshipment.

1. Plywood Container.
 - (a) Cut and remove banding straps (1) and remove screws (2).
 - (b) Pry lid (3) off box.

2. Large Inner Box.
 - (a) Remove large inner box (4) from plywood container.
 - (b) Cut tape (5) securing inner box lid (6).
 - (c) Remove inner box lid.
 - (d) Remove carrier (7) from inner box and plastic bag.
 - (e) Remove cardboard section divider (8) from inner box.
 - (f) Remove facepiece assembly carrier (9).

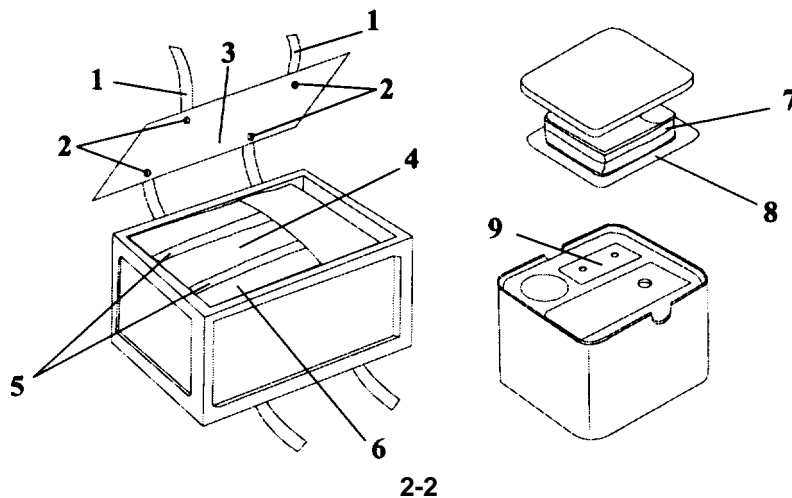

NOTE

IPD staples are not shipped with the mask. The proper IPD staple (Item 15, App D), if required, will be furnished and installed in the facepiece assembly by Unit Maintenance during initial mask fitting.

- (g) Remove mask holder insert (10).
- (h) Remove lens cushions (11).
- (i) Remove facepiece assembly abrasive cover (12).
- (j) Remove facepiece assembly (13). Remove and discard plastic cover from facepiece assembly.
- (k) Remove faceform (14) from facepiece assembly.
- (l) Remove plastic bag and plastic cap from microphone cable on facepiece assembly.

NOTE

Keep faceform for future facepiece assembly storage. Insert faceform in facepiece if mask will be stored for 30 days or longer.

- (m) Remove two cans (15) containing canisters.

NOTE

If mask is to be stored for 30 days or longer before being issued to user, do not open cans; proceed to step p.

- (n) If canisters are to be installed, remove them from cans and discard cans. Remove canister covers if present.
- (o) Record date can was opened in accordance with (IAW) unit SOP.

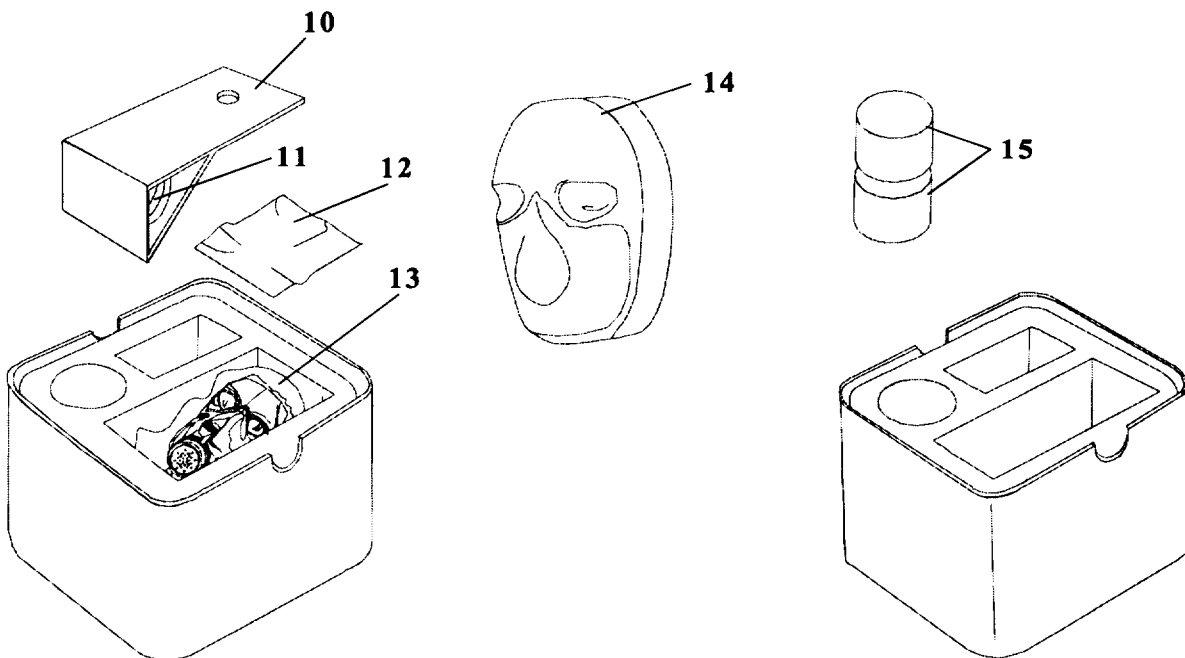

2-5. SERVICE UPON RECEIPT OF MATERIEL (CONT).

(p) Make sure a gasket (16) is present in the threaded port of the swivel to prevent air leakage.

3. Small Inner Box.

Lift small inner box (17) out of plywood container (18), lay it flat, and lift off lid.

NOTE

The web belt is contained in a separate plastic bag.

(a) Remove blower assembly (19) and arm band (20) from small inner box.

(b) Take web belt and buckle (21) out of plastic bag (22) and discard bag.

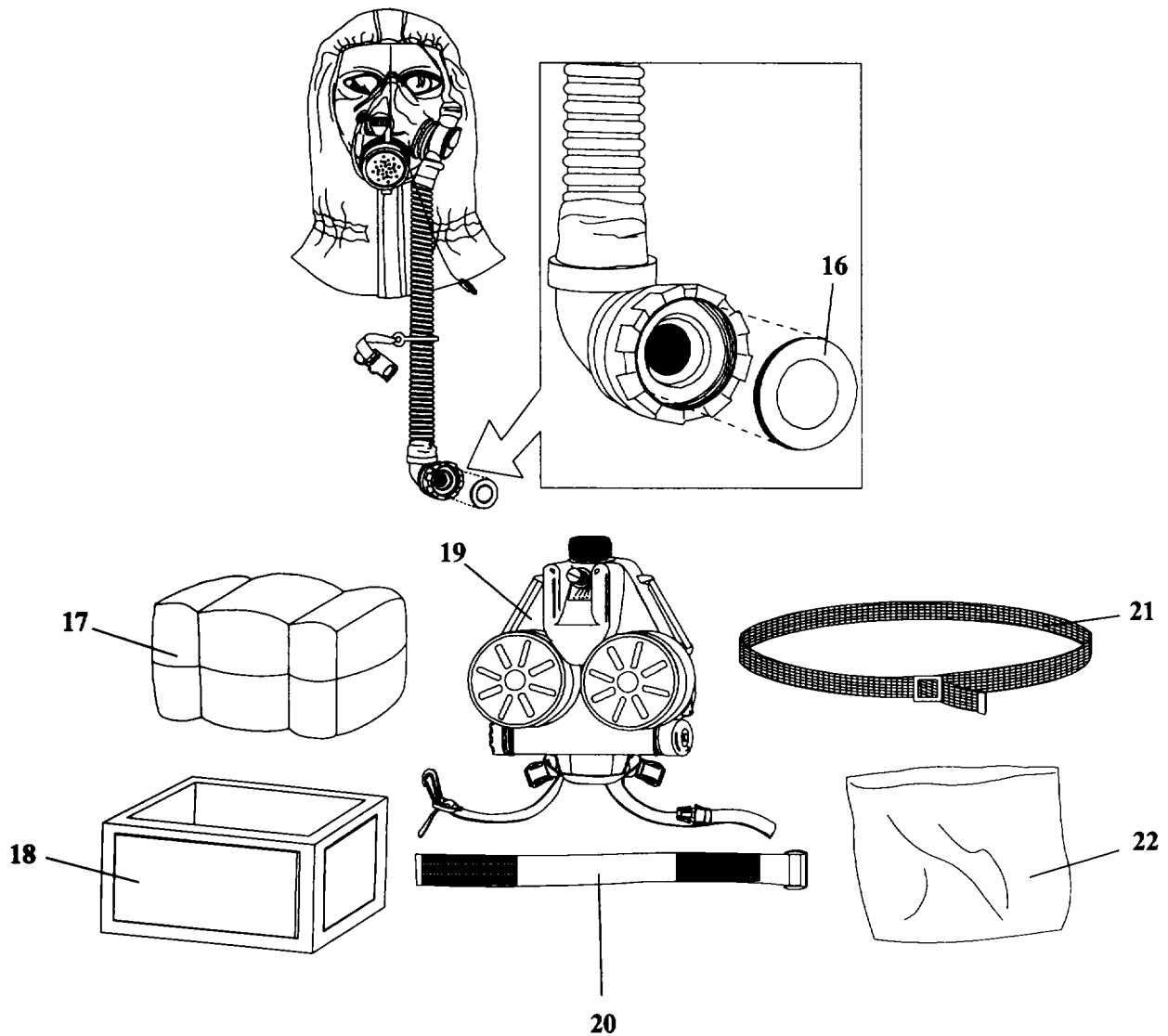

CHECKING UNPACKED EQUIPMENT.

1. Inspect the equipment for damage incurred during shipment. If the equipment has been damaged, report the damage on SF 364, Report of Discrepancy (ROD).
2. Check equipment against packing slip for completeness of shipment. Report all discrepancies in accordance with the instructions of DA PAM 738-750.
3. Inspect the equipment for modifications. Make note of modifications on appropriate equipment records.
4. Stow equipment in carrier as described in Operator's Manual, TM 3-4240-342-10.

2-6. INDIVIDUAL MASK IDENTIFICATION.

This task covers:

Mask Carrier Identification.

INITIAL SETUP**Materials/Parts**

Ink, Marking Stencil (Item 9, App D)

MASK CARRIER IDENTIFICATION**NOTE**

Do not make permanent identification markings on the facepiece assembly, blower assembly, or mask carrier (AR 700-84).

1. Obtain a removable tag to fit the carrier window pouch.
2. Mark the tag with the user's name or code number. Additional fitting information or blower identification may also be included.

NOTE

Each unit may derive its own code. Do not include any information that may identify the parent organization. Avoid using codes similar to those of neighboring units.

3. Place the completed identification tag in the carrier window pouch.

Section III. EQUIPMENT/USER FITTING INSTRUCTIONS

2-7. BLOWER PREPARATION AND INSTALLATION.

This task covers:

Blower Preparation and Installation.

INITIAL SETUP

Tools

Tool Kit, Electronic Equipment TK 105G (App B)

BLOWER PREPARATION AND INSTALLATION

1. Make sure gaskets (1) are installed in canister ports (2).
2. Screw in canisters clockwise until they make contact with the gaskets. Rotate an additional 1/4 to 1/2 inch to assure that leakage will not occur.
3. Unscrew battery cap (3) and install battery with electrical contacts facing inward. Reattach battery cap.
4. Turn switch through the different speeds to ensure air is flowing from outlet port (4). Turn blower off.
5. Ensure gasket (5) is installed properly on swivel assembly (6). Screw the swivel assembly onto the outlet port until handtight.
6. Turn blower on and ensure air is flowing into facepiece.
7. Turn blower off.

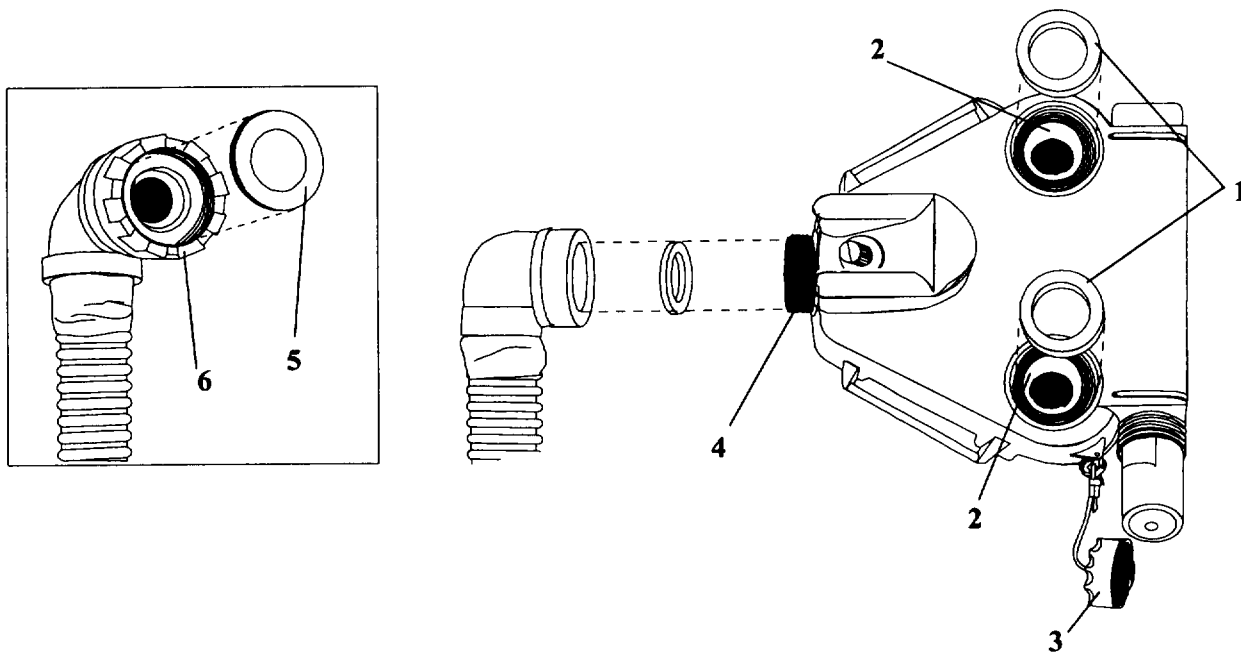

2-8. FACEPIECE ASSEMBLY ADJUSTMENT.**INITIAL SETUP****Tools**

Tool Kit, Electronic Equipment TK 105G
(App B)

Materials/Parts

IPD Staple Kit (Item 15, App D)
Isopropyl Rubbing Alcohol (Item 10, App D)
Cheesecloth (Item 7, App D)

Personnel Required

Unit level ALSE technician
Soldier (operator)

Equipment Condition

Hood over front of facepiece assembly.
Suspension harness to rear of facepiece assembly.
Soldier seated with glasses and headgear removed.
Faceform removed from facepiece assembly.
Blower attached and set on lowest speed.

FACEPIECE ASSEMBLY ADJUSTMENT**NOTE**

Make sure the soldier is clean-shaven. An unshaven face could degrade the protection afforded by the facepiece assembly. No hair styles which could affect the fitting of the mask should be worn.

The primary objective in fitting the soldier is visual acuity while maintaining comfort.

1. Loosen all straps (1).
2. Have soldier hold suspension system (2) using both hands.

NOTE

When donning facepiece assembly, make sure donning tab is not folded under suspension harness

3. Have soldier place chin in chin cup (3), and pull suspension crown (2) over head while brushing hair back.
4. Make sure donning tab (4) is centered on back of head and straps are not hanging over or cutting into ears.

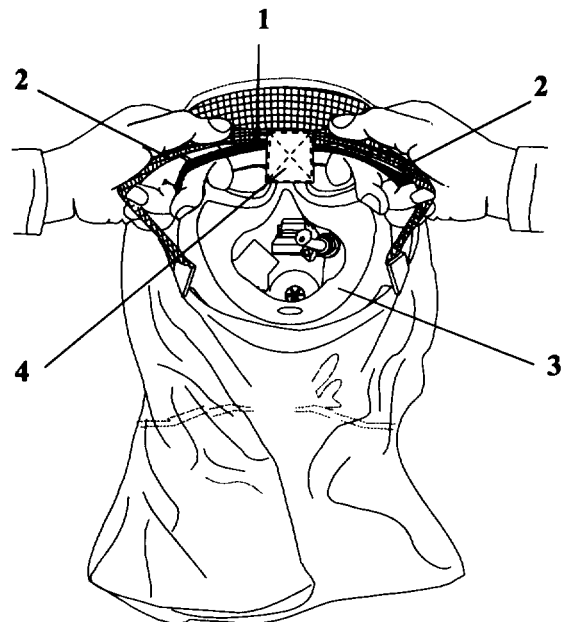

5. As the facepiece assembly is being donned make sure:
 - (a) Suspension crown (2) is centered on top of head.
 - (b) Straps are not over ears.
 - (c) Ears are between temple and cheek straps.
 - (d) Straps are not cutting into ears.
 - (e) Donning tab (4) is not folded up under suspension crown.
6. Have soldier position facepiece assembly for optimum comfort.

NOTE

Use short jerks instead of long pulls to tighten straps. Do not tighten temple straps at this time.

7. Tighten chin straps (5) by pulling on tabs.
8. Check the following areas to make sure facepiece assembly fits properly:
 - (a) Check that side edge (6) of facepiece assembly is no closer than 1/2 inch to ears.
 - (b) Check that temple (7) and chin straps do not cut into soldier's ears.
 - (c) Check that straps are flat against head, not twisted, and are in a straight line with tabs (8).

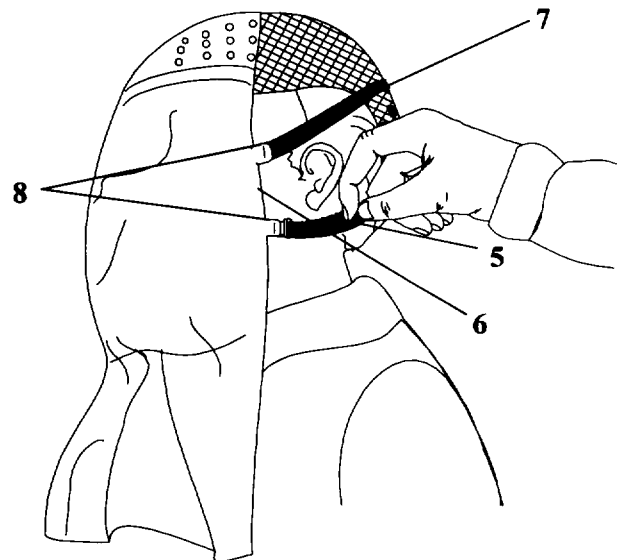
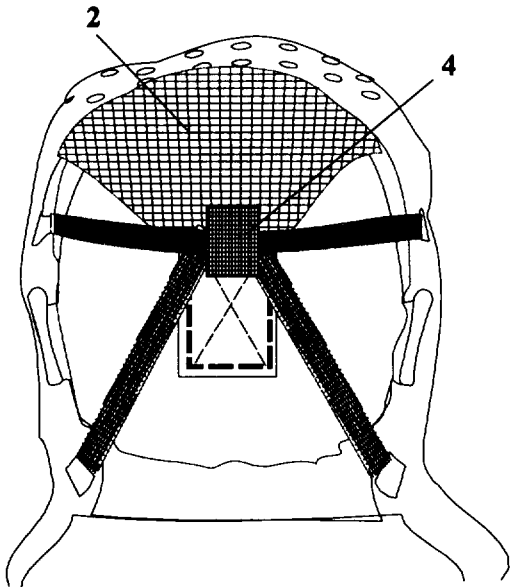

2-8. FACEPIECE ASSEMBLY ADJUSTMENT (CONT).

- (d) Check that facepiece assembly does not dig into the chin area of the wearer.
- (e) Gently pull hood back over soldier's head and into normal wearing position.
- (f) Check that facepiece assembly does not contact bridge of nose to cause discomfort.
- (g) Check that forehead area of the facepiece assembly is not so tight that it causes discomfort or so loose that it causes buckling in the temple area.

NOTE

Make sure facepiece assembly does not press so tightly that soldier's eyes are partly closed.

9. Check that soldier's pupils are centered in the eyelens (9).

NOTE

If facepiece assembly fails to meet above fitting criteria, readjust straps or try another size facepiece assembly.

10. Pinch bridge of nose or spread lenses apart until soldier indicates a comfortable fit and optimum vision. Optimum vision check includes peripheral vision, interference around bridge of nose, and vertical vision. If comfort or vision is improved when pinching or spreading the lenses an IPD staple may be required, as detailed in step 12.

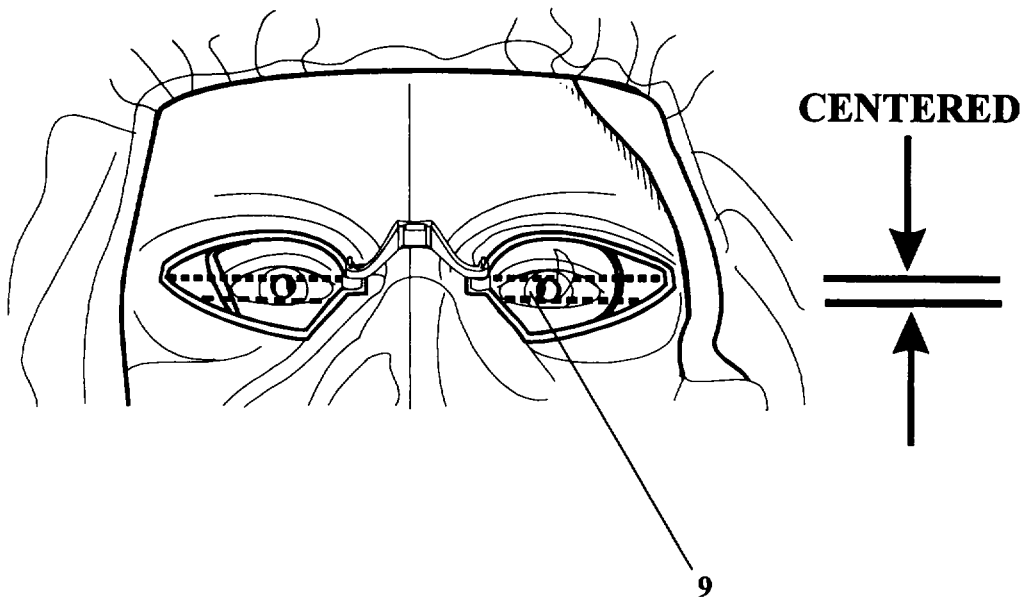

CAUTION

Use care when installing IPD staples. Staples can scratch eyelens material.

11. Select and install IPD staple, if required, as follows:

(a) Obtain test button (10) from plastic bag.

NOTE

Staple size is located on top of staple and behind keyway.

(b) Obtain staple number 61 (11), or appropriate size, if soldier knows his staple size, from plastic bag.

(c) Insert test button into keyway of staple from the top (numbered side of staple).

(d) Using test button, position staple over IPD mounting posts (12) located on facepiece assembly (13).

(e) On facepiece assembly, pinch bridge of nose or spread lenses apart, as required, to align holes in staple with IPD mounting posts.

(f) Using test button install staple on IPD mounting posts.

(g) Check staple fit for comfort and optimal vision. If staple fit is comfortable and vision is optimal, proceed to step 1; otherwise, perform steps h thru k.

(h) Using test button remove staple from IPD mounting posts.

(i) Remove test button from staple.

(j) If staple fit is too tight over bridge of nose, obtain next larger size staple from plastic bag. If staple fit is too loose, obtain next smaller size staple from plastic bag.

(k) Repeat steps d thru g as required until staple fit is comfortable and vision is optimal.

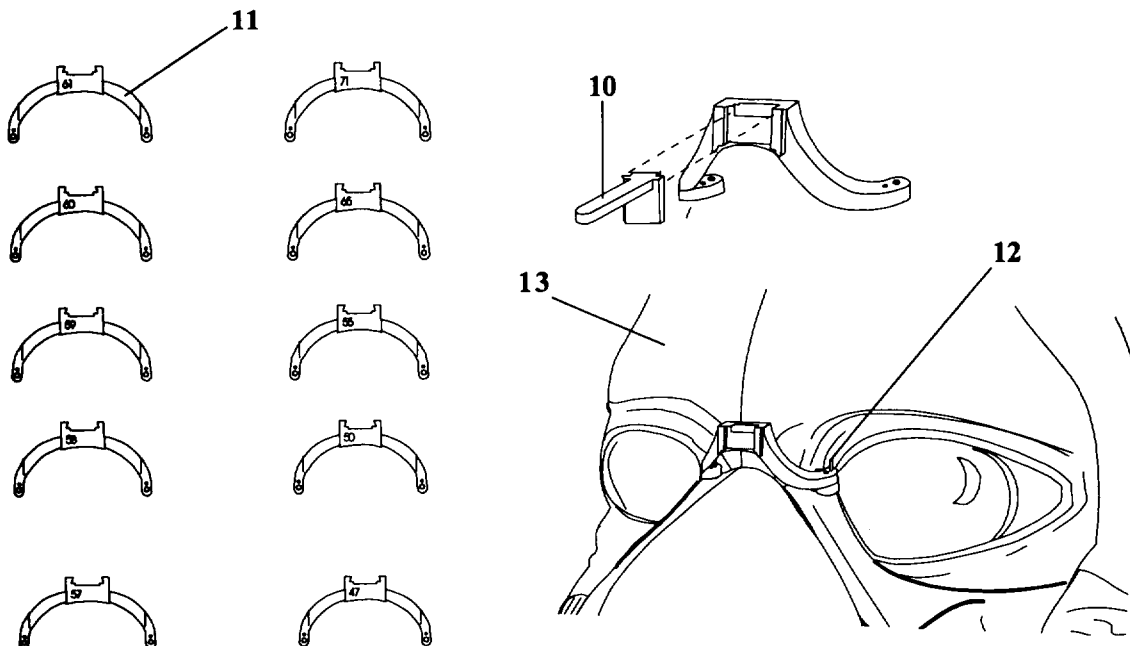

2-8. FACEPIECE ASSEMBLY ADJUSTMENT (CONT).

- (l) Remove test button from staple.
- (m) Remove facepiece assembly.

CAUTION

Care should be taken not to scratch lenses during the following procedures.

- (n) Install one retainer clip (14) on IPD mounting post as follows:
 - (1) Position slotted hole of retainer clip behind IPD mounting post with retainer clip slot facing out and away from lens.
 - (2) Grasp retainer clip and pull away from facepiece assembly, approximately 1/16-inch, until groove in IPD mounting post is seated in slot of retainer clip.
 - (3) Rotate retainer clip until slot faces towards bridge of nose.
 - (o) Repeat step (n) to install other retainer clip.
 - (p) Obtain filler button (15) from plastic bag.
 - (q) Position filler button over top of keyway (16) in staple and press button into keyway.
12. Repeat steps 1 thru 7 to ensure proper fit.

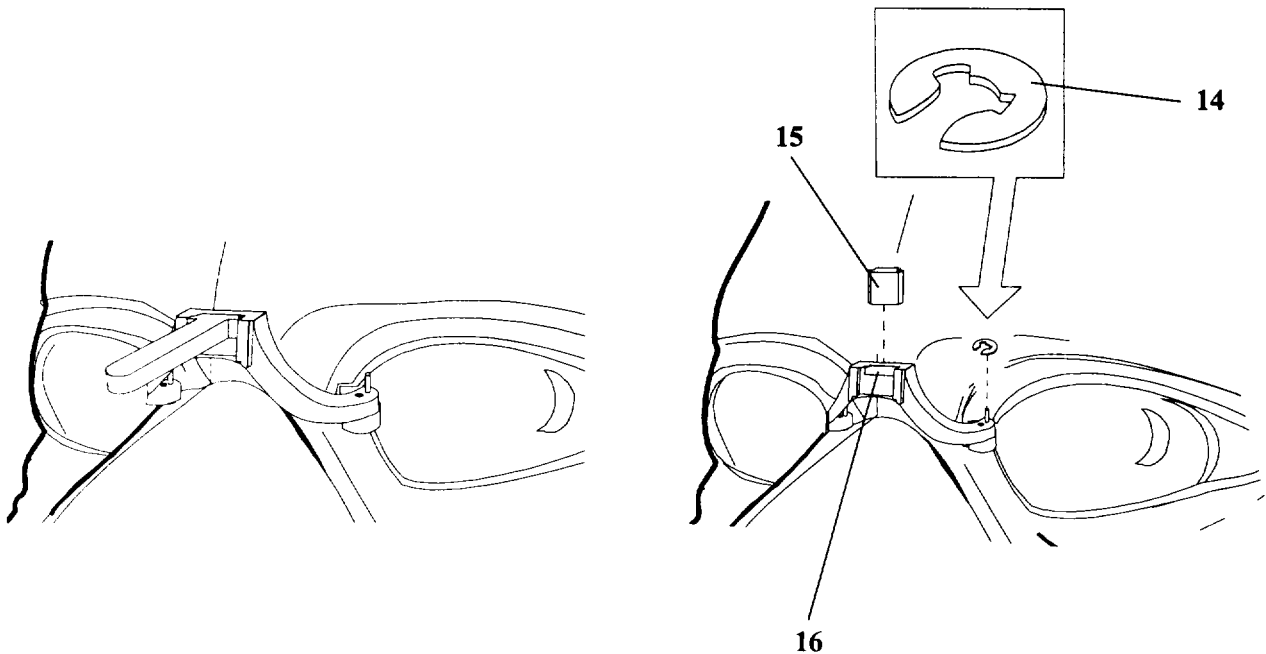

13. Adjust temple strap (7).

NOTE

If soldier feels discomfort around the eyes, eyelens cushions may be installed. If facepiece eyelens cushions are not needed, proceed to step 16.

14. If necessary for comfort remove facepiece and install eyelens cushions (17) as follows:

- (a) Wipe inside of facepiece around lenses using alcohol and a clean cheesecloth before installing eyelens cushions.
- (b) Peel protective paper off adhesive on eyelens cushions and press cushions in place inside of facepiece assembly.
- (c) Repeat steps 1 thru 7 to ensure proper fit.

15. Adjust temple strap.

16. Gently pull hood back over soldier's head.

17. Remove facepiece assembly.

18. Record proper IPD staple size for future reference according to unit SOP.

19. Issue remainder of mask assembly to soldier.

WARNING

Verify the fit of the helmet while wearing the mask to prevent discomfort during flight.

As a safety precaution, pilots needing contact lenses shall go for a checkout ride in the helicopter when they receive their new mask or a prescription is changed. This is to assure that their vision is adequate to fly.

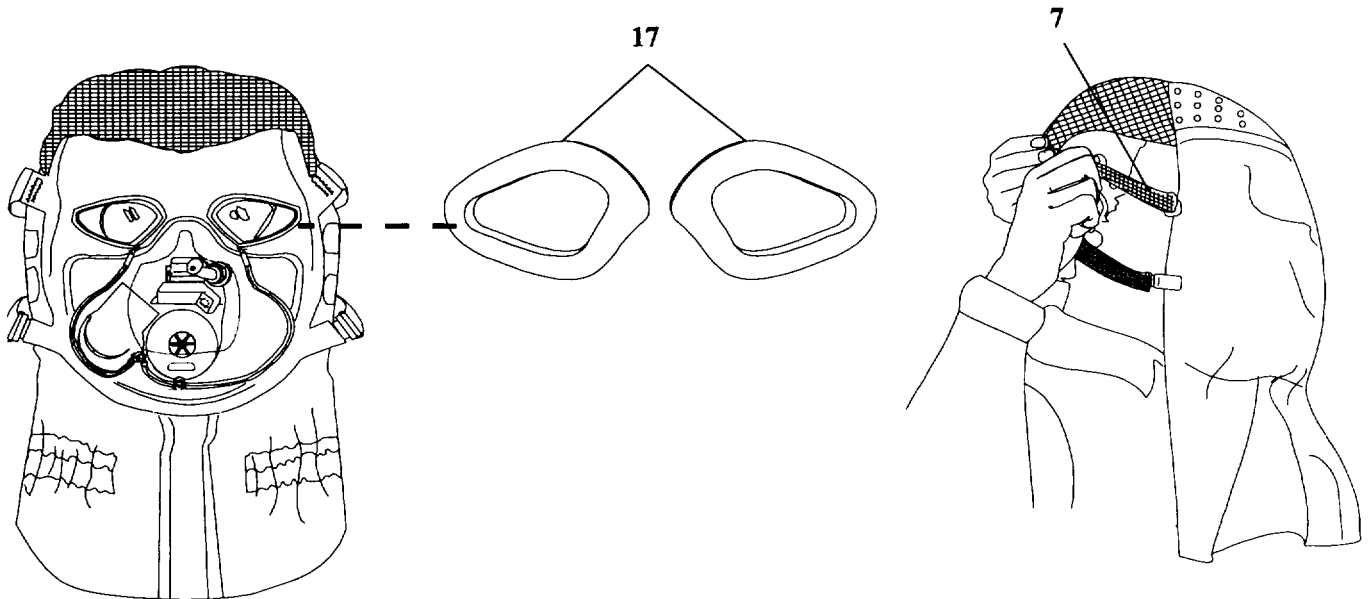

2-9. WEB BELT ADJUSTMENT.

This task covers:

Web Belt Adjustment

WEB BELT ADJUSTMENT

With protective garments on, put on web belt (1) and adjust by cutting.

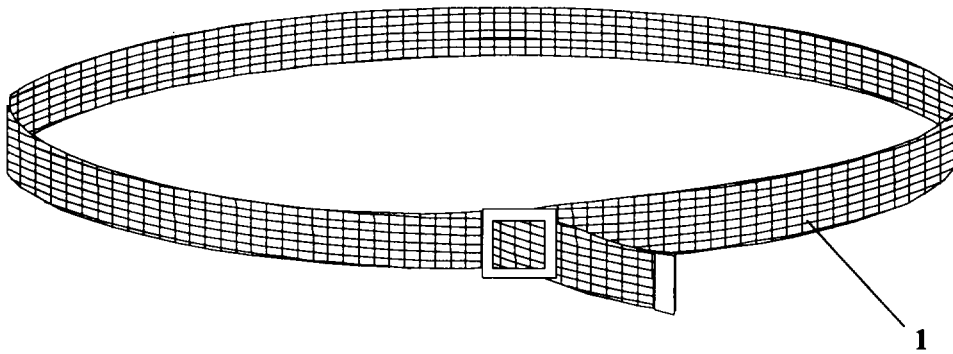

2-14

2-10. MASK ASSEMBLY FUNCTIONAL TEST.

This task covers:

Testing.

INITIAL SETUP**Materials/Parts**

n-Amyl Acetate (Banana Oil) (Item 13, App D)
Gloves, Chemical (Item 8, App D)

Personnel Required

ALSE technician
Soldier (operator)

Equipment Condition

The facepiece is adjusted to the soldier (para 2-7).
The lens defogging control and outlet valve flow control are set to allow maximum airflow (TM 3-4240-342-10, para 2-8c).
The hood cooling duct control is closed (TM 3-4240-342-10, para 2-8c).

WARNING

Do NOT touch your skin (or the operator's) with n-Amyl acetate (banana oil). It could irritate the skin. Wear gloves if an application could wet your fingers.

Do NOT smoke around banana oil. Keep banana oil away from open flame.

Do NOT test facepieces in an enclosed or poorly ventilated area. Test outdoors or in a well aired room. Banana oil may be toxic if inhaled in quantity.

CAUTION

Do not touch facepiece with banana oil. It is a solvent and could damage the facepiece.

1. Have soldier don facepiece and turn on blower before opening the bottle of banana oil.

NOTE

If operator smells banana oil just before masking, test results will be inaccurate.

2. Dip applicator in banana oil.

NOTE

Instruct soldier to breathe deeply through nose only.

3. Move applicator around the outside of the mask maintaining 1 or 2 inches of clearance between the applicator and the mask.

2-10. MASK ASSEMBLY FUNCTIONAL TEST (CONT).

4. While operator is looking straight ahead, move applicator around outlet valve (1), voicemitter (2), inlet valve (3), and lenses (4).
5. Move applicator along the length of the hose (5), around the swivel assembly (6), canisters (7), and the blower assembly (8).
6. If soldier can smell banana oil, replace canisters and retest.

NOTE

You should wait at least 30 minutes before retests.

7. If soldier smells banana oil, perform procedures in table 2-3 and retest.
8. If soldier can still smell banana oil, replace mask.
9. If soldier cannot smell banana oil, have him remove facepiece and smell the applicator to be sure his sense of smell is not impaired.

NOTE

If the soldier's sense of smell is impaired, the facepiece must be tested in a CS (irritant) chamber or using a smoke tube (Item 16, App D) and an aspirator bulb (Item 3, App D) which produces an irritating acid smoke. Read and follow directions on the kit. The smoke tube test should be conducted in still air in an area that can be ventilated.

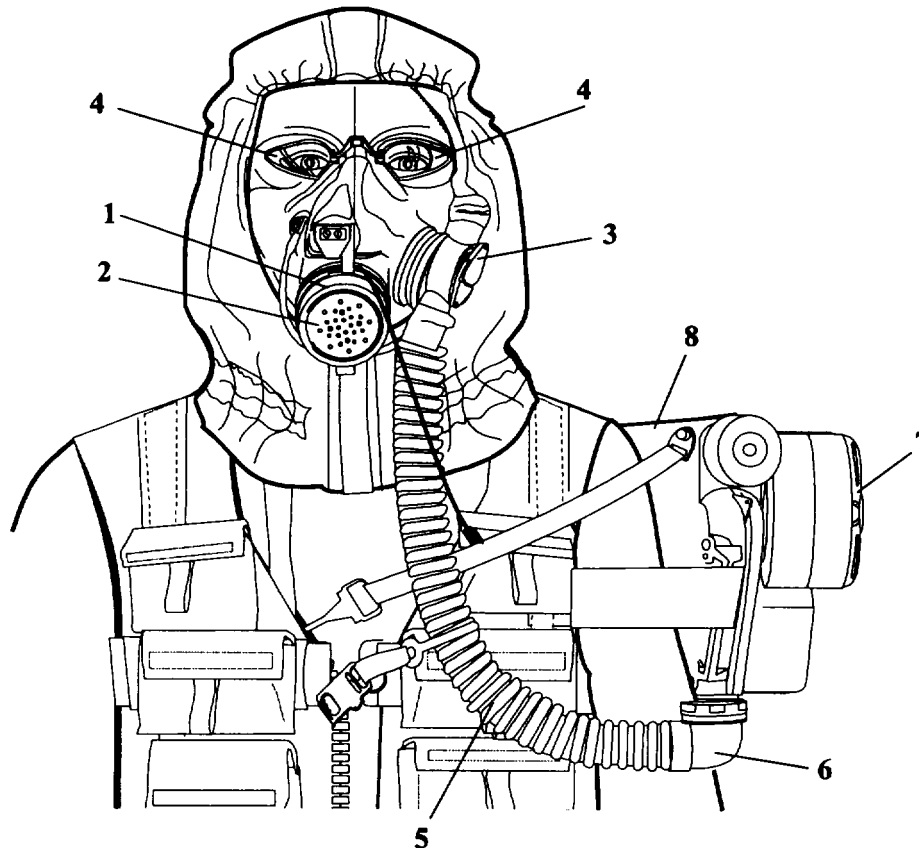

Section IV. PREVENTIVE MAINTENANCE CHECKS AND SERVICES (PMCS)**2-11. GENERAL.****NOTE****IN TIME OF COMBAT, THE SEMI-ANNUAL PMCS BECOMES WEEKLY.**

a. General. The PMCS Table has been provided so you can keep your equipment in good operating condition and ready for its primary mission. PMCS procedures in this section are to be performed by a unit maintenance technician or by the user, under unit maintenance supervision.

b. Warnings and Cautions. Always observe the warnings and cautions appearing in your PMCS table. Warnings and cautions appear before the applicable procedures. You must observe all warnings and cautions to prevent serious injury to yourself or others and to prevent damage to your equipment.

2-12. INTRODUCTION TO PMCS PROCEDURES.

a. Table Entries. The following paragraphs describe the information presented in each column of the PMCS table.

- (1) **Item Number Column.** Numbers in this column are for reference. When completing DA Form 2404 (Equipment Inspection and Maintenance Worksheet), include the item number for the check/service indicating a fault. Item numbers also appear in the order that you must do checks and services for the intervals listed.
- (2) **Interval Column.** This column tells you when you must do the procedure in the procedure column.
- (3) **Item to Check/Service Column.** This column identifies the item to be checked or serviced.
- (4) **Procedure Column.** This column gives the procedure you must do to check or service the item listed in the Item to Check/Service column to know if the equipment is ready or available for its intended mission or for operation. You must do the procedure at the time stated in the interval column.
- (5) **Not Fully Mission Capable If: Column.** Information in this column tells you what faults will keep your equipment from being capable of performing its primary mission. If you make check and service procedures that show faults listed in this column, do not operate the equipment. Follow standard operating procedures for maintaining the equipment or reporting equipment failure.

b. Other Table Entries. Be sure to observe all special information and notes that appear in your table.

Table 2-1. PREVENTIVE MAINTENANCE CHECKS AND SERVICES FOR M48 MASK (CONT)

Item No.	Interval	Item to Check/Service	Procedure	Not Fully Mission Capable If;
			<p style="text-align: center;">NOTE</p> <p style="text-align: center;">Blower must be separated from swivel assembly before performing PMCS. Refer to operating procedures, Operators Manual, TM 34240-342-10.</p> <div style="text-align: center;">  </div> <p>a. Visually inspect inside and outside surfaces for dirt, mud, and greasy or oily substances.</p> <p>b. Check faceblank (1) for splits, holes, tears, splits, nicks, or dry rot.</p> <p>c. Check rubber next to lenses (2), inlet valve assembly (3), outlet valve assembly (4), microphone outside backing plate (5), hood cooling duct (6), and drink tube pass-through assembly (7) to be sure these components will not pull away from faceblank.</p>	<p>Dirt or grease is on sealing surfaces. Dirt, mud, or greasy substances interfere with normal operation.</p> <p>Faceblank has holes, tears, nicks, or dry rot which will allow air to enter facepiece assembly.</p> <p>Lenses, inlet valve assembly, outlet valve assembly, microphone outside backing plate, hood cooling duct, or drink tube pass-through assembly pull away from faceblank.</p>

Table 2-1. PREVENTIVE MAINTENANCE CHECKS AND SERVICES FOR M48 MASK (CONT)

Item No.	Interval	Item to Check/Service	Procedure	Not Fully Mission Capable If;
			<p>d. Check hood assembly (8) and inner skirt (9) for chafed areas, cuts, tears, or separation of seams, and check hood for separation from faceblank (1). Check for areas above neck elastic where rubber coating is worn away. Check areas below neck elastic for worn areas larger than a dime.</p> <p>e. Check neck closure (10) for chafed or worn areas, cuts, stretched elastic.</p> <p>2 Check suspension harness. Make sure it stretches. Firmly, hold faceblank (1) with one hand. With the other hand, stretch each strap (2) 1-1/2 inches from facepiece assembly.</p> <p>b. Check straps (2) for cuts, tears, missing metal clips (3), or deterioration such as mildewing or fraying.</p> <p>c. Check for missing, bent, or broken clip-buckles (4).</p>	<p>Hood assembly and inner skirt has cuts, tears, or separation of seams, or has pulled away from faceblank. Hood assembly has areas above neck elastic where rubber coating is worn away, or areas below neck elastic larger than a dime that are worn away.</p> <p>Neck closure is chafed, torn, cut, separated at seams, or elastic is stretched enough to affect normal operation.</p> <p>Semi- SUSPENSION a. Annual HARNESS recovery, or suspension harness will not hold facepiece assembly firmly against face.</p> <p>Straps are cut, torn, frayed, have missing parts, or have deteriorated.</p> <p>Clip-buckle assemblies are missing, bent, or broken.</p>

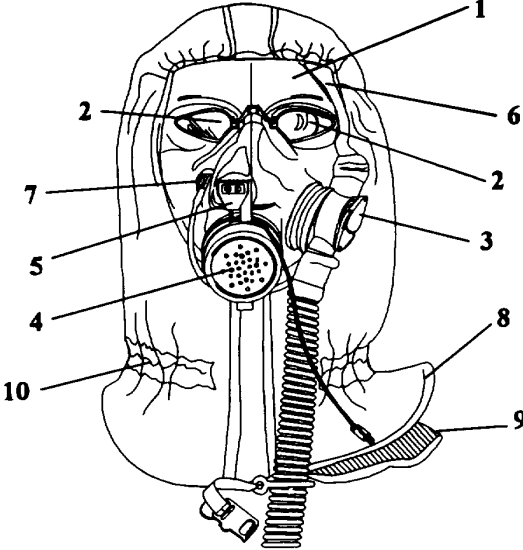
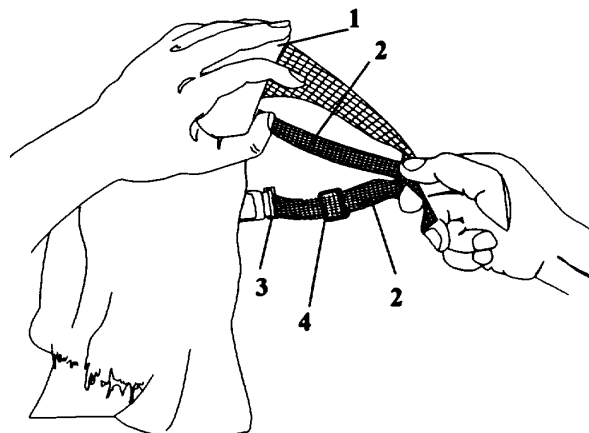

Table 2-1. PREVENTIVE MAINTENANCE CHECKS AND SERVICES FOR M48 MASK (CONT)

Item No.	Interval	Item to Check/Service	Procedure	Not Fully Mission Capable If;
			<p>3 Check inlet valve body (1) for cracks, dents, missing parts, or loose faceblank fit. Check that inlet valve cannot be rotated in faceblank.</p> <p>b. Check that actuator shaft assemblies (2) are free to move, and set screws (3) are present and adjusted properly.</p>  <p>c. Remove air deflector (4) inside faceblank (5) by squeezing edges of air deflector and pulling upward until deflector snaps out of groove.</p> <p>d. Check that inlet valve disk (6) and retaining ring (7) are present.</p> <p>e. Check that 900 ell branch (8) and defogging tubes (9) are not damaged, kinked, or detached from fitting or lens.</p>	<p>Semi- INLET VALVE a. Inlet valve body is cracked, Annual ASSEMBLY dented, or has parts missing. Inlet valve body can be rotated in faceblank.</p> <p>Actuator shaft assemblies bind or stick. Set screws are missing or excessively loose.</p> <p>Disk inlet valve or retaining ring is missing.</p> <p>Fitting is broken, cracked, or detached from inlet valve assembly. Defogging tubes are kinked, cracked or detached</p>

Table 2-1. PREVENTIVE MAINTENANCE CHECKS AND SERVICES FOR M48 MASK (CONT)

Item No.	Interval	Item to Check/Service	Procedure	Not Fully Mission Capable If;
			<p>f. Check air deflector (4) for cracks, deformation, or pieces broken off.</p> <p>g. Align notch on air deflector with 900 ell branch (8) and snap air deflector into groove around inlet valve assembly on inside of facepiece assembly by squeezing edges of air deflector.</p>	<p>Air deflector is cracked, deformed, or has pieces broken.</p>

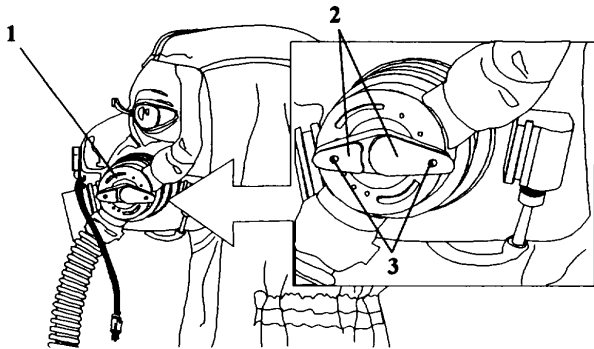
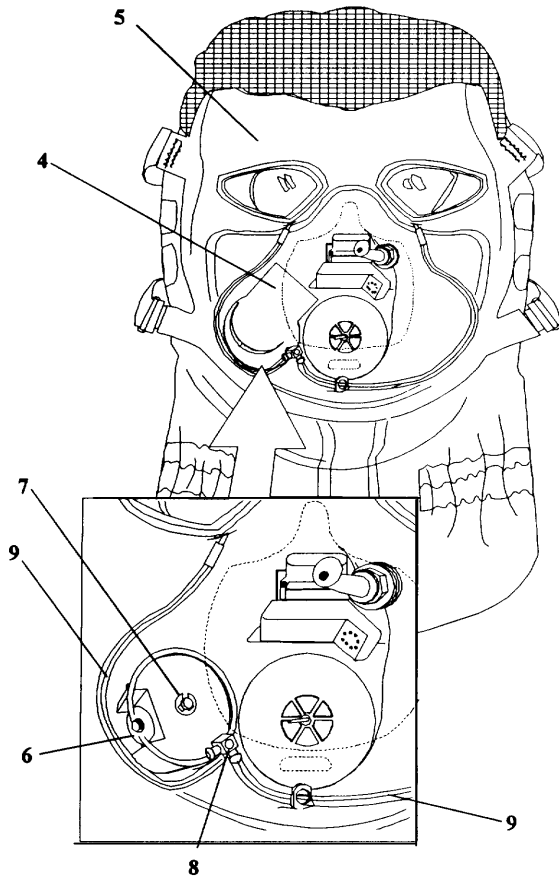

Table 2-1. PREVENTIVE MAINTENANCE CHECKS AND SERVICES FOR M48 MASK (CONT)

Item No.	Interval	Item to Check/Service	Procedure	Not Fully Mission Capable If;
			<p>4 Lift outlet valve cover (1) by pulling tab on top of cover out and up.</p> <p>b. Check that outlet valve disk (2) is present and is not curled or distorted. Rotate outlet valve disk to make sure it is not sticking.</p> <p>c. Check outlet valve disk for nicks, tears, or rips. Wipe off any moisture from valve disk with a soft, clean cheesecloth (Item 7, App D). Smooth disk with your finger so that it lies flat on outlet valve seat.</p> <p>d. Check outlet valve seat (3) for dirt, nicks or cracks.</p> <p>e. Check outlet valve cover for breaks, cracks, and missing hinge pin (4) or retaining ring (5).</p>	<p>Semi-Annual OUTLET VALVE ASSEMBLY cover a.</p> <p>WARNING Do not use facepiece assembly if valve disk is missing or damaged.</p> <p>Valve disk is missing, distorted, sticking or damaged.</p> <p>WARNING Do not use paper to remove dirt or moisture from outlet valve cover or outlet valve disk. Paper may break up and lodge in outlet valve causing valve to leak.</p> <p>Outlet valve disk is nicked, torn, or ripped; cannot be cleaned, or will not seat properly.</p> <p>Outlet valve seat is dirty, nicked or cracked.</p> <p>Outlet cover is broken or cracked. Hinge pin or retaining ring is missing.</p>

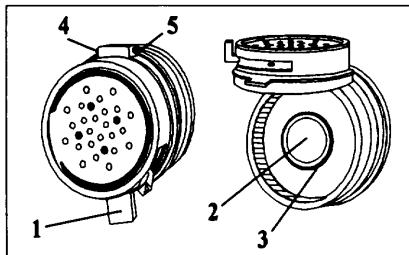

Table 2-1. PREVENTIVE MAINTENANCE CHECKS AND SERVICES FOR M48 MASK (CONT)

Item No.	Interval	Item to Check/Service	Procedure	Not Fully Mission Capable If;
5	Semi-Annual	VOICEMITTER	<p>a. Check retaining ring (1) on voicemitter (2) for corrosion, cracks, or nicks. Check retaining ring for looseness.</p> <p>b. Check voicemitter for dents, cracks, or punctures. Make sure punctured, missing, or installed voicemitter is not missing. Make sure the four pins (3) in the center of voicemitter are facing outward.</p> <p>c. Close outlet valve cover.</p>	<p>Retaining ring is corroded, cracked, nicked or loose.</p> <p>Voicemitter is dented, cracked, punctured, missing, or installed backwards.</p>

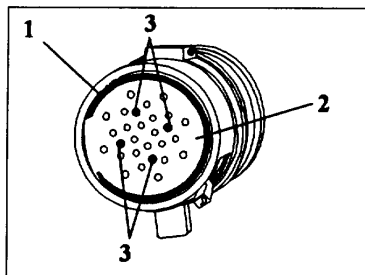

Table 2-1. PREVENTIVE MAINTENANCE CHECKS AND SERVICES FOR M48 MASK (CONT)

Item No.	Interval	Item to Check/Service	Procedure	Not Fully Mission Capable If;
6	Semi-Annual	LENSES	<ul style="list-style-type: none"> a. Check lenses (1) for cracks, cuts, scratches, or stains that affect vision. b. Check that mounting pins (2) are straight and mounted securely in lenses. c. If IPD staple (3) is required, ensure that it is present, the proper size and is not broken. d. Ensure retaining clips (4) are present and secure. e. If lens cushions (5) were installed, make sure they are securely attached without having edges folded up. 	<p>Lenses are cracked, cut, scratched, or have stains that affect vision.</p> <p>Mounting pins are bent or loose in lenses.</p> <p>IPD staple is missing, broken, or needs to be re-sized. See para 2-8 (12).</p> <p>Retaining clips are loose or missing.</p> <p>Lens cushions are loose or edges are folded up.</p>

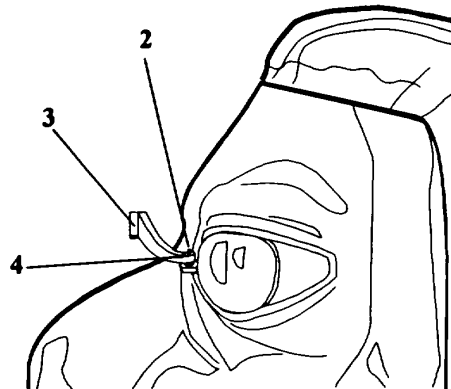
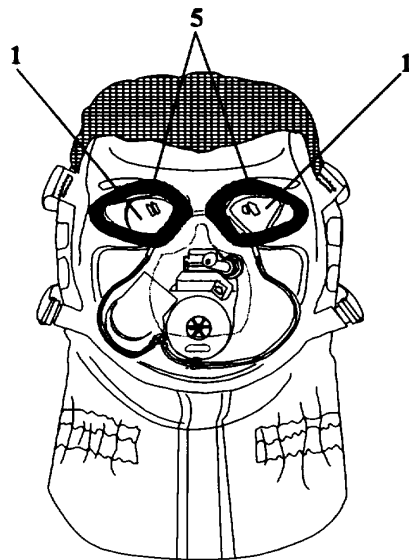

Table 2-1. PREVENTIVE MAINTENANCE CHECKS AND SERVICES FOR M48 MASK (CONT)

Item No.	Interval	Item to Check/Service	Procedure	Not Fully Mission Capable If;
7	Semi-Annual	DRINKING SYSTEM	<p>a. Check that internal drink tube (1) and external drink tube (2) are present. Look for cracks or cuts in internal and external drink tubes.</p> <p>b. Check flexibility of internal and external drink tubes.</p> <p>c. Ensure that internal drink tube is in front of microphone (3) and pin protector (4).</p> <p>d. Check that quick-disconnect coupling half (5) is not crushed, dented, corroded, or separated from external drink tube.</p> <p>e. Return quick-disconnect half (5) to pocket (6).</p>	<p>Internal or external drink tube is missing, cracked, or cut.</p> <p>Internal or external drink tube is not flexible.</p> <p>Internal drink tube is caught behind microphone or pin protector.</p> <p>Quick-disconnect coupling half is crushed, dented, corroded, or separated from external drink tube.</p>

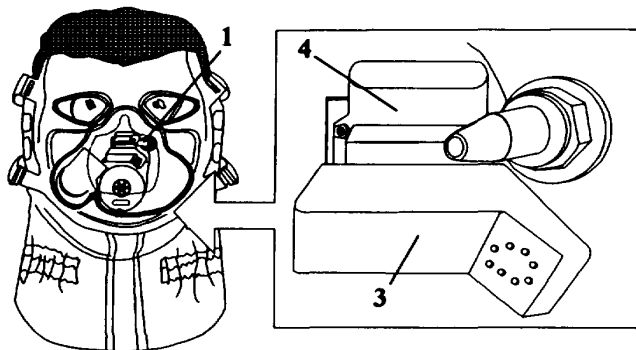
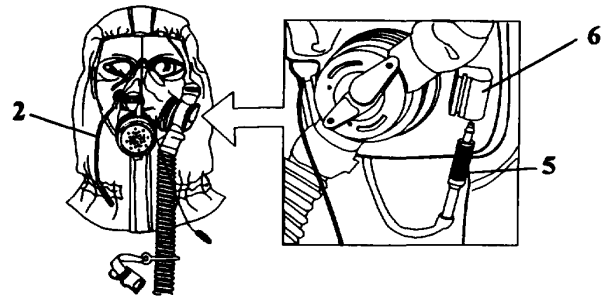

Table 2-1. PREVENTIVE MAINTENANCE CHECKS AND SERVICES FOR M48 MASK (CONT)

Item No.	Interval	Item to Check/Service	Procedure	Not Fully Mission Capable If;
8	Semi-Annual	MICROPHONE	<p>a. Check microphone (1) for cracked or broken housing.</p> <p>b. Check microphone adapter (2). Look for loose screws (3) or cracked or broken housing or tangs (4) and pin protector (5).</p> <p>c. Check microphone cable (6) for broken connectors, bare wires, or cut wires.</p>	<p>Microphone housing is cracked or broken.</p> <p>Screws are loose or missing. Housing or pin protector is cracked or broken.</p> <p>Connectors are broken, wires are bare or wires are cut.</p>

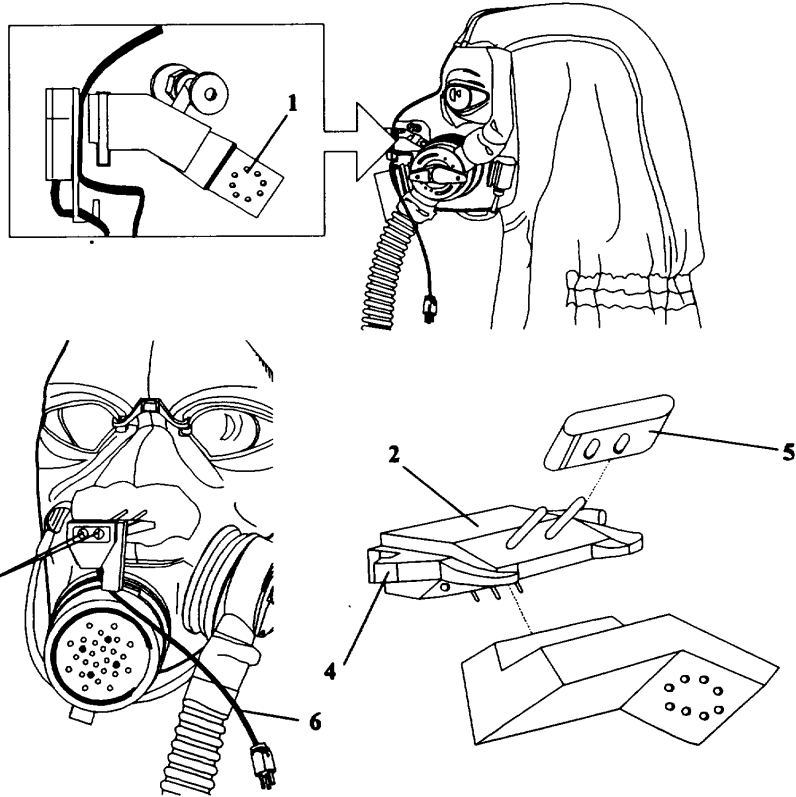

Table 2-1. PREVENTIVE MAINTENANCE CHECKS AND SERVICES FOR M48 MASK (CONT)

Item No.	Interval	Item to Check/Service	Procedure	Not Fully Mission Capable If;
9	Semi-Annual	HOSE	<ul style="list-style-type: none"> a. Check hose (1) for tears, cuts, or holes, and that it is not sticky or soft. b. Check that clamp (2) on each end of hose is secure. c. Check that swivel assembly (3) is not loose on hose, cracked, or broken; and that threads are clean and serviceable. d. Ensure the swivel assembly rotates but does not spin freely. e. Remove gasket (4) and make certain it is not torn, cut, or distorted. f. Reinstall gasket in the swivel assembly. 	<p>Hose has tears, cuts, holes or it has sticky or soft spots.</p> <p>Clamps are loose or missing.</p> <p>Swivel assembly is loose in hose, bent, cracked, or broken; or has threads that are unserviceable.</p> <p>Swivel assembly does not rotate or offers no resistance to being turned around.</p> <p>Gasket is missing, torn, cut, or distorted.</p>

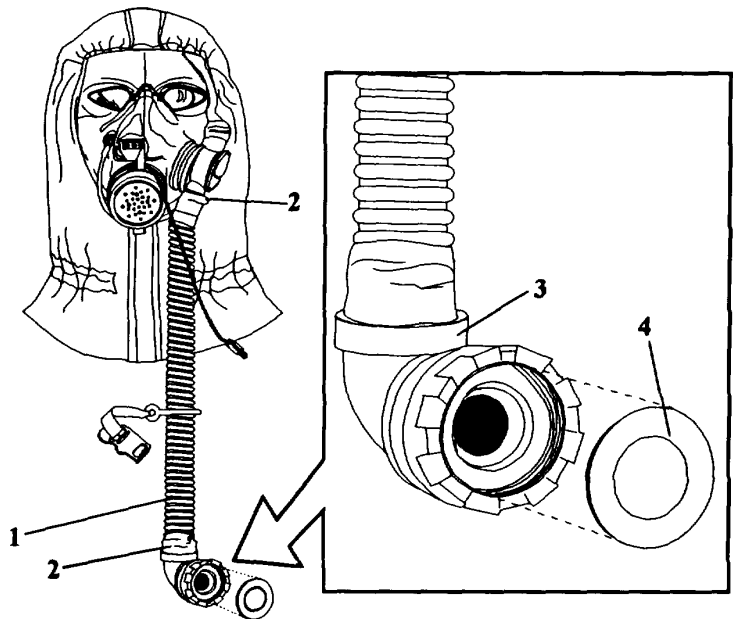

Table 2-1. PREVENTIVE MAINTENANCE CHECKS AND SERVICES FOR M48 MASK (CONT)

Item No.	Interval	Item to Check/Service	Procedure	Not Fully Mission Capable If;
10	Semi-Annual	CANISTERS	<p style="text-align: center;">WARNING</p> <p>HEALTH/ENVIRONMENTAL HAZARD. There are two Mask Filter Canisters, the C2 and the C2A1.</p> <p>The C2 canister contains Chromium VI and damaged or unusable canisters are considered Hazardous Waste. (Chromium VI is a known carcinogen if inhaled or swallowed.)</p> <p>The C2A1 canister is chromium-free but must continue to be disposed of in accordance with State and Local Environmental Laws.</p> <p>DO NOT throw away damaged or unusable canisters as ordinary trash .</p> <p>DO turn in damaged or unusable canisters to your hazardous waste management office or Defense Reutilization and Marketing Office (DRMO).</p> <p>a. Check canisters (1) for dented or deformed body, damaged threads, breaks, cracks, dirt in openings, moisture or water stains.</p> <p>b. Shake canisters and listen for loose particles.</p> <p>c. Check expiration date of canisters and canister replacement interval. Reinstall serviceable canisters. Screw a canister clockwise into each canister port until handtight.</p>	<p>Either canister is wet, crushed, split, cracked, clogged with dirt, or has water stains.</p> <p>Canister has loose particles that rattle or fall out when shaken.</p> <p>Canister replacement criteria is exceeded.</p> <p style="text-align: center;">NOTE</p> <p style="text-align: center;">Refer to Canister Replacement Criteria, Operator's Manual, TM 3-4240-342-10.</p> 

Table 2-1. PREVENTIVE MAINTENANCE CHECKS AND SERVICES FOR M48 MASK (CONT)

Item No.	Interval	Item to Check/Service	Procedure	Not Fully Mission Capable If;
11	Semi-Annual	BLOWER ASSEMBLY	<ul style="list-style-type: none"> a. Check blower (1) for cracks and breaks. b. Check that gaskets (2) are not cut, torn, or missing. c. Ensure threads are not stripped, cracked or damaged. d. Ensure that strap (3) and armband (4) are not cut, torn or missing. e. Ensure attaching hardware (5) is present and not damaged. f. Check that power switch (6) is present and not broken. g. Check belt loops (7) for cracks or damage. h. Ensure battery cap (8), spring (9), and lanyard (10) are securely attached and not damaged. 	<p>Blower is cracked or broken.</p> <p>Gaskets are cut, torn, or missing.</p> <p>Threads are stripped, cracked or damaged.</p> <p>Strap or armband is cut, tom or missing.</p> <p>Attaching hardware is damaged or missing.</p> <p>Switch is missing or broken.</p> <p>Belt loops are cracked or damaged.</p> <p>Battery cap, spring, or lanyard are not securely attached or damaged.</p>

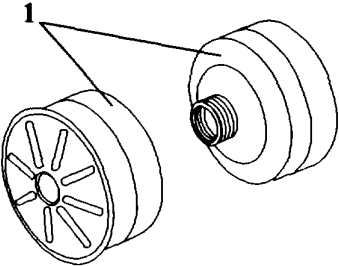
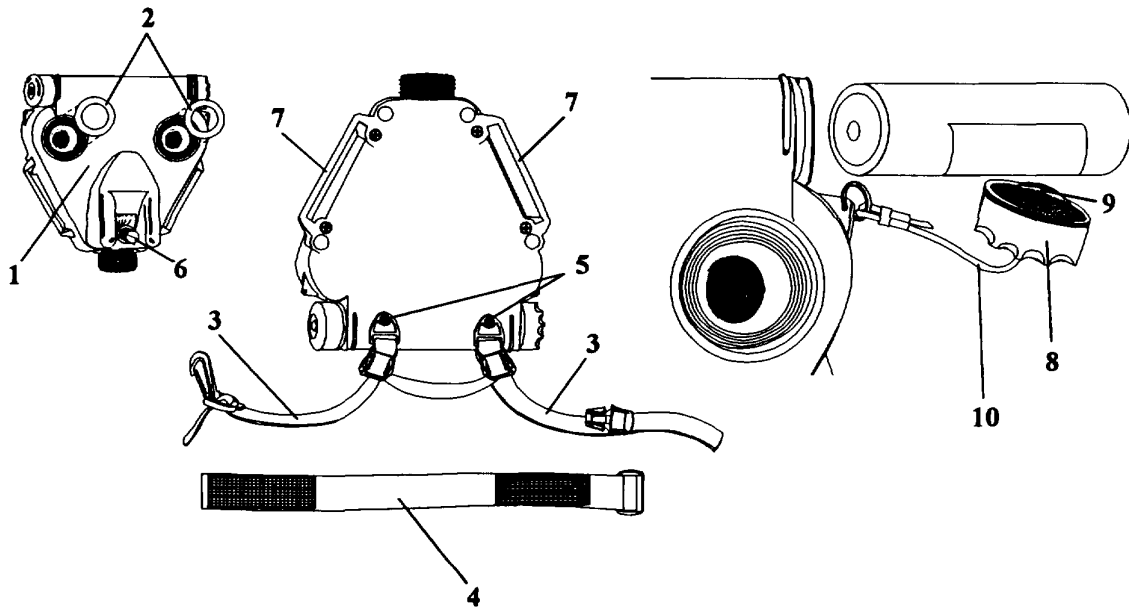

Table 2-1. PREVENTIVE MAINTENANCE CHECKS AND SERVICES FOR M48 MASK (CONT)

Item No.	Interval	Item to Check/Service	Procedure	Not Fully Mission Capable If;
12	Semi-Annual	BATTERIES	<p style="text-align: center;">WARNING</p> <p>Lithium-sulfur dioxide (LiSO₂) batteries which are used in this equipment contain pressurized sulfur dioxide (SO₂) gas. The gas is toxic, and the battery MUST NOT be abused in any way which may cause the battery to rupture.</p> <p>A hissing sound from the battery or the smell of vinegar or rotten eggs indicates a leaking battery. If a leaking battery is detected, move battery to a well ventilated storage area and contact Defense Reutilization and Marketing Office for disposal</p> <p style="text-align: center;">CAUTION</p> <p>Remove batteries if blower is to be stored 30 days or more.</p> <p style="text-align: center;">NOTE</p> <p>Replace bad batteries. Be sure battery is new and has only been used for brief periods while checking blower assembly.</p> <p>a. Open battery cap (1) and remove battery (2) from blower assembly. Remove spare battery from carrier. Check each battery for leaks or cracks.</p> <p>b. Install spare battery from carrier into blower assembly. Turn switch (3) through the different speeds to ensure operation of blower</p>	<p>Material is leaking from battery, or battery case is cracked, broken, bulging, swelling or corroded.</p> <p>Battery does not operate blower.</p>

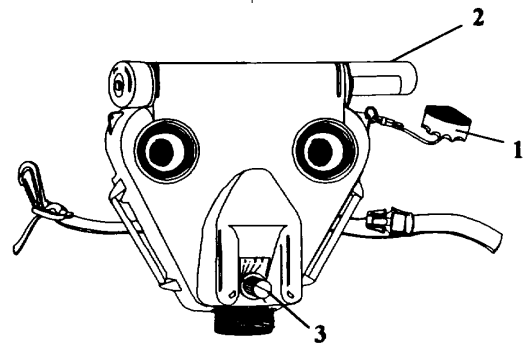

Table 2-1. PREVENTIVE MAINTENANCE CHECKS AND SERVICES FOR M48 MASK (CONT)

Item No.	Interval	Item to Check/Service	Procedure	Not Fully Mission Capable If;
13	Semi-Annual	WEB BELT	a. Check web bet (1) for cut or frayed webbing, and for missing buckle (2) or clip (3).	Web belt is cut or frayed, or clip or buckle is missing.

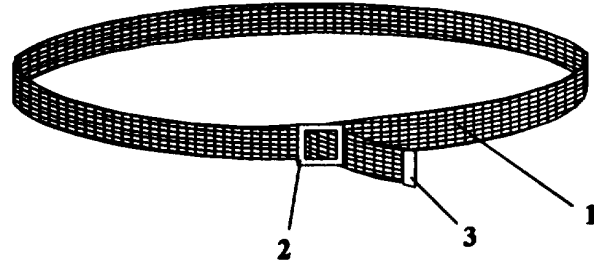

Table 2-1. PREVENTIVE MAINTENANCE CHECKS AND SERVICES FOR M48 MASK (CONT)

Item No.	Interval	Item to Check/Service	Procedure	Not Fully Mission Capable If;
14	Semi-Annual	FACEPIECE CARRIER	<p>a. Empty the facepiece carrier (1) and check for dirt, sharp edges, torn straps, or missing hardware.</p> <p>b. Make sure facepiece assembly (2) and faceform (3) are present, and no unauthorized material is inside or on carrier.</p> <p style="text-align: center;">NOTE. Insert faceform in facepiece assembly if mask is to be stored for 30 days or longer.</p>	<p>Straps are torn or hardware is missing. There are sharp edges inside carrier that could damage mask.</p> <p>Facepiece and/or faceform is missing, or unauthorized equipment is carried inside carrier.</p>

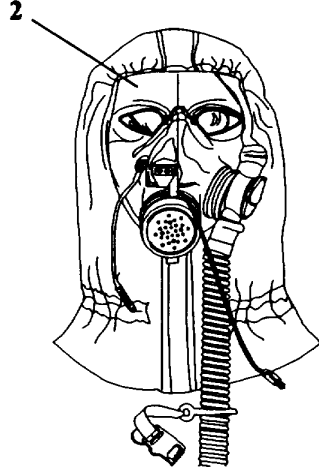
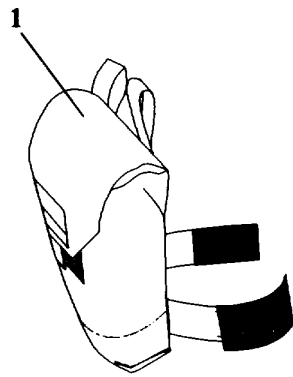
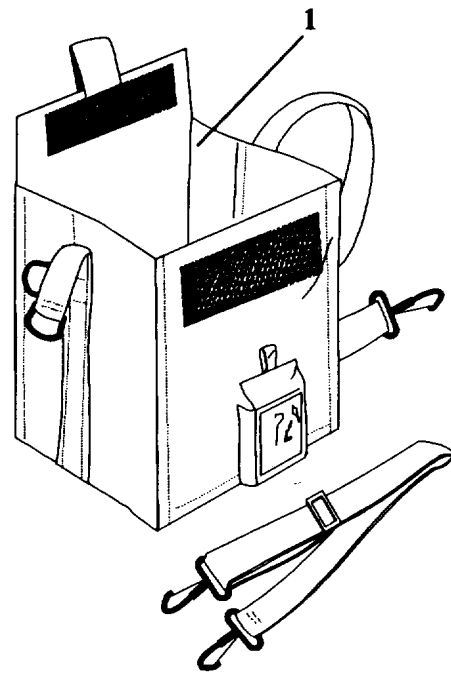

Table 2-1. PREVENTIVE MAINTENANCE CHECKS AND SERVICES FOR M48 MASK (CONT)

Item No.	Interval	Item to Check/Service	Procedure	Not Fully Mission Capable If;
15	Semi-Annual	MASK CARRIER	<p>a. Empty the carrier (1) and check for dirt, sharp edges, torn straps, or missing hardware.</p> <p>b. Make sure all authorized equipment is unauthorized material. unauthorized equipment is carried inside carrier.</p> <p style="text-align: center;">NOTE Stow mask and Additional Authorized List (AAL) items in carrier as described in operating procedures, Operators Manual TM 3-4240-342-10.</p>	<p>Straps are torn or hardware is missing. There are sharp edges inside carrier that could damage mask.</p> <p>Authorized equipment per para 2-2e of Operations Manual, TM 3-4240-342-10, is missing, or</p>



Section V. TROUBLESHOOTING

2-13. TROUBLESHOOTING.

Refer to Table 2-2, Maintenance Action Precise Symptom (MAPS) List, to determine which troubleshooting chart to use for a particular fault.

Table 2-2. Maintenance Action Precise Symptom (MAPS) List

TROUBLESHOOTING TABLE	SYMPTOM PAGE	NUMBER
	AIR SUPPLY	
	Insufficient/No Air to User	2-36
	Poor/No Lens Defogging	2-38
	Poor/No Hood Ventilation	2-39
	COMMUNICATION SYSTEM	
	Microphone Inoperative	2-40

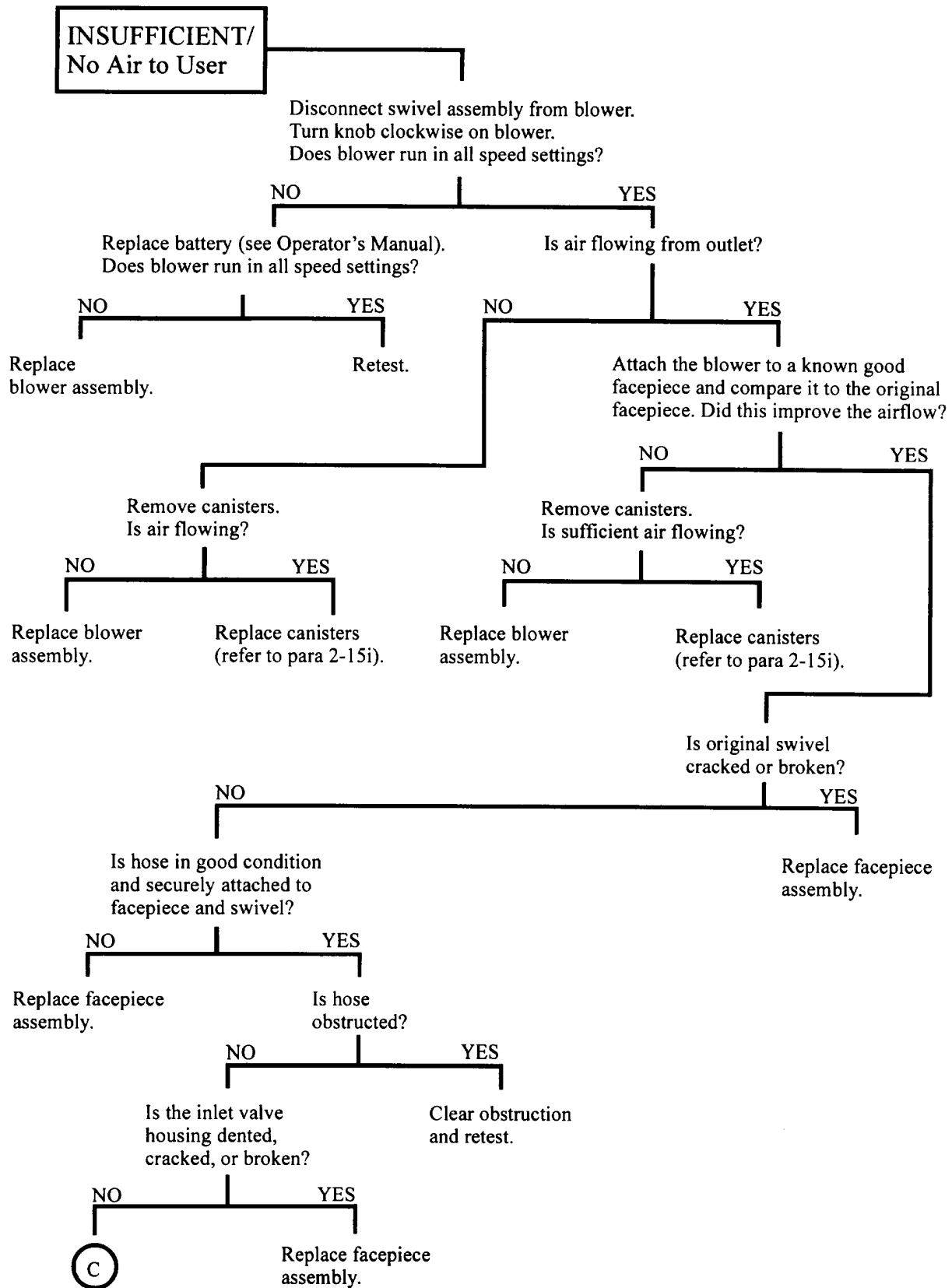

Table 2-3. Troubleshooting Chart - Insufficient/No Air to User

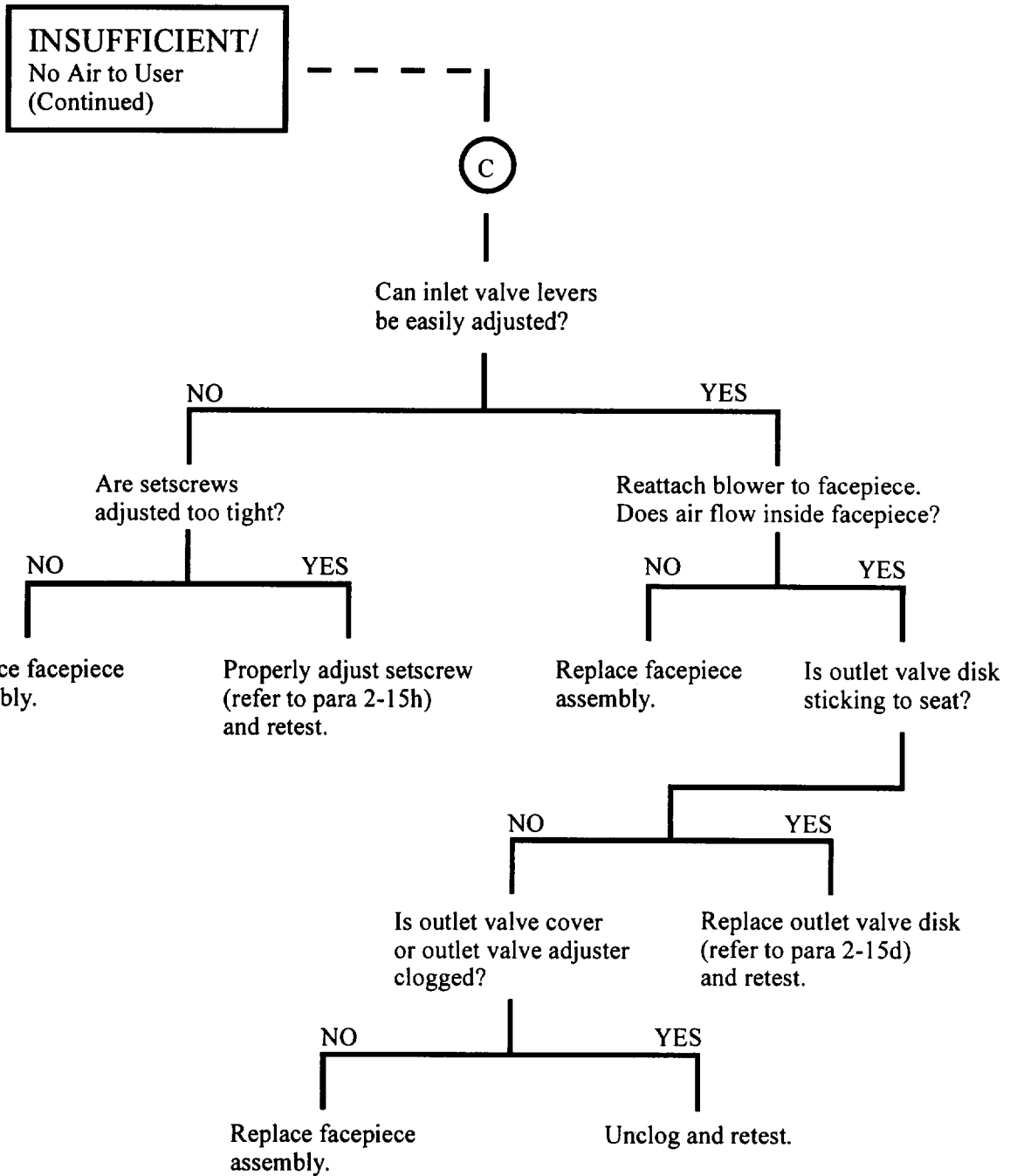

Table 2-4. Troubleshooting Chart -Poor /No Lens Defogging

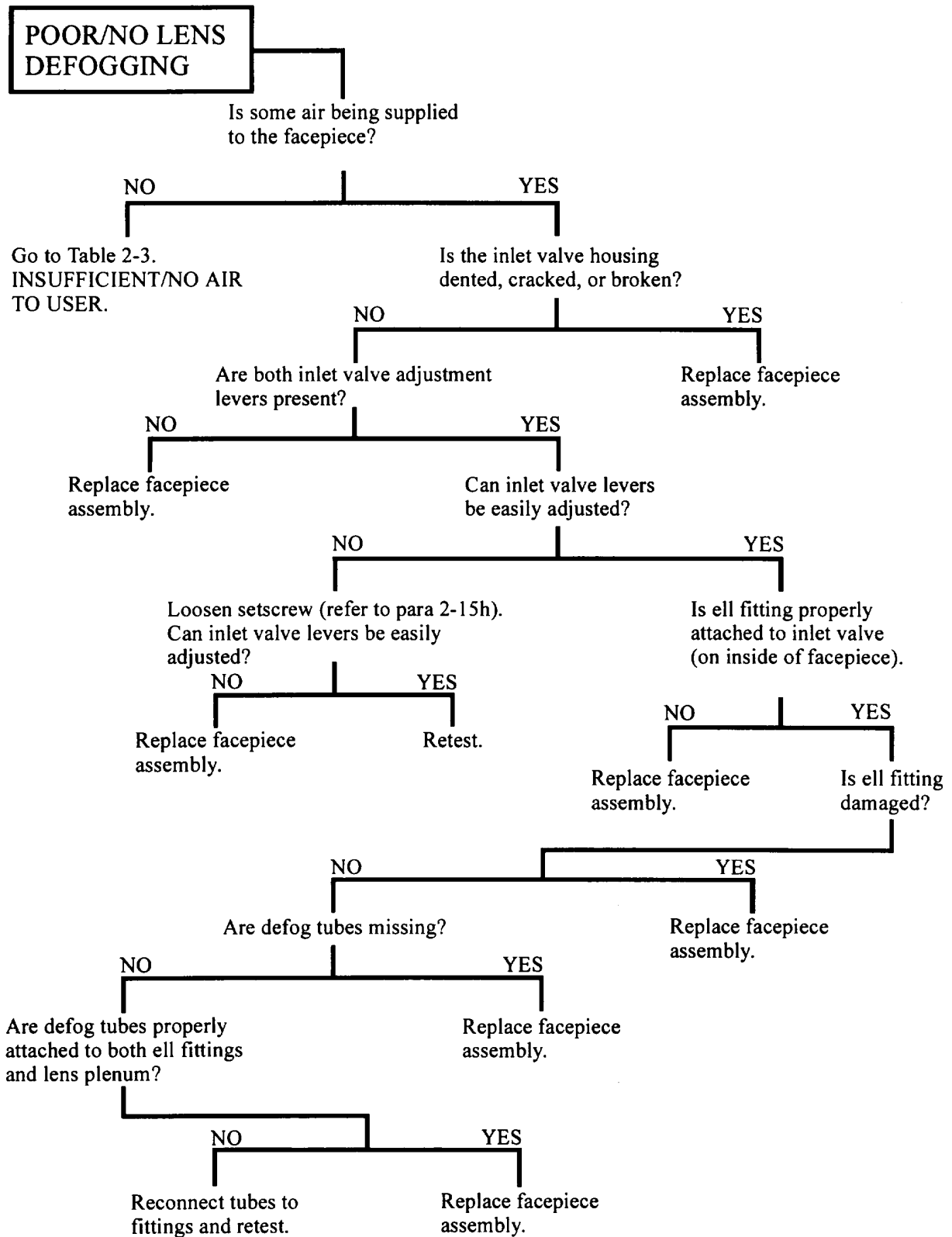

Table 2-5. Troubleshooting Chart -Poor /No Hood Ventilation

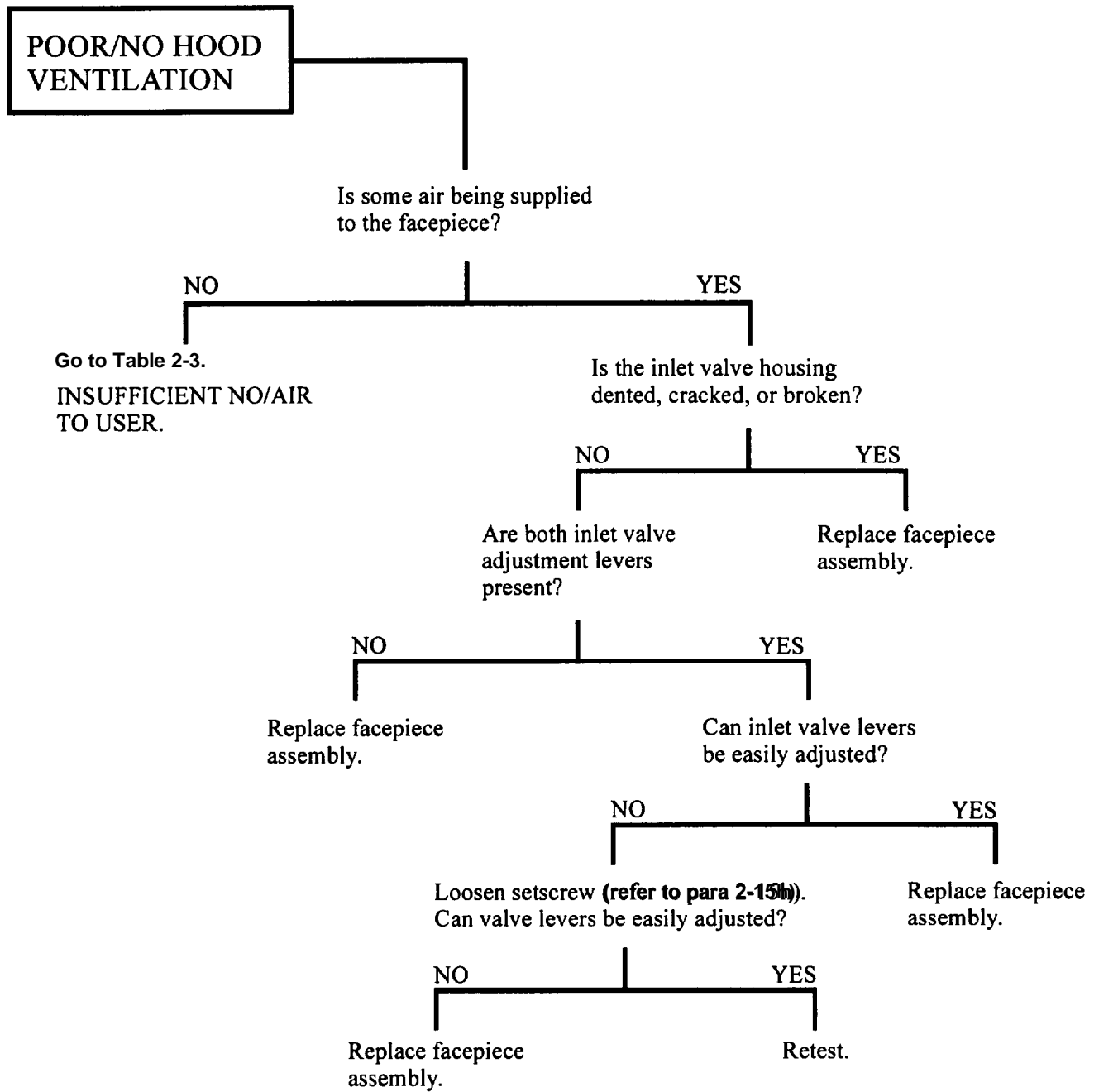
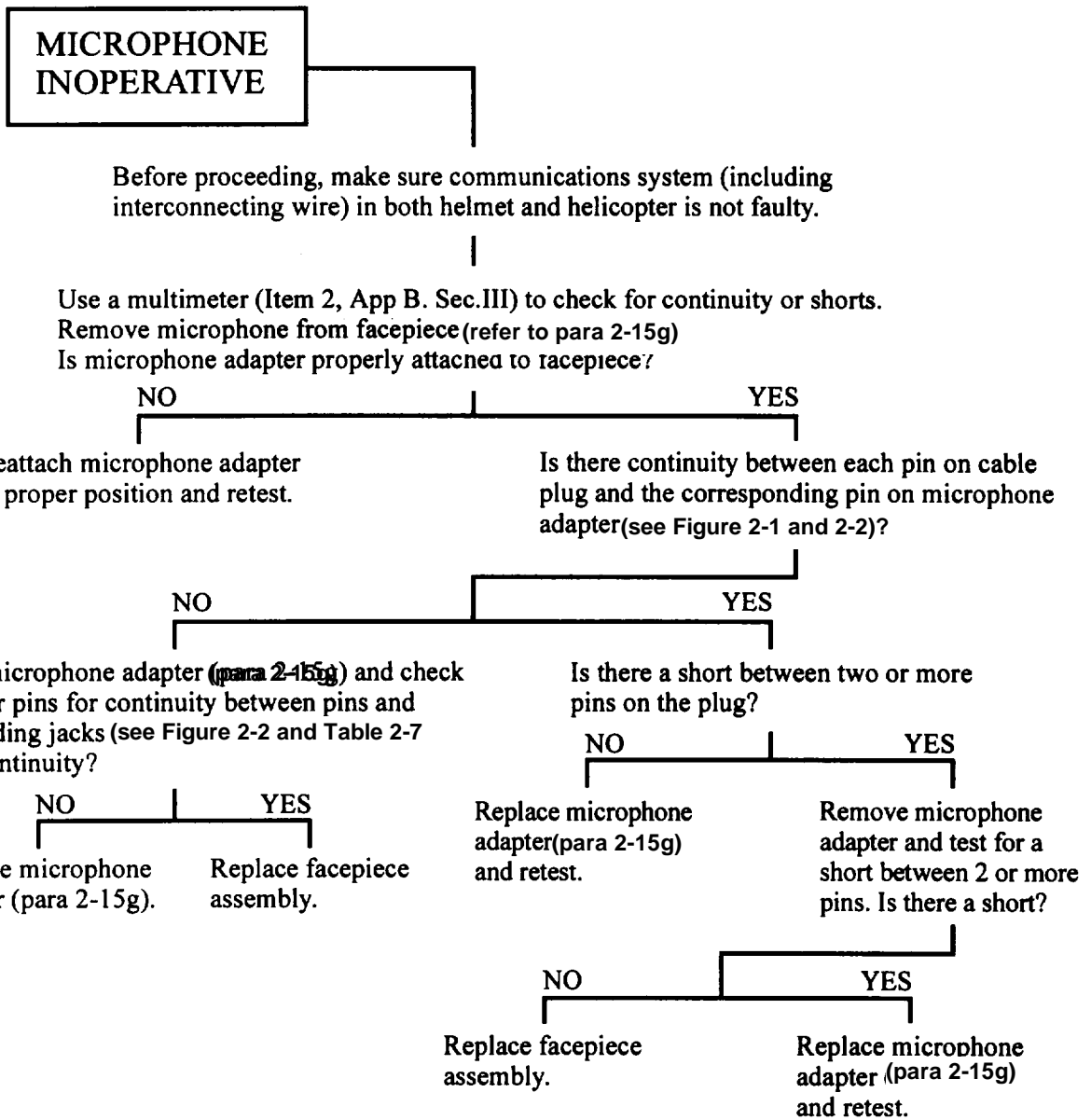

Table 2-6. Troubleshooting Chart -Microphone Inoperative



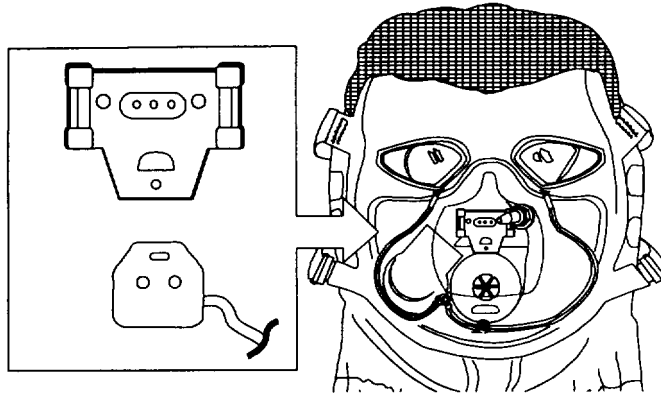

Figure 2-1. Cable Interconnection Diagram

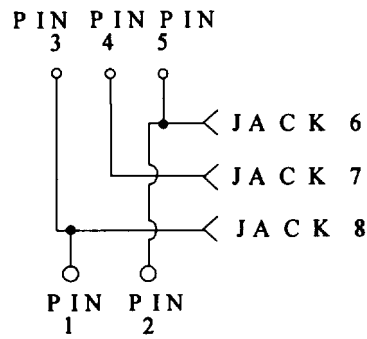

Figure 2-2. Pin/Jack Interconnection Diagram

PIN	JACK
1	8
2	6
3	8
4	7
5	6

Table 2-7. Pin/Jack Interconnection Diagram

2-41(2-42 blank)

Section VI. MAINTENANCE PROCEDURES

2-14. GENERAL.

The maintenance procedures in this section are to be performed by a unit maintenance technician or by the user under Unit Maintenance supervision. This section contains detailed maintenance procedures for the following component repair or replacement.

PARA	PROCEDURE	PAGE
2-15. MASK ASSEMBLY ADJUSTMENT, INSPECTION, AND REPAIR		2-44
a.	Facepiece Hood Repair	2-44
b.	Eyelens Cushion Replacement	2-46
c.	Internal Drink Tube Replacement	2-47
d.	Outlet Valve Disk Replacement	2-48
e.	Voicemitter Replacement	2-49
f.	Outlet Valve Cover Replacement	2-50
g.	Linear Microphone and Microphone Adapter Replacement	2-51
h.	Setscrew Adjustment and Replacement.....	2-53
i.	Canister Inspection and Replacement.....	2-54
j.	Swivel Assembly Gasket Replacement.....	2-55
k.	Mask Carrier Strap Replacement	2-56
2-16. BLOWER ASSEMBLY REPAIR		2-57
a.	Control Knob Replacement.....	2-57
b.	Port Gasket Replacement.....	2-59
c.	Strap Replacement	2-60
d.	Recess Caps Replacement.....	2-61
e.	Battery Cap Assembly Replacement.....	2-61

2-15. MASK ASSEMBLY ADJUSTMENT, INSPECTION, AND REPAIR.

This task covers:

- | | |
|------------------------------------|---|
| a. Facepiece Hood Repair | g. Linear Microphone and Microphone Adapter Replacement |
| b. Eyelens Cushion Replacement | h. Setscrew Adjustment and Replacement |
| c. Internal Drink Tube Replacement | i. Canister Inspection and Replacement |
| d. Outlet Valve Disk Replacement | j. Swivel Assembly Gasket Replacement |
| e. Voicemitter Replacement | k. Mask Carrier Strap Replacement |
| f. Outlet Valve Cover Replacement | |
-

a. Facepiece Hood Repair.

INITIAL SETUP

Materials/Parts

Maintenance Kit, Toxicological Agent
 Protective Clothing (Item 12, App D)
 Cheesecloth (Item 7, App D)

Equipment Condition

Swivel Assembly detached from blower.

WARNING

Hood repair procedures include the following restrictions. Protection will be degraded if any of the following conditions exist.

Do not attempt to repair facepiece hood if it is separated from faceblank. Replace facepiece assembly.

Do not patch the hood more than three times.

Do not overlap patches.

Do not repair hood if:

- Tears are longer than one inch
- Holes are larger than 1 inch
- Holes are larger than 1 inch in diameter
- Tears or holes are less than 2 inches apart
- Tears or holes are on strapped seams
- Tears or holes are within 2 inches of the faceblank

REPAIR

CAUTION

When performing maintenance on the mask, do not scratch the plastic lenses. Keep work area clean. Dirt in or on items could prevent airtight integrity.

1. Locate chafed, torn, or punctured area on hood.

2. Clean and dry damaged area with dry cloth.
3. Buff area lightly but thoroughly with abrasive strip (1).

NOTE

Buffed area should be slightly larger than the patch.

4. Wipe off loose dust with a clean dry cheesecloth.

WARNING

Use adhesive only in well-ventilated area and avoid contact with skin. Exposure to adhesive or adhesive vapor can be hazardous to your health.

NOTE

Be sure area to be patched is wrinkle-free and is placed on a flat surface.

5. Apply moderate coat of adhesive (2) directly to buffed area and spread evenly.
6. Let adhesive dry for 5 minutes (10 minutes in freezing temperatures).
7. Remove backing (3) from patch.
8. Position newly uncovered side (4) over the buffed damaged area and press into place.
9. Apply a second patch to the other side of the damaged area, repeating steps 1 through 8.

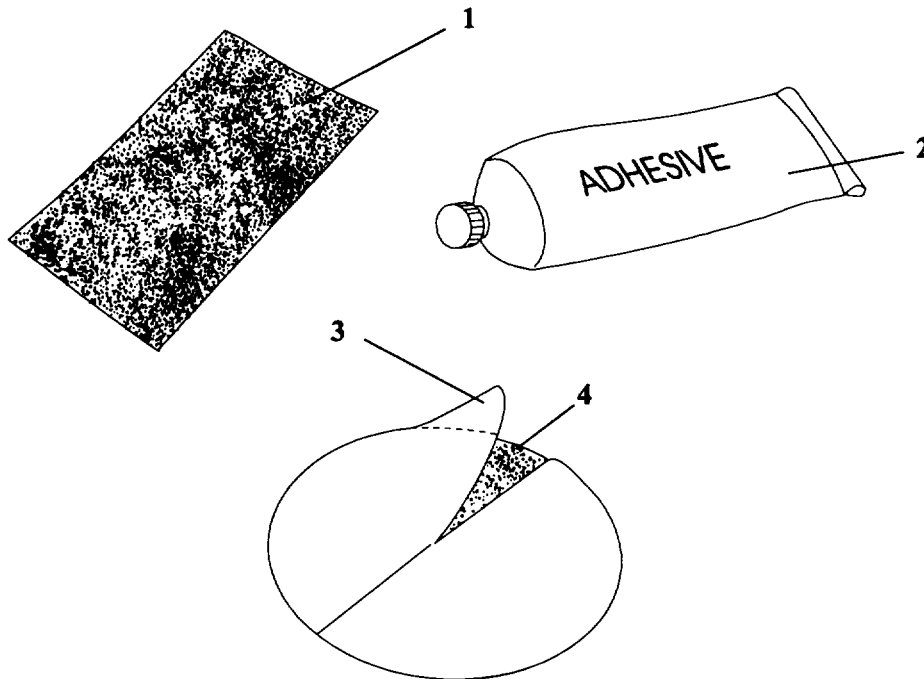

2-15. MASK ASSEMBLY ADJUSTMENT, INSPECTION, AND REPAIR (CONT).**b. Eyelens Cushion Replacement.**

INITIAL SETUP**Materials/Parts**

Isopropyl Alcohol (Item 10, App D)
Cheesecloth (Item 7, App D)

REMOVAL**CAUTION**

When performing maintenance on the facepiece assembly, do not scratch the plastic lenses.

Keep work area clean.

1. Gently peel eyelens cushions (1) away from eyelens (2) and facepiece.
2. Use a clean, lint-free cheesecloth and isopropyl alcohol to remove residual adhesive from facepiece assembly.
3. Be sure that the eyelens cushion attaching surface on the facepiece assembly is free of dirt and old adhesive.

INSTALLATION

1. Remove protective paper from eyelens cushion adhesive.

NOTE

Use care when positioning the new eyes lens cushion. Be sure position is correct before pressing into place.

2. Position eyelens cushion (1) inside faceplate around the eyelens (2) and press into place.

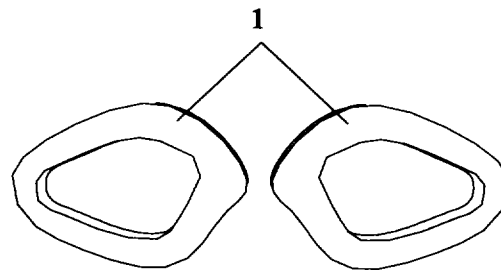
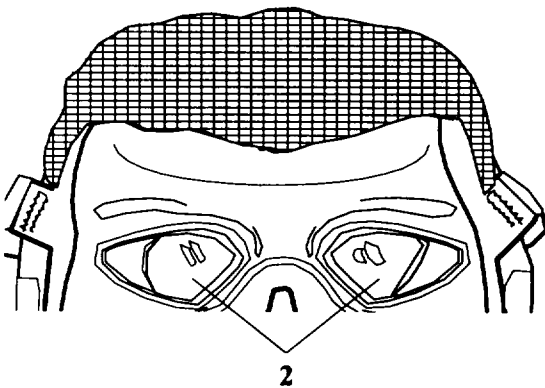

c. Internal Drink Tube Replacement.**INITIAL SETUP****Materials/Parts**

Isopropyl Alcohol (Item 10, App D)

Cheesecloth (Item 7, App D)

REMOVAL**CAUTION**

When performing maintenance on the facepiece assembly, do not scratch the plastic lenses.

Keep work area clean. Dirt in or on items could prevent airtight integrity.

1. Pull old internal drink tube (1) off drink tube pass-through assembly (2).
2. Use a clean, lint-free cheesecloth and isopropyl alcohol to thoroughly clean barbed end of drink tube pass-through assembly.

INSTALLATION**NOTE**

Bulbous end of the drink tube is away from drink tube passthrough assembly.

Do not use adhesive when installing internal drink tube assembly.

1. Slide plain end of drink tube (1) onto barbed end of drink tube pass-through assembly (2) until drink tube seats against shoulder.
2. Test drinking system as described in Operator's Manual, TM 3-4240-342-10.

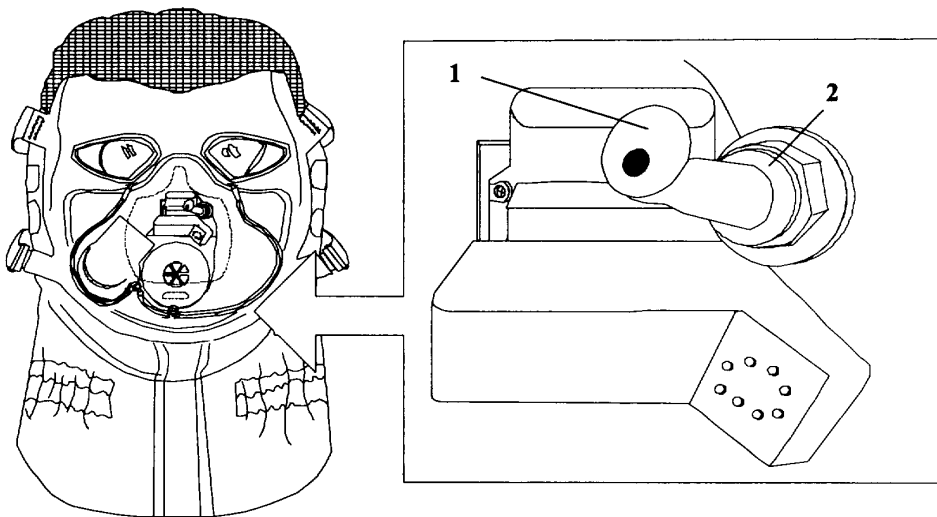

2-15. MASK ASSEMBLY ADJUSTMENT, INSPECTION, AND REPAIR (CONT).**d. Outlet Valve Disk Replacement.**

INITIAL SETUP**Materials/Parts**None.

REMOVAL**CAUTION**

When performing maintenance on the facepiece assembly, do not scratch the plastic lenses.

Keep work area clean. Dirt in or on items could prevent airtight integrity.

1. Grip tab on bottom of valve cover (1) and pull up.
2. Pinch valve disk (2) between thumb and forefinger and pull out to remove valve disk from valve seat (3).
3. Use finger to wipe inside valve seat to remove any foreign matter.

INSTALLATION

1. Insert valve disk shaft (4) into hole (5) in center of valve seat. Reach inside nosecup to grab shaft, and pull shaft through hole until it pops into place.
2. Grab tab on bottom of outlet valve assembly cover and close outlet valve assembly cover.

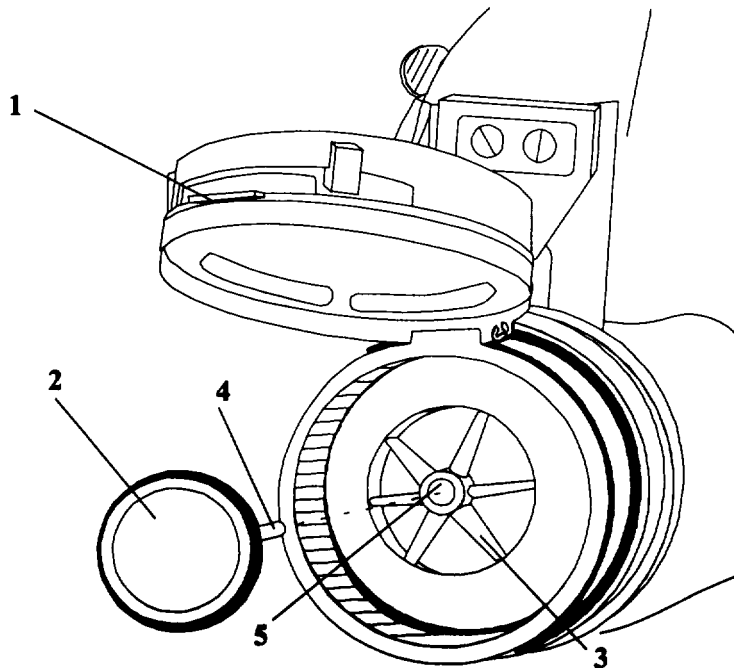

e. Voicemitter Replacement.

INITIAL SETUP

Tools

Tool Kit, Electronic Equipment
TK 105G (Item 1, App B, Sect. III)

REMOVAL

CAUTION

When performing maintenance on the facepiece assembly, do not scratch the plastic lenses. Keep work area clean. Dirt in or on items could prevent airtight integrity.

1. Pry tapered end of retaining ring (1) out of outlet valve cover (2).
2. Work retaining ring out of groove in outlet valve cover.
3. Carefully remove voicemitter (3).
4. Remove voicemitter gasket (4).

INSTALLATION

NOTE

Make sure gasket is laying flat in outlet valve cover.

1. Insert new gasket (4) into outlet valve cover.

NOTE

Make sure four pins near center of voicemitter are pointing out.

2. Install voicemitter (3) in outlet valve cover.
3. Insert one end of retaining ring in groove in outlet valve cover and hold in place.
4. Work retaining ring into groove until fully seated.

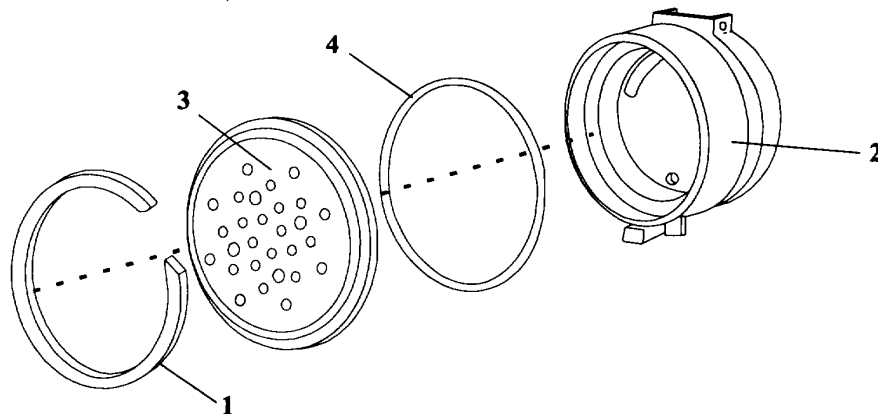

2-15. MASK ASSEMBLY ADJUSTMENT, INSPECTION, AND REPAIR (CONT).**f. Outlet Valve Cover Replacement.****INITIAL SETUP****Tools**

Tool Kit, Electronic Equipment
TK 105G (Item 1, App B, Sect. III)

Materials/Parts

Headed Grooved Pin 1 ea. PN 5-1-1370
Retaining Ring 1 ea. PN MS 16633-4006

REMOVAL**CAUTION**

When performing maintenance on the facepiece assembly, do not scratch the plastic lenses.

Keep work area clean. Dirt in or on items could prevent airtight integrity.

1. Remove voicemitter (1) as described in para 2-15e, Voicemitter Replacement.
2. Pull retaining ring (2) off valve cover pin (3) and discard retaining ring.
3. Remove valve cover pin and retain if reusable.
4. Remove old valve cover.

INSTALLATION

1. Snap new outlet valve cover into position on outlet valve assembly.
2. Insert pin into place.
3. Snap new retaining ring on to pin.

NOTE

Ensure the four pins on voicemitter face away from facepiece assembly.

4. Install voicemitter as described in para 2-15e, Voicemitter Replacement.
5. Make sure voicemitter side of cover is facing away from facepiece.
6. Make sure outlet valve cover opens and closes freely, voicemitter functions properly, and outlet valve assembly flow control moves freely.

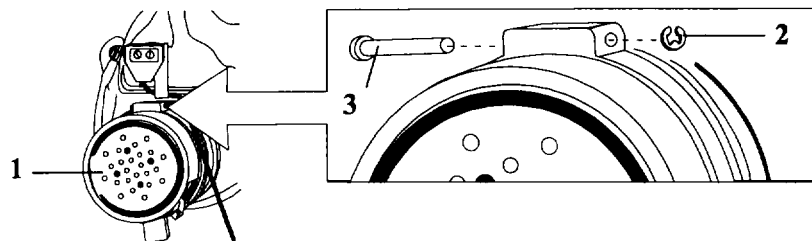

g. Linear Microphone and Microphone Adapter Replacement.

INITIAL SETUP

Tools

Tool Kit, Electronic Equipment TK 105G
(Item 1, App B, Sect. III)

Equipment Conditions

Suspension harness over front of facepiece assembly.

REMOVAL

CAUTION

When performing maintenance on the facepiece assembly, do not scratch the plastic lenses.

Keep work area clean. Dirt in or on items could prevent airtight integrity.

1. Push in tangs (1) on side of microphone adapter (2) to release from facepiece assembly attachment (3) and remove microphone and adapter.
2. Remove two screws (4) attaching microphone (5) to adapter, and separate microphone from adapter.

NOTE

Save pin protector. It will be reinstalled later.

3. Remove pin protector (6).

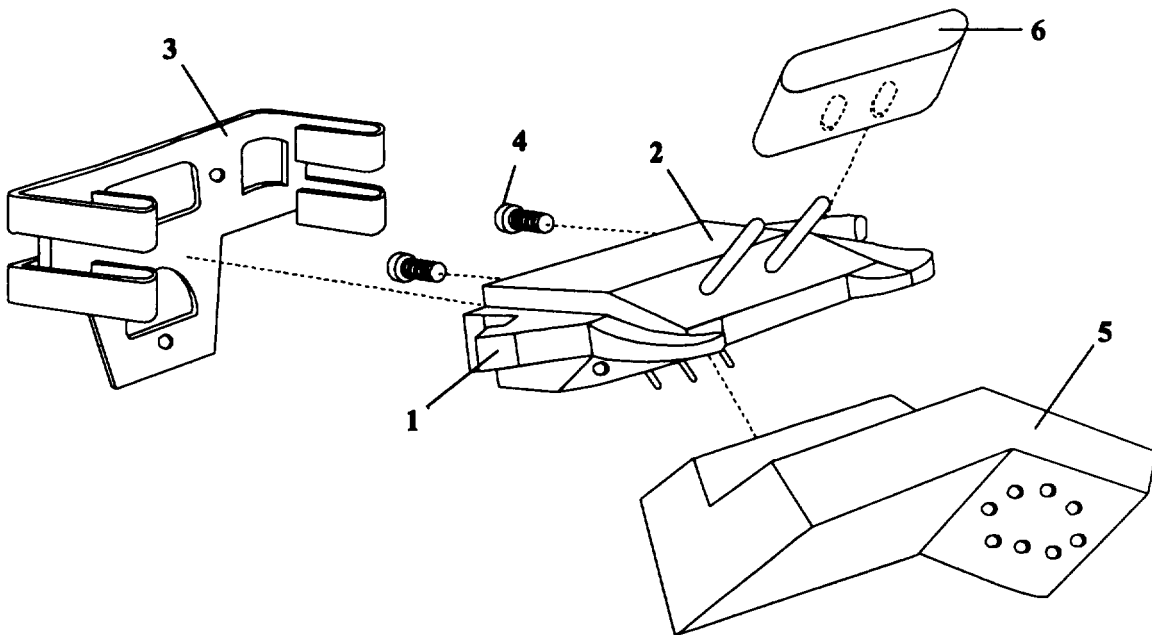

2-15. MASK ASSEMBLY ADJUSTMENT, INSPECTION, AND REPAIR (CONT).

g. Linear Microphone and Microphone Adapter Replacement (Cont).

INSTALLATION

NOTE

The microphone should be installed with the projecting arm to the right side of the soldier's mouth.

1. Attach microphone (5) to adapter (2).
2. Install pin protector (6).
3. Insert and tighten the screws (4) securing microphone to adapter.

CAUTION

Attach the adapter carefully to prevent binding or breaking connector pins.

4. Attach the adapter to the facepiece assembly, attachment (3).

NOTE

The microphone should be angled toward the chin of the facepiece assembly.

Make sure pin protector is in place on pins that are not used.

5. Fold suspension harness to back of facepiece assembly.

FOLLOW-ON MAINTENANCE

Test the microphone using the communications system in the aircraft.

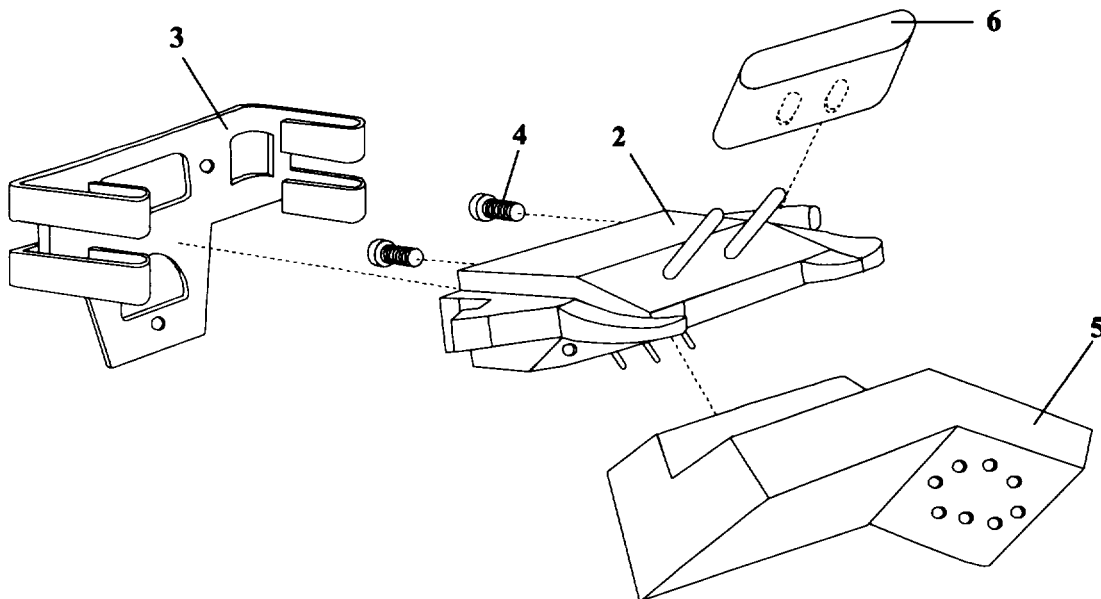

h. Setscrew Adjustment and Replacement.

INITIAL SETUP

Tools

Tool Kit, Electronic Equipment
TK 105G (Item 1, App B, Sect. III)

CAUTION

When performing maintenance on the facepiece, do not scratch the plastic lenses.

Keep work area clean. Dirt in or on items could prevent airtight integrity.

REMOVAL

Unscrew setscrew (1) from lever (2).

INSTALLATION

NOTE

Do not use thread glue. A nylon locking device is built into the setscrew.

Screw setscrew into lever.

ADJUSTMENT

NOTE

Proper adjustment of setscrew permits easy adjustment of levers.

Turn screw in to tighten or out to loosen setscrew as necessary.

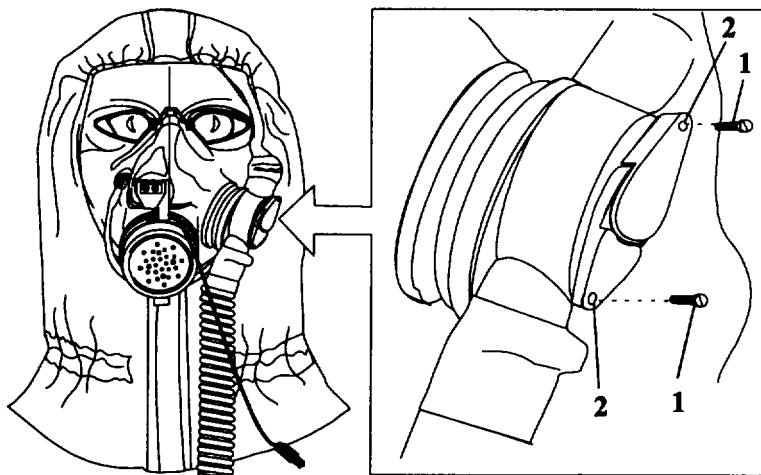

2-15. MASK ASSEMBLY ADJUSTMENT, INSPECTION, AND REPAIR (CONT).**i. Canister Inspection and Replacement.****INITIAL SETUP****Materials/Parts**

Cheesecloth (Item 7, App D)
atmosphere

Special Environmental Conditions

Canisters shall be changed only in a nontoxic

]

WARNING

HEALTH/ENVIRONMENTAL HAZARD. There are two Mask Filter Canisters, the C2 and the C2AI.

The C2 canister contains Chromium VI and damaged or unusable canisters are considered Hazardous Waste. (Chromium VI is a known carcinogen if inhaled or swallowed.) The C2AI canister is chromium-free but must continue to be disposed of in accordance with State and Local Environmental Laws.

DO NOT throw away damaged or unusable canisters as ordinary trash.

DO turn in damaged or unusable canisters to your hazardous waste management office or Defense Reutilization and Marketing Office (DRMO).

REMOVAL

Unscrew canisters (1) counterclockwise from blower (2).

INSPECTION

1. Check canisters for dented or deformed body, damaged threads, breaks or cracks, or dirt in openings.
2. Check that gasket (3) is present in each side of blower. If missing, see para 2-16b.

INSTALLATION

Screw a canister clockwise into each port of blower until hand tight.

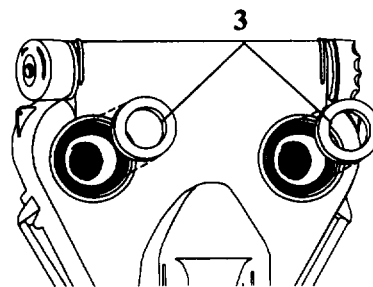
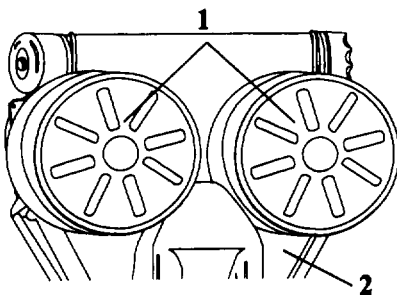

j. Swivel Assembly Gaskets Replacement.

INITIAL SETUP

Equipment Condition

Swivel assembly disconnected from blower.

REMOVAL

Remove gasket (1) from swivel (2) and discard.

INSTALLATION

1. Place gasket in swivel.

WARNING

Proper installation of gasket is critical for proper function.

CAUTION

Do not use sharp implements to install gasket. It may damage gasket.

2. Work gasket into groove until fully seated.

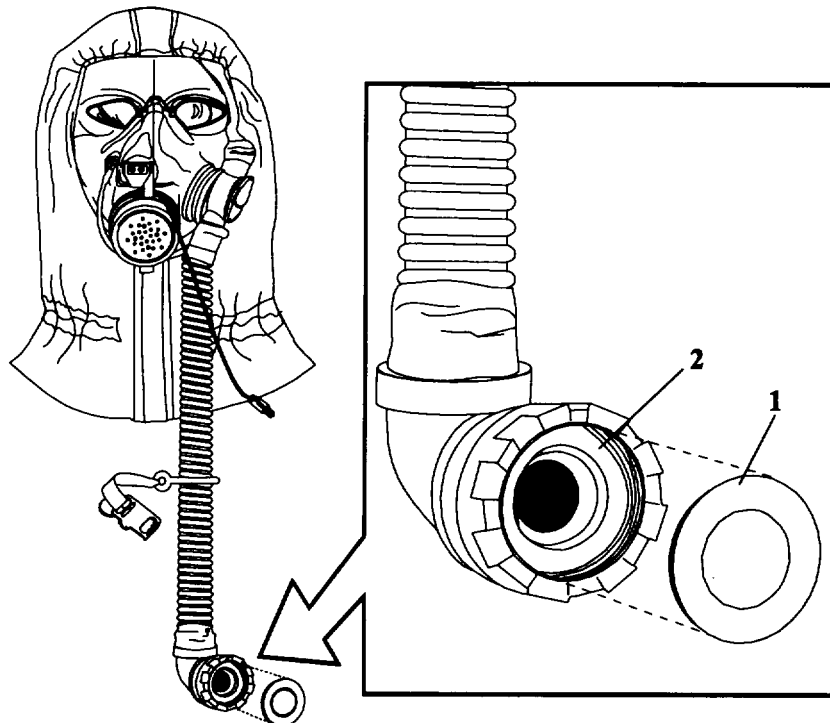

2-15. MASK ASSEMBLY ADJUSTMENT, INSPECTION, AND REPAIR (CONT).**k. Mask Carrier Strap Replacement.****INITIAL SETUP****Tools**

None.

REMOVAL

Unclip waist strap (1) and remove from carrier.

INSTALLATION

1. Clip new waist strap (1) to carrier attachment D-rings (2).
2. Don carrier and adjust waist strap as described in Operator's Manual, TM 3-4240-342-10.

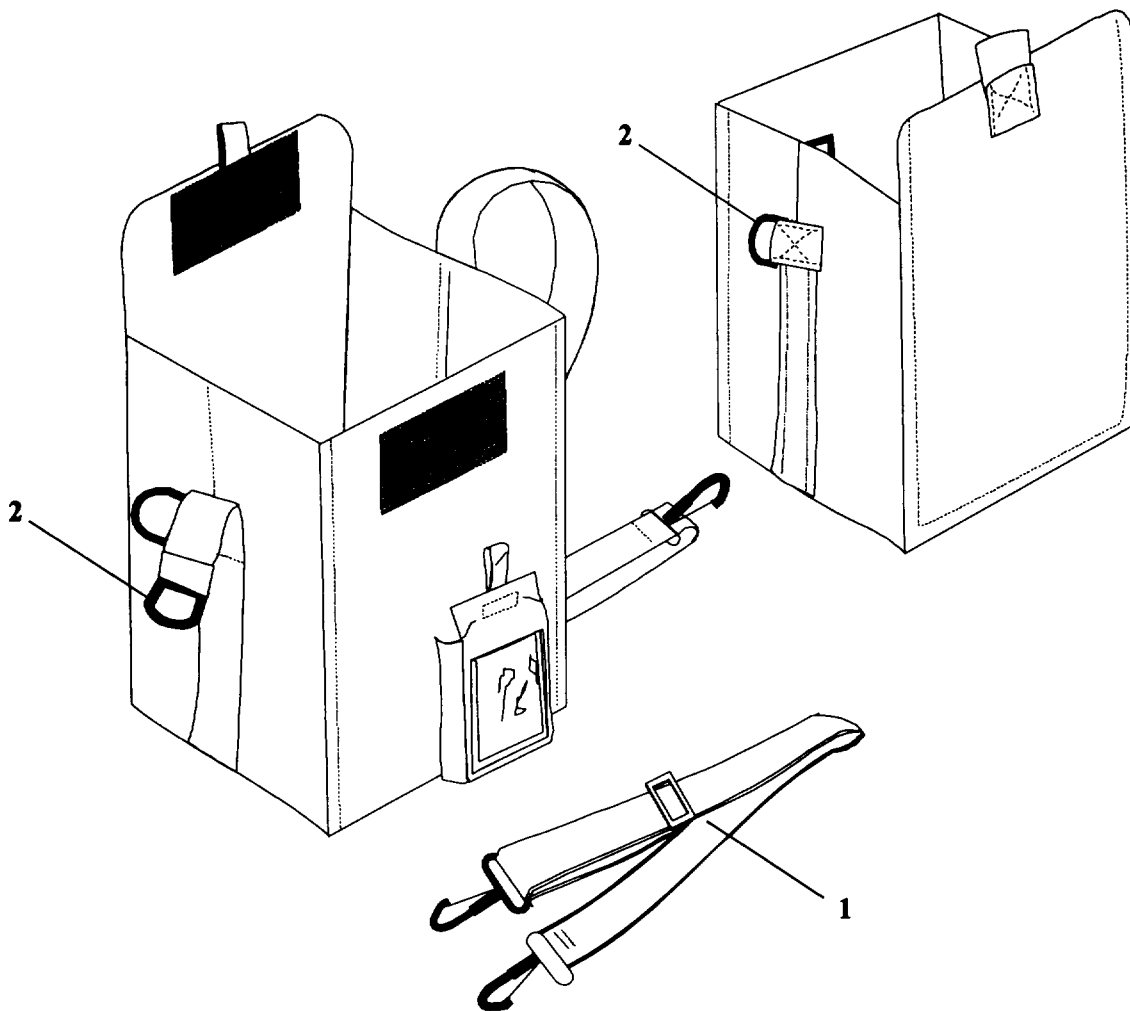

2-16. BLOWER ASSEMBLY REPAIR

This task covers:

- a. Control Knob Replacement
- b. Port Gaskets Replacement
- c. Strap Replacement
- d. Recess Caps Replacement
- e. Battery Cap Assembly Replacement

a. Control Knob Replacement.

INITIAL SETUP

Tools

None

Equipment Condition

Battery Removed

REMOVAL

NOTE

Use wrench that is supplied with new control knob for the following procedure.

1. Turn knob (1) counterclockwise to position zero.
2. Loosen exposed setscrew (2).
3. Turn knob clockwise to position three.
4. Loosen exposed setscrew (3).
5. Remove knob.

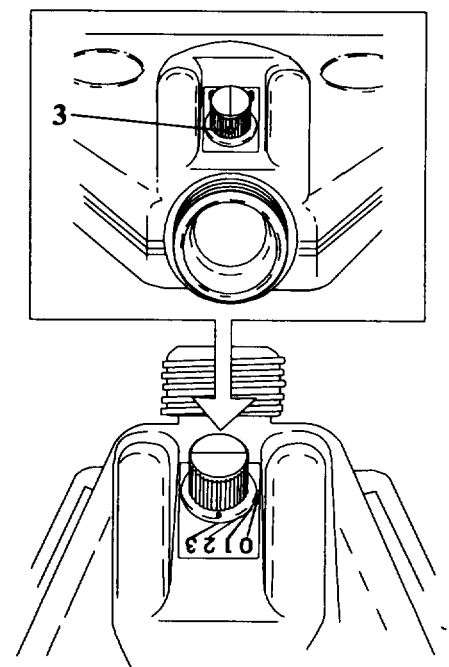
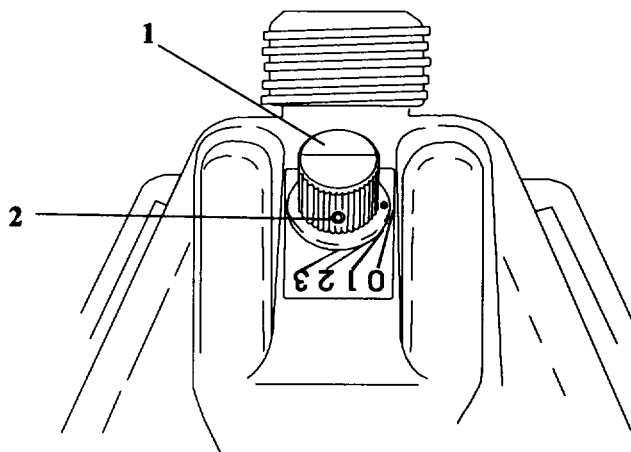

2-16. BLOWER ASSEMBLY REPAIR (CONT).**a. Control Knob Replacement (Cont).****INSTALLATION**

1. Place new knob (1) on shaft. Turn knob to position three.
2. Tighten exposed setscrews (3).
3. Turn knob counterclockwise to position zero.
4. Tighten exposed setscrew (2).

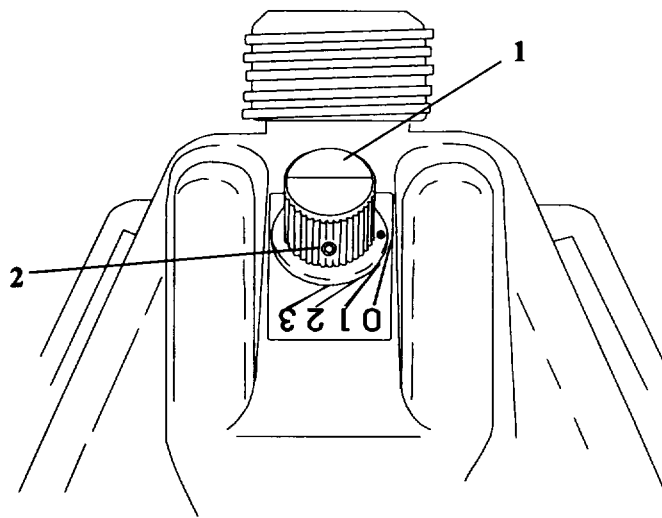
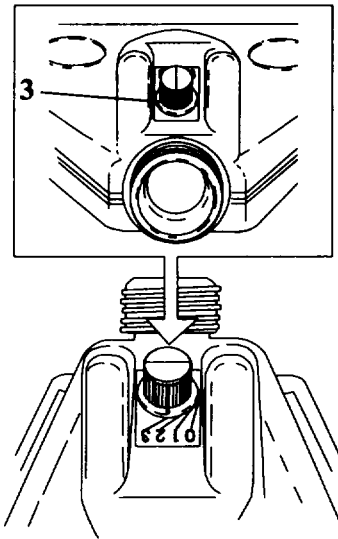

b. Port Gasket Replacement.

INITIAL SETUP**Tools**

None

Equipment Condition

Canisters Removed

Battery Removed

REMOVAL

Remove port gaskets (1) and discard.

INSTALLATION

1. Place gasket in port (2).

WARNING

Proper installation of gaskets is critical for proper function.

CAUTION

Do not use sharp implements to install gaskets. It may damage gaskets.

2. Work gasket into port until fully seated.

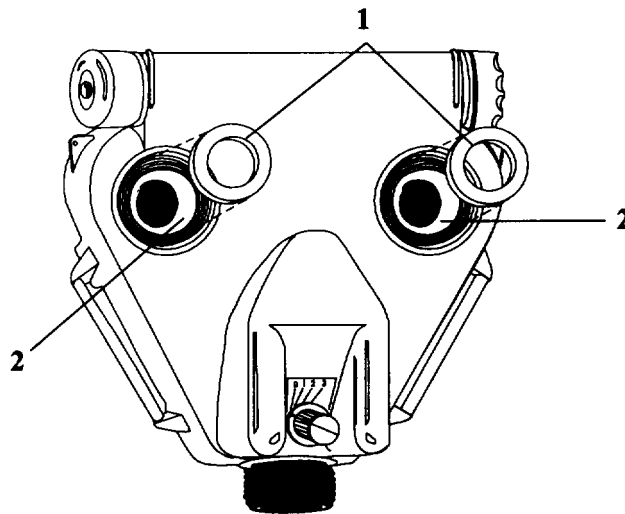

2-16 BLOWER ASSEMBLY REPAIR (CONT).

c. Strap Replacement

INITIAL SETUP

Tools

Tool Kit, Electronic Equipment TK 105G
(Item 1, App B, Sect. II)

REMOVAL

Remove screws (1) securing damaged strap.

INSTALLATION

1. Install new strap (2) with recessed side (3) of grommet facing out.

CAUTION

Do not over tighten screw, may damage blower.

2. Install screws.

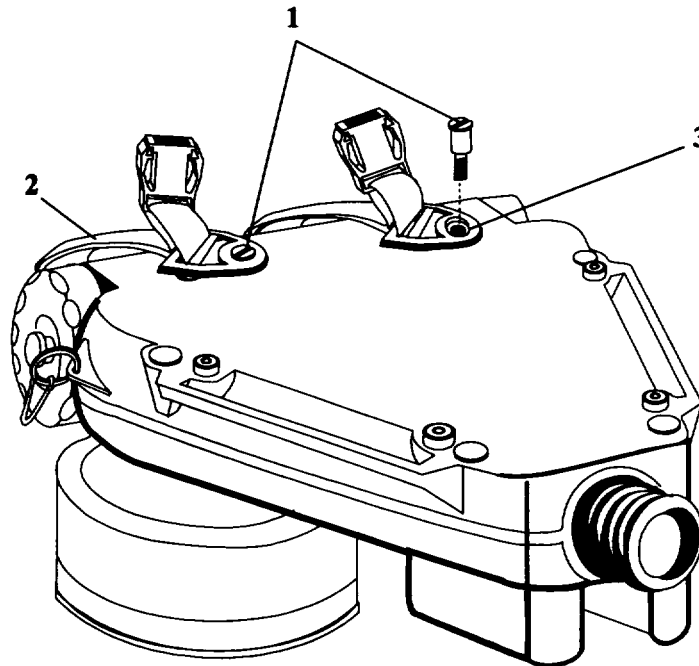

d. Recess Caps Replacement.

INITIAL SETUP

Tools

None

REMOVAL

Pry caps (1) from blower (2).

INSTALLATION

Insert cap into blower.

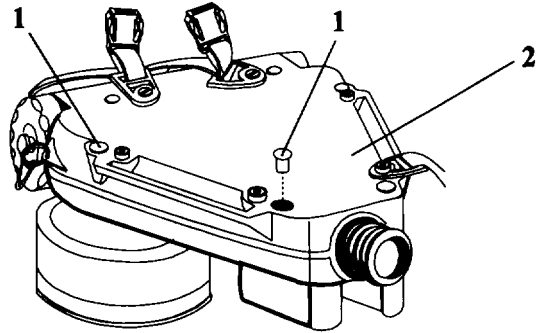

e. Battery Cap Assembly Replacement.

INITIAL SETUP

Tools

None

REMOVAL

1. Unscrew cap (1) from battery compartment (2).
2. Remove split ring (3) from blower housing.

INSTALLATION

1. Slide split ring onto blower housing.
2. Screw cap onto battery compartment.

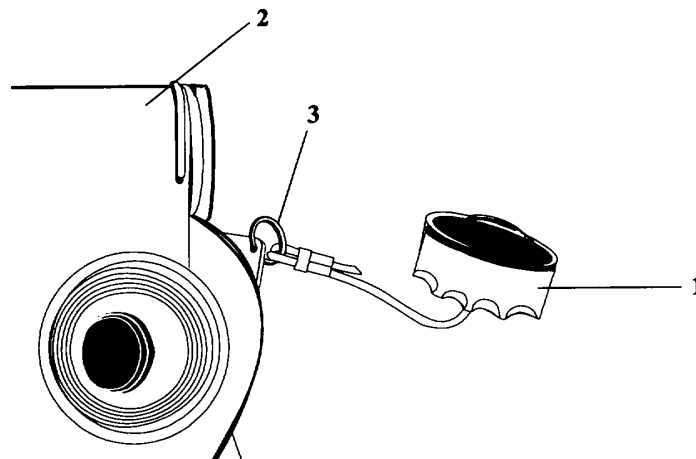

Section VII. PREPARATION FOR STORAGE AND SHIPMENT**2-17. GENERAL.**

This section contains storage and shipping information for the M48 Mask. The storage information is divided into two areas: Temporary Storage less than 30 days or Extended Storage 30 days or more.

2-18. PREPARATION FOR STORAGE OR SHIPMENT.**CAUTION**

Store mask in a dry place. Moisture may damage the mask components.

NOTE

Anytime the mask is stored for over 30 days, insert the faceform into the facepiece to prevent distortion of the faceblank.

a. Temporary Storage Less Than 30 Days.

- (1) Store faceform according to unit SOP.
- (2) Stow mask and accessories in carrier as described in Operator's Manual, TM 3-4240-342-10.
- (3) Hang the carrier by the shoulder strap.
- (4) Make sure storage temperatures remain between -25°F and +125°F (-31.7°C and +51.70°C).

b. Extended Storage (30 Days or More).

- (1) Remove batteries from blower and store separately.
- (2) Insert faceform into facepiece to prevent distortion.
- (3) Stow mask and accessories in original foam in shipping carton.
- (4) Make sure storage temperatures remain between -60°F and +160°F (-51.1°C and 71.1°C).

2-18. PREPARATION FOR STORAGE OR SHIPMENT (CONT).

c. Shipment.

WARNING

Lithium-sulfur dioxide (LiSO_2) batteries which are used in this equipment contain pressurized sulfur dioxide (SO_2) gas. The gas is toxic, and the battery **MUST NOT** be abused in any way which may cause the battery to rupture.

A hissing sound from the battery or the smell of vinegar or rotten eggs indicates a leaking battery. If a leaking battery is detected, move battery to well-ventilated storage area and contact Defense Reutilization and Marketing Office (DRMO) for disposal.

LITHIUM-SULFUR DIOXIDE BATTERIES. Do not attempt to decontaminate batteries. Dispose of batteries according to TB 43-0130 and local SOP.

Remove batteries from blower. Use box, lid, and internal packaging retained in Service Upon Receipt of Material, para 2-5.

Section VIII. MASK SERVICING**2-19. GENERAL.**

This section contains cleaning/sanitizing procedures for the facepiece and blower assembly. This section also contains decontaminating procedures for the blower assembly, facepiece and nuclear hood. For decontamination of other components of the M48 Mask, follow procedures in FM 3-5.

2-20. CLEANING.

Refer to TM 3-4240-342-10, para 3-6.

2-21. SANITIZING FACEPIECE.**WARNING**

Protect hands from prolonged exposure to alcohol by wearing gloves.

NOTE

Cleaning should be done prior to sanitizing. Refer to TM 34240-342-10, para 3-6. Sanitizing is required before mask is transferred to another soldier and when the mask is turned in as serviceable. Sanitizing may be performed by the operator but must be closely supervised and inspected by the ALSE technician.

1. Remove outlet valve disk and discard.
2. Remove microphone and air deflector. Wipe with clean cheesecloth and isopropyl alcohol and set aside.
3. Remove M1 canteen cap and empty canteen. Pour approximately 4 ounces of alcohol into clean canteen and reinstall cap.
4. Fold hood over front of facepiece.
5. With facepiece outside up, connect the external drink tube to the canteen cap.
6. Hold facepiece outside up so that alcohol can drain through external drink tube.
7. While inverting canteen above facepiece, squeeze canteen until alcohol begins to flow from internal drink tube.
8. Without releasing canteen, disconnect the quick disconnect from canteen.
9. Wait 60 seconds.

2-21. SANITIZING FACEPIECE (CONT).

10. Reattach canteen and flush with remaining alcohol in canteen.
11. Rinse twice with two canteens full of clear water.
12. Connect empty canteen to quick disconnect and squeeze canteen to drain excess water.

2-22. DELIBERATE DECONTAMINATION OPERATION.**a. Decontaminate Blower Assembly.****WARNING**

Use caution when performing the following step. Excess liquid agent may be on the threaded part of the blower and / or the mating threads on the swivel assembly.

- (1) Detach blower from hose by unscrewing swivel counterclockwise.
- (2) Using clean and dry cheesecloth, wipe threaded area of swivel assembly and mating threads on the blower.
- (3) Remove straps (para 2-16c) from blower and discard. Reinstall screws into blower.
- (4) Remove armband from blower and discard.
- (5) Using clean and dry cheesecloth dipped in hot soapy water (use soap in accordance with FM 3-5), wring almost dry and wipe blower surface.
- (6) Using clean and dry cheesecloth dipped in potable water and wrung almost dry, wipe blower surface.
- (7) Dip clean and dry cheesecloth into mask sanitizing solution (FM 3-5), wring almost dry and wipe blower surface.

WARNING

To perform the following procedure (steps 7-12) keep canister ports facing downward. If contaminants enter blower, it may cause injury to personnel and/or damage to equipment.

- (8) While holding blower with canisters facing downward, unscrew canisters and discard.
- (9) Dip clean and dry cheesecloth into mask sanitizing solution (FM 3-5), wring almost dry and wipe canister ports.

- (10) Remove gaskets from canister ports and discard.
- (11) Dip clean and dry cheesecloth into mask sanitizing solution, wring almost dry, wipe blower surface including canister ports and outlet port.
- (12) Using clean and dry cheesecloth dipped in potable water, wrung almost dry, wipe blower surface including canister ports and outlet port.
- (13) Turn blower on low setting and allow to air dry for 30 minutes.
- (14) Turn blower off. Replace battery, gaskets, canisters, straps and armband on blower.

b. Decontaminate Facepiece.

- (1) Remove gasket from swivel and discard.
- (2) Remove microphone and microphone adapter from inside facepiece (para 2-15g).
- (3) Immerse facepiece in container with hot water 1940F to 2030F (90°C to 950C) and soap (item 17, App D) and keep covered for 30 minutes.

NOTE

Stir to prevent hoses from floating to the top.

- (4) Rinse facepiece thoroughly with potable water.
- (5) Dip facepiece in mask sanitizing solution in accordance with FM 3-5.
- (6) Rinse facepiece in potable water again.
- (7) Use clean and dry cheesecloth (item 7, App D) to wipe facepiece dry.
- (8) Reinstall microphone and microphone adapter (para 2-15g).
- (9) Replace gasket in swivel (para 2-15j).

APPENDIX A
REFERENCES

A-1. SCOPE.

This appendix lists all forms, field manuals, technical manuals and miscellaneous publications referenced in this manual.

A-2. FORMS.

Quality Deficiency Report	SF 368
Recommended Changes to Equipment Technical Publications.....	DA Form 2028-2
Recommended Changes to Publications and Blank Forms	DA Form 2028
Report of Discrepancy (ROD)	SF 364
Preventive Maintenance Schedule and Records.....	DD Form 314
Equipment Inspection and Maintenance Worksheet.....	DA Form 2404

A-3. FIELD MANUALS.

First Aid for Soldiers	FM 21-11
NBC Protection.....	FM 3-4
NBC Decontamination	FM 3-5

A-4. TECHNICAL MANUALS

Destruction of Chemical Weapons and Defense Equipment to Prevent Enemy Use.....	TM43-0002-31
Aircrew Survival Armor Recovery Vest, Insert, and Packets (SARVIP)	TM55-1680-317-23&P
The Army Maintenance Management System (TAMMS).....	DA PAM 738-750

A-5. MISCELLANEOUS PUBLICATIONS.

Ophthalmic ServicesAR 40-63

Research, Development, Test and Evaluation of Materiel for Extreme Climatic Conditions.....AR 70-38

Issue and Sale of Personal ClothingAR 700-84

Chemical-Biological Canisters and Filter Elements: Serviceability Lists.....SB 3-30-2

Army Medical Department Expendable and Durable ItemsCTA 8-100

Expendable Items (Except Medical, Class V, Repair Parts, and Heraldic Items)CTA 50-970

Respiratory Protection ProgramTB MED 502

Instructions for the Safe Handling and Identification of U.S. Army Communications-Electronics Command Managed Lithium-Sulfur Dioxide BatteriesTB 43-0130

APPENDIX B

MAINTENANCE ALLOCATION CHART

Section I. INTRODUCTION

B-1. THE ARMY MAINTENANCE SYSTEM MAC.

a. This introduction (Section I) provides a general explanation of all maintenance and repair functions authorized at various maintenance levels under the standard Army Maintenance System concept.

b. The Maintenance Allocation Chart (MAC) in Section II designates overall authority and responsibility for the performance of maintenance functions on the identified end item or component. The application of the maintenance functions to the end item or component will be consistent with the capacities and capabilities of the designated maintenance levels which are shown on the MAC in column (4) as:

Unit includes two subcolumns, C (operator/crew) and 0 (unit) maintenance.

Direct Support includes an F subcolumn.

General Support includes an H subcolumn.

Depot includes a D subcolumn.

c. Section m lists the tools and test equipment (both special tools and common tool sets) required for each maintenance function as referenced from Section II.

d. Section IV contains supplemental instructions and explanatory notes for a particular maintenance function.

B-2. MAINTENANCE FUNCTIONS.

Maintenance functions will be limited to and defined as follows:

a. Inspect. To determine the serviceability of an item by comparing its physical, mechanical, and/or electrical characteristics with established standards through examination (e.g., by sight, sound, or feel).

b. Test. To verify serviceability by measuring the mechanical, pneumatic, hydraulic, or electrical characteristics of an item and comparing those characteristics with prescribed standards.

c. Service. Operations required periodically to keep an item in proper operating condition, i.e., to clean (includes decontaminate, when required), to preserve, to drain, to paint, or to replenish fuel, lubricants, chemical fluids or gases.

d. Adjust. To maintain or regulate, within prescribed limits, by bringing into proper or exact position, or by setting the operating characteristics to specified parameters.

e. Align. To adjust specified variable elements of an item to bring about optimum or desired performance.

B-2. MAINTENANCE FUNCTIONS (CONT).

f. Calibrate. To determine and cause corrections to be made or to be adjusted on instruments or test, measuring, and diagnostic equipments used in precision measurement. Consists of comparisons of two instruments, one of which is a certified standard of known accuracy, to detect and adjust any discrepancy in the accuracy of the instrument being compared.

g. Remove/Install. To remove and install the same item when required to perform service or other maintenance functions. Install may be the act of emplacing, seating, or fixing into position a spare, repair part, or module (component or assembly) in a manner to allow the proper functioning of an equipment or system.

h. Replace. To remove an unserviceable item and install a serviceable counterpart in its place. "Replace" is authorized by the MAC and assigned maintenance level is shown as the 3rd position code of the SMR code.

i. Repair. The application of maintenance services including fault location/troubleshooting, removal/ installation, and disassembly/assembly procedures, and maintenance actions to identify troubles and restore serviceability to an item by correcting specific damage, fault, malfunction, or failure in a part, subassembly, module (component or assembly), end item, or system.

j. Overhaul. That maintenance effort (service/action) prescribed to restore an item to a completely serviceable/operational condition as required by maintenance standards in appropriate technical publications (i.e., DMWR). Overhaul is normally the highest degree of maintenance performed by the Army. Overhaul does not normally return an item to like new condition.

k. Rebuild. Consists of those services/actions necessary for the restoration of unserviceable equipment to a like new condition in accordance with original manufacturing standards. Rebuild is the highest degree of materiel maintenance applied to Army equipment. The rebuild operation includes the act of returning to zero those age measurements (hours/miles, etc.) considered in classifying Army equipment/components.

B-3. EXPLANATION OF COLUMNS IN THE MAC, SECTION II.

a. Column (1), Group Number. Column (1) lists functional group code numbers, the purpose of which is to identify maintenance significant components, assemblies, subassemblies, and modules with the next higher assembly.

b. Column (2), Component/Assembly. Column (2) contains the item names of components, assemblies, subassemblies, and modules for which maintenance is authorized.

c. Column (3), Maintenance Function. Column (3) lists the functions to be performed on the item listed in column (2).

d. Column (4), Maintenance Level. Column (4) specifies, each level of maintenance authorized to perform each function listed in column (3), by indicating work time required (expressed as man-hours in whole hours or decimals) in the appropriate subcolumn. This work-time figure represents the active time required to perform that maintenance function at the indicated level of maintenance. If the number or complexity of the tasks within the listed maintenance function vary at different levels, appropriate work time figures will be shown for each level. The work time figure represents the average time required to restore an item (assembly, subassembly, component, module, end item, or system) to a serviceable condition under typical field operating conditions. This time includes preparation time (including any necessary disassembly/assembly time), troubleshooting/fault location time, and quality assurance/quality control time in addition to the time required to perform the specific tasks identified for the maintenance functions authorized in the Maintenance Allocation Chart.

The symbol designations for the various maintenance levels are as follows:

- C Operator or Crew
- O..... Unit Maintenance
- F..... Direct Support
Maintenance
- H General Support
Maintenance
- L..... Specialized Repair
Activity (SRA)
- D Depot Maintenance

e. Column (5), Tools and Equipment. Column (5) specifies, by code, those common tool sets (not individual tools), and special tools, TMDE, and support equipment required to perform the designated function.

f. Column (6), Remarks. This column shall, when applicable, contain a letter code, in alphabetic order, which shall be keyed to the remarks contained in Section IV.

B4. EXPLANATION OF COLUMNS IN TOOL AND TEST EQUIPMENT REQUIREMENTS, SECTION II.

- a. Column (1), Reference Code.** The tool and test equipment reference code correlates with the code used in the MAC, Section II, Column 5.
- b. Column (2), Maintenance Level.** The lowest level of maintenance authorized to use the tool or test equipment.
- c. Column (3), Nomenclature.** Name or identification of the tool or test equipment.
- d. Column (4), National Stock Number.** The National stock number of the tool or test equipment.
- e. Column (5), Tool Number.** The manufacturer's part number.

B-5. EXPLANATION OF COLUMNS IN REMARKS, SECTION IV . Not Applicable.

**Section II. DRAFT MAINTENANCE ALLOCATION CHART
FOR
M48 MASK**

(1) Group Number	(2) Component/ Assembly	(3) Maint. Function	(4) Maintenance Level					(5) Tools and Equipment	(6) Remarks Code
			Unit		Direct Support	General Support	Depot		
			C	O	F	H	D		
00	Mask	Inspect Service Replace Repair Overhaul	0.2 0.5	0.6 0.1 0.1			8.0	1,2,3	
01	Mask Assembly	Inspect Service Repair	0.1 0.4	0.5 0.1			1		
0101	Facepiece Assembly	Inspect Test Adjust Replace Repair	0.2	0.2 0.2 0.4 0.1 0.2			0.2 0.9	1 1,3	
01010	Inlet Valve Assembly	Inspect Replace Repair	0.1	0.1 0.1			0.3 0.5	1 1	
01010101	Actuator Shaft Assembly	Replace Repair		0.2			0.3 0.3	1 1	
01010102	Actuator Shaft Assembly	Replace Repair		0.2			0.3 0.3	1 1	
0101021	Outlet Valve Assembly	Inspect Replace Repair	0.1 0.1				0.4 0.4	1 1	
01010201	Cover Valve Assembly	Replace Repair		0.2 0.2				1 1	
0101031	Communication Assembly	Inspect Repair	0.1	0.4				1,2	
0102	Mask Carrier	Inspect Replace Repair	0.1	0.1 0.1 0.2					
02	Blower Assembly	Inspect Test Service Repair	0.1 0.1 0.1	0.1 0.2 0.1			0.5	1	

Section III. TOOL AND TEST EQUIPMENT REQUIREMENT

Tool or Test Equipment Ref Code	Maintenance Level	Nomenclature	National/NATO Stock Number	Tool Number
1	O	Tool Kit, Electronic Equipment	5180-00-610-8177	TK 105G
2	O	Multimeter, Digital	6625-01-139-2512	TOO377
3	O	Maintenance Kit, Toxicological	8415-00-889-3654	MIL-M-41837

SECTION IV. REMARKS. Not Applicable.

B-5/(B-6 blank)

APPENDIX C
UNIT MAINTENANCE
REPAIR PARTS AND SPECIAL TOOLS LIST

Current as of 30 May 1997

SECTION I. INTRODUCTION

C-1. SCOPE.

This RPSTL lists and authorizes spares and repair parts; special tools; special test, measurement, and diagnostic equipment (TMDE), and other special support equipment required for performance of Unit maintenance of the M48 Mask. It authorizes the requisitioning, issue, and disposition of spares, repair parts and special tools as indicated by the source, maintenance and recoverability (SMR) codes.

C-2. GENERAL.

This Repair Parts and Special Tools List is divided into the following sections:

a. Section II. Repair Parts List. A list of spares and repair parts authorized by this RPSTL for use in the performance of maintenance. The list also includes parts which must be removed for replacement of the authorized parts. Parts lists are composed of functional groups in ascending alphanumeric sequence, with the parts in each group listed in ascending figure and item number sequence. Bulk materials are listed by item name in FIG. BULK at the end of the Section. Items listed are shown on the associated illustration.

b. Section III. Special Tools List . Not applicable.

c. Section IV. Cross-reference Index. A list, in National Item Identification Number (NIIN) sequence, of all National Stock Numbers (NSN) appearing in the listings, followed by a separate list in alphanumeric sequence of all part numbers appearing in the listings. National stock numbers and part numbers are cross-referenced to each illustration figure and item number appearance. The figure and item number index lists figure and item numbers in alphanumeric sequence and cross-references NSN, CAGEC and part numbers.

C-3. EXPLANATION OF COLUMNS (Sections II and III).

a. ITEM NO. (Column (1)). Indicates the number used to identify items called out in the illustration.

b. SMR CODE (Column (2)). The Source, Maintenance, and Recoverability (SMR) code is a 5-position code containing supply/requisitioning information, maintenance level authorization criteria, and disposition instruction, as shown in the following breakout:

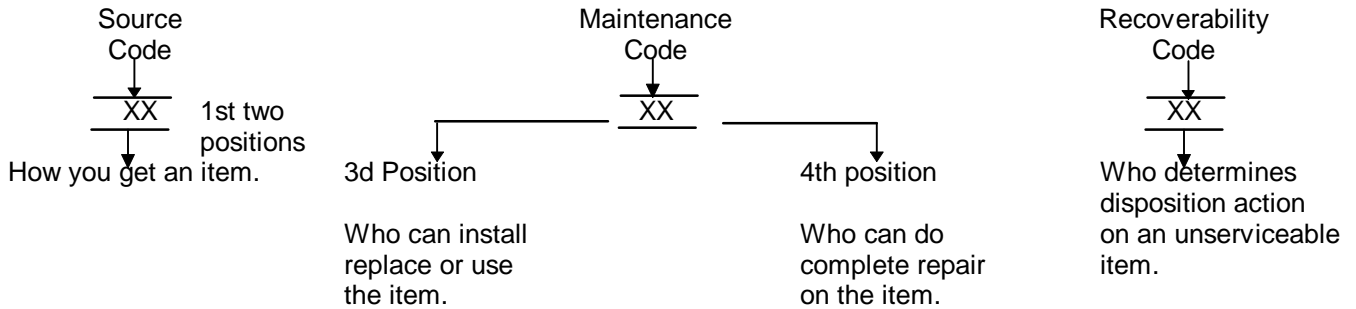

*Complete Repair: Maintenance capacity, capability and authority to perform all corrective maintenance tasks of the "Repair" function in a use/user environment in order to restore serviceability to a failed item.

(1) Source Code. The source code tells you how to get an item needed for maintenance, repair, or overhaul of an end item/equipment. Explanations of source codes follow:

Code	Explanation	
PA	Stocked items; use the applicable NSN to request/requisition items with these source codes. They are authorized to the level indicated by the code entered in the 3d position of the SMR code.	
PB		
PC**		
PD		
PE		
PF		
PG		
KD		**NOTE: Items coded PC are subject to deterioration.
KF		
KB		
MO-(Made at unit Level)	Items with these codes are not to be requested/requisitioned individually. They must be made from bulk material which is identified by the part number in the DESCRIPTION AND USABLE ON CODE (UOC) column and listed in the bulk material group in the parts lists in this RPSTL. If the item is authorized to you by the 3d position code of the SMR code, but the source code indicates it is made at a higher level, order the item from the higher level of maintenance.	
MF-(Made at intermediates DS Level)		
MH-(Made at intermediates DS Level)		
ML-(Made at specialized Repair Act(SRA))		
MD-(Made at Depot)		

<p>AO-(Assembled by unit Level) AF-(Assembled by Intermediates DS Level AH-(Assembled by Intermediate DS Level AL-(Assembled by AD-(Assembled by Depot)</p>
--

Items with these codes are not to be requested/requisitioned individually. The parts that make up the assembled item must be requisitioned or fabricated and assembled at the level of maintenance indicated by the source code. If the 3d position code of the SMR code authorizes you to replace the item, but the source code indicates the item is assembled at a higher level, order the item from the higher level of maintenance.

- XA** - Do not requisition an "XA" -coded item. Order its next higher assembly. (ALSO, refer to the NOTE below).
- XB** - If an "XB" item is not available from salvage, order it using the CAGEC and part number given.
- XC** - Installation drawing, diagram, instruction sheet, field service drawing, that is identified by manufacturer's part number.
- XD** - Item is nit stocked. Order an "XD" -coded item through normal channels using the CAGEC and part number given, if no NSN is available.

NOTE: Cannibalization or controlled exchange, when authorized, may be used as a source of supply for items with the above source codes, except for those source coded "XA" or those aircraft support items restricted by requirements of AR 750-1.

(2) Maintenance Code. Maintenance codes tell you the level(s) of maintenance authorized to USE and REPAIR support items. The maintenance codes are entered in the third and fourth positions of the SMR Code as follows:

(a) The maintenance code entered in the third position tells you the lowest maintenance level authorized to remove, replace, and use an item. The maintenance code entered in the third position will indicate authorization to one of the following levels of maintenance.

<u>Code</u>	<u>Application/Explanation</u>
C	-Crew or operator maintenance done within Unit or Aviation Unit maintenance.
0	-Unit or Aviation Unit level can remove, replace, and use the item.
F	-Direct support or Aviation Intermediate level can remove, replace, and use the item.
H	-General support level can remove, replace, and use the item.
L	-Specialized repair activity can remove, replace, and use the item.
D	-Depot level can remove, replace, and use the item.

C-3. EXPLANATION OF COLUMNS (Sections II and III) (CONT).

(b) The maintenance code entered in the fourth position tells whether or not the item is to be repaired and identifies the lowest maintenance level with the capability to do complete repair (i.e., perform all authorized repair functions). (NOTE: Some limited repair may be done on the item at a lower level of maintenance, if authorized by the Maintenance Allocation Chart (MAC) and SMR codes). This position will contain one of the following maintenance codes.

<u>Code</u>	<u>Application/Explanation</u>
O	- Unit or Aviation Unit is the lowest level that can do complete repair of the item.
F	- Direct support or Aviation Intermediate is the lowest level that can do complete repair of the item.
H	- General support is the lowest level that can do complete repair of the item.
L	- Specialized repair activity (designate the specialized repair activity) is the lowest level that can do complete repair of the item.
D	- Depot is the lowest level that can do complete repair of the item.
Z	- Nonreparable. No repair is authorized.
B	- No repair is authorized. (No parts or special tools are authorized for the maintenance of a "B" coded item). However, the item may be reconditioned by adjusting, lubricating, etc., at the user level.

(3) Recoverability Code. Recoverability codes are assigned to items to indicate the disposition action on unserviceable items. The recoverability code is entered in the fifth position of the SMR Code as follows:

<u>Recoverability</u>	<u>Codes Application/Explanation</u>
Z	- Nonreparable item. When unserviceable, condemn and dispose of the item at the level of maintenance shown in 3d position of SMR Code.
O	- Repairable item. When uneconomically repairable, condemn and dispose of the item at Unit or Aviation Unit level.
F	- Repairable item. When uneconomically repairable, condemn and dispose of the item at the Direct support or Aviation Intermediate level.
H	- Repairable item. When uneconomically repairable, condemn and dispose of the item at the General support level.
D	- Repairable item. When beyond lower level repair capability, return to depot. Condemnation and disposal of item not authorized below Depot level.
L	- Repairable item. Condemnation and disposal not authorized below Specialized Repair Activity (SRA).
A	- Item requires special handling or condemnation procedures because of specific reasons (e.g., precious metal content, high dollar value, critical material, or hazardous materiel). Refer to appropriate manuals/directives for specific instructions.

c. CAGEC (Column (3)). The Commercial and Government Entity Code (CAGEC) is a 5-digit code which is used to identify the manufacturer, distributor, or Government agency, etc., that supplies the item.

d. PART NUMBER (Column (4)). Indicates the primary number used by the manufacturer (individual, company, firm, corporation, or Government activity), which controls the design and characteristics of the item by means of its engineering drawings, specifications standards, and inspection requirements to identify an item or range of items.

NOTE: When you use an NSN to requisition an item, the item you receive may have a different part number from the part ordered.

e. DESCRIPTION AND USABLE ON CODE (UOC) (Column (5)). This column includes the following information:

(1) The Federal item name and, when required, a minimum description to identify the item.

(2) The usable on code, when applicable. See para C-5, Special Information.

(3) The statement "END OF FIGURE" appears just below the last item description in Column 5 for a given figure in both Section II and Section III.

f. QTY (Column (6)). The QTY (quantity per figure column) indicates the quantity of the item used in the breakout shown on the illustration figure, which is prepared for a functional group, subfunction group, or an assembly. A "V" appearing in this column in lieu of a quantity indicates that the quantity is variable and the quantity may vary from application to application.

C-4. EXPLANATION OF COLUMNS (Section IV).

a. NATIONAL STOCK NUMBER (NSN) INDEX

(1) STOCK NUMBER column. This column lists the NSN by National Item Identification Number (NIIN) sequence. The NIIN consists of the last nine digits of the NSN (i.e. $\frac{\text{NSN}}{5305-01-674-1467}$).

When using this column to locate an item, ignore the first 4 digits of the NSN. However, the complete NSN should be used when ordering items by stock number.

(2) FIG. column. This column lists the number of the figure where the item is identified/located. The figures are in numerical order in Section II and III.

(3) ITEM column. The item number identifies the item associated with the figure listed in the adjacent FIG. column. This item is also identified by the NSN listed on the same line.

C4. EXPLANATION OF COLUMNS (Section IV) (CONT).

b. PART NUMBER INDEX. Part numbers in this index are listed by part number in ascending alphanumeric sequence (i.e., vertical arrangement of letter and number combination which places the first letter or digit of each group in order A through Z, followed by the numbers 0 through 9 and each following letter or digit in like order).

(1) CAGEC column. The Commercial and Government Entity Code (CAGEC) is a 5-digit code used to identify the manufacturer, distributor, or Government agency, etc., that supplies the item.

(2) PART NUMBER column. Indicates the primary number used by the manufacturer (individual, firm, corporation, or Government activity), which controls the design and characteristics of the item by means of its engineering drawings, specifications standards, and inspection requirements to identify an item or range of items.

(3) STOCK NUMBER column. This column lists the NSN for the associated part number and manufacturer identified in the PART NUMBER and CAGEC columns to the left.

(4) FIG. column. This column lists the number of the figure where the item is identified/located in Section II and III.

(5) ITEM column. The item number is that number assigned to the item as it appears in the figure referenced in the adjacent figure number column.

c. FIGURE AND ITEM NUMBER INDEX.

(1) FIG. column. This column lists the number of the figure where the item is identified/located in Section II and III.

(2) ITEM column. The item number is that number assigned to the item as it appears in the figure referenced in the adjacent figure number column.

(3) STOCK NUMBER column. This column lists the NSN for the item.

(4) CAGEC column. The Commercial and Government Entity Code (CAGEC) is a 5-digit code used to identify the manufacturer, distributor, or Government agency, etc., that supplies the item.

(5) PART NUMBER column. Indicates the primary number used by the manufacturer (individual, firm, corporation, or Government activity), which controls the design and characteristics of the item by means of its engineering drawings, specification standards, and inspection requirements to identify an item or range of items.

C-5. SPECIAL INFORMATION.

a. **USABLE ON CODE.** The usable on code appears in the lower left corner of the Description Column heading. Usable on codes are shown as "UOC:....." in the Description Column (justified left) on the first line of the applicable item description/nomenclature. Uncoded items are applicable to all models. Identification of the usable on codes used in the RPSTL are:

Code	Used On
16S	M48 Apache Aviator Mask (Sm)
16M	M48 Apache Aviator Mask (Med)
16L	M48 Apache Aviator Mask (Lg)
16X	M48 Apache Aviator Mask (X-Lg)

C-6. HOW TO LOCATE REPAIR PARTS.

a. When National Stock Number or Part Number is Not Known.

(1) First. Using the table of contents, determine the functional group or subfunctional group to which the item belongs. This is necessary since figures are prepared for functional groups and subfunctional groups, and listings are divided into the same groups.

(2) Second. Find the figure covering the functional group or subfunctional group to which the item belongs.

(3) Third. Identify the item on the figure and use the Figure and Item Number Index to find the NSN.

b. When National Stock Number or Part Number is Known.

(1) First. Using the National Stock Number or the Part Number Index, find the pertinent National Stock Number or Part Number. The NSN index is in National Item Identification Number (NIIN) sequence (see C-4.a (1)). The part numbers in the Part Number Index are listed in ascending alphanumeric sequence (see C- 4.b). Both indexes cross-reference you to the illustration/figure and item number of the item you are looking for.

(2) Second. Turn to the figure and item number, verify that the item is the one you're looking for, then locate the item number in the repair parts list for the figure.

C-7. ABBREVIATIONS. Not applicable.

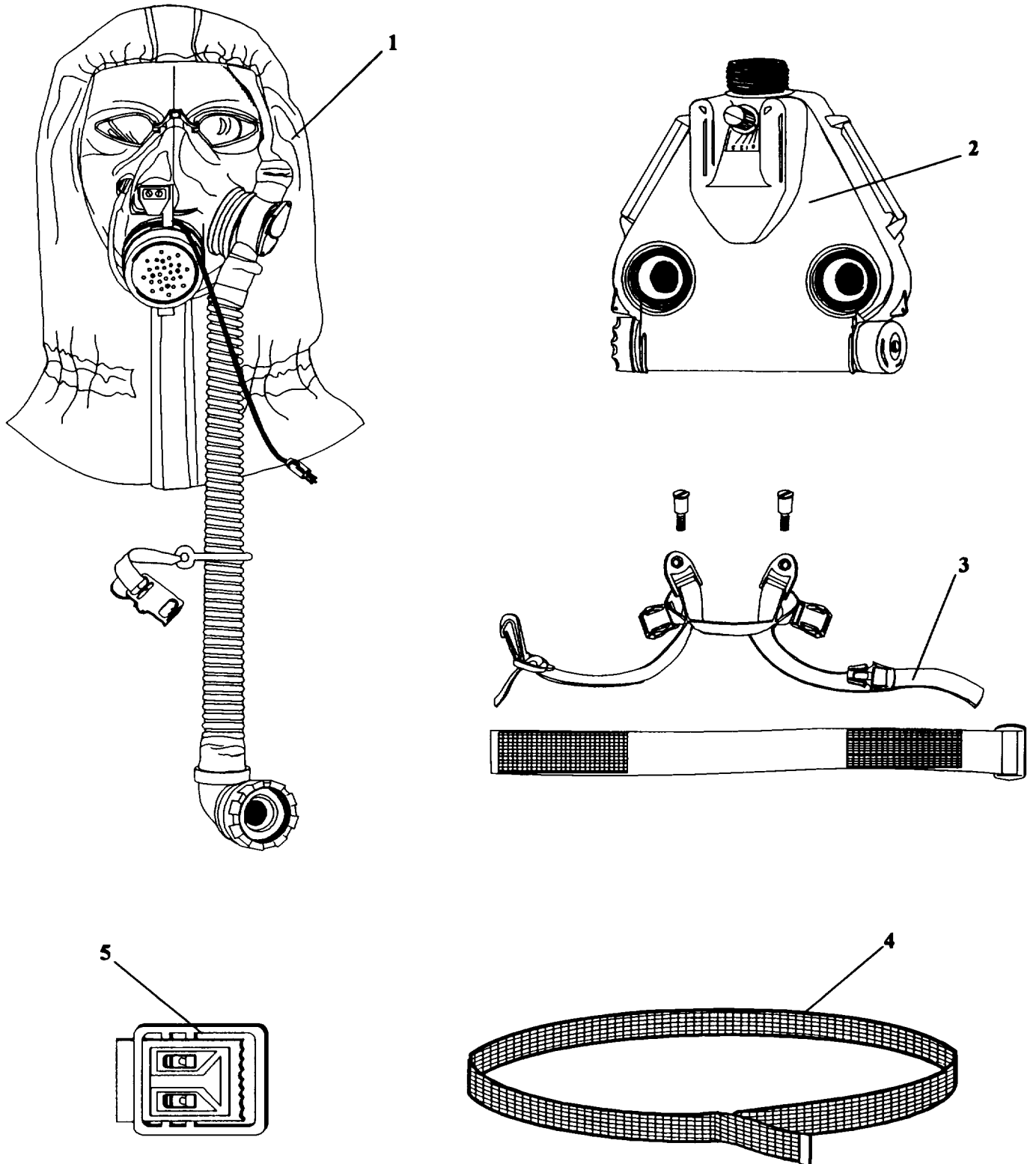

Figure C-1. Mask, Chemical-Biological Aircraft, Apache Aviator, M48

(1) ITEM NO	(2) SMR CODE	(3) CAGEC	(4) PART NUMBER	(5) DESCRIPTION AND USABLE ON CODES(UOC)	(6) QTY
				GROUP 00 MASK, CHEMICAL-BIOLOGICAL; AIRCRAFT APACHE AVIATOR, M48 5-1-3327-10/ 20/30/40	
				FIG. C-1	
1	XAODA	81361	5-1-3301-10	MASKASSEMBLY1 UOC: 16S	
1	XAODA	81361	5-1-3301-20	MASK ASSEMBLY1 UOC: 16M	
1	XAODA	81361	5-1-3301-30	MASK ASSEMBLY1 UOC: 16L	
1	XAODA	81361	5-1-3301-40	MASK ASSEMBLY1 UOC: 16X	
2	02HY7	81361	5-1-2789	BLOWER, LIGHTWEIGHT1	
3	PAOZZ	81361	5-1-2849	STRAP ASSY, BLOWER.....1	
4	PAOZZ	81349	MIL-B-833	BELT, TROUSERS.....1	
5	PAOZZ	81349	MIL-B-1963	BUCKLE, BELT1	

END OF FIGURE

C-1-1

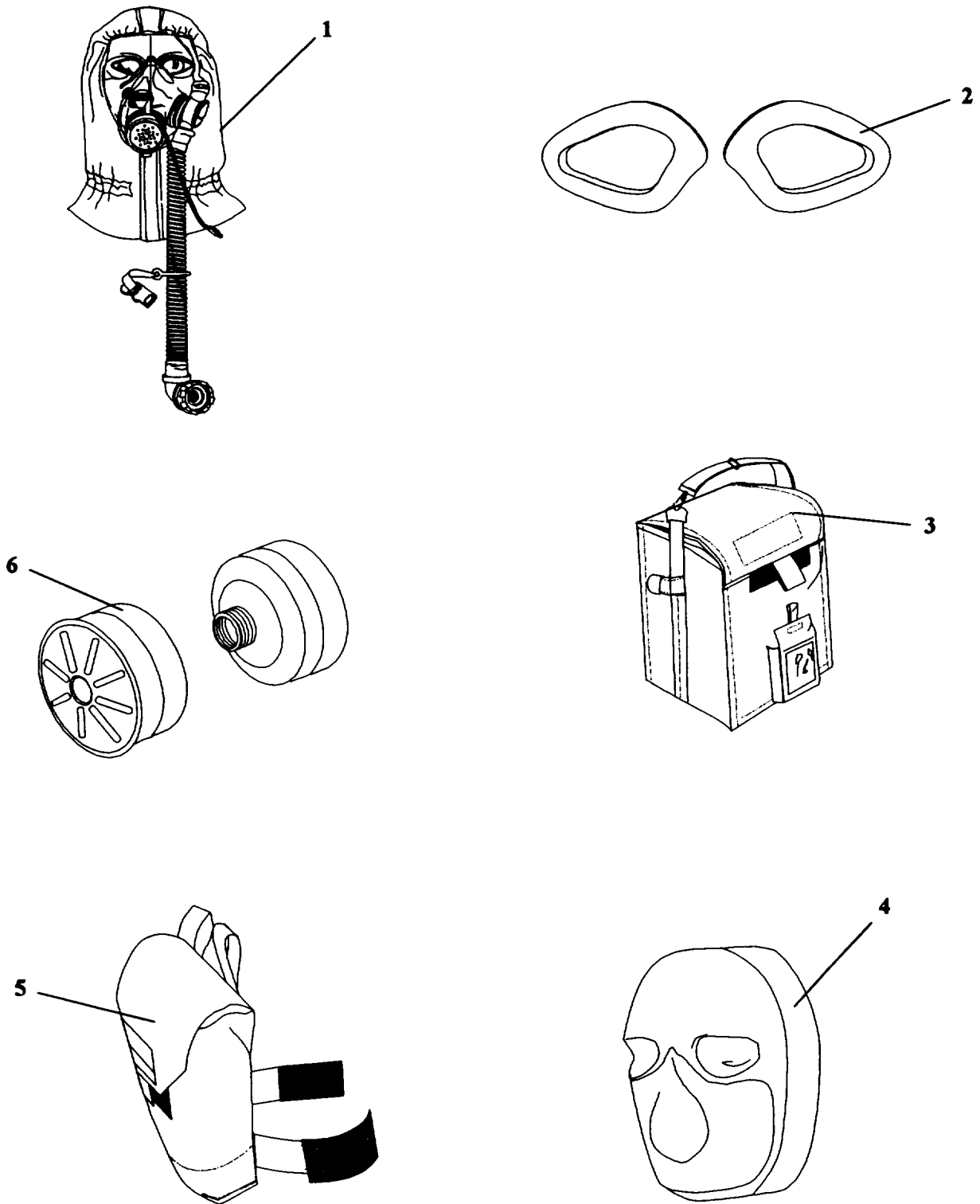

Figure C-2. Mask Assembly

(1) ITEM NO	(2) SMR CODE	(3) CAGEC	(4) PART NUMBER	(5) DESCRIPTION AND USABLE ON CODES(UOC)	(6) QTY
				GROUP 01 MASK ASSEMBLY	
				5-1-3301-10/ 20/30/40	
				FIG. C-2	
1	PCODD	81361	5-1-3370-10	FACEPIECE, MASK UOC: 16S	1
1	PCODD	81361	5-1-3370-20	FACEPIECE, MASK UOC: 16M	1
1	PCODD	81361	5-1-3370-30	FACEPIECE, MASK UOC :16L	1
1	PCODD	81361	5-1-337040	FACEPIECE, MASK UOC:1 6X	1
2	PAOZZ	81361	5-1-1489	CUSHION EYELENS.....	2
3	PAOOO	81361	5-1-1305	CARRIER, MASK	1
4	PAOZZ	81361	5-1-1312-1	FACEFORM, SM.....	1
4	PAOZZ	81361	5-1-1312-2	FACEFORM, MED.....	1
4	PAOZZ	81361	5-1-1312-3	FACEFORM, LG	1
4	PAOZZ	81361	5-1-1312-4	FACEFORM, EX LG	1
5	PAOZZ	81361	5-1-2529	CARRIER, FACEPIECE A	1
6	PCOZA	81361	5-3-1520	CANSTER, CHEMICAL-B.....	2

END OF FIGURE

C-2-1

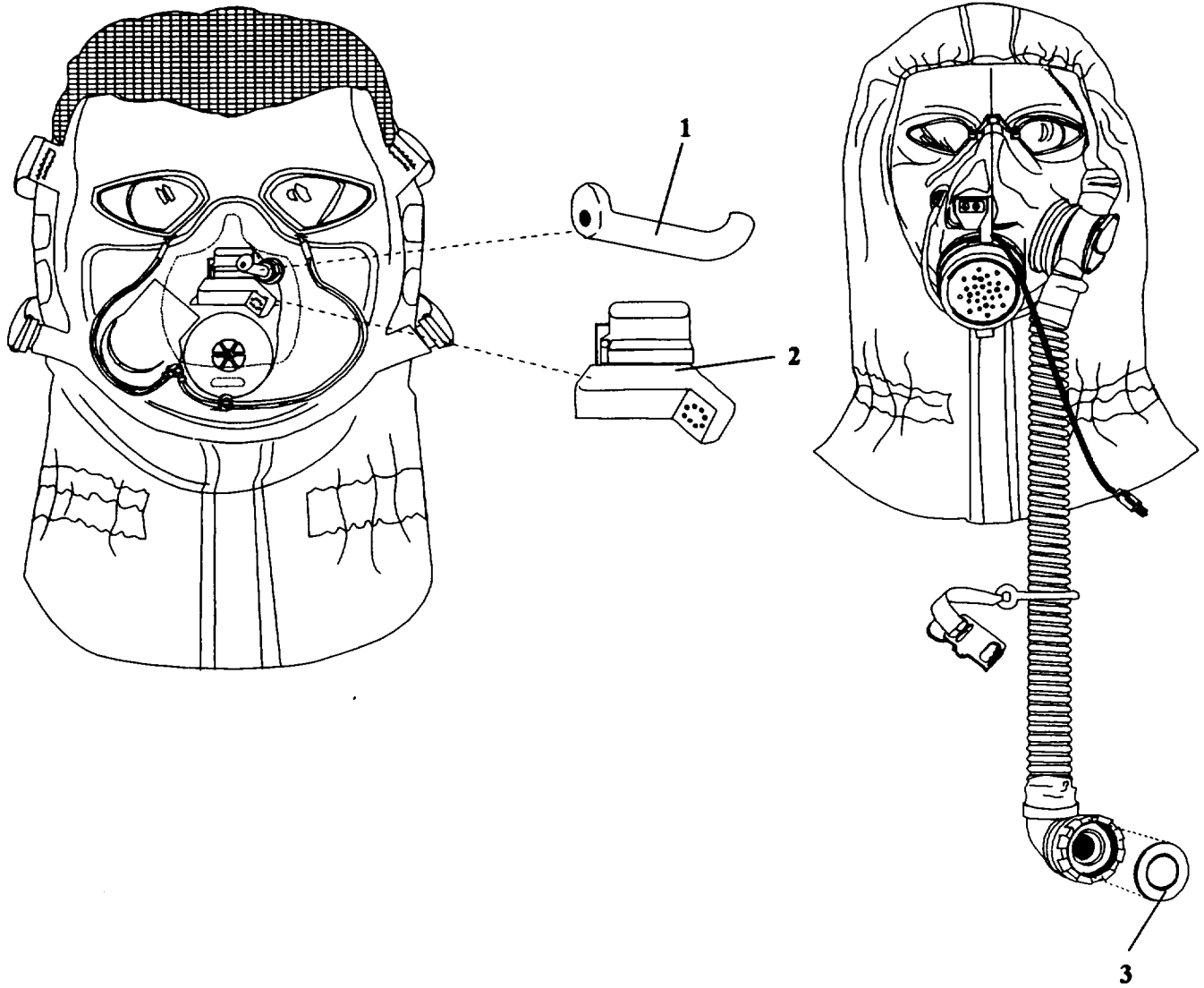

Figure C-3. Facepiece Assembly

(1)	(2)	(3)	(4)	(5)	(6)
ITEM NO	SMR CODE	CAGEC	PART NUMBER	DESCRIPTION AND USABLE ON CODES(UOC)	QTY

GROUP 0101
FACEPIECE ASSEMBLY

5-1-3370-10/20/30/40

FIG. C-3

1	PCOZZ	81361	51-1339	DRINK TUBE, INTERNAL.....	1
2	AOOOO	81361	5-1-2094-10	COMMUNICATION ASSY	1
3	PCOZZ	81361	5-1-1522	GASKET	1

END OF FIGURE

C-3-1

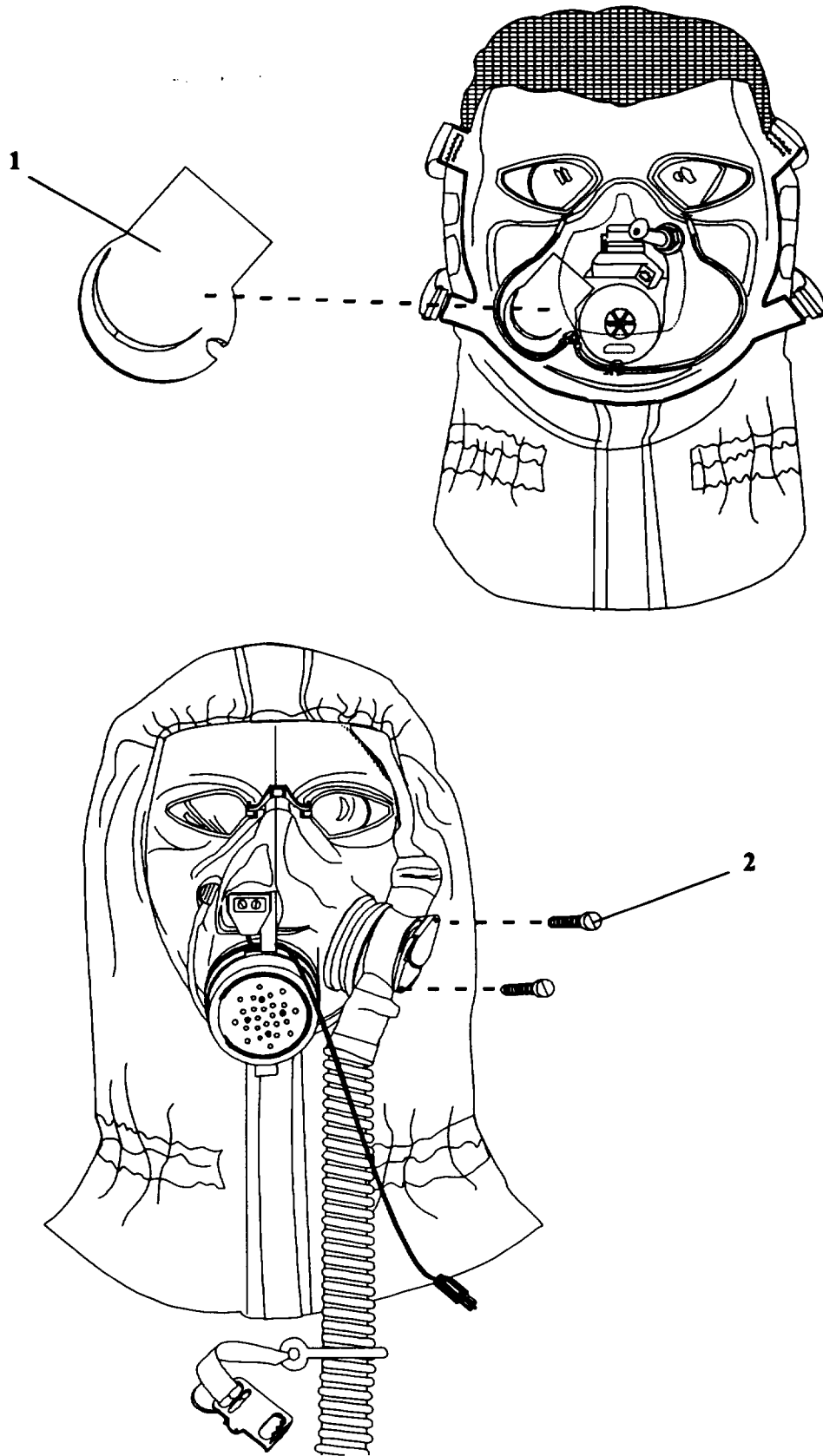

Figure C-4. Inlet Valve Assembly

(1)	(2)	(3)	(4)	(5)	(6)
ITEM NO	SMR CODE	CAGEC	PART NUMBER	DESCRIPTION AND USABLE ON CODES(UOC)	QTY

GROUP 010101
 INLET VALVE ASSEMBLY
 5-1-1410
 GROUP 01010101
 ACTUATOR SHAFTS ASSEMBLY
 5-1-1412

FIG. C-4

1	PAOZZ	81361	51-1443	DEFLECTOR, AIR.....	1
2	PAOZZ	81361	51-1762	SETSCREW.....	2

END OF FIGURE

C-4-1

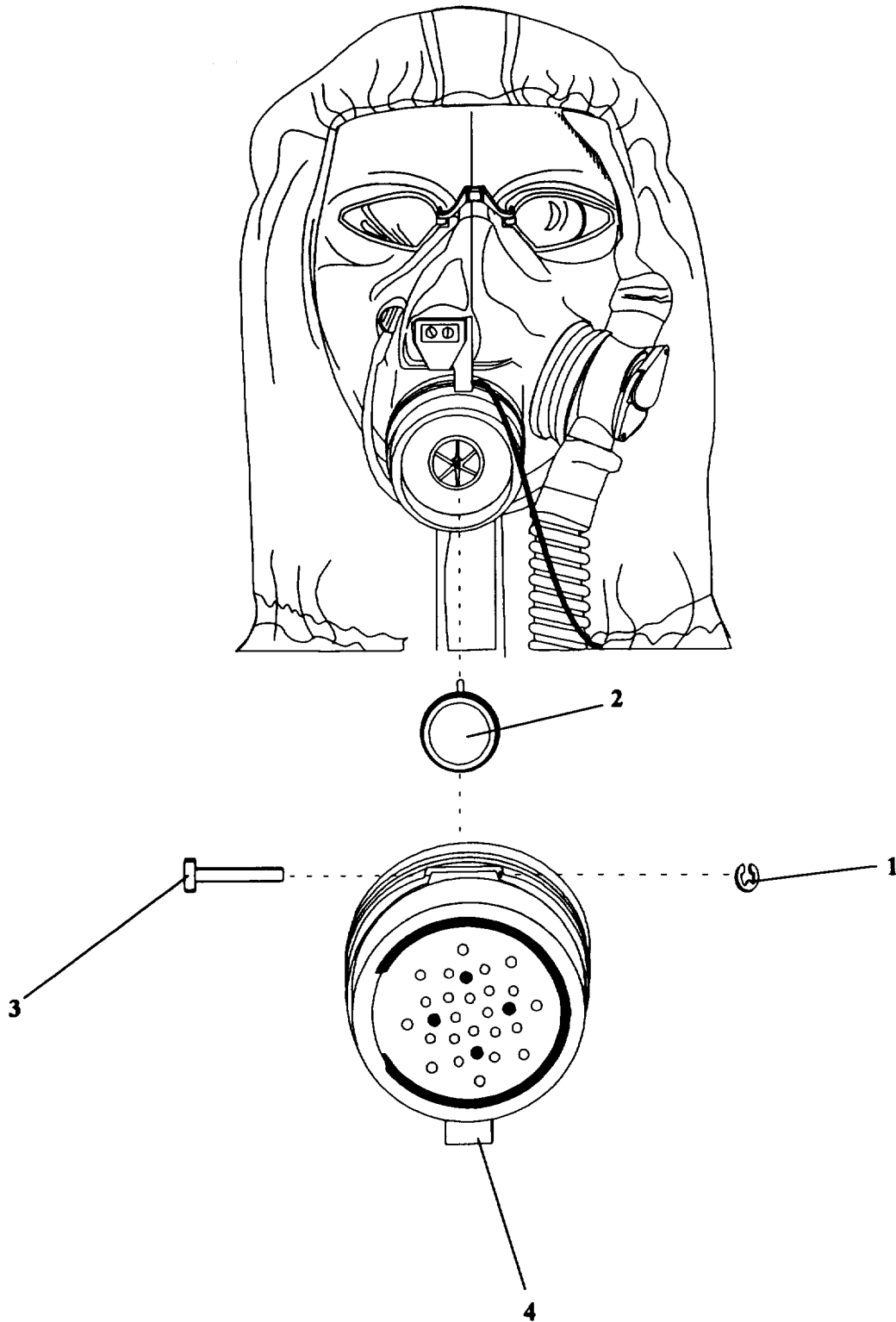

Figure C-5. Outlet Valve Assembly

(1)	(2)	(3)	(4)	(5)	(6)
ITEM NO	SMR CODE	CAGEC	PART NUMBER	DESCRIPTION AND USABLE ON CODES(UOC)	QTY

GROUP 010102
 OUTLET VALVE ASSEMBLY
 5-1-1414
 FIG. C-5

1	PAOZZ	96906	MS16633-4006	RING, RETAINING.....	1
2	PCOZZ	81361	51-1-057	DISK, VALVE	1
3	PAOZZ	81361	5-1-1370	PIN, GROOVED, HEADED.....	1
4	AOOOO	81361	5-1-1415	VALVE COVER ASSEMBLY.....	1

(SEE FIG. C-6 ASSEMBLY BKDN)

END OF FIGURE

C-5-1

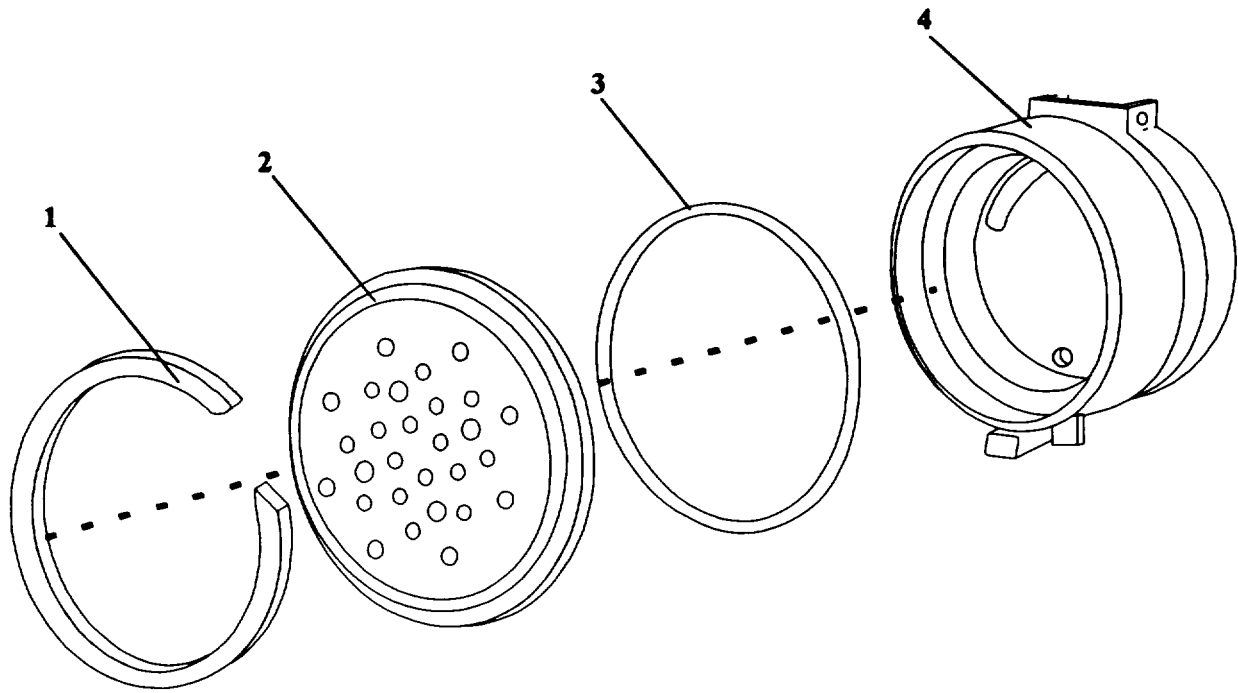

Figure C-6. Valve Cover Assembly

(1) ITEM NO	(2) SMR CODE	(3) CAGEC	(4) PART NUMBER	(5) DESCRIPTION AND USABLE ON CODES(UOC)	(6) QTY
				GROUP 01010201 VALVE COVER ASSEMBLY 5-1-1415	
				FIG. C-6	
1	KFOZZ	81361	5-1-1343	RING, RETAINING.....	1
2	KFOZZ	81361	5-1-1380	VOICEMITTER.....	1
3	KFOZZ	96906	MS9068-032	PACKING, PREFORMED.....	1
4	PAOZZ	81361	5-1-1455	COVER, OUTLET VALVE.....	1
KIT	PAOZZ	81361	5-1-1490	KIT, VOICEMITTER	1
				PACKING, PREFORMED (1) C6-3	
				RING, RETAINING (1) C-6-1	
				VOICEMITTER (1) C-6-2	

END OF FIGURE

C-6-1

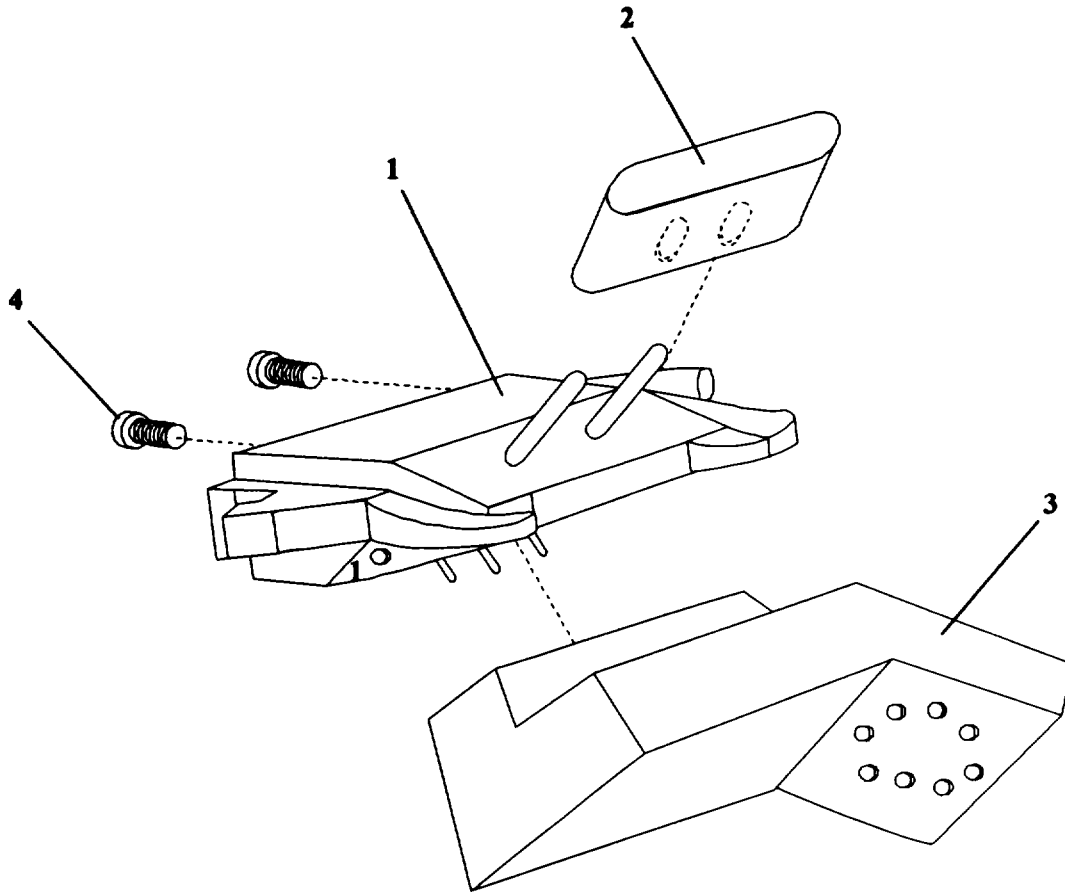

Figure C-7. Communications Assembly

(1)	(2)	(3)	(4)	(5)	(6)
ITEM NO	SMR CODE	CAGEC	PART NUMBER	DESCRIPTION AND USABLE ON CODES(UOC)	QTY

GROUP 010103
 COMMUNICATIONS ASSEMBLY
 5-1-2094-10

FIG. C-7

1	PAOZZ	81361	51-2095	ADAPTER, MICROPHONE.....	1
2	PAOZZ	81361	5-1-1436	PROTECTOR, PIN, MICRO.....	1
3	PAOZZ	59369	4500-CA	MICROPHONE, UNEAR.....	1
4	PAOZZ	80205	NAS1635-02LE4P	SCREW, SELF-LOCKING	1

END OF FIGURE

C-7-1

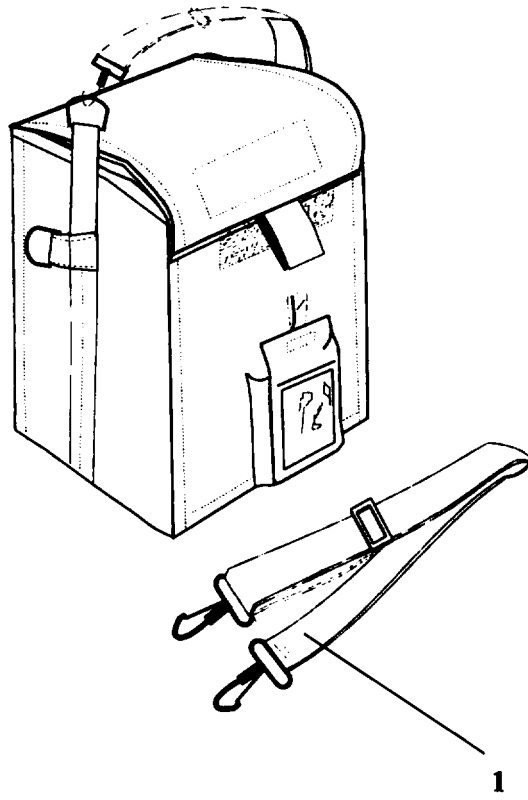

Figure C-8. Carrier, Mask

(1) ITEM NO	(2) SMR CODE	(3) CAGEC	(4) PART NUMBER	(5) DESCRIPTION AND USABLE ON CODES(UOC)	(6) QTY
-------------------	--------------------	--------------	-----------------------	---	------------

GROUP 0102
CARRIER MASK
5-1-1305

FIG. C-8

1	PAOZZ	81361	5-1-1303	STRAP, WEBBING	1
---	-------	-------	----------	----------------------	---

END OF FIGURE

C-8-1

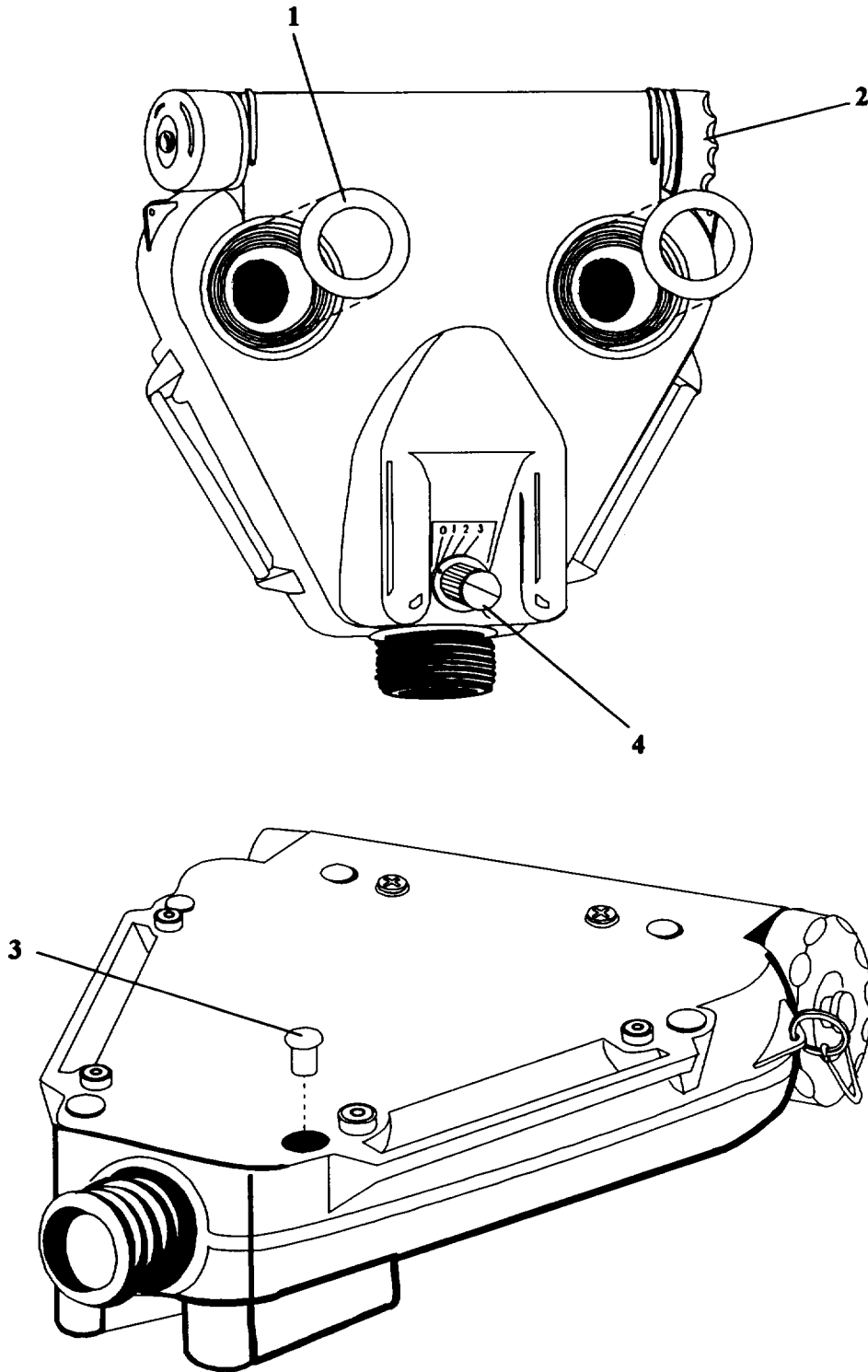

Figure C-9. Blower Assembly

(1)	(2)	(3)	(4)	(5)	(6)
ITEM NO	SMR CODE	CAGEC	PART NUMBER	DESCRIPTION AND USABLE ON CODES(UOC)	QTY

GROUP 02
 BLOWER ASSEMBLY
 51-2789

FIG. C-9

1	PCOZZ	81361	5-1-3384	GASKET	2
2	PAOZZ	81361	5-1-3383	BATTERY CAP.....	1
3	PAOZZ	81361	5-1-3385	CAPS, RECESS.....	7
4	PAOZZ	81361	5-1-3382	CONTROL KNOB.....	1

END OF FIGURE

C-9-1

Cross-Reference Indexes

National Stock Number Index

STOCK NUMBER	FIGURE NO.	ITEM NO.
8315-00-300-0327	C-1-1	5
5365-00-753-3868	C-5-1	1
5305-01-178-6225	C-7-1	4
8440-01-204-2610	C-1-1	4
4240-01-220-0548	C-4-1	1
4240-01-220-0550	C-6-1	KIT
4240-01-220-0552	C-3-1	1
4240-01-220-0553	C-2-1	1
4240-01-220-0560	C-2-1	3
4240-01-220-0664	C-8-1	1
4240-01-221-0392	C-6-1	4
4240-01-223-1395	C-2-1	5
4240-01-223-1396	C-2-1	5
4240-01-223-1397	C-2-1	S
4240-01-223-1398	C-2-1	5
5965-01-230-8792	C-7-1	2
5330-01-231-3877	C-3-1	3
5305-01-232-6728	C-4-1	2
5315-01-232-6790	C-5-1	3
5965-01-233-0355	C-7-1	3
4820-01-260-8709	C-5-1	2
4240-01-302-6742	C-2-1	6
4240-01-331-6153	C-2-1	4
5965-01-343-2543	C-7-1	1
4240-01-361-1319	C-2-1	6
4240-01-442-8415	C-1-1	2
5340-01-443-0246	C-1-1	3
4240-01-443-5478	C-2-1	1
4240-01-443-5479	C-2-1	1
4240-01-443-5480	C-2-1	1
4240-01-443-9350	C-2-1	1

C-I-1

Cross-Reference Indexes

Part Number Index

CAGEC	PART NUMBER	STOCK NUMBER	FIGURE	ITEM
81361	5-1-1057	4820-01-260-8709	C-5-1	2
81361	5-1-1303	5340-01-220-0664	C-8-1	1
81361	5-1-1305	4240-01-220-0560	C-2-1	3
81361	5-1-1312-1	4240-01-223-1395	C-2-1	5
81361	5-1-1312-2	4240-01-223-1396	C-2-1	5
81361	5-1-1312-3	4240-01-223-1397	C-2-1	5
81361	5-1-1312-4	4240-01-223-1398	C-2-1	5
81361	5-1-1339	4240-01-220-0552	C-3-1	1
81361	5-1-1343		C-6-1	1
81361	5-1-1370	5315-01-232-6790	C-5-1	3
81361	5-1-1380		C-6-1	2
81361	5-1-1415		C-5-1	4
81361	5-1-1436	5965-01-230-8792	C-7-1	2
81361	5-1-1443	4240-01-220-0548	C-4-1	1
81361	5-1-1455	4240-01-221-0392	C-6-1	4
81361	5-1-1489	4240-01-220-0553	C-2-1	2
81361	5-1-1490	4240-01-220-0550	C-6-1	KIT
81361	5-1-1522	5330-01-231-3877	C-3-1	3
81361	5-1-1762	5305-01-232-6728	C-4-1	2
81361	5-1-2094-10		C-3-1	2
81361	5-1-2095	5965-01-343-2543	C-7-1	1
81361	5-1-2529	4240-01-302-6742	C-2-1	5
81361	5-1-2789		C-1-1	2
81361	5-1-2849		C-1-1	3
81361	5-1-3301-10		C-1-1	1
81361	5-1-3301-20		C-1-1	1
81361	5-1-3301-30		C-1-1	1
81361	5-1-3301-40		C-1-1	1
81361	5-1-3370-10		C-2-1	1
81361	5-1-3370-20		C-2-1	1
81361	5-1-3370-30		C-2-1	1
81361	5-1-3370-40		C-2-1	1
81361	5-1-3382		C-9-1	4
81361	5-1-3383		C-9-1	2
81361	5-1-3384		C-9-1	1
81361	5-3-1520	4240-01-361-1319	C-2-1	6
57045	D6002571	5965-01-233-0355	C-7-1	3
81349	MIL-B-1963	8315-00-300-0327	C-1-1	5
81349	MIL-B-833	8440-01-204-2610	C-1-1	4
96906	MS16633-4006	5365-00-753-3868	C-5-1	1
96906	MS9068-032		C-6-1	3
80205	NAS1635-02LE4P	5305-01-178-6225	C-7-1	4

Cross-Reference Indexes

Figure and Item Index

FIG	ITEM	STOCK NUMBER	CAGEC	PART NUMBER
C-1-1	1		81361	5-1-3301-10
C-1-1	1		81361	5-1-3301-20
C-1-1	1		81361	5-1-3301-30
C-1-1	1		81361	5-1-3301-40
C-1-1	2		81361	5-1-2789
C-1-1	3		81361	5-1-2849
C-1-1	4	8440-01-204-2610	81349	MIL-B-833
C-1-1	5	8315-00-300-0327	81349	MIL-B-1963
C-2-1	1		81361	5-1-3370-10
C-2-1	1		81361	5-1-3370-20
C-2-1	1		81361	5-1-3370-30
C-2-1	1		81361	5-1-3370-40
C-2-1	1	4240-01-220-0553	81361	5-1-1489
C-2-1	2	4240-01-220-0560	81361	5-1-1305
C-2-1	3	4240-01-331-6153	81361	5-1-2423
C-2-1	4	4240-01-223-1395	81361	5-1-1312-1
C-2-1	4	4240-01-223-1396	81361	5-1-1312-2
C-2-1	4	4240-01-223-1397	81361	5-1-1312-3
C-2-1	4	4240-01-223-1398	81361	5-1-1312-4
C-2-1	5	4240-01-302-6742	81361	5-1-2529
C-2-1	6	4240-01-361-1319	81361	5-3-1520
C-3-1	1	4240-01-220-0552	81361	5-1-1339
C-3-1	2		81361	5-1-2094-10
C-4-1	1	4240-01-220-0548	81361	5-1-1443
C-4-1	2	5305-01-232-6728	81361	5-1-1762
C-5-1	1	5365-00-753-3868	96906	MS16633-4006
C-5-1	2	4820-01-260-8709	81361	5-1-1057
C-5-1	3	5315-01-232-6790	81361	5-1-1370
C-5-1	4		81361	5-1-1415
C-6-1	1		81361	5-1-1343
C-6-1	2		81361	5-1-1380
C-6-1	3		96906	MS9068-032
C-6-1	4	4240-01-221-0392	81361	5-1-1455
C-6-1	KIT	4240-01-220-0550	81361	5-1-1490
C-7-1	1	5965-01-343-2543	81361	5-1-2095
C-7-1	2	5965-01-230-8792	81361	5-1-1436
C-7-1	3	5965-01-233-0355	57045	D6002571
C-7-1	4	5305-01-178-6225	80205	NAS1635-02LE4P
C-8-1	1	5340-01-220-0664	81361	5-1-1303
C-9-1	1		81361	5-1-3384
C-9-1	2		81361	5-1-3383
C-9-1	3		81361	5-1-3385
C-9-1	4		81361	5-1-3382
C-3-1	3	5330-01-231-3877	81361	5-1-1522

**APPENDIX D
EXPENDABLE AND DURABLE ITEMS LIST**

Section I. INTRODUCTION

D-1. SCOPE.

This appendix lists expendable and durable items that you will need to operate and maintain the M48 Mask. This listing is for information only and is not authority to requisition the listed items. These items are authorized to you by CTA 50-970, Expendable/Durable Items (except medical, class V repair parts, and heraldic items), or CTA 8-100, Army Medical Department Expendable/Durable Items.

D-2. EXPLANATION OF COLUMNS.

a. Column (1) - Item Number. This number is assigned to the entry in the listing and is referenced in the narrative instructions to identify the item (e.g. "Use soap, Item 17, Appendix D").

b. Column (2) - Level. This column identifies the lowest level of maintenance that requires the listed item (C - Operator/Crew, O - Unit Maintenance, F - Direct Support Maintenance).

c. Column (3) - National Stock Number. This is the national stock number assigned to the item which you can use to requisition it.

d. Column (4) - Description. Indicates the item name, description, (CAGEC) and part number. This provides the other information you need to identify the item.

e. Column (5) - Unit of Measure (U/M). This code shows the physical measurement or count of an item, such as gallon (GL), each (EA), dozen (DZ), gross (GR), etc. If the unit of measure differs from the unit of issue, requisition the lowest unit of issue that will satisfy your requirements.

Section II. EXPENDABLE/DURABLE ITEMS

(1) Item Number	(2) Level	(3) National Stock Number	(4) Item Name, Description CAGEC and Part Number	(5) U/M
1	O	6515-01-234-6838	APPLICATOR,DISPOSABLE: Plastic or wood, cotton-tipped, 6.00 x 0.08 in. (15.24 x 0.21 cm) (5L934)362	PG
2	C	7920-00-061-0037	BRUSH,SCRUB (81348)H-B-1490-6-P1	EA
3	O	6665-00-978-5516	BRUSH,ASPIRATOR (40912)5607	EA
4	O	6810-00-255-0471	CALCIUM HYPOCHLORITE BT technical granular, 6 oz. Bottle (81348)OC114	
5	C	4240-00-930-2077	CAP, CANTEEN, Mi (81348)MIL-C-51278	EA
6	C	6850-00-270-6225	CHLORINATION KIT, WATER PURIFICATION (81348)O-C-289	KT
7	C	830500-222-2423	CLOTH, CHEESE: type 1, class 1 (81348)CCC-C-440	YD
8	O	8415-00-926-6696	GLOVES, CHEMICAL (81348)ZZ-G-381	PR
9	O	7510-00-224-6734	INK, MARKING STENCIL (81348)TT-I-1-795	PT
10	C	6505-00-655-8366	ISOPROPYL RUBBING ALCOHOL (56287)PUREPAC	BT

(1) Item Number	(2) Level	(3) National Stock Number	(4) Item Name, Description CAGEC and Part Number	(5) U/M
11	C	5110-00-240-5943	KNIFE, POCKET (81348)GGG-K-484	EA
12	O	8415-00-889-3654	MAINTENANCE KIT: toxicological Agent protective clothing (81349)MIL-C-51130	EA
13	O	6810-00-123-7047	n-AMYL ACETATE, REAGENT: clear, flammable liquid (81349)MIL-C-51130	PT
14	O	7240-01-094-4305	PAIL, UTILITY: plastic snap-on lid, 5 gal.(22.725L) (58536)A-A-332	EA
15	O	5315-01-330-8881	STAPLE KIT, IPD, 12 ea box (81361)5-1-2105	BX
16	O	6665-00-928-5731	SMOKE TUBE, 12 ea box (40912)BH5645	BX
17	C	8520-00-228-0598	SOAP, TOILET: Non-medicated, liquid, type 1, or equivalent (84748)Harco Liquid type 1, or equivalent (81348)P-S-624	GL

D-3 (D-4 blank)

INDEX

Subject	INDEX	Page
	A	
Abbreviations		1-2
Appendix A References.....		A-1
	B	
Battery Cap Assembly Replacement		2-61
Batteries PMCS		2-30
Blower Assembly		
Decontamination.....		2-65
PMCS.....		2-29
Repair.....		2-57
	C	
Canisters		
Inspection and Replacement		2-54
PMCS.....		2-28
Common Tools and Equipment		2-1
Control Knob Replacement		2-57
Corrosion Prevention and Control		1-2
Cross-Reference Indexes.....		C-I-1
	D	
Deliberate Decontamination		2-65
Destruction of Army Materiel to Prevent Enemy Use		1-2
Drinking System PMCS.....		2-25
	E	
Equipment Description and Data		2
Equipment Name and Model Number.....		1-1
Equipment/User Fitting Instructions.....		2-7
Expendable and Durable Items		D-2
Eyelens Cushion Replacement.....		246
	F	
Facepiece Assembly		
Adjustment		2-8
Decontamination		2-66
PMCS		2-18
Functional Test		2-15
Facepiece Carrier PMCS		2-32
Facepiece Hood Repair		244
Field Manuals		A-1
Forms		A-1
Forms and Records, Maintenance		1-1

Subject

Page

G	
General Information	1
H	
Hose PMCS	2-27
I	
Individual Mask Identification	2-6
Inlet Valve Assembly PMCS	2-20
Internal Drink Tube Replacement	247
Introduction to PMCS Procedures	-17
IPD Staple Kit	2-11
L	
Lenses PMCS	2-24
Linear Microphone and Microphone Adapter Replacement	2-51
List of Abbreviations	1-2
M	
Maintenance Allocation Chart	B-4
Maintenance Forms and Records	1-1
Maintenance Instructions.....	2-1
Maintenance Procedures.....	243
Mask Assembly Adjustment, Inspection, and Repair	2-44
Mask Assembly Functional Test	2-15
Mask Carrier	
Identification	2-6
PMCS	2-33
Strap Replacement.....	2-56
Mask Servicing	2-64
Microphone PMCS	2-26
Miscellaneous Publications	A-2
N	
Nomenclature Cross-Reference List.....	1-2
O	
Outlet Valve Assembly and Outlet Valve Cover PMCS	2-22
Outlet Valve Cover Replacement.....	2-50
Outlet Valve Disk Replacement.....	2-48

Subject	Page
P	
Port Gasket Replacement	2-59
Preparation for Storage or Shipment	1-1,2-62
Preventive Maintenance Checks and Services	2-17
Principles of Operation.....	1-3
Purpose of Equipment	1-1
R	
Recess Caps Replacement	2-61
References	A-1
Repair Parts	2-1
Repair Parts Special Tools List	C-1
Repair Parts, Special Tools (RPSTL), Test Measurement and Diagnostic Equipment (TMDE), and Support Equipment	2-1
Reporting Equipment Improvement Recommendations (EIR)	1-1
S	
Safety, Care, and Handling	1-1
Scope	1-1
Service Upon Receipt	
Checking Unpacked Equipment	2-5
General	2-1
Unpacking	2-2
Setscrew Adjustment and Replacement	2-53
Special Limitations on Equipment	1-1
Special Tools, TMDE, and Support Equipment	2-1
Strap Replacement, Blower Assembly	2-60
Suspension Harness PMCS	2-19
Swivel Assembly Gaskets Replacement	2-55
Staple Kit, IPD	2-11
T	
Technical Manuals	A-1
Tool and Test Equipment Requirements	B-5
Troubleshooting	
Insufficient/No Air to User	2-36
Poor/No Hood Ventilation	2-39
Poor/No Lens Defogging	2-38
Microphone Inoperative	2-40
Type of Manual	1-1
U	
Unit Maintenance Repair Parts and Special Tools List	C-1

Subject

Page

V

Voicemitter

PMCS2-23

Replacement2-47

W

Web Belt Adjustment2-14

Index-4

By Order of the Secretary of the Army:

Official:

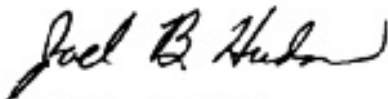

JOEL B. HUDSON
Administrative Assistant to the
Secretary of the Army
03831

DENNIS J. REIMER
General, United States Army
Chief of Staff

DISTRIBUTION:

To be distributed in accordance with the initial distribution number (IDN) 280809 requirements for TM 3-4240-342-20&P.

*U.S. GOVERNMENT PRINTING OFFICE:1997-545-036/60501

RECOMMENDED CHANGES TO EQUIPMENT TECHNICAL PUBLICATIONS



THEN... JOT DOWN THE DOPE ABOUT IT ON THIS FORM, CAREFULLY TEAR IT OUT, FOLD IT AND DROP IT IN THE MAIL!

SOMETHING WRONG WITH THIS PUBLICATION?

FROM: (PRINT YOUR UNIT'S COMPLETE ADDRESS)

DATE SENT

PUBLICATION NUMBER

PUBLICATION DATE

PUBLICATION TITLE

BE EXACT... PIN-POINT WHERE IT IS

PAGE NO.

PARA-GRAPH

FIGURE NO.

TABLE NO.

IN THIS SPACE TELL WHAT IS WRONG AND WHAT SHOULD BE DONE ABOUT IT:

TEAR ALONG PERFORATED LINE

PRINTED NAME, GRADE OR TITLE, AND TELEPHONE NUMBER

SIGN HERE:

DA FORM 2028-2
1 JUL 79

PREVIOUS EDITIONS ARE OBSOLETE.

P.S.—IF YOUR OUTFIT WANTS TO KNOW ABOUT YOUR RECOMMENDATION MAKE A CARBON COPY OF THIS AND GIVE IT TO YOUR HEADQUARTERS.

