

UNIT MAINTENANCE MANUAL  
(INCLUDING REPAIR PARTS AND SPECIAL TOOLS LIST)  
FOR  
MASK, CHEMICAL-BIOLOGICAL: FIELD

ABC-M17	(4240-00-542-4450-SMALL) (4240-00-542-4451-MEDIUM) (4240-00-542-4452-LARGE)
M17A1	(4240-00-926-4199-SMALL) (4240-00-926-4201-MEDIUM) (4240-00-926-4200-LARGE)
M17A2	(4240-01-143-2017-X-SMALL) (4240-01-143-2018-SMALL) (4240-01-143-2019-MEDIUM) (4240-01-143-2020-LARGE)

**WARNING:** This document contains export-controlled technical data whose export is restricted by the Army Export Control Act (Title 22, U.S.C., Sec 2751 et seq) or Executive Order 12470. Violation of these export laws are subject to severe criminal penalties.

**DISTRIBUTION STATEMENT C:** Distribution authorized to U.S. Government agencies and their contractors to protect technical or operational information from automatic dissemination under the International Exchange Program or by other means. This determination was made on 10 March 1987. Other requests for this document will be referred to: Director, Armament and Chemical Acquisition and Logistics Activity, ATTN: AMSTA-AC-MASL, Rock Island, IL 61299-7630.

**DESTRUCTION NOTICE:** Destroy by any method that will prevent disclosure of contents or reconstruction of the document.

---

HEADQUARTERS, DEPARTMENT OF THE ARMY

5 OCTOBER 1987

## **WARNING**

The M17/M17A1/M17A2 facepiece will not protect the wearer against ammonia or carbon-monoxide gases. The facepiece will not protect the wearer in confined spaces where the oxygen content of the air is too low.

Do NOT wear contact lenses when wearing a protective mask with prescription optical inserts. Wearing both will overcorrect and impair vision.

Before putting on and adjusting mask, female soldiers shall remove all hairpins, combs, hair knots, buns, or braids that will interfere with facepiece seal. Male soldiers must be clean shaven to prevent mask leaks.

Do NOT touch your skin (or the soldier) with n-Amyl acetate (banana oil). It could irritate the skin. Wear rubber gloves if an application could wet your fingers.

Do NOT smoke around n-Amyl acetate (banana oil). Keep n-Amyl acetate away from an open flame. IT CAN CATCH FIRE.

Do NOT test facepiece in a closed, poorly ventilated area. Test outdoors or in a well aired room. n-Amyl acetate may be toxic if inhaled in quantity.

Do NOT use facepiece if inlet valve assemblies or inlet valve disks are missing. Facepiece may leak.

### **FIRST AID**

For first aid, refer to FM 21-11.

CHANGE

NO. 4

HEADQUARTERS  
DEPARTMENT OF THE ARMY  
Washington D.C., 11 October 1995

**UNIT MAINTENANCE MANUAL  
(INCLUDING REPAIR PARTS AND SPECIAL TOOLS LIST)  
FOR  
MASK, CHEMICAL-BIOLOGICAL: FIELD  
ABC-M17/M17A1/M17A2**

TM 3-4240-279-20&P is changed as follows:

1. New or changed material in the narrative is indicated by a vertical bar in the margin of the page.
2. Added or revised illustrations are indicated by a pointing finger on the illustration,
3. New or changed material in the Repair Parts Special Tools List is indicated by a vertical bar in the left margin.
4. Remove old pages and insert new pages as indicated below:

**Remove Pages**

i and ii  
1-1 and 1-2  
2-15 thru 2-20  
NONE  
2-25 thru 2-26  
2-45 and 2-46  
Figure C-1 thru C-2-1  
1-1 and 1-2  
D-1 thru D-3/(D-4 blank)  
Index 1 and Index 2  
DA Form 2028-2 (With address)  
Front Cover and Warning  
Back Cover

**Insert Pages**

i and ii  
1-1 and 1-2  
2-15 thru 2-20  
2-22.1/(2-22.2 blank)  
2-25 thru 2-26.1/(2-26.2 blank)  
2-45 and 2-46  
Figure C-1 thru C-2-1  
I-1 and I-3/(I-4 blank)  
D-1 thru D-3/(D-4 blank)  
Index 1 and Index 2  
DA Form 2028-2 (With address)  
Front Cover and Warning  
Metric Chart and Back Cover,

5. File this change sheet in front of the publication for reference purposes.

By Order of the Secretary of the Army:

**DENNIS J. REIMER**  
*General, United States Army*  
*Chief of Staff*

Official:

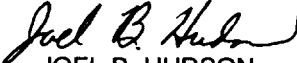
  
JOEL B. HUDSON  
*Acting Administrative Assistant to the*  
*Secretary of the Army*  
00815

DISTRIBUTION: To be distributed in accordance with DA Form 12-28E (Block 0434), Unit Maintenance Requirements for TM 3-4240-279-20&P.

CHANGE

NO. 3

HEADQUARTERS  
DEPARTMENT OF THE ARMY  
WASHINGTON, DC, 30 September 1991

UNIT MAINTENANCE MANUAL  
(INCLUDING REPAIR PARTS AND SPECIAL TOOLS LIST)  
FOR  
MASK, CHEMICAL-BIOLOGICAL: FIELD  
ABC-M17/M17A1/M17A2

TM 3-4240-279-20&P, 5 October 1987, and changes 1 and 2 are changed as follows:

1. The purpose of this change is to update shipping instructions.
2. New or changed material in the narrative is indicated by a vertical bar in the margin of the page.
3. Remove old pages and insert new pages as follows:

Remove Pages

2-51 and 2-52  
D-3 (D-4 blank)

Insert Pages

2-51 and 2-52  
D-3 (D-4 blank)

4. File this transmittal sheet in front of the publication for reference purposes.

By Order of the Secretary of the Army:

GORDON R. SULLIVAN  
General, United States Army  
Chief of Staff

Official:

PATRICIA P. HICKERSON  
Brigadier General, United States Army  
The Adjutant General

DISTRIBUTION:

To be distributed in accordance with DA Form 12-34-E, (Block 0434), Unit Maintenance Requirements for TM 3-4240-279-20&P.

CHANGE

NO. 2

HEADQUARTERS  
DEPARTMENT OF THE ARMY  
WASHINGTON, DC, 15 November 1989

UNIT MAINTENANCE MANUAL  
(INCLUDING REPAIR PARTS AND SPECIAL TOOLS LIST)  
FOR  
MASK, CHEMICAL-BIOLOGICAL: FIELD  
ABC-M17/M17A1/M17A2

TM 3-4240-279-20&P, 5 October 1987, is changed as follows:

1. The purpose of this change is to update guidance for disposal, handling, and storage of filter elements used with the M17 Mask.
2. New or changed material in the narrative is indicated by a vertical bar in the margin of the page.
3. New or changed material in the Repair Parts Special Tools List is indicated by an asterisk in the left margin.
4. Remove old pages and insert new pages as follows:

<u>Remove Pages</u>	<u>Inserts Pages</u>
None	a/(b blank)
2-15 thru 2-18	2-15 thru 2-18
2-25 and 2-26	2-25 and 2-26
C-1-1 thru C-2-1	C-1-1 thru C-2-1
I-1 and I-2	I-1 and I-2

5. File this transmittal sheet in front of the publication for reference purposes.

By Order of the Secretary of the Army:

CARL E. VUONO  
General, United States Army  
Chief of Staff

Official:

WILLIAM J. MEEHAN II  
Brigadier General, United States Army  
The Adjutant General

Distribution:

To be distributed in accordance with DA Form 12-28, quantity required block 434, TM 3-4240-279-20&P.

CHANGE

NO. 1

HEADQUARTERS  
DEPARTMENT OF THE ARMY  
WASHINGTON, DC, 29 April 1989

UNIT MAINTENANCE MANUAL  
(INCLUDING REPAIR PARTS AND SPECIAL TOOLS LIST)  
FOR  
MASK, CHEMICAL-BIOLOGICAL: FIELD  
ABC-M17/M17A1/M17A2

TM 3-4240-279-20&P, 5 October 1987, is changed as follows:

1. New or changed material is indicated by a vertical bar in the margin of the page.
2. Added or revised illustrations are indicated by a vertical bar in the margin of the page.
3. Remove old pages and insert new pages as indicated below:

Remove Pages

1-1 and 1-2  
2-7 thru 2-12  
2-19 and 2-20  
2-23 and 2-24  
2-51 and 2-52  
A-1 (A-2 blank)

Insert Pages

1-2 and 1-2  
2-7 thru 2-12  
2-19 and 2-20  
2-23 and 2-24  
2-51 and 2-52  
A-1 (A-2 blank)

4. File this change sheet in front of the publication for reference purposes.

BY ORDER OF THE SECRETARY OF THE ARMY:

CARL E. VUONO  
General, United States Army  
Chief of Staff

OFFICIAL:

WILLIAM J. MEEHAN II  
Brigadier General, United States Army  
The Adjutant General

DISTRIBUTION:

To be distributed in accordance with DA Form 12-28, quantity required block 434, TM 3-4240-279-20&P.

WARNING

HEALTH/ENVIRONMENTAL HAZARD

Filters use ASC Whetlerite Carbon which contains Chromium VI. Chromium VI is a known carcinogen if inhaled or swallowed. Damaged or unusable filters are classified as hazardous waste:

DO NOT throw away damaged or unusable filters as ordinary trash.

DO turn in damaged or unusable canisters to your hazardous waste management office or Defense Reutilization and Marketing Office (DRMO).

Filters are completely safe to handle and use if they are not damaged in such a way that carbon leaks from them. In unlikely event that carbon should leak, use protection such as a dust respirator to cover nose and mouth and put carbon in container such as self-sealing plastic bag; turn in to hazardous waste management office or DRMO.

Disposal of hazardous waste is restricted by the Resource Conservation and Recovery Act as amended (42 U.S.C.A sec 6901 et seq). Violation of these laws is subject to severe criminal penalties.



Technical Manual

No. 3-4240-279-20&P

HEADQUARTERS  
DEPARTMENT OF THE ARMY  
Washington, DC 5 October 1987

Unit Maintenance Manual  
Including Repair Parts and Special Tools List  
FOR  
MASK, CHEMICAL-BIOLOGICAL: FIELD

ABC-M17	(4240-00-542-4450-SMALL) (4240-00-542-4451-MEDIUM) (4240-00-542-4452-LARGE)
M17A1	(4240-00-926-4199-SMALL) (4240-00-926-4201-MEDIUM) (4240-00-926-4200-LARGE)
M17A2	(4240-01-143-2017-X-SMALL) (4240-01-143-2018-SMALL) (4240-01-143-2019-MEDIUM) (4240-01-143-2020-LARGE)

Current as of 7 August 1995 for Appendix C

**REPORTING ERRORS AND RECOMMENDING IMPROVEMENTS**

You can help Improve this manual. If you find any mistakes, or If you know of a way to Improve the procedures, please let us know. Mail your letter, DA Form 2028 (Recommended Changes to Publications and Blank Forms), or DA Form 2028-2 located In the back of this manual direct to: Director, Armament and Chemical Acquisition and Logistics Activity, ATTN: AMSTA-AC-MASL, Rock Island, IL. 61299-7630. A reply will be furnished to you.

		Page
<b>CHAPTER 1</b>	<b>INTRODUCTION</b> .....	1-1
Section I	General Information.. ..	1-1
Section II	Equipment Description and Data.. ..	1-1
Section III	Principles of Operation.. ..	1-9
<b>CHAPTER 2</b>	<b>MAINTENANCE INSTRUCTIONS</b>	
Section I	Repair Parts, Special Tools, TMDE, and Support Equipment....	2-1
Section II	Service Upon Receipt.. ..	2-1
Section III	Equipment/User Fitting Instructions.. ..	2-3
Section IV	Preventive Maintenance Checks and Services (PMCS) .....	2-11
Section V	Checking Facepiece for Leaks.. ..	2-24
Section VI	Maintenance Procedures.. ..	2-27
Section VII	Cleaning and Sanitizing Mask.. ..	2-46
Section VIII	Preparation for Storage or Shipment.. ..	2-52

\*This manual supersedes TM 3-4240-279-20&P, 2 March 1983, and all of its changes.

		Page	ILLUS Figure
<b>APPENDIX A</b>	<b>REFERENCES</b> .....	A-1	
<b>APPENDIX B</b>	<b>MAINTENANCE ALLOCATION CHART</b> .....	B-1	
<b>APPENDIX C</b>	<b>REPAIR PARTS AND SPECIAL TOOLS LIST</b>		
Section I	Introduction .....	C-1	
Section II	Repair Parts List.....	C-1-1	
Group 00	Mask Chemical-Biological: Field, M17, M17A1, M17A2 .....	C-1-1	C-1
Group 01	Facepiece Assembly M17 Mask, M17A1/M17A2 Mask .....	C-2-1	C-2
	0101 Inlet Valve Assembly.....	C-2-1	C-2
Section III	Special Tools List (Not Applicable).....	C-2-1	
Section IV	National Stock Number, Part Number and Figure and Item Number Indexes.....	1-1	
<b>APPENDIX D</b>	<b>EXPENDABLE/DURABLE SUPPLIES AND MATERIALS LIST</b> .....	D-1	
<b>APPENDIX E</b>	<b>ILLUSTRATED LIST OF MANUFACTURED ITEMS</b> .....	E-1	
	<b>ALPHABETICAL INDEX</b> .....	Index 1	
	<b>MEASURING SCALES FOR MASK SIZING TOOL</b> .....	Inside Back Cover	

## CHAPTER 1 INTRODUCTION

### Section I. GENERAL INFORMATION

#### 1-1. SCOPE.

- a. *Type of Manual.* Unit Maintenance.
- b. *Model Numbers and Equipment Names.*  
Mask, chemical-biological: field, ABC-M17, M17A1 and M17A2.
- c. *Purpose of Equipment.* M17/M17A1/M17A2. chemical-biological field masks protect the face, eyes, and respiratory tract of the wearer from field concentrations of chemical and biological (CB) agents.
- d. *Limitations.* The masks do not protect the wearer from ammonia or carbon-monoxide gases. They are not effective in confined spaces where the oxygen content of the air is too low to maintain functional capability (below 18 percent). Refer to TB MED 502 for proper respiratory protection devices.

#### 1-2. MAINTENANCE FORMS, RECORDS, AND REPORTS.

Department of the Army forms and procedures used for equipment maintenance will be those prescribed by DA PAM 738-750, The Army Maintenance Management System (TAMMS), as contained in Maintenance Management Update.

#### 1-3. DESTRUCTION OF ARMY MATERIEL TO PREVENT ENEMY USE.

Refer to TM 43-0002-31 for methods of destruction.

#### 1-4. PREPARATION FOR STORAGE OR SHIPMENT

Refer to Chapter 2, Section VIII for administrative storage instructions on masks.

#### 1-5. REPORTING EQUIPMENT IMPROVEMENT RECOMMENDATIONS.

If your mask needs improvement, let us know. Send us an EIR. You, the user, are the only one who can tell us what you don't like about your equipment. Let us know why you don't like the design. Put it on an SF 368, Quality Deficiency Report (QDF). Mail it to us at Commander, U.S. Army Armament Research, Development and Engineering Center, ATTN: AMSTA-AR-QAW (R), Rock Island, IL 61299-7300. We'll send you a reply.

### Section II. EQUIPMENT DESCRIPTION AND DATA

#### 1-6. EQUIPMENT CHARACTERISTICS, CAPABILITIES, AND FEATURES.

- a. *Characteristics.*
  - (1) Lightweight.
  - (2) Transported and stored in carrier.
  - (3) Faceblank is made of rubber so that it can form a seal on your face.
- b. *Capabilities and Features.*
  - (1) Masks provide protection to face, eyes, and respiratory tract from CB agents
  - (2) M17A1/M17A2 mask has a voicemitter-outlet valve assembly equipped with a drinking system.
  - (3) Items are authorized for increased protection (hood), for winterizing (M4 winterization kit), and for personnel who must wear glasses (optical inserts).
  - (4) M17/M17A1 mask is issued in three sizes: small, medium, and large. The small mask is

- marked S on the faceblank and M on the nosecup assembly. The medium mask is marked M on the faceblank and M on the nosecup assembly. The large mask is marked M on the faceblank and L on the nosecup assembly.
- (5) M17A2 mask is issued in four sizes: extra small, small, medium and large. Extra small mask is marked XS on faceblank and X on nosecup assembly. The small mask is marked S on faceblank and M on nosecup assembly. The medium mask is marked M on the faceblank and M on the nosecup assembly. The large mask is marked M on the faceblank and L on the nosecup assembly. The earlier version of the extra small M17A2 has a full intumed lip periphery. The later version has a 3/4 intumed lip periphery.

1-7. LOCATION AND DESCRIPTION OF MAJOR COMPONENTS.

- (A) FACEPIECE ASSEMBLY. The facepiece assembly consists of the following parts: faceblank, eyelenses, head harness, crimping rings, filter elements, flap buttons, temple pins, clip and buckle assemblies inlet valves, inlet valve disks, nosecup assembly, voicemitter-outlet valve assembly, and a quick disconnect coupling half and end strap clips.

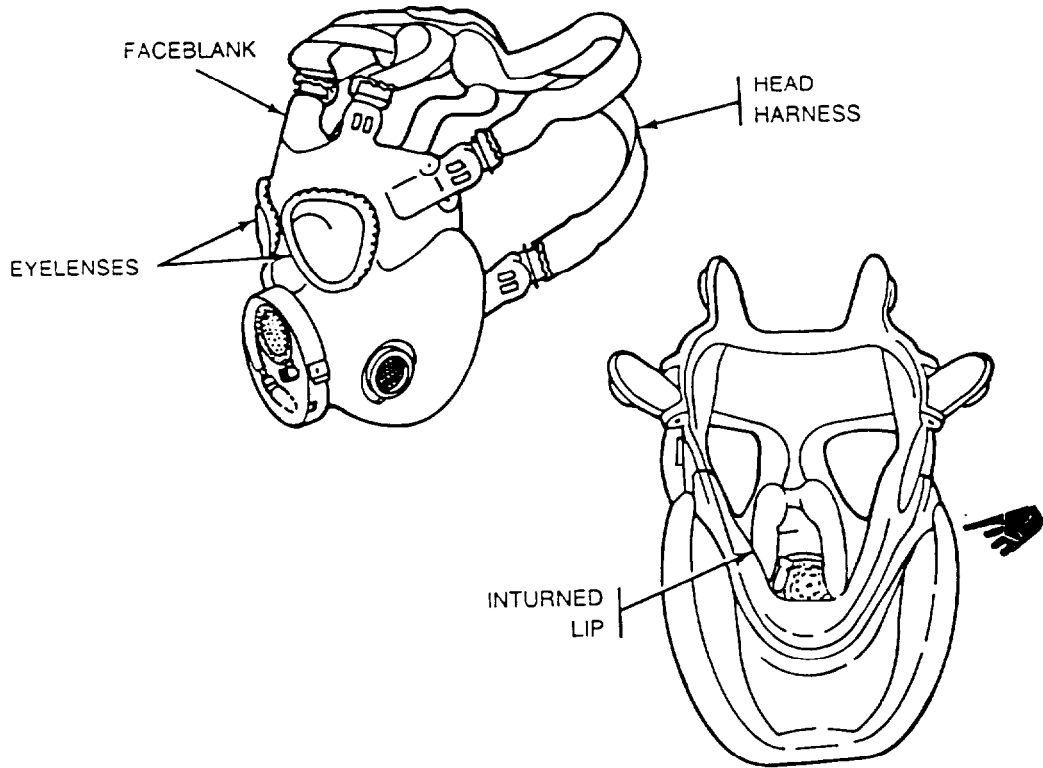

- FACEBLANK. The following are molded into the rubber faceblank: filter element pouches, flap-button buttonholes, clip and buckle tabs, temple pin lugs, deflector tubes, support blocks with positioning holes for optical inserts (M17A1/M17A2 masks only), faceblank openings for eyelenses, nosecup assembly, voicemitter-outlet valve assembly, and filter element connectors.
- INTURNED LIP. The M17A2 faceblank (extra-small size only) has an inturned lip at the periphery (face seal).

- EYELENSES. Clear plastic eyelenses are sealed in the faceblank openings by metal eyerings.
- HEAD HARNESS. The head harness consists of elastic webbing sewn to a rectangular head pad. The head harness is buckled to the faceblank. The ends of the head harness straps have metal end clips to prevent raveling of the elastic webbing. Ends of the head harness straps pass through clip and buckle assemblies at the two forehead, temple, and cheek positions. Elastic webbing connects the two forehead straps and holds them in proper alignment when the faceblank is worn. The clip and buckle assemblies at the ends of the tabs permit adjustment of the head harness straps to obtain proper fit at the faceblank.
- CRIMPING RINGS. Metal crimping rings seal the frame of the voicemitter-outlet valve assembly and noseclip assembly to the faceblank. The two studs on the crimping rings hold the voicemitter-outlet valve assembly covers in place.

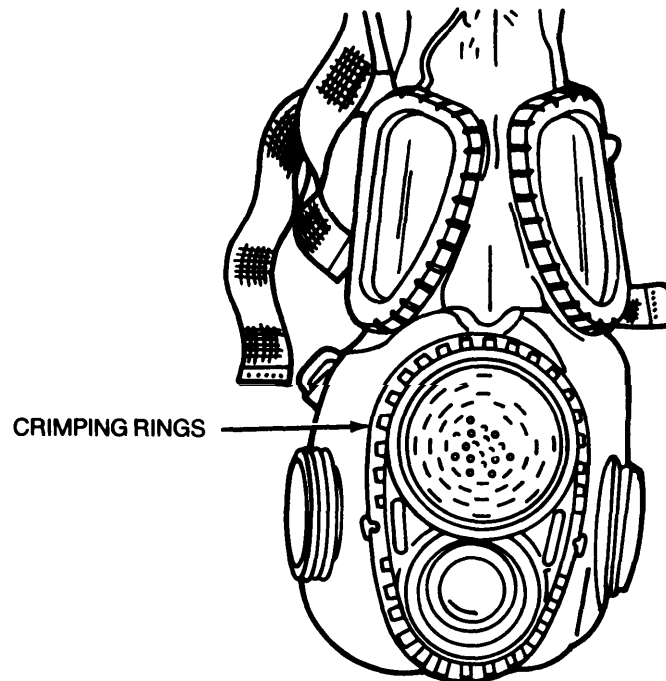

- **FILTER ELEMENTS.** Filter elements are made in matched pairs. One filter element, marked RIGHT, fits into the right filter element pouch in the mask. The other filter element, marked LEFT, fits into the left filter element pouch. Both filter elements are marked with the same lot number. Filtering material in the filter elements filters toxic chemical agents, biological agents, and other particles from inhaled air. A connector on each filter element directs the incoming air through the filtering material. An inlet valve is mounted on each connector.

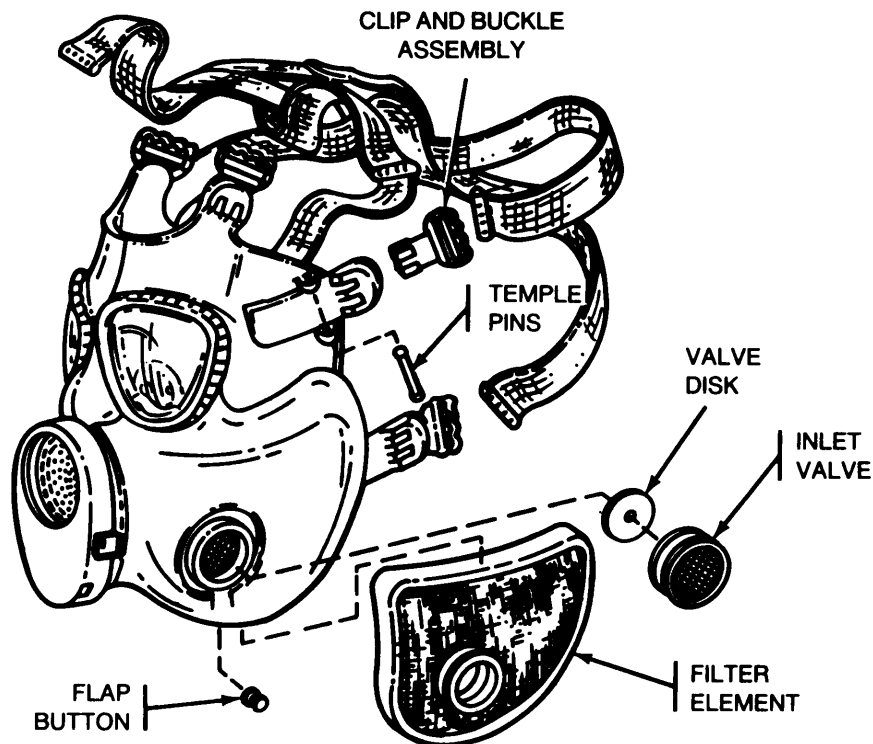

- **FLAP BUTTONS.** The plastic short and long flap buttons are used to button the filter element pouch flaps after filter elements are installed. The short flap buttons are located near the edge of the facepiece. The long flap buttons are located near the nosecup assembly. The long flap buttons are buttoned to the nosecup assembly to hold it firmly to the inside of the facepiece.
- **TEMPLE PINS.** The rubber temple pins pass through temple pin lugs in the faceblank to hold the temple tabs in proper position against the faceblank.
- **CLIP AND BUCKLE ASSEMBLIES.** Six metal clip and buckle assemblies are attached to clip and buckle tabs on the faceblank (two at forehead, two at temple, and two at cheek positions). The bent ends of the clip and buckle assemblies pass through openings in the side edges of the rubber clip and buckle tabs to hold the clip and buckle assemblies in place.
- **INLET VALVES AND VALVE DISKS.** Inhaled air enters the mask through the inlet valves and filter elements. A nonmetallic valve disk inside each inlet valve allows contaminated air to enter the filters and prevents moist exhaled air inside the facepiece from flowing out the inlet valves. The inlet valves are covered with rain repellent mesh material to protect the filter elements from rain and snow. The louvers inside the inlet valves are horizontal to direct rain or snow away from filter elements. The word TOP is printed on each inlet valve rim for positioning it on the connector so the louvers inside the inlet valves are horizontal.

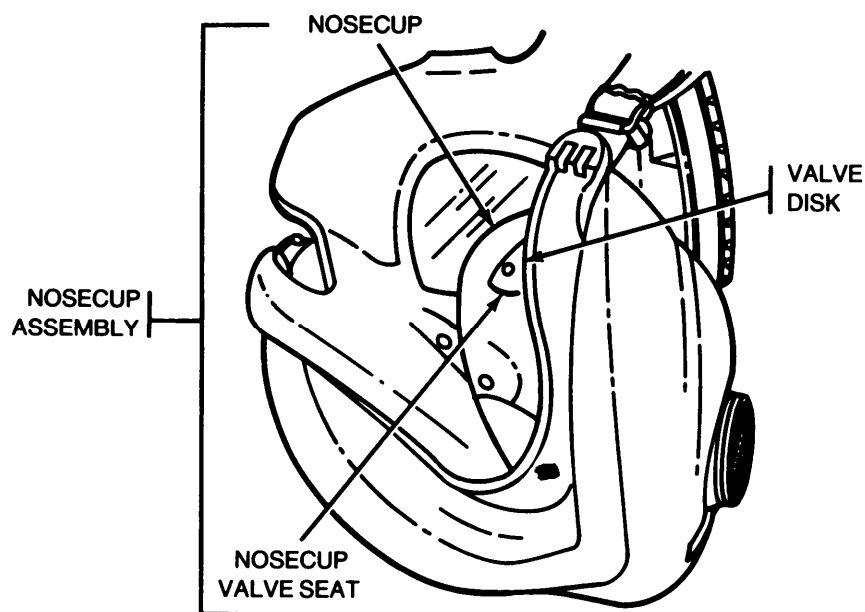

- NOSECUP ASSEMBLY. The nosecup assembly consists of a nosecup, two nosecup valve seats, and two valve disks. The nosecup assembly allows filtered air to enter nosecup and prevents moist exhaled air from fogging the eyelenses in cold weather.
- NOSECUP. The soft rubber nosecup fits over the soldier's nose and mouth. It diverts the exhaled air toward the outlet valve to help prevent fogging of the eyelenses.
- NOSECUP VALVE SEAT. Each of two nosecup valve seats holds a nonmetallic valve disk.
- VALVE DISK. One of two nonmetallic valve disks and a valve seat make up the nosecup valve assembly.

- VOICEMITTER-OUTLET VALVE ASSEMBLY. The M17, M17A1, or M17A2 mask voicemitter-outlet valve assembly consists of a voicemitter, voicemitter-outlet valve assembly cover, and an outlet valve with a nonmetallic outlet valve disk. The M17A1/M17A2 mask voicemitter-outlet valve assembly also has an adapter, lever, and drinking mouthpiece. A quick disconnect coupling half, consisting of a coupling and length of hose (tube for water intake), fits over the adapter on the M17A1/M17A2 model. The lever controls the movement of the drinking mouthpiece on the M17A1/M17A2 facepiece.

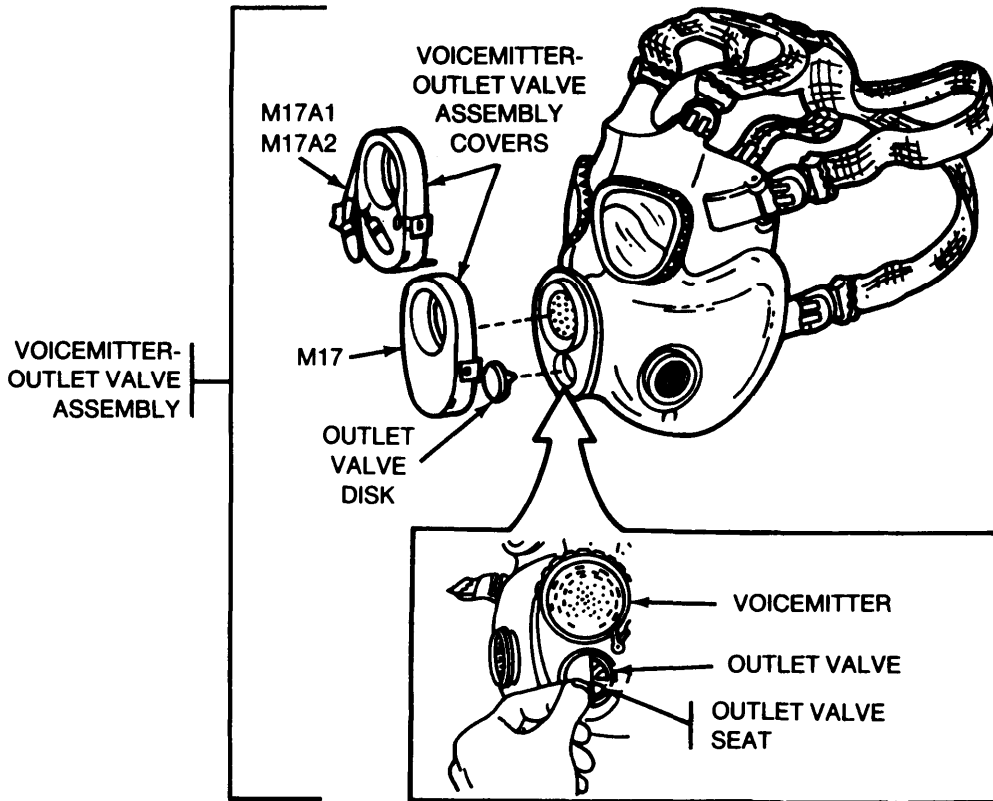

- VOICEMITTER. The voicemitter transmits the soldier's voice outside the facepiece.
- VOICEMITTER-OUTLET VALVE ASSEMBLY COVER. The M17, M17A1, or M17A2 mask rubber voicemitter-outlet valve assembly cover fits over the voicemitter-outlet valve assembly. The cover surrounds the nonmetallic outlet valve disk with an atmosphere of uncontaminated exhaled air. Air is expelled from the mask through air passages in the bottom of the cover. A lifting tab at the bottom allows the lower portion to be lifted without removing the cover. Two small openings at the sides of the cover fit over studs or the crimping ring. An opening on the face of the cover fits around the voicemitter. The cover on the M17A1/M17A2 facepiece has another smaller opening on its face that fits behind a hex nut at the base of the lever. An opening in a channel provides a passage through the cover for the quick disconnect coupling half. The channel and a pocket hold the quick disconnect coupling half when not in use.
- OUTLET VALVE. The outlet valve consists of a metal outlet valve seat and a nonmetallic outlet valve disk.
- OUTLET VALVE SEAT. The outlet valve seat permits attachment of the outlet valve disk.
- OUTLET VALVE DISK. The outlet valve disk allows exhaled air to escape and prevents inhaled air from entering the facepiece.



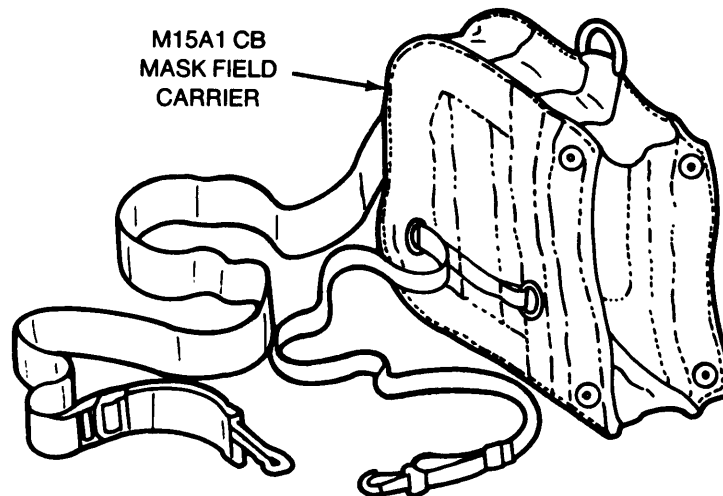

- B** M15A1 CB MASK FIELD CARRIER. The M15A1 CB mask field carrier is made of mildew-resistant, water-repellent cotton duck. It is lined and reinforced at critical locations to protect the mask. The carrier is worn on the left side in either a shoulder-carry or a leg-carry. The outside of the carrier has a snap flap at the front and three pockets with snap flaps. Two pockets (upper and lower) are located at the back of the carrier. The third pocket is located on the bottom.

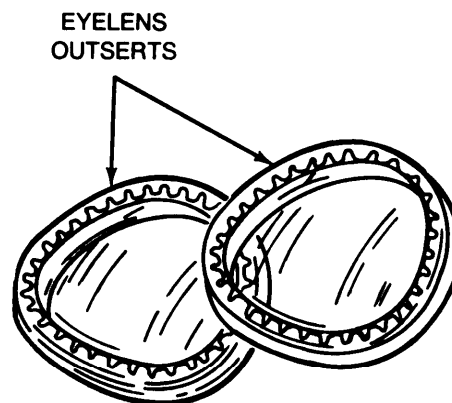

- C** EYELENS OUTSERTS. Two identical eyelens outserts are packaged in a plastic pouch. Each plastic eyelens outsert is seated in a soft rubber ring that fits over the facepiece eyering. The rim of the ring fits snugly behind the eyering. When the mask is issued, the eyelens outserts are to be removed from inside pocket of carrier and mounted on the facepiece to protect the facepiece eyelenses from scratches. The eyelens outserts also serve as a storm window to reduce fogging.

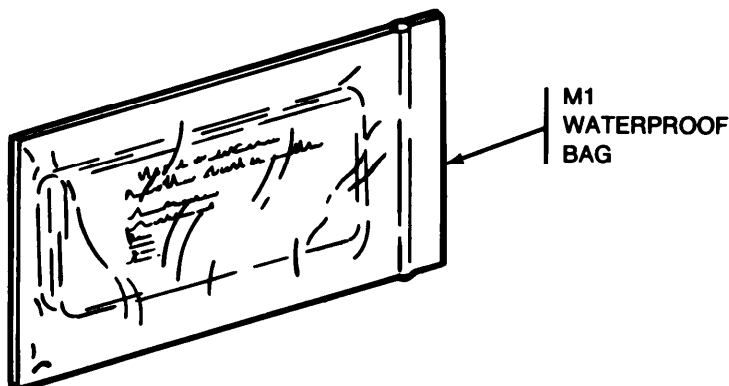

- (D) **M1 WATERPROOF BAG.** The plastic M1 waterproof bag is used in a hot humid climate to keep the mask dry. The folded M1 waterproof bag and a small envelope containing three rubber bands are packed in a small pouch in lower pocket of carrier. Instructions for use are printed on the M1 waterproof bag.

**NOTE**

An M1A1 waterproof bag may be issued in place of the M1 waterproof bag. The use is the same.

**1-8. DIFFERENCES BETWEEN MODELS.**

a. Throughout this manual, the term mask refers to M17, M17A1, and M17A2 masks. When data applies to one model only, the model will be specifically identified.

b. The voicemitter-outlet valve assembly for the M17A1/M17A2 facepiece assembly is equipped with a drinking system. Also, the M17A1/M17A2 mask facepiece assembly has supports with positioning holes for optical inserts. The M17A2 mask also comes in extra small size.

*Differences Between Models*

MASK FEATURES	M17	M17A1	M17A2
<b>Drinking system</b>	-	X	X
<b>Prong type optical inserts</b>	-	X	X
<b>Wire frame optical inserts</b>	X	X	X
<b>Optical insert supports</b>	-	X	X
<b>Extra small size</b>	-	-	X
<b>Resuscitation mouthpiece</b>	-	X	-

**1-9. EQUIPMENT DATA.**

a. *Tabulated Data.*

Weight (with carrier):

M17 mask . . . . . 2.93 lb (1 .33 kg)

M17A1/M17A2 mask.. 3.11 lb (1.41 kg)

Dimensions (in carrier) . .5.5 x 7.5 x 11 in.  
(13.97 x 19.05 x 27.94 cm)

b. *Shipping and Storage Data.*

Number and type of pack. . 10 per fiberboard  
or wooden box

Fiberboard box:

Weight . . . . . 43 lb(19.50 kg)

cube . . . . . .3.3 cu ft (0.09 cu m)

Wooden box:

Weight . . . . . .66 lb(29.94 kg)

cube . . . . . 4 cu ft(0.11 cu m)

### Section III. PRINCIPLES OF OPERATION

#### 1-10. PRINCIPLES OF OPERATION.

**WARNING**

The M17/M17A1/M17A2 facepiece will not protect the soldier against ammonia or carbon monoxide gases. The facepiece will not protect the soldier in confined spaces where the oxygen content of the air is too low.

The M17, M17A1, and M17A2 facepiece consists of a rubber faceblank (1) which fits closely against face to

form a seal. Air enters the filter element pouches from the filter elements (2) and passes through the deflector tubes into the eye area of the facepiece. The filter elements then filter out toxic chemical agents, biological agents, and other particles from inhaled contaminated air. From the eye area, the air enters the nosecup assembly (3) through the valve disks (4) and nosecup valve seats (5). Air from the nosecup is inhaled by the soldier. Exhaled air passes through the nosecup area and out through the outlet valve (6). The voicemitter-outlet valve assembly cover (7) surrounds the outlet valve with uncontaminated exhaled air.

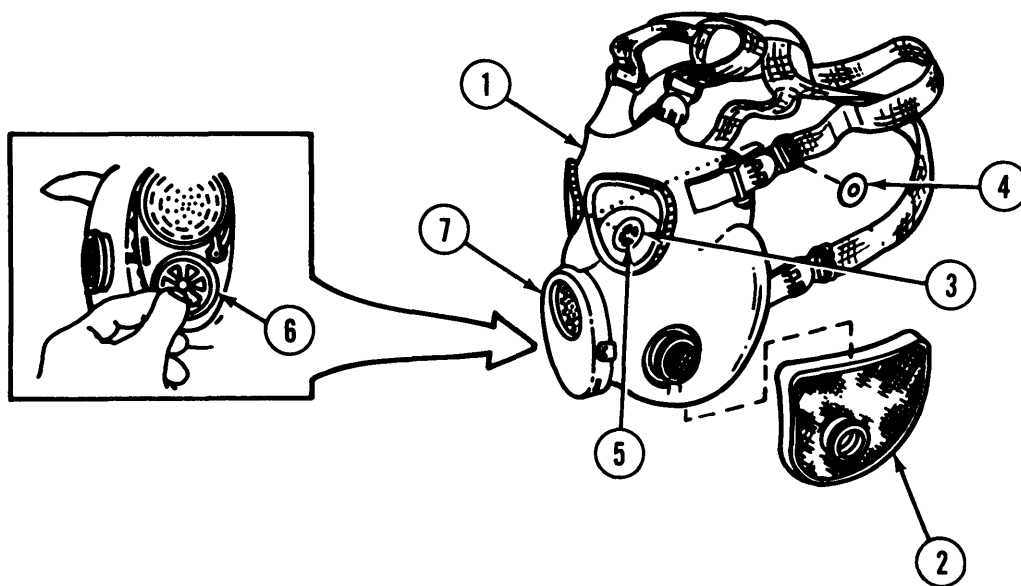

## CHAPTER 2 MAINTENANCE INSTRUCTIONS

---

### Section I. REPAIR PARTS, SPECIAL TOOLS, TMDE, AND SUPPORT EQUIPMENT

#### NOTE

All maintenance procedures in this manual may be performed by operator under proper supervision.

#### 2-1. COMMON TOOLS AND EQUIPMENT.

For authorized common tools and equipment, refer to the Modified Table of Organization and Equipment (MTOE) applicable to your unit.

#### 2-2. SPECIAL TOOLS, TMDE, AND SUPPORT EQUIPMENT.

Refer to appendix C (RPSTL) and appendix E (Illustrated List of Manufactured Items).

#### 2-3. REPAIR PARTS.

Repair parts are listed and illustrated in appendix C of this manual.

### Section II. SERVICE UPON RECEIPT

#### 2-4. GENERAL

a. When new or reconditioned masks are received, it is the responsibility of the officer or NBC NCO in charge to determine if the masks have been properly prepared for service by the supplying organization and that the masks are in condition to perform their mission.

b. Ten masks, in their carriers, are packed in a fiberboard box which may be packed in a cleated plywood box.

2-5. SERVICE UPON RECEIPT.

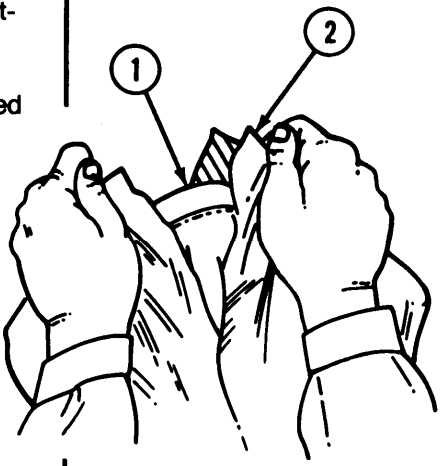
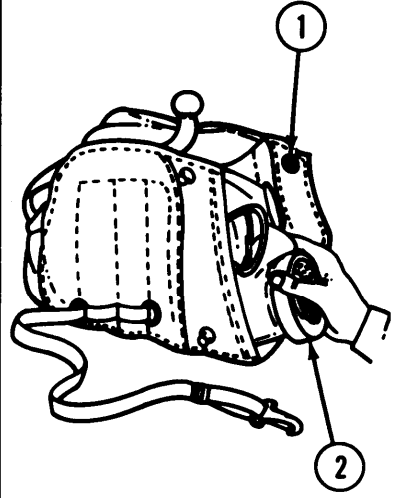
LOCATION	ITEM	ACTION	REMARKS
<b>UNPACKING</b>			
1. Plywood box	a. Lid	Remove end and side fasteners. Lift off lid.	Retain box, lid, and fasteners for reshipping or storage.
	b. Inner fiberboard box	Open and remove carrier or heat-sealed bag.	
2. Heat-sealed bag (if present)	Carrier	Take carrier (1) out of heat-sealed bag (2) and throw away heat-sealed bag.	
<b>INSPECTION</b>			
3. Carrier	Mask/M1 waterproof bag and eyelens outserts	<p>a. Open carrier (1). Take out mask (2). Be sure M1 waterproof bag and eyelens outserts are in carrier.</p> <p>b. Inspect the equipment for damage incurred during shipment. If the equipment has been damaged, report the damage on SF 364, Report of Discrepancy (ROD).</p> <p>c. Check the equipment against the packing slip to see if the shipment is complete. Report all discrepancies in accordance with the instructions of DA PAM 738-750, The Army Maintenance Management System (TAMMS).</p> <p>d. Check to see whether the equipment has been modified.</p> <p>e. Maintain a permanent record of the protective mask lot number and the filter element lot number. Prepare DD Form 314, Preventive Maintenance Schedule and Record, for mask or group of masks.</p> <p>f. Put mask back in carrier.</p>	

**2-6. IDENTIFYING AN INDIVIDUAL'S MASK.**

a. Although a mask will be used only by the soldier to whom it is issued and fitted, do not make permanent identification marking on either mask or carrier (AR 700-84). Attach a removable tape or a tag to the carrier. The tape or the tag may be marked with the soldier's name or a code number for identification purposes. The date the mask was tested and fitted to the soldier may be used as part of the identification code.

b. Each unit will devise its own code. Take care not to include any designations that may identify the parent organization. The code should not be similar to the code of a neighboring unit.

**Section III. EQUIPMENT/USER FITTING INSTRUCTIONS**

**2-7. GENERAL.**

Initial facepiece fitting should be performed by the unit NBC NCO or other trained personnel. This section provides instructions for use of mask sizing tool and for adjusting facepiece to the soldier at initial fitting.

**2-8. USE OF MASK SIZING TOOL.**

This task covers:	
a. Locating Reference Markings	c. Measuring Face Width
b. Measuring Face Length	

<p><b>INITIAL SETUP</b></p> <p><i>Materials/Parts</i></p> <ul style="list-style-type: none"> <li>Camouflage face paint (item 17, app D)</li> <li>Disposable applicator (item 1, app D)</li> <li>Outside caliper (item 8, app D)</li> </ul>
--

a. *Locating Reference Markings.*

1	WARNINGS
	<p>To ensure correct fit, do not measure soldier for mask if he has a facial sore, wound, or facial swelling. Postpone the fitting until the condition has healed.</p> <p>To ensure correct fit, male soldiers shall be clean shaven, i.e., no beards or large sideburns.</p> <p>Be sure soldier's eyes are closed and completely covered by his hands to avoid eye injury.</p> <p>To ensure correct fit, make sure soldier removes glasses, if worn, and does not shift or squeeze flesh around eyes or nose.</p>

## 2-8. USE OF MASK SIZING TOOL (CONT).

### a. Locating Reference Markings (Cont).

# 2

- a. Ask soldier to be seated and instruct him to close his eyes and cover them with his hands.
- b. If applicator is used, dip the wooden/plastic end of the applicator into the white end of the tube of camouflage paint and pick up a very small amount of paint.
- c. Locate the joint between the bridge of the nose and the forehead by feeling the depression above the bridge of the nose with your fingertip. Keep finger in place as a guide during reference marking.
- d. Touch the paint-tipped end of the applicator (1) to the center of the nose depression to mark a very small dot.



# 3

- a. Locate the groove or depression at the bottom of the chin bone with your thumb or finger. Keep thumb or finger in place as a guide.
- b. Use the paint-tipped end of applicator (1) to mark a very small dot at the bottom of the chin depression.

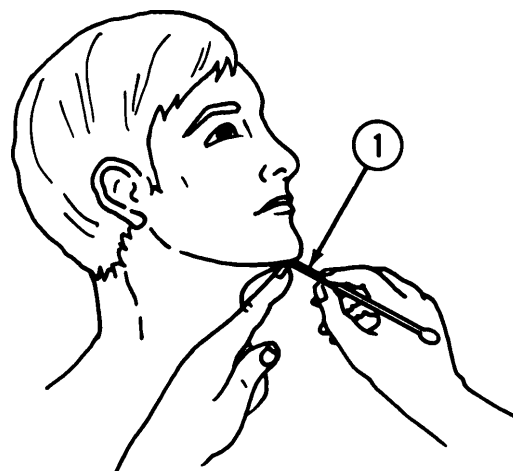

b. *Measuring Face Length.***1**

- a. To open the ends of the caliper (1), turn the adjustment nut (2).
- b. Place the laminated measuring scale, located at back of manual, on a flat surface.

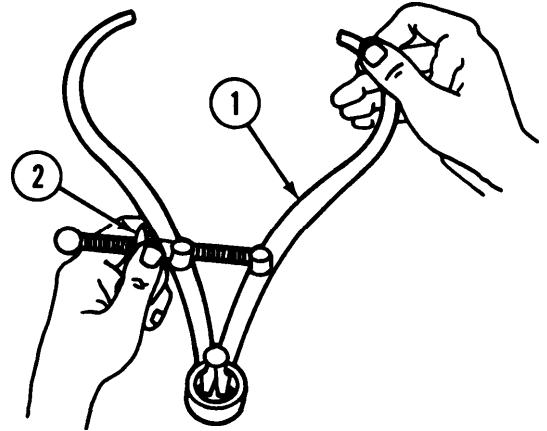
**2**

Initial Measurement.

**NOTE**

Care must be taken to measure on the scale correctly. After caliper is set on the scale, do not change the caliper adjustment until after soldier is measured.

- (1) Place one end of the caliper on line A (left edge) of the A-B measuring scale. Hold the caliper steady.
- (2) Carefully tighten/loosen the adjustment nut on the caliper to place the other end of the caliper on line B of the scale. This sets the A-B scale measurement.

**3****WARNINGS**

To ensure correct fit, do not shift or squeeze flesh around eyes or nose.

The ends of the measuring caliper are sharp. Be sure soldier's eyes are closed and covered by his hands to avoid eye injury.

Care must be taken when using the caliper around the soldier's face. Keep the caliper away from his eyes.

Soldier must remain very still while facial length and width measurements are being made.

To prevent injury to the soldier or incorrect measurements, do not be distracted by conversation, noise, or actions of others while taking measurements.

**4**

- a. Place one end of the caliper on the dot under the soldier's chin and hold the end in place.
- b. Using the other hand, place the other end of the caliper on soldier's nose and hold the end in place.

**NOTE**

When the measurement is too close to decide whether mask required by soldier is large or medium, measure the soldier for the next smaller size. The measurement must be very precise.

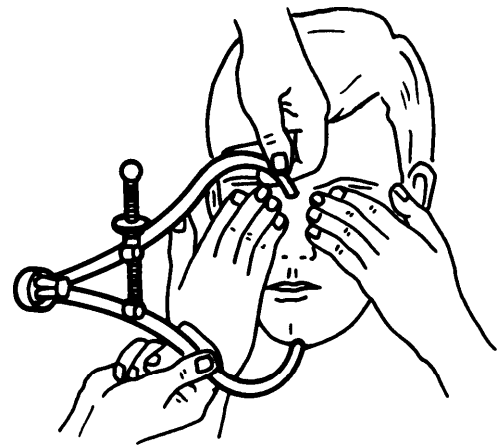



---

## 2-8. USE OF MASK SIZING TOOL (CONT).

---

*b. Measuring Face Length (Cont).*

### 5

- a. Give soldier a LARGE size mask if the caliper end contacts the nose anywhere below the center of the dot on the nose. Proceed to paragraph 2-9 to complete the fitting and adjusting procedures. Proceed to paragraph 2-12 to check for leaks.

**NOTE**

Fitting is not complete until procedures on paragraphs 2-9 and 2-12 have been completed.

- b. Go to the next step if the caliper end contacts the nose anywhere above or on the center of the dot.

### 6

- a. To measure for MEDIUM size mask, perform the steps below.

**WARNING**

To ensure correct fit, care must be taken to measure on the scale correctly. After caliper is set on the scale, do not change the caliper adjustment until after the measurement is made on the soldier.

- b. Place one end of the caliper on line A (left edge) of the A-C measuring scale.
- c. Tighten the adjustment nut on the caliper to place the other end of the caliper on line C. This sets the A-C measurement.
- d. With the scale measurement set on the calipers, repeat steps 3 and 4 on page 2-5.
- e. The soldier requires a MEDIUM size mask if the caliper end contacts the nose anywhere below the center of the dot on the nose. Proceed to paragraph 2-9 to complete the fitting and adjusting procedures. Proceed to paragraph 2-12 to check for leaks.

**NOTE**

Fitting is not complete until procedures in paragraphs 2-9 and 2-12 have been completed.

- f. Go to MEASURING FACE WIDTH if the caliper end contacts the nose anywhere above or on the center of the dot.

*c. Measuring Face Width.*

### 1

- a. To open the ends of the caliper, turn the adjusting nut.
- b. Make certain the measuring scale located at back of manual is on a flat surface.

## 2 Initial Measurement.

### NOTE

Care must be taken to measure on the scale correctly. After caliper is set on the scale, do not change the caliper adjustment until after the measurement is made on the soldier.

- (1) Place one end of the caliper on line D (left edge) of the D-E measuring scale.
- (2) Tighten/loosen adjustment nut on the caliper to place the other end of the caliper on line E of the scale. This will set the D-E scale measurement.
- (3) Look at the soldier full face (center front). Observe where the widest part of the face is in the cheekbone area.

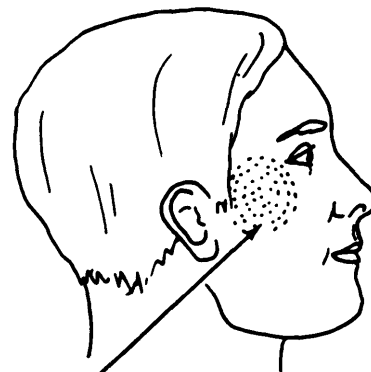

AREA FOR FACE  
WIDTH MEASUREMENT

## 3

### WARNINGS

Care must be taken when using the caliper around the soldier's face. Ends of the caliper are sharp. Keep the caliper away from the soldier's eyes.

Soldier's eyes must be closed and completely covered by his hands during measurements to avoid eye injury.

Soldier must remain very still while facial length and width measurements are being made.

To prevent injury to the soldier or incorrect measurements, do not be distracted by conversation, noise, or actions of others while taking measurements.

## 4

- a. Try to span the face with the caliper, and place each end at the widest point in the cheekbone area.
- b. The soldier requires a SMALL size mask if the caliper does not fit over the widest part of the face. Proceed to paragraph 2-9 to complete the fitting and adjusting procedures. Proceed to paragraph 2-12 to check for leaks.

### NOTE

Fitting is not complete until procedures in paragraphs 2-9 and 2-12 have been completed.

- c. The soldier requires an EXTRA SMALL size mask if the caliper fits over the widest part of the face. Proceed to paragraph 2-9 to complete the fitting and adjusting procedures. Proceed to paragraph 2-12 to check for leaks.

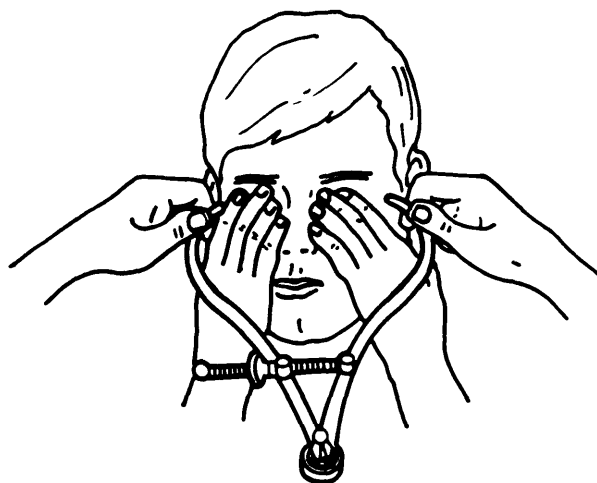

### NOTE

When the measurement is too close to decide whether mask required by soldier is small or extra small, the soldier should be given the extra small size. The measurement must be very precise.

## 2-9. ADJUSTING FACEPIECE AT INITIAL FITTING.

This task covers:

- a. Putting on Facepiece
- b. Adjusting Facepiece

c. Checking for Fit

a. *Putting on Facepiece.*

# 1

### WARNINGS

Before putting on and adjusting facepiece female soldiers shall remove all hairpins, combs, hair knots, buns, or braids that will interfere with facepiece seal. Male soldiers must be clean shaven to prevent facepiece leaks.

In order to ensure proper respiratory protection and safety, initial mask fitting must be performed by a trained unit NBC NCO or another trained person during issue of the mask.

### NOTE

See paragraph 2-8 for instructions to use the mask sizing tool. Follow these procedures BEFORE "Adjusting Facepiece at Initial Fitting."

Ask soldier to be seated.

# 2

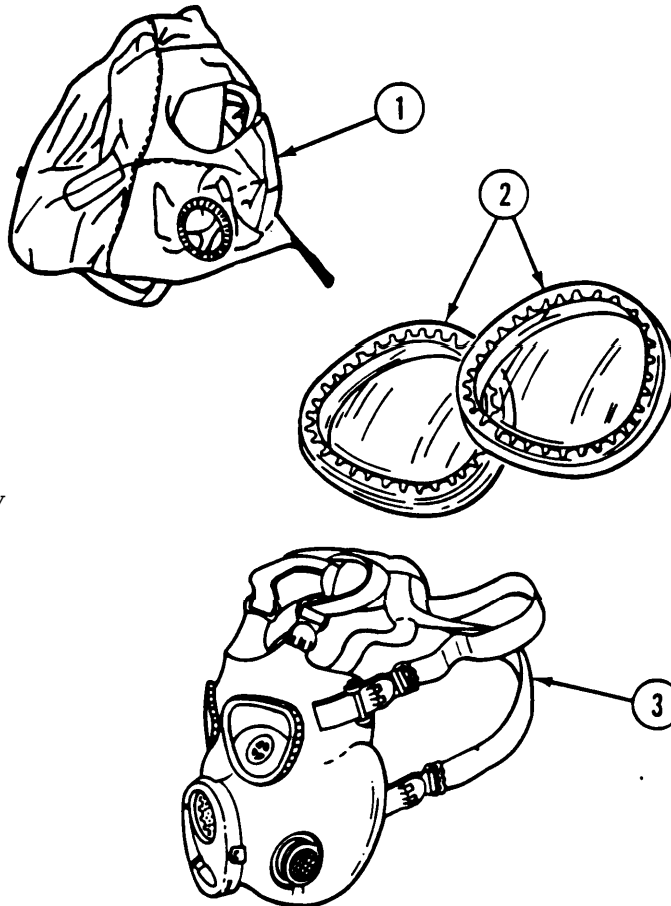

a. Remove hood (1) and eye lens outserts (2) and place in carrier.

b. Loosen straps of head harness (3) so that end clips are approximately 1 inch (2.5 cm) from clip and buckle assemblies.

### 3

- a. Open facepiece assembly (4) with thumbs under head harness.
- b. Put chin in chin pocket.
- c. Pull head harness (3) over head while pushing hair away from forehead. While doing this, use other hand to push facepiece on face and hold in place.

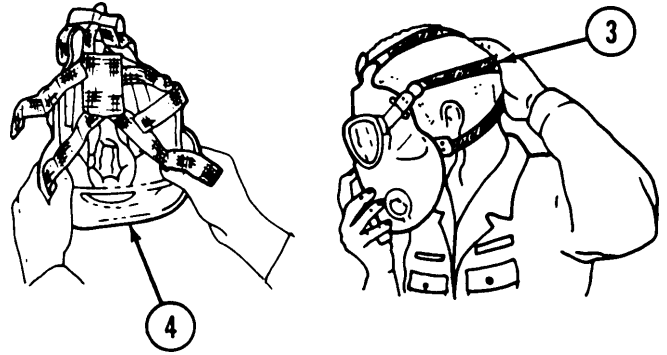

b. *Adjusting Facepiece.*

### 1

- a. Hold facepiece assembly tightly against chin. Make sure outlet valve is not covered.
- b. *NBC NCO.* Center pad (1) of head harness (2) on back of soldier's head and have him hold in place.

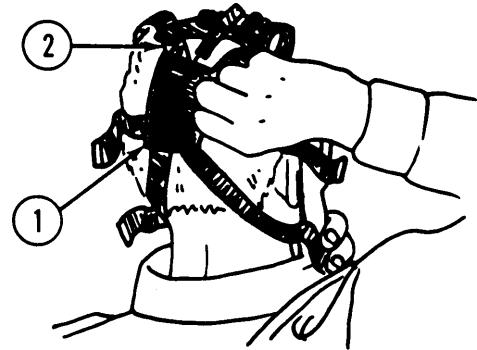

### 2

- a. *NBC NCO.* Place finger or thumb under clip and buckle assembly (3) of forehead strap (4). Then give strap end a sharp tug until clip and buckle assembly (3) feels snug. Adjust other forehead strap in same manner.
- b. *NBC NCO.* Place finger or thumb under clip and buckle assembly (3) of cheek strap (5), and adjust cheek strap until it feels snug. Adjust other cheek strap in same way.
- c. *NBC NCO.* Have soldier release facepiece. Facepiece should not slip down. If facepiece slips, readjust forehead straps (4) and cheek straps (5) until facepiece remains in place.

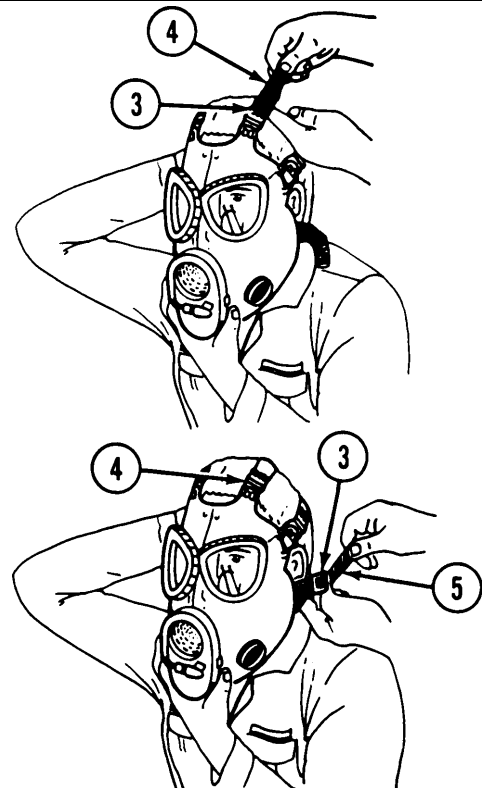

**2-9. ADJUSTING FACEPIECE AT INITIAL FITTING (CONT).**

b. *Adjusting Facepiece (Cont).*

**3**

- a. *NBC NCO.* Place finger or thumb under clip and buckle assembly (3) of temple strap (6), and adjust temple strap until clip and buckle assembly (3) feels snug against finger. Repeat adjustment on other temple strap.
- b. *NBC NCO.* Place palms lightly over inlet valve and have soldier breathe in until facepiece collapses. Soldier should hold breath for 10 seconds.



c. *Checking for Fit.*

**1**

*NBC NCO.* With soldier standing, check for proper fit according to following order of importance.

- (1) Edge of facepiece does not come into hairline at forehead or temple.
- (2) Temple straps (1) and cheek straps (2) do not cut into ears.
- (3) Eye pupils are within 1/2 inch (1.3 cm) of center of facepiece eyelens (3).
- (4) Facepiece does not press flesh so tightly that eyes are partly closed.

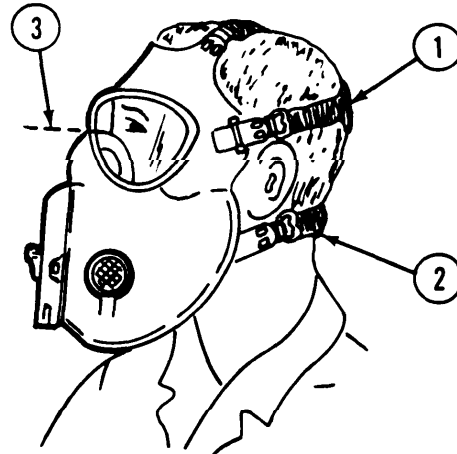

**2**

Continue to check for fit in the following order. Make sure soldier is standing.

- (1) Nosecup assembly (4) does not obscure vision or press into nose.
- (2) Bottom of facepiece does not cut into throat.
- (3) Skin in front of ear is not wrinkled. If wrinkled, release by lifting sides of facepiece off face.

**NOTE**

If facepiece is difficult to fit, try another size. A smaller size facepiece usually seals better than a larger size.

**FOLLOW-ON-MAINTENANCE:** Check the mask for leaks (para 2-12).

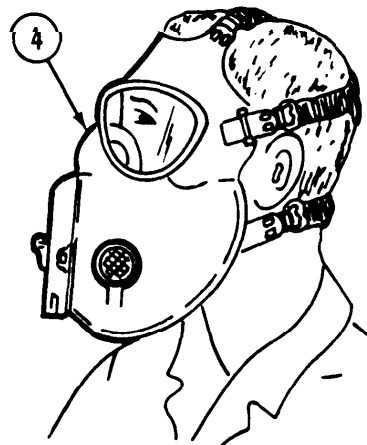

## Section IV. PREVENTIVE MAINTENANCE CHECKS AND SERVICES (PMCS)

### 2-10. PREVENTIVE MAINTENANCE CHECKS AND SERVICES.

a. *General.* Perform unit PMCS on the M17, M17A1 and M17A2 mask semiannually (every 6 months). The operator may perform semiannual PMCS under supervision of unit maintenance personnel or in accordance with unit SOP. Semi-annual PMCS will be scheduled on DD Form 314, Preventive Maintenance Schedule and Record.

b. *PMCS Procedures.* This PMCS table lists those required checks and services to be done to be sure the masks are in condition to safely perform their mission. The inspections listed apply to all three masks unless an exception is specifically noted.

c. *Explanation of Columns on the PMCS Schedule.*

(1) *Item Number Column.* Checks and services are numbered in order of performance. Use this

column as a source of item numbers for the TM Number Column on DA Form 2404, Equipment Inspection and Maintenance Worksheet, in recording results of PMCS.

(2) *Item To Be Inspected Column.* The items listed in this column are divided into groups indicating the portion of the equipment of which they are part. The common name or official nomenclature as shown on the maintenance allocation chart (app B) is used for this purpose.

(3) *Procedures Column.* This column briefly describes the procedure for performing the check or service. Whenever replacement or repair is recommended, reference is made to paragraph number for the applicable maintenance instruction.

UNIT PREVENTIVE MAINTENANCE CHECKS AND SERVICES SEMIANNUAL SCHEDULE (PMCS)\*

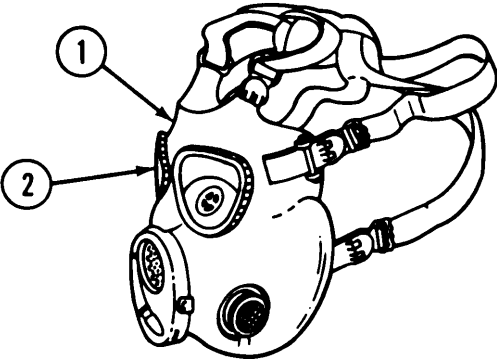
Item No.	ITEM TO BE INSPECTED	PROCEDURES
1	<i>Facepiece Assembly.</i>	<p>a. Visually inspect outside and inside surfaces for dirt, mud, and greasy or oily substances. (See para 2-16 for cleaning.)</p> <p>b. Check facepiece (1) for permanent set which may affect fit of facepiece. Signs of permanent set are:</p> <p>(1) Facepiece (1) is difficult to spread open</p> <p>(2) Unusual or too much stiffness in sealing area of facepiece (1).</p> <p>c. Check facepiece (1) for holes, tears, splits, soft or sticky spots by holding in front of a light source.</p> <p>d. Check rubber next to eyelenses (2) to be sure neither eyelens will pull away from facepiece (1).</p> <p style="text-align: center;"><b>NOTE</b></p> <p style="text-align: center;">Dry rot in head harness tabs is not cause for rejection if pull check is withstood.</p> <div style="text-align: center;">  </div> <p>REPLACE MASK IF FACEPIECE EXHIBITS ANY DEFECTS LISTED IN STEPS a THROUGH f.</p>

\*Weekly in combat situations

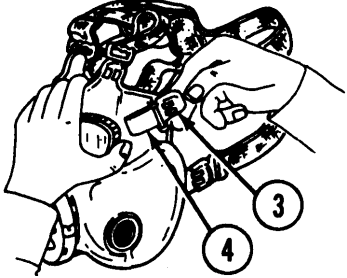
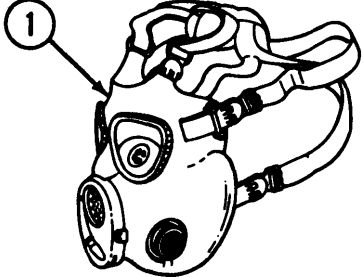
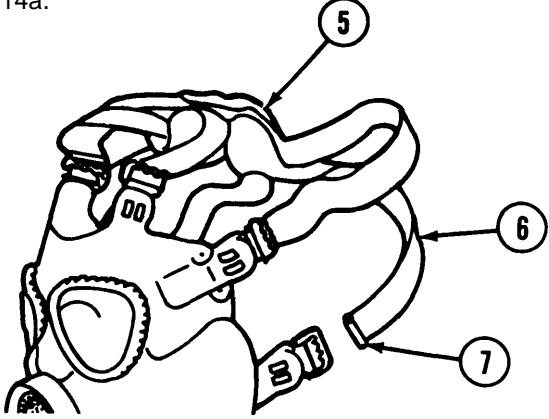

Item No.	ITEM TO BE INSPECTED	PROCEDURES
2	Head Harness.	<p>e. Check for dry rot in head harness tabs. Hold facepiece as illustrated. Grasp metal dip and buckle assembly (3) and inside flange of rubber tab (4) between thumb and forefinger. Pull on rubber tab (4) until it extends 1/2 in. to 3/4 in. (1.3 cm to 1.9 cm) from normal position.</p>  <p>f. Check rest of facepiece (1) for stiff areas which crumble when rubbed between fingers and exhibit cracks which expand when rubber is stretched.</p>  <p>a. Check head harness (5) for loss of elasticity.</p> <p>b. Check for dirt. Check straps (6) for cuts, tears, missing metal clip ends (7), or deterioration such as mildewing or fraying. For replacement see para. 2-14a.</p> 

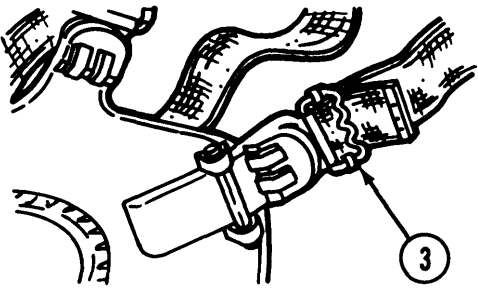
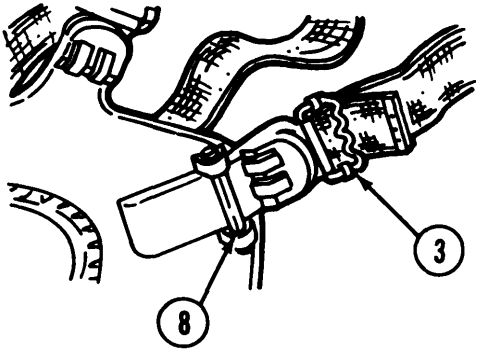

UNIT PREVENTIVE MAINTENANCE CHECKS AND SERVICES SEMIANNUAL SCHEDULE (PMCS)\*

Item No.	ITEM TO BE INSPECTED	PROCEDURES
3	Clip and Buckle Assembly.	<p style="text-align: center;"><b>CAUTION</b></p> <p>Over a period of time, copper poisoning migrating into the facepiece from a clip and buckle assembly will make entire facepiece unserviceable.</p> <ol style="list-style-type: none"> <li>a. Make sure finish (lacquer) on clip and buckle assembly (3) covers all clip and buckle assembly surfaces in contact with the rubber.</li> <li>b. Check for missing or broken clip and buckle assemblies (3). For replacement see para 2-14b.</li> </ol> 
4	Temple Pin.	<p>Check for broken or missing temple pins (8). For replacement see para 2-14c.</p> 

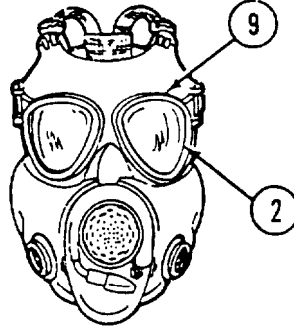
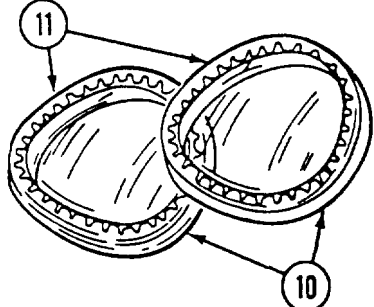
\*Weekly in combat situations.

Item No.	ITEM TO BE INSPECTED	PROCEDURES
5	Eyelenses, Eyerings, and Eyelens Outserts.	<p>a. Check eyelenses (2) for cracks, cuts, scratches, or discoloration that affects vision. If replacement is necessary send to depot.</p> <p>b. Check eyerings (9) for distortion or corrosion. If replacement is necessary send to depot.</p>  <p>c. Check eyelens outserts (10) for cracks, chips, or discoloration that affects soldier's vision. Check rubber rings (11) for tears, looseness, brittle spots, soft or sticky spots, or cracked rims. Replace if necessary.</p>  <p><b>WARNING</b> Do not use facepiece if outlet valve disk is missing or damaged. The facepiece will leak.</p> 
6	Voicemitter-Outlet Valve Assembly and Voicemitter-Outlet Valve Assembly Cover	

UNIT PREVENTIVE MAINTENANCE CHECKS AND SERVICES SEMIANNUAL SCHEDULE (PMCS)\*

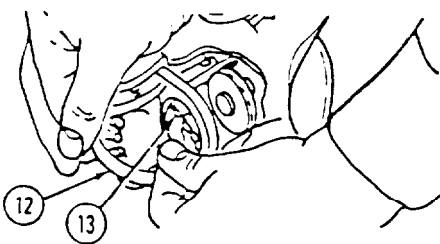
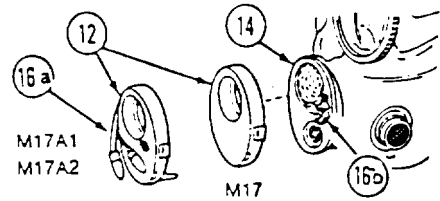
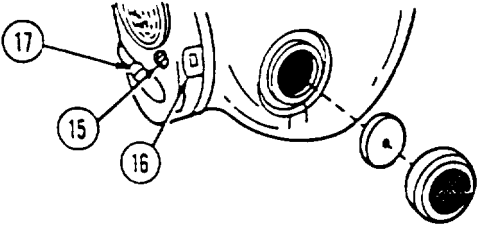
Item No.	ITEM TO BE INSPECTED	PROCEDURES
6	Voicemitter-Outlet Valve Assembly and Voicemitter-Outlet Valve Assembly Cover (Cont).	<p>a. Remove cover (12) and check that outlet valve disk (13) is present and is not dusty, dirty, or wet. Carefully remove any dust, dirt, or debris with a damp lint-free cheesecloth (item 10, app D). Remove excess moisture with a dry cheesecloth.</p> <p style="text-align: center;"><b>CAUTION</b></p> <p style="text-align: center;">Do not overly stretch the outlet valve disks or they will tear</p> <p>b. Examine outlet valve disk (13) for dirt, creases, spots, or indentations. If they appear, carefully remove outlet valve disks (13) and very carefully stretch the disks no more than 1/8 inch. Visually inspect the disks against a light source for punctures. Rotate outlet valve disk (13) to make sure it is not sticking. For replacement see para 2-14g.</p>  <p>c. Check outlet valve seat (14) for dirt. Clean if necessary.</p> <p>d. Check cover (12) for cuts, tears, or holes. For replacement see para 2-14e.</p>  <p>e. Inspect voicemitter-outlet valve assembly for missing cover studs (15) or bent crimping ring (16). Check drink tube (16a) for holes and drinking lever (16b) for distortion damage. For replacement send to depot.</p> <p>f. Inspect M17A1/M17A2 for damaged or missing quick disconnect coupling half (17). Check coupling half (17) for clogged opening. For cleaning see para 2-16b3. For replacement see para 2-14e.</p> 

\*Weekly in combat situations.

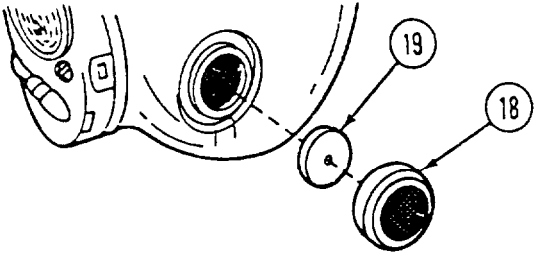
Item No.	ITEM TO BE INSPECTED	PROCEDURES
7	Inlet Valve Assemblies.	<p style="text-align: center;"><b>WARNING</b></p> <p>Do not use facepiece if inlet valve assemblies or inlet valve disks are missing. Facepiece may leak.</p> <ol style="list-style-type: none"> <li>a. Check that inlet valve assemblies (16) are in place.</li> <li>b. Remove inlet valve assemblies (16) and check that inlet valve disks (19) are present and mesh is not worn or torn.</li> <li>c. Rotate inlet valve disks (19) to make sure they are not stuck and are seated properly.</li> <li>d. Check for curled, discolored, or dirty inlet valve disks (19).</li> </ol> <p style="text-align: center;"><b>CAUTION</b></p> <p>Do not overly stretch the inlet valve disks or they will tear.</p> <ol style="list-style-type: none"> <li>e. Examine inlet valve disks (19) for dirt, creases, spots, or indentations. If they appear, carefully remove inlet valve disks (19), and very carefully stretch the disks no more than 1/8 inch. Visually inspect the disks against a light source for punctures. For replacement see para 2-15.</li> </ol> <p style="text-align: center;"><b>NOTE</b></p> <p>The word TOP may be missing or incorrectly positioned. Exact top may be marked with a white dot.</p> <ol style="list-style-type: none"> <li>1. Check that both inlet valve assemblies (16) are installed with the word TOP, or white dot, on the rim of the inlet valve at the top and with the louvers horizontal and slanted downward when the facepiece is in the as-worn position.</li> </ol> <div style="text-align: center;">  <p>The diagram illustrates the components of the inlet valve assembly. It shows a side view of the facepiece with two inlet valve assemblies (16) mounted on the sides. Below the facepiece, two inlet valve disks (19) are shown. One disk is shown in its seated position, and the other is shown being stretched. Callout 18 points to the rim of the inlet valve assembly, and callout 19 points to the inlet valve disk.</p> </div>

UNIT PREVENTIVE MAINTENANCE CHECKS AND SERVICES SEMIANNUAL SCHEDULE (PMCS)\*

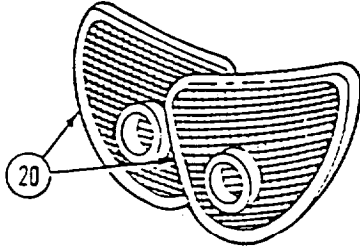
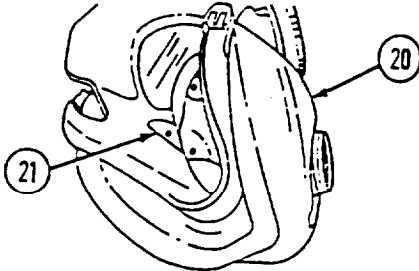
Item No.	ITEM TO BE INSPECTED	PROCEDURES
8	Filter Elements.	<p style="text-align: center;"><b>WARNING</b></p> <p>Dirt or other foreign material on the connectors of filter elements (20), mating surfaces of the facepiece, or trapped between these surfaces lets contaminated air into mask.</p> <p>DO NOT throw away damaged or unusable filters as ordinary trash.</p> <p>DO turn in damaged or unusable filters to your hazardous waste management office or Defense Reutilization and Marketing Office (DRMO).</p> <p>a. Remove filter elements (20) and check for loose connectors and torn mesh screening. Check that filter elements are a matched set. (The lot numbers must be the same on both filter elements. The air flow resistance ratings must not differ by more than <math>\pm 5</math> millimeters. Both the lot number and resistance ratings are marked on the edge of the filter elements.) Check connector surfaces of filter elements. For replacement see para 2-14h.</p> <div style="text-align: center;">  </div> <p style="text-align: center;"><b>NOTE</b></p> <p>Flap buttons may be lubricated by moistening with water to ease buttoning.</p> <p>b. Check that filter elements (20) are properly installed and that pouch flaps (21) are buttoned.</p> <p>c. Put on mask. Check for excessive resistance to breathing. Filter elements (20) may be clogged with dust.</p> <div style="text-align: center;">  </div>

\*Weekly in combat situations.

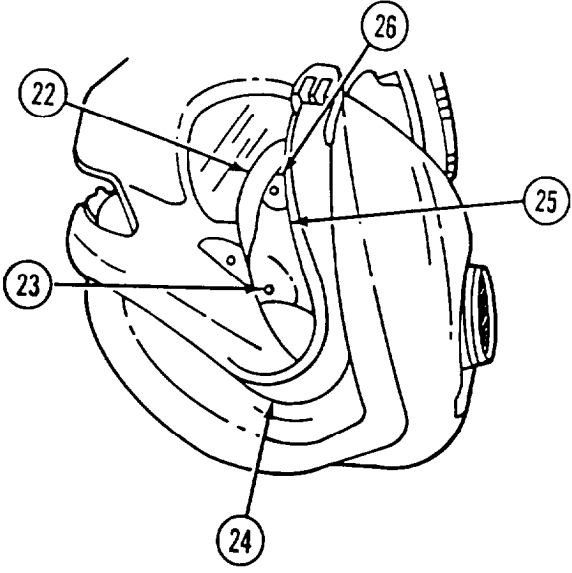
Item No.	ITEM TO BE INSPECTED	PROCEDURES
9	Nosecup Assembly.	<p>a. Check that nosecup assembly (22) is buttoned over long flap buttons (23). Check for torn buttonholes or missing buttons. Make sure chin portion of nosecup assembly lies over chin stop (24). For replacement of long or short flap buttons see para 2-14d.</p> <p>b. Check nosecup assembly (22) and nosecup valve seats (25) for dirt. Clean if necessary.</p> <p>c. Check that nosecup assembly (22) is not pulled away from voicemitter-outlet valve assembly.</p> <p>d. Check that nosecup valve disks (26) are present, Rotate valve disks to be sure they are not stuck, and check that valve disks are not curled, discolored, or dirty.</p> <p style="text-align: center;"><b>CAUTION</b> Do not overly stretch the valve disks or they will tear.</p> <p>e. Examine nosecup valve disks (26) for dirt, creases, spots, or indentations. If they appear, carefully remove nosecup valve disks (26) and very carefully stretch the disks no more than 1/8 inch. Visually inspect the disks against a light source for punctures. For replacement see para 2-14f.</p> <div style="text-align: center;">  </div>

**UNIT PREVENTIVE MAINTENANCE CHECKS AND SERVICES SEMIANNUAL SCHEDULED (PMCS)\***

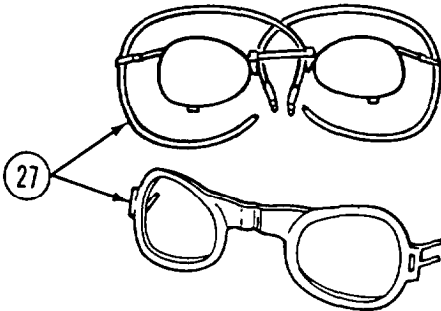
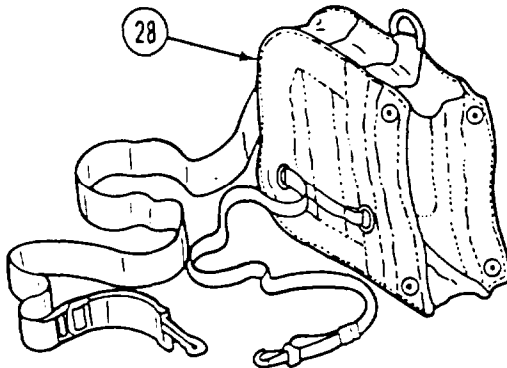
Item No.	ITEM TO BE INSPECTED	PROCEDURES
10	Optical Inserts.	<p>Inspect optical inserts (27), if issued, for broken lens, frame, or pins disconnected from facepiece.</p> 
11	Carrier	<p>a. Empty carrier (28) and check for dirt, sharp edges, torn straps, or missing hardware or torn fabric.</p> <p>b. Visually check for mildew or oily substances on carrier (28).</p> <p>c. Check that no pen or pencil markings are on the carrier except those changing the size or model number to reflect true description of mask inside.</p> 

\*Weekly in combat situations.

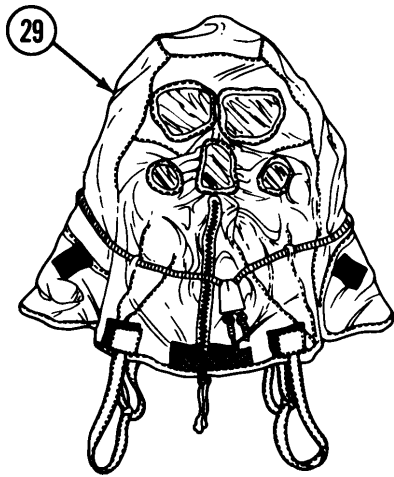
Item No.	ITEM TO BE INSPECTED	PROCEDURES
12	ABC - M6A2 Hood.	<p style="text-align: center;"><b>NOTE</b> Needle holes at the seams are acceptable.</p> <p>Examine hood (29) for</p> <ul style="list-style-type: none"> <li>a Cuts, holes or tears (do not hold in front of a light source).</li> <li>b. Sticky or gummy area.</li> <li>c. Peeled or worn coating.</li> <li>d. Straps, cord, or hardware missing, frayed, or torn.</li> <li>e. Zipper torn, broken, or inoperative.</li> </ul> <p style="text-align: center;"><b>NOTE</b></p> <p>Hoods that are unserviceable for combat or for toxic agent protection may be used for training purposes, provided the training does not involve the use of toxic agents. These hoods must be identified for training use only, so that they will not be used in combat. Identification for training use only will be according to local SOP. If hood unserviceable, notify operator to get a new hood.</p> <div style="text-align: center;">  <p>The diagram shows a top-down view of an M6A2 hood. It features a central zipper, two large circular eye lenses, and two smaller circular filters. A callout circle containing the number '29' has an arrow pointing to the top edge of the hood's opening.</p> </div>

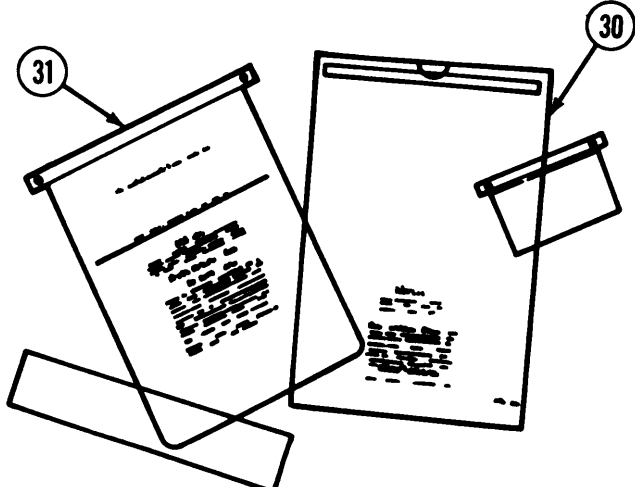
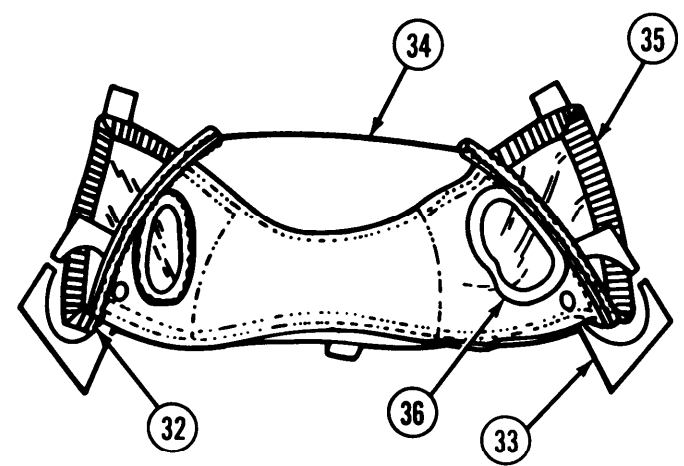

UNIT PREVENT MAINTENANCE CHECKS AND SERVICES SEMIANNUAL SCHEDULED (PMCS)\*

Item No.	ITEM TO BE INSPECTED	PROCEDURES
13	<i>M1 Waterproof Bag.</i>	Check M1 waterproof bag (30) for cracks, tears, holes, and brittleness.
14	<i>M1A1 Waterproof Bag.**</i>	<p>Check M1A1 waterproof bag (31) for cracks, tears, holes, and brittleness.</p> 
15	<i>M4 Winterization Kit.</i>	<p>Check prefilter (32) for dirt or tears. Check retainers (33) for cracks. Check that tape (34) is secured at top of winterization kit. Check that cheek flaps (35) will secure over inlet valve openings (36).</p> 

\*Weekly in combat situations.

\*\*May be authorized.

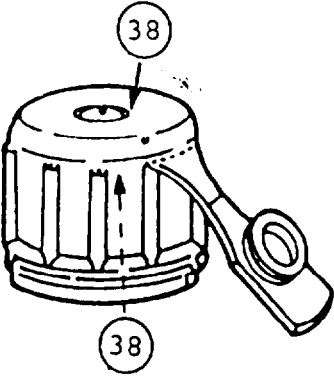
Item No.	ITEM TO BE INSPECTED	PROCEDURES
16	Canteen and M1 Cap	<p>a. Inspect canteen body (37) for cracks or holes</p> <p>b. Inspect canteen neck lip or cap mating surfaces (38) for cracks, chips, or deformities</p>  <p>c. Inspect M1 cap's mating surfaces (38) with the canteen and quick-disconnect coupling for dirt, rust deformity, cracks, or chips.</p> 



**2-11. FILTER ELEMENT REPLACEMENT CRITERIA.**

**WARNING**

When changing contaminated filter elements, wear protective mask and clothing according to your unit SOP.

**NOTE**

Install only matched sets of the same lot number. Filter elements are marked either right or left and must be identically matched by the lot number embossed on the filter element's edge along with color matched connectors. Resistance must be within 5 mm of water as marked on the edge of filter elements.

a. Combat zone, rapid deployment assignment (24 hours or less), and special mission (e.g., explosive ordnance disposal, technical escort, chemical or nuclear accident response teams, surety sites) units replace filter elements if one or more of the following conditions exist:

(1) See the following table for peacetime filter element replacement intervals, by climate, for the above type units only.

- (2) Filter elements have been immersed in water.
- (3) Filter elements have splits or cuts in filter or edge seal, or a bent or split connector.
- (4) Filter elements have been crushed.
- (5) The operator feels excessive resistance to breathing, and inspection shows that the filter elements are dogged.
- (6) The filter element has been reported as unserviceable in SB 3-30-2.
- (7) Unit Commander directs replacement of filter elements.
- (8) Every 30 days after exposure to toxic chemical operations.

b. All other units not defined in step a, replace filter elements if one or more of the following conditions exist:

- (1) Upon notification of deployment into a combat zone.
- (2) Same as step a (2) thru (7).

*M13A2 FILTER ELEMENTS - REPLACEMENT INTERVALS BY CLIMATE*

Climate	Climate Categories*	Replacement Intervals (Months)**
Tropic	1, 2, and 3	2
Temperate	4, 5, and 6	12
Arctic	7 and 8	24

\*Climate categories are defined by AR 70-38.

\*\*Filter elements that exceed these intervals remain serviceable for training only.

Section V. CHECKING FACEPIECE FOR LEAKS

2-12. CHECKING FACEPIECE FOR LEAKS.

This task covers:

a. Testing

b. Adjustment/Replacement

INITIAL SETUP

Materials/Parts

- Aspirator bulb (item 6, app D)
- Chemical and oil gloves (item 11, app D)
- Disposable applicator (item 1, app D)
- n-Amyl acetate (item 15, app D)
- Smoke tube (item 21, app D)

References

TM 34240-279-10

Equipment Condition

Mask adjusted

Personnel Required: 2

- MOS 54B Chemical operations specialist or NBC NCO
- Soldier

a. Testing.

**1**

**WARNING**

Do NOT touch your skin (or the soldier) with n-Amyl acetate (banana oil). It could irritate the skin. Wear rubber gloves if an application could wet your fingers.

Do NOT smoke around n-Amyl acetate (banana oil). Keep n-Amyl acetate (banana oil) away from an open flame. It can catch on fire.

Do NOT test masks in a closed, poorly ventilated area. Test outdoors or in a well aired room. n-Amyl acetate (banana oil) may be toxic if inhaled in quantity.

**CAUTION**

Do NOT touch mask with n-Amyl acetate (banana oil). It is a solvent and could weaken the mask.

PRELIMINARY PROCEDURE: Put on and adjust facepiece (para 2-9) before opening the bottle of n-Amyl acetate (banana oil). If soldier smells n-Amyl acetate (banana oil) just before masking, test results will be inaccurate.

**2**

a. Dip applicator in n-Amyl acetate (banana oil).

**NOTE**

Soldier should breathe deeply through nose only.

b. Keep applicator approximately 1 or 2 inches (2.5 or 5.1 cm) from mask.

c. While soldier is looking straight ahead, move applicator around outlet valve assemblies (1), voicemitter (2), inlet valve assemblies (3), eyelenses (4), and completely around outer edge of facepiece.



**3**

- a. Have soldier turn head to left and move applicator completely around outer edge.
- b. With soldiers head turned to the right, again move applicator around outer edge of facepiece.
- c. While soldier is tilting his head back and turning his head from side to side, move applicator under his chin around outer edge of facepiece.

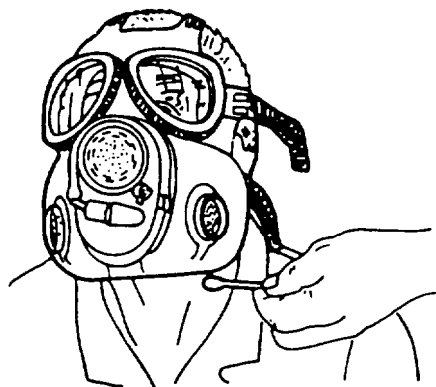
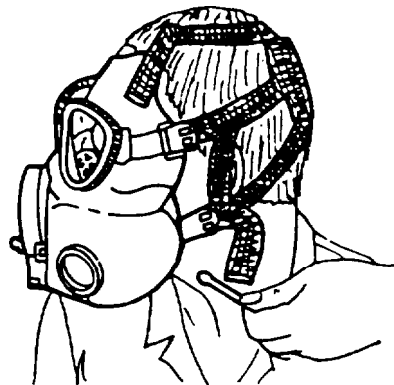

**4**

While soldier is tilting head forward touching chest with facepiece, move applicator around outer edge of facepiece.



**2-12. CHECKING FACEPIECE FOR LEAKS (CONT.)**

a. Testing (Cont).

**5**

a. Have soldier raise chin slightly off chest and shake head. Hold applicator around edge.

b. Have soldier smile and frown while applicator is being moved around edge of facepiece.

c. Instruct soldier to press his palms firmly over inlet valve assemblies, but not so firmly that facepiece assembly is distorted and loses its seal. Have soldier breathe in to create a vacuum and collapse facepiece assembly. Move applicator around eyelenses before having soldier breathe out.

d. Have soldier steady facepiece, withdraw quick disconnect coupling half (1) from pocket (2), and let it hang freely.

e. Instruct soldier to open mouth and turn lever (3) all the way toward voicemitter (4).

**WARNING**

If resistance is not felt when checking drinking system, the drinking system leaks. Do not drink, get a new mask.

f. Instruct soldier to keep lever (3) turned, hold drinking mouthpiece (5) between teeth, and blow into drinking mouthpiece (5). Soldier should feel positive pressure (resistance). If not, drinking system is defective and mask must be replaced.

g. Have soldier release drinking mouthpiece (5) and return lever (3) to vertical position.

h. Have soldier return quick disconnect coupling half (1) to pocket (2), and press tube into channel.

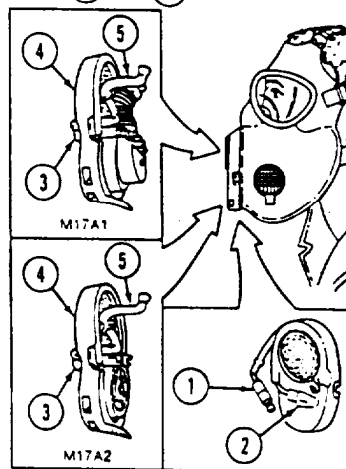
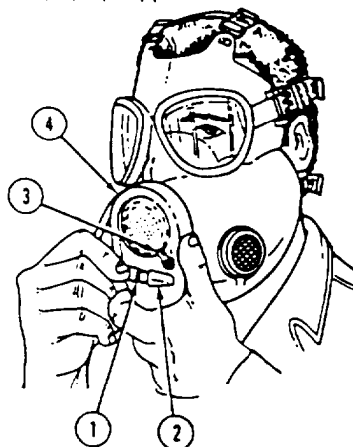

*b. Adjustment/Replacement.***1****NOTE**

After exposure to n-Amyl acetate allow a 5-7 minute waiting period for odor sensitivity to return before refitting or retesting.

- a. If soldier can smell n-Amyl acetate (banana oil), do the following:
  - (1) Check to assure head harness pad is centered correctly.
  - (2) Retighten straps after adjustment of head harness pad.
  - (3) Retest facepiece for leaks.
- b. If soldier can still smell n-Amyl acetate (banana oil), replace facepiece, and repeat test on the replacement.
- c. If soldier can still smell n-Amyl acetate (banana oil) with the second facepiece (small size) then size down one size and repeat the fitting and n-Amyl acetate test.

**2**

- a. If soldier cannot smell n-Amyl acetate (banana oil), have him unmask and smell the applicator to be sure that his sense of smell is not impaired. If the soldier's sense of smell is impaired, that facepiece must be tested in a CS (irritant) chamber or using a smoke tube and an aspirator bulb kit which produces an irritating acid smoke. Read and follow directions on the kit. The smoke tube test should be conducted in still air in an area that can be ventilated.
- b. FOLLOW-ON MAINTENANCE: Remove facepiece and store in carrier in accordance with TM 3-4240-279-10.





## Section VI. MAINTENANCE PROCEDURES

### NOTE

Do not scratch plastic eyelenses of the facepiece while performing maintenance procedures. These procedures apply to all three masks, M17, M17A1, and M17A2.

### 2-13. M17, M17A1 AND M17A2 MASK.

This task covers inspection/repair.

#### INITIAL SETUP

None required.

#### INSPECTION/REPAIR

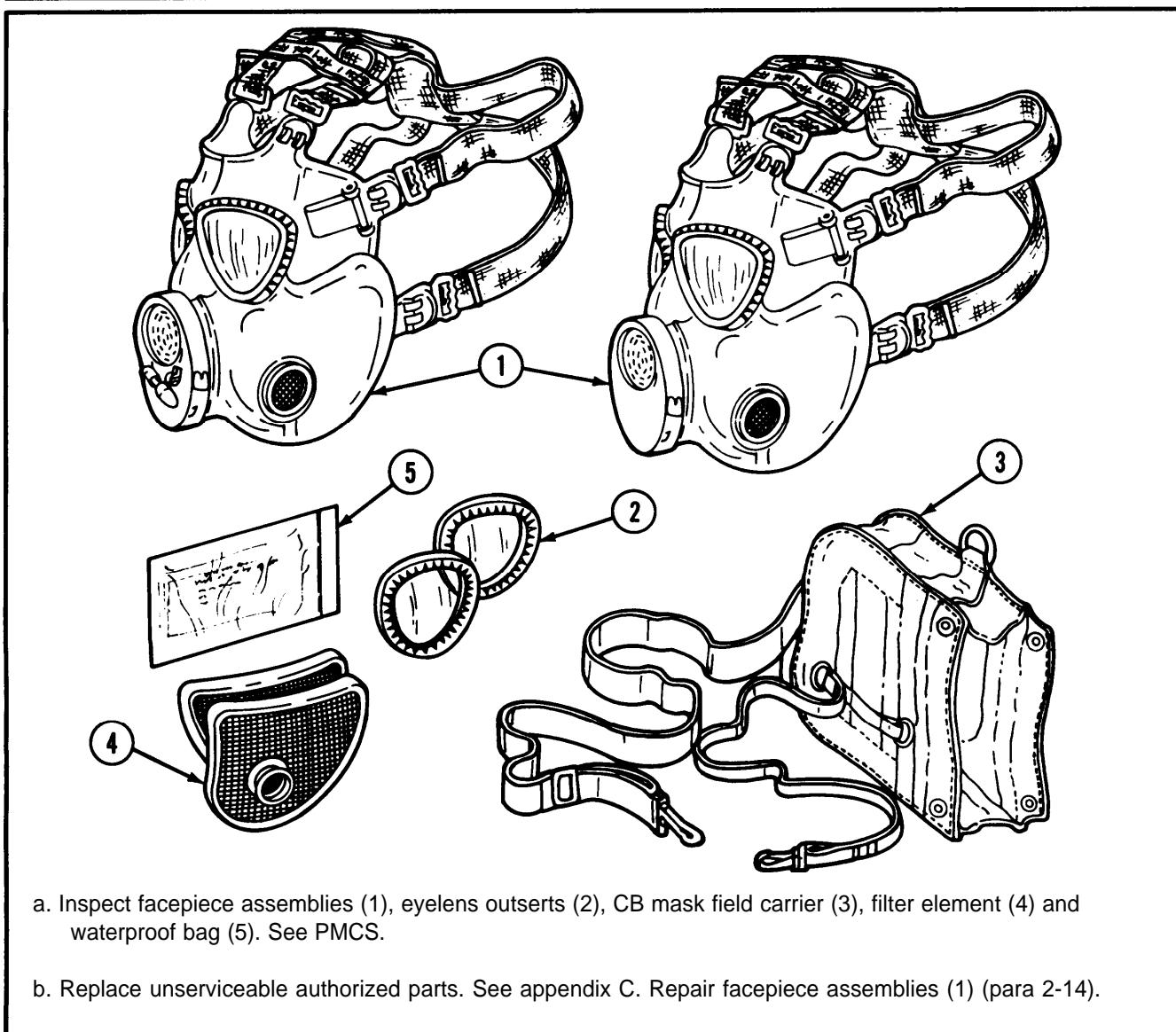

## 2-14. FACEPIECE ASSEMBLY.

This task covers repair of the:

- |   |  |
|---|--|
| <ul style="list-style-type: none"> <li>a. Head Harness</li> <li>b. Clip and Buckle Assembly</li> <li>c. Temple Pins</li> <li>d. Short and Long Flap Buttons</li> <li>e. Voicemitter-Outlet Valve Assembly Cover and Quick Disconnect Coupling Half</li> </ul> | <ul style="list-style-type: none"> <li>f. Nosecup Valve Disk</li> <li>g. Outlet Valve Disk</li> <li>h. Filter Element Set</li> </ul> |
|---|--|

### INITIAL SETUP

#### Materials/Parts

- Acid swabbing brush (item 2, app D)
- Lacquer (item 14, app D)
- Isopropyl rubbing alcohol (item 12, app D)
- Pocket knife (item 13, app D)

a. Head Harness.

### DISASSEMBLY

#### NOTE

It may be necessary to cut straps for removal.

Remove head harness (1) by working harness straps (2) out of clip and buckle assemblies (3). Remove strap end clips (4) at an angle.

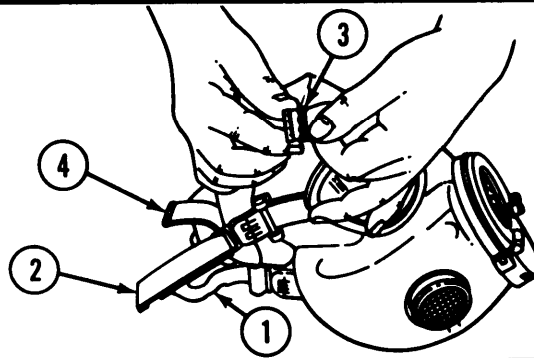

### REPAIR

Replace unserviceable authorized parts. See appendix C.

### REASSEMBLY

# 1

#### NOTE

The elastic webbing that joins the two forehead straps must be over the straps to avoid hotspots on the head.

Place head harness straps (1) next to correct clip and buckle assemblies (2).

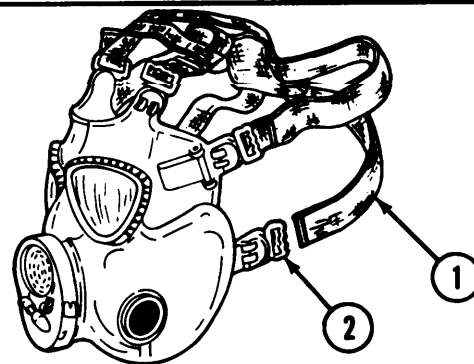

# 2

- a. Push strap end clips into clip and buckle assemblies (2) at an angle, and pull through approximately 1 inch (2.5 cm) so that strap end clips are outside.
- b. Stretch head harness (3) away from facepiece assembly (4) and check that clip and buckle assemblies (2) hold head harness straps (1) tightly.

### NOTE

**FOLLOW-ON MAINTENANCE:**  
Perform adjustment procedures (para 2-9), and check facepiece for leaks (para 2-12).

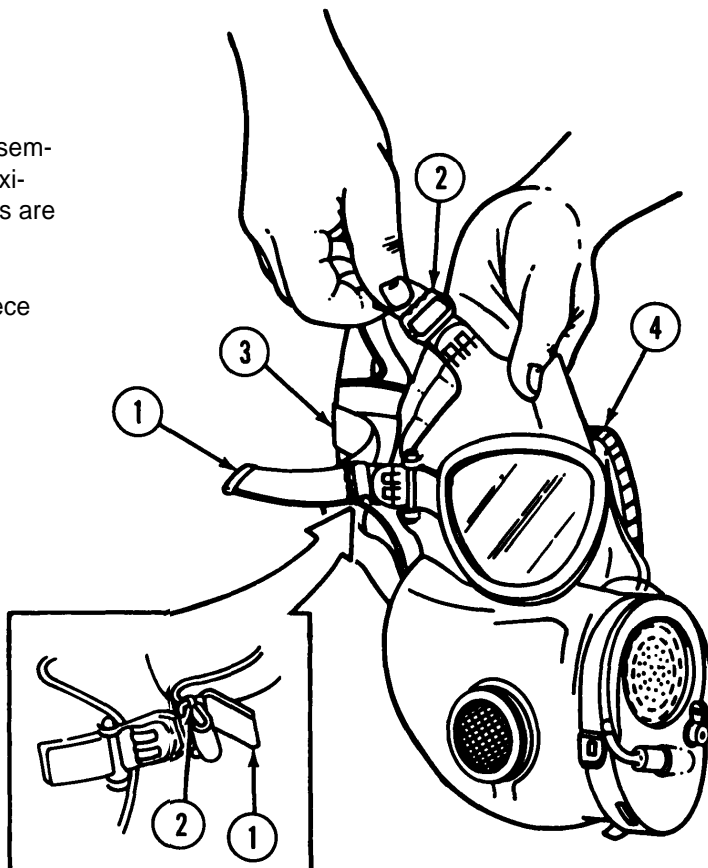

- b. *Clip and Buckle Assembly.*

## PAINTING

### CAUTION

Copper poisoning migrating into the facepiece from the clip and buckle assembly will make the entire facepiece unserviceable.

- a. Remove head harness from facepiece assembly.
- b. Paint metal surfaces that are scratched and bare with lacquer and acid swabbing brush.

## 2-14. FACEPIECE ASSEMBLY (CONT).

b. *Clip and Buckle Assembly (Cont).*

### DISASSEMBLY

Straighten clip fingers (1) of six clip and buckle assemblies (2) with blade of pocketknife. Remove and discard.

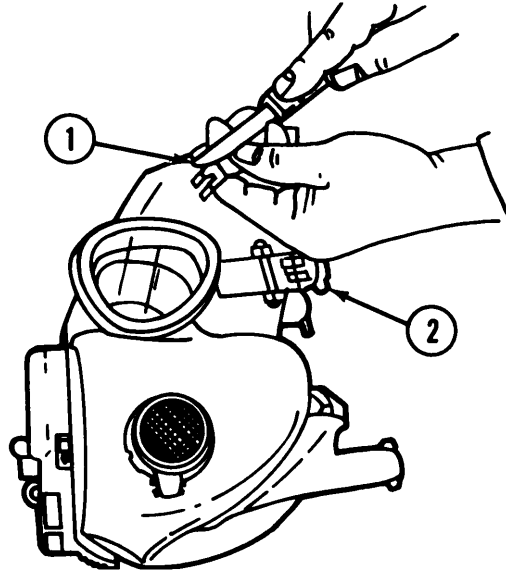

### REPAIR

Replace unserviceable authorized parts. See appendix C.

### REASSEMBLY

**1**

#### CAUTION

Be careful not to tear rubber tabs when installing clip and buckle assemblies.

#### NOTE

If tab is damaged, do not install a new dip and buckle assembly. Replace mask.

- a. Moisten dip fingers (1) of new dip and buckle assemblies (2) with water or a mixture of isopropyl alcohol and water.
- b. Press dip fingers (1) into holes molded in facepiece tabs until ends of dip fingers come through.

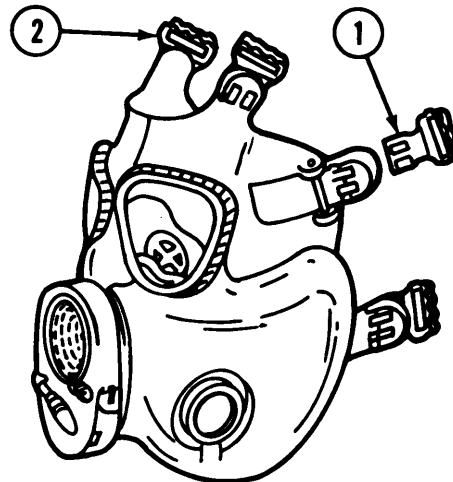

# 2

Pull back on dip and buckle assembly (2) so that dip fingers (1) fully engage tab (3) of facepiece assembly.

**NOTE**  
**FOLLOW-ON MAINTENANCE:** Install head harness (para 2-14a).

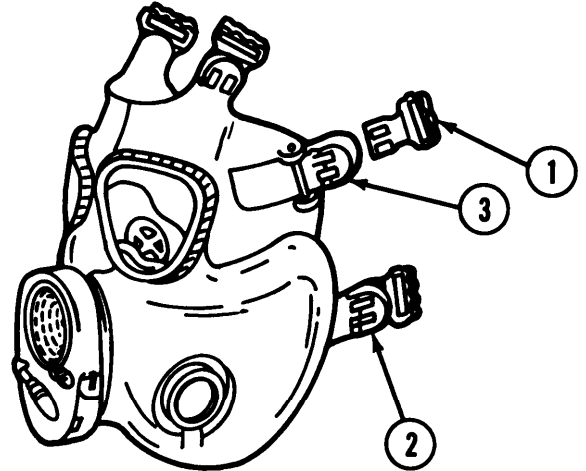

c. Temple Pins.

## DISASSEMBLY

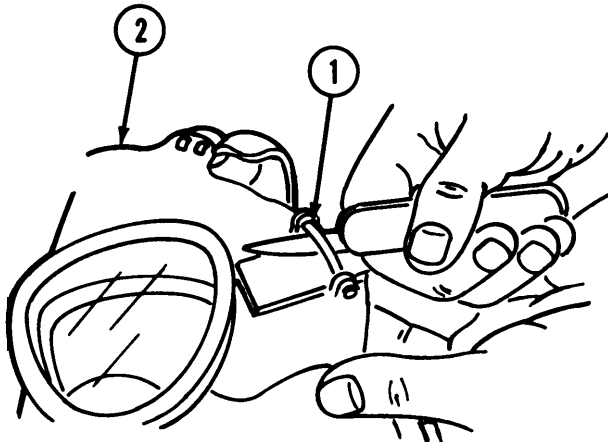

Remove temple pin (1) from facepiece assembly (2) by cutting the temple pin with a knife and removing the pieces.

## REPAIR

Replace unserviceable authorized parts. See appendix C.

## REASSEMBLY

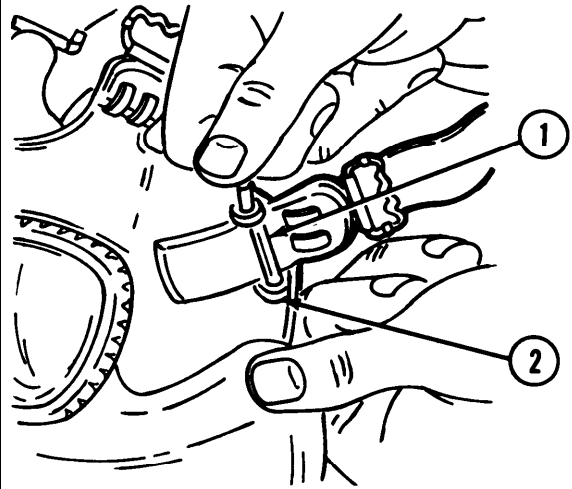

- a. Moisten new temple pin (1) with water.
- b. Starting from above or below lugs molded in the faceblank, thread tail of temple pin (1) through hole in one lug (2). Grasp protruding portion of tail and pull one knob of temple pin (1) through the hole. Thread tail through second hole, and pull knob through that hole.
- c. Cut off tail.

**2-14. FACEPIECE ASSEMBLY (CONT).**

d. *Short and Long Flap Buttons.*

**DISASSEMBLY**

**1**

- a. Turn head harness (1) inside out for access to nose-cup (2).
- b. Unbutton nosecup from two long flap buttons (3).

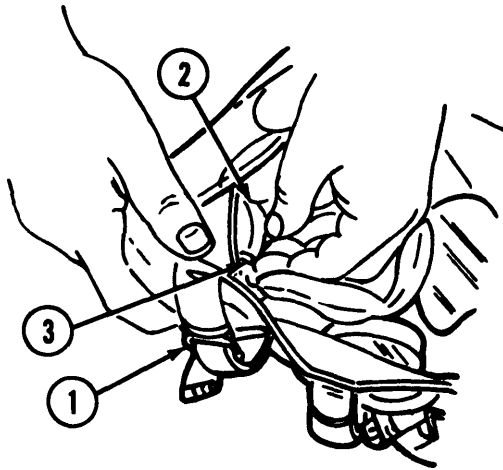

**2**

- a. Unbutton flaps from two long flap buttons (3), and two short flap buttons (4) in filter pouch flaps (5).

**CAUTION**

Do not attempt to pass large ends of long and short flap buttons through holes in rubber flaps. This may tear facepiece.

- b. Grasp large end of button and pull small end through hole.

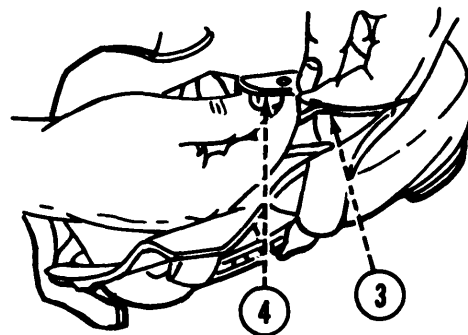
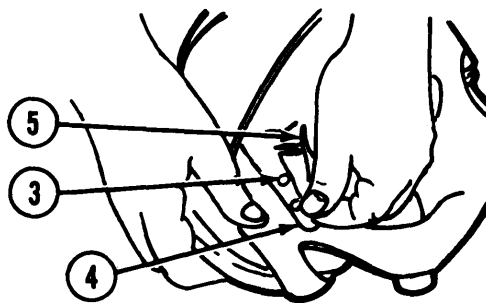

**REPAIR**

Replace unserviceable authorized parts. See appendix C.

## REASSEMBLY

**1**

**CAUTION**

Do not attempt to install large ends of flap buttons through holes in rubber flaps. This may tear facepiece.

**NOTE**

Flap buttons may be lubricated by moistening with water to ease buttoning.

Install two short flap buttons (1) in hole nearest outer edge of facepiece. Using one finger to support bottom of button, force button head through hole so that base of button is inside pouch and head protrudes into cavity of facepiece.

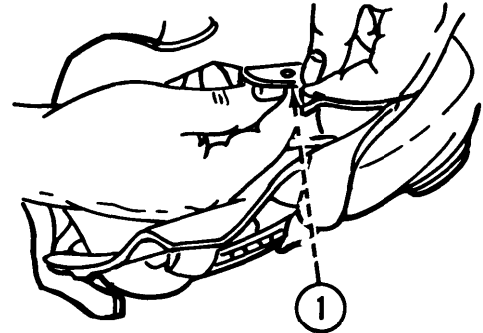

**2**

Install two long flap buttons (2) in hole nearest the voicemitter in the same manner.

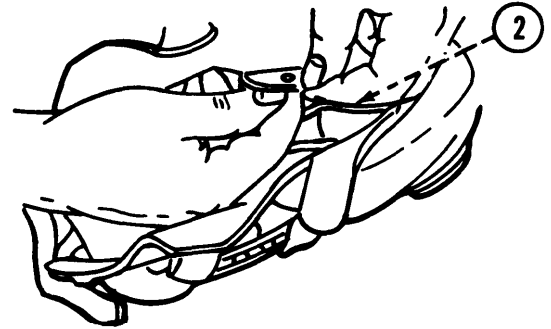

**3**

Button two short flap buttons (1) and two long flap buttons (2) on two filter pouch flaps (3).

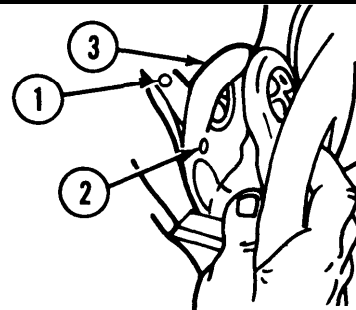

**4**

- a. Button two long flap buttons (2) to nosecup assembly flaps (4).
- b. Return head harness (5) to original position.

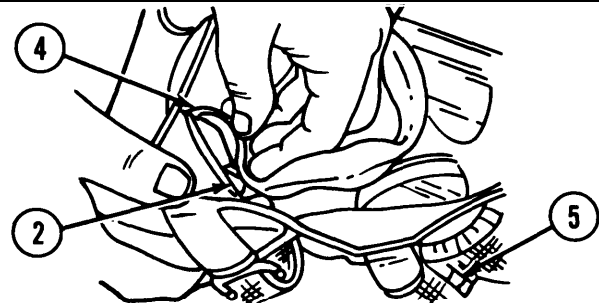



## 2-14. FACEPIECE ASSEMBLY (CONT).

e. *Voicemitter-Outlet Valve Assembly Cover and Quick Disconnect Coupling Half.*

### DISASSEMBLY

# 1

(M17A1/M17A2 mask only). Remove quick disconnect coupling half (1) and hose (tube for water intake) from pocket (2) and channel (3) in voicemitter-outlet valve assembly cover.

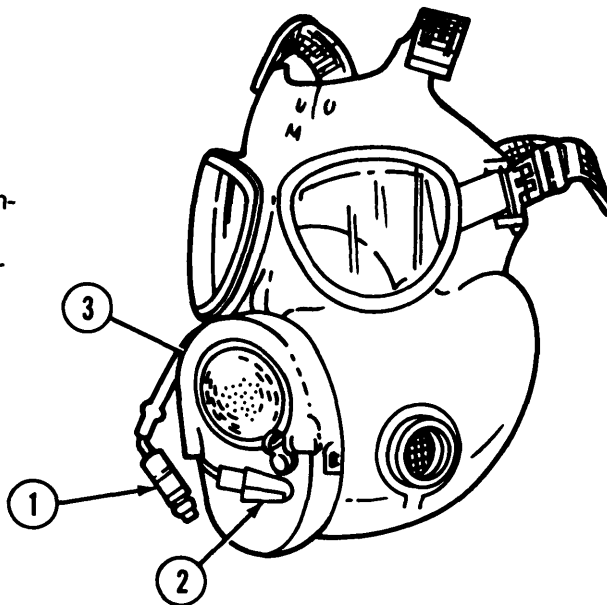

# 2

Grasp tab (4) at bottom of voicemitter-outlet valve assembly cover (5) and lift bottom portion of cover from outlet valve (6).

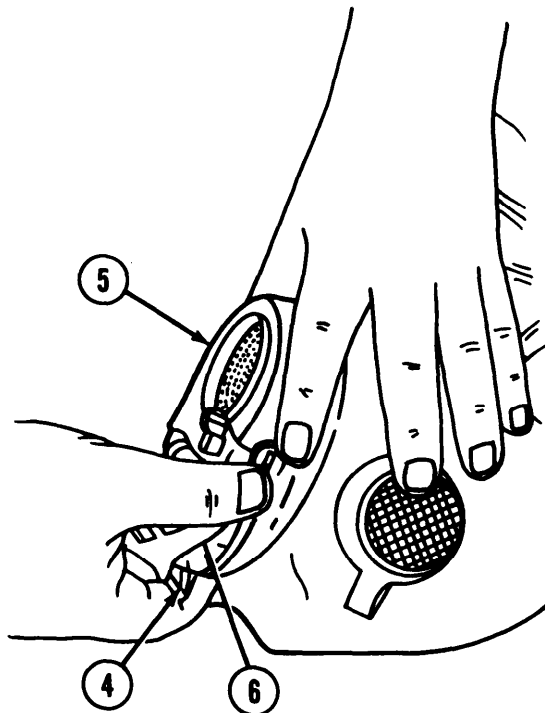

### 3

- a. Pull sides of cover (5) away from crimping ring (7) until the cover is detached from studs (8) that hold it in place.
- b. Pull upper portion of cover (5) from beneath the flange around the voicemitter-outlet valve assembly (9).

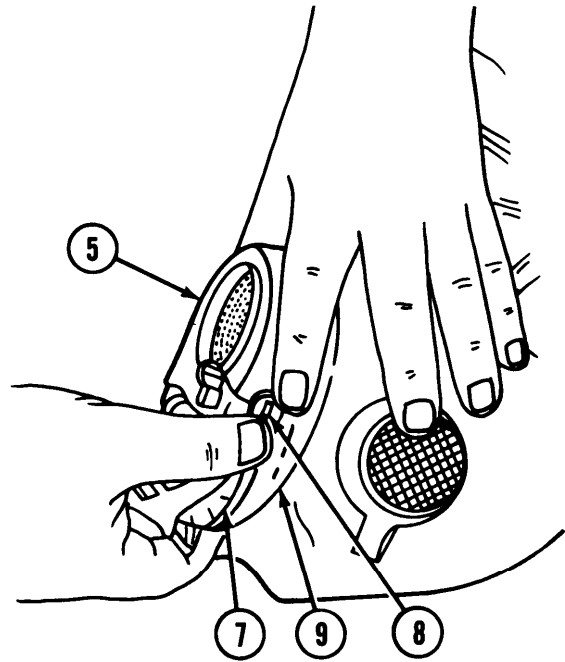

### 4

- a. Remove cover (5) from groove around voicemitter-outlet valve assembly (9).
- b. (M17A1/M17A2 mask only). Remove quick-disconnect coupling half (1) from the adapter (10) on voicemitter-outlet valve assembly (9).

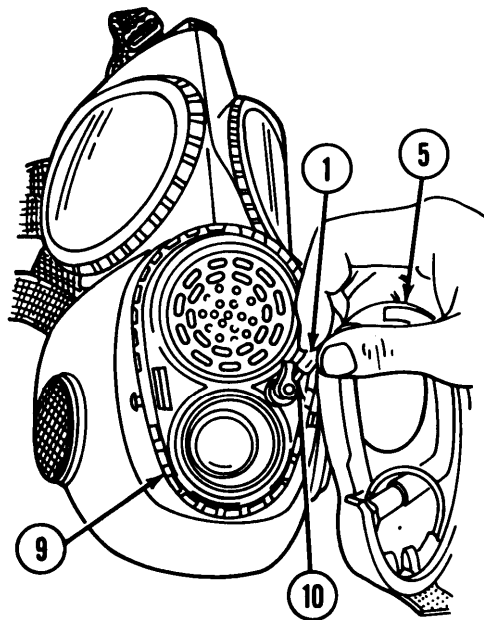

### 5

- a. (M17A1/M17A2 mask only). Pull quick disconnect coupling half (1) through hole in cover (5).
- b. (M17A1/M17A2 mask only). Remove voicemitter-outlet valve assembly cover (5) from groove around voicemitter-outlet valve assembly (9).

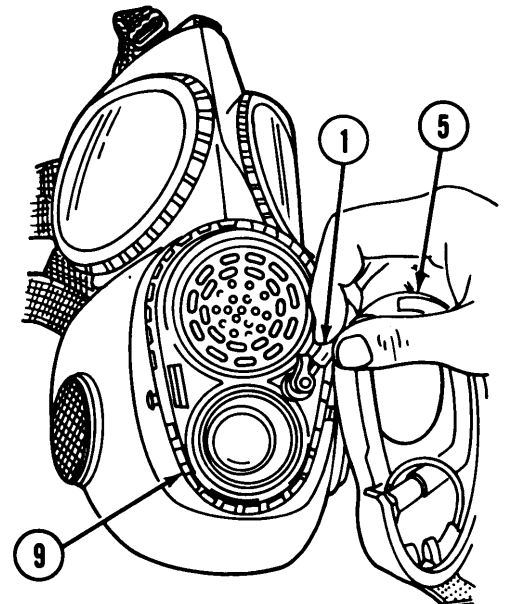

## 2-14. FACEPIECE ASSEMBLY (CONT).

e. *Voicemitter-Outlet Valve Assembly Cover and Quick Disconnect Coupling Half (Cont).*

### REPAIR

Replace unserviceable authorized parts. See appendix C.

### REASSEMBLY

# 1

- a. (M17A1/M17A2 mask only). Dip tube end of quick disconnect coupling half (1) in water to moisten.
- b. (M17A1/M17A2 mask only). Pull free end of quick disconnect coupling half (1) through opening in channel at top of voicemitter-outlet valve assembly cover (2). (This opening cannot be seen from front of cover.)
- c. (M17A1/M17A2 mask only). Attach tube end of quick disconnect coupling half (1) to adapter (3).

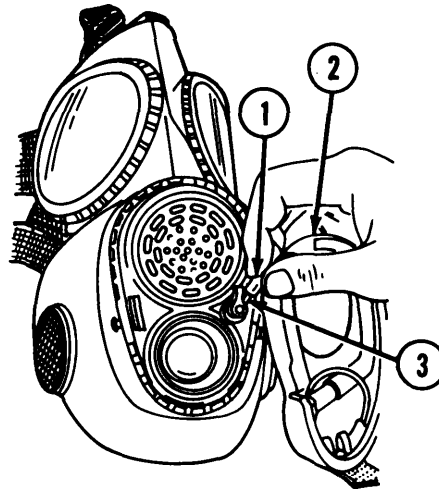

# 2

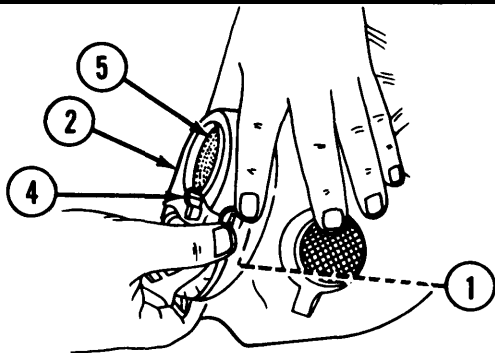

- a. (M17A1/M17A2 mask only). Install voicemitter-outlet valve assembly cover (2) over lever (4).
- b. Fit cover (2) over voicemitter-outlet valve assembly (5).
- c. (M17A1/M17A2 mask only). Make sure that any excess length of quick disconnect coupling half (1) has been pulled from beneath cover (2).

# 3

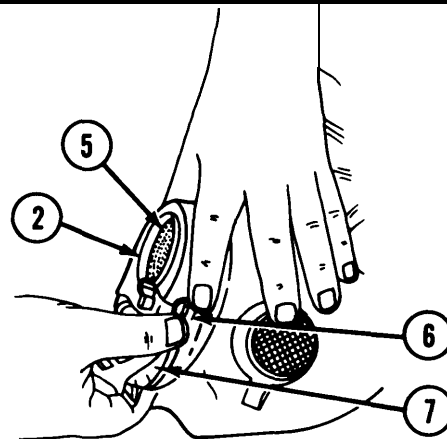

- a. Fit openings at sides of cover over studs (6).
- b. Insert voicemitter-outlet valve assembly cover (2) into groove (7) around voicemitter-outlet valve assembly (5).
- c. Grasp tab at bottom of cover (2) and pull bottom portion of cover over bottom of voicemitter-outlet valve assembly (5).

**4**

(M17A1/M17A2 mask only). Put quick disconnect coupling half (1) in pocket (8), and press tube end of quick disconnect coupling half (1) into channel (9).

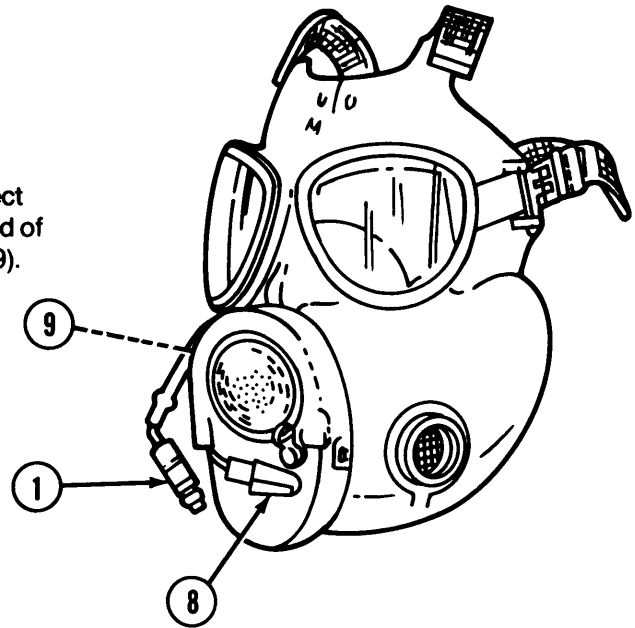

f. Nosecup Valve Disk.

## DISASSEMBLY

**1**

Reverse head harness (1) by lengthening all straps, and looping head harness (1) over front of facepiece.

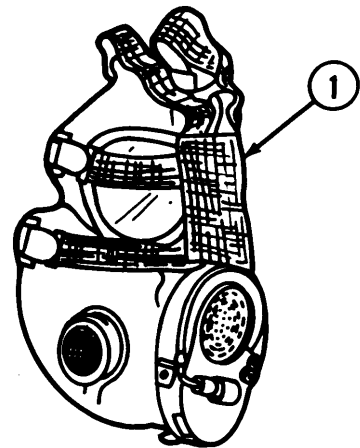

## 2-14. FACEPIECE ASSEMBLY (CONT).

### f. Nosecup Valve Disk (Cont).

**2**

**NOTE**

Steps a and b are for the removal of one valve disk and should be repeated for the other.

- a. Curl back lip of nosecup to expose valve (2).

**CAUTION**

To avoid tears, do not stretch rubber more than necessary to remove or install parts.

- b. With other hand, lift edges of valve disk (3) with fingernail, and grasp edge between thumb and forefinger. Gently stretch hole just enough to remove valve disk (3) from stud (4).

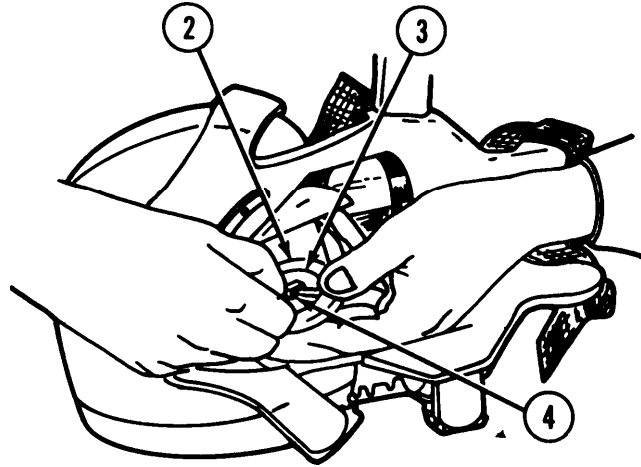

## REPAIR

Replace unserviceable authorized parts. See appendix C.

## REASSEMBLY

**CAUTION**

To avoid tears, do not stretch rubber more than necessary to remove or install parts.

**NOTE**

Steps a and b are for reassembly of one valve disk and should be repeated for the other.

- a. Install valve disk (1) by slipping edge of hole on stud (2) with thumb and forefinger and gently stretching valve disk (1) over stud (2).
- b. Be sure that valve disk (1) is flat on nosecup valve seat (3).
- c. Return lip to normal position.
- d. Return head harness (4) to normal position and adjust head harness straps. See paragraph 2-9 for procedure to adjust head harness straps.

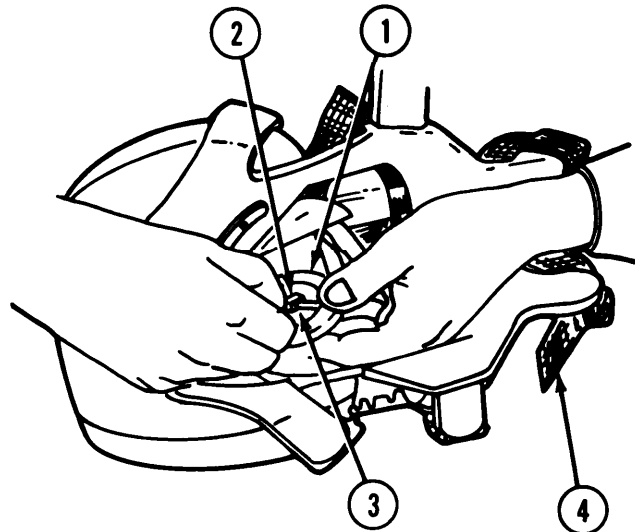

g. *Outlet Valve Disk.*

**DISASSEMBLY**

- a. Lift lower portion of voicemitter-outlet valve assembly cover (1).
- b. Pinch outlet valve disk (2) between thumb and forefinger, and pull outlet valve disk from outlet valve seat (3).
- c. Discard outlet valve disk (2).

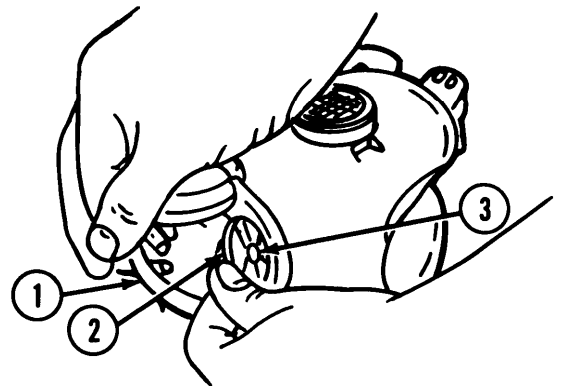

**REPAIR**

Replace unserviceable authorized parts. See appendix C.

**REASSEMBLY**

**1**

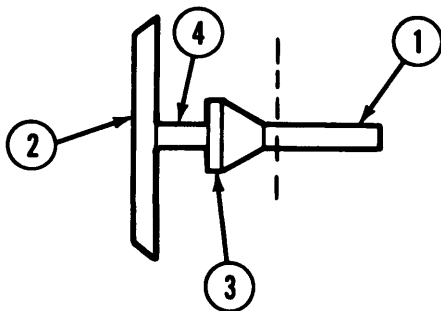

- a. Cut tail (1) of new outlet valve disk (2) back almost to tapered end of cone (3) (M17A1 only).
- b. Moisten cone (3) and stem (4) of new outlet valve disk (2) with water or saliva.

**2**

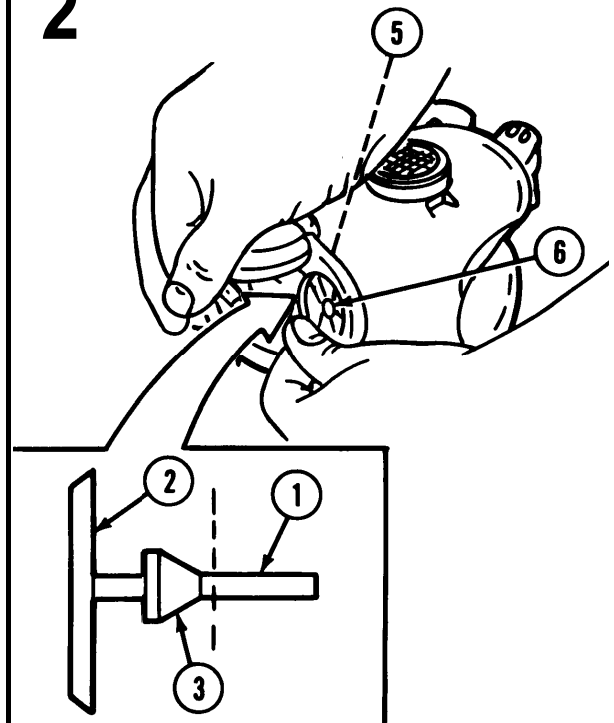

**NOTE**

When installing outlet valve disk on M17 or M17A2 mask, the tail (1) may be used to pull the outlet valve disk (2) into place from the inside of facepiece.

Start tapered end of cone (3) of new outlet valve disk (2) through holes (5) in middle of outlet valve seat (6).

## 2-14. FACEPIECE ASSEMBLY (CONT).

### g. Outlet Valve Disk (Cont).

# 3

- a. With rotating motion, press the new outlet valve disk (2) in until shoulder of cone (3) slips through hole in outlet valve seat (6).
- b. Check that new outlet valve disk (2) lies flat and smooth and has continuous contact with outlet valve seat (6).
- c. Reseat voicemitter-outlet valve assembly cover (7).

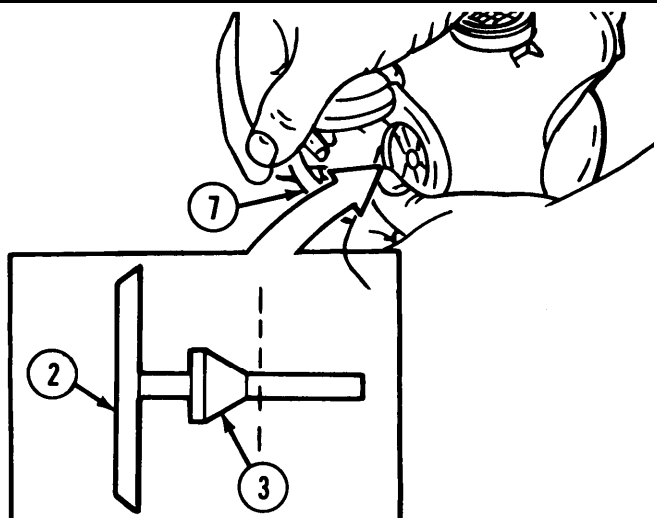

### h. Filter Element Set.

## DISASSEMBLY

# 1

### WARNING

Dirt or other foreign material on the connectors of filter elements, mating surfaces of the faceblank, or trapped between these surfaces lets contaminated air into your facepiece.

### NOTE

To determine whether filter element replacement is required, refer to paragraph 2-11.

# 2

Remove inlet valve assemblies (1) from the side of the facepiece by pushing upon bottom edge of inlet valve assemblies with thumbs.

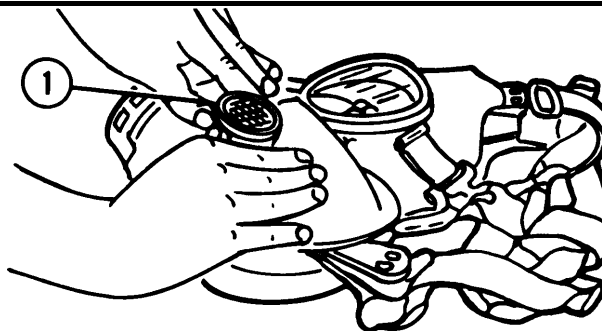

# 3

Work collar (2) from under filter element connector flange (3).

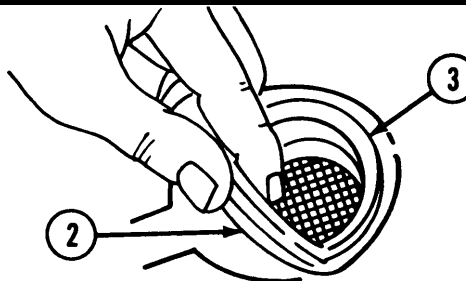

4

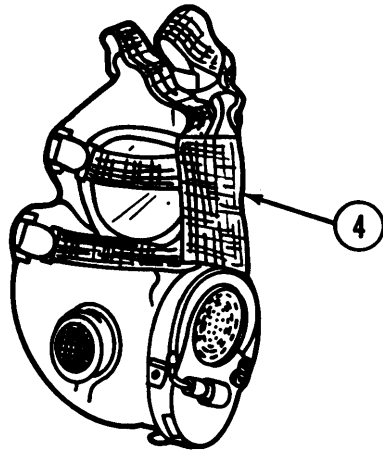

Reverse head harness (4) by lengthening all straps and looping head harness over front of facepiece.

5

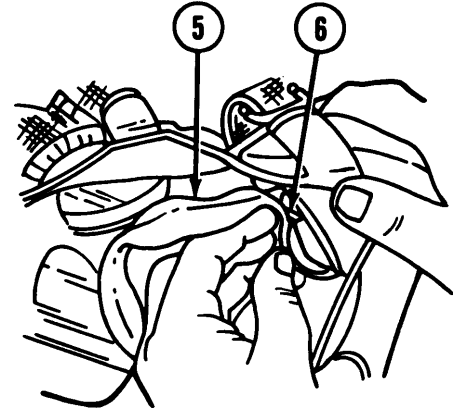

Unbutton nosecup assembly flaps (5) from two long flap buttons (6).

6

**CAUTION**

To avoid tears, do not stretch rubber any more than necessary to remove or install parts.

Unbutton two pouch flaps (7) from two long flap buttons (6) and two short flap buttons (8).

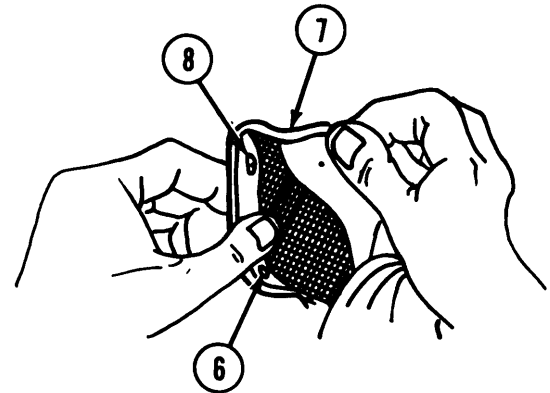

7

Grasp upper part of fitter element (9) between fingers and thumb.

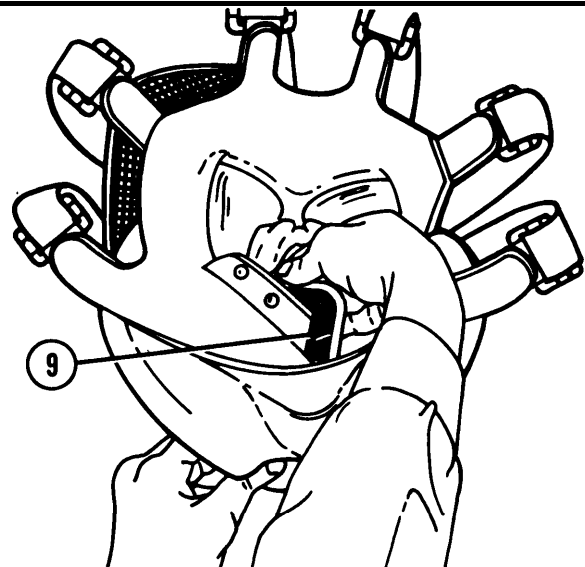



## 2-14. FACEPIECE ASSEMBLY (CONT).

### h. Filter Element Set (Cont).

**8**

With other hand, grasp outside of facepiece assembly between voicemitter-outlet valve assembly (10) and filter element connector flange (3) and pull filter element (9) from facepiece.

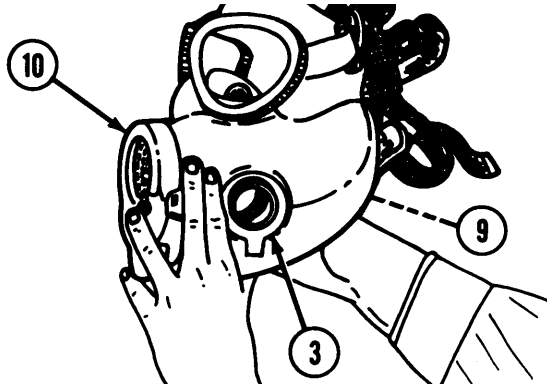

## REPAIR

Replace unserviceable authorized parts. See appendix C.

## REASSEMBLY

**1**

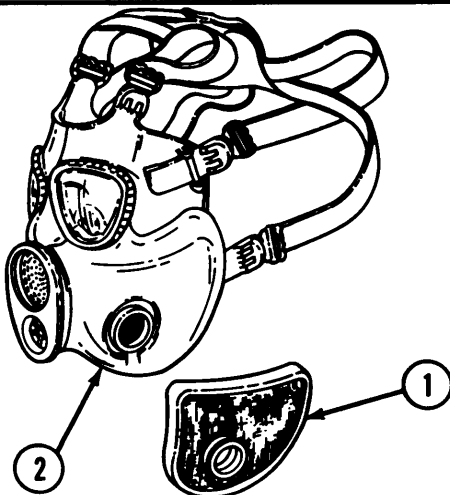

### NOTE

Install only matched sets of the same lot number. Filter elements are marked either right or left and must be identically matched by the lot number. Water resistance rating must be within 5 mm. The numbers are marked on the edge of the filter elements.

Align filter elements (1) with outside contours of cheek pouches (2) to be sure of correct installation.

**2**

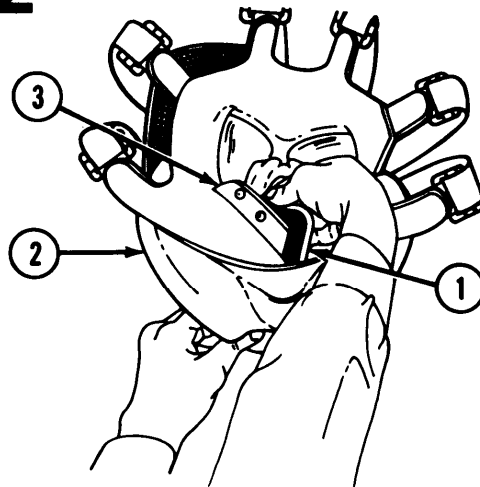

- a. Hold filter element (1) by square corner with your fingers on the connector side. And with your other hand, pull lower pouch flap (3) outward just enough to open cheek pouch.
- b. Insert curved edge of filter elements (1) into cheek pouch (2) with a slight turning motion. Push filter element (1) up into cheek pouch (2).
- c. Grasp corner of filter element (1) that was first inserted and work into place.

3

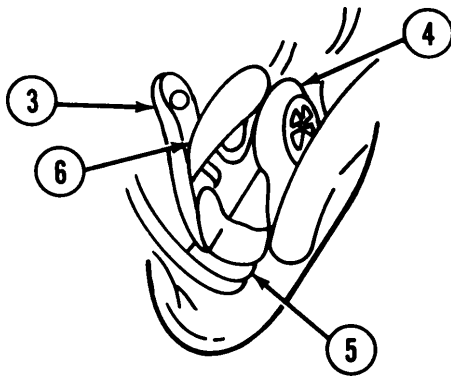

**CAUTION**

Make sure that bottom of nosecup assembly (4) is positioned on top of chin stop (5) so moist exhaled air does not enter cheek pouches and damage filter elements.

Allow nosecup assembly flaps (6) and pouch flap (3) to fall into normal position.

4

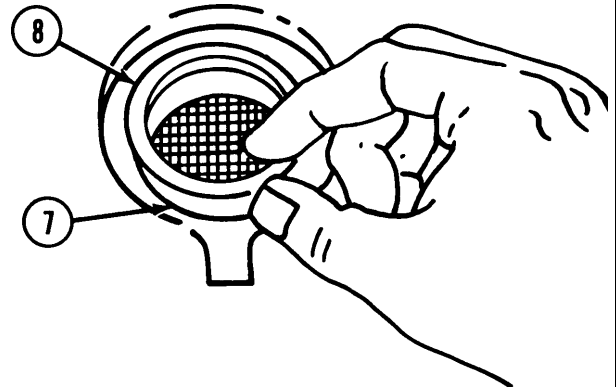

- a. Work collar (7) under filter elements connector flange (8) and recheck filter element position.
- b. Adjust, if necessary.

5

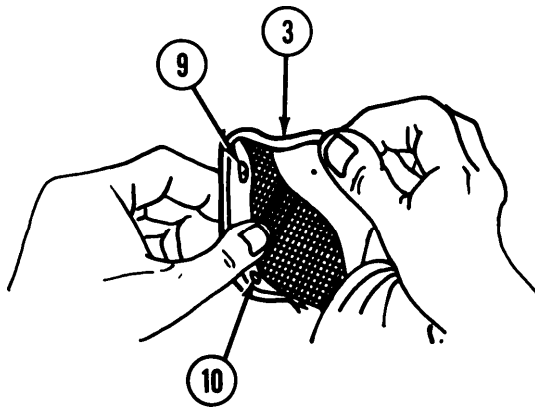

**NOTE**

Flap buttons may be lubricated by moistening with water to ease buttoning.

Button two pouch flaps (3) on two short flap buttons (9) and two long flap buttons (10).

6

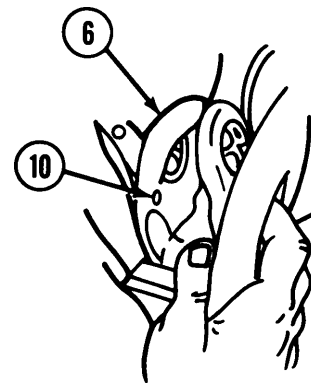

Button nosecup assembly flaps (6) on two long flap buttons (10).

## 2-14. FACEPIECE ASSEMBLY (CONT).

### h. Filter Element Set (Cont).

# 7

- a. Return head harness (11) to normal position and adjust head harness straps as required.
- b. Position inlet valve (12) over filter element connector flange (8) with the word TOP toward top of mask or until louvers are horizontal and slanted down away from filter element.

#### NOTE

Install inlet valve (12) so that the word TOP is directly opposite the groove (13) below the inlet valve opening on the faceblank. The word TOP may be missing or incorrectly positioned. Exact top may be marked with a white dot.

- c. Snap inlet valve (12) into place.

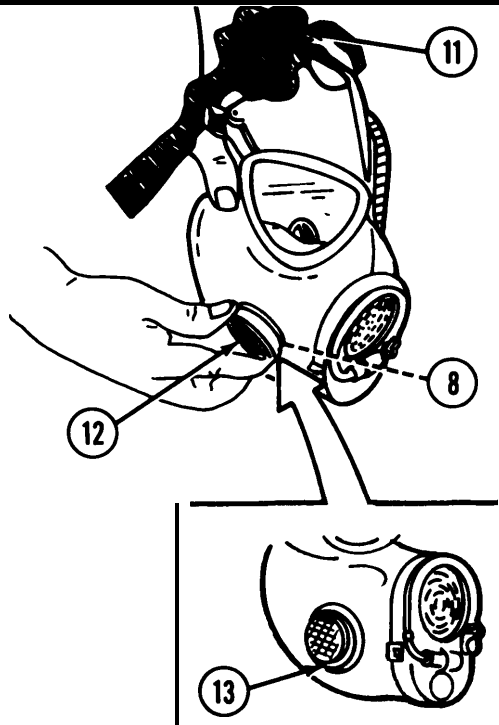

## 2-15. CHEMICAL INLET VALVE ASSEMBLY.

This task covers:

- a. Disassembly
- b. Repair
- c. Reassembly

### INITIAL SETUP

*Tools and Special Tools*

Thumbsaver (fig E-1) (optional or desired)

### DISASSEMBLY

# 1

#### NOTE

The following procedures are for the removal of one chemical inlet valve assembly and should be repeated for the other inlet valve assembly. Replace both valve disks if one is faulty.

# 2

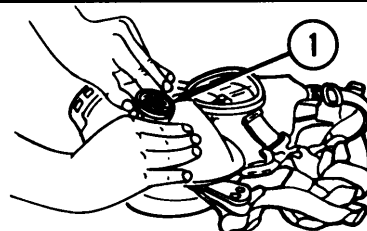

Remove chemical inlet valve assembly (1) from the facepiece by pushing upon bottom edge of inlet valve assembly with thumbs or thumbsaver.

# 3

**CAUTION**

To avoid tears, do not stretch rubber more than necessary to remove or install parts.

Lift edge of valve disk (2) with fingernail and grasp edge between thumb and forefinger. Stretch the hole and remove valve disk (2) from stud (3).

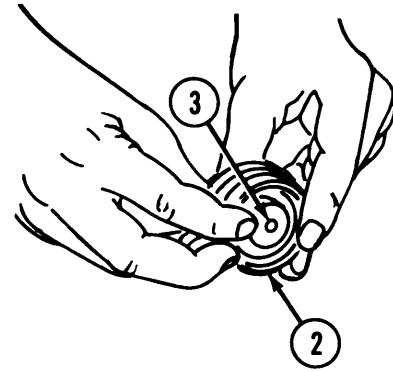

**REPAIR**

Replace unserviceable authorized parts. See appendix C.

**REASSEMBLY**

**NOTE**

The following procedures are for the installation of one chemical inlet valve assembly and should be repeated for the other chemical inlet valve assembly.

The word TOP may be missing or incorrectly positioned. Exact top may be marked with a white dot. The word TOP or the white dot indicate the louvers are horizontal and slanted down away from the filter elements.

**1**

Diagram 1 shows a hand holding an inlet valve cap cover (2) with the mesh side facing the viewer. A dashed line labeled 'TOP' points to the top edge. A dashed line labeled '1' points to the louvers. A dashed line labeled 'LIGHT SOURCE' points to the right. The cap cover is tilted slightly towards the viewer.

Check position of louvers (1) by holding inlet valve cap cover (2), with mesh side facing you, to a light source. Tilt bottom of inlet valve cap cover (2) towards you. Light source should be visible with the louvers horizontal.

**2**

Diagram 2 shows the same hand holding the inlet valve cap cover (2). The cap cover is now tilted more towards the viewer. A dashed line labeled 'TOP' points to the top edge. A dashed line labeled '1' points to the louvers. A dashed line labeled 'LIGHT SOURCE' points to the right. The light source is now visible through the louvers.

Tilt bottom of inlet valve cap cover (2) toward light source. Light spaces between louvers (1) should diminish and disappear.

**2-15. CHEMICAL INLET VALVE ASSEMBLY (CONT).**

**REASSEMBLY (CONT)**

**3**

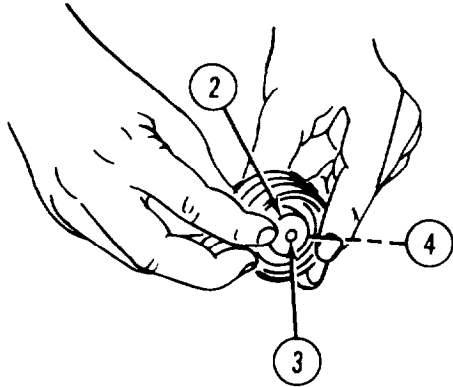

- a. Install valve disk (3) by using thumb and forefinger to stretch edge of hole over stud of inlet valve cap cover (2)
- b. Rotate to be sure valve disk (3) does not stick and rests flat on inlet valve seat (4).

**4**

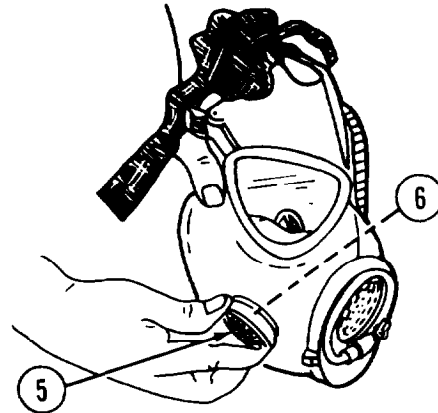

- a. Position chemical inlet valve assembly (5) over one side of filter element connector flange (6) with the word TOP or white dot toward top of mask when the facepiece is in the as-worn position, or until louvers are horizontal and slanted down away from the filter element.
- b. Snap chemical inlet valve assembly (5) into place.

**Section VII. CLEANING AND SANITIZING MASK**

**2-16. CLEANING AND SANITIZING.**

This task covers:

- a. Cleaning
- b. Sanitizing

**INITIAL SETUP**

*Tools and Special Tools*

Thumbsaver (fig E-1) (optional or desired)

*Materials/Parts*

- Calcium hypochlorite (item 7, app D)
- Canteen, water (item 8A, app D)
- Cheesecloth (item 10, app D)
- Isopropyl rubbing alcohol (item 12, app D)
- Lens and photographic negative dusting brush (item 4, app D)
- Measuring spoon (item 20, app D)
- Optical lens cleaning compound (item 9, app D)
- Pastic polish (item 18, app D)

- Scrub brush (item 5, app D)
- Small cleaning brush (item 3, app D)
- Toilet soap (item 19, app D)
- Utility pail (item 16, app D)

*Reference*

TM 3-4240-279-10

a. *Cleaning.*

**NOTES**

Use only potable water to clean a mask.

Mask must be clean and sanitized before transferring to another soldier.

- a. Remove voicemitter-outlet valve assembly cover (1) (para 2-14).
- b. Remove chemical inlet valve assemblies (2) (para 2-15). Use thumbsaver if desired.
- c. Remove eyelens outserts (3) (TM 3-4240-279-10).

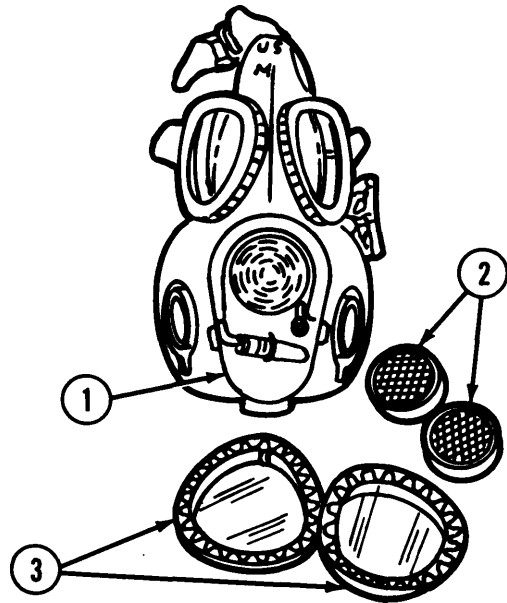

**2**

- a. Remove greasy or oily substances from the facepiece assembly (4) with isopropyl alcohol on a clean cloth.
- b. Clean mask inside and out with clean cheesecloth and toilet soap. Dip cloth in warm soapy water and wring cloth almost dry. Lens brush may also be used.

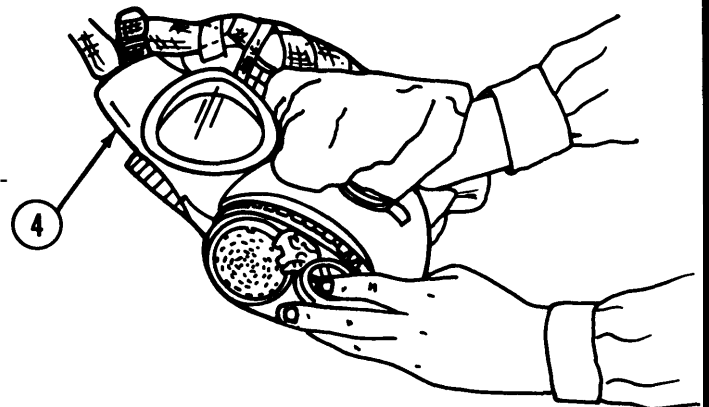

2-16. CLEANING AND SANITIZING (CONT).

a. *Cleaning (Cont).*

**3**

- a. Rinse facepiece assembly (4) with clean cheese-cloth that has been dipped in warm clear water and wrung almost dry.
- b. Dry facepiece with lint-free cloth or allow to air-dry.

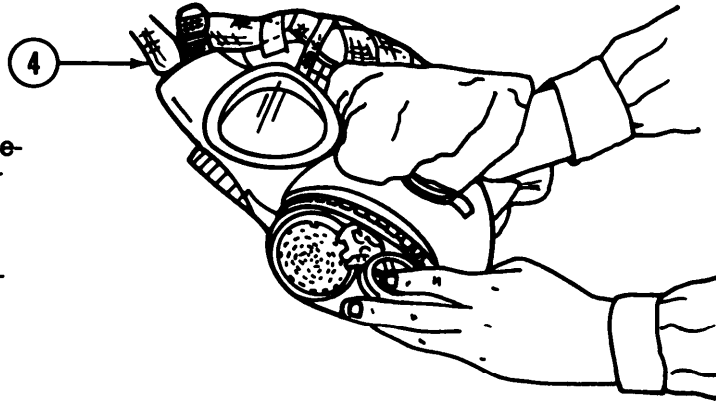

**4**

- a. Clean eyelenses (5) and eyelens outserts (3) with optical lens cleaning compound and plastic polish.
- b. Install eyelens outserts (3) (TM 3-4240-279-10).

**CAUTION**

Do not brush chemical inlet valve assemblies too hard or you will tear the mesh.

- c. Using small cleaning brush, gently brush mesh of chemical inlet valve assemblies (2) to remove dirt.
- d. Install chemical inlet valve assemblies (2) (para 2-15).
- e. Install voicemitter-outlet valve assembly cover (1) (para 2-14e).

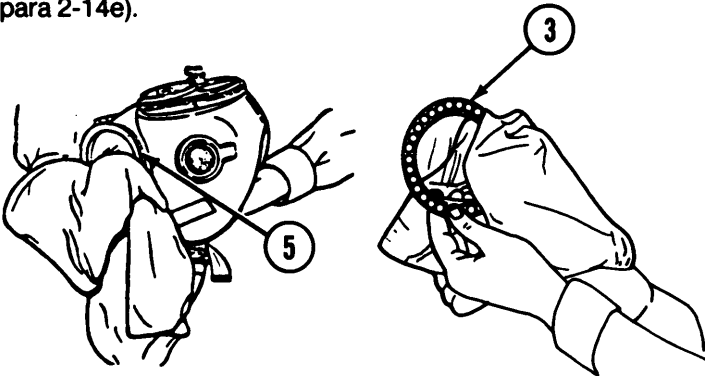
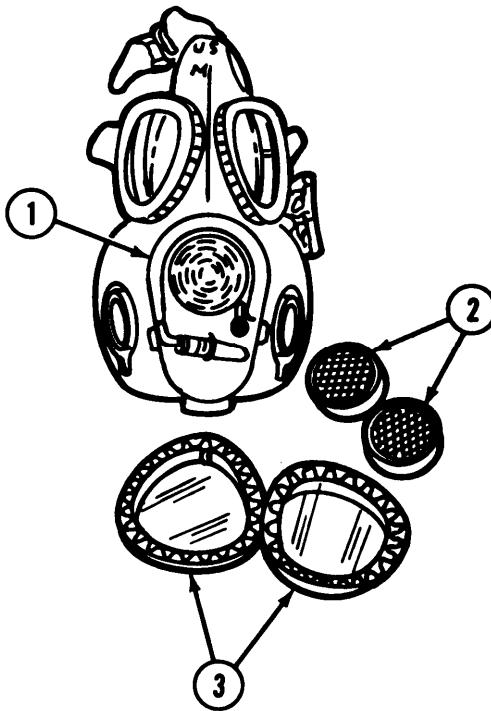

# 5

## CAUTION

Do not use hot water, bleach, or detergents, or soak or immerse carrier (6) to clean it.

## NOTE

When using scrub brush to clean carrier, immerse scrub brush in cool water, lift from water, let excess water drain, then use scrub brush on carrier.

- a. Check that carrier is free of any foreign matter. Shake out any loose foreign material, Clean soiled carrier with a scrub brush.
- b. Check the D-ring to ensure that it is not cut or split by pulling both ends of the D-ring (fingers placed inside) with vigorous pulling action. If the D-ring splits, the carrier needs to be replaced.

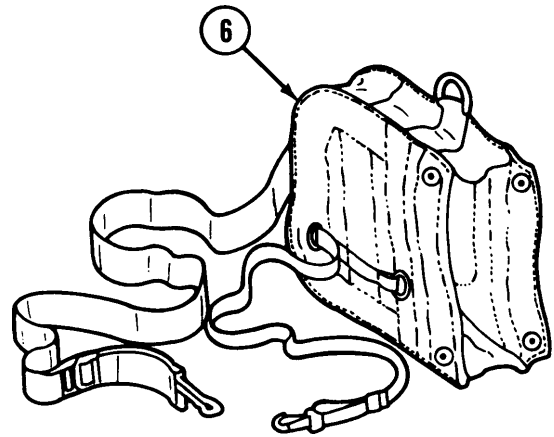

### b. Sanitizing.

# 1

## NOTE

When you sanitize a mask, use only potable water. Either remove the head harness prior to sanitizing the facepiece or permit a wet head harness to dry prior to replacing the facepiece in the carrier.

- a. Remove chemical inlet valve assemblies (1) (para 2-15).
- b. Remove eyelens outserts (2) (TM 3-4240-279-10).
- c. Remove hood (3) (TM 3-4240-279-10).
- d. Remove filter elements (4) (para 2-14h).
- e. Remove nosecup valve (para 2-149).

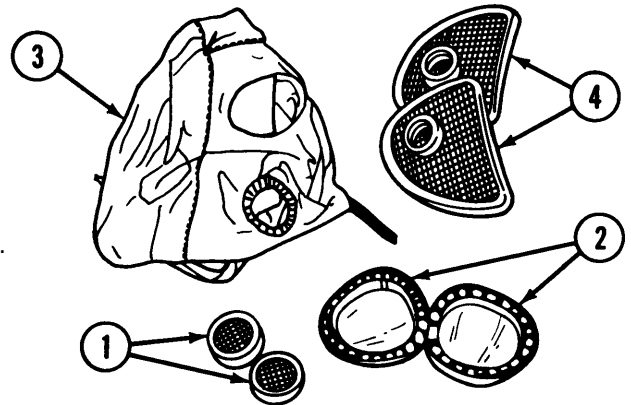

## CAUTION

Set filter elements aside so they will not get wet or damaged.

- f. Immerse facepiece (5) and eyelens outserts (2) in utility pail filled with warm soapy water. Agitate for 2 or 3 minutes. Rinse twice in clear warm water. Agitate 2 or 3 minutes each time.

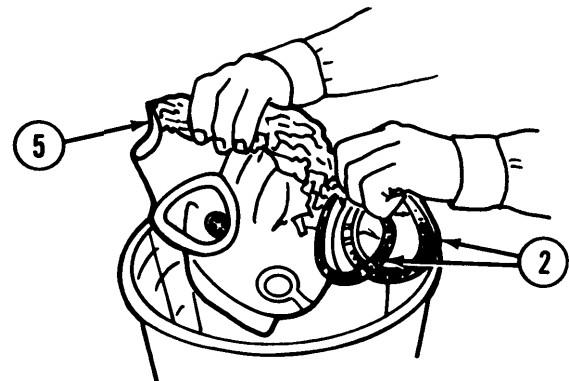



**2-16. CLEANING AND SANITIZING (CONT).**

b. *Sanitizing (Cont).*

**2**

- a. Add a level 1/2 teaspoon of calcium hypochlorite to 1 gallon of dean water in a utility pail.

**NOTE**

0.5 gram tube of calcium hypochlorite can be used until supply is exhausted.

- b. Mix thoroughly for 30 seconds to dissolve calcium hypochlorite.
- c. Remove cap (6) and fill canteen (7) with this solution and put cap (6) on canteen (7).
- d. Save the rest of the water for sanitizing the facepiece.

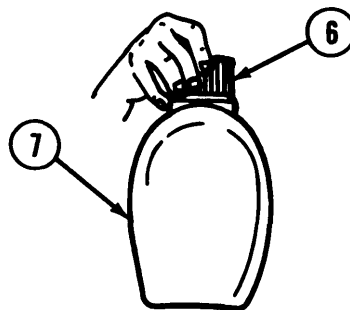

**3**

- a. Open protective cover (8). Position facepiece (5) faceup.
- b. Attach quick disconnect coupling half (9) to cap (6).
- c. Invert canteen (7) above facepiece; turn lever (10) toward voicemitter (11). Squeeze canteen to force the sanitizing solution through the quick disconnect coupling half (9).
- d. Lower canteen (7) to upright position or squeeze sides to vent canteen (7). Use entire contents and rinse twice with dean water in same way.

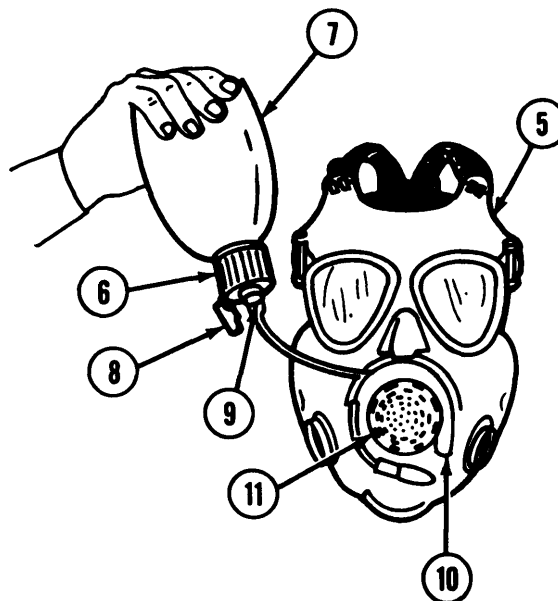

# 4

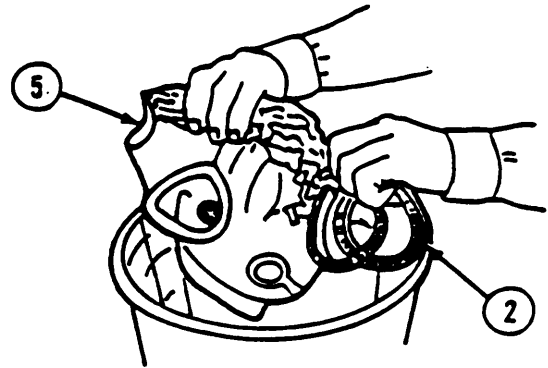

**NOTE**

Prepare enough sanitizing solution to cover facepiece and eyelens outserts. (See step 2, page 2- 50).

- a. Immerse facepiece (5) and eyelens outserts (2) and agitate for 5 minutes.
- b. Rinse twice in clear warm water, agitating 2 or 3 minutes each time.
- c. Dry all parts with clean lint-free cloth or allow to air-dry.

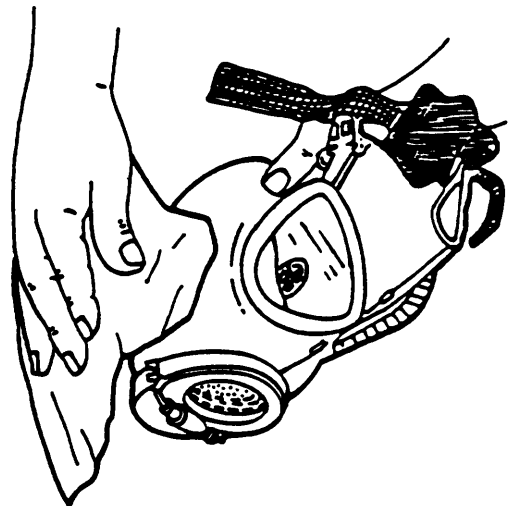

# 5

**CAUTION**

To prevent mildewing, ensure head harness is dried thoroughly before stowing.

**NOTE**

The nosecup valve and inlet valve assembly will be replaced when the mask is sanitized.

Install head harness (if removed for sanitizing).

- a. Install nosecup valve (para 2-14f).
- b. Install filter elements (4) (para 2-14h).
- c. Install hood (3) (TM 3-4240-279-10).
- d. Install eyelens outserts (2) (TM 3-4240-279-10).
- e. Install chemical inlet valve assembly (1) (para 2-15).

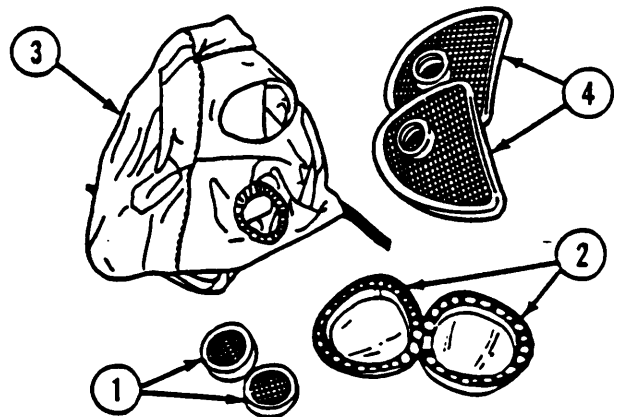

Section VIII. PREPARATION FOR STORAGE OR SHIPMENT

2-17. PREPARATION FOR STORAGE OR SHIPMENT.

a. *Storage by Using Unit.*

Use either the fiberboard boxes or the plywood boxes for unit storage by stacking them on their sides to form a bank of storage cells. Fiberboard boxes should not be stacked more than three high.

b. *Storage by Individual.*

**CAUTION**

Store masks in a cool, dry place, 40°F to 90°F (4°C to 32°C). Heat and moisture will damage the mask and the filter material.

(1) Hang the carrier either by the shoulder strap or by the D-ring on the short strap on top of the carrier.

(2) Stow straps as directed by the local commander. Both straps may be hooked to the D-rings by their snap hooks.

c. *Shipment.* To prevent damage to CB masks being turned in as serviceable, unserviceable and/or excess, while in transit or storage, prepare and package the masks for shipment as follows:

(1) Clean mask in accordance with TM 3-4240-279-20&P, Section VII, paragraph 2-16.

(2) Masks will be returned with filter elements installed (expired filter elements may be Used).

(3) Remove and retain M6A2 hood and install eyelens outserts on the facepiece.

(4) Leave the M1 or M1A1 waterproof bag in the carrier.

(5) Wrap mask facepiece assembly with one turn of cushioning material (item 22, app D) (minimum 1/4 inch thick). Overlap and secure ends with tape (item 23, app D). Place wrapped mask assembly in the M15A1 carrier and close flap.

(6) Attach a shoe tag to the "D" ring on the carrier with the NSN of the mask enclosed.

**NOTE**

Other additional authorized items are to be retained.

(7) Place mask carrier assembly (ies), (maximum 10), in one layer into a weather resistant fiberboard box shipping container of minimum size to prevent crushing of assemblies. Voids in the box should be filled with cushioning material (item 22, app D).

(8) Seal the shipping container with tape (item 23, app D), applied twice around the girth, evenly spaced.

(9) The fiberboard box may be packed in a cleated plywood box. Use six cleated box fasteners to secure the top of the box, two on each side and one on each end.

(10) Secure a shipping document envelope on the side of the shipping container with the enclosed DD Form(s) 1348 for each NSN being shipped (AR 725-50, Sec II, pm 7-11).

## APPENDIX A REFERENCES

---

**A-1. SCOPE.** This appendix lists all forms, field manuals, technical manuals, and other publications referenced in this manual.

**A-2. FORMS.**

DA Form 2028-2 .....	Recommended Changes to Equipment Technical Publications
DA Form 2028 .....	Recommended Changes to Publications and Blank Forms
DA Form 2404 .....	Equipment Inspection and Maintenance Worksheet
DD Form 314 .....	Preventive Maintenance Schedule and Record
SF 364 .....	Report of Discrepancy (ROD).
SF 368 .....	Quality Deficiency Report

**A-3. FIELD MANUALS.**

FM 21-11 .....	First Aid for Soldiers
----------------	------------------------

**A-4. TECHNICAL MANUALS.**

TM 3-4240-279-10 .....	Operator's Manual, Mask, Chemical-Biological: Field, ABC-M17, M17A1, and M17A2
TM 43-0002-31 .....	Destruction of Chemical Weapons and Defense Equipment to Prevent Enemy Use

**A-5. MISCELLANEOUS.**

AR 40-63 .....	Ophthalmic Services
AR 70-38 .....	Research, Development, Test, and Evaluation of Materiel for Extreme Climatic Conditions
AR 700-84 .....	Issue and Sale of Personal Clothing
CTA 8-100 .....	Army Medical Department Expendable/Durable Items
CTA 50-970 .....	Expendable Items (Except Medical, Class V, Repair Parts, and Heraldic Items)
DA PAM 738-750 .....	The Army Maintenance Management System (TAMMS)
SB 3-30-2 .....	Chemical-Biological Canister, Filter Elements Service List
SB 708-42 .....	Federal Supply Codes for Manufacturers: United States and Canada-Name to Code and Code to Name
TB MED 502 .....	Respiratory Protection Program

\*U.S. GOVERNMENT PRINTING OFFICE: 1989 643-046/00204

## APPENDIX B MAINTENANCE ALLOCATION CHART

### Section I. INTRODUCTION

#### B-1. THE ARMY MAINTENANCE SYSTEM MAC.

a. This introduction (section 1) provides a general explanation of all maintenance and repair functions authorized at various maintenance levels under the standard Army Maintenance System concept.

b. The Maintenance Allocation Chart (MAC) in section II designates overall authority and responsibility for the performance of maintenance functions on the identified end item or component. The application of the maintenance functions to the end item or component will be consistent with the capacities and capabilities of the designated maintenance levels, which are shown on the MAC in column (4) as:

UNIT, which includes two subcolumns, C (operator/crew) and O (unit maintenance)

INTERMEDIATE, which includes two subcolumns, F (intermediate Direct Support) and H (Intermediate General support)

DEPOT, which includes a D (Depot) subcolumn

c. Section III lists the tools and test equipment (both special tools and common tool sets) required for each maintenance function as referenced from Section II.

d. Section IV contains supplemental instructions and explanatory notes for a particular maintenance function.

#### B-2. MAINTENANCE FUNCTIONS.

Maintenance functions will be limited to and defined as follows:

a. *Inspect*. To determine the serviceability of an item by comparing its physical, mechanical, and/or electrical characteristics with established standards through examination (e.g., by sight, sound, or feel).

b. *Test*. To verify serviceability by measuring the mechanical, pneumatic, hydraulic, or electrical charac-

teristics of an item and comparing those characteristics with prescribed standards.

c. *Service*. Operations required periodically to keep an item in proper operating condition; i.e., to clean (includes decontaminate, when required), to preserve, to drain, to paint, or to replenish fuel, lubricants, chemical fluids, or gases.

d. *Adjust*. To maintain or regulate, within prescribed limits, by bringing into proper or exact position, or by setting the operating characteristics to specified parameters.

e. *Align*. To adjust specified variable elements of an item to bring about optimum or desired performance.

f. *Calibrate*. To determine and cause corrections to be made or to be adjusted on instruments or test, measuring and diagnostic equipments used in precision measurement. Consists of comparisons of two instruments, one of which is a certified standard of known accuracy, to detect and adjust any discrepancy in the accuracy of the instrument being compared.

g. *Remove/Install*. To remove and install the same item when required to perform service or other maintenance functions. Install may be the act of emplacing, seating, or fixing into position a spare, repair part, or module (component or assembly) in a manner to allow the proper functioning of an equipment or system.

h. *Replace*. To remove an unserviceable item and install a serviceable counterpart in its place. "Replace" is authorized by the MAC and is shown as the 3d position code of the SMR code.

i. *Repair*. The application of maintenance services, including fault location/ troubleshooting, removal/installation, and disassembly/assembly procedures, and maintenance actions to identify troubles and restore serviceability to an item by correcting specific damage, fault, malfunction, or failure in a part, sub-assembly, module (component or assembly), end item, or system.

j. Overhaul. That maintenance effort (service/action) prescribed to restore an item to a completely serviceable/operational condition as required by maintenance standards in appropriate technical publications (i.e., DMWR). Overhaul is normally the highest degree of maintenance performed by the Army. Overhaul does not normally return an item to like new condition.

k. Rebuild. Consists of those services/actions necessary for the restoration of unserviceable equipment to a like new condition in accordance with original manufacturing standards. Rebuild is the highest degree of materiel maintenance applied to Army equipment. The rebuild operation includes the act of returning to zero those age measurements (hours/miles, etc.) considered in classifying Army equipment/components.

**B-3. EXPLANATION OF COLUMNS IN THE MAC, SECTION II.**

a. *Column 1, Group Number.* Column (1) lists functional group code numbers, the purpose of which is to identify maintenance significant components, assemblies, subassemblies, and modules with the next higher assembly.

b. *Column 2, Component/Assembly.* Column (2) contains the names of components, assemblies, subassemblies, and modules for which maintenance is authorized.

c. *Column 3, Maintenance Function.* Column (3) lists the functions to be performed on the item listed in Column (2).

d. *Column 4, Maintenance Level.* Column (4) specifies, by the listing of a work time figure in the appropriate subcolumn(s), the level of maintenance authorized to perform the function listed in Column (3). This figure represents the active time required to perform that maintenance function at the indicated level of maintenance. If the number or complexity of the tasks within the listed maintenance function vary at different maintenance levels, appropriate work time figures will be shown for each level. The work time figure represents the average time required to restore an item (assembly, subassembly, component, module, end item, or system) to a serviceable condition under typical field operating conditions. This time includes preparation time (including any necessary disassembly/assembly time), troubleshooting/fault location time, and quality assurance/quality control time in addition to the time required to perform the specific tasks identified for the maintenance

functions authorized in the maintenance allocation chart. The symbol designations for the various maintenance levels are as follows:

- C . . . .Operator or Crew
- O . . . .Unit Maintenance
- F . . . .Intermediate-Direct Support Maintenance
- L . . . .Specialized Repair Activity (SRA)
- H . . . .Intermediate-General Support Maintenance
- D . . . .Depot Maintenance

e. *Column 5, Tools and Equipment.* Column (5) specifies, by code, those common tool sets (not individual tools) and special tools, TMDE, and support equipment required to perform the designated function.

f. *Column 6, Remarks.* This column shall, when applicable, contain a letter code, in alphabetic order, which shall be keyed to the remarks contained in Section IV.

**B-4. EXPLANATION OF COLUMNS IN TOOL AND TEST EQUIPMENT REQUIREMENTS, SECTION III.**

a. *Column 1, Reference Code.* The tool and test equipment reference code correlates with a code used in the MAC, Section II, Column (5).

b. *Column 2, Maintenance Level.* The lowest level of maintenance authorized to use the tool or test equipment.

c. *Column 3, Nomenclature.* Name or identification of the tool or test equipment.

d. *Column 4, National Stock Number.* The National stock number of the tool or test equipment.

e. *Column 5, Tool Number.* The manufacturer's part number.

**B-5. EXPLANATION OF COLUMNS IN REMARKS, SECTION IV.**

a. *Column 1, Reference Code.* The code recorded in column (6), Section II.

b. *Column 2, Remarks.* This column lists information pertinent to the maintenance function being performed as indicated in the MAC, Section II.

**Section II. MAINTENANCE ALLOCATION CHART**  
**For**  
**M17, M17A1 and M17A2 CHEMICAL-BIOLOGICAL MASK**

(1) GROUP NUMBER	(2) COMPONENT/ ASSEMBLY	(3) MAINTENANCE FUNCTION	(4) MAINTENANCE LEVEL					(5) TOOLS AND EQPT	(6) REMARKS
			UNIT		INTERMEDIATE		DEPOT		
			C	O	F	H	D		
00	MASK, CHEMICAL- BIOLOGICAL, M17, M17A1 AND M17A2	Inspect	0.5	0.5				1.0	
		Service	0.5	0.6					
		Replace		0.1					
		Repair		0.2					
		Overhaul							
01	FACEPIECE ASSEMBLY	Inspect	0.2	0.2					
		Test		0.1					
		Service	0.5	0.6					
		Adjust		0.1					
		Repair		0.2					
0101	Inlet Valve, Chemical	Inspect	0.1	0.1					
		Service	0.1	0.1					
		Remove/ Install	0.1	0.1					
		Replace		0.1					
		Repair		0.1					

**Section III. TOOL AND TEST EQUIPMENT REQUIREMENTS**

None required.

**Section IV. REMARKS**

Not applicable.

## APPENDIX C

### UNIT MAINTENANCE REPAIR PARTS AND SPECIAL TOOLS LIST

#### Section I. INTRODUCTION

**C-1. SCOPE.** This RPSTL lists and authorizes spares and repair parts; special tools; special test, measurement, and diagnostic equipment (TMDE); and other special support equipment required for performance of unit maintenance of the gas mask. It authorizes the requisitioning, issue, and disposition of spares, repair parts and special tools indicated by the Source, Maintenance and Recoverability (SMR) codes.

**C-2. GENERAL.** In addition to Section I, Introduction, this Repair Parts and Special Tools List is divided into the following sections:

a. *Section II. Repair Parts List.* A list of spares and repair parts authorized by this RPSTL for use in the performance of maintenance. The list also includes parts which must be removed for replacement of the authorized parts. Parts lists are composed of functional groups in ascending alphanumeric sequence, with the parts in each group listed in ascending figure and item number sequence. Bulk materials are listed by item name in FIG. BULK at the end of the section. Repair parts kits are listed separately in their own functional group within section II. Repair parts for repairable special tools are also listed in this section. Items listed are shown on the associated illustration(s)/ figure(s).

b. *Section III. Special Tools List.* Not applicable.

c. *Section IV. National Stock Number and Part Number Index.* A list, in National item identification number (NIIN) sequence, of all National stock numbered items appearing in the listing, followed by a list in alphanumeric sequence of all part numbers appearing in the listings. National stock numbers and part numbers are cross-referenced to each illustration figure and item number appearance.

#### C-3. EXPLANATION OF COLUMNS (SECTIONS II AND III).

a. *ITEM NO. (Column (1)).* Indicates the number used to identify items called out in the illustration.

b. *SMR CODE (Column (2)).* The Source, Maintenance, and Recoverability (SMR) code is a 5-position code containing supply/requisitioning information, maintenance category authorization criteria, and disposition instruction, as shown in the following breakout:

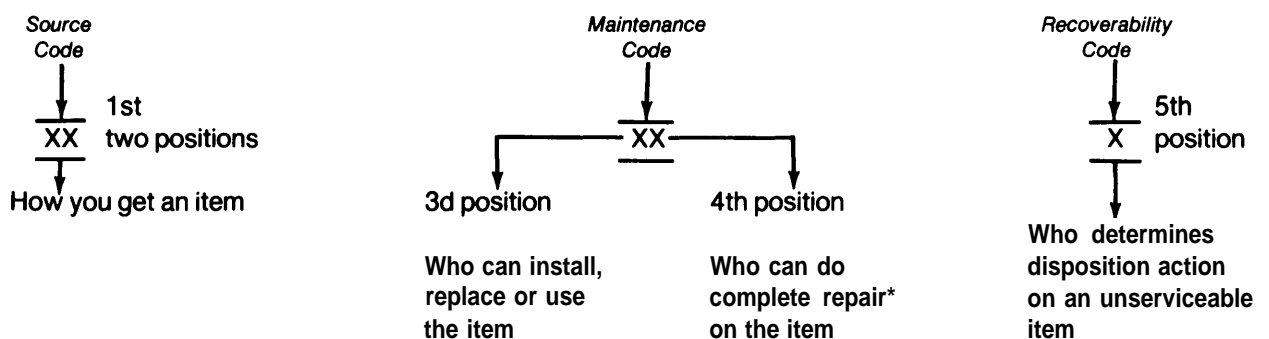

\*Complete Repair: Maintenance capacity, capability, and authority to perform all corrective maintenance tasks of the "Repair" function in a use/user environment in order to restore serviceability to a failed item.



(1) Source code. The source code tells you how you get an item needed for maintenance, repair, or overhaul of an end item/equipment. Explanations of source codes follow:

<i>Code</i>	<i>Explanation</i>
<div style="border: 1px solid black; padding: 5px; display: inline-block;">                     PA                      PB                      PC**                      PD                      PE                      PF                      PG                 </div>	<p>Stocked items; use the applicable NSN to request/requisition items with these source codes. They are authorized to the category indicated by the code entered in the 3d position of the SMR code.</p> <p>**NOTE: Items coded PC are subject to deterioration.</p>
<div style="border: 1px solid black; padding: 5px; display: inline-block;">                     KD                      KF                      KB                 </div>	<p>Items with these codes are not to be requested/requisitioned individually. They are part of a kit which is authorized to the maintenance category indicated in the 3d position of the SMR code. The complete kit must be requisitioned and applied.</p>
<div style="border: 1px solid black; padding: 5px; display: inline-block;"> <b>MO-(Made at Unit/ AVUM Level)</b>  <b>MF-(Made at Intermediate DS/ AVIM Level)</b>  <b>MH-(Made at Intermediate GS Level)</b>  <b>ML-(Made at Specialized Repair Act (SRA))</b>  <b>MD-(Made at Depot)</b> </div>	<p>Items with these codes are not to be requested/requisitioned individually. They must be made from bulk material which is identify by the part number in the DESCRIPTION AND USABLE ON CODE (UOC) column and listed in the bulk material group in the repair parts list in this RPSTL. If the item is authorized to you by the 3d position code of the SMR code, but the source code indicates it is made at a higher level, order the item from the higher level of maintenance.</p>
<div style="border: 1px solid black; padding: 5px; display: inline-block;"> <b>AO-(Assembled by Unit/AVUM Level)</b>  <b>AF-(Assembled by IntermediateDS/ AVIM Level)</b>  <b>AH-(Assembled by Intermediate GS Level)</b>  <b>AL-(Assembled by SRA)</b>  <b>AD-(Assembled by Depot)</b> </div>	<p>Items with these codes are not to be requested/requisitioned individuality. The parts that make up the assembled item must be requisitioned or fabricated and assembled at the level of maintenance indicated by the source code. If the 3d position code of the SMR code authorizes you to replace the item, but the source code indicates the item is assembled at a higher level, order the item from the higher level of maintenance.</p>
<p><b>XA</b> - Do not requisition an "XA"-coded item. Order its next higher assembly. (Also, refer to the NOTE below.)</p> <p><b>XB</b> - If an "XB" item is not available from salvage, order it using the FSCM and part number given.</p> <p><b>XC</b> - Installation drawing, diagram, instruction sheet, field service drawing, that is identified by manufacturer's part number.</p> <p><b>XD</b> - Item is not stocked. Order an "XD" added item through normal supply channels using the FSCM and part number given, if no NSN is available.</p>	

**NOTE**

Cannibalization or controlled exchange, when authorized, may be used as a source of supply for items with the above source codes, except for those source coded "XA" or those aircraft support items restricted by requirements of AR 700-42.

(2) Maintenance code. Maintenance codes tell you the level(s) of maintenance authorized to USE and REPAIR support items. The maintenance codes are entered in the third and fourth positions of the SMR code as follows:

(a) The maintenance code entered in the third position tells you the lowest maintenance level authorized to remove, replace, and use an item. The maintenance code entered in the third position will indicate authorization to one of the following levels of maintenance:

<i>Code</i>	<i>Application/Explanation</i>
C -	Crew or operator maintenance done within unit or aviation unit maintenance.
O -	Unit or aviation unit category can remove, replace, and use the item.
F -	Intermediate direct support or aviation intermediate level can remove, replace, and use the item.
H -	Intermediate general support level can remove, replace, and use the item.
L -	Specialized repair activity can remove, replace, and use the item.
D -	Depot level can remove, replace, and use the item.

(b) The maintenance code entered in the fourth position tells you whether or not the item is to be repaired and identifies the lowest maintenance level with the capability to do complete repair (i.e., perform all authorized repair functions).

**NOTE**

Some limited repair may be done on the item at a lower level of maintenance, if authorized by the Maintenance Allocation Chart (MAC) and SMR codes.

This position will contain one of the following maintenance codes:

<i>Code</i>	<i>Application/Explanation</i>
O -	Unit organizational or aviation unit is the lowest level that can do complete repair of the item.
F -	Intermediate direct support or aviation intermediate is the lowest level that can do complete repair of the item.
H -	Intermediate general support is the lowest level that can do complete repair of the item.
L -	Specialized repair activity (designate the specialized repair activity) is the lowest level that can do complete repair of the item.
D -	Depot is the lowest level that can do complete repair of the item.
Z -	Nonreparable. No repair is authorized.
B -	No repair is authorized. No parts or special tools are authorized for the maintenance of a "B" coded item. However, the item may be reconditioned by adjusting, lubricating, etc., at the user level.

(3) Recoverability code. Recoverability codes are assigned to items to indicate the disposition action on unserviceable items. The recoverability code is entered in the fifth position of the SMR code as follows:

<i>Recoverability Codes</i>	<i>Application/Explanation</i>
Z	- Nonreparable item. When unserviceable, condemn and dispose of the item at the level of maintenance shown in 3d position of SMR code.
O	- Reparable item. When uneconomically reparable, condemn and dispose of the item at unit or aviation unit level.
F	- Reparable item. When uneconomically reparable, condemn and dispose of the item at the intermediate direct support or aviation intermediate level.
H	- Reparable item. When uneconomically reparable, condemn and dispose of the item at the intermediate general support level.
D	- Reparable item. When beyond lower level repair capability, return to depot. Condemnation and disposal of item not authorized below depot level.
L	- Reparable item. Condemnation and disposal not authorized below specialized repair activity (SRA).
A	- Item requires special handling or condemnation procedures because of specific reasons (e.g., precious metal content, high dollar value, critical material, or hazardous material). Refer to appropriate manuals/directives for specific instructions.

c. *FSCM (Column(3))*. The Federal Supply Code for Manufacturer (FSCM) is a 5 digit numeric code which is used to identify the manufacturer, distributor, or Government agency, etc., that supplies the item.

d. *PART NUMBER (Column (4))*. Indicates the primary number used by the manufacturer (individual, company, firm, corporation, or Government activity), which controls the design and characteristics of the item by means of its engineering drawings, specifications standards, and inspection requirements to identify an item or range of items.

**NOTE**

When you use an NSN to requisition an item, the item you receive may have a different part number from the part ordered.

e. *DESCRIPTION AND USABLE ON CODE (UOC) (Column(5))*. This column includes the following information:

- (1) The Federal item name and, when required, a minimum description to identify the item.
- (2) The usable on code, when applicable (see paragraph 5, special information).
- (3) The statement "END OF FIGURE" appears just below the last item description in column 5 for a given figure in both section II and section III.

f. *QTY (Column (6))*. The QTY (quantity per figure column) indicates the quantity of the item used in the breakout shown on the illustration figure, which is prepared for a functional group, subfunctional group, or an assembly. A "V" appearing in this column in lieu of a quantity indicates that the quantity is variable and the quantity may vary from application to application.

**C-4. EXPLANATION OF COLUMNS (SECTION IV).**

a. *NATIONAL STOCK NUMBER (NSN) INDEX.*

(1) STOCK NUMBER column. This column lists the NSN by National item identification number

(NIIN) sequence. The NIIN consists of the last nine digits of the NSN (i.e., **5385-01-574-1476**).

**NIIN**

When using this column to locate an item, ignore the first 4 digits of the NSN. However, the complete NSN should be used when ordering items by stock number.

(2) FIG. column. This column lists the number of the figure where the item is identified/located. The figures are in numerical order in section II and section III.

(3) ITEM column. The item number identifies the item associated with the figure listed in the adjacent FIG. column. This item is also identified by the NSN listed on the same line.

b. *PART NUMBER INDEX.* Part numbers in this index are listed by part number in ascending alphanumeric sequence (i.e., vertical arrangement of letter and number combination which places the first letter or digit of each group in order A through Z, followed by the numbers O through 9 and each following letter or digit in like order).

(1) FSCM column. The Federal Supply Code for Manufacturer (FSCM) is a 5 digit numeric code used to identify the manufacturer, distributor, or Government agency, etc., that supplies the item.

(2) PART NUMBER column. Indicates the primary number used by the manufacturer (individual, firm, corporation, or Government activity), which controls the design and characteristics of the item by means of its engineering drawings, specifications standards, and inspection requirements to identify an item or range of items.

(3) STOCK NUMBER column. This column lists the NSN for the associated part number and manufacturer identified in the PART NUMBER and FSCM columns to the left.

(4) FIG. column. This column lists the number of the figure where the item is identified/located in sections II and III.

(5) ITEM column. The item number is that number assigned to the item as it appears in the figure referenced in the adjacent figure number column.

**C-5. SPECIAL INFORMATION.**

a. *Usable on Code.* The usable on code appears in the lower left corner of the DESCRIPTION column heading. Usable on codes are shown as "UOC: . . . . ." in DESCRIPTION column (justified left) on the first line applicable item description/nomenclature. Uncoded items are applicable to all models. Identification of the usable on codes used in the RPSTL are:

<i>Code</i>	<i>Used On</i>
09A, 09B, 309	M17
410, 10A, 10B, 10C	M17A1
Y08, 08A, 08B, 08C	M17A2

**C-6. HOW TO LOCATE REPAIR PARTS.**

a. *When National Stock Number or Part Number is Not Known:*

(1) First. Using the table of contents, determine the assembly group or subassembly group to which the item belongs. This is necessary since figures are prepared for assembly groups and subassembly groups, and listings are divided into the same groups.

(2) Second. Find the figure covering the functional group or subfunctional group to which the item belongs.

(3) Third. Identify the item on the figure and note the item number.

(4) Fourth. Refer to the Repair Parts List for the figure to find the part number for the item number noted on the figure.

(5) Fifth. Refer to the Part Number Index to find the NSN, if assigned.

b. *When National Stock Number or Part Number is Known:*

(1) First. Using the index of National stock numbers and part numbers, find the pertinent National stock number or part number. The NSN index is in National Item Identification Number (NIIN) sequence (see C-4a(1)). The part numbers in the PART NUMBER INDEX are listed in ascending alphanumeric sequence (see C-4b). Both indexes cross-reference you to the illustration figure and item number of the item you are looking for.

(2) Second. After finding the figure and item number, verify that the item is the one you're looking for, then locate the item number in the repair parts list for the figure.

**C-7. ABBREVIATIONS. Not applicable.**



Section II. REPAIR PARTS LIST

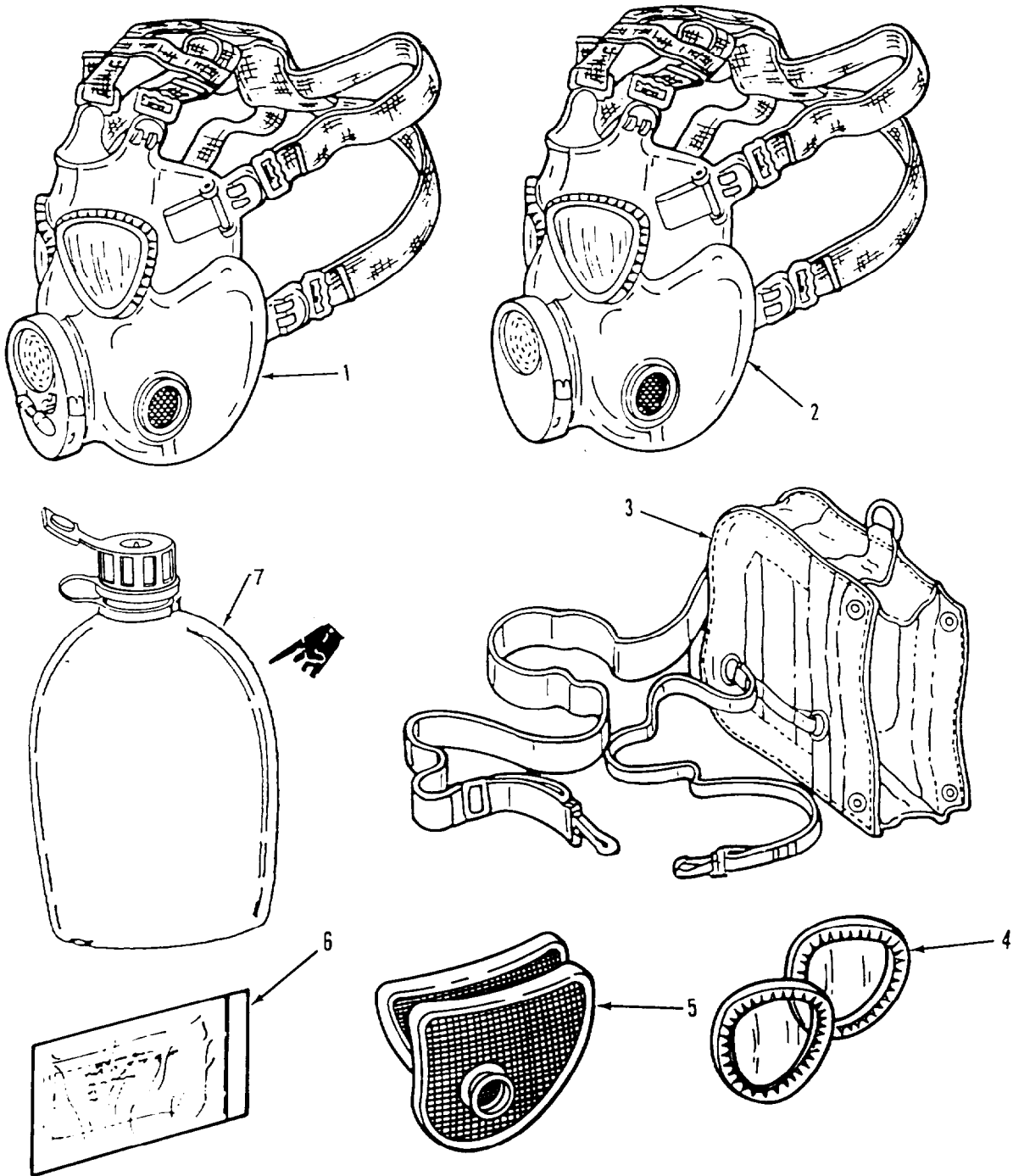

Change 4

Figure C-1. Mask, chemical-biological: M17, M17A1, M17A2

## SECTION II

TM 3-4240-279-20&amp;P

(1) ITEM NO	(2) SMR CODE	(3) FSCM	(4) PART NUMBER	(5) DESCRIPTION AND USABLE ON CODES (UOC)	(6) QTY
GROUP 00 MASKCHEMICAL-BIOLOGICAL: M17 E5-1-293: M17A1 DL5-1-551: M17A2 DL5-1-552					
FIG. C-1 MASK, CHEMICAL-BIOLOGICAL M17, M17A1, AND M17A2					
1	XAODD	81361	E5-1-553	FACEPIECE ASSEMBLY (M17A1 ONLY) UOC: 10A,10B,410	1
1	XAODD	61361	E5-1-874	FACEPIECE ASSEMBLY UOC:Y08,08A,08B,08C	1
2	XAODD	81361	E5-2-948	FACEPIECE ASSEMBLY (M17 ONLY) UOC:09A,09B,309	1
3	PAOZZ	81361	E5-4-400	CARRIER, FIELD CHEMI CB MASK, M15A1	1
4	PAOZZ	81361	5-2-998	OUTSERT, EYELENS	2
5	PCOZA	81361	D5-3-1000	FILTER ELEMENT SET, CB MASK, M13A2	1
7	PAOZZ	81349	MILB51170	BAG, WATERPROOFING, CB MASK, M1	1
6	PACZZ	81349	MIL-C-43103	CANTEEN, WATER W/M1 CAP	1

END OF FIGURE



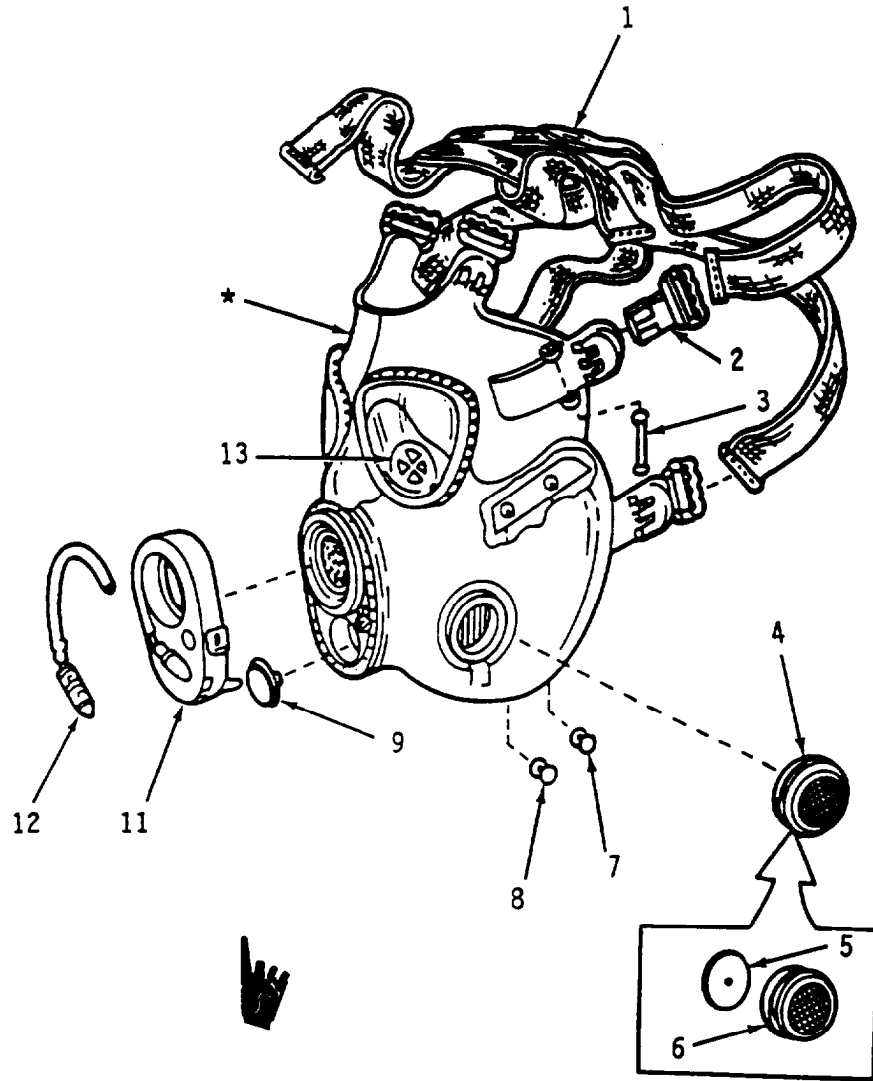

**\*NO FURTHER DISASSEMBLY AUTHORIZED**

SECTION II		TM 3-4240-279-20&P			
(1) ITEM NO	(2) SMR CODE	(3) FSCM	(4) PART NUMBER	(5) DESCRIPTION AND USABLE ON CODES (UOC)	(6) QTY
GROUP 01 FACEPIECE ASSEMBLY M17 E5-2-298: M17A1 E5-1-553: M17A2 E5-1-874					
GROUP 0101 VALVE, INLET C5-2-1014					
FIG. C-2 FACEPIECE ASSEMBY AND INLET VALVE					
1	PAOZZ	81361	D5-2-1661	HARNESS, HEAD..	1
2	PAOZZ	81361	B5-2-962	CLIP AND BUCKLE CML ASSEMBLY	6
3	PAOZZ	81361	A5-2-965	PIN, TEMPLE TEMPLE CML	2
4	PAOOO	81361	C5-2-1014	VALVE, INLET, CHEMICAL	2
5	PAOZZ	81361	85-2-1034	..DISK, VALVE VALVE 14IN. THK 100 PER BAG	4
6	XAOZZ	81361	C5-2-1016	..CAP COVER, INLET VALVE	1
7	PAOZZ	81361	A5-2-956	BUTTON, FLAP, SHORT	2
8	PAOZZ	81361	B5-2-955	BUTTON, FLAP, LONG	2
9	XDOZZ	81361	B5-1-1057	DISK, VALVE OUTLET VALVE	1
10	DELETED				
11	PAOZZ	81361	E5-81-113	COVER, VOICEMITTER-O OUTLET VALVE ASSEMBLY, UOC:Y08,08A,08B,08C,10A,10B,410	1
12	PCOZZ	81361	D5-81-114	COUPLING HALF, QUICK DISCONNECT UOC:Y08,08A,08B,08C,10A,10B,410	1
13	PAOZZ	81361	B5-2-1034	DISK, VALVE 14IN.THK 100 PER BAG	4

END OF FIGURE

### Section III. SPECIAL TOOLS LIST

Not Applicable

C-2-1

Change 4



**SECTION IV**

**TM 3-4240-279-20&P**

**CROSS-REFERENCE INDEXES**

STOCK NUMBER	FIG.	NATIONAL STOCK NUMBER INDEX ITEM	STOCK NUMBER	FIG.	ITEM
4240-00-165-5026	C-1	5			
4240-00-377-9401	C-1	6			
4240-00-602-2207	C-2	2			
5315-00-602-2208	C-2	3			
4240-00-602-2209	C-2	7			
4240-00-602-2210	C-2	8			
4240-00-678-0731	C-1	4			
4240-00-893-3697	C-2	4			
4240-00-903-3606	C-2	11			
4730-00-903-4573	C-2	12			
4240-00-933-2533	C-1	3			
4820-01-104-0965	C-2	5			
	C-2	13			
8465-01-115-0026	C-1	7			
4240-01-223-7313	C-2	1			

## SECTION IV

## TM 3-4240-279-20&amp;P

## CROSS-REFERENCE INDEXES

FSCM	PART NUMBER	PART NUMBER INDEX STOCK NUMBER	FIG.	ITEM
81361	A5-2-956	4240-00-602-2209	C-2	7
81361	A5-2-965	5315-00-602-2208	C-2	3
81361	B5-1-1057		C-2	9
61361	B5-2-1034	4820-01-104-0965	C-2	5
			C-2	13
81361	B5-2-955	4240-00-602-2210	C-2	8
81361	B5-2-962	4240-00-602-2207	C-2	2
81361	C5-2-1014	4240-00-893-3697	C-2	4
81361	C5-2-1016		C-2	6
81361	D5-2-1661	4240-01-223-7313	C-2	1
81361	D5-3-1000	4240-00-165-5026	C-1	5
81361	D5-81-114	4730-00-903-4573	C-2	12
81361	E5-1-553		C-1	1
81361	E5-1-874		C-1	1
81361	E5-2-948		C-1	2
81361	E5-4-400	4240-00-933-2533	C-1	3
81361	E5-81-113	4240-00-903-3606	C-2	11
81349	MIL-C-43103	8465-01-115-0026	C-1	7
81349	MILB51170	4240-00-377-9401	C-1	6
81361	5-2-998	4240-00-678-0731	C-1	4

## SECTION IV

## TM 3-4240-279-20&amp;P

## CROSS-REFERENCE INDEXES

		FIGURE AND ITEM NUMBER INDEX		
FIG.	ITEM	STOCK NUMBER	FSCM	PART NUMBER
C-1	1		81361	E5-1-553
C-1	1		81361	E5-1-874
C-1	2		81361	E5-2-948
C-1	3	4240-00-933-2533	81361	E5-4-400
C-1	4	4240-00-678-0731	81361	5-2-998
C-1	5	4240-00-165-5026	81361	D5-3-1000
C-1	6	4240-00-377-9401	81349	MILB51170
C-1	7	8465-00-115-0026	81349	MIL-C-43103
C-1	1	4240-01-223-7313	81361	05-2-1661
C-1	2	4240-00-602-2207	81361	B5-2-962
C-2	3	5315-00-602-2208	81361	A5-2-965
C-2	4	4240-00-893-3697	81361	C5-2-1014
C-2	5	4820-01-104-0965	81361	B5-2-1034
C-2	6		81361	C5-2-1016
C-2	7	4240-00-602-2209	81361	A5-2-956
C-2	8	4240-00-602-2210	81361	B5-2-955
C-2	9		81361	B5-1-1057
C-2	10	DELETED		
C-2	11	4240-00-903-3606	81361	E5-81-113
C-2	12	4730-00-903-4573	81361	D5-81-114
C-2	13	4820-01-104-0965	81361	B5-2-1034

## APPENDIX D EXPENDABLE/DURABLE SUPPLIES AND MATERIALS LIST

### Section I. INTRODUCTION

**D-1. SCOPE**

This appendix lists expendable/durable supplies and materials you will need to operate and maintain the M17/M17A1/M17A2 mask. This listing is for informational purposes only and is not authority to requisition the listed items. These items are authorized to you by CTA 50-970, Expendable/Durable items (Except Medical, Class V, Repair Parts, and Heraldic items), or CTA 8-100, Army Medical Department Exendable/Durable Items.

**D-2. EXPLANATION OF COLUMNS.**

a. *Column 1 - Item Number.* This number is assigned to the entry in the listing and is referenced in the narrative instructions to identify the material (e.g., "Use cleaning compound (item 8, app D)").

b. *Column 2 - Level.* This column identifies the low-est level of maintenance that requires the listed item.

C-Operator/Crew  
O-Organizational Maintenance

c. *Column 3 - National Stock Number.* This is the National stock number assigned to the item; use it to request or requisition the item.

d. *Column 4 - Description.* indicates the Federal item name and, if required, a description to identify the item. The last line for each item indicates the Federal Supply Code for Manufacturer (FSCM) in parentheses followed by the part numbers.

e. *Column 5- Unit of Measure (U/M).* Indicates the measure used in performing the actual maintenance function. This measure is expressed by a two-character alphabetical abbreviation (e.g., ea, in., pr). if the unit of measure differs from the unit of issue, requisition the lowest unit of issue that will satisfy your requirements.

### Section II. EXPENDABLE/DURABLE SUPPLIES AND MATERIALS LIST

(1) ITEM NUMBER	(2) LEVEL	(3) NATIONAL STOCK NUMBER	(4) DESCRIPTION	(5) U / M
1	O	6515-00-303-8250	APPLICATOR, DISPOSABLE: plastic or wood, cotton tipped, 6.00 x 0.08 in. (15.24 x 0.21 cm) (81348) GG-A-616	EA
2	O	7920-00-514-2417	BRUSH, ACID SWABBING: bristle and horsehair, metal handle, type 2, class 1 (81348) H-B-643	GR
3	C	1005-00-494-6602	BRUSH, CLEANING, SMALL (19204) 8448462	EA
4	C	7920-00-205-0565	BRUSH, DUSTING, LENS AND PHOTOGRAPHIC NEGATIVE: camel's hair, wood handle (81348) H-B-1654	EA
5	C	7920-00-061-0037	BRUSH, SCRUB (81348) H-B-1490	EA

(1) ITEM NUMBER	(2) LEVEL	(3) NATIONAL STOCK NUMBER	(4) DESCRIPTION	(5) U/M
6	O	6665-00-978-5516	BULB, ASPIRATOR: (40912)B-H-5607	EA
7	O	6810-00-242-4770	CALCIUM HYPOCHLORITE, TECHNICAL: granular: 45 lb. box. (12 ea 3-3/4 lb. bt) (81348) O-C-14	LB
	O	6810-00-255-0471	6 oz BT	OZ
	O	6810-00-238-8115	5 lb BT	LB
8	O	5210-00-229-3049	CALIPER, OUTSIDE (81348) GGG-C-95	EA
8A	C	3465-01-115-0026	CANTEEN, WATER, with M1 Cap (81349) MIL-C-43103	EA
9	C	6850-00-592-3283	CLEANING COMPOUND, OPTICAL LENS: liquid (04019) LENSWICK	DZ
10	C	8305-00-222-2423	CLOTH, CHEESECLOTH: cotton basic, type 1, class 1 (81348) CCC-C-440	YD
11	O	8415-00-926-6696	GLOVES, Chemical and Oil (81348) ZZ-G-381	PR
12	C	6505-00-655-8366	ISOPROPYL RUBBING ALCOHOL: bottle, plastic container 1 pt bottle (56287) PUREPAC	PT
13	O	5110-00-162-2205	KNIFE, POCKET (71332) 6400445R	EA
14	O	8010-00-085-0559	LACQUER: No. 4 black, brushing, 4.0 oz (133.49) (133.49) (19139) 4 1 oz BT	OZ
15	O	6810-00-123-7047	n-AMYLACETATE, REAGENT, clear, flammable liquid (81349) MIL-C-51130	PT
16	C	7240-01-094-4305	PAIL, UTILITY: plastic, snap-on lid, 5.00 gal. (18.93 1) (58536) A-A-332	EA
17	O	6850-00-161-6203	PAINT, FACE, CAMOUFLAGE (81349) MILP2018	EA
18	C	7930-00-935-3794	POLISH, PLASTIC: liquid, type 1 (81348) P-P-560 24 ea bx	EA



(1) ITEM NUMBER	(2) LEVEL	(3) NATIONAL STOCK NUMBER	(4) DESCRIPTION CAGEC AND PART NUMBER	(5) U/M
19	C	8520-00-228-0598	SOAP, TOILET (81348) P-S-624 (or equivalent)	GL
20	O	7330-00-875-6912	SPOON, MEASURING (09788) 832977	EA
21	O	6665-00-928-5731	TUBE, SMOKE (55799) BH5645	EA
22	O	8135-00-116-1443	CUSHIONING MATERIAL (81349) MIL-P-26514	FT
23	O	7510-00-159-4450	TAPE, PRESSURE SENSITIVE (81348) PPP-T-0097	YD
24	C	4240-01-372-3078	WIPES, RESPIRATOR, CLEANING (50378) 504	EA

## APPENDIX E

### ILLUSTRATED LIST OF MANUFACTURED ITEMS

#### E-1. INTRODUCTION.

This appendix includes complete instructions for making the item authorized to be manufactured or fabricated at organizational maintenance. The bulk material for manufacture of the item is listed by part number or specification number on the illustration.

#### E-2. FABRICATING INSTRUCTIONS.

The thumbsaver, used by unit maintenance personnel to remove the inlet valve, is fabricated from an aluminum alloy metal sheet. The front end of its head should be formed so it will clear the center of the inlet valve. Fabricate from the following illustration.

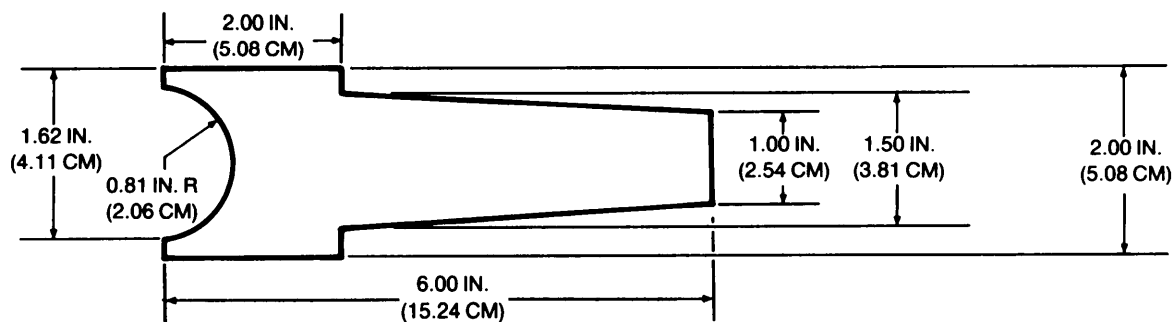

#### NOTES

1. FABRICATE FROM ALUMINUM ALLOY NSN 9530-00-542-2588.
2. THE FLAT STOCK ALUMINUM ALLOY IS 0.125 INCH (0.318 CM) THICK.
3. BE SURE THE THUMBSAVER IS FREE OF SHARP EDGES OR BURRS.

*Figure E-1. Thumbsaver*

## ALPHABETICAL INDEX

<i>Subject</i>	<i>Page</i>	<i>Subject</i>	<i>Page</i>
<b>A</b>		<b>F</b>	
Adjusting Facepiec at Initial Fitting . . . . .	2-3	Faceblank, Location and Description . . . . .	1-2
Appendix A, References . . . . .	A-1	Facepiece Assembly:	
Appendix B, Maintenance Allocation Chart . . . . .	B-1	Location and Description . . . . .	1-2
Appendix C, Repair Parts and Special Tools List . . . . .	C-1	Maintenance Instructions . . . . .	2-28
Appendix D, Expendable/Durable Supplies and Materials List . . . . .	D-1	Features, Equipment Characteristics, and Capabilities . . . . .	1-1
Appendix E, Illustrated List of Manufactured Items . . . . .	E-1	Filter Elements:	
		Location and Description . . . . .	1-4
		Replacement Criteria . . . . .	2-23
		Flap Buttons (Short and Long):	
		Location and Description . . . . .	1-4
		Replacement . . . . .	2-32
<b>C</b>		<b>G</b>	
█ Canteen, Water with M1Cap . . . . .	2-22.1	General Information . . . . .	1-1
Capabilities, Features, and Equipment Characteristics . . . . .	1-1		
Carrier, M15A1:			
Cleaning . . . . .	2-49		
Location and Description . . . . .	1-7		
Checking Facepiece for Leaks . . . . .	2-24		
Cleaning and Sanitizing (Mask) . . . . .	2-46		
Clip and Buckle Assembly:			
Location and Description . . . . .	1-4		
Replacement . . . . .	2-29		
Common Tools and Equipment . . . . .	2-1		
Crimping Rings, Location and Description . . . . .	1-3		
<b>D</b>		<b>H</b>	
Desctruction of Army Materiel to Prevent Enemy Use . . . . .	1-1	Head Harness:	
Differences Between Models . . . . .	1-8	Location and Description . . . . .	1-3
		Replacement . . . . .	2-28
<b>E</b>		<b>I</b>	
EIR's, Reporting Equipment Improvement Recommendations . . . . .	1-1	Illustrated List of Manufactured Items, Appendix E . . . . .	E-1
Equipment Characteristics, Capabilities, and Features . . . . .	1-1	Inlet Valves, Location and Description . . . . .	1-4
Equipment Data . . . . .	1-8		
Equipment Description and Data . . . . .	1-1		
Expendable/Durable Supplies and Materials List . . . . .	D-1		
Eyelens Outserts, Location and Description . . . . .	1-7		
		<b>L</b>	
		Location and Description of: Major Components . . . . .	1-2
		<b>M</b>	
		Maintenance Allocation Chart For M17/M17A1/M17A2 Mask . . . . .	B-1
		Maintenance Forms, Records, and Reports...	1-1
		Maintenance Procedures (See individual part or assembly) . . . . .	2-27
		M15A1 Carrier:	
		Cleaning . . . . .	2-49
		Location and Description . . . . .	1-7

<b>Subject</b>	<b>Page</b>	<b>Subject</b>	<b>Page</b>
<b>M (Cont)</b>		<b>R (Cont)</b>	
M17/M17A1/M17A2 Mask:		Repair Parts, Special Tools, TMDE, and	
Adjusting Facepiece at Initial Fitting.....	2-3	Support Equipment .....	2-1
Checking Facepiece for Leaks.....	2-24	Replacement Criteria, Filter Elements .....	2-23
Cleaning and Sanitizing Mask.....	2-46	Reporting Equipment Improvement	
Maintenance Procedures.....	2-27	Recommendations (EIR's).....	1-1
Service Upon Receipt.. .....	2-1	Reporting Errors and Recommending	
		Improvements .....	1-1
<b>N</b>		Reports, Maintenance Forms, and Records...	1-1
National Stock Number and Part Number		<b>S</b>	
Index .....	1-1	Sanitizing, Cleaning (Masks). .....	2-46
Nosecup Assembly, Location and		Service Upon Receipt.. .....	2-1
Description .....	1-5	Special Tools List.....	Bulk-1
<b>O</b>		Special Tools, TMDE, Repair Parts, and	
Outlet Valve, Location and		Support Equipment.. .....	2-1
Description .....	1-6	Support Equipment, TMDE, Special Tools	
<b>P</b>		and Repair Parts.. .....	2-1
PMCS (See preventive maintenance checks		<b>T</b>	
and services) .....	2-11	Temple Pin:	
Preparation for Storage or Shipment . . . . .	2-52	Location and Description.. .....	1-4
Prevent Enemy Use, Destruction of		Replacement.....	2-31
Army Materiel to.....	1-1	Thumbsaver, Fabricating Instructions.. .....	E-1
Preventive Maintenance Checks and		TMDE, Support Equipment, Repair Parts,	
Services (PMCS)		and Special Tools.. .....	2-1
<b>Q</b>		Tools and Equipment, Common .....	2-1
Quick Disconnect Coupling Half,		<b>V</b>	
Voicemitter-Outlet Valve.....	1-6	Voicemitter, Location and Description. . . . .	1-6
Assembly Clover Replacement .....	2-38	Voicemitter-Outlet Valve Assembly,	
<b>R</b>		Location and Description.....	1-6
Records, Reports, and Maintenance Forms.....	1-1	Voicemitter-Outlet Valve Assembly Cover:	
References, Appendix A.....	A-1	Location and Description . . . . .	1-6
Remarks, Maintenance Allocation Chart.....	B-3	Replacement .....	2-38
Repair Parts.. .....	C-1-1	<b>W</b>	
Repair Parts and Special Tools List,		Warning Page .....	a
Appendix C .....	C-1	Waterproof Bag, MI, Location and	
Repair Parts List.....	C-1-1	Description .....	1-8

By Order of the Secretary of the Army:

CARL E. VUONO  
*General, United States Army*  
*Chief of Staff*

Official:

R. L. DILWORTH  
*Brigadier General, United States Army*  
*The Adjutant General*

Distribution:

To be distributed in accordance with DA Form 12-28, United Maintenance Including Repair Parts and Special Tools List for Field Mask.

\*U. S. GOVERNMENT PRINTING OFFICE: 1988-543-145

RECOMMENDED CHANGES TO EQUIPMENT TECHNICAL PUBLICATIONS



THEN... JOT DOWN THE DOPE ABOUT IT ON THIS FORM. CAREFULLY TEAR IT OUT, FOLD IT AND DROP IT IN THE MAIL!

## SOMETHING WRONG WITH THIS PUBLICATION?

FROM: (PRINT YOUR UNIT'S COMPLETE ADDRESS)

DATE SENT

PUBLICATION NUMBER <b>TM 3-4240-279-20&amp;P</b>	PUBLICATION DATE <b>11 Oct 95</b>	PUBLICATION TITLE <b>M17, M17A1, M17A2 Chemical-Biological Field Mask</b>
---	--------------------------------------	--

BE EXACT... PIN-POINT WHERE IT IS				IN THIS SPACE TELL WHAT IS WRONG AND WHAT SHOULD BE DONE ABOUT IT:
PAGE NO.	PARA-GRAPH	FIGURE NO.	TABLE NO.	

TEAR ALONG DOTTED LINE

PRINTED NAME, GRADE OR TITLE, AND TELEPHONE NUMBER	SIGN HERE
--	-----------

FILL IN YOUR  
UNITS ADDRESS



DEPARTMENT OF THE ARMY

OFFICIAL BUSINESS



NO POSTAGE  
NECESSARY  
IF MAILED  
IN THE  
UNITED STATES

**BUSINESS REPLY MAIL**  
FIRST CLASS      PERMIT NO. 82      ROCK ISLAND IL

POSTAGE WILL BE PAID BY ROCK ISLAND ARSENAL

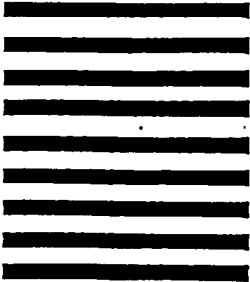

DIRECTOR  
ARMAMENT AND CHEMICAL ACQUISITION  
AND LOGISTICS ACTIVITY  
ATTN: AMSTA-AC-MAS  
ROCK ISLAND IL 61201-9948

TEAR ALONG PERFORATED LINE



## THE METRIC SYSTEM AND EQUIVALENTS

### LINEAR MEASURE

1 Centimeter = 10 Millimeters = 0.01 Meter = 0.3937 Inch  
 1 Decimeter = 10 Centimeters = 3.94 Inches  
 1 Meter = 10 Decimeters = 100 Centimeters  
           = 1000 Millimeters = 39.37 Inches  
 1 Dekameter = 10 Meters = 32.8 Feet  
 1 Hectometer = 10 Dekameters = 328.08 Feet  
 1 Kilometer = 10 Hectometers = 1000 Meters  
               = 0.621 Mile = 3,280.8 Feet  
 Millimeters = Inches times 25.4  
 Inches = Millimeters divided by 25.4

### WEIGHTS

1 Centigram = 10 Milligrams = 0.154 Grain  
 1 Decigram = 10 Centigrams = 1.543 Grains  
 1 Gram = 0.001 Kilogram = 10 Decigrams  
           = 1000 Milligrams = 0.035 Ounce  
 1 Dekagram = 10 Grams = 0.353 Ounce  
 1 Hectogram = 10 Dekagrams = 3.527 Ounces  
 1 Kilogram = 10 Hectograms = 1000 Grams = 2.205 Pounds  
 1 Quintal = 100 Kilograms = 220.46 Pounds  
 1 Metric Ton = 10 Quintals = 1000 Kilograms = 1.102 Short Tons

### LIQUID MEASURE

1 Milliliter = 0.001 Liter = 0.034 Fluid Ounce  
 1 Centiliter = 10 Milliliters = 0.34 Fluid Ounce  
 1 Deciliter = 10 Centiliters = 3.38 Fluid Ounces  
 1 Liter = 10 Deciliters = 1000 Milliliters = 33.82 Fluid Ounces  
 1 Dekaliter = 10 Liters = 2.64 Gallons  
 1 Hectoliter = 10 Dekaliters = 26.42 Gallons  
 1 Kiloliter = 10 Hectoliters = 264.18 Gallons

### SQUARE MEASURE

1 Sq Centimeter = 100 Sq Millimeters = 0.155 Sq Inch  
 1 Sq Decimeter = 100 Sq Centimeters = 15.5 Sq Inches  
 1 Sq Meter (Centare) = 100 Sq Decimeters  
                               = 10,000 Sq Centimeters = 10.764 Sq Feet  
 1 Sq Dekameter (Are) = 100 Sq Meters = 1,076.4 Sq Feet  
 1 Sq Hectometer (Hectare) = 100 Sq Dekameters = 2.471 Acres  
 1 Sq Kilometer = 100 Sq Hectometers = 1,000,000 Sq Meters  
                       = 0.386 Sq Mile

### CUBIC MEASURE

1 Cu Centimeter = 1000 Cu Millimeters = 0.061 Cu Inch  
 1 Cu Decimeter = 1000 Cu Centimeters = 61.02 Cu Inches  
 1 Cu Meter = 1000 Cu Decimeters = 1,000,000 Cu Centimeters  
                   = 35.31 Cu Feet

### TEMPERATURE

5/9 (°F - 32°) = °C  
 9/5 (°C + 32°) = °F  
 -35° Fahrenheit is equivalent to -37° Celsius  
 0° Fahrenheit is equivalent to -18° Celsius  
 32° Fahrenheit is equivalent to 0° Celsius  
 90° Fahrenheit is equivalent to 32.2° Celsius  
 100° Fahrenheit is equivalent to 38° Celsius  
 212° Fahrenheit is equivalent to 100° Celsius

## APPROXIMATE CONVERSION FACTORS

<u>TO CHANGE</u>	<u>TO</u>	<u>MULTIPLY BY</u>	<u>TO CHANGE</u>	<u>TO</u>	<u>MULTIPLY BY</u>
Inches	Centimeters	2.540	Meters	Feet	3.281
Feet	Meters	0.305	Meters	Yards	1.094
Yards	Meters	0.914	Kilometers	Miles	0.621
Miles	Kilometers	1.609	Square Centimeters	Square Inches	0.155
Square Inches	Square Centimeters	6.452	Square Meters	Square Feet	10.764
Square Feet	Square Meters	0.093	Square Meters	Square Yards	1.196
Square Yards	Square Meters	0.836	Square Kilometers	Square Miles	0.386
Square Miles	Square Kilometers	2.590	Square Hectometers	Acres	2.471
Acres	Square Hectometers	0.405	Cubic Meters	Cubic Feet	35.315
Cubic Feet	Cubic Meters	0.028	Cubic Meters	Cubic Yards	1.308
Cubic Yards	Cubic Meters	0.765	Milliliters	Fluid Ounces	0.034
Fluid Ounces	Milliliters	29.574	Liters	Pints	2.113
Pints	Liters	0.473	Liters	Quarts	1.057
Quarts	Liters	0.946	Liters	Gallons	0.264
Gallons	Liters	3.785	Grams	Ounces	0.035
Ounces	Grams	28.350	Kilograms	Pounds	2.205
Pounds	Kilograms	0.454	Metric Tons	Short Tons	1.102
Short Tons	Metric Tons	0.907	Newton-Meters	Pound-Feet	0.738
Pound-Feet	Newton-Meters	1.356	Kilopascals	Pounds per Square Inch	0.145
Pounds-Inches	Newton-Meters	0.11298	Kilometers per Liter	Miles per Gallon	2.352
Pounds per Square Inch	Kilopascals	6.895	Kilometers per Hour	Miles per Hour	0.621
Ounce-Inches	Newton-Meters	0.007062	° Fahrenheit	° Celsius	° C = (° F - 32) x 5/9
Miles per Gallon	Kilometers per Liter	0.425	° Celsius	° Fahrenheit	° F = (9/5 x ° C) + 32
Miles per Hour	Kilometers per Hour	1.609			
Centimeters	Inches	0.394			



# MEASURING SCALES FOR MASK SIZING TOOL

## WARNING

DO NOT REPRODUCE MEASURING SCALES. Reproduced copies will not be accurate for measuring purposes.

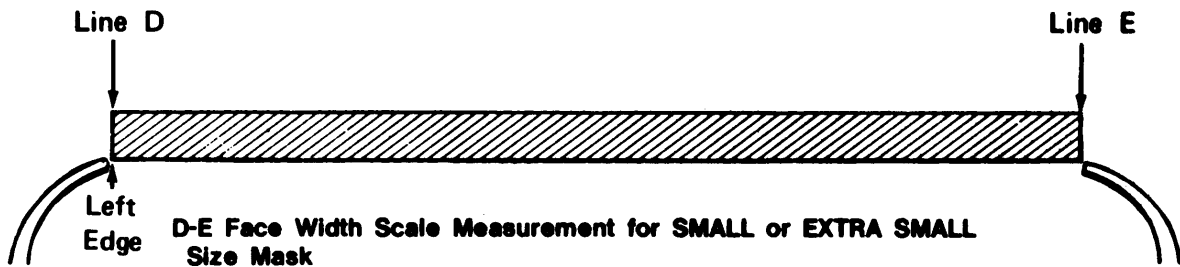
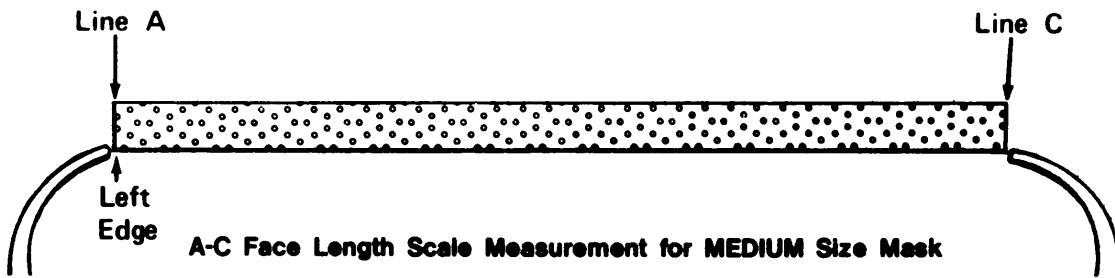
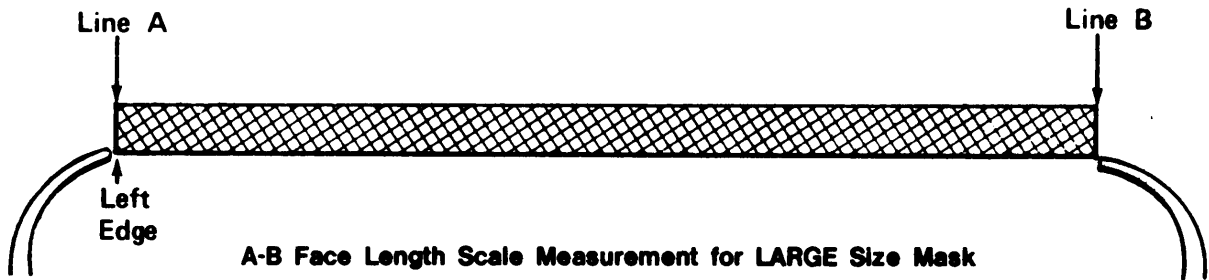

**DO NOT REPRODUCE MEASURING SCALES**

