

Engineering of Beam Direct Conversion for a 120-kV, 1-MW Ion Beam

By William L. Barr, James N. Doggett, Gordon W. Hamilton, John D. Kinney, and Ralph W. Moir; Lawrence Livermore Laboratory, University of California

Work performed under the auspices of the U.S. Energy Research and Development Administration under contract W-7405-Eng-48.

Contact information as of 2009 for Ralph Moir is Vallecitos Molten Salt Research, <RMoir@Pacbell.net>, 607 East Vallecitos Road, Livermore, CA 94550.

Summary

Practical systems for beam direct conversion are required to recover the energy from ion beams at high efficiency and at very high beam power densities in the environment of a high-power, neutral-injection system. Such an experiment is now in progress using a 120-kV beam with a maximum total current of 20 A. After neutralization, the H^+ component to be recovered will have a power of approximately 1 MW. A system testing these concepts has been designed and tested at 15 kV, 2 kW in preparation for the full-power tests. The engineering (problems involved in the full-power tests affect electron suppression, gas pumping, voltage holding, diagnostics, and measurement conditions. Planning for future experiments at higher power includes the use of cryopumping and electron suppression by a magnetic field rather than by an electrostatic field. Beam direct conversion for large fusion experiments and reactors will save millions of dollars in the cost of power supplies and electricity and will dispose of the charged beam under conditions that may not be possible by other techniques.

Introduction

A beam direct converter recovers electrical power by converting the kinetic energy of an ion beam to electrostatic potential energy. Such a converter in a high-power, neutral-injection system will save electrical power by improving the overall efficiency, will save the capital cost of ion-source power supplies, and will eliminate the need for high-power beam dumps by decelerating the charged beam before it is dumped on a target. These considerations are especially important for neutral injection in the energy range above 100 keV because of the

low efficiency of neutral atom production from positive ions in this range of energy.

To be useful in a large fusion experiment or in a reactor, a beam direct converter must be capable of operating continuously at high efficiency and high power density in a compact apparatus. In such an apparatus now being developed we are using a 120 keV ion beam that has a maximum total current of 15 A.¹

The physics design is based upon computations and tests in a smaller system at energies up to 15 keV and beam powers up to 2 kW.² Some of the areas of engineering problems involved in these tests are electron suppression, gas pumping, voltage holding, diagnostics, and heat transport.

Operation of a Beam Direct Converter

A side view of an in-line, space-charge controlled, beam direct converter is shown in Figure 1. In this version, the neutralizing gas cell is at ground potential, the collection electrode is at positive high voltage V^+ (100 to 110 kV), and the electrons produced in the neutralizing cell are repelled by negative voltages V^- (-20 kV) applied by electron repellers before and after the positive collector.

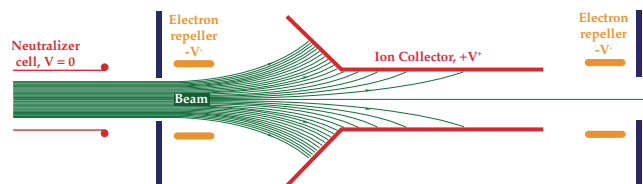

Figure 1 — Space-charge-controlled beam direct converter. In this version, the neutralizing cell is at ground potential and the potentials of the positive and negative electrodes are $+V^+$ and $-V^-$, respectively

The charged beam begins to diverge (blow up) because of its own space charge when the electrons are suppressed. The beam blowup becomes more pronounced as the beam is decelerated because of the increase in space-charge density. Under optimized conditions, 90% or more of the charged beam is collected at positive high voltage. Trajectory computations² indicate that a

small fraction of the charged beam is lost either by transmission through the collector or by reflection from the collector entrance. This fraction depends upon the collector potential and the beam density.

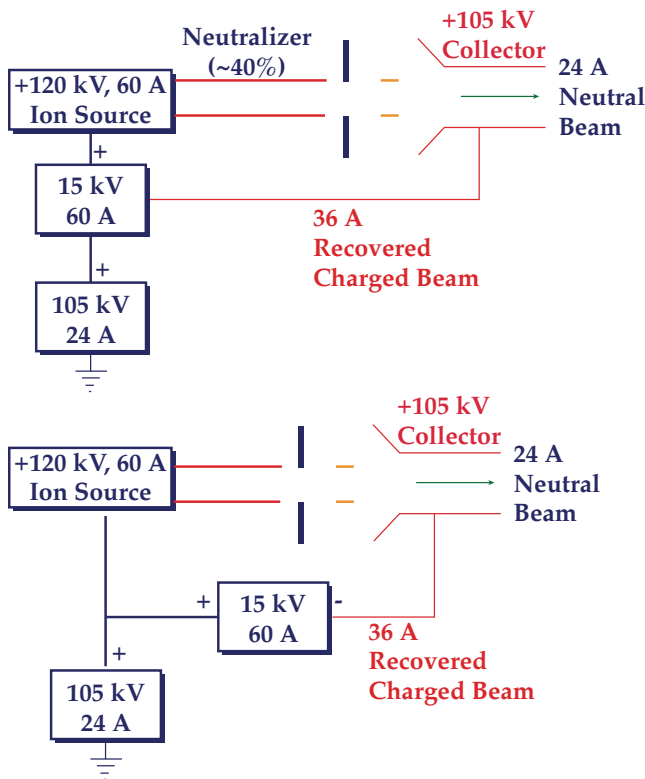

Figure 2 — Two examples of circuits to recirculate the recovered energy to supplement the acceleration power supply of ion sources for a device such as TFTR. In both designs, the total power supply requirement is 4.15 MW, assuming 40% neutralization efficiency for 120-kV D⁺. Compared to the total beam requirement of 60 A at 120 kV, the gross saving in acceleration power supplies is 3.05 MW (assuming 70% overall efficiency of beam direct conversion).

The electrical power recovered by the collector can be either dissipated in a load resistor or fed back to the ion source to supplement the acceleration power supply. For simplicity, we are using various types of load resistors in our present experiments. Figure 2 shows two examples of power-supply systems that could feed back the recovered energy to supplement the high-voltage power supplies for the ion source. These power supplies, which may be the most expensive components of the injection system, could thereby be upgraded to extract a total beam perhaps twice as large as the current capacity of the rectifiers without direct conversion. Beam-energy recovery could therefore be used either to economize on the capital cost of power supplies or to increase the total beam using existing power supplies.

If we assume that the overall efficiency of charged-beam energy recovery is 70% and the neutralization efficiency is 40%, the total power-supply requirement in each of

the examples of Figure 2 [based on Tokamak Fusion Test Reactor (TFTR) requirements] is 4.15 MW. Because of its higher neutralization efficiency, the half-energy charged beam will be not more than 10 to 20%. This effect is included in the 70% overall efficiency of direct conversion, and is not otherwise indicated in the simplified diagrams of Figure 2. In comparison with the total beam power of 7.2 MW, these examples represent a saving of 3.05 Mw for each injector, each of which supplies 2.9 MW of neutral-beam power.

Electron Suppression

For an intense ion beam to propagate, the space charge of the ions must be neutralized. Otherwise, the mutual repulsion of the ions will cause the beam to diverge. Space charge is usually neutralized by allowing the beam to produce the necessary electrons by ionization of the background gas. These electrons must be prevented from entering the direct converter for two reasons: First, if they reach the ion collector, their electrical current would cancel an equal amount of ion current. Second, electrons must not be allowed to neutralize the space charge of the ions inside the direct converter because this would prevent the ions from being deflected out of the beam and onto the collector electrode.

One way to suppress the electrons in the beam is to provide an electrostatic potential barrier. To do this, a negative voltage is applied to an electrode that fits closely around the beam. The voltage must be great enough to drive the potential negative even on the axis in the presence of the positive-ion space charge and the nearby positive-ion collector. The required voltage increases linearly with ion current density and roughly as the square of the beam thickness. We calculate that -20 kV is needed to suppress the electrons in the 15 A, 120 keV hydrogen beam at Lawrence Berkeley Laboratory (LBL).

Another way to suppress electrons is with a magnetic field of the proper strength and extent. Because the momentum of the electrons is much less than that of the ions, a magnetic field can be designed to stop the electrons without significantly affecting the ions. However, the positive collector tends to attract the electrons, causing them to drift across the magnetic field while diffusing toward the collector. Complicated electron motion can result, and the observed electron current indicates the existence of long-lived electrons that are efficient ionizers. The advantage of magnetic suppression (if it can be made to work) is that it can penetrate beams that are too thick and too dense for electrostatic suppression to work.

15-keV Experiment

We have tested a beam direct converter with electrostatic electron suppression at hydrogen ion beam energies up to 15 keV.² A MATS-III ion source³ was modified to produce a slab beam 15 mm thick by 60 mm wide. (Our computer simulation used slab geometry.) To be effective with ion currents up to 130 mA, the suppressor electrodes had to be held at -3 kV.

Figure 3 shows the device. The electrodes were formed from sheet molybdenum and heliarc welded in spots. Although brittle, the welds have survived multiple cycling to white-hot temperature. The radiatively cooled electrodes give a visual indication of the efficiency of the direct converter: when the voltages are set for low electrical efficiency, most of the power appears as heat. At the optimum settings, the efficiency is about 70% and the electrodes remain relatively cool. The pressure is about 5×10^{-5} torr of H₂, and the loss of efficiency due to ionization of gas is about 15%.

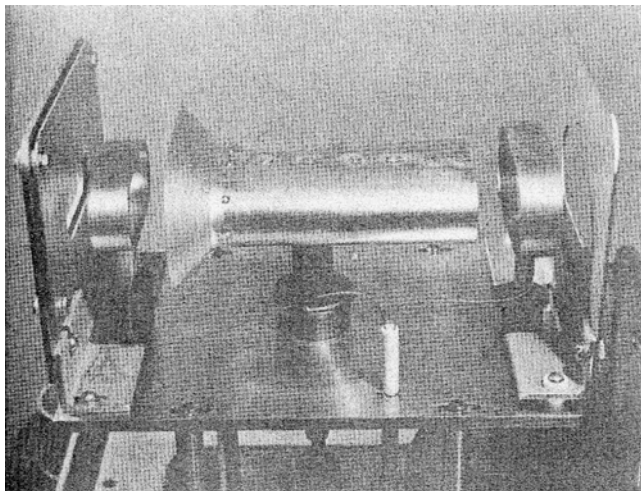

Figure 3 — A radiation-cooled, beam direct converter, operated at 15 kV and recovering 2 kW of energy. The electrodes are made of molybdenum

Magnetic Suppression of Electrons

The limits on beam density and thickness imposed by electrostatic electron suppression could be relaxed if the electrons could be magnetically suppressed.

(This idea was tried unsuccessfully at LLL in 1970 and subsequently independently suggested by O. B. Morgan of ORNL in 1977.)

We are using our 15-keV facility to test different magnetic field configurations. In one approach, an iron yoke and narrow pole pieces (see Figure 4) are used to produce a localized field perpendicular to the beam. Figure 5(a) shows the location of the magnet relative to the collector. A plot of the magnetic field strength on the beam axis is shown in Figure 5(b). We find that a field of

about 300 G is needed to stop the electrons when the collector is biased positively.

However, only a slight blowup of the beam occurs after the magnet, indicating that enough new electrons are produced to neutralize the space charge. A net direct recovery efficiency of about 50% can be obtained by increasing the magnetic field until the ions are deflected onto the side walls of the collector.

In an effort to eliminate the regions where electrons could become trapped, we are also testing the axially symmetrical configuration shown in Figure 6(a). The magnetic field, plotted in Figure 6(b), is produced by the oblong-shaped coil with an iron outer shield that encircles the beam. In the preliminary test of this system, we observed only a slight space-charge blowup of the beam.

Gas-Pressure Requirements for Efficient Direct Conversion

The most critical gas-pressure requirement placed on a direct conversion system is imposed by the power load resulting from the acceleration and collection of the slow ions and electrons produced by ionization and charge exchange of the background gas. The resulting emission of secondary electrons at negative high voltage must also be considered. Other gas-pressure considerations such as voltage-holding requirements are less critical than the power load.

The power load due to the above effects must be negligible compared to the power of the charged beam I^+V^+ , where the energy of the charged beam is almost equal to the positive electrode voltage V^+ . If an ion-electron pair produced by ionization of a gas molecule is accelerated to a total energy of $(V^+ + V^-)$, the power load P_{loss} will be:

$$P_{loss} = \left[I^+ n_{gas} L (\sigma_{i0} + \sigma_{ion,+}) + I^0 n_{gas} L \sigma_{ion,0} \right] \times (V^+ + V^-) (1 + \gamma) \quad (1)$$

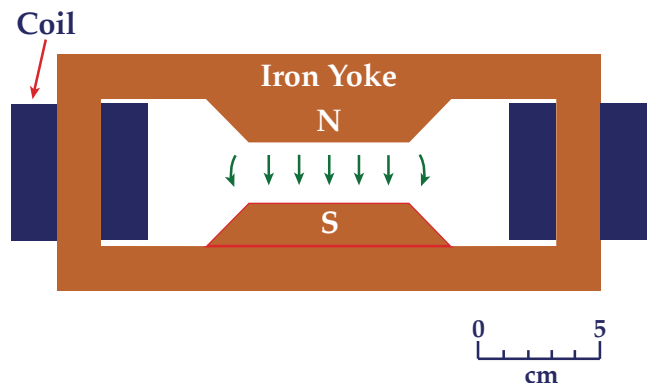

Figure 4 — The magnet used to produce a field perpendicular to the beam for magnetic electron suppression.

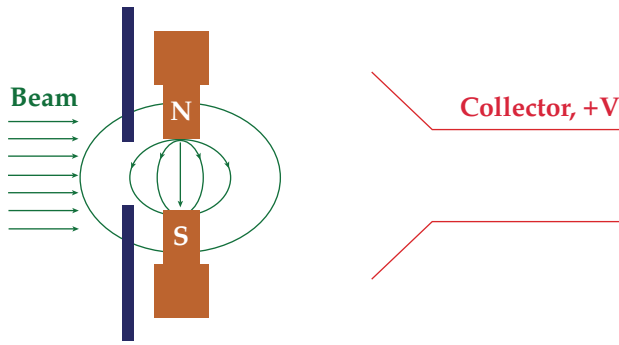

Figure 5(a) — The beam direct converter with a perpendicular field to suppress the electrons

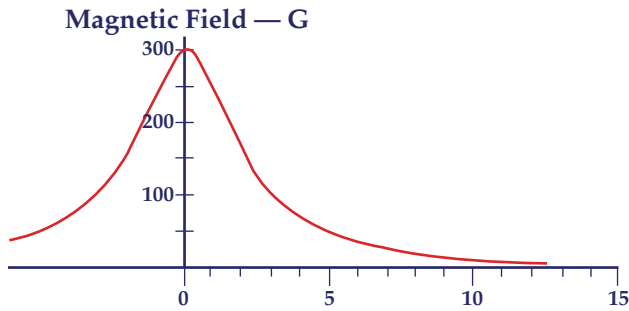

Figure 5(b) — Field strength along the axis

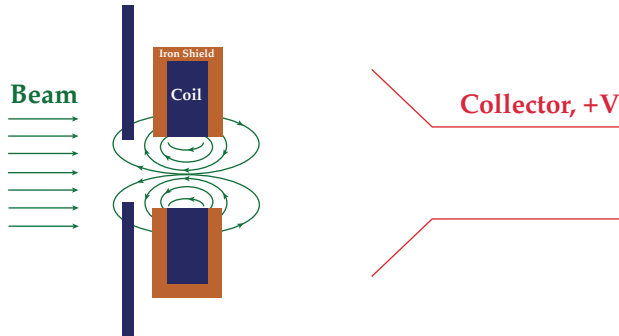

Figure 6(a) — Beam direct converter with a symmetrical magnetic electron suppressor.

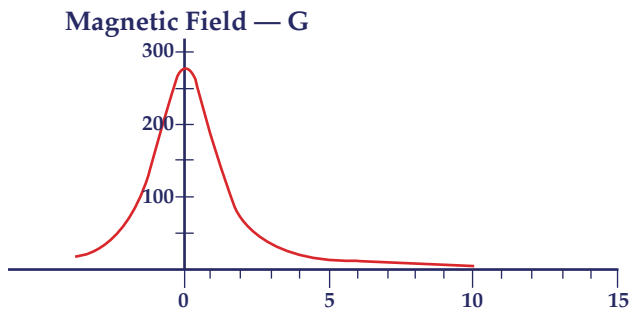

Figure 6(b) — Field strength along the axis.

where n_{gas} is the background gas density, and L is the effective length of the beam inside the direct conversion system. The cross sections for slow-ion production by charge exchange and by ionization by fast ions and fast neutrals are, respectively, σ_{01} , $\sigma_{ion,+}$ and $\sigma_{ion,0}$. The coefficient for secondary electron emission γ may be as large

as 4.⁴ For a 10% loss due to gas, $P_{loss} = 0.1 I^+ V^+$. [Equation (1) is slightly pessimistic with respect to the power load due to charge exchange because no free electrons are involved in charge exchange.]

For an equilibrium beam emerging from the neutralizer, $I^0 \sigma_{01} = I^+ \sigma_{10}$, where σ_{01} is the cross section for re-ionization of fast neutrals. Therefore, I^+ and I^0 can be eliminated from the equation. The gas pressure can be computed by requiring that $P_{loss} \ll I^+ V^+$. The result is:

$$n_{gas} L \left(\sigma_{10} + \sigma_{ion,+} + \frac{\sigma_{10}}{\sigma_{01}} \sigma_{ion,0} \right) \ll \frac{V^+}{(V^+ + V^-)(1 + \gamma)} \quad (2)$$

The relevant cross sections⁵ for 120-keV H^+ ions are:

$$\begin{aligned} \sigma_{10} &= 0.14 \times 10^{-16} \text{ cm}^2 \\ \sigma_{01} &= 1.0 \times 10^{-16} \text{ cm}^2 \\ \sigma_{ion,+} &= 2.0 \times 10^{-16} \text{ cm}^2 \\ \sigma_{ion,0} &= 1.1 \times 10^{-16} \text{ cm}^2 \end{aligned} \quad (3a)$$

Thus

$$\left(\sigma_{10} + \sigma_{ion,+} + \frac{\sigma_{10}}{\sigma_{01}} \sigma_{ion,0} \right) = 2.29 \times 10^{-16} \text{ cm}^2 \quad (3b)$$

If $V^+ = 120$ kV, $V^- = 25$ kV, and the value of the coefficient γ is between 1 and 4, then the right side of Equation (2) has a minimum value of 0.17. Therefore, $n_{gas} L \ll 7.3 \times 10^{14}$ molecules/cm². If the effective gas length of the direct conversion system is about 100 cm, the gas density is $n_{gas} \ll 7.3 \times 10^{12}$ molecules/cm³, or $p \ll 2 \times 10^{-4}$ torr.

Using the appropriate cross sections, we have experimentally verified this computation using a 12 keV H^+ beam. In the test, we increased the background gas pressure up to 5×10^{-4} torr while measuring the power loading of the negative electrodes. The increase in power load was consistent with Equation (1).

Rather large pumping speeds are required to maintain $P \ll 2 \times 10^{-4}$ torr. For example, the 15 A total beam of the LBL 120-kV ion source deposits a maximum gas load of about 3 torr liters/second in the direct converter and burial chamber. If this must be pumped at a pressure of 2×10^{-5} torr for high efficiency, a pumping speed of 150,000 liters/second is required.

However, high efficiency is not the first requirement for a development program. Our first objective is to recover energy at some lower efficiency and to prove the effects of gas pressure and of other limitations. Therefore, we conducted our first experiments at 120 keV using only the vacuum system of the LBL test stand,⁶ which consists of an evacuated sphere of sufficient volume to ac-

cept a 0.5 second beam pulse with a pressure rise of 3×10^{-5} torr. The effective pumping speed is limited by the conductance of the 24-inch beam line, which is not more than 30,000 liters/second.

The first tests indicated that 1 to 2 A of ion electron pairs were being produced from the background gas and were attracted to the electrodes, where they produced secondary electrons. When the collector voltage was low, only 1 A of beam ions was collected whereas 10 A passed through the converter. Therefore, after a few milliseconds the 1 to 2 A of electrons dominated the collected ion current and prevented the collector from assuming a positive bias.

For the next 120-kV tests, we are installing a small cryopump in the beam line between the direct converter and the burial chamber. This pump, which has a pumping speed of 16,000 liters/second, will reduce the gas load from the burial chamber and improve the pressure in the direct converter by a factor of 3. Ultimately, the larger cryopump shown in Figure 7 will be installed in this position to attain the required speed. Another possibility, illustrated by Figure 8, is to install cryopanel directly within the converter chamber.

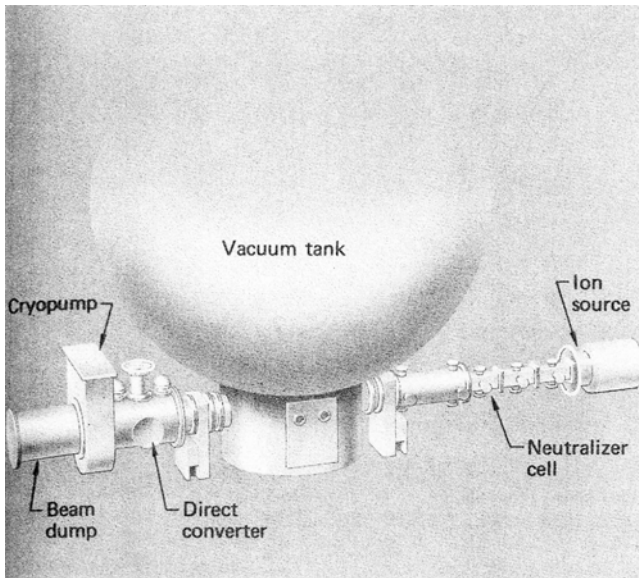

Figure 7 — Lawrence Berkeley Laboratory 120-keV test stand with the direct converter and cryopump

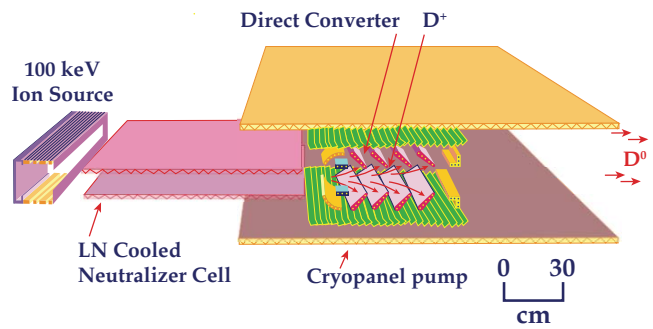

Figure 8 — A proposed 120-keV neutral injector system with a beam direct converter including cryopanel

Density of Gas Streaming from the Neutralizer

In addition to the diffuse background gas that can be reduced to the desired level by pumping, there will be a gas component streaming collisionlessly from the high-density neutralizer. The density of streaming gas is determined by the geometry and cannot be reduced by pumping. The spacing between the neutralizer and the direct converter must be sufficient to attenuate the streaming gas entering the converter and also must be sufficient to accommodate a differential pumping stage at this point.

The number of molecules per second Q flowing from the neutralizer is equal to the number fed into the source minus those converted into ions:

$$Q = \left(\frac{1}{0.3} - 1 \right) \left(\frac{15 \text{ A}}{1.6 \times 10^{-19} \text{ C}} \right) = 1.7 \times 10^{20} \text{ molecules / s} \quad (4)$$

Since the mean free path between molecule-molecule scattering events inside the neutralizer cell is much shorter than the length of the neutralizer, the gas will make good contact with the walls of the cell. It will leave the cell with approximately a cosine distribution and with a thermal velocity distribution corresponding to the temperature of the walls. (In the conceptual design shown in Figure 8, the neutralizer cell is cooled to 77 K to reduce the gas flow when gas is pumped out at both ends of the neutralizer.) In spherical coordinates, the streaming-gas density n at position (r, θ) is obtained from the flux Γ of molecules:

$$\Gamma = n v_{th} = \frac{Q \cos \theta}{\pi r^2} \quad (5)$$

where v_{th} is the thermal speed, equal to 1.3×10^5 cm/s for D_2 at 300 K.

Therefore, the density of streaming gas decreases with the square of the distance from the exit of the neutral-

izer. At 35 cm, the density is below $3.5 \times 10^{16} \text{ cm}^{-3}$; this corresponds to a pressure of 1×10^{-5} torr and can be tolerated by the direct converter. This simple analysis ignores the diameter of the cell. It seems clear, however, that the required separation between the direct converter and the neutralizer cell is not excessive.

Electrode Fabrication

Electrodes for the beam direct converter were designed for a beam with an elliptical cross section that was predicted by trajectory computations.⁷ Beam divergence in the vertical direction was predicted to be four times larger than the divergence in the horizontal direction because the ion source grids were installed horizontally with curvature in one dimension. This asymmetry is favorable for electrostatic electron suppression since the required suppression voltage is roughly proportional to the square of the beam thickness.

The acceptable beam was defined by an elliptical aperture at the entrance of the direct converter, as shown by Figure 9. The vertical and horizontal diameters of this aperture, located 7 m from the ion source (see Figure 7), were 36 cm and 9 cm, defining acceptance angles of $\pm 1.5^\circ$ and $\pm 0.37^\circ$, respectively. During the first series of tests, up to 85% of the beam passed through this aperture and entered the direct converter.

Mechanically, the direct converter consists of three electrodes suspended from high-voltage insulators in a mild-steel vacuum vessel (see Figures 10 and 11). A grounded plate with an elliptical aperture is mounted in the inlet and a back-streaming baffle in the exit of the vessel. The aperture plate is made of water-cooled copper with bolted-on tungsten plates defining the elliptical opening. The alignment of the aperture is adjustable.

There are two negative electrodes and one positive electrode. Each is elliptical and made of nickel-plated copper to reduce sputtering. This combination is acceptable for this experiment; however, future work at higher power loadings will require at least refractory metal coatings and perhaps refractory metal fabrications. These more advanced fabrications have been reviewed and appear feasible; however, the refractory metal fabrications would be quite expensive.

The negative electrodes were hand-formed over aluminum forms that were made by a numerically controlled milling machine. Grooves for cooling tubes were machined in before forming.

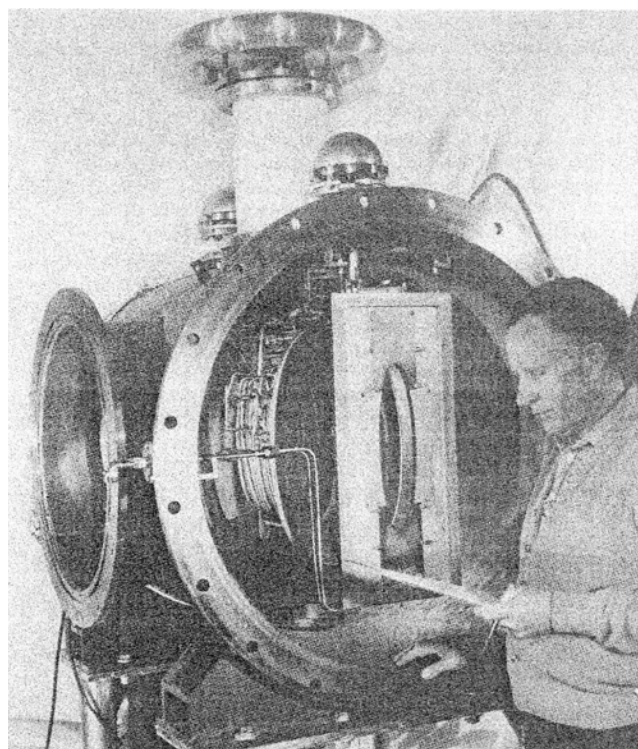

Figure 9 — The Lawrence Livermore Laboratory 120-keV beam direct converter showing the entrance aperture and the collector electrode. The high-voltage shield has been removed to show the water cooling systems.

The straight section of the positive electrode was made in sections in the same manner as the negative electrodes. The front section, a cone with an elliptical cross section, was made from a solid plate by a numerically controlled milling machine. The assembly was completed by adding cooling tubes and bolting the straight and conical sections together.

The three electrodes are adjustable with six degrees of freedom for alignment purposes. Where necessary, shielding helps prevent electrical breakdown.

Direct Converter Diagnostics and Electronics

Recovered beam power is measured by the voltage and current, which are measured electrically at the water-cooled load resistor and also calorimetrically by the temperature rise of the flowing water. The power deposited on each electrode is also measured both calorimetrically and electrically in order to separate the effects of ion and electron bombardment. A fifth calorimetric channel measures the power deposited on the first aperture.

Each of the five channels of calorimetry consists of a water cooling system with a flow-meter and a thermopile to measure the temperature rise of the flowing water. The water systems and the copper electrodes are de-

signed to remove the heat and to measure the energy deposited during the 0.5 second beam pulse on a timescale of 10 seconds following the pulse. This is consistent with beam operation at intervals of 60 seconds. The instrumentation, installed at ground potential, is isolated from the high-voltage electrodes by plastic hoses and low-conductivity water, a system that provides a very inexpensive means of transmitting information from high potential.

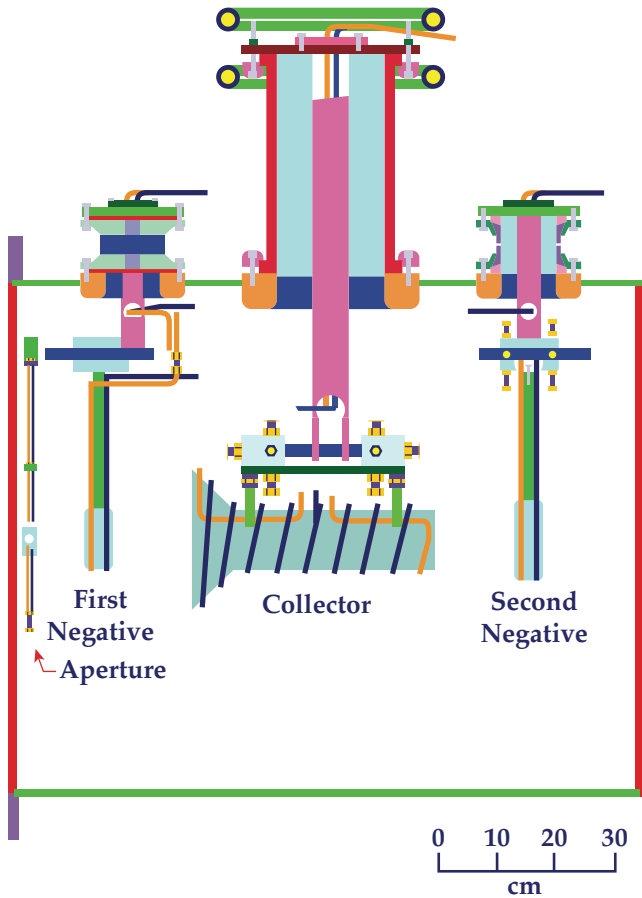

Figure 10 — The electrode assembly, showing electrodes, insulators, and electrode mountings. This view indicates the long dimension of the elliptical cross section in the horizontal direction. Other views would show a 90° rotation of the elliptical cross section.

The two negative electrodes are fed by a single, non-regulated power supply capable of several amperes at 30 kV. The current drawn by each of the negative electrodes is measured by a current transformer suitable for fast measurements and by an electronic sensor suitable for slow measurements.

The position of the contactor that determines the load resistance is remotely controlled and is indicated mechanically.

Other diagnostics consist of a high-speed ion gage to record the rise and fall of gas pressure and probes to

measure the current densities in the halo surrounding the beam.

We mentioned under the subject of gas pumping that the problem identified during the first series of tests was that the collector electrode collected only 1 A of positive ions but several amperes of electrons. Therefore, the collector was not able to bias itself at positive high voltage by the IR drop of the load resistor. To correct this condition, we must improve the ion collection and also reduce the production of electrons in the background gas.

Trajectory computations indicate that under certain conditions the beam must be decelerated to achieve the space-charge blowup required for efficient collection on the collector. Therefore, an external power supply temporarily connected to the collector to decelerate the beam and improve the ion collection might initiate the positive self-biasing.

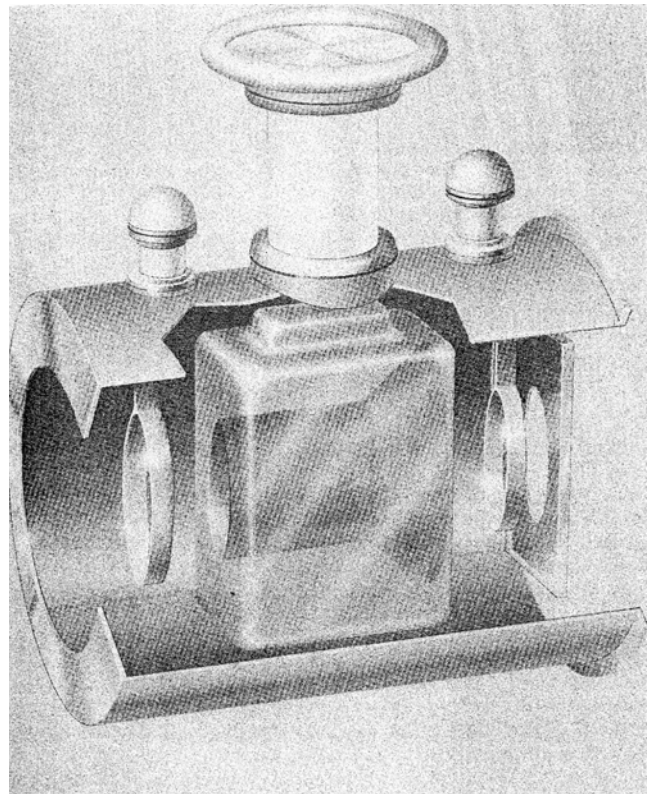

Figure 11 — The beam direct converter electrode assembly

After this condition is achieved, the total collector current will be positive and the startup power supply will not be needed for the remainder of the beam pulse. We have fabricated this circuit and will soon test it operationally. The circuit consists of a capacitor capable of delivering 4 A for 1 ms to apply a voltage of 100 kV temporarily to the collector when the ignitron is fired.

Economics of Beam Direct Conversion

The economic motivations for beam direct conversion in a fusion reactor or large fusion experiment are to reduce the electricity required to accelerate the beams, to reduce the capital cost of power supplies, and to solve the problem of disposing of the high-power charged beam without building bulky bending magnets and large-area beam stops. These economic considerations will become increasingly important as the size and power of controlled fusion experiments increase during the next few years.

Reducing required electricity is of economic importance only if the injection system is operated with a high duty factor, so that the kWh consumption by the injectors is important. However, the availability of many megawatts of pulsed power is a serious problem even for large, pulsed experiments with 1 mv duty factors. Beam direct conversion can reduce the power requirement by 30% to 60% depending upon the beam energy and other conditions.

Reducing the capital cost of power supplies is the most clear-cut economic motivation for beam direct conversion. Large experiments tend to be limited by their capital cost. A substantial fraction of these costs is contributed by the injector power supplies, which cost roughly \$0.2/W. The example illustrated by Figure 2, which is realistic for the injectors of TFTR, shows that the power-supply requirement can be reduced by about 3 MW for each injector. Therefore, if beam direct conversion were used for the 12 injectors of such an experiment, the capital cost saving would be about \$7 million.

Disposal of the high-power charged beam may be possible by direct conversion under conditions not possible by other techniques because our designs indicate that beam power densities of 10 to 20 kW/cm² may be handled by direct conversion (although these power densities exceed the thermal limitations of all known materials for continuous operation). This power density can be handled because the beam not only is decelerated before it is collected but also is spread out over the large-area collector. Consequently, a direct converter may offer the best means of disposing of unused beam.

Conclusions

The principles of beam direct conversion have been successfully tested at medium power levels, and we believe that substantial economics will result from scaling up the system to full power. The new problems involved in the scaling up are associated with electron suppression, gas pumping, voltage holding and initial startup. Because present experiments are directed toward these problems, their solutions will become primarily questions of

engineering rather than of physics. Thus, beam direct converters can be integrated into future neutral-beam sources.

Publishing History

First published on October 25, 1977 in the Proceedings of the 7th Symposium on Engineering Problems of Fusion Research.

Reformatted and color illustrations added in March 2009 by Mark Duncan.

References

¹ Ken W. Ehlers, Klaus H. Berkner, William S. Cooper, J. M. Haughian, Wulf B. Kunkel, B. A. Prichard, Jr., Robert V. Pyle, and J. W. Stearns; "120-keV Neutral Beam Injection System Development," in Proceedings Ninth Symposium on Fusion Technology, Garmisch, Germany, 1976; also Lawrence Berkeley Laboratory, Report LBL-4471 (1976).

² William L. Barr and Ralph W. Moir; "A Review of Direct Energy Conversion for Fusion Reactors," in Proceedings Second Topical Meeting Technology of Controlled Thermonuclear Fusion, Richland, Washington (ANS, 1976), p. 1181; also Lawrence Livermore Laboratory, Report UCRL-78204.

³ John E. Osher and Gordon W. Hamilton; "An Intense Steady-State 20 kV Multiple-Aperture Ion Source MATS III," in Proceedings Second Symposium on Ion Sources and Formation of Ion Beams, Berkeley, CA., 1974 (APS, 1974), p. VI-7-1.

⁴ Lawrence S. Hall, Figure 4 in "Electron Dynamics and the Enhancement of Q in Mirror Magnetic Wells," Nuclear Fusion 17, 681 (1977).

⁵ C. F. Barnett, J. A. Ray, E. Ricci, M. I. Wilker, E. W. McDaniel, E. W. Thomas, and H. B. Gilbody; Physics Division: Atomic Data for Controlled Fusion Research, Oak Ridge National Laboratory, Report ORNL-5206 (1977).

⁶ J. M. Haughian, W. R. Baker, L. A. Biagi, and D. B. Hopkins; "Test Facility for the Development of 150-keV Multi-Megawatt Neutral Beam System," in Proceedings Sixth Symposium Engineering Problems of Fusion Research, San Diego, CA, 1975 (IEEE, 1976), p. 53.

⁷ William S. Copper, Klaus Halbach, and S. B. Magyary; "Computer-Aided Extractor Design," in Proceedings Second Symposium on Ion Sources and Formation of Ion Beams, Berkeley, CA, 1974 (APS, 1974), p. 11-1-1.