

Technician License Syllabus

Author - Jack Tiley AD7FO

© Jack Tiley - September 2011

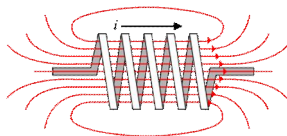
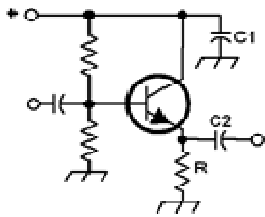

The ARRL
Ham Radio License Manual

All You Need to Become an Amateur Radio Operator!

NEW! Second Edition

- Easy-to-understand "bite-sized" sections. Pass the 35-question Technician Class Exam.
- All the Exam Questions with Answer Key, for use July 1, 2010 to June 30, 2014.
- Designed for self-study and classroom use. Intended for all newcomers, instructors and schoolteachers.
- BONUS Guide for Choosing the Right Radio!

LEVEL 1 Technician LEVEL 2 General LEVEL 3 Amateur Extra

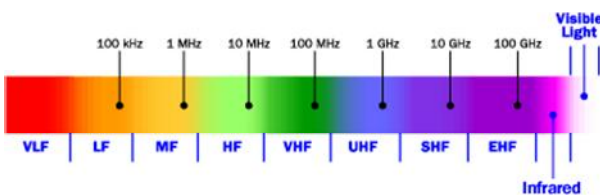
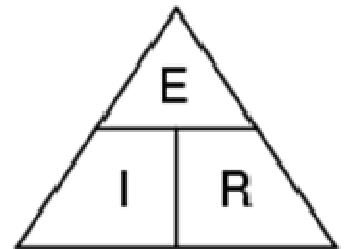

THE AMERICAN RADIO RELAY LEAGUE									
RADIOGRAM									
TO	PRECEDENCE	IS	STANDARD ROUTING	CLASS	CLASS OF SERVICE	THRU	THRU	DATE	TIME
JOHN Q PUBLIC	R	G	R4100	12	CAPT NC			DIC 20	
1234 MAPLE AVE									
AMPTOWN NC 27000									
TELEPHONE NUMBER	919 555 1234								
ARRIVE	7PM	DIC	24	X					
LOOKING	FORWARD	TO	SEEING	YOU					
X	LOVE								
RECD	W2VW	DIC 22	1845	SENT	P21YERD	DIC 22	1905		

Amateur Radio Teaching Syllabus For The Technician (element 2) License Based on the July 2010 Question Pool

Revision 3.10

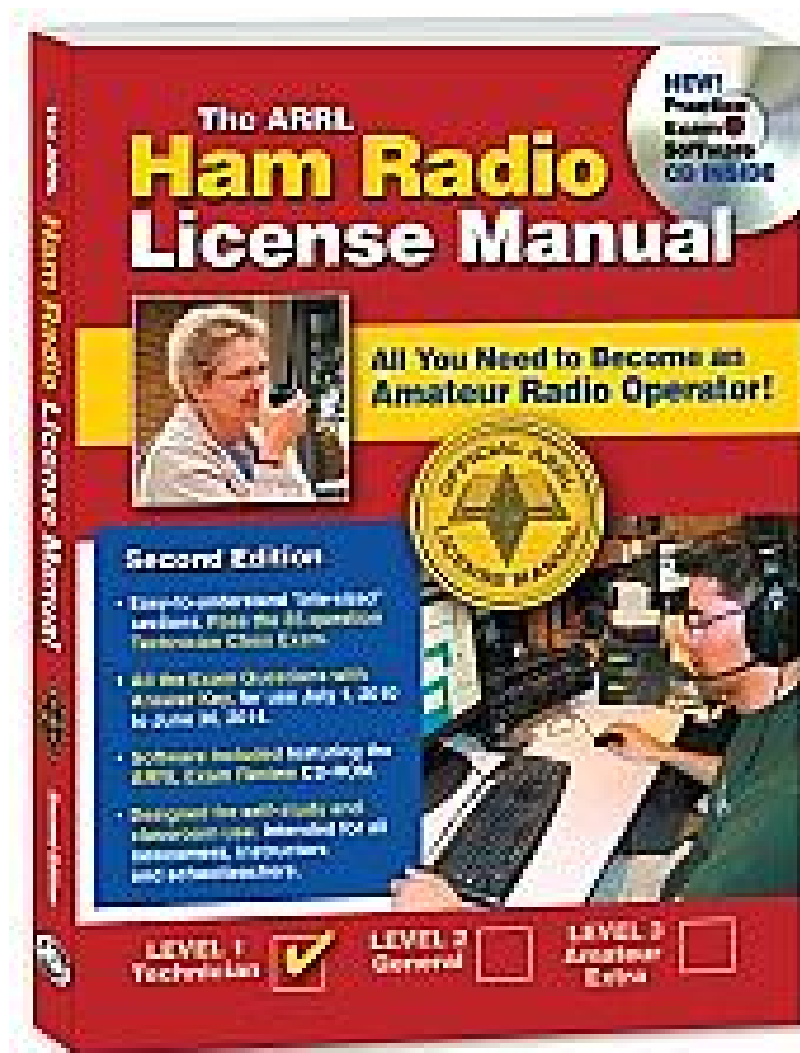

Author : Jack Tiley AD7FO, Spokane Valley WA
Date Published: August 2011, Updated June 2012
e-Mail: ad7fo@arrl.net

About The Author



Education:

Electrical Engineering, Penn State University

Work Experience:

American Electronics Laboratories: Ten years managing a Metrology (Calibration Standards) Laboratory responsible for maintaining test instruments and their calibration traceability to the National Standards Laboratory, **NSIT (previously NBS)**.

Hewlett Packard Test Instrument Group: Thirty four years filling various positions in Technical Support, Application Engineering, Field Sales, World Wide Sales Management, Systems Development and Product Management. Retired in 2004

Hobbies

- É Amateur Radio
- É Test Equipment
- É Electronics in general
- É Attending every hamfest I can, including Hamvention in Dayton Ohio most years

Amateur Radio Activities:

- É Teaching and mentoring
 - Teaching Technician, General and Extra License Classes (with training materials written by author)
 - Write and develop technical presentations for local ham radio clubs (over 20 so far)
 - Lead an amateur radio club at Agilent Technologies (where I used to work). The club operates and maintains a two meter repeater and a 440 repeater with Echo Link. The club web site is <http://www.asarc.org/> where you will find information on activities, repeaters and upcoming hamfests
 - I provide a radio and general purpose test equipment table every year at the Spokane Hamfest for folks to test their radios and other electronic hamfest treasures.
 - I have my own UHF portable repeater (443.400 with 100Hz CTCSS tone).

ARRL Appointments:

- ARRL VE (Volunteer Examiner)
- ARRL Technical Specialist for Spokane area
- ARRL Technical Coordinator for EWA
- ARRL Registered Instructor

Other

- President of the Inland Empire VHF Club
- Member of Spokane ARES/Races . Past Assistant Emergency Coordinator (AEC).

Contact the author via e-mail at ad7f0@arrl.net to be sure you have the latest revision of this syllabus.

Planned Order of instruction is normally two 7-8 hour days, but can be taught as a series of six to eight 2-1/2 hour evening sessions

Day 1

- **Amateur radio overview** - (not in this syllabus)
- **SUBELEMENT T1** . FCC Rules, descriptions and definitions for the amateur radio service, operator and station license responsibilities *(6 exam Questions)*
- **SUBELEMENT T2** - Operating Procedures *(3 exam Questions)*
- **SUBELEMENT T3** . Radio wave characteristics, radio and electromagnetic properties, propagation modes *(3 exam Questions)*
- **SUBELEMENT T4** - Amateur radio practices and station setup *(2 exam Questions)*
- **SUBELEMENT T5** – Electrical principles, math for electronics, electronic principles, Ohm’s Law *(4 exam Questions)*
- **SUBELEMENT T6** – Electrical components, semiconductors, circuit diagrams, component functions *(4 exam Questions)*

Day 2

-
- **SUBELEMENT T7** – Station equipment, common transmitter and receiver problems, antenna measurements and troubleshooting, basic repair and testing *(4 exam Questions)*
- **SUBELEMENT T8** – Modulation modes, amateur satellite operation, operating activities, non-voice communications *(4 exam Questions)*
- **SUBELEMENT T9** – Antennas, feedlines *(2 exam Questions)*
- **SUBELEMENT T10** – AC power circuits, antenna installation, RF hazards *(3 exam Questions)*
- **Stump the instructor** – Student led review ask any ham radio or electronics questions

Suggested preparation:

Please read through the scheduled sections in the syllabus before each class. You are not expected to learn and understand what you read but by being familiar with what will be covered you can identify those areas where you may want focus on and/or bring up questions during the class.

Do not be intimidated. The material will be made easy to understand by your instructor and remember you can skip a whole section, study the others and still pass the exam. The instructor will teach all the sections, but you can choose to focus on the topics you can or want to learn while skipping others and still pass your exam. You can then go back later and learn the areas where you had difficulty. There are many folks, ~~50%~~ ^{60%} in the ham radio community ready to help you. Check in your region for local ARRL technical specialists if you don’t already know a local Ham that can help you.

Technician License Class Syllabus

Compiled By Jack Tiley AD7FO

Based on the ARRL Technician Class License Question pool

Effective 1 July 2010

This material is based on the 2010, Technician Class License (Element 2) question pool with additional information added by the author (*in italicized blue text*).

All questions were re-written with the correct answer only, which in the authors view makes it easier when you see the other choices in your exam to identify the correct answer. Question numbers have been included so you can go to the ARRL Technician Class License Manual, or the question pool itself, to see the actual wording of the questions and other answer choices that will be in the exam.

The **bold text** shown for each question is the exact wording of the answer in the test question.

If there is an FCC (Federal Communications Commission) part 97 rule relating to the answer it is shown following the question number like this: T1A07 **[97.3(a)(45)]**

It is recommended (but not required) that you have your own copy of the current ARRL Technician Class License Manual which is available for purchase from ARRL publication sales on the ARRL web site and through amateur radio dealers. A copy of a recent ARRL Handbook could be used in lieu of purchasing the license manual as a reference to help understand the topics covered in this syllabus.

Many of the illustrations used were copied from the ARRL Handbook CD-ROM and scanned from the license manual with permission from the copyright owner, ARRL, as well as other public sites on the web. This document has been written to assist instructors and students and may be distributed freely as long as no charge for the material is made (except for reproduction costs associated with delivering paper copies or electronic copies on CD-ROM's) and this note of copyright permission is not removed.

The electronic file of this syllabus is usually too large to be e-mailed so an alternate form of distribution (printed, CD-ROM or web posting) will be required.

While every effort was made to insure the accuracy of the material herein, this material was prepared by an ordinary human being, and there is always the possibility that a few typographical or other errors remain. Author welcomes corrections and can be contacted at ad7fo@arrl.net

Additional information and resources to help you study for the Technician Class License can be found on the ARRL web site. This site has articles and resources for reference materials on all aspects of the exam questions.

License Class Requirements

1. It is suggested that you have a copy of the latest ARRL Technician Class (element 2) License Manual or a copy of the ARRL Handbook. **These are recommended but not a must.** You can learn and pass the exam by only studying with this syllabus.

The handbook and license manual are available online directly from ARRL (Amateur Radio Relay League) and many amateur radio dealers and local booksellers. A few web sites are listed below.

<http://www.arrl.org/catalog/index>

<http://www.aesham.com/>

<http://www.hamradio.com/>

2. It is recommended you have a printed copy of this syllabus to study from and to bring to class. We will be working from the syllabus during the class. All the possible questions in the exam are covered in the syllabus.

3. A copy of part 97 of the FCC rules that can be purchased from the ARRL website, ham radio dealers and can be downloaded for free from the following web site <http://www.repeater-builder.com/fcc/2008-part-97-rules.pdf>

3 A Basic Calculator that you are familiar with. A basic scientific calculator is available from office supply stores and Wal-Mart for around \$10.

4. A desire to learn and to ask questions if you do not understand something that is being taught.

5. You must take and pass the Technician Class written exam (element 2)

- There are 35 questions on the exam, All questions are multiple choice
- Questions come from a published pool of questions (all possible questions are covered in this syllabus).
- The number of possible questions for each topic area is fixed and shown for each question group in the syllabus.
- You must have 26 correct answers to pass the test (no more than 9 incorrect answers).
- There are online practice sites with the real test questions you can take for practice. Listed below are three sites where you can take practice exams:

<http://aa9pw.com/radio/>

<http://www.eham.net/exams/>

<http://www.qrz.com/ham/>

US Amateur Radio Bands

US AMATEUR POWER LIMITS

At all times, transmitter power should be kept down to that necessary to carry out the desired communications. Power is rated in watts PEP output. Except where noted, the maximum power output is **1500 Watts**.

Effective Date
February 23, 2007

Published by:
ARRL AMATEUR RADIO
www.arrl.org
225 Main Street, Newington, CT USA 06111-1494

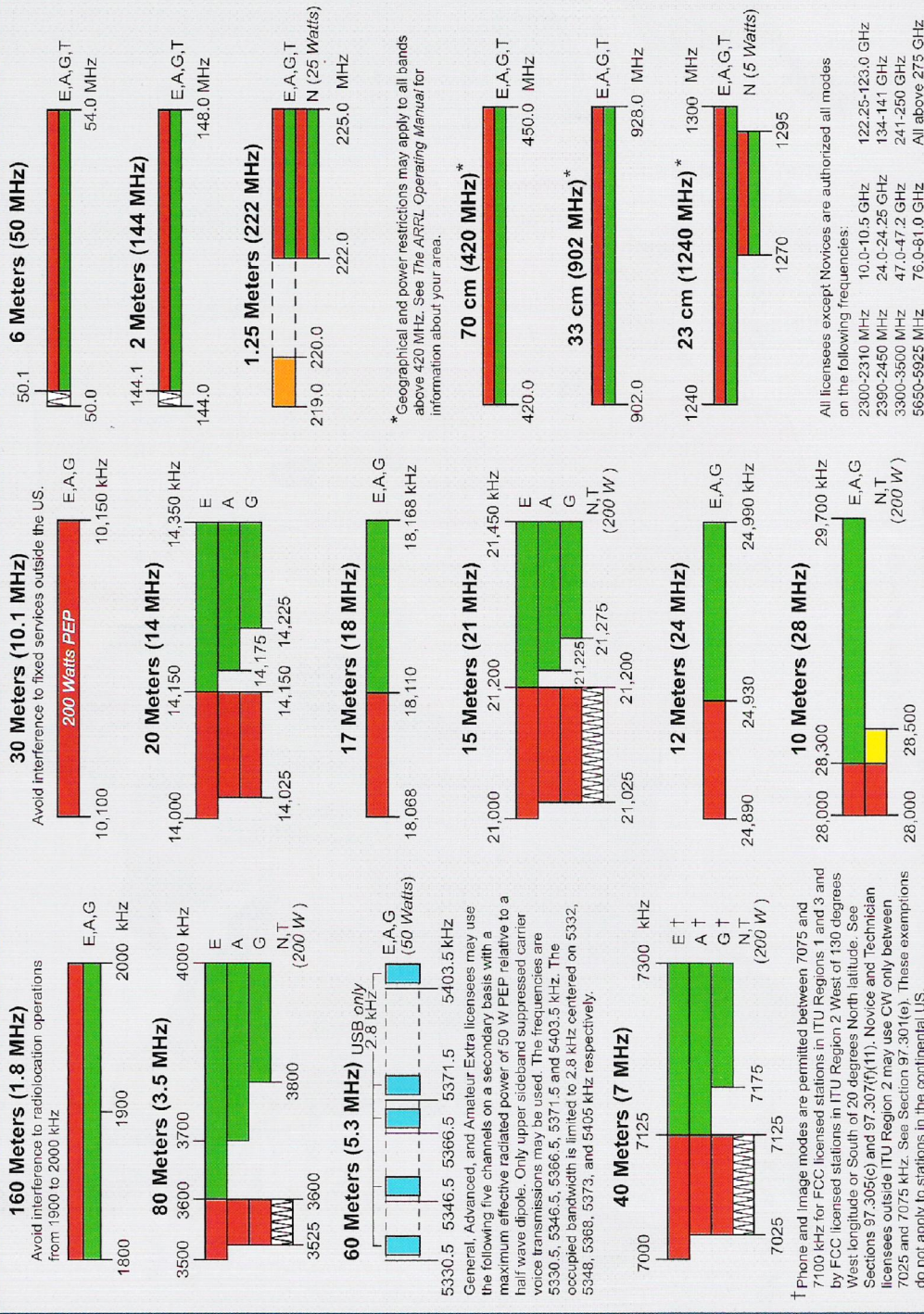

* Geographical and power restrictions may apply to all bands above 420 MHz. See *The ARRL Operating Manual* for information about your area.

† Phone and image modes are permitted between 7075 and 7100 kHz for FCC licensed stations in ITU Regions 1 and 3 and by FCC licensed stations in ITU Region 2 West of 130 degrees West longitude or South of 20 degrees North latitude. See Sections 97.305(c) and 97.307(f)(11). Novice and Technician licensees outside ITU Region 2 may use CW only between 7025 and 7075 kHz. See Section 97.301(e). These exemptions do not apply to stations in the continental US.

KEY

Note: CW operation is permitted throughout all amateur bands except 80 meters. MCW is authorized above 50.1 MHz, except for 219-220 MHz. Test transmissions are authorized above 51 MHz, except for 219-220 MHz.

█ = RTTY and data
█ = phone and image
WWW = CW only
SSB = SSB phone
USB = USB phone only
FD = Fixed digital message forwarding systems only

E = Amateur Extra
A = Advanced
G = General
T = Technician
N = Novice

See *ARRLWeb* at www.arrl.org for more detailed band plans.

ARRL
We're At Your Service

ARRL Headquarters:
860-594-0200 (Fax 860-594-0259)
email: hq@arrl.org

Publication Orders:
www.arrl.org/catalog
Toll-Free 1-888-277-5289 (860-594-0355)
email: orders@arrl.org

Membership/Circulation Desk:
Toll-Free 1-888-277-5289 (860-594-0338)
email: membership@arrl.org

Getting Started in Amateur Radio:
Toll-Free 1-800-328-8942 (860-594-0355)
email: newham@arrl.org

Exams: 860-594-0300 email: vec@arrl.org

Copyright © ARRL 2007 rev 3/26/2007

2010 Technician Class Question Pool consists of 396 questions in 35 sections

SUBELEMENT T1 . FCC Rules, descriptions and definitions for the amateur radio service, operator and station license responsibilities

[6 Exam Questions - 6 Groups]

T1A - Amateur Radio services; purpose of the amateur service, amateur-satellite service, operator/primary station license grant, where FCC rules are codified, basis and purpose of FCC rules, meanings of basic terms used in FCC rules

T1B - Authorized frequencies; frequency allocations, ITU regions, emission type, restricted sub-bands, spectrum sharing, transmissions near band edges

T1C - Operator classes and station call signs; operator classes, sequential, special event, and vanity call sign systems, international communications, reciprocal operation, station license licensee, places where the amateur service is regulated by the FCC, name and address on ULS, license term, renewal, grace period

T1D - Authorized and prohibited transmissions

T1E - Control operator and control types; control operator required, eligibility, designation of control operator, privileges and duties, control point, local, automatic and remote control, location of control operator

T1F - Station identification and operation standards; special operations for repeaters and auxiliary stations, third party communications, club stations, station security, FCC inspection

SUBELEMENT T2 - Operating Procedures

[3 Exam Questions - 3 Groups]

T2A - Station operation; choosing an operating frequency, calling another station, test transmissions, use of minimum power, frequency use, band plans

T2B . VHF/UHF operating practices; SSB phone, FM repeater, simplex, frequency offsets, splits and shifts, CTCSS, DTMF, tone squelch, carrier squelch, phonetics

T2C . Public service; emergency and non-emergency operations, message traffic handling

SUBELEMENT T3 – Radio wave characteristics, radio and electromagnetic properties, propagation modes

[3 Exam Questions - 3 Groups]

T3A - Radio wave characteristics; how a radio signal travels; distinctions of HF, VHF and UHF; fading, multipath; wavelength vs. penetration; antenna orientation

T3B - Radio and electromagnetic wave properties; the electromagnetic spectrum, wavelength vs. frequency, velocity of electromagnetic waves

T3C - Propagation modes; line of sight, sporadic E, meteor, aurora scatter, tropospheric ducting, F layer skip, radio horizon

SUBELEMENT T4 - Amateur radio practices and station setup

[2 Exam Questions - 2 Groups]

T4A . Station setup; microphone, speaker, headphones, filters, power source, connecting a computer, RF grounding

T4B - Operating controls; tuning, use of filters, squelch, AGC, repeater offset, memory channels

SUBELEMENT T5 – Electrical principles, math for electronics, electronic principles, Ohm’s Law

[4 Exam Questions - 4 Groups]

T5A - Electrical principles; current and voltage, conductors and insulators, alternating and direct current

T5B - Math for electronics; decibels, electronic units and the metric system

T5C - Electronic principles; capacitance, inductance, current flow in circuits, alternating current, definition of RF, power calculations

T5D . Ohm’s Law

SUBELEMENT T6 – Electrical components, semiconductors, circuit diagrams, component functions

[4 Exam Groups - 4 Questions]

T6A - Electrical components; fixed and variable resistors, capacitors, and inductors; fuses, switches, batteries

T6B . Semiconductors; basic principles of diodes and transistors

T6C - Circuit diagrams; schematic symbols

T6D - Component functions

SUBELEMENT T7 – Station equipment, common transmitter and receiver problems, antenna measurements and troubleshooting, basic repair and testing

[4 Exam Questions - 4 Groups]

T7A - Station radios; receivers, transmitters, transceivers

T7B . Common transmitter and receiver problems; symptoms of overload and overdrive, distortion, interference, over and under modulation, RF feedback, off frequency signals; fading and noise; problems with digital communications interfaces

T7C . Antenna measurements and troubleshooting; measuring SWR, dummy loads, feedline failure modes

T7D . Basic repair and testing; soldering, use of a voltmeter, ammeter, and ohmmeter

SUBELEMENT T8 – Modulation modes, amateur satellite operation, operating activities, non-voice communications
[4 Exam Questions - 4 Groups]

T8A . Modulation modes; bandwidth of various signals

T8B - Amateur satellite operation; Doppler shift, basic orbits, operating protocols

T8C . Operating activities; radio direction finding, radio control, contests, special event stations, basic linking over Internet

T8D . Non-voice communications; image data, digital modes, CW, packet, PSK31

SUBELEMENT T9 – Antennas, feedlines
[2 Exam Groups - 2 Questions]

T9A . Antennas; vertical and horizontal, concept of gain, common portable and mobile antennas, relationships between antenna length and frequency

T9B - Feedlines; types, losses vs. frequency, SWR concepts, matching, weather protection, connectors

SUBELEMENT T0 – AC power circuits, antenna installation, RF hazards
[3 Exam Questions - 3 Groups]

T0A . AC power circuits; hazardous voltages, fuses and circuit breakers, grounding, lightning protection, battery safety, electrical code compliance

T0B . Antenna installation; tower safety, overhead power lines

T0C - RF hazards; radiation exposure, proximity to antennas, recognized safe power levels, exposure to others

SUBELEMENT T1 –

FCC Rules, descriptions and definitions for the amateur radio service, operator and station license responsibilities - [6 Exam Questions - 6 Groups]

T1A - Amateur Radio services; purpose of the amateur service, amateur-satellite service, operator/primary station license grant, where FCC rules are codified, basis and purpose of FCC rules, meanings of basic terms used in FCC rules

T1A01 [97.3(a)(4)]

The Amateur Radio Service is intended **for Persons who are interested in radio technique solely with a personal aim and without pecuniary (*financial*) interest**

T1A02 [97.1]

The FCC (Federal Communications Commission) is the agency regulates and enforces the rules for the Amateur Radio Service in the United States.

T1A03

Part 97 of the FCC rules contains the rules and regulations governing the Amateur Radio Service.

T1A04 [97.3(a)(23)]

The FCC definition of harmful interference is **that which seriously degrades, obstructs, or repeatedly interrupts a radio communication service operating in accordance with the Radio Regulations.**

T1A05 [97.3(a)(40)]

The FCC Part 97 definition of a space station is **an amateur station located more than 50 km above the Earth's surface.**

T1A06 [97.3(a)(43)]

The FCC Part 97 definition of telecommand is **a one-way transmission to initiate, modify or terminate functions of a device at a distance.**

T1A07 [97.3(a)(45)]

The FCC Part 97 definition of telemetry is **a one-way transmission of measurements at a distance from the measuring instrument.**

Such as transmission of satellite temperature, battery charge state or function reports for radios onboard.

T1A08 [97.3(a)(22)]

The **Frequency Coordinator** recommends transmit/receive channels and other parameters for auxiliary and repeater stations.

An amateur radio auxiliary station is a station controlled and operated from a remote location

T1A09 [97.3(a)(22)]

Amateur operators in a local or regional area whose stations are eligible to be auxiliary or repeater stations select a Frequency Coordinator.

T1A10 [97.3(a)(5)]

The FCC Part 97 definition of an amateur station is **a station in an Amateur Radio Service consisting of the apparatus necessary for carrying on radio communications.**

T1A11 [97.3(a)(7)]

An Auxiliary station **transmits signals over the air from a remote receive site to a repeater for retransmission.**

T1B - Authorized frequencies; frequency allocations, ITU regions, emission type, restricted sub-bands, spectrum sharing, transmissions near band edges

T1B01 [97.3(a)(28)]

The ITU is a **United Nations agency for information and communication technology issues.**

The International Telecommunication Union (Union internationale des télécommunications, in French) is the specialized agency of the United Nations which is responsible for information and communication technologies.

T1B02

North American amateur stations are located in the **Region 2** ITU region.



T1B03 [97.301(a)]

A frequency of **52.525 MHz** is within the 6 meter band.

The 6 meter band is from 50.000 to 54.000 MHz.

T1B04 [97.301(a)]

You are you using the **2 meter band** when your station is transmitting on 146.52 MHz.

The 2 meter band is from 144.000 to 148.000 MHz.

T1B05 [97.301(a)]

A Technician Class license holder operating in ITU Region 2 is authorized to use **443.350 Mhz.**

*The 70 centimeter band for ITU region 2 is from 420.000 to 450.000 MHz.**

** There are some restrictions near the Canadian border where there is Over-lap with Canadian military frequencies.*

T1B06 [97.301(a)]

On the 23 cm band **1296 MHZ** frequency is authorized to a Technician Class operator license.

The 23 centimeter band is from 1,240.000 to 1,300.000 MHz.

T1B07 [97.301(a)]

You are operating in the **1.25 meter** band if you are transmitting on 223.50 MHz.

The 1.25 meter band is from 222.000 to 225.000 MHz.

T1B08 [97.303]

The FCC rules state that when an amateur frequency band is said to be available on a secondary basis **Amateurs may not cause harmful interference to primary users.**

T1B09 [97.101(a)]

You should not set your transmit frequency to be exactly at the edge of an amateur band or sub-band:

- 1. To allow for calibration error in the transmitter frequency display**
- 2. So that modulation sidebands do not extend beyond the band edge**
- 3. To allow for transmitter frequency drift**

T1B10 [97.305(c)]

The 6 meter, 2 meter and 1.25 meter bands which are available to Technician Class operators have mode-restricted sub-bands.

Maximum power on the 1.25 band is 25 watts.

Only CW is permitted from 50.000 to 50.100 and 144.000 to 144.100 MHz.

T1B11 [97.305 (a)(c)]

Only CW (Morse code) emission modes are permitted in the mode-restricted sub-bands at 50.0 to 50.1 MHz and 144.0 to 144.1 MHz.

T1C - Operator classes and station call signs; operator classes, sequential, special event, and vanity call sign systems, international communications, reciprocal operation, station license and licensee, places where the amateur service is regulated by the FCC, name and address on ULS, license term, renewal, grace period T1C01 [97.3(a)(11)(iii)]
Special event call signs have a single letter in both the prefix and suffix.

Examples: W1W , A7R, J4K
Special event stations help commemorate an historical occasion or other special event.
Many special event stations provide a special QSL card or certificate.

T1C02

W3ABC is a valid US amateur radio station call sign.

T1C03 [97.117]

For international contacts **only communications incidental to the purposes of the amateur service and remarks of a personal character** are permitted by an FCC-licensed amateur station.

T1C04

You are allowed to operate your amateur station in a foreign country only when **the foreign country authorizes it.**

T1C05 [97.303(h)]

If you are operating on the 23 cm band and learn that you are interfering with a radiolocation station outside the United States you must **stop operating or take steps to eliminate the harmful interference.**

T1C06 97.5(a)(2)]

An FCC-licensed amateur station may **transmit from any vessel or craft located in international waters and documented or registered in the United States**, in addition to places where the FCC regulates communications.

You may also need permission of the captain of the vessel

T1C07 [97.23]

When correspondence from the FCC is returned as undeliverable because the grantee failed to provide the correct mailing address **revocation of the station license or suspension of the operator license** may occur.

T1C08 [97.25]

Ten years is the normal term for an FCC-issued primary station/operator license grant.

T1C09 (A) [97.21(a)(b)]

The grace period following the expiration of an amateur license within which the license may be renewed is **two years.**

After the 2 year grace period you must take and pass the license exam(s) again.

T1C10 [97.5a]

You can operate a transmitter on an amateur service frequency after you pass the examination required for your first amateur radio license and as soon **as your name and call sign appear in the FCC's ULS database.**

T1C11 [97.21(b)]

If your license has expired and is still within the allowable grace **period transmitting is not allowed until the ULS database shows that the license has been renewed.**

T1D - Authorized and prohibited transmissions

T1D01 [97.111(a)(1)]

Countries where FCC-licensed amateur stations prohibited from exchanging communications are **any country whose administration has notified the ITU that it objects to such communications.**

T1D02 [97.111(a)(5)]

During an Armed Forces Day Communications Test an FCC-licensed amateur station can exchange messages with U.S. military stations.

T1D03 [97.113(a)(4), 97.211(b), 97.217]

Only when transmitting control commands to space stations or radio control craft is the transmission of codes or ciphers allowed to hide the meaning of a message transmitted by an amateur station.

T1D04 [97.113(a)(4), 97.113(e)]

The only time an amateur station is authorized to transmit music is **when it is incidental to an authorized retransmission of manned spacecraft communications.**

Such as background music heard on a space station contact.

T1D05 [97.113(a)(3)]

Amateur radio operators may use their stations to notify other amateurs of the availability of equipment for sale or trade **only when the equipment is normally used in an amateur station and such activity is not conducted on a regular basis.**

T1D06 [97.113(a)(4)]

Transmissions that contain obscene or indecent words or language are prohibited.

T1D07 [97.113(f)]

An amateur station is authorized to automatically retransmit the radio signals of other amateur stations **when the signals are from an auxiliary, repeater, or space station.**

T1D08 [97.113]

The control operator of an amateur station may receive compensation for operating the station only **when the communication is incidental to classroom instruction at an educational institution.**

An example would be a school teacher demonstrating amateur radio to their class

T1D09 [97.113(b)]

Amateur stations are only authorized to transmit signals related to broadcasting, program production, or news gathering, **when no other means is available and only where such communications directly relate to the immediate safety of human life or protection of property.**

T1D10 [97.3(a)(10)]

The term broadcasting in the FCC rules for the amateur services means **transmissions intended for reception by the general public.**

T1D11 [97.113(a)(5)]

Brief transmissions to make station adjustments are permitted in the Amateur Radio Service.

You must identify with your call sign when making tests

T1E - Control operator and control types; control operator required, eligibility, designation of control operator, privileges and duties, control point, local, automatic and remote control, location of control operator

T1E01 [97.7(a)]

An amateur station must have a control operator **only when the station is transmitting.**

T1E02 [97.7(a)]

Only a person for whom an amateur operator/primary station license grant appears in the FCC database or who is authorized for alien reciprocal operation is eligible to be the control operator of an amateur station.

T1E03 [97.103(b)]

The station licensee must designate the station control operator.

If not designated it is assumed the licensee is the control operator

T1E04 [97.103(b)]

The class of operator license held by the control operator determines the transmitting privileges of an amateur station.

You can operate a station on frequencies you are not licensed for if the control operator has a license for those privileges.

T1E05 [97.3(a)(14)]

An amateur station control point **is the location at which the control operator function is performed.**

T1E06 [97.109(d)]

Under **Automatic control** it is permissible for the control operator to be at a location other than the control point.

T1E07 [97.103(a)]

When the control operator is not the station licensee **the control operator and the station licensee are equally responsible** for the proper operation of the station.

T1E08 [97.3(a)]

Automatic control is being used for a repeater when the control operator is not present at a control point.

T1E09 [97.109(a)]

Local control is being used when transmitting using a handheld radio.

T1E10 [97.3]

Remote control is used when the control operator is not at the station location but can indirectly manipulate the operating adjustments of a station.

T1E11 [97.103(a)]

The FCC presumes the **station licensee** to be the control operator of an amateur station, unless documentation to the contrary is in the station records.

T1F - Station identification and operation standards; special operations for repeaters and auxiliary stations, third party communications, club stations, station security, FCC inspection

T1F01

When identifying a station on the air as ~~Base~~ **Race Headquarters**+a **Tactical call** is being used.

Even if using a tactical call you must identify with your call sign at least once every 10 minutes and at the end of your contact.

T1F02 [97.119 (a)]

When using tactical identifiers, you must identify your station by transmitting the station's FCC-assigned call sign **every ten minutes**.

T1F03 [97.119(a)]

An amateur station is required to transmit its assigned call sign **at least every 10 minutes during and at the end of a contact**.

T1F04 [97.119(b)]

The English language is an acceptable language for use for station identification when operating in a phone sub-band.

T1F05 [97.119(b)]

Call sign identification by sending **the call sign using CW or phone emission** is required for a station transmitting phone signals.

T1F06 [97.119(c)]

The following formats of a self-assigned indicator are acceptable when identifying using a phone transmission:

KL7CC stroke W3

KL7CC slant W3

KL7CC slash W3

T1F07 [97.119(c)]

When appending a self-assigned call sign indicator **it must not conflict with any other indicator specified by the FCC rules or with any call sign prefix assigned to another country.**

T1F08 [97.119(e)]

A Technician Class licensee can **never** be the control operator of a station operating in an exclusive Extra Class operator segment of the amateur bands.

T1F09 [97.3(a)(39)]

A **Repeater station** type of amateur station simultaneously retransmits the signal of another amateur station on a different channel (*frequency*) or channels or (*frequencies*).

T1F10 [97.205(g)]

The control operator of the originating station is accountable should a repeater inadvertently retransmit communications that violate the FCC rules.

T1F11 [97.115(a)]

The FCC rules authorize the transmission of non-emergency third party communications to **any station whose government permits such communications.**

T1F12 [97.5(b)(2)]

At least 4 persons are required to be members of a club for a club station license to be issued by the FCC.

T1F13 [97.103(c)]

The station licensee must make the station and its records available for FCC inspection any time upon request by an FCC representative.

**SUBELEMENT T2 –
Operating Procedures [3 Exam Questions - 3 Groups]**

T2A - Station operation; choosing an operating frequency, calling another station, test transmissions, use of minimum power, frequency use, band plans

T2A01

The most common repeater frequency offset in the two meter band is **plus or minus 600 kHz**.

T2A02

The national calling frequency for FM simplex operations in the 70 cm band is **446.000 MHz**

The national calling frequency for the 2 meter band is 146.52 MHz

T2A03

A common repeater frequency offset in the 70 cm band is **plus or minus 5 MHz**.

T2A04

An appropriate way to call another station on a repeater if you know the other station's call sign is to **say the station's call sign then identify with your call sign**.

T2A05

You should transmit **the other station's call sign followed by your call sign** when responding to a call of CQ.

T2A06

An amateur operator when making on-air transmissions to test equipment or antennas must **properly identify the transmitting station**.

T2A07

When making a test transmission **station identification is required at least every ten minutes during the test and at the end**.

T2A08

The meaning of the procedural signal "CQ" is **calling any station**.

See page 70 in the appendix for some of the common procedural and Q signal

T2A09

Saying your call sign is often used in place of "CQ" to indicate that you are listening on a repeater.

T2A10

A band plan, beyond the privileges established by the FCC is a **voluntary guideline for using different modes or activities within an amateur band**.

T2A11 [97.313(a)]

The FCC rule regarding power level used in the amateur bands is that **an amateur must use the minimum transmitter power necessary to carry out the desired communication**.

T2B – VHF/UHF operating practices; SSB phone, FM repeater, simplex, frequency offsets, splits and shifts, CTCSS, DTMF, tone squelch, carrier squelch, phonetics

T2B01

The term used to describe an amateur station that is transmitting and receiving on the same frequency is **Simplex communication**.

T2B02

CTCSS is the term used to describe the use of a sub-audible tone transmitted along with normal voice audio to open the squelch of a receiver.

CTCSS stands for Continuous Tone-Coded Squelch System

T2B03

The muting of receiver audio controlled solely by the presence or absence of an RF signal is called **Carrier squelch**.

T2B04

The following common problems might cause you to be able to hear but not access a repeater even when transmitting with the proper offset:

- **The repeater receiver requires audio tone burst for access**
- **The repeater receiver requires a CTCSS tone for access**
- **The repeater receiver may require a DCS tone sequence for access**

T2B05

The amplitude of the modulating signal determines the amount of deviation of an FM signal.

The louder you speak into your microphone the more deviation your signal will have.

T2B06

When the deviation of an FM transmitter is increased **its signal occupies more bandwidth**.

T2B07

If you receive a report that your station's transmissions are causing splatter or interference on nearby frequencies you should **check your transmitter for off-frequency operation or spurious emissions**.

T2B08

The proper course of action if your station's transmission unintentionally interferes with another station you should **properly identify your transmission and move to a different frequency**

T2B09 [97.119(b)(2)]

Use of a phonetic alphabet is encouraged by the FCC when identifying your station when using phone.

A - Alfa	N - November
B - Bravo	O - Oscar
C - Charlie	P - Papa
D - Delta	Q - Quebec
E - Echo	R - Romeo
F - Foxtrot	S - Sierra
G - Golf	T - Tango
H - Hotel	U - Uniform
I - India	V - Victor
J - Juliet	W - Whiskey
K - Kilo	X - X-Ray
L - Lima	Y - Yankee
M - Mike	Z - Zulu

T2B10

The "Q" signal **QRM** is used to indicate that you are receiving interference from other stations.

Some common Q signal abbreviations are included in the appendix

T2B11

The "Q" signal **QSY** is used to indicate that you are changing frequency.

T2C – Public service; emergency and non-emergency operations, message traffic handling

T2C01 [97.103(a)]

FCC Rules applies to proper operation of your station when using amateur radio at the request of public service officials.

T2C02 [97.113 and FCC Public Notice DA 09-2259]

The government agency sponsoring the event must submit the request for a temporary waiver of Part 97.113 to allow amateur radio operators to provide communications on behalf of their employers during a government sponsored disaster drill.

T2C03 [97.113]

Only when the FCC has granted a government-requested waiver is it legal for an amateur licensee to provide communications on behalf of their employer during a government sponsored disaster drill or exercise.

T2C04

What RACES and ARES have in common is that **both organizations may provide communications during emergencies.**



T2C05 [97.3(a)(37), 97.407]

The Radio Amateur Civil Emergency Service is **a radio service using amateur stations for emergency management or civil defense communications.**

T2C06

A common practice during net operations to get the immediate attention of the net control station when reporting an emergency is to **begin your transmission with “Priority” or “Emergency” followed by your call sign.**

T2C07

To minimize disruptions to an emergency traffic net once you have checked in **do not transmit on the net frequency until asked to do so by the net control station.**

SUBELEMENT T3 –

Radio wave characteristics, radio and electromagnetic properties, propagation modes – [3 Exam Questions - 3 Groups]

T3A - Radio wave characteristics; how a radio signal travels; distinctions of HF, VHF and UHF; fading, multipath; wavelength vs. penetration; antenna orientation

T3A01

If another operator reports that your station's 2 meter signals were strong just a moment ago, but now they are weak or distorted you should **try moving a few feet, as random reflections may be causing multi-path distortion.**

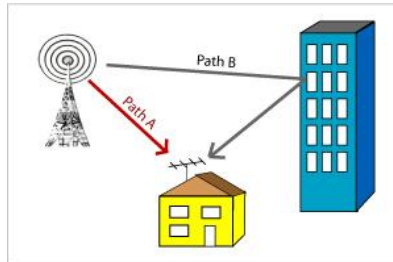

T3A02

UHF signals are often more effective from inside buildings than VHF signals because **the shorter wavelength allows them to more easily penetrate the structure of buildings.**

T3A03

Horizontal antenna polarization is normally used for long-distance weak-signal CW (*Morse Code*) and SSB (*Single Side Band*) contacts using the VHF and UHF bands.

T3A04

If the antennas at opposite ends of a VHF or UHF line of sight radio link are not using the same polarization the **signals could be significantly weaker.**

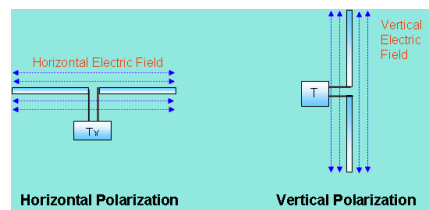
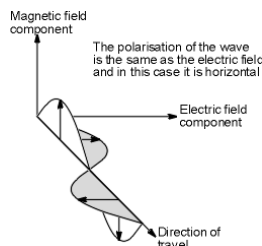

T3A05

When using a directional antenna, your station might be able to access a distant repeater if buildings or obstructions are blocking the direct line of sight path by **trying to find a path that reflects signals to the repeater.**

T3A06

Picket fencing is the term commonly used to describe the rapid fluttering sound sometimes heard from mobile stations that are moving while transmitting.

T3A07

An **electromagnetic** wave carries radio signals between transmitting and receiving stations.

T3A08

Random combining of signals arriving via different path lengths is the cause of irregular fading of signals from distant stations during times of generally good reception.

T3A09

A common effect of "skip" reflections between the Earth and the ionosphere is **the polarization of the original signal is randomized**.

T3A10

If VHF or UHF data signals propagate over multiple paths **error rates are likely to increase**.

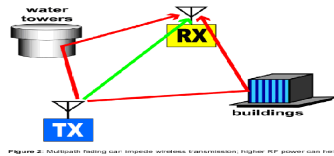

T3A11

The part of the atmosphere enables the propagation of radio signals around the world is **the ionosphere**.

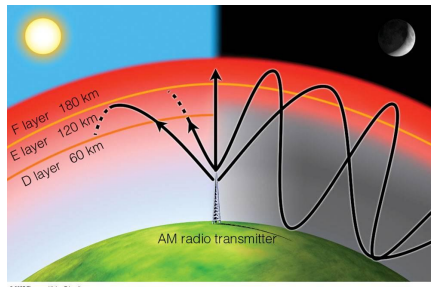

T3B - Radio and electromagnetic wave properties; the electromagnetic spectrum, wavelength vs. frequency, velocity of electromagnetic waves

T3B01

The name for the distance a radio wave travels during one complete cycle is the **wavelength**.

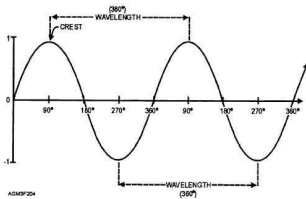

$$\text{Wavelength}(\lambda) = \frac{\text{Velocity}(v)}{\text{Frequency}(f)}$$

↑
~300
↑
In Meters
In MHz

T3B02

Frequency is the term that describes the number of times per second that an alternating current reverses direction.

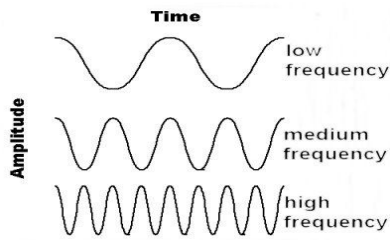

T3B03

Electric and magnetic fields are the two components of a radio wave.

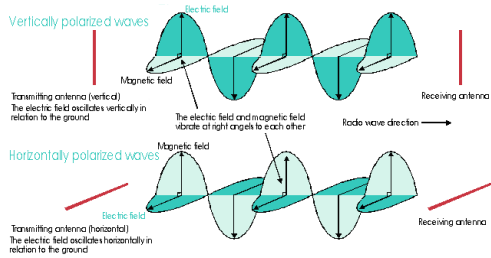

T3B04

A radio wave travels through free space **at the speed of light**.

Approximately 300 (10⁶) meters per second (300,000,000 meters/Second)

T3B05

The wavelength of a radio wave relates to its frequency in that **the wavelength gets shorter as the frequency increases**.

T3B06

The formula for converting frequency to wavelength in meters is the **Wavelength in meters equals 300 divided by frequency in megahertz**

Example: What is the wavelength in meters for 146 MHz?
 = 300/ Frequency(MHZ)
 = 300/146 meters
 = 2.0548 meters

T3B07

The approximate wavelength is the property of radio waves is often used to identify the different frequency bands.

3.5 MHz - 80 Meters	14 MHz - 20 Meters
7.1 MHz - 40 Meters	21 MHz - 15 Meters
28 MHz - 10 Meters	

T3B08

The frequency limits of the VHF spectrum are **30 to 300 MHz**.

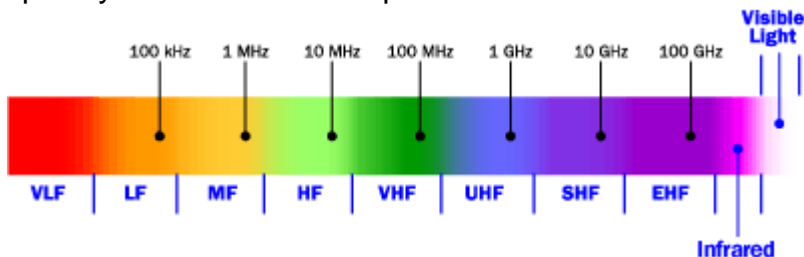

T3B09

The frequency limits of the UHF spectrum are **300 to 3000 MHz**.

T3B10

The frequency range referred to as HF is **3 to 30 MHz**.

T3B11

The approximate velocity of a radio wave as it travels through free space is **300,000,000 meters per second**.

Actual speed of light = 299,792,458 m/s or 983,571,056 ft/s

T3C - Propagation modes; line of sight, sporadic E, meteor, aurora scatter, tropospheric ducting, F layer skip, radio horizon

T3C01

"Direct" (not via a repeater) UHF signals are rarely heard from stations outside your local coverage area because **UHF signals are usually not reflected by the ionosphere**.

T3C02

When VHF signals are being received from long distances it might be because **signals are being refracted from a sporadic E layer**.

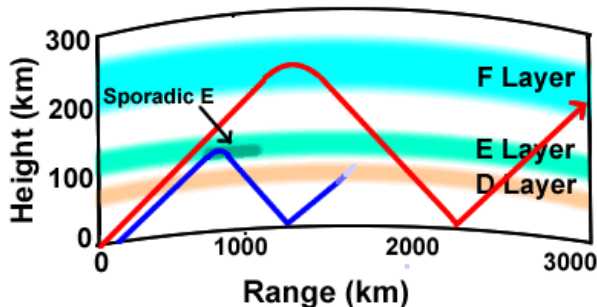

T3C03

A characteristic of VHF signals received via auroral reflection is that **the signals exhibit rapid fluctuations of strength and often sound distorted**.



T3C04

Sporadic E propagation is most commonly associated with occasional strong over-the-horizon signals on the 10, 6, and 2 meter bands.

T3C05

The term "knife-edge" propagation is when **signals are partially refracted around solid objects exhibiting sharp edges**.

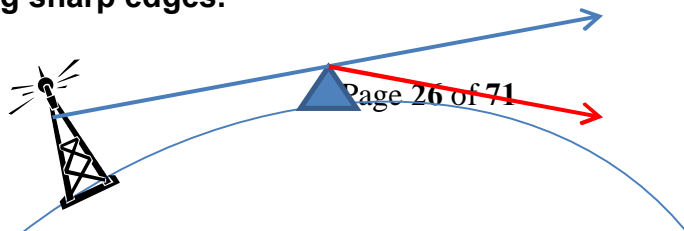

T3C06

Tropospheric scatter is the mode responsible for allowing over-the-horizon VHF and UHF communications to ranges of approximately 300 miles on a regular basis.

The propagation of electromagnetic waves by scattering is a result of irregularities or discontinuities in the physical properties of the troposphere. At the frequencies above 150 MHz, the atmosphere has a scattering effect on electromagnetic fields. The scattering allows over-the-horizon communications at very high, ultrahigh, and microwave frequencies. This mode of communication is called tropospheric scatter, or troposcatter.

T3C07

The **6 meter** band is best suited to communicating via meteor scatter.

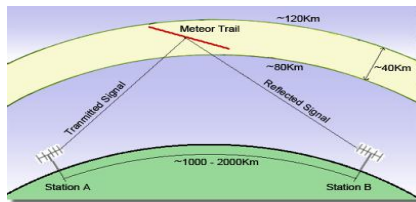

T3C08

Temperature inversions in the atmosphere cause "tropospheric ducting".

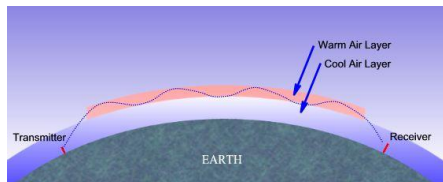

T3C09

Generally the best time for long-distance 10 meter band propagation is **during daylight hours**.

T3C10

The radio horizon is **the distance at which radio signals between two points are effectively blocked by the curvature of the Earth**.

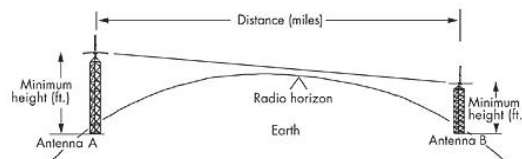

T3C11

VHF and UHF radio signals usually travel somewhat farther than the visual line of sight distance between two stations because **The Earth seems less curved to radio waves than to light**.

As a rule of thumb you can usually communicate at a distance 15% more than the line of sight distance

SUBELEMENT T4 - Amateur radio practices and station set up –
[2 Exam Questions - 2 Groups]

T4A – Station setup; microphone, speaker, headphones, filters, power source, connecting a computer, RF grounding

T4A01

When connecting to the microphone connectors on amateur transceivers **some connectors include push-to-talk and voltages for powering the microphone.**

Just because the connectors are identical does not mean a microphone and radio are compatible.

T4A02

A set of headphones could be used in place of a regular speaker to help you copy signals in a noisy area.

T4A03

A good reason to use a regulated power supply for communications equipment is that **it prevents voltage fluctuations from reaching sensitive circuits.**

T4A04

A filter to reduce harmonic emissions must be connected **between the transmitter and the antenna.**

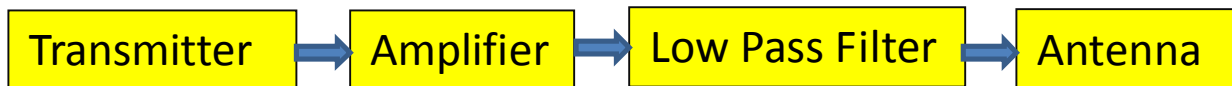

T4A05

A **band-reject filter** should be connected to a TV receiver as the first step in trying to prevent RF overload from a nearby 2 meter transmitter.

T4A06

A **terminal node controller** would be connected between a transceiver and computer in a packet radio station.

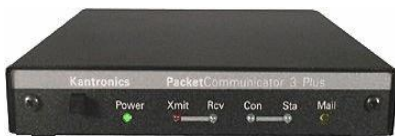

T4A07

When conducting digital communications using a computer **the sound card provides audio to the microphone input and converts received audio to digital form.**

T4A08

Flat strap conductor is best to use for RF grounding.

This minimizes the inductance of the ground connection.

T4A09

To reduce RF current flowing on the shield of an audio cable a **Ferrite choke** could be placed on the cable.



T4A10

The source of a high-pitched whine that varies with engine speed in a mobile transceiver's receive audio is most likely **the alternator**.

T4A11

A mobile transceiver's power negative connection should be made **at the battery (preferred) or engine block ground strap**.

T4B - Operating controls; tuning, use of filters, squelch, AGC, repeater offset, memory channels

T4B01

if a transmitter is operated with the microphone gain set too high **the output signal might become distorted**.

T4B02

The keypad or VFO knob can be used to enter the operating frequency on a modern transceiver.

T4B03

The purpose of the squelch control on a transceiver is **to mute receiver output noise when no signal is being received**.

T4B04

A way to enable quick access to a favorite frequency on your transceiver is to **store the frequency in a memory channel**.

T4B05

Turning on the noise blanker would reduce ignition interference to a receiver.

T4B06

The receiver RIT or clarifier controls could be used if the voice pitch of a single-sideband signal seems too high or low.

T4B07

The term "RIT" means **Receiver Incremental Tuning**.

T4B08

The advantage of having multiple receive bandwidth choices on a multimode transceiver is that it **permits noise or interference reduction by selecting a bandwidth matching the mode**.

T4B09

An appropriate receive filter to select in order to minimize noise and interference for SSB reception would be **2400 Hz**.

The generally accepted bandwidth required for normal voice is approximately 300 Hz to 3 KHz.

T4B10

An appropriate receive filter to select in order to minimize noise and interference for CW reception would be **500 Hz**.

T4B11

The common meaning of the term %repeater offset+is ***the difference between the repeater's transmitted and received frequencies.***

SUBELEMENT T5 –

Electrical principles, math for electronics, electronic principles, Ohm's Law – [4 Exam Questions - 4 Groups]

T5A - Electrical principles; current and voltage, conductors and insulators, alternating and direct current

T5A01

Electrical current is measured in **amperes**.

T5A02

Electrical power is measured in **watts**.

$$\text{Power} = \text{Voltage} \times \text{Current}$$

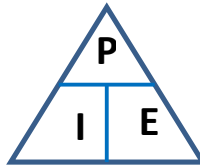

T5A03

The name for the flow of electrons in an electric circuit is **current**.

Current Flow is expressed in Amperes.

T5A04

The name for a current that flows only in one direction is **Direct current**.

T5A05

The electrical term for the electromotive force (EMF) that causes electron flow is **voltage**.

T5A06

A mobile transceiver usually requires **about 12 volts**.

Most radios are actually specified to operate on 13.8 volts which is the battery voltage when a car engine is running and the alternator is charging the battery.

T5A07

Copper is a good electrical conductor.

Aluminum is a poorer conductor than copper and silver and gold are better conductors.

T5A08

Glass is a good electrical insulator.

T5A09

Alternating current is the name for a current that reverses direction on a regular basis.

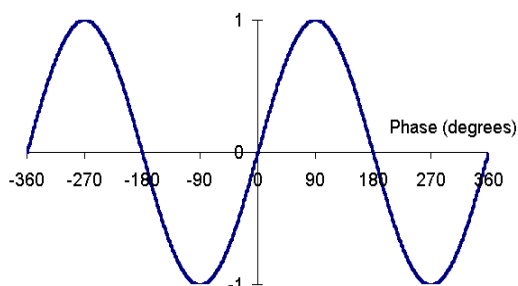

T5A10

Power is the term that describes the rate at which electrical energy is used.

T5A11

The volt is the basic unit of electromotive force.

T5B - Math for electronics; decibels, electrical units and the metric system

T5B01

1,500 milliamperes is equivalent to 1.5 amperes.

$$\text{Milliampere} = 1/1,000 \text{ Amperes} \quad (\text{note 1})$$

T5B02

Another way to specify a radio signal frequency of 1,500,000 hertz is **1,500 kHz**.

T5B03

One thousand volts are equal to one kilovolt.

$$\text{Kilo} = \text{times } 1,000 \quad (\text{note 1})$$

T5B04

One one-millionth of a volt is equal to one microvolt.

$$\text{Microvolt} = 1 / 1,000,000 \text{ or } .000,001$$

T5B05

The equivalent of 500 milliwatts is **0.5 watts**.

$$1,000 \text{ Milliwatts} = 1 \text{ watt} \quad (\text{note 1})$$

T5B06

If an ammeter calibrated in amperes is used to measure a 3,000-milliampere current, it would show a reading of **3 amperes**.

$$1,000 \text{ Milliampere} = 1 \text{ ampere} \quad (\text{note 1})$$

T5B07

If frequency readout calibrated in megahertz shows a reading of 3.525 MHz, it would show a reading of **3,525 kHz** if it were calibrated in kilohertz.

$$1,000 \text{ kilohertz (KHz)} = 1 \text{ megahertz (MHz)} \quad (\text{note 1})$$

T5B08

A value of **1 microfarad** is equivalent to 1,000,000 picofarads.

$$1,000,000 \text{ Picofarads (pf)} = 1 \text{ microfarad } (\mu\text{f}) \quad (\text{note 1})$$

(note 1) - See appendix for international metric system prefixes.

T5B09

The approximate amount of change, measured in decibels (dB), of a power increase from 5 watts to 10 watts is **3 dB**.

dB Calculations

Power $dB = 10 * LOG (P1/P2)$ *P1 and P2 must be the same i.e.: μ Watts. Milliwatts or Watts*

Voltage - $dB = 20 * LOG (V1/V2)$ *V1 and V2 must be the same i.e.: μ volts. Millivolts or Volts*

The following table will allow you to quickly estimate dB gain or loss. The one and two dB values are close enough to get you to the correct answer in the test.

<i>Gain (+)</i>	<i>dB</i>	<i>Loss (-)</i>
<i>x 1.2</i>	<i>1</i>	<i>80%</i>
<i>x 1.6</i>	<i>2</i>	<i>63%</i>
<i>x 2</i>	<i>3</i>	<i>50%</i>
<i>x 4</i>	<i>6</i>	<i>25%</i>
<i>x 10</i>	<i>10</i>	<i>10%</i>

T5B10

The approximate amount of change, measured in decibels (dB), of a power decrease from 12 watts to 3 watts would be minus **6 dB**.

Since 3 dB is 50 %, 6 watts; another 3dB would 50% of that 6 watts or for -6 dB for a 12 watt signal would be 3 watts.

T5B11

The approximate amount of change, measured in decibels (dB), of a power increase from 20 watts to 200 watts would be **10 dB**

See T5B09 above

T5C - Electronic principles; capacitance, inductance, current flow in circuits, alternating current, definition of RF, power calculations

T5C01

The ability to store energy in an electric field is called **Capacitance**.

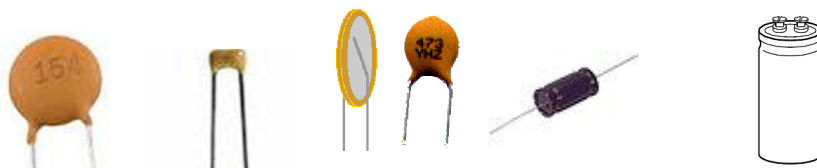

Common Capacitors

T5C02

The **farad** is the basic unit of capacitance.

T5C03

The ability to store energy in a magnetic field is called **Inductance**.

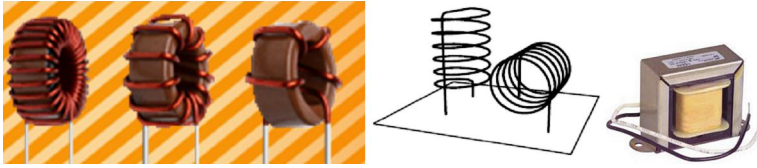

T5C04

The **henry** is the basic unit of inductance.

T5C05

The **Hertz** is the basic unit of frequency.

T5C06

RF is the abbreviation that refers to radio frequency signals of all types and frequencies.

T5C07

Radio wave is a usual name for electromagnetic waves that travel through space.

T5C08

The formula used to calculate electrical power in a DC circuit is **Power (P) equals voltage (E) multiplied by current (I)**

$$\text{Power} = \text{Voltage} \times \text{Current} \text{ or } P = E \times I \text{ (see T5A02 for more information)}$$

T5C09

138 watts of power is being used in a circuit when the applied voltage is 13.8 volts DC and the current is 10 amperes.

$$P = E \times I \text{ or } P = 13.8 \times 10 \text{ or } P = 138 \text{ watts}$$

T5C10

30 watts of power is being used in a circuit when the applied voltage is 12 volts DC and the current is 2.5 amperes.

$$P = E \times I \text{ or } P = 12 \times 2.5 \text{ or } P = 30 \text{ watts}$$

T5C11

10 amperes of current are flowing in a circuit when the applied voltage is 12 volts DC and the load is 120 watts.

$$P = E \times I \text{ or rewriting } I = P / E \text{ or } P = 120 / 12 \text{ or } P = 10 \text{ Amperes}$$

T5D – Ohm's Law

T5D01

The formula is used to calculate current in a circuit is . **Current (I) equals voltage (E) divided by resistance (R).**

$$I_{\text{ (current)}} = \frac{E_{\text{ (voltage)}}}{R_{\text{ (resistance)}}$$

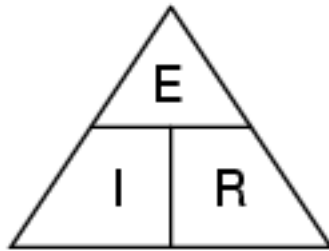

The Ohms law Triangle

To find any value cover it on the triangle and you will see the relationship of the other two variables. For example cover the I and you will see that it is equal to the voltage divided by the resistance.

T5D02

The formula is used to calculate voltage in a circuit is **Voltage (E) equals current (I) multiplied by resistance (R).**

$$E = I \times R$$

T5D03

The formula is used to calculate resistance in a circuit is **Resistance (R) equals voltage (E) divided by current (I).**

$$R = E / I$$

T5D04

The resistance of a circuit in which a current of 3 amperes flows through a resistor connected to 90 volts is **30 ohms.**

$$R = E / I \text{ or } R = 90 / 3 \text{ or } R = 30 \text{ ohms}$$

T5D05

The resistance in a circuit for which the applied voltage is 12 volts and the current flow is 1.5 amperes is **8 ohms.**

$$R = E / I \text{ or } R = 12 / 1.5 \text{ or } R = 8 \text{ ohms}$$

T5D06

The resistance of a circuit that draws 4 amperes from a 12-volt source is **3 ohms.**

$$R = E / I \text{ or } R = 12 / 4 \text{ or } R = 3 \text{ ohms}$$

T5D07

What is the current flow in a circuit with an applied voltage of 120 volts and a resistance of 80 ohms is **1.5 amperes**.

$$I = E / R \text{ or } I = 120 / 80 \text{ or } I = 1.5 \text{ Amperes}$$

T5D08

The current flowing through a 100-ohm resistor connected across 200 volts is 2 amperes.

$$I = E / R \text{ or } I = 200 / 100 \text{ or } I = 2 \text{ Amperes}$$

T5D09

The current flowing through a 24-ohm resistor connected across 240 volts is **10. Amperes**.

$$I = E / R \text{ or } I = 240 / 24 \text{ or } I = 10 \text{ Amperes}$$

T5D10

The voltage across a 2-ohm resistor if a current of 0.5 amperes flows through it is **1 volt**.

$$E = I \times R \text{ or } I = .5 \times 2 \text{ or } E = 1 \text{ Volts}$$

T5D11

The voltage across a 10-ohm resistor if a current of 1 ampere flows through it is **10 volts**.

$$E = I \times R \text{ or } I = 1 \times 10 \text{ or } E = 10 \text{ Volts}$$

T5D12

The voltage across a 10-ohm resistor if a current of 2 amperes flows through it is **20 volts**.

$$E = I \times R \text{ or } I = 2 \times 10 \text{ or } E = 20 \text{ Volts}$$

SUBELEMENT T6 –

**Electrical components, semiconductors, circuit diagrams, component functions –
[4 Exam Questions - 4 Groups]**

**T6A - Electrical components; fixed and variable resistors, capacitors, and inductors;
fuses, switches, batteries**

T6A01

The electrical component is used to oppose the flow of current in a DC circuit is a **Resistor**.



T6A02

The type of component is often used as an adjustable volume control is a **Potentiometer**.

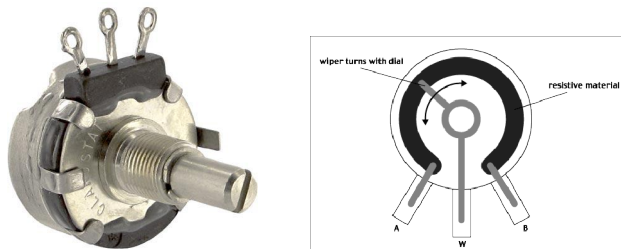

T6A03

Resistance is the electrical parameter is controlled by a potentiometer.

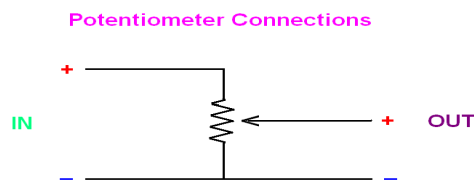

T6A04 (B)

A **Capacitor** is the electrical component that stores energy in an electric field.

T6A05

A **Capacitor** is the electrical component that consists of two or more conductive surfaces separated by an insulator.

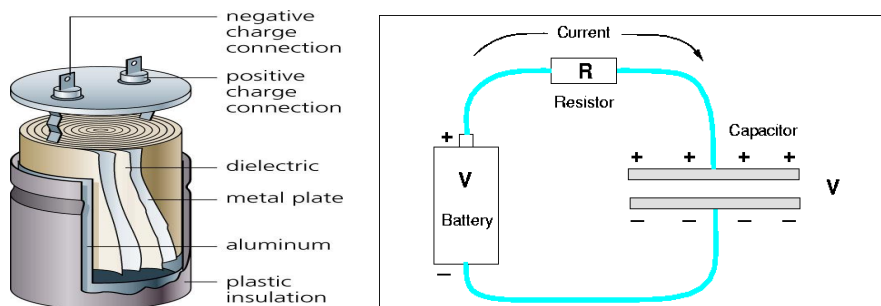

T6A06

An **inductor** stores energy in a magnetic field.

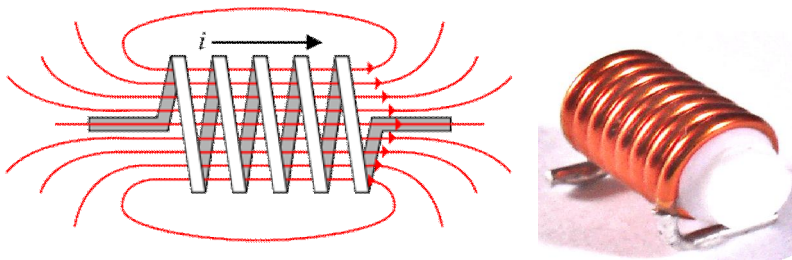

T6A07

An **inductor** is usually composed of a coil of wire.

T6A08

A **switch** is used to connect or disconnect electrical circuits.

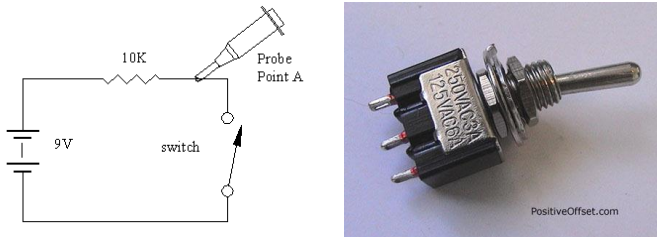

T6A09

A **fuse** is the electrical component is used to protect other circuit components from current overloads.



T6A10

The nominal voltage of a fully charged nickel-cadmium cell is **1.2 volts**.

T6A11

Carbon-zinc batteries are not rechargeable.

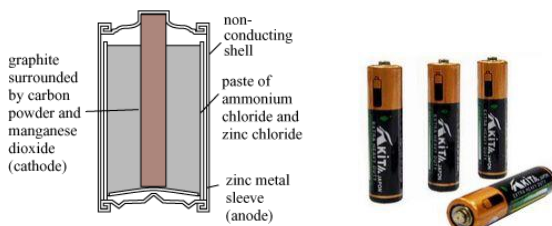

6B – Semiconductors; basic principles of diodes and transistors

T6B01

Transistors are capable of using a voltage or current signal to control current flow.

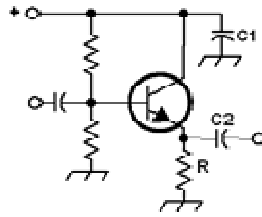
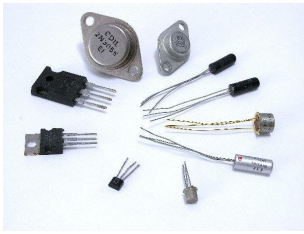

T6B02

A **diode** allows current to flow in only one direction.

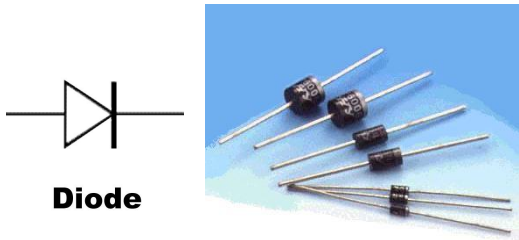

Diode

T6B03

A **Transistor** can be used as an electronic switch or amplifier.

T6B04

A **bipolar junction transistor** is made of three layers of semiconductor material.

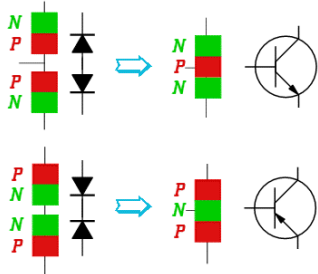

T6B05

A **Transistor** is an electronic component that can amplify signals.

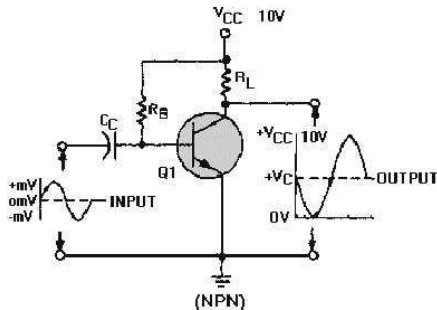

T6B06

A semiconductor diode's cathode lead is usually identified **with a stripe**.

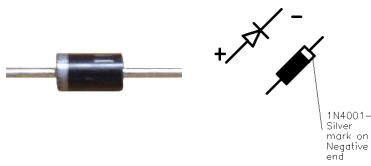

Current flows from the anode to the cathode in a diode assuming a positive voltage is applied to the anode. When a negative voltage is applied to the anode no current will flow to the cathode.

T6B07

The abbreviation "LED" stands for **Light Emitting Diode**.

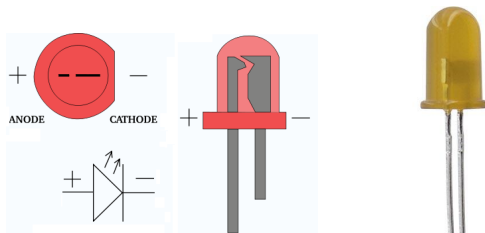

T6B08 (A)

The abbreviation "FET" stands for **Field Effect Transistor**.

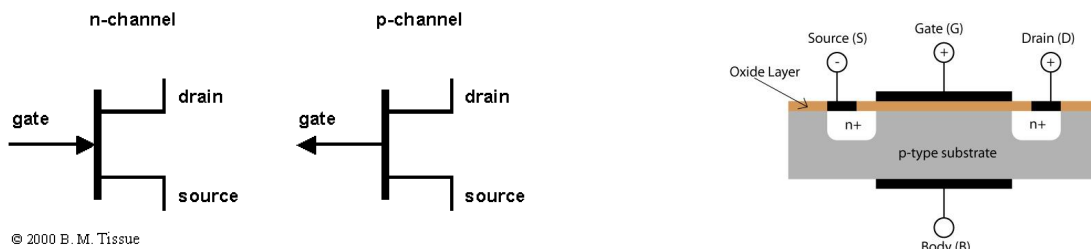

© 2000 B. M. Tissue

The field effect transistor has a very high impedance and does not require any current flow in the gate circuit to control the current flow from the source to the drain. Only a bias voltage is required to control the current flow.

T6B09

The names of the two electrodes of a diode are **Anode and cathode**.

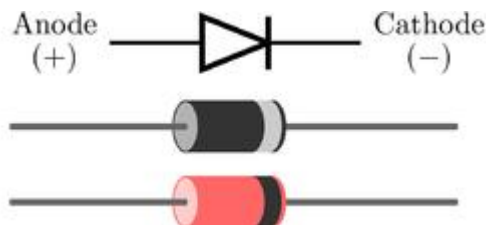

T6B10

A **Bipolar transistor** semiconductor component has an emitter electrode.

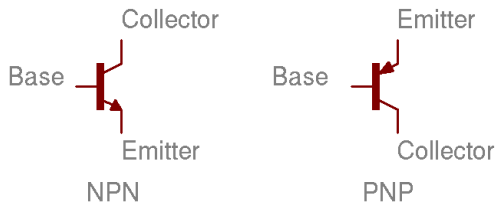

T6B11

A **Field effect transistor** semiconductor component has a gate electrode.

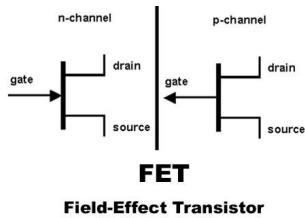

T6B12

Gain is the term that describes a transistor's ability to amplify a signal.

T6C - Circuit diagrams; schematic symbols

T6C01

The name for standardized representations of components in an electrical wiring diagram is **Schematic symbols**.

T6C02

Component 1 in figure T1 is a **resistor**

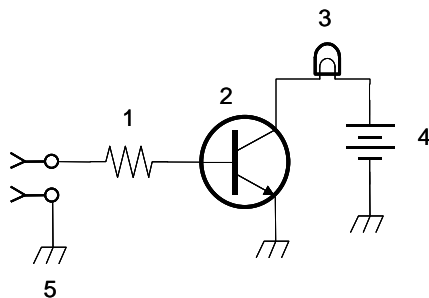

Figure T1

T6C03

Component 2 in figure T1 is a **Transistor**

T6C04

Component 3 in figure T1 is a **lamp**.

T6C05

Component 4 in figure T1 is a **battery**.

T6C06

Component 6 in figure T2 is a **capacitor**.

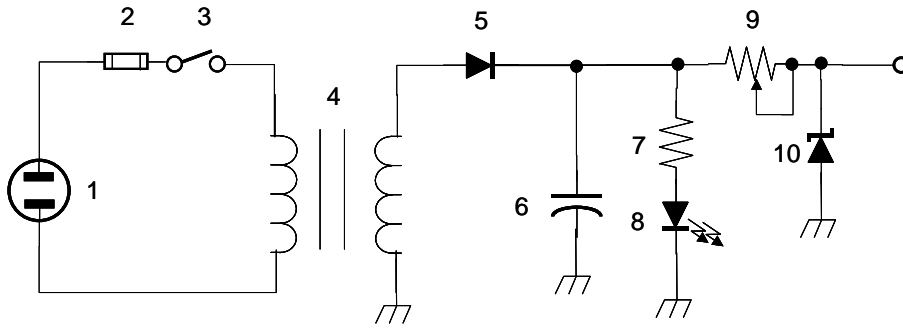

Figure T2

T6C07

Component 8 in figure T2 is a **light emitting diode**.

T6C08

Component 9 in figure T2 is a **Variable resistor** (Also could be identified as a potentiometer).

T6C09

Component 4 in figure T2 is a **transformer**.

T6C10

Component 3 in figure T3 is a **variable inductor**.

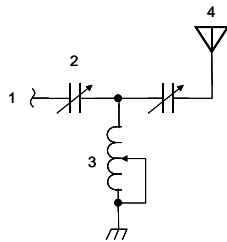

Figure T3

T6C11

Component 4 in figure T3 is an **antenna**.

T6C12

The symbols on an electrical circuit schematic diagram represent **Electrical components**.

T6C13

The way components are interconnected is accurately represented in electrical circuit schematic diagrams.

T6D - Component functions

T6D01

A **rectifier** (diode) changes an alternating current into a varying direct current signal.

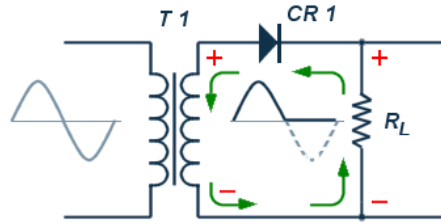

T6D02 (A)

A relay is a **switch controlled by an electromagnet**.

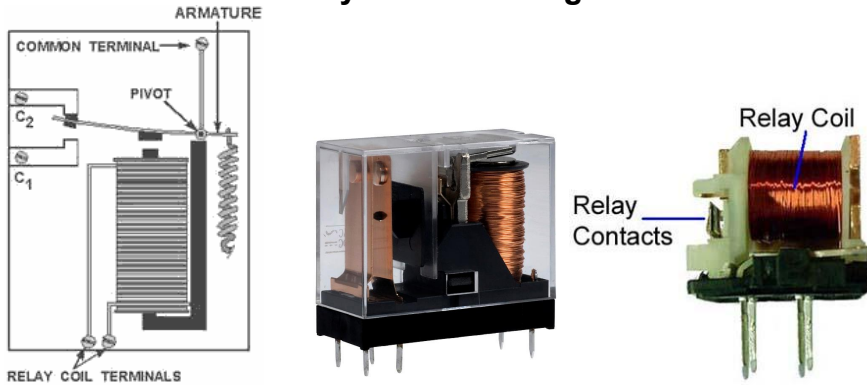

T6D03 (A)

A **Single-pole single-throw** type of switch is represented by item 3 in figure T2.

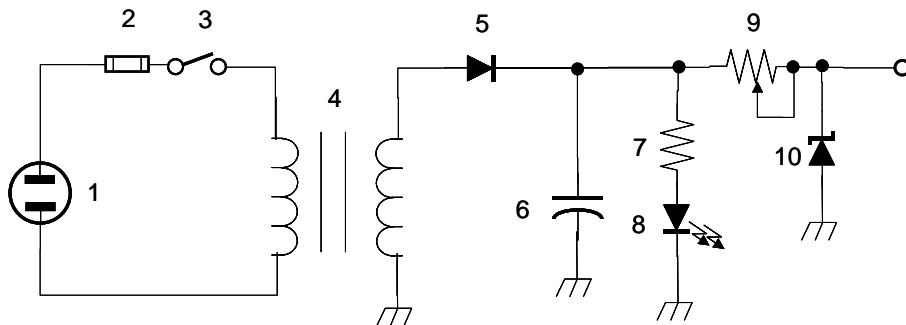
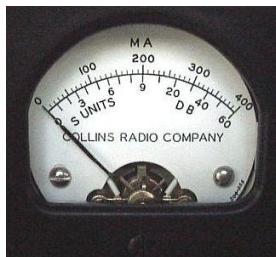

Figure T2

T6D04 (C)

A **Meter** can be used to display signal strength on a numeric scale.



T6D05 (A)

A **Regulator** circuit controls the amount of voltage from a power supply.

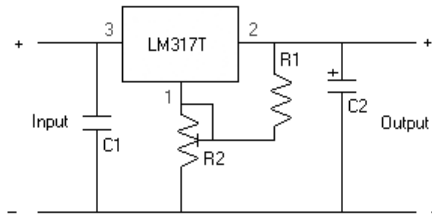

T6D06

A **Transformer** is commonly used to change 120V AC house current to a lower AC voltage for other uses.

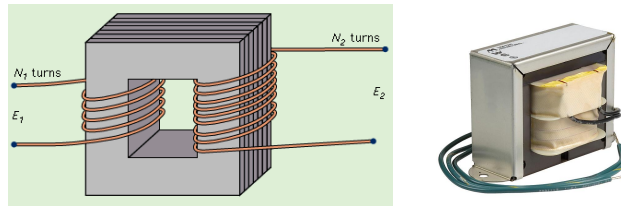

T6D07

An LED (Light Emitting Diode) is commonly used as a visual indicator.

T6D08

A capacitor is used together with an inductor to make a tuned circuit.

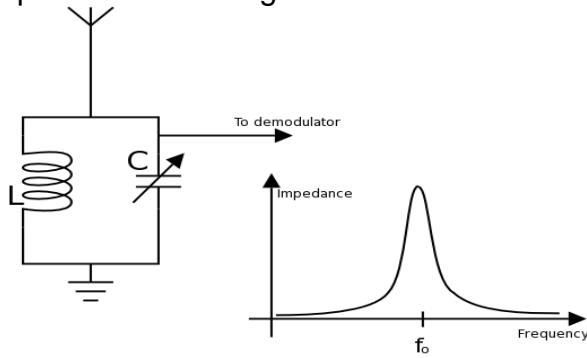

T6D09

An **Integrated circuit** is a device that combines several semiconductors and other components into one package.

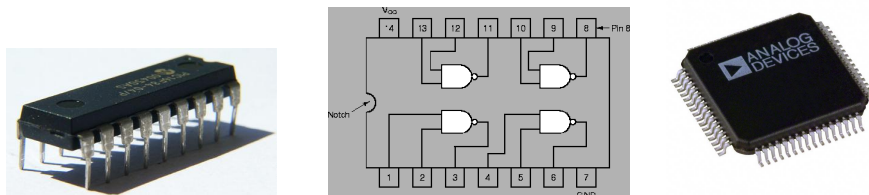

T6D10

The function of component 2 in Figure T1 is to **Control the flow of current.**

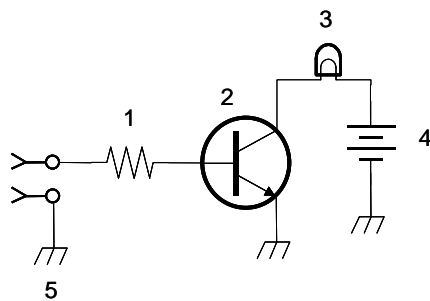
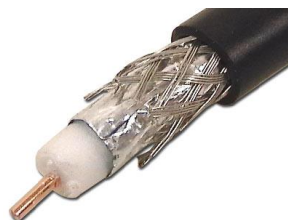
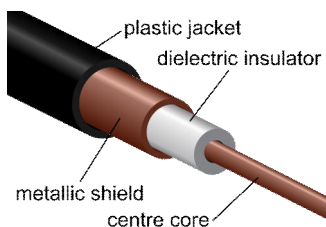

Figure T1

A current applied to the base of the transistor through the resistor (#1) will control the current flowing to the lamp (#3) from the battery (#4). A small current change through R (#1) will create a larger current change through the lamp (#3).

T6D11

A common use of coaxial cable is to **Carry RF signals between a radio and antenna.**



SUBELEMENT T7 –

Station equipment; common transmitter and receiver problems, antenna measurements and troubleshooting, basic repair and.

[4 Exam Questions - 4 Groups]

T7A - Station radios; receivers, transmitters, transceivers

T7A01

The function of a product detector in a receiver is to **Detect CW and SSB signals.**

T7A02

The receiver is shown in Figure T6 is a **Single-conversion superheterodyne receiver.**

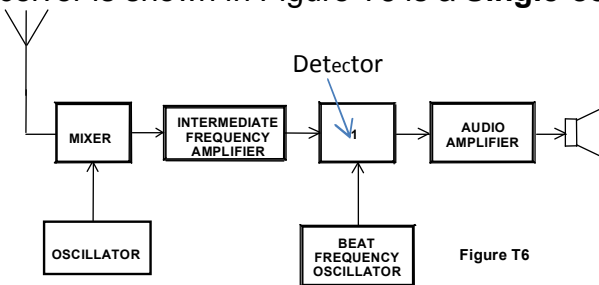

T7A03

The function of a mixer in a superheterodyne receiver is **to shift the incoming signal to an intermediate frequency.**

T7A04

In Figure T7, if block 1 is a frequency discriminator it is **an FM receiver.**

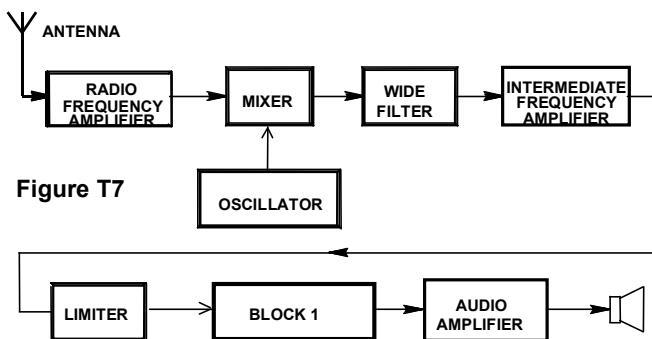

T7A05

The function of block 1 is as **Oscillator** if figure T4 is a simple CW transmitter.

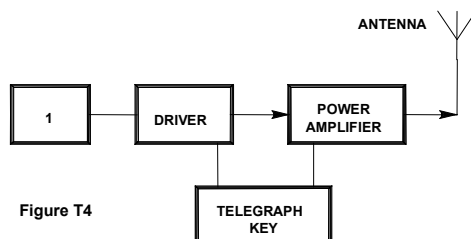

T7A06

A **Transverter** takes the output of a low-powered 28 MHz SSB exciter and produces a 222 MHz output signal.

A Transverter is a transceiver frequency converter

T7A07

If figure T5 represents a transceiver in which block 1 is the transmitter portion and block 3 is the receiver portion, the function of block 2 is a **transmit-receive switch**.

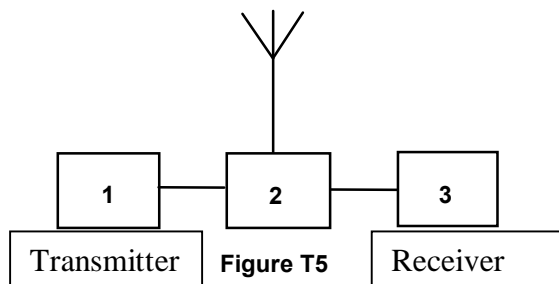

T7A08

A **Modulator** circuit combines a speech signal and an RF carrier.

T7A09 (B)

A **multi-mode VHF transceiver** is most useful for VHF weak-signal communication.

This is because most weak signal communication is conducted with SSB or CW. Standard radios do not have that capability.

T7A10

An **RF power amplifier** can be used to increase the low-power output from a handheld transceiver.



T7A11

A **Discriminator** circuit demodulates FM signals.

T7A12

Selectivity is the term that describes the ability of a receiver to discriminate between multiple signals.

T7A13

An RF preamplifier would be installed **between the antenna and receiver**.

T7B – Common transmitter and receiver problems; symptoms of overload and overdrive, distortion, interference, over and under modulation, RF feedback, off frequency signals; fading and noise; problems with digital communications interfaces

T7B01

If you are told your FM handheld or mobile transceiver is over deviating you should **talk farther away from the microphone.**

This will reduce your FM deviation. Excess deviation will cause distortion in a receiver.

1T7B02

Fundamental overload in reference to a receiver is **interference caused by very strong signals.**

T7B03

The following may be a cause of radio frequency interference:

- A. Fundamental** overload (*A signal strong enough to overload at the tuned frequency*)
- B. Harmonics** (*Signals that are multiples of your transmit frequency*)
- C. Spurious emissions** (*signals at any other frequency caused by the transmitter*)

T7B04

The most likely cause of interference to a non-cordless telephone from a nearby transmitter is **the telephone is inadvertently acting as a radio receiver.**

T7B05

A logical first step when attempting to cure a radio frequency interference problem in a nearby telephone would be to **install an RF filter at the telephone.**

T7B06

If someone tells you that your station's transmissions are interfering with their radio or TV reception the first thing you should do is **make sure that your station is functioning properly and that it does not cause interference to your own television or radio.**

T7B07

The following may be useful in correcting a radio frequency interference problem:

- A. Snap-on ferrite chokes**
- B. Low-pass and high-pass filters**
- C. Band-reject and band-pass filters**

T7B08

If a "Part 15" device in your neighbor's home is causing harmful interference to your amateur station you should:

- A. Work with your neighbor to identify the offending device**
- B. Politely inform your neighbor about the rules that require him to stop using the device if it causes interference**
- C. Check your station and make sure it meets the standards of good amateur practice**

T7B09

If another operator reports a variable high-pitched whine on the audio from your mobile transmitter it might be **noise on the vehicle's electrical system is being transmitted along with your speech audio.**

T7B10

If you receive a report that your audio signal through the repeater is distorted or unintelligible it may be:

- A. Your transmitter may be slightly off frequency**
- B. Your batteries may be running low**
- C. You could be in a bad location**

T7B11

A symptom of RF feedback in a transmitter or transceiver would be **reports of garbled, distorted, or unintelligible transmissions.**

T7B12

The acronym "BER" mean when applied to digital communications systems stands for **Bit Error Rate.**

T7C – Antenna measurements and troubleshooting; measuring SWR, dummy loads, feedline failure modes

T7C01

The primary purpose of a dummy load is **to prevent the radiation of signals when making tests.**

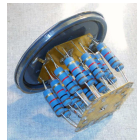

T7C02

An antenna analyzer can be used to determine if an antenna is resonant at the desired operating frequency.



T7C03

In general terms, standing wave ratio (SWR) is **a measure of how well a load is matched to a transmission line.**

T7C04

A reading of **1 to 1** on an SWR meter indicates a perfect impedance match between the antenna and the feedline.

1.00 to 1.00 VSWR is not a guarantee that you have an effective antenna.

T7C05

The approximate SWR value above which the protection circuits in most solid-state transmitters begin to reduce transmitter power is **2 to 1**.

With a 2 to 1 mismatch the antenna will look like either 25 Ω or 100 Ω if the transmitter has a 50 Ω output impedance, Both represent a 2 to 1 mismatch.

T7C06

An SWR reading of 4:1 means you have **an impedance mismatch**.

In a 50 ohm system the load could be either 12.5 ohms or 200 ohms. Both would show a VSWR of 4:1

T7C07

The power lost in a feedline (such as coaxial cable) is **converted into heat**.

T7C08

Another instrument other than an SWR meter could be used to determine if a feedline and antenna are properly matched is a **directional wattmeter**.



T7C09 (A)

Moisture contamination is the most common cause for failure of coaxial cables.

T7C10

The outer jacket of coaxial cable should be resistant to ultraviolet light because **ultraviolet light can damage the jacket and allow water to enter the cable**.

T7C11

A disadvantage of "air core" coaxial cable when compared to foam or solid dielectric types is that **it requires special techniques to prevent water absorption**.

But the advantage is that it will have less loss at higher frequencies

T7D – Basic repair and testing; soldering, use of a voltmeter, ammeter, and ohmmeter

T7D01 (B)

A **voltmeter** would be used to measure electric potential or electromotive force.



T7D02

The correct way to connect a voltmeter to a circuit is **in parallel with the circuit**.

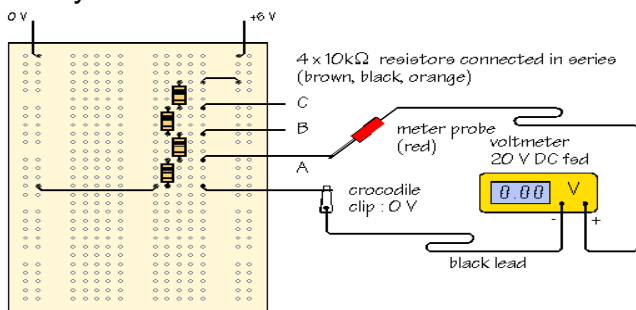

T7D03

An ammeter usually connected **in series with the circuit**.

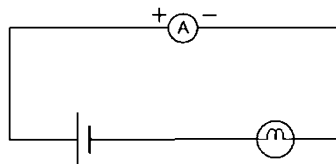

Fig. 5.13 Ammeter in a circuit

T7D04

An **ammeter** is used to measure electric current.

T7D05

An **ohmmeter** is used to measure resistance.

T7D06

Attempting to measure voltage when using the resistance setting might damage a multimeter.

T7D07

Voltage and resistance measurements are commonly made using a multimeter.

T7D08

Rosin-core solder solder is best for radio and electronic use.

Never use acid core solder on electronic circuits, the connection will eventually fail as the acid corrodes the connection.

T7D09 appearance of a "cold" solder joint is **a grainy or dull surface**.

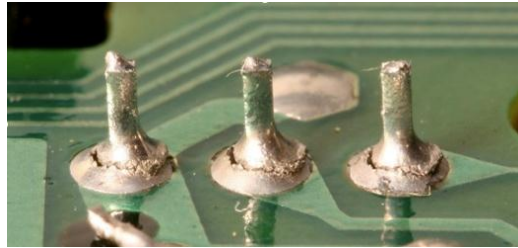
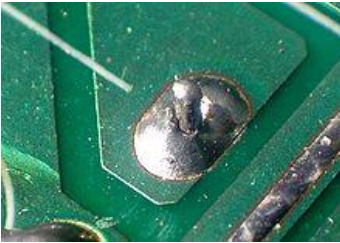

T7D10

What is probably happening when an ohmmeter, connected across a circuit, initially indicates a low resistance and then shows increasing resistance with time is that **the circuit contains a large capacitor**.

T7D11

When using ohmmeter precautions should be taken when measuring circuit resistance to **ensure that the circuit is not powered**.

Also insure that there are no charged capacitor's in the circuit after the power is disconnected from the circuit you are measuring.

SUBELEMENT T8 –

Modulation modes; amateur satellite operation, operating activities, non-voice communications – [4 Exam Questions - 4 Groups]

T8A – Modulation modes; bandwidth of various signals

T8A01

Single sideband is a form of amplitude modulation.

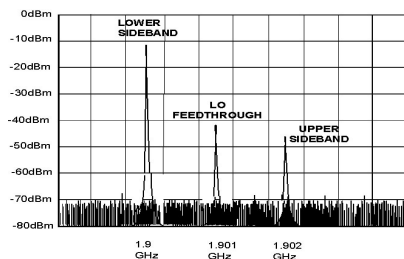

T8A02

FM modulation is most commonly used for VHF packet radio transmissions.

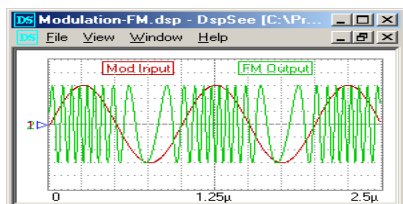

T8A03

SSB voice modulation is most often used for long-distance or weak signal contacts on the VHF and UHF bands.

T8A04

FM modulation is most commonly used for VHF and UHF voice repeaters.

T8A05

CW has the narrowest bandwidth when compared to FM voice, SSB Voice and slow scan TV.

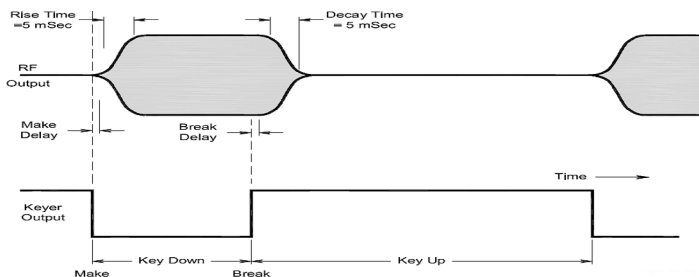

T8A06 (A)

Upper sideband is normally used for 10 meter HF, VHF and UHF single-sideband communications.

*As a **general rule and practice** lower sideband (LSB) is used for frequencies below 10 MHz and upper sideband (USB) is used for frequencies above 10 MHz .*

T8A07

The primary advantage of single sideband over FM for voice transmissions is that **SSB signals have narrower bandwidth.**

T8A08

The approximate bandwidth of a single sideband voice signal is **3 KHz.**

T8A09

The approximate bandwidth of a VHF repeater FM phone signal is **Between 5 and 15 kHz.**

With a deviation of 5 KHz there would be a frequency spread from -5 KHz to + 5 KHz, adding the maximum audio frequency of 2.8 KHz to each side we would -7.8 KHz to + 7.8 KHz for a total occupied bandwidth of 15.6 KHz. This maximum would occur when speaking very loudly into the microphone. Speaking softly you would have much less occupied bandwidth.

T8A10

The typical bandwidth of analog fast-scan TV transmissions on the 70 cm band is **about 6 MHz.**

T8A11

The approximate maximum bandwidth required to transmit a CW signal is **150 Hz.**

T8B - Amateur satellite operation; Doppler shift, basic orbits, operating protocols

T8B01

Any amateur whose license privileges allow them to transmit on the satellite uplink frequency may be the control operator of a station communicating through an amateur satellite or space station.

T8B02 [97.313(a)]

The transmitter power used on the uplink frequency of an amateur satellite or space station should be **the minimum amount of power needed to complete the contact.**

T8B03

Using an amateur radio satellite you can **talk to amateur radio operators in other countries**

T8B04

Any amateur holding a Technician or higher class license may make contact with the amateur station on the International Space Station using two meter and 70 cm band amateur radio frequencies.

T8B05

A satellite beacon **is a transmission from a space station that contains information about a satellite.**

T8B06

A satellite tracking program can be used to determine the time period during which an amateur satellite or space station can be accessed.

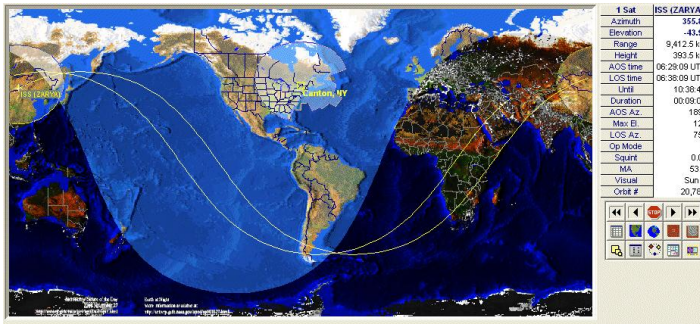

T8B07

With regard to satellite communications, Doppler shift is **an observed change in signal frequency caused by relative motion between the satellite and the earth station.**

Doppler makes the signal from an approaching satellite appear higher and as it moves away from you it will appear lower in frequency. You will experience this effect as the whistle of an approaching train changes pitch as it passes you.

T8B08

The statement that a satellite is operating in "mode U/V+ means **the satellite uplink is in the 70 cm band (UHF) and the downlink is in the 2 meter band (VHF).**

T8B09

Rotation of the satellite and its antennas causes "spin fading" when referring to satellite signals.

This is because the antenna polarization is continuously changing due to the rotation.

T8B10

The initials LEO referenced to an amateur radio satellite tells you **the satellite is in a Low Earth Orbit**

T8B11

FM Packet is a commonly used method of sending signals to and from a digital satellite.

T8C – Operating activities; radio direction finding, radio control, contests, special event stations, basic linking over Internet

T8C01

Radio direction finding is used to locate sources of noise interference or jamming.



T8C02

A directional antenna would be useful for a hidden transmitter hunt.

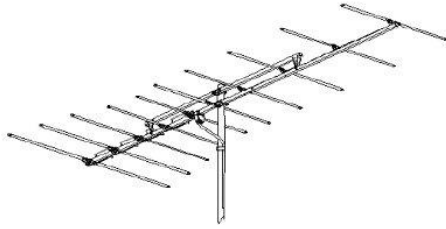

T8C03

Contesting is popular operating activity that involves contacting as many stations as possible during a specified period of time.

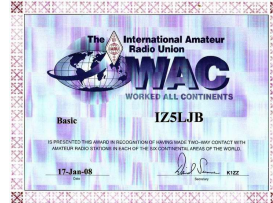

T8C04

It is good procedure when contacting another station in a radio contest to **send only the minimum information needed for proper identification and the contest exchange.**

T8C05

A grid locator is a **letter-number designator assigned to a geographic location.**



T8C06

A temporary "1 by 1" format (letter-number-letter) call sign can be assigned **for operations in conjunction with an activity of special significance to the amateur community**

T8C07 [97.215(c)]

The maximum power allowed when transmitting telecommand signals to radio controlled models is **1 watt.**

T8C08 [97.215(a)]

In place of on-air station identification when sending signals to a radio control model using amateur frequencies **a label indicating the licensee's name, call sign and address must be affixed to the transmitter.**

T8C09

You can obtain a list of active nodes that use VoIP **from a repeater directory.**



T8D03

A Global Positioning System receiver is normally used when sending automatic location reports via amateur radio.

T8D04

An analog fast scan color TV signal type of transmission is indicated by the term NTSC.

National Television System Committee

T8D05

Data mode emission may be used by a Technician Class operator between 219 and 220 MHz.

T8D06

The abbreviation PSK means **Phase Shift Keying**.

T8D07

PSK31 is a **low-rate data transmission mode**.

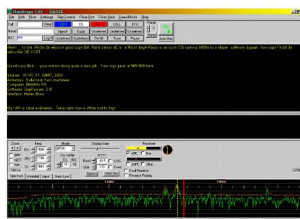

T8D08

A check sum which permits error detection, a header which contains the call sign of the station to which the information is being sent and an automatic repeat request in case of error may be included in packet transmissions.

T8D09

International Morse code is used when sending CW in the amateur bands.

T8D10

A straight Key, electronic keyer or computer Keyboard can be used to transmit CW in the amateur bands.

T8D11

A "parity" bit is **an extra code element used to detect errors in received data**.

**SUBELEMENT T9 –
Antennas, feedlines - [2 Exam Questions - 2 Groups]**

T9A – Antennas; vertical and horizontal, concept of gain, common portable and mobile antennas, relationships between antenna length and frequency

T9A01

A beam antenna is **an antenna that concentrates signals in one direction.**

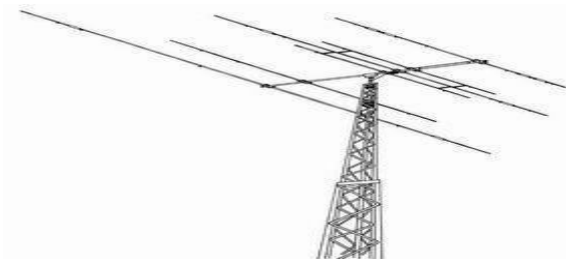

T9A02

A vertical antenna has **the electric field is perpendicular to the Earth.**

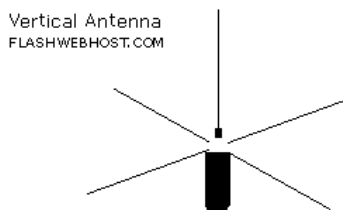

T9A03

A simple dipole mounted so the conductor is parallel to the Earth's surface is **a horizontally polarized antenna**

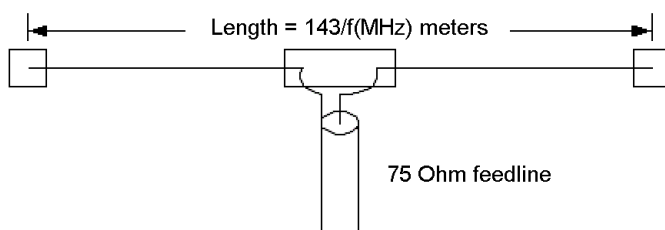

T9A04 A disadvantage of the "rubber duck" antenna supplied with most handheld radio transceivers is that **it does not transmit or receive as effectively as a full-sized antenna.**

T9A05

To change a dipole antenna to make it resonant on a higher frequency you would **shorten it.**

T9A06

The quad, Yagi, and dish antennas are all **Directional antennas**.

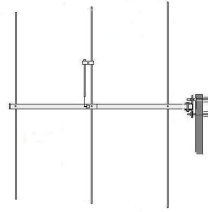
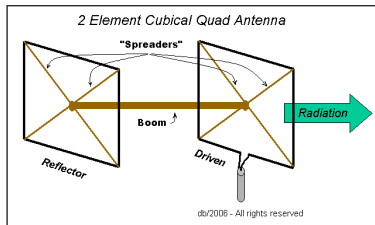

T9A07

A good reason not to use a "rubber duck" antenna inside your car is that **signals can be significantly weaker than when it is outside of the vehicle**.

T9A08

The approximate length, in inches, of a quarter-wavelength vertical antenna for 146 MHz is **19 inches**.

$1/4 \lambda = (300 / 146) / 4$ or $\lambda = (2.0548) / 4$ or $.5137$ Meters
Dividing by $.0254$ to convert to inches $.5137 / .0254$ or 20.22 inches
The closest answer choice is **19 inches**.

T9A09

The approximate length, in inches, of a 6 meter 1/2-wavelength wire dipole antenna is **112 Inches**.

$\lambda = 300 / 52 \text{MHz}$ or wavelength = 5.7692 Meters
A dipole is $1/2 \lambda$ or 2.8846 meters
 $1 \text{ inch} = 0.0254$ meters
 $2.8846 / 0.0254 = 113.567$ Inches

The closest answer in the choices is 112 inches

T9A10

The radiation strongest from a half-wave dipole antenna in free space is **broadside to the antenna**.

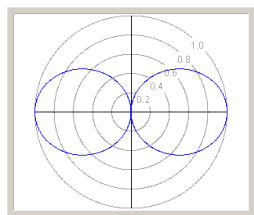

T9A11

The gain of an antenna is **the increase in signal strength in a specified direction when compared to a reference antenna**.

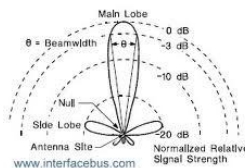

T9B - Feedlines; types, losses vs. frequency, SWR concepts, matching weather protection, connectors

T9B01

It is important to have a low SWR in an antenna system that uses coaxial cable feedline **to allow the efficient transfer of power and reduce losses.**

T9B02

The impedance of the most commonly used coaxial cable in typical amateur radio installations is **50 ohms.**

Cable TV cable is typically 75 ohms.

T9B03

Coaxial cable is used more often than any other feedline for amateur radio antenna systems because **it is easy to use and requires few special installation considerations.**

T9B04

An antenna tuner **matches the antenna system impedance to the transceiver's output impedance.**

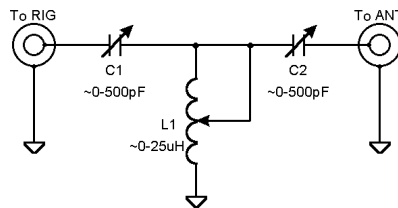

T9B05

As the frequency of a signal passing through coaxial cable is increased **the loss increases.**

T9B06

A Type N connector is most suitable for frequencies above 400 MHz.



T9B07

PL-259 type coax connectors **are commonly used at HF frequencies.**



T9B08

Coax connectors exposed to the weather be must sealed against water intrusion **to prevent an increase in feedline loss.**

T9B09

A loose connection in an antenna or a feedline might cause erratic changes in SWR readings.

T9B10

The electrical difference between the smaller RG-58 and larger RG-8 coaxial cables is that **RG-8 cable has less loss at a given frequency.**

Attenuation (dB per 100 feet)										
	MHz:	30	50	100	146	150	440	450	1000	2400
#2632	RG-174	5.5	6.6	8.8	13.0		25.0		30.0	75.0
#0985	LMR-100A®	3.9	5.1		8.8	8.9	15.6	15.8		
#2619	RG-58A/U	2.5	4.1	5.3	6.1	6.1	10.4	10.6	24.0	38.9
#3603	LMR-200®	1.8	2.3		3.9	4.0	6.9	7.0		16.5
#2910	RG-59		2.4	3.5			7.6		12.0	
#2247	RG-8X	2.0	2.1	3.0	4.5	4.7	8.1	8.6		21.6

T9B11

Air-insulated hard line type of feedline has the lowest loss at VHF and UHF.

SUBELEMENT T0 –

AC power circuits, antenna installation, RF hazards – [3 Exam Questions - 3 Groups]

T0A – AC power circuits; hazardous voltages, fuses and circuit breakers, grounding, lightning protection, battery safety, electrical code compliance

T0A01

A commonly accepted value for the lowest voltage that can cause a dangerous electric shock is 30 volts.

T0A02

Current flowing through the body is a health hazard because it causes **heating in tissue, disrupts the electrical functions of cells and causes involuntary muscle contractions.**

T0A03

Safety ground is connected to the green wire in a three-wire electrical AC plug.

T0A04

The purpose of a fuse in an electrical circuit is **to interrupt power in case of overload.**

T0A05

It not a good idea to install a 20-ampere fuse in the place of a 5-ampere fuse because it would allow **excessive current flow, and could cause a fire.**

T0A06

A good way to guard against electrical shock at your station is to:

- **Use three-wire cords and plugs for all AC powered equipment**
- **Connect all AC powered station equipment to a common safety ground**
- **Use a circuit protected by a ground-fault interrupter**

T0A07

When installing devices for lightning protection in a coaxial cable feedline ground **all of the protectors to a common plate which is in turn connected to an external ground.**

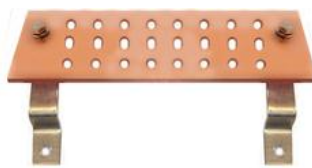

T0A08

One way to recharge a 12-volt lead-acid station battery if the commercial power is out is to **connect the battery to a car's battery and run the engine.**

T0A09

one kind of hazard is presented by a conventional 12-volt storage battery is that **explosive gas can collect if not properly vented,**



T0A10

If a lead-acid storage battery is charged or discharged too quickly **the battery could overheat and give off flammable gas or explode.**

T0A11

It is good practice when installing ground wires on a tower for lightning protection **ensure that connections are short and direct.**

T0A12

A hazard that might exist in a power supply when it is turned off and disconnected is that **you might receive an electric shock from stored charge in large capacitors.**

T0A13

A fuse or circuit breaker in series with the AC "hot" conductor should always be included for safety in home-built equipment that is powered from 120V AC power circuits.

T0B – Antenna installation; tower safety, overhead power lines

T0B01

Members of a tower work team should wear a hard hat and safety glasses **at all times when any work is being done on the tower**

T0B02

A good precaution to observe before climbing an antenna tower would be to **put on a climbing harness and safety glasses.**

T0B03

It is **never** safe to climb a tower without a helper or observer.

T0B04

An important safety precaution to observe when putting up an antenna tower is to **look for and stay clear of any overhead electrical wires.**

T0B05

The purpose of a gin pole is **to lift tower sections or antennas.**

T0B06

The minimum safe distance from a power line to allow when installing an antenna would be **so that if the antenna falls unexpectedly, no part of it can come closer than 10 feet to the power wires.**

T0B07

An important safety rule to remember when using a crank-up tower is **this type of tower must never be climbed unless it is in the fully retracted position.**

T0B08

The proper grounding method for a tower would be **separate eight-foot long ground rods for each tower leg, bonded to the tower and each other.**



T0B09

You should avoid attaching an antenna to a utility pole because **the antenna could contact high-voltage power wires.**

And it is illegal. The power company may remove your antenna or supports and charge you for their service.

T0B10

Sharp bends must be avoided in grounding conductors used for lightning protection.

T0B11

Local electrical codes establish grounding requirements for an amateur radio tower or antenna.

T0C - RF hazards; radiation exposure, proximity to antennas, recognized safe power levels, exposure to others

T0C01

The type of radiation from VHF and UHF radio signals is **Non-ionizing radiation.**

Ionizing radiation is radiation with enough energy so that during an interaction with an atom, it can remove tightly bound electrons from the orbit of an atom, causing the atom to become charged or ionized.

T0C02

The **50 MHz** (6 meter) band has the lowest Maximum Permissible Exposure limit.

T0C03

The maximum power level that an amateur radio station may use at VHF frequencies before an RF exposure evaluation is required is **50 watts PEP at the antenna.**

See table on page 66

T0C04

The factors that affect the RF exposure of people near an amateur station antenna are

- **Frequency and power level of the RF field**
- **Distance from the antenna to a person**
- **Radiation pattern of the antenna**

T0C05

Exposure limits vary with frequency because **the human body absorbs more RF energy at some frequencies than at others.**

T0C06 (D)

The following are acceptable methods to determine that your station complies with FCC RF exposure regulations.

- **By calculation based on FCC OET Bulletin 65**
- **By calculation based on computer modeling**
- **By measurement of field strength using calibrated equipment**

T0C07

If a person accidentally touched your antenna while you were transmitting **they might receive a painful RF burn**

T0C08

An action amateur operators might take to prevent exposure to RF radiation in excess of FCC-supplied limits is to **relocate antennas.**

T0C09

You can make sure your station stays in compliance with RF safety regulations **by re-evaluating the station whenever an item of equipment is changed.**

T0C10

Duty cycle is one of the factors used to determine safe RF radiation exposure levels **because it affects the average exposure of people to radiation.**

T0C11

The "duty cycle", when referring to RF exposure, is **the ratio of on-air time to total operating time of a transmitted signal.**



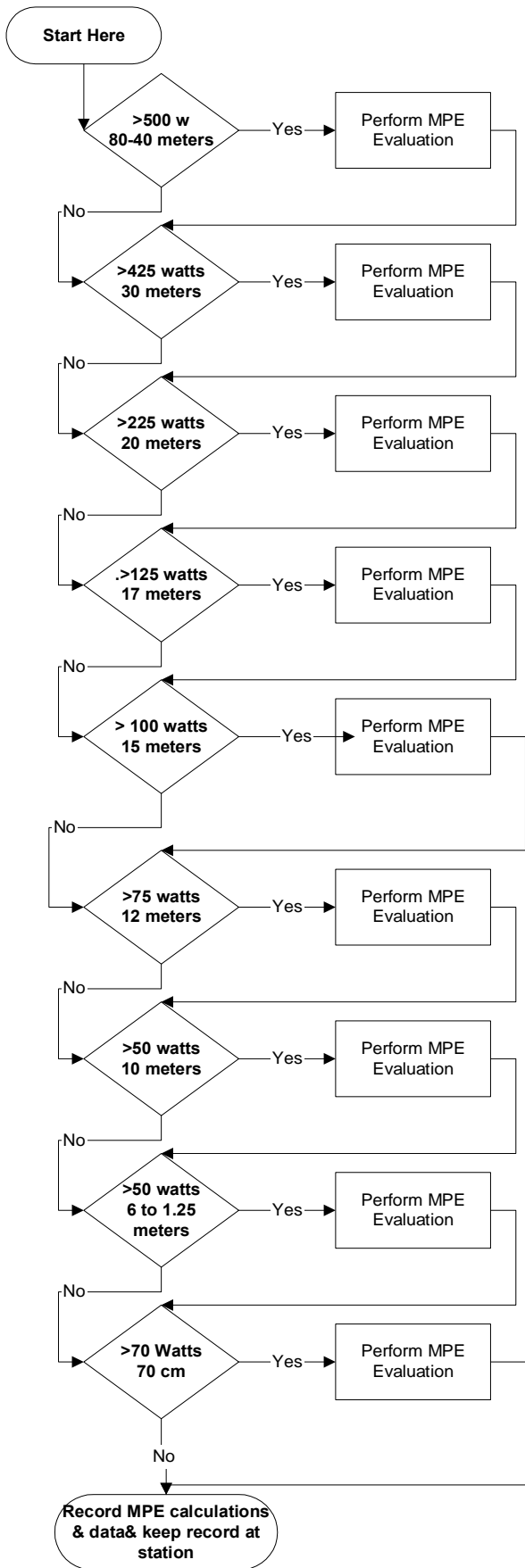

Note- Decision for running MPE at any specific frequency is determined by the ERP which is the transmitter output power plus antenna gain minus any feed line losses, filter or other losses

Example: The ERP for a 200 watt transmitter on 80 meters with an antenna gain of 9dB, feedline loss of 1.5 dB and a band pass filter with a loss of 1.5 dB would have an ERP of 800 watts and would require an MPE evaluation

MPE = 200 watts +9dB -1.5 dB -1.5 dB or 200 watts with +6db of gain. #db would be 2 times the power and an additional 3db to make 6 db would be times 2 again for a total of times 4. With the 200 watt input the ERP would be 4 x 200 or 800 watts. An MPE evaluation would be required

Appendix

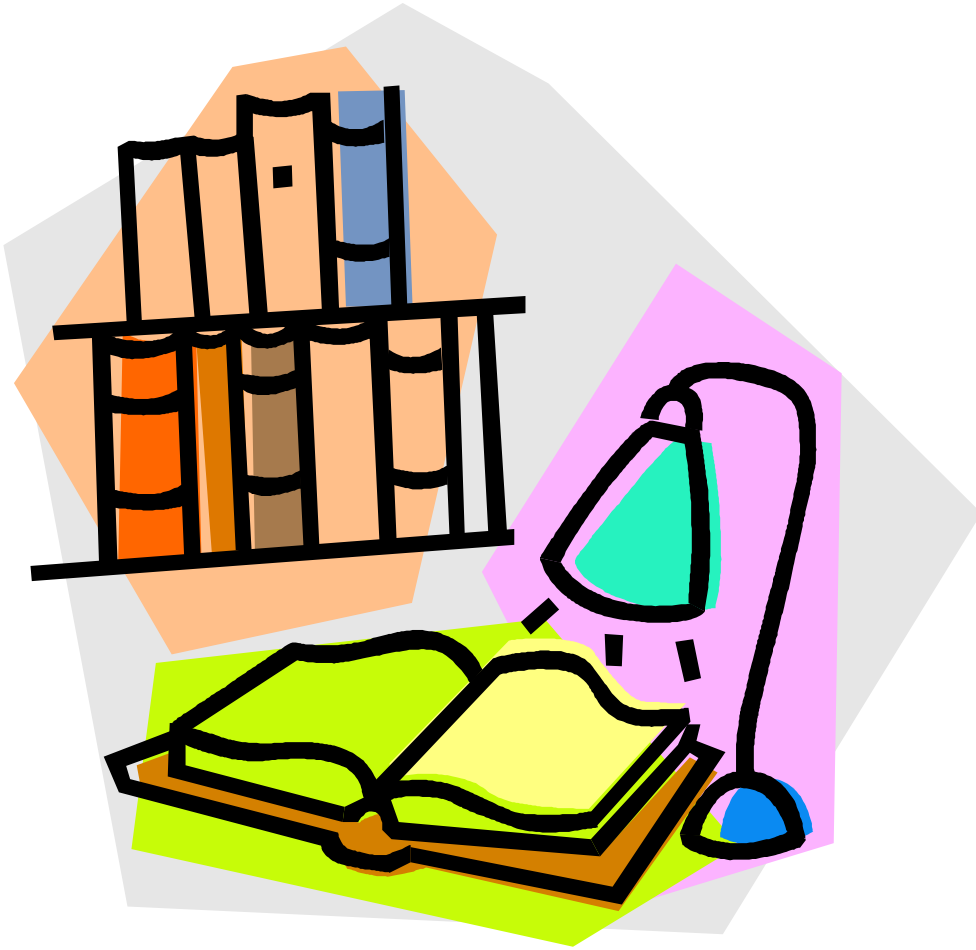

International System of Units (SI)—Metric Units

Prefix	Symbol	Multiplication Factor
exe	E	10^{+18} 1,000,000 000,000,000,000
peta	P	10^{+15} 1,000 000,000,000,000
tera	T	10^{+12} 1,000,000,000,000
giga	G	10^{+9} 1,000,000,000
mega	M	10^{+6} 1,000,000
kilo	k	10^{+3} 1,000
hecto	h	10^{+2} 100
deca	da	10^{+1} 10
(unit)		10^{+0} 1
deci	d	10^{-1} 0.1
centi	c	10^{-2} 0.01
milli	m	10^{-3} 0.001
micro		10^{-6} 0.000001
nano	n	10^{-9} 0.000000001
pico	p	10^{-12} 0.000000000001
femto	f	10^{-15} 0.000000000000001
atto	a	10^{-18} 0.000000000000000001

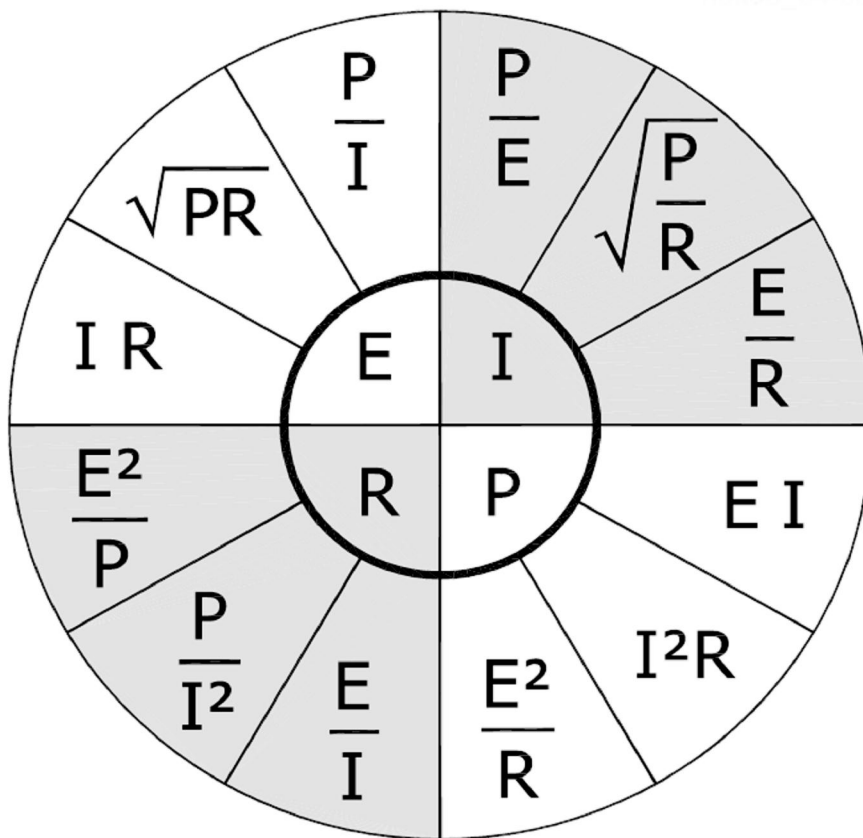

Ohms Law Circle

Scientific Notation to component values

Milli	m= .001 or	1x 10 ⁻³
Micro	μ = .000,001 or	1x 10 ⁻⁶
Nano	n= .000,000,001 or	1 x 10 ⁻⁹
Pico	p= .000,000,000,001 or	1 x 10 ⁻¹²
Femto	f= .000,000,000,000,001 or	1 x 10 ⁻¹⁵

Ohms Law

$$I=E/R \quad R=E/I \quad E=I * R \quad (\text{Amperes ó Volts-Ohms})$$

$$P=E * I \quad P= E^2 /R \quad I= P/E \quad (\text{amperes-volts-ohms-watts})$$

Series connected Resistors

$$R = R1 + R2 + R3 + Rx$$

Parallel connected Resistors

$$R = \frac{1}{\frac{1}{R1} + \frac{1}{R2} + \frac{1}{R3} + \dots + \frac{1}{Rx}}$$

Series inductors

$$\text{Total Inductance} = L1 + L2 + L3 + Lx$$

Parallel inductors

$$L = \frac{1}{\frac{1}{L1} + \frac{1}{L2} + \frac{1}{L3} + \dots + \frac{1}{Lx}}$$

Capicitors in parallel

$$C = C1 + C2 + C3 + Cx$$

Capacitors in series

$$C = \frac{1}{\frac{1}{C1} + \frac{1}{C2} + \frac{1}{C3} + \dots + \frac{1}{Cx}}$$

Effective Radiated Power

Lets take an example with the following characteristics:

Power output from radio = **50 watts**

Feed line loss = **- 4dB**

Duplexer loss = **-2 dB**

Circulator loss = **- 1dB**

Antenna Gain =+ **4 dB**

We calculate the overall ERP as follows:

$$ERP = \text{Transmitter Power Out} = +((-4)+(-2)+(-1)+(4)) = 50 - 3 \text{ dB or } 25 \text{ watts}$$

Transmitter Power Measurements

The PEP power output for a transmitter with an observed 30 volt peak envelope voltage (as seen on an oscilloscope) would be 9 watts. To determent the PEP power we take the peak voltage and multiply it by $\sqrt{0.707}$ to get the Peak RMS voltage then using the Peak RMS voltage we calculate power using the equation $P(\text{watts}) = V(\text{RMS})^2 / R (\text{load})$

$$PEP (\text{watts}) = [V(\text{peak}) \times .707]^2 / \text{Load Resistance}$$

$$\text{PEP (watts)} = [V(\text{peak}) \times .707]^2 / 50 = (21.2)^2 / 50 = 449 / 50 = 9$$

Amplifier efficiency

Amplifier efficiency is the ratio of power divided by power input times 100%.

$$\text{Efficiency} = P(\text{out}) / P(\text{input}) \times 100$$

A typical 1500 Watt PEP class B amplifier will require 2500 watts of DC input power (assume 60% efficiency). A typical class A amplifier will be typically 25 to 35% efficient.

$$P(\text{input}) = P(\text{output}) / \text{Efficiently} = 1500 \text{ Watts} / .60 = 2500 \text{ Watts}$$

Common Q signals

QRB	<i>How far are you from my station?</i>
QRK	<i>What is the readability of my signal?</i>
QRL	<i>are you busy? / Is this frequency in use?</i>
QRM	<i>Are you being interfered with?</i>
QRP	<i>Shall I decrease power?</i>
QRV	<i>Are you ready?</i>
QTH	<i>What is your location?</i>
QTR	<i>What is the correct time?</i>
QSK	<i>Full break in telegraphy</i>
QRQ	<i>Send Faster</i>
QRS	<i>Send slower</i>
QRV	<i>I am ready to receive</i>
QRZ	<i>Who is calling me?</i>
QSL	<i>Can you acknowledge receipt?</i>
QSY	<i>Shall I change to another frequency?</i>

A complete list of Q signals can be found at http://bclingan.org/mainpage_000012.htm