

LA VOZ

BILINGÜE

Member National Association of Hispanic Publications

Member Colorado Press Association

Media Kit 2016



**CIRCULATION/
DEMOGRAPHIC
CIRCULACIÓN/
DEMOGRÁFICA**

Reaching 120,000 readers in print and thousands online.

Follow us on:

- Facebook
- Twitter

2

**CALENDAR
CALENDARIO**

A year at a glance including Earth Day, Cinco de Mayo, Hispanic Heritage Month & more

3

**RATE CARD
TARIFA**

Affordable rates

- Display
- Online
- Classifieds
- Service Directory
- Bundled Packages

4

**WEBSITE
LA RED**

Thousands of online visitors.
Recipient of the 2014 NAHP Gold award

www.lavozcolorado.com

7

DE LA EDITORA

Estamos orgullosos de los logros de nuestro personal de La Voz en el 2015. Estos logros le ayudan al anunciante a llegar a su mercado y lograr sus metas.

La Voz, publicación bilingüe #1 de Colorado propiedad hispana, fue la ÚNICA publicación bilingüe/sólo en español de los medio impresos, que obtuvo una entrevista exclusiva con el presidente Obama, consolidando el poder del voto latino y la influencia y el alcance de nuestra publicación bilingüe en sus 42 años. Además, nuestro personal fue premiado con 15 premios de la Asociación Nacional de Publicaciones Hispanas (NAHP por sus siglas en inglés) en la convención en Dallas.

¡Vamos a trabajar juntos en el 2016 para lograr nuestros objetivos comunes!

FROM THE PUBLISHER

We are proud of the accomplishments of our La Voz staff in 2015. These accomplishments help you the advertiser reach your market and achieve your goals.

La Voz, Colorado's #1 Hispanic-owned bilingual publication, was the ONLY bilingual/Spanish-only print media to land an EXCLUSIVE interview with President Obama, cementing the power of the Latino vote and the influence and reach of our 42-year-old, bilingual publication. Furthermore, our award-winning staff garnered 15 awards at the National Association of Hispanic Publications (NAHP) at the Dallas convention.

Let's work together in 2016 to achieve our mutual goals!

AREA OF CIRCULATION

- ◆ 32,000 Audited Total Circulation
- ◆ 120,000 Weekly Readership

Source: Dec. 2015, Certified Audit of Circulation

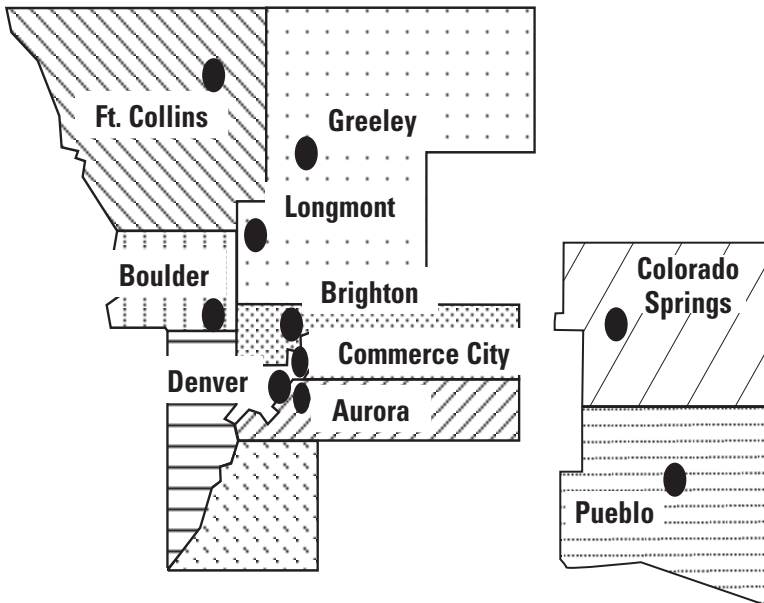

METRO DENVER / FRONT RANGE

County	Latino Population 2014	Number of copies
Denver	204,470	13,850
Adams	186,519	7,940
Arapahoe	116,339	1,035
Jefferson	84,893	1,750
Boulder	43,240	1,580
Broomfield	7,455	435
Weld	79,969	1,970
Larimer	35,977	350
Pueblo	68,797	2,100
El Paso	108,154	1,000
Total	935,813	32,000

The Denver Latino Market

- ◆ One of the fastest growing markets in the USA*
- ◆ A \$1.2 trillion+ disposable income*

Source: Ad Age

ABOUT OUR READERS

Average age: 38
 83% prefer La Voz Bilingüe as their information source
 33% prefer to read in English
 33% prefer to read in Spanish
 33% read in both Spanish and English
 Average income: \$53,000

Source: 2009 Western Publications Research Group

EDITORIAL CONTENT

La Voz Bilingüe is Colorado's most widely read bilingual newspaper, publishing a high quality news product focusing on Latinos. We cover the

news from a local/national perspective in a bilingual format. We cater to readers of a society diverse in its language, culture and politics. Our award winning

coverage of community affairs, education, business, government, health, arts, entertainment and sports surpasses the competition.

2016 Edition Schedule

January	February	March	April
6	3	2	6
13 Stock Show Coverage	10 Valentine's Day <i>Día de San Valentín</i>	9	13 Tax Issue
20 Invest in Colorado	17 Lenten Issue <i>Edición de Cuaresma</i>	16 St. Patrick's Day <i>Día de San Patricio</i>	20 Earth Day <i>Día de la Tierra</i>
27	24	23 Easter <i>Edición de Pascua</i>	27 Children's Day <i>Día del Niño</i>
		30	

LA VIDA LATINA

On top of what's happening in the arts, theatre, music and film.

COMMUNITY COMUNIDAD

Always a part of LA VOZ - from civic and professional organizations to education and health.

May	June	July	August
4 Coverage of Cinco/ Mother's Day <i>Cobertura del Cinco de Mayo/Día de las Madres</i>	1 Graduation/Careers <i>Graduación/Carreras Brides/Novias</i>	6 4th of July <i>Cuatro de Julio</i>	3 Labor Day Issue <i>Edición para el día del trabajo</i>
11	8 Student of the Week Winner Announced Father's Day <i>Día del Padre</i>	13 Summer fun <i>Vacaciones de Verano</i>	10 Education Special Issue <i>Edición Educativa</i>
18 Memorial Day <i>Día de la conmemoración</i>	15	20	17
25	22	27 Senior Citizens <i>Edad Dorada</i>	23
	29		30

STUDENT OF THE WEEK

Honoring our best and brightest students and rewarding those who excel.

RECOLLECTIONS MIS RECUERDOS

Pauline Rivera draws upon her experiences in New Mexico and Colorado to reminisce about the glories and pitfalls of growing up Latina, with humor and insight.

September	October	November	December
7	5 SOTW Kickoff	2	7 Virgin of Guadalupe <i>La Virgen de Guadalupe</i>
14 Hispanic Heritage <i>La Herencia Hispana</i> (9/10 - 10/15)	12	9 Veterans Day <i>Día de los Veteranos</i>	14
21 Coverage of Fiestas <i>Patrias Cobertura de las Fiestas</i>	19	16 Unique Gifts <i>Regalos Únicos</i> (11/23 - 12/21)	21 Holiday Issue <i>Edición de las Fiestas</i>
28	26 Halloween Issue <i>Día de los Muertos</i>	23 Thanksgiving <i>Día de Acción de Gracias</i>	28 Year End Review <i>Revisión de Fin de Año</i>
		30	

SPORTS DEPORTES

Coverage of Colorado teams - The Rockies, Rapids, Broncos and Nuggets along with prep sports, celebrating Colorado's penchant for the outdoors.



¿Que Pasa? What's happening?

EVENTS CALENDAR

2016 Display ad rates/specs

For rates, contact
Advertising@lavozcolorado.com

PREPRINTED INSERTS: \$75/1000
 (To be delivered to Printer)

CREATIVE SERVICES

Design \$30 PER HOUR
 Translation \$25 PER HALF HOUR

Space Deadline Friday 4:00 P.M.

Acceptable Files and Formats

PDF (most compatible format);
 Illustrator eps; Photoshop tif,
 jpeg and Microsoft Word.
 (Corel Draw, Word Perfect &
 Publisher excluded)

La Voz is a 6 column by 14 inch
 short tabloid newspaper. Each

column is 9½ picas (1.58")
 wide, making a full page ad
 62 picas (10.33") wide by 14"
 deep.

The following chart is a guide
 for sizing smaller ads on a
 regular 6 column by 14" full
 page layout.

* **Back Page & Centerfold Banner must purchase full color**

La Voz column width chart

1.5 columns:	No longer available	
2 columns:	20 picas	3.33 inches
3 columns:	30.5 picas	5.08 inches
4 columns:	41 picas	6.83 inches
4.5 columns:	46.25 picas	7.71 inches
6 columns:	62 picas	10.33 inches

Artwork deadline: Monday 12:00 P.M.

Measurements & Specs

Full page (84") options

vertical only: 6 columns (10.33") by 14 inches deep

3/4 page (63") options

* vertical: 4.5 columns (7.71") by 14 inches deep
 horizontal: 6 columns (10.33") by 10.5 inches deep

1/2 page (42") options

vertical: 3 columns (5.08") by 14 inches deep
 vertical: 4 columns (6.83") by 10.5 inches deep
 * horizontal: 6 columns (10.33") by 7 inches deep

1/4 page (21") options

* vertical: 3 columns (5.08") by 7 inches deep
 horizontal: 4 columns (6.83") by 5.25 inches deep
 banner: 6 column (10.33") by 3.5 inches deep

1/8 page (12") options

vertical: 2 columns (3.33") by 6 inches deep
 * horizontal: 3 columns (5.08") by 4 inches deep
 banner: 6 column (10.33") by 2 inches deep

* Most popular format

BILLING INFORMATION

Client/Company _____

Billing Name _____

Advertising Agency _____

Address _____

City _____ State _____ Zip _____

Phone _____ Fax _____

Email _____

Width _____ x Height _____ = Total col. inches _____
(columns) (inches)

Rate \$ _____ x Total _____ = Price per ad \$ _____
(per column inch) (column inches)

Discounts _____ = Price reduction -\$ _____

Color & charge _____ = Price \$ _____

Weekly Total \$ _____ x Insertions _____ = Total \$ _____

Additional Services _____ = Price \$ _____

GRAND TOTAL \$ _____

INSERTION DATES

2016 INSERTIONS					2017 INSERTIONS				
JAN	6	13	20	27	JAN	4	11	18	25
FEB	3	10	17	24	FEB	1	8	15	22
MAR	2	9	16	23 30	MAR	1	8	15	22 29
APR	6	13	20	27	APR	5	12	19	26
MAY	4	11	18	25	MAY	3	10	17	24 31
JUN	1	8	15	22 29	JUN	7	14	21	28
JUL	6	13	20	27	JUL	5	12	19	26
AUG	3	10	17	24 31	AUG	2	9	16	23 30
SEP	7	14	21	28	SEP	6	13	20	27
OCT	5	12	19	26	OCT	4	11	18	25
NOV	2	9	16	23 30	NOV	1	8	15	22 29
DEC	7	14	21	28	DEC	6	13	20	27

SPECIFIC CONDITIONS - PLEASE READ CAREFULLY

- The authorizing person approves the above advertising, dates, rate, and contracts with La Voz Publishing, Inc./dba La Voz Bilingüe to perform the stated work.
- All advertising copy submitted hereunder is subject to approval revision or rejection by the Publisher. The Publisher reserves the right to edit, revise and approve all Spanish text. To be binding upon the Publisher, all instructions relative to the advertising must be given in writing.
- Should customer fail to make payment for work as agreed, La Voz Publishing, Inc./dba La Voz Bilingüe may cancel and terminate this order and customer shall pay for work performed at the open-rate or the stated rate, whichever is higher.
- No display advertising under this contract will be accepted in any amount less than four column inches. The basis of measurement for display and classified advertising is the column inch.
- This order will not be invalidated by insertions in wrong location or by omissions and errors and credit will be given only for space occupied by the error.
- La Voz Publishing, Inc./dba La Voz Bilingüe will not be liable for any errors unless corrections for

errors which arose are submitted in writing, and plainly noted within 5 days following publication. In any case, liability shall not exceed the cost of the single ad error.

7. Payments for advertisements are due upon receipt of bill, unless other arrangements have been made. All accounts over 30 days old are subject to 1 1/2% per month interest. (18% APR). In the event of nonpayment, the below signed agrees to pay all court costs and attorneys fees which results from action taken due to nonpayment.

8. Cancellation Clause: the advertiser may cancel

this contract any time during the effective period, provided the advertiser pays, in full, for all advertising space used under this contract, including the difference between the regular rates and the contract rate herein stated. Such cancellation notice must be received in writing.

9. Cancellation penalty regarding individual insertions: any ad must be cancelled on or before 5 p.m. the Friday before the ad is scheduled to run. Any ad cancelled after that time will be billed at 50% of the cost of the space reserved.

Accountable Party _____ Title _____

Signature _____ Date _____

PRODUCTION INFORMATION (FOR INTERNAL USE ONLY)

Client/Company _____

AD HEADLINE: _____

Width (columns) _____ x Height (inches) _____

Total col. inches _____ Weekly Total \$ _____

B&W BUILD ENGLISH
 SPOT COLOR CAMERA READY SPANISH
 4 COLOR TRANSLATION

Additional Notes: _____

METHOD OF PAYMENT (FOR INTERNAL USE ONLY)

WEEKLY CASH PREPAID CHECK
 MONTHLY CHECK # _____
 TOTAL CHARGE \$ _____



Card number: _____

Exp _____ / _____

Card holder name: _____

Address: _____

City: _____ State: _____ Zip: _____

Charge Amount \$ _____ Balance _____

Sizes, Direction & Measurements

Full Page

vertical only
6 columns (10.33") by
14 inches deep

3/4 Page

vertical
4.5 columns (7.71") by
14 inches deep

4 1/2 column

horizontal
6 columns (10.33") by
10.5 inches deep

6 column

1/2 Page

vertical
3 columns (5.08") by
14 inches deep

3 column

vertical
4 columns (6.83") by
10.5 inches deep

4 column

horizontal
6 columns (10.33") by
7 inches deep

6 column

**Classified Ads/
Service Directory**

For rates call
303-936-8556 x 240
or email
ClassSales@lavozcolorado.com

Examples

Full Page Ad
vertical only

3/4 Page Ad
vertical

horizontal

1/2 Page Ad
vertical

vertical

The plight of America's veterans

horizontal

Sizes, Direction & Measurements

1/4 Page

vertical
3 columns (5.08") by 7 inches deep

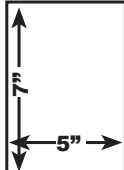

horizontal
4 columns (6.83") by 5.25 inches deep

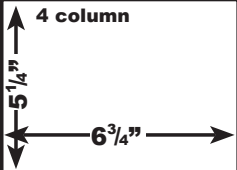

banner
6 columns (10.33") by 3.5 inches deep



Examples

1/4 Page vertical



3 columns x 7"

1/8 Page horizontal



2 columns x 6"

1/8 Page vertical
2 columns (3.33") by 6 inches deep



horizontal
3 columns (5.08") by 4 inches deep

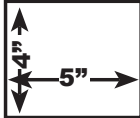

banner
6 column (10.33") by 2 inches deep

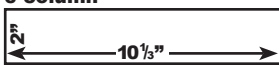

horizontal



4 columns x 5.25"

horizontal

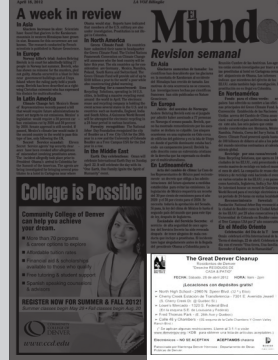

3 columns x 4"

banner



6 columns x 3.5"

banner



6 columns x 2"

Website/La Red

- Award-winning website
- Leader, tower online ads
- Award-winning editorial
- Like us on Facebook (Facebook.com/LaVozColorado)
- Follow us on Twitter (@LaVozColorado)