

Technical Information, December 2007

Overview of fire tests per country

GERMANY

DIN 4102, Teil 1 : Combustible building material

Class B1 building material

Combustible building materials are placed in class B1 if they pass the *Brandschacht* test, and satisfy the class B2 requirements.

Test specifications	
Specimen	4 specimens 190 x 1000 mm x original thickness
Specimen position	Vertical, samples at right angles to one other
Ignition source	Ring burner
Test duration	10 min.
Conclusions	Passed if <ul style="list-style-type: none"> - mean value of residual length is at least 150 mm ; residual length may not be 0 mm for any specimen - mean smoke gas temperature should not exceed 200°C - no other reservations exist.
Additional testing	If the filter paper under the sample ignites within 20 sec. after flaming, the material is judged to burn with flaming droplets.

Class B2 building material

Test specifications	
Specimen	Edge application of flame : 5 specimens 90 x 190 mm reference mark 150 mm from lower edge. Surface application of flame : 5 specimens 90 x 230 mm reference marks 40 and 190 mm from lower edge.
Specimen position	Vertical
Ignition source	Small burner, inclined at 45°, flame height 20 mm
Test duration	15 sec.
Conclusions	Passed if the tip of the flame does not reach the reference marks within 20 sec. on any sample for <i>edge application</i> of flame or, if failure is expected with this test, for <i>surface application of flame</i> .
Additional testing	If the filter paper under the sample ignites within 20 sec. after flaming, the material is judged to burn with flaming droplets.

Product liability clause: This information and our technical advice - whether verbal, in writing or by way of trials - are given in good faith but without warranty, and this also applies where proprietary rights of third parties are involved. Our advice does not release you from the obligation to verify the information currently provided - especially that contained in our safety data and technical information sheets - and to test products as to their suitability for the intended processes and uses. The application, use and processing of our products and the products manufactured by you on the basis of our technical advice are beyond our control and, therefore, entirely your own responsibility. Our products are sold in accordance with the current version of our General Conditions of Sale and Delivery.

Technical Information, December 2007

Overview of fire tests per country

GERMANY

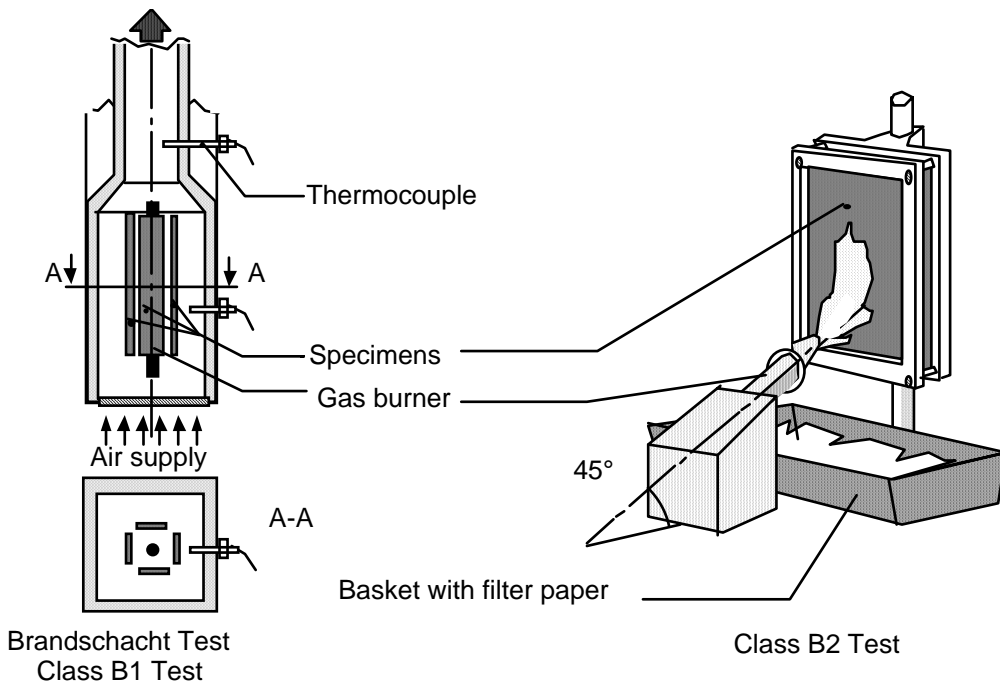

Technical Information, December 2007

Overview of fire tests per country

GREAT BRITAIN

Statutory regulations

The use and fire performance requirements of building materials and components are specified in the various building regulations, e.g. under "Structural Fire Precautions" - in Part E for England, Wales and Part D for Scotland. All the regulations are based on the same test methods specified in British Standards.

Classification and testing of the fire performance of building materials

The methods are described in British Standards BS 476, parts 3 to 8, and for certain special cases, in BS 2782 method 102 C. These Standards are issued by BSI, 2 Park Street, London W1A 2BS

BS 476 "Fire Tests on Building Materials and Structures" consists of:

- Part 3 : External Fire Exposure Roof Test
- Part 4 : Non-Combustibility Test for Materials
- Part 5 : Method of Test for Ignitability
- Part 6 : Fire Propagation Test for Materials
- Part 7 : Surface Spread of Flame
- Part 8 : Test Methods and Criteria for Fire Resistance of Elements of Building Construction.

Testing for Classification in class 0 is carried out according to Part 6, while classes 1 to 4 are classified with Part 7.

BS 2782 Test methods for plastics

Where other test methods seem to be unduly stringent for thermoplastics, these tests make them appropriate for their use as e.g. roof lights, ceiling tiles etc.

BS 2782 method 102C stands for determination of the softening point.

Product liability clause: This information and our technical advice - whether verbal, in writing or by way of trials - are given in good faith but without warranty, and this also applies where proprietary rights of third parties are involved. Our advice does not release you from the obligation to verify the information currently provided - especially that contained in our safety data and technical information sheets - and to test products as to their suitability for the intended processes and uses. The application, use and processing of our products and the products manufactured by you on the basis of our technical advice are beyond our control and, therefore, entirely your own responsibility. Our products are sold in accordance with the current version of our General Conditions of Sale and Delivery.

Technical Information, December 2007

Overview of fire tests per country

GREAT BRITAIN

BS 476 : PART 6 Fire Propagation Test

This method is in fact a determination of heat release.

Test Specifications	
Specimen	3 Specimens 228 x 228 x gauge
Specimen position	Vertical
Ignition source	- Two 1000 W elec. elements with variable output : 1800 W after 2 min. 45 sec. ; 1500 W after 5 min. Distance to specimen : 45 mm. - Gas pipe burners with 14 holes ; flame applied 25 mm above the bottom of the exposed face of the specimen ; distance to specimen : 3 mm
Test duration	20 min.
Conclusions	Class 0 achieved if indices $i_1=6$ and $i_2=12$.

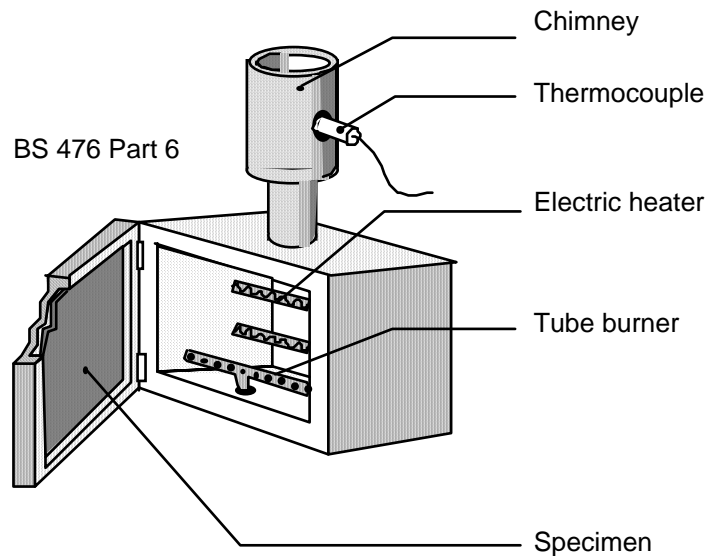

Technical Information, December 2007

Overview of fire tests per country

GREAT BRITAIN

BS 476 : PART 7 Surface Spread of Flame

Test specifications	
Specimen	6 specimens 900 x 230 mm x original thickness
Specimen position	Vertical ; longitudinal axis per pending to radiant panel
Ignition source	- Gas fired radiant panel, intensity from 75 mm = 37 kW/m ² - Gas pilot flame 75 mm height, below the specimen
Test duration	10 min.
Conclusions	Classification class 1 to 4 depending on test performance

The classification depends on the length of flame spread after certain periods of time.
Class 1 is best.

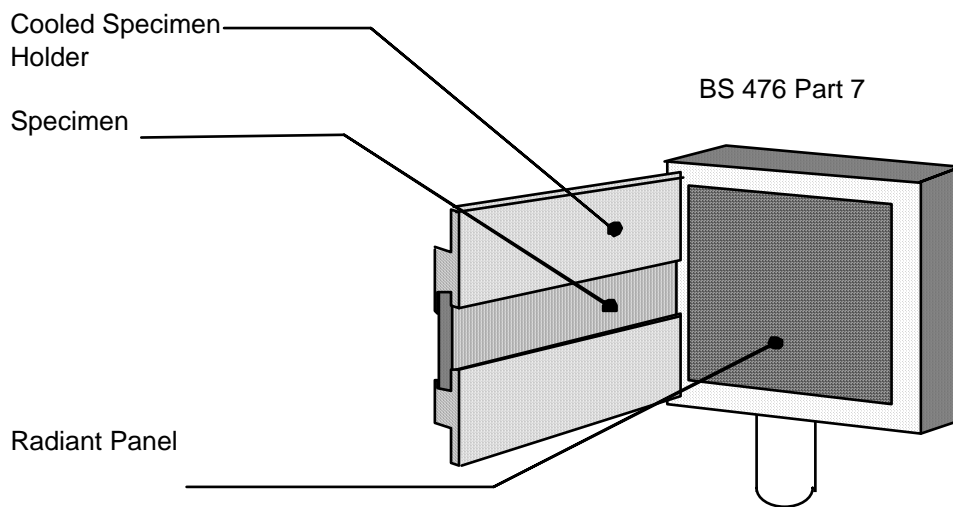

Product liability clause: This information and our technical advise - whether verbal, in writing or by way of trials - are given in good faith but without warranty, and this also applies where proprietary rights of third parties are involved. Our advice does not release you from the obligation to verify the information currently provided - especially that contained in our safety data and technical information sheets - and to test products as to their suitability for the intended processes and uses. The application, use and processing of our products and the products manufactured by you on the basis of our technical advice are beyond our control and, therefore, entirely your own responsibility. Our products are sold in accordance with the current version of our General Conditions of Sale and Delivery.

Technical Information, December 2007

Overview of fire tests per country

FRANCE

French building regulations for the public building sector differ from those for the private sector. This explains why the French fire regulations relate mainly to high rise buildings and buildings open to the public. The regulations are contained in brochures entitled "*Sécurité contre l'Incendie*".

The classification of the fire performance of building materials is now expressed in following symbols:

M0	non-combustible	(incombustible)
M1	non-flammable	(non inflammable)
M2	low flammability	(difficilement inflammable)
M3	moderate flammable	(moyenne inflammable)
M4	high flammability	(facilement inflammable)

All materials from Bayer Sheet Europe are considered as rigid materials

All materials are primarily tested whether they can be classified M0 to M3. Complementary tests are carried out for the M4 classification, or to confirm the classification in M1 to M3.

For the assessment, the NF P 92-501 Epiradiateur test and the NF P 92-505 Dripping test are used, as described on the next pages.

Technical Information, December 2007

Overview of fire tests per country

FRANCE

NF P 92-501 Epiradiateur test

During this test also secondary effects, like smoke generation, burning droplets, glowing,... are recorded.

Test specifications NF P 92-501	
Specimen	4 specimens 300 mm x 400 mm x gauge
Specimen position	inclined at 45°
Ignition source	- Electric radiator (inclined at 45°) of 500 W; 30 mm from specimen: 3W/cm ² - 2 Butane pilot flames for igniting the combustible decomposition gases.
Test duration	20 min.
Conclusions	Classification according to flammability in classes: M1 :::: specimen burns = 5 sec, no droplets M2 :::: specimen burns > 5 sec, damaged length < 350 mm, no droplets M3 :::: specimen burns > 5 sec, damaged length < 600 mm, no droplets >M3 :: specimen burns > 5 sec, damaged length > 600 mm or droplets

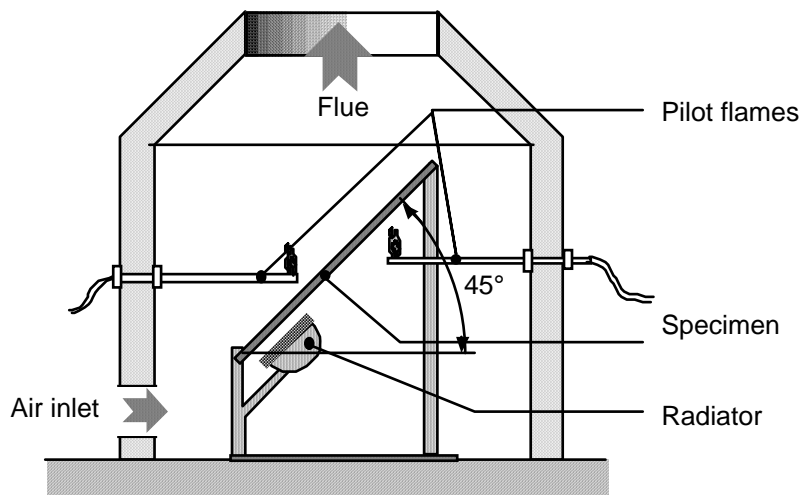

NF P 92-501 Epiradiateur test

Product liability clause: This information and our technical advice - whether verbal, in writing or by way of trials - are given in good faith but without warranty, and this also applies where proprietary rights of third parties are involved. Our advice does not release you from the obligation to verify the information currently provided - especially that contained in our safety data and technical information sheets - and to test products as to their suitability for the intended processes and uses. The application, use and processing of our products and the products manufactured by you on the basis of our technical advice are beyond our control and, therefore, entirely your own responsibility. Our products are sold in accordance with the current version of our General Conditions of Sale and Delivery.

Technical Information, December 2007

Overview of fire tests per country

FRANCE

NF P 92-505 Dripping test

The dripping test (*Essai de goutte*) is a further complementary test to determine burning drops. It is only carried out if during the relevant primary test (NF P 92-501) non-burning drops are observed, or if the material withdraws very rapidly or without burning.

Test specifications NF P 92-505	
Specimen	4 specimens 70 mm x 70 mm
Specimen position	Horizontal on wire gauze.
Ignition source	Horizontal 500 W electric radiator; intensity (30 mm from specimen) 3 W/cm ² .
Test duration	10 min.
Conclusions	If cotton wool ignites, material is classified as class M4

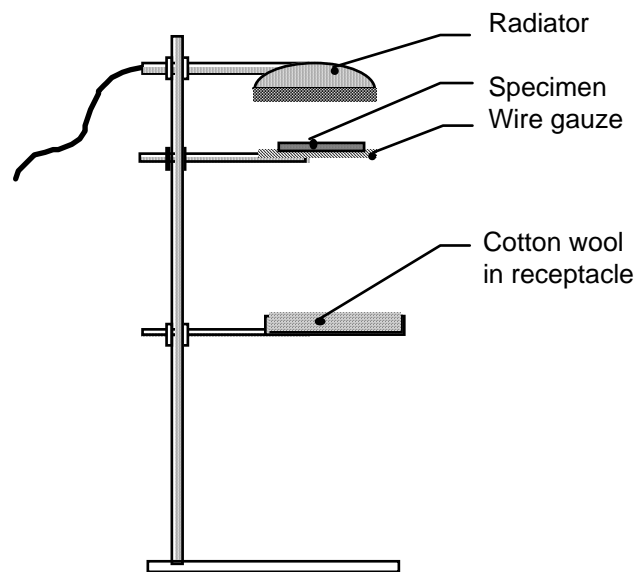

NF P 92-505 Dripping Test

Technical Information, December 2007

Overview of fire tests per country

UNITED STATES

UL 94 Flammability tests

In the US, the safety of electrical equipment and installations is governed by the regulations and approval procedures of the Underwriters' Laboratories Inc. (UL).

UL 94 is one of the most important standards in fire tests for plastics. It applies to electric industry and other areas of application except the use of plastics in building.

UL 94 contains tests for horizontally and vertically positioned specimens.

UL 94 HB

Test specifications	
Specimen	3 Specimens 127 mm x 12,7 mm x gauge. If gauge < 3,2 mm; 3,2 mm to be tested in addition. Reference marks 25,4 and 102 mm from free end.
Specimen position	Longitudinal axis if sample horizontal. Transverse axis at 45° to horizontal.
Ignition source	Bunsen burner with 25 mm flame.
Test duration	30 sec or until first mark is reached.
Conclusions	Class UL 94 HB if <ol style="list-style-type: none"> burning rate = 38 mm/min (gauge= 3 mm). burning rate = 76mm/min (gauge< 3 mm). Samples extinguish before upper mark is reached.

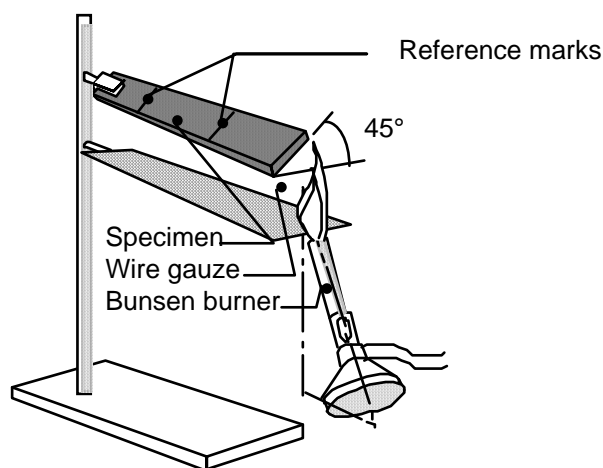

UL 94 HB

Product liability clause: This information and our technical advice - whether verbal, in writing or by way of trials - are given in good faith but without warranty, and this also applies where proprietary rights of third parties are involved. Our advice does not release you from the obligation to verify the information currently provided - especially that contained in our safety data and technical information sheets - and to test products as to their suitability for the intended processes and uses. The application, use and processing of our products and the products manufactured by you on the basis of our technical advice are beyond our control and, therefore, entirely your own responsibility. Our products are sold in accordance with the current version of our General Conditions of Sale and Delivery.

Technical Information, December 2007

Overview of fire tests per country

UNITED STATES

UL 94 V

The UL 94 V classifications (V-0, V-1 and V-2) are more rigorous than UL 94 HB due to the vertical position of the specimen preheating the material above the flame.

Test specifications	
Specimen	2 sets of 5 specimens 127 mm x 12,7 mm x gauge One set stored 23°C/50 R.H., other set dry at 70°C
Specimen position	Longitudinal axis vertical. Horizontal layer of surgical cotton 6mm is placed 305 mm below free edge.
Ignition source	Bunsen burner with 19 mm flame.
Test duration	10 sec per specimen. When extinguished another 10 sec.
Conclusions	Class UL 94 V-0 if: <ol style="list-style-type: none"> 1. Afterflame < 10 sec, sum 10 applications = 50 sec 2. No burning drops. 3. Specimens do not burn up completely. Class UL 94 V-1 if: <ol style="list-style-type: none"> 1. Afterflame < 30 sec, sum 10 applications = 250 sec 2. and 3. as for UL 94 V-0 Class UL 94 V-2 if: <ol style="list-style-type: none"> 2. Ignition of the cotton by burning drops 1. and 3. as for UL 94 V-1

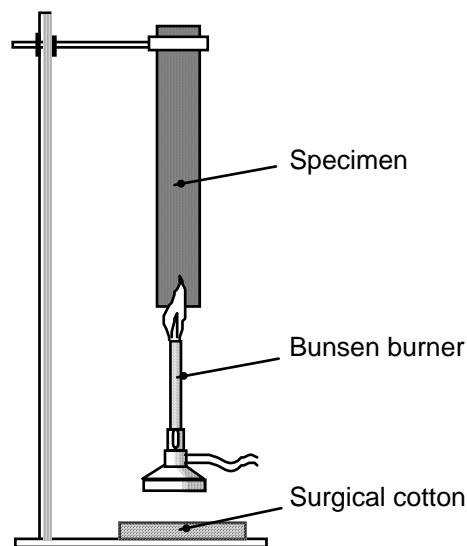

UL 94 V

Technical Information, December 2007

Overview of fire tests per country

UNITED STATES

UL test 5V, 5VA, 5VB

Test specifications	
Specimen	Bars: 127 x 12,7 mm (thickness as specified on yellow card) Plaques: 152 x 152 mm (idem)
Pretreatment	On two sets of samples <ol style="list-style-type: none"> 1. 5 bars or 3 plaques conditioned for 48 hours at 23° C, 50% R. H. 2. 5 bars or 3 plaques conditioned for 168 hours at 70° C
Burner	Bunsen 9,5 diameter, 100 mm length
Flame height	127 mm (inner blue core 38 mm)
Gas	Technical grade methane or earth gas having a heat capacity of 37 MJ/m ³
Samples positioning	Bars: vertical Plaques: horizontal
Contact time	5 x 5 seconds with intervals of 5 seconds (bars and plaques)
Apparatus	See Figure 1 below

5V classification

1. No flaming or glowing- 60 s after the last flame application.
2. No dripping at all.
3. No significant destruction of the sample in the flame area.

5VA classification (bars and plaques)

1. No flaming or glowing- 60 s after the last flame application.
2. No ignition of the cotton by dripping particles.
3. No holes in the plaques.

5VB classification (bars and plaques)

1. No flaming or glowing- 60 s after the last flame application.
2. No ignition of the cotton by dripping particles.
3. A hole in the plaque is acceptable.

For all above mentioned classifications, a one time retesting of a set of test specimens is allowed if only 1 test bar fails.

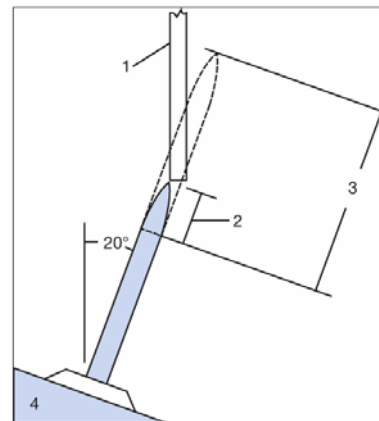

Fig. 1: Vertical burning test for UL94-5V classification

- | | |
|---|-------------------------|
| 1 | Specimen |
| 2 | Inner blue cone |
| 3 | Overall height of flame |
| 4 | Mounting block |

Product liability clause: This information and our technical advice - whether verbal, in writing or by way of trials - are given in good faith but without warranty, and this also applies where proprietary rights of third parties are involved. Our advice does not release you from the obligation to verify the information currently provided - especially that contained in our safety data and technical information sheets - and to test products as to their suitability for the intended processes and uses. The application, use and processing of our products and the products manufactured by you on the basis of our technical advice are beyond our control and, therefore, entirely your own responsibility. Our products are sold in accordance with the current version of our General Conditions of Sale and Delivery.

Technical Information, December 2007

Overview of fire tests per country

ALL COUNTRIES

Glow wire test / IEC 60695-2-1/0, 1, 2, 3

- Glow Wire Test applicable to devices or sub-assemblies or parts of it
- Glow Wire Flammability Index "GWFI" measured on material plates
- Glow Wire Ignition Temperature "GWIT" measured on material plates

Scope:

1. Glow Wire Test

Components or parts may, under faulty or overload conditions, reach a temperature such they are unduly affected or such that they will ignite parts in their vicinity. The glow wire test simulates thermal stresses which may produced by such sources of heat or ignition, for example glowing elements or overloaded resistors, for short periods, in order to simulate the fire hazard. It is applied to devices or parts of them.

2. Glow Wire Flammability Index: "GWFI"

The "GWFI" of a material is determined by applying the glow wire test of material plates under similar conditions that apply to the actual devices or parts of it. This permits a comparison to be made of the materials in terms of their extinguishing capabilities.

3. Glow Wire Ignition Temperature "GWIT"

The "GWIT" of a material is determined by applying the glow wire test to material plates under similar conditions to apply to the actual devices or parts of it. This permits a comparison to be made of the materials in terms of their relative resistance to ignition.

Test specifications			
	Glow wire test	GWFI	GWIT
Sample	Complete equipment sub-assembly or part of it	Plates 60 x 60 x e mm	Plates 60 x 60 x e mm (e = thickness)
Conditioning	24 hours 15° C <= temperature <=35° C 45% <=RH<=75%	48 hours at 23°C 50% RH	
Glow wire	See Figure 2 below		
Glow wire temperature	550, 650, 750, 850, 960	500, 550, 600, 650, 700, 750, 800, 850, 900, 960	
Force	0,8 to 1,2 N 2 N (HE60E01)	0,8 to 1,2 N	0,8 to 1,2 N
Time of contact	30 s	30 s	30 s
No. of contacts	1	3 successive	3 successive
Apparatus	See Figure 3	See Figure 3	See Figure 3

Technical Information, December 2007

Overview of fire tests per country

Significance

GWIT: is defined as the maximum glow wire temperature, at which there is no ignition of the plate, for 3 successive applications, and to which one adds 25 K. That is, $GWIT = \text{Maximum temperature without ignition} + 25 \text{ K}$. For example: A product passes the GWIT at 825°C with a 3 mm thickness will be rated GWIT 850/3.

GWFI: The GWFI is the highest temperature of the glow wire, applied three successive times to plate and on each occasion the plate extinguishes in a maximum of 30 seconds after the glow wire withdrawal, and it does not ignite the wrapping tissue under the test plate.

VDE 0471m part 2-1	CEE (031-SEC) F 142 E
DIN IEC 695-2-1	BS 1313 § 23
IEC 60695-2-1	HE 60-E-01 (EDF)
NF C 20-455	AS 2420
BS 5733 § 32.4	

Device Glow Wire Test

Unless otherwise specified by the standard for the device, the specimen is considered to have withstood the Glow Wire Test at a given temperature if either:

- there is no flame or glowing of the specimen
- the specimen flames and the layer below flames extinguish in a maximum of 30 seconds after removal of the glow wire. The layer below should not be totally burned. If the layer below is wrapping tissue, it should not ignite.

Many standards refer to the Glow Wire Test and differences may exist compared to the IEC test method.

- Some specifications specify a maximum flame height of 30 mm to pass the test.
- The HN60-E-01 specifies an extinction time of maximum 5 seconds.

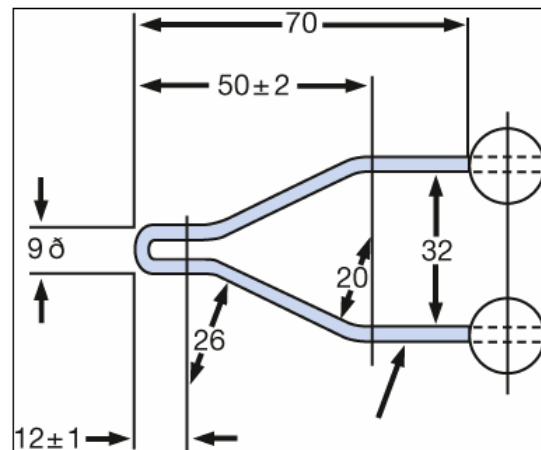

Fig. 2: Glow-wire

Product liability clause: This information and our technical advice - whether verbal, in writing or by way of trials - are given in good faith but without warranty, and this also applies where proprietary rights of third parties are involved. Our advice does not release you from the obligation to verify the information currently provided - especially that contained in our safety data and technical information sheets - and to test products as to their suitability for the intended processes and uses. The application, use and processing of our products and the products manufactured by you on the basis of our technical advice are beyond our control and, therefore, entirely your own responsibility. Our products are sold in accordance with the current version of our General Conditions of Sale and Delivery.

Technical Information, December 2007

Overview of fire tests per country

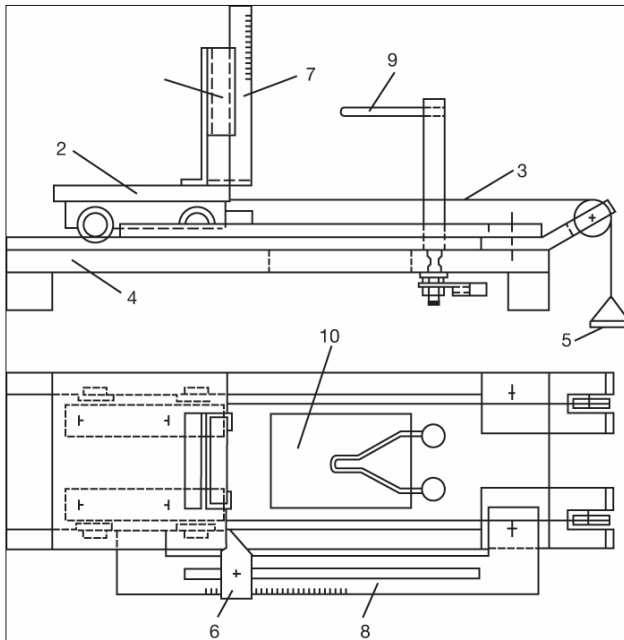

Fig. 3: Test equipment:

- 1 Positioning clamp
- 2 Carriage
- 3 Tensioning cord
- 4 Base plate
- 5 Weight
- 6 Stop
- 7 Scale for measure of flame
- 8 Scale for penetration
- 9 Glow wire (see fig.2)
- 10 Break- through in base plate for particles falling from the specimen

For more information please contact your local representative.