

# SOLID-STATE AUDIO POWER

Valve audio amplifiers generally require an output coupling transformer to match the output impedance to that of the loudspeaker load. If a good performance is sought, this component will be expensive and bulky. The savings in cost and bulk which are possible and the improvement in performance, especially at the extreme ends of the audio spectrum, by avoiding the need for this component have remained one of the major benefits of "solid-state" circuitry.

## Early transistor audio amplifiers

Understandably, early designs in this field owed a lot to previous valve amplifier practice, with transformer inter-stage coupling being used to allow a push-pull output configuration. However, the real break-through in this field came with the introduction, in 1956, of the "quasi-complementary" output stage due to H.C. Lin<sup>1</sup>, of which the basic circuit layout is shown in Fig. 1.

At the time, the most easily obtained transistors were germanium diffused-junction p-n-p devices, although some germanium n-p-n transistors were becoming available in low-power versions. The attractive feature of Lin's design was that the circuit provided a push-pull output without the need for a coupling transformer, and with a pair of output transistors which were both of the same type. In addition, it only required one low-power n-p-n device.

The performance of this circuit was excellent by contemporary transistor audio-amplifier standards, in that it had a 30Hz – 15kHz bandwidth and a full-output-power THD figure of less than 1% at 1kHz, which decreased somewhat with decreasing output power. However, germanium transistors have too high a temperature coefficient of leakage current for them to be suitable for domestic use, where thermal runaway could never be completely ruled out.

Sadly, the relative excellence of the



John Linsley Hood traces the evolution of transistor audio power amplifiers from 1956 to the present day. Designs produced up to 1975, covered in this first part, reached a high standard, but still contained residual design mistakes

Lin circuit, which was designed around germanium transistors, gave misleading encouragement to other engineers, on a world-wide basis, who translated the design into silicon-transistor-based versions when, during the early 1960s, n-p-n silicon planar power transistors became available.

The inherent snag in this approach is that the base voltage/collector current characteristics of germanium and silicon transistors are different, with that of the silicon device being much more abrupt, as shown in Fig. 2.

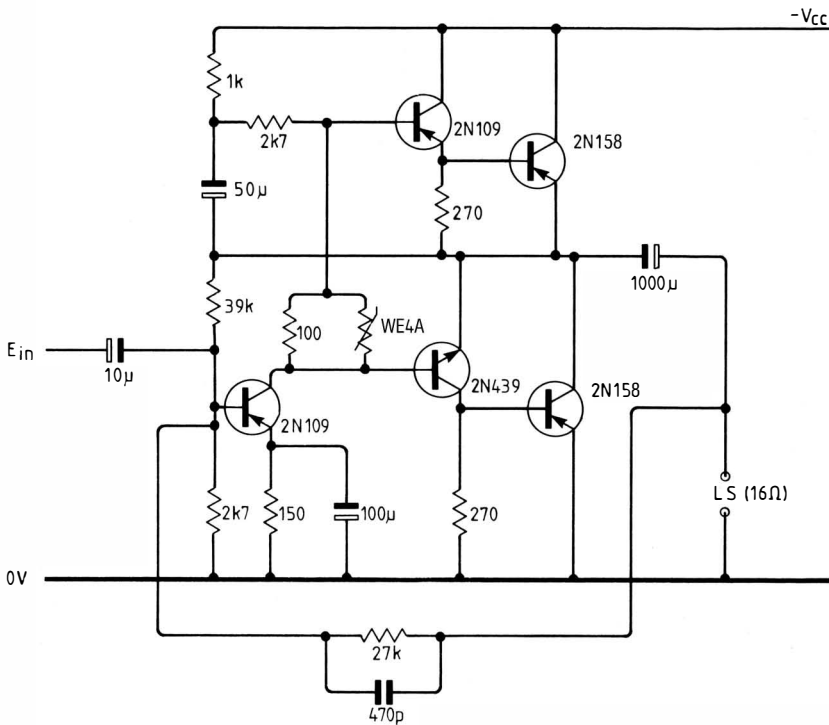
Moreover, since the permissible thermal dissipations of the output devices were then fairly limited – by comparison with valves – it was necessary to operate the output stages at a fairly low quiescent current, in class AB, or even (with zero quiescent current) in class B. High (notional) levels of negative feedback were then used to lessen the residual distortion which this incurred.

This design philosophy had the unfortunate effect of maximizing the performance penalties, in that the high levels of NFB inevitably contributed to poor overall loop-stability margins while, at the "crossover" point, the effective gain of the output devices was low or even zero, so that the NFB was ineffective in reducing the distortion at the very point where it would have been useful.

Also, because of the basic asymmetry of the "quasi-complementary" output stage, as shown in Fig. 3, not only was the residual inherent distortion large, but it tended to increase as the output power level was reduced, as shown in Fig. 4.

This meant that a manufacturer's specification which claimed, for example, "better than 0.05% THD at full output power" might be quite irrelevant to the user, who might have to put up with ten times this amount of distortion at his normal listening levels.

Moreover, the residual distortion, especially at low powers, was rich in dissonant harmonics, which were alien to the normal experience of the human



**Fig. 1. Original quasi-complementary transistor power amplifier by H.C. Lin, from 1956.**

ear. In addition, the reduced gain at the point at which the signal waveform crossed the zero axis tended to suppress low-level signal components and give the amplifier a "thin" sound, lacking in "warmth" and "richness".

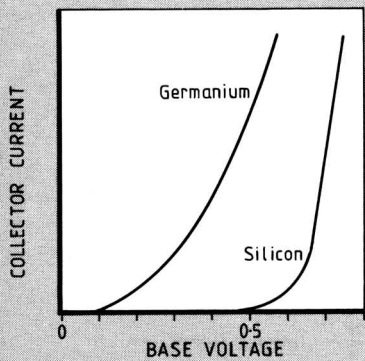
It was hardly surprising, therefore, that these early silicon-transistor quasi-complementary "high-fidelity" designs won few friends among their users. More regrettably in the long term, this unfortunate and temporary lapse of design standards has led to two break-away movements among the 'hi-fi' community: the "all specifications are meaningless, so only believe your ears" fraternity, and the "back to valves" brigade.

## Improved output-stage configurations

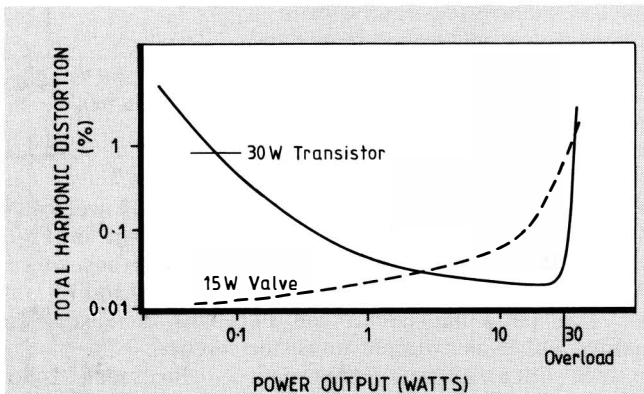
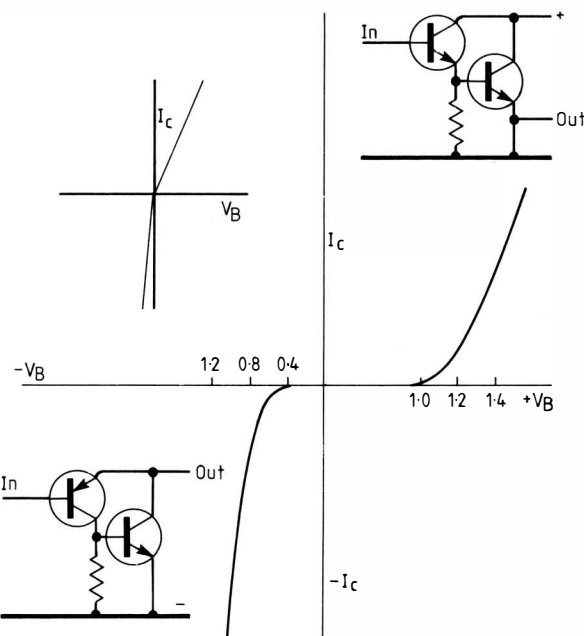
There were, in the 1960s, three practicable options for improving the performance of audio-output stages: to use fully complementary output devices, which were just becoming commercially available; to use the output devices in class A; or to modify the quasi-complementary arrangement so that it gave greater symmetry in the two halves.

The first of these approaches was adopted, soon after suitable devices became available, by Locanthi<sup>2</sup> and Bailey<sup>3</sup>. The output stages of a 30W per channel design due to Bailey are shown in Fig. 5.

There are two difficulties inherent in this approach, of which the first is that the p-n-p output devices were, at that time – and to some extent even today –

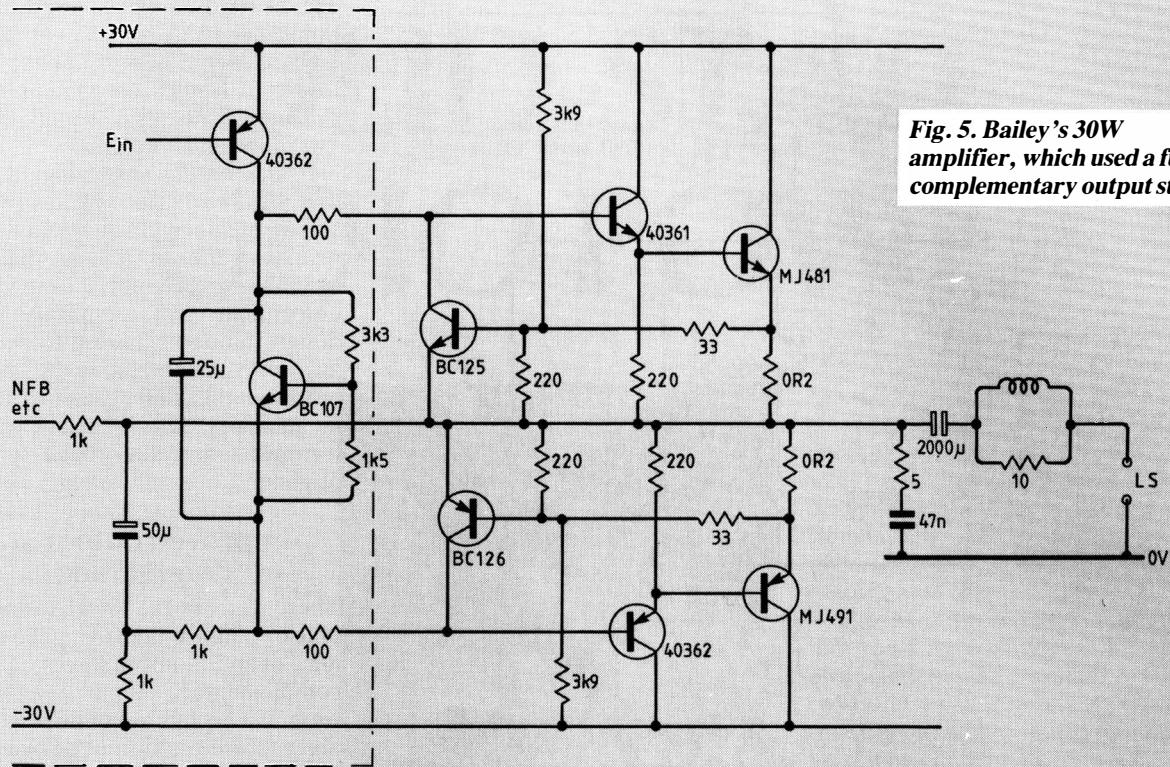


**Fig. 2. Comparison of silicon and germanium base-voltage/collector-current curves at 25°C.**



**Fig. 3. Asymmetry of silicon quasi-complementary pair. Small diagram shows crossover characteristic when pair optimally biased.**

**Fig. 4. Asymmetry of early silicon quasi-complementary amplifiers shown in Fig. 3 gave rise to increasing crossover distortion at low power levels, in contrast with the behaviour of a good-quality valve amplifier.**



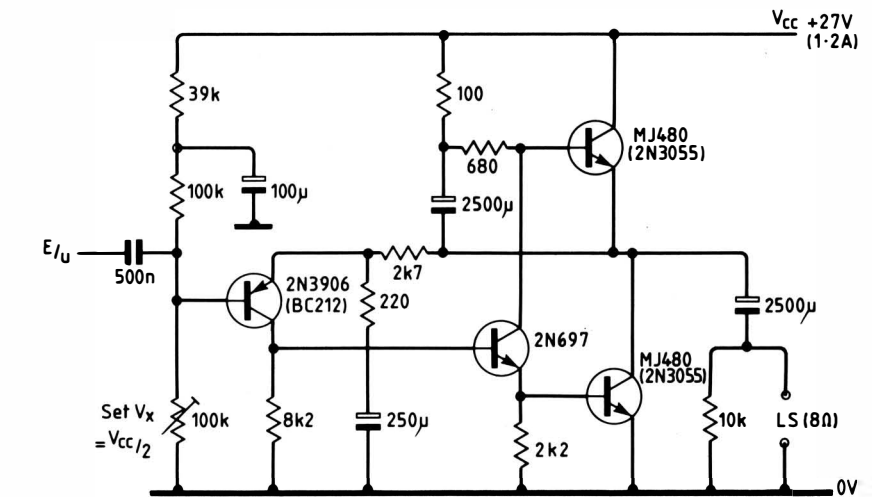
**Fig. 5. Bailey's 30W amplifier, which used a fully complementary output stage.**

rather more fragile than their nominal n-p-n equivalents, which prompted Bailey to evolve an effective overload protection circuit, also shown in the diagram.

The second problem is that, because of the different majority carriers in the two transistor forms, p-n-p devices tend to have a lower HF transition frequency than equivalent n-p-n ones. The difference in the transition frequencies of the "complementary" output transistors leads to asymmetry of the output stage at higher audio frequencies, with a consequent worsening of crossover and other distortion characteristics.

At that time my own preference, provided that the power requirement was relatively modest, was for the use of class A operation, and a circuit for a 10W power amplifier using this philosophy<sup>4</sup> is shown in Fig. 6. This is not a push-pull system, and is therefore intrinsically free from crossover problems. This particular circuit can be visualized either as a simple transistor gain stage with an active collector load, or as an emitter follower with an active emitter load. A difficulty in the use of this layout is that it has a low overall efficiency and is not easily extended in power without the use of a bridge configuration.

The third approach is exemplified by a neat circuit adaptation due to Shaw<sup>5</sup>, in which an added diode is used to lessen the differences between the up-



**Fig. 6. Author's 1969 10W class A amplifier. Since the operation is not push-pull, there is no crossover distortion.**

per and lower halves of the output pair, as shown in Fig. 7(a). Because the output transistors can then be of identical type (and  $F_t$ ), the worsening of THD with increase in frequency can be lessened.

Baxandall, following an analysis of this problem<sup>6</sup>, suggested an elegant circuit improvement, shown in Fig. 7(b), which almost completely eliminates the dissimilarity between the upper and lower halves of the output stage, and allows a low-distortion design to be made with identical output transistor types.

For a subsequent higher-power amplifier design<sup>7</sup>, I followed in the

footsteps of Shaw and Baxandall, with the circuit layout shown in Fig. 7(c), in which I had added a small capacitor to the resistor/diode network to simulate the effect of the output transistor base/emitter capacitance.

An alternative arrangement, introduced commercially by the Acoustical Manufacturing Co.<sup>8</sup> in their Quad 303 power amplifier, employed a pair of quasi-complementary triplets, of the type shown in Fig. 8. This generates a

**Fig. 7. Shaw's improved quasi-complementary design from 1969, which used a diode to improve symmetry, is seen at (a). At (b), Baxandall's variation further improves symmetry, and (c) shows author's use of small capacitor to simulate effect of base/emitter capacitance.**

high internal loop gain within each of the compound output emitter-follower groups, which helps to minimize the asymmetry of the output stage "halves" and the residual crossover distortion which this asymmetry introduces.

Other layouts have been proposed to improve symmetry in such quasi-complementary pairs, such as that due to Visch<sup>9</sup> and Stevens<sup>10</sup>, but contemporary high-quality design appears to be exclusively committed to symmetrical layout employing complementary transistors, which use either the output transistor configuration shown in Fig. 5, or that of a symmetrical compound emitter follower of the type shown in Fig. 9. This has the advantage that the base/emitter junctions of the output devices, which will get hot, are not included in that part of the circuit which determines their forward bias, which offers better output-stage quiescent current stability.

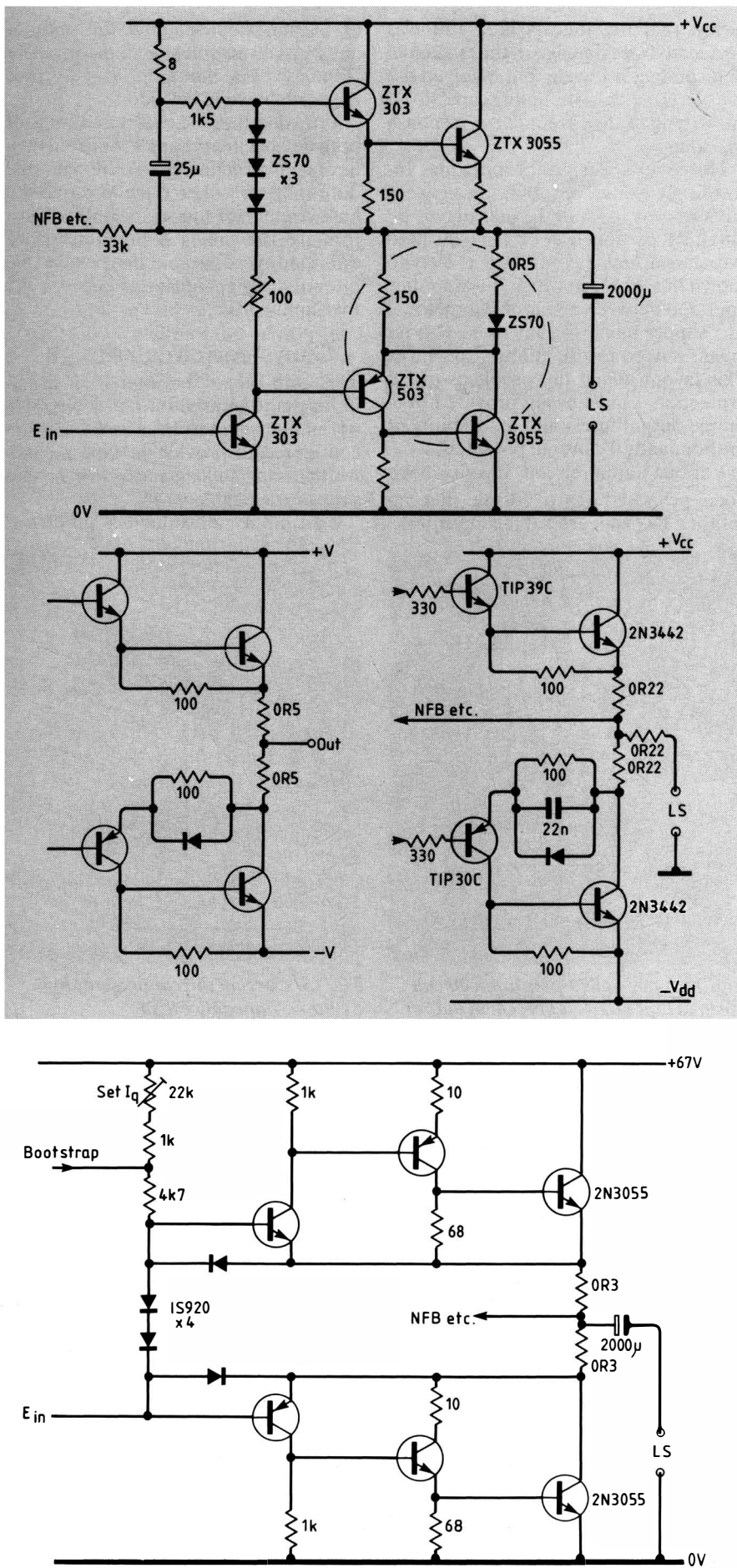
All of these class AB circuit layouts require that the quiescent current in the output stage remains close to some optimum value if the target performance of the design is to be achieved, in spite of changes in the temperature and age of the components. This has been the subject of considerable circuit development, of which some radical approaches are discussed later.

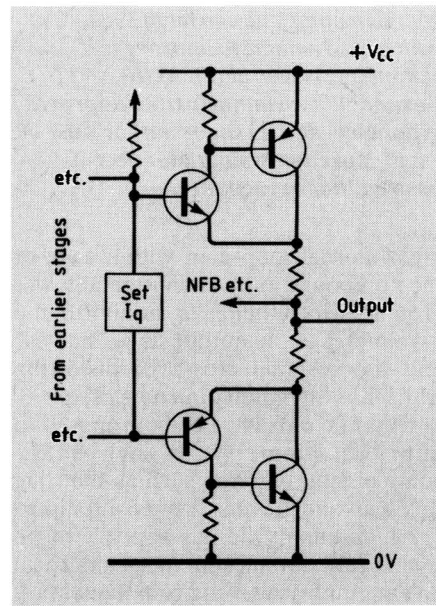
With an eye on their use as output devices, several manufacturers have introduced low-cost, high-specification, monolithic, Darlington-connected output transistors, having the internal structure shown in Fig. 10. However, because the driver transistor is on the same chip as the output device and is heated by it, the use of such output transistors makes output-stage quiescent-current stability more difficult to achieve.

## Direct-coupled layouts

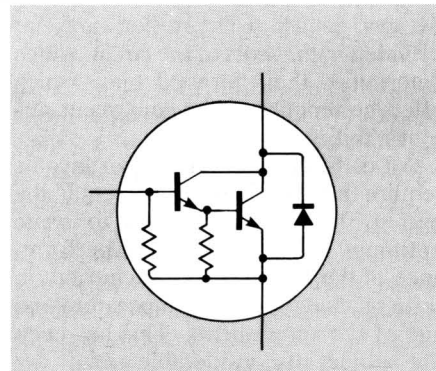
All of the earlier "transformerless" transistor power amplifier layouts were designed to operate between the 0V rail and some single positive (or negative) supply line, with a DC blocking capacitor to the loudspeaker, using a layout similar to that shown in Fig. 6. This

**Fig. 8. Quad 303 quasi-complementary triplets.**

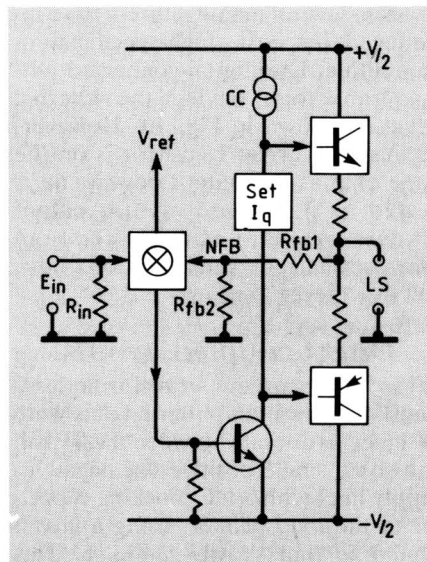




**Fig. 9. Symmetrical compound emitter-follower. Bias is less temperature-dependent.**



**Fig. 10. Internal structure of n-p-n Darlington transistor.**



**Fig. 11. Use of symmetrical supplies avoids need for blocking capacitor.**

meant that the loudspeaker unit was protected from damage in the event of a semiconductor failure, but involved the use of a large-value coupling capacitor if an extended low-frequency response was sought.

However, designers became increasingly convinced that there were advantages in sound quality to be obtained by the use of the so-called direct-coupled layout, of the type shown in Fig. 11, in which the amplifier operated between a pair of symmetrical ( $\pm$ ) supply lines, so that there was no longer a need for the output capacitor. This layout added the problems of LS protection – most easily provided by a simple output fuse – and the stability of the nominally 0V output potential.

Various input circuit layouts have been proposed<sup>3,11</sup> to ensure that no residual DC appeared at the loudspeak-

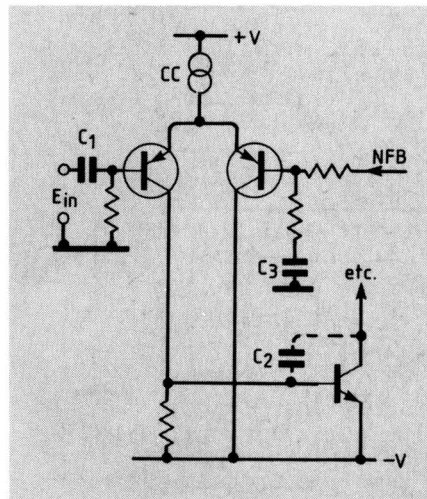
er output terminals, but the simplest and most direct solution to this problem is the use of an input long-tailed pair of the kind shown in Fig. 12.

Provided that the emitter currents of both devices are the same, and that they have similar values of current gain, the output offset will be close to zero if the base circuit resistances for both transistors are the same. A high-impedance tail load is desirable to ensure the integrity of signal transfer between the two input halves.

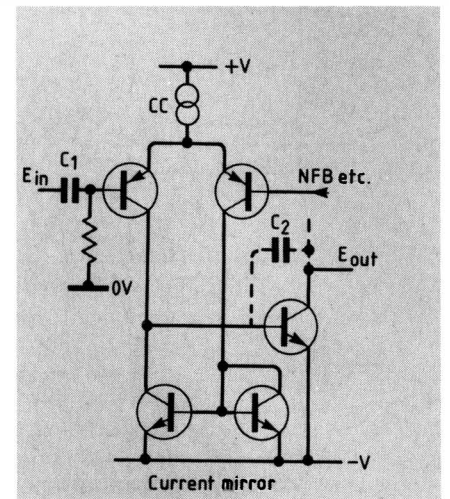
## Gain stage circuit designs

The gain stages between the signal-input point and the output devices are normally operated in class A and are configured to provide as wide a bandwidth, as high a gain and as low a phase shift as practicable.

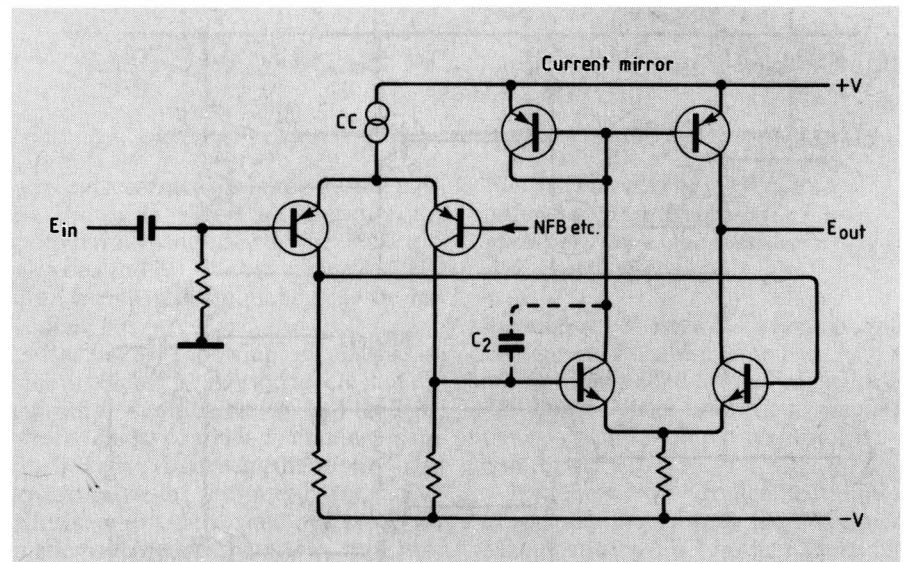
To simplify loop-stability problems,



**Fig. 12. Long-tailed-pair input circuit ensures that no DC is present at output.**



**Fig. 13. Current mirror presents high dynamic-impedance load.**



**Fig. 14. Current-mirror shifted to second stage, as used in ICs by National Semiconductor and by Hitachi in an audio power amplifier.**

the gain block is normally restricted to two stages and, to get as high a gain as possible, the collector load for the second stage has as high a dynamic impedance as practicable. This is often a "bootstrapped" load resistor, as employed in the designs of Figs 5 and 6. However, in more recent circuits, a constant-current source load is normally used, since this gives rather better distortion characteristics, especially at LF, though the possible total output voltage swing may be rather less.

The load for this input stage may just be a single resistor, in the first collector circuit, as shown in Fig. 12 although, following the practice in IC op-amps, it is more common to use a current mirror in this position, as shown in Fig. 13.

An interesting development of this idea is to move the current mirror to the position of load for the second gain stage, as shown schematically in Fig. 14. This is an idea which appears to be due to National Semiconductor and is employed in several of its IC op-amp designs, such as the LH0061. This has been adapted, more recently, to an amplifier circuit by Hitachi.<sup>12</sup>

### Loop stability and transient intermodulation distortion

If negative feedback is applied around a circuit enclosing a two-stage gain block as well as an output emitter-follower system, it is probable that the total phase shift within the loop will be 180° at some frequency at which the gain is unity, and the amplifier will oscillate.

It is essential, therefore, to ensure stability by causing the open-loop gain to fall as the frequency approaches the upper (or lower) 180° phase-shift points. With most direct-coupled circuits, the LF loop phase shift will not exceed a safe value; stability problems are therefore confined to the HF end of the pass-band.

It was, and is, customary to achieve HF loop stabilization by imposing a single-pole dominant-lag characteristic on the system by connecting a small capacitor between base and collector of the second gain stage ( $C_2$  in Figs. 12, 13 and 14), since this arrangement gives the best THD performance at high frequencies. However, this approach leads to the problem that it imposes a finite speed of response on the second gain stage while  $C_2$  charges or discharges through its associated base and collector circuits.

If a composite signal including a step waveform is then applied to the input device, it is possible for the input stage to be driven into overload because no

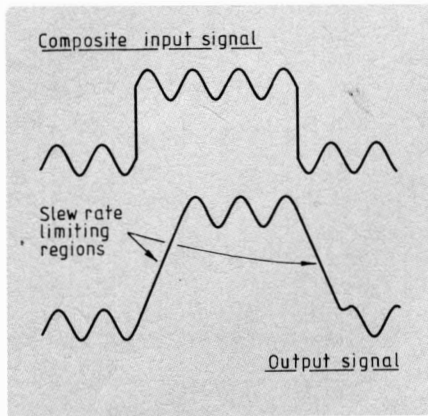


Fig. 15. Effect of slew-rate limiting.

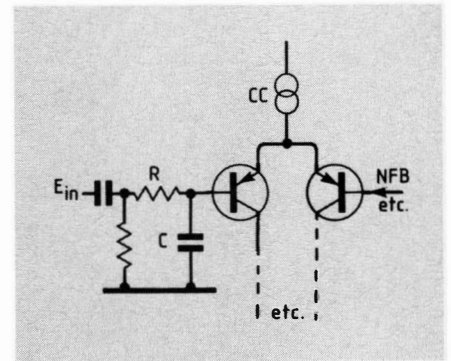


Fig. 16. Input RC filter restricts rate of input voltage change to that of rest of circuitry.

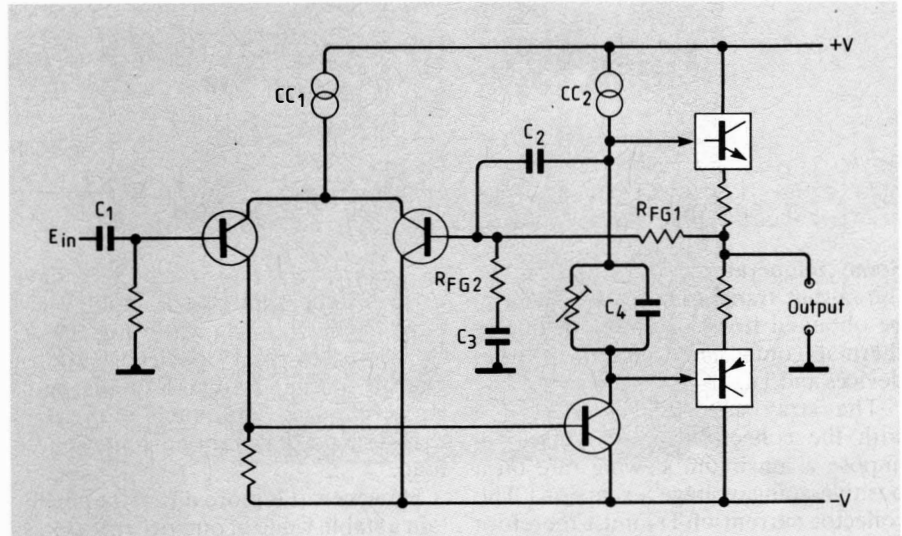


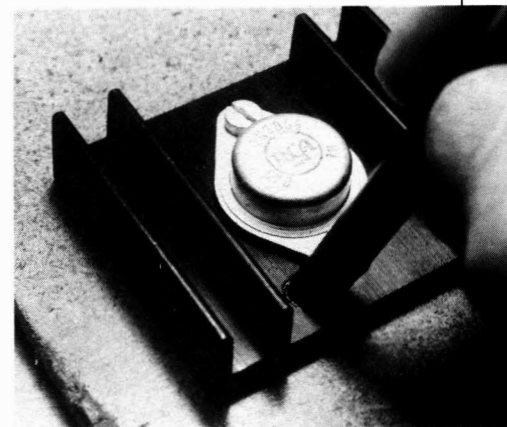
Fig. 17. Preferred position for HF loop compensation capacitor.

compensating feedback signal has yet had time to arrive from the subsequent amplifying stages. This can lead to a complete loss of signal during the period in which the second gain stage is paralysed, and caused Otala<sup>13</sup> to apply the term "transient intermodulation distortion" to the perceived acoustic effect.

A simpler description suggested by Jung<sup>14</sup> is "slewing-induced distortion" (or slew-rate limiting) and this defect in the amplifier performance is clearly visible on an oscilloscope display, with an appropriate composite input signal, as shown in Fig. 15.

This defect is, however, not an inevitable consequence of dominant-lag compensation, since there are ways of avoiding it<sup>15</sup>. Of these the simplest is just to introduce an RC low-pass network at the beginning of the amplifier to restrict the rate of change of input signal voltage, as shown in Fig. 16.

A better alternative is to include the whole of the gain stages within the bandwidth-limiting system, as used, for



example, by Bailey<sup>5</sup> and as illustrated in Fig. 17. Placing  $C_2$  in this position avoids the possibility of input-device overload as a consequence of the sluggishness of response of later stages.

### Other snags

A typical amplifier might, therefore, have the kind of circuit shown in Fig. 18 (resistors  $R_a$  and  $R_b$ , avoid "latch-up").



In the first part of this article, I covered some of the developments in the design of transistor audio power amplifiers from the commercial introduction of transistors to about 1975, by which date some competently engineered designs had been produced.

A fair proportion of the designs produced at the end of this period were capable of a performance which would, to the ear of an unprejudiced listener, at least equal most of the previous generation of valve operated equipments and were also more compact, cooler running and of substantially greater potential output power.

However, design mistakes had been made and some units having a relatively poor acoustic performance had been produced, particularly during the earlier years of this period. Although there was a better understanding of the requirements for audio power amplifiers, some relatively indifferent designs were still being offered. Even in the case of the good designs, some residual intrinsic problems remained.

There was the need to ensure that the quiescent current of the output transistors, in the typical class AB output mode, was correctly set on manufacture and remained correct during the life of the equipment. There was also the problem of time lag in the thermal compensation circuitry, which could mean that the quiescent current setting could be in error at the onset of a burst of high output power or in the period immediately following it.

In addition, the relatively high amounts of negative feedback normally employed in these designs could cause sporadic malfunction when used with loudspeakers which had awkward impedance characteristics, making the amplifiers prone to "hard" clipping on signal overload. This effect would effectively require a larger transistor amplifier to deliver the same amount of apparently undistorted output power to the speaker than would have been the case with a valve design.

### Design trends

At this time, three separate design trends began to emerge, of which the most explicable, from the engineering point of view, was that of removing or

# SOLID-STATE AUDIO POWER

John Linsley Hood  
continues his  
examination of the  
evolution of transistor  
audio power  
amplifiers with a look  
at methods of  
reducing  
residual defects

lessening the residual effects of transistor designs, such as the non-linearity of the class AB push-pull output stage; the variability of, or the need to pre-set some chosen value for, the output stage quiescent current; and, in earlier designs, the need to use high levels of negative feedback to achieve acceptably low levels of harmonic distortion.

The second line of development, pursued with great vigour in Japan, was that of seeking needlessly high levels of steady/state linearity and, in the USA, equally unnecessary – in normal domestic use – levels of output power and bandwidth.

This technical development was mainly spurred on by the belief of the 'man in the street' that he needed high output powers and that large bandwidths and very low THD levels were synonymous with perceived sound quality. The same reasoning would lead to the argument that it was the difference in engine capacity which made a 220BHP Mercedes a quieter and more comfortable car than a Citroën 2CV.

Few lay enthusiasts would accept that they could not hear any difference between two units whose only dissimilarity was that between 0.005% THD and 0.05% THD at any point within the audio pass-band; or that, in the majority of cases, their needs could probably be comfortably met by 5W of peak audio output power.

The third design trend was a wholehearted, and perhaps cynical adoption of pseudo-scientific ideas offered by





eccentric innovators on the fringes of the 'audiophile' fraternity, particularly when these ideas were applauded by the quasi-technical 'hi-fi' press. The hope was, one supposes, that equipment designed in accordance with these ideas might be applauded by the pundits and so become the acoustic criterion by which all other equipment would be judged.

As an engineer, I am more in sympathy with the first of these design trends because their targets are clear and their aims are explicable.

### Circuit developments

**Blomley.** One of the first serious attempts to overcome the difficulties of defining and maintaining the correct quiescent current setting for the output transistors was that due to Blomley<sup>1</sup>, who proposed that crossover distortion should be avoided by arranging that the output transistors were biased permanently to a point at the beginning of the linear part of their  $V_b/I_c$  characteristics. The preceding part of the circuit, of which the whole is shown in schematic form in Fig. 1, is then designed to present the output stage with an input signal divided into two halves by means of a preceding switching stage, so that the output devices are only required to provide an output current which increases from the pre-set quiescent level.

This is effectively a class B driver stage, but the small-signal switching stage can do this job much more accurately and cleanly than the power output devices could ever do and the small-signal switching stage is unlikely to suffer from thermal drift as a result of the total power output of the amplifier.

Although the idea is sensible and practical, no commercial unit based on this system has been offered.

**Error feedforward.** This method of reducing system distortion was envisaged by Black<sup>2</sup>, the inventor of the negative-feedback technique, though at the time of its invention adequate components were not available and it was neglected.

The method was resurrected by Sandman<sup>3</sup> in an interesting contribution in which he showed two practical examples of amplifiers in which distortion was reduced by feeding forward an error signal to the loudspeaker; these

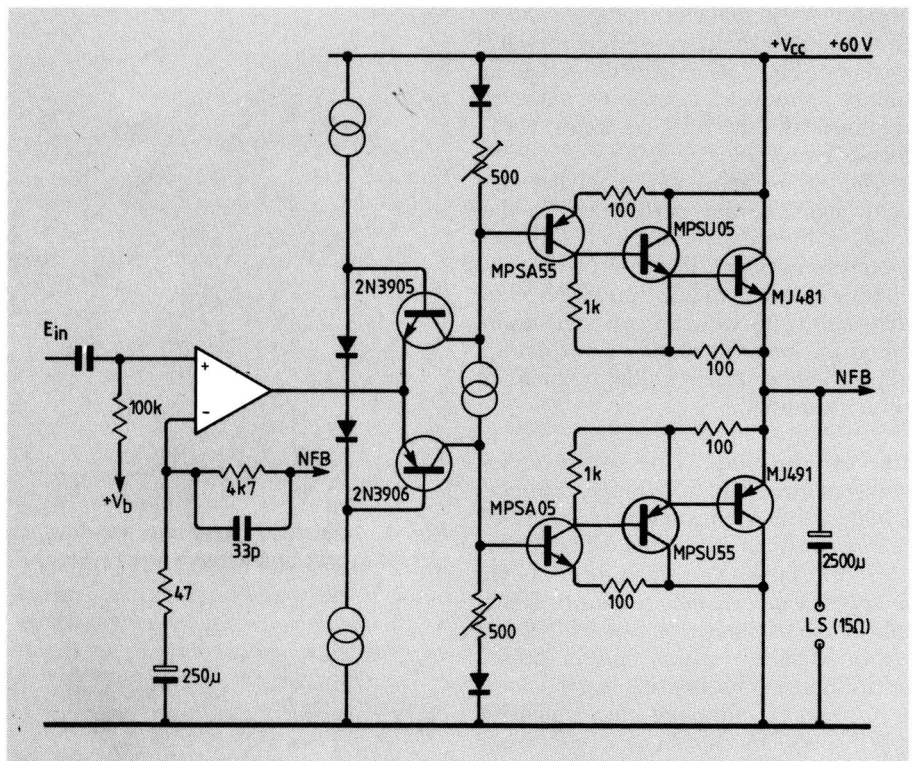


Fig. 1. Simplified Blomley 30W amplifier, with a small-signal switching stage doing the job of a class B output stage.

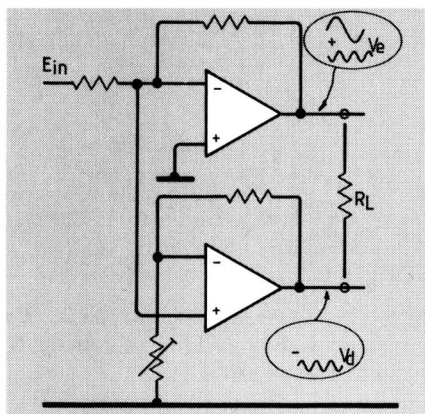


Fig. 2. Distortion correction by error take-off, due to Sandman.

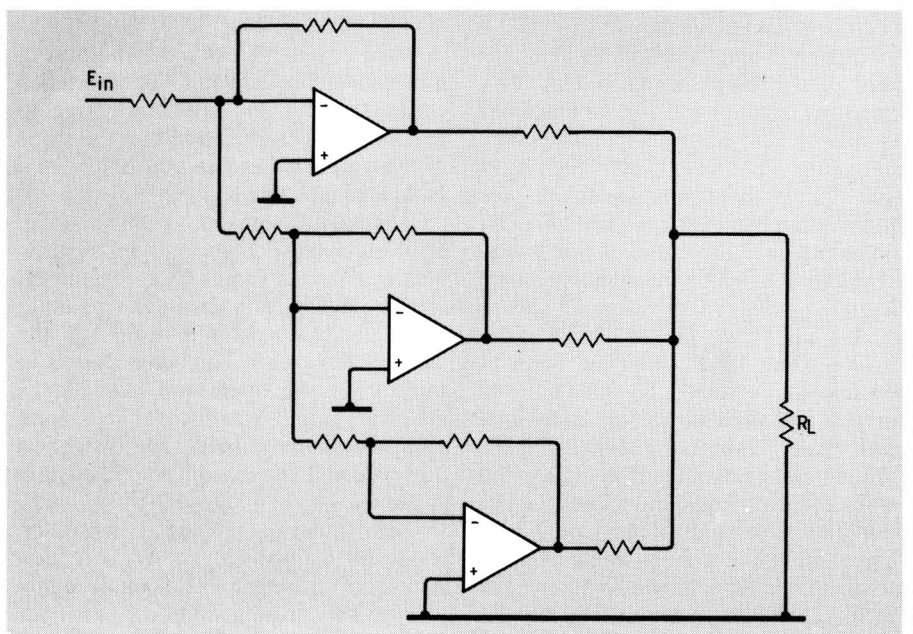


Fig. 3. Iterative feed-forward is theoretically able to reduce distortion as much as required by the use of more feed-forward stages.

are shown schematically in Figs. 2 and 3. In the case of the iterative feedforward system of Fig. 3, the distortion could in theory be reduced to as low a value as required by the use of extra feedforward stages.

The other approach, applying the error signal to the 'earthy' end of the load, is theoretically capable of completely removing all signal errors, including all forms of noise and waveform distortion introduced by the main amplifier, but will require some set-up adjustment as well as a floating speaker return terminal.

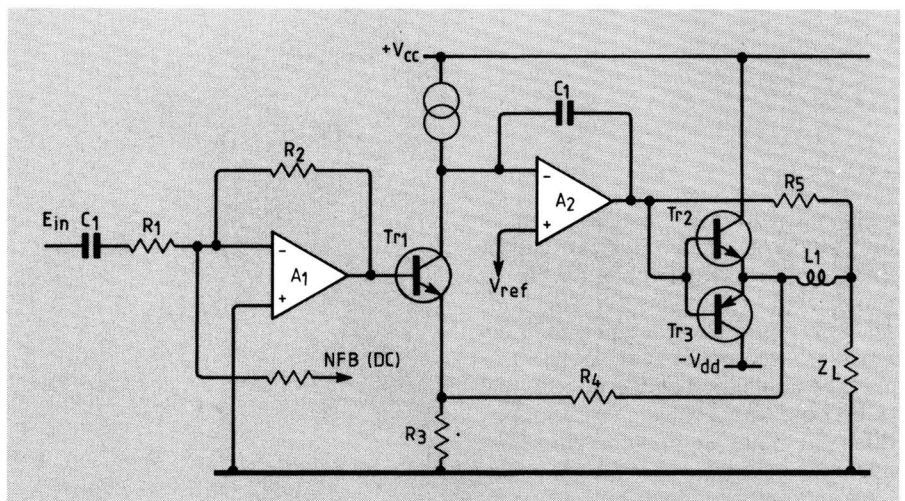
**Current dumping.** This rather inelegantly named circuit arrangement, introduced by Albinson and Walker<sup>4</sup> of the Acoustical Manufacturing Company and shown in outline form in Fig. 4, appears superficially similar to Sandman's feed-forward circuit of Fig. 2, except that it requires neither preset adjustments nor a floating 'earthy' load return point, although this similarity was disputed in a subsequent letter from Sandman<sup>5</sup>.

Of all the circuit designs so far offered, this one seemed to come closest to the ideal transistor layout in that the power transistors could operate without any forward bias whatever and yet allow the low-distortion, low-power amplifier to fill in the residual discontinuities.

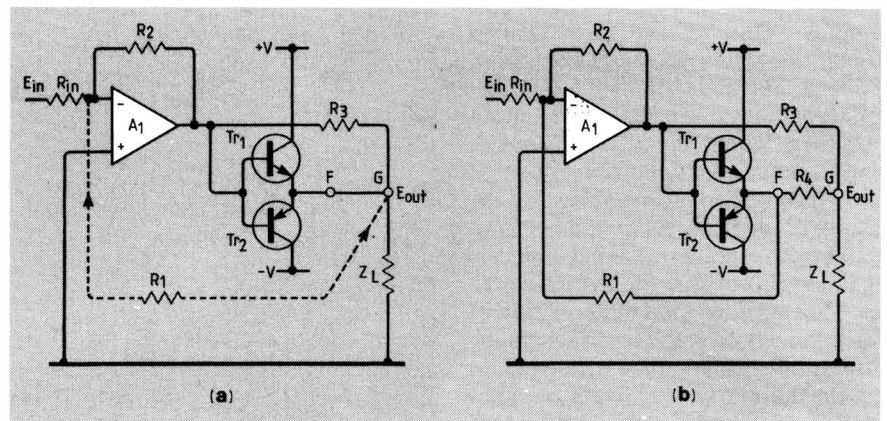
Certainly this design has excited an enormous amount of interest from other design engineers, if the number of published letters and articles seeking to explain or deny its operation is any indication. For me, the most intellectually satisfying explanation of its method of operation is that due to Baxandall<sup>6</sup> and is as follows.

Consider a simple amplifier arrangement of the kind shown in Fig. 5(a), consisting of a high-gain linear amplifier  $A_1$  driving an unbiased pair of power transistors  $Tr_1$  and  $Tr_2$  and feeding a load  $Z_L$ . Without any feedback, the input/output transfer curve of this circuit would have the shape shown by line (a) in Fig. 6, in which the slope would be steep from  $M'$  to  $N'$  while  $Tr_2$  was conducting, much flatter between  $N'$  and  $N$  while only amplifier  $A_1$  was contributing through  $R_3$  to the load current, and then steeper again from  $N$  to  $M$ , while  $Tr_1$  was conducting.

If overall negative feedback is applied via  $R_1$ , the kink in the transfer curve can be reduced, especially if the gain of  $A_1$  is very high, giving a more linear characteristic of the type shown by line (b) in Fig. 6. However, it would still be unsatisfactory.



**Fig. 4. Acoustical Quad current-dumping amplifier, similar to the Fig. 2 Sandman circuit except that it needs no presets or floating load.**



**Fig. 5. Operation of the Quad circuit. Basic arrangement of unbiased transistors at (a) is improved by addition of resistor  $R_4$ , which allows almost total elimination of output transistor distortion.**

What is required is some method of increasing the amount of feedback while  $Tr_1$  and  $Tr_2$  are conducting to reduce the overall gain so that the slope of the transfer characteristic  $M'-N'$  and  $N-M$  is identical to that  $N'-N$ .

This can be achieved, as shown in Fig. 5(b), by inserting a small resistor  $R_4$  between points F and G in the output feed from  $Tr_{1,2}$  and then deriving additional feedback from point F. If the values of  $R_{1,2}$  are correctly chosen in relation to the open-loop gain of  $A_1$ , and the output transistors  $Tr_{1,2}$  have identical characteristics, the distortion due to the unbiased output transistors vanishes.

Unfortunately, resistor  $R_4$  would be wasteful of power, so Walker and Albinson replace it with a small inductor and substitute a small capacitor for  $R_2$  to compensate for the frequency-

dependent impedance of the inductor.

While this substitution delivers a performance within the range expected from the component tolerances, it complicates the theoretical analysis of the circuit and has led to a lot of subsequent debate, in which the most detailed examination is that due to McLoughlin<sup>7</sup>. He makes a number of valid objections: that it is unlikely that the circuit will completely remove distortion, since no feedback amplifier can ever do this; that the distortion 'cancellation' depends heavily on the precision of the components in the 'bridge' network; and that it presumes that the output slope from  $M'$  to  $N'$  in Fig. 6 will be identical to that from  $N$  to  $M$ .

Nevertheless, the circuit works and gives a performance comparable to that obtainable by more conventional means, but without the need to set the

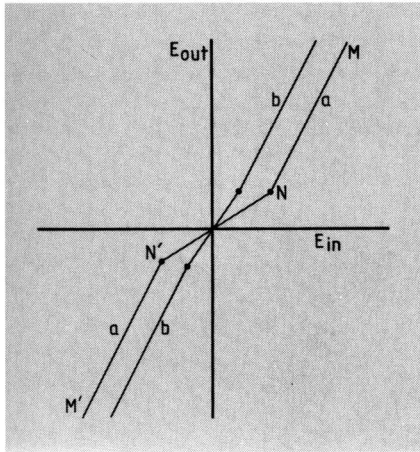


Fig. 6. Transfer characteristic of Fig. 5(a) circuit, with (b) and without (a) feedback.

output transistor quiescent currents – which was the initial objective.

**Power mosfets.** Junction transistors suffer from a number of inherent problems, such as hole storage and proneness to secondary breakdown and thermal runaway, which becomes more conspicuous when they are used as output devices. With a view to avoiding these problems. Sony introduced high-power junction fets, suitable for use as audio amplifier output devices, in the early 1970s and an amplifier using these was marketed.

However, the parallel development of the insulated-gate power mosfet overtook that of the power fet and, by the late 1970s, there was a range of robust devices with greatly superior characteristics to that of the bipolar junction transistor. Not only are they very fast but, if good chip geometry is employed, the relationship between gate voltage and drain current within the conducting region can be very linear indeed, which facilitates low-distortion push-pull operation. Their very high operating speed allows a substantial improvement to be made in the performance of a quite straightforward audio amplifier by the mere substitution of power mosfets for bipolar power devices, as for example in two designs of my own<sup>8</sup>.

With some exceptions, circuit designers have been slow to adopt these devices, in spite of their attractive features.

**Sandman's class S system.** A very interesting idea, introduced by Sandman<sup>9</sup> and somewhat confusingly labelled "class S" (this definition had been used before to refer to a valve grid-bias

mode) is shown in schematic form in Fig. 7.

This employs a high-gain error amplifier A<sub>2</sub> to sense the difference between the output of the small-signal driver amplifier A<sub>1</sub> and that from the unbiased output devices Tr<sub>1,2</sub> to drive these so that A<sub>1</sub> sees a very high impedance load, under which condition its performance approaches the ideal. As in the current-dumping circuit, the input amplifier provides a drive voltage to the load when the power output devices are non-conducting.

This idea has been adopted in several Japanese power amplifiers and a simplified version of the output stage of the Technics SE-A100 power amplifier – which is representative of all their current range – is shown in Fig. 8.

With reference to my earlier comments on the preoccupation of some manufacturers with what appear to be needlessly high specifications, this design is a typical example, in that it offers a very low steady-state THD figure (0.0002% THD at 1kHz), a very large bandwidth (0.8Hz – 150kHz) and a high

power output (240W into a 4Ω load), though with the penalty of a circuit of considerable complexity.

**Pseudo class A systems.** Various other circuit arrangements have been explored with the aim of avoiding the need for a pre-set, and perhaps critical value of output-stage quiescent current, without the thermal and other penalties incurred by a pure class A output stage, such as sliding bias or other non-cut-off layouts. Various names have been invented for these, such as "class AA" or "super A".

Of these, one of the more superficially appealing is the floating power supply arrangement in Fig. 9. In this layout, the output devices Tr<sub>2,3</sub> are operated in class A, with a collector current which is high enough to meet all the anticipated output current demands of the design, but with a supply voltage which is low enough that the total output stage thermal dissipation is within acceptable limits.

The output-stage low-voltage power supply is arranged to 'float', with its

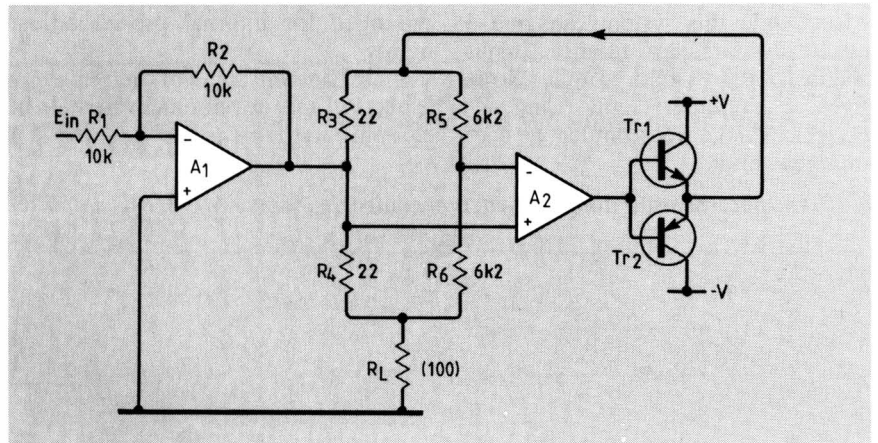


Fig. 7. Sandman's class S amplifier.

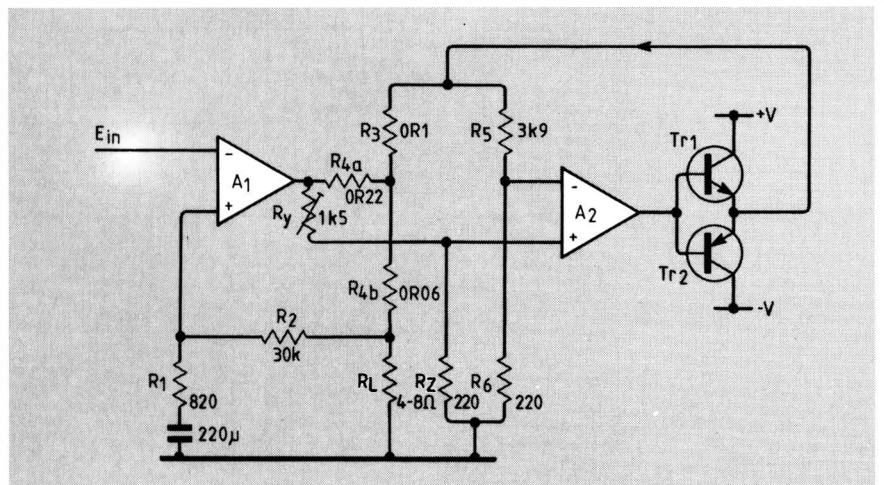


Fig. 8. Technics power amplifier output stage, using the circuit due to Sandman.

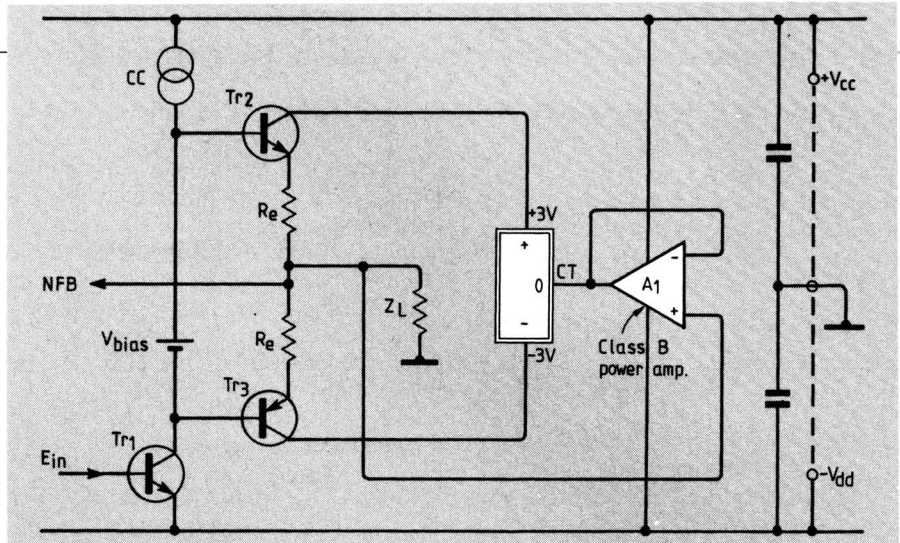
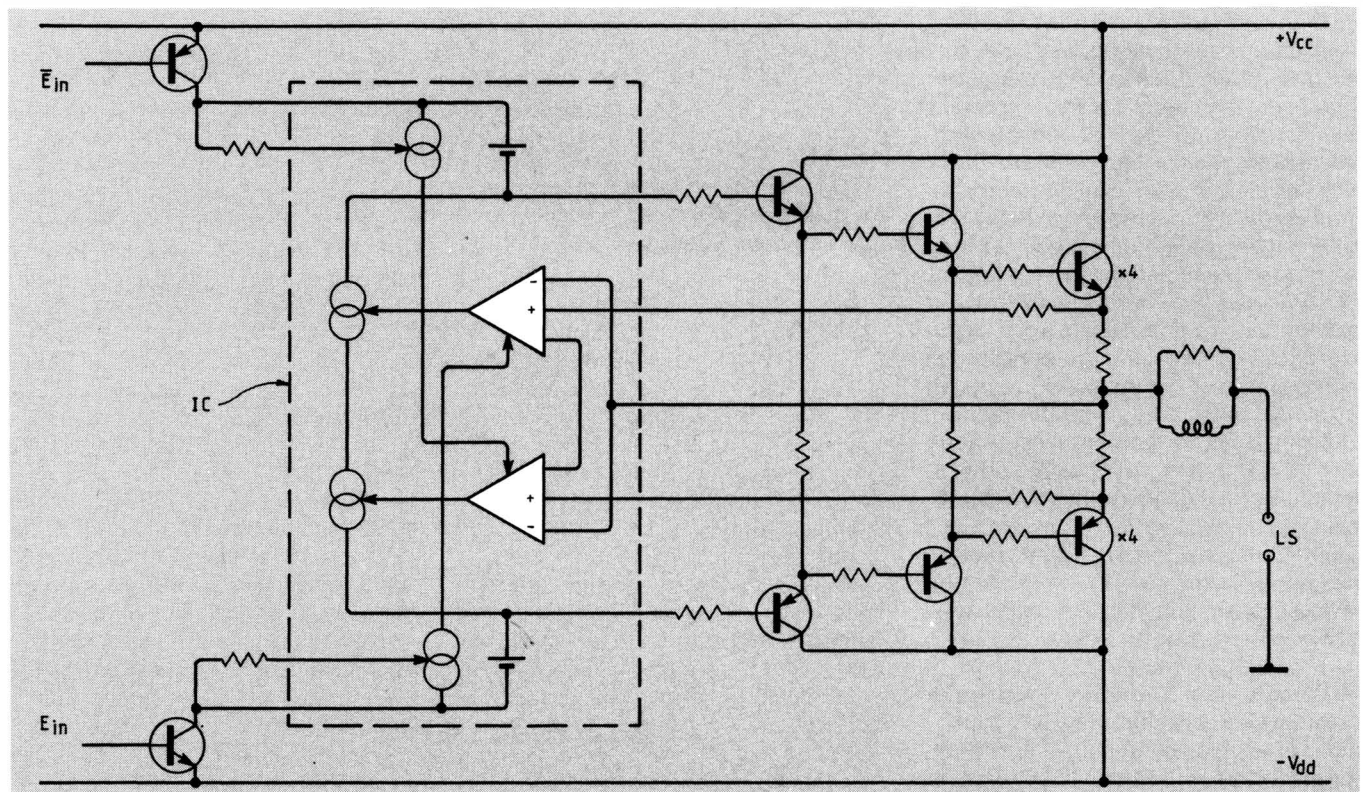
centre tap connected to the output of a high-power, unity-gain, class B power amplifier. There will, of course, be crossover-type discontinuities in the way in which this centre-tap voltage follows the input signal, but this will only appear as a modulation of the supply voltage applied to the output transistors, and it is presumed that the effect on the amplifier output will be negligibly small.

However, there is an inherent problem, which is that the load is connected to the 0V line, but the floating power supply is not. Since this is only returned to this line through the class B amplifier, it follows that this latter amplifier is in series with the load at all times.

The system therefore relies, in practice, on the ability of the negative-feedback loop signal to cause the preceding amplifier stages to supply a correcting signal to the class A output devices to remedy the deficiencies introduced by the class B supply-line driver, and these will only be remediable if the class B power supply driver stage is operated in class AB with some remedial quiescent current, which must be preset.

Also, while this system can give a good steady-state performance, it has problems, as have many other exotic designs, in handling steeply rising signals, which make up so much of programme material.

**Fig. 10. Output transistor quiescent-current control in Pioneer M-90 (BK) amplifier.**



**Fig. 9. Floating power-supply pseudo class A system.**

Another scheme which aims to provide the advantages of class A operation but with the economy of class AB is the so-called 'non-switching' layout due to Pioneer, used in their M-90 power amplifier, for example.

The layout used is shown in Fig. 10, in which a purpose-designed IC is used to monitor the quiescent current of each group of output transistors and ensure that it remains at the correct level, never approaching cut-off. This also avoids the need for internal pre-set adjustments.

I will examine some of the remaining aspects of this development in the concluding part of this article. ■

## References

1. Blomley, P. *Wireless World*, February 1971, pp. 57-61, and March 1971, pp. 127-131.
2. Black, H.S., US Patents, 1686792 and 2012671.
3. Sandman, A.M. *Wireless World*, October 1974, pp. 367-371.
4. Walker, P.J., *Wireless World*, December 1975, pp. 560-562.
5. Sandman, A.M., *Wireless World*, April 1976, p. 54.
6. Baxandall, P.J., *Wireless World*, July 1976, pp. 60-61.
7. McLoughlin, M., *Wireless World*, September 1983, pp. 39-43, and October 1983, pp. 35-41.
8. Linsley Hood, J.L., *Hi-Fi News and Record Review*, January 1980, pp. 67-71, and December 1980, pp. 83-85.
9. Sandman, A.M., *Wireless World*, September 1982, pp. 38-39.

Since it is preferable to achieve a high degree of linearity in the transfer characteristics of the amplifier without having to use large amounts of negative feedback to straighten out the kinks, designers have paid much attention to the design of those stages which provide the bulk of the voltage gain within the power amplifier.

### Gain stage design

The principal techniques at the disposal of the circuit designer in his pursuit of greater linearity are the use of long-tailed pair gain stages, since these tend to lessen the generation of even-order distortion components; the cascode connection of the devices in the various ways shown in Fig. 1, because this isolates the amplifying device from the output voltage swings; and the use of highly symmetrical driver stage layouts, which can lessen problems due to slew-rate limiting. All of these methods are exploited, in various combinations, in contemporary circuit designs.

It is practicable to obtain high gain with wide bandwidth simply by cascading a series of amplifier stages, as in the relatively early design due to Lohstroh and Ojala<sup>1</sup> shown in outline in Fig. 2, but the cumulative phase errors of succeeding stages make overall loop stability more difficult to achieve.

Nevertheless, this approach has been adopted commercially; a design employed by Pioneer in their M-90 power amplifier, shown schematically in Fig. 3, shows strong similarities to the Lohstroh/Ojala layout. This Pioneer design also shows a trend, which is increasingly favoured in Japan, of using cascode-connected (monolithic) dual-junction fet inputs stages, because of the ease of matching the DC offset characteristics in a monolithic pair, and the greater input linearity of fets in comparison with bipolar transistors.

The bipolar cascode devices,  $Tr_2$  and  $Tr_4$ , which can be high-voltage working types, then allow the supply line voltages to be chosen without the constraints imposed by the relatively low gate/drain breakdown voltages of the fets.

# SOLID-STATE AUDIO POWER

In this final part, John Linsley Hood considers gain stages and power supplies, and takes a quizzical look at testing and specifications.



The use of high-voltage, small-signal mosfets in place of cascode isolated junction fets as the input devices, as adopted in a recent design of my own<sup>2</sup> shown in Fig. 4, allows a simpler layout without loss of performance, provided that some initial set-up adjustment is made to compensate for possible bias-voltage differences between the two input devices.

The performance of the gain stage is enhanced by cascode connecting the driver stage preceding the output emitter followers, as shown in the two designs of Figs. 5 and 6 due to Borbely<sup>3,4</sup>, since this stage will be required to handle a large signal-voltage swing.

Cascode connection, in this case, improves the effective linearity of the input device, particularly in respect of collector voltage modulation of the current gain (Early effect), and also eliminates unwanted effects due to the collector/base feedback capacitance.

Figure 7 shows an elaboration of this layout used in the Technics SE-A100 amplifier, in which the combination of the emitter-follower group  $Tr_{8,9}$  and the current mirror formed by  $Tr_{10,11,15}$  is used to achieve a symmetrical drive system from a less complex single-ended input stage, which makes it easier to control the output stage quiescent current than with a fully symmetrical driver layout, even though this may be theoretically superior.

Although the availability of high-

Fig. 1. Fet/bipolar cascode combinations, giving good input/output isolation. Circuit at (a) gives high gain, high output impedance and high-voltage operation; (b) gives very high  $Z_{in}$ , high  $Z_o$  and high voltage; (c) very high  $Z_{in}$  and  $Z_o$  and low/medium voltage; (d) high gain, very high  $Z_o$  and low/medium voltage.

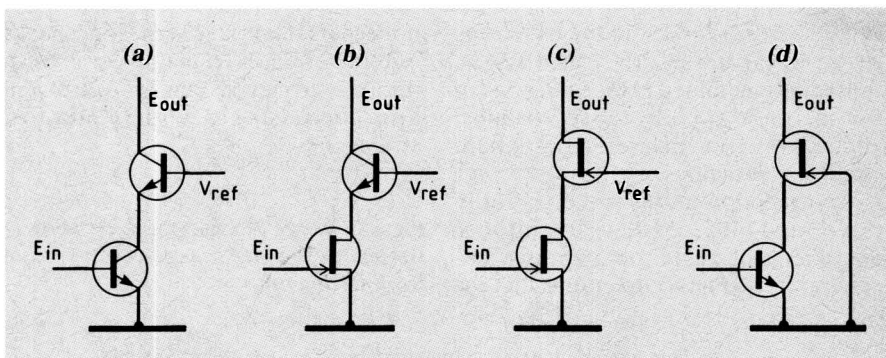
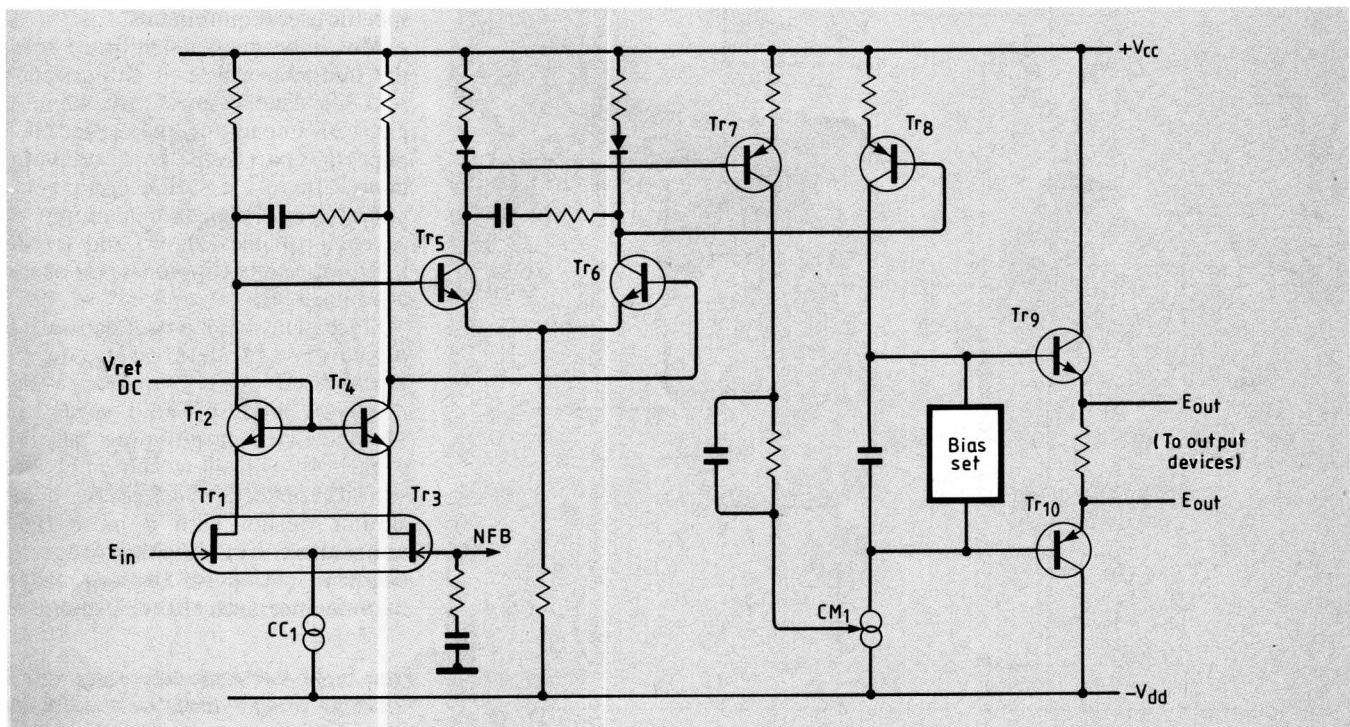
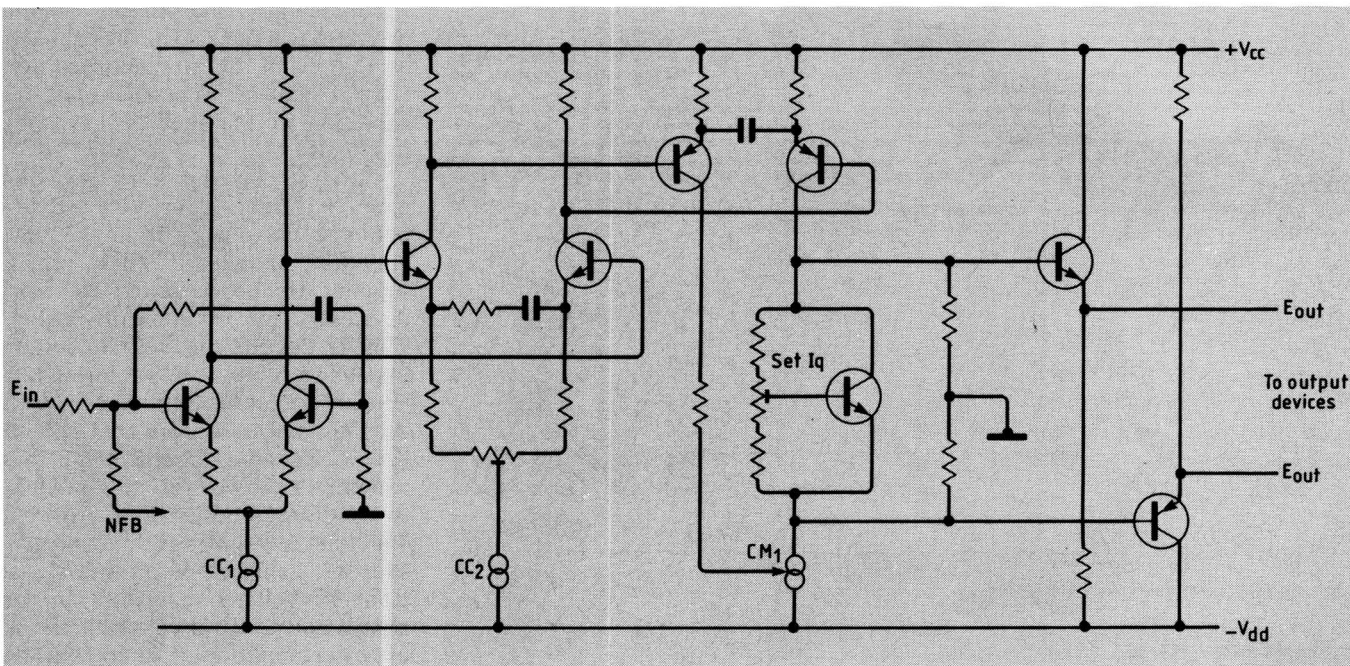


Fig. 2. High-quality amplifier design by Lohstroh and Otala, giving high gain and wide bandwidth by the use of several gain stages.

Fig. 3. Pioneer's M-90 amplifier, a commercial embodiment of the Fig. 2 circuit.

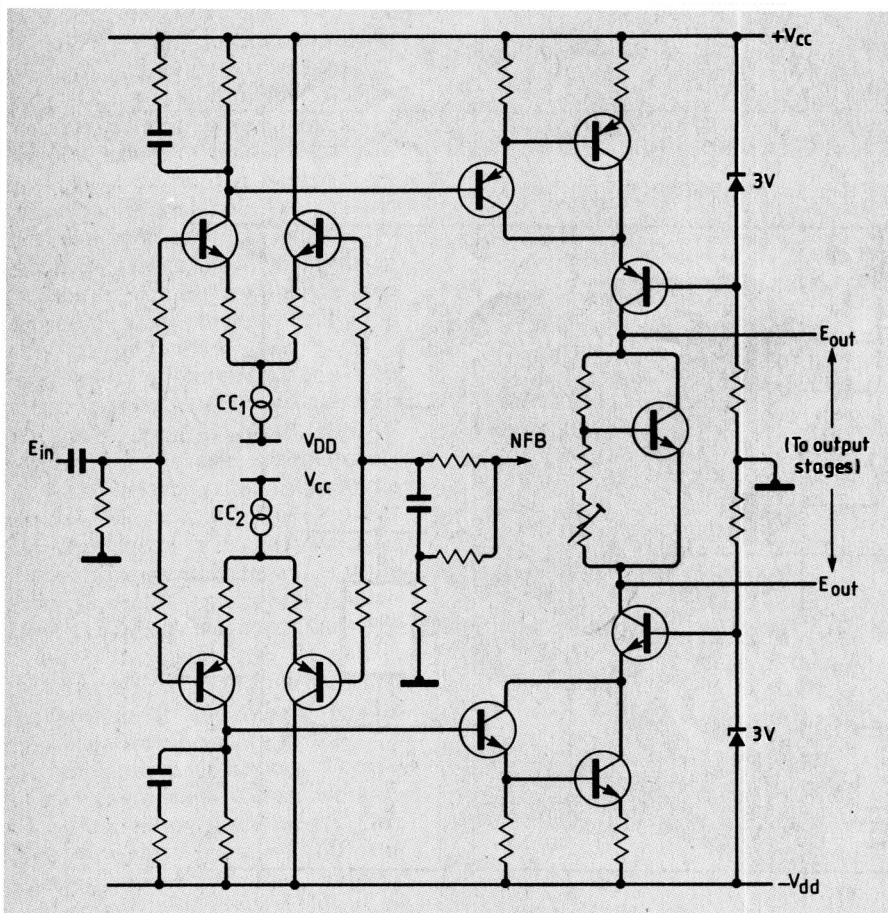
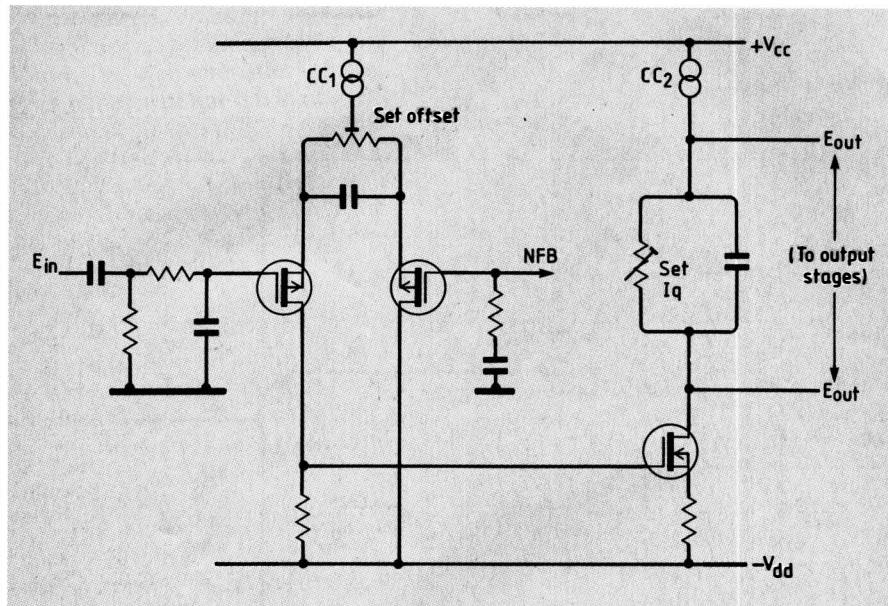


voltage devices has led to the increasing use of linear ICs in driver gain stages, those designs aimed at the upper end of the market appear to rely almost exclusively on discrete-component circuit constructions.

An exception to this is the use, as in the Quad 405, 510, 520 and 606 amplifiers, of an IC op-amp as a DC comparator, (Fig. 8), to ensure that the

no-signal DC voltage at the loudspeaker output terminals remains close to the desired zero level. This is a worthwhile and increasingly widely adopted stratagem.

*Fig. 4. High-voltage mosfets allow a simpler design at the expense of freedom from setting up.*



## Power supplies

From the point of view of the purist, there is no substitute for an electronically stabilized supply as the DC source for the power amplifier, since this will provide rails of known and precisely controlled potential, largely free from noise and ripple and having a low source impedance.

It also confers the advantage, in the case of a power amplifier, that the output power available can be precisely specified and unaffected by short-term changes in the mains supply voltage. Instantaneous power-supply clamping or shut-down can also be brought about in the event of an abnormal load-current demand or a DC-offset fault condition at the loudspeaker output terminals.

Such a stabilized power supply offers many advantages, including that of better sound quality from the power amplifier, particularly where separate supplies are provided for the output devices and the preceding driver stages. This is due to the very low source impedance of the supply lines, which appears to confer both a more 'solid' bass, as well as a more precise stereo image. Suitable designs tend to be complex, however, as in a published twin DC supply design of my own<sup>5</sup>.

From low-voltage preamplifier supplies, stabilized supply lines derived from IC voltage regulators are now almost universally used but, in the case of power amplifiers, a rigidly controlled DC supply would not meet some specific user requirements.

This is because a significant part of the market consists of enthusiasts for rock and similar music, for whom the physical impact of the sound is an important part to the enjoyment of the music. In this use, the equipment is operated at as high a sound output level as circumstances allow, and freedom from noticeable clipping is a substantial advantage.

Since many peak power demands are of relatively brief duration, an unstabilized power supply, having a relatively high off-load supply line voltage with large-value reservoir capacitors, will allow the amplifier to sound appreciably 'louder' than a similar design with a more rigidly controlled but lower-voltage DC supply. This is an aspect few manufacturers can afford to ignore.

*Fig. 5. Linear high-gain stage due to Borbely, using symmetrical configuration.*

Figure 9 shows a typical modern power supply, with entirely separate supplies for each channel, and very large-value reservoir capacitors. Clearly, the output current from such a supply could be highly destructive of the loudspeaker system in the event of a component failure and various protection systems are used, ranging from simple fuses in the output lines to elaborate relay protection systems, such as that shown in Fig. 10.

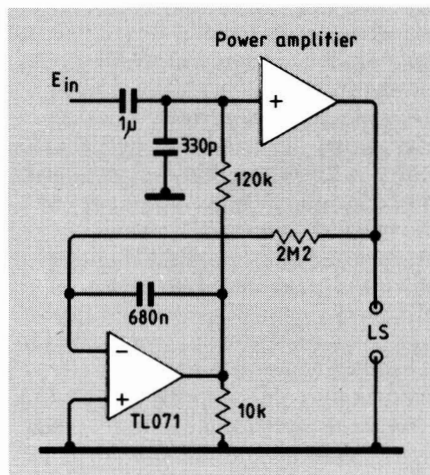
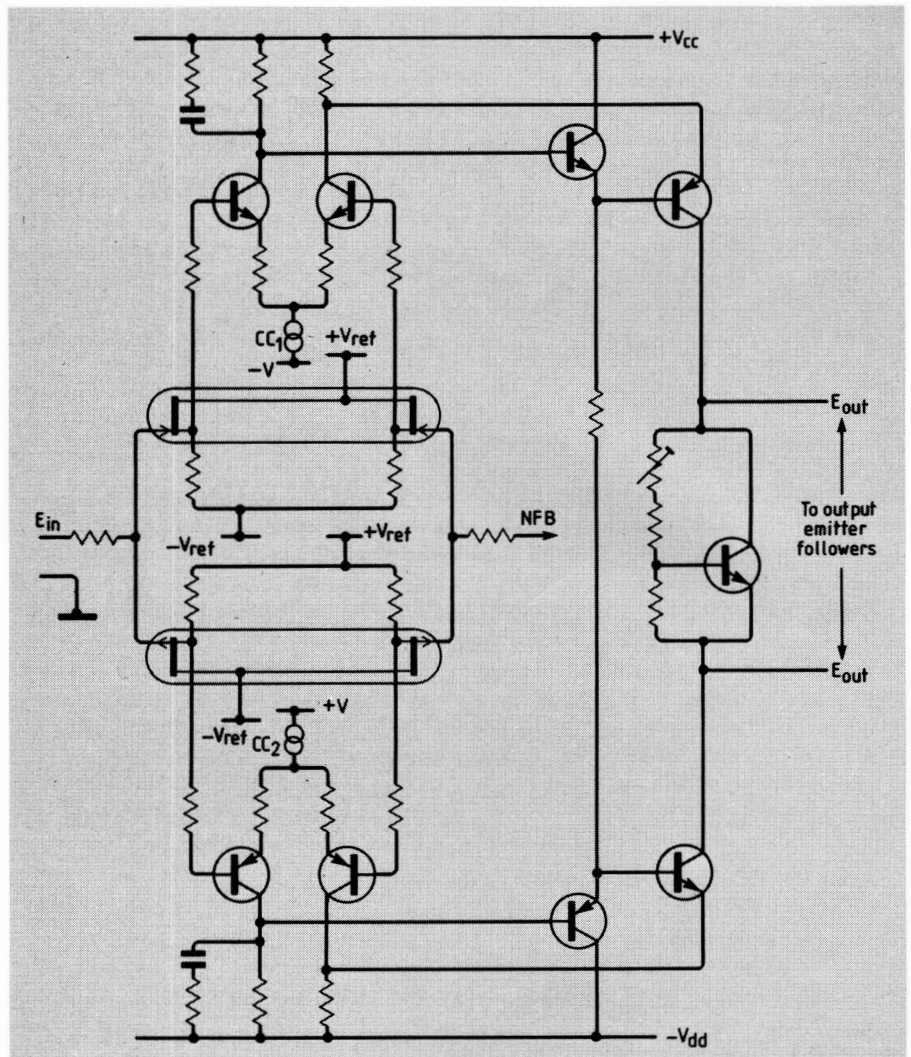
However, with all of these electromechanical components included within the loudspeaker output line, there remains the real possibility of poor electrical connections through mechanical wear or contact corrosion, which can lead to high resistance junctions. There is also the possibility of rectifying effects, which are of much greater audible significance than any benefits thought to be conferred by ultra-low resistance speaker cables.

**Amplifier testing**

In an ideal world, there would be some clearly understood and universally agreed set of standards by which the performance of an amplifier – or any other component in the sound reproduction chain – could be assessed.

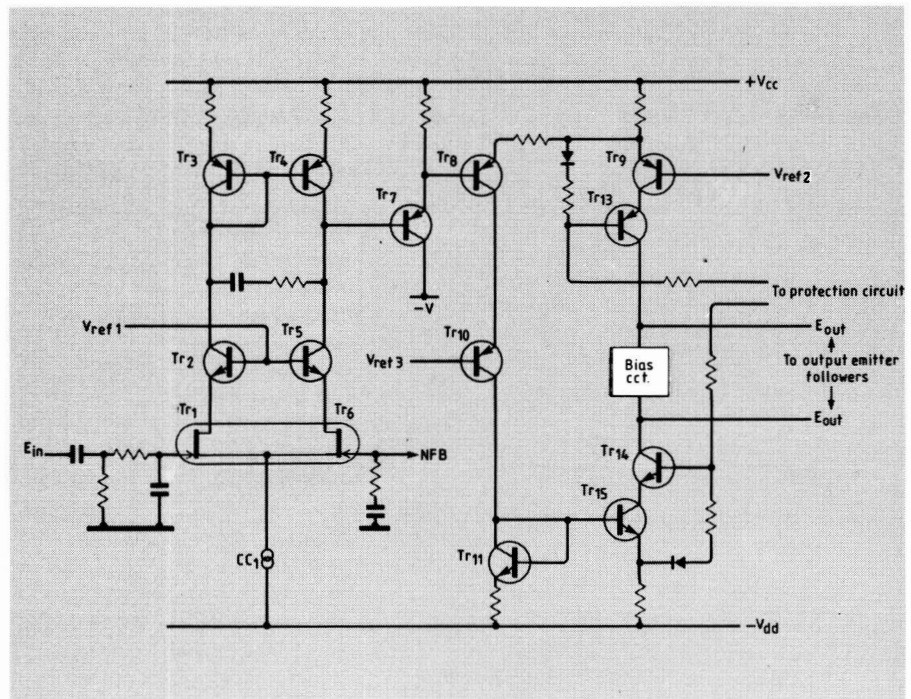
Some of the design errors which arose in the early days of transistor amplifiers disclosed inadequacies in the test

**Fig. 6. Another Borbely cascode design, with source-followers.**



**Fig. 8. Output DC level correction used by Quad in which the op-amp maintains the no-signal direct voltage near zero.**

**Fig. 7. Single-ended cascode input stage by Technics makes for ease of quiescent current adjustment.**





methods then employed. Sadly, thirty years later, we are still some way from a complete understanding of the types of technical specification we should seek to meet, or of the relative acoustic significance of the known residual errors.

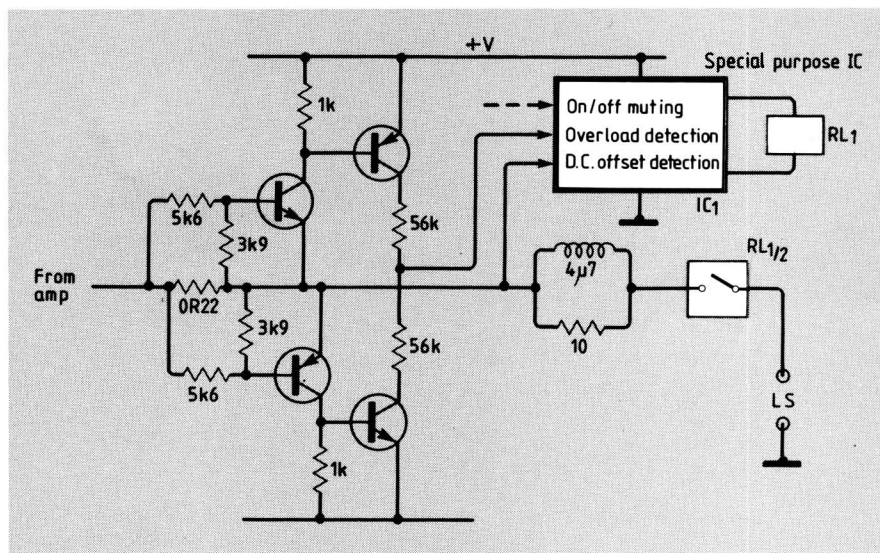
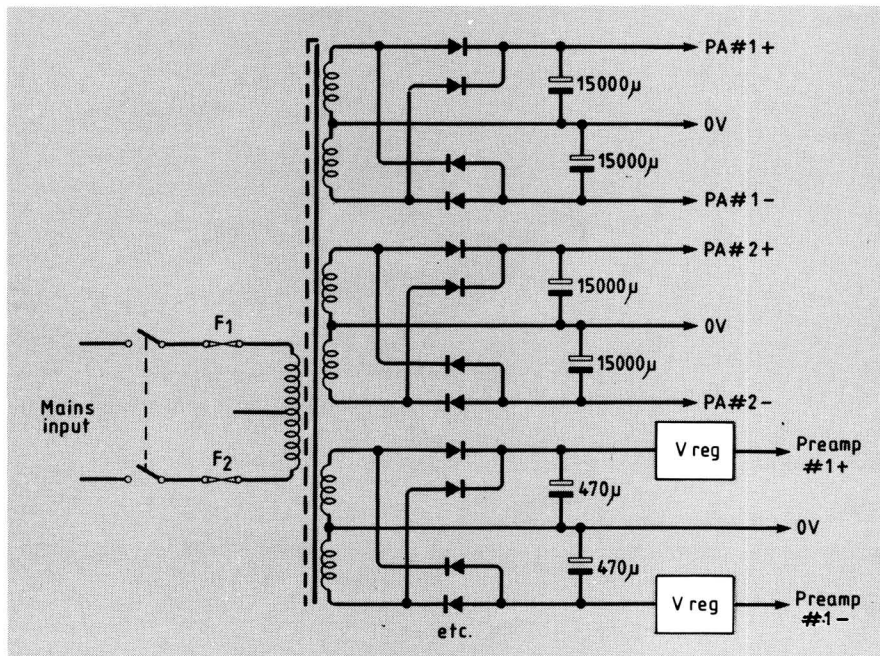
Part of this problem is due to clear differences in their response to instrumental evaluation between the three groups of customers; the classical music devotee, the rock music enthusiast and the relatively naive, and musically uninterested 'man in the street'.

In classical music and traditional jazz played on acoustic instruments, a direct comparison is possible between the sound of the original performance and that of the reproduction, allowing for

differences in the acoustic ambience of the settings; the importance of residual defects in reproduction, so far as these are identifiable, can be quantified.

Some of the early public demonstrations staged by G. A. Briggs of Wharfedale and P. J. Walker of Quad, in which live and reproduced music were directly compared in a side-by-side demonstration, showed that even in those days the differences could be surprisingly small and encouraged the belief that the performance tests employed were adequate to assure satisfactory performance, as they could

**Fig. 9. Simple unstabilized power supply for output stages used even in high-quality amplifiers.**



well have been for the equipment then being used.

For the relatively unsophisticated buyer of equipment, the important factors are physical appearance, the number of facilities it offers, its apparent value for money and its numerical performance specifications, such as power output, bandwidth, and steady-state harmonic and intermodulation distortion factors.

The fact that very highly specified power amplifiers may not sound any better, and perhaps even worse than systems which are less well specified, has cast some doubt on the value of many performance measurements. This doubt is encouraged by the growing use of up-market equipment for the reproduction of music originating mainly from electronic or electronically assisted instruments – which definition must also include the human voice, where this is augmented by a microphone and amplifier – and fed directly on to tape.

This music is also likely to have been extensively modified during the recording process, so that the performance is heard for the first time when the disc or tape is replayed. The judgment of the listener will therefore be based less upon whether the reproduced sound is accurate than on whether it is pleasing to the ear.

Whether it is warranted or not, enthusiasts insist that there are differences in the listener appeal of the various available units and that these differences may not be measurable by any of the normally specified performance parameters. Guidance, when needed, must therefore be sought elsewhere.

A wide range of periodicals exists to cater for this need and also, perhaps, to reinforce the belief that the respective merits of various brands of equipment can only be assessed by comparative listening trials carried out by (their own) skilled and experienced reviewers.

Clearly, the absence of valid numerical or instrumental standards for defining subjective amplifier performance is a matter of wide concern, and various attempts have been made to set matters straight.

To involve the ear of the listener in the assessment of performance, Colloms<sup>6</sup> and Baxandall<sup>7</sup> almost simultaneously proposed the substitution of the amplifier under test

**Fig. 10. Typical commercial speaker protection and switch-on/off muting circuit.**

for a nominal (phase-corrected) straight wire, using a circuit layout of the kind shown in Fig. 11. Perhaps predictably, the conclusions reached by these two authors differed, with Colloms claiming that there were significant differences which could be detected by this method and Baxandall asserting that all competently designed units; operated within their limits, will sound identical.

An early observation of audio enthusiasts was that, in spite of their generally poorer specifications, valve amplifiers "sounded better" than transistor amplifiers. This was probably because the valve amplifiers had a more gradual overload characteristic than their transistor equivalents, especially since most solid-state amplifiers would use output-transistor protection circuitry, which would impose a rigid limit on the permissible output current into a short circuit or low-impedance load. Valve amplifiers did not impose this output current limitation and for both of these reasons could sound significantly 'louder' than notionally more powerful transistor operated systems.

In an attempt to test the validity of these claims for the audible superiority of valve amplifiers, the Acoustical Manufacturing Company (Quad) commissioned a series of double-blind group listening trials, reported by Moir<sup>8</sup>, in which the panel was selected to include people who had published their beliefs that there were significant differences between amplifier types and that valve amplifiers were superior. In the event, the conclusions of this trial were that there was no statistical significance in the group preferences, individually or collectively, between the Quad 303 and 405 transistor amplifiers, or between either of these and the Quad II operated amplifiers.

However, a possibly important factor was that the output signals from the amplifiers were monitored with an oscilloscope to ensure that at no time were the output levels high enough to cause clipping, however briefly.

As an extension to this valve versus transistor debate, Hiraga<sup>9</sup> tried to relate the claimed sound differences between the two amplifier types to test results derived from wide-band spectrum analysis. In general, his findings confirmed that the listener did not necessarily prefer undistorted signals.

A further attempt to provide a test method to give better correlation with the subjective assessment than simple THD or bandwidth measurements was evolved by the BBC and described by

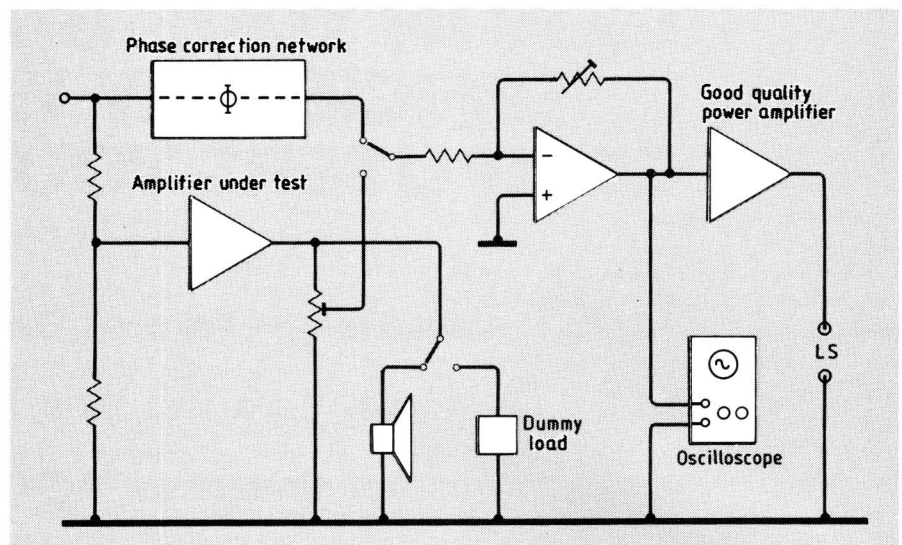


Fig. 11. Circuit for "straight-wire" substitution test on audio amplifiers.

Belcher<sup>10</sup>, using weighted pseudo-random noise signals followed by a comb-filter rejection network.

This gave very good correlation with a listening-panel assessment of sound quality impairment through various causes, which showed that the nature and linearity of the transfer characteristic of the system was important. This conclusion was corroborated by Hirata<sup>11</sup>, who evolved a test method based on an asymmetrical pulse waveform input, in an attempt to discover why it was possible to hear and identify the audible defects of an amplifier in the presence of much larger defects introduced by the loudspeaker.

Unfortunately, the gulf between engineers and the subjective-sound fraternity still remains, one side claiming that any differences between well designed amplifiers will be vanishingly small, and the other asserting that dramatic changes in performance can be made by such unlikely actions as replacing the standard mains cable with a more expensive one.

The absurdity of some of these claims provoked Self<sup>12</sup> into a defence of engineering standards against the metaphysical assertions of the 'add-on' fraternity. As I indicated in a subsequent letter<sup>13</sup>, I feel that we may still have things to learn, outside the comfortable realms of the steady state.

As engineers, we have made mistakes in the past through the lack of stringency in the tests we applied. This experience must make us more cautious in claiming perfection as a result of favourable responses to a limited number of possibly inappropriate test

measurements; we may still have overlooked something.

For myself, I believe that some audible differences do remain between apparently impeccably specified amplifiers, particularly where these are based on dissimilar design philosophies and I think some of these audible differences are related to quite clearly visible, and measurable, differences in their step-function response characteristics. There are certainly other things which also have an effect on sound quality which we could measure, if only we knew where to look. ■

#### References

1. Lohstroh, J., and Ojala, M., AES 44th Convention, Rotterdam, 1973, Ref. H6
2. Linsley Hood, J. L., *Electronics and Wireless World*, March 1989, pp. 261-264.
3. Borbely, E., *Wireless World*, March 1983, pp. 69-75.
4. Borbely, E., *Audio Amateur*, February 1984, pp. 13-24.
5. Linsley Hood, J. L., *Electronics and Wireless World*, May 1989, pp. 524-527.
6. Colloms, M., *Hi-Fi News and Record Review*, October 1977, pp. 83-85.
7. Baxandall, P. J., *Wireless World*, November 1977, pp. 63-66.
8. Moir, J., *Wireless World*, July 1978, pp. 55-58.
9. Hiraga, J., *Hi-Fi News and Record Review*, March 1977, pp. 41-45.
10. Belcher, R. A., *Wireless World*, May 1978, pp. 36-41.
11. Hirata, Y., *Wireless World*, October 1981, pp. 49-52.
12. Self, D. R. G., *Electronics and Wireless World*, July 1988, pp. 692-696.
13. Linsley Hood, J. L., *Electronics and Wireless World*, September 1988, pp. 860-861.

keith@snook.eu