

Flowmeter Installer Training



Paul B. Rodrigue, NRCS, Supervisory Engineer, Area IV (Delta)
in cooperation with
MDEQ, YMD, MSU Extension, DREC, Delta F.A.R.M.

(Disclaimer: Trade names/products are used solely to provide specific information and for instructional purposes. Mention of a trade name does not constitute a guarantee of the product by the U.S. Department of Agriculture or any other agency or individual nor does it imply endorsement by the Department or the Natural Resources Conservation Service over comparable products that are not named.)

Flowmeter Installer Training

Purpose: to provide training to persons other than well drillers or pump installers licensed by MDEQ as part of the Delta Voluntary Metering Program

Topics:

- 1) Ordering the meter
- 2) Installing the meter
 - Upstream and downstream distances
 - flow straighteners
 - bolt on saddle meters
 - flow tubes
- 3) Reading the meter

Note: in no case does a flowmeter installation automatically require a 1D rise downstream of the flowmeter.

http://www.deq.state.ms.us/
or type MDEQ into a search engine (GOOGLE, BING, etc.)

The screenshot shows the MDEQ website in Internet Explorer. The browser's address bar displays <http://www.deq.state.ms.us/>. The website features the MDEQ logo on the left, which consists of three interlocking circles representing water, air, and land. The main navigation bar includes links for HOME, PROGRAMS, enDX, eDMR, enSEARCH, CONTACT, NEWS, TOPICS, and SEARCH. A sidebar on the left contains a newsletter subscription checkbox and a list of links such as About MDEQ, enHance, Air Quality Index, Oil Spill Links, and Delta Metering Program. A red arrow points to the Delta Metering Program link. The main content area includes a large image of a butterfly on a flower, a section for Mississippi Beach Monitoring, and various program announcements. The footer contains the MDEQ mission statement: "The Mississippi Department of Environmental Quality is responsible for protecting the state's air, land, and water. Our mission is to safeguard the health, safety, and welfare of present and future generations."

http://www.deq.state.ms.us/index.nsf/page/LWV_DeltaMeteringProgram?OpenDocument

File Edit View Favorites Tools Help

USAJOBS - Search Jobs Suggested Sites IDEA Home Page (2) FY14RegionalPaymentSche... Thrift Savings Plan Topo Maps WV Rader WV Forecast Web Soil Survey WebTCAS addVANTAGE Pro 6

MDEQ - Delta Metering Program

MISSISSIPPI DEPARTMENT OF ENVIRONMENTAL QUALITY

HOME PROGRAMS enDX eDMR enSEARCH CONTACT NEWS TOPICS SEARCH

Subscribe to the MDEQ Newsletter

Delta Metering Program

As part of ongoing efforts to effectively manage the use of the Mississippi River Valley Alluvial Aquifer (MRVA), the MDEQ Office of Land and Water Resources has adopted specifications for flow meter installation and a list of approved flow meters for agricultural uses.

[MDEQ Specifications for Well Meter Installation](#)
[MDEQ List of Approved Meters for Agricultural Wells](#)
[Procedure for Adding a Meter to the MDEQ List of Approved Meters](#)

MDEQ encourages producers to install flow meters and participate in the Voluntary Metering Program for MRVA agricultural wells.

[Steps for participation in the Voluntary Metering Program](#)
[Voluntary Metering Participation Form](#)
[Meter Installation Training Presentation](#)
[Worksheet to assist in ordering correct meter](#)

Please direct any questions you may have about the use of flow meters for managing the MRVA or about the Voluntary Metering Program to:

Paul Parrish 601-961-5324 PParrish@deq.state.ms.us	or	Wayne Williams 601-961-5610 WWilliams@deq.state.ms.us
--	----	---

Copyright 2007 © Mississippi Department of Environmental Quality.
Website Disclaimer

Done Internet | Protected Mode: On 100%

Start [Icons] 6:39 AM 10/25/2013

This page contains all the latest, up-to-date information for the Delta Metering Program

Voluntary Metering Requirements

Specifications for Metering Groundwater Withdrawals

- Any fixed meter installed before July 31, 2013, will qualify for inclusion in the voluntary meter program.
- To qualify for inclusion in the voluntary meter program, any meter installed after July 31, 2013, a) must measure 100% of the well output; b) must be installed to meet manufacturer's requirements; c) and must be on the MDEQ Approved Meter List .

This training is for installing to the Voluntary Metering Program only.

Note: there are differences in NRCS Flowmeter Designs associated with NRCS financial assistance programs.

Flow Measurement:

Flowrate may be measured by measuring the velocity of fluid over a known area.

$$Q = V * A$$

where,

Q = flowrate in cubic feet per second (cfs)

V = velocity of the liquid, feet per second (fps)

A = cross-sectional area of flow, square ft (ft²)

Flowmeters typically used in agriculture (propeller, ultrasonic, etc.) measure the velocity of water in the conduit, and use the fixed cross-section of the pipe to calculate flow rate.

All methods require an accurate measurement of the inside diameter for the flow rate to be correct.

Registers convert the cfs to other units for display, e.g. gallons per minute, acre-inches per hour.

$$1 \text{ cfs} = 1 \text{ ac-in/hr} = 448 \text{ gallons per minute (gpm)}$$

$$1800 \text{ gpm} = 4 \text{ ac-in/hr}$$

**Example: 3 inch furrow application to 40 acres = 120 ac-in/4 ac-in/hr = 30 hours
at 1800 gpm pumping rate**

Typical Meter Manufacturer Installation Recommendations

- Propeller meters should be installed a minimum of 10 diameters downstream of any obstructions. Flowmeters are velocity sensing devices and are vulnerable to certain upstream disturbances. Because of this, meters need certain lengths of straight pipe runs before and after the meter. U.S. distances can be reduced with use of a flow straightener.
- These distances usually relate to the diameter of the pipe used. Obstructions can include elbows, valves, pumps, and changes in pipe diameter. The uneven flow created by these obstructions can vary with each system. If your application provides for more than five diameters of upstream run, use the available distance.
- Downstream (D.S.) run should be two diameter of straight pipe length after the meter.

Flowmeter Installation: Groundwater

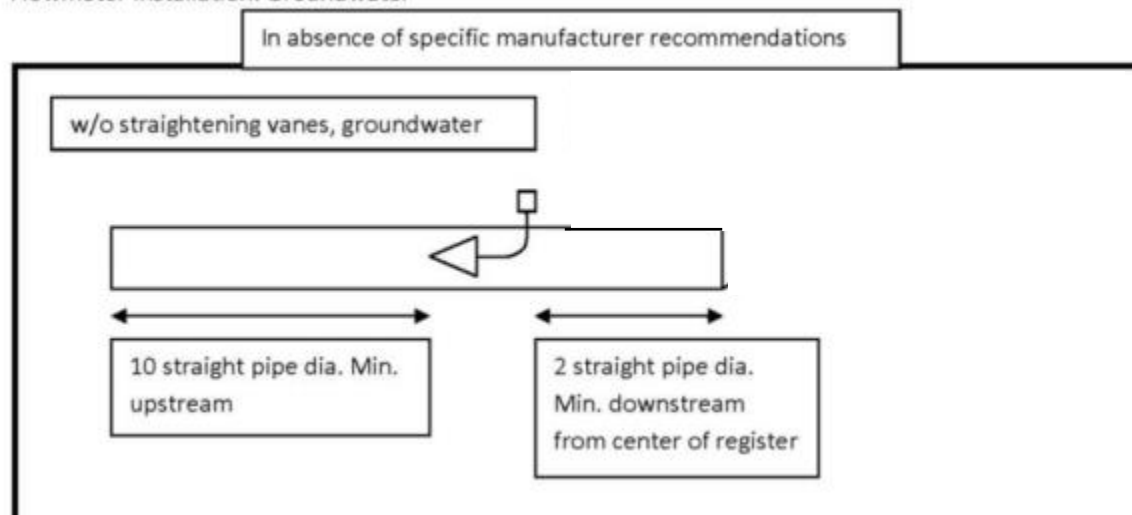

U.S. = upstream
D.S. = downstream

I.D. = inside dia.
O.D. = outside dia.

OTHER INSTALLATION CONSIDERATIONS

- All propeller flowmeters are calibrated for a full pipeline. If the pipe is not completely full, the flowmeter will over register the flow. Although a minimum line pressure is not necessary for an accurate measurement, a full pipe is necessary. A 1D rise D.S. of the flowmeter insures full pipe flow, but is not required.
- Flowmeters can be mounted either horizontally or vertically. Although most applications are horizontally oriented, mounting the meter vertically actually offers some slight advantages. One reason is that gravity has a more pronounced flow conditioning effect with lines in the vertical (as opposed to horizontal) orientation. The intended configuration of the meter must be specified when ordering. If installing in a center pivot, identify system pressure.
- With the meter installed, check the rate-of-flow indicator. It should be stable to the point that it can be easily read. Some movement is normal, but if the indicator is moving erratically back and forth, disturbances exist and meter accuracy decreases. If you suspect a problem, please refer to the INSTALLATION INSTRUCTIONS section or the MAINTENANCE AND TROUBLESHOOTING section.

If an air vent mounted on the top of the pipe is closed, pipe is full.
If it is not closed, likely not flowing full.



Flow Tubes

Flow tubes are manufacturer supplied sections of pipe that contain the saddle flow meter, flow straightener, and necessary upstream and downstream distances for accurate flow readings. Flow tubes are selected by the pipe size they are to be installed in line with.

Flow tube length requirements per diameter are:

6" pipe size	– 30" tube length
8" pipe size	– 34" tube length
10" pipe size	- 40" tube length
12" pipe size	- 46" tube length

Flow tubes with flow straightener are only to be installed with groundwater sources.

Supplier manufactured flow tubes must consist of flow straightener and meter in appropriate length tube with meter certified for specific I.D. of tube material.

Key Points:

- Flow Tubes insure best chance of a good installation and operation and require least distances. A flow tube consists of a know pipe size, flow straightener, flowmeter and all required U.S. and D.S. lengths within the tube length.
- Flow tube length requirements per diameter are typically:
 - 6" pipe size – 30" tube length
 - 8" pipe size – 34" tube length
 - 10" pipe size - 40" tube length
 - 12" pipe size - 46" tube length

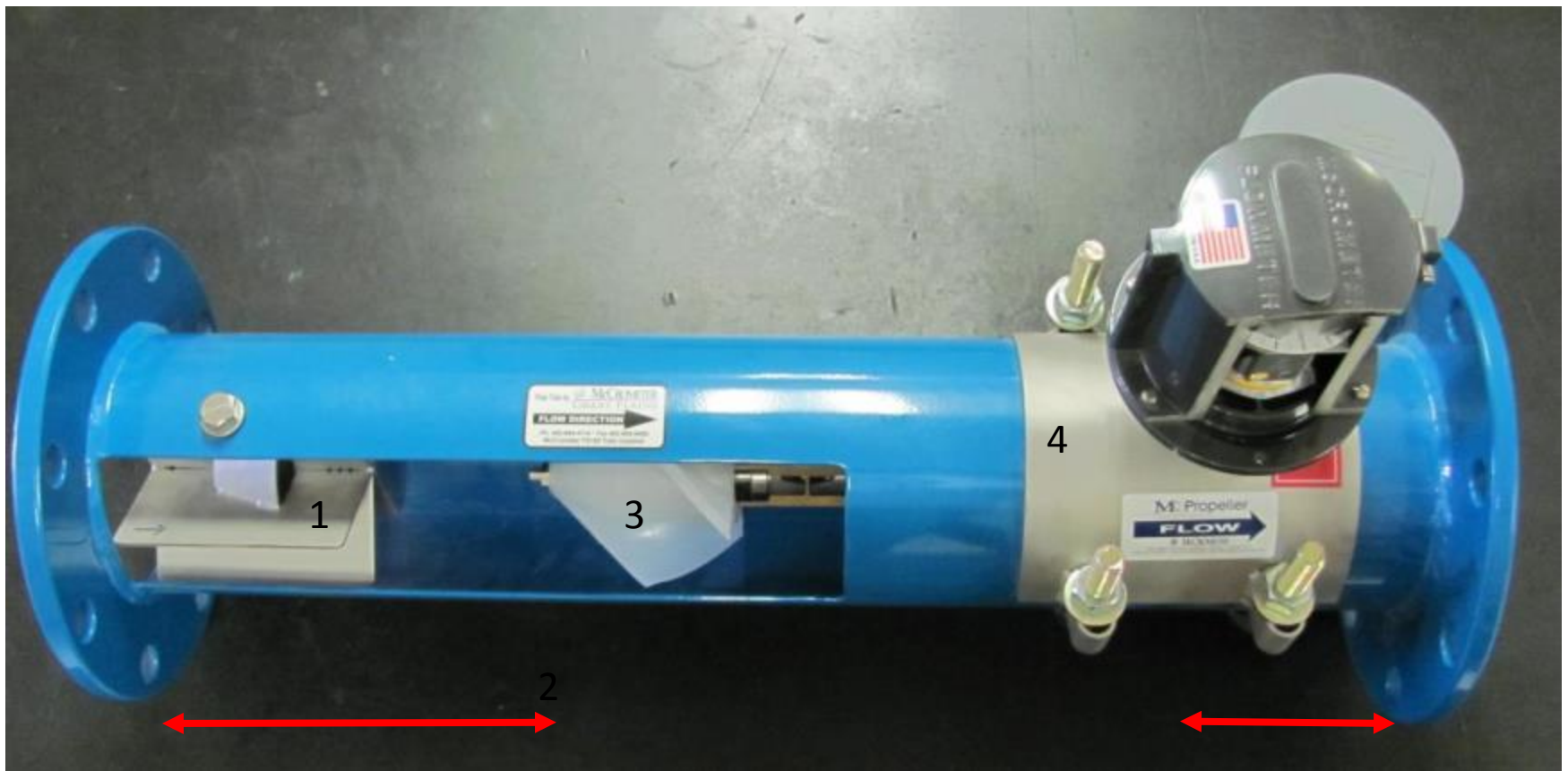

A manufactured flow tube has all required distances, components, with a standard pipe I.D. to insure the best accuracy possible. This one is a flange mount.

- 1) Flow Straightener (not the same as straightening vanes, a 3 part unit, which requires more U.S. distance)
- 2) Proper U.S. and D.S. distances
- 3) Propeller properly sized for pipe I.D. and meter is properly located in pipe length
- 4) Saddle properly sized for O.D.

Flowmeter Installation: Groundwater

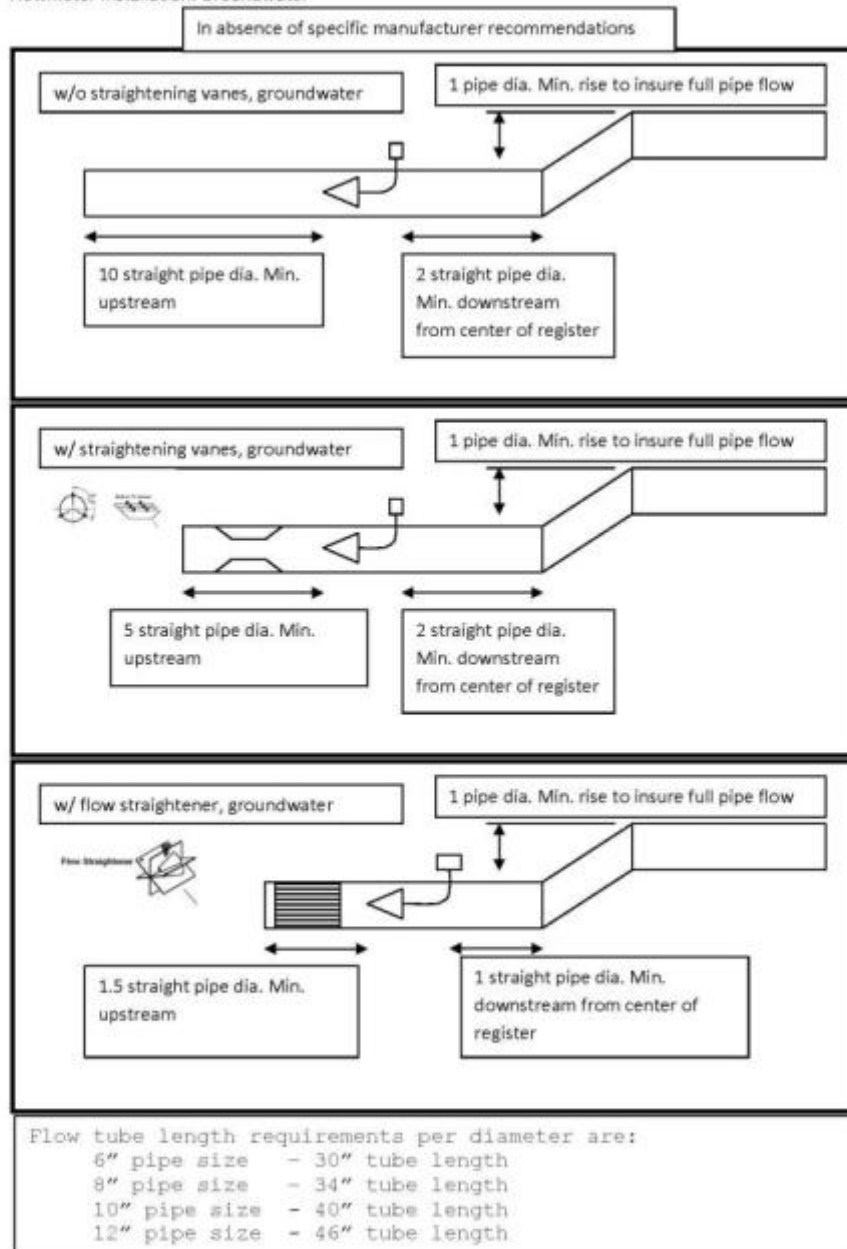

Key Points:

“In the absence of manufacturer’s recommendations.”

- U.S. and D.S. distances required

1D rise is not an absolute requirement for any meter installation under the Delta Voluntary Metering program. But full pipe flow must be obtained.

A 1 pipe dia. Min rise downstream insures full pipe flow.

ORDERING INFORMATION

Please Specify When Ordering Flowmeters for the Delta Voluntary Flowmeter Program. Meter must be on approved list.

Application – agriculture irrigation well flow measurement

Fluid type: Groundwater

Nominal line size*

O.D.: _____

I.D.: _____

Material: _____

Units for indicator

for totalizer: ac-ft

for rate: gpm

Flow rate – maximum: _____

Minimum: _____

Pressure – maximum: 22psi

Minimum: 1 psi

Temperature – maximum operating

(groundwater averages 65 deg F. Air temperature 100 deg F)

Style and model chosen:

Bolt on saddle

Flow Tube

Flange

Weld-in

Other describe: _____

Flow straightener/conditioner (if bolt on) – note these are not straightening vanes:

Yes

No

Position:

Horizontal

Vertical (e.g. center pivot)

Special Constructions and Options:

- **overrun bearings required**

* – On saddle mounted meters, please furnish the inside diameter of the pipe in which the meter will be used. The outside diameter is also necessary on saddle meters and flow tubes.

1. Check available straight line distance available for flowmeter installation.

2. Determine material flowmeter will be installed in.

3. Determine O.D. and I.D. of material.

4. Complete form and submit to supplier for ordering.

If a flow straightener must be installed through flow meter opening (rather than end of pipe), you must specify to get the correct saddle to cover the larger opening.

3.4 PIPE RUN REQUIREMENTS

Flowmeters are velocity sensing devices and are vulnerable to certain upstream disturbances. Because of this, meters need certain lengths of straight pipe runs before and after the meter. These distances usually relate to the diameter of the pipe used. Obstructions can include elbows, valves, pumps, and changes in pipe diameter. The uneven flow created by these obstructions can vary with each system. If your application provides for more than five diameters of upstream run, use the available distance.

- **Upstream Requirement:** Propeller meters should be installed a minimum of five to ten diameters upstream of any obstructions. See the tables below. The exact upstream piping requirements are specific to the meter model number.
- **Downstream Requirement:** The downstream run should be one to two diameters of straight pipe length after the meter.

For upstream and downstream piping requirements relating to your specific meter, contact your local representative. (Please be prepared to provide the serial number of your meter.)

Follow the specific recommendations from the manufacturer whose meter you are installing.

Flow tubes with Flow Straightener requires the least amount of distance, and all required distances are contained in the flow tube length.

Whenever straight length of pipe is minimal for meter installation, a “flow tube” has the best chance of fitting and working.

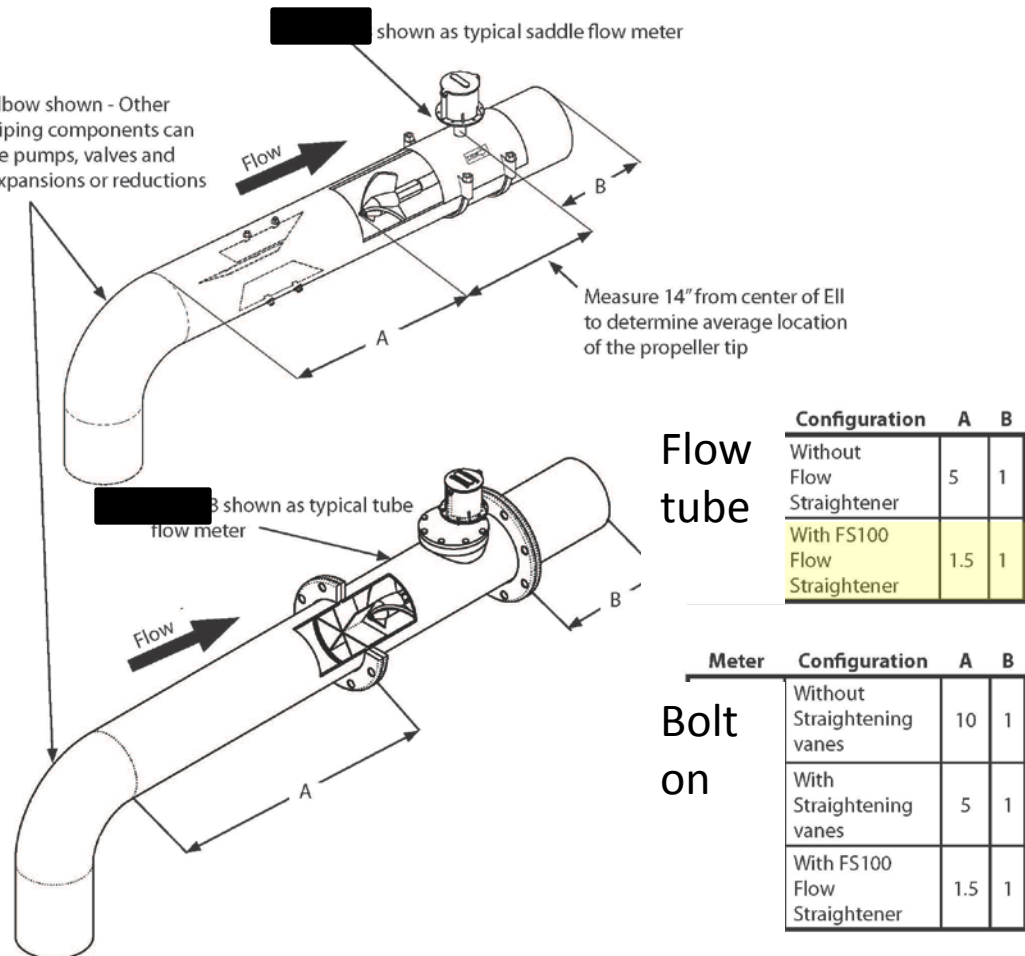

Figure: 5 Pipe Run Requirements For Saddle And Tube Style Flow Meters

M0300F FLOW METER FS100 INSERTION FLOW STRAIGHTENER

DESCRIPTION:

The Mc SpaceSaver System combines our breakthrough flow straightening technology with a self-cleaning Mc Propeller meter design that virtually eliminates the upstream/downstream straight pipe runs. This advanced design delivers highly accurate liquid flow measurement in a rugged space-saving design that reduces installation costs, offers long-life and requires minimal maintenance.

SPECIFICATIONS:

Min. Up Stream

Straight Run: 1.5 pipe diameters minimum (measured from propeller)

Acceptable

Installation Effects: Chemigation Valves
In plane elbows
Out of plane elbows
Fully Open Butterfly and Gate Valves

Sizes: 6" & 8" Nominal and OD pipe.

Customer Pipe wall: Metal $\geq 0.08, < 0.5$
Plastic $\geq 0.25, < 0.5$

For M0300F

Installation: Inserted into pipeline through rectangular hole and locked in place by a single $1/2$ or $5/8$ inch bolt. The M0300F flowmeter is designed to cover the rectangular hole used to install the flow straightener.

For M0300

Installation: Inserted into pipeline through open end of pipeline and locked in place by a single $1/2$ or $5/8$ inch bolt.

Installation Bolt: Stainless steel bolt with dual seal.

Body M0300F: Fabricated 304 stainless steel saddle with stainless steel drop pipe is supplied with: brass bearing housing, stainless steel bearings, polypropylene impeller, magnetic drive, instantaneous flow indicator, straight-reading six-digit totalizer, and flat neoprene gasket.

Body FS100: 304 Stainless Steel.

Exterior: Glass bead blasted.

Pressure Rating: 150 psi max.

Note: if a flow straightener will be installed through the flowmeter opening (rather than through the end of the pipe), a special flowmeter is required to insure the saddle will adequately cover the hole. For this manufacturer a M0300F

M0300F FLOW METER FS100 INSERTION FLOW STRAIGHTENER

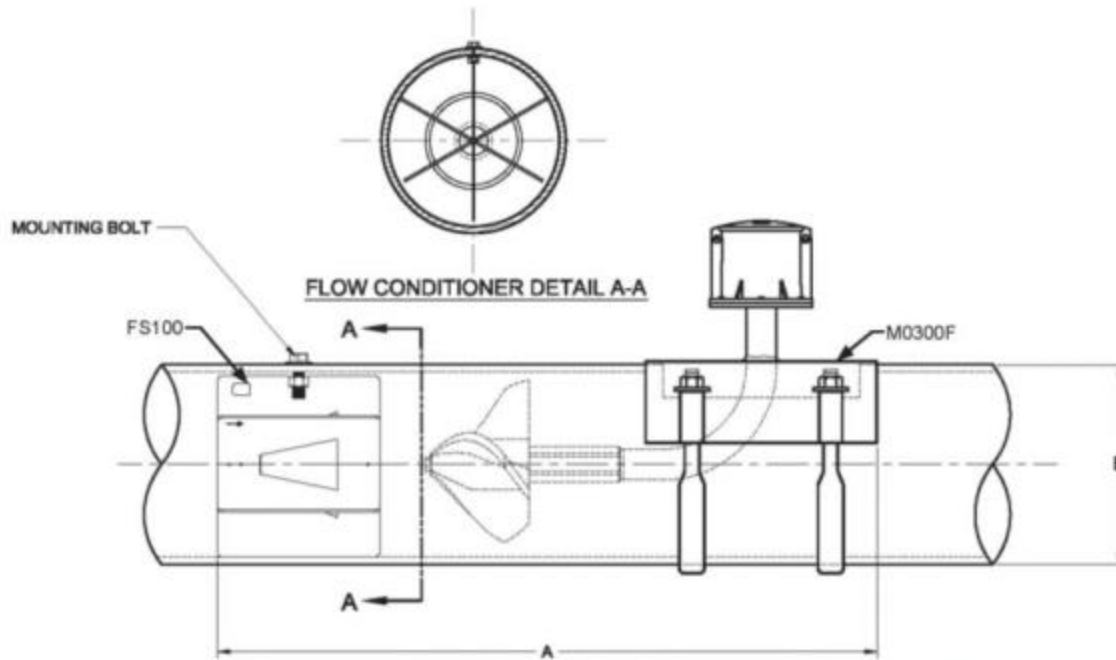

For 10" and larger pipe sizes, a section of pipe may need to be cut out to allow insertion of the flow straightener from the end of the pipe, allowing the use of the normal meter.

Currently, some manufacturers can only provide the larger saddle in 6" and 8" pipe sizes.

	M0300F FLOW METER MODELS							
	M0300F	M0300F	M0300F	M0300F	M0300F	M0300F	M0300F	M0300F
FS100 Model	FS100 FLOW STRAIGHTENER MODELS							
	FS106-1	FS106-2	FS106-3	FS106-4	FS108-1	FS108-2	FS108-3	FS108-4
Pipe OD (B)	6.625	6.625	6.0	6.0	8.625	8.625	8.0	8.0
Wall Thickness Range	0.080	0.200	0.080	0.157	0.080	0.210	0.080	0.162
	to	to	to	to	to	to	to	to
	0.199	0.320	0.156	0.260	0.209	0.340	0.161	0.260
'A' with M03xxF Flowmeter	22	22	22	22	28- $\frac{1}{2}$	28- $\frac{1}{2}$	28- $\frac{1}{2}$	28- $\frac{1}{2}$
'A' with M03xx Flowmeter	26- $\frac{1}{4}$	26- $\frac{1}{4}$	26- $\frac{1}{4}$	26- $\frac{1}{4}$	31- $\frac{1}{4}$	31- $\frac{1}{4}$	31- $\frac{1}{4}$	31- $\frac{1}{4}$
FS100 Shipping Wt. (lbs)	3.3	3.2	3	2.9	5.9	5.7	5.5	5.3
M0300F Shipping Wt. (lbs)	22	22	22	22	26	26	26	26

Notes:

1. Legal Protection Pending.
2. M0300F flowmeter, shown in diagram above, provided separately.
3. Upon request: special pipe diameter and special wall thickness.
4. Select the appropriate M0300 Flow Meter and FS100 Flow Straightener for a complete Mc SpaceSaver system.

Easiest site: open discharge, many options
- no issue meeting installation requirements



03/28/2013

Easier site: existing closed system with sufficient straight pipe length

**-bolt on saddle meter and flow straightener, or
-flow tube**

- key point: I.D. of pipe for ordering bolt-on meter

- 1D rise not required in existing "closed" system

- operator will have to insure full pipe flow

03/28/2013

Hard site:

- marginal room for even a flow tube
- since flow is split at stand no underground line that carries 100% of well flow to install in.





New closed system assuring proper flowmeter installation. Sufficient straight pipe length for U.S. and D.S. distances.

Locate placement for correct U.S. and D.S. distances





INSTALLATION INSTRUCTIONS FOR BOLT-IN VANES

I. Installation Procedures

1. Determine the locations of the vanes on the outside of the pipe. For use with bolt-on saddle meters, the distance (A) between the trailing edge of the vane and the centerline of the hole-cutout is indicated on the table below. Vanes must be parallel to the center line of the pipe and should be equally spaced radially 120° apart.

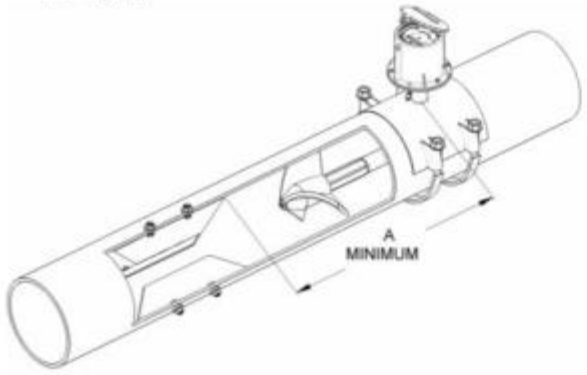

SADDLE METER SIZE	"A" DIMENSION
4"	6-5/8"
6"-16"	14"
18"-38"	16"
42"-60"	20-3/8"

2. Establish the centerline of the pipe by using a centering tool.
3. Mark the pipe where the vane bolts will protrude from the line.
4. Drill holes as required in the pipe to allow the bolts from the vanes to protrude. The hole diameters are 7/16" for 4" through 14" meters and 9/16" for 16" through 36" meters.



5. Insert the vanes into the pipe through the saddle cutout, and hold vanes in position with the bolts protruding through holes.

6. Secure the vanes with the nuts and washer supplied with the vanes. Position the vanes inside the pipe with the bolts protruding through the vane mounting bolt holes. Place sealing rubber washers over each bolt against the outside of the pipe. Then place the stainless washer and the vane mounting nut. Secure nuts to hold the vanes to the pipe (approx. 60ft./lbs torque). The vanes can be welded to the pipe if desired, however the washer should not be used.

CAUTION: Remove the meter assembly before welding.

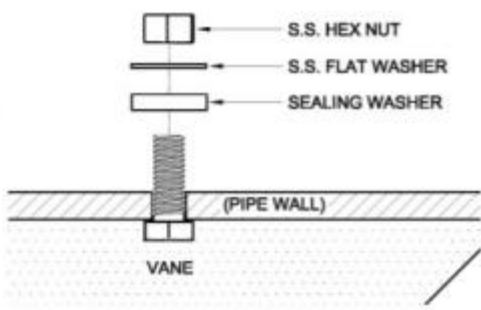

For bolt in vanes follow the specific recommended manufacturer procedure and distances.

Straightening Vanes are not the same as a Flow Straightener.

A Flow Straightener minimizes the required U.S. distance.

FS100 Installation For The M0300\M0300F Flowmeter

See the template supplied with the M0300F for flowmeter installation instructions.

1. Relieve the pressure and drain the line prior to installation. Determine the location of the FS100 on the outside of the pipe. The distance (A) between the bolt hole and the centerline of the ell is indicated on the table below. The centerline of the FS100 must be parallel to the centerline of the pipe.

METER SIZE	A	B	C
6"	20 5/8	2 5/8	17/32
8"	22 3/4	3 1/2	17/32

2. Establish the centerline of the pipe by a centering tool. Mark the pipe for the bolt location (see B dimension in the table above).



3. Drill a hole (see C dimension in the table). Break line at a flange or cut pipe in a portion near the installation location of the FS100.

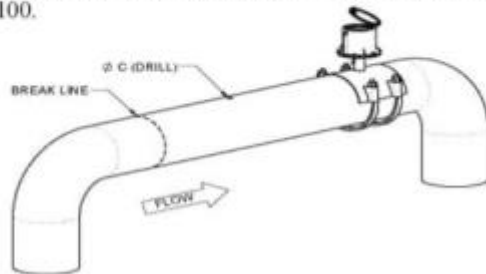

5. Secure the FS100 with the bolt, washer and o-ring supplied with the FS100. Place sealing rubber washer and the o-ring under bolt against the outside of the pipe. Secure the bolt to hold the FS100 to the pipe. Apply Loctite® anti-seize C5-A, or other appropriate lubricant, to the bolt prior to installation to ensure the bolt and nut do not seize up prior to creating an effective seal.

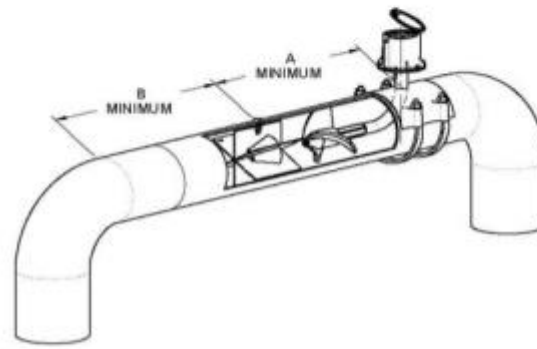
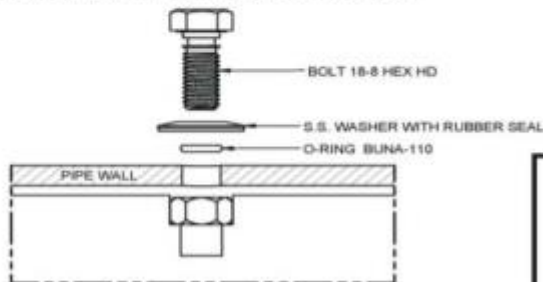

4. Insert the FS100 into the pipe.

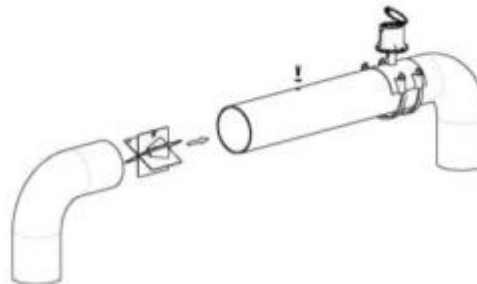

6. Close the line at the flange or repair the break.

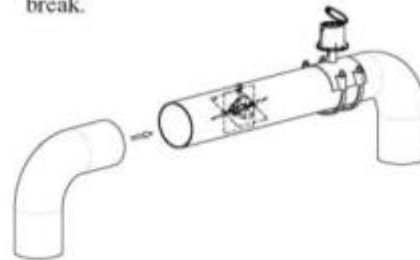

NOTE: It is advised the installer not use air guns or impact wrenches to tighten the bolt as it may damage the FS100 flowstraightener.

For bolt in Flow straightener, follow the specific recommended manufacturer procedure and distances.

Use of a flow straightener minimizes the U.S. distance requirement.

It is preferable to insert the Flow Straightener through the open end of pipe section.

Installation in existing “closed” system when insufficient distance exists between pump discharge and stand/dogleg.

Place in existing buried line that still carries 100% of well flow

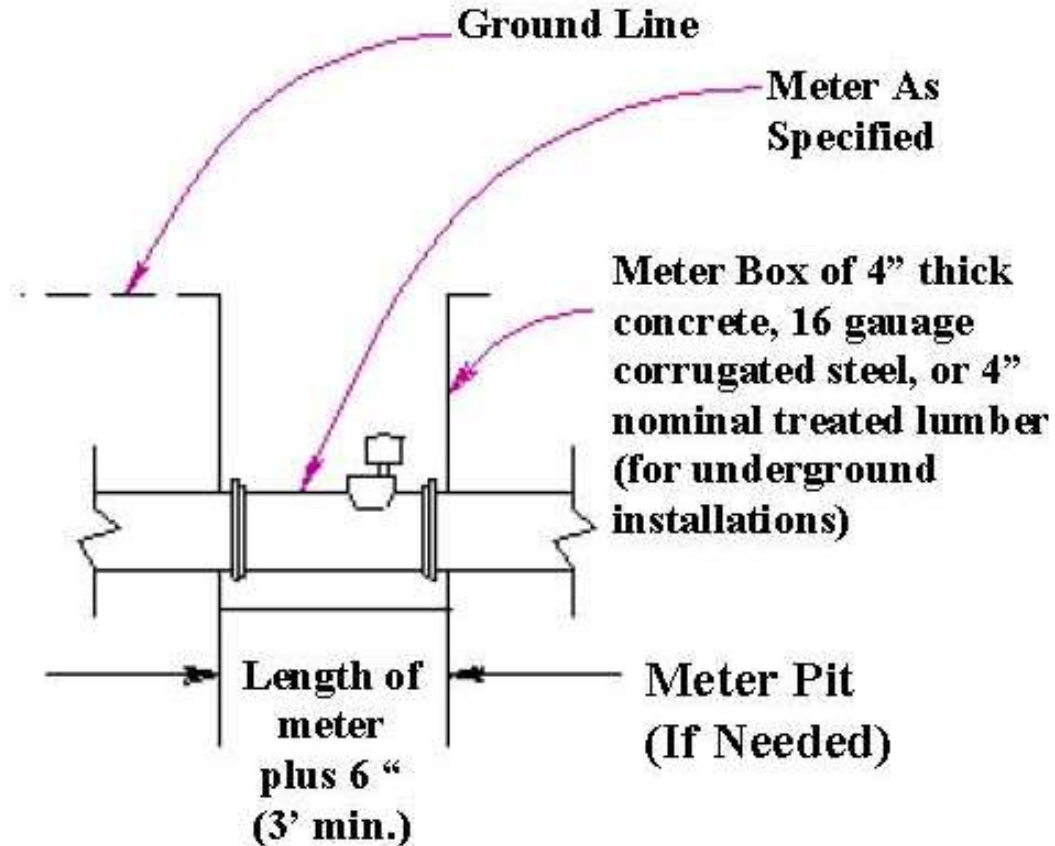

- Pits should be sloped back on 3:1 on sides for safety and access.
- Register should be on extension to within 6" of meter box top.
The register is not to be submerged.
- Alternative meter box installations can be accepted . (e.g. CPP)
- Do not fill meter box with gravel or other material.

Line must be carrying 100% of well flow 100% of time!



Step 1: Access Underground Line

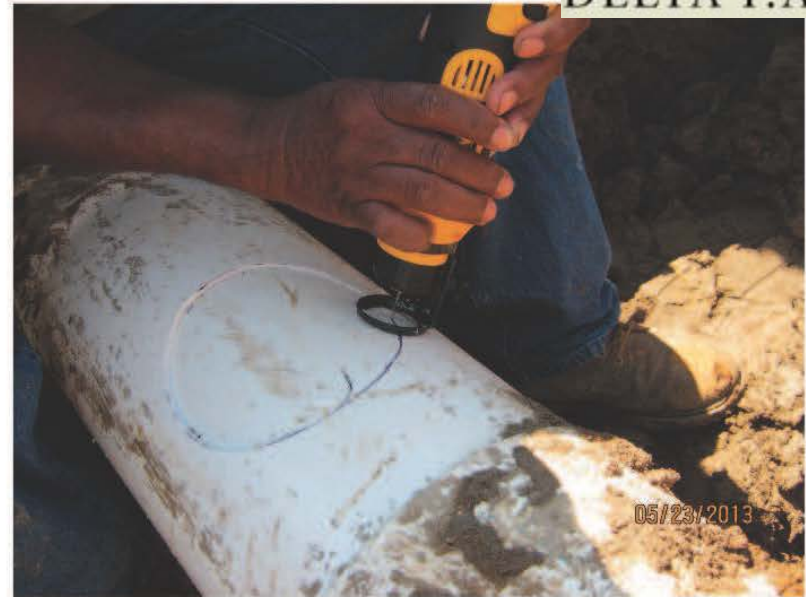

Step 2: Cut Appropriate Size Hole -continued



Step 2: Cut Appropriate Size Hole (See instalation specs)



Step 2: Cut Appropriate Size Hole -continued

Order meter with a register extension to bring above surface!



Step 3: Clean and check hole size



Step 4: Install Meter - continued



Step 4: Install Meter



Step 4: Install Meter - continued



Do not backfill meter box, so meter can be accessed in future easily.



Meter on register extension and meter box should rise above soil surface so that the register is not submerged.



Dial Face with Gallon Totalizer x 100
Add 2 zeros to the 6-digit dial face reading.
Total Gallons = 89,057,200



Dial Face with Gallon Totalizer x 100
Add 2 zeros to the 6-digit dial face reading.
Total Gallons = 41,012,800



Dial Face with 3 fixed zeros.
Include these zeros in your reading.
Total Gallons = 113,509,000



Dial Face with Acre Feet Totalizer x .001
and GPM Flow Rate Indicator. Place a
Decimal Point 3 places to the left.
Acre Feet = 974.602



Dial Face with Acre Inches Totalizer x .01
and GPM Flow Rate Indicator. Place a
Decimal Point 2 places to the left.
Acre Inches = 160.53



Dial Face with Cubic Feet Per Second
flow rate and Acre Feet Totalizer. Place
a Decimal Point 3 places to the left.
Acre Feet = 278.760

© 2011 by McCrometer/Printed in USA

PROPRIETARY AND CONFIDENTIAL
THIS DOCUMENT CONTAINS
PROPRIETARY INFORMATION AND MAY
NOT BE DISCLOSED TO OTHERS FOR ANY
PURPOSE, NOR USED FOR
MANUFACTURING PURPOSES WITHOUT
WRITTEN PERMISSION FROM
MCCROMETER GREAT PLAINS.

115 S. 16th st. Aurora, NE 68818 USA
(402) 694-4114 • Fax (402) 694-0688
Website: www.greatplainsmeter.com

DRAWING TITLE

**READING AND
UNDERSTANDING
DIAL FACES**

	NAME	DATE
DRAWN BY	JT	10-10-2011
APPROVED BY	KE	11-29-2011
REVISED BY	-	-
FILE NAME:	READING DIAL FACES	



McCrometer
GREAT PLAINS

REV. - DRAWING NOT TO SCALE SHEET 1 OF 1

Summary: Flowmeter installation for Delta Voluntary metering Program

Installation:

- 1) Pipe upstream and downstream lengths must be sufficient, measure, check.
- 2) Pipe I.D. and O.D. must be measured correctly
- 3) Meter must be ordered for correct pipe sizes (note: this is step 3)
- 4) Order a flow straightener if U.S. distances is insufficient
- 5) Surest installation is to order a “flow tube” to fit into your pipeline
- 6) Order meter from supplier with all information above.
- 7) Install to the manufacturer’s recommendations.
- 6) Regulate flow to create enough back pressure to cause full pipe flow at the meter
(e.g. air vent closed)

QUESTIONS

1) Question: would a discharge going into a manifold (e.g. dogleg/stand) cause enough backpressure to make pipe flow full?

Answer: it may or may not, always check the air vent to see that it is closed.

2) If the “sweat” line on a stand (e.g. manifold) was above the flowmeter, would that mean the pipe is full?

Answer: the sweat line does represent the approximate water level, so if the line is 2-3 inches above the flowmeter, the pipe should be full.

3) If a check valve causes a “jetting” condition, should the check valve be moved downstream of the meter when installing the meter?

Answer: MDEQ oversees check valves on wells so they would have to clear moving it, but from the physical standpoint, being downstream of the flowmeter would eliminate the jetting concern.

4) If I have a system without a check valve, and install a flowmeter, do I also have to install a check valve.

Answer: MDEQ would have to answer that question.