



SINCE 1908
wessels
 company

SUBMITTAL

WVAD-HV (High Velocity) -SERIES
 DIRT SEPARATOR

Models: WVAD-2HV thru WVAD-12HV

Submittal Sheet No. D-1018A

Date: 9/16

Job Name _____	Submitted By _____	Date _____
Location _____	Approved By _____	Date _____
_____	Order No. _____	Date _____
Engineer _____	Notes _____	
Contractor _____	_____	
Sales Rep. _____	_____	

Description

Wessels WVAD-HV (High Velocity) series Dirt Separators are designed to separate debris associated with start-up and maintenance of any hydronic system. The design incorporates a skim valve for eliminating floating debris, removable end cover for coalescing medium access, and an air vent to automatically release air from the separator.

Construction

Shell: Carbon Steel
 Coalescing Medium: Stainless Steel
 Blow Down Valve (optional): Brass
 Skim Valve (optional): Brass
 Vent (optional): Cast Iron

Performance Limitations

Maximum Design Temperature: 250°F
 Maximum Design Pressure: 150 PSIG*

*125, 200 & 250 PSIG available

Model Number	Part Number	Max Flow (GPM)	Tagging Information	Quantity
WVAD-2HV	72307002	105		
WVAD-2HV-NPT	72307014	105		
WVAD-2.5HV	72307038	155		
WVAD-2.5HV-NPT	72307050	155		
WVAD-3HV	72307074	225		
WVAD-3HV-NPT	72307086	225		
WVAD-4HV	72307110	405		
WVAD-5HV	72307146	630		
WVAD-6HV	72307170	910		
WVAD-8HV	72307194	1610		
WVAD-10HV	72307218	2450		
WVAD-12HV	72307242	3500		

Typical Specification

Furnish and install, as shown on plans, a WVAD-_____HV Dirt Separator as manufactured by Wessels Company. Each separator must be designed with a blow down valve, skim valve, and automatic air vent. The separator must also utilize in its design a stainless steel coalescing medium to aid in the separation of air and dirt in the system's entrained water. The separator must be constructed in accordance with the most recent addendum of Section VIII Division 1 of the ASME Boiler and Pressure Vessel Code and shall be constructed and stamped for 150 PSI working pressure @ 250°F.

Each air separator shall be Wessels model number WVAD-_____HV or approved equal.

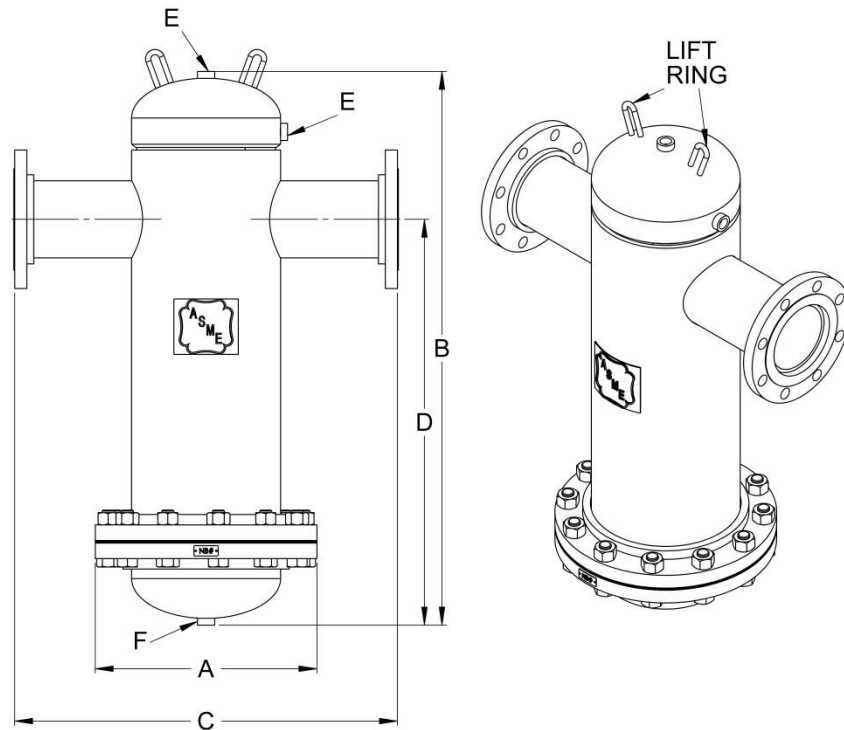

WVAD-2HV thru WVAD-12HV

Dimensions & Weights

Model Number	Dimensions in Inches							Approx Shipping Wt (lbs)				
	Connection Size	A	B	C	D	E	F					
WVAD-2HV	2	9	23	15 1/4	16 1/2	1/2	1/2	69				
WVAD-2HV-NPT				10 3/8				60				
WVAD-2.5HV	2.5	10		15 3/4				89				
WVAD-2.5HV-NPT				11				77				
WVAD-3HV	3	11	30	20 1/4	21			1/2	1/2	125		
WVAD-3HV-NPT				12 1/2						110		
WVAD-4HV	4	13 1/2		20 5/8						185		
WVAD-5HV	5	16	41	27 3/4	29 1/2					1/2	1/2	280
WVAD-6HV	6	19										390
WVAD-8HV	8	23 1/2	49	33 5/8	37 3/4							1
WVAD-10HV	10	27 1/2	60	37 1/2	46	744						
WVAD-12HV	12	32	71	42 1/2	55	1169						

Notes

- Trim package is optional.