

ENVIRONMENTAL HEALTH EMERGENCY RESPONSE PLAN



Environmental Health Section

Update, February 2014

TABLE OF CONTENTS

INTRODUCTION.....	1
ENVIRONMENTAL RESPONSE PLANNING.....	3
ENVIRONMENTAL HEALTH SERVICES.....	4
DISTRICT PLANS	5
PRIORITIES.....	6
PREPAREDNESS	7
MASS FEEDING FACILITIES STANDARD OPERATING PROCEDURES.....	8
Environmental Health Inspection Report Emergency Food Service.....	9
Emergency Food Service Notes.....	10
Environmental Health Mass Feeding Sites Log	11
EMERGENCY HOUSING FACILITIES STANDARD OPERATING PROCEDURES.....	12
Environmental Health Inspection Report (Pre-Inspection/Post-Inspection) Emergency Housing Facilities	13
Emergency Housing Facilities Notes	14
ENVIRONMENTAL HEALTH EMERGENCY HOUSING SITES LOG	15
WATER SUPPLIES	16
INDIVIDUAL WATER SUPPLIES EMERGENCY TREATMENT.....	17
EMERGENCY WATER SUPPLIES STANDARD OPERATING PROCEDURES	18
Environmental Health Inspection Report Bulk Transported Water	19
INDIVIDUAL WATER SUPPLY SYSTEMS (WELLS) STANDARD OPERATING PROCEDURES	20
WELL CHLORINATION INSTRUCTIONS.....	21
Water Well Evaluation Report Form	22
COLLECTING WATER SAMPLES STANDARD OPERATING PROCEDURES.....	277
WATER SAMPLE LOG INSTRUCTIONS	28
Environmental Health Water Sample Log	29
REGULATED FACILITIES STANDARD OPERATING PROCEDURES WATER INTERRUPTION	30
OUTDOOR SEWAGE SPILL GUIDANCE	35
NON-SEWERED TOILET STANDARD OPERATING PROCEDURES.....	37
ENVIRONMENTAL HEALTH INSPECTION REPORT NON-SEWERED TOILETS.....	39
Environmental Health Inspection Log Non-Sewered Toilet Site Locations	40
SOLID WASTE MANAGEMENT STANDARD OPERATING PROCEDURES	41
Environmental Health Inspection Report Solid Waste	42
COMPLAINT \ INCIDENT REPORT INSTRUCTIONS	43
Environmental Health Complaint/Incident Report	44
COMPLAINT\INCIDENT LOG INSTRUCTIONS.....	45
Environmental Health Complaint/Incident Log	46

HAZARDOUS MATERIALS	47
Environmental Health Inspection Report Hazardous Materials Inventory	49
Hazardous Materials Notes.....	50
RADIOLOGICAL RESPONSE	51
INSECT AND RODENT CONTROL STANDARD OPERATING PROCEDURES.....	54
Insect and Rodent Control Notes.....	55
ENVIRONMENTAL HEALTH RABIES CONTROL PROGRAM CURRENT STATUS	56
Rabies Control Notes	57
SWIMMING POOLS STANDARD OPERATING PROCEDURES	58
Environmental Health Inspection Report Swimming Pools/Recreational Waters	59
Swimming Pools/Recreational Waters Notes	60
Environmental Health Inspection Report Daily Activities (Situation Report).....	61
COMMUNICATIONS LOG INSTRUCTIONS	62
Environmental Health Communications Log.....	63
RESOURCES FILE.....	64
RESOURCES FILE ITEMS.....	65
Resource File Instructions.....	67
Environmental Health Resources Log.....	68
CONTACTS FILE	69
Contact File Instructions.....	71
Environmental Health Contacts Log.....	72
DIRECTORY FILE	73
Environmental Health Directory Log	74
MEDIA CONTACTS.....	75
Environmental Health Media Directory.....	76
PUBLIC SERVICE ANNOUCEMENTS EXAMPLES	77
FOOD SUPPLIES	78
PRESCRIPTION MEDICATIONS	79
STAY OUT OF FLOOD WATERS	80
CONTROL RATS AFTER FLOOD	81
AVOID HAZARDS FROM GAS, ELECTRICITY	82
MOSQUITO CONTROL AFTER FLOOD	83
NO SHOTS NECESSARY FOR FLOOD VICTIMS	84
FLOOD CLEANUP: AVOID INFECTION	85
BE SURE YOUR WATER IS SAFE TO DRINK	86
SAFETY HAZARDS	87
FIELD SAFETY.....	88
RECOVERY \ MITIGATION.....	92

OUTDOOR AIR QUALITY	93
EDUCATION SECTION	94
Hand Washing Signs.....	94
Food and Water Safety.....	95
General Health Guidance for Flood Hazards	98
Minimum Number of Portable Sanitation Units at Construction Sites	103
Mosquito Surveillance Trailer	105
Environmental Assessment Guide	107

RECORD OF CHANGE

CHANGE NUMBER	DATE OF CHANGE	DATE ENTERED	CHANGE MADE BY (SIGNATURE)

INTRODUCTION

This Environmental Health Disaster Response Plan is an annex to the Department of Public Health Emergency Response Plan. It is designed for use by local health departments and can easily be adapted to meet the needs that arise due to any disaster. It will assist you in identifying potential problems and available resources, and will facilitate an organized response and efficient use of resources. The purpose of this plan is to ensure that environmental hazards to public health and the environment, such as contaminated media, epizootic disease, and environmental health infrastructure failure, are managed.

It is recognized that every emergency is different requiring employees to be flexible, open minded, and innovative. Many of the activities described below are applicable regardless of the cause of the emergency and can be site adapted to meet the needs of the victims.

This plan will be implemented at the direction of the District Health Officer or his designee, based on an assumption of authority policy established at the time the plan is adopted. This plan replaces and supersedes any plan published prior to the date on the cover page.

If there is advanced warning of an impending catastrophe the staff should be notified immediately and every effort should be made to assist them in assuring the safety of their families and the protection of their property. They will, however, be expected to comply with the plan and report to their duty stations at the time scheduled.

In *Webster's Ninth New Collegiate Dictionary*, **emergency** is defined as "an unforeseen combination of circumstances or the resulting state that calls for immediate action" or "an urgent need for assistance or relief".

Emergencies can be categorized according to size, type, or cause. All require an immediate, organized, effective response. Natural disasters are usually large in size and affect many people and large geographical areas. These include hurricanes, floods, tornadoes, ice storms, forest fires, and earthquakes. Manmade disasters are usually localized in nature but can also include large numbers of victims with severe or fatal injuries. They include train wrecks, industrial fires, chemical spills, airplane crashes and intentional disasters such as terrorist events, arson, mob violence, or acts of war.

Responsibilities under ESF-8

The Health Department is responsible for providing public health services necessary to prevent or control diseases in the community related to the emergency and to assure the best quality of life possible until the emergency is over and normal conditions have returned. Environmental Health responsibilities include sanitation services such as food and water supply safety, insect and rodent control, facility/shelter inspections, and developing and monitoring health information. Nursing services include staffing emergency shelters, first aid, children's medical service, and AIDS clinics. Laboratory services include testing water samples, diagnostic tests, and coordination with other labs for specialized testing. Administrative activities will support all functions and provide necessary supplies and equipment to meet the Department's responsibilities.

The following chart lists the situations most likely to occur in your district along with Health Department responsibilities.

DISASTER	PROBLEMS	PRIMARY RESPONSIBILITIES	SUPPORT RESPONSIBILITIES
HURRICANE	Damaged or destroyed housing, contaminated or inoperable water systems, failure of sewage disposal systems, power failure, trauma from flying debris, shortage of medical supplies, mass feeding sites, animal bites, lack of refrigeration, communications	Assure safety of water and food supplies, safe mass shelter facilities, proper sewage disposal, rabies control, insect and rodent control, hazardous materials exposure, provide public information on food safety, safe re-entry into facilities	Assist in relocation of special needs population, EMS services, support other responding agencies such as Red Cross, Salvation Army, DNR, Agriculture Department, DFCS
TORNADO	Damaged or destroyed housing, trauma, electrical failure, water and sewer system failure, hazardous materials exposure, mass feeding sites, lack of refrigeration, communications	Prevention of further injuries, safety of water and food supplies, safe shelter for victims	Assist in shelter operations, EMS services, support other agencies, DNR, Red Cross, Salvation Army, DFCS, city and county governments
FLOOD	Displaced persons, housing destroyed, electrical failure, contaminated wells and water systems, failure of sewage systems, animal bites, solid waste disposal, insect and rodent control, mold and mildew in homes, trauma during cleanup, communications	Assure safe shelters, safe food at mass feeding sites, safe water, rabies control, emergency sewage disposal facilities, insect and rodent control, disease surveillance	Support agencies providing shelter, food and social services, assist in evaluating damages and planning mitigation efforts
WINTER STORMS	Power failure, lack of heat, failure of medical support equipment, failure of water and sewer systems, communications failure, food shortage due to transportation difficulties, trauma during cleanup, medical transportation failure, communications	Assure safety of shelters, water supplies, sewage disposal, public information on heating safety, public information on injury prevention, EMS services	Support agencies supplying food, shelter, blankets, medical help, and social services, assist EMA in evaluating needs and organizing response
TRANSPORTATION INCIDENT	Hazardous/ Radiological materials exposure, trauma to passengers of vehicle or plane, large number of fatalities, overload of EMS capabilities, local evacuations, communications failure, injury or exposure of responders, communications	Public information on dangers of exposure, safety of water supply, safe shelters, safe food	Support other agencies as requested
INDUSTRIAL INCIDENT	Hazardous / Radiological materials exposure, trauma to employees and responders, local evacuations, shelters, mass feeding sites, overload of medical services, communications	Public information on dangers of exposures, safety of shelters and food supplies, location of additional EMS providers, identification of victims and tracking of victims	Assist EMA and other responders in identifying needs and locating resources
HEAT EMERGENCY	Increased demand on medical facilities and EMS, possible failure of medical equipment due to power failure, increased violence, communications	Public information on heat related illnesses, shelter safety, food safety, identification of special needs population	Assist EMA and other responders in identifying needs and locating resources
ENERGY EMERGENCY	Exposure to extreme temperatures both hot and cold, failure of medical equipment for special needs population, communications failure, water and sewer systems failure, dietary problems due to inability to cook and lack of refrigeration, fuel shortage, communications	Safe water and food supplies, safe shelters, public information on safety during emergency, identification of needs and resources	Support other responding agencies as requested
TERRORISM	Damaged or destroyed housing, displaced persons, trauma, electrical failure, water and sewer system failure, hazardous/radiological materials exposure, mass feeding sites, lack of refrigeration, communication failures, hazardous materials exposure, large number of fatalities, overload of EMS capabilities, local evacuations, communications failure, injury or exposure of responders	Public information on dangers of exposures, safety of shelters and food supplies, location of additional EMS providers, identification of victims and tracking of victims	Support agencies supplying food, shelter, blankets, medical help, and social services, assist EMA in evaluating needs and organizing response
RADIOLOGICAL	Radiological release exposure, contamination of people, livestock, trauma to employees and responders	Public Information on dangers of exposures, population monitoring, staffing Community Reception Centers	Assist in population monitoring with public health rad equipment, support other agencies as requested

ENVIRONMENTAL RESPONSE PLANNING

The ability to effectively meet the needs of the people in your county or district in the aftermath of a major disaster is dependent upon the quality of planning done prior to the event.

In order to prepare a plan that will enable the Health Department to function in a manner that fulfills its obligation to protect the health of the victims and the people that have come to assist in the recovery effort all facets of public health must be considered. Although this document is prepared for Environmental Health functions the same process can and should be applied to other programs in the Health Department since disaster response requires a team effort to be successful.

Immediately after a disaster, the focus of activities shifts from those activities that meet long term results such as chronic disease control and family planning, to those that meet an immediate need such as safe food and water, shelter from the elements, prevention of epidemic types of communicable diseases, maintenance of ongoing medical treatment, insect and rodent control and solid waste management.

Your Emergency Response Plan should anticipate the types of disasters most likely to occur in your area, the types of damages they would produce, the impact upon the residents, and the resources required to meet their needs. Much of your planning will be applicable to more than one type of event. For example, both hurricanes and ice storms produce power outages over large geographical areas and call for similar response activities.

Activities that we have become accustomed to and consider routine suddenly become a major challenge. Among these are maintaining safe food supplies and food service operations, water supplies, insect and vector control, sewage disposal, and rabies control. You must determine which activities are most important, predict the constraints imposed by the disaster, determine the appropriate response, identify the resources needed, and locate a source that can supply these resources quickly or stockpile them before the disaster occurs.

In the following pages you will find suggested protocols, policies, and activities along with the forms that can be used to record actions and manage your response. They provide you with a starting block upon which you can build an emergency response plan that is realistic and allow your agency to respond in an effective manner. Every disaster and every county and district are different so you probably will need to add information that is specific for your area.

Do not feel that you are gathering a large amount of information that may never be used. It will not only teach you a great deal about your area and establish communications with other agencies it will also be invaluable in time of a disaster. After a disaster occurs you will not have time to assemble the information needed to initiate a successful response.

ENVIRONMENTAL HEALTH SERVICES

Five levels of Environmental Health Specialists (EHS) provide Environmental Health services in Georgia. Their position classifications vary according to levels of supervisory responsibility and programmatic activities.

EHS are employees of the 159 county Boards of Health and are supervised by the District Environmental Health Directors who are GDPH employees that report to the District Health Directors.

There are eighteen (18) Health Districts in the state, with each having an Environmental Health District Director. The State Environmental Health Section provides programmatic support and consultative services to the district and local staffs. See organization chart below.

EHS = Environmental Health Specialist

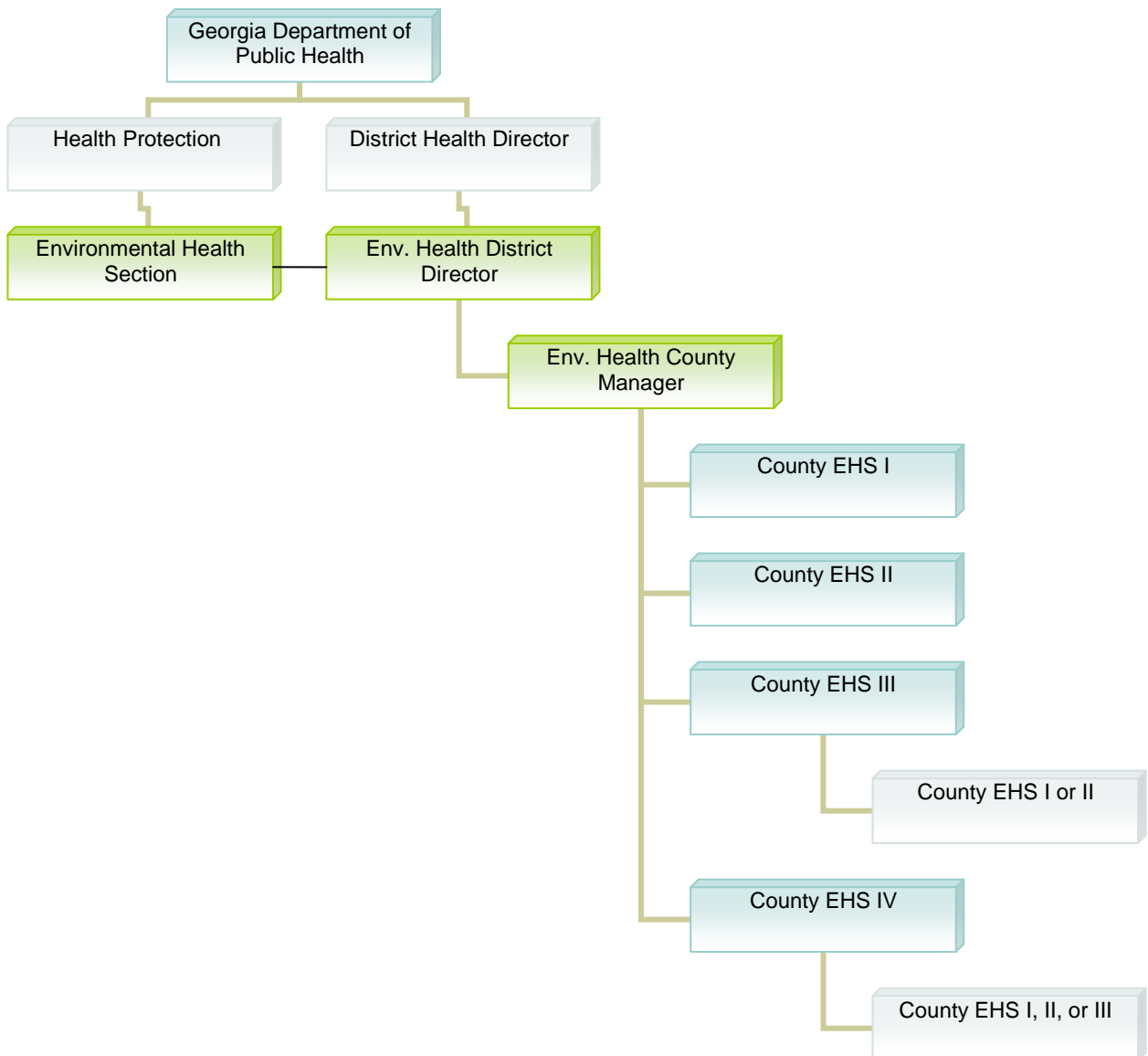

DISTRICT PLANS

All **District Plans** should have copies of the plans for all counties within the district as annexes, both hard copies and computer disks.

The **District Plan** should address assessment of situation, coordination of personnel and resources on a larger scale than the county plans (within the district, adjoining districts, and statewide). It should contain information on how to contact all supervisory staff within the district at any time, including times of evacuation. A telephone number of a person that will be able to contact the employee in times of emergency should be included.

The "Contacts File, Resources File, and Directory" should include local environmental health staff in the district, county supervisors in the district, district supervisors, district staff of all districts, DPH staff, DFCS county directors & district supervisors, DNR regional managers, regional and state Red Cross, Salvation Army contacts, Agriculture Department regional supervisors & state staff, DOT district engineers, regional EMS coordinators, county sheriffs for all counties in district, commanders of all State Patrol Posts in district, chairmen of all county commissions in the district, mayors of all towns & cities in the district, fire chiefs and police chiefs for all departments in the districts and any other people that might be able to help in response activities.

The **District Plan** should provide for the availability of all supplies and equipment to adequately respond to a disaster in one county or multiple counties in the district. This would include copies of all protocols, policies and procedures to be used along with the necessary forms and equipment to carry them out and record their completion.

A procedure of reporting needs, resources, actions and accomplishments is vital if the emergency involves more than one county. A form for consolidating this information and reporting to the state offices is necessary.

An annual review and update of the plan is an absolute must for it to be kept current and effective.

Copies of the **District Plan** should be kept in the District Office and in the District Environmentalist's vehicle. The District Environmentalist should require that each county's plan be available in each county office and in the Environmentalist's vehicles.

PRIORITIES

In order to best utilize the resources available in responding to a disaster one must evaluate the situation and establish an order of actions to be taken. In other words, you must prioritize what you are going to do.

This order of action is dictated by the situation at the time your agency becomes active in its response role. For example, your actions would be quite different in responding after an earthquake than in preparing for an impending hurricane or flood. A planned, proactive public information program using all forms of the media is necessary for your response to be effective in all stages.

Regardless of the type of disaster or time of action, most agencies organize their efforts along the following lines.

1. The most important actions are those which will remove people from immediate danger or lessen their likelihood of injury. Examples: evacuation, sheltering
2. Once an event has occurred, actions directed at removing people from further danger, initial treatment of injuries, and meeting the critical needs of food, water, and safe shelter become the focus of the response efforts.
3. Soon after the victim's basic needs are met the initial response activities begin to change into those of recovery. They address the problem of reducing health hazards by surveillance to detect changing disease patterns, monitoring water and food supplies for safety, provision of sanitary facilities, medical supplies, and insect and rodent control.
4. Recovery activities move toward re-establishing more normal living conditions by addressing long-term housing, health education, and tracking victims to determine long-term effects of the event.
5. As the impact of the event decreases the efforts move into the mitigation phase of emergency response by seeking ways to reduce suffering and losses in future events. This is done by evaluating actions taken, modifying the plan to address unmet needs, providing information and training to residents of the area, and working with other agencies to improve awareness and strengthen regulatory programs.



PREPAREDNESS

Preparedness involves the development of an Emergency Response Plan that enables the programs, activities, and systems existing prior to the threat or occurrence of a disaster to be used to support or enhance the response to the emergency. It also includes the implementation of the sections of the plan calling for memorandums of understanding, contracts, and mutual aid agreements with other agencies and organizations both public and private.

The items listed below are critical components of an effective plan.

- Identification of potential disasters.
- Determination of Departmental responsibilities.
- Actions necessary to meet Departmental responsibilities.
- Identification of potential needs.
- Identification of resources to meet needs.
- Procurement of M O U's to insure availability of resources.
- Directory of local resources by item, agencies, individual, and expertise.
- Accurate record keeping system to manage response and determine cost of response for possible reimbursement.
- Procedure for de-briefing, evaluation, and after action report.
- Policy to assure regular review and revision of the plan.

MASS FEEDING FACILITIES STANDARD OPERATING PROCEDURES

1. Contact local Emergency Management Agency, Red Cross, city governments, churches, and the Salvation Army to identify locations of potential mass feeding sites.
2. Make an inspection of the facility, accompanied by a representative of the agency that will operate it if possible.
3. Identify the source of water for the mass feeding site and collect a sample if it is not an approved public water system or water system approved by DPH under DNR MOU. A secondary source should be identified for use in case the primary source is no longer useable due to contamination or loss of power. If an on- site well is used, an alternate source of electricity needs to be found and assigned for use by the site. Identify the type of sewage disposal serving the facility and record on the inspection form. An alternate method of wastewater disposal should be considered for use in case the primary one no longer functions due to power loss or treatment plant failure. If the use of non-sewered toilets is an option, estimate the number required and enter it on the form.
4. Make recommendations to agency representative; record them on the form, along with site information such as address, telephone number, agency name and contact person.
5. Create a log of feeding sites using the information collected above.
6. Develop operational information that addresses food safety hazards during emergency situations to be given to operators detailing safe food service methods, menu restrictions, cleaning and sanitizing requirements and methods, temperature control, personal hygiene, solid waste management, and insect and rodent control. These materials should cover food operations from source of food through preparation, cooking, transportation, service, disposing of waste, and cleaning and sanitizing of equipment.
7. Mass feeding sites shall be inspected at least once each day with follow up inspections made as needed to obtain corrections of violations. Operational deficiencies will be discussed with the person in charge of the site at the time of the inspection detailing the problem and giving corrective actions to be taken. Enter information on inspection form.
8. In the event of a food borne out break a joint investigation will be performed by the County EH and the District Epidemiologist. Please see the Environmental Assessment Guide in the Education Section (pg. 107) as well as the Food and Water Related Illness Complaint Form (pg. 114) in the back of this manual.

**Environmental Health Inspection Report
Emergency Food Service**

Health District: _____ **County:** _____ **Date:** _____

Facility Name: _____ **Agency:** _____

Street Address: _____ **City:** _____ **Zip Code:** _____

Contact Person _____ **Telephone:** _____

Type of Facility: Shelter Feeding Site Kitchen

Number of meals daily: Prepared _____ Served _____

Source of meals if not prepared on site: _____

Water Supply: Type: Public Water Transported Private Well
Quality: Acceptable Unacceptable Unknown
Sampled: Yes No Unknown Date sampled _____

Sewage Disposal Type: Public Septic Tank Non-Sewered Toilet Other
Functioning: Yes No
Serviced/Clean: Yes No Service Company Contact: _____

Food Storage: Acceptable Unacceptable
Corrections/Comments _____

Food Preparation: Acceptable Unacceptable
Corrections/Comments _____

Food Temperatures (list additional locations on back): **Cold** $\leq 41^{\circ}$, **Hot** $\geq 135^{\circ}$

Location	Food	Hot	Cold
_____	_____	_____	_____
_____	_____	_____	_____

Equipment-Utensils: Clean/Sanitized Dirty Bad Repair
Corrections/Comments _____

Hand Washing Facilities: Acceptable Unacceptable
Corrections/Comments _____

Trash/Garbage Handling: Acceptable Unacceptable
Corrections/Comments _____

Insect & Rodent Control: Acceptable Unacceptable
Corrections/Comments _____

Orders/Instructions Given _____

Discussed With: _____ Inspected by: _____

Emergency Food Service Notes

Health District:

County:

Date:

**Environmental Health
Mass Feeding Sites Log**

District:

County:

<i>Date Opened</i>	<i>Location Name and Address</i>	<i>Operator Name of Agency Local Address</i>	<i>Telephone # Operator Headquarters</i>	<i>Water Supply</i>	<i>Sewage Disposal</i>
<i>Date Closed</i>		<i>Contact Person</i>	<i>Local Manager</i>		

EMERGENCY HOUSING FACILITIES STANDARD OPERATING PROCEDURES

1. Locations are to be identified in collaboration with the following local agencies: American Red Cross chapter, the Department of Human Services, Division of Family and Children Services and the local Emergency Management Agency. Shelters should be inspected by environmental health personnel in conjunction with representatives of those agencies to evaluate its fitness for use as a shelter. During the evaluation, items such as space, water supply, sanitary facilities, sewage disposal, lighting, ventilation, heat and or air conditioning, solid waste, vector control and safety should be considered. Part of the facility may not be suitable as a shelter and should not be considered when establishing the maximum occupancy number.
2. The maximum occupancy and any restrictions or special requirements for each shelter should be stated in writing to the owner of the facility, the agency to operate the facility, the Emergency Management Agency, and the Division of Family and Children Services. Use **20** square feet for short term shelters < 72 hours (Evacuation), and **40** square feet for long term shelters, > 72 hours duration (Post Impact).
3. Information should be distributed within the community that any emergency shelter opening, whether it has been previously approved or not, must report the opening to the Emergency Management Agency and the Health Department. Upon receiving notice of unlisted shelters opening, the Health Department may send an environmentalist to inspect the facility at the discretion of the District Health Director. The shelter criteria shall be used to evaluate the site and establish its maximum allowable occupancy.
4. Other agencies that have sheltering responsibilities shall be informed of the existence of the shelter, its maximum occupancy, and any restrictions that might apply.
5. All emergency-housing facilities shall be inspected daily. The inspection shall be recorded on the Emergency Housing Facility Report.
6. Any issues found will be discussed with the responsible person at the facility and corrective measures identified. Should the violations present a hazard to the occupants, the shelter manager will be instructed to move the occupants from danger and if necessary relocate them to another shelter. The environmental shift supervisor should be notified and consulted if relocation or reduction in occupancy is considered necessary.
7. The inspection report will be discussed with the shelter manager and signed by both parties. The original will be turned in to the environmental supervisor by the end of the workday.
8. Follow up actions will be taken as necessary to assure the safety of shelter occupants, and to provide them with the best accommodations possible as well as treat them with dignity and respect.

Note: Environmental Health Specialist should identify ESF # 6 and Red Cross representatives and conduct inspections of identified shelters **a minimum of once (1) every four (4) years** to assess fitness of shelter.

**Environmental Health Inspection Report (Pre-Inspection/Post-Inspection)
Emergency Housing Facilities**

Health District: _____ **County:** _____ **Date:** _____

Facility Name: _____ **Agency:** _____

Street Address: _____ **City:** _____ **Zip Code:** _____

Contact Person _____ **Telephone:** _____

1. **Type Shelter:** PF (Pet Friendly)
 FN (Functional Needs)

2. **Space:** Sleeping Capacity Criteria: 20 to 40 square feet per bed
Total Sleeping Capacity: _____

3. **Food Service:** School cafeteria kitchen or kitchen adequate for food preparation
Food Prep Off-Site and catered from approved location

4. **Water Supply:** Type: Public Water Transported Private Well
Quality: Acceptable Unacceptable Unknown
Sampled: Yes No Unknown Date sampled _____
Hot Water: Yes No

5. **Sewage Disposal** Type: Public Septic Tank Non-Sewered Toilet Other
Functioning: Yes No
Serviced/Clean: Yes No Service Company Phone: _____

6. **Showers:** Shower Capacity Criteria: 1 per 25 persons ****may be augmented***
Total Shower Capacity: _____
Acceptable Unacceptable

7. **Toilets:** Toilet Capacity Criteria: 1 per 20 persons ****may be augmented***
Total Toilet Capacity: _____
Acceptable Unacceptable

8. **Handicapped Accessible:** Yes No

9. **Trash/Garbage Handling:** Acceptable Unacceptable
Corrections/Comments _____

10. **Insect & Rodent Control:** Acceptable Unacceptable
Corrections/Comments _____

11. **General Comments:**

Discussed With: _____ Inspected by: _____

Emergency Housing Facilities Notes

Health District:

County:

Date:

**Environmental Health
Emergency Housing Sites Log**

District: _____

County: _____

<i>Date Opened</i>	<i>Location Name of Facility Address</i>	<i>Operating Agency Name of Agency Local Address</i>	<i>Telephone # Local Agency</i>	<i>Capacity</i>	<i>Water Supply</i>	<i>Sewage Disposal</i>
<i>Date Closed</i>		<i>Contact Person</i>	<i>Site Number</i>			

WATER SUPPLIES

The availability of an adequate and safe amount of potable water is a major concern in most natural disasters.

The Environmental Protection Division (EPD), Georgia Department of Natural Resources (DNR) is responsible for public works and the coordination of safe water and sewer systems during disaster related incidents that involve **public** water supplies. Public Health-Environmental Health is responsible for overseeing **individual** water supplies/ **private** wells. Environmental Health would also notify regulated facilities of any public drinking water advisories issued by EPD.

Both public and individual water supplies are subject to contamination and/or failure due to power loss or mechanical breakdown.

The following pages discuss these problems and offer suggested actions to address this challenge.

Again, research and planning prior to the event will enable you to respond quicker and better. Primary and secondary water-testing labs should be identified. Requisition forms and sample submittal instructions for each lab should be kept on file. Advanced preparation of press releases and EXAMPLE PUBLIC SERVICE ANNOUNCEMENTS warning of contamination, giving sources of safe water and providing instruction on procedures to chlorinate or boil water of questionable quality is a necessity.

The treatment and use of water of unknown quality is an action of last resort and should not be taken if bottled water or transported water of a safe quality is available.

Should a water borne outbreak be suspected pertaining to individual water supplies, a water well evaluation should be performed along with samples. Again, any water borne outbreak should be investigated in a collaborative effort with your District Epidemiologist. The water well complaint form can be found in the Education Section at the back of this manual.

INDIVIDUAL WATER SUPPLIES EMERGENCY TREATMENT

1. Boiling of water has been used for many years as a method of killing vegetative forms of bacterial contamination and is a practical treatment for small volumes of water on a temporary basis.
 - a. Water should be free of debris and filtered through cloth or paper towels to remove sediment.
 - b. It is then placed in a clean container that does not contain leachable metals such as lead, antimony or arsenic.
 - c. Bring water to a **rolling** boil for one (1) minute.
 - d. The flat taste can be removed by aerating the water by pouring from one container to another several times.

2. Household bleaches such as Clorox, Purex and others that normally contain approximately 5.25 % available chlorine may be used to disinfect water in dilutions indicated in the following table.

Dosage of Chlorine Bleach		
Volume of Water	Clear Water	Cloudy Water
1 quart	2 drops	4 drops
2 quarts	4 drops	8 drops
1 gallon	8 drops	16 drops
2 gallons	16 drops	32 drops
3 gallons	1/4 teaspoon	1/2 teaspoon
5 gallons	1/2 teaspoon	1 teaspoon
Mix well and allow to stand for thirty (30) minutes before using		

EMERGENCY WATER SUPPLIES STANDARD OPERATING PROCEDURES

1. Work with EMA to identify source of water supplies to be used in the event that the primary water supply is unavailable due to contamination or mechanical failure. Sources to be considered should include nearby approved systems that might be temporarily connected to primary distribution system, bottled water, and water from an approved system that is transported to disaster area in bulk tanks such as military "water buffalos", and food grade trucks or rail cars. Coastal areas may also have access to desalinization plants aboard ships or tankers used for food products.
2. Identify types of transportation available in the area and obtain letters of agreement with the company or agency to provide this vital service to the community. (Work with local EMA)
3. Determine distribution sites throughout the area considering population density, accessibility, parking, safety, and security. (Work with local EMA)
4. If requested, sample every bulk shipment and check residual chlorine level before distribution. Chlorine level should be between 1.0 and 4.0 parts per million at time of consumption. If chlorine level is below 1.0 parts per million, add chlorine sodium hypochlorite (dry powder or non-scented bleach 5.25 %). Mix thoroughly, and let stand for a minimum of 30 minutes. Check chlorine level again, if it meets standard water quality then it may be used, if not chlorinate again and let stand an additional 30 minutes before testing the second time. Chlorine level will dissipate over time. Always recheck before using.
5. If possible, water should be dispensed into containers that are used for no other purpose and have been thoroughly cleaned and sanitized. Care must be taken to not contaminate the dispensing outlet by immersing it in water in the receiving container or allowing contaminated water to be splashed onto it.
6. Each bulk water hauler shall maintain a manifest that indentifies the date and location of water source and the date and location of the water customer.
7. If bottled water is to be used, the brand name, amount, and if possible, the lot number(s) dispensed at each site should be recorded.

Formulas:

Bulk Container Sanitizing

Add 3.75 gallons non-scented bleach (5.25%)/1000 gallons water (200 ppm). Agitate the chlorine solution thoroughly and allow contact with tank and tank hoses for at least 30 minutes. Run chlorine solution to waste through delivery hoses. The tank must then be thoroughly rinsed with potable water before filling.

Establishing chlorine residual using non-scented household bleach (1-4 ppm)

Add 5-6 tablespoons (2.5-3 ounces) non-scented bleach (5.25%) per 1,000 gallons water.

**Environmental Health Inspection Report
Bulk Transported Water**

Health District: _____ **County:** _____ **Date:** _____

Receiving (Distribution) Site Name: _____

Street Address: _____ **City:** _____ **Zip Code:** _____

Operating Agency Name: _____

Contact Person: _____ **Telephone:** _____

Source of Water: Public system Military Base
Private Well Institutional Well
Other (Specify) _____
Name of Supply _____
Address _____

Contact Person _____
Telephone # _____

Water Information: Date loaded _____
Chlorinated at source Yes No
Chlorine level satisfactory Yes No (1.0ppm -4.0 ppm)
Chlorine added at site Yes No
Chlorine re-tested _____ ppm
Water released for distribution Yes
Water Unsafe for Human Consumption

Transporting Agency:
Name _____
Address _____

Contact Person _____
Telephone # _____

Comments:

Inspected by: _____

Discussed With: _____

INDIVIDUAL WATER SUPPLY SYSTEMS (WELLS) STANDARD OPERATING PROCEDURES

In the event of a natural disaster individual water supplies are at great risk of becoming contaminated especially if they are covered by floodwaters. The following procedures will be used in determining the safety of individual water supplies. **It is recommended to conduct a well evaluation on each inspected well using the evaluation form on page 22.**

1. FLOODED WELLS:

- a. Clean well head thoroughly
- b. Flush system until water is clear
- c. Chlorinate well (see procedures on next page)
- d. Allow chlorine to remain in system 8 hours minimum
- e. Flush system to remove chlorine
- f. Collect water sample using aseptic methods
- g. Fill out lab forms completely
- h. Enter sample data in the sample log
- i. Mark sample location on map by collecting GPS coordinates
- j. Send or carry sample to lab
- k. Record and report lab results on well evaluation
- l. Notify owner of results
- m. Give owner instructions on corrective measures if sample is positive
- n. Take follow up action as needed
- o. Collect second sample
- p. Repeat procedure if second sample is positive

2. NON-FLOODED WELLS:

- a. Turn on water for several minutes to make pump turn on
- b. Collect sample using aseptic technique
- c. Fill out lab forms completely
- d. Mark sample location on map by collecting GPS coordinates
- e. Fill out sample log
- f. Send or carry sample to lab
- g. Record and report lab results on well evaluation
- h. Notify owner of results
- i. Give owner instructions for corrections if sample is positive
- j. Collect second sample after corrections have been made
- k. Repeat process if needed, make recommendations as appropriate

BEWARE OF POSSIBLE ELECTRICAL SHOCK IN ALL ACTIONS AROUND WELLS

WELL CHLORINATION INSTRUCTIONS

1. Thoroughly **clean** all accessible surfaces removing loose debris. Then, wash the area with a strong chlorine solution (1 quart of household bleach per 5 gallons of water).
2. **Calculate** the amount of chlorine (unscented household bleach ~5.25%) needed. Determine the amount of water in the well. Use the table below and add the appropriate amount of bleach. A minimum of 50 ppm chlorine solution is required. (Note: Chart calculates approximately 200 ppm concentrations.)
3. Run water from an outside faucet through a hose until a strong chlorine smell can be detected. Place the end of the hose in the well allowing the water to run down the sides of the casing and **circulate** for at least 15 minutes.

WATER DEPTH (FEET)	WELL DIAMETER (4 qts= 1 gallon)					
	2"	4"	6"	8"	24"	36"
20	1 ½ qts	1 ½ qts	2 qts	2 ¼ qts	2 gal	4 gal
40	1 ½ qts	1 ½ qts	2 ½ qts	3 qts	NA	NA
60	1 ½ qts	2 qts	2 ¾ qts	3 ¾ qts	NA	NA
80	1 ½ qts	2 ¼ qts	3 ¼ qts	4 ¼ qts	NA	NA
100	1 ½ qts	2 ½ qts	3 ¾ qts	5 1/2 qts	NA	NA

If depth and diameter are unknown, 1 gallon of bleach can be used.

Extra bleach does not necessarily mean extra disinfection.

Source: University of Georgia Cooperative Extension Service

4. Turn off the hose and open all the taps beginning farthest from the well and enter the home opening each tap, one at a time, until chlorine can be detected. *Please include hot water faucets, toilets, bathtubs, washing machine, etc.*
5. Once the chlorine odor reaches all outlets, let the water system stand ~8 hours. *Preferably overnight. Refrain from any water use during this time.*
6. **Flush** the system of chlorine by turning on an outside faucet letting it run until the chlorine smell dissipates. Finally, run the indoor faucets until the water is clear and the chlorine smells are gone. Do not run unnecessary water into the septic system or allow the chlorinated water to drain into a stream or pond. *The well cannot be flushed too much!*
7. The water should be retested to determine if it's safe to drink. It is recommended that over the next several weeks two additional samples are taken and the results are satisfactory. **Repeated chlorination and/or a well professional should be called if problems remain.**

Water Well Evaluation Report Form

SECTION A: Owner Information District:

County:

Well Number:

Property/System Owner:	Tel 1:
Person requesting Evaluation:	Tel 2:
Property/System Address:	City: Zip Code:
Subdivision Name/Restaurant Name:	County: District:
Final Report: <input type="checkbox"/> Pick up <input type="checkbox"/> Fax Number: <input type="checkbox"/> Mail to (include address if different than above):	

SECTION B: Purpose for Evaluation

<input type="checkbox"/> Loan or Refinance Letter <input type="checkbox"/> Owner Requested , Routine <input type="checkbox"/> Adoption, Foster, Day Care Letter	<input type="checkbox"/> Health Department regulated Non-Public System <input type="checkbox"/> Illness Investigation (include illness reporting form) <input type="checkbox"/> OTHER:
---	--

SECTION C: Well Information

Number of wells (sheet for each):	Type of Well: <input type="checkbox"/> Water Supply <input type="checkbox"/> Irrigation <input type="checkbox"/> Other:
Water Source: <input type="checkbox"/> Drilled Well <input type="checkbox"/> Bored Well <input type="checkbox"/> Spring <input type="checkbox"/> Other:	
Age of Well:	Depth of Well: (Attach Log if Available) Well Contractor (if known):
Components Associated with System: <input type="checkbox"/> Storage tank <input type="checkbox"/> Filter <input type="checkbox"/> Disinfection Treatment <input type="checkbox"/> Other:	
Describe Any Recent Maintenance/Repairs Made To System (Did Disinfection Occur?):	

SECTION D: Septic Information (Attach Copy of On-Site Sewage System Inspection Report)

Age of System: yrs	Type of system: <input type="checkbox"/> Conventional <input type="checkbox"/> Drip <input type="checkbox"/> Mound <input type="checkbox"/> Alt Other:
Describe Any Recent Maintenance/Repairs Made To The System:	
Evidence Of Septic Failure: <input type="checkbox"/> No <input type="checkbox"/> Yes, Describe:	

SECTION E: Well Protection*

<input type="checkbox"/> Met <input type="checkbox"/> Not Met <input type="checkbox"/> Not Observed <input type="checkbox"/> <input type="checkbox"/> <input type="checkbox"/> <input type="checkbox"/> <input type="checkbox"/>	Surface water is diverted away from well. Well cover or seal is present and intact. Curbing is water tight, sloping away from casing, and sufficient to prevent contamination. Vacuum break at all pump, hose and structure spigots. Wells not in service sealed and maintained Area clean and accessible. <i>*System owner should correct any deficiencies in order to improve the operation of their water supply.</i>
---	--

SECTION F: Well Setback Recommendations* (Estimate Distance in Feet)

SEWER LINES	10'	<input type="checkbox"/> Met	<input type="checkbox"/> Not Met	<input type="checkbox"/> Not Observed	___ ft
SEPTIC TANK	50'	<input type="checkbox"/> Met	<input type="checkbox"/> Not Met	<input type="checkbox"/> Not Observed	___ ft
CHEMICAL/PETROLEUM STORAGE	50'	<input type="checkbox"/> Met	<input type="checkbox"/> Not Met	<input type="checkbox"/> Not Observed	___ ft
PIT PRIVY	100'	<input type="checkbox"/> Met	<input type="checkbox"/> Not Met	<input type="checkbox"/> Not Observed	___ ft
ANIMAL OR FOWL ENCLOSURE	100'	<input type="checkbox"/> Met	<input type="checkbox"/> Not Met	<input type="checkbox"/> Not Observed	___ ft
SEPTIC ABSORPTION FIELD (DRIP, MOUND, ETC.)	100'	<input type="checkbox"/> Met	<input type="checkbox"/> Not Met	<input type="checkbox"/> Not Observed	___ ft
SEEPAGE PITS, CESSPOOLS	150'	<input type="checkbox"/> Met	<input type="checkbox"/> Not Met	<input type="checkbox"/> Not Observed	___ ft
SOLID WASTE DISPOSAL SITE	1000'	<input type="checkbox"/> Met	<input type="checkbox"/> Not Met	<input type="checkbox"/> Not Observed	___ ft

** These distances are required under DNR's Water Well Standards Act; Any setbacks not in compliance may compromise the well quality.*

Set Coordinate system to North American Datum 1983 (NAD83) **GPS Well Position: (Decimal Degree):**

Lat: _____ ; Long: _____

SECTION G: Bacterial Sample Results

A water sample was taken at the time of the evaluation to test for coliform/fecal coliform bacteria. Results were shown to be SATISFACTORY UNSATISFACTORY.

See the reverse side of this form for addition explanation.

Sample Code:

Evaluating Environmentalist:	Title:	Date:	I verify this data to be correct at the time of the evaluation. This verification shall not be construed as a guarantee of the proper functioning of this water system for any given period of time. No liability is assumed for damages that may be caused by evaluation.

A water sample was obtained from the water well serving this property for the purpose of performing a qualitative bacteriological examination. A coliform test was conducted to indicate the presence or absence of bacteria contamination. **Satisfactory** results are negative for the presence of coliform bacteria. The presence of coliform/fecal coliform is **unsatisfactory**, and the use of a positive water source should be discontinued until maintenance or repairs can be made to prevent any future contamination. This test does not include any Chemical “screening” of the water source.

The County Board of Health is not responsible for construction of individual wells. The County Board of Health does not, by any action taken, assume any liability for damages that are caused, or may be caused, by improper well construction. Furthermore, issuance of this form shall not be construed as a guarantee concerning the continued water quality from any individual well.

SKETCH: Site sketch should include distances and location of (1) property line boundaries (2) well location (3) location of all septic systems within 100’ of well, including on any adjacent properties (4) permanent structures on property (5) water and sewer lines

RECOMMENDED ACTIONS:

Environmental Health Section Water Well Evaluation Report Form Definitions and Instructions

The County Board of Health is routinely asked to conduct evaluations of existing private water wells. Such evaluations shall be based on a site visit and the collection of a water sample to determine the safety of an existing nonpublic or individual well as a water source. The Health Department Environmentalist conducting the evaluation should document their findings by completing this form to verify the status of system at the time of the evaluation. Please use the following definitions and instructions when completing this evaluation form.

Section A through C Owner and Well Information

Sections A and B may be filled out by the owner or applicant. Wells can be shared, so the person requesting service may differ from the owner of the well. When a well owner performs the sampling please have the applicant use the Homeowner Well Evaluation Form and the Illness Report Form. Forward these forms to the Department.

In Section C, please note that wells used for irrigation also fall under DNR's Water Well Standards Act. The following definitions are to be used:

Drilled Well any well excavated by rotary or percussion, hydraulic drilling, having a casing that extends from ground surface through an impermeable formation to an aquifer where adequate capacity is obtained. Usually the casing is smaller in diameter (2"~ 6") and is sometimes referred to as a "deep well".

Bored well means any well excavated by an earth auger in which the casing extends from the ground surface to the aquifer. Usually these wells are 24" in diameter or greater and are referred to as "shallow wells".

Components – The water sample should be taken at the well, or "point source", before the distribution system (storage tank, filters, treatments units, etc). These components can compromise water quality but this evaluation is for the protection of the well, not "point of use" components.

Section D Septic Information

Please include the OnSite Sewage Management Inspection Report to determine if required setbacks have been met. Septic systems on any adjacent properties must also be considered when determining all septic setbacks.

Section E Well Protection

These areas of well protection are requirements found in DNR's Water Well Standards Act of 1985, revised 2001 (O.C.G.A. 12-5-120 **et seq.**) and DPH's Rule Chapter 290-5-55 Drinking Water Supply. If any items in this table that are not applicable to the well being evaluated, mark the appropriate "Not Observed" box(s).

"Surface water is diverted away from well" 12-5-134 (1)(B) The well should be located as far removed in a direction opposite to groundwater flow as the general layout of the property and surroundings allows. Avoid low lying areas and depressions where standing water is likely to accumulate around the well.

"Well cover or seal is present and intact" 12-5-134 (1)(J) The upper terminal of the well

shall be protected by a sanitary seal or cover to prevent entrance of pollutants to the well.

“Curbing is water tight, sloping away from the casing, and sufficient to prevent contamination” 12-5-134 (1)(R) All individual and nonpublic wells shall be curbed at the surface by the owner with water tight curbing... sloping away from the casing.

“Vacuum break at each spigot” DHR Rule 290-5-55.03 (6)(7) No outlet from a water supply shall be installed or maintained so that back siphonage is possible.

“Wells not in service sealed and maintained” 12-5-134 (6)(A)(B) Temporarily abandoned and abandoned wells shall be sealed and the well maintained whereby it is not a source or channel of contamination or pollution when not in service.

“Area clean and accessible” 12-5-134 (1)(c) Every well shall be located so it will be accessible for cleaning, treatment, repair, testing, inspection, and such other maintenance as may be necessary. The area should be clean of debris and infestation.

Section F Well Setback Requirements

In order to reduce risks of contamination and prevent any potential for polluting, the Water Well Standards Act requires these setbacks found in this Section. The well should maintain certain minimum horizontal distances from these setbacks. Mark this form as Met, Not Met, or Not Observed. Please note that “Chemical/Petroleum Storage” includes items such as fertilizers, pesticides, and fuel tanks. These items are often stored in well houses and should be brought to the attention of the well owner as unsafe.

GPS Well Position

Please set the map projection coordinate system to North American Datum 1983 (NAD83) and record the wayward point for the well location in Decimal Degrees Format. GPS units can display in many coordinate systems and formats, so please check that you are using the designated format before recording waypoints. Under the Settings is a function to change formats, if needed. See the GPS’s manual for details.

Section G Bacteria Sampling

A water sample will be taken to perform a qualitative coliform/fecal coliform test. Satisfactory results are negative for the presence of coliform bacteria. The presence of coliform bacteria is unsatisfactory, and the use of a positive or unsatisfactory water source should be discontinued until maintenance or repairs can be made to prevent any future contamination.

Sampling Procedure:

1. The sample should be taken from an outside spigot to avoid running unnecessary water into the septic system.
2. Run water for several minutes ensuring that the sample comes from the source. If possible, the sample should be taken before it enters a storage tank, distribution system, or point of use filtration/treatment system.
3. Sanitize spigot or faucet prior to taking the sample. Sanitizing may include utilizing either alcohol swabs or flame. If present, the aerator and vacuum break should be removed. Please note that the vacuum break may require a tool for removal.
4. A sterilized sample bottle must be used. Do not touch the inside of the bottle or lid. Do not allow dirt or debris to contaminate the bottle.

5. Take the sample, filling bottle to 100 ml line. If this is a recheck, a DPD pool test kit can be used to verify any residual chlorine still present.
6. Close bottle, once again, keeping sure not to contaminate sample.
7. Sample must be sent to the Health Department or certified lab within 24hrs.

Homeowner shall be notified immediately of any unsatisfactory results. Individuals should be advised not to use the well for drinking or cooking purposes. Chlorination instructions should be provided in order to disinfect the well. It is recommended that over the next several weeks two additional samples are taken and are satisfactory. Repeated chlorination and/or a well professional should be called if problems remain.

COLLECTING WATER SAMPLES STANDARD OPERATING PROCEDURES

1. Carefully remove aerator screen or other devices attached to faucet.
2. Turn on the cold water and allow water to run for two to three minutes to insure that the pump comes on and freshly pumped water is in the system.
3. Sterilize the outer surfaces of the faucet by flaming with a propane torch or cotton balls soaked in alcohol.
4. Turn on water without touching water contact surfaces of the faucet.
5. In a sterilized bottle, collect 100 mL of water leaving the top of the bottle open as short a time as possible. Be sure not to touch the interior of the bottle or top. Replace the top and tighten securely.
6. Fill out sample form **COMPLETELY**. If you have Global Positioning System equipment place the coordinates on the sample form.
7. Contact Primary lab. Check their operating status. If the Primary lab is unavailable, contact a secondary lab. Note: EHS may have incubators for samples.
8. Submit sample as requested by lab.
9. If sample is part of an area survey, locate on map and indicate sample number. Sample number and name should be entered in sample log and lab results entered when they are received.
10. Notify responsible party of results and if necessary provide instructions on corrective actions.

WATER SAMPLE LOG INSTRUCTIONS

1. Enter month and county name in the spaces provided in the header section.
2. Enter the day of the month in the date cell.
3. Enter the sample number in the sample # cell. You must establish a system of numbering samples so that no duplication of numbers occurs.
4. Enter the name of the well owner or system name in the upper half and the telephone numbers of the responsible person in the lower half of the name cell.
5. Enter the street address or the road name and mailbox number in the upper section and the global positioning coordinates in the lower section of the address cell.
6. In the well cell enter the type of well; Drilled, Bored, Dug, Spring; the diameter of the well in inches; and the depth of the well if known.
7. In the sample type cell indicate whether this is an Initial sample or a Repeat sample include a number to indicate if this is the **2**nd. or **3**rd., etc. sample taken of this supply.
8. In this cell indicate whether this system has been previously chlorinated or not by using Yes or No.
9. When the laboratory results are received they should be entered in the upper section of the results cell and the date the analysis was completed in the lower portion of the cell.
10. In the date notified cell you should enter the month and day that the results were given to the owner of the well or system.
11. If the results of the sample are positive, the date that the well is chlorinated by a Health Department employee or written instructions on proper chlorination techniques are given to the owner of the system or well should be entered in the appropriate column of the chlorinated cell.
12. If this sample is positive a date to re-sample the supply should be established at the time that the results are given to the owner and entered in this cell.

Environmental Health Water Sample Log

Health District: _____

County: _____

Date	Sample #	Name	Address		Well			Sample Type I.R.	Well Previously Chlorinated		Results	Date Notified	Date Chlorinated	Inst. Given	Re-Sample Date
		Telephone #	N	W	Type	Size	Dept		Yes	No	Date				

REGULATED FACILITIES
Standard Operating Procedures
Water Interruption

(Flooding, Loss of water pressure, Break in water line, “low pressure events”, Repairs or Construction)

Ensuring safe, potable water in an emergency/disaster situation is a critical function of environmental health. Safe drinking water may include boiled, bottled or treated water, depending on the hazard. Natural disaster events such as floods or water main interruptions may render water unsafe to drink and environmental health may be asked to provide guidance to regulated facilities such as foodservice establishments, Tourist Accommodations and Public Pools. All regulated facilities should be encouraged to have an emergency plan approved by the health authority that addresses safe water during an emergency event.

Imminent health hazard related to flooding:

How should EHS respond to an imminent health hazards when regulated facilities temporary lose potable water supply due to flooding or some other unforeseen reason?

EPD issues three types of orders for Emergency Water Interruptions:

1. Do not use
2. Do not drink
3. Boiled Water Advisories

Do not use/Do not drink orders are issued when the water contains a chemical contaminant that cannot be removed by boiling. In this case, bottled water or water from an approved source must be used for all drinking (including baby formula and juice), brushing teeth, washing dishes, making ice and food preparation until further notice.

During a Do Not Drink/Do Not Use Advisory, the following guidelines should be followed:

Do not drink, brush teeth, bathe, shower in or swim in the water

Do not wash clothes or wash dishes

Do not let pets drink or bathe in the water

Do not boil the water – boiling water may release more toxins in the water.

Regulated facilities that wish to continue service during this type of order shall have a preapproved emergency water plan in place. This means that the facility must demonstrate that it has a contractual supply of potable water to meet the demands of its operation. This could include the following:

1. A supply of containers of commercially bottled drinking water;
2. One or more closed portable water containers;
3. An enclosed vehicle water tank;
4. An on-premises water storage tank; or
5. Piping, tubing, or hoses connected to an adjacent approved source.

Approval of an alternate source of potable water should be granted by the District Medical Director. An alternate water supply shall not exceed 7 days unless renewed by the District Medical Director.

Boiled water advisories are issued when an event has occurred allowing the possibility for the water distribution system to become biologically contaminated. An advisory does not mean that the water is contaminated, but rather that it could be contaminated; because the water quality is unknown, customers should assume the water is unsafe to drink and take the appropriate precautions.

Food Service Establishments

Foodservice rule 290-5-14-.03 subsection (2) (n) addresses this issue. It states that the person in charge (PIC) of the food service establishment must immediately discontinue operations where there is interruption of water supply for more than two (2) hours and he/she must notify the Health Authority.

I. Assessment

In the event of an emergency involving a contaminated water supply, appropriate food establishment responses must be taken after an assessment of multiple factors including but not limited to:

- The complexity and scope of food operations,
- The onset and duration of the emergency event,
- The impact on other critical infrastructure and services; and
- The availability of alternative procedures that can be used to meet Food Code requirements.

A food establishment manager (or the “Person-in-Charge”) is responsible for conducting both initial and ongoing assessments to ensure consistent compliance with food safety requirements.

II. Response

The following are temporary alternative procedures that can be taken to address specific affected food operations during a biological contamination of the water supply (boil water advisory). Where “boiled” water is indicated, the water must remain at a rolling boil for at least **one** minute. Although chemicals (e.g. bleach) are sometimes used for disinfecting small amounts of household drinking water, chemical disinfection is generally not an option for food establishments because of the lack of onsite equipment for testing chemical residuals. Each facility needs a written plan outlining the alternative procedure they will implement during a boiled water advisory. The following information may be used by the establishment to develop their plan and provides immediate guidance to EHS should a water interruption occur.

Affected Operations

Drinking Water

Alternative Procedures

- Use commercially bottled water and/or water that has been boiled for at least 1 minute

And/Or

- Haul water from an approved public water supply in a covered sanitized container

And/Or

- Arrange to use a licensed drinking water tanker truck.

Beverages made with water – including post mix carbonated beverages, auto-fill coffee makers, instant hot water dispenser, juice, tea, etc.**Alternative Procedures**

- Discontinue use of post-mix carbonated beverage machine, auto-fill coffee makers, instant hot water heaters, etc. using auto-fill.

Additional information for safe drinking water can be found at the following website:

www.epa.gov/ogwdw/faq/emerg.html.

Ice Making**Alternative Procedures**

- Discard existing ice.

And

- Discontinue making ice
- Use commercially manufactured ice from an approved water source.

Preparing food products requiring water**Alternative Procedures**

- Discard any ready-to-eat food prepared with water prior to the discovery of the contamination
- Prepare ready-to-eat food using commercially bottled or boiled water.

- Limit the menu to ready to eat items or cook to serve items with limited to no preparation.

Washing / Soaking produce**Alternative Procedures**

- Use pre-washed packaged produce
- Use frozen/canned fruits and vegetables

And/Or

- Wash fresh produce with boiled, commercially bottled water, or safe potable water hauled from a public water supply system.

Thawing of frozen foods**Alternative Procedures**

- Thaw only in the refrigerator or as part of the cooking process.

Cooking**Alternative Procedures**

- Use commercially bottled water

And/Or

- Haul water from an approved public water supply in a covered sanitized container

And/Or

- Arrange to use a licensed drinking water tanker truck.

Handwashing

Alternative Procedures

- Use heated bottled water, boiled water, or safe water hauled from an approved public water supply

Cleaning and Sanitizing utensils and tableware

Alternative Procedures

- Use single service utensils and tableware.

Or

- Use the existing automatic dish machine or the 3-compartment sink. Make certain that the sanitization step is being properly conducted (sanitizer concentration/temperature).

Spray Misting Units –used to spray produce, seafood, meat cases, etc

Alternative Procedures

- Discontinue use of misters.

Procedures for flushing, cleaning and sanitizing after water interruption:

A food establishment that was ordered or otherwise required to cease operations may not re-open until authorization has been granted by the regulatory authority.

After either the municipality or regulatory authority has provided notice that the water supply is safe to use, the operator must ensure the following has been completed:

- Flush pipes/faucets: follow the directions of your water utility (in the newspaper, radio, or television) or, as general guidance, run cold water faucets for at least 5 minutes.
- Equipment with waterline connections such as post-mix beverage machines, spray misters, coffee or tea urns, ice machines, glass washers, dishwashers, and other equipment with water connections must be flushed, cleaned, and sanitized in accordance with manufacturer’s instructions.
- Run water softeners through a regeneration cycle.
- Drain reservoirs in tall buildings.
- Flush drinking fountains: run continuously for 5 minutes.
- Ice Machine Sanitation:
 - o Flush the water line to the machine inlet
 - o Close the valve on the water line behind the machine and disconnect the water line from the machine inlet.
 - o Open the valve, run 5 gallons of water through the valve and dispose of the water.
 - o Close the valve.
 - o Reconnect the water line to the machine inlet.
 - o Open the valve.
 - o Flush the water lines in the machine.

- o Turn on the machine.
 - o Make ice for 1 hour and dispose of the first batch of ice.
 - o Clean and sanitize all parts and surfaces that come in contact with water and ice, following the manufacturer's instructions
- Wash, rinse, and sanitize all food contact surfaces, 3-compartment sinks and utensils.

Food Establishments utilizing a Non-Public Water Supply (privately owned well) must be 1) Flushed; 2) Disinfected as outlined in the EH Disaster Response Manual; and 3) Sampled.

Source: 2004-2006 Conference for Food Protection
Environmental Health Emergency Response Guide-Advanced Practice Center

Tourist Accommodations

During a boiled water advisory, patrons should only use water for flushing toilets. Since it is impracticable for a TA patron to boil water, it is not recommended that the water be used for personal use such as drinking, bathing, brushing teeth or washing their hands.

TA operators and owners should follow the same procedures for flushing, cleaning and sanitizing as outlined in the previous section.

Public Swimming Pools

During a boiled water advisory, bathing facilities and water fountains should not be used at public swimming pools. Water may be used for flushing toilets and facilities should establish temporary hand washing stations using potable water. Public pools are disinfected and therefore generally considered safe, but management must continually test the water to ensure disinfectant residual. At a minimum, the water should be tested prior to the pool opening, during operation and after closing to ensure disinfectant residual.

Should water have to be added to the pool to "top it off" or to remove chemicals such as cyanuric acid, the pool should be shocked treated following the fecal incident guidelines.

Public Pool owners and operators should flush their bathing and drinking facilities as outlined in the previous procedure.

OUTDOOR SEWAGE SPILL GUIDANCE

During a disaster event, such as major flooding, there may be a need to provide guidance concerning outdoor sewage spills to the public. This guidance can include informing concerned citizens on the health risks associated with raw sewage. Other information can involve proper methods for containment, cleaning, and disinfection.

The standard procedures and guidance for such an event are detailed in this section.

Standard Procedures for Cleaning Up Sewage Spills Outdoors

Health Hazards

Many disease-causing agents are potentially present in raw sewage. These organisms include bacteria, viruses, fungi and parasites. Most illnesses associated with raw sewage exposure produce mild to severe flu-like or cold-like symptoms. However, more serious illnesses, such as Hepatitis A, can be contracted through direct contact (mouth, eyes, nose, and ears) with raw sewage. With respect to HIV (AIDS) and HBV (Hepatitis B), the Center for Disease Control and Prevention has stated these bloodborne diseases have not been linked to exposure to sewage and the risk is virtually nonexistent.

The survival of microorganisms depends on a number of factors: location, type of surface contaminated, whether disinfectants are used, and also on environmental conditions such as humidity, temperature, and sunlight. Sunlight (UV radiation) reduces the survival rate of disease-causing agents with numbers decreasing rapidly as exposure to UV radiation increases.

Since microorganisms can cause disease by entering the body through the mouth, eyes, ears, nose, or through cuts and abrasions to the skin, proper hygiene, and appropriate personal protective equipment (PPE) must be utilized when the potential for direct contact with raw sewage is possible.

The following are recommended procedures for cleaning up outdoor sewage spills

1. Contain

Control and minimize the spill. Investigate to determine the source(s) and prevent additional sewage from spilling. Use sandbags, dirt, and/or plastic sheeting to contain the spilled sewage. Keep spills contained to the site and out of gutters, storm drains, and public waterways by shutting off or not using the water. If the area in which the spill occurred is accessible to the public or domestic pets, such as a park or school, the contaminated area must be clearly marked or cordoned off to restrict access. Signs should be posted informing the public of the hazard, such as “Keep Out, Sewage Contamination”, until the spill cleanup has been completed.

2. Clean

Clean up the spilled sewage (both solids & liquids) and properly dispose of the waste. If the spilled material can't be recovered using hand tools, a commercial vacuum / pump truck should be called to remove all visible liquid and solid material. Small spills (< 25 gallons) can be cleaned up with a mop and a bucket whereas larger spills (> 25 gallons) should be handled by an environmental clean-up contractor or utility contractor. Affected areas can include, but are not limited to, the ground, storm drainage system, and waterways such as streams, ponds, and wetlands. Proper disposal of sewage consists of disposing of it in a permitted treatment system. Failure to respond promptly often results in much higher cost of cleanup.

Protective clothing, gloves, goggles, masks or face shield (at a minimum, rubber or latex gloves and rubber boots) should be worn when cleaning up a sewage spill. Dispose of gloves and wash rubber boots when leaving spill site.

3. Disinfect

Sewage spills require immediate attention and may **require disinfection** to accelerate and shorten the time it will take to make the site safe and accessible. When the area in which the spill has occurred is impervious, such as concrete or pavement, a chlorine/water solution (bleach) can be used to disinfect. On these hard surface areas it is safe to use a 10% bleach to water solution, or 1 part bleach to every 9 parts of water.

When spills occur on pervious areas, such as soil, and if the spill has occurred in a populated area, odor may be an issue or within 100 feet of surface water, hydrated lime should be applied to the area in place of chlorine bleach. Hydrated lime is formally known as Calcium Hydroxide and commonly known as slaked lime or masonry lime. Please note that hydrated lime is a caustic material and can be dangerous to handle and apply. Lime should only be used or applied by people experienced in using this material. The lime should be sprinkled onto the spill so the spill is dusted mostly white on the surface. If the residue is thicker in some places use a rake to mix the lime and the residue. Enough hydrated lime should be applied to raise the pH to at least 12. The pH should stay at 12 for at least 2 hours. You can test the pH by using litmus paper obtained at a chemical supply facility. After a day, rake up the thicker residue. If there is still white lime dust visible on the soil or turf, water it in until the white dust is gone.

Do not mix cleaning/disinfecting products or chemicals. Cleaning products can react with one another to produce toxic vapor or liquid substances.

After the spill area has been disinfected and the site has dried (7 days after the chlorine solution or hydrated lime has been applied), the barriers and signage may be removed and access to the area restored.

NON-SEWERED TOILET STANDARD OPERATING PROCEDURES

The availability of clean, safe, and sanitary methods of disposing of human wastes is a major problem after a disaster such as a hurricane or earthquake. Before the occurrence of a disaster in your area, steps must be taken to assure that this problem is handled in a planned and well-executed manner.

You may be asked to assist with identifying a source or sources of portable toilets in the area that can supply large numbers of units and has the equipment to service them daily.

Letters of agreement to supply the projected number of units should be negotiated and signed between the County and the provider. These letters should state that the provider will supply the agreed upon number of units to the County at the price rate in force for that size contract before the probability of a disaster occurring. They should also state that all waste shall be disposed of in such a way as to comply with all rules, regulations, and laws governing such operations. (If asked to assist, work with the local EMA.)

Identify potential locations for setting up portable toilets. Locations considered should be near areas where large numbers of people are expected to be after the hurricane such as planned food or water points of distribution sites, designated shelters, and locations where emergency assistance and recovery operations are provided.

1. All non-sewered toilets set up as the results of a disaster must be provided and serviced by a company that is Certified by DPH and approved by the local Health Authority. The contractor must provide documentation that all waste from such units will be transported and disposed of in a manner that is in compliance with all applicable rules, regulations, and laws.
2. The location of non-sewered toilets should be such that every person affected by the disaster will have access to a functional, clean toilet within a reasonable walking distance. Toilets will be located in areas that are clear of fallen or damaged power lines or trees, have clear walkways in the immediate area, and have passable roads to allow service vehicles to reach the toilets. Where possible, exterior lighting should be provided to insure safety during hours of darkness.
3. The number of toilets shall be such that one will be available without a lengthy wait and that they can and will be serviced as necessary to prevent overflowing.
4. The toilet units shall have the name of the company that owns and / or services them along with a unit number / letter or combination that is unique to that unit for identification purposes.
5. All agencies or companies providing and/or operating non-sewered toilets shall provide the Health Department with the location of their units along with the name or names and telephone numbers of employees that can be contacted at any time concerning the servicing of the units.

6. All units will be inspected daily and the inspection information recorded on the non-sewered toilet inspection report. The environmentalist will note the time that the inspection was completed and sign the form. He will then post the report in a conspicuous place on or near the units. If an employee of the contractor is at the site the environmentalist will discuss any violations with him and establish a plan of correction that includes actions to be taken and time of completion. If an employee is not at the site the environmentalist will notify the environmental shift supervisor of any violations and he will then contact the contractor to obtain corrective action.
7. Should a unit be full or unusable for some other reason, the environmentalist will place a "Do Not Use" placard on the door. It will have the reason written on it along with the time and signature of the environmentalist. The inspection report will reflect the unit number(s) of unit(s) taken out of service.
8. The "Do Not Use" placards are to be removed only by the operator servicing the unit(s). He will write the corrective measures taken along with the date and time and turn them in to his supervisor who will turn them in to the environmental supervisor on a daily basis.
9. The failure of a contractor to keep units cleaned, serviced, and stocked with supplies could lead to the suspension or revocation of his permit and the cancellation of his contract to provide services.
10. Document cost of program so that the County can file a request for re-imburement with FEMA. Remember to include costs incurred by the department as well as the cost of the contract with the provider.

**Environmental Health Inspection Report
Non-Sewered Toilets**

Health District: _____ **County:** _____ **Date:** _____

Site Name: _____ **GPS: Lat** _____ **Long** _____ **Time:** _____

Street Address: _____ **City:** _____ **Zip Code:** _____

Agency: _____

Contact Person: _____ **Telephone:** _____

Contractor: _____ **License #:** _____

Contact Person: _____ **Telephone:** _____

Number of Units Inspected: _____

Satisfactory **Unit #** _____ _____ am pm

Unsatisfactory **Unit #** _____ _____ am pm

Unit #	Full	No Supplies	Dirty	Bad Repair	Taken Out of Service	Sticker #	Released	Comments

Corrective Action _____

Disposal Site: _____ **Agreement Date:** _____

Inspected by: _____ **Discussed with:** _____

**Environmental Health Inspection Log
Non-Sewered Toilet Site Locations**

Health District:

County:

Set-up Date	Location Street Number and Name School/Shopping Center	Number of Units	Contractor/Provider Name/Local Address Local Contact	Telephone Number	Service Frequency Schedule	Disposal Site
				Corporate Office		

SOLID WASTE MANAGEMENT STANDARD OPERATING PROCEDURES

Natural disasters such as hurricanes, earthquakes, and floods generate volumes of solid wastes almost beyond the scope of the imagination. Plans to deal with the problem need to be comprehensive, detailed, and innovative.

The Georgia Department of Natural Resources (DNR) serves as the coordinator for ESF#3, Public Works, and will assume primary responsibility for coordination among ESF#3 primary and support agencies. The Georgia Department of Transportation along with local Public Works Departments are tasked with removal and disposal of debris, as appropriate, to provide emergency access to disaster areas or to assist in eliminating health and safety problems associated with debris. Environmental Health may assist with public health messaging, general information, and investigating complaints.

An inventory of agencies, governments, and companies that are currently involved with solid wastes management should be created. It should include the resources of each, along with the name and telephone number(s) of a contact person.

1. Contact the local Emergency Management Agency, along with governmental representatives and ESF #3, Public Works to identify potential locations that can be used as temporary storage sites for rubbish such as trees, building materials, and household waste that does not contain food products. This task must be completed and integrated into the community disaster plan in order that rubbish cleared from streets and highways during the re-entry operations can be taken to an identified storage site and will not have to be handled unnecessarily. Sites should be located throughout the community to reduce hauling time and some of them need to be near the major highways that will be used by relief and recovery personnel. Geographical features like rivers and flood prone areas need to be kept in mind because they might limit access to a potential site.
2. Work with the County to prepare maps showing the locations of identified temporary storage sites and have them copied for distribution to the re-entry personnel that will be clearing roads and highways back into the disaster area. Maps should show a number of alternative sites equal to one-half of the primary sites.
3. Prepare information on handling of wastes for distribution to the media and residents as they return to the area. These could be provided to the occupants of shelters so they would know what to do when they start there clean up upon returning home.
4. Try to determine the amount and type of wastes generated and the method by which it was disposed of. This should be recorded and reported to emergency management agencies in order to enable them to better plan for similar occurrences in the future.
5. Maintain contacts with local, state, and federal agencies involved with these activities in order to coordinate activities to improve efficiency.

COMPLAINT \ INCIDENT REPORT INSTRUCTIONS

The Complaint\Incident Report Form is used to record the receipt of a complaint or notification of an incident that needs to be investigated and assigned to an environmentalist for response.

It identifies the source of the complaint or report, tells what type of complaint or incident it is, gives the location and a brief description of the problem to be investigated, and identifies the environmentalist that is assigned to investigate or respond to the call. It also assigns a control number that is used to track the response to the call.

The environmentalist investigates the complaint and records his/her actions in the disposition section giving a brief description of conditions found, corrective measures recommended or ordered. If the call is referred to another agency, document the name of the agency, date of referral, and the contact person.

The environmentalist will sign and date the form. If a follow-up action is indicated the environmentalist should include a proposed date in the narrative.

The program supervisor will review the report and close the file if no further action is needed, or designate a follow-up date to continue actions necessary to satisfactorily conclude the case. He or she should support the time frame suggested by the initial investigator unless he or she feels that an earlier date is appropriate. If so he or she should notify the environmentalist immediately.

**THIS FORM WILL BE USED FOR SEVERAL
ENVIRONMENTAL HEALTH PROGRAMS**

**Environmental Health
Complaint/Incident Report**

Health District: _____ **County:** _____ **Date:** _____

Complainant's Name: _____ **Telephone #:** _____

Street Address: _____ **City:** _____ **Zip Code:** _____

1. **Program:** Food Service Drinking Water
 Sewage Disposal Solid Waste
 Vector Control Swimming Pool/Recreational Waters

2. **Health Hazard:**
 Hazardous Material Sewage
 Injury Indoor Air Quality
 Illness Common Source Outbreak

3. **Complaint/Incident Location:**

4. **Complaint/Incident Description:**

4. **Assigned to:** _____ **Date:** _____ **Time:** _____

5. **Disposition:**

Submitted by: _____ **Date:** _____

Reviewed by: _____ **Date:** _____

Close record: _____ **Follow-up date:** _____

COMPLAINT/INCIDENT LOG INSTRUCTIONS

This document is used to record the receipt of a complaint or notification of an incident, assign a unique number to it for tracking purposes, identify the unit or staff member it is assigned to, the date of the assignment, the date the initial response occurred, the date follow-up action is scheduled, and finally the date the complaint file is considered closed.

- DATE RECEIVED:** The date the complaint is received by the Health Department. Enter as MM/DD/YY.
- CONTROL NUMBER:** This number will be unique to this specific call. It will consist of three digits sequentially assigned starting at 001 each date.
- ASSIGNED TO:** Enter the name of the staff member to whom the complaint is assigned. If an individual name is not known at this time enter, the agency and unit so follow-up action can be verified.
- DATE ASSIGNED:** Enter the date the complaint is given to a staff member or unit to investigate. Use the format MM/DD/YY.
- RESPONSE DATE:** Enter the date that the initial response occurred (inspection, interview, etc.) using the format MM/DD/YY.
- RE-INSPECT DATE:** This is the date that the inspector has indicated that corrections should be completed by and on which he/she will re-inspect to confirm compliance.
- CLOSED DATE:** Enter the date that the investigator gives indicating that the problem has been satisfactorily resolved. The file should be closed only after the supervisor reviewing the file concurs.

**Environmental Health
Complaint/Incident Log**

Health District:

County:

<i>Date Received</i>	<i>Control Number</i>	<i>Assigned To</i>	<i>Date Assigned</i>	<i>Response Date</i>	<i>Re-Inspect</i>	<i>Date Closed</i>

HAZARDOUS MATERIALS

(To Include Chemical or Toxic Releases)

The field of hazardous materials is one that most health departments have not been involved with to any significant level. However, these materials pose a real danger to the people of this state and all of its counties. With tons of hazardous materials being shipped through Georgia daily, the potential for a disaster is present on any road, railroad and at any storage facility or manufacturing plant.

The Georgia Environmental Protection Division (EPD), Georgia Department of Natural Resources (DNR) - is the ESF Coordinator for ESF-10, Hazardous Materials, and this ESF supports the National Response Framework ESF#10 (Oil and Hazardous Materials Response Annex).

DNR and GEMA/HS will coordinate with appropriate agencies and organizations to ensure operational readiness. DNR and GEMA/HS will develop and maintain Standard Operating Procedures (SOPs). DNR will coordinate, integrate, and manage overall state efforts to detect, characterize, contain, clean up, dispose of or minimize releases of oil, hazardous substances, radioactive materials or CBRNE weapons. DNR will coordinate, integrate and manage overall state efforts to prevent, mitigate, or minimize the threat of potential releases to the environment. DNR's Environmental Protection Division (EPD) will provide expertise on environmental effects of oil discharges, hazardous substance releases; CBRNE weapons releases, pollutants, contaminants, and environmental pollution control techniques.

As a support agency the Georgia Department of Public Health in conjunction with the Georgia Poison Control Center will:

Provides assistance on all matters related to the assessment of health hazards related to a hazardous materials incident and protection of response workers. Determine whether illnesses, diseases, or complaints may be attributable to exposure to a hazardous material. Establish disease/exposure registries and conducts appropriate testing. Provide information on the health effects of toxic substances. Provide assistance with sampling water supplies when they are suspected of being contaminated by a pollutant or hazardous material.

A recent example of this support occurred in January 2013 in Crisp County, Georgia after an explosion occurred at a local chemical company. Public Health fielded calls from concerned citizens and referred some to Georgia Poison Control when needed.

Since the Health Department is responsible for the health and safety of the public, plans should be made to respond to such a disaster should it occur. Several items are listed below which can help you plan your response actions.

1. Meet with the local Emergency Management Agency staff to discuss what hazardous materials have been identified as being present in the county or district on any given day. Contact and become a member of Local Emergency Planning Commissions.
2. Build a reference library of information on known materials. Learn what special dangers or problems these materials pose. You may be the only person locally that has information on hand. The DOT hazardous materials response book is a good start.

3. Develop contacts with management of local industries to obtain information on materials they use. They should have Material Safety Data Sheets on any dangerous materials they have or produce. These industries may be identified through DNR generators lists, Georgia Department of Community Affairs, Chamber of Commerce, etc.
4. Prepare a simple fact sheet on materials identified for quick reproduction and distribution in case of an accident.
5. Include all people that you know of with knowledge or expertise in this field in your contacts file and also in your resources file in case you need them for consultation in the event of an incident. This would include agencies such as DNR, ATSDR, CHEMTREC, OSHA, NIOSH, etc.
6. All activities concerning hazardous materials should be documented using the "Complaint/Incident Report Form" and tracked using the "Complaint/Incident Report Log."

**Environmental Health Inspection Report
Hazardous Materials Inventory**

Health District: _____ **County:** _____ **Date:** _____

Name of Company: _____ **Telephone:** _____

Address: _____ **Emergency Telephone:** _____

Contact Person: _____ **Telephone:(W)** _____ **(H)** _____

1. **Type of Facility** _____

2. **Primary Product** _____

3. **Characteristics of primary product(s):**
a. Name: _____ Formula: _____

b. Name: _____ Formula: _____

- | | | | |
|---------------------------------------|---|---|---------------------------------------|
| <input type="checkbox"/> Flammable | <input type="checkbox"/> Acidic | <input type="checkbox"/> Caustic | <input type="checkbox"/> Corrosive |
| <input type="checkbox"/> Radioactive | <input type="checkbox"/> Explosive | <input type="checkbox"/> Gaseous | <input type="checkbox"/> Carcinogenic |
| <input type="checkbox"/> Eye irritant | <input type="checkbox"/> Respiratory irritant | <input type="checkbox"/> Heavier than air | |

4. **Process components & by-products:**
Name: _____ Formula: _____

Hazardous: Yes No
How? _____

Name: _____ Formula: _____
Hazardous: Yes No
How? _____

7. **What in-house provisions have been made to respond to a spill or fire involving these materials?** _____

8. **What special precautions should be taken by first persons responding to an incident at your facility?** _____

9. **List and give locations of rescue and response materials and supplies located at your facility:**

a. Material: _____
Location: _____

b. Material: _____
Location: _____

10. **Give location of Material Safety Data Sheets for hazardous materials on the premises.**

Hazardous Materials Notes

Health District:

County:

Date:

RADIOLOGICAL RESPONSE

The Georgia Radiological Emergency Plan (GA REP) has been developed on a statewide basis as an integral part of the Georgia Emergency Operations Plan (GEOP). The GEOP is an emergency operations plan for all natural and man-made disasters, accidents and incidents including the threat or actualization of conventional or nuclear war. The GA REP serves as the Nuclear/Radiological Incident Annex (Annex F) of the GEOP.

In accordance with the current Governor's Executive Order, the Georgia Department of Natural Resources-Environmental Protection Division (DNR-EPD) as Emergency Support Function (ESF)-10, Hazardous Materials, and the Georgia Emergency Management Agency (GEMA) as ESF-5, Emergency Management, have lead agency responsibility for responding to all radiological emergency situations throughout Georgia. Under the procedure established by this plan, the radiological emergency response team, a component of ESF-10, assesses the radiological conditions at the site of an incident. Based on this assessment, the Governor may declare a state of emergency. Under the statutory authority granted to GEMA, pre-established plans and procedures of state agencies and local government organizations are automatically activated and coordinated by the GEMA State Operations Center (SOC) in Atlanta or appropriate Forward Emergency Operating Center (FEOC) in the vicinity of fixed nuclear facilities or incident site. In the event of a radiological emergency, GEMA (ESF-5) has broad legal authority to take whatever actions are deemed necessary to protect the health and safety of Georgia citizens.

The Georgia Department of Public Health (DPH), Division of Health Protection, Emergency Preparedness and Response (EPR) plan addresses the Public Health response to incidents involving radioactive materials where crisis management personnel are likely to be overwhelmed quickly with mass casualties.

In response to a radiological event, EPR will play a key role in risk communication, population monitoring, disease registry, mental health services, and coordination of medical resources and volunteers. These duties will be carried out in conjunction with partner agencies at the State and Federal levels and will concentrate on supporting local response efforts. It is anticipated that a large portion of the population – both in close proximity to the event and in the surrounding areas – will desire radiological screening and medical consultation following a large-scale radiological event.

Some Assumptions will be that a State of Emergency has, or will be declared. County, District, and State Public Health personnel will be available for response and an adequate number of qualified staff or volunteers will be available to support Reception Center Operations.

What Are The Roles And Responsibilities Of Federal, State, And Local Public Health Agencies?

If a radiation incident occurs in your community, your chief executive officer (the mayor or city or county manager) is responsible for coordinating the overall local response and resources. State and local public health agencies will have many responsibilities, including

- Protecting the public's health and safety.
- Monitoring workers' health and safety.
- Ensuring provision of health and medical services.
- Ensuring safe shelters for the population.
- Ensuring the safety of food and water supplies.
- Coordinating sampling and laboratory analysis of biological and environmental samples.
- Conducting field investigations.
- Monitoring people who may have been contaminated with radioactive materials or exposed to radiation (population monitoring).
- Conducting or assisting in decontamination.
- Developing criteria for entry and operations within the incident site.
- Recommending disease prevention and control measures.
- Recommending management protocols for affected populations or individuals.
- Communicating necessary information to medical providers.
- Communicating situation assessments and required safety measures to the public.
- Assisting law enforcement agencies with the criminal investigation

Local health agencies may call on state health officials, who in turn may request assistance from the federal government. The Nuclear/Radiological Incident Annex of the National Response Plan explains how federal agencies will coordinate a response to nuclear or radiological incidents. Under this annex, HHS and CDC are responsible for coordinating public health aspects of the federal response to any Incident of National Significance involving nuclear or radiological material, including

- Coordinating public health and medical information.
- Convening subject matter experts.
- Assessing medical and public health status and needs.
- Assisting in the establishment of a registry for potentially exposed individuals.
- Performing dose reconstructions and long-term monitoring of populations.
- Evaluating requests for deployment of the Strategic National Stockpile.
- Sending representatives to serve as members of the Federal Advisory Team for Environment, Food, and Health.

These services will be provided to support the affected state or states. As a general rule, during the initial stages of the incident, local and state officials should be prepared to handle the crisis without federal assistance

In the DPH State Radiological Response Plan, Environmental Health Specialists have been identified as staff that **may** be called upon to:

1. Conduct radiological surveys of contaminated individuals
2. Monitor personal decontamination efforts
3. Distribute educational information among victims

Just in time training would be expected regarding the operation of the Public Health District's radiation monitoring equipment. The District Emergency Preparedness Office will be responsible for contacting Environmental Health Specialists and providing reporting locations, if needed. District or State EP will also be responsible for distributing and delivering training for proper operation of the radiation monitoring equipment for Environmental Health Specialists.

INSECT AND RODENT CONTROL STANDARD OPERATING PROCEDURES

1. Identify resources that will be needed to limit the adverse impact of the increased insect and rodent populations after a natural disaster.

Resources should include entomologists to help identify the species involved and provide consultation on their life cycles as well as the preferred control measures. They often can be found at colleges or universities, mosquito control commissions, and pest control companies. Other resources to be located are: ULV fogging equipment, aircraft for aerial application of larvicide, equipment to construct emergency drainage projects along with experienced operators. Epidemiologist experienced in identification and control of insect borne diseases should be included in planning your programs.

Large numbers of rodents will be displaced by rising waters and will seek shelter in houses, barns, schools or any other building or structure that remains above flood level. This creates the need for personnel that are familiar with community wide rodent control procedures. They also should be identified and consulted when planning public health programs relating to rodent control.

2. Press releases and EXAMPLE PUBLIC SERVICE ANNOUNCEMENTS providing information on insect related diseases and preventive measures should be prepared and ready for release before the storm or flood occurs. These releases should also include information on the dangers of insect stings or bites and give recommended treatment information. The medical community should be alerted to possible occurrences of insect borne diseases so that they will consider them a possibility when diagnosing and treating patients.
3. The Georgia Department of Public Health maintains an Emergency Mosquito Surveillance Trailer that can be deployed to areas experiencing an emergency or disaster for surveillance of vector and nuisance mosquito species. **See education section for procedures on requesting this equipment.**

Insect and Rodent Control Notes

Health District:

County:

Date:

**Environmental Health
Rabies Control Program
Current Status**

Health District: _____

County: _____

Date: _____

The last laboratory confirmed case of rabies in each county in the District is listed below:

<i>County</i>	<i>Animal Type</i>	<i>Date</i>

Post exposure rabies treatment in District _____ Unit _____ can be obtained at the following locations.

<i>Name of Facility</i>	<i>Address</i>	<i>Telephone Number</i>

<i>County</i>	<i>Agency</i>	<i>Address</i>	<i>Telephone Number</i>

Consultation on rabies activities is available from:

Georgia Poison Center
Outside Atlanta: 1-800-222-1222
Atlanta: 404-616-9000

Georgia Department of Public Health
Epidemiology and Prevention Branch
404-657-2588 After Hours: 1-866-782-4584

Centers for Disease Control and Prevention
1600 Clifton Road
Atlanta, Georgia
Telephone: 1-800-232-4636

During disaster situations alternative labs and shipping arrangements might be needed.

Rabies Control Notes

Health District:

County:

Date:

**SWIMMING POOLS
STANDARD OPERATING PROCEDURES**

1. Any public swimming pool that has an existing substantial and imminent health hazard shall close to bathers immediately. Items considered being substantial and imminent health hazards include the following:
 1. Disinfectant levels are less than the minimum given in the State or local code; or
 2. The pH is less than the minimum or more than maximum levels allowed in the State or local code; or
 3. The pump, automatic disinfectant equipment or other equipment necessary for continuous filtration and disinfection of the swimming pool, spa or recreational water park attraction is not working; or
 4. The water turbidity is such that the main drain cover or a standard black and white disc laying on the bottom of the deepest portion of the pool cannot be seen; or
 5. Fecal Incidents (note – the local Health Department must be notified); or
 6. Other hazards as determined by the local Health Department.

Signs shall be posted at all entry points to the pool area indicating that the pool is closed to bathers. All gates to the pool area shall be closed and locked. Notice of closure should be reported to the local environmental health department.

2. The following procedures will govern the re-opening of the pool.
 - (a) When power is restored, turn on filter, pumps, and bacteria control devices. Record the date and time on pool operator's log.
 - (b) Allow equipment to operate until the entire pool volume is cycled through the filtering system. This is the pools turnover requirement.

$$\text{Turnover} = \frac{\text{Pool volume in gallons}}{\text{Flow meter reading in GPM X 60}}$$

- (c) Test water for bactericide, pH, and total alkalinity. Record time and results in pool operators log. If these tests indicate that the water is in compliance with the swimming pool regulations, call the local health department to schedule an inspection.
 - (d) If the initial test indicates non-compliance, record the time and results in the pool operator's log. Adjust chemicals as needed and complete another pool turnover. Retest after second turnover is completed.
3. The pool **MUST REMAIN CLOSED** until written approval is granted by a representative of the local Health Department.
4. Swimming pools may be used as an emergency source of water for fire fighting and flushing toilets, but should not be used for bathing or human consumption unless it has been examined by a laboratory and has met the standards for drinking water.
5. Use the Complaint/Incident Report Form to track actions in this program.

Environmental Health Inspection Report Swimming Pools/Recreational Waters

Health District: _____ **County:** _____ **Date:** _____

Site Name: _____ **Time:** _____

Street Address: _____ **City:** _____ **Zip Code:** _____

I. SWIMMING POOL

A. Water Quality (Refer to State or Local pool code, which ever has jurisdiction)

- Disinfectant level _____ ppm
- pH Level _____ (7.2 - 7.8)
- Cyanuric acid level _____ ppm (< 100 ppm)
- Total alkalinity _____ ppm (80 ppm - 120 ppm)
- Water clear (main drain clearly visible)
- Pool clean

B. Safety

- Qualified attendant(s) on duty
- Telephone; emergency numbers posted
- Rules and regulations posted
- Lifesaving apparatus
- First-aid kit

C. Miscellaneous

- Backflow prevention provided
- Operating instructions posted
- Valid operating permit posted. Permit # _____
- Test kit(s)
- Adequate lighting

D. Sanitary Facilities

- Maintained in a sanitary condition

II. RECREATIONAL WATER

A. Bacteriological Quality

- Recent sanitary survey performed
- Results: _____

B. Safety

- Qualified lifeguards
- Lifeguard station with proper safety equipment
- Outer safety limits visibly marked with buoys
- Adequate number of lifeguards
- Lifeguard boat with proper equipment

C. Sanitary Facilities

- Maintained in a sanitary condition

III. COMMENTS: _____

- OK to open facility
- Facility NOT OPEN
- CLOSE facility _____
- Facility OPEN _____

Report received by: _____

Inspector Signature: _____ Date: _____

Swimming Pools/Recreational Waters Notes

Health District:

County:

Date:

**Environmental Health Inspection Report
Daily Activities (Situation Report)**

Health District: _____

County: _____

Date: _____

#1-8 - please fill in the blanks with the applicable number.

1. EMERGENCY FOOD SERVICE:

Feeding sites inspected: _____ Feeding sites closed/suspended: _____
Meals served daily: _____

2. EMERGENCY HOUSING:

Shelters inspected: _____ Total population in shelters: _____

3. WATER SUPPLIES:

Water samples collected: Initial: _____ Rechecks: _____ Positive: _____
Bulk distribution sites: Inspected: _____ Sampled: _____

4. SEWAGE:

Portable toilets inspected: _____ Taken out of service: _____
Service trucks inspected: _____
Septic tanks inspected: New _____ Repaired _____ Hold & pump _____

5. COMPLAINTS INVESTIGATED:

Food: _____ Water: _____ Sewage: _____ Insect: _____ Rodent: _____
Housing: _____ Solid waste: _____ Standing water: _____ Dead animal: _____
Other: _____

6. ANIMAL BITES:

Investigated: _____ Heads tested: _____ Positive: _____
People treated (initial treatment): _____

7. INJURY CONTROL:

Injuries reported: _____ Fatalities reported: _____

8. PUBLIC INFORMATION:

Press releases: _____ Interviews: _____ Newspaper articles: _____

9. SIGNIFICANT PROBLEMS:

10. SIGNIFICANT ACTIONS/RESOLUTIONS:

11. ANTICIPATED PROBLEMS:

12. ASSISTANCE/RESOURCES NEEDED:

13. ACTIONS TAKEN TO MEET NEEDS:

Prepared by: _____

Title: _____

Telephone #: _____

COMMUNICATIONS LOG INSTRUCTIONS

In order for the staff on duty at any site used in the emergency response effort to be able to make the best possible decisions, they must know the status of the operations when they came on duty. The communications log will provide information on activities that have taken place earlier and let them know what request for information or assistance is outstanding and which messages should have a reply coming in.

An entry should be placed in the log for every message sent or received even if the recipient is located in the EOC with the Health Department staff.

The items below will help you complete the log correctly.

- SITE:** This block will identify the location for which the log applies. Be specific so the site can be recognized.
- DATE:** The date should be entered here as follows; mm-dd-yy. A separate page should be used for each day even if all spaces are not used.
- TIME:** The time is to be entered using military time to avoid confusion as to whether the communication occurred before noon or after. For example 1:30 PM would be entered as 13:30.
- TYPE:** Enter the first letter for the type of communications shown. **T**elephone, **R**adio, **F**ax, **E**-Mail, **W**ritten, **O**ral
- TO/FROM:** Place check in box to indicate if message is to or from the person whose name is in the name box.
- NAME:** Place the name of the person, agency or, organization to receive message or from whom the message was received in this box. If known give both person and agency names.
- MESSAGE:** Give a brief synopsis of the message. If it is maintained elsewhere in its entirety indicate location if it is known.
- REPLY:** Place a check in this column if a reply is requested or required in the outgoing communication.
- RECEIVED:** Place the date and time when reply is received in this box. This allows the staff on duty to determine the status of all messages in the log.

Environmental Health
Communications Log

Health District:

County:

<i>Date</i>	<i>Time</i>	<i>Type</i>	<i>To</i>	<i>From</i>	<i>Name</i>	<i>Message</i>	<i>Reply</i>	<i>Received</i>

RESOURCES FILE

The resource file is basically a listing of all the resources in your county/district that you have identified that might be accessed in order to respond effectively to the disaster. It should answer the questions: "Where do I get?, Who has a.....?, Who has information on.....?, and How do you.....?". In other words, it should provide you with the answer to any question that might arise in fulfilling the obligation to protect the health of the people in the disaster area.

To create this file, you need to think about what problems might arise from each type of disaster, flood, hurricane, ice storm, fire, earthquake, hazardous material spill, airplane crash, train wreck, etc. and what you would need to respond effectively. Keep the file in several formats:

1. Computer – several computer terminals in several locations
2. Backup disk – several backup disks stored in several locations
3. Hard copy – several hard copy files stored in several locations

Make sure that numerous individuals are informed about the resource file: its location and how/when it should be used.

Resources include supplies, equipment, manpower, skills, time, and expertise.

In developing the file, contact the person that controls the resource, explain your reason for calling, and ask if he/she would be willing and able to provide assistance if called upon. If possible, get a written statement giving information on what type of resource he/she has and how much he/she can commit to disaster response. These commitments should be updated annually.

Develop a process to include in the file 24-hour contact information for each individual and/or resource.

Although this list is extensive, you will probably think of other supplies, equipment, and people you should add.

When completing this file you should be as thorough as possible since it might be used by people that have come from other areas of the state and are not familiar with local agencies.

RESOURCES FILE ITEMS

Consistency in format is an absolute necessity for this file to be useful and accurate. The format described below will produce a file that allows easy location of the resource desired. This is accomplished by alphabetically sorting the data after it is entered onto the table using the "sort" feature of Microsoft Word. The list below is not all-inclusive, but is provided as a starting point from which you can build a very valuable tool for use in your emergency response activities.

1. **AIRCRAFT** fixed wing and helicopter -- for observation fly over, search and rescue, transportation, aerial application of insecticides.
2. **BUILDING** for relocation of health Department, storage of relief supplies, feeding sites.
3. **COMMUNICATIONS EQUIPMENT** cellular phones, radios, amateur radio operators, fax machine, computer with fax modem.
4. **DATA PROCESSING** computer, copier, fax machine, printer.
5. **EXPERTISE** consultants in technical fields such as radioactive materials, hazardous chemicals, infectious diseases, insect control, toxicology, etc.
6. **FIRE FIGHTING-RESCUE** fire trucks, pumpers, ladder trucks, rescue trucks, foam trucks, diving equipment & divers.
7. **GASOLINE** available for use in state and local Health Department cars and privately owned vehicles for which the Department will pay owners for mileage.
8. **GENERATORS** for emergency lighting and refrigeration for Health Department, for wells, sewage lift stations, treatment plants, and communications equipment. Be sure that generators are compatible with their intended usage.
9. **HOUSING** for relief workers, staff, volunteers, as well as victims.
10. **PUMPS** replacement well pumps, sewage pumps, "mud hog" pumps, high volume water pumps.
11. **LIGHTS** temporary lighting equipment for use at emergency clinics, feeding sites, work areas.
12. **MATERIAL HANDLERS - LABOR** people to unload, load, distribute relief supplies.
13. **BOATS** search & rescue, damage assessment, insect surveillance, transportation of key staff.
14. **MEDICAL EQUIPMENT & SUPPLIES**
 - a. vaccines: tetanus, post exposure rabies, others as determined by clinical services.
 - b. syringes: number and sizes needed to administer the above.
 - c. respiratory equipment: oxygen, masks, tubing, regulators, bag-mask ventilators, and airways.
 - d. program for supplying prescription medications, eyeglasses, hearing aids, replacement batteries, etc.
 - e. disinfectants, Clorox, Betadine, Lysol, etc.

15. EMERGENCY MEDICAL SERVICES

- a. medical response team
- b. dental services,
- c. eye examinations & glasses replacement

16. FOOD

- a. baby food
- b. dietary supplements
- c. tube feeding formulas
- d. animal food - farm animals, pets
- e. commodity foodstuffs
- f. mass feeding supplies

17. PERSONNEL

- a. District Health Director
- b. Emergency Staff (Police, Fire, LEPC, EMA, GEMA, FEMA, Hazmat, etc.)
- c. Bioterrorism
- d. Environmental Health Specialist's
- e. Nurses
- f. Epidemiologists
- g. EMTs
- h. Pharmacists
- i. Physicians
- j. Dentists

18. TRUCKS to meet the need of the situation.

- a. refrigerated: food storage, medicine storage, temporary morgue.
- b. flat bed: to haul equipment dump- debris removal, haul dirt, road repair.
- c. compactor: garbage removal.
- d. claw: load downed trees, clear roads.
- e. fog: apply insecticide, mosquito control
- f. septic tank: pump septic tanks as needed
- g. port-o-let service truck: to empty temporary toilets
- h. boom (crane): debris removal, rescue, clear roads, etc.
- i. tanker, fuel: supply fuel for response equipment, generators.
- j. tanker, food grade: to haul drinking quality water
- k. fire: ladder, pumper, foam, rescue, hazardous materials for fire fighting, clean-up
- l. ambulance: to respond to emergencies
- m. non-emergency medical transport: to move bed-ridden patients
- n. line: repair power lines, communications lines
- o. bucket: rescue, electrical repair, building repair, tree trimming.
- p. vacuum jet unit: clean storm drains
- q. tow truck: remove derelict vehicles
- r. log: haul away usable downed trees
- s. fork lift: unload, store, distribute, relief supplies

19. SECURITY law enforcement agencies, National Guard, private security companies, - to protect people in shelters, tent cities, and damaged homes; protect public and private property.

20. SHELTERS to house evacuees and evacuees with special needs.

Resource File Instructions

The words to be used as key words for sorting are given in **bold type** below.

RESOURCE

This cell will list the resource so that it can be recognized for possible use in the disaster response. Give a general identifier word for the resource and then add further information that classifies it. See the example below.

Example: **Truck, fire pumper**
Truck, fire ladder
Truck, dump

AGENCY

The entry in this cell should be in the same format as that used for the agency cell in the contacts file. Use a major identifier such as the city or county name, and then add the department or agency name. Additional information can be added as needed to adequately describe the listed resource.

Example: **Savannah, City of** **Georgia, State of**
Fire Department **Natural Resources, Department of**
Hazardous Materials Unit **Environmental Protection Division**
Groundwater Program

CONTACT

The name of the person listed in this cell should be someone that knows the location of the resource, its availability, and have the authority to make it available for use if requested. Enter the information as follows: last name, first name, middle initial, and credentials. If a person is a Jr. or III, this should be included to make the name specific to one person.

Example: **Jones, John H., PhD**
Jones, John H. Jr.

LOCATION

This is the normal location of the resource or the operations center where it's based. It might not be at that site after the event, but the contact person will know its location and status.

Example: **Memorial Hospital**
4700 Waters Ave.
Savannah, Ga.

PRE- AND POST EVENT LOCATION PHONE

List ALL telephone numbers for the contact person's pre-event/post-event locations, such as office, home, cellular, and pager. You might have to use them if a disaster occurs after office hours or on the weekend. Ask him/her where they might be after a disaster. This might be a secondary office or the local emergency operations center (EOC).

Example: **Work - (912)651-3100** **EOC - (912)651-3100**
h - (912) 897-4546 **h - (912) 897-4546**
c - (912) 658-1278 **c - (912) 658-1278**
p - (912) 921-6654 **p - (912) 921-6654**

**Environmental Health
Resources Log**

Health District:

County:

<i>Resource</i>	<i>Agency</i>	<i>Contact</i>	<i>Location</i>	<i>Pre-Event Location Phone</i>	<i>Post-Event Location Phone</i>

CONTACTS FILE

The "Contacts" file might well be the one most important file in the emergency operations of the Health Department. It will be used to list and organize information on all agencies, organizations, companies, and people with which the Department has contacts whether on a day-to-day basis, occasionally, or rarely. It will also include listings on those that you identify as possible sources of help in time of disaster.

Consistency in format is an absolute necessity for this file to be useful and accurate. The format described below will produce a file that allows easy location of the resource desired. This is accomplished by alphabetically sorting the data after it is entered onto the table using the "sort" feature of Microsoft Word. The list below is not all-inclusive, but is provided as a starting point from which you can build a very valuable tool for use in your emergency response activities.

- I. All government agencies in your county/district:
 - A. Federal Government
 1. US Public Health Service
 2. US Department of Agriculture
 3. US Coast Guard
 4. NOAA (Weather Service)
 5. US Army Corps. of Engineers
 6. Military Installations
 7. US Park Service
 8. US Penal System
 9. National Guard
 - B. State Government
 1. Department of Agriculture
 2. Department of Public Health
 - a. Environmental Health
 3. Department of Human Services
 - a. Division of Family and Children Services
 - b. Division of Aging Services
 4. Department of Behavioral Health and Developmental Disabilities
 3. Department of Natural Resources
 4. Department of Corrections
 5. Dept of Transportation
 6. Department of Public Safety
 7. University System
 8. Georgia Bureau of Investigation
 9. Department of Community Health
 - a. Healthcare Facility Regulation
 - C. County and City Government
 1. Law Enforcement (Police, Fire, Sheriff)
 2. Elected Officials
 2. Administrative Office (Commissioners, Manager, Administrator)
 3. Department Heads (Public Works, Recreation, Administration, Water and Sewer, etc.)

II. Volunteer Organizations

1. American Red Cross
2. Salvation Army
3. Churches
4. Fraternal Organizations
5. Labor Organizations
6. Civic Clubs

III. Businesses

1. Transportation Companies
2. Commercial Laboratories
3. Warehouse Operators
4. Medical Supply Companies
5. Pharmaceutical Companies
6. Construction Companies
7. Heavy Equipment Companies
8. Pollution Control & Abatement Companies

IV. Individuals

1. Consultants
 - a. Radioactive Materials
 - b. Communicable Diseases
 - c. Engineers (Civil, Structural, Electrical)
2. Special Skills
 - a. Aircraft Pilots
 - b. Boat operators
 - c. Certified Divers
 - d. Search & Rescue
 - e. Amateur Radio Operators

Any other Agency, Organization, Company, Governmental Unit, or Individual that you think might be of some help in responding to and recovering from a disaster should be added to this file.

Any person or company listed should be contacted to obtain the name, title, and telephone number of the contact person. You should discuss the assistance you think they can provide and obtain their commitment to provide it. If possible, get a written verification of the commitment and place it in the appropriate programs response plan.

This file should be updated on a scheduled basis (quarterly recommended).

**Environmental Health
Contacts Log**

Health District:

County:

<i>Agency</i>	<i>Name</i>	<i>Position</i>	<i>Programs</i>	<i>Pre-Event Location Phone</i>	<i>Post-Event Location Phone</i>

DIRECTORY FILE

This file is primarily information contained in the Contacts file and the Resources file which has been merged and sorted alphabetically. This will allow response personnel to locate people by their names and obtain information on their position, programs, resources, etc. and how to get in touch with them.

This format is of great value to response personnel that are from outside the immediate area and would not recognize the names of local officials and be able to associate them with the correct agency or program.

Anyone that you think might be of any assistance in your response activities needs to be included in this file.

Again, consistency is necessary for this file to be sorted accurately. You should enter the last name, first name middle initial, and then any identifiers such as MD, RN, PhD, REHS, etc.

The file should be sorted alphabetically using the name column only with the first key being the last name, the second key the first name, and the third the middle initial.

In addition to this file you should have telephone books and city directories, if available, for every county and community in your district or county.

This file should be updated at least quarterly and printed just before the arrival of a storm or flood with a printed copy of the last quarterly update on hand for use in response to an unexpected disaster such as a tornado or plane crash.

Since you will have this file on a computer disk it will be very easy to make changes as they occur and this is recommended so that you will have accurate data available.

**Environmental Health
Directory Log**

Health District:

County:

<i>Agency</i>	<i>Name</i>	<i>Position</i>	<i>Programs</i>	<i>Pre-Event Location Phone</i>	<i>Post-Event Location Phone</i>

MEDIA CONTACTS

The accessibility to the media in time of a disaster is essential in conducting the activities necessary to protect the health of those affected. It is therefore recommended that you maintain a current listing of all forms of mass media in your county including radio stations, newspapers, TV stations, TV cable companies, etc. This log should include both telephone and fax numbers since most stations and newspapers prefer all materials submitted be written.

Most stations and publications prefer that materials submitted meet the AP conventions on format or some other standard format. Always work through your District PIO before discussing with the media in your area. This will result in better distribution of the information you supply them.

The form following might be used to record the names, locations, type of media, telephone numbers and fax numbers you might need in an emergency.

Information listed in this log should also be entered in the contacts file and the directory file.

PUBLIC SERVICE ANNOUNCEMENTS EXAMPLES

Information that is to be released to the media will be written and contain the following. **It is important to check with the District Public Information Officer before announcements are released to the media.**

1. A release date. For immediate release: June 22, 2003 (plus time, if time is a factor or if it supersedes a previous release)
2. A contact person's name and telephone number, including after hours number.
3. A headline that states the major topic of the release.
4. The first sentence or "lead" should include most, if not all, of the following: who, what, where, when, why, and how.
5. The release should not exceed one page unless there is a good reason.
6. Paragraphs should be limited to 30 words with one idea to a sentence and one or two sentences to a paragraph.
7. If a photo is part of the release it should be noted on the release. The photo should be black and white since most papers rarely use color photos. The photo should be taped to a caption page that supports or clarifies the release. The caption page must give a contact person and telephone number.
8. The release should be double-spaced.
9. Type only on the front of a page NEVER use the back.
10. If a second page is necessary, do not split paragraphs between two pages and always type MORE at the bottom of the page. The second page should have a "slug line" at the top identifying it as the second page along with a key word or phrase.
11. The end of a release is indicated by typing -30- or "#####".

The release should comply with the Associated Press (AP) style conventions. Carefully check the document for misspelled words and grammatical errors. The release should be noted in the communications log giving the time of release and the distribution. The distribution can be given by referring to the attached media list or listing specific reporters, stations, or papers. A copy of the release should be inserted in the log for future reference.

If TV or radio interviews are given they should be entered in the log giving the station, the reporter, date-time, and a short description of the topic discussed. The person giving an interview should be very familiar with the topic being discussed and aware of the impact of the interview and his answers. He should not try to answer any question that he is not certain that his answer is correct. It is not embarrassing to say that "I don't know at this time but I will find out and let you know or have the person with the proper training and information get in touch with you". **VERIFY THAT FOLLOW-UP HAS BEEN MADE**

Press releases to radio stations, TV stations, and newspapers must be faxed or hand delivered. Several examples of press releases follow.

EXAMPLE PUBLIC SERVICE ANNOUNCEMENT

Contact: _____

Time: 30 seconds

For Use Through: _____

FOOD SUPPLIES

With the threatening weather in the tropics, the _____ County Health Department reminds you to keep food safety in mind when you shop for your "hurricane" supplies.

Foods chosen should be those that require no refrigeration and little or no preparation and cooking.

If you plan to use foods that require the addition of water, you should also purchase enough bottled water or store an adequate amount of safe water before the arrival of the storm.

If you have an infant or elderly person in your family that must have formula or a dietary supplement, it should be purchased in "ready to serve" form and the container discarded after the initial use. Therefore, purchasing single service sizes is recommended to reduce waste.

#####

EXAMPLE PUBLIC SERVICE ANNOUNCEMENT

Contact: _____

Time: 20 seconds

For Use Through: _____

PRESCRIPTION MEDICATIONS

When major storms such as hurricanes come ashore, our lives are disrupted.

The _____ County Health Department thinks this can be lessened by proper planning for your health needs in times of disaster.

We recommend that you have a two-week's supply of prescription medications on hand in case you have to evacuate your home and normal supplies will not be available.

Contact your pharmacist or physician to plan for medical needs in such instances.

#####

EXAMPLE PUBLIC SERVICE ANNOUNCEMENT

Contact: _____

Time: 20 seconds

For Use Through: _____

STAY OUT OF FLOOD WATERS

Floodwaters produced by the heavy rains associated with tropical storms and hurricanes could be dangerous. _____, Director of the _____ County Health Department warns residents of areas that are flooded to limit contact with accumulated surface waters.

These waters could be contaminated since they may have come in contact with untreated sewage, animal wastes, decomposing plants, and animals. They may also contain unknown chemicals from manufacturing plants, transportation activities, and agricultural or lawn applications.

If you have come in contact with floodwaters you should take a bath with a bactericidal soap and change to clean dry clothes.

Exposed clothing should not be worn until it has been thoroughly washed and dried. A chlorine-based bleach should be used if it will not damage the fabric.

#####

EXAMPLE PUBLIC SERVICE ANNOUNCEMENT

Release Date: _____

Time: _____

Contact Person: _____

Telephone # (____) _____

CONTROL RATS AFTER FLOOD

Are you moving back into a house that was flooded? Remember that many rats are also looking for a dry place to live. Don't let them use your home as a rodent shelter.

Put away food that could attract rats. Use garbage cans with tight lids. Keep piles of boxes, lumber and other supplies away from the outside walls of your house, or on platforms one foot above the ground. Block holes in your walls and screens and seal the spaces where pipes and drains enter your house.

A health alert from the _____ County Health Department.

#####

EXAMPLE PUBLIC SERVICE ANNOUNCEMENT

Release Date: _____

Time: _____

Contact Person: _____

Telephone # (____) _____

AVOID HAZARDS FROM GAS, ELECTRICITY

If you're moving back into a flood-damaged house, please be careful. Turn off your electricity at the circuit breaker. Have an electrician inspect your wiring and appliances to make sure they're safe. If a propane tank is out of place, don't try to move it. Call your emergency response team for help. Do not light the pilot lights on gas stoves or heaters until you're sure there aren't any leaks. A leak could cause an explosion. Call the gas company if you're in doubt.

A safety alert from the _____ County Health Department.

#####

EXAMPLE PUBLIC SERVICE ANNOUNCEMENT

Release Date: _____

Time: _____

Contact Person: _____

Telephone # (____) _____

MOSQUITO CONTROL AFTER FLOOD

Mosquitoes are a nuisance and can be a health problem. They may get worse after a flood. Spraying poison would kill all insects, including the ones that eat mosquitoes. There is a better solution: Eliminate the standing water where mosquitoes breed.

Don't leave any open containers of water in your house and yard. If you bring water into the house, be sure to use it right away or cover it. Outside, empty the water from tires, buckets, cans and wading pools. Wear insect repellent with DEET and follow directions when applying insect repellent to children.

A health alert from the _____ County Health Department.

#####

EXAMPLE PUBLIC SERVICE ANNOUNCEMENT

Release Date: _____

Time: _____

Contact Person: _____

Telephone # (____) _____

NO SHOTS NECESSARY FOR FLOOD VICTIMS

If you live in a flood damaged area, please be careful. Use clean water for drinking and cooking. Don't eat food that the floodwater has touched. Shots for diseases like typhoid or hepatitis are not necessary. If you have an injury that broke the skin and you don't remember having a tetanus shot within the past five years, go to your doctor or the county health department right away for a tetanus shot.

A health alert from the _____ County Health Department.

#####

EXAMPLE PUBLIC SERVICE ANNOUNCEMENT

Release Date: _____

Time: _____

Contact Person: _____

Telephone # (____) _____

FLOOD CLEANUP: AVOID INFECTION

Cleaning up after the flood? Protect yourself and your family from infections.

Disinfect your walls, floors and furniture. Pay special attention to places where you keep or prepare food, and where small children play. Make sure the detergent you use has a sanitizer that can kill mold. If you don't have a strong detergent, you can use soap and water with one cup of bleach in each gallon of water. Never mix bleach with any other disinfectants or other chemicals.

When you rip out damaged walls and woodwork, wear an appropriate dust mask to minimize breathing mold, asbestos and other dust.

A health alert from the _____ County Health Department.

#####

EXAMPLE PUBLIC SERVICE ANNOUNCEMENT

Release Date: _____

Time: _____

Contact Person: _____

Telephone # (____)_____

BE SURE YOUR WATER IS SAFE TO DRINK

The flood has polluted many wells and water systems in our area. Drink only bottled water or water from wells that have been tested by the county health department and found safe to drink.

If you can't get safe water, you can disinfect the water you have by bringing it to a full rolling boil for one (1) minute. If you can't boil it, add two (2) drops of non-scented household chlorine bleach to each quart of clear water. Add four drops of bleach to each quart of cloudy water. Then, let the water and bleach mixture sit for half an hour before you use it.

A health alert from the _____ County Health Department.

#####

SAFETY HAZARDS

The destructive winds of a hurricane create many hazards that can lead to injuries. Any trip outside calls for extreme care, in order to avoid being hurt.

Falling trees often break power lines and poles causing them to fall to the ground where they have the potential of electrocuting anyone that comes into contact with them. **All wires on the ground should be treated as if they are live; this calls for avoiding them entirely.** Report all downed wires to closest available law enforcement officer or power company employee and keep all other people away until the line has been removed or repaired. Even though a line is not live at one time it may become "hot" at a later time as power is restored to the system or by feedback if an unauthorized generator is connected to any structure in the system. To be safe, **do not touch any wire lying on the ground.**

TO BE SAFE, DO NOT TOUCH ANY WIRE LYING ON THE GROUND.

The fallen trees present another potentially fatal hazard. Many people that do not routinely operate chainsaws undertake the cleanup of their yards and use them to cut up fallen trees. Because the trees were blown over they may still have their roots attached and are very unstable. This could lead unexpected movement and cause the saw to "kickback" causing a serious injury. Other injuries occur when people try to cut limbs while standing on a ladder or other unstable footing. **The use of chainsaws should be limited to those who have proper training and experience to use them safely.**

When shingles are blown off of buildings they often pull out the nails that held them in place. Because of this the ground could be covered with nails that can easily penetrate through shoes and inflict a wound. **If you must walk outside, choose your route carefully so as not to step on nails.**

Animals become scared, disoriented, and often injured in the destructive violence of a hurricane. As the result of this stress they may become aggressive or even vicious. Wildlife is forced from its normal habitat and may move into populated areas seeking refuge from flooding. This includes small mammals such as opossums, raccoons, rabbits, rats, foxes, and coyotes. Many of these serve as reservoirs for diseases including rabies. **All animals should be considered dangerous until observation indicates otherwise. Even household pets that you know should be approached with care.**

Many ground dwelling insects are forced from their homes by rising water and present their own special hazards. Among these are spiders, yellow jackets, scorpions, non-flying wasps, and fire ants. Fire ants survive flooding by clinging together in a ball and floating until they find dry land. They then disperse in their new home in an aggressive mood inflicting painful bites to all who encounter them. **Be aware of insect infestations and take measures to protect yourself, children, and pets.**

During a hurricane or tornado buildings are subjected to tremendous forces by winds often exceeding one hundred miles per hour. Such stresses may completely destroy a building or only weaken it leaving a structure that may collapse at any time. Damaged buildings should be avoided until they have been inspected by someone trained in this area and pronounced safe. Even then, there may be dangers of falling plaster or weakened support structures.

DO NOT ENTER A BUILDING IF YOU DO NOT KNOW THAT IT IS SAFE.

FIELD SAFETY

Strike Team personnel may be exposed to many hazards during the initial hours following the arrival at a disaster scene. The local jurisdiction and State will be focusing on saving lives and many public safety issues may not be immediately addressed. The Team Leader has the primary responsibility to ensure that good safety practices are maintained throughout the operation. Each team member must also recognize and practice safety procedures to ensure their individual as well as the Team's welfare.

CLOTHING AND PROTECTIVE EQUIPMENT

- Always have your PH identification clearly visible at all times.
- Wear laced leather boots with slip-resistant soles.
- Use gloves to protect hands.
- Wear high visibility protective vest.
- Use insect repellent when exposed to insect-occupied environment.
- Use eye protection when in dusty environments.
- Use hearing protection when working near high noise level equipment such as helicopters.

FIRST AID

Prompt first aid should be given for all injuries. First aid kits are available at the Base of Operations and in each of the Team equipment caches.

HEAT STRESS RECOGNITION

Heat stress disorders are divided into four categories. They are:

- **Heat Cramps** — caused by failure to replace salt lost in sweating.
 - Symptoms are painful muscle cramps.
 - Treat by drinking lightly salted water or lemonade, tomato juice, or athletic drinks.
- **Heat Exhaustion** — caused by failure to replace water and salt lost in sweating.
 - Symptoms are weakness, unstable gait or extreme fatigue; wet, clammy skin; headache; nausea, collapse.
 - Treat by drinking lightly salted fluids and rest in a shaded area.

- **Dehydrated Exhaustion** — caused by failure to replace water losses over several days.
 - Symptoms are weight loss and excessive fatigue.
 - Treat by increasing fluid intake and provide rest until body weight is restored.
- **Heat Stroke** — caused by a total collapse of the body's temperature regulating mechanisms.
 - Symptoms are hot, often dry skin; high body temperature (106° F or higher); mental confusion, delirium, loss of consciousness, convulsions.
 - Treat by cooling the victim immediately, either by immersing in cold water or soaking clothing with cold water and fanning to promote cooling. Continue until temperature drops below 102° F. Treat for shock once temperature is lowered.

SUSPECTED HAZARDOUS MATERIALS

Hazardous materials are being encountered with increasing frequency in disaster situations. Hazardous materials may be industrial or agricultural chemicals, explosive substances, military ordnance, drug labs, etc.

- Since many responders to disasters are neither, trained or equipped to identify and deal with hazardous materials, your primary responsibility is to prevent yourself and others from being adversely affected or injured.
- If you encounter what you suspect may be hazardous materials, generally:
 - Stay upwind, uphill, and avoid breathing vapors.
 - Isolate the area.
 - Warn others in the immediate vicinity.
 - If you do not have specific technical expertise to properly respond to the situation, report it to the experts. **Do not get personally involved.**

HAZARD LABELING SYSTEM

Hazardous materials are identified by the Hazard Labeling System. International regulations require that the contents of packages to be transported be labeled. In some cases, there are different labels for interstate and international shipment. The labels are four inches square, with lettering diagonally across the face of the label. These labels are required by the U.S. Department of Transportation for interstate shipment via rail or highway carrier and regulations require that a label must appear on at least two opposing sides or two opposing ends of a package (excluding bottom). Refer to your Emergency Response Guide for identification of label (Team Equipment Cache).

ENVIRONMENTAL HAZARDS

Hypothermia — Hypothermia is a condition of subnormal body temperature caused by exposure to cold and aggravated by numerous factors.

- Hypothermia usually occurs on a cold, wet, windy day with temperatures at or above freezing.
- When working outdoors in cold weather, to prevent hypothermia:
 - Get adequate rest.
 - Eat nutritional supplements between meals.
 - Use proper clothing and a sleeping bag that is wind resistant, maintains body heat, and limits skin exposure.
- Always anticipate bad weather and dress accordingly, or carry warmer clothes with you.
- Understand the effects of cold and wind. Most hypothermia cases develop between 30° F and 50° F.
- Cover the head and neck to prevent heat loss.
- Keep active to maintain the body's metabolism.

POWER LINE HAZARDS

Many types of disaster events result in downed or drooping power lines. Even deactivated transmission and distribution lines may continue to hold charges. When around downed or drooping power lines:

- **DO NOT** drive under power lines with long radio antennas.
- **DO NOT** fuel vehicles under power lines.
- **DO NOT** go near or move downed power lines.
- **DO NOT** approach power lines when standing water is present.

If a power line falls on your vehicle, **DO NOT** leave your vehicle. If for some other life-threatening reason you must leave the vehicle, jump clear, **DO NOT** hang on, and keep feet together and bunny hop away.

Safety is a matter of common sense. Use it and you will keep yourself and other team members out of trouble and get the job done safely

HELICOPTER TRANSPORTATION

Exposure to helicopter operations while on assignment may be utilized while conducting assessment activities. Helicopters are important assets, which require several safety considerations:

- Follow instructions of helicopter personnel at all times.
- Helicopter personnel should provide detailed briefings on safety procedures to all personnel.
- Stay at least 50 feet away from small helicopters and 100 feet away from large helicopters, unless authorized by the pilot or flight crews.
- Always approach or leave aircraft from the front or from the side near the front, in full view of pilot.
- Never approach or leave helicopter where ground is higher than where helicopter is sitting or hovering.
- Unless equipped with eye protection, do not watch landings, takeoffs, or hovering helicopters.
- Hard hats should be worn only if equipped with a chinstrap, otherwise hard hats must be securely carried by passengers.
- Keep safety harness fastened at all times, except when instructed to release it.
- When leaving the helicopter, stoop-walk immediately away to the front or side until at least 30 feet away from the rotors.
- Stay away from tail rotors at all times
- Carry all loose papers, maps etc., securely in hand or enclosed in a bag or briefcase.
- Do not smoke within 50 feet of helicopter, fuel storage, or fueling equipment.
- Never stand directly beneath hovering helicopter unless trained in and performing sling load hookup operations.
- Show wind direction for landing helicopter with flag, dust, or other visual indicator.
- Keep helicopter facilities clear of unauthorized personnel, equipment, and loose objects.

RECOVERY \ MITIGATION

Recovery and mitigation activities in Environmental Health are aimed at returning the population to at least the standard of living before the event and by coordinating corrective activities and planning programs prevent recurring disasters or lessen their impact.

Items to be considered are:

- ❖ Post event evaluation to determine recovery priorities.
- ❖ Communication and coordination with other agencies to assure safe food supply and safe food service.
- ❖ Coordination with other agencies to assure safe, appropriate housing for victims of the disaster.
- ❖ Inter agency cooperation to assure a safe water supply and adequate sewage disposal.
- ❖ Proper location, construction, and protection of wells to prevent flooding and contamination.
- ❖ Prohibition of constructing homes in identified flood plains.
- ❖ Thorough evaluation of proposed home sites to identify potential hazards (old landfills, buried fuel tanks, etc.)
- ❖ Active participation in community planning, zoning, and code development and enforcement.

Mitigation activities are not only reactions to an event but are also proactive elements in preparedness for future events that address specific identified problems.

OUTDOOR AIR QUALITY

The Georgia Department of Natural Resources, Environmental Protection Division, Air Protection Branch is the lead agency regarding air quality. The mission of the EPD is to protect and restore Georgia's environment. This is achieved by the Air Protection Branch mission of protecting Georgia's air quality through regulation of emissions from industrial and mobile sources through Ambient Monitoring, Industrial Source Monitoring, Mobile and Area Sources, Planning and Support, Stationary Source Compliance, and Stationary Source Permitting.

The Georgia Department of Public Health (DPH), Environmental Health Section would act in a support role to the EPD during an event. The primary involvement of EH would be to assist with risk communication and health education, complaint referral, and Source permitting referral.

EPD maintains a 24 hour emergency hotline in the event of a disaster. DPH has contact information for all EPD related situations. The Georgia Emergency Management Agency (GEMA) will coordinate large scale emergencies and bring the appropriate Emergency Support Functions into the State Operations Center where DPH and EPD will communicate and provide assistance as requested.

This cooperation was exhibited during the 2008 wildfires in South Georgia. Public Health provided risk communication and educational messages to the public who were exposed to smoke. PH monitored ambient monitoring stations for particulate matter and discussed the data with the Air Protection Branch.

EDUCATION SECTION

Hand Washing Signs

Wash Your Hands

After a disaster, staying clean can be hard to do. You may not have running water. But staying clean helps you stay healthy.

Things you can do to stay clean and healthy

- Wash your hands with soap and clean water. If you don't have soap and water, you can use hand cleaners with alcohol in them.
- Wash your hands many times each day.



Times to wash your hands are

BEFORE

- making food
- eating
- touching a sick person
- touching a cut, sore, or wound.

AFTER

- using the bathroom
- blowing your nose, coughing, or sneezing
- touching things that may carry germs, like
 - diapers or a child who has used the toilet
 - food that is not cooked (raw food)
 - animals or animal waste
 - trash
 - things touched by flood water
 - a sick person
 - cuts, sores, and wounds.



Recommendations from the Centers for Disease Control and Prevention

Food and Water Safety



DISASTER SAFETY

Keep Food and Water Safe after a Natural Disaster or Power Outage

Food

Food may not be safe to eat during and after an emergency. Safe water for drinking, cooking, and personal hygiene includes bottled, boiled, or treated water. Your state or local health department can make specific recommendations for boiling or treating water in your area.

Identify and throw away food that may not be safe to eat.

- Throw away food that may have come in contact with flood or storm water.
- Throw away food that has an unusual odor, color, or texture.
- Throw away perishable foods (including meat, poultry, fish, eggs and leftovers) that have been above 40 degrees Fahrenheit (F) for 2 hours or more.
- Thawed food that contains ice crystals or is 40 degrees F or below can be refrozen or cooked.
- Throw away canned foods that are bulging, opened, or damaged.
- Food containers with screw-caps, snap-lids, crimped caps (soda pop bottles), twist caps, flip tops, snap-open, and home canned foods should be discarded if they have come into contact with floodwater because they cannot be disinfected.
- If cans have come in contact with floodwater or storm water, remove the labels, wash the cans, and dip them in a solution of 1 cup of bleach in 5 gallons of water. Relabel the cans with a marker.
- Do not use contaminated water to wash dishes, brush your teeth, wash and prepare food, wash your hands, make ice, or make baby formula.

Store food safely.

- While the power is out, keep the refrigerator and freezer doors closed as much as possible.
- Add block ice or dry ice to your refrigerator if the electricity is expected to be off longer than 4 hours. Wear heavy gloves when handling ice.

Feeding Infants and Young Children

- Breastfed infants should continue breastfeeding. For formula-fed infants, use ready-to-feed formula if possible. If using ready-to-feed formula is not possible, it is best to use bottled water to prepare powdered or concentrated formula. If bottled water is not available, use boiled water. Use treated water to prepare formula only if you do not have bottled or boiled water.
 - If you prepare formula with boiled water, let the formula cool sufficiently before giving it to an infant.
 - Clean feeding bottles and nipples with bottled, boiled, or treated water before each use.
 - Wash your hands before preparing formula and before feeding an infant. You can use alcohol-based hand sanitizer for washing your hands if the water supply is limited.

Keep Food and Water Safe after a Natural Disaster or Power Outage (continued from previous page)

Related Resources:

- **USDA Meat and Poultry Hotline: 1-888-MPHotline.**
Available for consumers questions and concerns about food safety.
- [USDA Alert: Keeping Food Safe During Flooding and Power Outages](http://www.usda.gov/2005/08/0340.xml)
(<http://www.usda.gov/2005/08/0340.xml>)
USDA Food Safety Information related to Hurricane Katrina
- [Hand Hygiene in Emergency Situations](http://www.bt.cdc.gov/disasters/hurricanes/handwashing.asp)
(<http://www.bt.cdc.gov/disasters/hurricanes/handwashing.asp>)
When to wash your hands & how to do it without running water...
- [Keeping Food Safe in an Emergency, U.S. Department of Agriculture](http://www.fsis.usda.gov/Fact_Sheets/keeping_food_Safe_during_an_emergency/index.asp)
(http://www.fsis.usda.gov/Fact_Sheets/keeping_food_Safe_during_an_emergency/index.asp)
General fact sheet and FAQs on food and water safety including guidance on when to discard perishable foods
- [www.foodsafety.gov - Consumer Advice: Disaster Assistance with Food](http://www.foodsafety.gov/%7Efsg/fsgdisas.html)
(<http://www.foodsafety.gov/%7Efsg/fsgdisas.html>)
Provides resources on food safety related to fires, floods, hurricanes, power outages, etc.
- [Food Safety Information for Hurricane Aftermath, FDA](http://www.cfsan.fda.gov/~dms/fsdisas.html)
(<http://www.cfsan.fda.gov/~dms/fsdisas.html>)
Tips to help people protect their health & food supply
- [Food Safety Office, CDC](http://www.cdc.gov/foodsafety/) (<http://www.cdc.gov/foodsafety/>)
Comprehensive food safety information
- [Being Prepared, American Red Cross](http://www.redcross.org/services/disaster/beprepared/) (<http://www.redcross.org/services/disaster/beprepared/>)
Comprehensive site on preparing for emergencies including power outages

Water

Water may not be safe to drink, clean with, or bathe in after an emergency such as a hurricane or flood. During and after a disaster, water can become contaminated with microorganisms, such as bacteria, sewage, agricultural or industrial waste, chemicals, and other substances that can cause illness or death. This fact sheet offers the following guidance to help you make sure water is safe to use:

- Listen to and follow public announcements. Local authorities will tell you if tap water is safe to drink or to use for cooking or bathing. If the water is not safe to use, follow local instructions to use bottled water or to boil or disinfect water for cooking, cleaning, or bathing.
- Use only bottled, boiled, or treated water for drinking (however, see guidance in the Food section for infants), cooking or preparing food, washing dishes, cleaning, brushing your teeth, washing your hands, making ice, and bathing until your water supply is tested and found safe. If your water supply is limited, you can use alcohol-based hand sanitizer for washing your hands.
- If you use bottled water, be sure it came from a safe source. If you do not know that the water came from a safe source, you should boil or treat it before you use it.

Keep Food and Water Safe after a Natural Disaster or Power Outage

(continued from previous page)

- Boiling water, when practical, is the preferred way to kill harmful bacteria and parasites. Bringing water to a rolling boil for 1 minute will kill most organisms. Boiling will not remove chemical contaminants. If you suspect or are informed that water is contaminated with chemicals, seek another source of water, such as bottled water.
- If you can't boil water, you can treat water with chlorine tablets, iodine tablets, or unscented household chlorine bleach (5.25% sodium hypochlorite). If you use chlorine tablets or iodine tablets, follow the directions that come with the tablets. If you use household chlorine bleach, add 1/8 teaspoon (~0.75 milliliter [mL]) of bleach per gallon of water if the water is clear. For cloudy water, add 1/4 teaspoon (~1.50 mL) of bleach per gallon. Mix the solution thoroughly and let it stand for about 30 minutes before using it. Treating water with chlorine tablets, iodine tablets, or liquid bleach will not kill many parasitic organisms. Boiling is the best way to kill these organisms.
- Do not rely on water disinfection methods or devices that have not been recommended or approved by local health authorities. Contact your local health department for advice about water treatment products that are being advertised.
- Use water storage tanks and other types of containers with caution. For example, fire truck storage tanks and previously used cans or bottles may be contaminated with microbes or chemicals. Water containers should be thoroughly cleaned, then rinsed with a bleach solution before use.
 - Mix soap and clean water in container. Shake or stir to clean inside of container, then rinse.
 - For gallon- or liter-sized containers, add approximately 1 teaspoon (4.9 mL) household bleach (5.25%) with 1 cup (240 mL) water to make a bleach solution.
 - Cover the container and shake the bleach solution thoroughly, allowing it to contact all inside surfaces. Cover and let stand for 30 minutes, then rinse with clean water.
- Flooded, private water wells will need to be tested and disinfected after flood waters recede. If you suspect that your well may be contaminated, contact your local or state health department or agriculture extension agent for specific advice. See [Disinfecting Wells After an Emergency](http://www.bt.cdc.gov/disasters/wellsdisinfect.asp) (<http://www.bt.cdc.gov/disasters/wellsdisinfect.asp>) for general instructions.
- Practice basic hygiene. Wash your hands with soap and bottled water or water that has been boiled or disinfected. Wash your hands before preparing food or eating, after toilet use, after participating in clean-up activities, and after handling articles contaminated with floodwater or sewage. Use an alcohol-based hand sanitizer to wash your hands if you have a limited supply of clean water.

Related Resources

- [Cleaning and Sanitizing With Bleach After an Emergency](http://www.bt.cdc.gov/disasters/bleach.asp) (<http://www.bt.cdc.gov/disasters/bleach.asp>)
- [Disinfecting Wells After an Emergency](http://www.bt.cdc.gov/disasters/wellsdisinfect.asp) (<http://www.bt.cdc.gov/disasters/wellsdisinfect.asp>)
- [Floods](http://www.bt.cdc.gov/disasters/floods/) (<http://www.bt.cdc.gov/disasters/floods/>)
- [Guidelines for the Management of Acute Diarrhea \(for Healthcare Providers\)](http://www.bt.cdc.gov/disasters/hurricanes/dguidelines.asp) (<http://www.bt.cdc.gov/disasters/hurricanes/dguidelines.asp>)
Increased incidence of acute diarrhea may occur in post-disaster situations where access to electricity, clean water, & sanitary facilities are limited...
- [Hand Hygiene in Emergency Situations](http://www.bt.cdc.gov/disasters/hurricanes/handwashing.asp) (<http://www.bt.cdc.gov/disasters/hurricanes/handwashing.asp>)
When to wash your hands & how to do it without running water...

Monitor your radio or television for up-to-date emergency information.

For more information, visit <http://emergency.cdc.gov/disasters/>, or call CDC at 800-CDC-INFO (English and Spanish) or 888-232-6348 (TTY).

July 2, 2008

Page 3 of 3

DEPARTMENT OF HEALTH AND HUMAN SERVICES
CENTERS FOR DISEASE CONTROL AND PREVENTION
SAFER • HEALTHIER • PEOPLE™

General Health Guidance for Flood Hazards

1) The city's sewer treatment plant was flooded out, which has caused a huge dump of raw sewage to spill into the Chattahoochee River. What are the threats to public health when this happens?

Untreated sewage carries dangerous bacteria, viruses and parasites. Ingested, it can cause stomach and intestinal diseases; if skin is exposed for too long, irritations and infections are possible. The public should avoid flood waters.

2) What can people do to protect themselves? Do they need to boil all drinking water, what about washing their hands from the tap?

The local water authorities are monitoring public water systems and will give public notification if the water supply has been compromised and may be contaminated. The public should watch and listen to local radio and news for updated boil water advisories; the notices give the reason for its issuance and corrective actions to be taken. If individuals come into contact with flood water, washing with uncontaminated water or using a hand sanitizer is recommended.

3) Are there other public health issues when a situation like this arises?

After the boil advisory has been lifted, the affected public should be aware that they must flush the plumbing in their homes to remove any contaminated water before they begin use. Individual wells should be sampled and disinfected, if necessary. Due to saturated soil conditions, septic tank systems may temporarily malfunction requiring homeowners to conserve water use.

4) Are there other health issues that can arise from flood waters?

Flood waters may be fast moving and hide many entrapment hazards. Flash floods are a leading cause of deaths by drowning. There may also be electrical and fire hazards associated with electrical circuits and failing equipment. Additional information can be found at www.gema.ga.gov

What about a flooded home or basement. Is mold and mildew major concerns?

When excessive moisture or water accumulates indoors, mold growth will often occur, particularly if the moisture problem remains un-addressed. There is no practical way to eliminate all molds and mold spores in the indoor environment; the way to control indoor mold growth is to control moisture. Water must be removed as soon as possible and air flow increased. Certain items (such as carpet and fabrics) that are beyond repair should be disposed of. Semi-porous materials like plasterboards need to be evaluated whether they should be disposed of or if they can still be restored with a simple cleanup. Severe damage or long periods of saturation will require more comprehensive and more aggressive clean up.

Should people wear masks and gloves when removing damaged items or cleaning out flooded areas? What else can be done?

Potential health effects and symptoms associated with mold exposures include allergic reactions, asthma, and other respiratory complaints. Flooded areas may also have bacterial and chemical contamination. A person doing cleanup work should minimally wear a N-95 rated mask, gloves, boots and possibly goggles to protect themselves against both biological and chemical hazards. If the damage is extensive a professional should be consulted. Additional information can be found at

<http://www.epa.gov/mold/index.html>. and www.cdc.gov.

**FACT SHEET****After a Hurricane or Flood: Cleanup of Flood Water**

When returning to your home after a hurricane or flood, be aware that flood water may contain sewage. Protect yourself and your family by following these steps:

Inside the Home

- Keep children and pets out of the affected area until cleanup has been completed.
- Wear rubber boots, rubber gloves, and goggles during cleanup of affected area.
- Remove and discard items that cannot be washed and disinfected (such as, mattresses, carpeting, carpet padding, rugs, upholstered furniture, cosmetics, stuffed animals, baby toys, pillows, foam-rubber items, books, wall coverings, and most paper products).
- Remove and discard drywall and insulation that has been contaminated with sewage or flood waters.
- Thoroughly clean all hard surfaces (such as flooring, concrete, molding, wood and metal furniture, countertops, appliances, sinks, and other plumbing fixtures) with hot water and laundry or dish detergent.
- Help the drying process by using fans, air conditioning units, and dehumidifiers.
- After completing the cleanup, wash your hands with soap and water. Use water that has been boiled for 1 minute (allow the water to cool before washing your hands).
 - Or you may use water that has been disinfected for personal hygiene use (solution of $\frac{1}{8}$ teaspoon [~ 0.75 milliliters] of household bleach per 1 gallon of water). Let it stand for 30 minutes. If the water is cloudy, use solution of $\frac{1}{4}$ teaspoon (~ 1.5 milliliters) of household bleach per 1 gallon of water.
- Wash all clothes worn during the cleanup in hot water and detergent. These clothes should be washed separately from uncontaminated clothes and linens.
- Wash clothes contaminated with flood or sewage water in hot water and detergent. It is recommended that a laundromat be used for washing large quantities of clothes and linens until your onsite waste-water system has been professionally inspected and serviced.
- Seek immediate medical attention if you become injured or ill.

Outside the Home

- Keep children and pets out of the affected area until cleanup has been completed.
- Wear rubber boots, rubber gloves, and goggles during cleanup of affected area.
- Have your onsite waste-water system professionally inspected and serviced if you suspect damage.
- Wash all clothes worn during the cleanup in hot water and detergent. These clothes should be washed separately from uncontaminated clothes and linens.
- After completing the cleanup, wash your hands with soap and water. Use water that has been boiled for 1 minute (allow the water to cool before washing your hands).
 - Or you may use water that has been disinfected for personal hygiene use (solution of $\frac{1}{8}$ teaspoon [~ 0.75 milliliters] of household bleach per 1 gallon of water). Let it stand for 30 minutes. If the water is cloudy, use solution of $\frac{1}{4}$ teaspoon (~ 1.5 milliliters) of household bleach per 1 gallon of water.
- Seek immediate medical attention if you become injured or ill.

The information in this fact sheet is general in nature and is not intended to be used as a substitute for professional advice. For more information, please contact your local health department.

For more information, visit emergency.cdc.gov
or call CDC at 800-CDC-INFO (English and Spanish) or 888-232-6348 (TTY).

July 2, 2008

Page 1 of 1



Cleaning and Sanitizing With Bleach after an Emergency

Safety Tips

Use regular unscented 5.25% household bleach. Read and follow the safety instructions on the bleach container's label. Never mix bleach with ammonia or any other cleaner. Wear rubber boots, rubber gloves, and eye protection. Try not to breathe bleach fumes. Open windows and doors to get fresh air.

Cleaning Recommendations

The amount of bleach to mix with water depends on what you are cleaning or sanitizing. The following chart describes some items or surfaces that should and can be cleaned, the amount of bleach to mix with water, and cleaning steps for specific purposes.

Area or Item to be Cleaned	Amount of Bleach and Water to Mix		Cleaning Steps
	Bleach Amount	Water Amount	
Sanitize Drinking Water			
Clear drinking water	1/8 teaspoon (~0.75 mL)	1 gallon	1. Mix 1/8 teaspoon (~0.75 mL) bleach per 1 gallon water. 2. Add it to water. 3. Let it stand for about 30 minutes before using it. For more information see: http://www.bt.cdc.gov/disasters/foodwater.asp
Cloudy drinking water	1/4 teaspoon (~1.5 mL)	1 gallon	1. Mix 1/4 teaspoon (~1.5 mL) bleach per 1 gallon water. 2. Add it to water. 3. Let it stand for about 30 minutes before using it. For more information see: http://www.bt.cdc.gov/disasters/foodwater.asp

Cleaning and Sanitizing With Bleach after an Emergency
(continued from previous page)

Area or Item to be Cleaned	Amount of Bleach and Water to Mix		Cleaning Steps
	Bleach Amount	Water Amount	
Water storage containers (Examples: used cans or bottles)	1 teaspoon (4.9 mL)	1 cup (240 mL)	<ol style="list-style-type: none"> Mix soap and clean water in container. Shake or stir to clean inside of container. Rinse container. Mix 1 teaspoon (4.9 mL) bleach per 1 cup (240 mL) water and pour it in the container. Cover the container and shake so the solution touches all inside surfaces. Cover and let stand for 30 minutes. Rinse with clean water. For more information see: http://www.bt.cdc.gov/disasters/foodwater.asp
Clean and Sanitize Food Cans and Surfaces			
Food-contact surfaces that may have touched floodwater [Examples: countertops, plates] Note: Throw away wooden cutting boards, baby bottle nipples, and pacifiers	1 teaspoon (4.9 mL)	1 gallon	<ol style="list-style-type: none"> Wash with soap and warm, clean water. Rinse with clean water. Sanitize using a mixture of 1 teaspoon (4.9 mL) of bleach per gallon of clean water. Allow to air dry. For more information see: http://www.bt.cdc.gov/disasters/foodwater.asp

Cleaning and Sanitizing With Bleach after an Emergency
(continued from previous page)

Area or Item to be Cleaned	Amount of Bleach and Water to Mix		Cleaning Steps
	Bleach Amount	Water Amount	
Food cans that are not bulging, open, or damaged	1 cup (240 mL)	5 gallons	<ol style="list-style-type: none"> 1. Remove can labels. 2. Wash cans with soap and clean water. 3. Dip cans in mixture of 1 cup (240 mL) of bleach per 5 gallons of water. 4. Relabel cans with a marker. For more information see: http://www.bt.cdc.gov/disasters/foodwater.asp
Clean and Sanitize Other Household Surfaces and Items			
Surfaces that do not soak up water and that may have touched floodwater [Examples: floors, stoves, sinks, certain toys, countertops, flatware, plates, and tools]	1 cup (240 mL)	5 gallons	<ol style="list-style-type: none"> 1. Clean surface with soap and clean water. 2. Disinfect with a mixture of 1 cup (240 mL) of bleach to 5 gallons of water. For more information see: http://www.bt.cdc.gov/disasters/floods/after.asp#cleanup <ol style="list-style-type: none"> 3. Allow to air dry.
Clean Mold Growth Off Hard Surfaces			
Mold growth on hard surfaces [Examples: floors, stoves, sinks, certain toys, countertops, flatware, plates, and tools]	1 cup (240 mL)	1 gallon	<ol style="list-style-type: none"> 1. Mix 1 cup (240 mL) of bleach in 1 gallon of water. 2. Wash the item with the bleach mixture. 3. If the surface of the item is rough, scrub the surface with a stiff brush. 4. Rinse the item with clean water. 5. Dry the item or leave it out to dry. For more information see: http://www.bt.cdc.gov/disasters/mold/protect.asp

For more information, visit emergency.cdc.gov/disasters, or call CDC at 800-CDC-INFO (English and Spanish) or 888-232-6348 (TTY).

Minimum Number of Portable Sanitation Units at Construction Sites

Number of Workers*	Minimum Number of Units If Serviced Once a Week**
20 or less	1
20 or more	1 Toilet and Urinal per 40 Workers
200 or more	1 Toilet and Urinal per 50 Workers

29 CFR 1926.51 OSHA Regulations for Toilets at Construction Sites

* The number of portable sanitation units required shall be determined by the maximum number of workers present on a regular shift.

** "Servicing" refers to the emptying of waste and the cleaning of the portable sanitation unit.

Portable Sanitation Units for Special Events Planning*

PEAK CROWD NUMBER OF PEOPLE	MINIMUM NUMBER OF UNITS REQUIRED FOR EVENTS – 2 HOURS OR LESS*
1-500	2
1,000	3
2,000	5
3,000	7
4,000	10
5,000	12
6,000	14
7,000	17
8,000	20
10,000	25
12,500	28
15,000	30
17,500	35
20,000	38
25,000	42
30,000	44
40,000	48
50,000	50
75,000	75
100,000	100

*Table based on units being serviced daily

- Determine the appropriate portable sanitation units needed from the table above.
- For each sewerer toilet available onsite, subtract 1 from the previously calculated number.
- If alcoholic beverages are to be served, add 25% to the base number.
- If toilets are to be serviced more than once per day, subtract 25% from the base number.
- For peak crowd numbers that fall between chart numbers, round up to the next base number.
- For events lasting more than 2 hours, double the minimum number of required units every 2 hours of the event (i.e. An 6 hour event with a group size of 400; requires 2 portable sanitation units for the first 2 hours, 4 portable sanitation units for the next 4 hours and a total of 8 portable sanitation units for the 6 hour event).
- Additional units may be required as deemed necessary by the Health Authority.

Mosquito Surveillance Trailer

**EMERGENCY MOSQUITO SURVEILLANCE TRAILER
USE PROTOCOLS**



Georgia Department of Public Health

Sample Memo

TO: GDPH Emergency Preparedness Coordinator

SUBJECT: Emergency Mosquito Surveillance Trailer Loan Request

1. NAME OF AGENCY REQUESTING SUPPORT:
2. NAME OF AUTHORIZED REPRESENTATIVE:
3. CONTACT INFO (phone, email, cell, etc):
4. BRIEF DESCRIPTION OF EVENT*:
5. LOCAL RESOURCES DEPLOYED:
6. DESCRIPTION OF NEED (personnel, equipment, materials, and supplies):

7. ESTIMATED LENGTH OF TIME TRAILER IS NEEDED:
8. LOCATION OF STAGING AREA:
9. REQUESTED DATE, TIME AND SITE FOR DELIVERY/COLLECTION OF TRAILER AND SUPPLIES:

SIGNATURE OF AUTHORIZED REPRESENTATIVE:

DATE:

*If this is for a training, please include estimated number of participants and attach a training announcement and agenda or training objectives. If to be deployed to a disaster area, please attach the declaration of emergency. Fax this request and accompanying materials either to GDPH Medical Entomologist at 404-657-2604 (training event) or the GDPH EOC (disaster event) at 404-657-0602 and also to 404-463-2733 to the attention of the Public Health Emergency Preparedness Coordinator.

Environmental Assessment Guide

PLEASE NOTE THAT THIS IS NOT A ROUTINE INSPECTION.

Steps involved in conducting an Environmental Assessment

1. Plan an onsite investigation
 - Identify the persons responsible for operating and managing the implicated facility before visiting the establishment
 - Consult with your Epidemiologist on relevant information about the outbreak before you conduct an Environmental Assessment
 - Alert lab personnel prior to your visit and get suggestions for samples and specimens if needed to be collected
 - Coordinate with the person who has regulatory responsibilities for the establishment under investigation.
 - Assemble your equipment that you may need for your field investigation including sampling, inspection and supportive equipment.
 - Plan to stay in the establishment to evaluate all suspicious processes.

2. Manager interviews
 - State the intent of your visit
 - Attempt to create a spirit of cooperation
 - Get menus, recipes information about the products prepared, product flow names of persons responsible for particular operations and other relevant records. Record information on APPENDIX 1
 - Draw a flow diagram of operations on a copy of APPENDIX 2.
 - Review policies related to employee health, food safety and sanitation.

3. Facility walk through
 - Take a preliminary look at the entire operation to observe conditions that may have contributed to the outbreak.
 - If appropriate, take relevant measurements of critical operations.
 - Obtain samples of suspect foods if available before they are discarded.
 - Accompany workers on a walk through the processing steps for suspect foods from receiving to service.
 - Modify your flow diagram as you conduct your walk through and take notes.
 - Review monitoring records if available

4. Food worker interviews

- Interview all persons separately who were directly involved in preparing the suspect foods.
- Ask questions in a sequence to reveal the flow of suspect foods.
- Get the worker's accounts of the manner by which suspect foods were prepared
- Review the operational manual for procedures that may have led to contamination, proliferation or survival of likely etiologic agents
- Be alert for inconsistencies in accounts of different food workers.
- Modify your flow diagram if required
- Be persistent until logical accounts are obtained.

5. Observe operations

- Investigate sources, receiving, storing preparing cooking handling after if cooking, hot holding, cooling reheating and serving foods.
Specifically observe the following:
 - a) Evaluate the manner of receiving the suspect foods (temperature control, approved source, packaging).
 - b) Evaluate the manner of storage of suspect foods.
 - c) Evaluate the possibilities of cross contamination from worker's hands, gloves, cleaning aids, and from equipment.
 - d) Evaluate the hygienic practices including handwashing of persons who prepare the suspect foods.
 - e) Evaluate the effectiveness of cleaning and sanitizing utensils and equipment.
 - f) Evaluate the procedures used for thawing frozen foods if applicable
 - g) Measure product temperatures during storage, processing and record time sequences of operations.
 - h) Measure temperature of suspect foods during or at the completion of heat processing or reheating.
 - i) Verify the calibration of establishment's time and temperature measuring devices.
 - j) Evaluate the rate at which suspect foods cool during storage at room temperature and in other cooling devices. Plot time and temperature curves for the suspect foods if applicable.
 - k) Measure the pH of foods if applicable
 - l) Measure the Aw of foods if applicable.
- If applicable, investigate phases of transporting delivery storing and retailing.
- Revise the flow diagram.
- Note additional observations or record data as applicable.
- Observe the likely hood of all contributory factors in the operation of suspect food. Refer to list of contributory factors on APPENDIX 3

APPENDIX 1: DETAILS OF SUSPECT FOOD
(NOTE: COMPLETE APPENDIX 1 FOR EACH SINGLE SUSPECT FOOD)

Date: _____ (mm/dd/yyyy)
Time: _____ (am/pm)

Place the suspect food was prepared:
Name of the food service establishment: _____
Location: _____
Person in charge: _____

Information on the suspect food:

Name _____ Quantity: _____ lbs
Implicated _____ Yes/No
Suspect _____ Yes/No
Multi -Ingredients: Yes/No (circle one)
If yes, list the ingredients: _____

Internal temperature of the suspect food at time of environmental assessment _____ °F
Leftover samples available: _____ yes/no
If yes, then are the samples taken: _____ yes/no (choose one)
Describe what were taken

If no, state the reason?

Date when the suspect food was prepared: _____(mm/dd/yyyy)

Time of when the suspect food was prepared: _____(am/pm)

Who were involved in the preparation of the suspect food?

Were there any unusual events that occurred at the time of food preparation?
(if the place was busy, food worker ill, shortage of staff, malfunctioning equipment
(mechanical dishwasher) etc). If so, please describe

Was the suspect food transported to the event where it was eaten /prepared on site
where the event occurred? Circle one

If it was transported to the event where it was eaten, then how was it transported?

Otherwise, if prepared onsite where the event occurred was it temperature controlled for
food safety after preparation before service? Yes/No

If yes, how was the suspect food temperature controlled?

If hot held before service, then at what temperature: _____°F

If cold held before service, then at what temperature: _____°F

If No, then record the internal temperature of the leftover suspect food at the time of the
assessment _____°F

Note: Some of the above information may have to be collected from food worker
interviews if an environmental assessment is not done at the time when the outbreak
occurred.

APPENDIX 2: FLOW DIAGRAM OF SUSPECT FOOD

Insert internal temperature, and appropriate symbol as listed in the table at each steps in the operation of suspect food.

Potato salad example:

Ingredients: Potatoes, mayonnaise, other ingredients

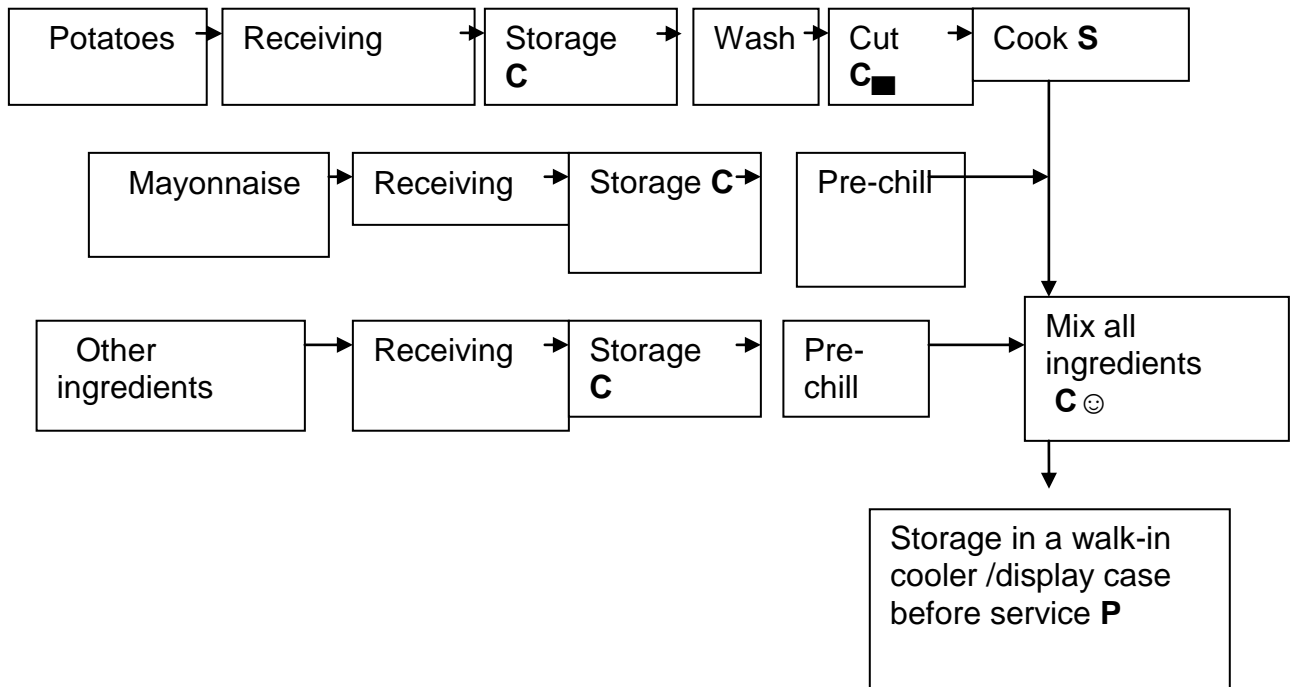

S	SURVIVE
P	PROLIFERATE
C	OTHER TYPES OF CONTAMINATION
C▲	RAW PRODUCT CONTAMINATED
C■	EQUIPMENT CONTAMINATED
C☺	PERSON CONTAMINATED

APPENDIX 3: CONTRIBUTING FACTORS TO THE OUTBREAK

CONTAMINATION (C)

- Toxic substance part of tissue
- Poisonous substance intentionally added
- Poisonous or physical substance accidentally added
- Addition of excess quantities of ingredients under these situations are toxic
- Toxic container or pipelines
- Contaminated raw products eaten
- Raw product contaminated by pathogens from animal or environment
- Obtaining foods from polluted sources
- Cross contamination from raw ingredient of animal origin
- Bare-hand contact by worker
- Inadequate cleaning or processing /preparation equipment/utensil
- Handling by intestinal carrier
- Storage in contaminated environment
- Other source of contamination

PROLIFERATION (P)

- Allowing foods to remain at room temperature
- Inadequate cold holding
- Slow cooling
- Preparing foods a half day or more before serving
- Insufficient time or temperature during hot holding
- Prolonged storage for several weeks
- Insufficient acidification
- Insufficient low aw
- Inadequate thawing
- Anaerobic packing /modified atmosphere
- Inadequate fermentation
- Other

SURVIVAL(S)

- Insufficient time or temperature during cooking/heat processing
- Insufficient time or temperature during reheating
- Inadequate acidification
- Inadequate thawing
- Other

Food and Water Related Illness Complaint Form

Fax Completed form to the Georgia DHR Environmental Health Branch (404) 657-6516

Interviewer: _____

Date of Interview: _____

Name: _____
 Street _____ County _____ Health District _____
 City/State/Zip _____ Occupation/Grade _____
 Phone # _____ Work/Childcare/School _____

Date of Illness Onset: ____ / ____ / ____ Mo Day Year	Numbers of:	0-10 yrs	11-18yrs	19-65yrs	>65yrs
	Persons ill:				
	Visits to Doctor:				
	Hospitalizations:				

Illness History (Check symptoms that apply):

Diarrhea (≥3 stools/day): ____ Nausea: ____ Fever: ____ Vomiting: ____
 Visible blood in stools: ____ Cramps: ____ Rash: ____ Eye Infections: ____
 Ear Infections: ____ Respiratory Symptoms: ____
 Other, specify: _____

Was a stool/blood sample taken by a doctor at the time of the illness? Y N

If yes, was a specific illness/pathogen identified? _____

Physician Contact Name: _____ Physician Phone #: _____

Background Information (Circle Yes or No)

Contact with someone with a similar illness? Y N DK

Names & Details: _____

Attended Large Gatherings or group meals? Y N DK

Location & Details: _____

Travel outside community? Location _____ Y N DK

Date Departed Home ____/____/____ Date Returned home ____/____/____

Drinking Water Source: Public Water ____ Well Water ____ Bottled Water ____

Eat out/ take out at restaurant in last 72 hours? Y N DK

Location & Details: _____

Recreational swimming in last 72 hours? Y N DK

Location & Details: _____

STATE USE ONLY: Complaint # ____ Date received first report: ____/____/____ Date Sent to State ____/____/____
 Associated with Outbreak? Y N DK Outbreak # ____ Completed by _____ Tel# _____