

Stormwater Management in Pacific and Caribbean Islands: A Practitioner's Guide to Implementing LID

February 2014



Prepared for:
NOAA Coral Reef Conservation Program

Prepared by:
Horsley Witten Group, Inc. and
Center for Watershed Protection, Inc.



Acknowledgements

This Guide is funded by the NOAA Coral Reef Conservation Program as part of the agency's efforts to help protect coral reef ecosystems from land based sources of pollution. A number of individuals have been integral in providing insights into how stormwater is managed throughout the Pacific and Caribbean islands. Mahalo to Dr. Kathy Chaston, Hudson Slay, and Todd Cullison (Hawaii); Brian Bearden, Fran Castro, Dana Okano (CNMI); Brian Rippy, Kuka Matavao, and Christianera Tuitele (American Samoa); Vangie Luan and Esther Taitague (Guam); JP Oriol, Alexis Doward, Ben Kuelarts, Anita Nibbs, Julie Wright, and Sharon Coldren (USVI); Paul Sturm (Puerto Rico); and other tropical stormwater aficionados. Si' Yu'us Ma'ase for sharing your stories, photos, and lessons learned. Keep up the good work. Manuia!

Use of this Guide

This guide is intended for designers, engineers, agencies, and others in the Pacific and Caribbean islands who are familiar with stormwater concepts and interested in alternatives to ponding basins and detention ponds for managing stormwater. This guide is for those of you seeking to apply a Low Impact Development (LID) approach to improve water quality treatment, rainwater reuse, and recharge to better protect paradise. We assume you already understand watershed hydrology, the impacts of impervious cover on receiving waters, and the basic best management practices (BMPs) used for stormwater management state-side. This guide is intended to inspire you to advance the application of LID practices in Hawaii, CNMI, Guam, American Samoa, USVI, and Puerto Rico by showing you that it has been done before, and by outlining the steps you can take to be successful.

To this end, this guide is unique in that it is written for island stormwater practitioners. It relies on photos, design details, and specifications for BMPs used in the islands to protect coral reefs, maintain drinking water aquifers, and collect precious rainwater resources. As such, this guide does not prescribe regulatory standards, nor does it simply reiterate design information found in other manuals. This guide can and should be used to help you:

- Articulate different design objectives (e.g., water quality treatment, recharge, reuse, and flood control) and inform the sizing and selection of appropriate BMPs where local guidance is lacking;
- Recognize opportunities to promote LID in three key parts of a project site: vegetated areas, paved areas and rooftops, and within existing storage BMPs;
- Provide guidance on design, construction, and installation techniques to improve effectiveness based on lessons learned from island examples;
- Supplement state and territorial stormwater standards (where they exist), inform standards development (where they currently do not), and provide a design framework for stormwater projects; and
- Access updated precipitation frequencies and design storm depths.

Table of Contents

Chapter 1. Island Stormwater Management	1-1
What is LID?	1-2
Factors Influencing Green Infrastructure/LID.....	1-6
Are We Required to Use LID?	1-8
Overcoming Challenges to LID.....	1-9
Organization of this Guide	1-9
Chapter 2. Methods for Stormwater BMP Design	2-1
Step 1. Identifying Treatment Objectives and Pollutants of Concern	2-2
Step 2. Develop Performance Standards Based on Treatment Objectives	2-2
Step 3. Select Candidate BMPs	2-5
Step 4. Determining Sizing and Volume for BMPs.....	2-8
Step 5. Allocate Storage to Various Components of Your BMP Design.....	2-13
Step 6. Address other BMP Design Elements	2-14
Chapter 3. Using Vegetated Areas for Stormwater “Greening”	3-1
Seizing the Opportunity	3-2
Island Vegetated BMP Options	3-5
Island Bioretention.....	3-8
Bioretention Sizing.....	3-14
Unique Island Factors	3-15
Key Design Considerations.....	3-15
Island Bioretention Construction Sequence	3-23
Avoiding Common Pitfalls.....	3-24
Island Case Studies.....	3-26
Chapter 4. Rethinking Parking Lots and other Hardscapes	4-1
Seizing the Opportunity	4-2
A Word on Rainwater Harvesting and Using Rooftops.....	4-5
Using Permeable Surfaces	4-7
Sizing Permeable Paving Systems	4-15
Unique Island Factors	4-16
Key Design Considerations.....	4-16
Permeable Pavement Construction Sequence	4-20
Avoiding Common Pitfalls.....	4-22
Island Case Studies.....	4-24

Chapter 5. Improving Treatment at Existing BMPs5-1
Seizing the Opportunity 5-2
Retrofitting Existing Ponds..... 5-6
Sizing Multi-Cell Ponding Basins & Stormwater Wetlands 5-17
Unique Island Factors 5-18
Key Design Considerations..... 5-19
Construction Sequence 5-24
Avoiding Common Pitfalls..... 5-27

References

Appendix A: Precipitation Data Reference Guide

Appendix B: Island Plant Lists

Appendix C: Compost and Soils Specifications

Appendix D: Permeability Test Procedures

*The coconut stops here.
There is no reason that LID
can't be the preferred
approach to island
stormwater management.*

Chapter 1

Island Stormwater Management

The fundamental concepts of stormwater management on tropical islands are not entirely different from other regions. Water still flows downhill, flood control is still an engineering priority, impervious cover and compacted soils still generate surface runoff, and the first flush is still contaminated. Recharge remains an important strategy for sustaining groundwater supplies in the long-term, and removing pollutants prior to discharge is critical to protecting the quality of receiving waters. Island watersheds respond negatively when the natural hydrology is altered by human activities.

It is true, however, that precipitation frequencies and intensities in the tropics differ from more temperate regions; best management practice (BMP) selection and design will require special attention depending on limestone or volcanic-dominated geologies; and some construction materials may have to travel first by boat. Economically important coral reefs, sole source drinking water aquifers, and rare mangroves or salt ponds are often the downstream receiving waters. Drainage infrastructure, where it exists, is often designed and constructed based on available space and materials rather than a preferred set of design standards. In fact, there may not be any local stormwater standards to guide engineers on how to size and design BMPs. Lack of design standards may lead to the infiltration of contaminated stormwater into groundwater supplies, the undersizing of practices, or increased



*At He'eia State Park on
Oahu, a newly installed
rain garden absorbs
rooftop runoff using plants
and amended soils
(photo: Hui o Ko'olaupoko)*

maintenance burdens. That being said, islands are relatively small places where inhabitants are intimately tied to their land and water resources. Circumstances alone should prompt islanders to manage stormwater runoff:

- Traditional community boundaries often centered on natural drainages (e.g., Hawaiian ahupua'a and Samoan village structure), so residents are aware of how land use changes can affect watershed hydrology.
- Local economies rely on clear waters, healthy reefs, and robust fisheries; thus, BMPs designed to eliminate sediment plumes offer immediate, visible results to resource users.
- In some locations, rainfall is the primary source of freshwater, so using BMPs like cisterns or storage chambers to collect runoff for potable and non-potable reuse makes water supply sense.
- Tropical vegetation is fast-growing and plays a huge part in the water cycle, so stormwater management approaches that take advantage of canopy interception and evapotranspiration to reduce runoff have a high chance of success.
- Island infrastructure is subject to big storms, rising seas, and tsunamis; therefore redundancy within the stormwater system improves resiliency.

With this in mind, this guide challenges you to re-envision how island landscapes are developed and how stormwater is managed. Specifically, this guide promotes a low impact development (LID) approach to managing stormwater runoff that minimizes the impact of impervious cover on aquatic systems and employs techniques to better mimic natural hydrology.

What is LID?

Low impact development is an approach to land development that:

- 1) **Avoids** disturbance of existing vegetation, valuable soils, and wetlands to the maximum extent possible (e.g., minimizing site disturbance and maintaining vegetated buffers along waterways);
- 2) **Reduces** the amount of impervious cover and, thus, stormwater runoff generated on a site through careful site planning and design techniques; and
- 3) **Manages** runoff that is generated through structural and non-structural practices that filter, recharge, reuse, or otherwise reduce runoff from the site.

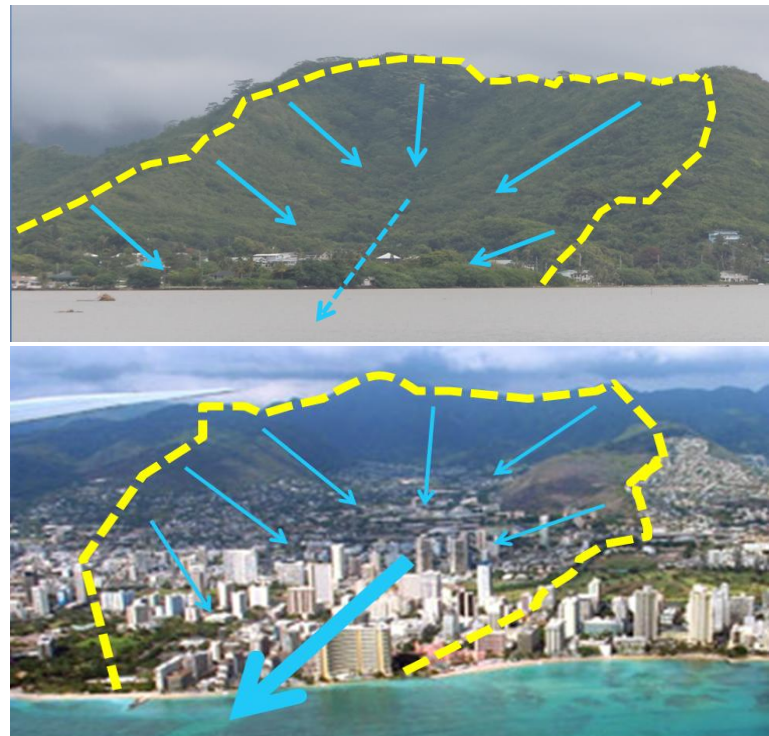

The hydrology of undeveloped (top) and urbanized (bottom) watersheds is significantly different. Urban watersheds experience increased flooding frequencies, more water quality problems, reduced groundwater recharge, and declining biological health. This trend corresponds directly with increased surface runoff generated by impervious cover and the loss of vegetation and native soils.



LID includes site design techniques to minimize the amount of impervious cover used on a site, like this parking lot in Honolulu that uses narrow drive aisles and small parking stalls.

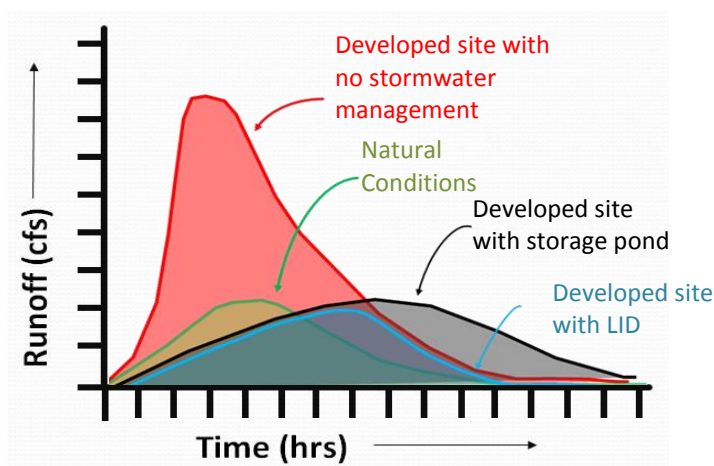

This representative hydrograph illustrates why stormwater management objectives have evolved over time. Comparing the runoff hydrograph between a natural, undeveloped site (green) and a developed site (red) shows a significant increase in the amount of runoff (area under the curve) and the speed at which the peak flows occur during a rain event. The use of detention basins (black curve) helps reduce the peak flow, but extends the length of time that large volumes of stormwater are released, causing downstream erosion. An LID approach (blue) that reduces total runoff volumes and peak flows better mimics the natural condition.

Then

The LID approach is, perhaps, best appreciated within the context of how stormwater management has evolved over the past decades.

Pipe and Pond Approach—in previous decades, stormwater management meant getting rainwater off the site as quickly as possible using pipes to convey runoff directly to receiving waters. This direct discharge approach increased the speed and volume of stormwater surface discharge, which caused flooding. In response, large storage basins/ponds were constructed to temporarily detain runoff and slow discharge. Unfortunately, these storage basins offered little in the way of water quality treatment and often created downstream erosion.

Multi-purpose BMPs—water quality issues and problems with peak flow-centric management led to a new set of objectives for managing small storms. Separate storage volumes were allocated in BMP designs to meet recharge, water quality, and channel protection criteria in addition to flood control. New filtering and infiltration BMPs were introduced and storage basin designs were revamped with extended detention, sediment forebays, and vegetation to improve pollutant removal and recharge.

Reducing Runoff with LID—despite improvements in the quality and control of stormwater discharges, we learned that better replication of a site's natural hydrology is needed to maintain watershed health. To this end, the reduction of runoff leaving the site has become the new focus. Under the modern stormwater paradigm of LID, the goal is to manage a large fraction of the stormwater generated on-site by reducing or disconnecting impervious cover, using vegetation to absorb runoff, and diverting remaining surface flows into smaller practices for filtering, recharge, and reuse.

The Evolution of Stormwater Management

Now



Direct Discharge

Pipes and concrete swales discharge stormwater directly from parking lots (left) and roads (right) in American Samoa. This is how runoff was managed before issues of water quality were fully appreciated.

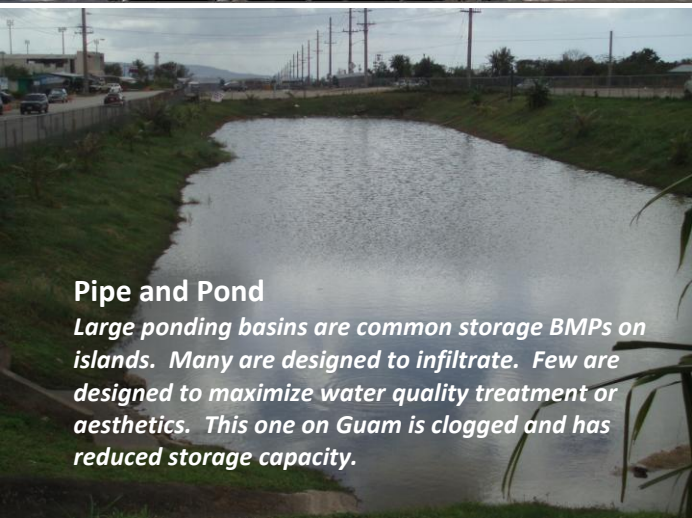

Pipe and Pond

Large ponding basins are common storage BMPs on islands. Many are designed to infiltrate. Few are designed to maximize water quality treatment or aesthetics. This one on Guam is clogged and has reduced storage capacity.



Multi-Purpose BMPs

This basin at University of Guam does more than provide storage, it has a concrete sediment forebay to prevent clogging and a grass filter to help remove pollutants prior to infiltration.



Reducing Runoff with LID

Smaller, distributed BMPs such as rain gardens, linear bioretention, cisterns, green roofs, and permeable parking shown here help reduce the total volume of runoff leaving (or generated) on site.



The primary focus of this guidebook is on the structural practices used to manage runoff—also commonly referred to as **green infrastructure** (the third tenet of LID noted earlier in this chapter). These practices include BMPs such as infiltration basins, bioretention, rain gardens, vegetated swales, permeable pavers, green roofs, and cisterns. Applying green infrastructure/LID practices means:

- Distributing smaller BMPs around the site (e.g. integrate into landscaping, parking area, and rooftops) to manage portions of site impervious cover (see Chapters 3-4);
- Relying on smaller BMPs than traditional storage practices since they are designed to manage smaller drainage areas; and

- First using volume reducing practices to promote infiltration, reuse, or evapo-transpiration, then using vegetation and/or engineered media to filter runoff where off-site release or discharge is inevitable (**Figure 1-1**).

While stormwater management on many Pacific and Caribbean islands is not well-advanced, there are a few intriguing examples of innovative stormwater designs that are demonstrations of things to come. **Figure 1-2**, for example, illustrates a variety of green infrastructure practices used at the renovated American Samoa Environmental Protection Agency building in Pago Pago, one of the first LEED-certified buildings in the South Pacific.

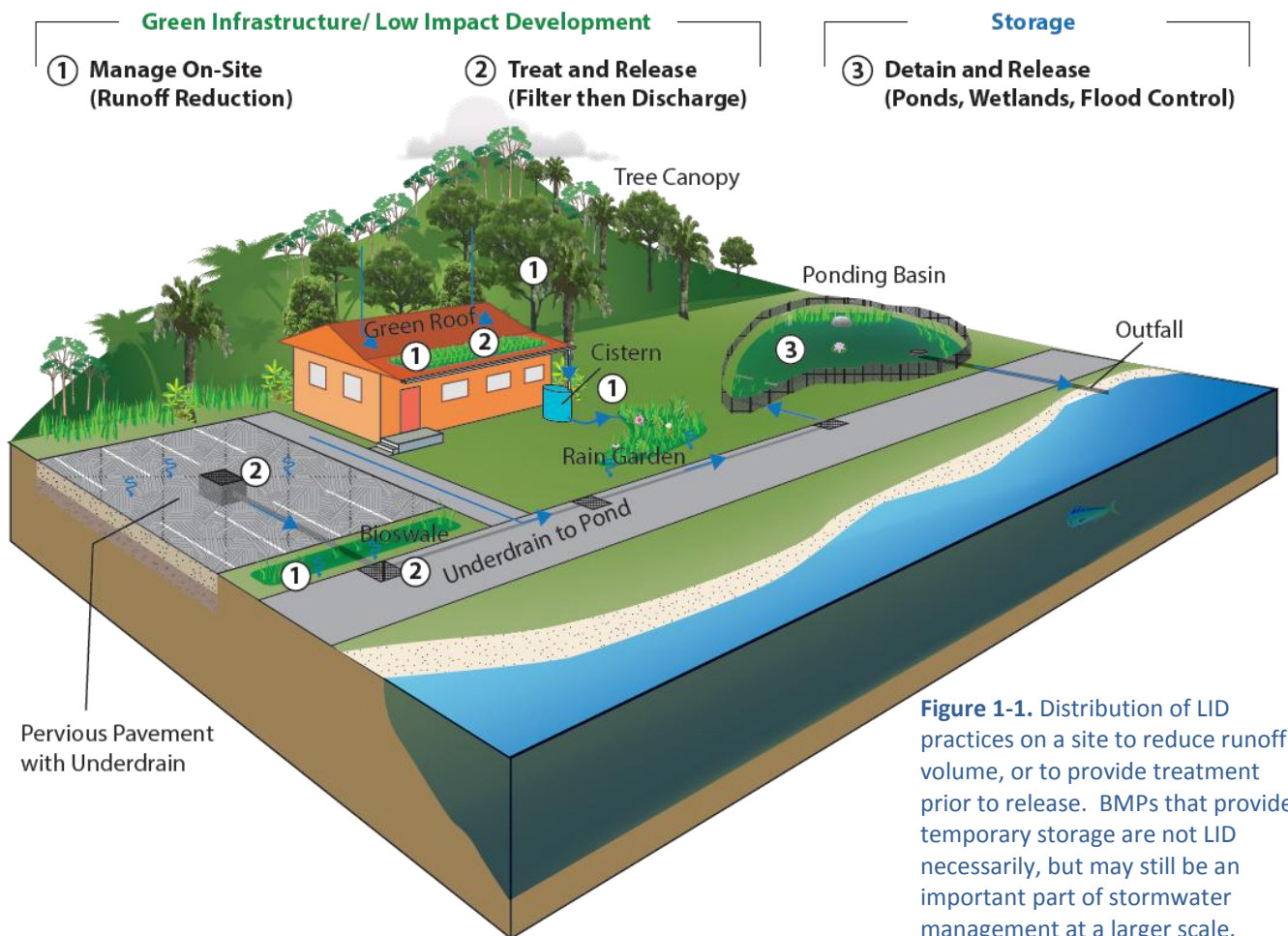

Figure 1-1. Distribution of LID practices on a site to reduce runoff volume, or to provide treatment prior to release. BMPs that provide temporary storage are not LID necessarily, but may still be an important part of stormwater management at a larger scale.

Throughout this guide, examples are provided of green infrastructure practices from island jurisdictions.

Factors influencing green infrastructure/LID practices

When selecting and sizing green infrastructure, consider:

- **Rainfall.** LID focuses on the small, frequent storms rather than the 100-yr events that dominate flood control discussions. Rainfall depths for the 1-yr storm or frequent “water quality storm” (e.g., 90th percentile event) are commonly referenced on the mainland, but may not be readily available in many of the islands, making efficient practice sizing difficult. Plus, there can be significant variations in annual precipitation across an island due to elevation changes and predominant wind direction. **Appendix A** provides a summary of precipitation data available for the islands.
- **Soils.** The native soils at a site will have a big influence on how runoff is generated and managed. Areas where limestone and sand exist may be suitable for infiltration BMPs; however, care must be taken to provide for water quality treatment prior to discharge into groundwater supplies. Volcanic soils and the impermeable “caliche” found in the USVI are less suitable for infiltration practices and may require an emphasis on treatment and release, detention, or reuse to satisfy LID objectives.
- **Slope.** It can be challenging to build on and manage stormwater on steep slopes. Permeable pavements, for example, become problematic once

slopes exceed 3-5%. Fortunately, islanders tend to be creative and know how to adapt to unique conditions. Minimizing cut slopes, protecting soils, and maintaining vegetative cover will be priorities for LID site design. Capture and reuse, impervious disconnection, terraced BMPs, and stable conveyances should drive stormwater plans.

- **Land use.** Pollutant loads and concentrations will vary depending on land uses and attendant activities. Runoff from a gas station, for example, is the last thing you want to direct to an infiltration practice sitting on top of your drinking water aquifer. Liners, pretreatment, or other techniques should be employed as needed. In addition, BMP design will be influenced by the varying maintenance and landscaping requirements for residential, school, retail, institutional, or industrial properties.
- **Critical Areas.** Guam, CNMI, and Palau require different treatment volumes based on a site’s proximity to sensitive waters or drinking water supplies. Some BMPs are better than others when it comes to removing specific pollutants of concern. If receiving waters are impaired for bacteria, for example, infiltration practices should be preferred.

The recommended calculation procedures and practice design specifications in **Chapters 2** through **5** will account for each of the factors discussed above.

Figure 1-2. The American Samoa EPA Office building uses parking lots, rooftops, and vegetated areas to managed stormwater (photos: Brian Rippy and ASEPA).

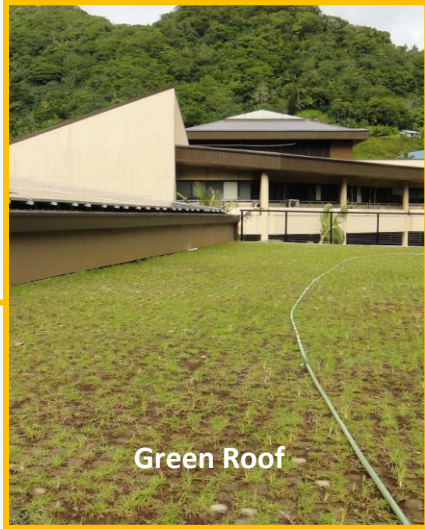

Green Roof

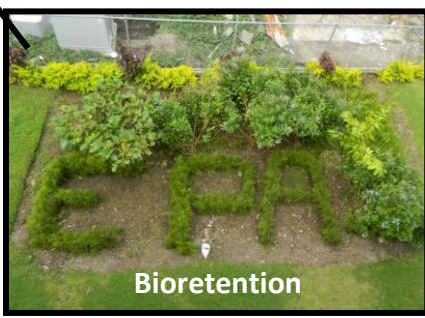

Bioretention



Permeable Interlocking Concrete Pavers



Bioretention

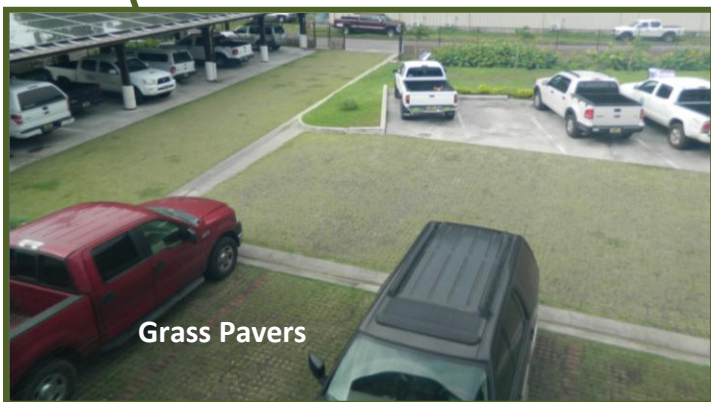

Grass Pavers

Are we required to use LID?

As Federal Clean Water Act provisions, green building standards, and sustainable community goals have become more interconnected, LID has grown more popular in the U.S. and other countries. Maryland, Virginia, North Carolina, Rhode Island, and other states now require or provide strong incentives for the LID approach to stormwater management by restricting approved practices, establishing more stringent pollutant removal standards, or establishing volume reduction performance criterion. Montgomery County, Maryland and New York City have set impervious cover disconnection targets that apply to new development, redevelopment, and retrofit activities. Perhaps one of the islands will be next in line to adopt stringent LID requirements.

While recommended in many cases, LID is **not** currently mandated by any of the Pacific and Caribbean jurisdictions. The US Department of Defense, however, has on-site retention standards for new federal facilities that provide a strong incentive for LID designs, which could be significant in Guam, Hawaii, and other locations where the military has active development projects. Also, the USVI mandates cisterns for the capture and reuse of rooftop runoff for residences and businesses; although sizing and drawdown of these systems is based on estimated occupancy rather than design storms and runoff reduction criteria.

Stormwater requirements in the islands generally fall under island-specific rules and regulations, the federal National Pollution Discharge Elimination Program (NPDES), or other federal requirements for highways or military installations. **Table 1-1** lists the

primary agencies responsible for stormwater program administration.

Table 1-1. Island Stormwater Agencies

Island	Stormwater Agency
Hawaii	<ul style="list-style-type: none"> NPDES--Hawaii Department of Health, Clean Water Branch http://health.hawaii.gov/cwb/ City and County of Honolulu www.cleanwaterhonolulu.com/storm/
Guam	<ul style="list-style-type: none"> NPDES--US EPA Region 9 www.epa.gov/region9/water Guam Environmental Protection Agency http://epa.guam.gov/ Guam Department of Public Works http://www.dpw.guam.gov/
CNMI	<ul style="list-style-type: none"> NPDES--US EPA Region 9 www.epa.gov/region9/water Division of Environmental Quality www.deq.gov.mp
American Samoa	<ul style="list-style-type: none"> NPDES--US EPA Region 9 www.epa.gov/region9/water AS Enviro. Protection Agency http://asepa.gov/default.asp
Republic of Palau	Environmental Quality Protection Board
USVI	TPDES/Earth Change—Dept. of Planning and Natural Resources www.dpnr.gov.vi/
Puerto Rico	<ul style="list-style-type: none"> NPDES—US EPA Region 2 Department of Natural and Environmental Resources www.drna.gobierno.pr/

Table 1-2 summarizes key stormwater reference documents to consult for applicable standards and requirements. CNMI, Guam, and Palau have stormwater design manuals that outline required standards and design specifications for post-construction stormwater management. Hawaii also has guidance manuals—the County and City of Honolulu having most recently published new design standards. Puerto Rico and the USVI do not currently have regulatory criteria for post-construction stormwater management, although efforts are currently underway to develop and adopt regulatory standards in the USVI.

Overcoming Challenges to LID

Fully embracing LID as the preferred approach to stormwater management in the islands will require capitalizing on aspects of island culture that lend themselves to LID, overcoming physical and regulatory challenges unique to island settings, and avoiding common LID mistakes. Island communities will want to take advantage of the following to generate support for LID projects:

- Paving is expensive and native soil is valuable, so minimizing site disturbance and the use of impervious cover has an economic benefit.
- Freshwater is precious, therefore rain water harvesting and reuse makes a lot of sense.
- BMP performance and the climate are unpredictable, so it makes sense to distribute smaller BMPs rather than relying on one big pond.
- Space is a premium, and ponding basins use lots of valuable real estate.
- Evapotranspiration rates are high and vegetation growth rates are fast, making plants a significant component for stormwater BMPs.

Table 1-3 provides some suggested responses to common misconceptions and arguments against using LID.

Organization of this Guide

The remainder of this guide is intended to help designers, reviewers, and other practitioners envision how LID practices can be integrated into the vegetated, paved, and rooftop areas of a project site, as well as how to improve the performance of existing BMPs. It is organized as follows:

Chapter 2. Methods for Stormwater BMP Design—This six-step method for selecting and sizing BMPs is not intended to supersede any existing methods required locally, rather, it gives guidance where existing instructions are lacking, calculation methods are flexible, or where an alternative sizing approach is helpful.

Chapter 3. Using Vegetated Areas for Stormwater “Greening”—Don’t just default to turf grass! Vegetated spaces are perfect for stormwater management. This chapter gives examples of how islanders are integrating landscaping with LID and provides island-derived design specifications for vegetated BMPs that you may not have seen before.

Chapter 4. Rethinking Parking Lots and Other Hardscapes—Not all pavement has to shed water—“go permeable” is the new stormwater mantra! This chapter offers examples of various BMPs that can be used on rooftops, parking lots, patios, and other hardscapes, with a focus on design specifications for permeable pavers. If you can’t apply these techniques, at least consider other ways to LID your hardscapes.

Chapter 5. Improving Treatment at Existing BMPs—A cost-effective way of improving watershed conditions is to improve performance of existing BMPs. This chapter suggests techniques for modifying conventional ponding basins.

Appendix A. Precipitation Data Reference Guide—NOAA and other available rainfall data for specific islands intended to supplement local rainfall information, but not to necessarily supersede required treatment depths/volumes derived from more rigorous analysis.

Appendix B: Island Plant Lists—References to existing local plant lists and lessons-learned from vegetated BMP installations.

Appendix C: Compost and Soil Specs—Suggestions for making your own island media.

Appendix D: Permeability Test Procedures—A low-tech approach to determining soil drainage potential.

Table 1-2. Island Stormwater Design Manuals

Island	Stormwater Resources
Hawaii	<ul style="list-style-type: none"> • 2013 Hawai'i Residential Rain Garden Manual, Hui o Ko'olaupoko • 2012 City and County of Honolulu Stormwater BMP Guide (Final) • 2012 Green Infrastructure for Homeowners, City and County of Honolulu • 2008 Reclamation & Reuse BMP Handbook, Commission on Water Resource Management • 2008 Construction BMPs Field Manual, Hawaii Dept. of Transp. • 2006 Design Guidelines for Stormwater Treatment Practices To Protect Water Quality in Maui County, Hawaii, Center for Watershed Protection
Guam	<ul style="list-style-type: none"> • 2012 Guam Erosion and Sediment Control Field Guide, Guam Bureau of Statistics and GEPA • 2010 Guam Transportation Stormwater Drainage Manual, Department of Public Works • 2010 Island Stormwater Practice Design Specifications Supplement • 2006 CNMI and Guam Stormwater Management Manual, Guam EPA
CNMI	<ul style="list-style-type: none"> • 2009 CNMI Erosion and Sediment Control Field Guide, DEQ • 2006 CNMI and Guam Stormwater Management Manual, CNMI Division of Environmental Quality
American Samoa	<ul style="list-style-type: none"> • 2011 American Samoa Erosion and Sediment Control Field Guide, AS-EPA • 2001 Guidance Manual for Runoff Control, AS-EPA
Republic of Palau	<ul style="list-style-type: none"> • 2010 Palau Stormwater Management Manual, EQPB • 2010 Palau Erosion and Sediment Control Field Guide, EQPB
USVI	2002 USVI Environmental Protection Handbook, University of the Virgin Islands Cooperative Extension
Puerto Rico	2005 Puerto Rico Erosion and Sediment Control Handbook for Developing Areas, PR Environmental Quality Board and USDA-NRCS

Table 1-3. Common Arguments against LID

Arguments	Possible Responses
LID costs more than traditional stormwater detention basins.	Somewhat true. LID practices can have higher construction costs on a per impervious acre treated basis when compared to a large detention pond. But when savings associated with reduced pavement, pipes, land value, and downstream restoration projects are accounted for, LID will generally cost less (see US EPA's latest publication on LID cost benefits http://water.epa.gov/infrastructure/greeninfrastructure/gi_costbenefits.cfm). Additional permitting efforts may be required for LID, unless local policies favor LID.
LID has never been done in the islands.	Not true. Several examples are shown in this document. Besides, there is a market benefit for a design professional or contractor to become proficient at designing and installing LID practices.
You can't get the materials on the island.	Not completely relevant. LID practices can be designed using local materials and native vegetation. Plus, there are many different BMPs that can be used based on site conditions and materials available.
My client won't do it unless it is required.	May be true, but: Part of the consultant's job is to educate and encourage clients to do the right thing. LID is being required in many states, and it is only a matter of time before required in the islands. LEED certification, energy conservation, and other green construction approaches may provide incentives for reluctant site owners.
LID practices require too much maintenance and fail too frequently.	Not true. All BMPs require maintenance. There are design and construction techniques to help reduce maintenance burden and help prevent failure.
	Not true. All BMPs require maintenance. Don't ignore off-site drainage contributions and pretreatment needs during design stages. Design for ease of long-term maintenance, and avoid over-reliance on proprietary devices requiring "specialized" equipment. Don't underestimate the importance of non-structural BMPs. Don't allow sediment to clog the practice during construction. Avoid compacting soils below infiltration BMPs and check any engineered soil media before installation. Do not over-plant. Be sure to specify standards for island equivalents if using mainland specs.

*The selection and design of stormwater BMPs should be reflective of the management objectives and pollutants of concern in the respective watershed.
(photo: Palau International Coral Reef Center)*

Chapter 2.0

Methods for Stormwater BMP Design

This chapter contains a “typical” stormwater best management practice (BMP) design method, beginning with identifying big-picture management objectives and ending with a detailed BMP design. This can be considered a generic method that can be adapted to the needs of each island jurisdiction.

Obviously, several jurisdictions already have stormwater regulations and/or associated design manuals, so it is not the intent of this chapter to supplant those existing resources. Rather, the method is a structured, step-by-step process so that all stakeholders involved in stormwater BMP planning and design can find common ground as they move from idea to implementation. It is not anticipated that ALL stormwater projects will use ALL six steps outlined below, as the method can be tailored to local needs. The six steps include:

1. Identify Management Objectives
2. Develop Performance Standards Based on Management Objectives
3. Select Candidate Structural & Non-Structural BMPs
4. Determine Sizing & Volume for BMPs
5. Allocate Storage to Various Components of Your BMP Design
6. Address Other BMP Design Elements



LID, small storm hydrology, and climate change have made rainfall data analysis a glamorous venture.

Step 1. Identify Management Objectives & Pollutants of Concern

Management objectives represent the overall or “big picture” goal for undertaking a stormwater design. Some management objectives are defined by regulations and associated stormwater manuals, while others may be driven by watershed restoration plans or related infrastructure projects.

Another aspect of articulating management objectives is identifying any pollutants of concern related to the objective. Pollutants of concern can influence the types of stormwater BMPs selected, as well as their sizing, materials used, and other design features.

As such, the management objectives can be expressed as volumes of runoff (i.e., volumes that should be infiltrated, reduced, or reused at a site). The idea is that reducing these volumes and replicating a more natural hydrology will also, by default, reduce pollutant loads (since there is less water to carry pollutant downstream) and provide wider benefits in terms of healthy waterways and ecosystems.

Table 2-1 outlines several common management objectives and associated pollutants of concern and/or runoff volume reduction objectives.

Step 2. Develop Performance Standards Based on Management Objectives

After management objectives and pollutants of concern and/or runoff volume goals are identified, the next step is to

define very specific performance standards for your BMP design. Performance standards differ from more generalized management objectives in that they state specific design rules for a BMP and can help the designer address the following questions:

- How many BMPs are needed for a particular drainage area or site?
- How much storage volume should the BMPs have?
- What pollutant removal and/or pollution prevention mechanisms should the BMP have in order to address pollutants of concern?
- What materials should be used to build the BMP?

Put another way, performance standards give the designer a “recipe” for the BMP so that it can successfully meet the management objectives.

Table 2-2 provides examples of translating management objectives (from Step 1) to more specific criteria and performance standards. Please note that the performance standards in the table are examples, and can be modified based on local conditions or regulations.

Table 2-1. Stormwater Management Objectives & Pollutants of Concern





Management Objective	Pollutants of Concern/Runoff Volume	Examples
<p>Comply with Stormwater Regulations & Manuals for Applicable New Development & Redevelopment Projects</p>	<p>Regulations and manuals may include the following pollutants of concern and/or flood control objectives:</p> <ul style="list-style-type: none"> • Sediment: Total Suspended Solids (TSS) • Nutrients: Phosphorus & Nitrogen • Peak flows & volumes <p>Some regulations may include a “keystone” or “target” pollutant that drives BMP selection and design, but it is assumed that other pollutants are also reduced along with the target. The most common pollutant standard is 80% TSS removal.</p>	
<p>Comply With Federal Facilities Guidelines & Rules (e.g., EISA 438)</p>	<p>EISA 438 is one of the standards that uses the LID principle of maintaining “predevelopment hydrology,” and thus focusing on the volume of runoff. The standards specifically mention the “temperature, rate, volume, and duration” of stormwater runoff (see Box 2-1).</p>	
<p>Reduce pollutants of concern and/or runoff volumes in accordance with TMDLs or watershed restoration plans</p>	<p>TMDLs and restoration plans can have various pollutants of concern. Common pollutants of concern for islands and coastal communities include:</p> <ul style="list-style-type: none"> • Bacteria, microbial contaminants • Nutrients • Sediment and solids • Industrial contaminants (e.g., metals, PCBs) 	
<p>Conduct a Demonstration Project as part of an Educational Program</p>	<p>Many jurisdictions start to build support for LID with one or several demonstration projects. It is important for these projects to reflect the management objectives for the island’s stormwater requirements, guidelines, recommendations, and/or pollutants of concern in TMDLs.</p>	
<p>Address Polluted Runoff From “Stormwater Hotspots”</p>	<p>Stormwater hotspots are sites/land uses that produce disproportionately high pollutant loads and/or have elevated risks for spills and leaks. Examples include vehicle maintenance shops, large parking lots, public works yards, resource extraction (e.g., quarries), and solid waste handling and disposal. Pollutants vary based on the type of operation, but may include: oil and grease, detergents, heavy metals, other chemicals: herbicides, pesticides, and solvents. Some hotspot operations are required to obtain a relevant discharge permit (NPDES) and thus have a stormwater pollution prevention plan (SWPPP).</p>	

Table 2-2. Examples of Management Objectives, Criteria, and Performance Standards

Management Objectives (see Table 2-1)	More Specific Management Criteria	Performance Standards (Examples)
Comply with Stormwater Regulations & Manuals for Applicable New Development & Redevelopment Projects	<ul style="list-style-type: none"> Promote groundwater recharge Protect water quality by capturing and treating runoff for pollutants of concern Protect downstream channels and properties from erosion and nuisance flooding 	<ul style="list-style-type: none"> <u>Groundwater</u>: Maintain pre-development annual groundwater recharge rates <u>Water Quality</u>: Treat runoff for storm events up to and including the 90th percentile storm event; achieve 80% reduction of TSS <u>Channel Protection</u>: Provide extended detention for the 1-year, 24-hour storm <u>Flood Protection</u>: Maintain pre-development peak runoff rates for the 10 and 25-year storm events
Comply With Federal Facilities Guidelines & Rules (e.g., EISA 438)	Maintain or restore, to the maximum extent technically feasible (METF), the predevelopment hydrology of the property with regard to the temperature, rate, volume, and duration of flow.	Manage on-site the total volume of rainfall from the 95 th percentile storm.
Reduce pollutants of concern and/or runoff volumes in accordance with TMDLs or watershed restoration plans (through stormwater retrofit projects)	<ul style="list-style-type: none"> Capture and treat runoff for pollutants of concern Help fix downstream erosion and/or drainage in conjunction with stream channel projects 	<ul style="list-style-type: none"> Treat at least 0.5" of runoff from impervious surfaces in the drainage area Provide 24-hour extended detention for the range of storm events that cause downstream channel problems
Conduct a Demonstration Project as part of an Educational Program	<ul style="list-style-type: none"> Demonstrate an innovative practice to promote broader implementation Provide educational signage and events 	<ul style="list-style-type: none"> Build selected practice(s) at a site with wide public exposure Size adequately to manage the drainage area based on available guides and manuals
Address Polluted Runoff From "Stormwater Hotspots"	Reduce pollutants of concern in runoff	<ul style="list-style-type: none"> Use non-structural BMPs and operational changes to reduce exposure of pollutants to rainfall Select structural BMPs that maximize treatment for pollutant(s) of concern

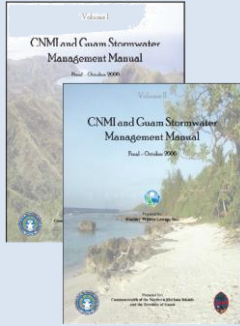
This Federal Act contains the following management objectives and criteria:

The sponsor of any development or redevelopment project involving a Federal facility with a footprint that exceeds 5,000 square feet shall use site planning, design, construction, and maintenance strategies for the property to maintain or restore, to the maximum extent technically feasible (METF), the predevelopment hydrology of the property with regard to the temperature, rate, volume, and duration of flow.

Federal guidance documents further establish the performance standards through two options:

1. *Manage on-site the total volume of rainfall from the 95th percentile storm; or*
2. *Determine pre-developed hydrology based on site-specific conditions and local meteorology by using continuous simulation modeling, published data, or other established tools to determine the water volume to be managed on-site.*

Links to EPA guidance and DOD UFC.

<http://water.epa.gov/polwaste/nps/section438.cfm>

http://www.everyspec.com/DoD/DoD-UFC/ufc_3_210_10_6606/

Step 3. Select Candidate Structural & Non-Structural BMPs

The next step is to use the management objectives, criteria, and performance standards to identify candidate BMPs that can best meet those goals. **Table 2-3** outlines the relationship between various performance standards and a short list of the “preferred” BMPs suited to meeting that standard. This is not meant to be an exhaustive list, as various BMP manuals contain more comprehensive lists of the types and capabilities of BMPs.

Of particular note, **Table 2-3** makes reference to practices such as better site design, disconnecting impervious cover, and using vegetated areas to manage stormwater. These site design and green infrastructure BMPs are very important and should be considered the first line of defense because they reduce runoff volumes and pollutant loads “by design.” They can prove to be the most cost-effective approach and also tend to have

the lowest requirements for long-term maintenance.

This manual assumes that site design practices will be used as a first step, followed by the structural BMPs described in more detail in **Chapters 3** through **5**. **Table 2-3** also has a column for “Feasibility Considerations.” While a particular BMP may have capabilities to meet performance standards, this does not mean that the BMP is suitable for use at every site. BMP specifications provide a list of site suitability conditions, which may include available space, soils, slopes, water table, aesthetics and safety, and other factors. Key feasibility considerations for the BMPs are listed, but the reader should consult the detailed specifications in **Chapters 3** through **5** (and other BMP manuals) for more detailed explanations.

Another way to evaluate various BMPs with regard to performance standards is to understand the pollutant removal processes that function within a BMP. BMPs may use

one or several of these processes to reduce pollutant concentrations and loads. **Table 2-4** provides an overview of some of the key pollutant removal processes for the most common BMPs.

Table 2-3. Examples of Performance Standards, “Preferred” BMPs, and Feasibility Considerations

Performance Standard	Short List of “Preferred” Island BMPs	Feasibility Considerations
<p>Groundwater Recharge: Maintain pre-development annual groundwater recharge rates</p> <p>AND/OR</p> <p>Runoff Reduction: Manage on-site the total volume of rainfall from the 90th or 95th percentile storm.</p>	<ul style="list-style-type: none"> • Bioretention, preferably without underdrain (Ch 3) • Infiltration (Ch 3 & 4) • Porous pavement (Ch 4) • Use natural vegetated areas and better site design to reduce impervious cover and accept sheetflow from upgradient developed areas (landscape infiltration) • Rainwater harvesting (runoff reduction) 	<ul style="list-style-type: none"> • Appropriate soils based on soil test • Water table is not too high • Bedrock is not too shallow • Runoff is not from stormwater hotspot or drainage area with high sediment loads
<p>Water Quality:</p> <ul style="list-style-type: none"> • Treat runoff for all storm events up to and including the 90th percentile storm event • Achieve 80% reduction of TSS 	<ul style="list-style-type: none"> • Non-structural practices & better site design: reduce & disconnect impervious cover, preserve vegetation. • Bioretention with or without underdrain (Ch 3) • Infiltration (Ch 3 & 4) • Porous Pavement with or without underdrain (Ch 4) • Stormwater Wetlands (Ch 5) • Sand & Other Media Filters 	<ul style="list-style-type: none"> • Appropriate soils for infiltration designs • Adequate hydraulic head for underdrains and outlets • Adequate footprint on the site • Aesthetics & safety
<p>Channel Protection: Provide extended detention for the 1-year, 24-hour storm</p>	<ul style="list-style-type: none"> • Stormwater wetlands (Ch 5) • Multi-cell ponding basin (Ch 5) • Appropriately-sized Bioretention (Ch 3) 	<ul style="list-style-type: none"> • Adequate footprint on the site • Water balance for stormwater wetlands
<p>Flood Protection: Maintain pre-development peak runoff rates for the 10 & 25-year storm events</p>	<ul style="list-style-type: none"> • Stormwater wetlands (Ch 5) • Multi-cell ponding basin (Ch 5) • Floodplain Management 	<p>Same as above</p>
<p>Stormwater Hotspots:</p> <ul style="list-style-type: none"> • Use non-structural BMPs and operational changes to reduce exposure of pollutants to rainfall • Select structural BMPs that maximize treatment for pollutant(s) of concern 	<ul style="list-style-type: none"> • Non-structural and operational measures that reduce or eliminate exposure of materials and chemicals to rainfall/runoff (as may be contained in a SWPPP) • Sand & Other Media Filters • Proprietary/Manufactured BMPs designed for pollutants of concern 	<ul style="list-style-type: none"> • Adequate hydraulic head for underdrains and outlets • Capacity for long-term maintenance needs (applies to all BMPs, but proprietary practices may have unique frequency or equipment requirements)

Table 2-4. Stormwater Pollutant Removal Processes & BMPs

Removal Process	Description and Pollutants Affected	BMPs
Gravitational Separation (also settling or sedimentation)	<p>Definition: Downward removal of solids denser than water, and floatation removal of those lighter than water.</p> <p>Pollutants: sediment, solids (particulates associated with other pollutants such as nutrients and metals), oil (hydrocarbons), BOD, particulate COD, and trash</p>	Rainwater Harvesting, Permeable Pavement, Grass Swale, BMPs with ponding component, Bioretention, Regenerative Stormwater Conveyance System, Filtration, Stormwater Wetlands, and Wet and Dry Extended Detention Ponds
Filtering	<p>Definition: Straining of pollutants by passing stormwater through a media finer than the target pollutants.</p> <p>Pollutants: solids, pathogens, particulate nutrients, particulate metals, BOD, particulate COD</p>	Filtration, Vegetated Filter Strips, Bioretention, Permeable Pavement, Grass Swale, Regenerative Stormwater Conveyance System, Vegetated Roof, Stormwater Wetlands.
Infiltration	<p>Definition: passing stormwater downward through existing soils below the surface grade</p> <p>Pollutants: volume, solids, pathogens, nutrients, metals, organics, BOD, particulate COD</p>	Infiltration, Vegetated Filter Strips, Bioretention, Permeable Pavement, Grass Swale, Regenerative Stormwater Conveyance System
Sorption	<p>Definition: Includes Adsorption and Absorption – the physical molecular level attraction of a pollutant to media or soil particles. No chemical change (such as ion exchange occurs).</p> <p>Pollutants: dissolved phosphorus, metals, and organics.</p>	Filtration, Vegetated Filter Strips, Bioretention, Permeable Pavement, Grass Swale, Regenerative Stormwater Conveyance System, Vegetated Roof, Stormwater Wetlands.
Biological Uptake	<p>Definition: Broadly termed transfer of substances from runoff to plants; can include evapotranspiration.</p> <p>Pollutants: volume, hydrocarbons, nutrients, metals, organics, BOD, particulate COD</p>	Vegetated Filter Strips, Bioretention, Grass Swale, Vegetated Roof, Stormwater Wetlands
Ion Exchange	<p>Definition: Molecular exchange of one ion from the soil or filter media with an ion in the stormwater to remove pollutants; the ion from the media passes harmlessly through with the stormwater, while the pollutant remains sequestered in the media.</p> <p>Pollutants: metals</p>	Filtration (depending on the media)
Chemical Transformation	<p>Definition: Process by which pollutants react with other compounds to change structure and are either harmlessly removed or sequestered.</p> <p>Pollutants: nitrogen (ammonia, nitrate, nitrite), organics, hydrocarbons</p>	Filtration, Vegetated Filter Strips, Bioretention, Permeable Pavement, Grass Swale, Regenerative Stormwater Conveyance System, Vegetated Roof, Stormwater Wetlands.

Step 4. Determine Sizing & Volume for BMPs

Now that you have identified management objective, performance goals, and candidate BMPs, you can begin the design process in earnest. Probably the most important design feature is the size and dimensions of your BMP. This will be a direct reflection of the storage volume you need to build into the BMP in order to meet the performance standard(s).

This step is data-driven, and can be broken down as follows:

- **BMP Drainage Area (DA):** The limits of the land area that will drain into the BMP. For development and redevelopment projects, this would be the “post-development” DA, since grades and topography may change during the development process.
- **Rainfall:** The depth of rainfall that corresponds to your performance standard(s).
- **Relating Rainfall to Runoff:** The soils and land cover conditions in the DA of your BMP will influence how much runoff is generated by a given rainfall event. This translates to the volume of runoff that needs to be managed.
- **Putting it all Together to Derive BMP Target Storage Volumes:** Using the above data to compute the target storage volume needed in any given BMP.

BMP Drainage Area

This is a straight-forward exercise of delineating the DA for your site or area of concern. For a given site, there may be one

or more DAs. As stated above, the “post-development” contours should be used for sites where grading will change the surface topography.

Rainfall

Your performance standards will dictate the type of rainfall data you will need. For instance, if you are primarily concerned about water quality treatment and/or runoff reduction, you will want to know the rainfall depth for the 90th or 95th percentile storm events. Ideally, you will have access to a good source of local data with an adequate period of record (something on the order of 30 years is desirable, but not essential; it is more important for the data to be from a reputable source somewhat close to your site or watershed). **Box 2-2** provides guidelines for deriving these rainfall depths by using a “Rainfall Frequency Spectrum” analysis. **Appendix A** includes rainfall data summaries from each jurisdiction.

It is important to note that the resulting rainfall depths represent an average annual depth that, when managed by a BMP, will reduce pollutant concentrations and loads in accordance with the performance standard. This is a simplification that does not account for rainfall intensity, back-to-back storm events, or other complexities associated with any given storm event. This is appropriate since pollutant loading is also most important when considered on a cumulative, annual basis, and BMP pollutant removal capabilities are expressed as averages from many storm events.

Alternately, if your performance standards also include channel and flood protection criteria (peak rate control), then you will need additional data on the recurrence

interval for the relevant storm events (e.g., 10-year, 24-hour storm). In contrast to the average annual data used for water quality performance standards, these data pertain to particular storm events. Rainfall data is analyzed for recurrence intervals and these data are used in hydrologic models, the most common being methods developed by the U.S. Department of Agriculture, Natural Resources Conservation Service (TR-55 and many derivative models). The rainfall/runoff relationship is established through Curve Numbers (CNs), and various types of storm hydrographs can be developed for pre-development and post-development conditions.

It is not the intention of this guide to reiterate these methods, as they are commonly used and readily available. Rather, **this guide will focus on water quality criteria that use the more frequent and smaller storm events.** The combination of runoff volume from smaller storms and pollutant concentrations translates into total pollutant loads that must be managed in order to meet the criteria.

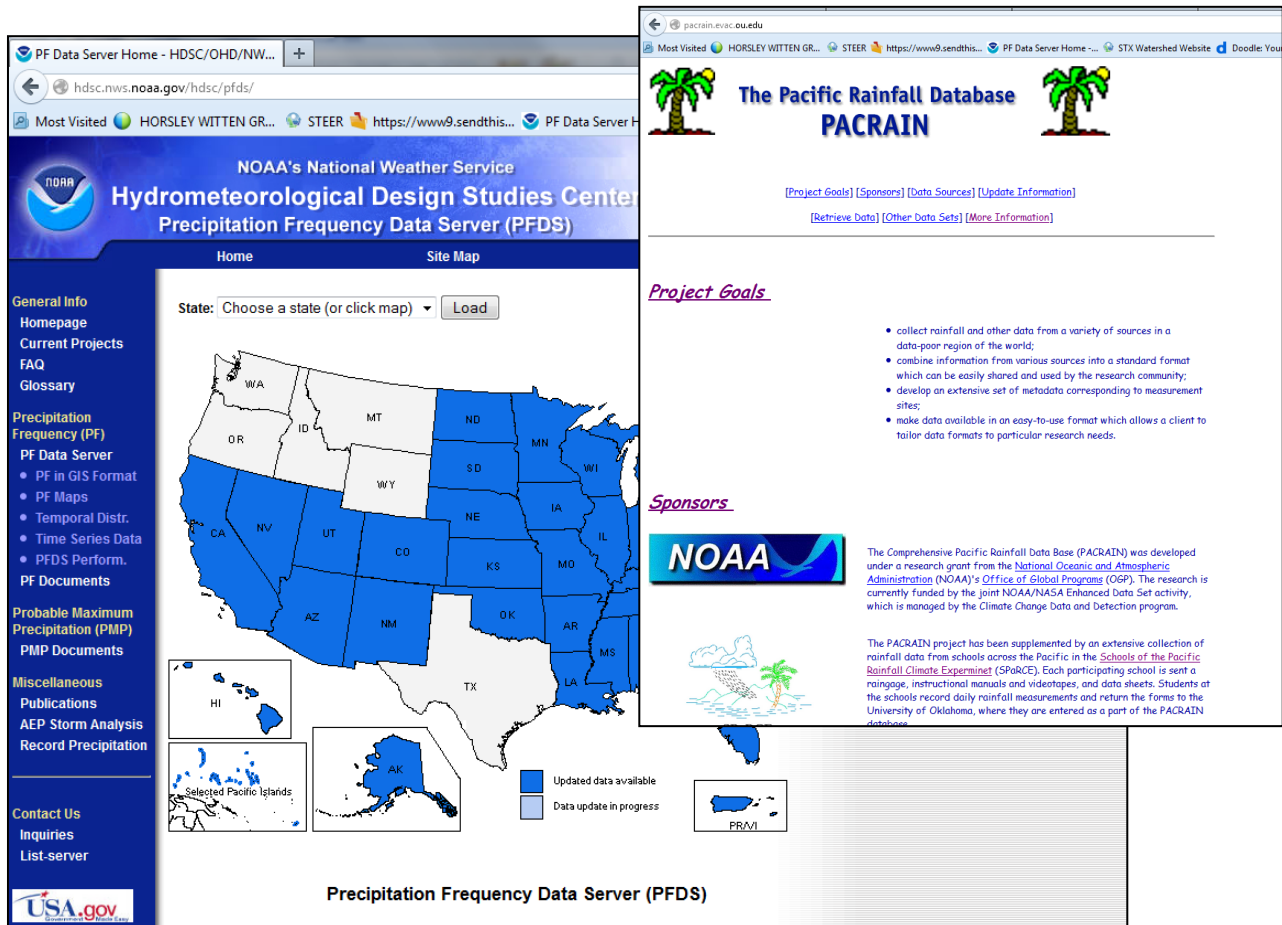

Two great sources for rainfall data include the NOAA's Precipitation Frequency Data Server (PFDS) and the Pacific Rainfall Database (PACRAIN) hosted by the University of Oklahoma.

Box. 2-2 Generating a Rainfall Frequency Spectrum

A Rainfall Frequency Spectrum (RFS) is a tool that stormwater managers should use to analyze and develop local stormwater management criteria and to provide the technical foundation for the criteria. Over the course of a year, many precipitation events occur within a community. Most events are quite small, but a few can create several inches of rainfall. An RFS illustrates this variation by describing how often, on average, various precipitation events occur during a normal year. The graph below provides an example of a typical RFS and shows the percentage of rainfall events that are equal to or less than an indicated rainfall depth. As shown, the majority of storm events are relatively small; 90% of all storms (90th percentile) is 1.6 inches or less. The 90% rainfall depth (or 95% for Federal Facilities EISA) is a recommended standard for the Water Quality Volume. In the Fagaitua example, the “knee of the curve” occurs around 2 inches, which may be an equally valid standard.

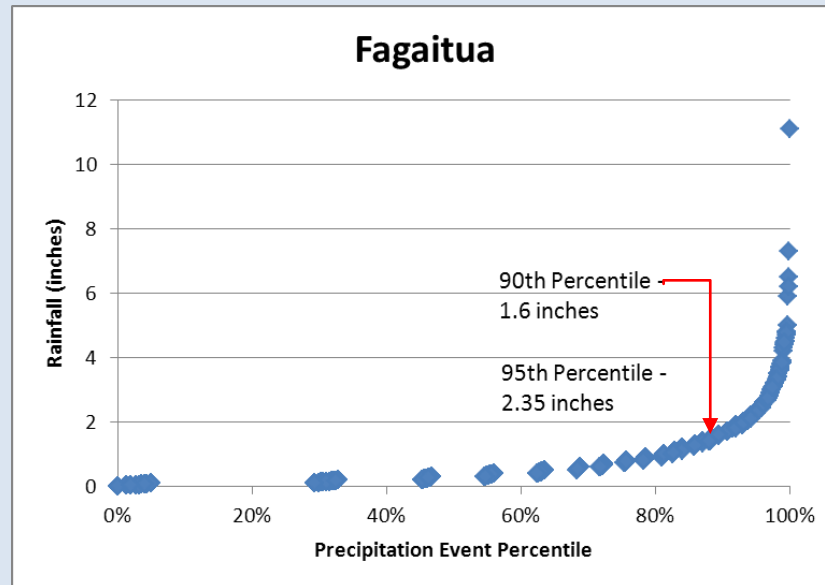

RFS for Fagaitua, American Samoa (1997–2008)

Guidance on creating an RFS is provided below. If a community is large in area or has considerable variation in elevation or aspect, the RFS analysis should be conducted at multiple stations.

1. Obtain a long-term rainfall record from an adjacent weather station (daily precipitation is fine, but try to obtain at least 30 years of daily record). There are several stations with relatively long-term rainfall records in the tropical region (see waterdata.usgs.gov/nwis). Local airports, universities, water treatment plants, or other facilities might also maintain rainfall records.
2. Edit out small rainfall events that are 0.01 inch or less.
3. Using a spreadsheet or simple statistical package, analyze the rainfall time series and develop a frequency distribution that can be used to determine the percentage of rainfall events less than or equal to a given numerical value (e.g., 0.2, 0.5, 1.0, 1.5 inches).
4. Construct a curve showing rainfall depth versus frequency, and create a table showing rainfall depth values for 50%, 75%, 90%, 95% and 99% frequencies.
5. Use the data to define the Water Quality storm event (90th or 95th percentile annual rainfall depth). This is the rainfall depth that should be treated through a combination of Runoff Reduction + Water Quality Treatment.
6. The data can also be used to develop criteria for Channel Protection. The 1-year storm (approximated in some areas by the 99% rainfall depth) is a good standard for analyzing downstream channel stability.
7. Other regional and national rainfall analysis such as TP-40, NOAA Atlas 14, or USGS should be used for rainfall depths or intensity greater than 1-year return frequency (e.g., 2-, 5-, 10-, 25-, 50-, or 100-year design storm recurrence intervals).

Relating Rainfall to Runoff: Soils & Land Cover

The amount of runoff generated by a given depth of rainfall on a particular site is governed by many factors, including rainfall intensity, slope, soils, land cover, and other factors. While there are many very sophisticated models for understanding the rainfall/runoff/water quality relationship (mostly used for detailed studies of particular watersheds), simplified methods are often used for stormwater criteria, BMP sizing, and for most stormwater compliance programs. Some simplifications include:

- As stated above, using average annual values for the target rainfall depth that relates most directly to protection of water quality. The 90th and 95th percentile storm event criteria are based on average annual values using the Rainfall Frequency Spectrum method detailed in **Box 2-2**.
- The relationship between rainfall and runoff can be expressed as a [Runoff Coefficient \(Rv\)](#). This is a unit-less value, similar to the Curve Number used in NRCS methods, and is based simply on modelled and empirical runoff from land uses under a wide range of conditions (e.g., slopes, compaction, and vegetation). **Table 2-5** shows Rv values derived from a variety of mainland sources for three land cover categories and the four Hydrologic Soil Groups (values may vary for specific tropical areas). **Table 2-6** provides guidance for how to categorize these three land covers for a given site.
- Pollutant loads are reduced by managing a particular volume of runoff. Many water quality criteria use [Water](#)

[Quality Volume \(WQ_v\)](#) or [Treatment Volume \(Tv\)](#) to express the volume of water that, when managed by a stormwater BMP, is regarded as providing adequate treatment. The theory is that if BMPs can be sized and designed to capture and treat this volume of water, then water quality protection is being optimized (it could be very difficult and very expensive for little gain to treat ALL the runoff in a given year).

Table 2-5. Land Cover Runoff Coefficients (Rv)

Land Cover	Hydrologic Soil Group			
	A	B	C	D
Forest Cover	.02	.03	.04	.05
Disturbed Soil/ Managed Turf	.15	.20	.22	.25
Impervious Cover	.95	.95	.95	.95



References: Pitt et al (2005), Lichter and Lindsey (1994), Schueler (2000), Legg et al (1996), Pitt et al (1999), Schueler (1987) and Cappiella et. al (2005).

Pulling it all together to Derive Storage Volumes for Water Quality Treatment

The next step involves computing how large the BMP (or BMPs) should be and the area and depth of various layers that provide storage (e.g., soil media for bioretention). This is the overall target volume needed to meet the performance standard(s), and, for the purposes of this method, is referred to as the [Treatment Volume \(Tv\)](#).

The equation in **Box 2-3** is one way to calculate the Tv. Various regulatory programs and stormwater manuals around the country contain multiple ways to calculate this volume, so the user should refer to applicable local manuals. This method is for water quality or volume reduction only, but other management may still be needed (e.g. channel protection, flood control).

Table 2-6. Land Cover Guidance for Calculating the Design Volume

Cover Type	Description	Island Example
<p>Impervious Cover</p>	<ul style="list-style-type: none"> • Roads, driveways, parking lots, sidewalks, patios, and other hardscapes. • Rooftops, with careful accounting for cistern use/drawdown. • Unpaved roadways, parking lots, and other surfaces on top of a compacted sub-base. • Surface area of “open water” stormwater BMPs, such as wet ponds. 	
<p>Disturbed Soil/ Managed Turf</p>	<p>Grassed areas that no longer function naturally due to disturbance, compaction, or excessive management:</p> <ul style="list-style-type: none"> • Turf areas intended to be mowed and maintained as turf within all land uses. • Road ROWs that will be mowed and maintained as turf. • Badlands or other areas where vegetative removal or other impact has altered hydrologic performance. 	
<p>Forest/ Preserved Open Space</p>	<p>Land that remains undisturbed OR will be restored to a hydrologically-functional state:</p> <ul style="list-style-type: none"> • Portions of residential yards that will NOT be disturbed during construction. • Portions of road ROW that, following construction, will be used as filter strips, grass channels, or stormwater treatment; MUST include soil restoration or use of engineered soil mix. • Community open space or ROW areas that will not be mowed routinely, but left in a natural vegetated state (can include areas bush hogged <u>several</u> times per year, but not frequently mowed). • Surface area of stormwater BMPs that are NOT wet ponds, have some type of vegetative cover, and that do not replace an otherwise impervious surface. • Other areas of existing forest and/or open space that will be protected during construction and that will remain undisturbed, including wetlands. 	

Box 2-3. Computation of the Target Treatment Volume

$$Tv = \frac{P \times (Rv_I \times \%I + Rv_T \times \%T + Rv_F \times \%F) \times DA}{12}$$

Where:

Tv = Target Treatment Volume, in acre-feet (cubic feet)

P = Depth of target rainfall event = 90th or 95th percentile rainfall depth (inches)

Rv_I = Volumetric Runoff Coefficient¹ for impervious cover (unit-less) = 0.95

$\%I$ = Percent of site in impervious cover (fraction)

Rv_T = Volumetric Runoff Coefficient¹ for turf cover or disturbed soils (unit-less)

$\%T$ = Percent of site in turf cover (fraction)

Rv_F = Volumetric Runoff Coefficient¹ for forest cover (unit-less)

$\%F$ = Percent of site in forest cover (fraction)

DA = Drainage area or site area (square feet)

¹See Table 2-5 for runoff coefficients for three land cover categories

Step 5. Allocate Storage to Various Components of Your BMP Design

Now that you know the overall Tv for the drainage area, you can allocate storage to one or several BMPs. If one single BMP cannot be designed to account for the Tv , then multiple BMPs can be used, and these BMPs can be designed to treat discrete “sub-areas” of the drainage area or be used “in series” (the runoff passes from one to the next downgradient BMP).

For the purposes of this methodology, the storage volume associated with an individual BMP will be referred to as the [Practice Volume \(\$Pv\$ \)](#). Therefore, if one BMP is used for a drainage area, the $Pv = Tv$ for the drainage area. If multiple BMPs are used: $Pv_1 + Pv_2 + Pv_3$, etc. = Tv for the drainage area.

Once this basic BMP design issue is addressed, you can figure out how much storage will be associated with various components of your BMPs, and thus BMP dimensions, such as depth and surface area.

It is important to note that many stormwater retrofit projects cannot account for the full Tv due to limited space, utilities, and other constraints. In these cases, it is important to establish a minimum threshold, such as treating at least 50% of the Tv .

To use an example of allocating storage, consider a project that will use a single Bioretention practice to treat runoff. For Bioretention, storage is allocated to:

- Ponded water on the surface
- Water stored within the pores of soil/compost media
- Water stored within the voids of coral stone and/or gravel layers

Accordingly, the surface area of the Bioretention will depend on the depth and volume of each layer, which are usually designed within margins prescribed by the specifications (e.g., the soil/compost layer must be at least 24"; surface ponding should be 6 – 12"). Some specifications state that at least 50% of the storage volume should be in the surface ponding layer.

To continue the Bioretention example, **Figure 2-1** shows a typical cross-section, void ratios associated with each layer, and the equation used for calculating the total Bioretention P_v . Other types of BMPs have similar methods and equations to account for the P_v . See, for example, the specifications in this guide in **Chapter 3** through **5**.

Step 6. Address Other BMP Design Elements

The final step in the BMP design process is to use the specifications to complete the design. Aside from BMP sizing and dimensions, these specifications typically address additional site feasibility issues, materials, design features such as pre-treatment and landscaping, typical details, calculations, and guidelines for construction and maintenance (see **Chapter 3** through **5**).

The product will be a BMP design package that includes drawings (cross-sections, profiles, plan view with relevant dimensions and elevations), and associated narrative and calculation documents.

Figure 2-1. Bioretention cross-section and equation for calculating the practice volume.

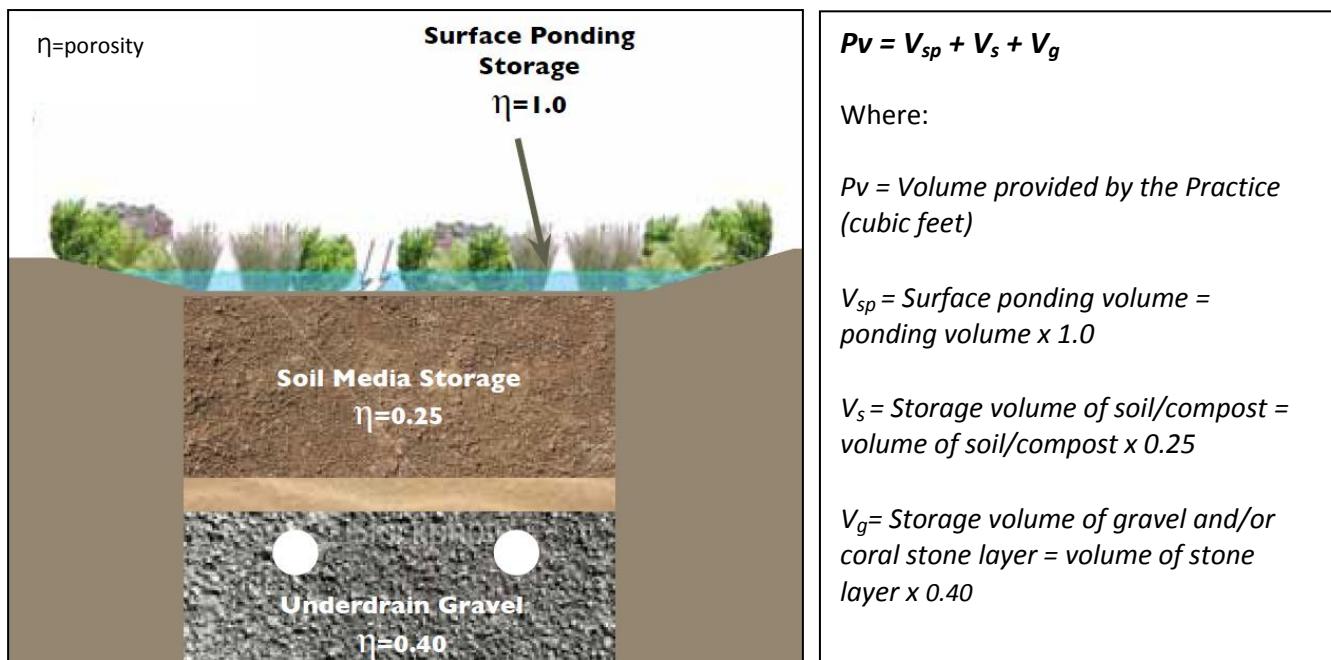



Rain garden installed for pavilion roof runoff at Santos Park in Guam (photo: GCMP)

Chapter 3.0

Using Vegetated Areas to Manage Stormwater

Most sites have areas of vegetation or turf grass that serve as aesthetic landscaping, barriers between parking stalls and driving aisles, buffers between adjacent land uses, or recreational open spaces. Many of these areas can also provide stormwater management benefits without compromising other functions or significantly increasing overall site maintenance costs. Plants can absorb a tremendous amount of water, take up pollutants, and transpire water vapor back into the atmosphere. Roots help water infiltrate into the ground and provide surface area for microbes that can remove contaminants. Soils can filter the runoff, removing pollutants before recharging the groundwater. Vegetation can also provide shade and cleaner air for humans, and habitat for wildlife.

In addition, as designers or practitioners interested in retrofitting an existing site, taking advantage of stormwater as a resource that can reduce irrigation costs and increase plant survival can be a winning strategy—particularly if your site is on the dry side of the island or if you are limited in your vegetation options due to seasonal rainfall patterns. Existing open spaces can offer the ideal locations for cost-effective stormwater retrofits; in some cases, all you need is a shovel, some plants, and a few friends!

This chapter aims to help you envision the typical vegetated areas at a site as multi-functional landscapes integral to LID objectives.



Plants used at a rain garden demonstration project in Garapan, Saipan

Seizing the Opportunity

When designing the “green” space at a new development or retrofitting existing vegetated areas, consider one of the following strategies for incorporating LID:

- 1. Preserve more green!** The best way to minimize runoff at an undeveloped site is to preserve natural areas right from the start. Mature trees and undisturbed soils help to maintain the natural hydrology of the area, as well as providing instant shade and habitat, rather than waiting for newly planted trees to grow. Designating these areas needs to happen early in the design stage and be clearly marked in the field to ensure preservation actually takes place. Some additional tax benefits may be available if conservation restrictions are placed on these preserved areas.
- 2. Disconnect impervious cover** by directing runoff to vegetated areas for stormwater recharge and landscape irrigation. Runoff from small impervious areas (e.g., portions of rooftops, driveways, and sidewalks) can sometimes be managed just by providing sheet flow into adjacent landscaping. This non-structural technique helps to reduce the size and cost of the necessary structural BMPs for the site.
- 3. Integrate landscaping and stormwater management** by using vegetated stormwater BMPs throughout the site in areas that would typically be landscaping (e.g., parking lot islands, grass strips between the sidewalk and road, and the vegetated areas near downspouts and patios). This helps to treat runoff for improved water quality

recharge, and evapotranspiration without sacrificing additional space or increasing maintenance effort beyond typical landscaping requirements.

- 4. Upgrade vegetation and soils** by converting turf grass areas or high maintenance landscaping (i.e., requires fertilizers, pesticides, and irrigation) to native trees, shrubs, and grasses. Because native plants are more adapted to a specific island climate, this switch will reduce the amount of water and chemicals needed on your site. In addition, native plants (particularly trees and shrubs) tend to have extensive canopy and root systems that can improve infiltration, take up nutrients, and intercept and evaporate more rainwater than a typical lawn. Of course, they also add aesthetics, shade, and wildlife habitat.

Table 3-1 summarizes common LID options for better utilizing vegetated areas, applying one or more of the above strategies. The remainder of this chapter focuses on **Strategy #3**.



This rain garden at He'eia State Park on Oahu was designed and installed by Hui o Ko'olaupoko and other watershed volunteers.

Table 3-1. Seizing the Opportunity – Vegetated Areas





LID Strategy	Applications	Island Example
<p>1. Preserve more green</p>	<ul style="list-style-type: none"> • Applicable at site design stage, since the areas to be preserved need to be clearly marked on the plans and in the field. • Preserved mature trees and undisturbed soils help to promote infiltration, evapotranspiration, and stabilization of steep slopes. • May be required on the local level to some extent. May be able to achieve flexibility with other site design aspects (e.g., density) in exchange for preserving critical areas at a site. 	
<p>2. Disconnect impervious cover – directing runoff from small impervious areas into landscaping</p>	<ul style="list-style-type: none"> • Stormwater runoff is much more manageable in small doses. Prevent large flow concentration and high velocities by slightly adjusting grades or breaking up flow paths (e.g., speed bumps, dips) and direct to stabilized vegetated areas. • Can help to irrigate plantings, particularly helpful in drier areas where every drop will help. 	
<p>3. Integrate landscaping and stormwater management by incorporating BMPs in areas that are typically vegetated anyways.</p>	<ul style="list-style-type: none"> • Use your land efficiently by creating showpiece stormwater BMPs at your site entrance instead of the typical mounded landscaping. • Convert existing landscapes and turf areas into vegetated BMPs by taking advantage of existing low points and flow paths. Use simple diversion techniques to redirect runoff where needed (e.g., speed bumps, dips, trench drains). 	
<p>4. Upgrade vegetation by replanting lawn areas and other open spaces with native species.</p>	<ul style="list-style-type: none"> • Native vegetation is well suited to your local climate, and so it will be less expensive to maintain while providing great stormwater benefit. • Revegetating turf with native trees, shrubs, and grasses will also help to stabilize your site during the wet and/or windy season, as well as provide shade and habitat. • There are native plant initiatives on many islands where you can get more information on the benefits and where to get them. 	

Figure 3-1. Incorporating LID into Landscaped Areas



This curbed grassed island separating portions of the parking lot at the hospital in Garapan is a wasted opportunity for parking lot design and for stormwater management.



Before, this grassed road median separated the main road from the parking area. Runoff from the parking lot and the road ponded along the edge, dropping sediment and other debris.



Seize the opportunity to apply LID like they did here:

1. Lose the curbing and create landscape depressions that can accept stormwater runoff from the parking surface.
2. Plant some trees that can help soak up water, provide some shade, and look nice.
3. Use native plants to reduce maintenance and upkeep requirements.



Seize the opportunity to apply LID and fix a localized drainage problem. They did!



1. Installation of a rain garden at this location helped with the drainage along the roadway
2. Use of local plants was a “test” to determine which plants grew the best and required the least maintenance.

Island Vegetated BMP Options

There are a number of BMPs that can be integrated into vegetated features (see **Table 3-2**). These BMPs are very similar and function in much the same way. In general, stormwater is temporarily stored on the surface, then filtered through soil, and taken up by vegetation. The different practices and variants provide an array of options that the designer can choose from based on the land use, treatment objective, and specific site constraints and features. **Figure 3-1** shows concepts and examples of re-envisioning landscaping to incorporate stormwater management.

This chapter focuses on the most common of these, which are the bioretention area and the rain garden. The main difference is that rain gardens are very simple depressions with plants, and possibly some soil amendments, whereas bioretention areas are more engineered and tend to have more complex soils, inlets, and outlets. Since they are more complex, the detailed specifications later in this chapter focus on bioretention and adapting mainland materials to the tropical island environment.

Table 3-2. Typical BMPs used in vegetated areas

BMP		Applications	Example
Primary	Bioretention —vegetated depression with specific soil mix and structural components such as an underdrain system, overflow structure, etc.	<ul style="list-style-type: none"> • Generally, used at commercial or institutional properties • Good for places where landscaped amenities are important • Can be designed for infiltration or filtering, depending on underlying soils • Flexible geometry – can be designed to fit the site 	
Variants	Rain Garden —no underdrain, native soils, or only modest soil amendments	<ul style="list-style-type: none"> • Smaller-scale, for residential or small commercial properties • Good for managing roof runoff • If used for driveway and/or small parking lot runoff, maintenance may be higher due to greater pollutant load • Easy for homeowners to design and construct • Good for places where landscaped amenities are important 	
	Island stone bioretention —lava rock or limestone at surface rather than mulch	Used in places where mulch is hard to find or stone is the aesthetic priority.	

BMP		Applications	Example
	Planter Box —elevated bioretention in a box	<ul style="list-style-type: none"> • Typically located at base of building downspout • Good for commercial developments where landscaped planters are already used • Many easy retrofits are possible at existing businesses and schools where downspouts already discharge into or near planters 	
	Tree pit —allow street trees to do double-duty	<ul style="list-style-type: none"> • Typically in road ROW or along parking areas • Use curb inlets or curb cuts to direct runoff into tree pit with engineered soil mix for high filtration. • Overflows typically directed into existing storm drain system 	
Primary	Bioswale —long, skinny version of bioretention; can have longitudinal slope	<ul style="list-style-type: none"> • Can be used in road ROW, conveyance system, or parking lot medians • Maintenance is mainly mowing • Vegetation can be turf or landscaped similar to bioretention 	
Variants	Wet swale —used to convey, treat, and evaporate runoff	<ul style="list-style-type: none"> • Good for places where groundwater is close to the surface • Plant with wetland vegetation • Design for habitat creation to minimize mosquitoes 	
Primary	Grass infiltration bed —stone infiltration bed covered by grass	<ul style="list-style-type: none"> • Can hide under ball fields, parks, and other grassed areas with minimal vehicular traffic • Vegetative maintenance low, but have to include observation and clean out ports to monitor and prevent clogging 	



Opportunity to disconnect impervious cover! Existing drainage pipe discharges directly to stream (white dashed line), LID approach would be to redirect a portion of drainage as sheet flow into the adjacent vegetated field to treat runoff instead.



This community ball park has drainage issues, but also offers a great opportunity to install a bioswale along the outside rim of the field.



Road right-of-ways are good places to install vegetated or bioswales to help infiltrate and clean road runoff.



Tree boxes along walkways can help trees and improve water quality!

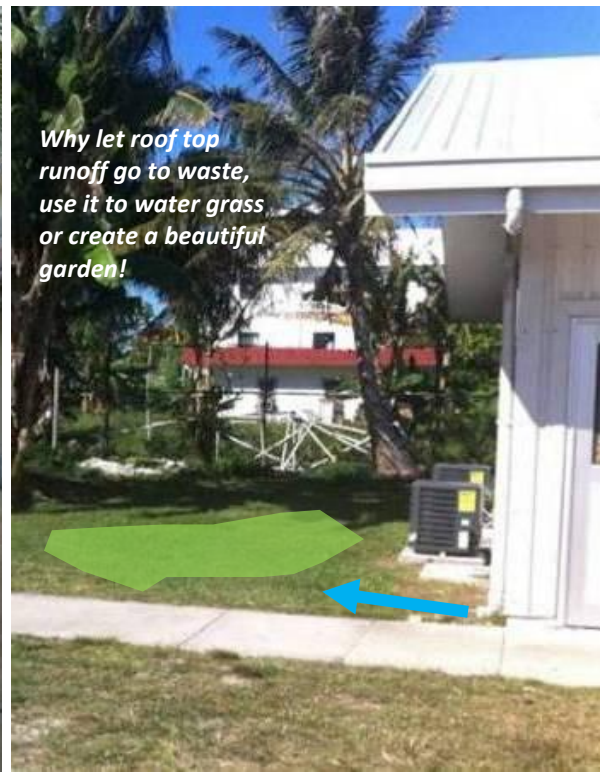

Why let roof top runoff go to waste, use it to water grass or create a beautiful garden!



An existing PVC pipe under the sidewalk could be redirected so that dirty runoff at this housing complex flows to pervious area or rain garden.



This poor planter box is begging for a little aloha. Set it free from sediment and children's feet. What an easy retrofit, it already has inlets and outlets.

For new development projects, you will want to consider the dimensions of the available landscape area and how much impervious area will be draining to the BMP, soil conditions, and how water gets into and out of the BMP. The types of plants that do well in these practices must tolerate wet and dry conditions due to continuous fluctuations in water level. In existing developed areas, you will find that many landscaped areas are elevated above pavements, lined by curbing, are compacted, contaminated, or are otherwise situated to shed runoff rather than accept it. In some cases, these areas can be adjusted with simple re-grading or removing the curb. However, location is important, as you will want to pick a low area that has an uphill drainage area flowing to it.

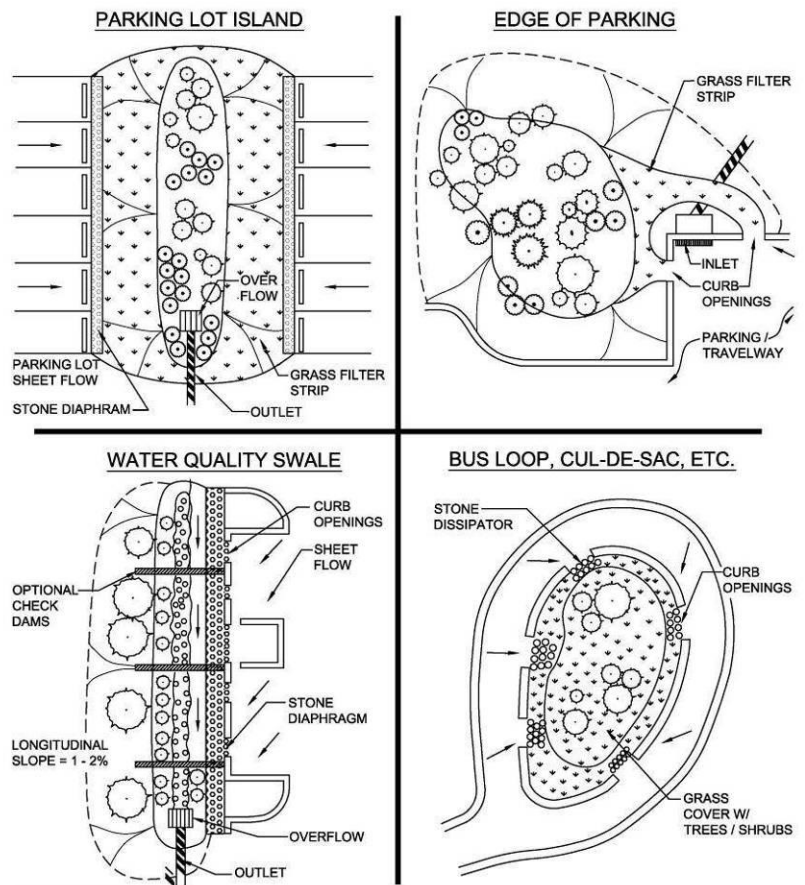

Example bioretention applications in four different landscaped areas ranging from parking lots to turnarounds.

Island Bioretention

Bioretention is a suitable practice for most island land uses, as long as the drainage area is limited to about five acres. Common bioretention opportunities include landscaping islands, cul-de-sacs, parking lot margins, commercial setbacks, and street-scapes (i.e., between the curb and sidewalk). Bioretention is extremely versatile because of its ability to be incorporated into landscaped areas. Existing stormwater design manuals for Honolulu, CNMI, Guam, and Palau all include bioretention design information.

Bioretention was developed in the Mid-Atlantic area of the continental US and was originally designed to replicate the pollutant removal mechanisms of a forested ecosystem. Since that time, the concept has been adapted to other regions and

climates. This specification adapts the concept of bioretention to the tropical island environment. The adaptations involve substituting native materials for filter bed components that are unavailable and would be expensive to import, modifying designs to account for wet and dry seasons, and specifying locally-available plant materials.

There are three basic design adaptations for bioretention presented here. The first is the simplest, a rain garden. The other adaptations are for installations with or without an underdrain system using rock or limestone-based (coral stone) materials in the bedding layers. **Coral stone bioretention facilities require special designs for placement of soil media to prevent pH changes and clogging.**

1. Rain gardens (no stone layer or underdrain): Simplest variant of the bioretention, using amended native soils only for the planting soil media (**Figure 3.2**).

2. Infiltration Design (no underdrain): Design *without* an underdrain for sites where soil testing indicates suitable infiltration rates, greater depth to groundwater, and a low risk of groundwater contamination (e.g., not located at a stormwater hotspot). **Figures 3.3** and **3.4** provide typical details for infiltration designs. **Figure 3.3** is a typical design for locations where the soil/compost mix is available and/or can be produced from local materials. **Figure 3.4** provides a design alternative where availability of soil/compost is limited or is expensive, and coral stone is substituted for some of the surface area (although some soil/compost is still needed). Also note that **Figure 3.4** shows a parking lot island application, but many other configurations (e.g., edge of parking lot, turnarounds, etc.) are also encouraged.

3. Filter Design (with underdrain): Design with an underdrain for sites where native soils do not percolate as readily (less than ½ inch per hour). These designs still incorporate some level of infiltration, especially during the dry season by providing a stone “sump” below the



Bioretention design adaptations are based on underdrains and stone material: coral stone (top) and volcanic rock (bottom).

underdrain pipe. See **Figures 3.3** and **3.5** for details of the filter design. Once again, the parking lot island is used for the typical detail, but other configurations do exist. As above, **Figure 3.3** applies where the soil/compost is generally available, and **Figure 3.5** where coral stone is used to replace some of this material.

Table 3-3 provides details and notes for each of the island bioretention design components shown in the typical details.

Figure 3-2. Longitudinal section for a rain garden.

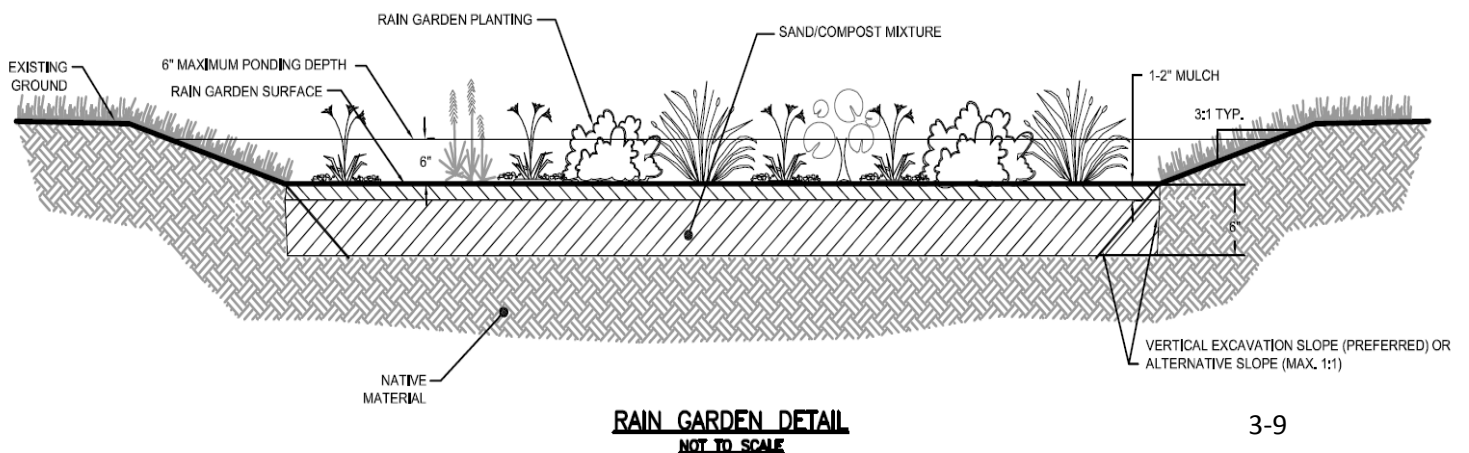

Figure 3-3. Plan view (top) and longitudinal sections for a bioretention without (middle) and with (bottom) an underdrain.

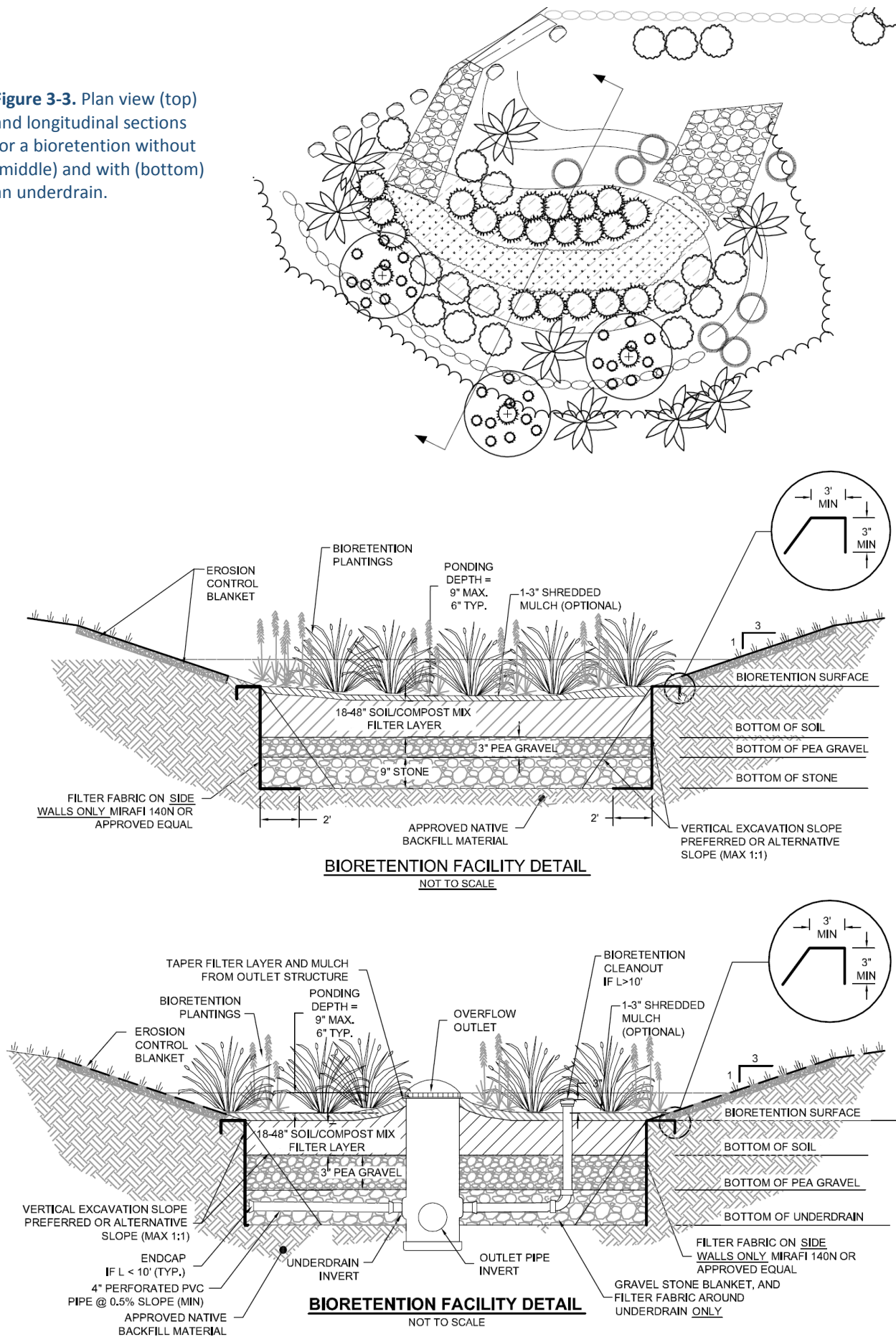

Figure 3-4. Bioretention (no underdrain) using coral stone to replace SOME of the soil/compost mix.

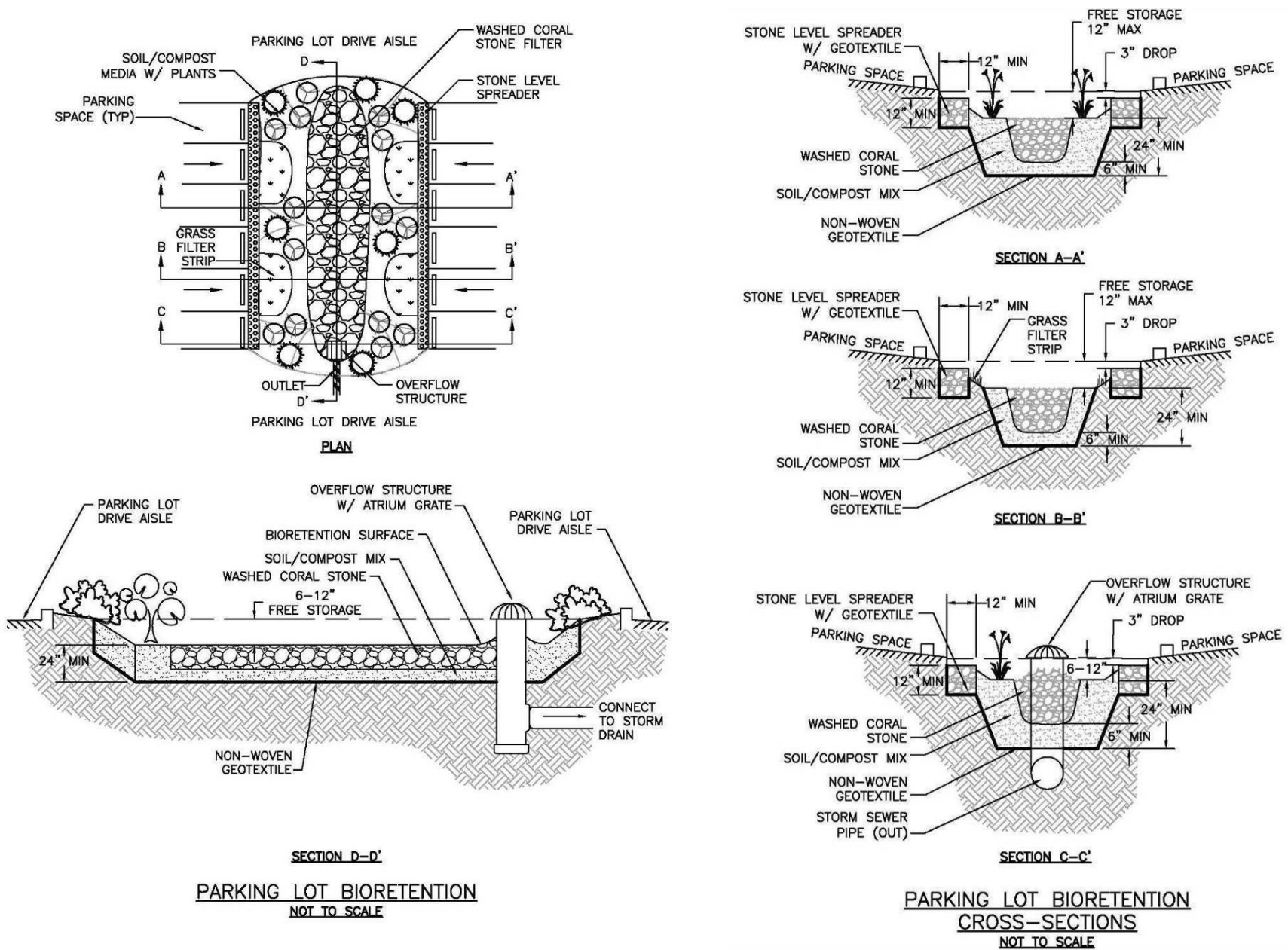

Figure 3-5. Bioretention (with underdrain) using coral stone to replace some of the soil/compost mix.

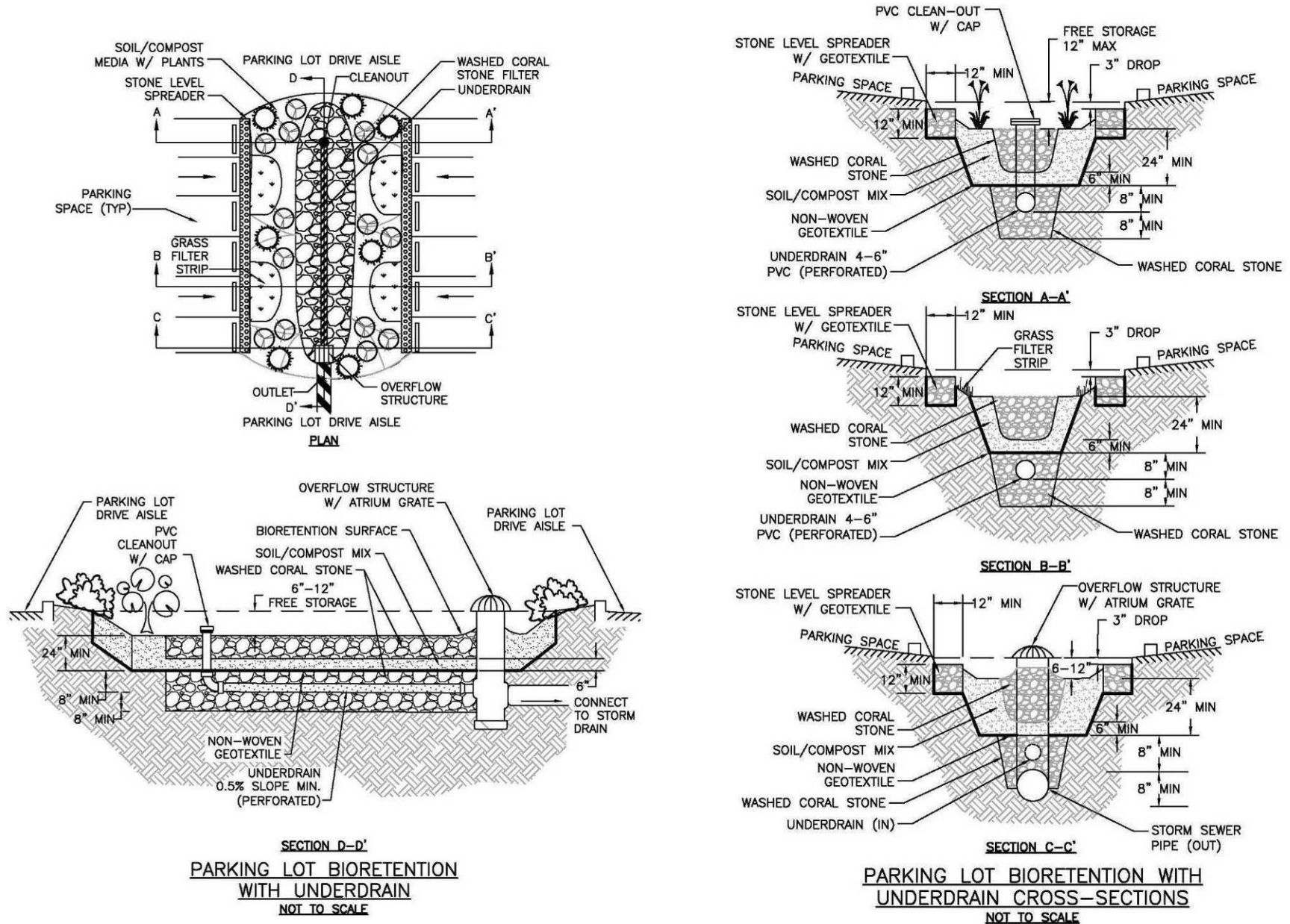

Table 3-3. Description of Bioretention Design Components

Material	Specification	Notes
Stone Level Spreader	<ul style="list-style-type: none"> • Clean, washed coral or volcanic stone, sized for inflow rate • Minimum 12" wide & 12" deep • Non-woven geotextile underneath • Top of stone 3" below pavement elevation • Construct in concrete box if drainage area >1 acre 	See pretreatment section below for other options. Larger drainage areas and inflow rates may require pretreatment cell or stone forebay
Grass Filter Strip	<ul style="list-style-type: none"> • Minimum 2' wide • 5:1 maximum slope • Does NOT need soil/compost mix underneath 	Grass filter strips help with pretreatment and can also be used to increase ponding surface area to enhance free storage. As shown in Figure 3.3 , the grass filter strip can be used as an alternative to the Stone Level Spreader for some applications.
Free Storage Above Filter Bed	6 – 12", with 6" recommended	Control ponding level with overflow structure, or by-pass higher flows to drop inlet in parking lot
Soil/Compost Media	<ul style="list-style-type: none"> • Follow guidance in Soil Compost Media specification in Appendix C • For Figures 3.4 and 3.5, place on sides and underneath coral stone filter so that all flow passes through soil/compost; minimum thickness of 6" below coral stone • For Figure 3.3 design, soil/compost covers entire underdrain layer (no coral stone) 	Other compost media or sand mixtures may be substituted if tested and approved by the plan-approving authority. Use of compost may lead to elevated phosphorus concentrations at the outflow.
Coral Stone Filter	<ul style="list-style-type: none"> • Clean, washed coral stone; minimize amount of coral "dust" (very fine particles) • For Figures 3.4 and 3.5, bed within soil/compost layer; coral stone surface area ≤ 40% of total filter bed surface area 	All flow that passes through coral stone should also pass through soil/compost mix to lower pH and reduce chance of heavy metal leaching
Overflow Structure	<ul style="list-style-type: none"> • Sized for 10-year storm peak intensity and discharge • Can be reduced by using off-line design • Structure scaled to application (e.g., yard inlet, commercial structure) 	Off-line designs are encouraged to prevent wet season and intense flows from damaging the filter bed (see section below on Key Design Considerations)
Geotextile	<ul style="list-style-type: none"> • Needle-punched, non-woven geotextile fabric with a flow rate > 110 gal./min./sq. ft. (e.g., Geotex 351 or equivalent) • Place as shown on typical details 	More impermeable liners may be needed at facility invert for hotspot land uses or in close proximity to drinking water sources; do NOT place impermeable liners between soil/compost and underdrain stone
Underdrains & Cleanouts (only for underdrain designs)	<ul style="list-style-type: none"> • 4 – 6" inch rigid schedule 40 PVC pipe (or equivalent corrugated HDPE for small applications) • 3/8" perforations at 6 inches on center • Perforations only below filter bed • Minimum slope = 0.5% (steep slopes make construction difficult) • Position underdrain pipes ≤ 20' apart • Clean-outs non-perforated & tied to underdrain with elbow; all clean-outs capped at surface 	Lay the perforated pipe under the length of the bioretention cell, and install non-perforated pipe as needed to connect with the storm drain system. Install T's and Y's as needed, depending on the underdrain configuration. Extend cleanout pipes to the surface with vented caps.

Material	Specification	Notes
Underdrain Stone (only for underdrain designs)	<ul style="list-style-type: none"> • Clean, washed coral or volcanic stone; minimize amount of coral “dust” (very fine particles) • Place underdrain pipe in top 8” of underdrain stone • Provide ≥ 8” of stone below invert of underdrain pipe to serve as dry season infiltration sump 	Dry season infiltration sump will allow some infiltration, even with relatively poor soils
Plant Materials	<p>Plant mix of herbaceous, shrub, and tree species from plant list, see Appendix B.</p> <p>Establish plant materials as specified in the landscaping plan.</p>	In general, plant spacing must be sufficient to ensure the plant material achieves 50% cover in the proposed planting areas within a 2-year period (with non-stop growing season, over-growth is a bigger concern, so don’t try to achieve complete coverage in the short-term). Watch for areas of exposed, erodible soils however. It is recommended to plant trees around the perimeter of bioretention, so trees drop vegetative matter on the filter surface to provide for “self-mulching.”

Island Bioretention Sizing

The system should be sized to meet overall treatment objectives. See **Chapter 2** for a suggested methodology for identifying performance standards and treatment objectives, and translating these into a

target volume for the BMP. Based on the terminology of **Practice Volume (P_v)** used in **Chapter 2, Box 3-1** outlines the storage volume provided by each layer of the practice.

Box 3-1. Sizing Vegetated BMPs to Meet Treatment Objectives

The Practice Volume (P_v) is the storage provided by the practice to meet water quality or runoff reduction goals. See Chapter 2 for the overall methodology for determining the P_v .

Vegetated BMP Design:

$$P_v \leq 0.75 (V_{sp} + V_s + V_g)$$

Where:

P_v = Total Practice Volume (cubic feet)

V_{sp} = Storage volume of surface ponding or free storage = free storage volume x 1.0 (cubic feet)

V_s = Storage volume of soil/compost = volume of soil/compost x 0.25 (cubic feet)

V_g = Storage volume of gravel/stone underdrain layer = stone underdrain layer volume x 0.40 (cubic feet)

The P_v can be increased by adding additional ponding area beyond the filter bed surface (**Figure 3.6**). General surface area guidelines are as follows:

- Total surface area = 3% to 6% of the contributing drainage area
- Filter bed surface ≥ 75% of total surface area; additional ponding area ≤ 25% of total surface area
- For designs with coral stone (**Figures 3.4 & 3.5**), Filter Bed Surface Area ≥ 60% Soil/Compost & ≤ 40% Coral Stone

Unique Island Factors

The most important component of a bioretention is also the part that is the most difficult to get right on the islands: the soil/compost media. On the mainland, materials like coarse sand and compost may be common. On many islands, however, these materials can be elusive. Surprisingly, even with such high growth rates and with large amounts of vegetated waste, compost facilities are not common, and limestone-derived “sand” is much more prevalent than coarse sand. Designers should use the compost specification in Appendix C and ensure that the contractor understands that pulverized limestone “powder” should not be used for “sand.” As these BMPs become more common, niche markets around these materials will arise, and make construction much easier.

Another unique aspect of island implementation is how to choose the right plants. On the mainland, many studies have been done to determine which plants can tolerate both the wet and dry conditions in a bioretention practice. These studies are just starting on the islands, so the data is currently limited. **Appendix B** provides a starting point, but island practitioners should reach out to local plant experts and colleagues from neighboring islands to learn which plants are the most viable for bioretention.

Island bioretention applications are few and far between, so reach out to your fellow LID designers to learn from each other which locally available plants will thrive in the BMP and which to avoid.

Key Design Considerations

The following considerations and design guidance are important when planning and implementing bioretentions.

Available Space. Designers can assess the feasibility of using bioretention facilities based on a simple relationship between the contributing drainage area (CDA) and the corresponding bioretention surface area. The total bioretention surface area will be approximately 3% to 6% of the contributing drainage area, depending on the imperviousness of the CDA and the depth of the filter layers. The total surface can include the filter bed area plus additional ponding area, as noted in the sizing section and **Figure 3.6**.

Site Topography. Bioretention is best applied when the grade of contributing slopes is greater than 1% and less than 5%.

Available Hydraulic Head. Bioretention is fundamentally constrained by the invert elevation of the existing conveyance system to which the practice discharges (i.e., the bottom elevation needed to tie the underdrain from the bioretention area into the storm drain system or to discharge at grade). In general, 3 to 4 feet of elevation above this invert is needed to create the hydraulic head needed to drive stormwater through a proposed bioretention filter bed. Less hydraulic head is needed if the underlying soils are permeable enough to dispense with the underdrain.

Water Table and Bedrock. Bioretention should generally be separated from the water table and bedrock to ensure that groundwater does not intersect the filter bed. Mixing can lead to possible

groundwater contamination or failure of the bioretention facility. A separation distance of 2 feet is recommended between the bottom of the excavated bioretention area and the seasonally high ground water table or bedrock layer.

Utilities. Designers should ensure that future tree canopy growth in the bioretention area will not interfere with existing overhead utility lines. Interference with underground utilities should also be avoided, particularly sewer lines. Local utility design guidance should be consulted in order to determine the horizontal and vertical clearance required between stormwater infrastructure and other dry and wet utility lines.

Soils. Soil conditions do not constrain the use of bioretention, although they determine whether an underdrain is needed. Soils with slow percolation rates in Hydrologic Soil Groups (HSG) C or D usually

require an underdrain, whereas HSG A or B soils generally do not. When designing a bioretention practice, designers should verify soil permeability by using the on-site soil investigation methods outlined in **Appendix D**.

Contributing Drainage Area. Bioretention cells work best with smaller contributing drainage areas, where it is easier to achieve flow distribution over the filter bed. Typical drainage area size can range from 0.1 to 2.5 acres and consist of up to 100% impervious cover. The recommended maximum drainage area to a single bioretention area is 5 acres. However, it is strongly recommended that drainage areas be “broken up” through site grading so that each bioretention area receives less than 2.5 acres of drainage (and, therefore, a site may have more than one bioretention area).

Figure 3-6. P_v can be increased by adding additional ponding area beyond the filter bed surface area, as long as the filter bed constitutes at least 75% of the total ponding surface area.

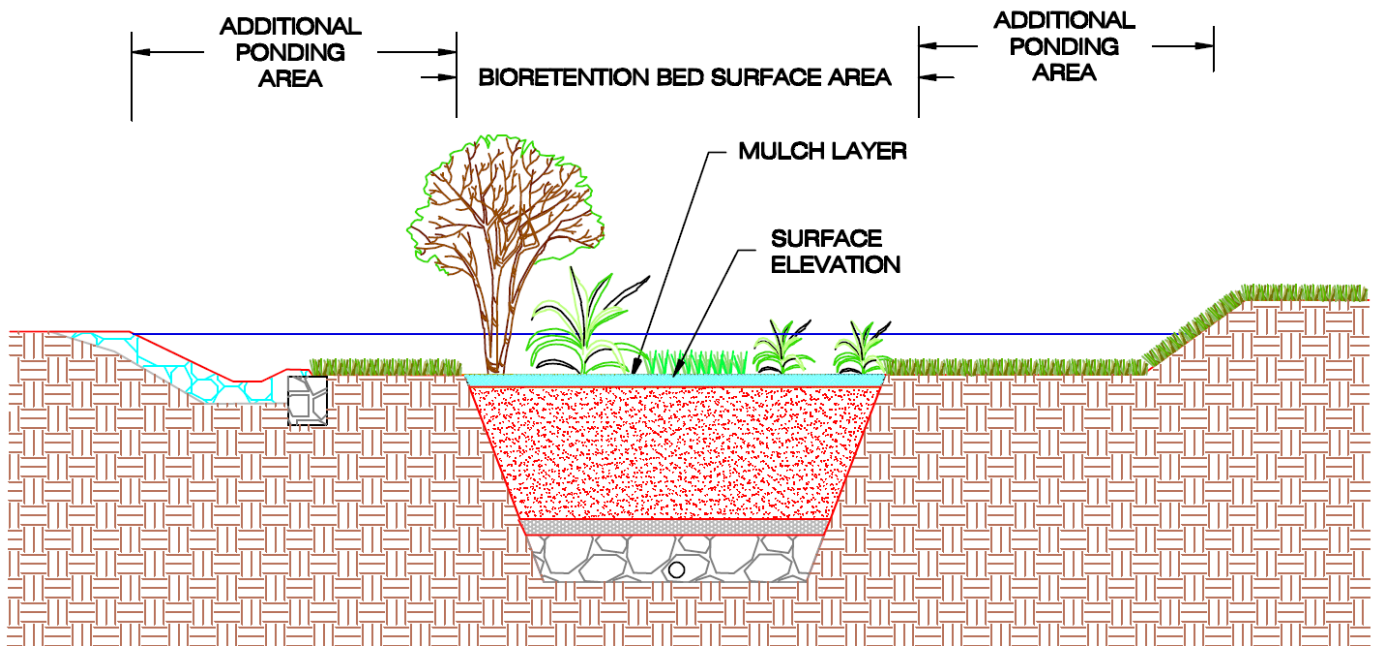

Hotspot Land Uses. Runoff from hotspot land uses should not be treated with infiltrating bioretention (i.e., constructed *without* an underdrain).

Floodplains. Bioretention areas should be constructed outside the limits of the 100-year floodplain.

No Irrigation or Baseflow. The planned bioretention area should not receive baseflow from springs, irrigation water (except during the initial plant establishment period), chlorinated wash-water or other such non-stormwater flows.

Setbacks. To avoid the risk of seepage, do not allow bioretention areas to be hydraulically connected to structure foundations or pavement. At a minimum, bioretention areas should be located a horizontal distance of 100 feet from any water supply well, 50 feet from septic systems, and 5 feet from down-gradient wet utility lines. Dry utility lines such as gas, electric, cable and telephone may cross under bioretention areas if they are double-cased.

Aesthetics. Bioretention area locations should be integrated into the site planning process, and aesthetic considerations should be taken into account in their siting and design.

Pretreatment. Figures 3.3 through 3.6 illustrate a stone level spreader or inflow channel between the parking lot and the filter bed. This spreader or channel is designed to evenly spread flows across the filter bed surface and should be sized for the expected rate of inflow. If the contributing drainage area exceeds 1 acre, then the stone level spreader should be

contained in a concrete-lined trench box (instead of the geotextile shown in the figures). The figures also show that the top of the stone spreader is 3" lower than the edge of the pavement. This is designed to prevent clogging and build-up of sediment and vegetation where the parking lot edge meets the stone, which could ultimately lead to bypassing of the facility. Depending on the type and scale of the application, other pretreatment options may be desired, such as:

- **Pretreatment forebay** (for larger drainage areas and inflows): a separate cell or sump at the BMP inlet location. Collectively, pretreatment cells should have a storage volume equivalent to at least 10% of the Practice Volume. The cells may be formed by a concrete weir, a stone check dam, or an earthen berm (**Figure 3.7**) and may include an energy dissipator. **Timber weirs can be used, but may not have longevity in tropical climates.** Pretreatment cells do not need underlying soil/compost mix, in contrast to the main bioretention cell. If the pretreatment cell will be on or close to bedrock, or another media that will rapidly infiltrate, the pretreatment cell should be lined so that by-passing of the filter bed does not occur.
- **Grass Filter Strips or Grass Channels** (for relatively small drainage areas and inflows): Grass filter strips extend a minimum of 5 feet from edge of pavement to the filter bed and have a maximum slope of 20% (5:1). Grass channels designed to convey the water quality volume can also be used.
- **Proprietary Structure**: An approved structure with demonstrated capability of reducing sediment and hydrocarbons.



Grass pretreatment channel leading from parking lot to bioretention.



Stone sump at pipe inlet for energy dissipation and sediment capture in newly constructed Maui rain garden.



Use of underground proprietary device prior to bioretention on the Big Island of Hawaii.



Stepped inlet channel to trap sediment prior to flow entering bioretention in Pago Pago, AS. (photo: Brian Rippey)



Wide grass filter strips as parking provide pretreatment.



Concrete weir created from old curbing used to create sediment forebay for this bioretention on Martha's Vineyard, MA



Paved concrete flume used as pond pretreatment in St. John, USVI.

Figure 3.7. Example details for earthen berm, stone check, and timber (or concrete) weirs used to create a pretreatment forebay.

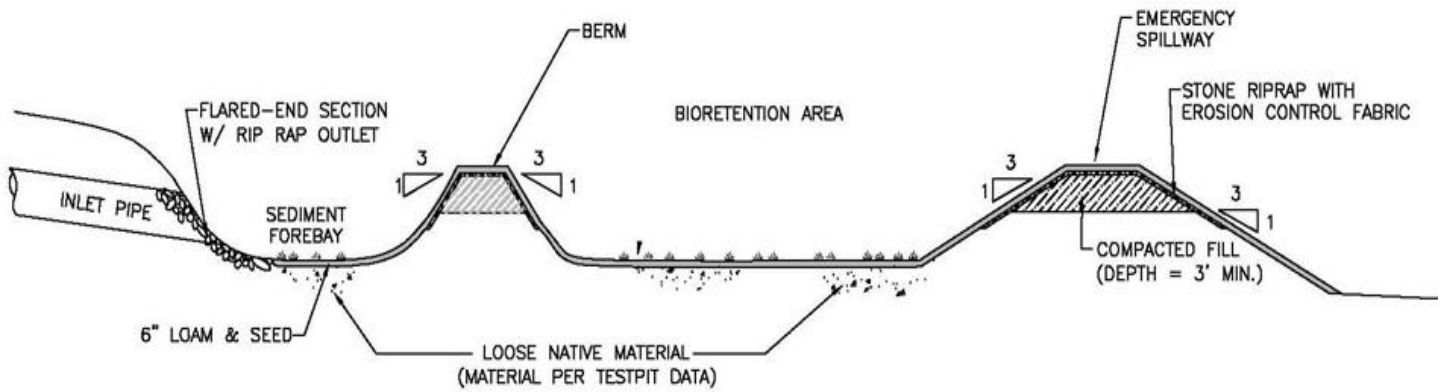

**TYPICAL SECTION THROUGH
BIORETENTION**
NOT TO SCALE

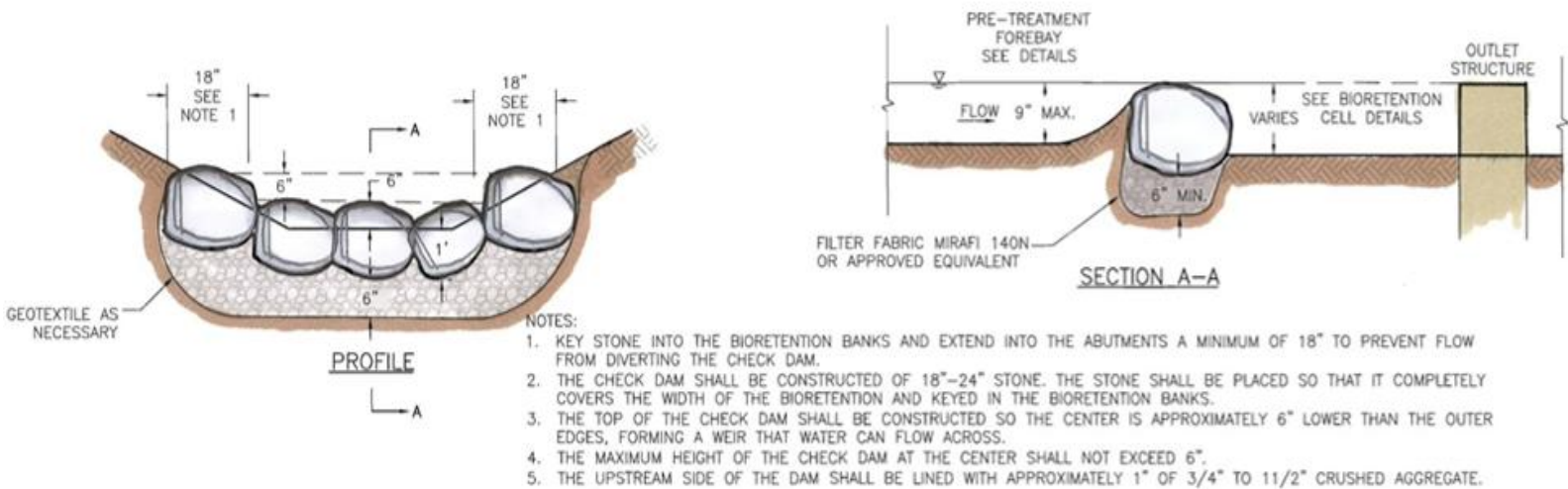

**STONE CHECK FOR BIORETENTION
TYPICAL DETAIL**
NOT TO SCALE

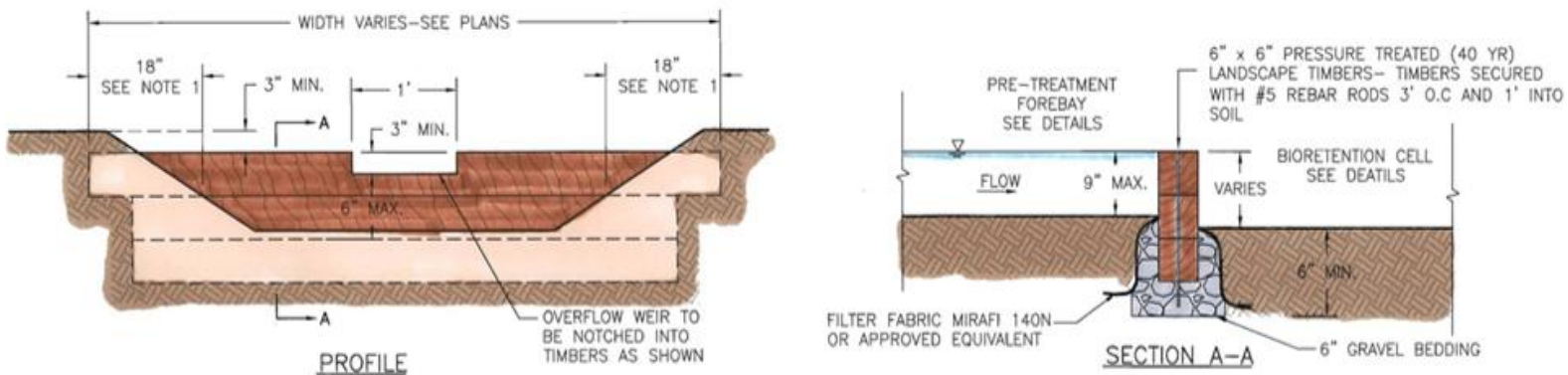

- NOTES:**
1. KEY TIMBERS INTO THE SWALE BANKS AND EXTEND INTO THE ABUTMENTS A MINIMUM OF 18" TO PREVENT FLOW FROM DIVERTING THE CHECK DAM.
 2. THE MINIMUM DESIGN CAPACITY SHALL CONVEY A 2 YEAR-24 HOUR PEAK FLOW.

**TIMBER CHECK FOR BIORETENTION
TYPICAL DETAIL**
NOT TO SCALE

Conveyance for Larger Storms. There are two options for conveying water into the bioretention area: **on-line** and **off-line** systems. In on-line systems, all the runoff volume is conveyed into and through the bioretention. An overflow structure should always be incorporated into on-line designs to safely convey larger storms (storms larger than the target Practice Volume) through the bioretention area. The following criteria apply to overflow structures:

- The overflow structure should be designed to manage the peak rainfall intensity and flow for the 10-year storm. Energy dissipators should be used so that velocities are non-erosive at the outlet point (i.e., to prevent downstream erosion). The overflow structure does not have to be in the filter bed itself, but can be at the edge of the filter bed or on the side slope (see **Figures 3.3** and **3.5**).
- Common overflow systems within bioretention practices consist of a drain-inlet structure, where the top of the structure is placed at the maximum ponding elevation, typically 6 to 12 inches above the surface of the filter bed (6 inches ponding depth preferred).
- The overflow capture device should be scaled to the application – this may be a landscape or yard drain for small applications or a commercial-type structure for larger systems.
- The filter bed surface should generally be flat so the bioretention area fills up like a bathtub.

Off-line systems “split” the flow up-gradient from the bioretention so that only design flows associated with the Practice Volume enter the facility. This option is preferred,

especially since wet season flows can easily surpass the treatment capacity of the bioretention area, and these flows can damage the inlet points, filter bed, and other components. One common approach is to create an alternate flow path at the inflow point into the structure such that when the maximum ponding depth is reached, the incoming flow is diverted past the facility (such as into a drop inlet in the adjacent parking lot). In this case, the higher flows do not pass over the filter bed and through the facility, but additional flow is able to enter as the ponded water infiltrates through the soil media.

Another option is to utilize a low-flow diversion or flow splitter at or above the inlet to allow only the design flow associated with the Practice Volume to enter the facility, while larger flows bypass the bioretention area altogether. This may be achieved with a weir, curb opening sized for the target flow, or a flow-splitting structure (for instance, in a manhole), in combination with a bypass channel.

Soil/Compost Media. It will be necessary to find a suitable soil/compost mix for Island Bioretention. This mix will likely come from a topsoil vendor or other local source. Guidelines for creating and testing the soil/compost mix are detailed in **Appendix C** specification.

Infiltration Rate Testing for Infiltration. For designs that do NOT include an underdrain, it will be necessary to conduct infiltration testing to determine infiltration suitability. If underlying soils are not suitable for infiltration, the underdrain design should be used. Guidelines for conducting the infiltration test are included in **Appendix D**.

Maintenance. Maintenance is a crucial element to ensure the long-term performance of bioretention. The most frequently cited maintenance problems are inlet clogging and erosion, sedimentation of the filter bed, and inadequate management of vegetation. Other than removing sediment and other trash, the main task that needs to be regularly performed is typical plant maintenance, such as removing dead or dying plant material, cutting back overgrown vegetation, and mulching occasionally to help prevent weeds and retain moisture.



Maintenance activities for vegetated BMPs include: watering after installation until plants are fully established; and weeding, particularly during the first year.

Table 3-4 provides suggested annual maintenance inspection points to evaluate the condition and performance of the practice and remedial actions.

Table 3-4. Recommended Maintenance for Vegetated BMPs

Maintenance Activity	Schedule
<ul style="list-style-type: none"> Pruning and weeding to maintain appearance. Remove overgrowth of plant materials. Remove plant debris that seems to be clogging the filter bed. Remove trash and debris. Water plants during dry season, if necessary. Check and rectify standing water, insect habitat. 	As needed
<ul style="list-style-type: none"> Inspect inflow points for clogging. Remove build-up of sediment and debris. Inspect overflow structure and remove sediment and debris. Inspect plant materials for survival and replace any dead or severely diseased vegetation. 	Semi-annually, at beginning of wet and dry seasons
<ul style="list-style-type: none"> Inspect and remove any sediment and debris build-up in pretreatment areas. Inspect inflow points and filter bed for build-up of sediment and debris. 	Annually, after wet season
<ul style="list-style-type: none"> Remove the top layer (approximately 3") of stone if necessary and replace with clean stone. Remove the top layer of soil/compost mix if necessary and replace with clean material. Replace stone in level spreaders if needed. The planting soils should be tested for pH to establish acidic levels. If the pH is above 7.3, then iron sulfate plus sulfur can be added to reduce the pH. 	2 to 3 years
<ul style="list-style-type: none"> Replace or rehabilitate filter bed materials if permanently clogged. Clean out underdrains if clogged with roots or debris. 	Infrequently, as needed

Box 3-2. Maintaining a Residential Rain Garden on the East End of St. Croix, USVI

A small rain garden was constructed in October 2012 as a part of a larger project done with the St. Croix Environmental Association (SEA), and funded by the NRCS Conservation Technical Assistance Program (CTAP), to help reduce erosion and sediment loading from the Hope and Carton Hill Neighborhood-- one of the restoration priorities listed in the 2011 STXEEMP Watershed Plan. The purpose of the rain garden was to serve as a driveway disconnection demonstration pilot to reduce runoff from private properties onto the eroding neighborhood roads.

Rooftop runoff in the USVI is captured in cisterns and reused, so rain gardens are not really needed to manage roof runoff. But, for this site, stormwater runoff was diverted from the ~2,100 sf driveway into a shallow rain garden with modestly-amended soils (sand & compost) to improve infiltration. A rubber speed bump was installed on the concrete driveway to direct the runoff into the rain garden via a rock-lined swale. The rain garden has a surface area of 370 sf and was sized to manage the 1-inch storm event. Any stormwater that does not infiltrate, evaporate, or get taken up by the plants will overflow back onto the driveway via a stabilized spillway.

Not only does this project help reduce road erosion, but the homeowner was able to beautify a previously unused grassy portion of her lot. After seven months, the rain garden had performed very well, and the homeowner had not seen it overflow even during large storm events. However, some important maintenance was needed. Sediment from the driveway had built up right at the edge of the driveway where the speed bump directs flow into the swale. Grass had started to grow in the sediment, creating a blockage at the most important point – the inlet!

If this were not removed, soon the stormwater would pond up at the speed bump and spill over down the driveway, bypassing the rain garden altogether. Luckily, the required maintenance just requires a shovel and some elbow grease.

Lessons Learned:

No one wants all of their hard work to be wasted by a little dirt and weeds, so be sure to plan for regular maintenance at inflow locations. This is particularly important when the runoff is from impervious cover where sediment is likely to build up (not much of a concern for most roof runoff). In addition, try to anticipate maintenance issues in your design by creating a larger drop at the inlet location.

Pre-construction site conditions



Completed Rain Garden – 7 months after construction



Arrow indicates sediment build-up at pavement/swale interface



Rain garden maintenance at inlet



Bioretention Construction Sequence

The following is a typical construction sequence. However, the actual sequence will depend on site conditions and the location of the bioretention area in relation to other areas of the site that are under construction. ***In all cases, it is important to prevent construction sediment from entering the vegetated BMP.***

Step 1. If possible, bioretention facilities should remain outside the limit of disturbance during construction to prevent soil compaction by heavy equipment.

Step 2. Construction of the bioretention practice should only begin after the entire contributing drainage area has been stabilized with vegetation. It may be necessary to block certain curb or other inlets while the bioretention area is being constructed. The proposed site should be checked for existing utilities prior to any excavation. It may be necessary to install temporary control measures (e.g., silt fence) around the perimeter of bioretention construction areas to keep sediment from side slopes and contributing drainage area out of the filter bed.

Step 3. Excavators or backhoes working adjacent to or around the perimeter of the proposed bioretention area should excavate to the appropriate design depth. Equipment tracks and wheels should stay out of the filter bed area. It is recommended to “rip” or loosen the underlying native soil (with the excavator bucket or a tiller) to promote better infiltration. Install the underdrain system if included in the design (including clean-outs and overflow structures). Cover the underdrain layer with needle-punched,



Keep heavy equipment out of the bioretention footprint during excavation and grading (top). It is also critical to wash as much of the fines off of stone as possible prior to use. Onsite rinsing of stone (bottom) helps if unwashed is only commercially-available product.

non-woven geotextile, allowing enough material to extend under the stone level spreaders adjacent to the pavement, as applicable.

Step 4. Place the approved soil/compost mix, applying in 12” inch lifts until the desired top elevation is achieved. It may be necessary to wait a few days to check for settlement, and add additional media as needed. Some may wish to saturate the bioretention with water to see if settlement occurs.

Step 5. Make sure stone is washed and cleaned to minimize dust (particularly coral stone, see **Appendix C**). Place the stone layer so that the top of the stone is even with or just below the elevation of the soil/compost layer.

Step 6. Install pretreatment measures at inlets. Make sure that there is at least a 3” drop down into the inlet from the adjacent pavement.

Step 7. Install the plant materials as per approved plans, and irrigate accordingly to ensure survival.

Step 8. Conduct final construction inspection, checking inlet, pretreatment cell or stone spreader, bioretention cell/filter bed, and outlet elevations.

Avoiding Common Pitfalls

While vegetated BMPs are not as complicated as some BMPs, there are always opportunities for something to go wrong, whether at the design, review, installation, or maintenance stage. **Table 3-5** summarizes some of the common problems that others have had and ideas on how to avoid/solve them.

Table 3-5. Tips to Avoiding Common Pitfalls

What goes wrong	How to avoid/solve it		
	Design and Review Tips	Installation Tips	Maintenance Tips
1. Inlets become clogged and runoff bypasses BMP.	Nothing is more frustrating than spending time and money building a BMP that may never get water! Design inlets with a greater elevation drop to prevent sediment from building up there and changing flow paths, particularly if you expect a lot of sediment from contributing area.	Ensure that the specified drop at the inlet is actually constructed. If a sufficient drop is not shown on the plan, consult the designer about a potential modification.	Be sure that the inlet area is inspected and maintained on a regular basis. Remove sediment blockages before they cause flooding. Once vegetation grows in the sediment it is harder to remove.
2. Overplanting the BMP	Do not design a planting plan that completely fills the BMP the day it is constructed - Design for full coverage in 2-3 years, but watch for areas of exposed soil that may become erosion problems. AVOID planting invasive species that could quickly take over.	Be sure that the plants are spaced according to the plan. Fast-growing species should be spaced farther apart than those that do not tend to spread quickly.	Don't underestimate the power of plants in the tropical climate. Plants should be trimmed/cut back when the design capacity of the BMP is reduced and/or plants clog and block the inlets and outlets, causing flooding.
3. Limestone sand is used as a soil amendment, and hardens over time	Limestone sand is basically concrete in composition, which will cause problems if used in a stormwater practice. Be sure that the plans specify coarse sand if sand is required for the design.	Inspect the sand that actually gets delivered to the site and send it back if it is not coarse sand.	If limestone sand is used for the BMP, frequent maintenance will be required to break up the hardened layer when it forms and/or the material will need to be removed/replaced.
4. Lack of ESC controls for BMPs	Be sure to specify ESC controls to protect the BMP during construction. Use erosion control matting and seeding on steep slopes, and a perimeter control such as silt fence or compost socks around the edge of the bioretention.	Do not allow runoff to flow into the BMP before upgradient areas are stabilized with vegetation. Remove any sediment buildup during construction.	If BMP constantly holds water several days after a rain event, the clogged surface layer must be removed and restored to design dimensions.

What goes wrong	How to avoid/solve it		
	Design and Review Tips	Installation Tips	Maintenance Tips
5. No signage	If people don't know what the BMP is, they might be more prone to damage them, and it is a lost education opportunity. Identify location for signage on the design plans in the most visible location for public outreach.	Ensure the sign gets installed securely as designed.	Spread the word – the more people see, the more there will be!
6. Learning from O&M and making adjustments.	Design with maintenance in mind to start with.	Install plants in the locations identified on landscaping plans – they are usually placed based on expected wetness or dryness.	Make note of which plants do well, die off quickly, and spread aggressively, gobbling up other desirable plants. For dead plants, replant first time per plan – if the same species die again, then it was ill-suited for that location. Prune back or remove overly aggressive plants.
7. Disregarding existing land use patterns	Be aware of how the locals use the land around the proposed BMP, and take that into account with design. Adjust location to avoid heavy foot traffic or recreational areas such as ball fields.	Be sensitive to surrounding land use during construction – schedule activity to avoid conflicts with neighbors and schools. Educate on-lookers about BMP.	If people are consistently walking through the BMP, consider fencing and/or more signage. If fast food trash constantly builds-up, consider a wind block.
8. People eat contaminated plants (e.g., taro, bananas) that have been growing in your BMP	Plant selection is important. Avoid using edible plants, particularly if drainage area is a parking lot or other pollution hotspot for oils and other toxins.	Follow the landscape plan, and don't substitute plants without confirming with designer.	If you see people eating plants from your BMP...remove species and replace with non-edible alternative
9. No pretreatment	For BMPs accepting road or other sediment-laden runoff, include a pretreatment measure sized for ~10% of the Pv.	Install all pretreatment practices as specified on the plans.	Remove sediment and other debris from the pretreatment measure when it is 50% full.
10. Using mulch that contains weed seed or pests	Specify the type of mulch for the project and that it must be weed and pest free. List acceptable vendors if possible.	Inspect mulch before it is placed into the BMP, and send it back if pests or seeds are observed.	When replenishing mulch, be sure to follow original spec. Pests and invasives will harm not only your BMP, but the surrounding lands as well.

Case Studies

American Samoa Environmental Protection Agency Office Building

The newly redeveloped American Samoa EPA office is one of the first LEED-certified buildings in the South Pacific. Design and construction oversight was provided by Brian Rippy and AS-EPA. LID was incorporated to reduce overall impervious cover and fulfill certification requirements, but also to test and showcase on-site stormwater practices on an island where few examples of LID exist. Funded in part by the NOAA Coral Reef Conservation Program, two bioretention cells were used to treat runoff from the parking lot. One facility manages runoff from the roof, the other manages runoff from the surrounding parking area, entrance ways, and lawn area.

Since there were no local design standards at the time, the bioretention were sized to manage runoff volume and peak discharge rate from a 2-yr 24-hr rainfall event by 25% and treat at least 80% the total suspended solids to satisfy LEED. Using NOAA Atlas 14 data, the total rainfall depth for the 2-yr storm was estimated as 7 inches. As designed, the bioretention are expected to reduce runoff volume by 51%, which is greater than the LEED requirement, plus other LID practices at the site will help to reduce runoff volume (e.g. green roof and permeable pavers).

Pretreatment practices for the bioretention include a grass channel and a concrete flume with sediment trap.



For more information on project design, construction and materials, or BMP performance, contact:

Brian Rippy, LEED AP, Principal
Resilient Design Consulting

rdcdesign.net

Office: (819) 931-3775

Wahikuli Wayside Park Rain Garden, Maui

In March 2013, the West Maui Ridge to Reef Initiative partnered with NOAA's Coral Reef Conservation Program to hold a hands-on workshop to teach homeowners and professionals alike about the benefits of rain gardens and how to construct them.

Wahikuli Wayside Park was chosen as an ideal visible location to build a rain garden where locals and visitors would see it between a popular path and prime snorkeling reefs. One of the first steps to sizing the rain garden was determining the contributing drainage area and existing flow paths. The impervious cover draining to the rain garden is shown in red (total of 3,677 sf) and includes the parking lot, half of the bathhouse roof, and the shower pad. Stormwater runoff and rinse station drainage are conveyed under the path through a PVC pipe into a thriving rain garden, where pollutants are removed, and runoff volume is reduced by infiltration and evapotranspiration.

Even though this part of the island receives little annual rainfall (<15 inches), the native plants used in the rain garden are well-suited to the conditions, and it doesn't hurt to have that extra daily shower water to keep them happy. The County of Maui Parks and Recreation Department helped with the installation and is excited about the application of rain gardens.

Lessons Learned:

Sometimes contributing drainage areas are not as clear-cut as you would expect! It is important that designers and practitioners visit the sites to fully investigate where stormwater flows. In the case of Wahikuli



Park, the contributing impervious areas are not contiguous, and it may not have been instantly apparent what was actually draining to the outfall. Just by looking at a site plan or an aerial of the location, it may have appeared that all of the impervious areas were already “disconnected,” being treated by flowing through the grassy slope before reaching the ocean. Designers and practitioners need to be stormwater detectives during site visits to make sure they see the whole picture.

For more information, contact:

Tova Callender

West Maui Watershed Coordinator

(808) 214-4239

www.westmauir2r.com

Interpretive signage installed in December 2013 at the well-established Wahikuli Rain Garden site (photo: Tova Callender).





Grass pavers installed at the new American Samoa Environmental Protection Agency office, one of the first LEED-certified buildings in the South Pacific. (photo: Brian

Chapter 4

Rethinking Parking Lots and other Hardscapes

Parking lots, roads, rooftops, and other hardscapes often consume a high percentage of a site's development envelope. These surfaces are impervious and generate surface stormwater runoff when it rains. Interestingly, runoff from roofs is generally viewed as a resource, while runoff from parking lots and other paved areas is considered a nuisance to be quickly conveyed off-site. On many islands, rooftops are frequently used to harvest valuable rainwater via cisterns for both potable and non-potable reuse. Alternatively, pavements are generally designed exclusively for transport and parking of vehicles and provision of pedestrian walkways with little consideration of hydrologic impacts. Constructed of concrete, asphalt, compacted gravel, or crushed coral, the runoff generated from these surfaces is often contaminated by oils, heavy metals, trash, and other pollutants that have collected on the pavement.

Given that these hardscapes take up significant acreages of the developed landscape and generate excessive runoff and pollutant loads, it makes sense to rethink how these areas can be more efficiently utilized to meet vehicular needs, pedestrian access, water supply, and stormwater management functions. This can be done with a series of common sense approaches to parking lot, street, driveway, and roof design that maintain function and safety while reducing that amount of runoff that must be managed by other practices.

The difference between a porous and non-porous asphalt surface can easily be seen when it is raining. Unlike impervious surfaces, permeable surfaces can accommodate vehicular and pedestrian traffic, while still allowing rainwater to infiltrate.

Seizing the Opportunity

When designing a new parking lot or building, or if retrofitting an existing developed site, consider one of the following strategies for incorporating LID:

- 1. Reduce impervious cover** and the resulting runoff through design techniques that lead to smaller parking and building footprints, more green space, and skinnier streets, while maintaining adequate and safe facilities. This happens early in the design stage, or through modification of local or jurisdictional development regulations that promote LID.
- 2. Replace standard impervious pavements** such as asphalt or concrete with permeable surfaces (e.g. pavers, porous asphalt, and porous concrete). Permeable paver applications seem to be more commonly used throughout the islands than porous asphalt or concrete, likely due to limitations of island-based processing plants.
- 3. Use vegetated BMPs** within parking lots, roadway sections, and patios, to not only reduce impervious cover, but to manage and treat runoff. Consider vegetative options for rooftops that can also provide energy savings and active use benefits.
- 4. Use cisterns and storage chambers** above or below hardscapes for reducing runoff volumes and rainwater harvesting for potable and non-potable use without sacrificing additional space on site.

- 5. Disconnect remaining impervious cover** by allowing small runoff volumes to sheet flow into existing pervious areas where it can soak into ground, be taken up by plants, or evaporate (note: this does not mean discharge to your neighbor's yard or an adjacent waterway).

Table 4-1 summarizes common LID options for better utilizing paved areas and other hardscapes. Examples of envisioning how the application of one or more of the above strategies might look in the real world is shown in **Figure 4-1**.

While all of these strategies are viable options for islands, **the majority of this chapter focuses on Strategy #2, using permeable pavements**. Given the likely challenge of island manufacturers batch-producing separate mixes for porous concrete or asphalt, most of the subsequent discussion relates to the use of permeable pavers.



Islands have an inherent interest in rainwater harvesting to reduce the burden on drinking water supplies. Cisterns are commonly used for small-scale potable water or to satisfy non-potable needs (e.g., irrigation, toilet flushing, car washing, fire suppression).

Table 4-1. Common Hardscape LID Options

LID Strategy	Applications	Island Example
<p>1. Reduce Impervious Cover</p>	<ul style="list-style-type: none"> • Applicable at site design stage, since the less impervious cover created, the less stormwater runoff volume generated. Can be done without reducing development yield. • Reduce parking footprints and road widths/length • May need to work with local or federal agencies to provide flexibility in design requirements. 	
<p>2. Use Permeable Pavement - replacing asphalt or concrete with various permeable alternatives</p>	<ul style="list-style-type: none"> • Particularly good for overflow parking, parking stalls, parking lanes, driveways, and patios/hardscapes. • Can include permeable asphalt, concrete, grid pavers, or interlocking concrete pavers. • Depending on storage capacity of underlying stone layer, can be designed for runoff reduction (infiltration), water quality treatment, and/or larger storm detention. 	
<p>3. Use vegetated BMPs in associated rights-of-way, medians, in parking lots, or on roofs to capture and treat runoff.</p>	<ul style="list-style-type: none"> • Convert existing landscapes and turf areas into bioretention or other BMP (see Chapter 3). • Can be good practices for overly-wide roads; can double as traffic-calming measures; can be integrated with street tree programs. Trees can take up a lot of water and provide shade. • Improve aesthetics while handling localized flooding problems. • Green roof may compete with cisterns, solar. 	
<p>4. Use cisterns or storage chambers below buildings, driveways or parking lots for recharge or rainwater reuse/harvesting</p>	<ul style="list-style-type: none"> • Can be designed for infiltration or storage & release or reuse (non-potable). • Source of runoff can be parking/hardscapes and/or adjacent rooftops. • Requires pretreatment if coming from a high use parking lot or roadway where PAHs, oils or other contaminants have a high likelihood of contaminating groundwater. • Be sure not to block access manholes. 	
<p>5. Disconnect remaining impervious cover</p>	<ul style="list-style-type: none"> • Design site so small areas of impervious are “disconnected” and can drain to pervious areas • Must understand capacity of pervious areas to handle frequent flows. • Do not direct flows off-site without proper management 	

Figure 4-1. Incorporating LID into Hardscapes



This retailer on Guam uses a ponding basin for temporary detention of parking lot runoff.

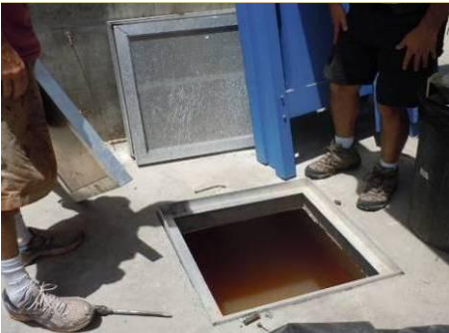
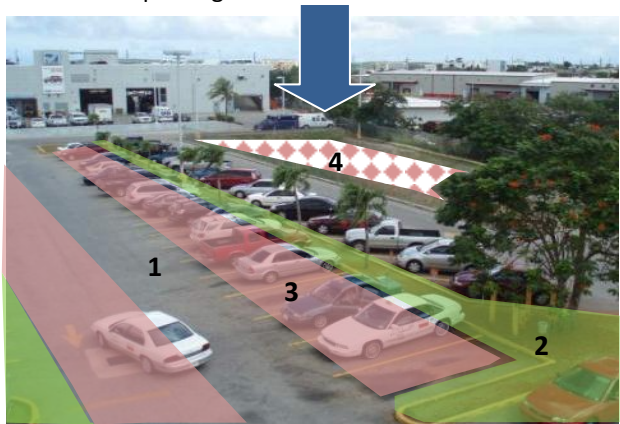

Seize the opportunity to apply LID, add more shade, and increase number of parking spaces:

1. Reduce impervious cover by using angle-in parking, reduce aisle widths using one-way circulation patterns, and reducing stall dimensions.
2. Create below-grade parking islands to serve as infiltrating bioretention/bioswales (see Chapter 3).
3. Replace parking stalls with permeable surfaces
4. Replace area used by ponding basin for more parking spaces. Install underground storage tanks below parking to capture roof runoff for non-potable reuse.



A typical Puerto Rico road right-of-way (ROW) includes travel/parking lanes, utilities, street trees, and sidewalks.

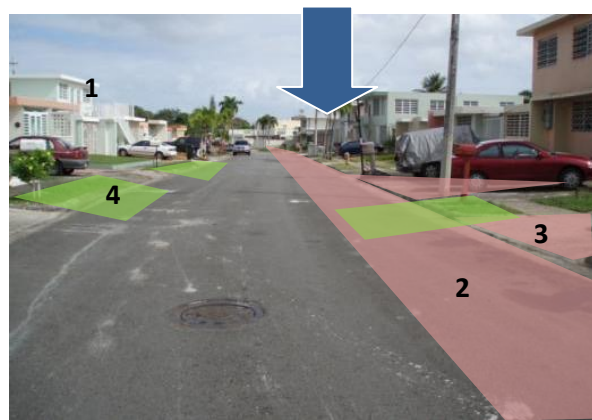

Seize the opportunity to apply LID, beautify neighborhood roads, reduce runoff from homes, and slow traffic down.

1. Make sure all homes have a cistern to collect rooftop runoff.
2. Reduce road width or add permeable parking lane(s).
3. Use permeable materials for driveways.
4. Add green street features such as bioretention bumpouts or tree pit filters to capture road runoff at curb inlets and slow traffic. parking lanes, utilities, street trees, and sidewalks.



Recent aerial photo showing the extent of roof coverage of downtown Honolulu.



The University of Hawaii at Manoa (Kaufman et al., 2007) simulated what 75% green roof coverage might look like. Consider the:

- Energy savings associated with reduced cooling costs;
- Access to new useable green space for office workers and residents of apartment complexes;
- Reduced volume of runoff associated with plant uptake and evaporation.

A Word on Rainwater Harvesting and Using Rooftops

Rooftops provide a great opportunity for reducing the volume of stormwater runoff, and relieving pressure on the potable water supply. This can be particularly relevant for islands relying on groundwater aquifers for drinking water, where both recharge and reducing demand may be important objectives. Cisterns and green roofs are two examples of LID practices to consider.

Islanders have as much, if not more, experience as the mainland US when it comes to rainwater harvesting (i.e., the interception diversion, and storage of rainfall for future use). In fact, the US Virgin Islands is one of the few jurisdictions that require new residential and commercial buildings to install cisterns where public water or wells are not available. Roofs are ideal for the collection and storage of rainwater for reuse since runoff can be easily captured and is relatively free of sediments and other contaminants (although, traditional galvanized metal roofing and pressure-treated/waterproofed wood have been shown to leach metals and other chemicals of concern).

Where locally-approved, cisterns can be used to harvest rain for drinking water (requires appropriate treatment systems to treat water to potable standards) and for non-potable reuse (e.g., flushing toilets, landscape irrigation, wash water, dust control, fire suppression, water fountains, and pool replenishment). Storage and reuse of driveway and parking lot runoff for landscape irrigation is also becoming a more popular practice. Rainwater harvesting systems:

- Can be installed above or below ground;
- Are flexible in design, where design volumes and flows are dependent on the size of the tank or cistern selected as well as the year-round demand for reuse of the water;
- Can include flow control technologies to all for manual or automated drawdown prior to storm events;
- Are adaptable to the wet season and dry season conditions by adding a “soakaway” valve to help drain the tank based on indoor and outdoor usage adjustments; and
- Can be combined with down-gradient BMPs (e.g., infiltration trench, rain garden).

Less commonly seen in the islands are green roof systems. Green roofs utilize a combination of vegetation and soils to reduce runoff volumes from small storm events through increased evapo-transpiration and filtration. Green roofs provide other benefits ranging from improved energy efficiency of buildings via insulation and cooling effects, to increased aesthetics and community open space.

A few recommended guidance documents (available on-line) for islanders that address cistern sizing, design, and maintenance include:

- 2010 Guidelines on Rainwater Catchment Systems for Hawai‘i
- 2008 Stormwater Reclamation and Reuse Best Management Practices in Hawaii
- 2001 Designing Your Rainwater Catchment and Storage System and/or Construction of a Water Storage Tank for Micronesia
- 2010 Island Stormwater Practice Design Specifications, a supplement to the CNMI and Guam Stormwater Manual
- 2011 Cistern Water Quality Testing & Results in Coral Bay, St. John, US Virgin Islands

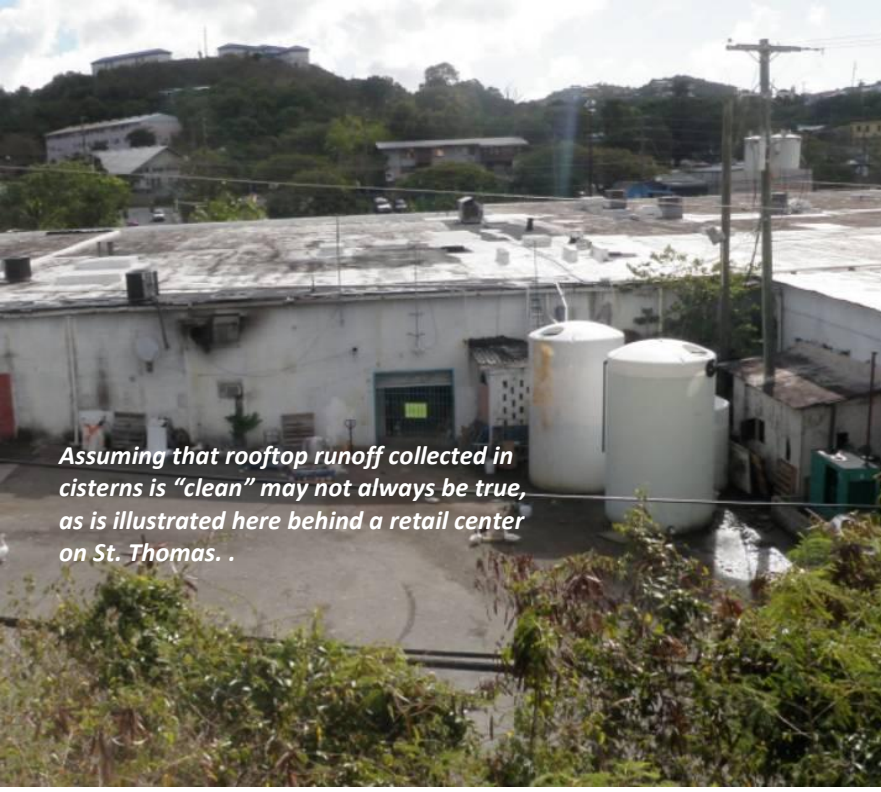

Assuming that rooftop runoff collected in cisterns is "clean" may not always be true, as is illustrated here behind a retail center on St. Thomas. .

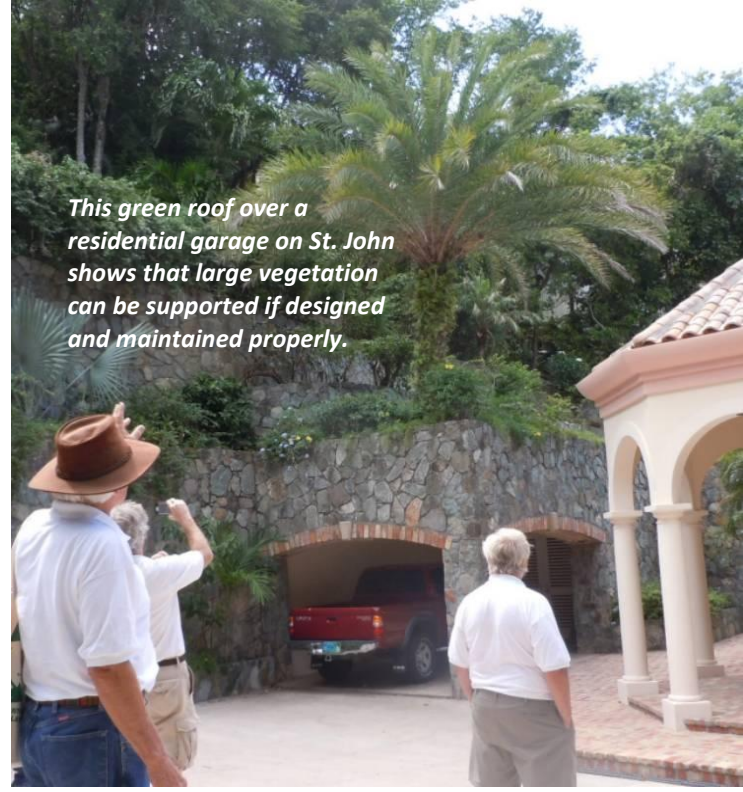

This green roof over a residential garage on St. John shows that large vegetation can be supported if designed and maintained properly.

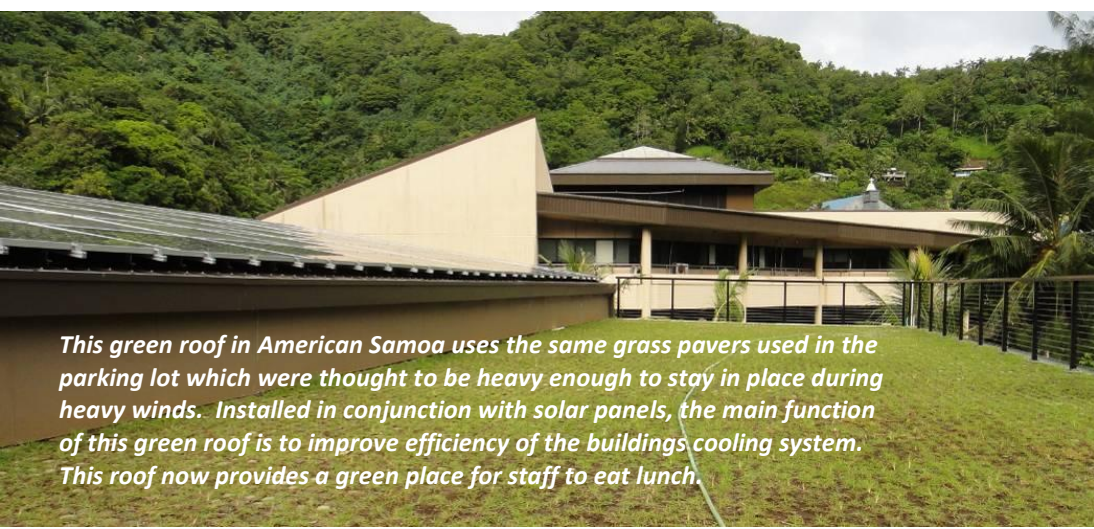

This green roof in American Samoa uses the same grass pavers used in the parking lot which were thought to be heavy enough to stay in place during heavy winds. Installed in conjunction with solar panels, the main function of this green roof is to improve efficiency of the buildings cooling system. This roof now provides a green place for staff to eat lunch.

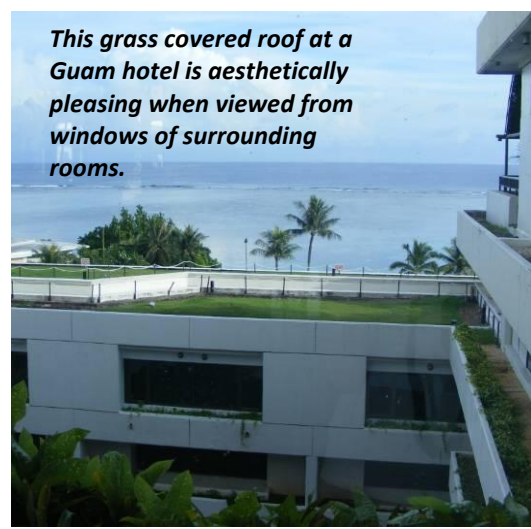

This grass covered roof at a Guam hotel is aesthetically pleasing when viewed from windows of surrounding rooms.



This residence on Saipan illustrates the basic concept that freshwater from the sky is a valuable resource. The cistern is being used to collect water for reuse inside the home. The containers and plants over the shed is a clever expression of green roof techniques applied in the mainland US.

Using Permeable Surfaces

Permeable parking and walkways are good alternatives to conventionally-paved impervious surfaces. Permeable surfaces allow stormwater to filter through voids in the pavement surface into an underlying stone layer, where it is temporarily stored and/or infiltrated. This specification focuses on the use of permeable interlocking concrete pavers (PICP) and concrete grid pavers (CGP). However, a variety of other permeable pavement surfaces are available; including pervious concrete, porous asphalt, and plastic grid pavers (**Table 4-2**).

While the specific design may vary, all permeable pavements have a similar structure consisting of a surface pavement layer, a bedding layer, an underlying stone layer, a filter layer, and often a geotextile installed on the bottom.

The thickness of the underlying stone layer is determined by both a structural and hydrologic design analysis. This layer serves to retain stormwater and also supports the design traffic loads for the pavement. There are two basic design adaptations for Permeable Parking and Walkways:

1. Infiltration Design/no underdrain

(**Figures 4-2 and 4-3**): If infiltration rates of the on-site soils allow, permeable pavement can be designed *without* an underdrain to enable full infiltration of runoff. Soil testing should be performed at the site to ensure suitable infiltration rates, deeper depths to groundwater, and a low risk of groundwater contamination (e.g., not located at a stormwater hotspot).

2. Filter Design with underdrain

(**Figures 4-4 and 4-5**): For sites where on-site soils do not percolate as readily, some or all of the filtered runoff can be collected in an underdrain and returned to the storm drain system. The use of underdrains is recommended when there is a reasonable potential for infiltration rates to decrease over time, when underlying soils have an infiltration rate of less than 1/2-inch per hour, or when soils must be compacted to achieve a desired Proctor density (see structural design discussion in Box 4-1). These designs still incorporate some level of infiltration, especially during the dry season, by providing a stone “infiltration sump” and filter layer below the underdrain pipe.

Table 4-3 provides details and notes for each of the permeable parking design components shown in the typical details. Note that **Figures 4-2** through **4-5** call for the use of coral stone under the assumption that this material may be all that is readily available on some islands. Volcanic-based rock or appropriately sized gravel (approximately 1-inch) is in fact preferable where these materials are available.



Beveled spacers along the edges of paver blocks create the gaps between each interlocking concrete paver where water can infiltrate.



Interlocking brick pavers used for parking stalls at Popo'ia retrofit on Oahu.



Interlocking brick pavers used for entire parking lot at Mormon Church on Tutuila, American Samoa.



Concrete block pavers used in a sandy Lao Lao Bay parking lot on Saipan.



Concrete grid pavers used at multi-family housing complex on St. John, USVI.

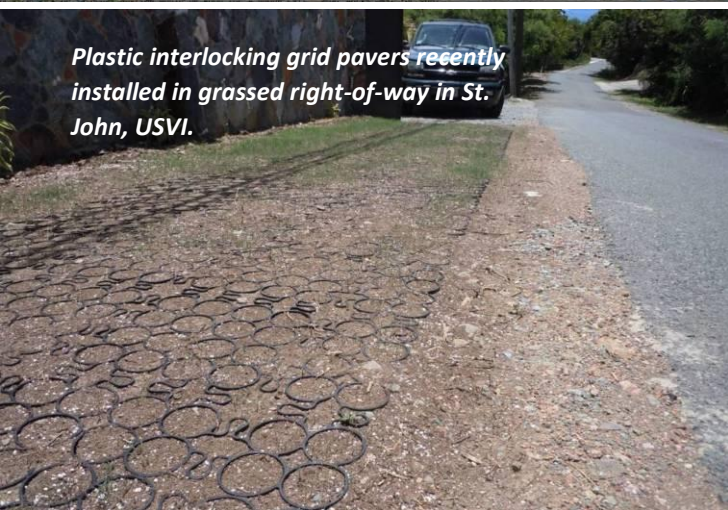

Plastic interlocking grid pavers recently installed in grassed right-of-way in St. John, USVI.











No fancy pavers here, just grass to "disconnect" runoff from off-street parking in Garapan, CNMI.



Grass pavers used for drive aisle and parking stalls in American Samoa.

Table 4-2. Typical Pervious Pavement Materials

Type	Material	Application
Pervious Concrete		 <p>Mainland</p>
Porous Asphalt		 <p>Buzzards Bay, MA</p>
Concrete Grid Pavers (CGP)		 <p>Saipan, CNMI</p>
		 <p>Puerto Rico</p>

Type	Material	Application
<p>Permeable Interlocking Concrete Pavers (PICP)</p>		 <p>St. Croix, USVI</p>
		 <p>Oahu, HI</p>
<p>Plastic Grid Pavers</p>		 <p>St. Thomas, USVI</p>
		 <p>St. John, USVI</p>

Figure 4-2. Cross-sections for Permeable Interlocking Concrete Paver (PICP) infiltration design version (no underdrain).

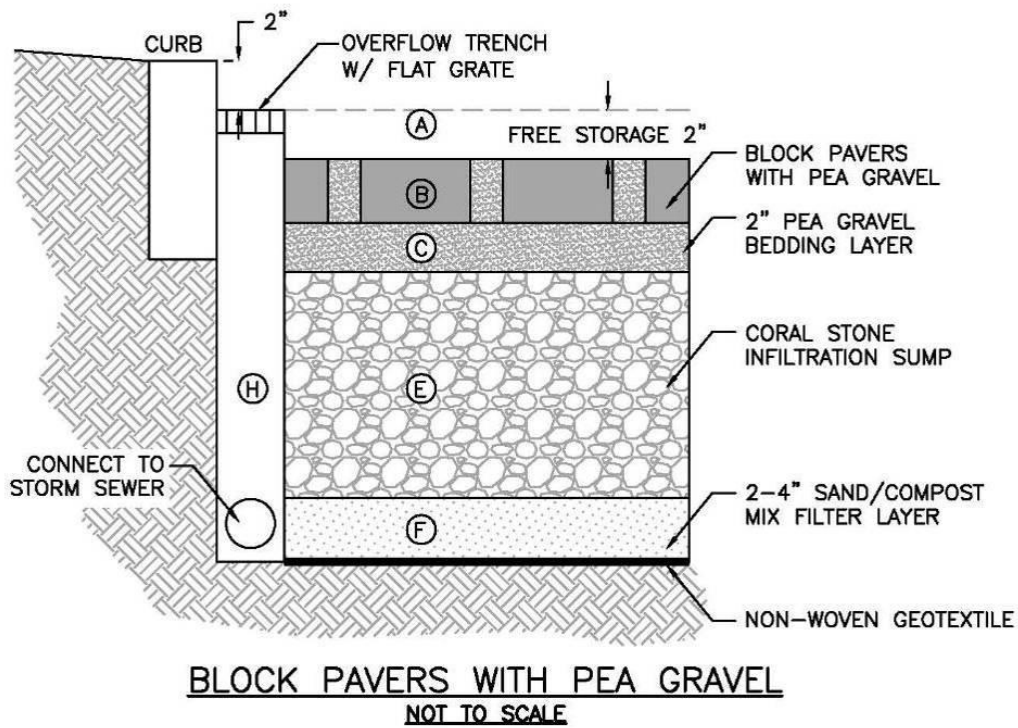

Figure 4-3. Cross-sections for Concrete Grid Paver (CGP) infiltration design version (no underdrain).

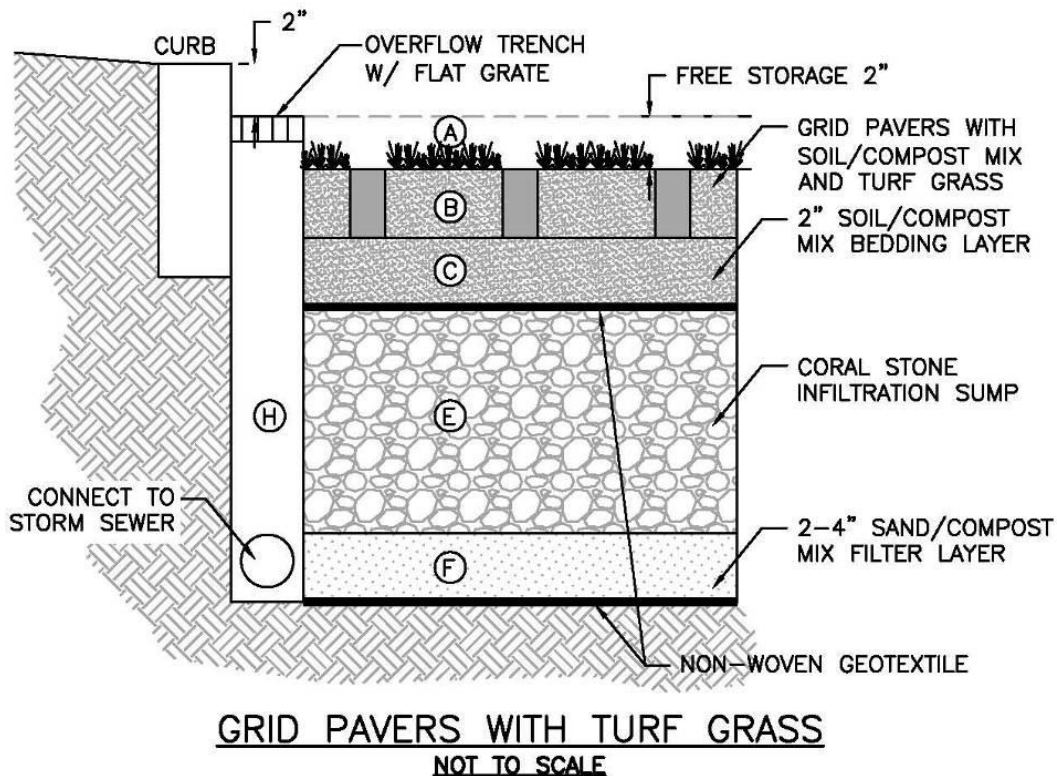
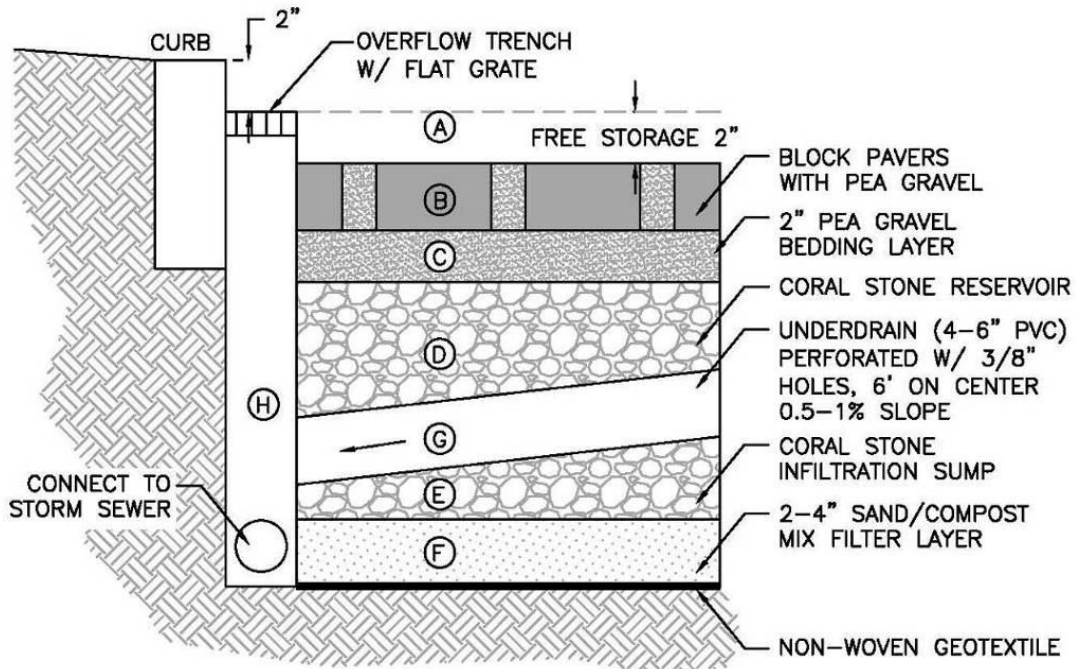
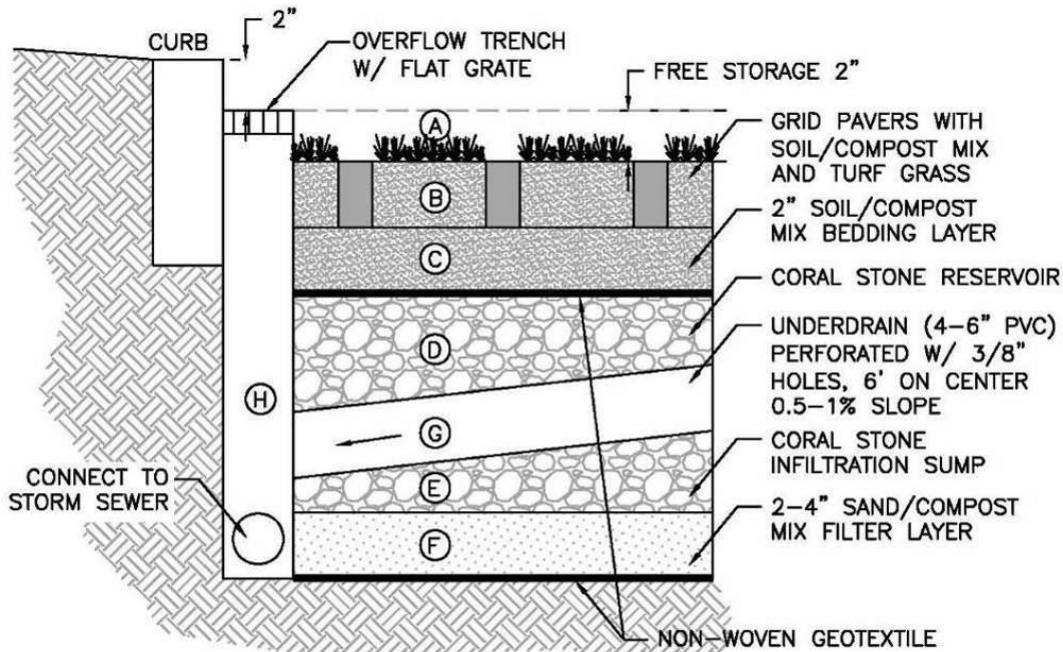

Figure 4-4. Cross section of PICP filter design version (includes underdrain).



BLOCK PAVERS WITH PEA GRAVEL AND UNDERDRAIN
 NOT TO SCALE

Figure 4-5. Cross section of CGP filter design version (includes underdrain).



GRID PAVERS WITH TURF GRASS AND UNDERDRAIN
 NOT TO SCALE

Table 4-3. Description of Permeable Parking and Walkway Design Components

Material	Specification	Notes
Free Storage (A*)	<ul style="list-style-type: none"> Up to 2" above pavement surface 	Control ponding level with overflow structure, or by-pass higher flows to drop inlet in parking lot.
Pavement Surface (B)	PICP (as provided below or follow manufacturer's recommendations): <ul style="list-style-type: none"> Surface open area: 5% to 15%. Thickness: 3 1/8 inches for vehicles. Compressive strength: 8,000 psi. Open void fill media: pea gravel 	Should conform to ASTM C936 specifications.
	CGP (as provided below or follow manufacturer's recommendations): <ul style="list-style-type: none"> Open void content: 20% to 50%. Thickness: 3.5 inches. Compressive strength: 5,100 psi Open void fill media: pea gravel, topsoil and grass, or coarse sand. 	Should conform to ASTM C 1319 specifications.
Bedding Layer (C)	PICP: 2 " depth of pea gravel	
	CGP: 2" soil/compost mix	Follow guidance in Soil Compost Media specification in Appendix C . Other compost media or sand mixtures may be substituted if tested and approved. Phosphorus loading from compost could be an issue.
Gravel or Coral Stone Infiltration Sump Layer (E)	<ul style="list-style-type: none"> Clean, washed gravel or coral stone; minimize amount of "dust" (very fine particles) For gravel (preferred), diameter should be approximately 1" Bottom of this layer should be flat Place on sand/compost filter layer 	<p>For infiltration designs (without underdrains), this layer should be sized for both the storm event to be treated and the structural requirements of the expected traffic loading.</p> <p>For filter designs (with underdrains), the additive stone infiltration sump layer (E) and underdrain stone reservoir (D) should be sized for both the storm event to be treated and the structural requirements of the expected traffic loading.</p> <p>If using coral stone, all flow that passes through the stone should also pass through soil/compost mix to lower pH and reduce chance of heavy metal leaching.</p>
Underdrains & Cleanouts (only for underdrain designs) (G)	<ul style="list-style-type: none"> 4 – 6" inch rigid schedule 40 PVC pipe (or equivalent corrugated HDPE for small applications) 3/8" perforations at 6" on center Perforations only below filter bed Minimum slope = 0.5%; 1% recommended Position underdrain pipes ≤ 20' apart Clean-outs non-perforated & tied to underdrain with elbow; all clean-outs capped at surface 	Lay the perforated pipe under the length of the pavement cell, and install non-perforated pipe as needed to connect with the storm drain system. Install T's and Y's as needed, depending on the underdrain configuration. Extend cleanout pipes to the surface with vented caps.

Material	Specification	Notes
Underdrain Gravel or Coral Stone Reservoir Layer (only for underdrain designs) (D)	<ul style="list-style-type: none"> • Clean, washed gravel or coral stone; minimize amount of “dust” (very fine particles) • Place underdrain pipe in top 8” of underdrain stone • Provide ≥ 8” of stone below underdrain pipe to serve as dry season infiltration sump 	The additive stone infiltration sump layer (E) and underdrain coral stone layer (D) should be sized for both the storm event to be treated and the structural requirements of the expected traffic loading.
Sand/Compost Filter Layer (F)	<ul style="list-style-type: none"> • Where possible, silica-based sand should be used for the filter layer. If sand materials are limited, a sand/compost layer can be used. Follow guidance in Soil Compost Media specification in Appendix C. • Place underneath coral stone layer so that all flow passes through this layer. 	Other compost media or sand mixtures may be substituted if tested and approved by the plan-approving authority.
Geotextile	<ul style="list-style-type: none"> • Needle-punched, non-woven geotextile fabric with a flow rate > 110 gal./min./sq. ft. (e.g., Geotex 351 or equivalent) • Place as shown on typical details in Figures 4-2 through 4-5 	More impermeable liners may be needed at facility invert for hotspot land uses or in close proximity to drinking water sources; do NOT place impermeable liners between soil/compost and underdrain stone.
Impermeable Liner	NOTE: THIS IS ONLY RECOMMENDED FOR DESIGNS IN CLOSE PROXIMITY TO WATER SUPPLY SOURCES, FILL SLOPES, and OTHER HOTSPOT AREAS. Using this layer effectively eliminates the potential to provide any infiltration. Use a thirty mil (minimum) PVC Geomembrane liner covered by 8 to 12 oz./sq. yd. non-woven geotextile.	
Overflow Structure (H)	<ul style="list-style-type: none"> • Sized for 10-year storm peak intensity and discharge or expected wet season flow • Structure scaled to application (e.g., yard inlet, commercial structure) 	
Observation Well	Use a perforated 4- to 6-inch vertical PVC pipe (AASHTO M 252) with a lockable cap, installed flush with the surface.	The observation well is used to observe the rate of drawdown within the coral stone layer following a storm event and to facilitate periodic inspection and maintenance.

* Letters correspond to labels in **Figures 4-2 through 4-5**.

Sizing Permeable Pavement Systems

The system should be sized to meet overall management objectives. See **Chapter 2** for a suggested methodology for identifying performance standards and management objectives, and for translating these into a target volume for the BMP. Based on the

terminology of **Practice Volume (P_v)** used in **Chapter 2, Box 4-1** outlines the storage volume provided by each layer of the practice (for infiltration and underdrain design, respectively). The letters in **Box 4-1** refer to the typical details in **Figures 4-2** through **4-5**.

Box 4-1. Sizing the Permeable Pavement System to Meet Treatment Objectives

Important Notes:

- Sizing Equations Reference the Typical Details in **Figures 4-2 through 4-5**.
- For permeable pavement systems that must support vehicles and structural loads, the structural design will likely dictate the pavement surface and underlying layers. See the guidance below for more details.
- As noted earlier, **Figures 4-2 through 4-5** reference use of coral stone. This was done under the assumption that some jurisdictions would have trouble obtaining other types of stone (e.g., gravel derived from non-coral sources). However, if other types of gravel are available, this should be used in lieu of coral stone.

The **Practice Volume (P_v)** is the storage provided by the practice to meet water quality or runoff reduction goals. See Chapter 2 for the overall methodology for determining the P_v .

Infiltration Designs (no underdrains):

$$P_v = V_A + V_B + V_C + V_E + V_F$$

Where:

P_v = Total Practice Volume (cubic feet)

V_A = Storage volume of free storage = free storage volume (A) x 1.0

V_B = Storage volume of surface storage layer = surface layer volume (B) X surface open void space;
(PICP open void space = 0.1, CGP open void space = 0.4)

V_C = Storage volume of pea gravel OR soil/compost bedding layer = pea gravel OR soil/compost bedding volume x bedding layer void space (pea gravel = 0.4, soil/compost = 0.25)

V_D = Storage volume of gravel or coral stone reservoir layer (above underdrain) = gravel or coral stone underdrain layer volume (D) x 0.18 (NOTE: This layer only receives 45% of the volume provided, since much of the water exits the underdrain; therefore, the equation is: volume x 0.4 (void ratio of stone) x 0.45, or volume x 0.18)

V_E = Storage volume of gravel or coral stone infiltration sump layer (below underdrain for filter design) = volume of coral stone layer (E) x 0.40

V_F = Storage volume of sand/compost filter layer = volume of sand/compost filter (F) x 0.25

V_G = Underdrain, sized for expected wet season flows

V_H = Overflow, sized for wet season, such that peak flow managed by (G) + (H)

Filter Designs (with underdrains):

$$P_v = V_A + V_B + V_C + V_D + V_E + V_F$$

Structural Design. If permeable pavement will be used in a parking lot or other setting that involves vehicles, the pavement surface must be able to support the maximum anticipated traffic load. The structural design process will vary according to the type of pavement selected, and the manufacturer's specific recommendations should be consulted. The thickness of the permeable pavement and gravel/coral stone layer must be sized to support structural loads and to temporarily store the Practice Volume. On most new development and redevelopment sites, the structural support requirements will dictate the depth of the underlying coral stone layer. The structural design of permeable pavements involves consideration of four main site elements: 1) Total traffic; 2) In-situ soil strength; 3) Environmental elements; and 4) Bedding and gravel/coral stone layer design. The resulting structural requirements may include, but are not limited to pavement, filter, and coral stone layer thickness. Designers should note that if the underlying soils have a low California Bearing Ratio (CBR) (less than 4%), they may need to be compacted to at least 95% of the Standard Proctor Density, which generally rules out infiltration designs. **Designers should consult a structural or roadway design engineer to determine the structural design requirements for all permeable pavement systems that are expected to receive vehicle traffic and loading.**

Unique Island Factors

Given that permeable pavement materials are generally available from vendors, the main considerations for island environments would be the cost of securing the materials and how to structure the underground section below the surface pavers. On some islands, sand and gravel may not be available at a reasonable cost, so the specification uses island substitutions, such as coral stone. In addition:

- Batch plants may not make alternative mixtures for porous concrete or asphalt;
- Equipment needed for maintenance, such as vactor trucks, may have limited availability;
- Concrete pavers could be made on island if proper molds are available;
- Plastic gird pavers are lighter weight, but may not be durable to tropical sun exposure; and
- Use of crushed coral stone can lead to clogging due to cementing of fines.

Key Design Considerations

The following considerations and design guidance are important when planning and implementing permeable parking and walkway systems.

Available Space. A prime advantage of permeable pavement is that it does not normally require additional space at a new development or redevelopment site, which can be important for tight sites or areas where land prices are high.

Soils. Soil conditions do not constrain the use of permeable pavement, although they do determine whether an underdrain is needed. Less permeable soils in Hydrologic Soil Groups (HSG) C or D usually require an

underdrain, whereas HSG A and B soils often do not. In addition, permeable pavement should never be situated above fill soils unless designed with an impermeable liner and underdrain. When designing permeable pavement, designers should verify soil permeability by using the methods outlined in **Appendix D**.

Adjacent Vegetation. Location of permeable pavements near big trees can be an issue if excessive foliage dropping onto surfaces is crushed by tires into pavement void spaces. Keep vegetative maintenance in mind during the design phase.

External Drainage Area. Any external drainage area contributing runoff to permeable pavement should generally not exceed twice the surface area of the permeable pavement, and it should be as close to 100% impervious as possible. Some field experience has shown that an up-gradient drainage area (even if it is impervious) can contribute particulates to the permeable pavement and lead to clogging. Therefore, careful sediment source control and/or a pre-treatment strip or sump (e.g., stone or gravel) should be used to control sediment run-on to the permeable pavement section.

Ideally, permeable pavements should be designed to manage the stormwater that falls directly onto them. Off-site run-on should be limited and adequate pretreatment must be provided.

Pavement Slope. Steep slopes can reduce the stormwater storage capability of permeable pavement and may cause shifting of the pavement surface and base materials. Typically, the pavement surface slope should be less than 1.0%. The bottom

slope of a permeable pavement installation should be as flat as possible (i.e., 0% lateral slope) to enable even distribution and infiltration of stormwater. For applications on moderate slopes (e.g., up to 5%), designers should consider a terraced or cell design, either along the bottom grade (where the bottom layer meets the underlying soil), at the surface, or both. The objective is to maintain flat conditions where the bottom layer meets the underlying soil.

Minimum Hydraulic Head. The elevation difference needed for permeable pavement to function properly is generally nominal, although 2 to 4 ft. of head may be needed to drive flows through underdrains. Flat terrain may affect proper drainage, so underdrains should slope a minimum 0.5%.

Water Table and Bedrock. Permeable pavement should always be separated from the water table and bedrock to ensure that groundwater does not intersect the underlying stone or filter layers. Mixing can lead to possible groundwater contamination or failure of the permeable pavement facility. A separation distance of 2 feet is recommended between the bottom of the excavated permeable pavement area (i.e., the bottom invert of the filter layer) and the seasonally high ground water table or bedrock layer.

Setbacks. In order to avoid harmful seepage, permeable pavement should not be hydraulically connected to structure foundations. At a minimum, permeable parking and walkways should be located a minimum horizontal distance of 100 feet from any water supply well, 50 feet from septic systems, and at least 5 feet down-gradient from dry or wet utility lines such as

gas, electric, cable and telephone (unless these are double-cased).

Informed Owner. The property owner should clearly understand the unique maintenance responsibilities inherent with permeable pavement, particularly for parking lot applications. The owner should be capable of performing routine and long-term actions (e.g., vacuum sweeping) to maintain the pavement's hydrologic functions, and avoid future practices (e.g., seal coating or repaving) that diminish or eliminate them.

High Loading Hotspot Land Uses. Permeable pavement is not intended to treat sites with high sediment or trash/debris loads, since such loads will cause the practice to clog and fail. Further, runoff from hotspot land uses should not be managed directly with permeable parking or walkways. For a list of potential stormwater hotspots, please consult Section 2.1.1.1 of the *CNMI & Guam Stormwater Management Manual, Vol.1*.

Do not use permeable pavements at pollution hotspots unless they are lined to prevent infiltration of contaminants into groundwater or include adequate pretreatment.

Pretreatment. Pretreatment for most permeable pavement applications is not necessary, since the surface acts as pretreatment to the stone layer below. Additional pretreatment may be appropriate if the pavement receives runoff from an adjacent pervious or impervious area. For example, a gravel filter strip can be used to trap coarse sediment particles before they reach the permeable pavement surface, in order to prevent premature clogging.

Conveyance for Larger Storms. Permeable parking and walkway designs should include methods to convey larger storms (e.g., 2-yr, 10-yr) to the storm drain system. The following is a list of methods that can be used to accomplish this:

- Set the storm drain inlets up to 2" above the elevation of the permeable pavement surface (if inlets are not in the traffic flow path) to effectively convey excess stormwater runoff past the system.
- Route excess flows to another detention or conveyance system that is designed for the management of extreme event flows.
- Create underground detention within the stone layer of the permeable pavement system. Storage may be augmented by corrugated metal pipes, plastic or concrete arch structures, or similar structures.
- Increase the thickness of the top of the stone layer by as much as 6 inches (i.e., create freeboard). The design computations used to size the stone layer assume that no freeboard is present. As this will make the system deeper, make sure to maintain adequate separations to water table and bedrock (see above).
- Place a perforated pipe horizontally near the top of the stone layer to pass excess flows after water has filled the base. The placement and/or design should be such that the incoming runoff is not captured (e.g., placing the perforations on the underside only).
- In infiltration designs, underdrains can also be used to manage extreme storm events to keep detained stormwater

from backing up into the permeable pavement.

Soil/Compost or Sand Media. It will be necessary to find a suitable soil/compost or sand mix for the permeable pavement filter layer. This mix will likely come from a topsoil or sand vendor or other local source. Guidelines for creating and testing the soil/compost mix are detailed in **Appendix C**.

Infiltration Rate Testing for Infiltration Designs. For designs that do NOT include an underdrain, it will be necessary to conduct infiltration testing to determine infiltration suitability. If underlying soils are not suitable for infiltration, the underdrain design should be used. Guidelines for conducting the permeability test (field test to determine hydraulic conductivity) are included in **Appendix D**.

Erosion & Sediment Control During Construction & Initial Installation. The construction and installation phase is the most critical for the long-term success of permeable pavement systems. The following general guidelines should be adhered to during construction:



- All permeable pavement areas should be fully protected from sediment intrusion by silt fence or other sediment barriers, particularly if they are intended to infiltrate runoff.
- Permeable pavement areas should be clearly marked on all construction documents and grading plans. To prevent soil compaction, heavy vehicular traffic should be kept out of permeable pavement areas during and immediately after construction. This is particularly true for infiltration designs.
- During construction, care should be taken to avoid tracking sediments onto any permeable pavement surface to avoid clogging.
- Any area of the site intended ultimately to be a permeable pavement area should generally not be used as the site of a temporary sediment basin.

Maintenance. Maintenance is a crucial element to ensure the long-term performance of permeable pavement. The most frequently cited maintenance problem is surface clogging caused by organic matter and sediment. Aside from regular mowing of CGP turf grass applications, it is difficult

to prescribe the specific types or frequency of maintenance tasks needed to maintain the hydrologic function of permeable pavement systems over time. Most installations work reasonably well year after year with little or no maintenance, whereas some have maintenance needs early in the life of the system.

One preventative maintenance task for permeable parking applications involves vacuum sweeping on a frequency consistent with the use and loadings encountered in the parking lot. Many consider at least an annual, dry-season sweeping to be important, and more frequent sweeping is likely needed if the contributing areas have relatively high sediment loads or are landscaped. The contract for sweeping should specify that a sweeper be used that does not use water spray, since spraying may lead to subsurface clogging. Any surface void material that is picked up or displaced during sweeping should be replaced with clean material. **Table 4-4** provides suggested annual maintenance inspection points to evaluate the condition and performance of the practice and remedial actions.

Table 4-4. Maintenance Inspection Guidelines for Permeable Pavement Systems

Inspection Activity	Remedial Action
Mow grass paver periodically to prevent overgrowth of vegetation (CGP, turf pavers)	Remove vegetation if blocking flow
Inspect surface for signs of surface clogging.	Vacuum sweep (no brooms or water spray) to remove deposited fines. For interlocking concrete pavement designs, it may be necessary to replace some of the pea gravel or sand between the blocks after vacuum sweeping.
Inspect the structural integrity of the pavement.	Replace or repair affected areas, as necessary.
Check inlets, pretreatment and flow diversion for sediment buildup and structural damage.	Remove sediment or repair affected areas.
Inspect contributing drainage area (CDA) for any sources of sediment or erosion.	Stabilize CDA or install sediment barriers to prevent run-on.
Measure drawdown rate in observation well after storms > 0.5 in.	Standing water after 3 days = clogging problem. Replace or repair affected areas.

Permeable Pavement Construction Sequence

The following is a typical construction sequence to properly install PICP and CGP for parking or walkways. This sequence may need to be modified if other types of permeable pavement (i.e., porous asphalt/pervious concrete) designs are employed.

Step 1. Construction of the permeable pavement shall only begin after the entire contributing drainage area has been stabilized. The proposed site should be checked for existing utilities prior to any excavation. Do not install the system during rainfall.

Step 2. As noted above, temporary erosion and sediment (E&S) controls are needed during installation to divert stormwater away from the permeable pavement area until it is completed. Special protection measures such as erosion control fabrics may be needed to protect vulnerable side slopes from erosion during the excavation process. The proposed permeable pavement area must be protected from sediment during the entire construction process. Construction materials (e.g., stone, gravel, sand) that are contaminated by sediments must be removed and replaced with clean materials.

Step 3. Where possible, excavators should work outside the permeable pavement footprint area to excavate the underlying layers to their appropriate design depth and dimensions. This action will help to avoid compaction of underlying soils. Contractors can utilize a cell construction approach, whereby the proposed permeable pavement area is split into 500 to 1,000 sq.

ft. temporary cells with a 10 to 15-foot earth bridge in between, so that cells can be excavated from the side. Excavated material should be placed away from the open excavation so as to not jeopardize the stability of the side walls.

Step 4. Any native soils along the bottom and sides of the permeable pavement system should be scarified or tilled to a depth of 3 to 4 inches prior to the placement of the geotextile and filter layer. In large scale parking applications with weak underlying soils, the soil subgrade may need to be compacted to 95% of the Standard Proctor Density to achieve the desired load-bearing capacity. (NOTE: This effectively eliminates the infiltration function of the installation, and it must be addressed during hydrologic design.)

Step 5. Geotextile should be installed on the bottom of the filter layer. The filter layer (2-4 inches of sand/compost mix) should be placed on top of the geotextile.

Step 6. Provide a minimum of 2 inches of gravel or stone below the underdrains. The underdrains should slope down towards the outlet at a grade of 0.5% or steeper. The up-gradient end of underdrains in the stone layer should be capped. Where an underdrain pipe is connected to a structure, there shall be no perforations within 1 foot of the structure. Ensure that there are no perforations in clean-outs and observation wells within 1 foot of the surface.

Step 7. Moisten and spread 6-inch lifts of the clean, washed stone. Place at least 4 inches of additional stone above the underdrain pipe, and then compact it with at least four (4) passes of a 10-ton steel drum static roller until there is no visible

movement. The first two (2) passes are in vibratory mode, with the final two (2) passes in static mode. Do not crush the stone with the roller.

Step 8. Place edge restraints for open-jointed pavement blocks before the bedding layer and pavement blocks are installed. PICP and CGP systems require edge restraints to prevent vehicle loads from moving the paver blocks. Edge restraints may be standard curbs or gutter pans, or precast or cast-in-place reinforced concrete borders a minimum of 6 inches wide and 18 inches deep, constructed with Class A3 concrete. Edge restraints along the traffic side of a permeable pavement block system are recommended. Install the bedding layer depending on the type of pavement:

- PICP: The bedding layer for open-jointed pavement blocks should consist of 2 inches of washed pea gravel. In most cases, this bedding layer can be placed directly over the gravel or stone layer. Depending on the void ratio of the stone layer, an additional layer of non-

woven geotextile may be needed between the stone and the overlying pea gravel as a separation barrier. The designer should specify geotextile if there is risk of the pea gravel sifting down through the stone layer.

- CGP: For grid paver with turf grass designs, first place a geotextile above the stone layer. Place 2 inches of soil/compost mix above the geotextile.

Step 9. Paving materials should be installed in accordance with manufacturer or industry specifications for the particular type of pavement. The basic installation process generally includes the following key procedures:

- PICP: Placed by hand or with mechanical installers. Fill the joints and openings with pea gravel. Remove excess stones from the paver surface. Compact and seat the pavers into the bedding course with a minimum low-amplitude 5,000-lbf, 75- to 95-Hz plate compactor. Do not compact within 6 ft of the unrestrained edges of the pavers.



This installation of pavers at a parking lot retrofit in Kailua Beach Park shows the underlying stone bed. A key to permeable pavement is the depth and void space of the stone bed where water is temporarily stored (photo: Hui o Ko'olaupoko).

The system must be thoroughly swept by a mechanical sweeper or vacuumed immediately after construction to remove any sediment or excess aggregate.

- CGP: Lay the grid pavers on the bedding soil and fill the void openings with additional soil/compost mix. Remove excess soil from the paver surface. Compact and seat the pavers into the bedding layer with a minimum low-amplitude 4,000-lbf, 75- to 90-Hz plate compactor. Do not compact within 6 feet of the unrestrained edges of the pavers. Seed surface soil/compost mix with turf grass. Initial watering is recommended to promote seed establishment.
- Fill gaps at the edge of the paved areas with cut pavers or edge units. When cut pavers are needed, cut the pavers with a paver splitter or masonry saw. Cut pavers no smaller than one-third (1/3) of the full unit size.
- Inspect the area for settlement. Any areas that settle must be reset and re-inspected.

- Inspect the facility 18 to 30 hours after a significant rainfall (1/2 inch or greater) or artificial flooding to determine whether the facility is draining properly

Avoiding Common Pitfalls

Permeable pavement technologies have come a long way in terms of performance, longevity, and costs. There are a few key design and installation snafus, however, that can plague your system. Some of the big pitfalls to avoid include: designing a surface that accepts excessive runoff from adjacent areas; compacting or clogging the system during construction; allowing for sloppy installation or inappropriate deviations from material specifications from suppliers; and failing to maintain the surface.

Table 4-5 summarizes some of common things that go wrong and how to avoid or address the issues during design review, installation, and maintenance phases of the project.



At this installation in American Samoa, soil filled spaces between grass pavers were hollowed out for planting of individual plugs. Using the proper soil mix and providing irrigation helped establish vegetation quickly.



Table 4-5. Tips to Avoiding Common Pitfalls

What Goes Wrong	How to Avoid/Solve it		
	Design and Review Tips	Installation Tips	Maintenance Tips
1. Permeable surfaces clog during construction/installation	On plans, note that permeable structure should not be installed until the site is stabilized. Plan should show clear sequencing of tasks to avoid construction runoff onto permeable surfaces.	Divert construction runoff around installation area. If designed for infiltration, avoid compaction of area by heavy equipment.	Keep fines out of permeable surfaces with leaf blowers or vacuum sweepers. Avoid high pressure washers. Clean pre-treatment areas.
2. Contractor deviates from technical specs or installation procedures	Design for the materials you can get and/or provide list of approved equivalents. Be thorough in construction notes, particularly as relates to joint materials for pavers, and temperatures and size of pours (for porous concrete/asphalt).	<ul style="list-style-type: none"> Use an experienced contractor where feasible Pour in small batches to ensure consistency and porosity (porous concrete/asphalt) 	Follow manufacturers' maintenance recommendations
3. Parking or travelways not designed for structural loads	Make sure the surface and subsurface designs are responsive to the anticipated structural loads, and not just storing the Practice Volume needed for water quality.	Conduct necessary structural load tests (e.g., CBR) during installation.	Monitor structure integrity and check for settling and slumping. Make necessary repairs.
4. Run-on from adjacent areas leads to failure	Avoid designs that accept excessive runoff from adjacent impervious cover (except for roofs). Permeable pavement systems should largely manage the rain that falls directly on its surface. Plan for pre-treatment if pervious areas drain onto permeable surfaces.	Make sure grading of adjacent areas is correct to avoid unintentional run-on	May require additional maintenance if run-on occurs
5. Structure does not drain quick enough to keep water off of surface	<ul style="list-style-type: none"> For infiltration designs, conduct a permeability (saturated hydraulic conductivity) test at the bottom elevation of the practice. If the rate is less than 0.5" per hour, consider a filter design with an underdrain (see Appendix D). For filter designs, ensure that underdrain sizes and slopes are suitable for wet season flows. For both types of design, provide an overflow structure about 2" above the pavement surface sized to handle expected wet season flows. An "overdrain" (perforated pipe) near the top of the stone layer, or other internal storage, can be used to ensure water will not pond on the pavement surface. 	<ul style="list-style-type: none"> It is imperative to protect the soil during construction to prevent disturbance and compaction. Keep heavy equipment out of the area. Ensure that underdrains, overdrains, and internal storage layers are perforated, the right size, set at the right slope, and tie into the appropriate downstream structures. 	If water ponds on the surface for long periods of time, conduct an investigation to identify the problem. It may be possible to retrofit in some type of overdrain or overflow system.

Island Case Studies

The following case studies are actual island applications. As such, the designs used may not adhere precisely to the specifications contained in this chapter. This chapter represents perhaps the ideal way to design and install permeable pavement systems, but the case studies illustrate that successful designs can be adapted to various conditions, availability of materials, and other factors.

Kailua Beach Park/Popoi'a Street, Oahu

Inspired by Hui o ko'olaupoko (HOK), a local watershed organization, this LID retrofit project replaced 12,000 sq. ft. of an existing public parking lot with permeable pavers and restored 360 feet of riparian habitat using native plants and rain gardens (**Figure 4-6**). The parking area is adjacent to Ka'elepulu Stream in Kailua, and the intent of the project was to reduce stormwater runoff via infiltration. Designed by Hughes and Hughes Landscape Architecture, LLC, the system included 12" sub-base of $\frac{3}{4}$ " stone and $\frac{1}{4}$ " stone bedding layer for the pavers, which were Aquastone™ product supplied by Futura Stone (for details go to www.futurastonehawaii.com/aquapave.nxg).

For more information on the project design, grant funding, partnerships, and community education and involvement, contact:

Todd Cullison
Executive Director
Hui o Ko'olaupoko
1051 Keolu Dr. #208
Kailua, HI 96734
808-277-5611 (p)
www.huihawaii.org

Rethinking Parking Lots

Existing Parking Lot at Popoi'a Street



Removal of existing pavement surfacing



Stone sub-base with geotextile fabric separating the sub-grade



Pavers installed and leveled over bedding stone



Final product, with improved riparian landscaping



Photos: Hui o Ko'olaupoko

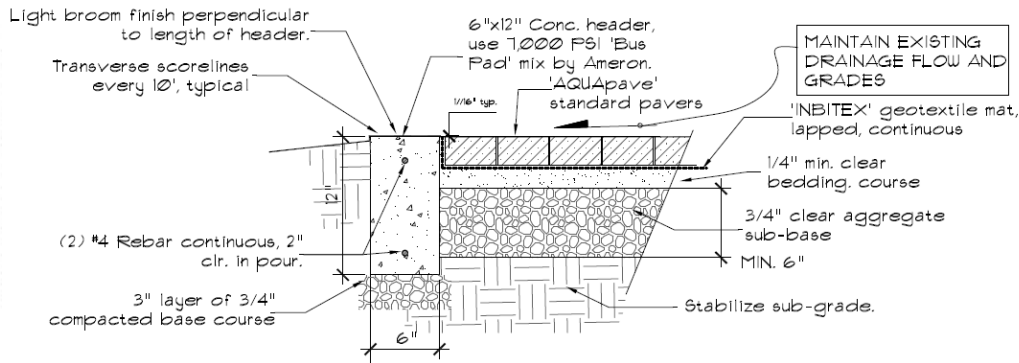

G "AQUA PAVE" INSTALLATION
 NO SCALE

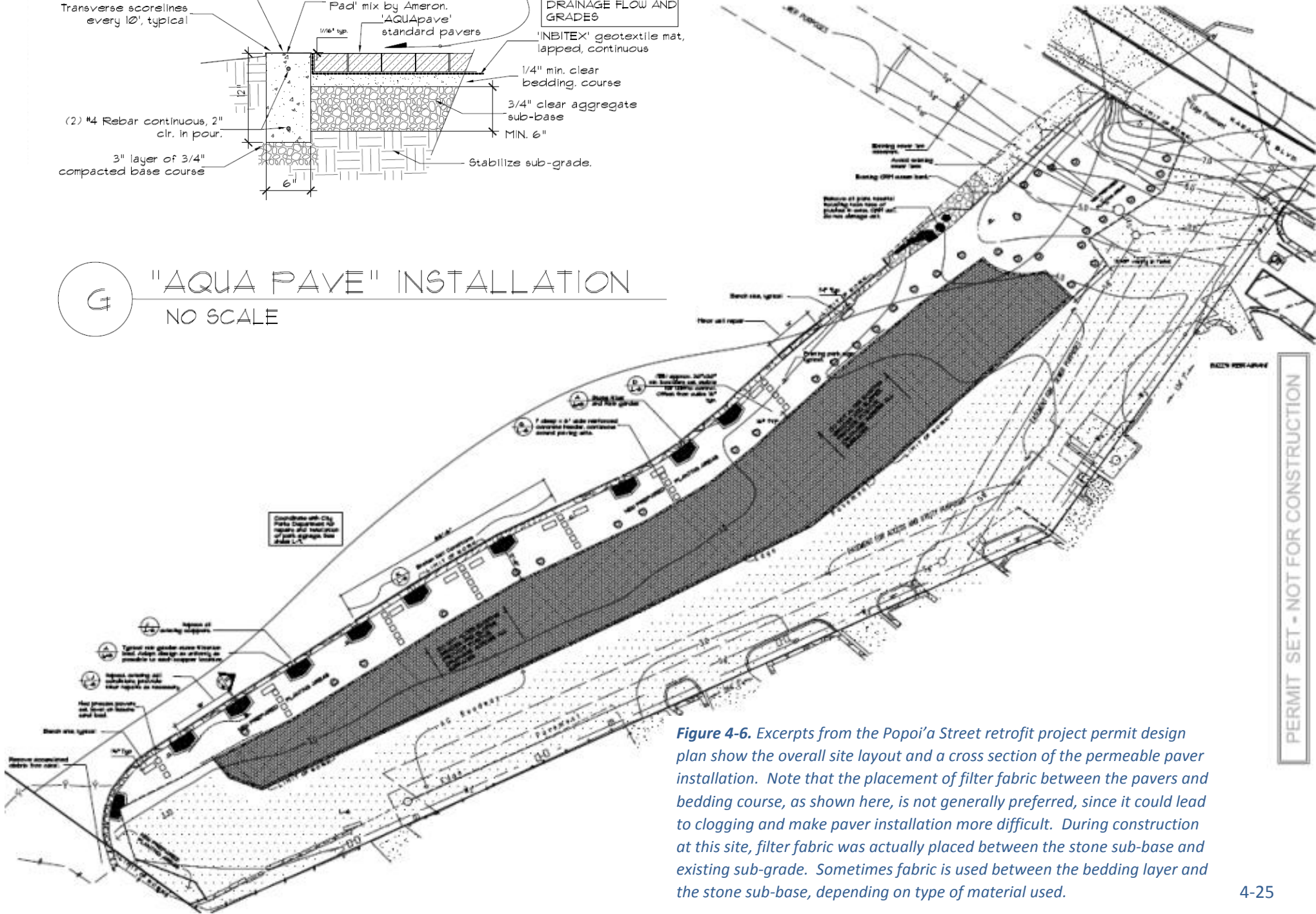

Figure 4-6. Excerpts from the Popo'i'a Street retrofit project permit design plan show the overall site layout and a cross section of the permeable paver installation. Note that the placement of filter fabric between the pavers and bedding course, as shown here, is not generally preferred, since it could lead to clogging and make paver installation more difficult. During construction at this site, filter fabric was actually placed between the stone sub-base and existing sub-grade. Sometimes fabric is used between the bedding layer and the stone sub-base, depending on type of material used.

American Samoa Environmental Protection Agency Office Building

The newly redeveloped American Samoa EPA office is one of the first LEED-certified buildings in the South Pacific. Design and construction oversight was provided by Brian Rippy with AS-EPA. LID was incorporated to reduce overall impervious cover and fulfill certification requirements, but also to test and showcase on-site stormwater practices on an island where few examples of LID exist. Funded in part by the NOAA Coral Reef Conservation Program, grass pavers were used both in drive aisles and parking stalls (as well as on the roof!) and permeable interlocking concrete pavers were used in the handicap parking stalls and walkways (**Figure 4-7**). Pavers were imported from Fiji, but could likely be manufactured on island in the future.

For more information on project design, construction and materials, or practice performance, contact:

Brian Rippy, LEED AP
Principal

Resilient Design Consulting

rdcdesign.net

Office: (819) 931-3775

Figure 4-7. Excerpts from the AS-EPA building construction plans show the locations of two types of permeable pavers and include a detail describing the type and depth of underlying aggregate.

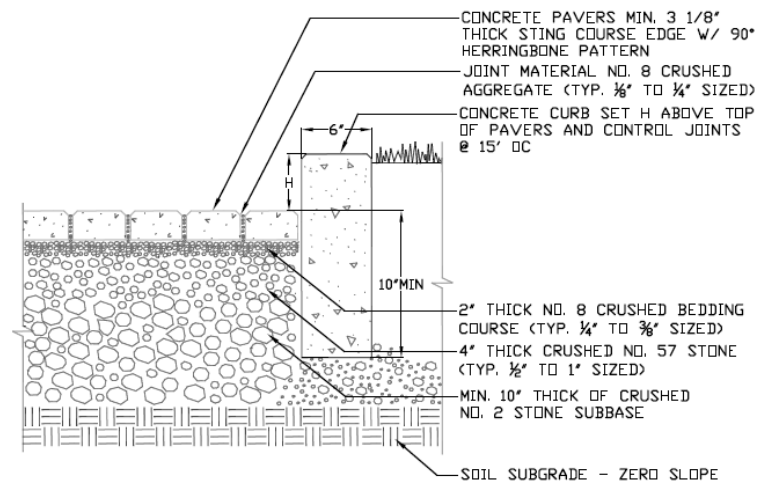
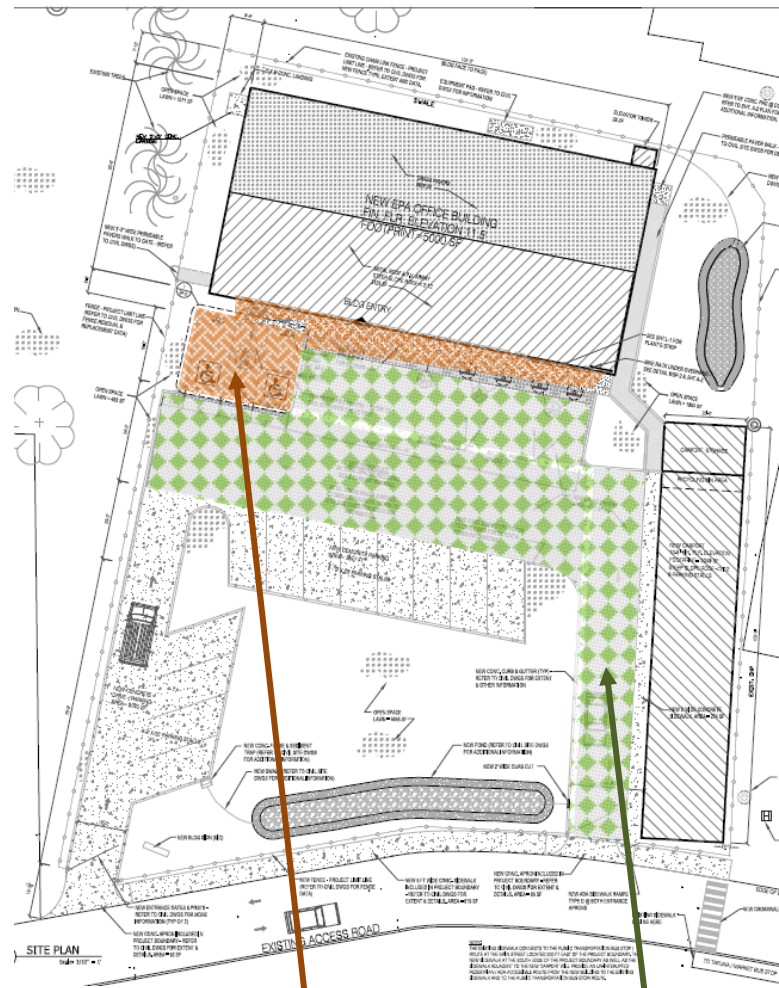

NOTES:

- H SHALL BE 6" FROM FINISHED ROADWAY GRADE UNLESS OTHERWISE SHOWN ON DRIVEWAY GRADING PLAN & PROFILE, DETAIL 15.
- CONSULT ICPI TECH SPEC 2 AND 3 FOR GUIDELINES ON SPECIFICATIONS FOR BASE MATERIALS, SUBGRADE SOIL AND BASE COMPACTION. (WWW.ICPI.ORG)

University of the Virgin Islands Research & Technology Park, 64 West Center

The 64 West Center located on UVI's St. Croix campus is a truly impressive example of new "green" building design and construction efforts in the Virgin Islands. On-track to gaining LEED certification status, the stormwater aspects of this facility include permeable pavements, vegetated bio-swales, underground detention storage (Rain Tanks™) for landscape irrigation and to supplement water supplies for water closets, urinals, and cooling tower. The rain tank installation is over 300 ft long by 11 ft wide with a storage capacity of 118,000 gallons (**Figures 4-8 and 4-9**).

The projected post-development runoff rates and volumes for the 1-, 2-, 10- and 100-year storm events are less than pre-developed conditions. This project reportedly helped reduce localized flooding issues that were occurring at the site prior to this development. A reduction in municipal water consumption of over 50% was estimated, as well as an annual savings on non-potable water consumption of 121% due to rainwater harvesting/reuse and water-saving devices.

For more information on project design, construction and materials, or practice performance, contact:

Jeremy Tyson
Project Manager
Engineering Solutions
ARAMARK Higher Education
Office: 340.773.5000
www.uvirtpark.com



Figure 4-8. Rain Tanks© installed below a grassed bioswale at the RTPark 64 West Center are used to collect rainwater for non-potable reuse including irrigation, toilet flushing, and cooling tower recirculation.

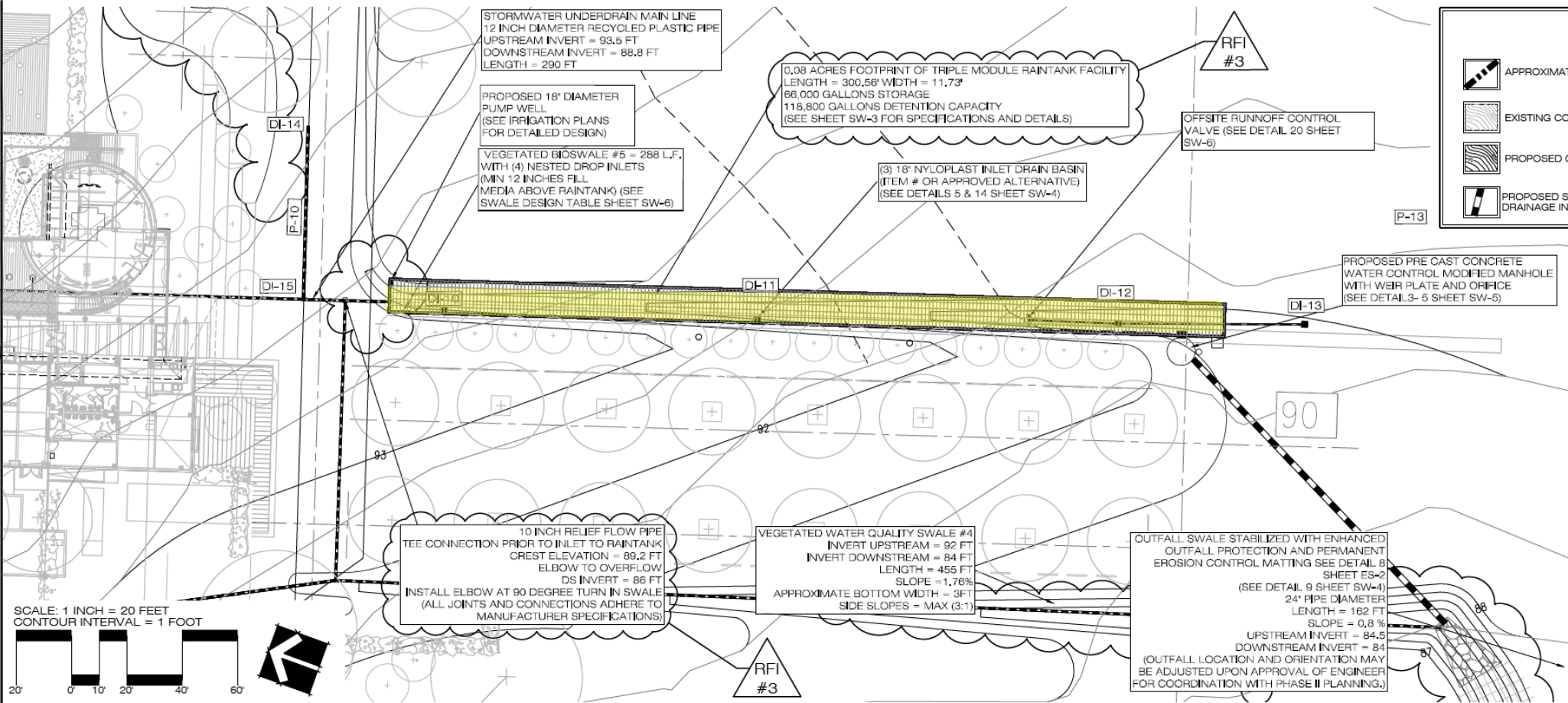

Legend:

- APPROXIMATE
- EXISTING CO
- PROPOSED C
- PROPOSED S DRAINAGE IN

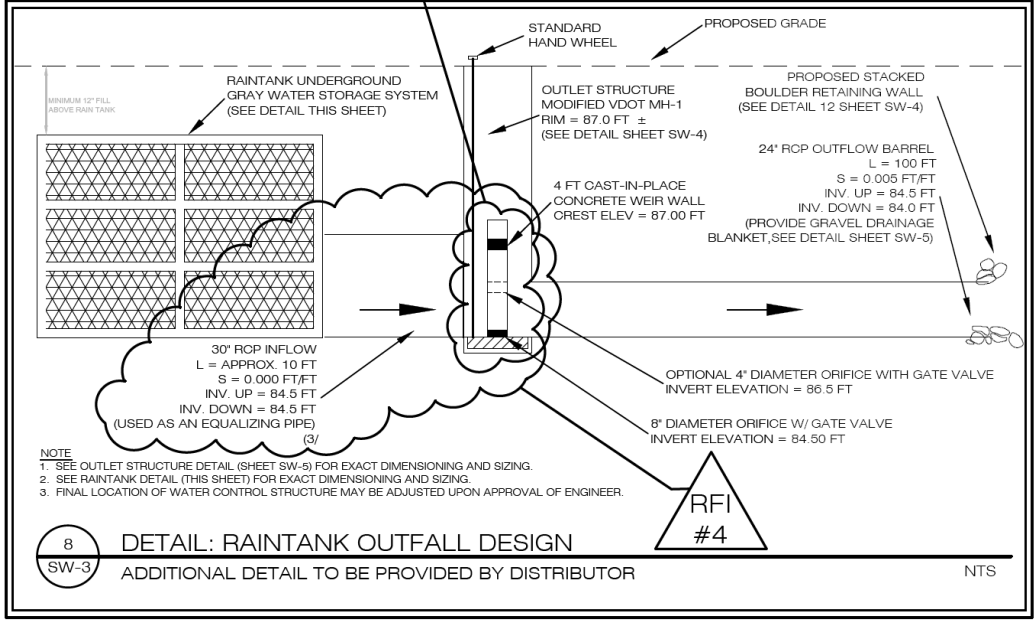
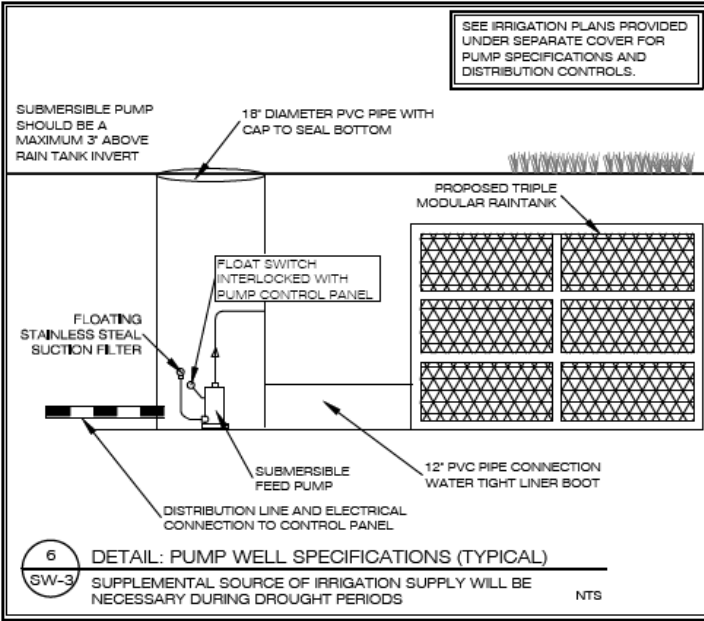
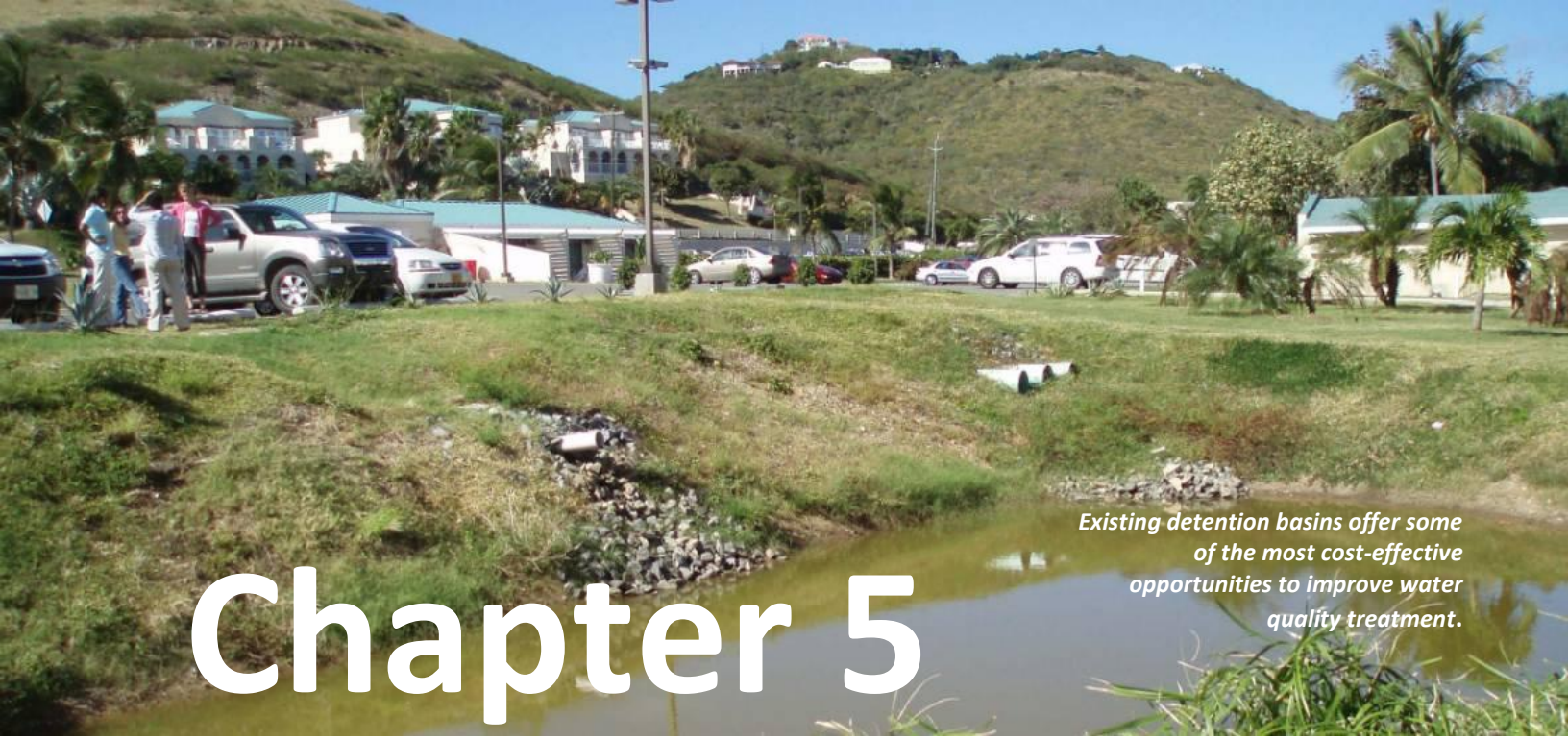

Figure 4-9. Excerpts from construction plan set for Rain Tanks™ system at the 64 West Center.



Existing detention basins offer some of the most cost-effective opportunities to improve water quality treatment.

Chapter 5

Improving Treatment Capacity of Existing Basins

Many jurisdictions already have an array of existing stormwater management practices, both new and old. Existing BMPs may include ponding basins, detention ponds, or sediment basins. Often, these practices were designed using older standards to address flooding or to control erosion during construction, but not long-term water quality treatment. In northern Guam, for example, ponding basins over limestone act like sinkholes, and have the potential to infiltrate polluted runoff into drinking water aquifers. In addition, many existing BMPs do not perform as designed due to lack of maintenance (e.g., clogging, filling with sediment and unmanaged vegetation), by-passing, under sizing, and/or substandard construction.

These existing practices are ideal candidates for retrofitting in order to improve water quality treatment. This can be done in the context of a redevelopment project or as part of a more holistic watershed restoration plan. Retrofits of existing ponding basins and other practices can be used to enhance water quality treatment, ensure that infiltrated stormwater does not contaminate groundwater, and provide downstream benefits for flood and channel protection. It is important with retrofits to investigate and understand the treatment objectives of the existing practice. For instance, if a BMP is providing storage to



Discharges from poorly designed detention basins can contribute unnecessarily to additional downstream watershed problems.

prevent downstream flooding, then maintaining adequate storage would be an important design consideration. However, many practices do not make full use of the storage they have or may be oversized for the original objective, so there are often ample opportunities to add features to enhance water quality treatment. In addition to retrofit scenarios, the designs in this chapter can be used in situations where a stormwater management pond or basin is required for a new development or redevelopment project.

Seizing the Opportunity

Retrofitting (or modifying) existing stormwater BMPs is a cost-effective way to improve water quality, since there is already infrastructure in place to collect and capture runoff. The following are some concepts for retrofitting existing BMPs, primarily ponding and detention basins:

1. Lengthen the flow path & hydraulic retention time. Many existing practices do not provide a high level of treatment because the pathway of the water from inlet to outlet is very short or the stored water exits the practice very quickly. Options for increasing treatment include creating a longer flow path between the inlet and the outlet, which allows the water to stay in the practice for an adequate length of time needed for settling, biological uptake, filtering through media, chemical adsorption, or other treatment mechanisms. Modifications of outlet orifices and embankment heights can also be used in combination to help extend detention times.

2. Use vegetation to enhance treatment. Often with existing detention basins, management of vegetation is not well thought-out. As a result, many existing practices are either mowed and manicured or left to grow wild. Vegetation can be an important part of the treatment process, but this must be reflected in a planting plan that is maintained over time. Vegetation can be used to promote settling, biological uptake, and chemical processing. Retrofits can include wetland cells, vegetated swales, and revegetation.

3. Add Pretreatment. Most existing ponds do not include pre-treatment cells to settle out the heaviest sediment particles from incoming runoff. Pre-treatment is critical to preserving the life span of a practice (prevent clogging), as well as maintaining the treatment performance of the practice surface area.

4. Add Filtering Layers. Many existing practices in the islands have a more-or-less direct connection to groundwater (e.g., ponding basins in the Pacific). Others discharge directly to surface or coastal waters. For this reason, the discharge water quality is very important. Adding sand or compost filter layers to an existing practice can help boost pollutant removal for a variety of pollutants (e.g., sediment, bacteria, nutrients, metals), and this can do a better job of protecting downstream waters and groundwater.

Table 5-1 summarizes common options for improving existing BMPs. **Figure 5-1** shows retrofitting examples.



This basin in American Samoa could provide improved water quality treatment with minor design and landscape enhancements.



This detention basin in Garapan, CNMI takes up valuable space and is not very attractive.



Standing water in this ponding basin on Guam is an indication that the basin bottom is clogged, which prevents infiltration.



Large detention basin with outlet structure on Maui used for flood control.



The Kingshill Road detention basin is a stormwater retrofit designed to manage runoff from surrounding roads and residential areas as part of watershed restoration efforts led by the Coral Bay Community Council on St. John. Vegetation survival and sediment accumulation rates are being closely monitored for maintenance and future design purposes.

Table 5-1. Common Retrofit Options for Existing Practices

Retrofit Strategy	Applications	Examples
<p>1. Lengthen the flow path and hydraulic retention time</p>	<p>This strategy can be used for most existing ponds, with the approach depending on the geometry of the practice. Common strategies include creating a circuitous channel through the practice, using internal baffles or weirs to divert water along a lengthened flow path, or creating multiple cells divided by overflow weirs or spillways.</p>	
<p>2. Rethink vegetation as part of the treatment process</p>	<ul style="list-style-type: none"> • Convert a dry detention pond to a constructed wetland • Use vegetated swales as part of the strategy of lengthening the flow path, as described in #1 above. • Incorporate vegetated filters within the practice footprint. 	
<p>3. Add Pretreatment</p>	<ul style="list-style-type: none"> • Create a sediment forebay or separate cell at or near the inflow point. • For smaller drainage areas, use vegetated filter strips or grass swales up-gradient of the practice. 	
<p>4. Add Filtering Layers</p>	<ul style="list-style-type: none"> • Add a sand or compost filter in the practice floor or perhaps as part of a “treatment train” approach. • For heavily compacted areas, add soil amendments to the practice bottom or selected flow path area. • For some applications, use a subsurface gravel wetland design. 	

Figure 5-1. Seizing The Opportunity to Improve Existing Practices



This ponding basin is designed for storage and infiltration near Guam’s Harmon sinkhole, an important groundwater recharge site.



In ponds, the placement of the inlet and outlet are important flow path considerations.

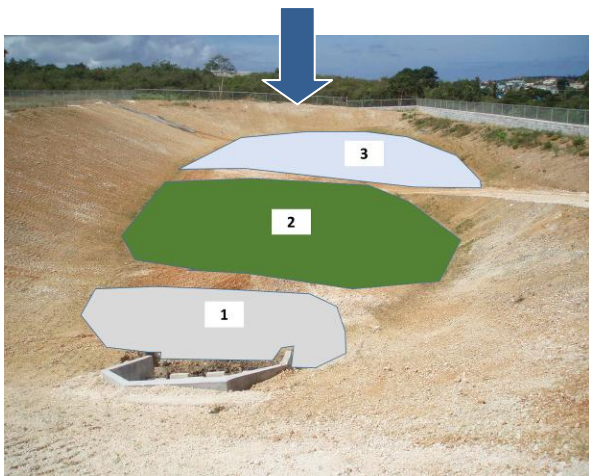

In subsequent years following construction, tall grasses have become established within the basin, however, improvement on design could help enhance the water quality treatment performance of this facility. Options include:

1. Add a sediment forebay at the inlet
2. Add a vegetated filter cell
3. Modify the infiltration bed

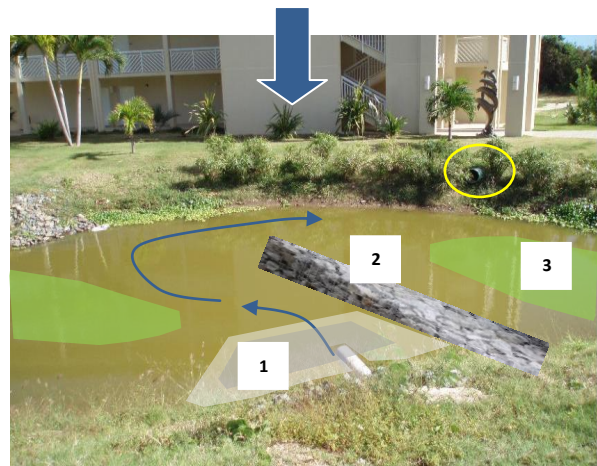

Where feasible, consider installing forebays for easy maintenance and in-pond features to improve aesthetics and increase flow paths. This pond, for example, could be redesigned as more of a constructed wetland (if the water table can maintain a permanent pool). Options include:

1. Add an energy dissipator/concrete forebay
2. Increase the flow path and residence time using gabion baskets
3. Add wetland plants to increase pollutant uptake, particularly for nitrogen.

Retrofitting Existing Ponds

There are many ways to retrofit an existing ponding or detention basin. Some are very simple, such as:

- Modifying the riser or outlet structure to better treat small storm flows and allow for settling.
- Adding vegetation to the flow path.
- Adding berms or gabions to lengthen the flow path.
- Adding a simple forebay at each inlet.
- Restoring capacity by dredging out accumulated sediment.
- Unblocking clogged orifices, inlets, etc.

These are worthy efforts and will lead to better practice performance. Other approaches, however, take a more comprehensive approach to redesign the practice to accomplish a broader set of objectives.

The remainder of this chapter will focus on two options for this type of retrofit (or for a new basin design):

- 1. Limestone/Infiltration Design – Multi-Cell Ponding Basin:** In many island limestone regions, the stormwater practice of choice has been the ponding or infiltration basin. In essence, this is simply an excavated basin that allows stormwater to infiltrate into the underlying limestone features. These can be enhanced to provide better water quality treatment –for discharges to surface water and, perhaps more importantly, underlying groundwater systems. This type of retrofit can be referred to as a “multi-cell ponding basin.” See **Figures 5-2** and **5-3** for typical details for a multi-cell ponding basin and flow splitter.

- 2. Stormwater Wetland Design:** On sites where volcanic or clayey soils, a high water table, or other factors limit infiltration, the practice of choice has been the wet detention basin designed for flood and peak rate control. There are ample opportunities to enhance these BMPs by adding constructed wetland and flow path features to improve water quality treatment. Some designs convert the entire basin floor area into wetland features (see **Figure 5-4**), while others incorporate an open water wet pond into the wetland cells (see **Figure 5-5**).



Ponding basins for infiltration (top) and wet ponds that maintain a permanent pool (bottom) can often be improved to increase treatment performance.



This inlet channel at AS-EPA is designed to trap sediment and debris between brick steps.



Vegetation in this basin on St. Thomas provides treatment, but requires management.

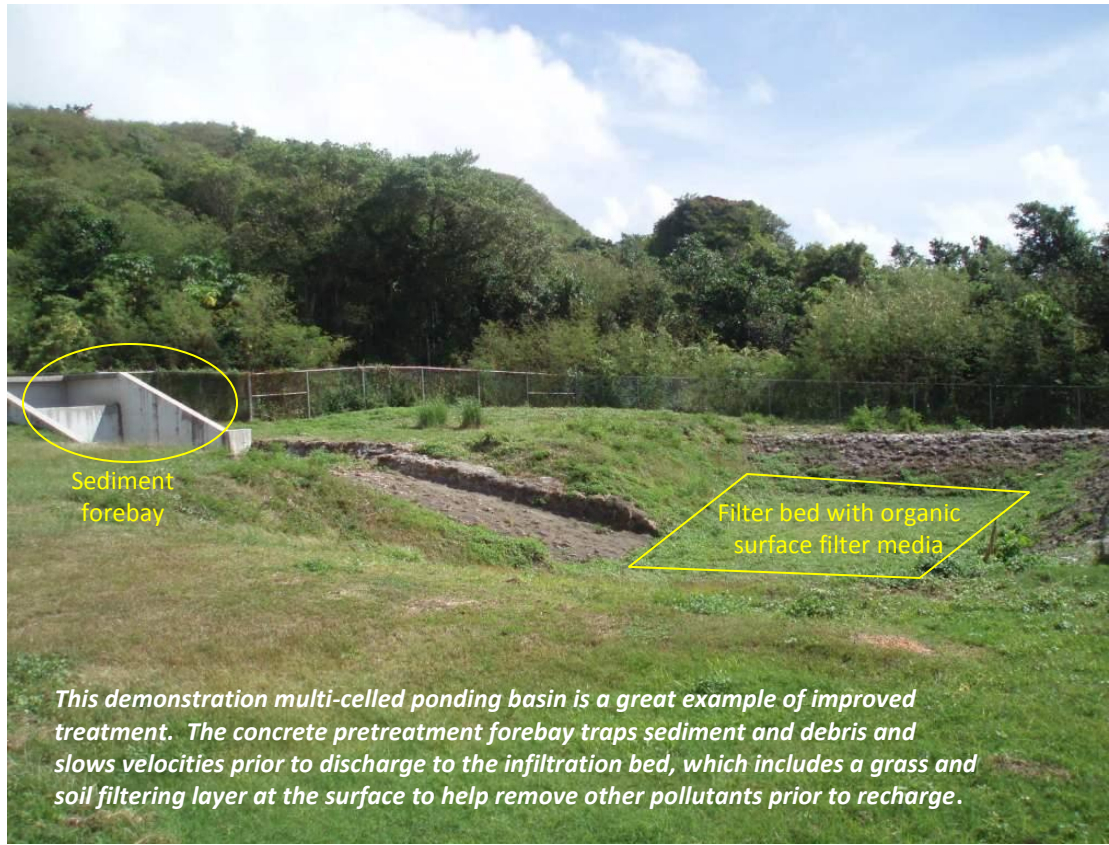

Sediment forebay

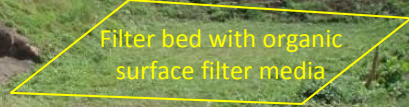

Filter bed with organic surface filter media

This demonstration multi-celled ponding basin is a great example of improved treatment. The concrete pretreatment forebay traps sediment and debris and slows velocities prior to discharge to the infiltration bed, which includes a grass and soil filtering layer at the surface to help remove other pollutants prior to recharge.



A small stormwater pond at a private company on Guam manages parking lot runoff. The design includes a grass pretreatment swale, in-pond vegetation, and an overflow structure with properly maintained access.



This constructed stormwater wetland on Saipan was designed with an extended flow path and strategically-placed wetland plants to promote settling of solids and plant uptake of pollutants.

Another design variant– the subsurface gravel wetland – is particularly suited for removing nutrients, such as nitrogen, and for fitting into tight spaces. See **Figure 5-6** for typical details of this type of filter design. As shown, stormwater first goes through a sediment forebay and is piped up into the gravel media of the main cell from the bottom, which reduces the amount of standing surface water.

While this chapter will not provide detailed guidance on subsurface gravel wetlands, the 2012 Rhode Island Stormwater Manual has some of the most recent design guidance on this practice. Gravel wetlands could be useful in some island settings; however, this technology currently appears to be absent in the Caribbean or Pacific islands. Similar designs for wastewater treatment systems are relatively common.

Tables 5-2 and **5-3** provide details and notes for the design components of the Multi-Cell Ponding Basin and Stormwater Wetland design, respectively.

This detention basin on Guam is currently being used for erosion and sediment control. The inlet pipe (under the orange safety cone) is located adjacent to the outlet riser (black stand pipe), which will ultimately short-circuit the flow path.



Outlet structure

Inlet pipe

Figure 5-2. Plan View and Longitudinal Section for Multi-cell Ponding Basin

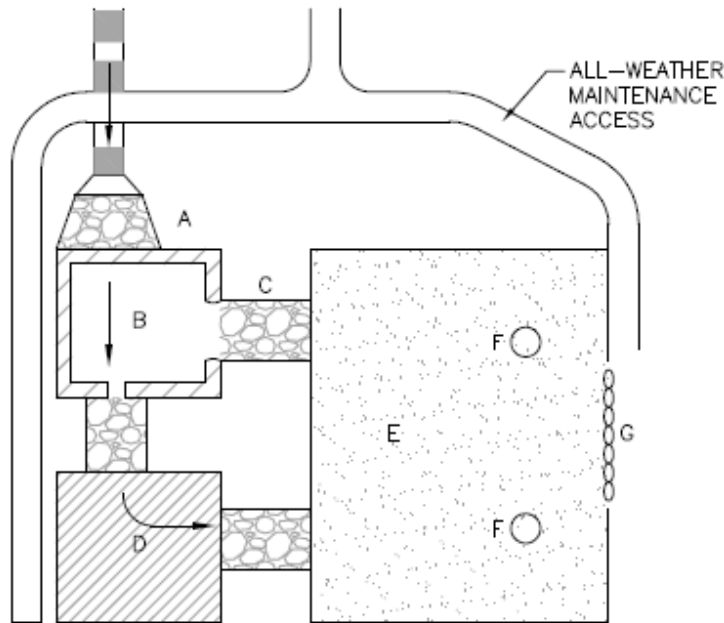

PLAN

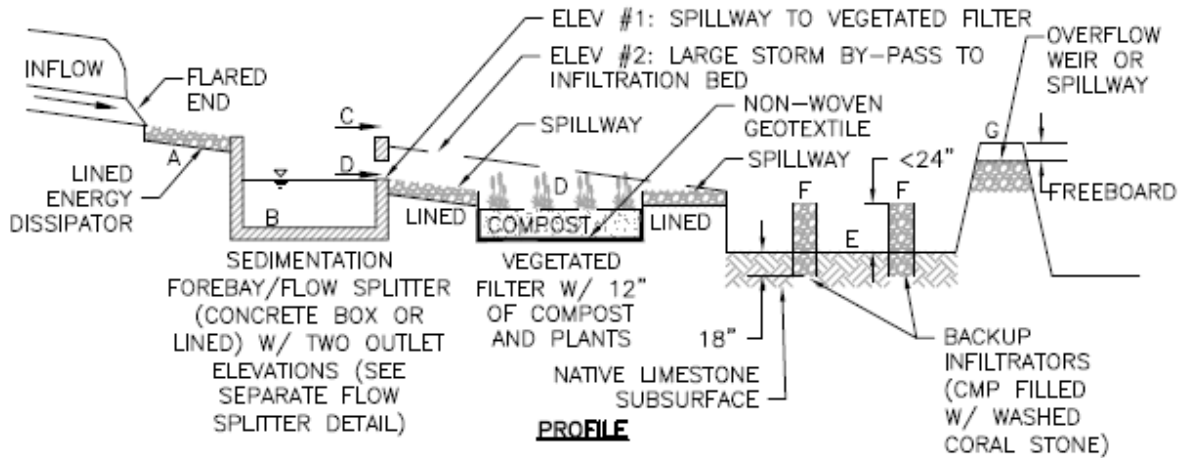

PROFILE

$$P_v = B + D$$

$$B \geq 25\% \text{ OF } WQ_v$$

$$D \geq 75\% \text{ OF } WQ_v$$

$$Q_{pas} = E$$

- A = ENERGY DISSIPATOR
- B = SEDIMENT FOREBAY & FLOW SPLITTER (CONCRETE BOX OR LINED)
- C = LARGE STORM BY-PASS
- D = VEGETATED FILTER
- E = INFILTRATION BED (IRREGULAR SHAPE)
- F = BACKUP INFILTRATORS (1 PER 1,000 SF OF BED SURFACE)
- G = OVERFLOW WEIR/SPILLWAY TO STABLE OUTLET

MULTI-CELL PONDING BASIN

NOT TO SCALE

Figure 5-3. Flow Splitter Detail (see Figure 6-2 for location of flow splitter in the multi-cell ponding basin system).

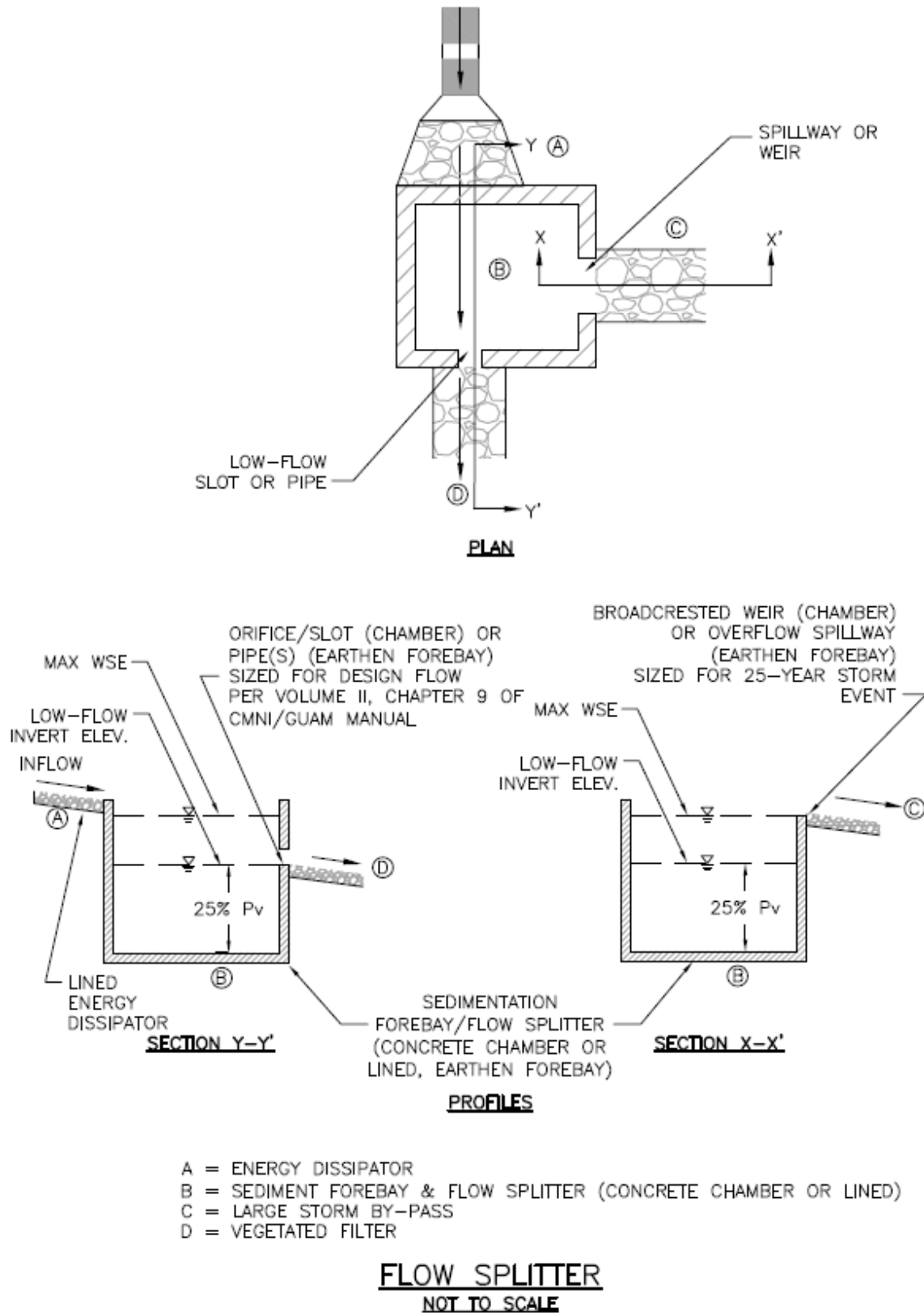

Table 5-2. Description of Multi-Cell Ponding Basin Design Components

Material*	Specification	Notes
Energy Dissipator (A) and Spillway (C and G) Stone	<ul style="list-style-type: none"> Use riprap or other available hard, angular stone of appropriate size, such as clean, washed stone; (minimize amount of “dust”) or washed, broken concrete. Place at inlets and along spillways to dissipate energy and prevent erosion Size riprap or acceptable alternative per Federal Highway Administration criteria based on the peak velocity from the 10-year storm event. 	
Geotextile or Filter Fabric for Lining the Energy Dissipator (A) and Spillway (C)	<ul style="list-style-type: none"> Filter fabric or equivalent. Place as shown on the typical detail in Figure 5-2. 	
Sedimentation Forebay/Flow Splitter (B)	<ul style="list-style-type: none"> Shown in greater detail in Figure 5-3. Construct in concrete box or earthen forebay with riprap (or alternative) and impermeable liner. Size for 25% of the Practice Volume (P_v) Outlet orifice/slot (if concrete box) or pipe (if earthen forebay) to filter bed (D) should be sized based on expected flow rate for the P_v flow (see CNMI and Guam Stormwater Manual for guidance on calculating flow rate). Outlet weir (if concrete box) or spillway (if earthen forebay) for the large storm by-pass (C) should be sized based on expected wet season peak discharges, such as the Q_{p-25} Forebay can be equipped with a metered rod in the center of the pool for long-term monitoring of sediment accumulation. Depending on the type and scale of the application, other pre-treatment options may be acceptable as long as the sizing criteria are met. 	The sedimentation forebay/flow splitter provides pretreatment for the filter bed (D) as well as a bypass (C) for larger storm flows to prevent overwhelming the filter bed.
Impermeable Liner (for use with earthen forebay)	<ul style="list-style-type: none"> Use a thirty mil PVC Geomembrane liner covered by 8 to 12 oz./sq. yd. non-woven geotextile (or equivalent) to protect the liner from puncture. 	Use impermeable liners to line the forebay/flow splitter (B) if a concrete structure is not used.
Soil/Compost Media for Vegetated Filter Bed (D)	<ul style="list-style-type: none"> Follow guidance in Soil/Compost Media spec. (Appendix C) Minimum 12” in vegetated filter cell Filter bed surface should generally be flat to promote uniform filtration across the surface. 	It will be necessary to find a suitable soil/compost or sand mix. This mix will likely come from a topsoil or sand vendor or other local source. Other compost media or sand mixtures may be substituted if tested and approved by the plan-approving authority
Geotextile for Lining the Vegetated Filter Bed (D)	<ul style="list-style-type: none"> Needle-punched, non-woven geotextile fabric with a flow rate > 110 gal./min./sq. ft. Place as shown on the typical detail in Figure 5-2. If an underdrain is used for the vegetated filter bed, place geotextile between the soil/compost media and the underdrain stone. 	Do NOT place impermeable liners under the soil/compost layer OR between soil/compost and underdrain stone.
Free Storage Above Filter Bed (D)	6 – 12”, with 6” recommended	Control ponding level with outlet invert to the infiltration bed (E).

Material*	Specification	Notes
Plant Materials for Vegetated Filter Bed (D)	Plant a mix of mostly herbaceous and shrub species in the vegetated filter bed, with trees around the perimeter for larger applications. Choose species from the plant list in Appendix B .	Establish plant materials as specified in the landscaping plan and the recommended plant list. In general, plant spacing must be sufficient to ensure the plant material achieves 80% cover in the proposed planting areas within a 2-year period.
Underdrains & Cleanouts (only for filter bed designs in soils that require underdrain – not shown in Figure 5-2) (D)	<ul style="list-style-type: none"> • 4 – 6” inch rigid schedule 40 PVC pipe (or equivalent corrugated HDPE for small applications) • 3/8” perforations at 6 inches on center • Perforations only below filter bed • Minimum slope = 0.5%; 1% recommended • Position underdrain pipes ≤ 20’ apart • Clean-outs non-perforated & tied to underdrain with elbow; all clean-outs capped at surface • Lay the perforated pipe under the length of the filter bed, and install non-perforated pipe as needed to connect with the downstream infiltration bed. Install T’s and Y’s as needed, depending on the underdrain configuration. Extend cleanout pipes to the surface with vented caps. 	Only use underdrains when soils in filter bed area have slow infiltration rates. Underdrains must discharge to infiltration bed (E).
Underdrain Gravel or Stone Layer (only for filter bed designs in soils that require underdrain – not shown in Figure 5-2) (D)	<ul style="list-style-type: none"> • Clean, washed 1-inch gravel (preferred if available) or stone; minimize amount of “dust” (very fine particles) • Place underdrain pipe in 12” of underdrain stone 	This layer serves as an underdrain in cases where soils under the filter bed have slow infiltration rates.
Infiltration Bed (E)	<ul style="list-style-type: none"> • Provide storage for larger storm flows needed for flood control and/or channel protection, such as the Q_{p-10} or Q_{p-25}. • Excavate basin into native limestone subsurface with high infiltration rates • Provide an overflow weir or spillway (G) for storms > design storm event 	Designer must perform infiltration testing at site to determine infiltration rate to use for sizing bed. See sizing guidelines in Appendix D .
Backup Infiltrator (F)	<ul style="list-style-type: none"> • Use ≥24” CMPs or RCPs set vertically in the infiltration bed (E) with a maximum top elevation at 24” above the infiltration bed and a minimum of 18” deep into the native limestone subsurface. • Fill with clean, washed gravel or stone; minimize amount of “dust” (very fine particles). • Place one infiltrator per each 1,000 SF of bed surface. 	These are provided as emergency backup in case the infiltration bed becomes clogged. Designer should consult underground injection control regulations to determine regulatory status of design.
Overflow Weir/Spillway to Stable Outlet (G)	<ul style="list-style-type: none"> • Since most ponding basins are on-line facilities, they need to be designed to safely pass a large design storm (e.g., the 10-year, 25-year, and 100-year design storms). • The weir or spillway must outfall to an adequate conveyance or overland flow route. 	The design of the overflow weir or spillway should use a conservative approach and assume partial or full clogging of the infiltration bed.

* Letters correspond to labels in **Figures 5-2 through 5-3**

Figure 5-4. Typical Profile for a Stormwater Wetland Design

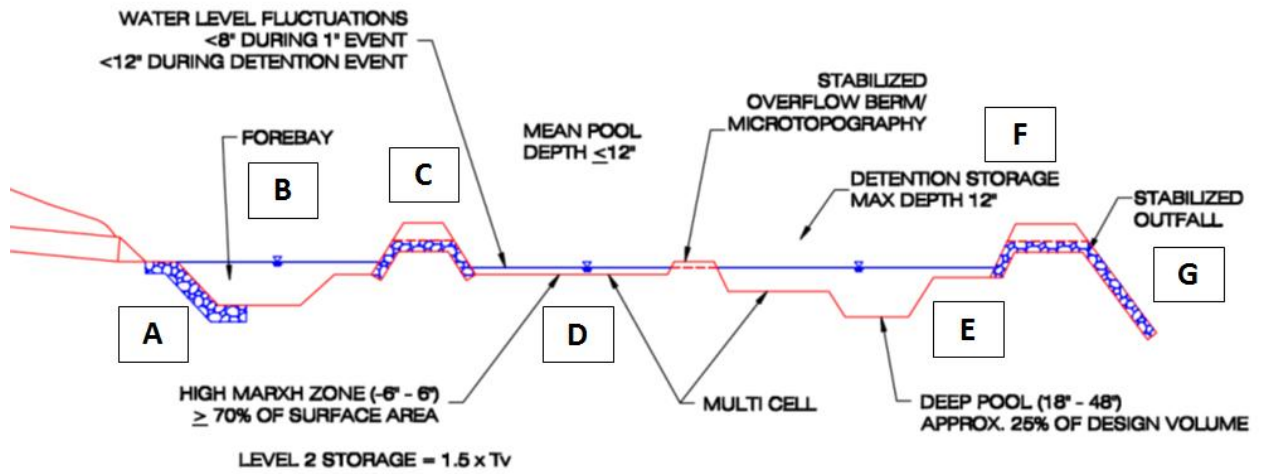

Figure 5-5. Typical Plan View and Profile for a Combined Stormwater Pond/Wetland Design

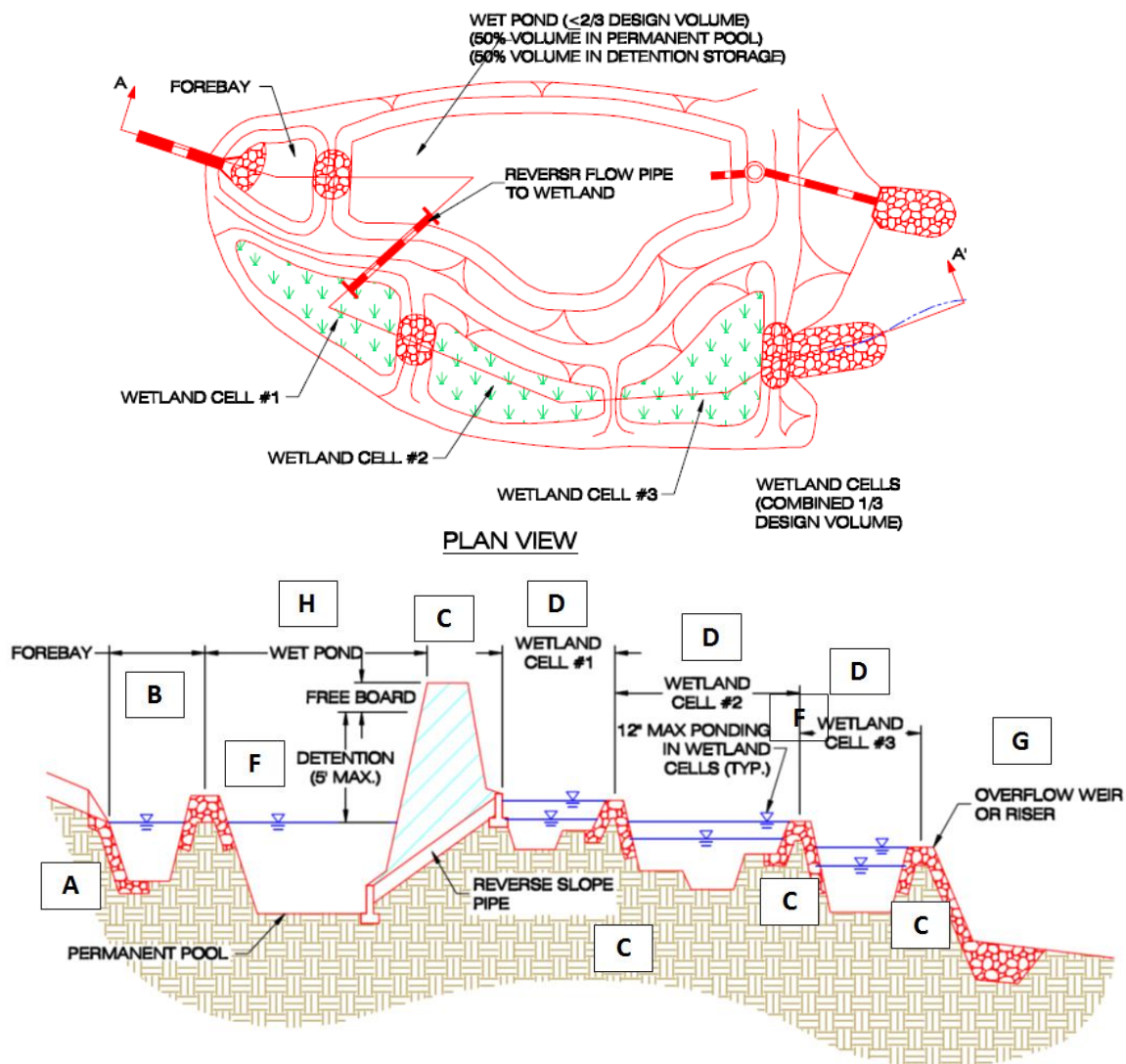
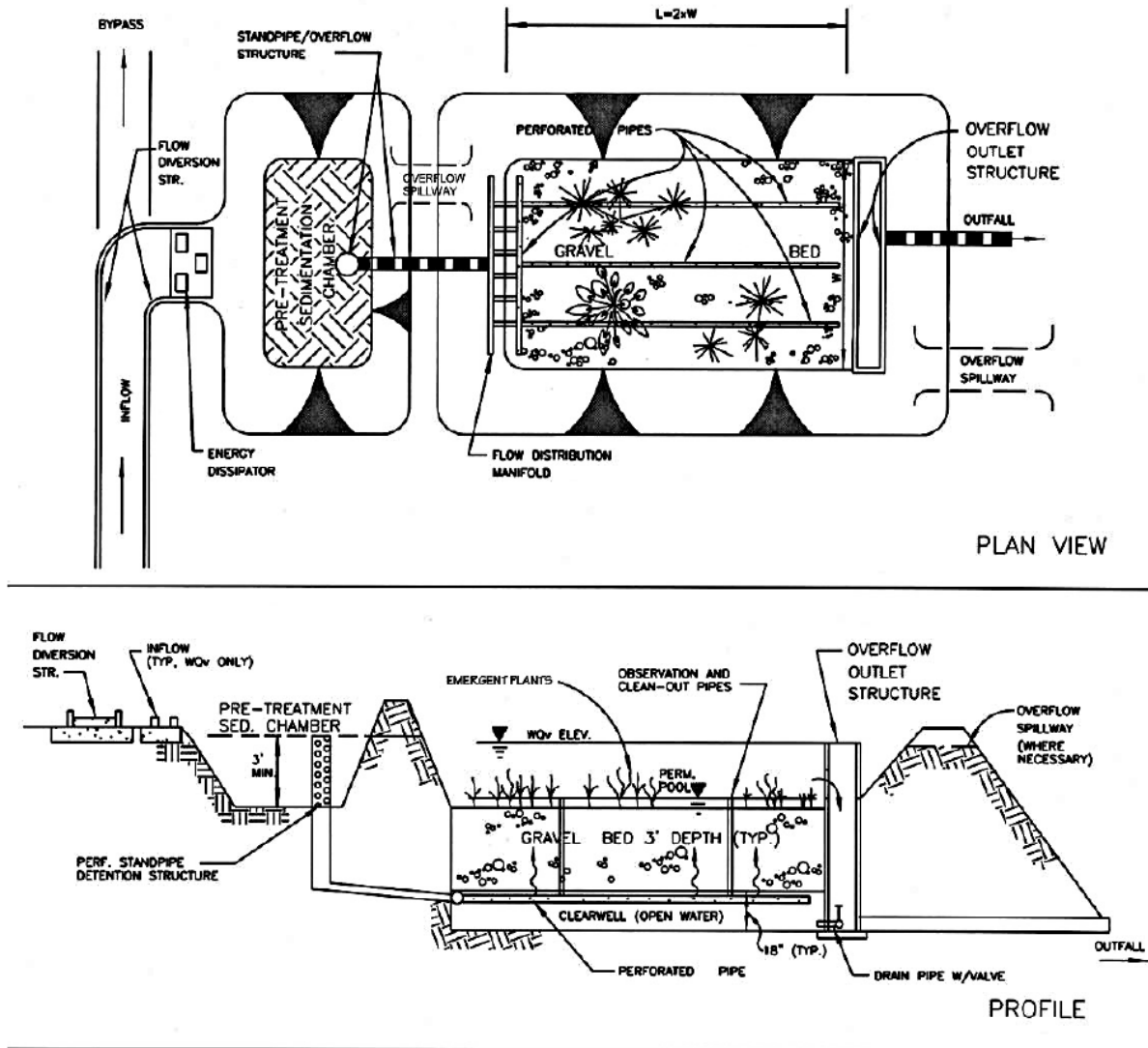

Figure 5-6. Plan View and Longitudinal Section for a Subsurface Gravel Wetland Design



Example gravel wetland installation in Harvard, Massachusetts. The cell on the left is the pretreatment sediment forebay with perforated standpipe that conveys flows into the bottom of the gravel bed in the lower chamber. The flow is forced up through the gravel to the surface where roots of emergent plants take up nutrients.

Table 5-3. Description of Stormwater Wetland Design Components (Figures 5-4 and 5-5)

Material*	Specification	Notes
Energy Dissipator (A) and Spillway Between Cells (C)	<ul style="list-style-type: none"> • Use riprap or other available hard, angular stone of appropriate size, such as clean, washed stone; (minimize amount of “dust”) or washed, broken concrete. • Place at inlets and along spillways to dissipate energy and prevent erosion • Size riprap or acceptable alternative per Federal Highway Administration criteria based on the peak velocity from the 10-year storm event. 	--
Geotextile or Filter Fabric for Lining the Energy Dissipator (A) and Spillway (C)	Filter fabric or equivalent.	--
Sedimentation Forebay (B)	<ul style="list-style-type: none"> • Earthen forebay with impermeable liner at each major inlet point. • Formed by an acceptable barrier (e.g., an earthen berm, concrete weir, gabion baskets, etc.). • Maximum of 4 feet deep, transitioning to 1 foot deep at the entrance to the first wetland cell. • Should include shallow vegetated bench around the perimeter that provides for both habitat and safety. • Bottom of forebay may be hardened (e.g., with concrete, asphalt, or grouted riprap) to make sediment removal easier. • Can be equipped with a metered rod in the center of the pool for long-term monitoring of sediment accumulation. • Spillway leaving the forebay should be sized for a large storm event, such as the Q_{p-25} 	The sedimentation forebay provides pretreatment for the pond and/or wetland cells (D), and captures the heavier sediment particles. The intent is that the forebay can be cleaned out on a regular basis, reducing the long-term maintenance burden for the other cells.
High Marsh Zones (D)	<ul style="list-style-type: none"> • Approximately 70% of the wetland surface area should be in the high marsh zone (-6 inches to +6 inches relative to the normal pool elevation). • Divide the high marsh zone into two or more cells, divided by berms or weirs. 	Select appropriate plant species for the expected inundation zone. See (H) below.
Deeper Pools, Stormwater Wetland Design only (E)	<ul style="list-style-type: none"> • Most of the remaining wetland surface area should be provided in at least three deeper pools – located at the forebay (B), center, and outlet (micro-pool) of the wetland. Each deep pool should have a depth of 18 to 48 inches. • Deep pools should have a shallow safety bench around the perimeter, approximately 12” below the normal pool elevation. 	--
Detention Storage Above Normal Pool for Larger Storms & Flood Control or Channel Protection (F)	<ul style="list-style-type: none"> • Size as needed to maintain storage for flood control and channel protection. • Should extend a maximum of 12” above the normal pool in the wetland cells. • If the design incorporates a wet pond (see Figure 6-5), the fluctuation may be greater in the wet pond footprint. 	Control the normal pool elevation with spillway (G).

Material*	Specification	Notes
Spillway/Stabilized Outfall (G)	<ul style="list-style-type: none"> • Since most Stormwater Wetlands are on-line facilities, they need to be designed to safely pass a large design storm (e.g., the 10-year, 25-year, and 100-year design storms). • While many different options are available for setting the normal pool elevation, one option is to install removable flashboard risers due to their greater operational flexibility to adjust water levels following construction. A weir can be designed to accommodate passage of larger storm flows at relatively low ponding depths. 	--
Plant Materials for Wetland Cells and Site Landscaping	<ul style="list-style-type: none"> • Plant mix of herbaceous (emergent), shrub, and tree species. Choose native species where available, and match species with various inundation and depth zones. • The planting plan should outline a realistic, long-term planting strategy to establish and maintain desired wetland vegetation. The plan should indicate how wetland plants will be established within each inundation zone (e.g., wetland plants, seed-mixes, volunteer colonization, and tree and shrub stock) and whether soil amendments are needed to get plants started. • Include a plant schedule and planting plan specifying emergent, perennial, shrub and tree species, quantity of each species, stock size, type of root stock to be installed, and spacing. 	<p>To the degree possible, the species list for the stormwater wetland should contain plants found in similar local wetlands and that are commercially available.</p> <p>Carefully consider whether to use aggressive colonizers, as they will quickly take over the entire planting area.</p>
Wet Pond Cell for Stormwater Pond/Wetland Design (optional) (H)	Use a flow splitter or diverter to divert flow associated with the 90th or 95th percentile storm to the wetland cells, and higher flows to the wet pond cell OR use a reverse slope-pipe from the wet pond cell into the wetland cells (see Figure 5-5)	The pond/wetland combination design involves a wet pond cell in parallel or series with wetland cells. Small storms (e.g., those associated with the 90 th percentile storm event or less) flow through the wetland cells while diverting the larger storm runoff into the wet pond cell. This is so the wetland cells are not subject to the higher water level fluctuations associated with rising and falling detention storage.
Impermeable liner	May be needed in some applications (i.e., limestone) where liner is needed to maintain a permanent pool, for example.	

* Letters correspond to labels in **Figures 5-4 through 5-5**.

Sizing Multi-Cell Ponding Basins & Stormwater Wetlands

The system should be sized to meet overall management objectives. See **Chapter 2** for a suggested methodology for identifying performance standards and treatment objectives, and translating these into a target volume for the BMP – referred to as the **Practice Volume (P_v)**. **Boxes 5-1** and **5-2** outline methods for allocating storage within multi-cell ponding basins and stormwater wetlands, respectively. The letters in the tables refer to the typical details in **Figures 5-2** through **5-5**. It is important to note that in retrofit situations

(modifying an existing practice), it may not be possible to achieve the full P_v , as outlined in **Chapter 2**. In these cases, the designer and local plan review authority should work together to determine an acceptable P_v based on available practice footprint and geometry and the local treatment objectives. In many cases, achieving at least 50% of the target P_v still constitutes a very worthwhile retrofit project. If the application is for a new development or redevelopment project that must receive local plan approval or permits, the design should strive to achieve the full P_v .

Box 5-1. Sizing a Multi-Cell Ponding Basin to Meet Treatment Objectives

Important Notes:

- The Practice Volume (P_v) is the storage provided by the practice to meet water quality or runoff reduction goals. See **Chapter 2** for the overall methodology for determining the P_v .
- Sizing Equations Reference the Typical Details in **Figures 5-2** through **5-3**.
- Most of these retrofits will have to still maintain the hydrologic function of the original practice for downstream flood/peak rate control and/or channel protection. This can be accomplished with storage in the infiltration bed (E), while the water quality Practice Volume (P_v) for smaller storms can be allocated to the forebay and vegetated filter cell (B + D).

$$\text{Practice Volume } (P_v) \leq V_{sf} + V_{fb} + V_{sc}$$

Where:

V_{sf} = Storage volume of sediment forebay = volume of storage x 1.0 (cubic feet)

V_{fb} = Storage volume of free storage above the filter bed = free storage x 1.0 (cubic feet)

V_{sc} = Storage volume of soil/compost layer in the vegetated filter = volume of soil/compost x 0.25 (cubic feet)

A general approach for calculating storage and sizing for the infiltration bed for larger storms (flood control, channel protection) is as follows:

$$\text{Required Storage} = Q_{is} - P_v \leq V_{ib} + (SA_{ib} \times f_c \times T / 12)$$

Where:

Q_{is} = Storage volume required for larger storms for flood control and/or channel protection (cubic feet)

P_v = Practice Volume, as calculated above (cubic feet)

V_{ib} = Storage volume of infiltration bed (cubic feet) = volume of storage x 1.0

SA_{ib} = Surface area of the bottom of the infiltration bed (square feet). Do not count sidewalls in sizing.

f_c = Design infiltration rate of the native limestone subsurface (inches/hour). Designers should always decrease the measured infiltration rate by a factor of 2 during design to approximate clogging over the long-term.

T = Time to fill basin (hours). Assume to be 2 hours (or locally-approved equivalent) for design purposes.

12 = Conversion factor to convert inches/hour to feet/hour.

Important Notes:

- The Practice Volume (P_v) is the storage provided by the practice to meet water quality or runoff reduction goals. See **Chapter 2** for the overall methodology for determining the P_v .
- Sizing Equations Reference the Typical Details in **Figures 6-4** through **6-5**.
- Most of these retrofits will have to still maintain the hydrologic function of the original practice for downstream flood/peak rate control and/or channel protection. This can be accomplished with storage in a wet pond cell (I) and/or detention storage above the normal pool level in the wetland cells, not to exceed 12" (F). The water quality Practice Volume (P_v) for smaller storms can be allocated to the wetland and deep water cells (D + E), forebay (B), and storage in the wet pond cell not needed for larger storm detention (I).

General allocation of the P_v for Stormwater Wetlands is as follows:

- For the Stormwater Wetland Design (**Figure 6-4**), provide up to 25% of P_v in deep pools (E)
- For the Stormwater Pond/Wetland design (**Figure 6-5**), up to 70% of the P_v can be in the wet pond cell (H), as long as flood control and/or channel protection storage can also be provided.
- For both designs, the remainder of P_v should be provided in the High Marsh Zone (D), including storage within any sand or stone layers within the wetland cells.

Design for larger storm detention should follow local criteria and calculation procedures.

Unique Island Factors

There are several factors that must be considered for island applications. Some key factors are noted below:

- Vegetation for the filter bed (multi-cell ponding basin) and stormwater wetlands would ideally be native to the island and commercially available, although meeting both of these criteria can be very difficult. Designers should consult with horticulturalists familiar with local landscapes and vegetation to carefully select the plant palette. There is also a trade-off between plants that will rapidly expand and cover the surface area of the practice and those that will take over and out-compete other desirable species.
- Another aspect to consider for the planting plan is how much and what type of maintenance will be required, and if it is practical that this maintenance will actually be performed by the responsible owner or manager. Sometimes, very simple planting plans (two or three species) that can be maintained through routine activities of the property manager will function better through time than more elaborate designs.
- The soil/compost media for the vegetated filter bed in a multi-cell ponding basin may not be a readily-available material in some jurisdictions, so some flexibility may be required to find the right mixture. The key factors are to have a high fraction of silica-based sand (limestone-based sands can clog the filter) and suitable soil or compost that has a low clay content (< 10%) and low nutrient content (so that the filter does not end up leaching nutrients into the receiving waters).

Key Design Considerations

Multi-cell ponding basins should generally be applied in limestone regions with relatively high infiltration rates. Stormwater wetlands can be used in a wider set of applications, as long as wetland conditions can be maintained. Key considerations for both types of designs include the following:

Maintaining Flood Control and/or Channel Protection Functions of Original Practice.

As stated at the beginning of this chapter, it is crucial to investigate the original design objective and computations when proposing to modify or retrofit an existing stormwater practice. For instance, if the original practice is providing storage to prevent downstream flooding, then maintaining adequate storage to fulfill this objective would be an important design consideration. However, as stated, many practices have ample opportunities to enhance water quality treatment.

Available Space. Multi-cell ponding basins and stormwater wetlands generally require more space than some other practices. However, there is flexibility with designs because the geometry of the different cells can be altered to fit a site, and the cells do not need to be directly adjacent to each other if connected hydraulically in other ways (e.g., an appropriately sized open channel or pipe system). In general, these practices may require a footprint that takes up about 3% of the contributing drainage area, depending on the average depth of the various cells.

Topography. Ideally, the topography for the multi-cell ponding basin or stormwater wetland should be gently sloping. The

concepts are adaptable in that the different cells (e.g., forebay, filter cell, wetland cells) can be terraced down a sloping site.

Available Hydraulic Head. The necessary head for the design is defined by the elevation difference between the forebay (B for both designs) and overflow weir or spillway/outfall (G for both designs). The site should have enough fall to drive stormwater through the system. If a multi-cell ponding basin filter bed (D) includes an underdrain, there must be enough fall for the underdrain to daylight into the infiltration bed.

Water Table. Multi-cell ponding basins should always be separated from the water table to ensure that groundwater does not intersect the filter bed. Mixing can lead to possible groundwater contamination or failure of the system. A minimum separation distance of 2 feet is recommended between the bottom of the excavated filter bed/infiltration bed and the seasonally high ground water table or other impermeable layer. Of course, stormwater wetlands require enough hydrology to maintain wetland conditions, so some water table inputs are anticipated.

Utilities. Interference with underground utilities should also be avoided, particularly water and sewer lines. Local utility design guidance should be consulted in order to determine the horizontal and vertical clearance required between stormwater infrastructure and other dry and wet utility lines.

Soils. The underlying geologic material (e.g., limestone vs. volcanic) is very important for determining the applicability of either a multi-cell ponding basin or stormwater

wetland. For multi-cell ponding basins, soil conditions do not necessarily constrain the use of the practice as long as infiltration rates are adequate in the excavated infiltration bed. However, soils will determine whether an underdrain is needed for the filter bed. Soils with slow percolation rates in Hydrologic Soil Groups (HSG) C or D usually require an underdrain, whereas HSG A or B soils generally do not. If an underdrain is necessary, it must discharge to the downstream infiltration bed. Highly permeable soils, on the other hand, will make it difficult to maintain a healthy permanent pool in stormwater wetlands and an impermeable liner may be necessary. Underlying soils of Hydrologic Soil Group (HSG) C or D should be adequate to maintain a permanent pool. Most HSG A soils and some HSG B soils will require a liner.

For both types of practices, designers should verify soil conditions and permeability by using the on-site permeability or hydraulic conductivity investigation methods outlined in the **Appendix D**.

Contributing Drainage Area (CDA). The maximum recommended drainage area for a multi-cell ponding basin is generally 10 acres. This is somewhat flexible because the filter bed is designed as an off-line system that only receives flow from smaller (water quality) storm events, while larger flows bypass the filter to the infiltration bed (see **Figure 5-2** and **Table 5-2**). For stormwater wetlands, the drainage area must be large enough or have sufficient baseflow inputs to sustain a permanent pool of water. If the only source of wetland hydrology is stormwater runoff, then 20 or more acres of drainage area are typically

needed to maintain constant water elevations. Smaller drainage areas are acceptable if the bottom of the wetland intercepts the groundwater table or if the designer or approving agency is willing to accept periodic wetland drawdown during the dry season. Stormwater wetlands typically have a drainage area of 10 to 25 acres.

Floodplains. Ideally, both types of practices should be constructed outside the limits of the ultimate 100-year floodplain.

Irrigation or Baseflow. The multi-cell ponding basin should not receive baseflow (e.g., groundwater, spring, or small stream flows), irrigation water, chlorinated wash-water or other non-stormwater flows. As stated above, stormwater wetlands may rely on baseflow to maintain water levels, but other non-stormwater flows should be avoided.

Setbacks. To avoid the risk of seepage, do not allow multi-cell ponding basins or stormwater wetlands to be hydraulically connected to structure foundations or pavement. Since multi-cell ponding basins infiltrate water, they should be located a horizontal distance of 100 feet from any water supply well, 50 feet from septic systems, and 5 feet from down-gradient water/sewer utility lines. Other utility lines such as gas, electric, cable and telephone may cross under the practice if they are double-cased.

Side Slopes. Side slopes for a stormwater wetland should generally have gradients of 4H:1V to 5H:1V. Such mild slopes promote better establishment and growth of the wetland vegetation. They also contribute to easier maintenance and a more natural

appearance. Multi-cell ponding basins can have steeper side slopes, but should strive for 3:1 or flatter for the purposes of access, maintenance, and aesthetics.

Landscaping & Planting Plan. The following landscaping/planting plan guidance is provided for the vegetated filter bed of multi-cell ponding basins and stormwater wetlands:

- Landscaping is critical to the performance and function of the practice; therefore, a landscaping/planting plan must be provided (see **Chapter 3**).
- Native plant species should be specified over non-native species when possible.
- For both filter beds (multi-cell ponding basin) and wetland cells (stormwater wetland), vegetation should be selected based on a specified wetness zone. For filter beds, vegetation should be tolerant of both wet and dry conditions, as these areas can be dry for certain periods of time. On the other hand, wetland cells are expected to stay wet, so vegetation will be more of the wetland variety, with the most wet-footed (inundation-tolerant) species in the bottom and other wetland species around the edges of the wetland cell. The emphasis of the planting plan should be to cover the surface area of the filter bed or wetland cell in a short amount of time. Most of the species should be herbaceous, with trees or shrubs around the perimeter, on tree islands, or wedges in a wetland cell.
- Woody vegetation should not be specified at inflow locations.
- Trees should not be planted directly on top of underdrains, if used, and may

best be located along the perimeter of the practice.

Stormwater Wetlands – Depth Zones and Flow Path. Stormwater wetlands should have a variety of depth/inundation zones and a circuitous flow path. This can be achieved by having multiple wetland cells, shallow pools and deep pools, high marsh zones, and other structures to lengthen the flow path, including: 1) Tree peninsulas, high marsh wedges, and/or cobble and sand weirs configured perpendicular to the flow path; and 2) Tree islands that extend above the normal pool formed by sand, soil, commercially-available coconut (coir) fiber logs, or similar material.

Figure 5-7 provides a conceptual diagram and several examples for increasing the flow path through a stormwater wetland. Based on this figure, designers should strive for a flow path ratio of 2:1 (at a minimum) with 3:1 preferred and where possible given site geometry and layout.

Stormwater Wetlands--Water Balance to Maintain Wetland Hydrology. If the hydrology for the Stormwater Wetland is not supplied by groundwater or dry weather flow inputs, a water balance calculation should be performed to assure the deep pools will not go completely dry during the dry season. The calculation should take into account expected inflow from the drainage area during the dry season, dry season evapotranspiration rates, infiltration loss (if any), and a safety margin of maintaining approximately 6 inches of water in the deep pools.

Figure 5-7. Example of creating a circuitous flow path through the wetland cell. (Top) conceptual diagram, (Bottom left) using a high marsh wedge to lengthen the flow path), and (Bottom right) gabion weir.

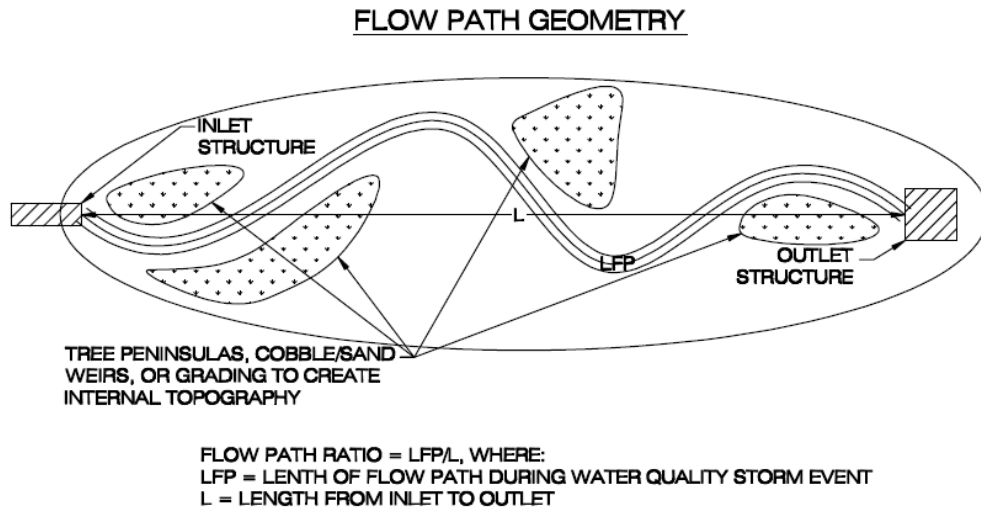

Maintenance. Maintenance is essential for long-term performance, and this is particularly true for vegetation that is part of the design. Maintenance tasks should be driven by annual or semi-annual inspections that evaluate the condition and performance of the practice. **Table 5-4** provides suggested maintenance inspection points, frequencies, and related actions for multi-cell ponding basins and stormwater wetlands.

Table 5-4. Recommended Maintenance Activities for Multi-cell Basins and Stormwater Wetlands

Activity	Schedule
<ul style="list-style-type: none"> • After initial installation (if during the dry season), watering may be needed for plant materials (especially for the filter bed of a multi-cell ponding basin). Water at the frequency necessary to ensure survival. • Pruning and weeding to maintain appearance. • Remove overgrowth of plant materials. • Remove plant debris that seems to be clogging the filter bed or weir structures in a stormwater wetland. • Remove trash and debris. 	As needed
<ul style="list-style-type: none"> • Inspect inflow points for clogging. Remove build-up of sediment and debris. • Inspect overflow structure and remove sediment and debris. • If a minimum coverage of 50% is not achieved in the planted filter bed or stormwater wetland, reinforcement planting will likely be required. Inspect plant materials for survival and replace any dead or severely diseased vegetation. Prune back or remove vegetation that is “taking over” or choking out other plants. 	Semi-annually, at beginning of wet and dry seasons
<ul style="list-style-type: none"> • Inspect and remove any sediment and debris build-up in sedimentation forebay/flow splitter. • Inspect inflow points, filter bed, and/or wetland cells for build-up of sediment and debris. • For multi-cell ponding basins, inspect infiltration bed and backup infiltrators for signs of clogging. • Inspect all slopes and/or concrete structures for signs of erosion or failure. 	Annually, after wet season
<ul style="list-style-type: none"> • Replace riprap if needed in the energy dissipator and/or spillways. • If the filter bed of a multi-cell ponding basin is not draining properly, remove the top layer of soil/compost mix in the filter bed if necessary and replace with clean material. • For filter beds and stormwater wetlands, expect significant changes in plant species composition to occur over time. Inspections should carefully track changes in species distribution over time. Invasive plants should be dealt with as soon as they begin to colonize the filter bed or wetland cell. As a general rule, control of undesirable and/or invasive species should commence when their coverage exceeds more than 15% of the cell area. Although the application of herbicides is not recommended, some types (e.g., Glyphosate) have been used to control invasives with some success. For wetland cells that have been taken over by invasives, extended periods of dewatering can also be tried. 	2 to 3 years
<ul style="list-style-type: none"> • Replace or rehabilitate sedimentation forebay/flow splitter structure, weirs, spillways, pipes, etc. as needed. • Replace or rehabilitate filter bed materials if permanently clogged. • Rehabilitate infiltration bed if permanently clogged. • Clean out underdrains (if any) if clogged with roots or debris. • Completely remove and redo planting plan if completely overgrown. 	Infrequently, as needed

Construction Sequence for Multi-Cell Ponding Basins & Stormwater Wetlands

This section provides a typical construction sequence. However, the actual sequence will depend on site conditions and the location of the system in relation to other areas of the site that are under construction. Also note that the following sequences are more applicable for NEW construction rather than retrofitting. However, some of the steps will apply to retrofits projects, but the sequence and exact steps should be modified based on the retrofit design, condition of the existing practice, extent of excavation, and other factors.

Multi-Cell Ponding Basins

If not used as a temporary sediment basin during construction (see #2 below), multi-cell ponding basins should remain outside the limit of disturbance during construction to prevent soil compaction by heavy equipment.

Step 1: Stabilize Drainage Area. Multi-cell ponding basins should only be constructed after the drainage area to the basin is completely stabilized. If the basin will be used as a sediment trap or basin during the construction/grading phase, then the contractor should ensure that the excavated construction/sediment basin invert is ABOVE (by at least 12") the final design invert of the infiltration bed AND all construction sediment is removed prior to conversion. In addition, the construction notes should clearly spell out conversion details, such as de-watering, removing construction sediment, stabilizing the drainage area, and re-grading to design

dimensions after the original site construction is complete.

Step 2. Excavation. The proposed site should be checked for existing utilities prior to any excavation. Excavators or backhoes working adjacent to the proposed area should excavate the infiltration bed within 12" of the appropriate design depth. Equipment should stay out of the infiltration bed area to prevent compaction.

Step 3. Install the sedimentation basin/flow splitter (or approved pretreatment measures) and the conveyance spillways, but block the low-flow outlet until the filter bed is constructed and stabilized, only allowing runoff to enter the temporary settling basin.

Step 4. Ensure proper timing of installation. The proposed site should be checked for existing utilities prior to any excavation. It may be necessary to install temporary erosion and sediment control measures (e.g., silt fence) around the perimeter of filter bed construction areas to keep sediment from side slopes and the drainage area out of the filter bed area.

The premature installation of vegetated filter bed during construction is the #1 cause of practice failure.

Step 5. Excavate filter bed. Excavators or backhoes working adjacent to the proposed filter bed area should excavate to the appropriate design depth. Equipment should stay out of the filter bed area. It is recommended to "rip" or loosen the underlying native soil to promote better infiltration.

Step 6. Install the underdrain system if included in the design (including clean-outs outfall to infiltration bed). Cover the underdrain layer with needle-punched, non-woven geotextile OR 2-3" of pea gravel or choker stone.

Step 7. Place the approved soil/compost mix, applying in 12-inch lifts until the desired top elevation is achieved. Cover the bed with water to saturate and help settle the soil layer. It may be necessary to wait a few days to check for settlement, and add additional media as needed.

Step 8. Install the plant materials in the filter bed as per approved plans, and irrigate accordingly to ensure survival.

Step 9. Bring filter bed on-line. Once the filter bed is constructed and stabilized (vegetation is growing and healthy), the low-flow outlet from the sedimentation basin/flow splitter may be un-blocked, bringing the filter bed on-line.

Step 10. Clean-out and remove any construction sediment from the infiltration bed location. Excavators or backhoes working adjacent to the proposed infiltration bed shall finish excavating to the design depth, and the backup infiltrators and overflow spillway should be installed. Equipment should stay out of the infiltration bed area to prevent compaction.

Step 11. Conduct final construction inspection, checking inlet, pretreatment, spillways, filter bed, infiltration bed, backup infiltrators, and outlet elevations.

Stormwater Wetlands

The following construction sequence is recommended for installing a stormwater wetland facility and establishing vigorous plant cover.

Step 1: Stabilize Drainage Area.

Stormwater Wetlands should only be constructed after the drainage area to the wetland is completely stabilized. If the proposed wetland site will be used as a sediment trap or basin during the construction phase, the construction notes should clearly indicate that the facility will be de-watered, dredged and re-graded to design dimensions after the original site construction is complete.

Step 2: Assemble construction materials on-site, make sure they meet design specifications, and prepare any staging areas.

Step 3: Clear and strip the project area to the desired sub-grade.

Step 4: Install erosion and sediment controls prior to construction, including temporary dewatering devices, sediment basins, and stormwater diversion practices. All areas surrounding the wetland that are graded or denuded during construction of the wetland are to be planted with turf grass, native plant materials or other approved methods of soil stabilization. During construction, the wetland must be blocked off from the drainage area so that no sediment flows into the wetland areas. In some cases, a phased or staged erosion and sediment control plan may be necessary to divert flow around the stormwater wetland area until installation and stabilization are complete.

Step 5: Excavate the Core Trench for the Embankment and Install the Spillway Pipe, as applicable. Follow standard embankment construction procedures.

Step 6: Install the riser or outflow structure and ensure that the top invert of the overflow weir is constructed level and at the proper design elevation (flashboard risers are strongly recommended).

Step 7: Construct the embankment and any internal berms in 8 to 12-inch lifts and compacted with appropriate equipment.

Step 8: Excavate/grade until the appropriate elevation and desired contours are achieved for the bottom and side slopes of the wetland.

Step 9: Install flow path lengthening features and soil amendments within wetland area. Since some stormwater wetlands are excavated to deep sub-soils, they can lack the nutrients and organic matter needed to support vigorous growth of wetland plants. It is therefore essential to add sand, compost, topsoil or wetland mulch to all depth zones in the wetland. The importance of soil amendments in excavated wetlands cannot be over-emphasized; poor plant survival is likely if soil amendments are not added. Soil amendment depth should be at least 4 inches for shallow wetlands. No machinery should be allowed to traverse over the planting soil during or after construction. Planting soil should be tamped, but it should not be overly compacted. After the planting soil is placed, it should be saturated and allowed to settle for at least one week prior to installation of plant materials.

Step 10: Construct the emergency spillway in cut or structurally stabilized soils.

Step 11: Install outlet pipes, including the downstream rip-rap apron protection.

Step 12: Stabilize exposed soils with erosion control blankets or with cuttings, plugs or seed appropriate for your island's wetland environment. All slopes above the normal pool elevation should be temporarily stabilized. Avoid using invasive species.

Step 13: Finalize the wetland landscaping plan. At this stage the engineer, landscape architect, and wetland expert work jointly to refine the initial wetland planting plan. Several weeks of standing time is needed so that the designer can more precisely ascertain the inundation zones, final grades, and the need for additional soil amendments or plant substitutions.

Step 14: Open the drainage area connection and measure and stake planting depths. Once the final grades are attained, the pond and/or drainage area connection should be opened to allow the wetland cell to fill up to the normal pool elevation. Inundation must occur in stages so that deep pool and high marsh plant materials can be placed effectively and safely. Wetland planting areas should be at least partially inundated during planting to promote plant survivability. The timing of this step is important, in that the wet season may be too wet to control the water level, but extended periods of dry and very hot weather should also be avoided.

At this time, it may be necessary to modify the plan to reflect altered depths or a change in the availability of wetland plant

stock, seed, or harvested plants. Surveyed planting zones should be marked on the as-built or design plan, and their locations should also be identified in the field, using stakes or flags.

Step 15: Propagate the stormwater wetland. Three techniques are used in combination to propagate the emergent community over the wetland bed:

1. *Initial Planting of Container-Grown Wetland Plant Stock.* If possible, the plants should be ordered several months in advance to ensure the availability and on-time delivery of desired species.
2. *Broadcasting Wetland Seed Mixes.* The wetland plants can be established by broadcasting wetland seed mixes to establish diverse emergent wetlands. Wetland seed mixes are an option for zones that are 3 inches below the normal pool elevation or higher. Hand broadcasting or hydroseeding can be used to spread seed, depending on the size of the wetland cell.
3. *Allowing “Volunteer” Wetland Plants to Establish on Their Own.* The remaining areas of the Stormwater Wetland will eventually (within a number of months) be colonized by volunteer species from upstream or adjacent areas.

Step 16: Install protection from birds/predation to protect newly planted vegetation. This is particularly critical for newly established emergent and herbaceous plants, as predation by some bird species or other wildlife can quickly decimate wetland vegetation. This protection can consist of netting, webbing, or string installed in a crisscross pattern

over the surface area of the wetland, above the level of the emergent plants.

Step 17: Plant the wetland fringe and buffer area. This zone generally extends from 1 to 3 feet above the normal pool elevation. Consequently, plants in this zone are infrequently inundated, and must be able to tolerate both wet and dry periods.

Avoiding Common Pitfalls

Table 5-5 lists some common pitfalls with multi-cell ponding basins and stormwater wetlands, and also suggests ways to avoid the pitfalls during design, plan review, installation, and while conducting maintenance activities.

Table 5-5. Tips to Avoiding Common Pitfalls

What goes wrong	How to avoid/solve it		
	Design and Review Tips	Installation Tips	Maintenance Tips
1. Erosion at inlets, weirs, spillways	Ensure that expected wet season flow rates are used to size these conveyances and that adequate details are provided for these components.	<ul style="list-style-type: none"> • Make sure that all weir sections and inlets are level perpendicular to the flow path. • Ensure lining, rip-rap, or fabric is installed correctly. 	<ul style="list-style-type: none"> • Repair areas of erosion when they are detected. • Promptly clear obstructions and debris. • Add matting or rock if design is not adequate to create non-erosive conditions.
2. Water level is not stable in stormwater wetland cells	Conduct a simple water balance calculation and soil investigation as part of the design. If soils are too permeable, a liner can be specified. Include flashboards or adjustable valves in the design so that water levels can be adjusted as part of operations.	Once grading and facility construction is complete, let the facility fill and check the water level. As such, adjustments can be made to the planting plan based on actual inundation zones.	Check water levels in wet and dry seasons. Move or replace plants based on actual inundation zones.
3. Plants go wild: one or several or invasives take over	<ul style="list-style-type: none"> • For multi-cell ponding basin filter cell, keep the planting plan simple and include a maintenance plan that specifies what plants are supposed to be there and how to control invasives. Consult a qualified horticulturalist for the initial plant selection. • For stormwater wetlands, include various depth zones and micro-topographic features to promote a more diverse plant community. Ensure that the original planting plan includes a maintenance plan, diagrams, and photos to indicate what vegetation is intended. • For both, avoid too many species that are known as aggressive colonizers. 	Make sure seed sources from adjacent areas (especially areas that are already overrun with invasives) are controlled.	<ul style="list-style-type: none"> • Try to control invasives before they spread to more than 15% of the surface area of the practice or cell. • Cut back or eliminate species that are getting too large and choking out other desirable plants. • Try effective control techniques, such as mechanical removal, water-safe <i>Glyphosate</i> products, and/or extended periods of dewatering where invasives have taken over.
4. Filter Cell clogging	Ensure proper soil/compost mix is specified (see Chapter 3). Make sure a non-woven geotextile with an adequate flow rate is specified under the soil/compost layer (especially if an underdrain is used). 2 to 3 inches of pea gravel can be substituted. Do NOT use regular filter fabric because it is likely to clog. Provide proper construction sequencing notes so that soil/compost is not installed until the drainage area is stabilized.	<ul style="list-style-type: none"> • Install soil/compost after proper site stabilization. • Properly install the specified non-woven geotextile. • Avoid compacting the soil/compost layer by not running equipment over it (work from perimeter) and install in lifts. 	<ul style="list-style-type: none"> • Problem may be in top 2 to 3 inches. Scrape off and replace with clean material, mostly silica-based sand. • If this is not adequate, it may be necessary to auger several holes down through the soil/compost and punch through the geotextile (backfill holes with sand or gravel). • In some cases, replace the soil/compost layer.

References

- Bearden, B. and Horsley Witten Group, Inc. 2010. Palau Stormwater Management Manual.
- Center for Watershed Protection. 2006. Design Guidelines for Stormwater Treatment Practices To Protect Water Quality in Maui County, Hawaii.
- Center for Watershed Protection and Horsley Witten Group, Inc. 2010. Island Stormwater Practice Design Specifications. <http://www.deq.gov.mp/artdoc/Sec6art55ID672.pdf>
- City and County of Honolulu Hawaii. 2012. Green Infrastructure for Homeowners. http://www.cleanwaterhonolulu.com/storm/learning_center/Green%20Infrastructure%20for%20Homeowners-FINAL.pdf
- City and County of Honolulu, Department of Planning and Permitting. 2012. Storm Water BMP Guide. [http://www.honoluludpp.org/Portals/0/SiteDevelopmentDivision/DPP%20Storm%20Water%20BMP%20Guide%20\(Dec-2012\).pdf](http://www.honoluludpp.org/Portals/0/SiteDevelopmentDivision/DPP%20Storm%20Water%20BMP%20Guide%20(Dec-2012).pdf)
- Commission on Water Resource Management, State of Hawaii. 2008. A Handbook for Stormwater Reclamation and Reuse Best Management Practices in Hawaii. http://www.state.hi.us/dlnr/cwrm/planning/hsrar_handbook.pdf
- Department of Public Works. 2010. Guam Transportation Stormwater Drainage Manual. <http://www.guamtransportationprogram.com/docs/about-the-program/design-resources/stormwater-drainage-manual.pdf>
- Devine B. and S. Coldren. 2011. Cistern Water Quality Testing & Results in Coral Bay, St. John, US Virgin Islands. The Coral Bay Community Council CARE Project. 19 pp. <http://www.coralbaycommunitycouncil.org/CBCC-Cistern-Water-Quality-Report-3-25-11b-final.pdf>
- Horsley Witten Group, Inc. 2006. CNMI and Guam Stormwater Management Manual. Volumes I and II: <http://www.deq.gov.mp/article.asp?seclD=6&artID=55>
- Kaufman, A., Cox, L.J., Tomoaki, M., Easterday, D., Collins, B. 2007. The Potential for Green Roofs in Hawai'i. <http://www.ctahr.hawaii.edu/oc/freepubs/pdf/RM-15.pdf>
- Huio Ko'olaupoko. 2013. Hawai'i Residential Rain Garden Manual. <http://www.huihawaii.org/raingarden.html>
- Heitz, L., N. Habana, and J. Raza. 2001. Designing Your Rainwater Catchment and Storage System. Water Information Bulletin No.3. Water and Environmental Research Institute of the Western Pacific, University of Guam.
- Hogg, R., 2003. Construction of a Water Storage Tank for Micronesia. Water Information Bulletin No.4. Water and Environmental Research Institute of the Western Pacific, University of Guam.

Macomber , P.. 2010. Guidelines on Rainwater Catchment Systems for Hawai'i Revised edition.
<http://www.ctahr.hawaii.edu/oc/freepubs/pdf/rm-12.pdf>

State of Hawaii, Department of Transportation, Highways Division. 2007. Storm Water Permanent Best Practices Manual. <http://stormwaterhawaii.com/pdfs/PermanentManual.pdf>

State of Hawaii, Office of Planning. 2006. Low Impact Development, A Practitioner's Guide.
http://files.hawaii.gov/dbedt/op/czm/initiative/lid/lid_guide_2006.pdf

USDA-NRCS. 2010. Pacific Islands Area Vegetative Guide. Technical Note-7.
http://www.nrcs.usda.gov/Internet/FSE_PLANTMATERIALS/publications/hipmstn9761.pdf

USDA-NRCS. 2008. Rainfall Frequency and Design Rainfall Distribution for Selected Pacific Islands.
http://www.nrcs.usda.gov/Internet/FSE_DOCUMENTS/nrcs142p2_036808.pdf

Appendix A

Island Rainfall Reference Guide

American Samoa
Commonwealth of the Northern Mariana Islands
Guam
Hawaii
Puerto Rico
US Virgin Islands
Other Selected Pacific Islands

Daily Rainfall Analysis Procedures

Introduction

This reference guide presents the most recent rainfall information available from public sources for the Pacific and Caribbean Islands that are the focus of this stormwater guide. The purpose of this appendix is to compile average rainfall depths (in inches) associated with standard recurrence intervals over a 24-hr duration (e.g., 1-yr, 2-yr, 10-yr, 100-yr storms), as well as depths associated with event percentiles (e.g., 80th, 90th, and 95th storms) used as treatment criteria in many stormwater design manuals. This precipitation data is derived either from summary tables from existing documents, or from available precipitation datasets where such information is currently absent or considered “outdated.”

Primary sources of additional information include:

- NOAA Atlas 14 and the National Weather Service Precipitation Data Frequency Server (PFDS) available online at <http://hdsc.nws.noaa.gov/hdsc/pfds/>
- Environmental Verification and Analysis Center: Pacific Rainfall Database (PACRAIN) dataset available online at <http://pacrain.evac.ou.edu/>
- USGS Pacific Islands Water Science Center: online database and paper records available online at http://hi.water.usgs.gov/studies/project_waterdata.htm
- Oregon State University Climate Center: annual precipitation for the climatological period of 1971-2000 (www.prism.oregonstate.edu/products/pacisl.phtml).

In the USVI, for example, a recent analysis by Cadmus (2011) is cited to summarize the 90th and 95th percentile storm depths, but also provided are average rainfall depth maps from NOAA Atlas 14 for various design storms that are based on an updated rainfall record than what is currently documented in the 2002 USVI Environmental Handbook. For Guam and CNMI, the design storm criteria as cited in the 2009 CNMI and Guam Stormwater Design Manual is listed, as well as additional information from NOAA and PACRAIN, where available. Extended periods of record can better account for changes in climate, however, the caveat here is that NOAA or PACRAIN data has not gone through the rigorous analysis that the University of Guam, for example, conducted when generating rainfall data for the CNMI and Guam stormwater manual. Therefore, users should be careful how they apply the information provided here.

This Appendix is organized by each state and US territory, followed by other select, non-US jurisdictional Pacific Islands (e.g., Republic of Palau, FSM). For each island, we provide a brief summary of existing stormwater requirements, annual rainfall statistics in tabular and map format, as well as rain fall station maps, where available. The following subsections are included:

- Stormwater Design Standards—basic information on what rainfall depths and volumes are currently required.
- Annual Precipitation—generally presented in map format.
- Rainfall Frequency Maps—excerpts from NOAA Atlas 14 maps of 24-hr storm durations at 1-yr, 2-yr, 10-yr, 25-yr, and 100-yr recurrence intervals.
- Rainfall Analyses—includes a tabular summary of measured events at select gauging stations (e.g., rainfall depths over select recurrence intervals, percentile storm depths, and frequency spectrum graphs) and station maps.

American Samoa

Stormwater Design Standards

American Samoa does not currently designate a design storm or runoff depth that must be used to size and design post-construction stormwater BMPs for water quality, recharge, or other management criteria.

Annual Precipitation

The mean annual precipitation map of the main island of Tutuila and two associated islands is derived from Oregon State University Climate Center (2007) using partially gridded annual precipitation for the climatological period of 1971-2000. (www.prism.oregonstate.edu/products/pacisl.phtml). Average monthly data is also available.

Mean Annual Precipitation

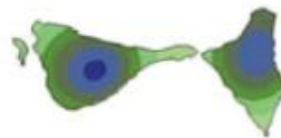
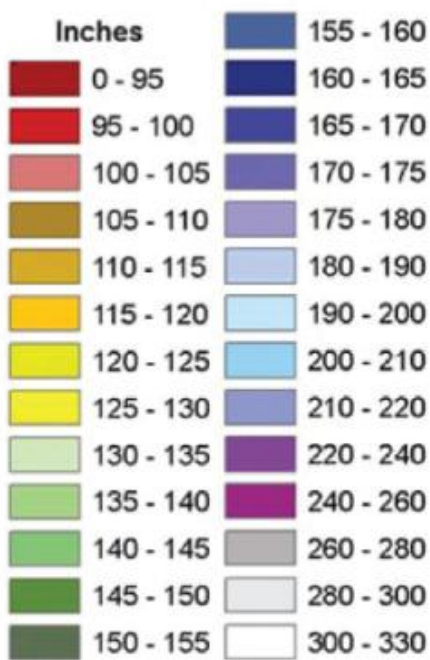

Ofu & Olosega

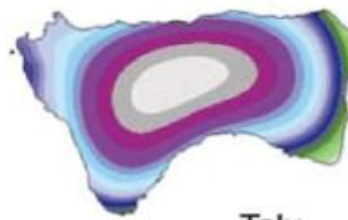

Ta'u

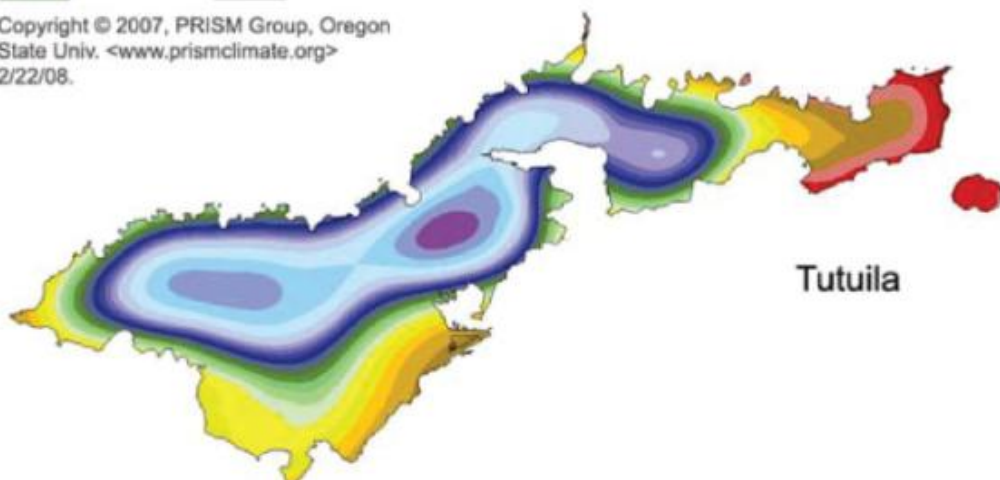

Tutuila

Copyright © 2007, PRISM Group, Oregon State Univ. <www.prismclimate.org> 2/22/08.

Rainfall Frequency Maps

The following excerpts from NOAA Atlas 14, Vol. 5, Version 3, 2011 (online: http://hdsc.nws.noaa.gov/hdsc/pfds/pfds_maps.html) show average rainfall depths for selected recurrence intervals over a 24-hour duration for the main island of Tutuila between 1956-2008.

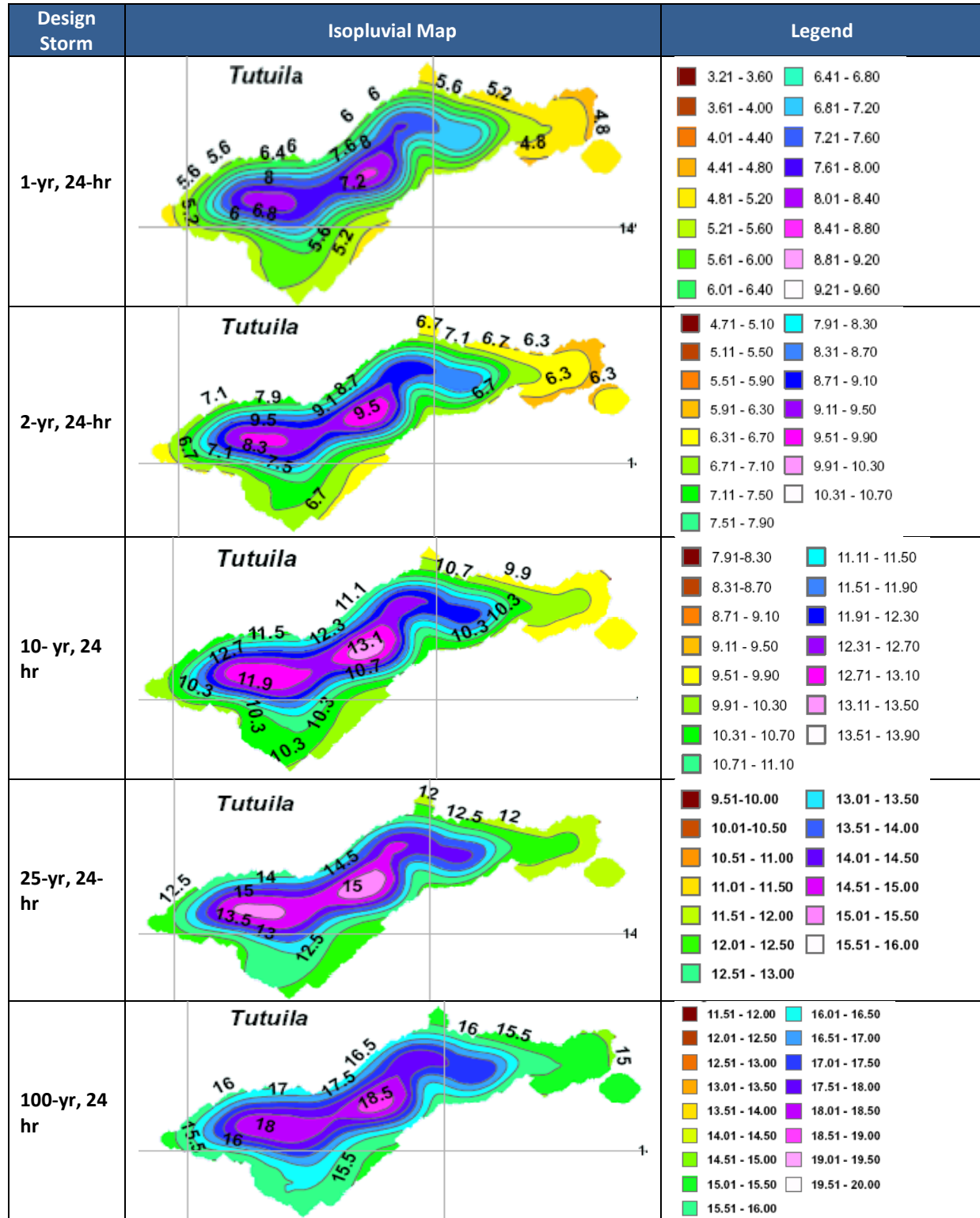

Rainfall Analyses

Table below summarizes data from two sources: local data supplied by Alex Messina from San Diego State University in 2013 and NOAA Atlas 14 PFDS (http://hdsc.nws.noaa.gov/hdsc/pfds/pfds_maps.html) for selected rain gauging stations.

Site	# Rain Events ¹	Average Rain Depth (inches)					
		Local Data		From NOAA Atlas 14			
		90th Percentile	95th Percentile	1-yr, 24-hr	10-yr, 24-hr	25-yr, 24-hr	100-yr, 24-hr
Fagaitua	1912	1.60	2.35				
Faga'alu Res				8.08 (6.04-10.5)	13.0 (9.59-16.9)	15.0 (11.0-19.8)	18.4 (13.2-24.5)
Satala	2186	1.85	2.64				
Pioa-Afono	2438	2.25	3.21	7.05 (5.26-9.15)	11.9 (8.81-15.6)	14.0 (10.3-18.5)	17.3 (12.4-23.2)
Vaipito Res	2577	2.00	2.77	7.94 (5.93-10.3)	12.8 (9.47-16.8)	14.9 (10.9-19.6)	18.2 (13.1-24.4)
Aunuu	682	1.40	2.37				
Vaipito Div	4459	1.90	2.59	7.60 (5.96-9.47)	12.5 (9.69-15.7)	14.6 (11.2-18.4)	17.9 (13.5-22.9)
Malaeimi-Mapusaga	790	3.11	4.32	6.80 (5.08-8.83)	11.7 (8.64-15.3)	13.8 (10.1-18.1)	17.1 (12.3-22.8)
Aasufou	1222	2.36	3.43	8.18 (6.21-10.5)	13.0 (9.81-16.8)	15.1 (11.3-19.7)	18.4 (13.5-24.3)
Pago Pago Airport	657	1.55	2.30	5.27 (4.38-6.23)	10.1 (8.34-12.1)	12.2 (9.96-14.7)	15.5 (12.4-18.9)

The example rainfall frequency spectrum graph shown below was generated based on rainfall data for the Fagaitua station. This graph allows you to determine the potential management volumes for different event percentiles. While American Samoa does not currently have a specified management target, management of the 90th percentile storm for water quality treatment is common in the US for sizing stormwater facilities. This chart shows that there is 1.6 inches of rainfall associated with the 90th percentile around the Fagaitua station. If you were designing a bioretention facility, for example, and wanted to size it to meet a water quality volume target of the 90th percentile (managing runoff from 90% of annual storm events), you would have to size the practice to handle the first 1.6 inches of rainfall on your site.

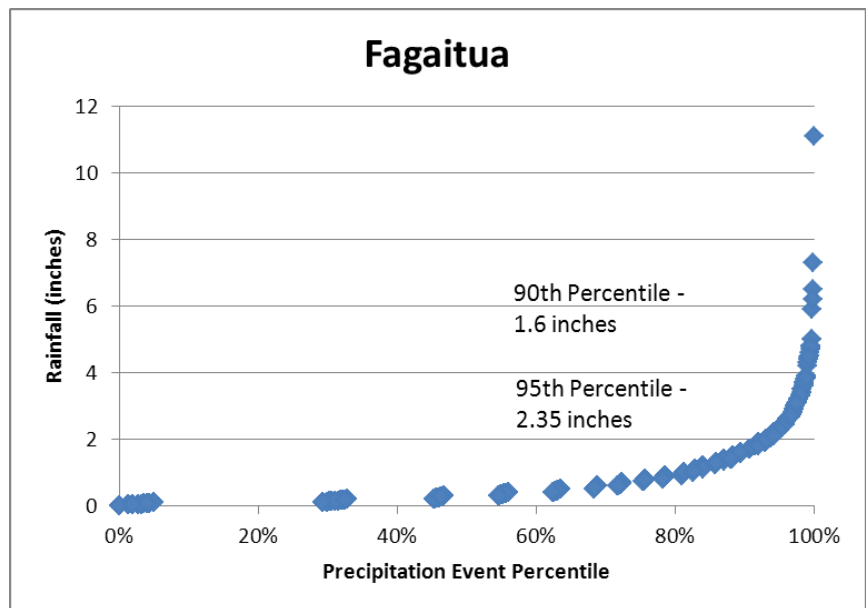

The following station map is provided from the NOAA PFDS website at http://hdsc.nws.noaa.gov/hdsc/pfds/pfds_map_pi.html. It shows the locations of some (if not all) of the referenced gauging stations.



Evapotranspiration Rates

USGS (2005) also recently developed a mean annual potential evapotranspiration rate map for Tutuila using climatological data from 1999-2005.

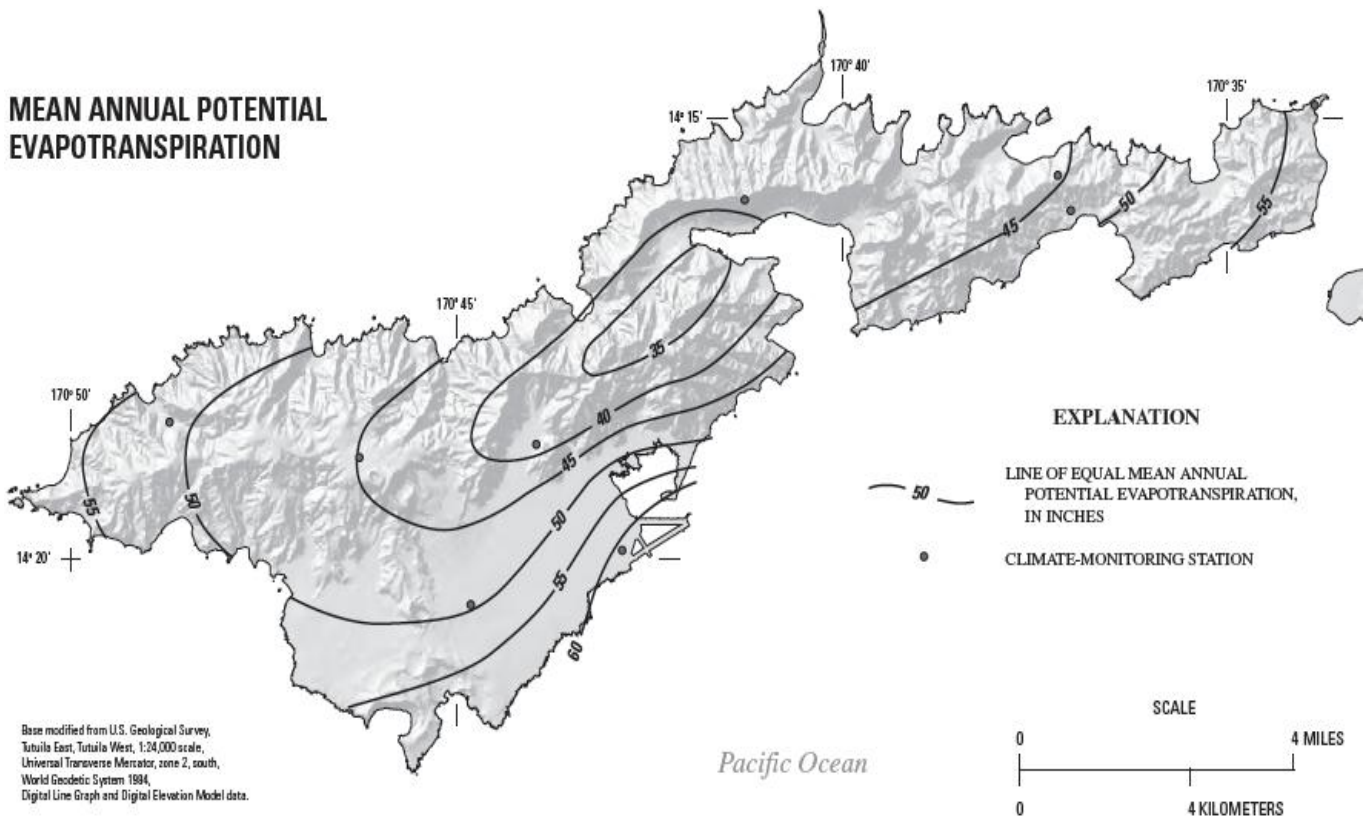

Commonwealth of the Northern Mariana Islands

Stormwater Standards

The 2006 CNMI and Guam Stormwater Manual established required sizing criteria for water quality, channel protection, recharge, and overbank flood protection as a function of geology, land use, and resource quality (see table below).

Criteria	Requirement										
Recharge (Re_v)	<p><u>Limestone-Dominated Regions:</u></p> <p>$Re_v = (1.5 \text{ in}) (A) (I)/12$ expressed in acre-feet where: I = Impervious area percentage of site area (decimal) A = Site area (acres)</p> <p><u>Volcanic-Dominated Regions:</u></p> <p>$Re_v = (F) (A) (I)/12$ expressed in acre-feet where: I = Impervious area percentage of site area (decimal) A = Site area (acres)</p> <table border="0"> <thead> <tr> <th>Hydrologic Soil Group</th> <th>Annual Recharge Volume Factor (F)</th> </tr> </thead> <tbody> <tr> <td>A</td> <td>0.80 inches</td> </tr> <tr> <td>B</td> <td>0.50 inches</td> </tr> <tr> <td>C</td> <td>0.20 inches</td> </tr> <tr> <td>D</td> <td>0.10 inches</td> </tr> </tbody> </table> <p>Note: Stormwater runoff from hotspots should not infiltrate into groundwater without appropriate pretreatment equivalent to 100% of the water quality volume</p>	Hydrologic Soil Group	Annual Recharge Volume Factor (F)	A	0.80 inches	B	0.50 inches	C	0.20 inches	D	0.10 inches
Hydrologic Soil Group	Annual Recharge Volume Factor (F)										
A	0.80 inches										
B	0.50 inches										
C	0.20 inches										
D	0.10 inches										
Water Quality (WQ_v)	<p><u>90% Rule (Discharge to High Quality Waters & Hotspot Land Uses):</u></p> <p>$WQ_v = [(P)(A)(I)] / 12$ expressed in acre-feet where: P = 1.5 inches¹ I = Impervious area percentage of site area (decimal) A = Site area (acres)</p> <p><u>80% Rule (Discharge to Moderate Quality Waters):</u></p> <p>$WQ_v = [(P)(A)(I)] / 12$ expressed in acre-feet where: P = 0.8 inches¹ I = Impervious area percentage of site area (decimal) A = Site area (acres)</p> <p>Note: Minimum $WQ_v = 0.0167\text{ft}^*(A)$ in acre-feet (or 0.2 watershed inches)</p>										
Channel Protection (Cp_v)	$Cp_v = 24$ hours extended detention of post-developed 1-year, 24-hour rainfall event.										
Overbank Flood Control (Q_{p-25})	Control the peak discharge from the 25-year storm to 25-year pre-development rates.										

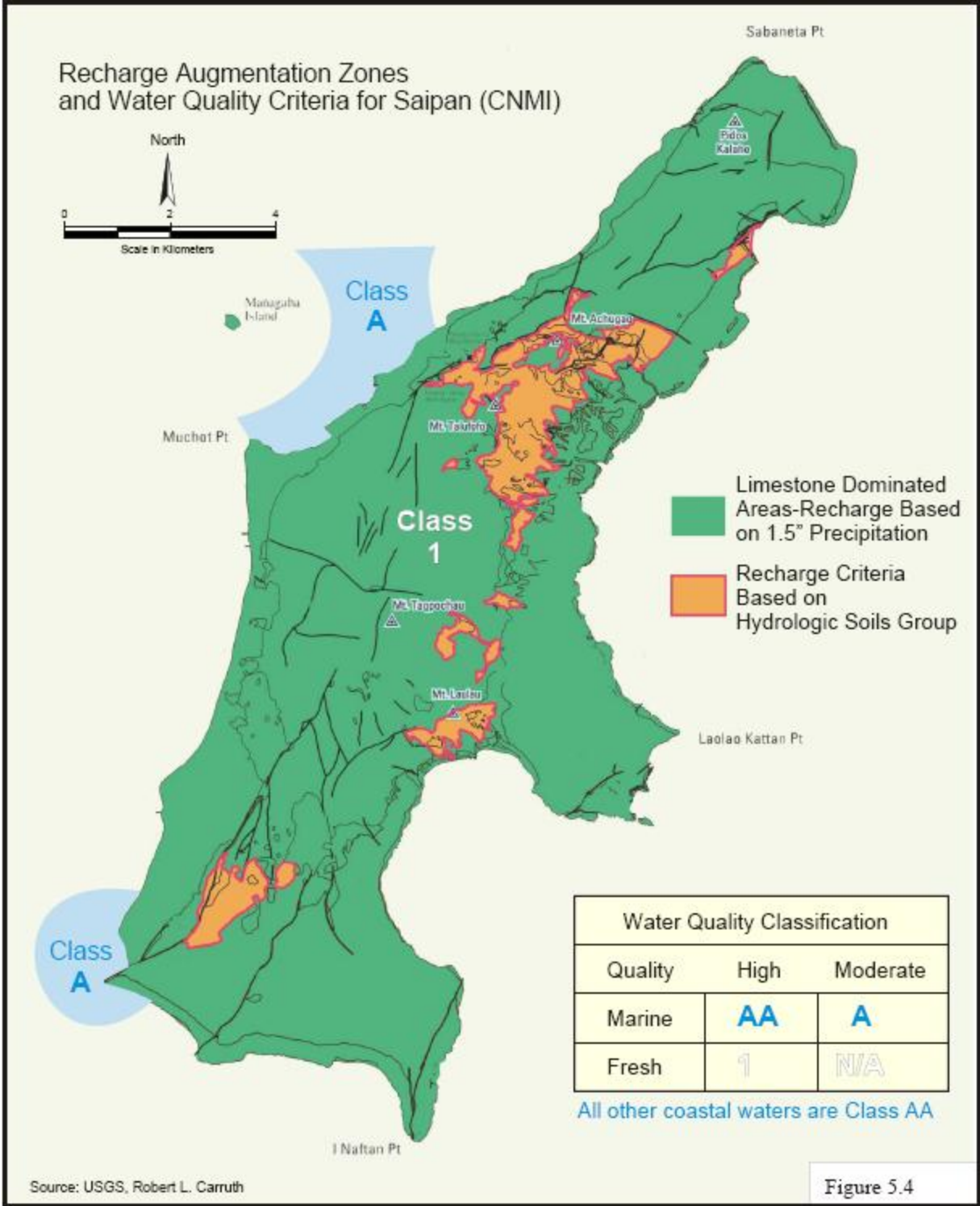
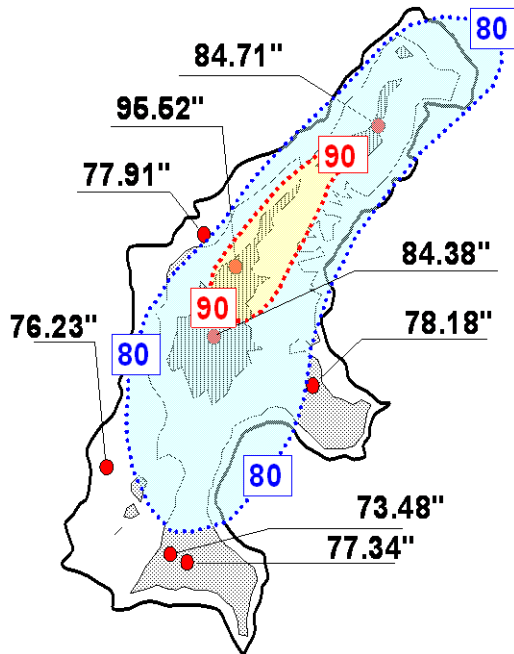

Figure 5.4

Annual Precipitation

Generally, Saipan receives approximately 80 inches of rain per year, with a large percentage of the annual rainfall contributed by tropical storms. The annual rainfall values shown below are presented in the 2006 CNMI and Guam Stormwater Manual derived by Lander, 2004 (unpublished).



Location	Average Annual Rainfall (inches)
Saipan (CNMI)	
Capitol Hill	95
Marpi	85
Mt. Tagpochau	85
Saipan Int'l Airport	75
Susupe	75
Tinian (CNMI)	80
Rota (CNMI)	80

The mean annual precipitation map below of the islands of CNMI (not to scale) is derived from Oregon State University Climate Center (2007) using partially gridded annual precipitation for the climatological period of 1971-2000. (www.prism.oregonstate.edu/products/pacisl.phtml).

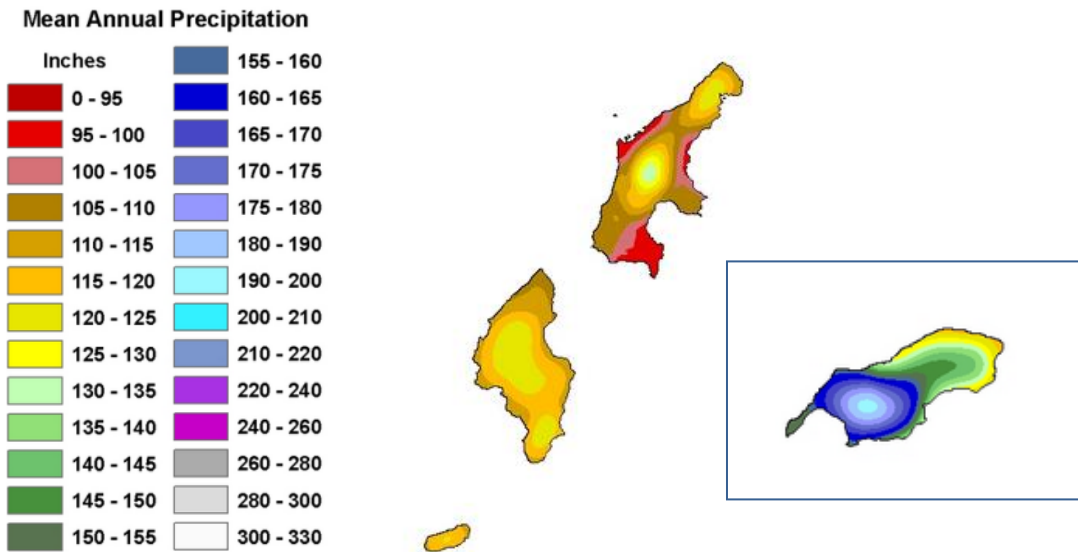

Rainfall Frequency Maps

The following map excerpts from NOAA Atlas 14, Vol. 5, Version 3, 2011 (online: http://hdsc.nws.noaa.gov/hdsc/pfds/pfds_maps.html) show average rainfall depths for selected recurrence intervals over a 24-hour duration for Saipan, Rota, and Tinian (not to scale). The period of record used for Saipan appears to be 1980-2007.

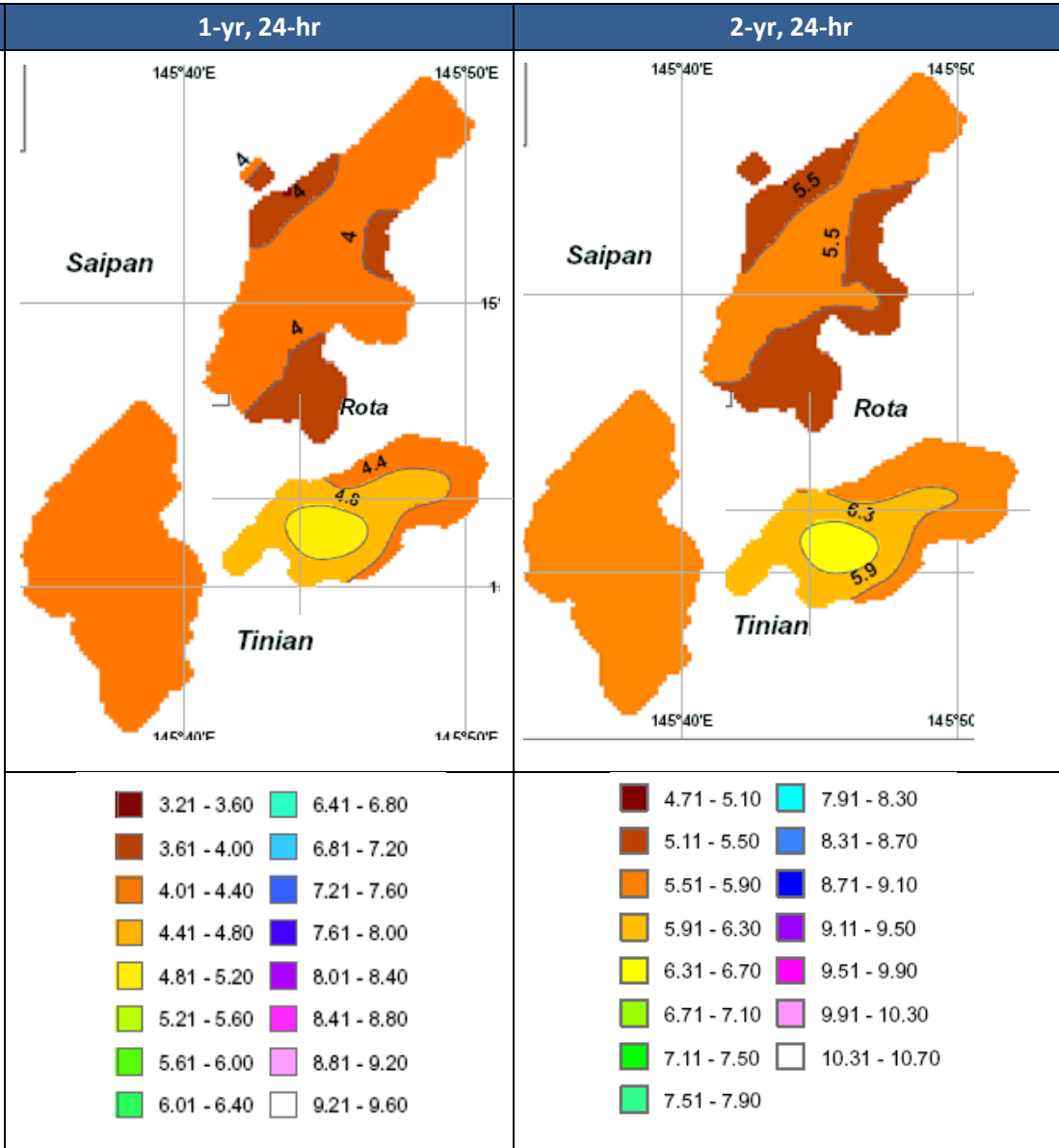

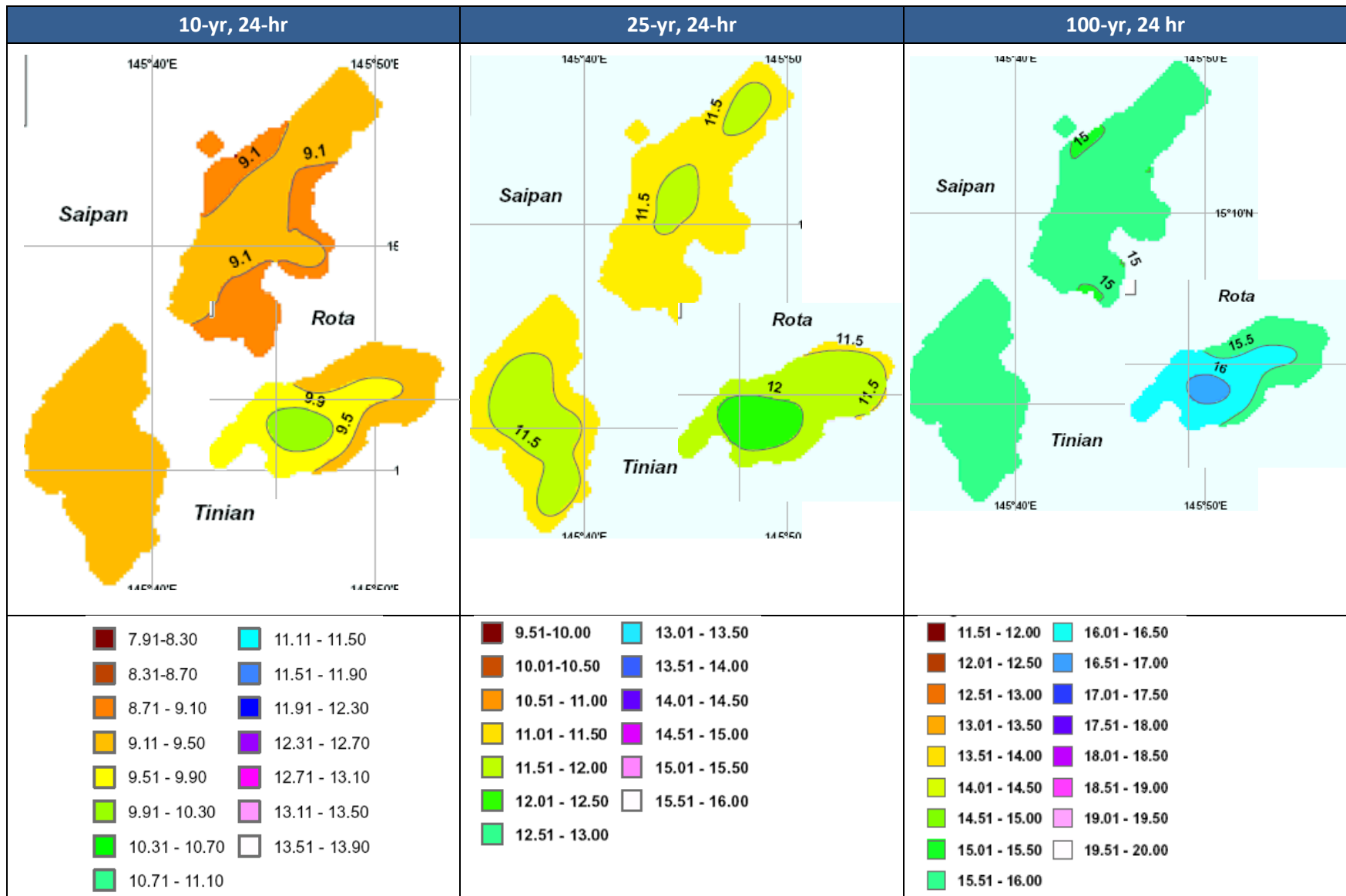

Rainfall Analysis

Rainfall data on Saipan is piecemeal, there is confusion regarding the location of some rain gauges, and no long-term record is available for any single location (Lander, 2004). The rainfall analysis used for the 2006 CNMI and Guam Stormwater Manual was constructed by WERI in 2004 from a 46-year record on Saipan and from similarities to the properties of rainfall from a long-term continuous meteorological observatory on northern Guam. Thus, for locations other than northern Guam, the Manual requires designers to apply an adjustment factor when calculating the design storm events for 1-yr storms and greater. The table below shows the rainfall depths for common recurrence intervals in Northern Guam with an adjustment factor map on the right that shows which factor to use in CNMI based on your site location. To calculate the rainfall depth for the 1-yr storm for a project in Tinian, for example, multiply 3.5 inches x 0.8 factor, for an adjusted depth of 2.8 inches.

24-hour Rainfall Events for Northern Guam and CNMI adjustment Factors (adapted from Lander, 2004)

Recurrence Interval (years)	Exceedance Frequency (%)	Average Rainfall (inches)	<p style="text-align: center;">Adjustment Factors</p>
1	100	3.5	
2	50	7.0	
10	10	10.0	
25	4	20.0	
50	2	27.0	

You may notice that these values differ from those generated from NOAA Atlas 14 PFDS (http://hdsc.nws.noaa.gov/hdsc/pfds/pfds_maps.html) for return intervals at selected rain gauging stations. For example, the estimated average depth for the 1-yr storm on Tinian based on the analysis in the 2006 Manual was 2.8 inches. Using NOAA Atlas 14, it is closer to 4.25 inches (ranging from 3.19 – 5.49 inches). For the 25-yr event, the 2006 Manual lists 16 inches in Tinian, whereas the NOAA Atlas 14 lists an average value of 11.5 inches (ranges from 11-12 inches). The NOAA Atlas period of record for Saipan appears to be 1980-2007, but it is unclear if this data is “better” than what was generated by WERI, or if the extended period of record more accurately reflects changing climate patterns. Regardless, the Manual establishes minimum target volumes, but managing for a higher volume may be the more conservative approach, which we would recommend where practical.

Site	# Rain Events ¹	Average Rain Depth (inches)					
		PACRAIN		From NOAA PFDS			
		90th Percentile Event ¹	95th Percentile Event ¹	1-yr, 24-hr	10-yr, 24-hr	25-yr, 24-hr	100-yr, 24-hr
Garapan, Saipan				4.29 (3.20-5.57)	9.34 (6.91-12.2)	11.6 (8.51-15.3)	15.4 (11.0-20.5)
Saipan Intl Airport, Saipan	5441	0.83	1.31	3.98 (3.05-5.05)	9.03 (6.87-11.5)	11.3 (8.51-14.5)	15.0 (11.1-19.6)
Rota AP, CNMI				4.50 (3.40-5.79)	9.55 (7.14-12.4)	11.8 (8.76-15.4)	15.6 (11.3-20.6)
Tinian, CNMI	5318	0.83	1.4	4.25 (3.19-5.49)	9.30 (6.92-12.1)	11.6 (8.53-15.2)	15.3 (11.1-20.4)

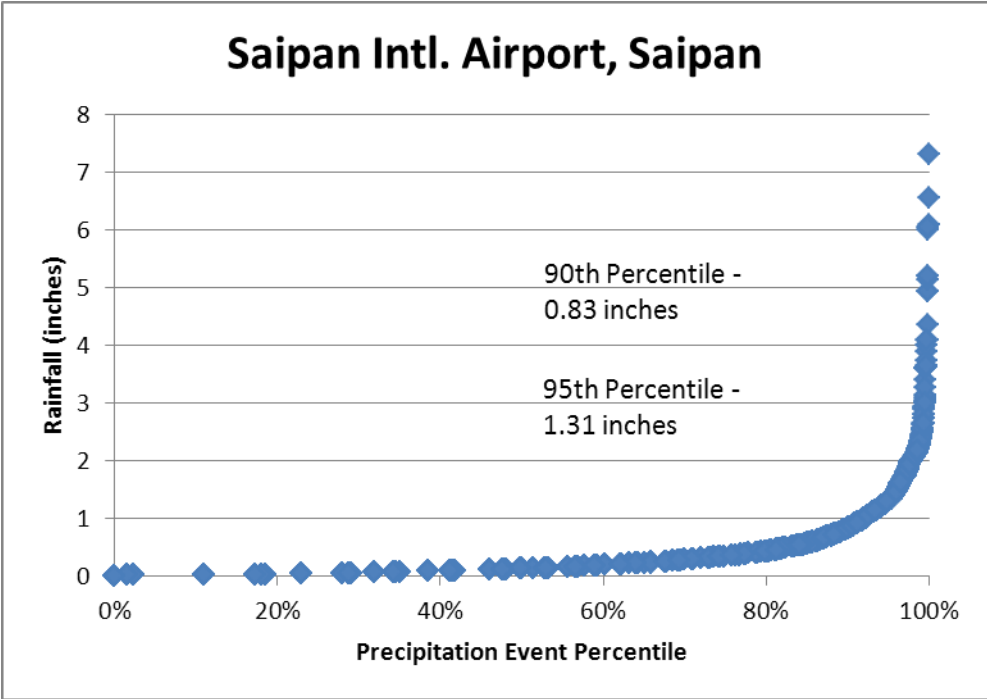

The following station map is provided from the NOAA PFDS website at http://hdsc.nws.noaa.gov/hdsc/pfds/pfds_map_pi.html. It shows the locations of some (if not all) of the referenced gauging stations.

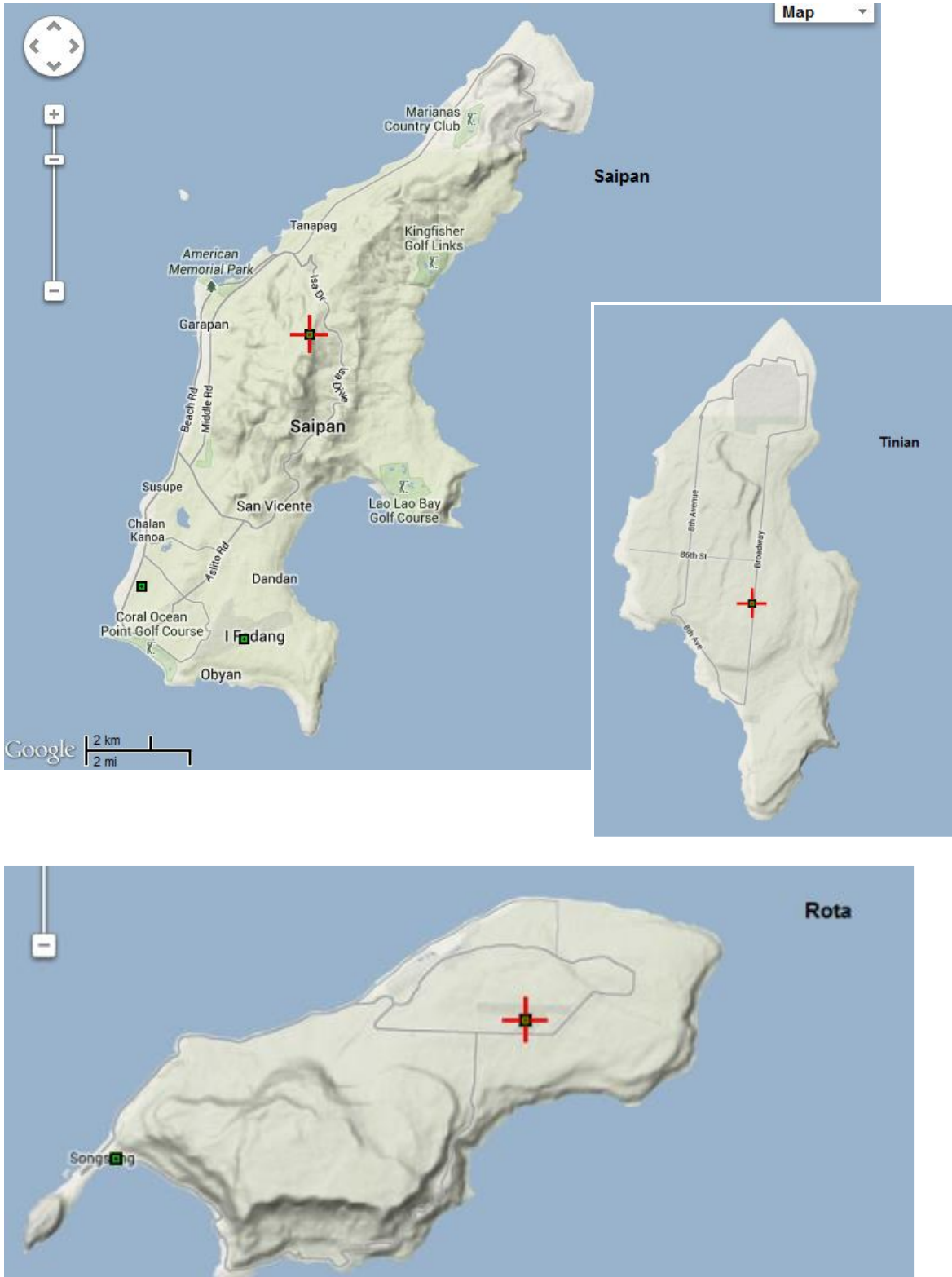

Guam

Stormwater Standards

In January 2012, the 2006 *CNMI and Guam Stormwater Management Criteria* was adopted for use in all non-transportation construction projects and construction projects on private property. The *Guam Transportation Stormwater Drainage Manual* prepared by the DPW was adopted for use in all local and federal-aid public transportation projects, including highway and roadway projects. The 2006 CNMI and Guam Stormwater Manual established required sizing criteria for water quality, channel protection, recharge, and overbank flood protection as a function of geology, land use, and resource quality (see table below).

Criteria	Requirement										
Recharge (Re_v)	<p><u>Limestone-Dominated Regions:</u></p> <p>$Re_v = (1.5 \text{ in}) (A) (I)/12$ expressed in acre-feet where: I = Impervious area percentage of site area (decimal) A = Site area (acres)</p> <p><u>Volcanic-Dominated Regions:</u></p> <p>$Re_v = (F) (A) (I)/12$ expressed in acre-feet where: I = Impervious area percentage of site area (decimal) A = Site area (acres)</p> <table> <thead> <tr> <th>Hydrologic Soil Group</th> <th>Annual Recharge Volume Factor (F)</th> </tr> </thead> <tbody> <tr> <td>A</td> <td>0.80 inches</td> </tr> <tr> <td>B</td> <td>0.50 inches</td> </tr> <tr> <td>C</td> <td>0.20 inches</td> </tr> <tr> <td>D</td> <td>0.10 inches</td> </tr> </tbody> </table> <p>Note: Stormwater runoff from hotspots should not infiltrate into groundwater without appropriate pretreatment equivalent to 100% of the water quality volume</p>	Hydrologic Soil Group	Annual Recharge Volume Factor (F)	A	0.80 inches	B	0.50 inches	C	0.20 inches	D	0.10 inches
Hydrologic Soil Group	Annual Recharge Volume Factor (F)										
A	0.80 inches										
B	0.50 inches										
C	0.20 inches										
D	0.10 inches										
Water Quality (WQ_v)	<p><u>90% Rule (Discharge to High Quality Waters & Hotspot Land Uses):</u></p> <p>$WQ_v = [(P)(A)(I)] / 12$ expressed in acre-feet where: P = 1.5 inches¹ I = Impervious area percentage of site area (decimal) A = Site area (acres)</p> <p><u>80% Rule (Discharge to Moderate Quality Waters):</u></p> <p>$WQ_v = [(P)(A)(I)] / 12$ expressed in acre-feet where: P = 0.8 inches¹ I = Impervious area percentage of site area (decimal) A = Site area (acres)</p> <p>Note: Minimum $WQ_v = 0.0167\text{ft}^*(A)$ in acre-feet (or 0.2 watershed inches)</p>										
Channel Protection (Cp_v)	$Cp_v = 24$ hours extended detention of post-developed 1-year, 24-hour rainfall event.										
Overbank Flood Control (Q_{p-25})	Control the peak discharge from the 25-year storm to 25-year pre-development rates.										

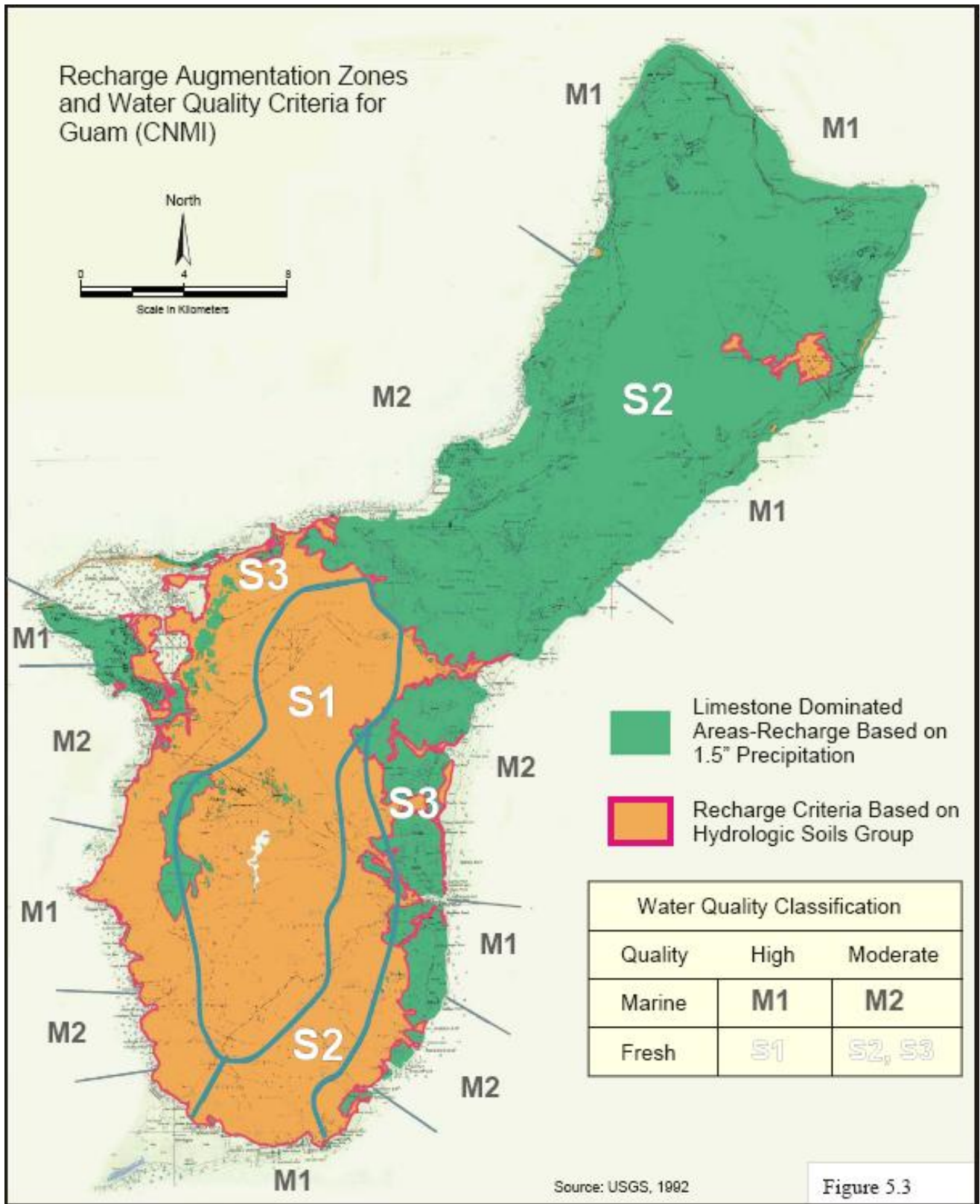

Annual Precipitation

Rainfall data has been collected on Guam since 1906 (CDM, 1982). The mean annual rainfall ranges from slightly more than 100 inches at the northern tip of the island and in higher mountainous areas of the south to approximately 85 to 95 inches along the central and southern coasts (Duenas & Associates, 1996). The annual rainfall distribution map/table shown below on the left is presented in the 2006 CNMI and Guam Stormwater Manual derived by Lander, 2004 (unpublished). The map on the bottom left is derived from rainfall data records from the period between 1950-1999 (Gingrich, 2003), which is presumably older. More climatic information can be found at www.hydroguam.net/map-clim-rainfall.php. The map on the bottom right is from www.prism.oregonstate.edu/products/pacisl.phtml, for a period of record ranging from 1971-2000.

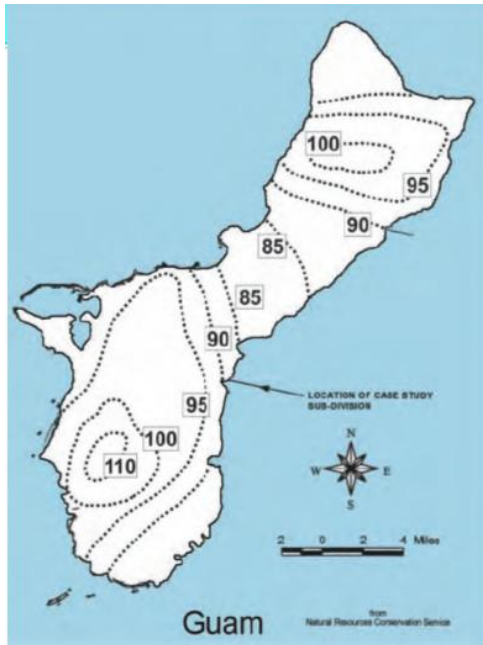

Location	Average Annual Rainfall (in)
Agat	95
Guam Int'l Airport	85
Hagatna	90
Inarajan	85
Taguac, Finegayan	100
Talofof	95
Umatac	100

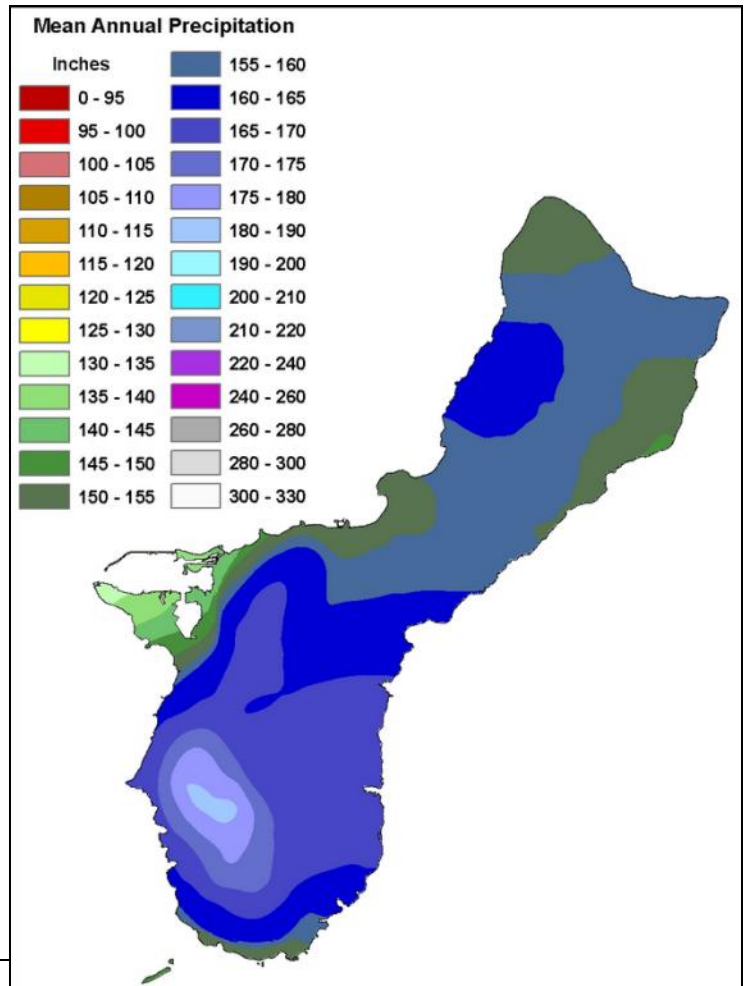
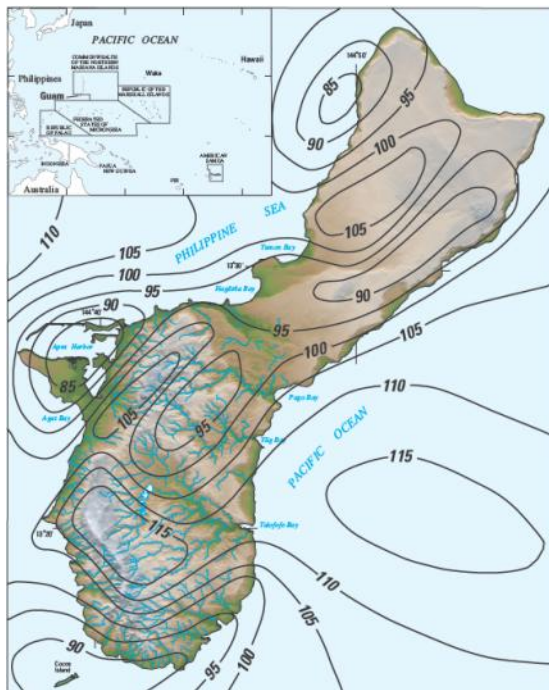

Rainfall Frequency Maps

The following map excerpts from NOAA Atlas 14, Vol. 5, Version 3, 2011 (online: http://hdsc.nws.noaa.gov/hdsc/pfds/pfds_maps.html) show average rainfall depths for selected recurrence intervals over a 24-hour duration for Guam. The period of record used appears to be 1978-2008.

1-yr, 24-hr

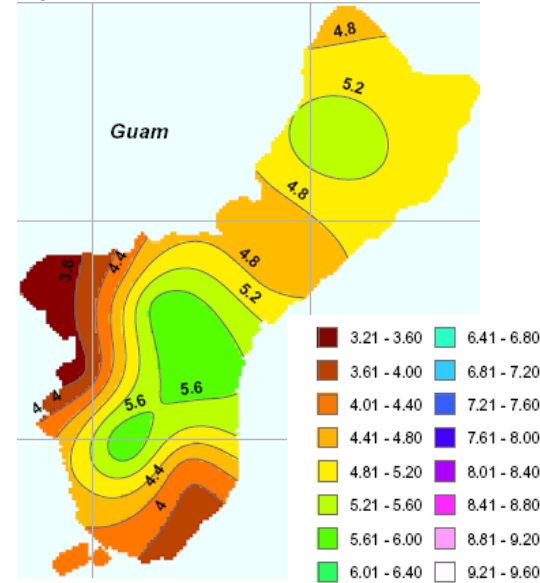

2-yr, 24-hr

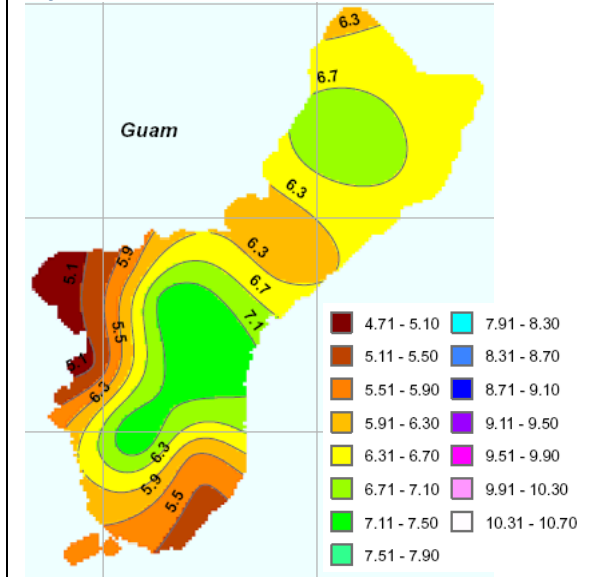

10-yr, 24-hr

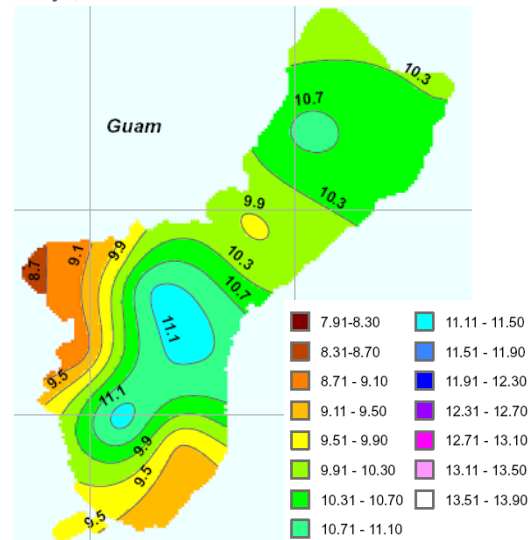

25-yr, 24-hr

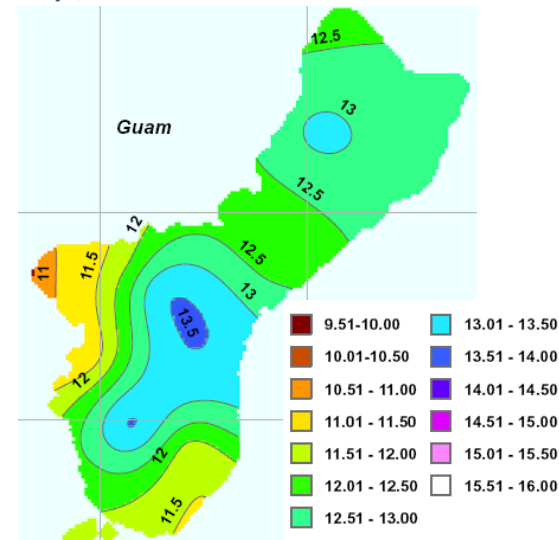

100-yr, 24 hr

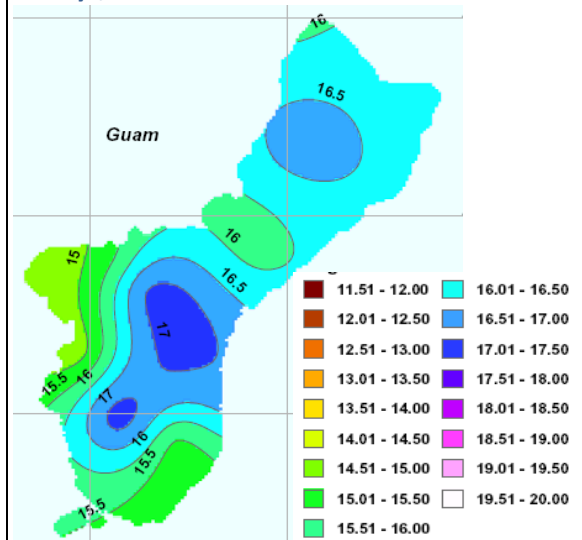

Rainfall Analysis

A rainfall analysis was conducted for the 2006 CNMI and Guam Stormwater Manual. Rainfall values were derived from a precipitation frequency analysis from the long-term continuous meteorological observatory on northern Guam by WERI (2004). At the time the stormwater manual was developed, the rainfall records for other parts of Guam were considered short or incomplete. Thus, for locations other than northern Guam, the manual requires designers to apply an adjustment factor when calculating the design storm events for 1-yr storms and greater. The table below shows the rainfall depths for common recurrence intervals in Northern Guam. The adjustment factor map on the right shows which factor to use based on your site location. For example, to calculate the rainfall depth for the 1-yr storm for a project in Tumon, multiply 3.5 inches x 0.9 factor, for an adjusted depth of 3.15 inches.

24-hour Rainfall Events for Northern Guam (adapted from Lander, 2004)

Recurrence Interval (years)	Exceedance Frequency (%)	Average Rainfall (inches)	Adjustment Factor
1	100	3.5	
2	50	7.0	
10	10	10.0	
25	4	20.0	
50	2	27.0	

You may notice that these average values differ from those generated from NOAA Atlas 14 PFDS (http://hdsc.nws.noaa.gov/hdsc/pfds/pfds_maps.html) for return intervals at selected rain gauging stations. For example, the estimated average depth for the 1-yr storm in northern Guam based on the analysis in the 2006 Manual was 3.5 inches. Using NOAA Atlas 14 isopluvial maps, it appears closer to 5.2 inches. For the bigger storms, 25-yr and up, the average values in the 2006 Manual are higher than what is generated by NOAA Atlas 14.

The NOAA Atlas period of record for Guam rain gauging stations appears to be 1978-2008, but it is unclear if this data is “better” than what was generated by WERI, or if the extended period of record more accurately reflects changing climate patterns. Regardless, the Manual establishes minimum target volumes, but managing for a higher volume may be the more conservative approach, which we would recommend where practical.

In the 2006 Stormwater Manual, the water quality standard requires management of the 90th and 80th percentile storms, which are estimated to be 1.5 and 0.8 inches, respectively. This is based on the northern Guam rainfall data that is plotted below in the frequency distribution graph.

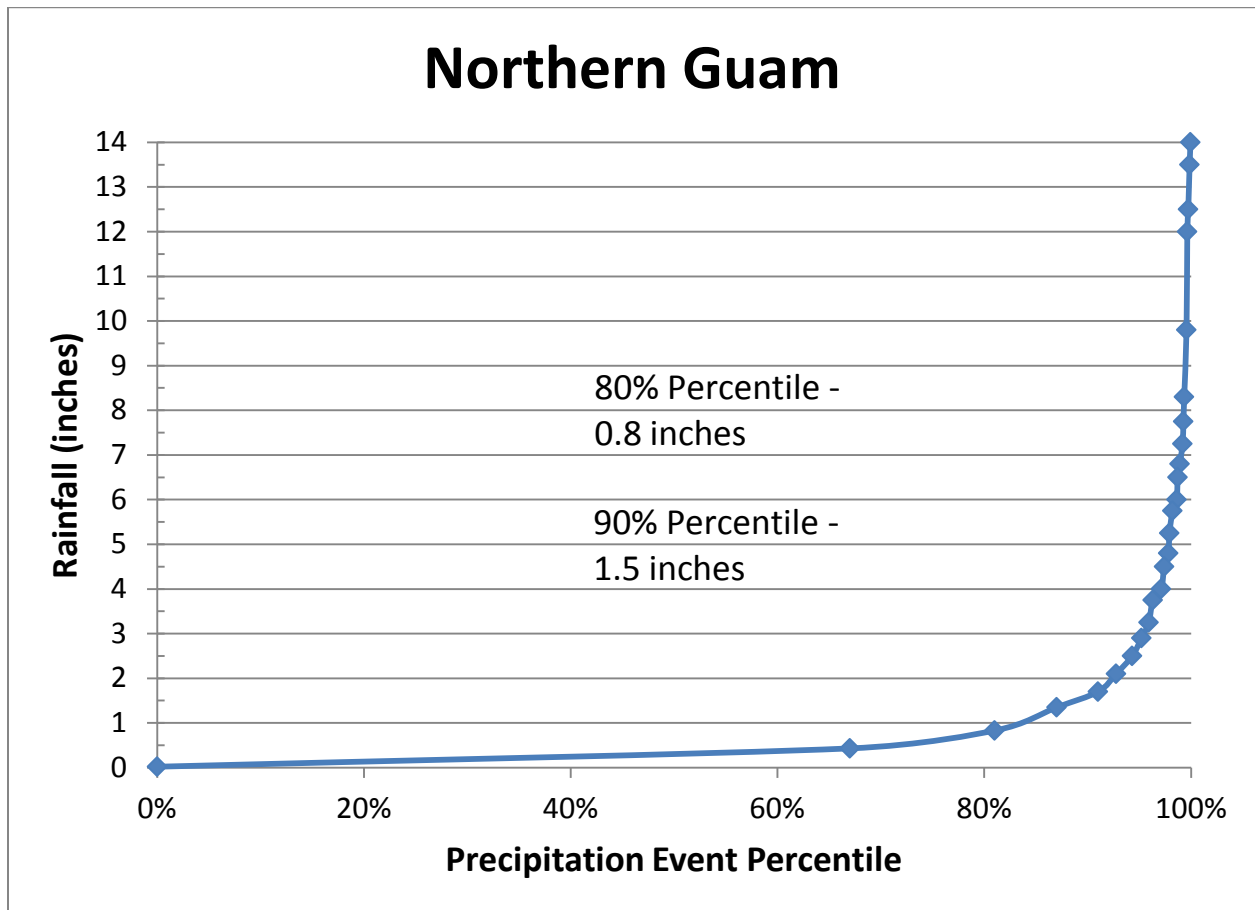

The table and graphic below provide updated frequency data using PACRAIN.

Site	# Rain Events ¹	Average Rain Depth (inches)					
		PACRAIN		From NOAA PFDS			
		90th Percentile Event ¹	95th Percentile Event ¹	1-yr, 24-hr	10-yr, 24-hr	25-yr, 24-hr	100-yr, 24-hr
Andersen Air Force Base	11113	1.01	1.61	5.01 (4.25-5.96)	10.4 (8.73-12.5)	12.7 (10.6-15.3)	16.3 (13.4-20.1)
Okkodo High School	10059	0.99	1.59				
Dededo	7515	1.12	1.72	5.02 (3.97-6.40)	10.4 (8.13-13.3)	12.7 (9.85-16.4)	16.3 (12.4-21.5)
Mongmong-Toto-Maite	14900	0.96	1.48				
Near Inarajan	5460	1.14	1.91	4.19 (3.29-5.36)	9.56 (7.44-12.3)	11.9 (9.14-15.4)	15.5 (11.7-20.5)
Near Agat	5909	1.25	1.99	3.52 (2.80-4.46)	8.89 (7.00-11.4)	11.2 (8.73-14.4)	14.8 (11.4-19.4)

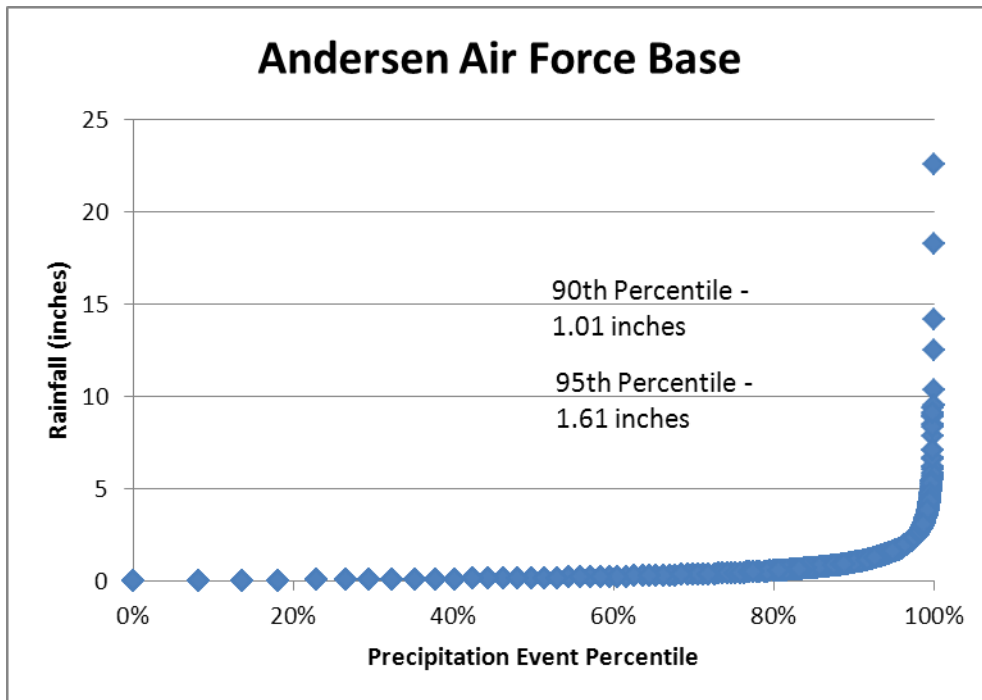

The following station map is provided from the NOAA PFDS website at http://hdsc.nws.noaa.gov/hdsc/pfds/pfds_map_pi.html. It shows the locations of some (if not all) of the referenced gauging stations.

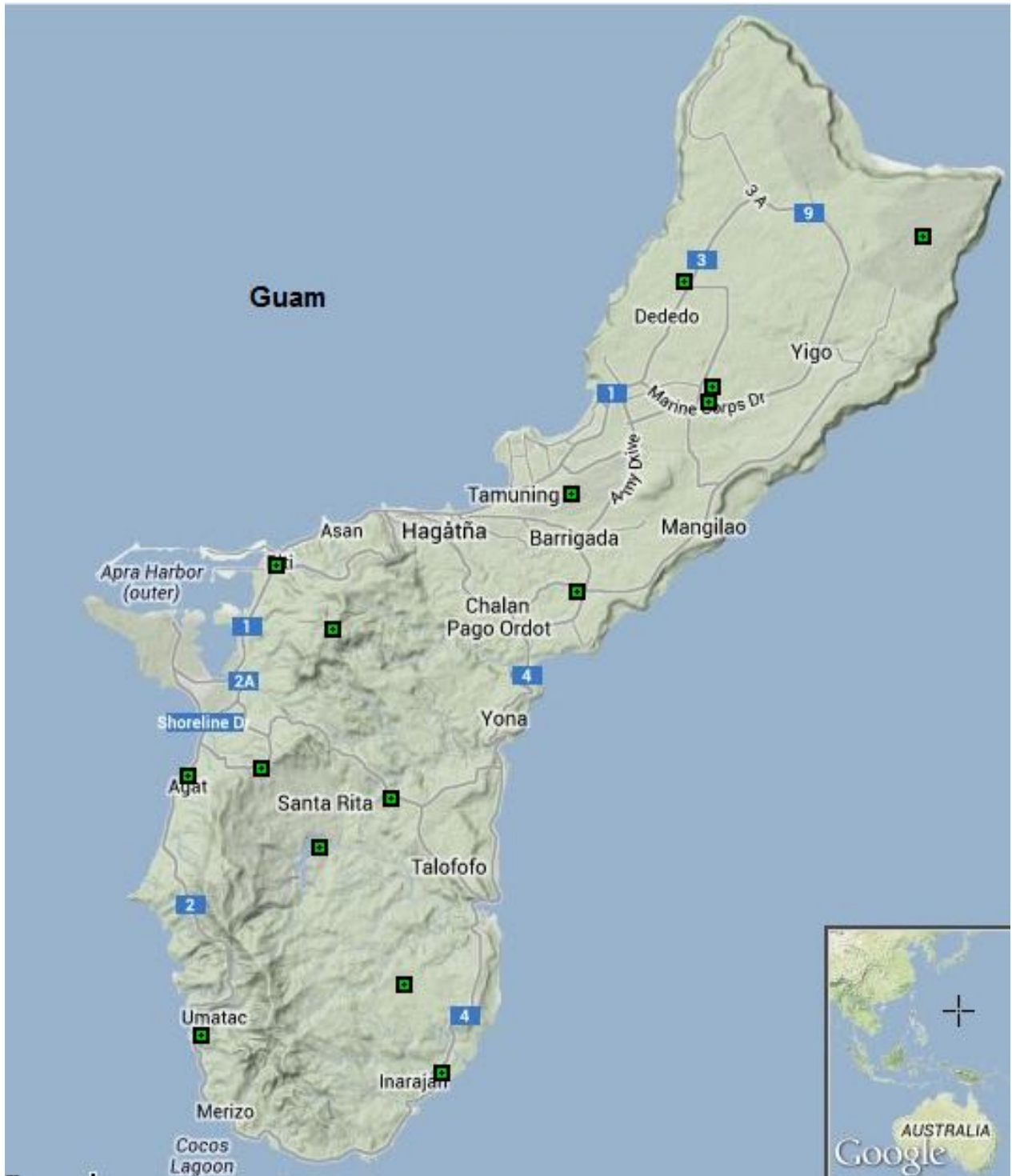

Hawaii

Stormwater Standards

There are three main requirements for relevant stormwater standards.

- Revised Rules Related to Stormwater Drainage Standards for the City and County of Honolulu (effective 2013) <http://www.cleanwaterhonolulu.com/storm/> and the Draft 2012 City and County of Honolulu Stormwater BMP Guide establish the 1 inch storm for the water quality treatment volume and water quality flow using the Rational Formula with a 0.4 inches/hour rainfall intensity for all projects greater than 1 acre, and for some with 10,000 sq ft of impervious cover.
- 2007 Hawaii Department of Transportation Stormwater Best Management Practices Manual <http://www.stormwaterhawaii.com/resources/>, in addition to establishing hydrologic design criteria for quantity control, also established 1-inch water quality treatment volume and methods for calculating the water quality flow for highway projects disturbing greater than 1-acre.
- Maui County Department of Public Works Rules for the Design of Storm Drainage Facilities in the County of Maui, Title 15, Chapter 4, Administrative Rules (rev 7/14/95) <http://www.co.maui.hi.us/index.aspx?NID=556> establishes required recurrence intervals and methodologies for hydrologic drainage criteria and water quantity treatment.

Annual Precipitation

The mean annual precipitation map for the Hawaiian islands is from Oregon State University Climate Center (2007) using partially gridded annual precipitation for the climatological period of 1971-2000. (www.prism.oregonstate.edu/products/pacisl.phtml). Average monthly data is also available.

Rainfall Frequency Maps

The following map excerpts from NOAA Atlas 14, Vol. 5, Version 3, 2011 (online: http://hdsc.nws.noaa.gov/hdsc/pfds/pfds_maps.html) show average rainfall depths for selected recurrence intervals over a 24-hour duration for Hawaii. The period of record used appears to be 1978-2008.

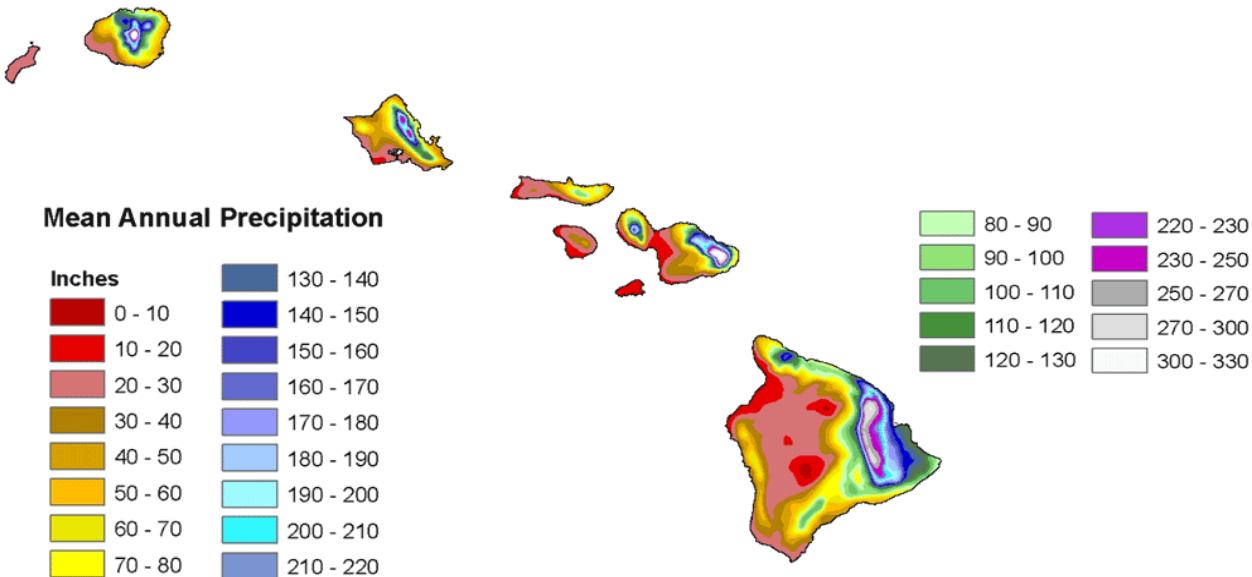

1-yr, 24-hr (not to scale)

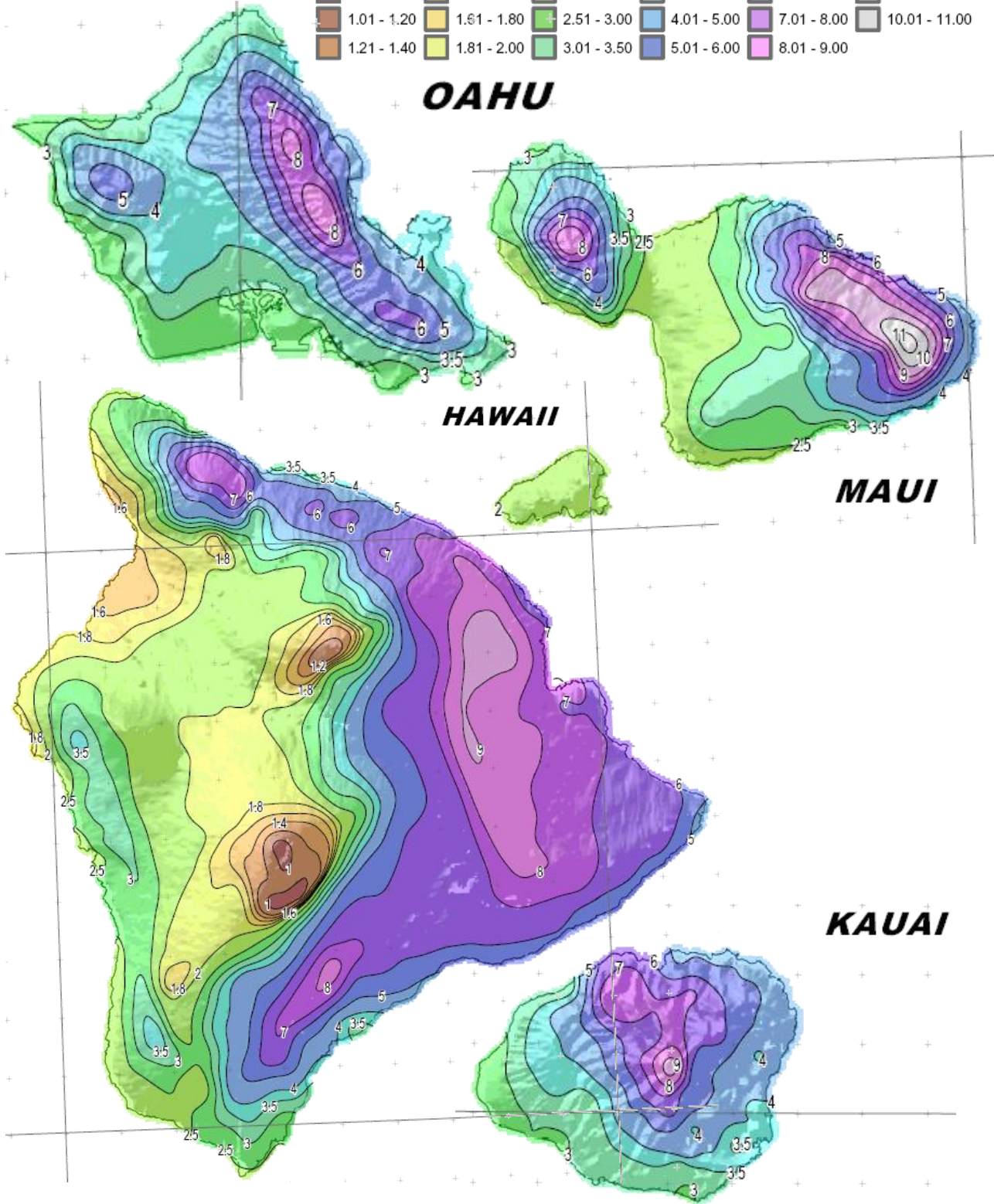

2-yr, 24-hr (not to scale)

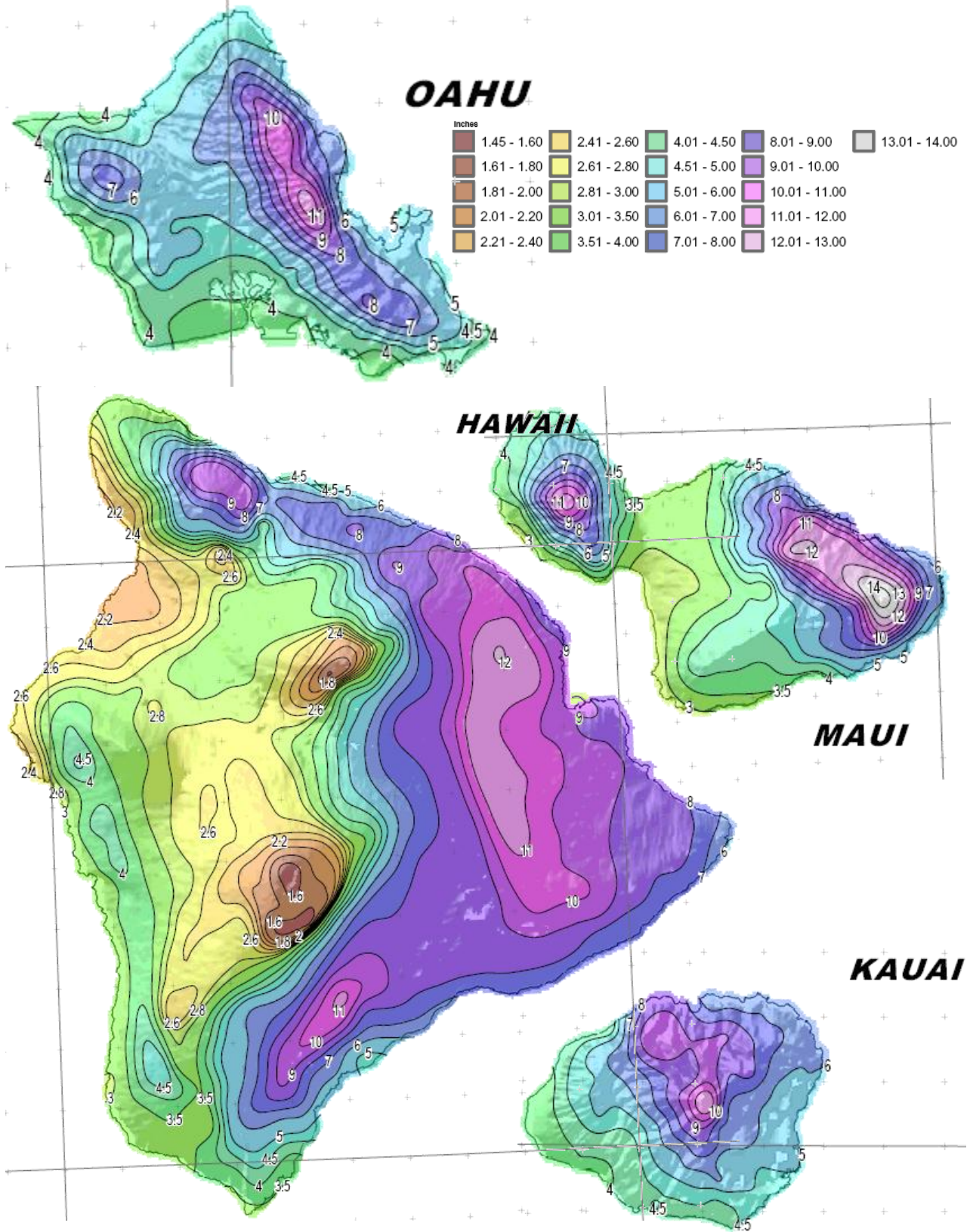

10-yr, 24-hr (not to scale)

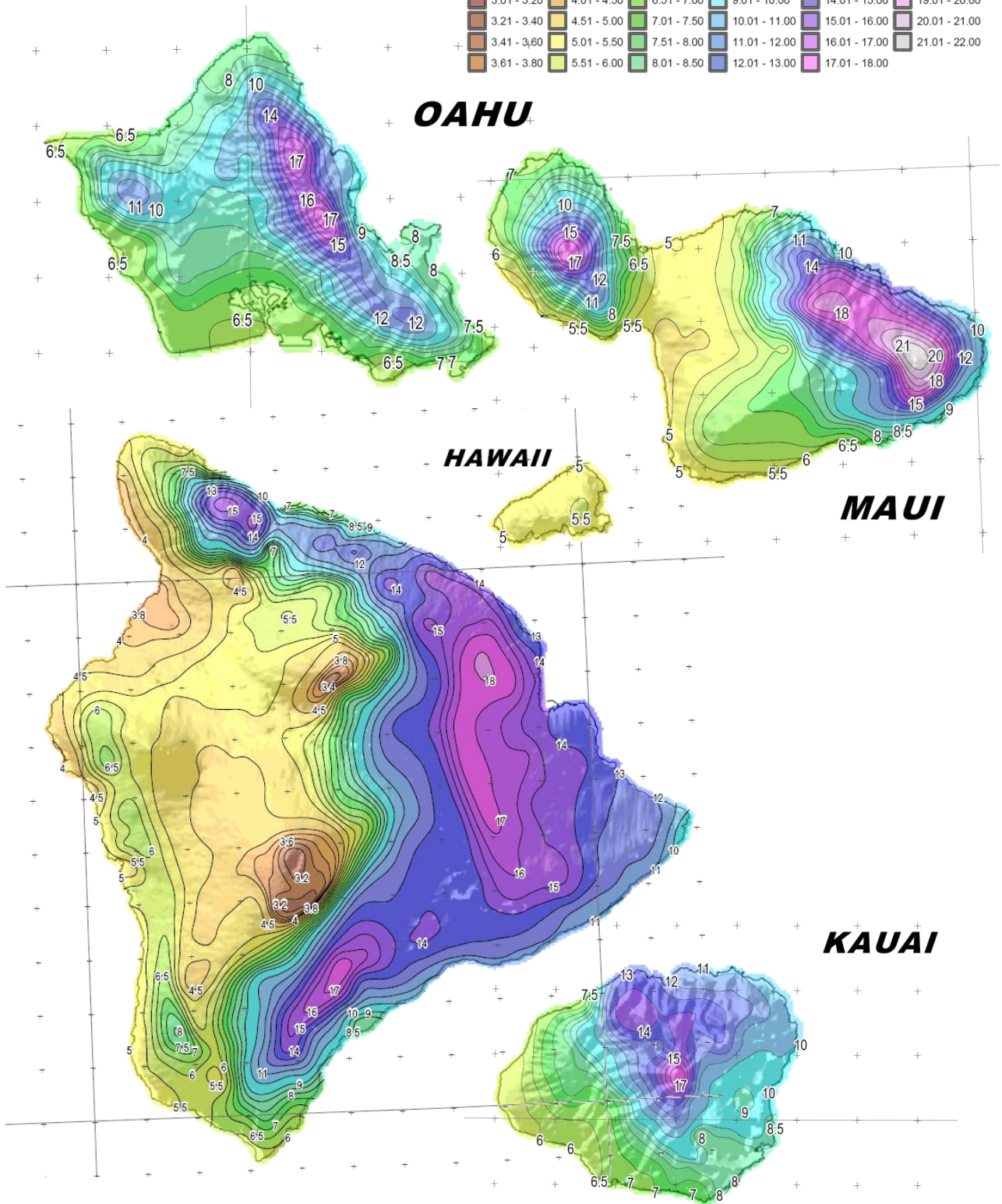
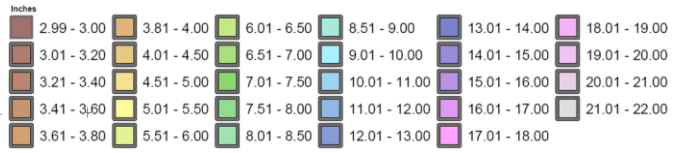

25-yr, 24-hr (not to scale)

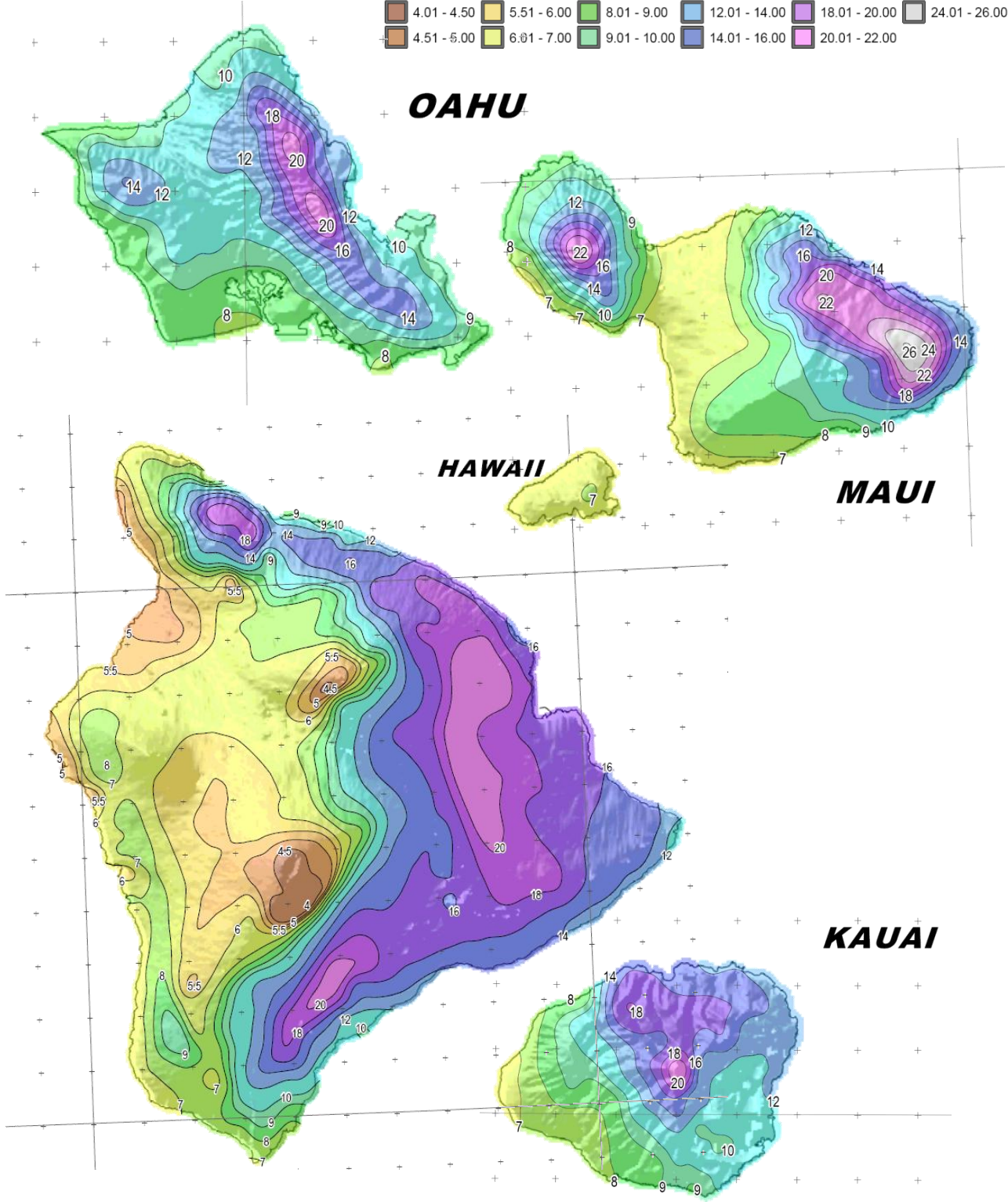

100-yr, 24-hr (not to scale)

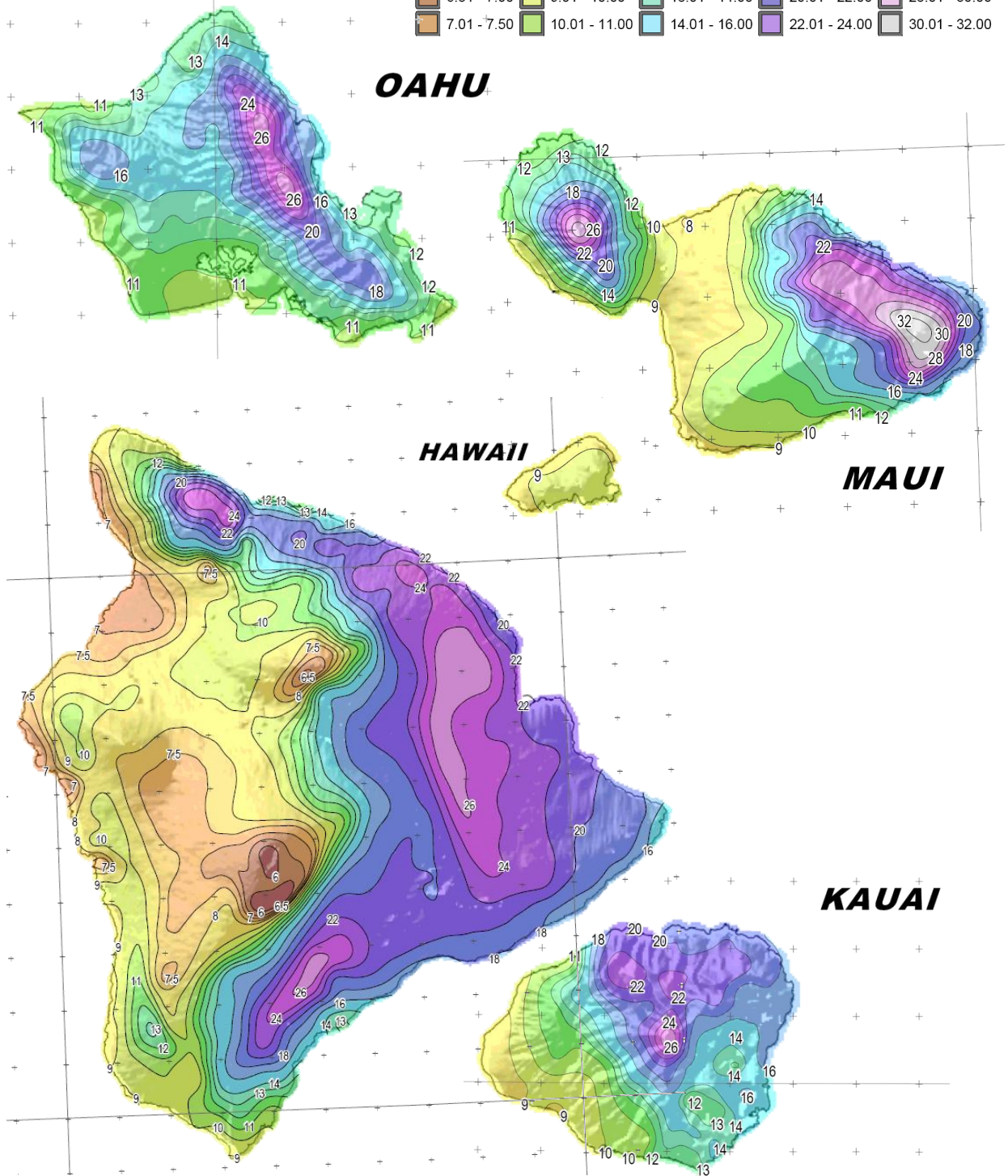
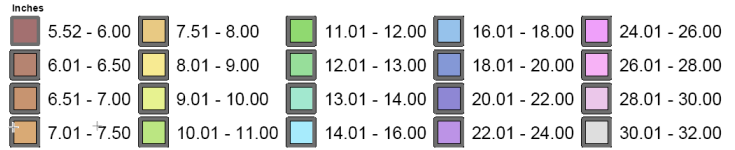

Rainfall Analysis

An analysis was conducted by Dr. Neil Berg in 2012 to generate percentiles at various stations on four of the Hawaiian islands. This information was used to develop guidance for rain garden designs by Hui o Ko'olaupoko.

Island	Gage	Year of Record	Annual Precip (inch)	90th %ile (inch)	95th %ile (inch)	% of Days with >= 90th
Maui	Kihei 311 (20.785N, 156.451W)	1905-2011	10.89	1.54	2.2	0.5
	Lahaina 361 (20.877N, 156.674W)	1916-2001	13.52	1.7	2.37	0.5
	Hamakuapoko 485 (20.913N, 156.346W)	1942-2012	48.11	0.85	1.28	2.8
Oahu	Waianae 798 (21.447N, 158.186W)	1950-2012	22.09	1.6	2.3	0.7
	Honolulu Internat'l Airport 759	1949-2012	22.18	1.44	2.23	0.9
	Paiko Drive 723.4 (21.282 N, 157.728W)	1976-2011	30.70	1.13	1.61	1.3
	Moanalua 770 (21.348N, 157.895W)	1905-2012	34.90	1.1	1.75	1.7
	Kailua Fire Stn 791.3 (21.397N, 157.739W)	1959-1978	37.32	1.42	2	1.7
	Waimanalo Nonokio 795.2 (21.330N, 157.710W)	1969-2010	42.09	1.4	2.15	1.7
	Kaneohe 838.1 (21.423N, 157.804W)	1905-2010	53.35	1.15	1.84	2.5
	Kaneohe Mauka 781 (21.408N, 157.811W)	1928-1998	69.49	1.23	1.95	3.4
	Tantalus 714 (21.327N, 157.817W)	1936-2012	100.00	1.21	1.73	4.7
Kauai	Lihue Airport 1020.1 (21.982N, 159.342W)	1950-2012	39.24	1.18	1.92	1.8
	Brydswood Sta. 985 (21.925N, 159.534W)	1951-2010	55.83	1	1.59	2.8
	Princeville Ranch 1117 (22.213N, 159.472W)	1938-2012	76.00	1	1.64	2.4
	Hanalei 1117.8 (22.190N, 159.490W)	1905-1909, 2004-2012	96.26	1.5	2.13	4
Hawaii	Hilo Airport 87 (19.720N, 155.050W)	1949-2011	130.04	1.39	2.2	5
	Kona Airport 68.3 (19.644N, 156.007W)	1949-1978	22.65	0.99	1.44	1.2

The table below summarizes data from NOAA Atlas 14 PFDS (http://hdsc.nws.noaa.gov/hdsc/pfds/pfds_maps.html) for selected rain gauging stations over a period of record starting in 1905.

Site	Average Rain Depth (inches)				
	1-yr, 24-hr	2-yr, 24-hr	10-yr, 24-hr	25-yr, 24-hr	100-yr, 24-hr
Lahaina, Maui	2.29 (1.96-2.68)	3.21 (2.75-3.77)	5.61 (4.77-6.62)	7.16 (6.02-8.48)	9.79 (8.05-11.7)
Hamakuapoko 485, Maui	2.86 (2.54-3.23)	3.79 (3.36-4.28)	6.07 (5.36-6.89)	7.42 (6.51-8.46)	9.56 (8.28-11.0)
Honolulu Int'l Airport 703, Oahu	2.87 (2.52-3.25)	3.93 (3.45-4.45)	6.61 (5.76-7.53)	8.29 (7.17-9.49)	11.0 (9.36-12.8)
Kailua Fire Stn 791.3, Oahu	3.79 (3.21-4.34)	5.05 (4.29-5.81)	7.95 (6.70-9.24)	9.55 (7.97-11.2)	11.9 (9.74-14.3)
Kaneohe Mauka 781, Oahu	4.56 (4.08-5.08)	6.06 (5.41-6.76)	9.79 (8.66-11.0)	12.1 (10.6-13.8)	15.8 (13.5-18.4)
Lihue Airport 1020.1, Kauai	3.64 (3.18-4.19)	5.02 (4.38-5.79)	8.51 (7.38-9.86)	10.7 (9.21-12.4)	14.3 (12.1-16.8)
Princeville Ranch 1117, Kauai	4.97 (4.33-5.75)	6.79 (5.90-7.85)	11.5 (9.89-13.5)	14.6 (12.4-17.3)	19.8 (16.3-24.0)
Hilo Airport 87, Hawaii	7.23 (6.60-7.96)	9.16 (8.34-10.1)	13.9 (12.6-15.3)	16.7 (15.0-18.6)	21.3 (18.8-23.8)
Kona Airport 68.3, Hawaii	1.90 (1.62-2.24)	2.56 (2.17-3.02)	4.23 (3.55-5.04)	5.29 (4.37-6.40)	7.05 (5.62-8.75)

Go to http://hdsc.nws.noaa.gov/hdsc/pfds/pfds_map_hi.html for access to station maps and statistics.

SELECT LOCATION

1. Manually:

a) Enter location (decimal degrees, use "-" for S and W): latitude: longitude:

b) Select station (click here for a list of stations used in frequency analysis for HI):

2. Use map:

Station List:

- KONA AIRPORT 68.3 (51-4764)
- KIPAHULU 258 (51-4634)
- KIPAPA (53-0103)
- KITANO RESERVOIR (53-0222)
- KOELE 693 (51-4660)
- KOHALA 179.1 (51-4670)
- KOHALA MAULILI 176 (51-4675)
- KOHALA MISSION 175.1 (51-4680)
- KOLO 1033 (51-4735)
- KOLOA 936 (51-4742)
- KOLOA MAUKA 994 (51-4750)
- KOLOA MILL (53-0204)
- KOLOKO RESERVOIR 1137 (51-4758)
- KONA AIRPORT 68.3 (51-4764)**
- KONA VILLAGE 93.8 (51-4765)
- KOOLAU DAM 833 (51-4766)
- KUALAPUU 534 (51-4778)
- KUKAIAU 222 (51-4815)
- KUKUIHAELE 206.1 (51-4927)
- KUKUIHAELE MILL 206 (51-4938)
- KUKUIULA 935 (51-4950)

LOCATION INFORMATION:

Name: Kailua-Kona, Hawaii, US*
Station Name: KONA AIRPORT 68.3
Site ID: 51-4764
Latitude: 19.6500
Longitude: -156.0167
Elevation: 30 ft

Pacific island water center <http://hi.water.usgs.gov/>

Puerto Rico

Stormwater Standards

Standards for guiding post-construction BMP sizing for water quality treatment, recharge, or other management targets are not established in Puerto Rico.

Annual Precipitation

http://www.srh.noaa.gov/sju/?n=mean_annual_precipitation2

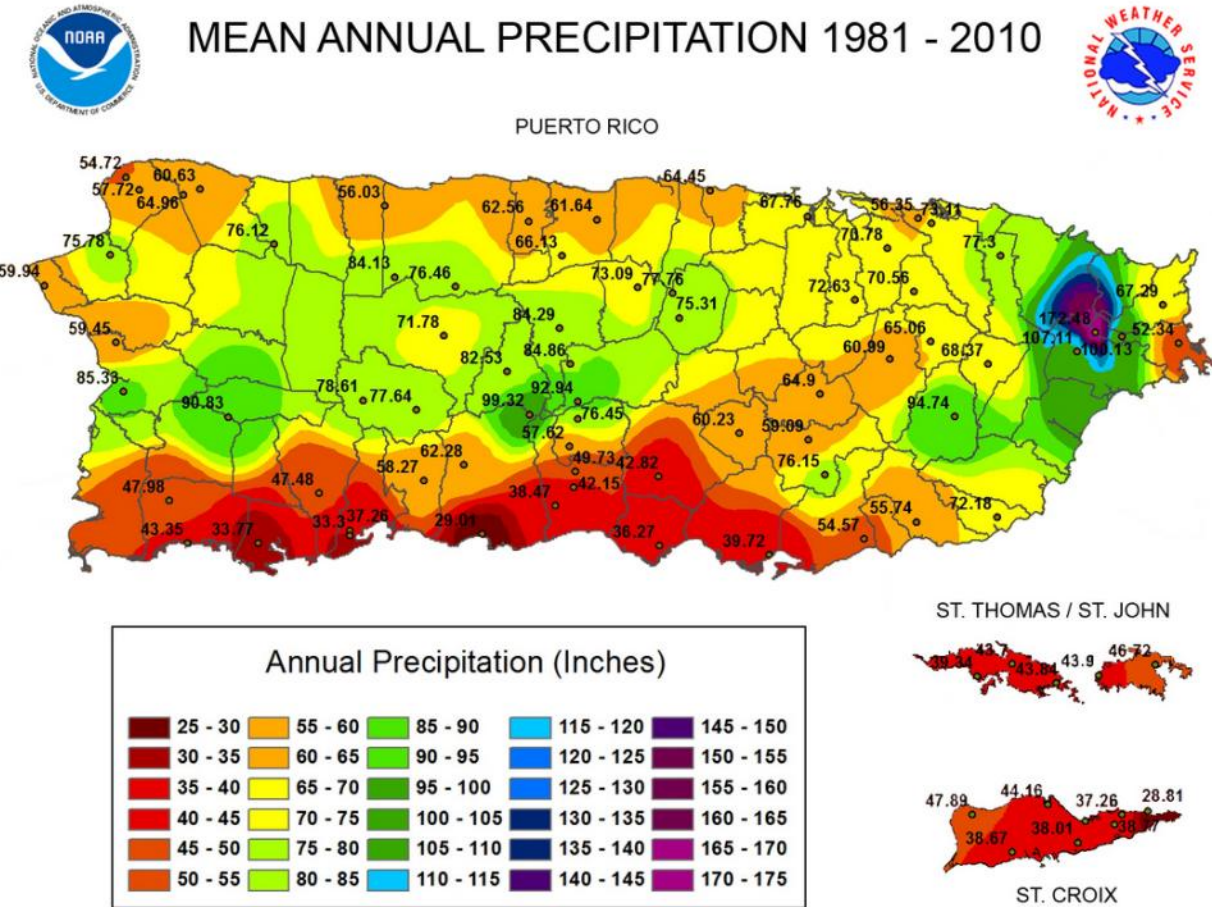

Rainfall Frequency Maps (http://hdsc.nws.noaa.gov/hdsc/pfds/pfds_maps.html)

1-yr, 24-hr (not to scale)

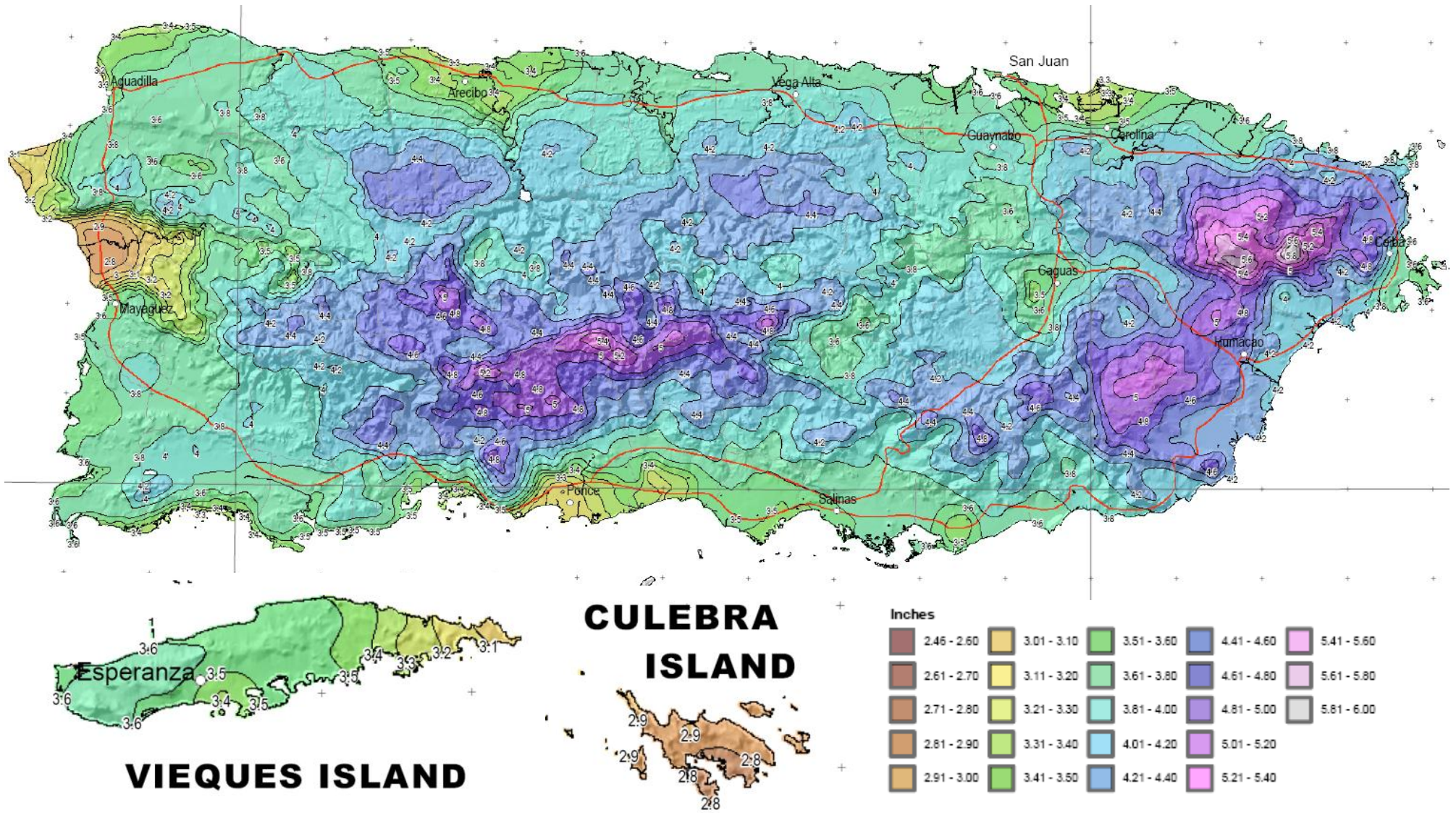

2-yr, 24-hr (not to scale)

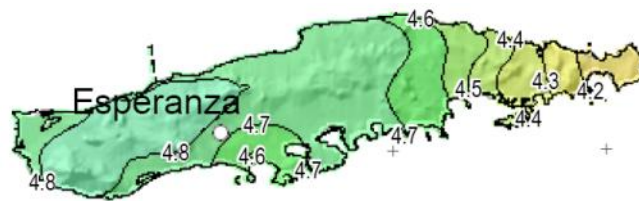
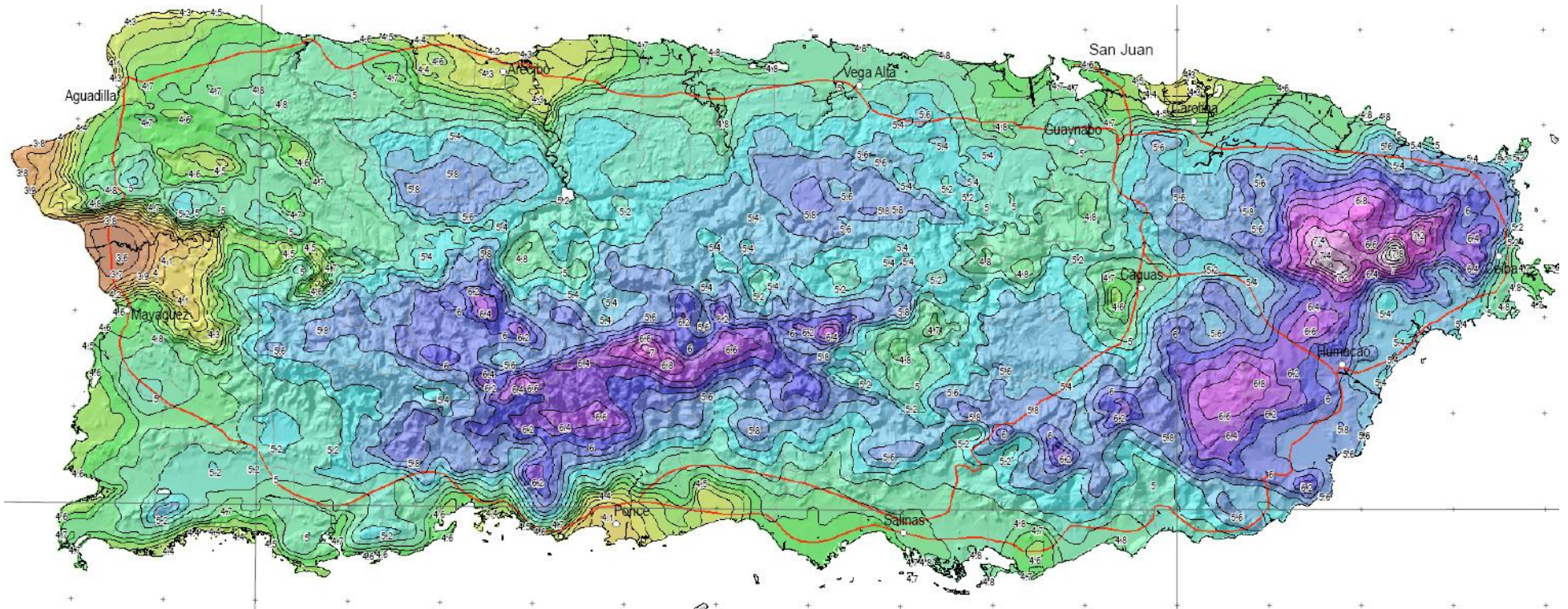

VIEQUES ISLAND

CULEBRA ISLAND

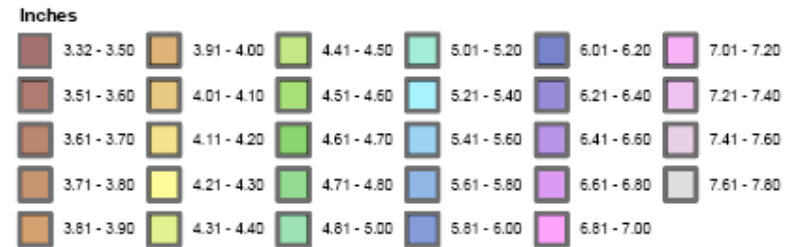
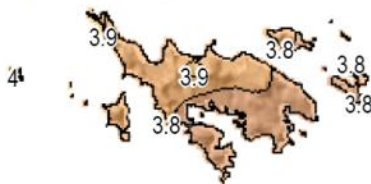

10-yr, 24-hr (not to scale)

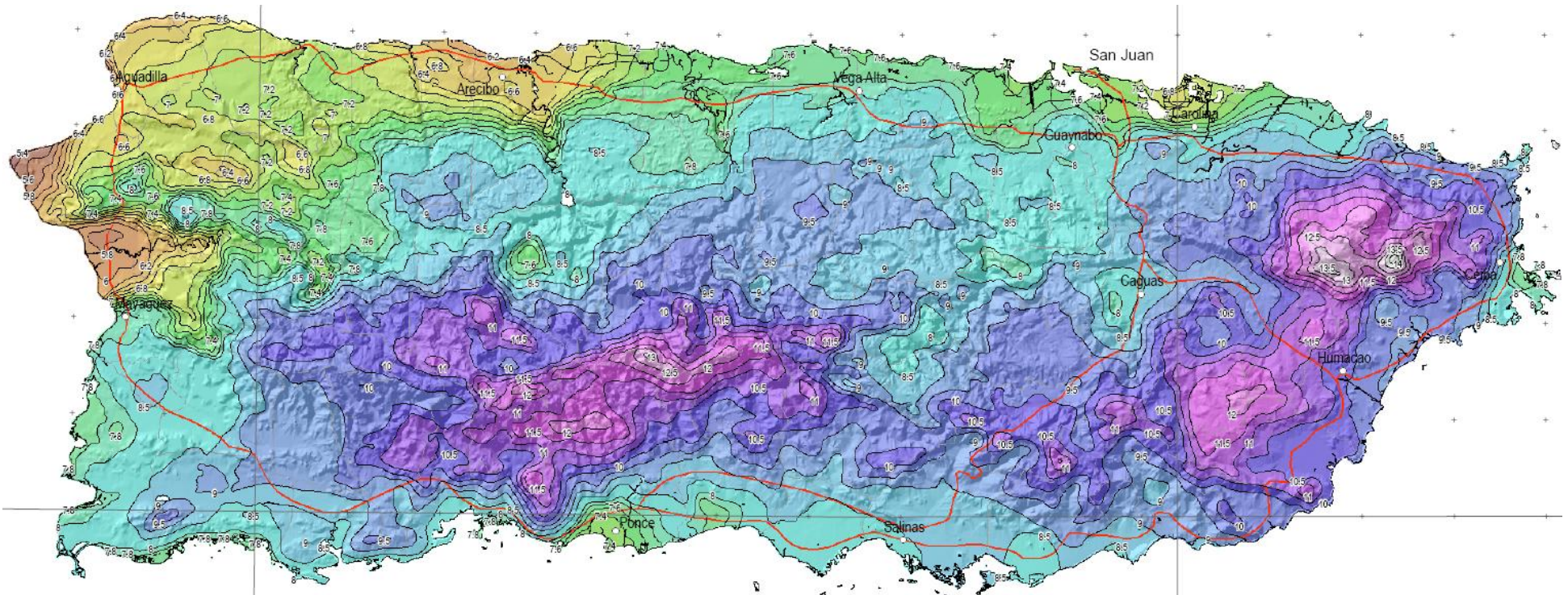

VIEQUES ISLAND

CULEBRA ISLAND

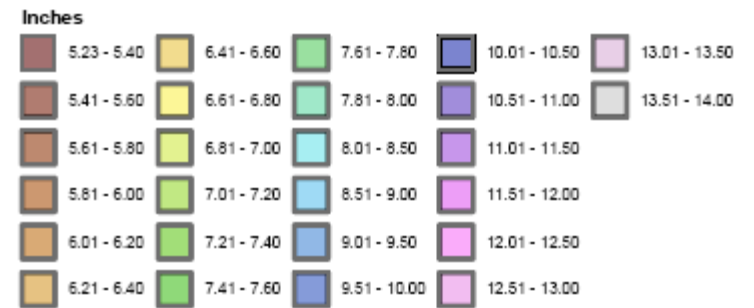
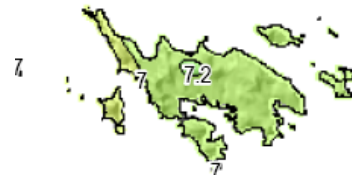

25-yr, 24-hr (not to scale)

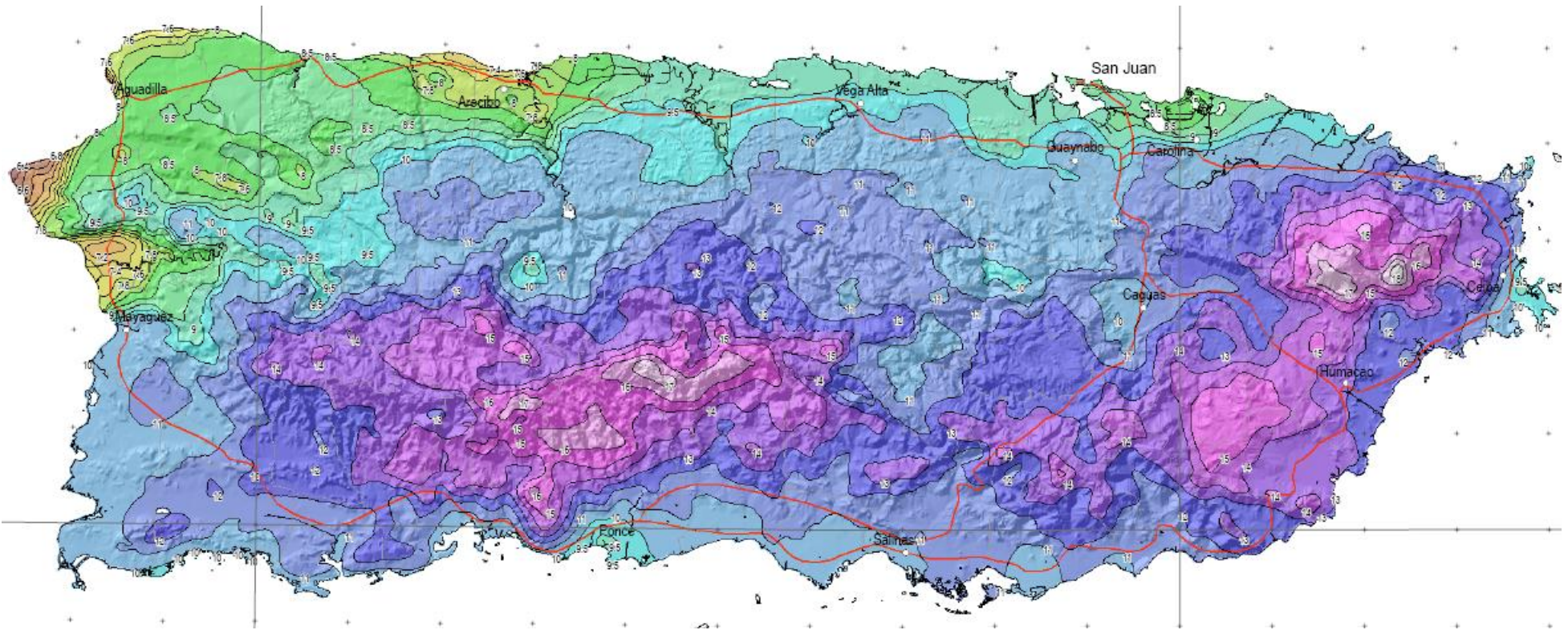

VIEQUES ISLAND



CULEBRA ISLAND

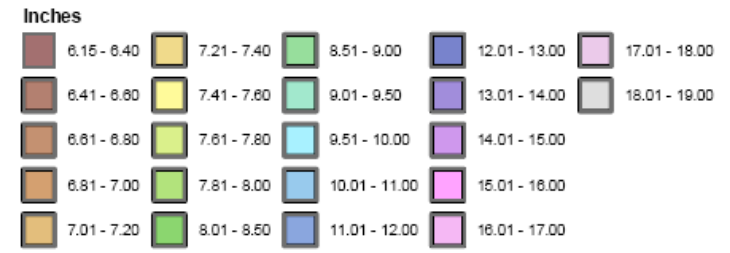

100-yr, 24-hr (not to scale)

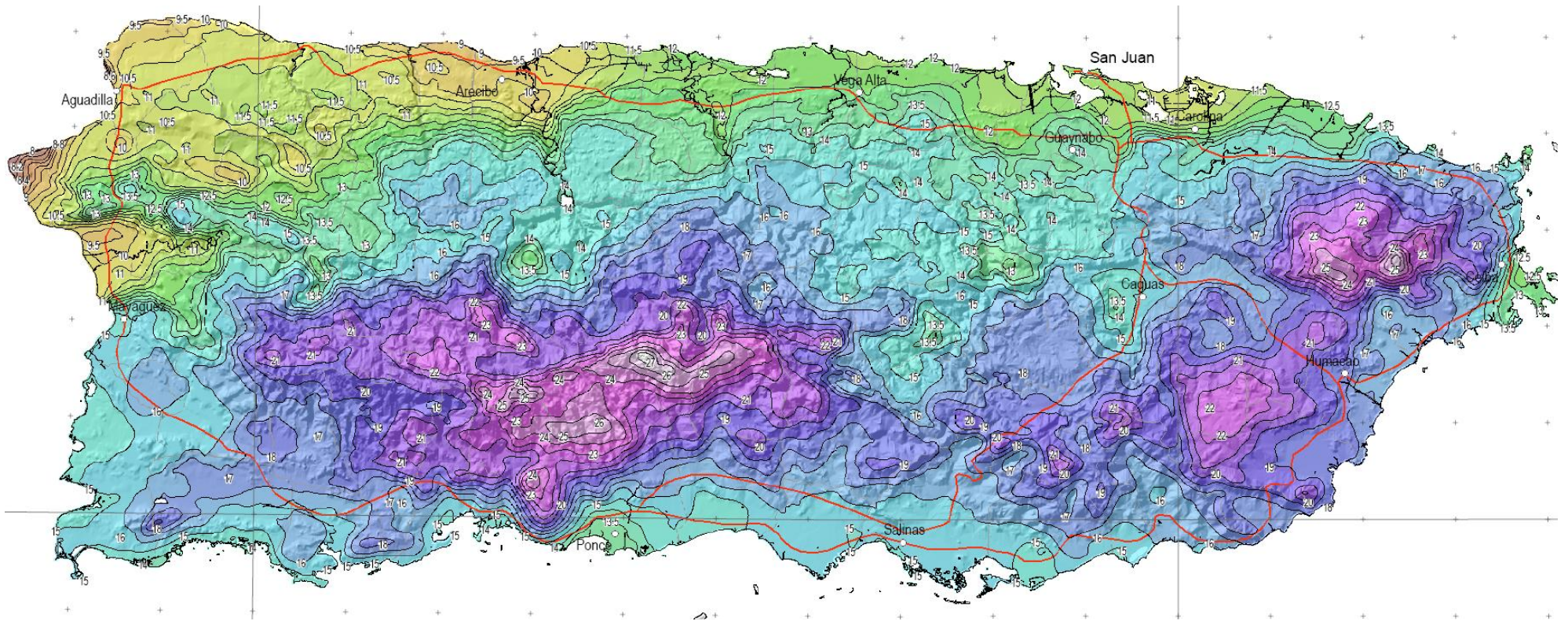

VIEQUES ISLAND



CULEBRA ISLAND

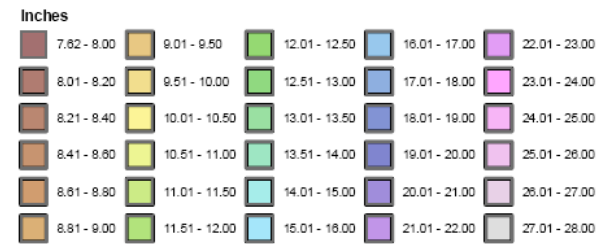

Rainfall Analysis

Table below summarizes data from two sources: a local dataset (Hirschman, nd) and NOAA Atlas 14 PFDS (http://hdsc.nws.noaa.gov/hdsc/pfds/pfds_maps.html) for selected rain gauging stations.

Site	# Rain Events	Average Rain Depth (inches)					
		Local data		From NOAA Atlas 14			
		90th Percentile Event	95th Percentile Event	1-yr, 24-hr	10-yr, 24-hr	25-yr, 24-hr	100-yr, 24-hr
San Juan	6957	0.79	1.23	3.53 (3.27-3.85)	7.31 (6.72-7.96)	8.96 (8.18-9.74)	11.7 (10.5-12.8)
Culebra Island				2.72 (2.33-3.22)	7.12 (6.04-8.41)	9.45 (7.89-11.1)	13.6 (11.1-15.9)
Caguas				3.55 (2.89-4.44)	8.32 (6.76-10.4)	10.7 (8.69-13.4)	15.0 (11.9-18.8)
Lares				3.93 (3.69-4.25)	7.59 (6.96-8.28)	9.50 (8.55-10.5)	12.9 (11.2-14.7)
Yauco 1NW				4.42 (3.56-5.45)	10.6 (8.43-13.0)	13.9 (10.9-17.1)	19.9 (15.3-24.6)
Ponce				3.11 (2.83-3.45)	7.41 (6.73-8.19)	9.66 (8.70-10.7)	13.6 (12.1-15.1)
Vieques Island				3.38 (3.09-3.76)	8.83 (7.92-9.71)	11.7 (10.3-12.9)	16.8 (14.4-18.6)
CERRO MARAVILLA				5.20 (4.38-6.21)	12.6 (10.4-15.1)	17.2 (14.0-20.6)	26.4 (20.7-31.5)

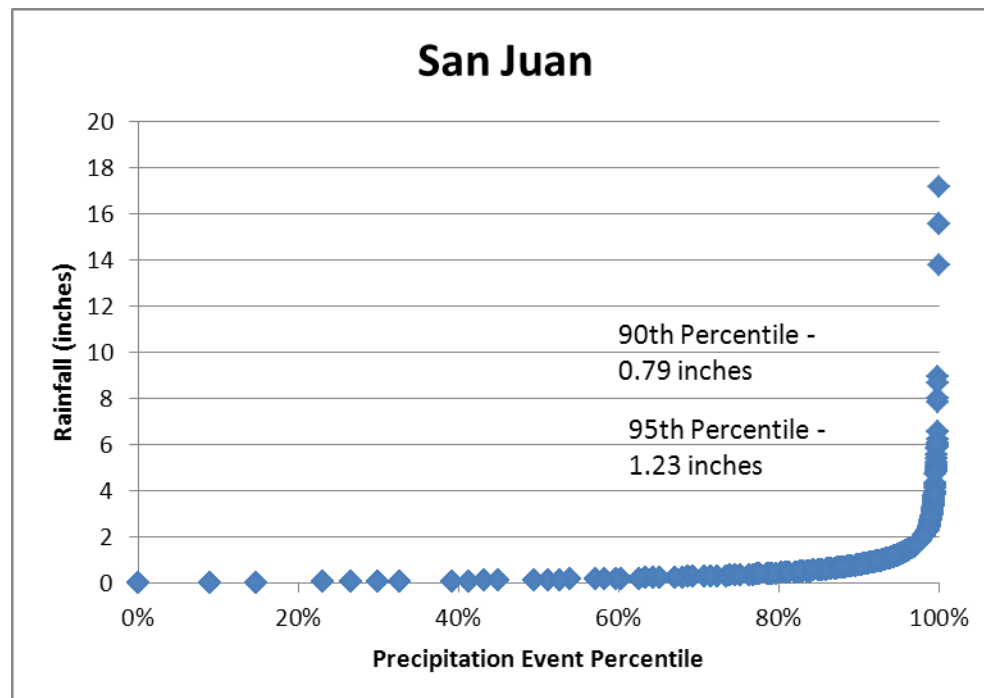

For station maps, go to http://hdsc.nws.noaa.gov/hdsc/pfds/pfds_map_pr.html, where you can click on station of interest in order to generate rainfall data.

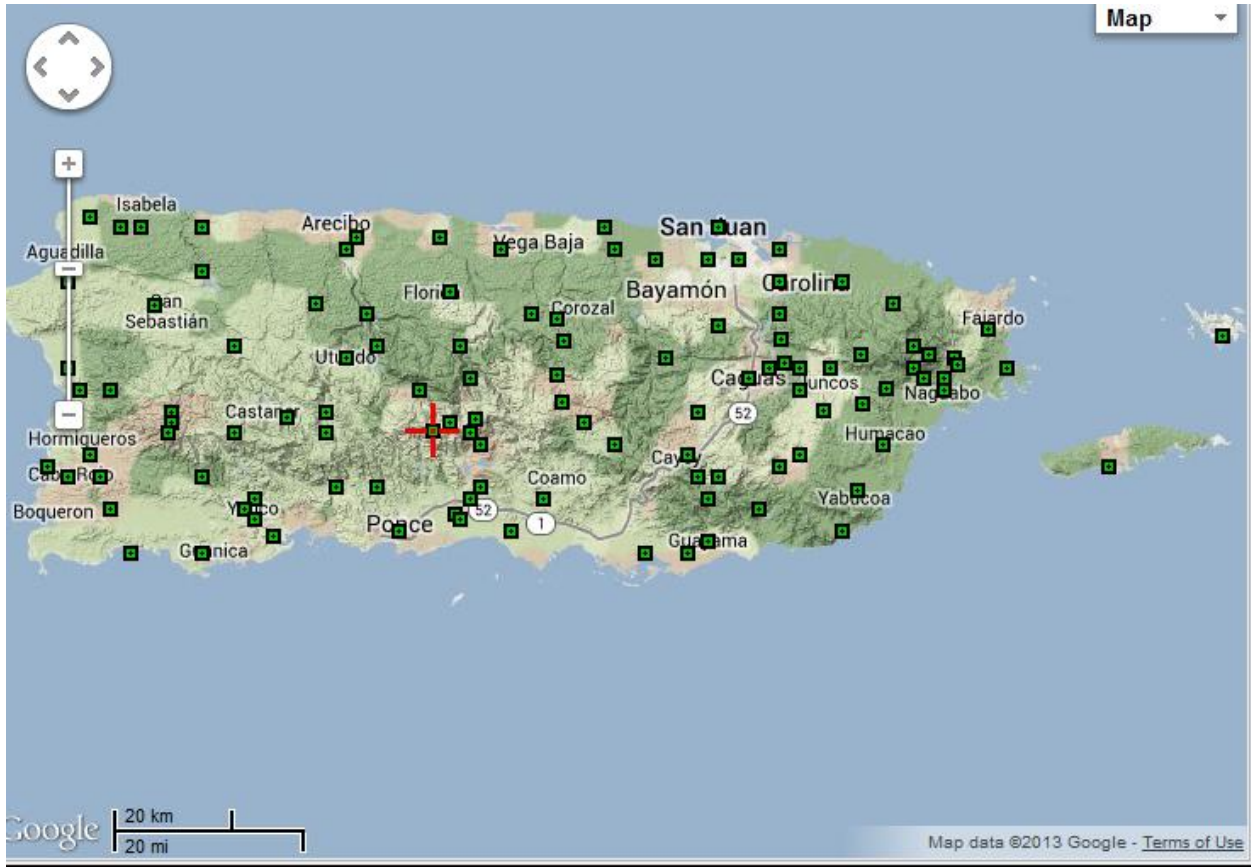

US Virgin Islands

Stormwater Standards

The USVI doesn't currently have established post-construction stormwater BMP sizing criteria. The 2002 Environmental Handbook provides some design guidance.

Annual Precipitation

The mean annual precipitation map below of the Virgin Islands is from Oregon State University Climate Center (2004) using partially gridded annual precipitation for the climatological period of 1971-2000.

(www.prism.oregonstate.edu/products/pacisl.phtml).

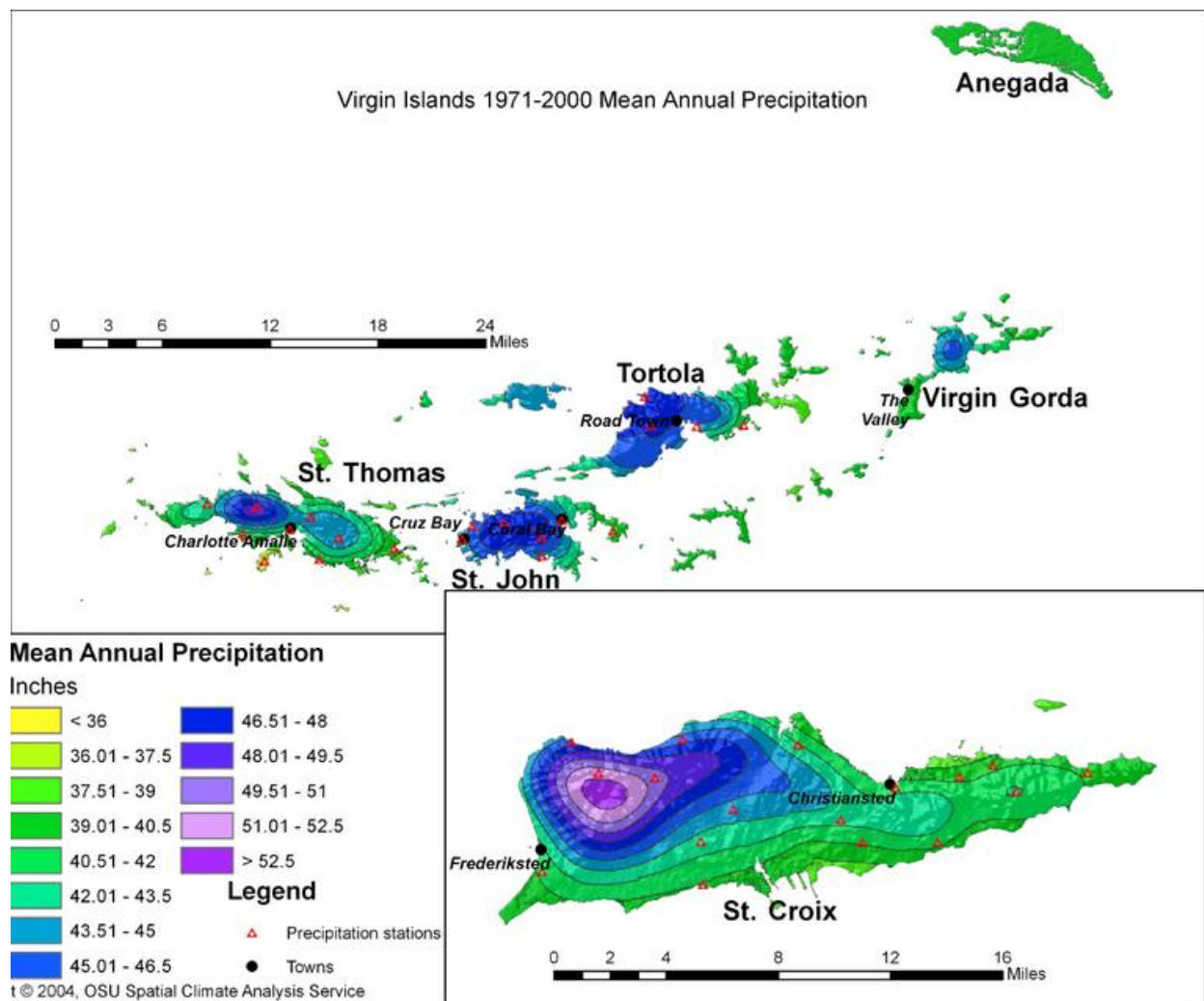

Copyright © 2011, PRISM Climate Group, Oregon State University, <http://prism.oregonstate.edu>

Rainfall Frequency Maps

Table below includes excerpts of average rainfall depth maps for 24-hr duration storms from the 2006 NOAA Atlas 14: US Precipitation Frequency Atlas, Vol. 3: Puerto Rico and the USVI, Ver. 3. The period of record on average is 54 years of daily records through 2004.

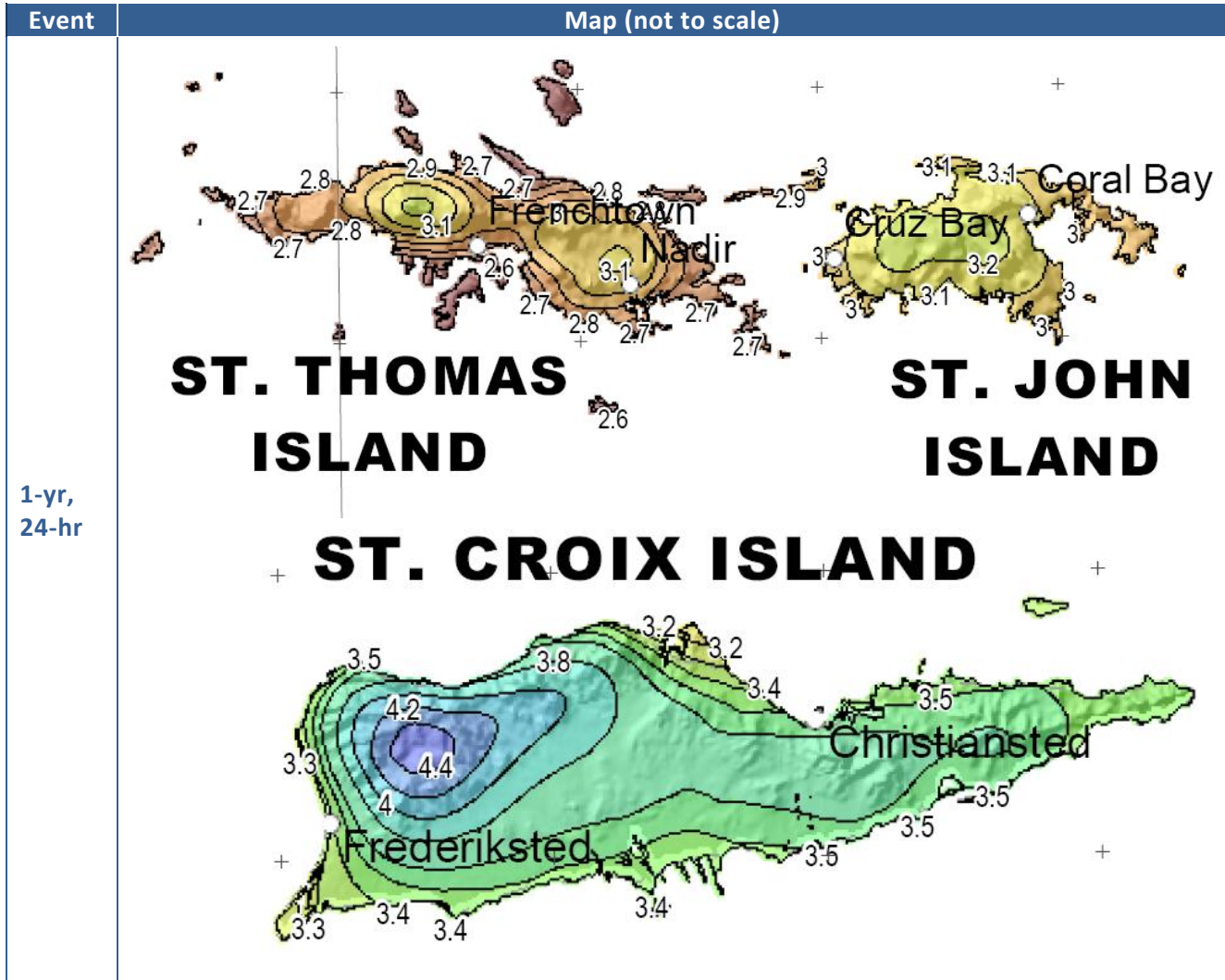

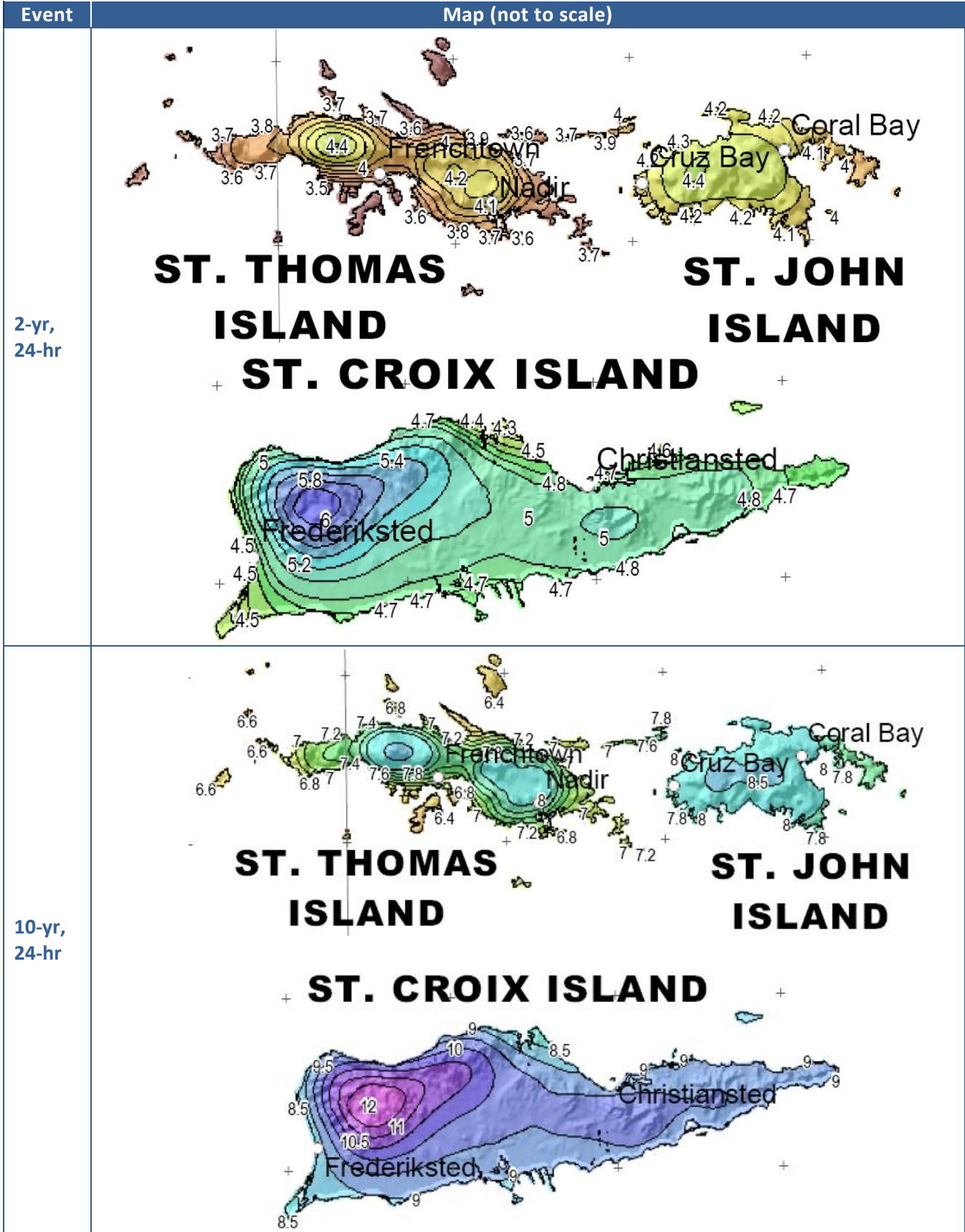

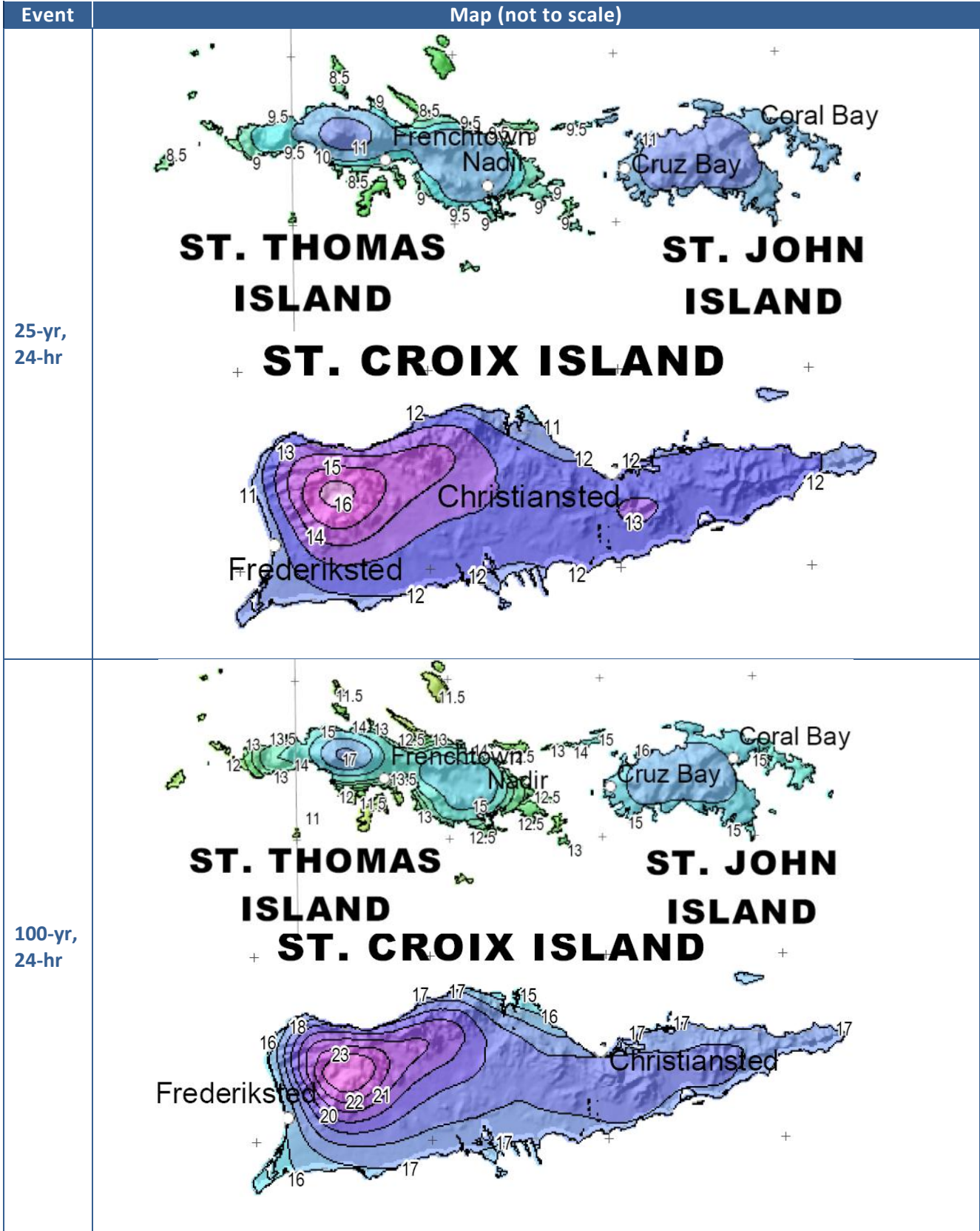

Rainfall Analysis

Cadmus (2011) developed precipitation frequency estimates for watersheds of the USVI using the National Oceanic and Atmospheric Administration's (NOAA) Precipitation Frequency Atlas of the United States (Bonnin, 2006). Precipitation frequency data in 90-meter resolution ASCII grid format were obtained from the NOAA Precipitation Data Frequency Server (PFDS) and processed using ArcGIS to derive watershed scale precipitation frequency estimates. Magnitudes for storms of 24-hour duration for typical return intervals were estimated for each 14-digit HUC. In general, St. Croix receives the largest amount of rainfall, while St. Thomas receives the smallest. Rainfall variability is highest for St. Croix watersheds.

Station Name & ID	Island	Record Start Date	Record End Date	% Missing Records	90 th Percentile Storm Depth (inches)	95 th Percentile Storm Depth (inches)	Mean Storm Depth (inches)
Christiansted Airport (670198)	St. Croix	1981	2008	4	0.9	1.4	0.5
Christiansted Fort (671740)	St. Croix	1972	2008	32	1.0	1.5	0.5
East Hill (672560)	St. Croix	1972	2008	5	1.0	1.6	0.5
Montpellier (674900)	St. Croix	1979	2008	10	1.1	1.6	0.5
Coral Bay (671790)	St. John	1972	2008	20	0.9	1.4	0.5
Cruz Bay (671980)	St. John	1972	2008	14	1.1	1.7	0.5
East End (672551)	St. John	1972	2008	17	1.2	1.9	0.5
Redhook Bay (677600)	St. Thomas	1980	2008	37	1.3	2.0	0.6
Charlotte Amalie Airport (678905)	St. Thomas	1972	2010	14	1.0	1.5	0.5
Wintberg (679450)	St. Thomas	1972	2008	8	1.1	1.6	0.5

HUC	Magnitudes (inches) of 24-hour Duration Storms for Different Return Intervals						
	1 Year	2 Years	5 Years	10 Years	25 Years	50 Years	100 Years
Northeast St. Croix (21020002010030)	3.5	4.8	7.3	9.3	12.4	15.0	17.8
Southeast St. Croix (21020002020010)	3.6	4.9	7.3	9.4	12.6	15.2	18.1
Northcentral St. Croix (21020002010020)	3.7	5.0	7.5	9.7	12.9	15.6	18.6
Airport St. Croix (21020002020030)	3.8	5.2	7.9	10.2	13.5	16.4	19.6
Southwest St. Croix (21020002020040)	3.7	5.0	7.6	9.7	12.9	15.7	18.6
Northwest St. Croix (21020002010010)	3.9	5.3	8.0	10.3	13.7	16.6	19.8
Southparts St. Croix (21020002020020)	3.6	4.9	7.4	9.5	12.6	15.2	18.1
North St. John (21020001020010)	3.1	4.3	6.4	8.2	10.9	13.3	15.8
Southeast St. John (21020001020020)	3.1	4.2	6.4	8.2	10.9	13.2	15.7
Southwest St. John (21020001020030)	3.2	4.3	6.5	8.4	11.2	13.6	16.1
Southwest St. Thomas (21020001010040)	2.9	3.9	5.8	7.5	9.9	12.0	14.2
Southeast St. Thomas (21020001010030)	3.0	4.0	6.1	7.8	10.3	12.5	14.8
Northeast St. Thomas (21020001010020)	2.9	3.9	5.8	7.5	9.8	11.8	13.9
Northwest St. Thomas (21020001010010)	2.9	4.0	6.0	7.7	10.2	12.4	14.7

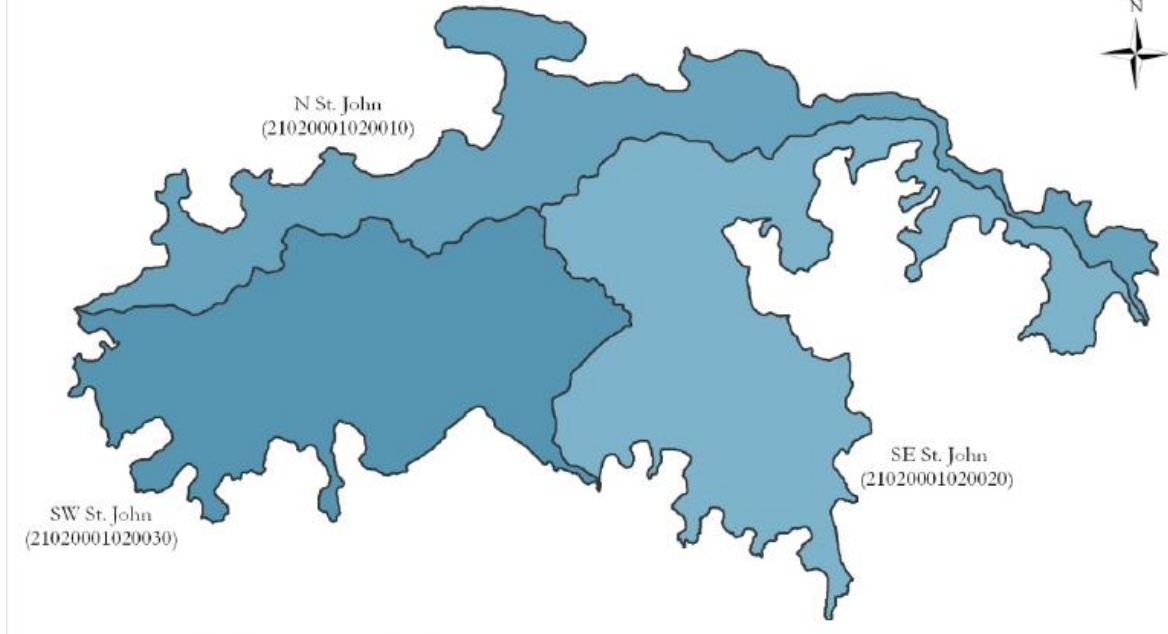
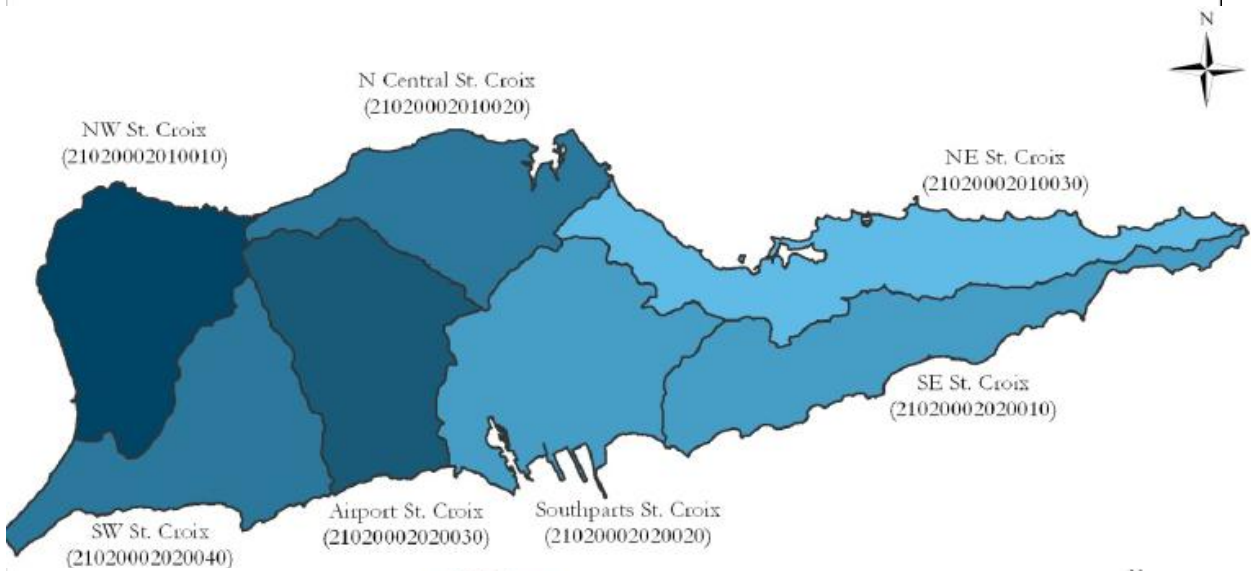
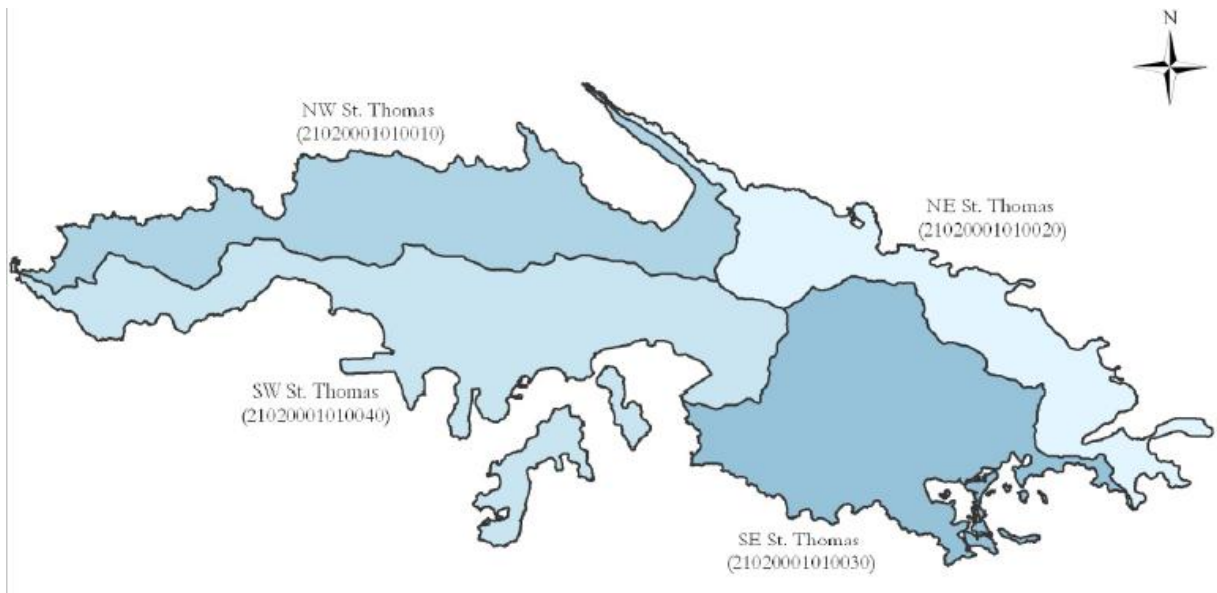

Other Selected Pacific Islands

Stormwater Standards

The 2010 *Palau Stormwater Management Manual* established required sizing criteria for water quality, channel protection, recharge, and overbank flood protection as a function of geology, land use, and resource quality (see table below). Requirements for other Pacific Islands were not investigated at this time.

Criteria	Requirement										
Recharge (Re_v)	<p><u>Limestone-Dominated Regions:</u></p> <p>$Re_v = (1.2 \text{ in.}) (A) (I)/12$ expressed in acre-feet where: I = Impervious area percentage of site area (decimal) A = Site area (acres)</p> <p><u>Volcanic-Dominated Regions:</u></p> <p>$Re_v = (F) (A) (I)/12$ expressed in acre-feet where: I = Impervious area percentage of site area (decimal) A = Site area (acres)</p> <table border="1"> <thead> <tr> <th>Hydrologic Soil Group</th> <th>Annual Recharge Volume Factor (F)</th> </tr> </thead> <tbody> <tr> <td>A</td> <td>0.46 inches</td> </tr> <tr> <td>B</td> <td>0.27 inches</td> </tr> <tr> <td>C</td> <td>0.13 inches</td> </tr> <tr> <td>D</td> <td>0.06 inches</td> </tr> </tbody> </table> <p>Note: Stormwater runoff from hotspots should not infiltrate into groundwater without appropriate pretreatment equivalent to 100% of the water quality volume</p>	Hydrologic Soil Group	Annual Recharge Volume Factor (F)	A	0.46 inches	B	0.27 inches	C	0.13 inches	D	0.06 inches
Hydrologic Soil Group	Annual Recharge Volume Factor (F)										
A	0.46 inches										
B	0.27 inches										
C	0.13 inches										
D	0.06 inches										
Water Quality (WQ_v)	<p><u>90% Rule (Discharge to High Quality Waters & Hotspot Land Uses):</u></p> <p>$WQ_v = [(P)(A)(I)] / 12$ expressed in acre-feet where: P = 1.2 inches I = Impervious area percentage of site area (decimal) A = Site area (acres)</p> <p><u>80% Rule (Discharge to Moderate Quality Waters):</u></p> <p>$WQ_v = [(P)(A)(I)] / 12$ expressed in acre-feet where: P = 0.7 inches I = Impervious area percentage of site area (decimal) A = Site area (acres)</p> <p>Note: Minimum $WQ_v = 0.0167\text{ft}^*(A)$ in acre-feet (or 0.2 watershed inches)</p>										
Channel Protection (Cp_v)	$Cp_v = 24$ hours extended detention of post-developed 1-year, 24-hour rainfall event (5.8 inches).										
Overbank Flood Control (Q_{p-25})	Control the peak discharge from the 25-year, 24-hour storm (12.4 inches) to 25-year pre-development rates.										

Annual Precipitation

The mean annual precipitation maps for Kosrae, Palau, and Pohnpei, are derived from Oregon State University Climate Center (2007) using partially gridded annual precipitation for the climatological period of 1971-2000. (www.prism.oregonstate.edu/products/pacisl.phtml).

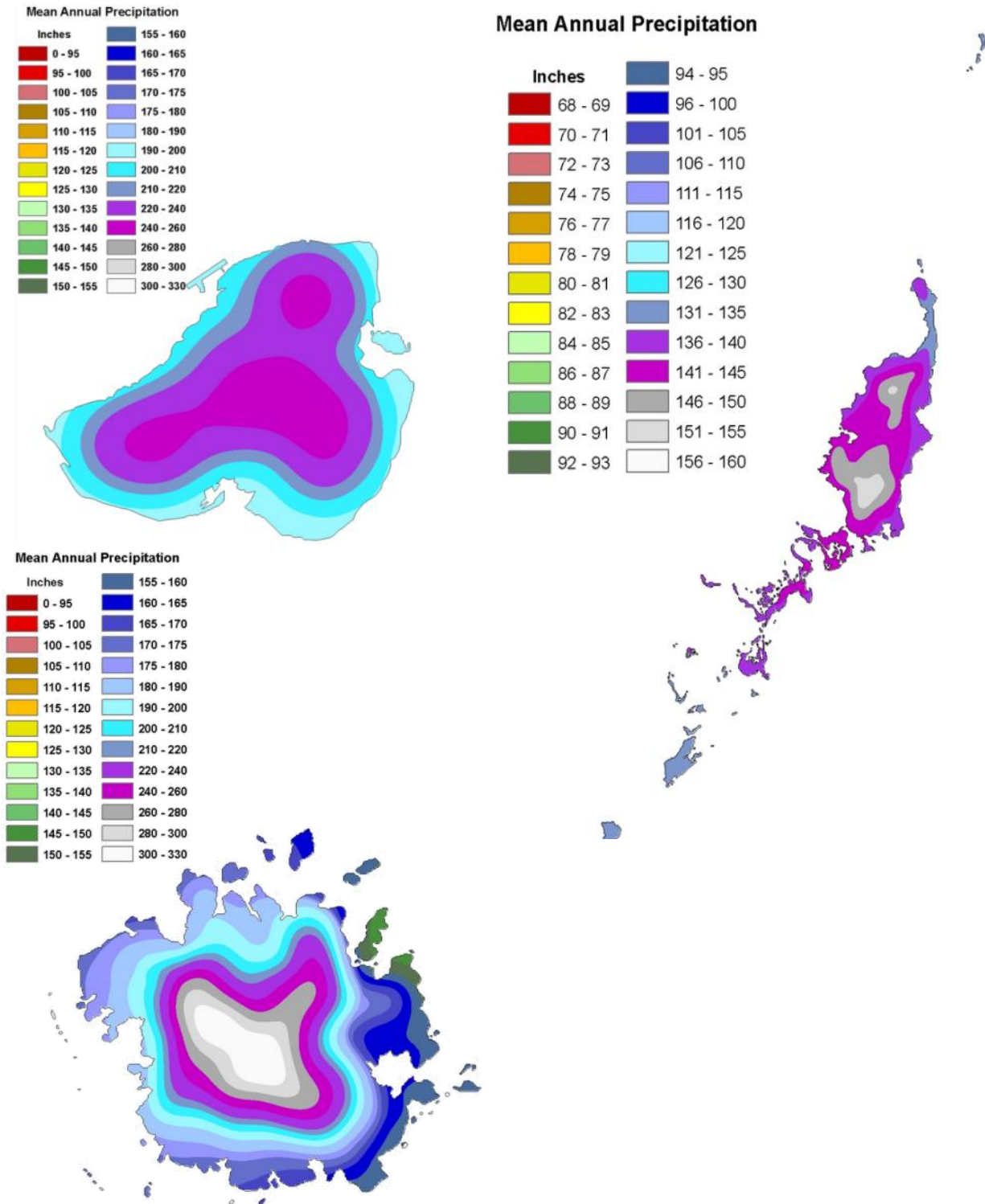

Rainfall Frequency Maps

The following map excerpts from NOAA Atlas 14, Vol. 5, Version 3, 2011 (online: http://hdsc.nws.noaa.gov/hdsc/pfds/pfds_maps.html) show average rainfall depths for selected recurrence intervals over a 24-hour duration for Pohnpei, Palau, Yap, and Kosrae (not to scale).

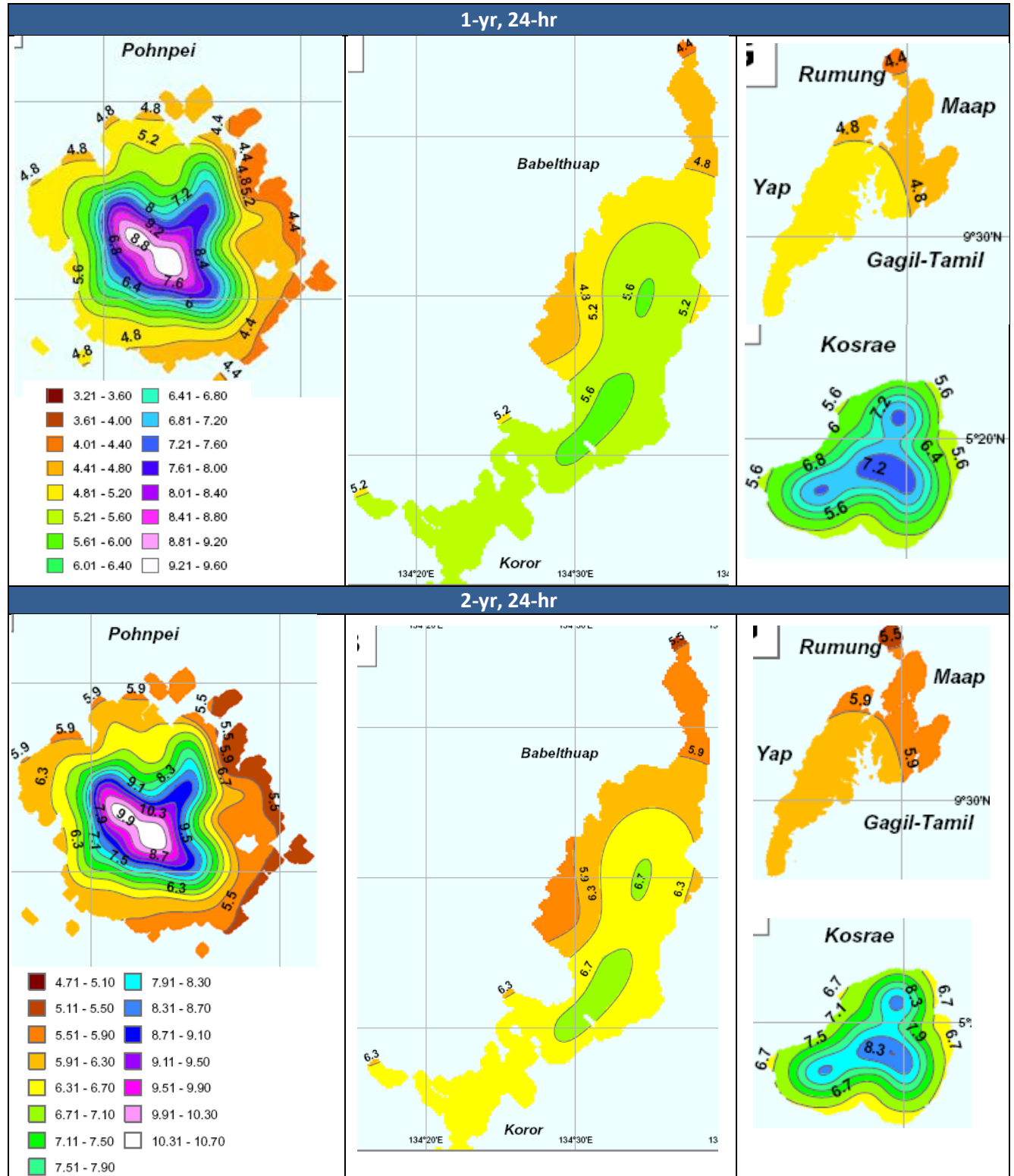

10-yr, 24-hr

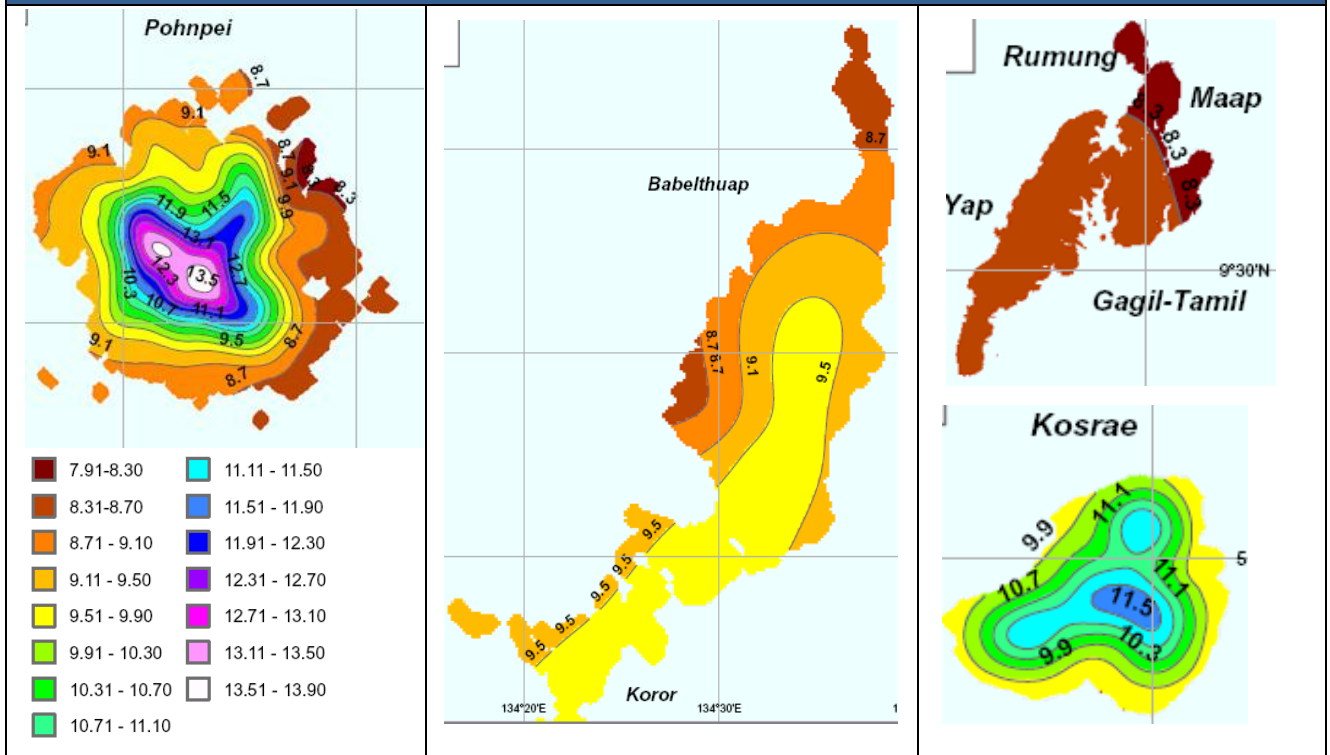

25-yr, 24-hr

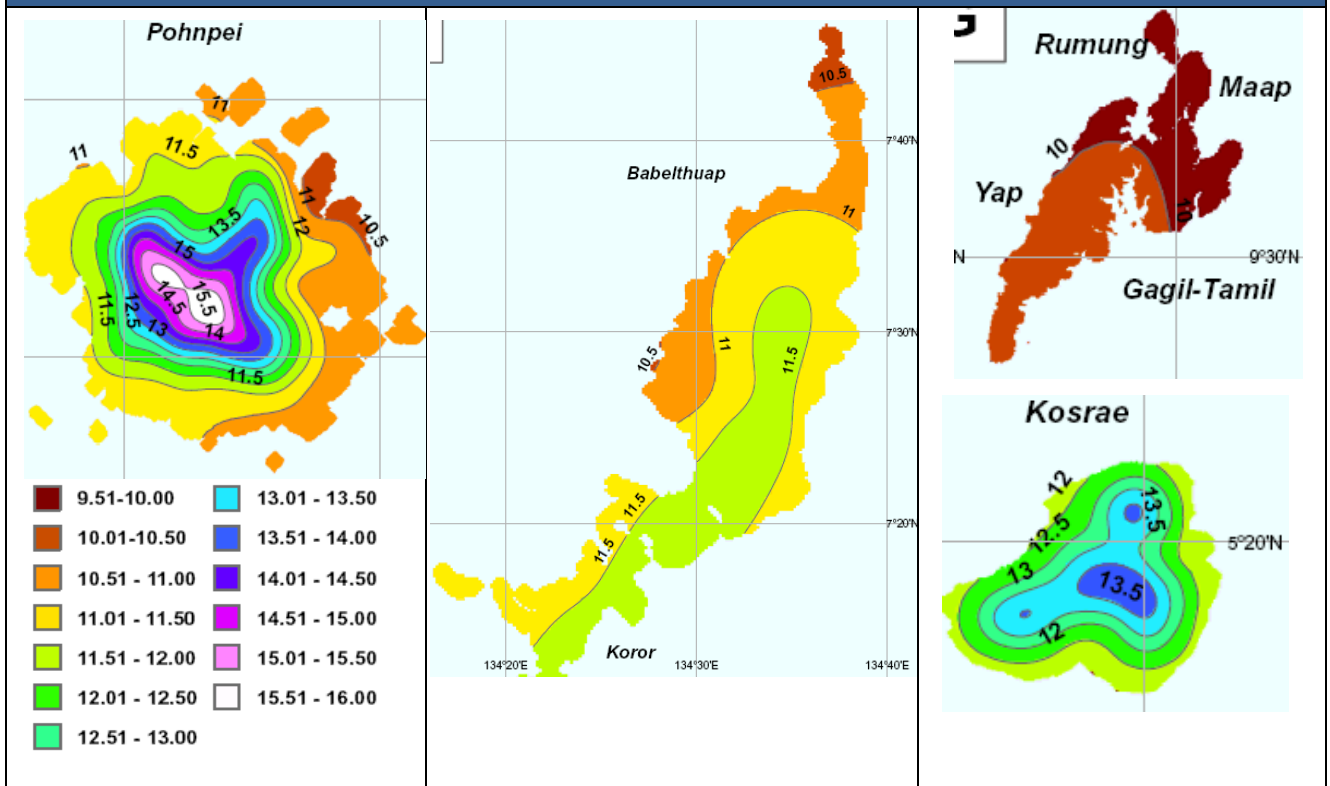

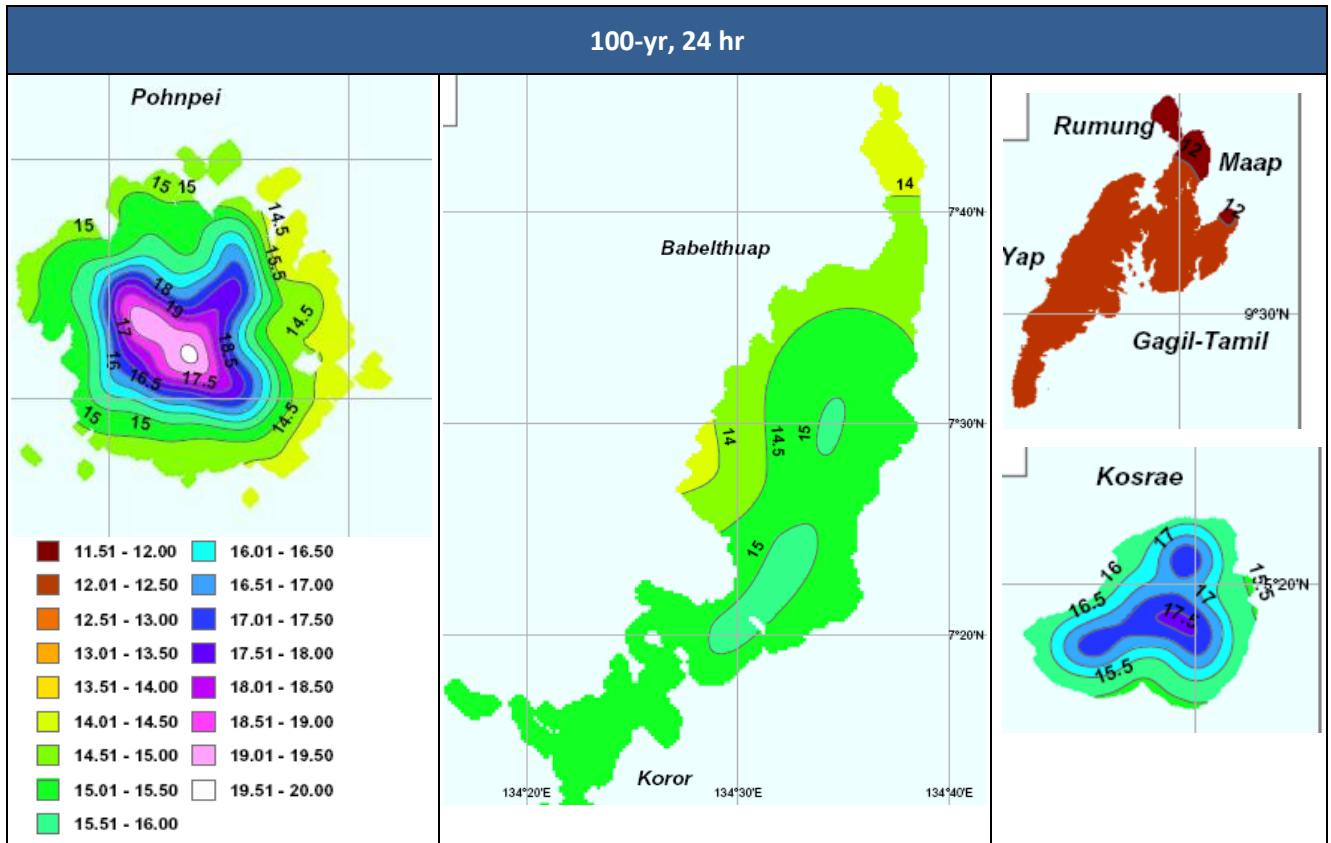

Rainfall Analysis

For Palau's stormwater manual, the highest-resolution rainfall data available is daily rainfall records for the USGS Airai Rain Gauge in Airai State (USGS site identification number 22523307), for a six-year period covering all of 1996, 1999, and the period of 2000 through 2003. This data was analyzed and plotted using a spreadsheet program to obtain a similar output as used for the CNMI and Guam Stormwater Manual. Palau adopted a water quality volume equal to the 80% and 90% of all daily rainfall totals fall. This method may actually result in a more conservative design standard than that used for the Guam and CNMI Manual, though for Palau, it resulted in slightly smaller design storm depths. The recharge volume adopted is equal to the 90% capture water quality volume.

Analysis of Palau Daily Rainfall Data used to determine Water Quality Criteria

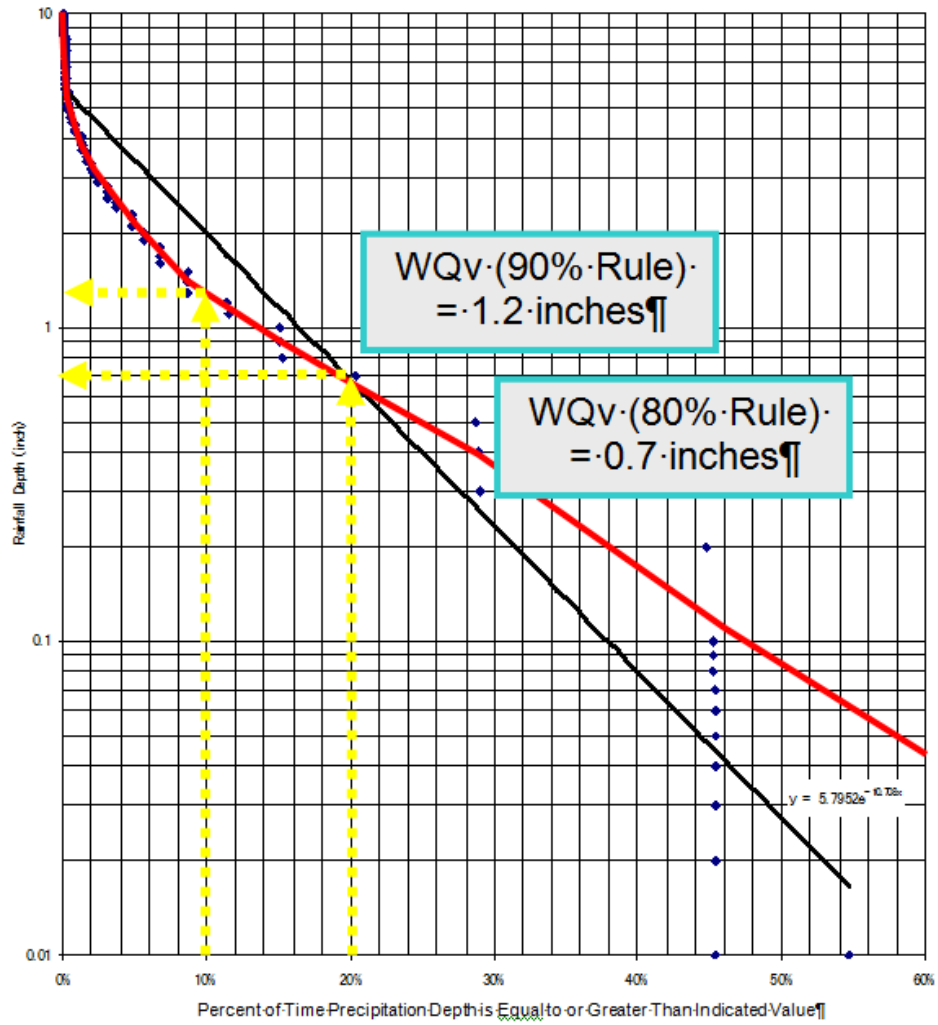

Annual rainfall captured as a function of design precipitation event

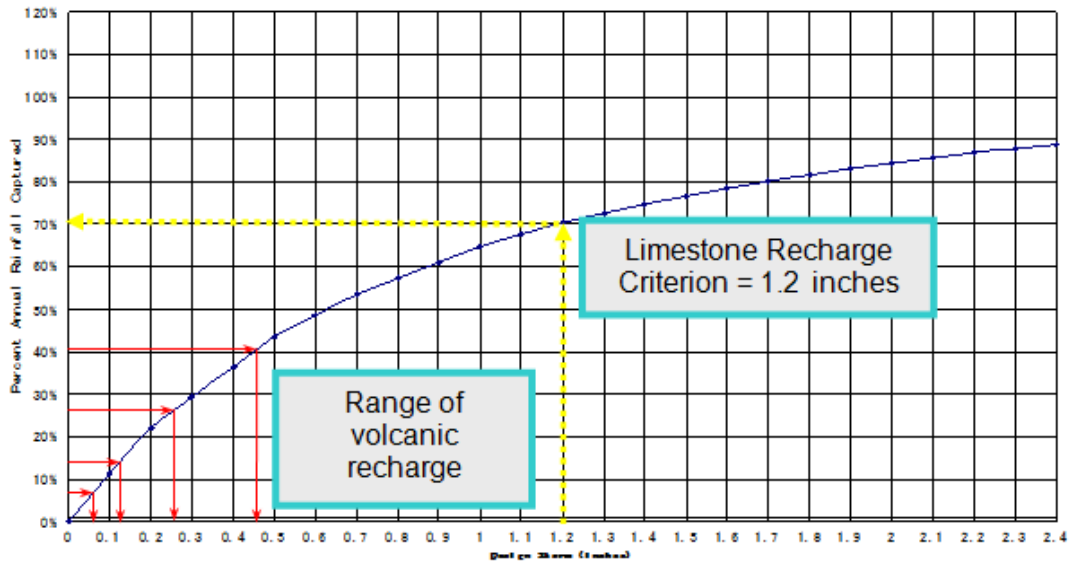
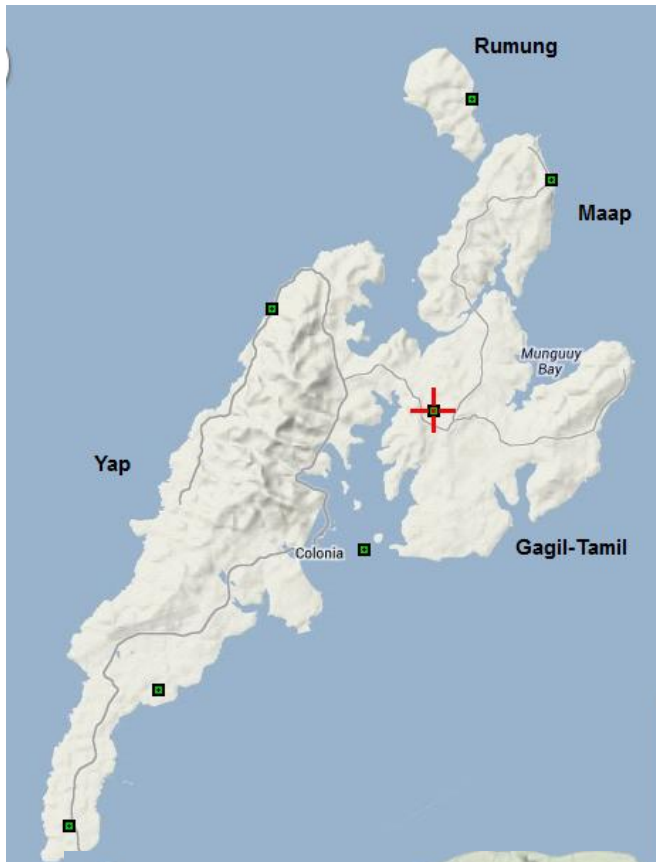

Table 3-2M. Partial duration rainfall for Koror (914351), Palau

Return Period	60-min	3-hour	6-hour	12-hour	24-hour	48-hour	72-hour
1	1.90	3.22	4.19	5.09	5.80	6.95	7.72
2	2.22	3.84	4.88	6.14	7.22	8.56	9.35
5	2.65	4.51	5.71	7.52	9.08	10.69	11.51
10	2.97	5.27	6.29	8.57	10.50	12.30	13.14
25	3.40	6.09	7.01	9.96	12.37	14.43	15.29
50	3.73	6.71	7.61	11.00	13.78	16.04	16.92
100	4.05	7.34	8.22	12.05	15.19	17.65	18.55
200	4.37	7.95	8.82	13.10	16.61	19.26	20.18
500	4.80	8.76	9.63	14.48	18.48	21.38	22.33

Precipitation depths for selected Island rainfall gauge sites for a number of measured events are displayed here along with the 90th percentage and the 95th percentage events. See figure maps below to reference site locations.

Site	Average Rain Depth (inches)						
	PACRAIN			From NOAA PFDS			
	# Rain Events	90th Percentile Event	95th Percentile Event	1-yr, 24-hr	10-yr, 24-hr	25-yr, 24-hr	100-yr, 24-hr
Kosrae Airport, Kosrae				5.28 (4.38-6.23)	9.45 (7.76-11.2)	11.5 (9.40-13.8)	15.3 (12.2-18.6)
Republic of Palau, Koror	15475	1.5	2.18	5.59 (4.53-6.60)	9.65 (7.72-11.5)	11.6 (9.18-13.9)	15.0 (11.6-18.3)
Republic of Palau, Airai	976	2.32	3.09				
Tamil, Yap	4600	1.38	1.98	4.87 (3.65-6.30)	8.54 (6.34-11.1)	10.0 (7.38-13.2)	12.3 (8.89-16.4)
Near Kolonia, Pohnpei, WSO	17398	1.66	2.28	5.30 (4.39-6.25)	9.47 (7.78-11.3)	11.6 (9.41-13.9)	15.3 (12.2-18.6)
Near Chuuk, WSO (International Airport)	8729	1.48	2.14	5.28 (4.27-6.28)	9.34 (7.47-11.2)	11.3 (8.97-13.7)	14.9 (11.5-18.3)



station maps http://hdsc.nws.noaa.gov/hdsc/pfds/pfds_map_pi.html

Daily Rainfall Analysis Procedures

Where original analysis of publically-available rainfall datasets was conducted, the following methodology was followed. Since nearly all data are incomplete, no work was done in this analysis procedure to force data into a specific number of years or determine return period of a given rainfall event. All rainfall data for a given location were ranked based on number of events rather than total volume associated with an event (i.e. a 0.05 inch rain event may be more frequent but may not deliver as much total rain as a 0.08 in rain event). This means, all events are weighted equally rather than large storms being weighted more heavily. In a tropical system, the day-to-day rainfall tends to be small with several possibly very large storms.

Generic Analysis Procedure (refer to Figure A-1)

1. Collect daily rainfall (convert text files to Excel files, if needed). If hourly data are available, aggregate to daily.
2. Initially rank ALL events. All events less than 0.01 inches are included in the initial rank, but are blanked during the ranking process.
3. Rank events larger than 0.01 inches. This process ranks the results of step 2 (ranks the initial rank).
4. Divide the rank from step 3 by the total number of observations larger than 0.01 inches. This step gives the fraction of the particular event relative to all other events.
5. Round the percentage to two significant figures to allow indexing (without this step, this method may not automatically retrieve the value for the 90th percentile, as the nearest value may be 90.001, for example).
6. Index all results to allow searching of a particular event fraction (90th and 95th percentile).
7. Graph results of each dataset

Specific Analysis Example: Andersen Air Force Base on Guam

1. Collect Daily Rainfall Data (<http://pacrain.evac.ou.edu/>)
 - a. Request data and enter a set of latitude and longitude values to constrain the search to the area of interest and enter your email for delivery once the request has been finished
 - i. Latitude set of 13.5 and 13.62 degrees; longitude set of 144.88 and 144.96 degrees for this example
 - b. This comes in a .tar compressed file format, which requires decompressing with a tool like winzip or peazip before use
 - i. The uncompressed files will need additional uncompression as they are in a .gz file format. The same decompressing tool can be used to uncompress these files
 - c. As there were several datasets that were downloaded based on this query, open the "sites.txt" file and select the location name based on the specific latitude and longitude of Andersen Air Force Base (Latitude: 13.5833 degrees, Longitude: 144.9170 degrees). The site name is US14025.
 - d. Open this file with Microsoft Excel or other spreadsheet tool that will allow for data analysis
 - i. These data are comma delimited
 - ii. These data are presented in millimeters of rainfall, which can be converted to inches by dividing by 25.4. In this example this calculation was done in column E

and started in cell E2. The existing numbers were written over as they were not needed

- e. Start the analysis by initially ranking each event larger than 0.01 inches. In this example, this calculation was done in column F and started in cell F2
 - i. In Excel, this formula was used: =IF(E2>0.01,RANK.EQ(E2,\$E\$2:\$E\$17857,1),"")
 1. Where E2 is the first rainfall amount in the record (converted to inches) and the range \$E\$2:\$E\$17857 is the entire rainfall record (it ends on row 17857 in this example. This step will give an initial rank and exclude any values less than 0.01 inches.
- f. Finalize the ranking of events over 0.01 inches. In this example, the calculation was done in column G and started in cell G2
 - i. In Excel, this formula was used: =IF(F2="",0,RANK.EQ(F2,\$F\$2:\$F\$17857,1))
 1. Where F2 is the initial rank just assigned and the range \$F\$2:\$F\$17857 is the entire set of initial rankings
- g. Count the number of rain events larger than 0.01 inches. In this example, cell M2 was used to house this calculation
 - i. In Excel, this formula was used: =COUNTIFS(\$E\$2:\$E\$17857,">0.01")
 1. Again, range \$E\$2:\$E\$17857 is the rainfall record in inches
- h. Determine the fraction of the total rain events the rank in column G represents
 - i. In Excel, this formula was used: =G2/\$M\$2
 1. Where G2 is the final rank of a given rain event and \$M\$2 is the total number of rain events larger than 0.01 inches.
 2. Continue this calculation to the end of the dataset (row 17857)
- i. Round the fractions from the previous step to the nearest hundredth so you can search for a specific value
 - i. In Excel, this formula was used: =ROUND(H2,2)
 1. Where H2 was the fraction of total rain events represented by this event
- j. Lookup the rainfall fraction of interest
 - i. In this example, cell M4 was used for this value (0.9 = 90th percentile storm)
 - ii. In order to look the appropriate values up and return a rainfall amount, this formula was used in Excel: =AVERAGEIFS(\$D\$2:\$D\$17857,\$I\$2:\$I\$17857,M4)
 1. This function averages all rainfall amounts associated with the 90th percentile storm.
 2. In large datasets, this will encompass values associated with the 89.5th percentile to the 90.4th percentile.
 3. In some instances where rainfall data are scarce, this method will not produce a value, but an estimate can be made by averaging results from the next nearest values returning a result (89th percentile and the 91st percentile, for example)
- k. Plot data, if desired
 - i. This information can be plotted to show patterns in rainfall. Use an xy scatter plot with the event fraction (from step h above) on the x axis and the rainfall amount associated with that fraction (step d above)

Figure A-1. Example ranking of daily rainfall data to generate 90th and 95th percentile storms

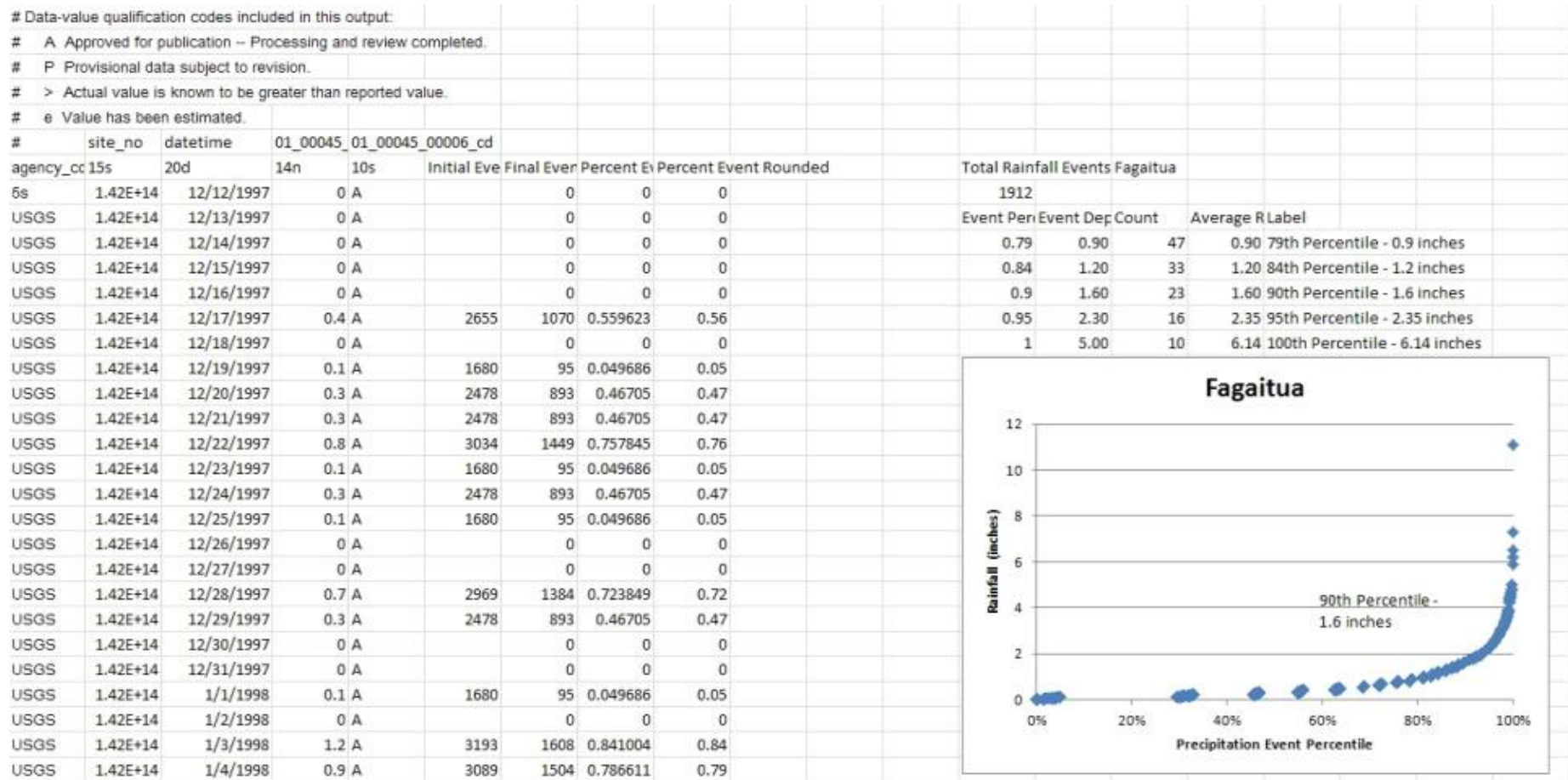

Appendix B

Island Plant Guide

Island Plants

One of the most difficult tasks when trying to adapt mainland vegetated BMPs for the islands is trying to determine which plants to use. While there has been research on plants native to the islands, and even plants that are good for stabilizing slopes, there has not yet been a lot of work looking specifically at tropical plants that work well for stormwater practices. A few good references that do exist are listed below – please contact the sources for more information on how the listed plants might work in your area/project:

- 2010 Island Stormwater Design Specifications: A Supplement to the 2006 CNMI & Guam Stormwater Design Manual
- 2010 NRCS Pacific Islands Area Vegetative Guide
- 2012 Rain Garden Plants booklet for 53 Hope and Carton Hill, St. Croix
- 2013 Hawai'i Residential Rain Garden Guide by Hui o Ko'olaupoko

In addition, there have been several recent rain gardens constructed that provide good case studies for which plants did and did not work in those specific locations. Project descriptions, planting plans, site photos, and lessons learned are provided below, along with contact information for the project.

CNMI Culture and History Museum Rain Garden – Garapan, Saipan

In 2012, a rain garden was constructed at the CNMI Culture and History Museum in Garapan as a demonstration project funded by the NOAA Coral Reef Conservation Program. This rain garden is located along the entrance drive/parking area for the museum in an area with little to no shade. The planting plan was put together by CNMI DEQ staff based on availability and what was known about the plants' tolerance to wet and dry conditions. Regular maintenance is performed at this site, and the various plant species have been monitored to determine what did well and what did not. The planting plan and photos of the site are included in Figures B1 and B2, and Table B1 describes how each plant fared with lessons learned in the comments column.

Figure B1. Planting Plan for the CNMI Culture and History Museum Rain Garden; plant selection was an experiment, influenced by availability and expected inundation patterns.

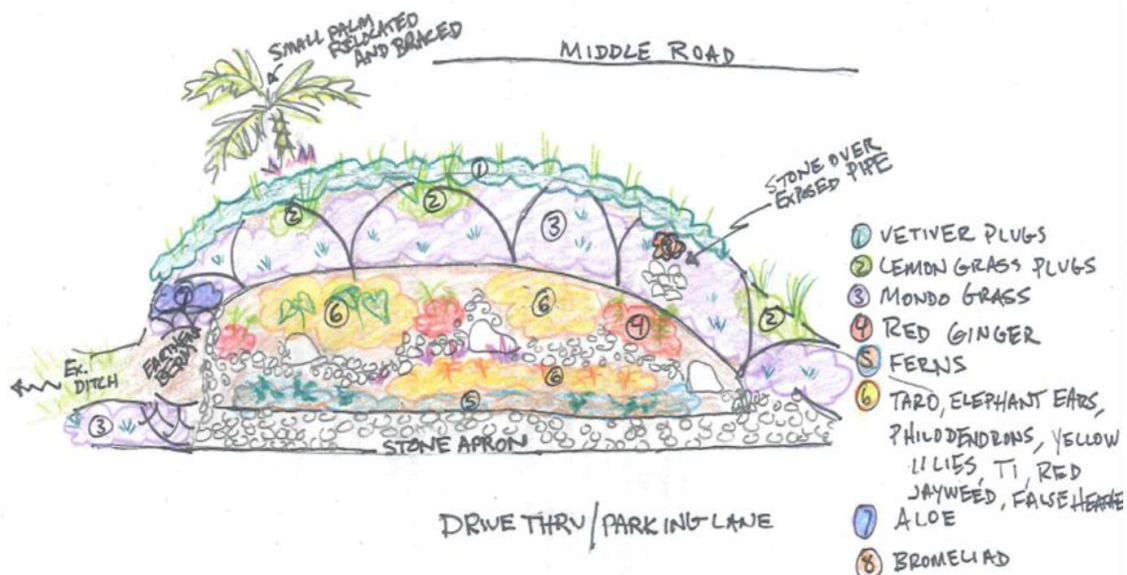

Figure B2. CNMI Museum rain garden immediately after planting in April 2012 (left photo); rain garden after maintenance in May 2013 (right photo).



Table B1. Plant List and Maintenance Information for CNMI Rain Garden (Okano, 2013)

Plant	Planted in April 2012	Survival by May 2013	Health *	Comments
Vetiver	2 large clumps-divided	All	VG	This was good for stabilizing the slope but it took over the upper portions of the rain garden. We had to prune the top and will also come back to thin it out during rainy season.
Taro	5+	6	G	Good, but some had to be transplanted because the vetiver was crowding it out. Not thriving as well after transplant, but looks like should come back.
Elephant Ear	5	5	VG	Had to prune it a little bit. Gets big in rainy season, but gets smaller during dry season.
Ferns	5	0	P	Probably succumbed to too much direct sun, may not be the best for slopes
Philodendron	5	2	F	
Red Jayweed	5	3	G/F	These did well but a few were accidentally mistaken for weeds and were pulled. They were re-planted but didn't come back as well as when first planted.
False Heather	10	0	P	These never took.
Mondo Grass	107	20	P	Stayed patchy, never grew together outside of a couple of clumps. Many were too shaded by the vetiver or overtaken by grass.
Red Ginger	10	4	F	The ones that survived look okay, one is even flowering.
Yellow Lilies	2	2	G	
Lemongrass	8	5 or 6	VG	
Aloe	4	1 or 2	P	These were also too shaded by the vetiver, had to transplant them. They are still struggling after the transplant.
Ti	10	10	VG	Grew fast and tall. Would be better in back than in front. Will prune during rainy season to keep shorter and blend better with the garden.
Ferns -laau	9	1 or 2	P	The garden is still too hot and dry. Even being in the 'wet' zone wasn't cool/wet enough.
Bromeliad	1	1	P	It is being taken over by the vetiver, too shaded.

* VG – Very Good, G – Good, F – Fair, P – Poor

For more information, contact:

Dana Okano

Coastal Management Specialist & Coral Management Liaison

NOAA Office of Ocean & Coastal Resource Management

CNMI Field Office

(670) 234-0005

Wahikuli Wayside Park Rain Garden – Maui, Hawai'i

This rain garden was described in detail in Chapter 3 on vegetated practices. The rain garden is located on the dry side of West Maui (but does receive frequent water from a nearby shower) and receives full sun. The planting plan for this rain garden was developed by Hui o Ko'olaupoko based on the plant list provided in the 2013 Hawai'i Residential Rain Garden Manual and is shown in Figure B3. A full 1-year monitoring report will be done for the plants next spring, but the photos in Figure B4 show that plant survival has been high at least through the summer.

Figure B3. Wahikuli rain garden planting plan

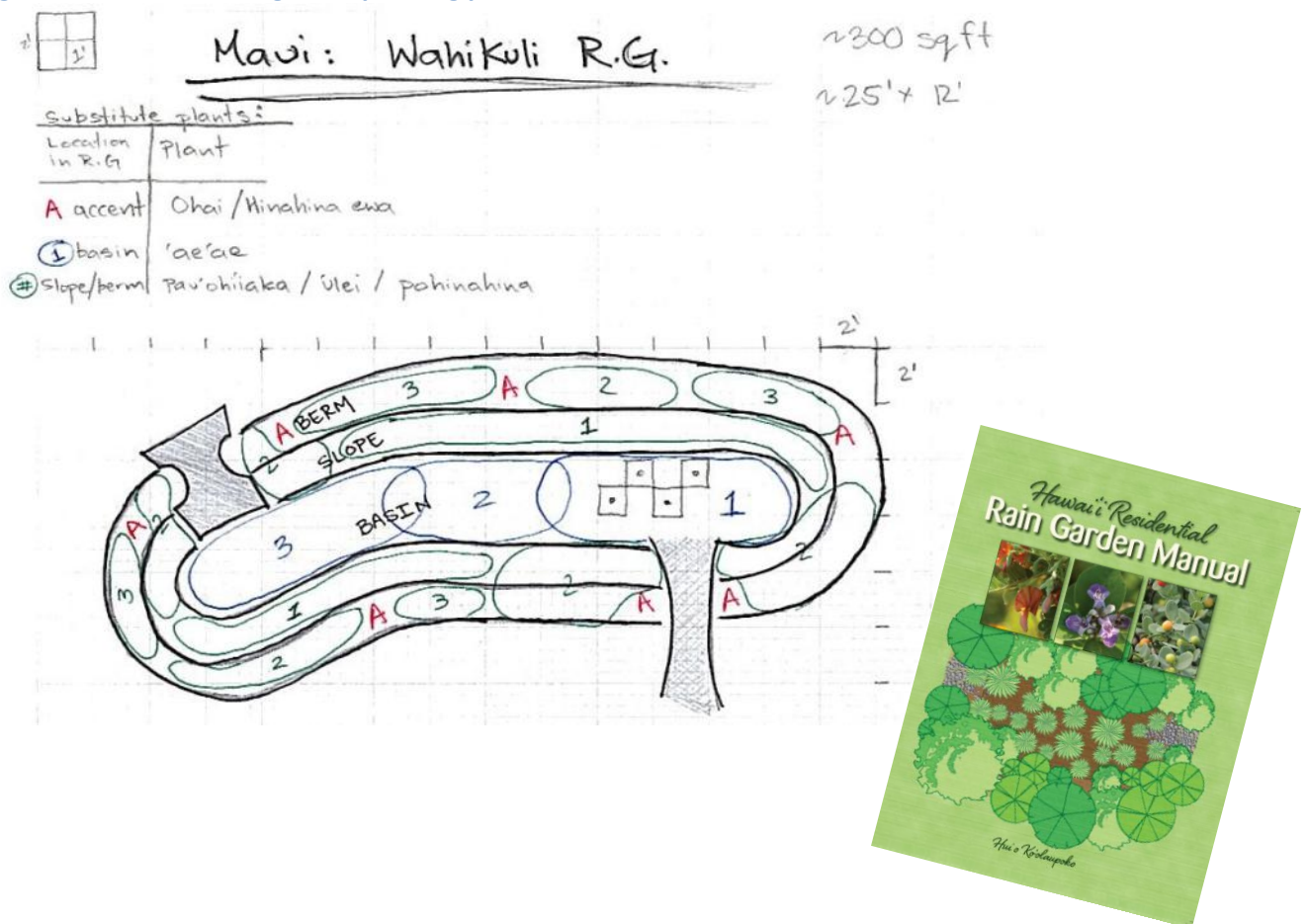

Figure B4. Wahikuli rain garden immediately after planting in March 2013 (left photo); rain garden in July 2013 (right photo).



For more information, contact:

Tova Callender

West Maui Watershed Coordinator

(808) 214-4239 www.westmauir2r.com

Hope and Carton Hill Residential Rain Garden – St. Croix, USVI

The Hope and Carton Hill rain garden is described in more detail in Chapter 3 on vegetated practices. This rain garden is located on the dry, East End of St. Croix in full sun on a residential property. The planting plan for this project was developed by local NRCS and St. Croix Environmental Association staff, as well as volunteers from the neighborhood based on available native plants and estimated tolerance to dry and wet conditions. The planting plan is shown in Figure B5. In addition, a rain garden plants booklet was compiled that describes and illustrates each plant; screenshots from the booklet are shown in Figure B6. A 1-year monitoring report was performed, with results listed in Table B2 below. In general, most of the plants thrived in this location as you can see in the photos in Figure B7, but some of the trees suffered from deer browsing.

For more information, contact:

Carol Cramer-Burke

St. Croix Environmental Association Program Director

(340) 773-1989

Figure B5. Planting Plan for St. Croix Rain Garden

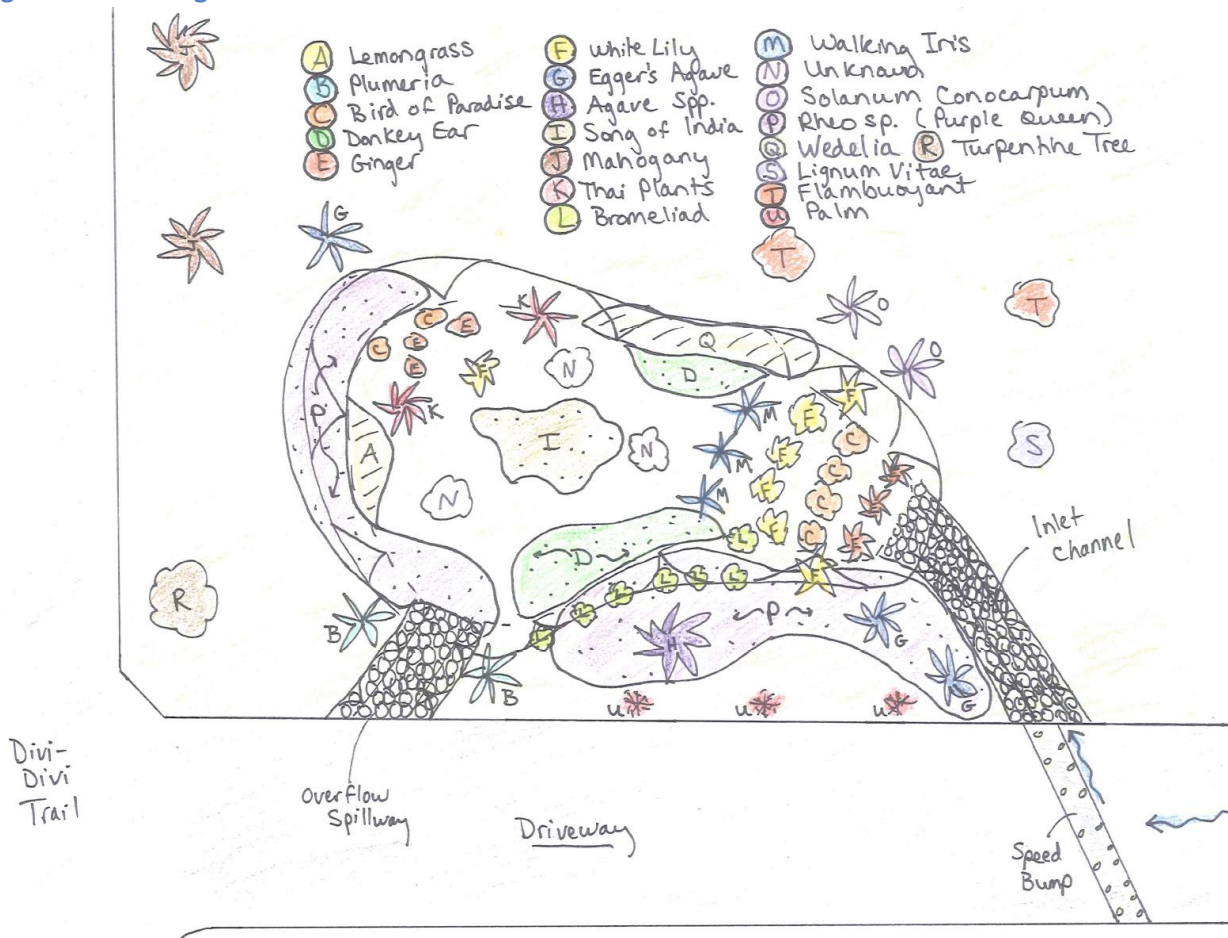

Figure B6. Rain Garden Plant Booklet for Hope and Carton Hill (Julie Wright, 2012)



Table B2. Plant list and maintenance information for St. Croix rain garden (Burke and Wright, 2013)

Plant Code	Plant	Health-November 2013*	Comments
A	Lemongrass	VG	Looks great
B	Plumeria	G-VG	Native one is doing better than non-native
C	Bird of Paradise	P	
D	Donkey Ear	P	Did not survive – probably would do better in wetter/shadier situation
E	Ginger	VG	Taking over a bit near inlet; need to thin back a bit
F	White Lily	P	Did not survive – probably would do better in wetter/shadier situation
G	Egger’s Agave	VG	
H	Agave Sp.	VG	
I	Song of India	VG	
J	Mahogany	G	Had some damage due to deer browsing, but surviving
K	Thai Plants	VG	
L	Bromeliad	P	Did not survive – probably would do better in wetter/shadier situation
M	Walking Iris	F	These are being squeezed out by the ginger. Would do better if the ginger were thinned back.
O	Solanum Conocarpum	VG	Looks great
P	Rheo sp.	VG	
Q	Wedelia	P	All are dead, but these were unrooted cuttings when planted
R	Turpentine Tree	G	Had some damage due to deer browsing, but surviving
S	Lignum Vitae	VG	
T	Flambuoyant	P	
U	Palm	G	

* VG – Very Good, G – Good, F – Fair, P – Poor

Figure B7. St. Croix rain garden immediately after planting in October 2012 (left photo); rain garden in November 2013 (right photo).



Appendix C

Compost and Soils

Soil Mixes and Compost

On the mainland, bioretentions and other filtering BMPs use an engineered soil mix to provide pollutant filtering and a media for plant growth. This mix is composed of construction sand (as much as 85%), a loamy sand soil, and organic material, such as compost. In some jurisdictions, however, finding good compost and silicon-based sand can be a real challenge, but plants seem to establish quickly given the right soils. Planting soil specifications provide enough organic material to adequately supply nutrients from natural cycling. The primary function of the media is to improve water quality. Adding fertilizers defeats, or at a minimum, impedes this goal and should only be done if needed to establish vegetation. This media is also used to enhance (or ensure) infiltration below the surface. In addition, some recent studies are showing that the use of compost can lead to elevated phosphorus concentrations at the outlet.

In areas dominated by limestone geology where coral is the stone of choice, using good compost and soil media is critical. Runoff should pass through the soil/compost layer before and/or after passing through the coral stone layer because:

- The coral stone has a relatively high pH, and metals may leach from runoff or the surrounding soil without some pH adjustment provided by the soil/compost.
- The stone is very coarse and, alone, would not provide adequate filtering of the runoff to provide the desired level of pollutant removal.
- The soil/compost also has a lower hydraulic conductivity (drains slower) than the coral stone, so more flow reduction will be achieved.

The soil should be a uniform mix, free of stones, debris, stumps, roots or other similar objects larger than two inches. No other materials or substances should be mixed or dumped within the BMP area that may be harmful to plant growth, or prove a hindrance to the planting or maintenance operations. The soil should be free of noxious weeds, seeds, and Rhino beetles (Pacific).

Once produced, the soil/compost mix should be placed within the BMP so that all runoff passes through the soil/compost layer before and/or after passing through stone layers. The soil/compost and stone layers should be separated by a layer of needle-punched, non-woven geotextile fabric to keep the soil/compost particles from migrating into the stone, while still allowing flow to pass between the layers.

In order for the compost to have the proper characteristics for pollutant removal, and to avoid leaching pollutants as stormwater passes through the compost, the following testing standards (**Tables C-1 and C-2**) are provided as guidelines (2006 CNMI and Guam Stormwater Manual, Virginia DCR, 2009; and 2010 Rhode Island Stormwater Manual). These standards can be modified as compost mixes are produced for actual Island BMP applications and some monitoring of the effluent is performed.

Sand	85-88%
Soil fines	8 to 12% (no more than 2% clay)
Organic Matter*	3 to 5%
* For bioretention applications with a soil depth of less than 4 feet, add 20% (by volume) of well-aged/well-aerated compost to the above planting soil mixture. Where soil fines content is less than 12%, add a corresponding % of compost.	

All bioretention facilities should have a minimum of one standard soil test for pH, phosphorus, and potassium and additional tests of organic matter, and soluble salts. Since different labs calibrate their testing equipment differently, all testing results should come from the same testing facility. Should the pH fall out of the acceptable range, it may be modified (higher) with lime/crushed coral or (lower) with iron sulfate plus sulfur.

Table C-2. Soil/Compost Standards	
pH	5.2 - 7.0
Bulk Density	1.6 to 1.7 g/cm ³
Phosphorus (P ₂ O ₅)	not to exceed 69 ppm
Carbon/Nitrogen Ratio (C/N)	> 25:1
Cation Exchange Capacity (CEC)	> 0.1 meq/g soil
soluble salts	not to exceed 500 ppm

Sand

Sand can be surprisingly hard to get. Preferred sand is means course-grained, volcanic or silica-based (Figure C-1). Limestone/ shell-based sand is ok, but should be course grained (meaning you can see and feel individual particles) and free of the fine, powder-like limestone dust that turns to cement when wet. Golf courses and landscaping companies may have imported sand (if needed). Dredge spoils may offer course-grained sand as well. Do not take sand from the beach.

Figure C-1. Range of sand options found in Guam and Saipan.



Compost

Various compost mixtures have been studied in the islands for the purposes of enhancing agricultural soils (Golabi, *et al.*, 2006, for example). Compost is typically produced from tree trimmings from roadsides, animal manure from farms, and wood chips from typhoon debris. Compost in the islands usually comes with a lot of surprises, ranging from unwanted seeds/weeds and in some cases Rhino Beetles! So making your own or knowing your source will be critical. The best compost is produced in piles with perforated pipes to supply air, and periodic mixing with a backhoe.

This same type of method would be appropriate for BMP applications, EXCEPT that the proportion of chicken, pig, and/or horse manure should be kept very low. Animal manure will increase the nutrient content of the compost to the level where nutrient leaching from the compost is likely, and bacteria



Bags of fine organic compost bought off the street from a backyard operation (full of weeds!) and rough-shredded mulch donated from the Lao Lao Golf Resort and CNMI Forestry Department were used for rain garden installation in Saipan.



There were some larger chunks in this shredded Maui mulch that had to be removed.



Compost material and shredded coconut palm mulch donated by local farmer and the Rhino Beetle Eradication project.



Finding the perfect compost on Hawaii is less difficult than in some of the other islands.



Mulch was treated with Rhino Beetle preventative.



Sand, mulch, and organic compost used at rain garden installation on St. Croix, USVI.

export may also be a concern. However, some organic content may be needed to promote growth of plants within bioretention areas.

In general, the following plant materials may be widely available and can be considered for use to produce Island BMP compost:

- Tangan-tangan (or tan tan) debris from roadsides – chipped or ground
- Coconut palms debris – chipped or ground
- Plant waste from farms
- A SMALL amount of well-composted animal manure from farms

The compost can be produced in actively-turned windrows, passively aerated windrows (perforated pipes), actively aerated windrows (forced air), bins, or silos (Golabi, *et al.*, composting (Hinman, 2009). It should have an earthy smell that is not sour, sweet, or ammonia-like; be brown to black in color and of mixed particle sizes with a crumbly texture. Compost should be produced at a stable temperature that does not get hot when re-wetted.

Mulch

The purpose of a mulch layer is to retain moisture and help reduce weeds. A finely shredded, well-aged organic mulch free of debris and weeds is preferred; a finely shredded, well-aged mulch may be accepted on a case-by-case basis. Wood chips will float and move to the perimeter of the bioretention area during a storm event and are not acceptable. Consideration should be given to other alternatives, such as coconut husks, stone or lava rock, or recycled rubber tires on a case-by-case basis depending on local accessibility and aesthetics. Special attention should be paid to longevity, floating, and possible leaching of dyes or chemicals.

Compaction

It is very important to minimize compaction of both the base of the bioretention area and the required backfill. When possible, use excavation hoes to remove original soil. If bioretention area is excavated using a loader, the contractor should use wide-track equipment, or light equipment with turf type tires. Use of equipment with narrow tracks or narrow tires, rubber tires with large lugs, or high pressure tires will cause excessive compaction resulting in reduced infiltration rates and storage volumes and is not acceptable. Compaction will significantly contribute to design failure. When backfilling facilities, place soil in lifts 12in or greater. Do not use heavy equipment within the bioretention basin. Heavy equipment can be used around the perimeter of the basin to supply soils and sand. Grade soil mixtures with light equipment such as a compact loader or a dozer/loader or by hand.

References

Golabi, M.H., P. Denney and C. Iyekar. *Composting of Disposal Organic Wastes: Resource Recovery for Agricultural Sustainability*. The Chinese Journal of Process Engineering. Vol. 6, No. 4, August 2006.

Hinman, C. *Bioretention Soil Mix Review and Recommendations for Western Washington*, WSU Extension, produced for Puget Sound Partnership, January 2009.

Virginia Department of Conservation & Recreation. *Stormwater Design Specification #9, Bioretention, Version 1.6*, September 30, 2009. Virginia Stormwater BMP Clearinghouse:
<http://www.vwrrc.vt.edu/SWC/index.html>

Rhode Island Department of Environmental Management and Coastal Resources Management Council.
December 2010. Rhode Island Stormwater Design and Installation Standards Manual.

CNMI Division of Environmental Quality and Guam Environmental Protection Agency. 2006. CNMI and
Guam Stormwater Management Manual.



This infiltrating landscape feature on the Big Island of Hawaii sports a combination of local lava rock and stone instead of typical mulch.



Readily-available coconut husks used in this church parking lot in American Samoa make an interesting aesthetic choice.



Coral stone was used in a linear bioretention in a corporate parking lot on Guam.

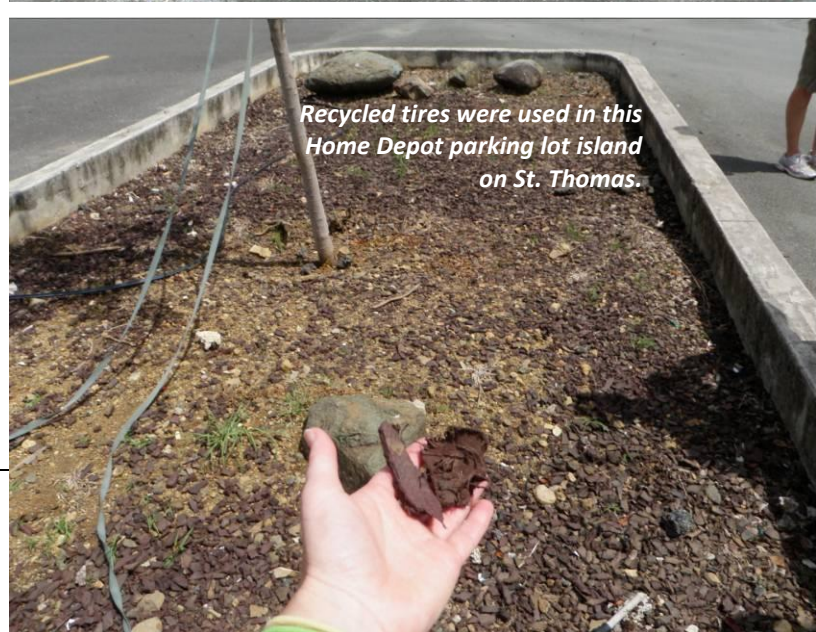

Recycled tires were used in this Home Depot parking lot island on St. Thomas.

Appendix D

Permeability Test

Field Test for Determining Hydraulic Conductivity in accordance with ASTM D5126-90 Method.

1. Saturated hydraulic conductivity rates should be determined in the field at the actual location and depth of the proposed practice.
2. The field method should consist of a constant or falling head permeability test performed in accordance with ASTM D5126-90 **“Standard Guide for Comparison of Field Methods for Determining Hydraulic Conductivity in the Vadose Zone”**
3. The Guelph Permeameter, the Amoozometer (also referred to as an Amoozegar Permeameter), and a falling head permeameter are all acceptable equipment to conduct the test. A double ring permeameter (also referred to as an infiltrometer) is not recommended for determining hydraulic conductivity in limestone deposits because of the difficulty in maintaining a seal in the shallower soils due to the presence of rock fragments.
4. Standard percolation testing procedures used for designing septic systems are not an acceptable method for determining design rates for stormwater management practices.