

NAVAER ISSUE OF 6 PAGES  
AIRPLANE CHARACTERISTICS & PERFORMANCE

BUREAU OF AERONAUTICS-NAVY DEPT.

COLUMN NUMBER		1	2	3	4
LOADING CONDITION		FIGHTER	FIGHTER	FIGHTER ONE TANK EXTERNAL	FIGHTER TWO TANKS EXTERNAL
GROSS WEIGHT	LBS.	7975	7975	8369	8762
EMPTY WEIGHT (ACTUAL)	LBS.	5895			
FUEL/OIL	GALS.	144/11	144/11	202/11	260/11
FIXED GUNS / AMMUNITION		6-.50 Cal./1440 rds.			
FLEXIBLE GUNS / AMMUNITION		None			
ENGINE POWER USED FOR PERFORMANCE		MILITARY	NORMAL	NORMAL	NORMAL
WING LOADING	LBS./SQ.FT.	30.7	30.7	32.2	33.7
POWER LOADING ①	LBS./BHP.	7.3	7.7	8.1	8.4
V-MAX. SEA LEVEL	MPH.	284	274	263	253
V-MAX. AIRPLANE CRIT. ALT.	MPH.	320/18800	320/18800	305/18800	294/18800
V-STALL. GROSS WEIGHT. ②	MPH.	81.2	81.2	83.2	85.1
V-STALL. WITHOUT FUEL ②	MPH.	76.7	76.7	77.0	77.1
TIME-TO-CLIMB -10000FT.-	MIN.	—	5.6	6.0	6.6
TIME-TO-CLIMB -20000FT.-	MIN.	—	12.4	13.6	15.2
SERVICE CEILING	FT.	34000	34000	32900	31800
TAKE-OFF DISTANCE -CALM-	FT.		640	733	842
TAKE-OFF DISTANCE -15 KN-	FT.		410	475	550
TAKE-OFF DISTANCE -25 KN-	FT.		278	330	390
TAKE-OFF TIME	SECONDS				
MAX. RANGE / V-AV. ③	ST. MI / MPH.		830/161	1050/157	1275/153
BOMBING RADIUS / V-AV.-20% R-	NMI / KN.				
BOMBING RADIUS / V-AV.-33% R-	NMI / KN.				
PATROL RADIUS / V-AV.-20% R-	NMI / KN.				
PATROL RADIUS / V-AV.-33% R-	NMI / KN.				
SCOUT. RADIUS	NMI.				
COMBAT RADIUS	NMI.		105	245	325
ENGINE / PROP GEAR RATIO		P.&W. R-1830-86 (3:2)			
ENGINE RATING BHP/RPM/ALT	NORMAL	1100/2550/S.L.-3300	MILITARY	1200/2700/S.L.-1800'	TAKE-OFF
		1080/2550/3800		1135/2700/3400	
		1090/2550/11300		1150/2700/11500	
		1030/2550/13000		1030/2700-2550/15000	
		1040/2550/18400		1040/2550/18400	
NOTE	STATUTE MILES USED-EXCEPT-RADIUS IS GIVEN IN NAUTICAL MILES & KNOTS. ① BHP AT MAX. CRIT. ALT. ② STALL-WITHOUT POWER ③ AT 5000' ALTITUDE				

	TANKAGE IN GALLONS	OIL	FUEL	OFFENSIVE ARMAMENT
FIXED	PROTECTED	11	144	
	UNPROTECTED			
	TOTAL-INCL. PROT.	11	144	
	INCREASE-REMOVED PROTECTION (Not removable)			
AUX.				
	DROPPABLE			
	DROPPABLE - Wings - 2 @ 58		116	
PROTECTED+UNPROTECTED+DROPPABLE.		11	260	

REMARKS- Model FM-1 has 4-.50 cal. guns and 1720 rds. ammunition, with gross weight 75 lbs. greater than F4F-4. The performance is based on the F4F-4 weights.

~~CONFIDENTIAL~~

NAVAER  
AIRPLANE CHARACTERISTICS & PERFORMANCE

BUREAU OF AERONAUTICS-NAVY DEPT.

COLUMN NUMBER				
LOADING CONDITION				
GROSS WEIGHT LBS.				
EMPTY WEIGHT LBS.				
FUEL/OIL GALS.				
FIXED GUNS / AMMUNITION				
FLEXIBLE GUNS / AMMUNITION				
ENGINE POWER USED FOR PERFORMANCE				
WING LOADING LBS/SQ.FT.				
POWER LOADING ① LBS/BHP.				
V-MAX. SEA LEVEL MPH.				
V-MAX. AIRPLANE CRIT. ALT. MPH.				
V-STALL. GROSS WEIGHT. ② MPH.				
V-STALL. WITHOUT FUEL ② MPH.				
TIME-TO-CLIMB -10000FT.- MIN.				
TIME-TO-CLIMB -20000FT.- MIN.				
SERVICE CEILING FT.				
TAKE-OFF DISTANCE -CALM- FT.				
TAKE-OFF DISTANCE -15 KN- FT.				
TAKE-OFF DISTANCE -25 KN- FT.				
TAKE-OFF TIME SECONDS.				
MAX. RANGE /V-AV. ③ ST. MI /MPH.				
BOMBING RADIUS /V-AV.-20% R- NMI /KN.				
BOMBING RADIUS /V-AV.-33% R- NMI /KN.				
PATROL RADIUS /V-AV.-20% R- NMI /KN.				
PATROL RADIUS /V-AV.-33% F- NMI /KN.				
SCOUT. RADIUS NMI.				
COMBAT RADIUS NMI.				

PERFORMANCE IS BASED ON- Flight Tests

RANGE & RADIUS ARE BASED ON Engine Requirement FUEL CONSUMPTION DATA INCREASED BY 15 PERCENT TO CONFORM WITH PAST EXPERIENCE.

Practical combat radius is based on 20 min. warm-up and idling; 1 min. take-off; 10 min. rendezvous at 60% normal sea level power (n.s.p.) and auto-rich; climb to 15000' at 60% n.s.p. and auto-lean unless auto-rich is required for cooling; cruise-out at 15000' at V for max. range and auto-lean; drop bombs and external tanks; 20 min. combat at 15000' at full military power; descent; cruise-back at sea-level at V for max. range and auto-lean; 60 min. rendezvous, landing and reserve at V for max. range and auto-lean. Radius includes distance covered in climb, but not in descent.

Contract Changes thru "R" and Service Changes thru #82 are incorporated.

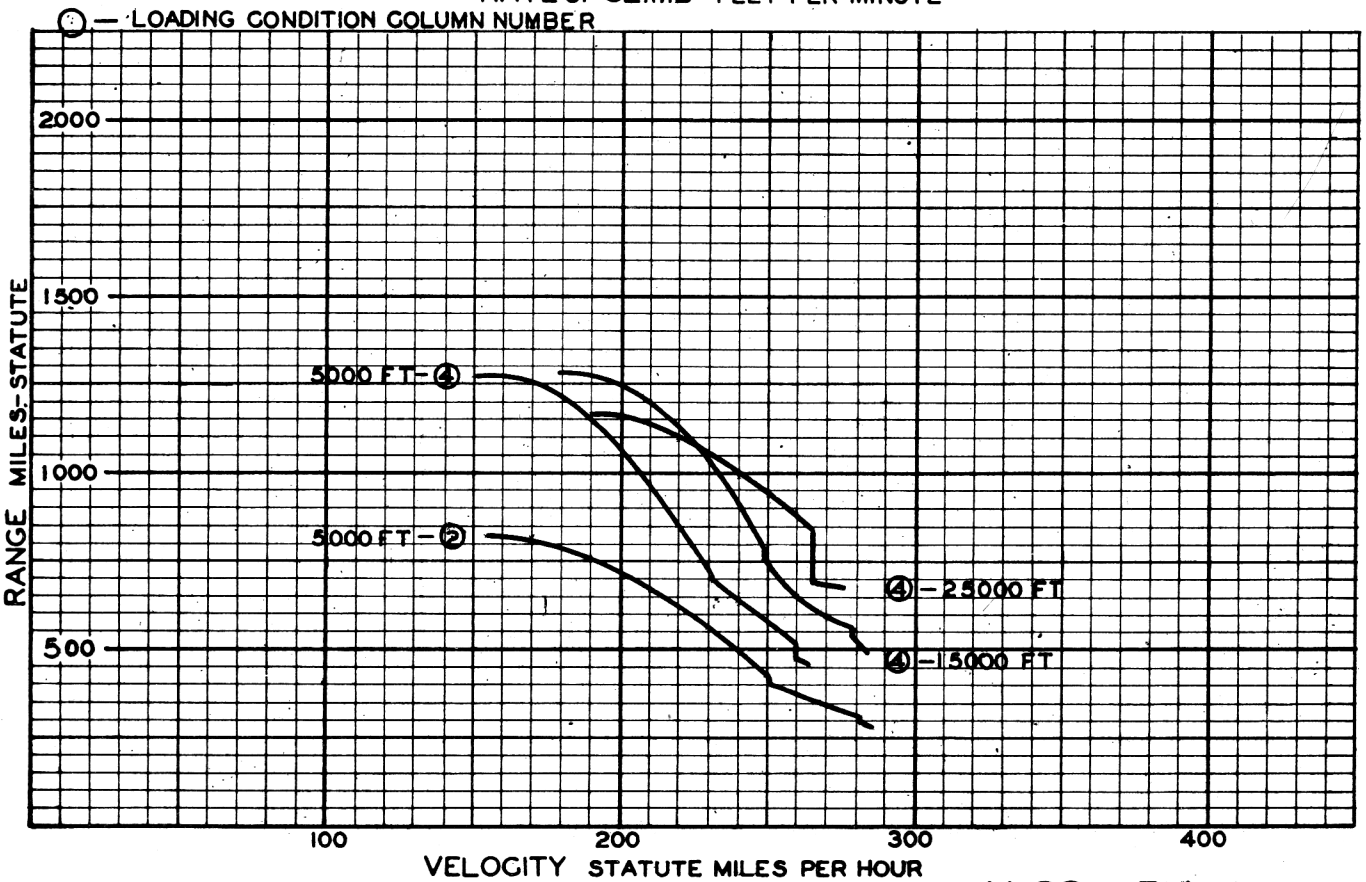
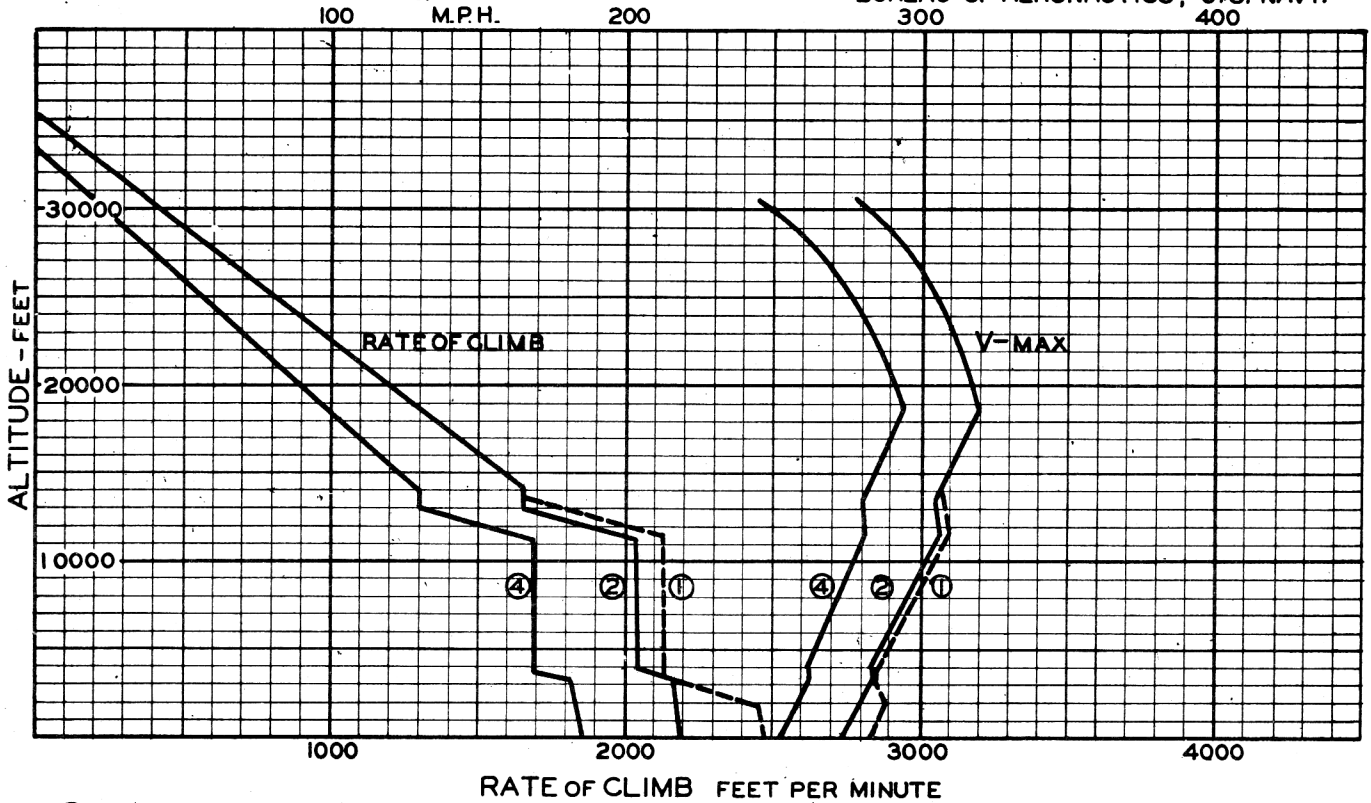

BUREAU OF AERONAUTICS  
NAVY DEPARTMENT

WING AREA-260 SQ. FT.  
WING SECTION-N.A.C.A. 23000  
M.A.C.-84.1"  
PROP-CURTISS ELECT. C.S.  
BLADE DESIGN NO.5I2-ICL-5-15

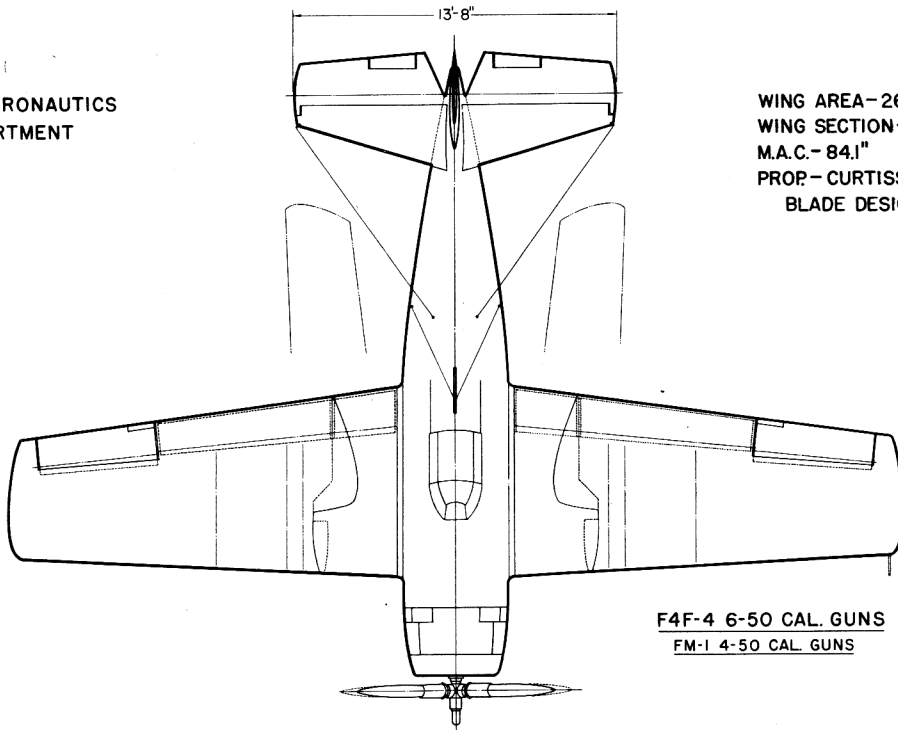

F4F-4 6-50 CAL. GUNS  
FM-1 4-50 CAL. GUNS

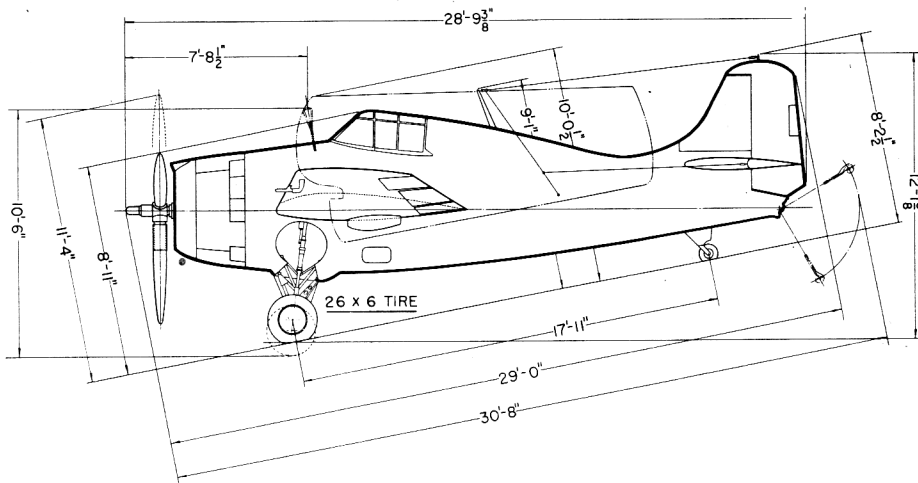
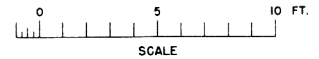
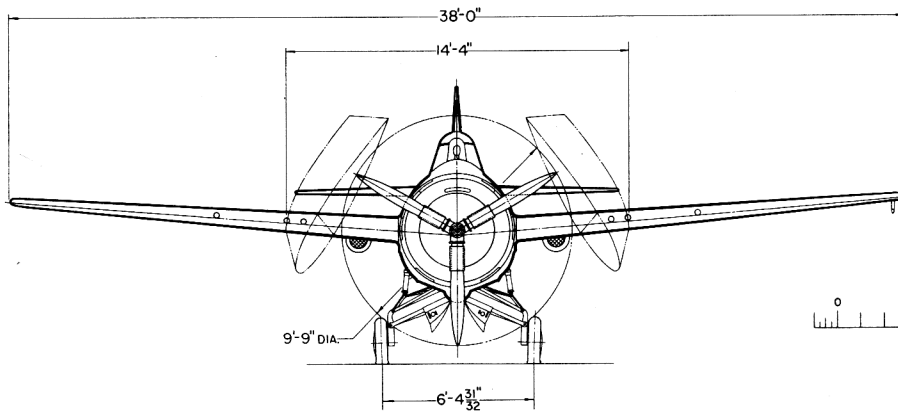

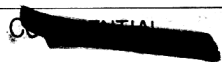

ALSO FM-1  
MODEL F4F-4



~~CONFIDENTIAL~~

MODEL F4F-4  
ALSO FM-1

BUREAU OF AERONAUTICS  
NAVY DEPARTMENT

-  BULLET RESISTANT GLASS ARMOR PLATE
-  SELF-SEALING TANKS
-  NON SELF-SEALING TANKS

PROTECTION

- |                       |          |
|-----------------------|----------|
| 1. OIL TANK           | 45 LBS.  |
| 2. PILOT FORWARD      | 25 LBS.  |
| 3. PILOT AFT          | 94 LBS.  |
| 4. SELF-SEALING CELLS | 126 LBS. |

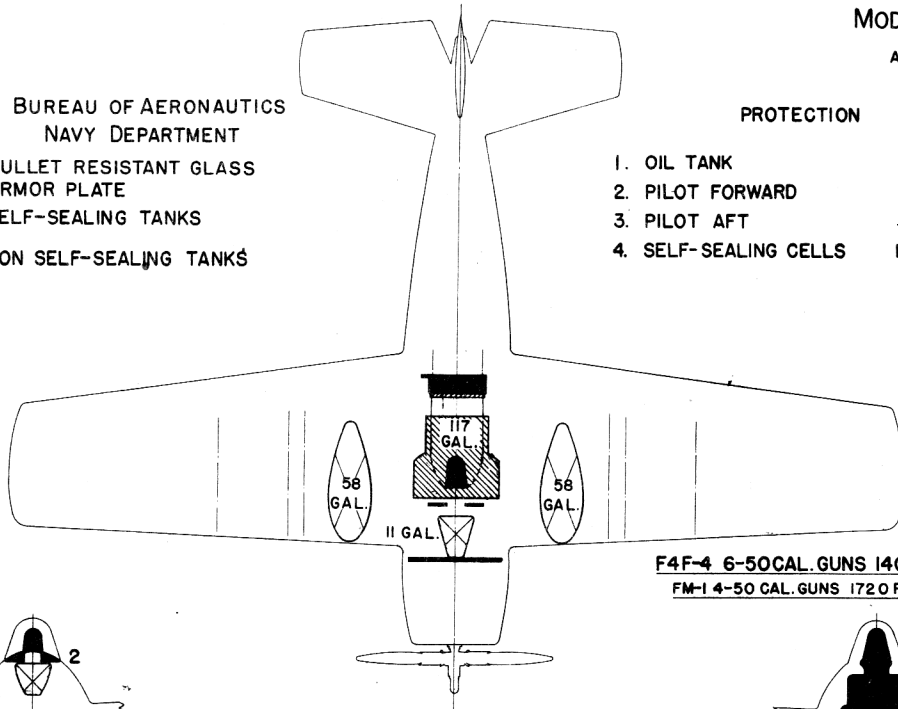

F4F-4 6-50CAL. GUNS 1400RDS. AMM.  
FM-1 4-50 CAL. GUNS 1720 RDS. AMM.

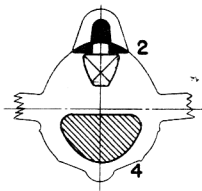

VIEW B TO C

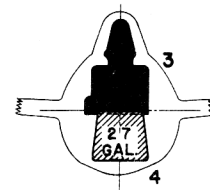

VIEW C

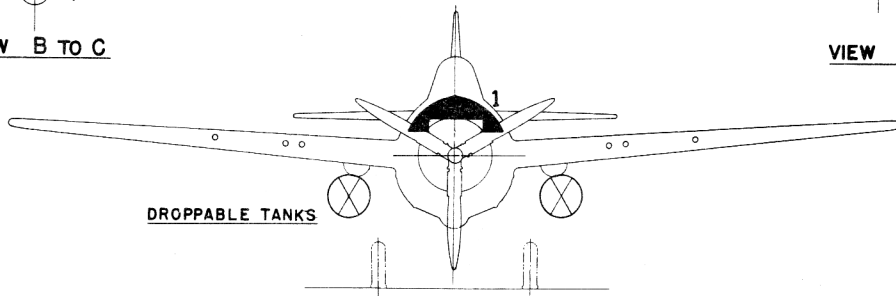

VIEW A TO B

DROPPABLE TANKS

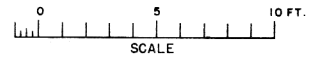
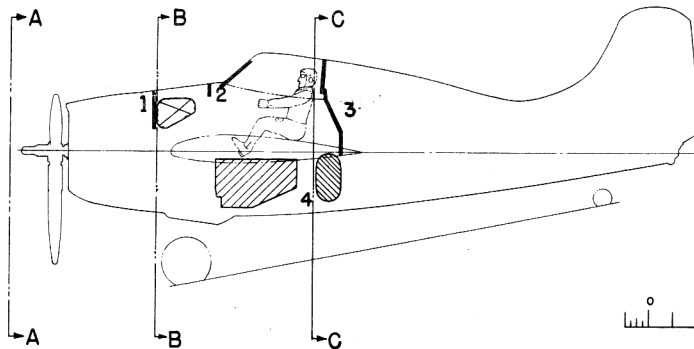

8