

OVERVIEW

Variable Speed Injection Circulators

Variable Speed Injection Mixing uses a circulator as a mixing device to maintain a specific temperature in the radiant loop. Typically used in radiant primary/secondary piping designs, the variable speed pump is installed in the “bridge” piping (see Figure 1) between the boiler loop and system loop. The speed of the circulator is modulated in order to inject different rates of hot water from the boiler loop into the cooler system return water. This allows for virtually any water temperature to be supplied to the heating system no matter the load applied within the zone.

A specific temperature can be selected directly on the PC board within the 00-VS variable speed “00” circulator or through the display menu on the PC705 and Radiant Mixing Block (RMB). Any time there is a demand signal, the pump will vary its speed to constantly maintain the selected temperature at the sensor location. Most boilers cannot operate at low temperatures, therefore the circulator can be modulated back in order to prevent the boiler from operating at cold temperatures. Multiple types of sensors (i.e. air, water, slab) can be used depending on the application (see Installation section).

The 00-VS can be either direct acting (speed increases on a temperature decrease) or reverse acting (speed increases on a temperature increase). A typical direct acting (limiting setpoint) application would be for boiler protection, where the 00-VS is installed on a bypass loop (see Installation diagram). If the return temperature starts to drop below the set temperature, then the speed of the pump will be increased, bypassing hot water to protect the boiler.

DESIGN

In order to properly accomplish and maintain a setpoint temperature, the following piping details should be considered.

When the injection pump is turned off, there must be no heat transfer from the boiler loop to the system loop. In order to avoid this unwanted heat transfer, primary/secondary piping techniques are used as shown in Figure 1.

This piping arrangement requires that the injection piping be at least one pipe diameter smaller than the piping of the boiler and system loops. There must be no more than 4 pipe diameters between the tees in the boiler and system loops (Note 1), in order to prevent ghost flow when the injection pump is off and the system or boiler pump is on. Also, there must be at least 6 pipe diameters of straight pipe on either side of the tees (Note 2), in order to prevent the momentum of water from the boiler and system loops from pushing flow through the injection loop. Finally, there should be a minimum of 1 foot drop in the injection loop in order to create a thermal trap (Note 3) in order to prevent convective heat transfer through the injection loop.

The Radiant Mixing Block (RMB) eliminates the need for the piping techniques as shown in Figure 1 (see page 2).

Benefits:

- Uses standard “00” circulators
- Maintains a specific temperature no matter the load
- Fully programmable
- Adjustable setpoint
- Simplified wiring
- Boiler Protection
- LED status panel or LCD display
- Match temperature delivery to design conditions
- Solid state microprocessor designed electronics available as an external control or integrated into a 00-VS circulator and Radiant Mixing Block

Products:

- PC705 - Variable Speed Injection Mixing Control
- 00-VS - Variable Speed Setpoint “00” Circulator
(available in all models 003-0014)
- RMB-1 - Radiant Mixing Block

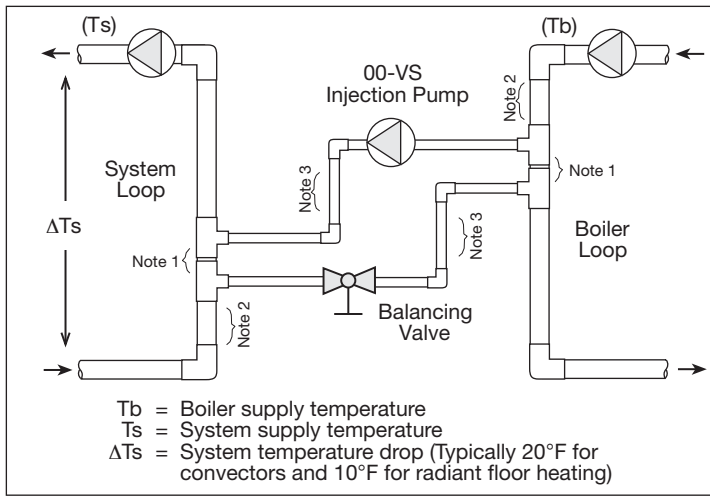

Figure 1

PUMP SIZING AND SELECTION

In order to properly size the 00-VS pump or the standard “00” circulator used in conjunction with the PC705, follow the design procedure below:

1. Determine the design operating temperatures of the system loop and boiler. (T_s and T_b from Figure 1.)
2. Determine the flow rate and design temperature drop (ΔT : Delta T) in the system loop. If one of these variables is unknown, use Equation 1 or 2 to determine the other variable.
3. Compute $T_b - T_s$. Look up the flow ratio on Figure 2.
- 4) The design injection flow rate for direct injection is calculated in Equation 3. If the injection flow rate is greater than 40 US GPM, a 3-way or 4-way valve may be required.

$$\text{Eq. 1: System Flow Rate (US GPM)} = \frac{\text{Design Heating Load (BTU/hr)}}{500 \times \Delta T_s (\text{°F})}$$

$$\text{Eq. 2: } \Delta T_s (\text{°F}) = \frac{\text{Design Heating Load (BTU/hr)}}{500 \times \text{System Flow Rate (US GPM)}}$$

$$\text{Eq. 3: Design Injection Flow Rate (US GPM)} = \text{System Flow Rate (US GPM)} \times \text{Flow Ratio}$$

- 5) Decide whether or not to include a balancing valve in the injection piping. A balancing valve allows adjustment when the injection pump is larger than needed. A balancing valve also provides the possibility of manual operation of the system by turning the injection pump fully on and adjusting the balancing valve to obtain the desired supply water temperature.
- 6) The injection pump size and model of Taco 00-VS pump to install can be looked up in Figure 3. Do not oversize the injection system. If the injection system is not able to provide enough heat, the boiler’s aquastat may be increased.

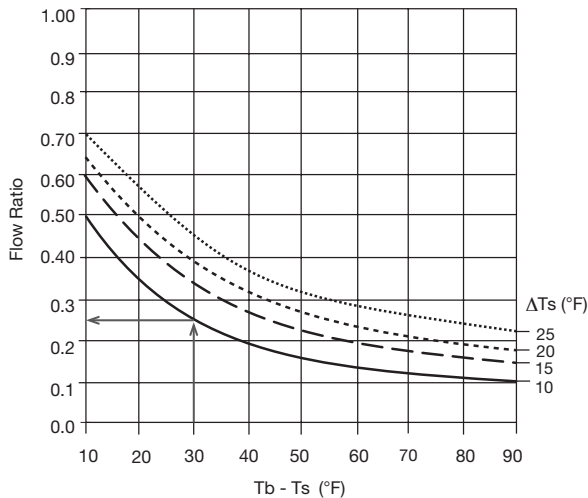

Figure 2

Design Injection Flow Rate (US GPM)	Balancing Valve Position (% open)	Balancing Valve Cv	Nominal Pipe Diameter (inches)	TACO Pump
1.5	30	2.4	0.5	003
2	40	4.5	0.5	003
3	40	4.5	0.5	006
4	100	15	0.5	006
7	40	6.9	0.75	007
8	50	10.4	0.75	007
9	30	5.76	1	007
12	40	10.8	1	007
14	40	10.8	1	0010
16	100	36	1	0010
20	50	19.8	1.25	0010
25	50	28.8	1.5	0010
30	30	18.2	2	0012
40	40	34.2	2	0012

This table assumes there are 5 feet of pipe, 4 elbows, and 4 branch tees of the listed diameter. Balancing valve is assumed to be a ball valve. The approximate Cv value is provided in order to allow for proper balancing device. Valve characteristics may vary for the same size and type of ball valve from manufacturer to manufacturer.

Figure 3

In order to ensure proper selection of the Radiant Mixing Block, follow the design procedure below:

1. Using the pump curve located below, ensure that the System Pump of the Radiant Mixing Block will provide adequate flow for the system in which it is to be installed.
2. Using the table or equation below, determine the required flow rate for the Injection Pump.
3. Using the pump curve located below, ensure that the Injection Pump of the Radiant Mixing Block will provide adequate flow for the system in which it is to be installed.

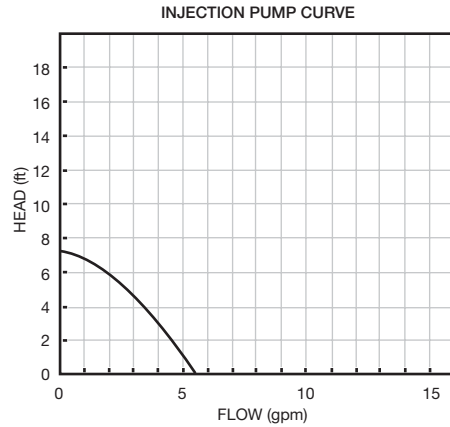
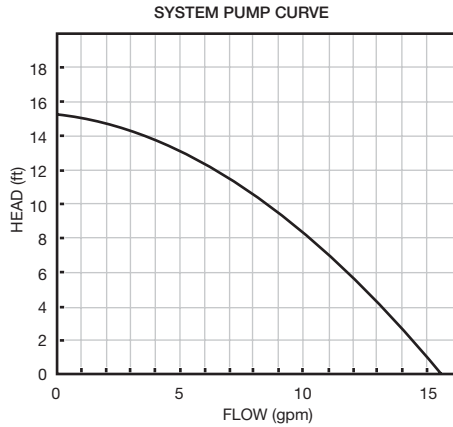

Required Injection Pump Flow Rate

T_b = Boiler Supply Temperature
 T_s = Radiant Supply Temperature

$$\text{Injection Flow Rate (GPM)} = \frac{\text{BTU's}}{(\text{T}_b - \text{T}_s) \times 500}$$

Required Injection Flow Rate (GPM)

T _b - T _s	BTU's x 1000					
	20	40	60	80	100	120
100	0.4	0.8	1.2	1.6	2.0	2.4
80	0.5	1.0	1.5	2.0	2.5	3.0
60	0.7	1.3	2.0	2.7	3.3	4.0
40	1.0	2.0	3.0	4.0	5.0	
20	2.0	4.0				

INSTALLATION

Variable Speed Setpoint "00" Circulator (00-VS)

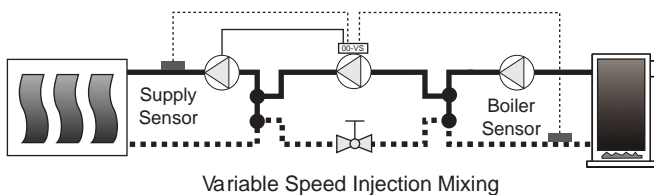

PC705 Injection Control with Standard "00" Circulator

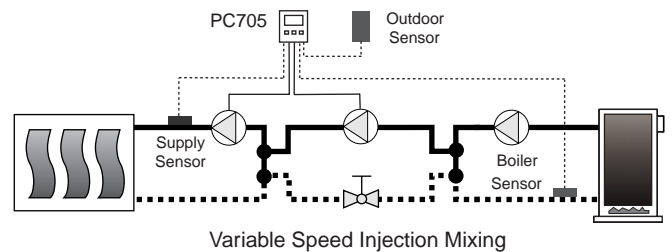

Variable Speed Setpoint "00" Circulator (00-VS)

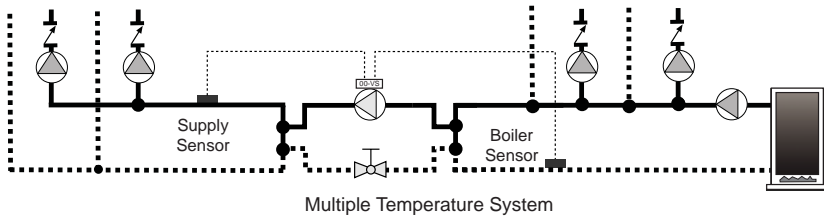

Radiant Mixing Block (RMB)

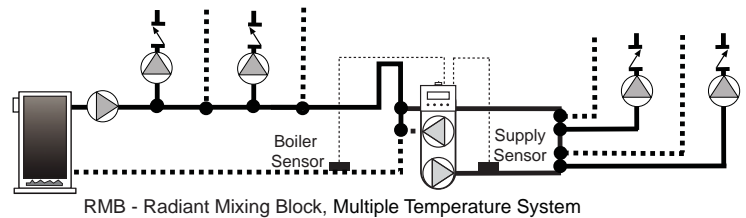
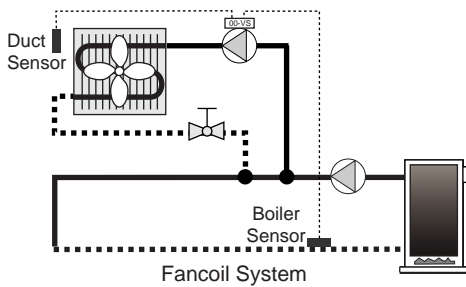
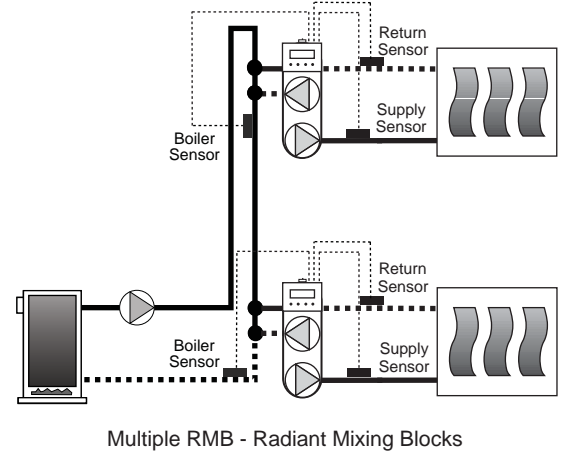
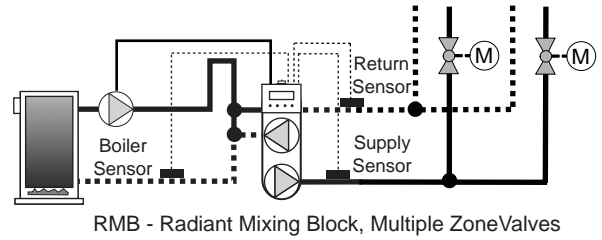
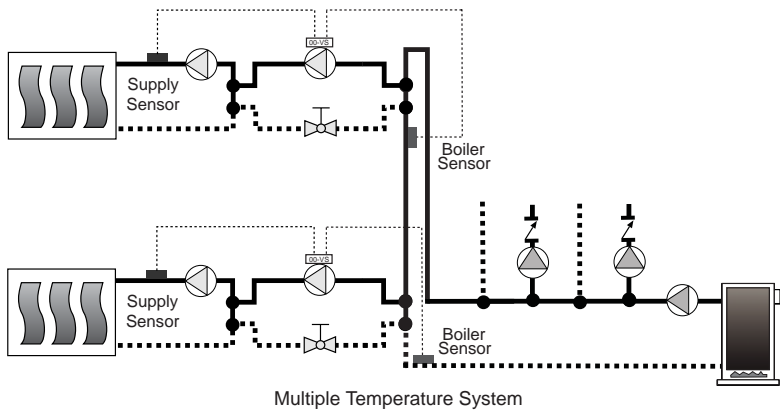
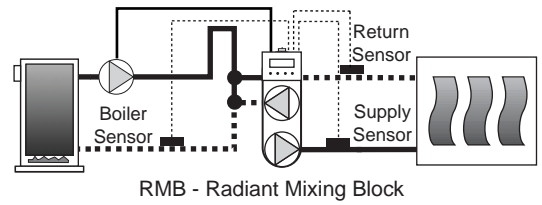

For installations where boiler protection is **NOT** required, the boiler sensor does not need to be installed.
For additional installation diagrams, refer to the appropriate product's Products & Application documentation.

Radiant Made Easy™

TACO, INC., 1160 Cranston Street, Cranston, RI 02920 Telephone: (401) 942-8000 FAX: (401) 942-2360.

TACO (Canada), Ltd., 6180 Ordan Drive, Mississauga, Ontario L5T 2B3. Telephone: 905/564-9422. FAX: 905/564-9436.

Visit our web site at: <http://www.taco-hvac.com>

Printed in USA

Copyright 2004

TACO, Inc.