

AD-A261 049



2

ARMY RESEARCH LABORATORY



Laser Ignition in Guns,
Howitzers and Tanks:
The LIGHT Program

Austin W. Barrows
Brad E. Forch
Richard A. Beyer
Arthur Cohen
Joyce E. Newberry

ARL-TR-62

February 1993

DTIC
ELECTE
MAR 09 1993
S E D

93-05016



4198

98 3 8 135

NOTICES

Destroy this report when it is no longer needed. DO NOT return it to the originator.

Additional copies of this report may be obtained from the National Technical Information Service, U.S. Department of Commerce, 5285 Port Royal Road, Springfield, VA 22161.

The findings of this report are not to be construed as an official Department of the Army position, unless so designated by other authorized documents.

The use of trade names or manufacturers' names in this report does not constitute indorsement of any commercial product.

REPORT DOCUMENTATION PAGE			Form Approved OMB No. 0704-0188	
Public reporting burden for this collection of information is estimated to average 1 hour per response, including the time for reviewing instructions, searching existing data sources, gathering and maintaining the data needed, and completing and reviewing the collection of information. Send comments regarding this burden estimate or any other aspect of this collection of information, including suggestions for reducing this burden, to Washington Headquarters Services, Directorate for Information Operations and Reports, 1215 Jefferson Davis Highway, Suite 1204, Arlington, VA 22202-4302, and to the Office of Management and Budget, Paperwork Reduction Project (0704-0188), Washington, DC 20503				
1. AGENCY USE ONLY (Leave blank)	2. REPORT DATE February 1993	3. REPORT TYPE AND DATES COVERED Final, Oct 90 - Apr 92		
4. TITLE AND SUBTITLE <u>Laser Ignition in Guns, Howitzers and Tanks: The LIGHT Program</u>			5. FUNDING NUMBERS PR: 1L162618AH80	
6. AUTHOR(S) Austin W. Barrows, Brad E. Forch, Richard A. Beyer, Arthur Cohen, and Joyce E. Newberry				
7. PERFORMING ORGANIZATION NAME(S) AND ADDRESS(ES)			8. PERFORMING ORGANIZATION REPORT NUMBER	
9. SPONSORING/MONITORING AGENCY NAME(S) AND ADDRESS(ES) U.S. Army Research Laboratory ATTN: AMSRL-OP-CI-B (Tech Lib) Aberdeen Proving Ground, MD 21005-5066			10. SPONSORING/MONITORING AGENCY REPORT NUMBER ARL-TR-62	
11. SUPPLEMENTARY NOTES				
12a. DISTRIBUTION / AVAILABILITY STATEMENT Approved for public release; distribution is unlimited.			12b. DISTRIBUTION CODE	
13. ABSTRACT (Maximum 200 words) <p>Recent advances in large-caliber gun propulsion systems have exacerbated the problems associated with reproducible and reliable ignition. The use of liquid propellant in the Advanced Field Artillery System (AFAS) 155-mm howitzer, multicomponent Unicharge in 155-mm howitzers and two-piece ammunition in the Advanced Tank Cannon System (ATACS) 140-mm tank gun introduce new constraints on the ability of conventional primers and igniter materials to achieve reliable ignition. In response to these challenges a new program entitled Laser Ignition in Guns, Howitzers and Tanks (LIGHT) has been developed. The goals of the program are two-fold and address the concepts of indirect and direct ignition of propelling charges. The short-term goal (indirect laser-based ignition) involves replacement of mechanically autoloading primers with laser-assisted ignition of igniter material within the propelling charge. The long-term goal (direct laser-based ignition) involves the elimination of all conventional primer and igniter materials from the ignition train and the use of laser radiation distributed through embedded optical fibers to simultaneously (isochronically) ignite the propelling charge. Anticipated benefits include decreased system vulnerability, a reduction in pressure waves for improved system safety and reliability and a potential improvement in performance through programmed and/or temperature compensating ignition.</p>				
14. SUBJECT TERMS laser ignition, ignition, solid propellants, lasers, optical fibers			15. NUMBER OF PAGES 39	
			16. PRICE CODE	
17. SECURITY CLASSIFICATION OF REPORT UNCLASSIFIED	18. SECURITY CLASSIFICATION OF THIS PAGE UNCLASSIFIED	19. SECURITY CLASSIFICATION OF ABSTRACT UNCLASSIFIED	20. LIMITATION OF ABSTRACT UL	

INTENTIONALLY LEFT BLANK.

TABLE OF CONTENTS

	<u>Page</u>
LIST OF FIGURES	v
ACKNOWLEDGMENTS	vii
1. INTRODUCTION	1
2. EXPERIMENTAL	4
3. DISCUSSION	6
3.1 Blackpowder Ignition (Unicharge)	6
3.2 Blackpowder Ignition (ATACS)	13
3.3 Direct Propellant Ignition	18
3.4 LP Ignition	20
3.5 Double-Laser Pulse Ignition	24
4. CONCLUSIONS	25
5. REFERENCES	27
DISTRIBUTION LIST	29

Accession For	
NTIS CRA&I	<input checked="" type="checkbox"/>
DTIC TAB	<input type="checkbox"/>
Unannounced	<input type="checkbox"/>
Justification	
By	
Distribution /	
Availability Codes	
Dist	Avail and/or Special
A-1	

DTIC QUALITY INSPECTED 1

INTENTIONALLY LEFT BLANK.

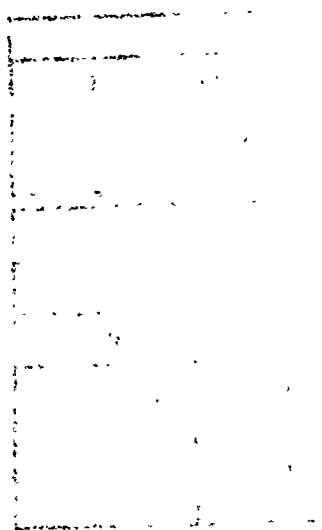

LIST OF FIGURES

<u>Figure</u>	<u>Page</u>
1. Laser Interaction With Propellant Surface	5
2. Pump-Probe Laser Experimental Setup	5
3. Unicharge Interior Ballistics Calculations	7
4. Solution to Unicharge Stand-Off Problem	7
5. Schematic of Unicharge Laser Ignition Concept	8
6. Transmission of Nd:Glass Laser Radiation Through a Mylar Window	9
7. Laser Ignition Test Setup	9
8. Trends Observed in Blackpowder Ignition	11
9. Effect of Laser Pulse Duration on Blackpowder Ignition Delay at Constant Laser Energy	11
10. Temporal Profiles of Laser Pulses (Top Drawing) and Effect of Increased Laser Energy on Ignition Delay at Constant Laser Pulse Width (Lower Drawing)	12
11. Light Emission From the Simultaneous Laser Ignition of Confined Blackpowder Igniters	14
12. Pressure-Time Curve for Laser Ignition of Confined Blackpowder Samples	14
13. BRL ATACS Laser Ignition Concepts	16
14. Characteristics of Tapered Optical Fibers	16
15. Tank Round With Embedded Optical Fiber Distribution System	17
16. Simultaneous Delivery of Two Laser Pulses for ATACS Ignition	17
17. Simultaneous Laser Ignition of Two ATACS Blackpowder Igniters Using Various Laser Pulse Widths (Through Optical Fibers)	19
18. Simultaneous Laser Ignition of Two 1-oz ATACS Blackpowder Igniters	19
19. Light Emission From the Laser Ignition of JA2 and M30 Propellants	20
20. Pressure-Time Curves for the Direct Laser Ignition of Confined M30 and XM43 Propellants	21

<u>Figure</u>	<u>Page</u>
21. BRL Conceptual Depiction of LP Gun With a Laser-Based Igniter	22
22. Schematic of BRL Laser-Based LP Igniter	23

ACKNOWLEDGMENTS

This work was supported by the Ballistic Research Laboratory (BRL), the Program Manager-Advanced Field Artillery System (PM-AFAS), and the Program Manager-Tank Main Armaments System (PM-TMAS). Purchase of data acquisition and processing equipment through the Productivity Capital Investment Program (PCIP) administered by David Ellis, BRL, is appreciated.

INTENTIONALLY LEFT BLANK.

1. INTRODUCTION

The Laser Ignition in Guns, Howitzers, and Tanks (LIGHT) Program was established at the Ballistic Research Laboratory (BRL), in part, as a result of an ignition concept which was discovered at BRL called *resonance laser microplasma ignition* (Forch and Miziolek 1986, 1987, 1991; Forch, Morris, and Miziolek 1990). It was found that reactive gaseous mixtures such as H_2/O_2 , D_2O_2 , and H_2/N_2O could be ignited into combustion very efficiently with laser energies less than 1 mJ at very specific laser wavelengths. A new laser ignition mechanism was formulated based upon the efficient and well-controlled resonant formation of laser-produced microplasmas. Briefly, if the laser is tuned to well-known absorption transitions of molecular or atomic species that are constituents of the gas mixture or are photolytically produced by the laser, then ionization and electron formation and amplification processes produce a microplasma which serves as an ignition source. When the laser is tuned off of the resonance absorption transitions of these species, it was found that as much as 60 times more laser energy was required for ignition. The attractive feature of this ignition source clearly lies in the efficiency of the process which may allow for the development of small, low-energy lasers to be used as igniters for energetic solid materials such as gun propellants. A laser source which is tuned to absorption transitions in solid materials or in pyrolysis gas produced at the solid-gas interface, could lead to efficient, low-energy ignition thresholds. Furthermore, the ability to directly ignite propellant beds could lead to the elimination of primers and igniters from the ignition train which would dramatically minimize vulnerability, simplify the ignition train, and facilitate the ignition of insensitive munitions which are inherently difficult to ignite.

There are several well-known laser ignition methods which include spark formation, photochemical ignition, resonant formation of microplasmas, and thermal heating. All of these ignition mechanisms are currently under evaluation for applications to the initiation of propellant beds in large-caliber guns. The overall goal within the LIGHT Program is to eliminate all primers and igniter material from the ignition train. Within the LIGHT Program, ignition has been categorized into two regimes, called *direct* and *indirect laser-based ignition*. The direct laser ignition concept (the long-term program goal) focuses on initiation of propellant beds via the interaction of laser light with the charge; no igniter material whatsoever is used to facilitate the ignition. Indirect laser ignition (the short-term program goal) involves the removal of current primers and igniter material from the ignition train in their present configurations within the munition. Here, the laser light is first transmitted to a sensitizer which is a small quantity of energetic material which then transfers the ignition stimulus to the propellant bed. Both laser ignition concepts involve the transfer of laser radiation into the gun through the use of optical fibers connected

through a breech window. An obvious important consideration is the transfer of the laser light through the gun breech. Concepts where a small optical window is incorporated into the breech have been developed and shown to be highly successful. The breech window must be composed of a material which will readily transmit the laser radiation with no optical damage and, in addition, withstand the high pressures and temperatures encountered with large-caliber guns. A suitable breech window material made from aluminum oxide (sapphire) easily satisfies these requirements. Synthetic sapphire is routinely used in high-pressure, hostile environments. In addition to the requirements of the window for robustness and high transmission at the laser wavelengths used, problems associated with contamination must also be addressed. The breech window may well survive a single initiation; however, combustion products and particulates (debris) may contaminate the window and reduce the transmission of the laser beam in subsequent firings. Repeated firings may produce a degree of contamination such that the transmitted laser energy is no longer sufficient for reliable ignition. Simple concepts have been developed where the breech window can be partially shielded from the combustion event and/or cleaned using a breech brush. It has been demonstrated that if the breech window is incorporated into a debris trap in an artillery gun, then contamination can be minimized. Although the window does indeed become somewhat obscured by particulates, a steady-state condition is achieved which inhibits further loss in transmission. BRL has proposed a unique double-window concept which may have important applications in the laser-based ignition of tank rounds which utilize a stub case.

Lasers may be mounted on external hardware at the gun mount or may be directly attached to the gun breech. In either scenario, the laser must be sufficiently sturdy to survive the high-energy gun recoil forces. The optical components of the laser such as lenses, flashlamps, and rod can survive recoil forces if the laser is attached to the gun mount and isolated from moving parts of the gun. The laser radiation can be coupled to the breech through optical fibers which can dissipate recoil forces. Investigations to ascertain the survivability of a breech-mounted laser system are anticipated. The laser must also use fail-arm-safe electronics to both alleviate unwanted firings and serve as an integrity verification of the optical ignition train. In this configuration, optical shutters (beam blocks) prohibit unwanted firing unless the munition is loaded into the gun. Inert, low-energy laser diodes which are incapable of initiation themselves can readily be incorporated within the optical train and electronics of the primary ignition laser system to check for optical continuity.

There are many important characteristics of the laser which must be addressed. These laser parameters include energy, power density, pulse length, wavelength, and repetition rate. Lasers which have been

examined as ignition sources include rare-gas discharge lasers (excimers), CO₂ lasers, solid-state lasers such as Nd:YAG or Nd:glass, and small diode lasers. Excimer lasers are convenient sources of ultraviolet (UV) light which can be delivered at high repetition rates. Most energetic materials used in gun propulsion absorb well in the UV, however, the pulse length of these lasers (nanoseconds) is too short for reliable initiation. The high peak-powers that are generated tend to cause ablation (blow-off) rather than ignition of the energetic material. In addition, the UV wavelengths produced by these lasers is not readily transmitted through optical fiber material and/or can damage the input coupler ends of the fibers. CO₂ lasers can readily generate high-energy pulses which can easily ignite energetic materials, however, the laser wavelength it produces (10.6 μ) cannot be readily transmitted through conventional glass optical fibers. Germanium fibers have been developed which will readily transmit this wavelength, but they are very brittle, expensive, and cannot be manufactured in lengths suitable for gun applications. There are many other types of lasers which may serve as candidate igniters. A particularly attractive source is the solid-state laser based upon the Nd³⁺ ion. Generic lasers of this type are the Nd:YAG and Nd:glass which operate near 1.06 μ and 1.05 μ, respectively. These laser systems can be made very small (pyrotype), rugged, reliable, long-lived, and inexpensive. Laser radiation near 1 μ can readily be transmitted through very durable and inexpensive fused silica optical fibers over great distances with negligible loss. These lasers can operate in continuous mode or produce picosecond to millisecond pulses. This laser wavelength is also readily transmitted through sapphire breech window material. The Nd:glass laser has been extensively used as an ignition source within the LIGHT Program as a result of these attributes.

The aforementioned discussion summarizes key issues which have been considered in the ongoing development of a laser-based ignition system for large-caliber guns. The bulk of this report describes the preliminary experimental research and testing in the development of a laser-based ignition system for the Advanced Field Artillery System (AFAS) 155-mm howitzer with candidate propulsion concepts—Unicharge and Liquid Propellant (LP)—and the Advanced Tank Armament Cannon System (ATACS) 140-mm tank gun round. The goal of the Unicharge laser ignition program at present is to eliminate the current M82 primer from the gun breech and to ignite the blackpowder igniter pad with a laser with no modification to Unicharge. The long-term future goal is to eliminate all igniter material from the ignition train and directly ignite the propelling charge with a laser at multiple points to achieve isochronic ignition. The immediate goal of the ATACS laser ignition program is to replace the primer with an optical feed to couple laser energy into two blackpowder pads within the two-piece ammunition. The long-term future goal is to similarly eliminate all primer and igniter material from the round. The current Unicharge and ATACS propellant candidates are M30 and JA2, respectively; however, because

of future insensitive munition requirements for all large-caliber gun systems, LOVA-type propellants, which are inherently difficult to ignite, will be utilized.

2. EXPERIMENTAL

There are numerous experimental setups and configurations of apparatus that are currently being employed in this work. LIGHT is a broad-based, basic, developmental research program aimed at understanding the chemical and physical interactions of lasers with energetic materials such as propellants. Figure 1 depicts the interaction of laser light with the surface of a propellant sample. Important parameters include laser absorption at the surface of the grain, depth penetration, pyrolysis gas generation, thermal diffusivity, heat conduction, surface reflectivity, ignition, pressure generation, transient and sustained combustion, flamespread to adjacent grains, and extinction. These parameters are fully characterized in a diagnostic laboratory in order to optimize the conditions for successful ignition. The ignition technology developed in the laboratory may then be tested and evaluated in small-scale simulators in an indoor range. Important parameters such as ignition delay times, pressure-time curves, light emission measurements, and high-speed photography are measured. The laser-ignition train is then repeatedly tested in a full-scale ballistics simulator and these parameters are measured again. Successful testing in the simulator is a prerequisite for firing in the actual large-caliber gun.

Figure 2 depicts a schematic of a typical laboratory setup. There are numerous diagnostic lasers which are available to probe ignition and combustion events in the laboratory such as a Nd:YAG-Dye laser system which produces tunable laser light. Two high-energy Laser Photonics Nd:glass lasers serve as ignition sources. These lasers are variable energy (up to 30 J laser energy/pulse) and can generate pulse widths (using a pulse-forming network) from 100 μ s to 10 ms. Diagnostics equipment includes optical multichannel analyzers, spectrometers, pressure sensors, digital scopes, and other high-speed image processing equipment. The beam diameter is 6.35 mm and divergence is 3-4 mrad. The calculated diameter of the laser beam at the focus of this laser varied from 300 to 500 μ , depending on the focal length of the lens used in either a pyrolysis or laser ignition experiment. This laser beam was focused into a single 300-cm-length, 1-mm-diameter, cladded, solid-core, fused silica optical fiber or into an optical fiber bundle with a nine-way split which gave ~ 1-2 J laser energy at the end of each SMA connector. The pulse energy was measured with a Scientech volume-absorbing disc calorimeter Model No. 38-0103 and analog meter.

Solid Propellant Ignition and Combustion

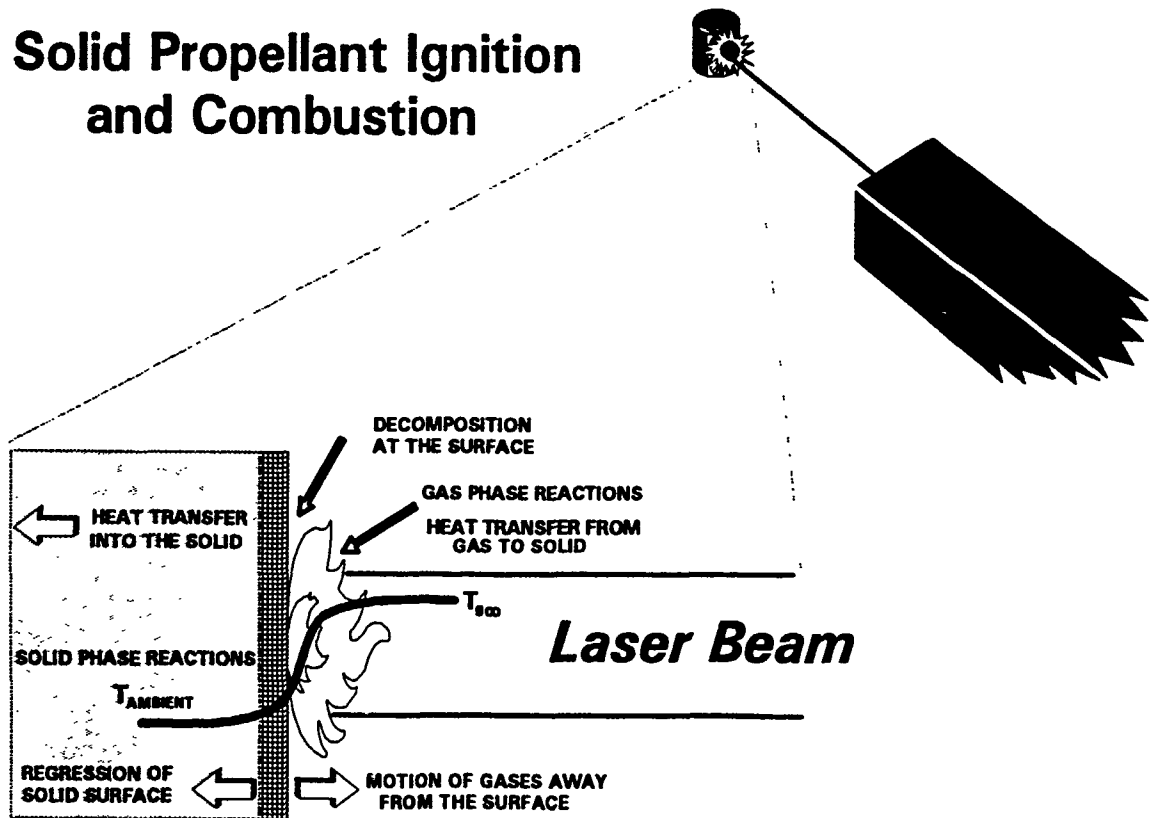

Figure 1. Laser Interaction With Propellant Surface.

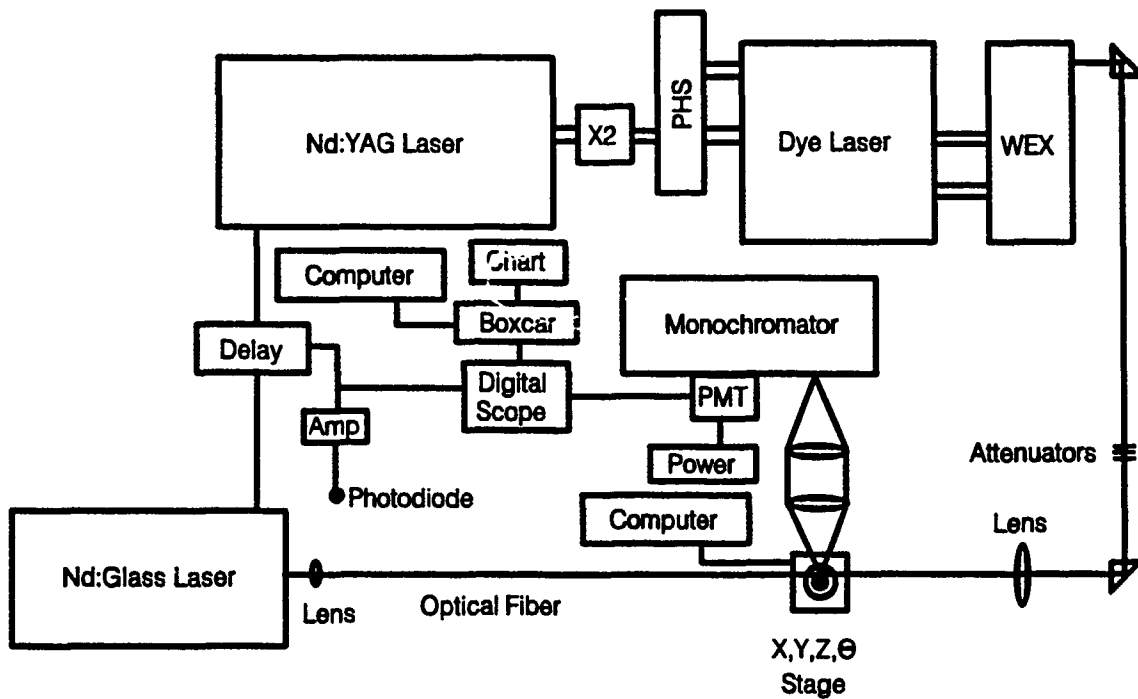

Figure 2. Pump-Probe Laser Experimental Setup.

The propellant grains were mounted on a high-precision motion stage (a stack of three Daedal series 100000 linear micropositioners and one Daedal series 20000—five in rotary table) with 4 degrees of control (X,Y,Z, H). The translational stages each provide 4 inches of travel with a translational accuracy (straight and positional) of $\pm 5.0 \times 10^{-5}$ in/in of travel and bidirectional repeatability of 5.0×10^{-5} in. The rotational stage provides angular repeatability of 0.2 arc/min with an accuracy of 3.0 arc/min. Each stage is driven by a stepper motor with microstepping controlled by an Epson Model Plus microcomputer. Time sequencing of the two lasers was accomplished using a high-precision (± 10 picoseconds) digital delay generator (Stanford Research Systems, Model No. DG 535) which was triggered with the amplified signal from a high-speed pin-photodiode. A remote control outlet at the long-pulse laser generates a TTL trigger pulse when the laser fires which can trigger another source or it accepts a similar TTL pulse for firing by an external trigger.

3. DISCUSSION

3.1 Blackpowder Ignition (Unicharge). Interior ballistic (IB) calculations suggest that isochronic ignition of multicomponent ammunition can lead to substantial benefits such as system safety and reliability. Representative results of IB calculations which model the simultaneous ignition of six Unicharge components in a 155-mm gun using a laser system are given in Figure 3. Localized ignition (nonisochronic), which leads to nonuniform flamespread within the propellant bed, may produce pressure differentials (axial pressure waves) which can lead to gun failure. Gun pressures calculated at the breech and forward chamber areas (curves b and c, respectively) as the result of the simultaneous ignition of all components show essentially no pressure differential (curve a). A laser-based ignition system for Unicharge also has the potential to solve stand-off problems in low zones. The conventional M82 primer cannot reliably ignite the component if it were to slide up the gun barrel at large stand-off distances. A laser-based igniter can easily achieve ignition regardless of the stand-off (Figure 4). A laser-based ignition system can also simplify the ignition train through the complete elimination of the primer which is inherently difficult to insert and/or extract using an autoloader system. Thus, a laser-based ignition system can potentially solve many gun-related problems either as a primary ignition system or as an alternate ignition system. It is desirable for either conventional or alternate ignition sources for large-caliber guns to be readily used or interchanged as required. A conceptual drawing of a Unicharge laser-based igniter train is shown in Figure 5. In this concept, no alteration whatsoever is required to existing Unicharges.

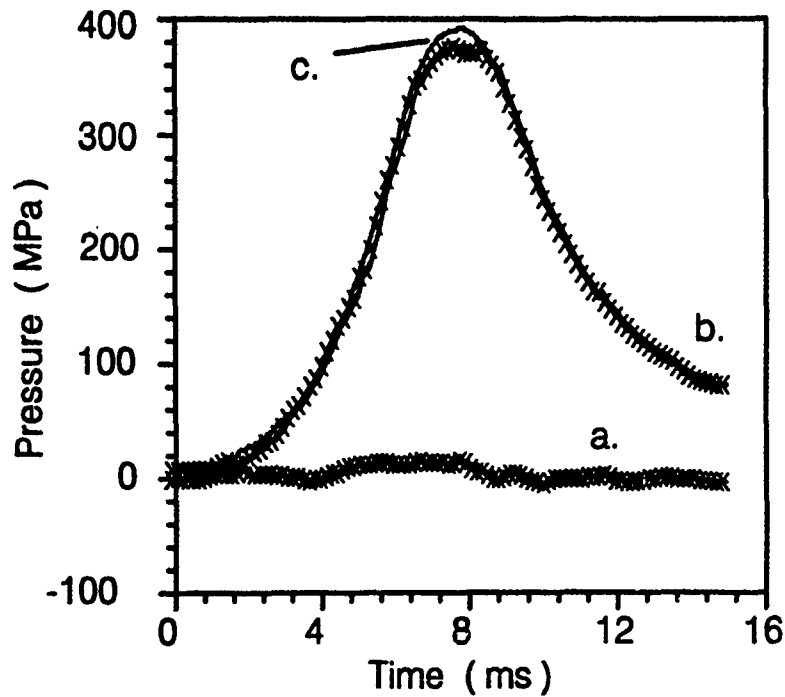
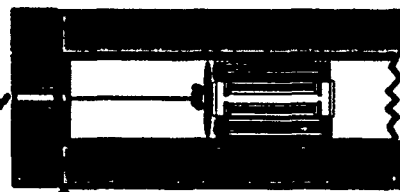

Figure 3. Unicharge Interior Ballistics Calculations. Simultaneous Laser Ignition of Six Unicharges Reduces Pressure Differentials in a 155-mm Gun Chamber.

Solution to Unicharge Stand off Problem

Sliding Breech Block



Window Roller Cleaner

Laser

Figure 4. Solution to Unicharge Stand-Off Problem.

Laser Ignition System Concept

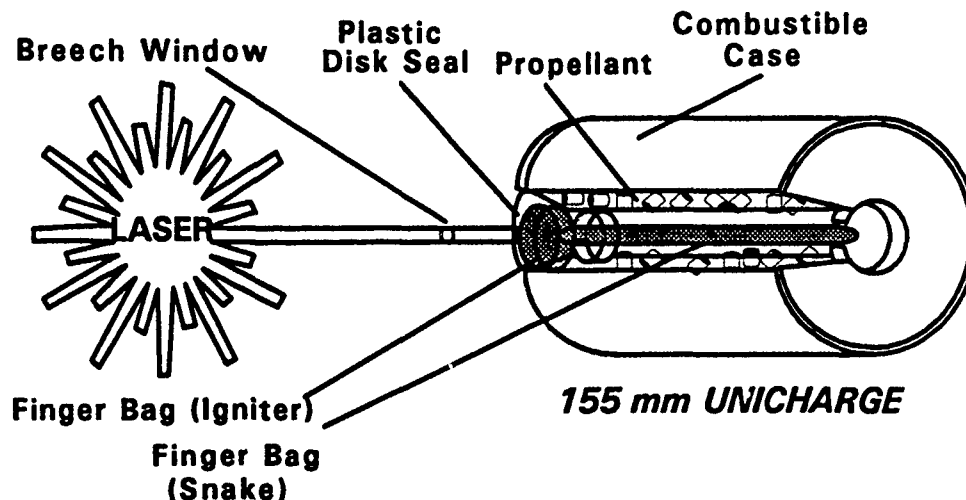

Figure 5. Schematic of Unicharge Laser Ignition Concept.

The laser beam must pass through several interfaces within the chain to be effective. These include: a sapphire window in the breech, a thin window covering on Unicharge (which is composed of mylar), and a mesh bag which contains blackpowder. The transmission of the laser beam through these media has been evaluated. The Nd:glass laser at 1.05μ transmits nearly 100% of the incident beam through the sapphire window. Small reflection losses of a few percent are encountered at the window surface. These losses can be minimized by using hard dielectric coatings on the sapphire substrate. The laser beam must also pass through the mylar window with low loss. Detailed experimentation has shown that, regardless of the laser pulse duration (2–10 ms), 70% of the laser was transmitted through with no damage to the mylar in 20 repeated shots (Figure 6); 30% of the laser beam was absorbed and/or scattered. It is interesting to note that the window was not burned or charred as a result of laser transmission. An investigation of the interaction of the laser beam with the blackpowder bag material gave no evidence whatsoever of ignition. The weaving (mesh) of the bag material was sufficiently loose to readily allow for laser transmission through the bag.

A detailed investigation of the laser parameters required to ignite small blackpowder igniters (blackpowder in bags) through sapphire and mylar windows was performed. A schematic of the test configuration is shown in Figure 7. An electronic pretrigger signal from the laser triggered the sweep of a high-speed digital oscilloscope. Two high-speed photodiodes observed the ignition event. The first photodiode was optically shielded and insulated to observe light emission other than that which resulted from the laser. The second photodiode captured light emission from the blackpowder ignition. The laser pulse was characterized by having a Gaussian-type spatial intensity distribution across beam. Mode

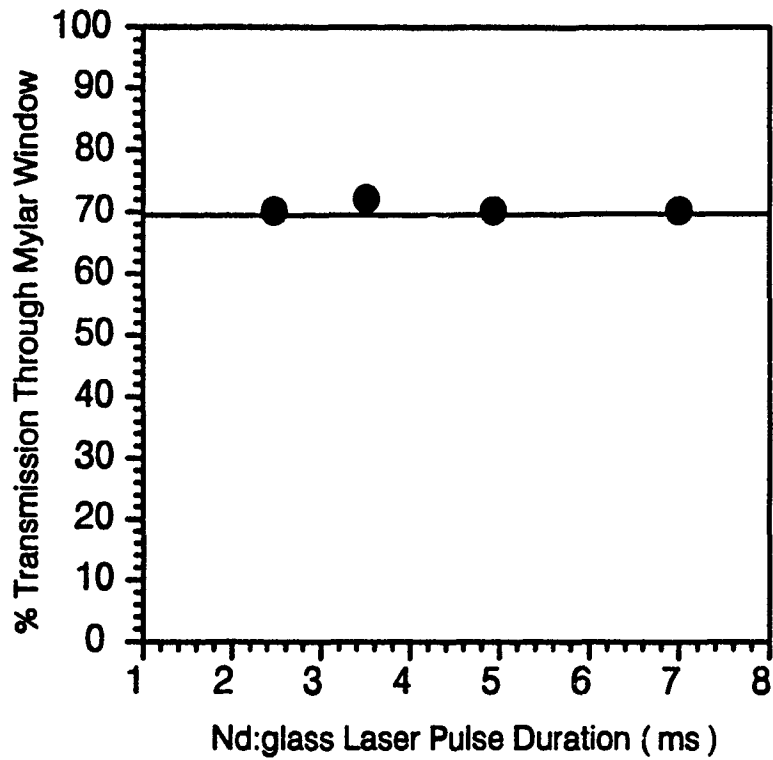

Figure 6. Transmission of Nd:Glass Laser Radiation Through a Mylar Window.

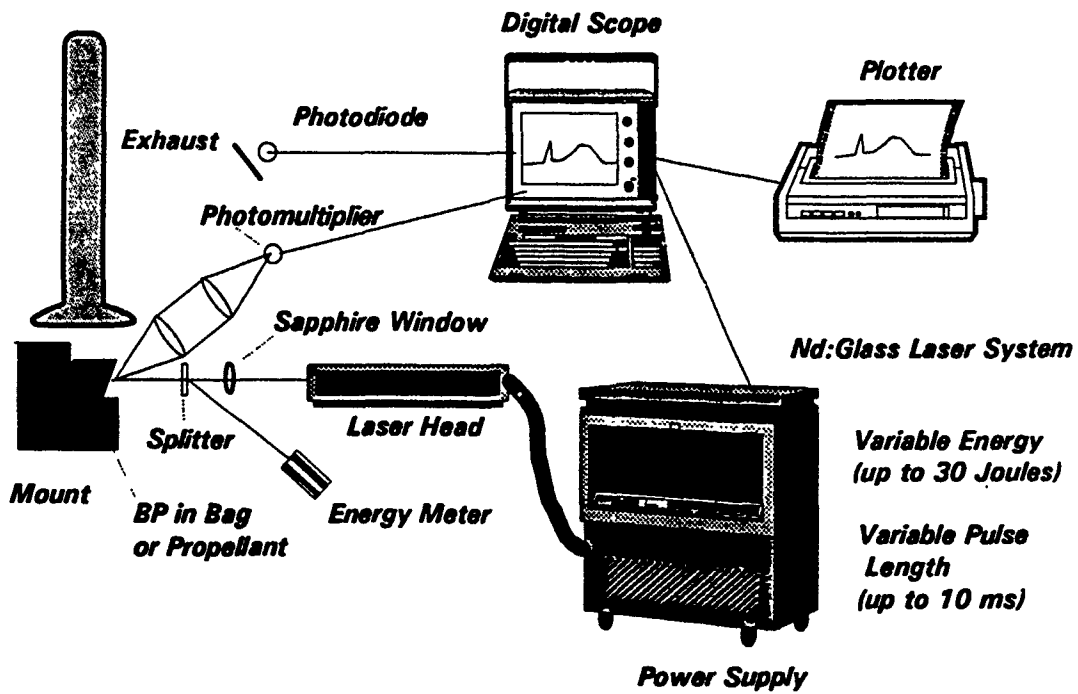

Figure 7. Laser Ignition Test Setup.

structure can indeed vary spatially from pulse-to-pulse as a result of thermally induced distortions (photon modes) within the rod as it is heated. A parametric investigation of the laser pulse duration, laser energy, and ignition delay on the ignition of blackpowder revealed several reproducible trends. Tests were all performed at atmospheric pressure on unconfined samples. The criterion for ignition was a single laser pulse which resulted in sustained ignition and complete combustion which consumed the entire sample (Ostrowski 1979). If the sample did not ignite, then it was discarded and replaced with an identical sample. A second laser shot into a previously irradiated sample showed that the first laser pyrolyzed the material which produced new chemical products with reactivities that differed from the original sample; this resulted in a lower ignition threshold. A similar behavior was also observed in solid propellant direct ignition and in the ignition of LPs. Figure 8 is a schematic which illustrates the trends that were observed in blackpowder ignition. At constant energy of 2 J/pulse, the ignition delay increased with increasing laser pulse widths, but the ignition energy threshold decreased with increasing laser pulse length (i.e., longer laser pulses required less energy for ignition than shorter laser pulses). Regardless of the laser pulse duration, for a given laser pulse, increasing the energy reduced the ignition delay. Although longer laser pulses had a lower energy threshold than shorter pulses, the increased ignition delay time is due to conductive losses early on in time. Figure 9 (a-d) shows plots of ignition delay versus laser pulse duration at constant energy of 2 J for 1-, 3.5-, 5- and 7-ms pulses. The first signal in each curve is laser scatter and the second curve is light emission from the burning blackpowder. In all ignition tests, the blackpowder burned (unconfined) within a 30-40 ms time period measured full width at half maximum (FWHM). These investigations were made using an unfocused laser beam.

It was found that if the laser beam were focused very tightly to a narrow beam waist, then energy input to the material cannot compete with thermal diffusion of the energy into the material such that ignition delay times became much longer or sustained combustion was not achieved. These conditions, however, required extreme focusing. A key feature of this work which is readily apparent is that, although at constant energy, longer pulses have a longer ignition delay, simply increasing the energy results in minimal ignition delays (Figure 10). The top plot in Figure 10 shows an example of two different laser pulses. The lower plots in Figure 10 show the effect of doubling the laser energy using two identical blackpowder igniters. Using 4-J input laser energy, the blackpowder begins to burn during the laser pulse; therefore, a plausible method of minimizing ignition delay times for blackpowder is to use as much unfocused laser energy as possible. Note that special care must be taken when examining the effect of laser pulse duration on delay time. The laser pulse shape from a 1-ms pulse is somewhat Gaussian in shape; however, the pulse-forming network in the laser produces square wave pulses that vary in intensity

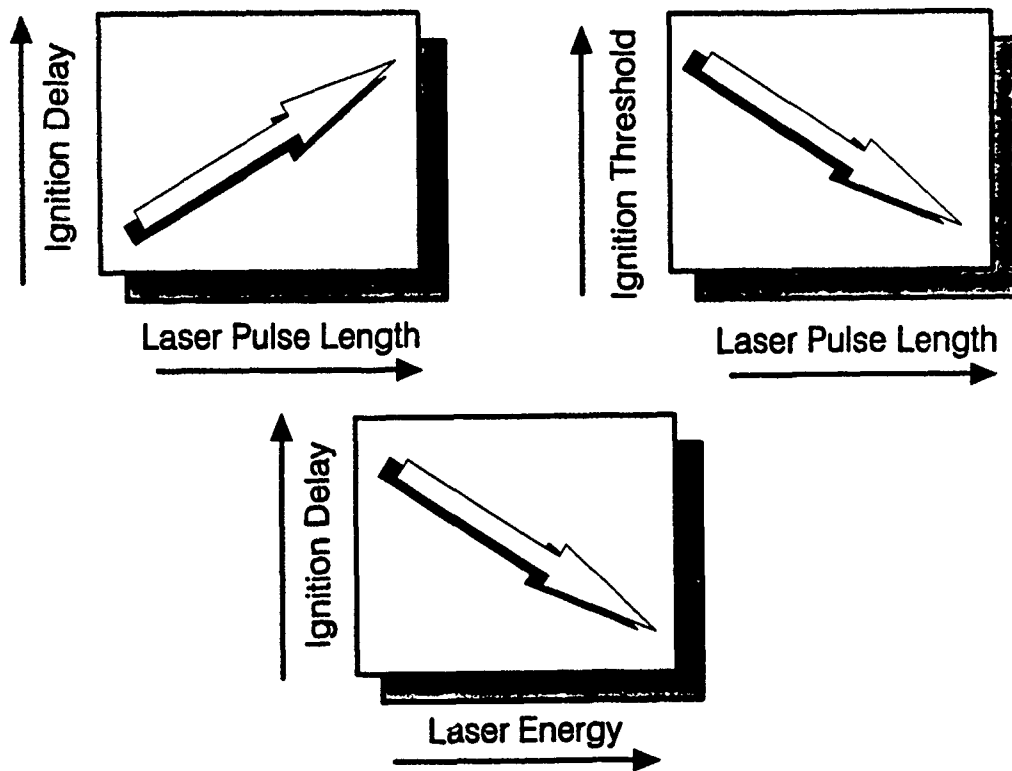

Figure 8. Trends Observed in Blackpowder Ignition.

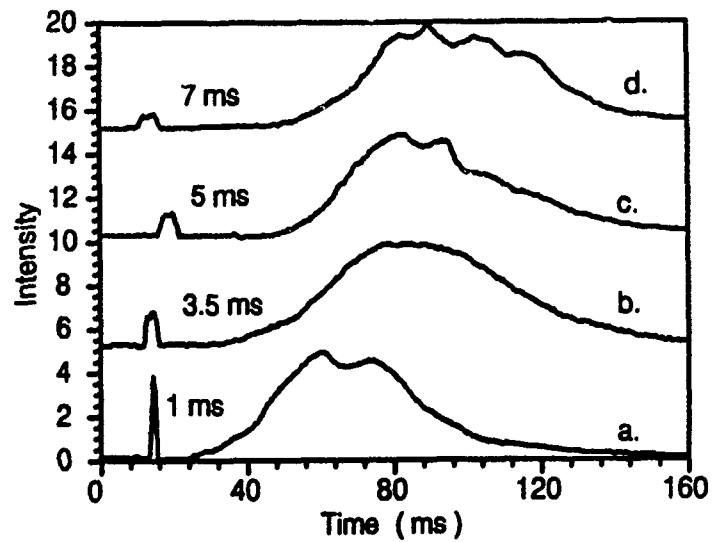

Figure 9. Effect of Laser Pulse Duration on Blackpowder Ignition Delay at Constant Laser Energy (2 J).

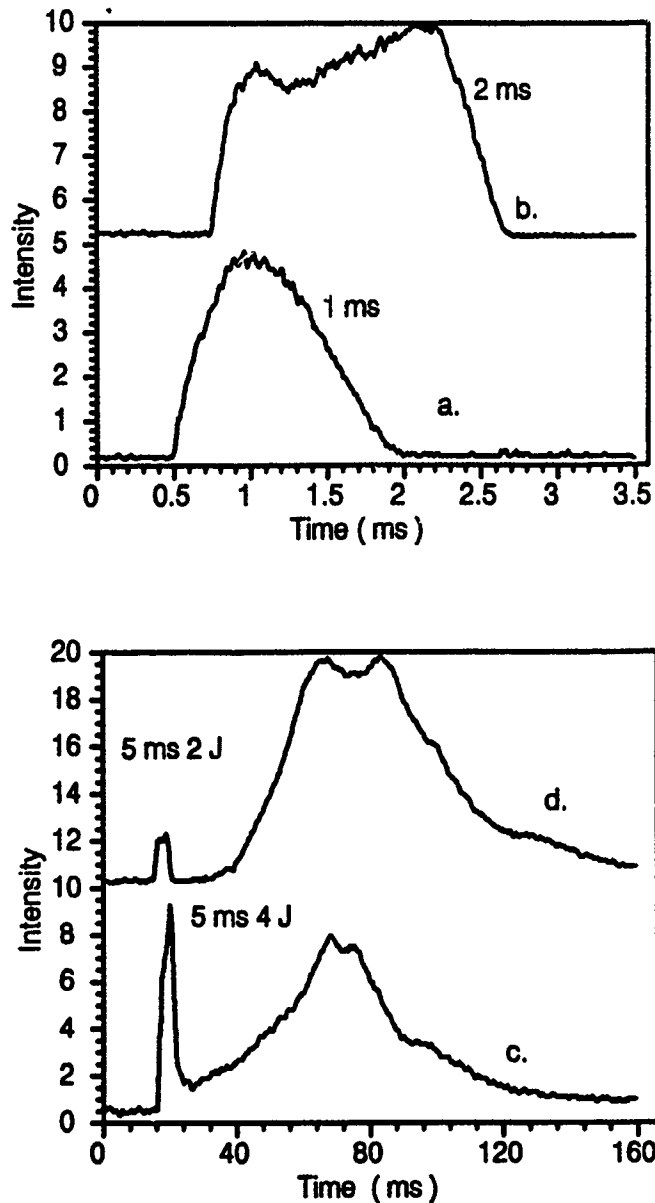

Figure 10. Temporal Profiles of Laser Pulses (Top Drawing) and Effect of Increased Laser Energy on Ignition Delay at Constant Laser Pulse Width (Lower Drawing).

by ~10%. Nonetheless, the trends we have observed in blackpowder ignition are reproducible. The research-type lasers, which were used in these experiments, were purchased in order to determine the optimal laser energy and pulse duration to employ in a fieldable system. These results suggest that laser pulse lengths 1 ms or greater which deliver several joules of energy will reliably ignite blackpowder charges with a safety factor about five.

Extensive laser ignition tests were also performed in an indoor range using large samples of blackpowder (28 g, 1 oz) similar to the blackpowder charge contained in a Unicharge increment. It was found that these charges could be readily ignited using the same parameters as the smaller samples. Tremendous volumes of gas and hot particles were generated in the ignition event and all of the igniter material was completely consumed. Next, a series of experiments using an optical fiber network for multipoint ignition of blackpowder were performed. The Laser Photonics system has provided for connection to a nine-way optical splitter which is interfaced to the laser through standard SMA-type connectors. The laser beam was focused into the bundle and about 2 J of laser energy were measured at the end of each 5-m optical cable. Figure 11 shows the laser ignition data for the initiation of six blackpowder igniters. Curve a in Figure 11 shows a timing trace of the 10-ms laser pulse used in this experiment. Curve b in Figure 11 shows a time-intensity trace which results from the ignition of six 1-oz blackpowder igniters which was detected by a single photodiode and demonstrates the near simultaneous ignition of all igniters. It is important to reiterate that the initial Unicharge ignition system which is being developed requires no alteration to the existing Unicharge. The ignition stimulus (laser light) strikes the first blackpowder pad in the first Unicharge loaded into the gun. Ignition of this first blackpowder igniter spreads to the remaining charges loaded in the gun. A conventional M82 primer generates a gas jet of hot gases and particles which assists propagation of the ignition stimulus into the full charge. Investigations in a full-scale ballistics simulator are in progress to compare the ignition stimulus provided by the M82 primer with that of the laser igniter.

Laboratory experiments are now underway to examine pressure-time traces from the ignition of blackpowder samples which are confined. Blackpowder charges are contained in a small windowed pressure vessel equipped with a sapphire window and a mylar blow-out disk for safety in the laboratory. An example of preliminary data recorded under these experimental configurations is shown in Figure 12. Within a few milliseconds after the laser has fired, there is a rapid increase in pressure from the gassification process occurring during the blackpowder combustion. The sudden drop in pressure signals the rupture of the mylar diaphragm. These experiments indicate that hot gases required for the ignition of the propellant bed are produced very quickly and can facilitate the spread of the ignition stimulus into the charge.

3.2 Blackpowder Ignition (ATACS). A laser-based ignition system is also being developed for the ATACS 140-mm tank gun. Similar to artillery guns, the incorporation of multicomponent ammunition in the propelling charge introduces interfaces which can interfere with reliable flamespreading

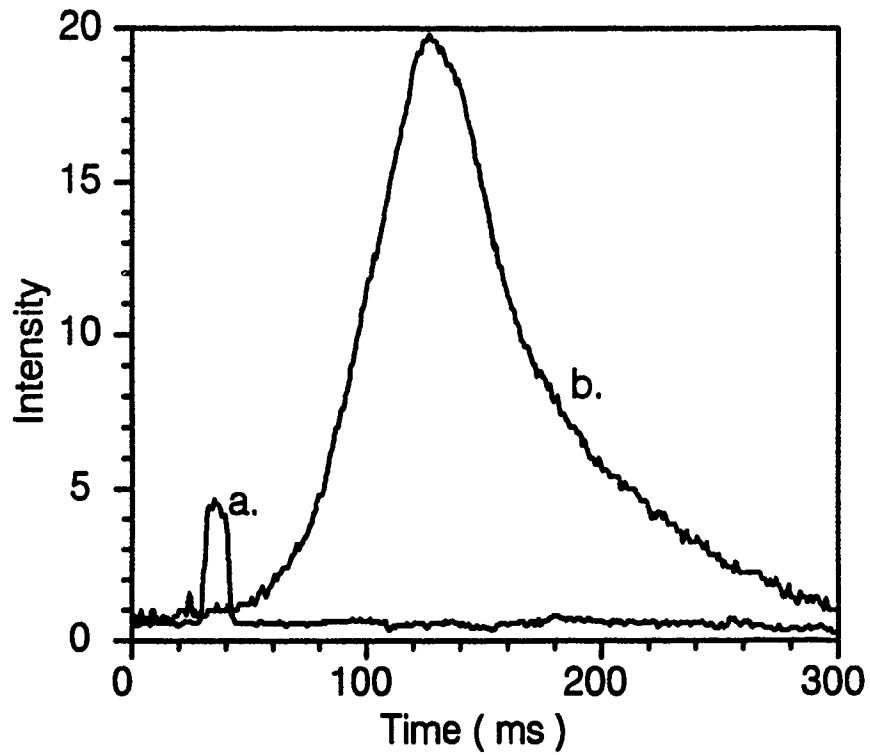

Figure 11. Light Emission from the Simultaneous Laser Ignition of Six Blackpowder Igniters.

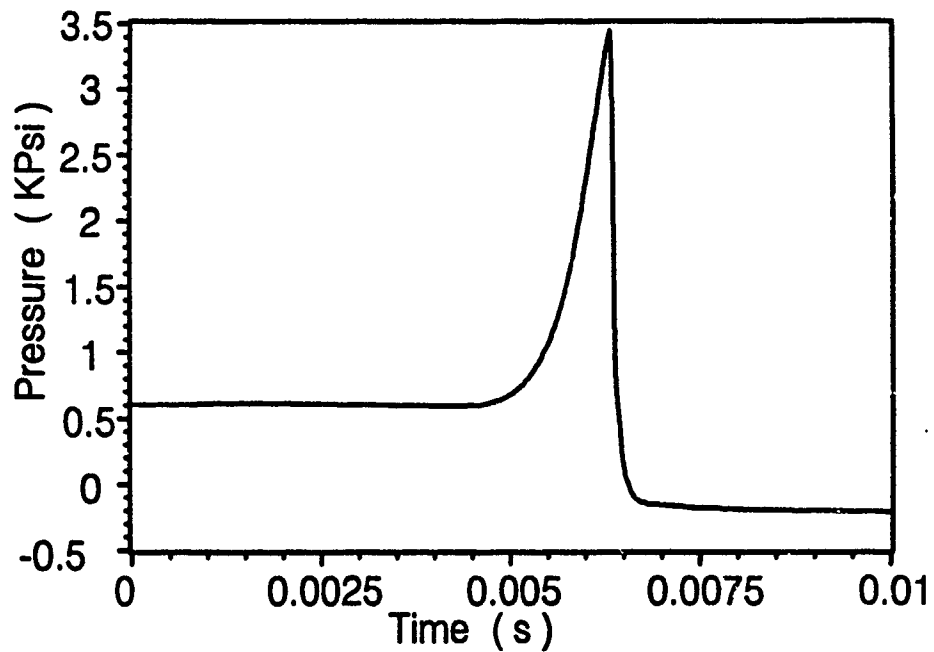

Figure 12. Pressure-Time Curve for Laser Ignition of Confined Blackpowder Samples.

characteristics in the combustion event. Interfaces which inhibit rapid flamespread within the propellant bed can lead to localized ignition which, in turn, may produce pressure differentials between the charge and projectile base. Pressure differentials can lead to oscillations which may result in catastrophic failure of the gun. IB calculations performed at BRL have shown that simultaneous ignition of multicomponent ammunition, such as the two-piece tank round, can minimize localized combustion, enhance flamespreading characteristics, and minimize the probability of gun failure. The rear component of the two-piece tank ammunition contains mainly propellant and igniter material. The forward component contains propellant and the projectile. Both components are assembled and loaded mechanically. The ignition requirements for tank munitions are much more stringent than those of artillery guns. Ignition of both components must be achieved on a millisecond timescale. The ATACS round, unlike an artillery charge, utilizes a stub case which makes an effective seal of the round to the breech. BRL has developed an ignition concept for ATACS which is presented in Figure 13. The gun breech contains a sapphire window through which the laser beam is transmitted; however, in addition, the stub case also contains a window. Combustion products may contaminate the stub case window, but the breech window remains protected from this environment. The next ATACS round which is loaded contains a fresh window. The laser can be mounted on the breech or coupled to the breech using optical fibers. An optical fiber which is contained within the first component of the two-piece ammunition delivers a portion of the laser energy to a blackpowder igniter in the rear of the forward ammunition component. The optical fiber in the rear component can easily be contained in an igniter tube or combustible case which will facilitate loading of the propellant. BRL also proposes the use of tapered optical fibers to facilitate the transfer of the laser beam from the breech into the optical fiber contained in the rear component (Figure 14). The tapered fibers easily align with the input laser beam from the breech and can be designed to partially transmit a portion of the laser beam to both igniters in the front and rear components. The laser beam which exits at the front end of the rear component can easily pass through the mylar interface and strike the rear igniter in the forward component to achieve simultaneous ignition. Optical fiber networks can also be distributed within the charge to achieve multipoint ignition or to accommodate complex projectile geometries which may extend into the rear portion of the ammunition (Figure 15).

Preliminary testing of a two-piece blackpowder igniter system is underway. Figure 16 gives time traces of a single laser pulse delivered to two ignition sites. Both pulses overlap exactly in time and, because the same laser pulse is delivered through a single fiber with a two-way split-off, the spatial mode structure of both pulses are essentially identical. Thus, variations in ignition delay can be minimized. Extensive experiments were performed utilizing this ignition concept for the simultaneous ignition of two

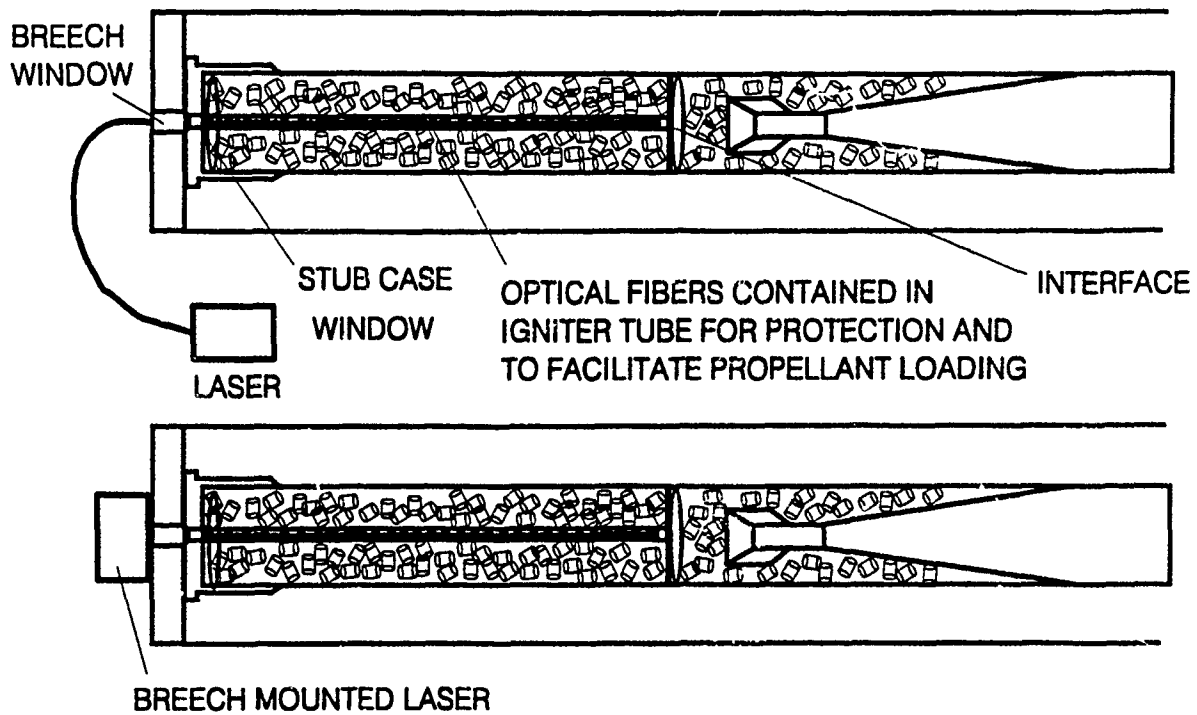

Figure 13. BRL ATACS Laser Ignition Concepts.

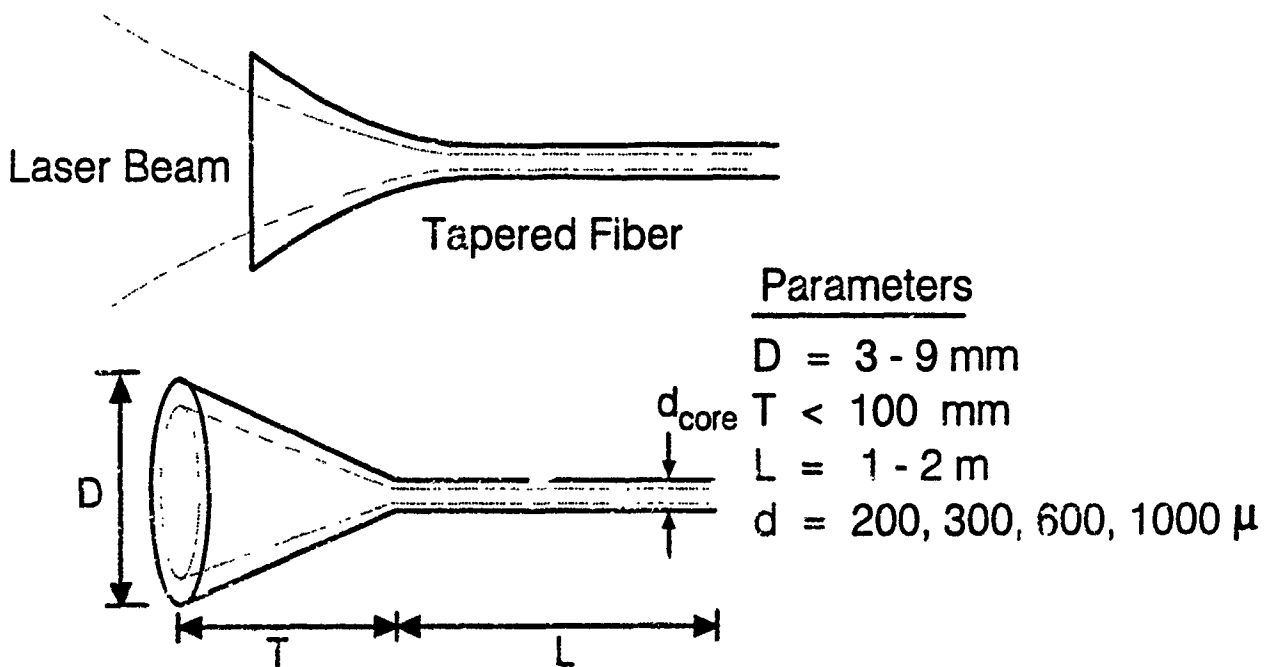

Figure 14. Characteristics of Tapered Optical Fibers.

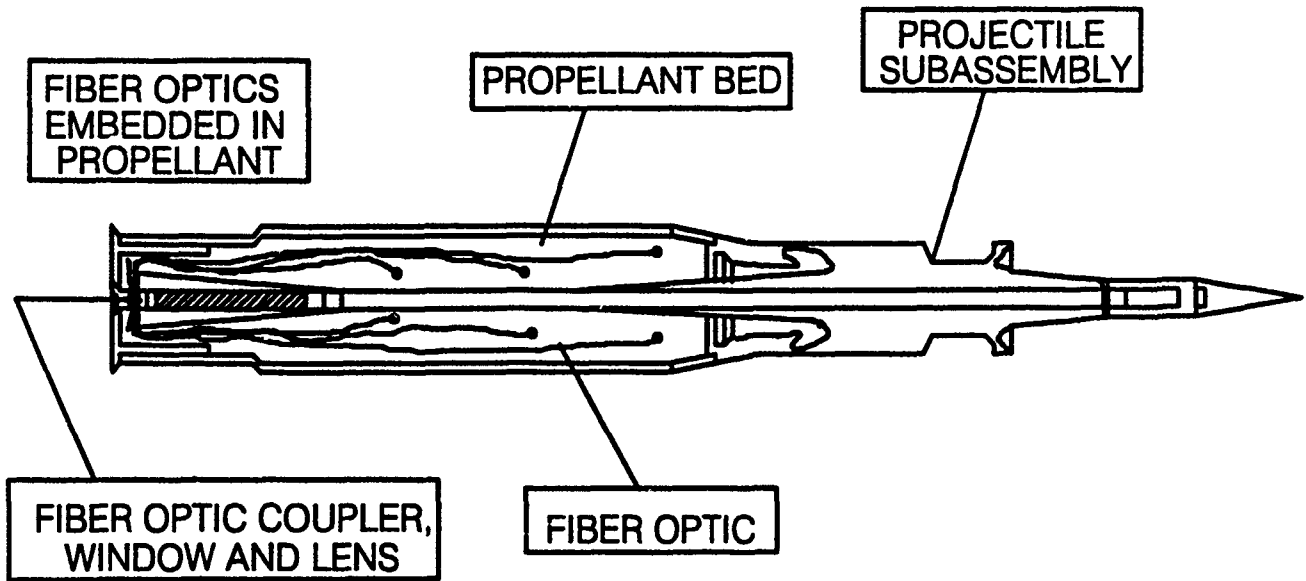

Figure 15. Tank Round With Embedded Optical Fiber Distribution System.

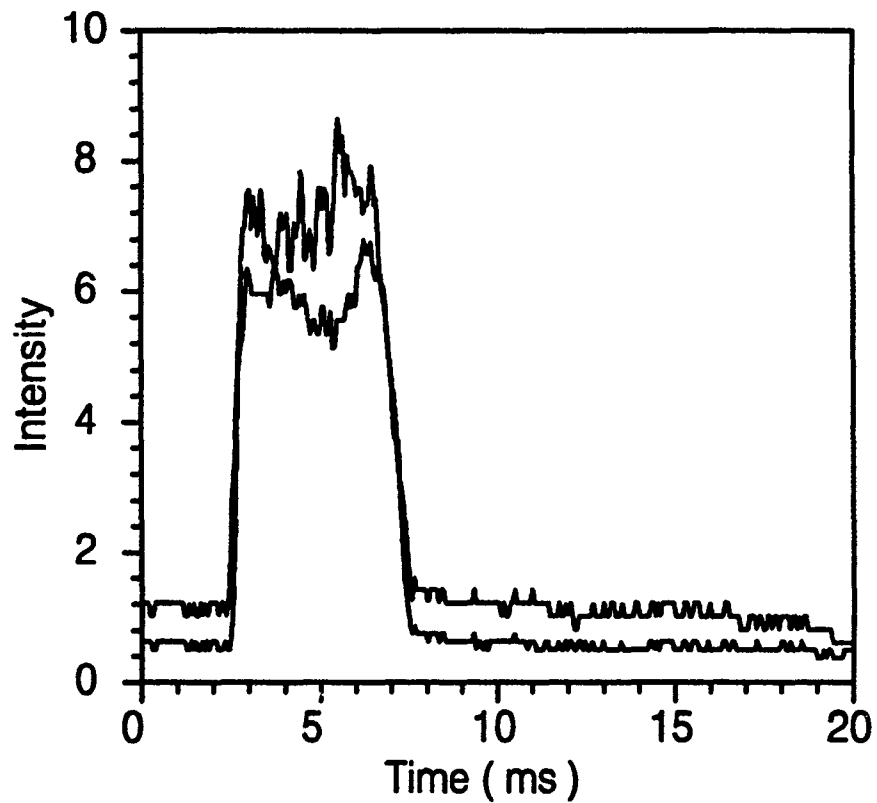

Figure 16. Simultaneous Delivery of Two Laser Pulses for ATACS Ignition.

blackpowder igniters for ATACS (Figure 17). Laser pulse energy was ~ 0.7–2.3 J/pulse depending on the laser pulse duration. Essentially simultaneous ignition of both igniters was achieved using this system. Next, the ignition of two large samples of blackpowder for ATACS was investigated using this ignition concept (Figure 18). A single photodiode captured the light emission from the initiation of both igniters. Successful ignition of both igniters resulted in complete consumption of the blackpowder.

3.3 Direct Propellant Ignition. The overall goal of the LIGHT Program, as previously mentioned, is to eliminate all primer and igniter material from the ignition train in large-caliber gun systems. Propellants can indeed be ignited using single laser pulses (Robitaille 1964; Ostrowski 1980); however, the heat transfer and subsequent flamespreading throughout the charge can be slow without the use of a distributed ignition system. For example, blackpowder and primer material are, relatively speaking, very energetic. They have fast burn rates, fast gas generation rates, and produce hot particles which serve to spread the ignition stimulus throughout the propellant bed. Direct laser-based ignition of a series of propellants using the Nd:glass laser was investigated. These include JA2, M30, LKL, LOVA (HELP1 (XM43), HELP2), and HMX1. An important consideration is the coupling of the laser energy into the propellant at the surface. Coatings on the propellant, such as graphite, greatly enhance the absorption of laser energy at 1.05 μ . Ignition is also enhanced when graphite is dispersed within the propellant formulation. An additional important consideration is the laser pulse duration. It was found that short laser pulses (nanosecond time scale) produce an intense light flash of ignited pyrolysis gases; however, sustained combustion of the bulk solid was not achieved after the laser pulse subsided. Apparently, the rate of energy input to the solid greatly exceeds the rate of thermal diffusion into the bulk sample such that "hot spots" are formed which results in surface ablation and ejection of material which inhibits sustained combustion. Longer laser pulses on the order of 3–10 ms, 5–10 J successfully ignited propellant samples in ambient air. Figure 19 gives two representative plots of the laser ignition of JA2 (ATACS) and M30—Unicharge propellants.

The laser pulse successfully ignited both samples and sustained combustion was achieved after the laser pulse subsided. JA2 propellant burns with a highly luminous flame and M30 propellant fizz burns at atmospheric pressure. During the initial stages of ignition in a gun system, the propellant is initially at ambient temperature and pressure, however, confinement allows for the subsequent pressure buildup which may serve to accelerate burn rate and flamespread throughout the bed. These types of experiments are therefore representative of the early stages of direct laser ignition of the propellant. Unconfined LOVA propellants were very difficult to ignite under ambient conditions. Confined LOVA samples (XM43)

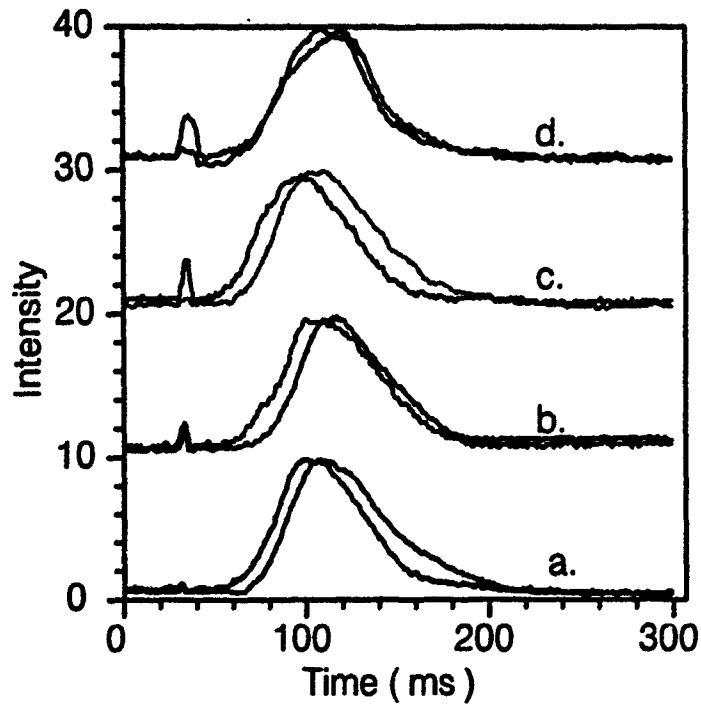

Figure 17. Simultaneous Laser Ignition of Two ATACS Blackpowder Igniters Using Various Laser Pulse Widths (Through Optical Fibers).

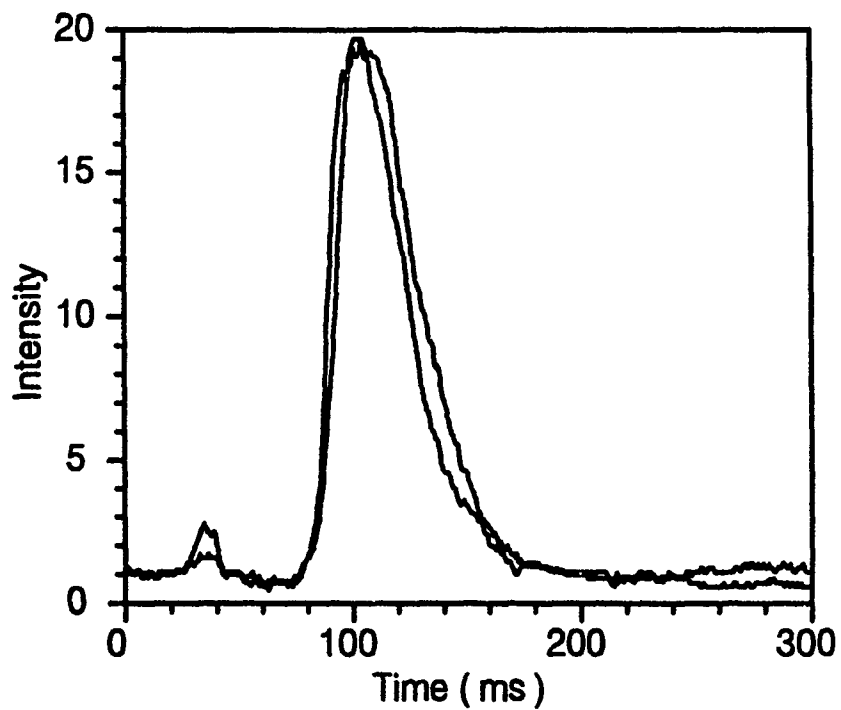

Figure 18. Simultaneous Laser Ignition of Two 1-oz ATACS Blackpowder Igniters.

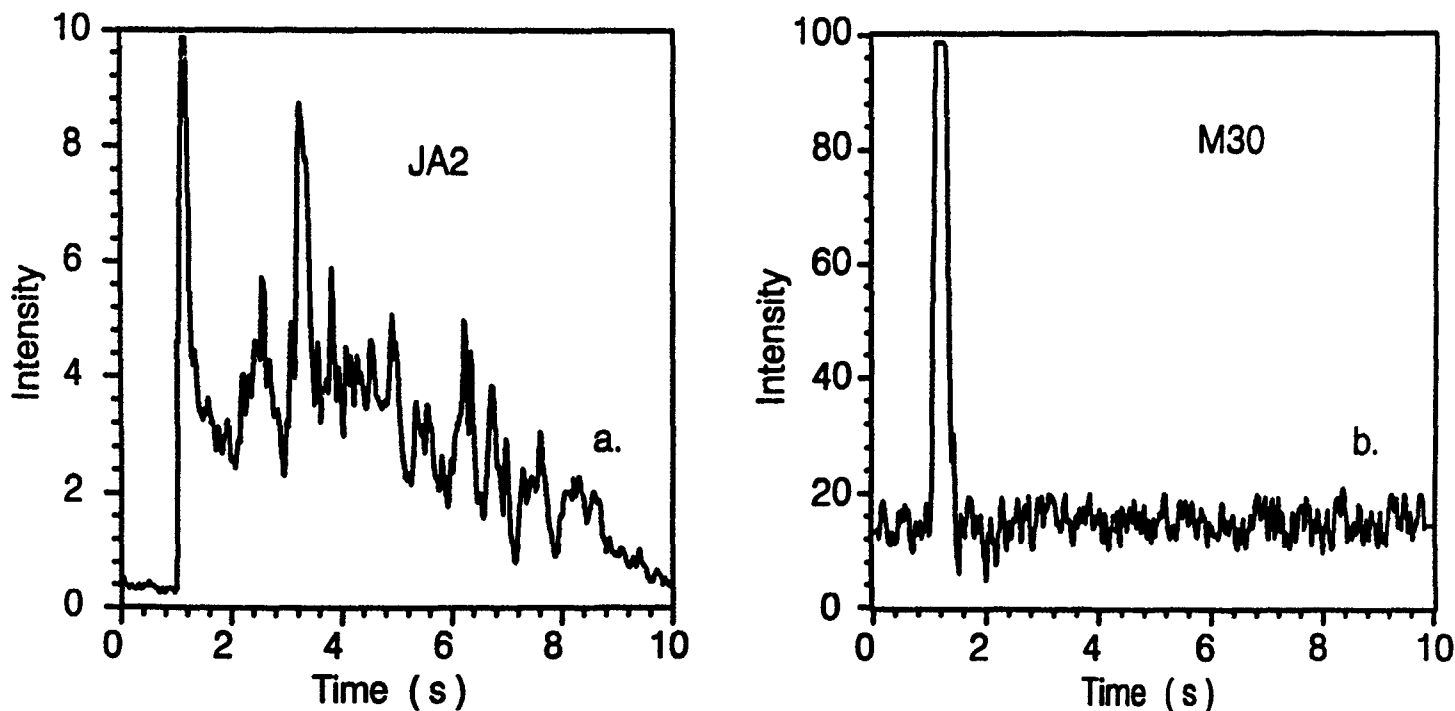

Figure 19. Light Emission From the Laser Ignition of JA2 and M30 Propellants.

were successfully ignited with a single laser pulse (10 ms, 8 J) (Figure 20). Rapid gas generation produced during the ignition and confinement (as illustrated in the pressure-time trace) led to sustained combustion until the mylar diaphragm burst. These experiments clearly demonstrate feasibility of direct propellant ignition in large-caliber guns. Experiments were also performed on early generation LOVA propellants. In particular, the formulations which used a HTPB binder could be ignited with as little laser energy as 0.5 J using a 2-ms laser pulse. Laser radiation at 1.05μ is readily absorbed deep within the propellant surface which facilitated the ignition. In general, all propellants which were graphite coated required less laser energy for ignition.

3.4 LP Ignition. LPs are also a candidate propulsion system for the AFAS 155-mm large-caliber gun. The current ignition system for the LP gun is a staged electrical igniter. A 30-mm electrical igniter is attached to the gun and contains three small volumes of LP. Discharge of 45 J of electrical energy across an electrode spark-gap ignites a small, 2-cm^3 , confined volume of LP. The flame propagates into a 20-cm^3 volume, then finally into a third 200 stage. The hot-burning LP is injected into a chamber fill volume of bulk LP (500 cm^3) wherein up to 17 L of LP is then injected (full charge for high zones). Apparently, there are problems associated with flamespreading within the staged ignition and survivability problems with the electrodes for repeated firings. BRL is presently investigating the development of a laser-based

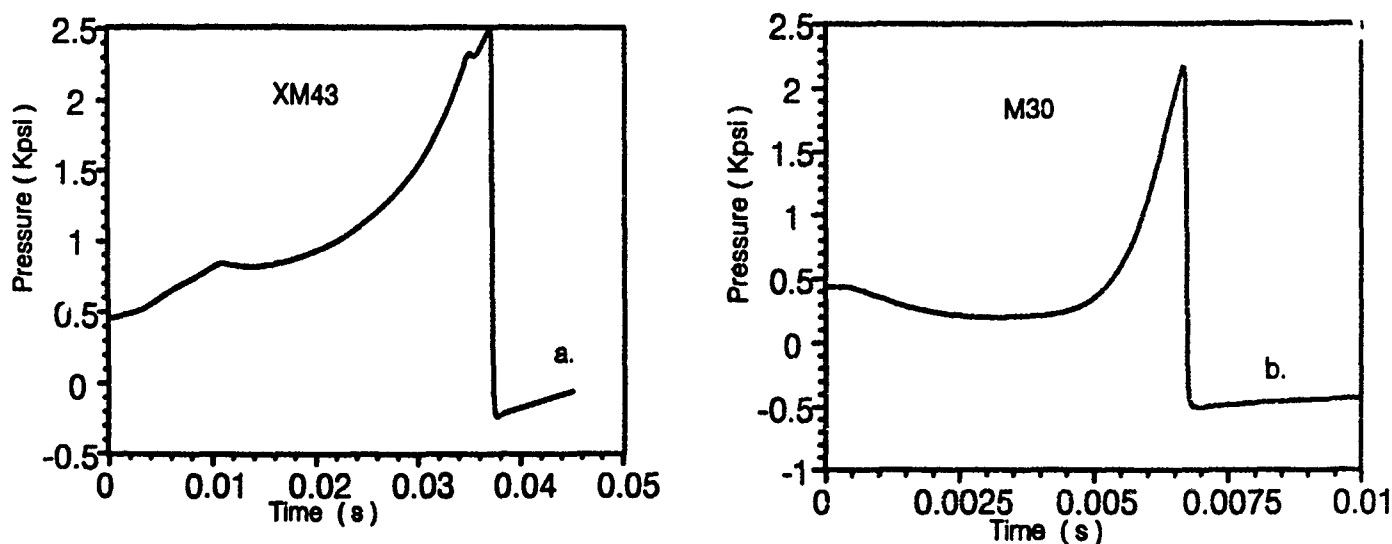

Figure 20. Pressure-Time Curves for the Direct Laser Ignition of Confined M30 and XM43 Propellants.

ignition system for the LP gun. A conceptual schematic is depicted in Figure 21. A laser-based ignition system may allow for one or more stages in the current igniter to be eliminated. In addition, a laser-based ignition system could replace existing electrodes in the current igniter which are not long-lived. Conversely, a laser-based igniter could be used in conjunction with an electric igniter to facilitate flamespread throughout the staged ignition system. A conceptual illustration of this concept is shown in Figure 22. Laser energy could be coupled into multiple points within the igniter using an optical fiber network. Sapphire windows and ignition points can be located at various points as required. The sapphire windows can be formed as a lens as required to increase the energy density at the ignition points. Contamination of the windows may not present the same problem as encountered in solid propellant gun environments.

A series of experiments on LP ignition using pulsed laser systems have been performed. We found, using a focused-pulsed Nd:glass laser, that suspended droplets of LP can be ignited into transient combustion; however, sustained combustion is difficult to achieve without confinement. The absorption cross section of LP increases in the UV and decreases in the near infrared where the Nd:glass laser

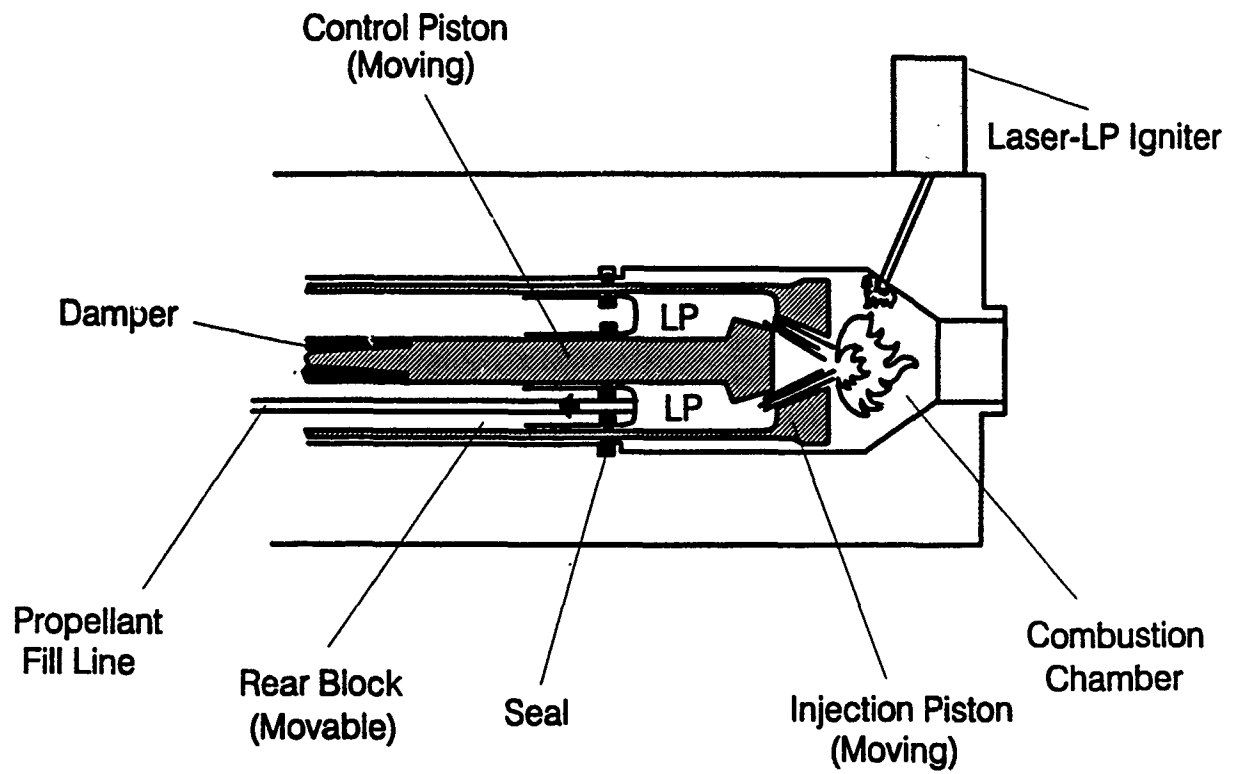

Figure 21. BRL Conceptual Depiction of LP Gun With a Laser-Based Igniter.

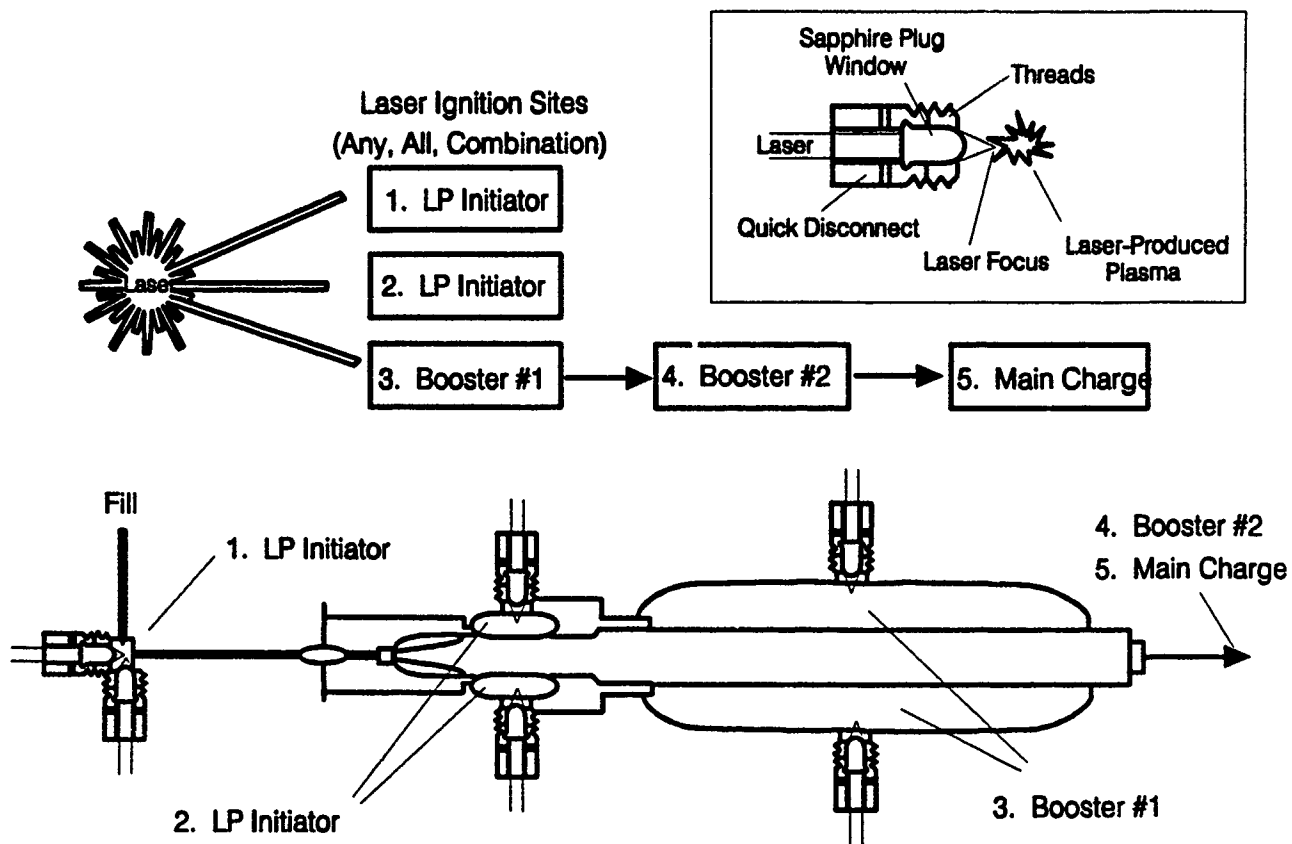

Figure 22. Schematic of BRL Laser-Based LP Igniter.

operates. Focused nanosecond UV pulses at 193 nm ignite the droplets, but combustion was not sustained under ambient conditions. Suspended droplets of LP were easily ignited at 1.05 μ , although sustained combustion was not possible without confinement and pressure buildup. Additives, such as graphite suspensions and IR dyes were doped into LP samples; however, confinement was required for sustained ignition. It is interesting to note that LP samples that did not ignite with a first laser pulse could be ignited or reignited with much less laser energy. This phenomenon has been attributed to laser decomposition of the LP (pyrolysis) to produce chemically different and more reactive products. These products have not yet been identified. A first laser pulse initiates the LP into transient combustion which subsides. A second laser pulse reignites the droplet with less laser energy and, in addition, combustion is sustained for a longer time duration. Laser ignition experiments on confined LP samples are currently in progress.

3.5 Double-Laser Pulse Ignition. Experiments aimed at utilizing multiple pulses with a single laser system and double pulses utilizing double-laser systems are being investigated for ignition of solid propellants and LPs. This concept involves the pyrolysis (Beyer 1978) of the sample to produce intermediates, which can then be ignited by a second laser pulse from a different wavelength laser. Initial experiments on the pyrolysis of JA2, for example, have identified both the presence of atomic oxygen and hydrogen. A probe laser system, which is tuned to resonant multiphoton excitation transitions of these atoms, shows the formation of laser-produced microplasmas, similar to those observed in reactive gases. The techniques required to generate the probe laser wavelengths is described elsewhere. When the probe beam is tuned to the multiphoton absorption transitions of these radicals, free electrons are produced from multiphoton ionization. Interaction of the intense laser field with the electron field results in a nonlinear amplification process which generates microplasmas. These microplasmas have sufficient intensity to ignite the pyrolysis gases, but have insufficient thermal feedback to the bulk material to achieve ignition of the solid. Pyrolysis gas diffusion away from the propellant surface may be sufficient to inhibit the ignition. Furthermore, the second probe laser energy is only ~ 1 mJ. This energy range has been shown to be sufficient to ignite reactive gases, but is not sufficient to cause ignition of the bulk solid. Similar types of experiments utilizing an excimer laser which can deliver more than a factor of 100 times more laser energy will be investigated.

4. CONCLUSION

The development of laser-based ignition systems for large-caliber guns has the potential to solve problems associated with reliable and reproducible flamespreading characteristics within propellant beds. The recent advances in gun propulsion systems which utilize multicomponent ammunition, autoloading devices for projectiles, and charges and primers, place new constraints on the ignition train. In addition, insensitive munition requirements for future gun systems may require alternate or nonconventional ignition sources to be implemented. As a result, laser-based ignition systems may prove to be the only viable initiation source for these munitions. Laser energy distributed through optical fibers embedded in a propellant bed cannot only insure simultaneous ignition of the charge, but also reduce overall system vulnerability from the elimination of all primer and igniter material from the munition. Recent advances in electronics and engineering technology have produced small, high-energy laser systems which are suitable as igniters. Extremely small, high-power laser diodes are being developed which can easily initiate high explosives and similar energetic materials. These types of devices may prove to be the lasers of choice in future gun systems as new technology developments increase energy output suitable for large-caliber gun initiation. Laser ignition systems may also have an impact on gun performance through temperature compensating and/or programmed delivery of laser energy through optical fibers. New developments in optical fiber material may produce energetic and consumable fibers which leave no residue in gun systems and, in addition, enhance ignition. BRL anticipates the development of a laser ignition model of a predictive to further understand the chemistry and physics of laser ignition and design igniters with specified characteristics.

INTENTIONALLY LEFT BLANK.

5. REFERENCES

- BenReuven, M., and L. H. Caveny. "HMX Deflagration and Flame Characterization." Princeton Kinetic Model for Pure Nitramine, AFRPL-TR-79-94, vol. II, phase 1, 1980.
- Beyer, R. A. "Molecular Beam Sampling Mass Spectrometry of High Heating Rate Pyrolysis—Description of Data Acquisition System and Pyrolysis of HMX in a Polyurethane Binder." BRL-MR-2816, U.S. Army Ballistic Research Laboratory, Aberdeen Proving Ground, MD, 1978.
- Deluca, L. "Radiative Ignition of Double-Base Propellants-II. Pre-Ignition Events and Source Effects." Technical Report ARO-9586.9-E, Army Research Office, 1975.
- Forch, B. E., and A. W. Miziolek. "Oxygen-Atom of Premixed Two-Photon Resonance Effects in Multiphoton Photochemical Ignition of Premixed H_2/O_2 Flows." Opt. Lett., vol. 11, p. 129, 1986.
- Forch, B. E., and A. W. Miziolek. "Ultraviolet Laser Ignition of Premixed Gases by Efficient and Resonant Multiphoton Photochemical Formation of Microplasmas." Combustion Science and Technology, vol. 52, p. 151, 1987.
- Forch, B. E., and A. W. Miziolek. "Laser-Based Ignition of H_2/O_2 and D_2/O_2 Premixed Gases Through Resonant Multiphoton Excitation of H and D Atoms Near 243 nm." Combustion and Flame, vol. 85, p. 254, 1991.
- Forch, B. E., J. B. Morris, and A. W. Miziolek. "Laser Techniques in Luminescence Spectroscopy." Invited book chapter, STP 1066, ed. T. Vo-Dinh and E. Eastwood, 1990.
- Ostrowski, P. P. "Laser Ignition of Solid Propellant Formulations." GC-TR-79-1036, 1979.
- Ostrowski, P. P. "Laser Ignition of Double- and Triple-Based Propellants." Technical Report, CPIA Pub. 329, vol. 2, 1980.
- Robitaille, L. L. "Laser-Induced Initiation of Military-Type Solid Propellants." BRL-MR-1549, U.S. Army Ballistic Research Laboratory, Aberdeen Proving Ground, MD, 1964.

INTENTIONALLY LEFT BLANK.

No. of Copies	<u>Organization</u>	No. of Copies	<u>Organization</u>
2	Administrator Defense Technical Info Center ATTN: DTIC-DDA Cameron Station Alexandria, VA 22304-6145	1	Commander U.S. Army Missile Command ATTN: AMSMI-RD-CS-R (DOC) Redstone Arsenal, AL 35898-5010
1	Commander U.S. Army Materiel Command ATTN: AMCAM 5001 Eisenhower Ave. Alexandria, VA 22333-0001	1	Commander U.S. Army Tank-Automotive Command ATTN: ASQNC-TAC-DIT (Technical Information Center) Warren, MI 48397-5000
1	Director U.S. Army Research Laboratory ATTN: AMSRL-D 2800 Powder Mill Rd. Adelphi, MD 20783-1145	1	Director U.S. Army TRADOC Analysis Command ATTN: ATRC-WSR White Sands Missile Range, NM 88002-5502
1	Director U.S. Army Research Laboratory ATTN: AMSRL-OP-CI-AD, Tech Publishing 2800 Powder Mill Rd. Adelphi, MD 20783-1145	1	Commandant U.S. Army Field Artillery School ATTN: ATSF-CSI Ft. Sill, OK 73503-5000
2	Commander U.S. Army Armament Research, Development, and Engineering Center ATTN: SMCAR-IMI-I Picatinny Arsenal, NJ 07806-5000	(Class. only) 1	Commandant U.S. Army Infantry School ATTN: ATSH-CD (Security Mgr.) Fort Benning, GA 31905-5660
2	Commander U.S. Army Armament Research, Development, and Engineering Center ATTN: SMCAR-TDC Picatinny Arsenal, NJ 07806-5000	(Unclass. only) 1	Commandant U.S. Army Infantry School ATTN: ATSH-CD-CSO-OR Fort Benning, GA 31905-5660
1	Director Benet Weapons Laboratory U.S. Army Armament Research, Development, and Engineering Center ATTN: SMCAR-CCB-TL Watervliet, NY 12189-4050	1	WL/MNOI Eglin AFB, FL 32542-5000 <u>Aberdeen Proving Ground</u>
(Unclass. only) 1	Commander U.S. Army Rock Island Arsenal ATTN: SMCRI-IMC-RT/Technical Library Rock Island, IL 61299-5000	2	Dir, USAMSA ATTN: AMXSY-D AMXSY-MP, H. Cohen
1	Director U.S. Army Aviation Research and Technology Activity ATTN: SAVRT-R (Library) M/S 219-3 Ames Research Center Moffett Field, CA 94035-1000	1	Cdr, USATECOM ATTN: AMSTE-TC
		1	Dir, ERDEC ATTN: SCBRD-RT
		1	Cdr, CBDA ATTN: AMSCB-CI
		1	Dir, USARL ATTN: AMSRL-SL-I
		10	Dir, USARL ATTN: AMSRL-OP-CI-B (Tech Lib)

<u>No. of Copies</u>	<u>Organization</u>	<u>No. of Copies</u>	<u>Organization</u>
1	HQDA (SARD-TC, C.H. Church) WASH DC 20310-0103	5	Commander Naval Research Laboratory ATTN: M.C. Lin J. McDonald E. Oran J. Shnur R.J. Doyle, Code 6110 Washington, DC 20375
4	Commander US Army Research Office ATTN: R. Ghirardelli D. Mann R. Singleton R. Shaw P.O. Box 12211 Research Triangle Park, NC 27709-2211	1	Commanding Officer Naval Underwater Systems Center Weapons Dept. ATTN: R.S. Lazar/Code 36301 Newport, RI 02840
2	Commander US Army Armament Research, Development, and Engineering Center ATTN: SMCAR-AEE-B, D.S. Downs SMCAR-AEE, J.A. Lannon Picatinny Arsenal, NJ 07806-5000	2	Commander Naval Weapons Center ATTN: T. Boggs, Code 388 T. Parr, Code 3895 China Lake, CA 93555-6001
1	Commander US Army Armament Research, Development, and Engineering Center ATTN: SMCAR-AEE-BR, L. Harris Picatinny Arsenal, NJ 07806-5000	1	Superintendent Naval Postgraduate School Dept. of Aeronautics ATTN: D.W. Netzer Monterey, CA 93940
2	Commander US Army Missile Command ATTN: AMSMI-RD-PR-E, A.R. Maykut AMSMI-RD-PR-P, R. Betts Redstone Arsenal, AL 35898-5249	3	AL/LSCF ATTN: R. Corley R. Geisler J. Levine Edwards AFB, CA 93523-5000
1	Office of Naval Research Department of the Navy ATTN: R.S. Miller, Code 432 800 N. Quincy Street Arlington, VA 22217	1	AFOSR ATTN: J.M. Tishkoff Bolling Air Force Base Washington. DC 20332
1	Commander Naval Air Systems Command ATTN: J. Ramnarace, AIR-54111C Washington, DC 20360	1	OSD/SDIO/IST ATTN: L. Caveny Pentagon Washington, DC 20301-7100
1	Commander Naval Surface Warfare Center ATTN: J.L. East, Jr., G-23 Dahlgren, VA 22448-5000	1	Commandant USAFAS ATTN: ATSF-TSM-CN Fort Sill, OK 73503-5600
2	Commander Naval Surface Warfare Center ATTN: R. Bernecker, R-13 G.B. Wilmot, R-16 Silver Spring, MD 20903-5000	1	F.J. Seiler ATTN: S.A. Shackleford USAF Academy, CO 80840-6528

<u>No. of Copies</u>	<u>Organization</u>	<u>No. of Copies</u>	<u>Organization</u>
1	University of Dayton Research Institute ATTN: D. Campbell AL/PAP Edwards AFB, CA 93523	1	Exxon Research & Eng. Co. ATTN: A. Dean Route 22E Annandale, NJ 08801
1	NASA Langley Research Center Langley Station ATTN: G.B. Northam/MS 168 Hampton, VA 23365	1	General Applied Science Laboratories, Inc. 77 Raynor Avenue Ronkonkama, NY 11779-6649
4	National Bureau of Standards ATTN: J. Hastie M. Jacox T. Kashiwagi H. Semerjian US Department of Commerce Washington, DC 20234	1	General Electric Ordnance Systems ATTN: J. Mandzy 100 Plastics Avenue Pittsfield, MA 01203
1	Applied Combustion Technology, Inc. ATTN: A.M. Varney P.O. Box 607885 Orlando, FL 32860	1	General Motors Rsch Labs Physical Chemistry Department ATTN: T. Sloane Warren, MI 48090-9055
2	Applied Mechanics Reviews The American Society of Mechanical Engineers ATTN: R.E. White A.B. Wenzel 345 E. 47th Street New York, NY 10017	2	Hercules, Inc. Allegheny Ballistics Lab. ATTN: W.B. Walkup E.A. Yount P.O. Box 210 Rocket Center, WV 26726
1	Atlantic Research Corp. ATTN: R.H.W. Waesche 7511 Wellington Road Gainesville, VA 22065	1	Alliant Techsystems, Inc. Marine Systems Group ATTN: D.E. Broden/MS MN50-2000 600 2nd Street NE Hopkins, MN 55343
1	AVCO Everett Research Laboratory Division ATTN: D. Stickler 2385 Revere Beach Parkway Everett, MA 02149	1	Alliant Techsystems, Inc. ATTN: R.E. Tompkins 7225 Northland Drive Brooklyn Park, MN 55428
1	Battelle ATTN: TACTEC Library, J. Huggins 505 King Avenue Columbus, OH 43201-2693	1	IBM Corporation ATTN: A.C. Tam Research Division 5600 Cottle Road San Jose, CA 95193
1	Cohen Professional Services ATTN: N.S. Cohen 141 Channing Street Redlands, CA 92373	1	IIT Research Institute ATTN: R.F. Remaly 10 West 35th Street Chicago, IL 60616

<u>No. of Copies</u>	<u>Organization</u>	<u>No. of Copies</u>	<u>Organization</u>
2	Director Lawrence Livermore National Laboratory ATTN: C. Westbrook M. Costantino P.O. Box 808 Livermore, CA 94550	1	Rockwell International Corp. Rocketdyne Division ATTN: J.E. Flanagan/HB02 6633 Canoga Avenue Canoga Park, CA 91304
1	Lockheed Missiles & Space Co. ATTN: George Lo 3251 Hanover Street Dept. 52-35/B204/2 Palo Alto, CA 94304	4	Director Sandia National Laboratories Division 8354 ATTN: R. Cattolica S. Johnston P. Mattern D. Stephenson Livermore, CA 94550
1	Director Los Alamos National Lab ATTN: B. Nichols, T7, MS-B284 P.O. Box 1663 Los Alamos, NM 87545	1	Science Applications, Inc. ATTN: R.B. Edelman 23146 Cumorah Crest Woodland Hills, CA 91364
1	National Science Foundation ATTN: A.B. Harvey Washington, DC 20550	3	SRI International ATTN: G. Smith D. Crosley D. Golden 333 Ravenswood Avenue Menlo Park, CA 94025
1	Olin Ordnance ATTN: V. McDonald, Library P.O. Box 222 St. Marks, FL 32355-0222	1	Stevens Institute of Tech. Davidson Laboratory ATTN: R. McAlevy, III Hoboken, NJ 07030
1	Paul Gough Associates, Inc. ATTN: P.S. Gough 1048 South Street Portsmouth, NH 03801-5423	1	Sverdrup Technology, Inc. LERC Group ATTN: R.J. Locke, MS SVR-2 2001 Aerospace Parkway Brook Park, OH 44142
2	Princeton Combustion Research Laboratories, Inc. ATTN: N.A. Messina M. Summerfield Princeton Corporate Plaza Bldg. IV, Suite 119 11 Deerpark Drive Monmouth Junction, NJ 08852	1	Sverdrup Technology, Inc. ATTN: J. Deur 2001 Aerospace Parkway Brook Park, OH 44142
1	Hughes Aircraft Company ATTN: T.E. Ward 8433 Fallbrook Avenue Canoga Park, CA 91303	1	Thiokol Corporation Elkton Division ATTN: S.F. Palopoli P.O. Box 241 Elkton, MD 21921

<u>No. of Copies</u>	<u>Organization</u>	<u>No. of Copies</u>	<u>Organization</u>
3	Thiokol Corporation Wasatch Division ATTN: S.J. Bennett P.O. Box 524 Brigham City, UT 84302	1	University of California, Berkeley Chemistry Department ATTN: C. Bradley Moore 211 Lewis Hall Berkeley, CA 94720
1	United Technologies Research Center ATTN: A.C. Eckbreth East Hartford, CT 06108	1	University of California, San Diego ATTN: F.A. Williams AMES, B010 La Jolla, CA 92093
1	United Technologies Corp. Chemical Systems Division ATTN: R.R. Miller P.O. Box 49028 San Jose, CA 95161-9028	2	University of California, Santa Barbara Quantum Institute ATTN: K. Schofield M. Steinberg Santa Barbara, CA 93106
1	Universal Propulsion Company ATTN: H.J. McSpadden 25401 North Central Avenue Phoenix, AZ 85027-7837	1	University of Colorado at Boulder Engineering Center ATTN: J. Daily Campus Box 427 Boulder, CO 80309-0427
1	Veritay Technology, Inc. ATTN: E.B. Fisher 4845 Millersport Highway P.O. Box 305 East Amherst, NY 14051-0305	2	University of Southern California Dept. of Chemistry ATTN: S. Benson C. Wittig Los Angeles, CA 90007
1	Brigham Young University Dept. of Chemical Engineering ATTN: M.W. Beckstead Provo, UT 84058	1	Cornell University Department of Chemistry ATTN: T.A. Cool Baker Laboratory Ithaca, NY 14853
1	California Institute of Tech. Jet Propulsion Laboratory ATTN: L. Strand/MS 125-224 4800 Oak Grove Drive Pasadena, CA 91109	1	University of Delaware ATTN: T. Brill Chemistry Department Newark, DE 19711
1	California Institute of Technology ATTN: F.E.C. Culick/MC 301-46 204 Karman Lab. Pasadena, CA 91125	1	University of Florida Dept. of Chemistry ATTN: J. Winefordner Gainesville, FL 32611
1	University of California Los Alamos Scientific Lab. P.O. Box 1663, Mail Stop B216 Los Alamos, NM 87545	3	Georgia Institute of Technology School of Aerospace Engineering ATTN: E. Price W.C. Strahle B.T. Zinn Atlanta, GA 30332

<u>No. of Copies</u>	<u>Organization</u>	<u>No. of Copies</u>	<u>Organization</u>
1	University of Illinois Dept. of Mech. Eng. ATTN: H. Krier 144MEE, 1206 W. Green St. Urbana, IL 61801	1	Purdue University School of Aeronautics and Astronautics ATTN: J.R. Osborn Grissom Hall West Lafayette, IN 47906
1	The Johns Hopkins University Chemical Propulsion Information Agency ATTN: T.W. Christian 10630 Little Patuxent Parkway, Suite 202 Columbia, MD 21044-3200	1	Purdue University Department of Chemistry ATTN: E. Grant West Lafayette, IN 47906
1	University of Michigan Gas Dynamics Lab Aerospace Engineering Bldg. ATTN: G.M. Faeth Ann Arbor, MI 48109-2140	2	Purdue University School of Mechanical Engineering ATTN: N.M. Laurendeau S.N.B. Murthy TSPC Chaffee Hall West Lafayette, IN 47906
1	University of Minnesota Dept. of Mechanical Engineering ATTN: E. Fletcher Minneapolis, MN 55455	1	Rensselaer Polytechnic Inst. Dept. of Chemical Engineering ATTN: A. Fontijn Troy, NY 12181
3	Pennsylvania State University Applied Research Laboratory ATTN: K.K. Kuo H. Palmer M. Micci University Park, PA 16802	1	Stanford University Dept. of Mechanical Engineering ATTN: R. Hanson Stanford, CA 94305
1	Pennsylvania State University Dept. of Mechanical Engineering ATTN: V. Yang University Park, PA 16802	1	University of Texas Dept. of Chemistry ATTN: W. Gardiner Austin, TX 78712
1	Polytechnic Institute of NY Graduate Center ATTN: S. Lederman Route 110 Farmingdale, NY 11735	1	Virginia Polytechnic Institute and State University ATTN: J.A. Schetz Blacksburg, VA 24061
2	Princeton University Forrestal Campus Library ATTN: K. Brezinsky I. Glassman P.O. Box 710 Princeton, NJ 08540	1	Freedman Associates ATTN: E. Freedman 2411 Diana Road Baltimore, MD 21209-1525

USER EVALUATION SHEET/CHANGE OF ADDRESS

This Laboratory undertakes a continuing effort to improve the quality of the reports it publishes. Your comments/answers to the items/questions below will aid us in our efforts.

1. ARL Report Number ARL-TR-62 Date of Report February 1993

2. Date Report Received _____

3. Does this report satisfy a need? (Comment on purpose, related project, or other area of interest for which the report will be used.) _____

4. Specifically, how is the report being used? (Information source, design data, procedure, source of ideas, etc.) _____

5. Has the information in this report led to any quantitative savings as far as man-hours or dollars saved, operating costs avoided, or efficiencies achieved, etc? If so, please elaborate. _____

6. General Comments. What do you think should be changed to improve future reports? (Indicate changes to organization, technical content, format, etc.) _____

**CURRENT
ADDRESS**

Organization

Name

Street or P.O. Box No.

City, State, Zip Code

7. If indicating a Change of Address or Address Correction, please provide the Current or Correct address above and the Old or Incorrect address below.

**OLD
ADDRESS**

Organization

Name

Street or P.O. Box No.

City, State, Zip Code

(Remove this sheet, fold as indicated, staple or tape closed, and mail.)