

SAHYSMOD

SPATIAL AGRO-HYDRO-SALINITY MODEL

Windows version

**DESCRIPTION OF PRINCIPLES, USER MANUAL, AND
CASE STUDIES**

On website www.waterlog.info/sahysmod.htm

SAHYSMOD working group of ILRI

International Institute for Land Reclamation and Improvement (ILRI), P.O.Box 45, 6700 AA
Wageningen, The Netherlands

TABLE OF CONTENTS

1. INTRODUCTION	1
2. PRINCIPLES	2
2.1. Model components	2
2.2. Polygonal network	2
2.3. Seasonal approach	3
2.4. Computational time steps	3
2.5. Hydrological data	3
2.6. Cropping patterns/rotations	4
2.7. Soil strata	4
2.8. Agricultural water balances	5
2.9. Ground water flow	5
2.10 Drains, wells, and re-use	6
2.11 Salt balances	6
2.12 Farmers' responses	7
2.13 Annual input changes	7
2.14 Output data	8
2.15 Other users' suggestions	8
3. AGRICULTURAL WATER BALANCES	9
3.1. The reservoir concept	9
3.1.1. The surface reservoir	10
3.1.2. The root zone	10
3.1.3. The transition zone	11
3.1.4. The aquifer	11
3.1.5. Topsoil water balance	12
3.1.6. Subsoil water balance	12
3.1.7. Agronomic water balance	12
3.1.8. Geo-hydrologic water balance	13
3.1.9. Overall water balance	13
3.2. Model calculations for water balances	14
3.3. Capillary rise and actual evapo-transpiration	17
3.3.1. Depth of the water table and capillary rise factor	17
3.3.2. Potential evapo-transpiration and moisture deficit	18
3.3.3. Apparent capillary rise and actual evapo-transpiration	18
3.3.4. Capillary rise	19
3.4. The subsurface drainage	19
3.5. Water balance of the transition zone	21
3.6. Irrigation efficiencies and sufficiencies	22

4	GROUND WATER FLOW	24
4.1	Finite difference method	24
4.2.	Incoming and outgoing ground water flow	25
4.2.1	Flow between two unconfined aquifers	25
4.2.2	Flow between two semi-confined aquifers	27
4.2.3	Flow between unconfined and semi confined aquifers	29
4.2.4	Inflow and outflow per polygon	30
4.2.5	Vertical flow in semi-confined aquifers	31
4.3	Inflow of salt	31
4.4	Change of ground water level	32
4.5	Seasonal values	32
4.6	Possibilities of and conditions for application	33
5.	SALT BALANCES	35
5.1.	Change in salt content	35
5.2.	Salt balances under full cropping rotation	35
5.2.1.	Above the soil surface	36
5.2.2.	Root zone	37
5.2.3.	Transition zone	39
5.2.4.	Aquifer	40
5.2.5.	Salt concentration of drain and well water	41
5.3.	Salt balances under zero cropping rotation	41
5.3.1.	Above the soil surface	41
5.3.2.	Root zone	42
5.3.3.	Transition zone	43
5.4.	Salt balances under intermediate cropping rotations	43
5.4.1.	Types of cropping rotation	43
5.4.2.	Part of the area permanently non-irrigated, $K_r=1$	44
5.4.3.	Part of the irrigated area permanently under group A crop(s), $K_r=2$	46
5.4.4.	Part of the irrigated area permanently under group B crop(s), $K_r=3$	48
6.	SPATIAL FREQUENCY DISTRIBUTION OF SOIL SALINITY	52
7.	FARMERS' RESPONSES	54
7.1.	Reduction of irrigated area when salinization or irrigation deficiency occurs	54
7.2.	Reduction of irrigation when water logging occurs and adjusting the bypass accordingly	56
7.3.	Reduction of ground-water abstraction by pumping from wells when the water table drops	57
8.	ALPHABETICAL LIST OF SYMBOLS	58
9.	USER MENU	68
	(User menu is not anymore described, as the Windows version is self-explanatory)	
10	LIST OF SYMBOLS OF INPUT DATA	69

11 LIST OF SYMBOLS OF OUTPUT DATA	72
12 EXERCISE ICMALD	75
12.1 Introduction	75
12.2 Input	75
12.3 1st Inspection of the output	78
12.4 Canal lining	80
12.5 Interceptor drain	80
12.6 Salt movement in the ground water	81
12.7 Checking the drainage flow by hand	81
12.8 Checking the capillary rise by hand	82
12.9 Checking the ground water flow by hand	83
13 CASE STUDY HANSI FARM	86
13.1 Introduction	86
13.2 Aquifer recharge	87
13.3 Further investigations (to be completed)	89

1. INTRODUCTION

Sahysmod is a computer program for the prediction of the salinity of soil moisture, ground water and drainage water, the depth of the water table, and the drain discharge in irrigated agricultural lands, using different (geo) hydrologic conditions, varying water management options, including the use of ground water for irrigation, and several cropping rotation schedules, whereby the spatial variations are accounted for through a network of polygons.

Sahysmod combines the agro-hydro-salinity model Sahysmod (Oosterbaan 1998) and the nodal (polygonal) ground water model SGMP (Boonstra and de Ridder 1981). The combination was made by K.V.G.K. Rao with guidance from J. Boonstra and R.J. Oosterbaan, the user menu by H. Ramnandanlal, R.A.L. Kselik and R. J. Oosterbaan to facilitate the management of input and output data. These five persons formed the Sahysmod working group of ILRI with Oosterbaan as coordinator and editor. He also rebuilt the program to reduce the computer memory requirements and to increase the maximum number of polygons.

The calculation programs were elaborated in Fortran and later a user shell was developed in TurboPascal. Now the program is written in Delphi to make it a Windows version.

The program was designed keeping in mind a relative simplicity of operation to promote its use by field technicians and project planners. It aims at using input data that are generally available, or that can be estimated with reasonable accuracy, or that can be measured with relative ease.

The program can be downloaded from www.waterlog.info/sahysmod.htm
To start the program click on 'SahysMod.exe'.

2. PRINCIPLES

2.1. Model components

The study area is divided into a nodal network of triangles, rectangles, or any other polygons with a maximum of 6 sides. The model consists further of three parts:

1. An agronomic water balance model, which calculates for each polygon the downward and/or upward water fluxes in the soil profile depending on the fluctuations of the water table;
2. A ground water model of the aquifer, which calculates the ground-water flows into and from each polygon and the ground-water levels per polygon depending on the upward and/or downward water fluxes. The parts 1 and 2 are interactive as they influence each other.
3. A salt balance model, which runs parallel to the water, balance model and determines the salt concentrations in the soil profile, and of the drainage, well and ground water.

These parts are discussed in sect. 3, 4 and 5 respectively. Some features of general importance are mentioned below.

2.2. Polygonal network

The model permits a maximum of 240 internal and 120 external polygons (total 360) with a minimum of 3 and a maximum of 6 sides each. A slower model handling a total of 540 polygons (360 internal, 180 external) is also available.

The subdivision of the area into polygons, based on nodal points with known coordinates, should be governed by the characteristics of the distribution of the cropping, irrigation, drainage and ground water characteristics over the study area.

The nodes must be numbered, which can be done at will. With an index one indicates whether the node is internal or external. Nodes can be added and removed at will or changed from internal to external or vice versa. Through another index one indicates whether the internal nodes have an unconfined or semi-confined aquifer. This can also be changed at will.

Nodal network relations are to be given indicating the neighboring polygon numbers of each node. The program then calculates the surface area of each polygon, the distance between the nodes and the length of the sides between them using the Thiessen principle.

Hydraulic conductivity can vary for each side of the polygons.

The depth of the water table, the rainfall and salt concentrations of the deeper layers are assumed to be the same over the whole polygon. Other parameters can vary within the polygons according to type of crops and cropping rotation schedule (sect. 2.5).

2.3. Seasonal approach

The model is based on seasonal input data and returns seasonal outputs. The number of seasons per year can be chosen between a minimum of one and a maximum of four. One can distinguish for example dry, wet, cold, hot, irrigation or fallow seasons. Reasons of not using smaller input/output periods are:

- short-term (e.g. daily) inputs would require much information ,which, in large areas, may not be readily available;
- short-term outputs would lead to immense output files ,which would be difficult to manage and interpret;
- this model is especially developed to predict long term trends, and predictions for the future are more reliably made on a seasonal (long term) than on a daily (short term) basis, due to the high variability of short term data;
- though the precision of the predictions for the future may be limited, a lot is gained when the trend is sufficiently clear. For example, it need not be a major constraint to the design of appropriate salinity control measures when a certain salinity level, predicted by Sahysmod to occur after 20 years, will in reality occur after 15 or 25 years.

2.4. Computational time steps

Many water-balance factors depend on the level of the water table, which again depends on some of the water-balance factors. Due to these mutual influences there can be non-linear changes throughout the season. Therefore, the computer program performs daily calculations. For this purpose, the seasonal water-balance factors given with the input are reduced automatically to daily values. The calculated seasonal water-balance factors, as given in the output, are obtained by summations of the daily calculated values. Ground-water levels and soil salinity (the state variables) at the end of the season are found by accumulating the daily changes of water and salt storage.

In some cases the program may detect that the time step must be taken less than 1 day for better accuracy. The necessary adjustments are made automatically.

2.5. Hydrological data

The method uses seasonal water balance components as input data. These are related to the surface hydrology (like rainfall, potential evaporation, irrigation, use of drain and well water for irrigation, runoff), and the aquifer hydrology (e.g. pumping from wells). The other water balance components (like actual evaporation, downward percolation, upward capillary rise, subsurface drainage, ground water flows) are given as output. The quantity of drainage water, as output, is determined by two drainage intensity factors for drainage above and below drain level respectively (to be given with the input data) and the height of the water table above the given drain level. This height results from the computed water balance. Further, a drainage reduction factor can be applied to simulate a limited operation of the drainage system. Variation of the drainage intensity factors and the drainage reduction factor gives the opportunity to simulate the impact of different drainage options.

To obtain accuracy in the computations of the ground water flow (sect. 2.8), the actual evaporation and the capillary rise, the computer calculations are done on a daily basis. For this

purpose, the seasonal hydrological data are divided by the number of days per season to obtain daily values. After the seasonal computations, the hydrological components are totaled.

2.6. Cropping patterns/rotations

The input data on irrigation, evaporation, and surface runoff are to be specified per season for three kinds of agricultural practices, which can be chosen at the discretion of the user:

- A: irrigated land with crops of group A
- B: irrigated land with crops of group B
- U: non-irrigated land with rain-fed crops or fallow land

The groups, expressed in fractions of the total area, may consist of combinations of crops or just of a single kind of crop. For example, as the A-type crops one may specify the lightly irrigated cultures, and as the B type the more heavily irrigated ones, such as sugar cane and rice. But one can also take A as rice and B as sugar cane, or perhaps trees and orchards. A, B and/or U crops can be taken differently in different seasons, e.g. A=wheat plus barley in winter and A=maize in summer while B=vegetables in winter and B=cotton in summer. Non-irrigated land can be specified in two ways: (1) as $U=1-A-B$ and (2) as A and/or B with zero irrigation. A combination can also be made.

Further, a specification must be given of the seasonal rotation of the different land uses over the total area, e.g. full rotation, no rotation at all, or incomplete rotation. This occurs with a rotation index. The rotations are taken over the seasons within the year. To obtain rotations over the years it is advisable to introduce annual input changes as explained in sect. 2.13.

When a fraction A_1 , B_1 and/or U_1 differs from the fraction A_2 , B_2 and/or U_2 in another season, because the irrigation regime changes in the different seasons, the program will detect that a certain rotation occurs. If one wishes to avoid this, one may specify the same fractions in all seasons ($A_2=A_1$, $B_2=B_1$, $U_2=U_1$) but the crops and irrigation quantities may be different and may need to be proportionally adjusted. One may even specify irrigated land (A or B) with zero irrigation, which is the same as un-irrigated land (U).

Cropping rotation schedules vary widely in different parts of the world. Creative combinations of area fractions, rotation indices, irrigation quantities and annual input changes can accommodate many types of agricultural practices.

Variation of the area fractions and/or the rotational schedule gives the opportunity to simulate the impact of different agricultural practices on the water and salt balance.

2.7. Soil strata

Sahysmod accepts four different reservoirs of which three are in the soil profile:

- s: a surface reservoir
- r: an upper (shallow) soil reservoir or root zone
- x: an intermediate soil reservoir or transition zone
- q: a deep reservoir or main aquifer.

The upper soil reservoir is defined by the soil depth, from which water can evaporate or be taken up by plant roots. It can be taken equal to the root zone. It can be saturated, unsaturated,

or partly saturated, depending on the water balance. All water movements in this zone are vertical, either upward or downward, depending on the water balance. (In a future version of Sahysmod, the upper soil reservoir may be divided into two equal parts to detect the trend in the vertical salinity distribution.)

The transition zone can also be saturated, unsaturated or partly saturated. All flows in this zone are horizontal, except the flow to subsurface drains, which is radial.

If a horizontal subsurface drainage system is present, this must be placed in the transition zone, which is then divided into two parts: an upper transition zone (above drain level) and a lower transition zone (below drain level).

If one wishes to distinguish an upper and lower part of the transition zone in the absence of a subsurface drainage system, one may specify in the input data a drainage system with zero intensity.

The aquifer has mainly horizontal flow. Pumped wells, if present, receive their water from the aquifer only. The flow in the aquifer is determined in dependence of spatially varying depths of the aquifer, levels of the water table, and hydraulic conductivity.

SAHYSMOD permits the introduction of phreatic (unconfined) and semi-confined aquifers. The latter may develop a hydraulic over or under pressure below the slowly permeable top-layer (aquitarde).

2.8. Agricultural water balances

The agricultural water balances are calculated for each soil reservoir separately. The excess water leaving one reservoir is converted into incoming water for the next reservoir. The three soil reservoirs can be assigned different thickness and storage coefficients, to be given as input data. When, in a particular situation the transition zone or the aquifer is not present, they must be given a minimum thickness of 0.1 m.

The depth of the water table at the end of the previous time step, calculated from the water balances, is assumed to be the same within each polygon. If this assumption is not acceptable, the area must be divided into a larger number of polygons.

Under certain conditions, the height of the water table influences the water-balance components. For example a rise of the water table towards the soil surface may lead to an increase of capillary rise, actual evaporation, and subsurface drainage, or a decrease of percolation losses. This, in turn, leads to a change of the water-balance, which again influences the height of the water table, etc. This chain of reactions is one of the reasons why Sahysmod has been developed into a computer program, in which the computations are made day by day to account for the chain of reactions with a sufficient degree of accuracy.

2.9. Ground water flow

The model calculates the ground water levels and the incoming and outgoing ground water flows between the polygons by a numerical solution of the well-known Boussinesq equation. The levels and flows influence each other mutually.

The ground water situation is further determined by the vertical recharge that is calculated from the agronomic water balances. These depend again on the levels of the ground water

When semi-confined aquifers are present, the resistance to vertical flow in the slowly permeable top-layer and the overpressure in the aquifer, if any, are taken into account.

Hydraulic boundary conditions are given as hydraulic heads in the external nodes in combination with the hydraulic conductivity between internal and external nodes. If one wishes to impose a zero flow condition at the external nodes, the conductivity can be set at zero.

Further, aquifer flow conditions can be given for the internal nodes. These are required when a geological fault line is present at the bottom of the aquifer or when flow occurs between the main aquifer and a deeper aquifer separated by a semi-confining layer.

2.10 Drains, wells, and re-use

The sub-surface drainage can be accomplished through drains or pumped wells.

The subsurface drains, if any, are characterized by drain depth and drainage capacity. The drains are located in the transition zone. The subsurface drainage facility can be applied to natural or artificial drainage systems. The functioning of an artificial drainage system can be regulated through a drainage control factor.

By installing a drainage system with zero capacity one obtains the opportunity to have separate water and salt balances in the transition above and below drain level.

The pumped wells, if any, are located in the aquifer. Their functioning is characterized by the well discharge.

The drain and well water can be used for irrigation through a (re)use factor. This may have an impact on the water and salt balance and on the irrigation efficiency or sufficiency.

2.11 Salt balances

The salt balances are calculated for each soil reservoir separately. They are based on their water balances, using the salt concentrations of the incoming and outgoing water. Some concentrations must be given as input data, like the initial salt concentrations of the water in the different soil reservoirs, of the irrigation water and of the incoming ground water in the aquifer. The concentrations are expressed in terms of electric conductivity (EC in dS/m). When the concentrations are known in terms of g salt/l water, the rule of thumb: 1 g/l -> 1.7 dS/m can be used. Usually, salt concentrations of the soil are expressed in EC_e, the electric conductivity of an extract of a saturated soil paste. In Sahysmod, the salt concentration is expressed as the EC of the soil moisture when saturated under field conditions. As a rule, one can use the conversion rate $EC : EC_e = 2 : 1$.

Salt concentrations of outgoing water (either from one reservoir into the other or by subsurface drainage) are computed on the basis of salt balances, using different leaching or salt mixing efficiencies to be given with the input data. The effects of different leaching efficiencies can be simulated varying their input value.

If drain or well water is used for irrigation, the method computes the salt concentration of the mixed irrigation water in the course of the time and the subsequent impact on the soil and ground water salinity, which again influences the salt concentration of the drain and well water. By varying the fraction of used drain or well water (through the input), the long term impact of different fractions can be simulated.

The dissolution of solid soil minerals or the chemical precipitation of poorly soluble salts is not included in the computation method. However, but to some extent, it can be accounted for through the input data, e.g. increasing or decreasing the salt concentration of the irrigation water or of the incoming water in the aquifer. In a future version, the precipitation of gypsum may be introduced.

2.12 Farmers' responses

If required, farmers' responses to water logging and salinity can be automatically accounted for. The method can gradually decrease:

1. the amount of irrigation water applied when the water table becomes shallower depending on the kind of crop (paddy rice and non-rice)
2. the fraction of irrigated land when the available irrigation water is scarce;
3. the fraction of irrigated land when the soil salinity increases; for this purpose, the salinity is given a stochastic interpretation;
4. the ground-water abstraction by pumping from wells when the water table drops.

The farmers' responses influence the water and salt balances, which, in turn, slows down the process of water logging and salinization. Ultimately a new equilibrium situation will arise.

The user can also introduce farmers' responses by manually changing the relevant input data. Perhaps it will be useful first to study the automatic farmers' responses and their effect first and thereafter decide what the farmers' responses will be in the view of the user.

2.13 Annual input changes

The program runs either with fixed input data for the number of years determined by the user. This option can be used to predict future developments based on long-term average input values, e.g. rainfall, as it will be difficult to assess the future values of the input data year by year.

The program also offers the possibility to follow historic records with annually changing input values (e.g. rainfall, irrigation, cropping rotations), the calculations must be made year by year. If this possibility is chosen, the program creates a transfer file by which the final conditions of the previous year (e.g. water table and salinity) are automatically used as the initial conditions for the subsequent period. This facility makes it also possible to use various generated rainfall sequences drawn randomly from a known rainfall probability distribution and to obtain a stochastic prediction of the resulting output parameters.

Some input parameters should not be changed, like the nodal network relations, the system geometry, the thickness of the soil layers, and the total porosity, otherwise illogical jumps occur in the water and salt balances. These parameters are also stored in the transfer file, so that any impermissible change is overruled by the transfer data. In some cases of incorrect changes, the program will stop and request the user to adjust the input.

2.14 Output data

The output is given for each season of any year during any number of years, as specified with the input data. The output data comprise hydrological and salinity aspects. The data are filed in the form of tables that can be inspected directly, through the user menu, that calls selected groups of data either for a certain polygon over time, or for a certain season over the polygons. Also, the program has the facility to store the selected data in a spreadsheet format for further analysis and for import into a mapping program. A user interface to assist with the production of maps of output parameters is still in development.

The program offers only a limited number of standard graphics, as it is not possible to foresee all different uses that may be made. This is the reason why the possibility for further analysis through spreadsheet program was created. The interpretation of the output is left entirely to the judgment of the user.

2.15 Other users' suggestions

The program offers the possibility to develop a multitude of relations between varied input data, resulting outputs and time. Different users may wish to establish different cause and effect or correlation relationships.

If the user wishes to determine the effect of variations of a certain parameter on the value of other parameters, the program must be run repeatedly according to a user-designed scenario. This procedure can be used for the calibration of the model or for the simulation runs.

Some of the input data are inter-dependent. These data can, therefore, not be indiscriminately varied. In very obvious illogical combinations of data, the program will give a warning. The correctness of the input remains the responsibility of the user.

Although the computations are done on a daily basis, all the seasonal end-results can be checked by hand with the equations given in the following sections because all output results are based on weighed seasonal averages.

The size of the total area and the individual polygons can be determined at will by the user. When the topography and other conditions are fairly uniform, the total size of the area can be taken quite large, say 100 000 ha or more. For sloping or undulating lands, it deserves recommendation to use smaller areas. If necessary, the total area can be divided into sub-areas to which Sahysmod can be applied separately.

It is of course also possible to use Sahysmod in smaller areas of 100 ha or less. In such areas fine-tuning of the model is feasible.

The exercise and case study (given in sect. 12 and 13) refer to relatively small areas. Otherwise the examples would become too elaborate.

3. AGRICULTURAL WATER BALANCES

3.1. The reservoir concept

The principles of the agronomic water balances are illustrated in fig. 3.1, where the four soil reservoirs are shown on which the model is built:

1. the surface reservoir,
2. the root zone,
3. the transition zone,
4. the aquifer.

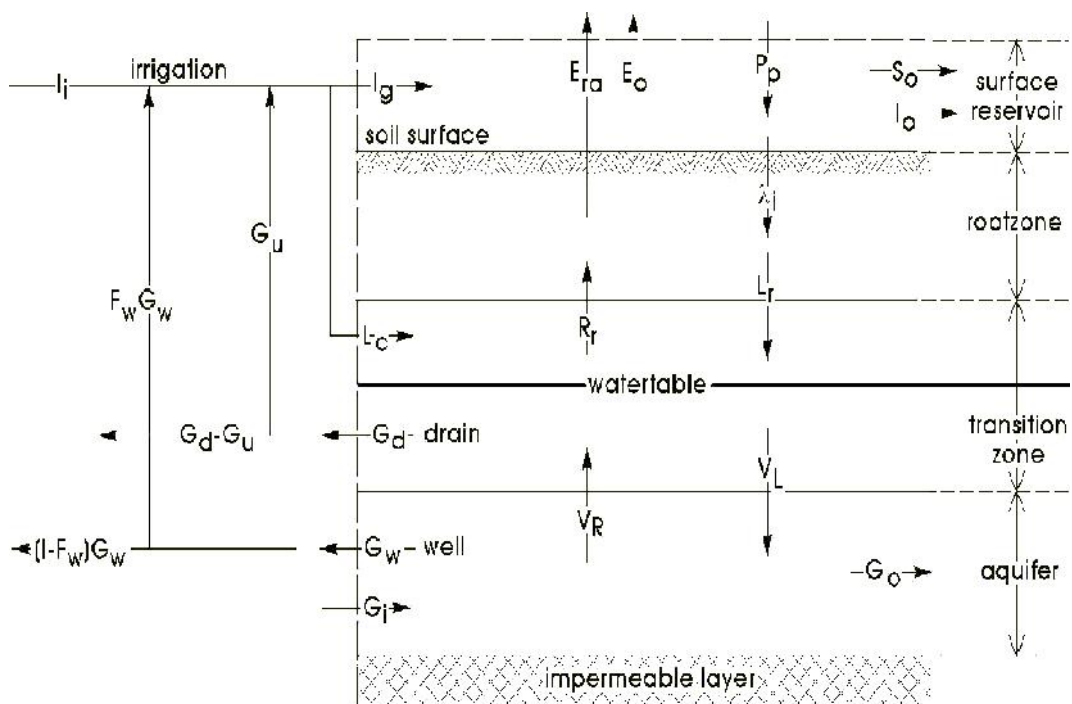

Figure 3.1 Concept of 4 soil reservoirs with hydrological inflow and outflow components

For each reservoir a water balance can be made with the hydro-logic components. All quantities of the components are expressed as seasonal volumes per unit surface area, giving a seasonal depth of water.

A water balance is based on the principle of the conservation of mass for boundaries defined in space and time and can be written as:

$$\text{Inflow} = \text{Outflow} + \text{Storage} \quad (3.1)$$

When the storage is positive the water content increases and, when negative (i.e. there is depletion instead of storage), it decreases.

In fig. 3.1 it is assumed that all balance factors are uniformly distributed over the area and that the water table remains within the transition zone. They represent a particular case of Sahysmod. In later sections, adjustments to other conditions are made.

Sahysmod converts the seasonal input values of hydrological components into daily values using the length of the season in days. Computations are done day by day as the water table and the hydrological components may have a mutual influence leading to non-linear reactions. The output file gives the summation of the calculated water balance factors over the duration of the season. Sometimes, when required for better accuracy, the program takes time steps of half a day or less.

3.1.1. The surface reservoir

The surface reservoir is located on top of the soil. The water balance of the surface reservoir for a certain period reads:

$$P_p + I_g + \lambda_o = E_o + \lambda_i + S_o + \Delta W_s \quad (3.2)$$

where P_p is the amount of water vertically reaching the soil surface, such as precipitation and sprinkler irrigation, I_g is the gross irrigation inflow including the natural surface inflow and the drain and well water used for irrigation, but excluding the percolation losses from the canal system, E_o is the amount of evaporation from open water, λ_i is the amount of water infiltrated through the soil surface into the root zone, λ_o is the amount of water ex-filtrated through the soil surface from the root zone, S_o is the amount of surface runoff or surface drainage leaving the area, and ΔW_s is the change in amount of water stored in the surface reservoir.

The term λ_o is not shown in fig. 3.1 as can occur only when the water table is above the soil surface.

3.1.2. The root zone

The root zone corresponds to the depth of soil from which evapo-transpiration takes place. Its water balance reads:

$$\lambda_i + R_r = \lambda_o + E_{ra} + L_r + \Delta W_f + \Delta W_r \quad (3.3)$$

where: R_r is the amount of capillary rise into the root zone, E_{ra} is the amount of actual evapo-transpiration from the root zone, L_r is the amount of percolation losses from the root zone, ΔW_f is the storage of moisture in the root zone between field capacity and wilting point, and ΔW_r is the storage of water in the root zone between field capacity and full saturation.

The factor R_r is the opposite of L_r and these components cannot occur simultaneously, i.e. when $R_r > 0$ then $L_r = 0$ and vice versa.

When water balances are made for fairly long periods of time, for instance a season or a year, the storage ΔW_f is often negligibly small compared to the other hydrological components. In Sahysmod, therefore, this storage is set equal to zero and the water balance changes to:

$$\lambda_i + R_r = \lambda_o + E_{ra} + L_r + \Delta W_r \quad (3.4)$$

3.1.3. The transition zone

The transition zone is the zone between root zone and aquifer. Its lower limit can be fixed in different ways according to local conditions:

- a at the interface between a clay layer on top of a sandy layer;
- b at the annually greatest depth to water table;
- c at the greatest depth to which the influence of a subsurface drainage system extends;
- d at the depth where horizontal ground water flow is converted into vertical flow of ground water or vice versa.

The water balance of the transition zone reads:

$$L_r + L_c + V_R + G_{ti} = R_r + V_L + G_d + G_{to} + \Delta W_x \quad (3.5)$$

where: L_c is the percolation loss from the irrigation canal system, V_R is the amount of vertical upward seepage from the aquifer into the transition zone, G_{ti} is the horizontally incoming flow of ground water, V_L is the amount of vertical downward drainage from the saturated transition zone to the aquifer, G_{to} is the horizontally outgoing flow of ground water, G_d is the total amount of natural or artificial drainage of ground water to ditches or pipe drains, and ΔW_x is the water storage in the transition zone between field capacity and wilting point.

The component V_R is the opposite of V_L and these cannot occur simultaneously, i.e. when $V_R > 0$ then $V_L = 0$ and vice versa.

The factors G_{ti} , G_{to} and ΔW_q are determined by the ground-water model (sect. 4), which uses the values of V_L , and V_R .

3.1.4. The aquifer

The water balance of the aquifer can be written as:

$$G_{qi} + Q_{inf} + V_L = G_{qo} + Q_{out} + V_R + G_w + \Delta W_q \quad (3.6)$$

where: G_{qi} is the amount horizontal ground water inflow through the main aquifer, G_{qo} is the amount of horizontal ground water outflow through the aquifer, Q_{inf} is an inflow condition of ground water (either through a geologic fault at the bottom of the aquifer or from a deeper aquifer through the bottom when this is semi-pervious), Q_{out} is an outflow condition of ground water (either through a geologic fault at the bottom of the aquifer or into a deeper aquifer through the bottom when this is semi-pervious), G_w is the amount ground water pumped from the aquifer through wells, and ΔW_q is the ground water storage in the aquifer.

The factors G_{qi} , G_{qo} and ΔW_q are determined by the ground-water model (sect. 4), which uses the values of V_L , V_R and G_w .

3.1.5. Topsoil water balance

When the water table is in the transition zone, the balances of the surface reservoir and the root zone may be combined into the topsoil water-balance, by adding eqn. 3.2 and 3.3:

$$P_p + I_g + L_c = E_a + I_o + S_o + \Delta W_r + \Delta W_x \quad (3.7)$$

with:

$$E_a = E_o + E_{ra} \quad (3.8)$$

where E_a is the total actual evapo-transpiration.

In the topsoil water-balance, the in-filtration λ_i and the ex-filtration λ_o are not present. The same holds for the components R_r and L_r . All these components represent vertical flows linking the two reservoirs.

Using:

$$I_f = I_g - I_o \quad (3.9)$$

$$V_s = P_p + I_f - S_o \quad (3.10)$$

where V_s represents the total surface-water resource and I_f is the net field irrigation, eqn. 3.7 can be reduced to:

$$V_s + I_f + L_c = E_a + \Delta W_r + \Delta W_x \quad (3.11)$$

3.1.6. Subsoil water balance

When the water table is in the root zone, the capillary rise R_r and percolation L_r do not exist, because the transition zone is saturated. Also, the values of ΔW_x and ΔW_q are zero. Thus it is preferable to combine the water balances of root zone, transition zone and aquifer, giving the subsoil water-balance:

$$\lambda_i + L_c + G_{ti} + G_{qi} + Q_{inf} = \lambda_o + E_{ra} + G_{to} + G_{qo} + Q_{out} + G_d + G_w + \Delta W_r \quad (3.12)$$

3.1.7. Agronomic water balance

When the water table is in the aquifer, the root zone and transition zone are unsaturated and the components V_R and V_L have to be replaced by R_r and L_r . Thus, it is preferable to combine the water balances of the surface reservoir, root zone and transition zone, giving the agronomic water-balance:

$$P_p + I_g + L_c + G_{ti} = I_o + S_o + E_a + G_d + G_{to} + \Delta W_s + \Delta W_r + \Delta W_x \quad (3.13)$$

3.1.8. Geo-hydrologic water balance

With a water table in the transition zone, the balances of the transition zone and aquifer can be combined into the geo-hydrologic water balance, in which the storage ΔW_q may be considered zero as the aquifer is fully saturated:

$$L_r + L_c + G_{ti} + G_{qi} + Q_{inf} = R_r + G_{to} + G_{qo} + Q_{out} + G_d + G_w + \Delta W_x \quad (3.14)$$

Here, the linkage components V_R and V_L have vanished.

3.1.9. Overall water balance

When the water table remains above the soil surface, the values of ΔW_r , ΔW_x and ΔW_q are zero, as the soil is fully saturated. When, in addition, the water flows from the subsoil into the surface reservoir, the in-filtration (λ_i) becomes negative. Thus, it is preferable to combine the water balances of all the reservoirs:

$$P_p + I_g + L_c + G_{ti} + G_{qi} + Q_{inf} = E_a + I_o + S_o + G_{to} + G_{qo} + Q_{out} + G_d + G_w + \Delta W_s \quad (3.15)$$

In this overall water balance, all linkage components have disappeared.

3.2. Model calculations for water balances

Sahysmod accepts maximum four seasons, whose duration is expressed in months. The total duration of the seasons is 12 months. During the year, the agricultural land use may change from season to season and the distribution of the water resources depends on the agricultural land use. To accommodate the rotational land use, Sahysmod distinguishes 3 types of land use (fig. 3.2):

- A: irrigated land under group A crops
- B: irrigated land under group B crops
- U: non-irrigated land (U)

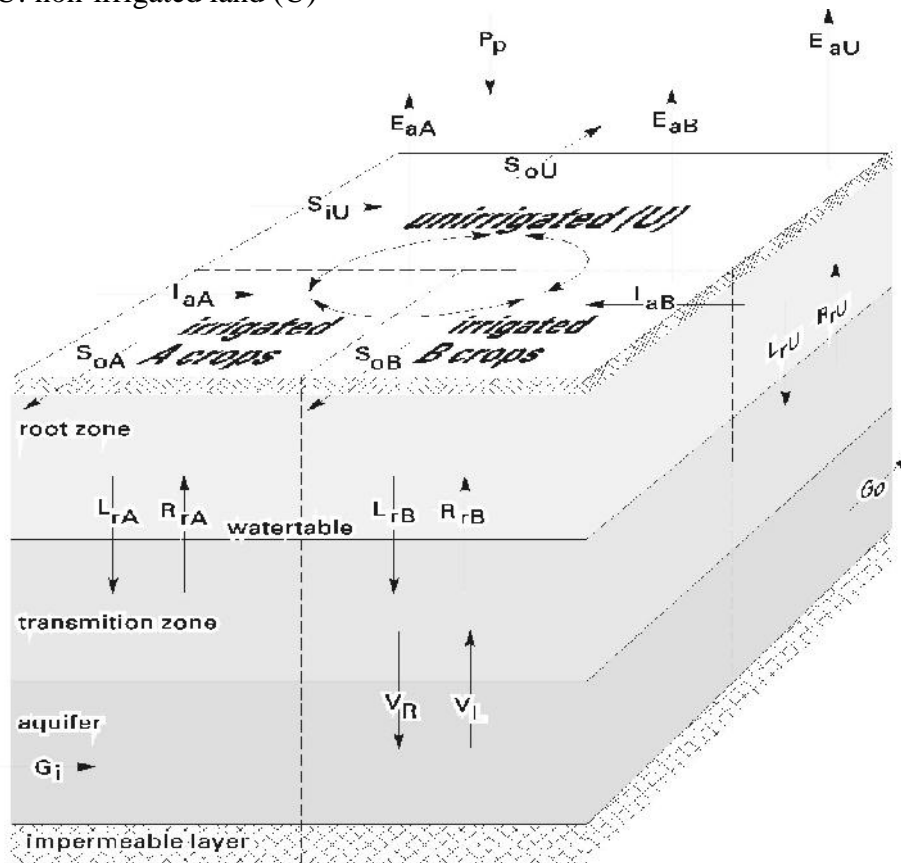

Figure 3.2 Three types of rotated agricultural land use (A, B, and U) with the different hydrological factors involved.

The distinction between group A and B crops is made to introduce the possibility of having lightly and heavily irrigated crops. Examples of the second kind are submerged rice and sugar cane. The latter crop may occupy more than one season. The distinction also gives the possibility to introduce permanent instead of seasonal crops like orchards. The non-irrigated land may consist of rain-fed crops and temporary or permanently fallow land.

Each land use type is determined by an area fraction A, B, and U respectively. The sum of the fractions equals unity:

$$A + B + U = 1 \quad (3.16)$$

The total field irrigation I_f (expressed in m^3 per m^2 total area) of eqn. 3.9 can also be written as:

$$I_f = I_{aA}A + I_{aB}B \quad (3.17)$$

where (fig. 3.3): I_{aA} and I_{aB} are the field irrigation applications to the areas under group A and B crops respectively (m^3 per m^2 area under A and B crops respectively).

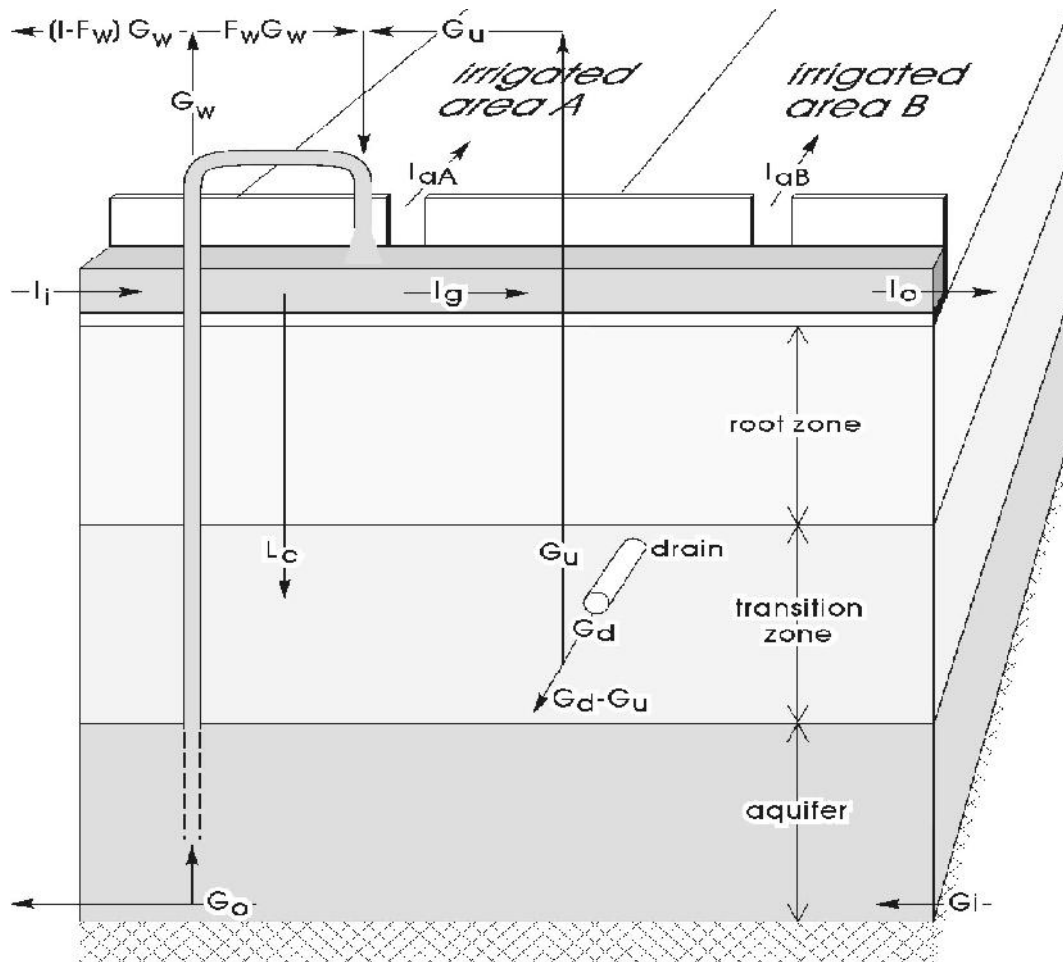

Figure 3.3 Water-balance factors of the canal, drain and well systems.

The quantity of irrigation water or surface flow entering the area I_i (m^3 per m^2 total area) is found from:

$$I_i = I_f + I_o + L_c - F_w G_w - G_u \quad (3.18)$$

where: F_w is the fraction of the pumped well water G_w used for irrigation, and G_u is the quantity of subsurface drainage water used for irrigation (m^3 per m^2 total area).

The total percolation from the root zone L_{rT} (m^3 per m^2 total area) is calculated from:

$$L_{rT} = L_{rA}A + L_{rB}B + L_{rU}U \quad (3.19)$$

where: L_{rA} , L_{rB} , and L_{rU} are the amounts of percolation from the root zone of the A, B and U land respectively (m^3 per m^2 area of A and B and U land respectively), and:

$$L_{rA} = V_A - E_{aA} \quad (3.19a)$$

$$L_{rB} = V_B - E_{aB} \quad (3.19b)$$

$$L_U = V_U - E_{aU} \quad (3.19c)$$

where: V_A , V_B , V_U are the amounts of surface water resources of the A, B, and U land respectively, E_{aA} , E_{aB} , and E_{aU} are the amounts of actual evapo-transpiration of the A, B and U land respectively. All units are in m^3 per m^2 area of A and B and U land respectively.

The total surface water resources V_s (m^3 per m^2 total area) in eqn. 10 can also be calculated from:

$$V_s = V_A A + V_B B + V_U U \quad (3.20)$$

where:

$$V_A = P_p + I_{iA} - S_{oA} \quad (3.20a)$$

$$V_B = P_p + I_{iB} - S_{oB} \quad (3.20b)$$

$$V_U = P_p + S_{iU} - S_{oU} \quad (3.20c)$$

where: V_A , V_B , V_U are the site specific surface water resources of the A, B, and U land respectively (m^3 per m^2 area of A and B and U land respectively), and S_{oA} , S_{oB} , S_{oU} are the amounts of surface runoff or surface drainage from the A, B, and U land respectively (m^3 per m^2 area of A and B and U land respectively).

The capillary rise R_r depends on atmospheric demand, characterized by the potential evapo-transpiration E_p , available water V_s , and depth of water table D_w . The processes and calculations involved are described in sect. 3.3. With the results obtained, the total capillary rise R_{rT} (m^3 per m^2 total area) can be determined as:

$$R_{rT} = R_{rA}A + R_{rB}B + R_{rU}U \quad (3.21)$$

where: R_{rA} , R_{rB} , and R_{rU} are the amounts of capillary rise into the root zone of the A, B, and U land respectively (m^3 per m^2 area of A and B and U land respectively).

The actual evapo-transpiration E_a depends on atmospheric demand and is characterized by the potential evapo-transpiration E_p , available water V_s and capillary rise R_r delivered to the root zone. The processes and calculations involved are also described in sect. 3.3. With the results obtained, the actual evapo-transpiration E_a (m^3 per m^2 total area) can be determined as:

$$E_a = E_{aA}A + E_{aB}B + E_{aU}U \quad (3.22)$$

3.3. Capillary rise and actual evapo-transpiration

The amount of capillary rise depends on the depth of the water table (D_w , m), the potential evapo-transpiration (E_p , m/day), the surface water resources (V_s , m/day) and the moisture deficit (M_d , m/day), representing the dryness of the topsoil. In Sahysmod, the depth D_w determines a capillary rise factor (F_c).

3.3.1. Depth of the water table and capillary rise factor

When the water table is below a critical depth (D_c , m), there is no potential capillary rise. When the water table is shallower than halfway the root zone ($\frac{1}{2}D_r$, m), the potential velocity of capillary rise is maximum as determined by the moisture deficit but not more than E_p . The influence of the depth of the water table between $\frac{1}{2}D_r$ and D_c is expressed in Sahysmod by a capillary rise factor (F_c) which ranges from 1, when $D_w < \frac{1}{2}D_r$, to 0, when $D_w > D_c$. In-between there is a linear relation. Hence:

$$F_c = 1 \quad [D_w < \frac{1}{2}D_r] \quad (3.23a)$$

$$F_c = 0 \quad [D_w > D_c] \quad (3.23b)$$

$$F_c = 1 - (D_w - \frac{1}{2}D_r) / (D_c - \frac{1}{2}D_r) \quad [\frac{1}{2}D_r < D_w < D_c] \quad (3.23c)$$

The above equations represent an approximation of the usually reported S-curves (e.g. Kabat and Beekma 1994) by 3 straight lines of which two are horizontal and one is sloping (fig. 3.4).

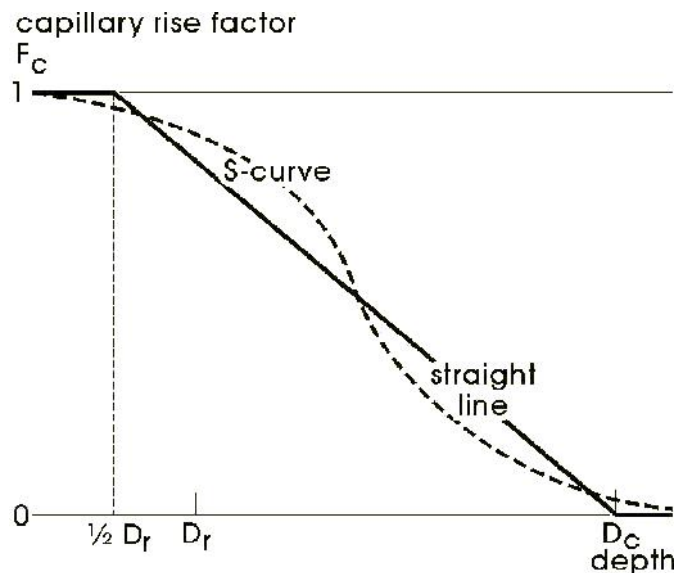

Figure 3.4 The S-curve of the capillary rise factor approximated by straight-line segments.

3.3.2. Potential evapo-transpiration and moisture deficit

The moisture deficit (M_d) is defined, with the condition that $M_d > 0$, as:

$$M_d = E_p - F_s V_s \quad (3.24)$$

where: E_p is the potential evapo-transpiration (m/day), F_s is the storage fraction (-) of the surface water resources, representing the moisture holding capacity, and V_s is the surface water resources.

When no capillary rise occurs, the product $F_s V_s$ represents the effective surface water resources, i.e. the part of the resources that is available for the evapo-transpiration, whereas the quantity $(1-F_s)V_s$ represents the part lost by percolation. When capillary rise does occur, Sahysmod adjusts the effective and lost quantities of the resources V_s .

When the term $E_p - F_s V_s$ is negative, the effective quantity of resources V_s is more than the evapo-transpiration E_p , and there is no moisture deficit. Then, M_d is taken equal to zero.

3.3.3. Apparent capillary rise and actual evapo-transpiration

In Sahysmod, the apparent quantity of capillary rise (R_a , m/day) is found from:

$$R_a = F_c M_d \quad (3.25)$$

i.e. the product of the capillary rise factor and the moisture deficit. When any of these two factors is zero, there is no capillary rise.

The actual evapo-transpiration (E_a , m/day) is found from:

$$E_a = F_s V_s + R_a \quad (3.26a)$$

With the above equations it is ensured that the evapo-transpiration E_a is never greater than the evapo-transpiration E_p .

The principles described for the calculation of the site-specific surface water resources V_s of the areas under group-A crops, group-B crops and the non-irrigated (U) land, can also be applied to the calculation of the site-specific values of E_a . We use for this the site-specific values F_{sA} , F_{sB} , F_{sU} given with the input and the site specific apparent capillary rise R_{aA} , R_{aB} , R_{aU} , derived from eqn. 3.25, as well as the site-specific moisture deficit M_{dA} , M_{dB} and M_{dU} , derived from eqn. 3.24, as follows:

$$E_{aA} = F_{sA} V_{sA} + R_{aA} \quad (3.26b)$$

$$E_{aB} = F_{sB} V_{sB} + R_{aB} \quad (3.26c)$$

$$E_{aU} = F_{sU} V_{sU} + R_{aU} \quad (3.26d)$$

3.3.4. Capillary rise

In Sahysmod, the amount of capillary rise (R_r) is defined as the contribution of the ground water to the evapo-transpiration. A part of the apparent evapo-transpiration R_a represents the return of percolation losses of the surface water resources from the transition zone into the root zone, whence it evaporates or transpires. This part can be considered as recovered after having been lost temporarily during the season. It does not represent a contribution from the ground water. Therefore the capillary rise proper is calculated as:

$$R_r = E_a - V_s \quad (3.27)$$

Hence, the part considered temporarily lost but recovered is:

$$I_c = R_a - R_r = (1-F_s)V_s \quad (3.28)$$

The principles described for the calculation of the site specific surface water resources V_s of the areas under group A crops, group B crops and the non-irrigated (U) land, can also be applied to the calculation of the site specific values of R_r :

$$R_{rA} = E_{aA} - V_{sA} \quad (3.29a)$$

$$R_{rB} = E_{aB} - V_{sB} \quad (3.29b)$$

$$R_{rU} = E_{aU} - V_{sU} \quad (3.29c)$$

3.4. The subsurface drainage

In Sahysmod the key K_d that can attain the values 0 or 1, indicates the presence of a subsurface drainage system $K_d = 0$ indicates that no subsurface drainage system is present and the subsurface drain discharge $G_d = 0$. When $K_d = 1$, a subsurface drainage system is present (fig. 3.5) and the drain discharge is calculated on the basis of Hooghoudt's drainage equation (Ritzema 1994):

$$G_t = \frac{8K_b D_e (D_d - D_w)}{Y_s^2} + \frac{4K_a (D_d - D_w)^2}{Y_s^2} \quad (3.30)$$

where: G_t is the total drain discharge (m/day), D_d is the drain depth (m), D_w is the depth of the water table (m), K_b is the hydraulic conductivity below drain level (m/day), D_e is the equivalent depth of the impermeable layer (m), K_a is the hydraulic conductivity above drain level (M), and Y_s is the drain spacing (m).

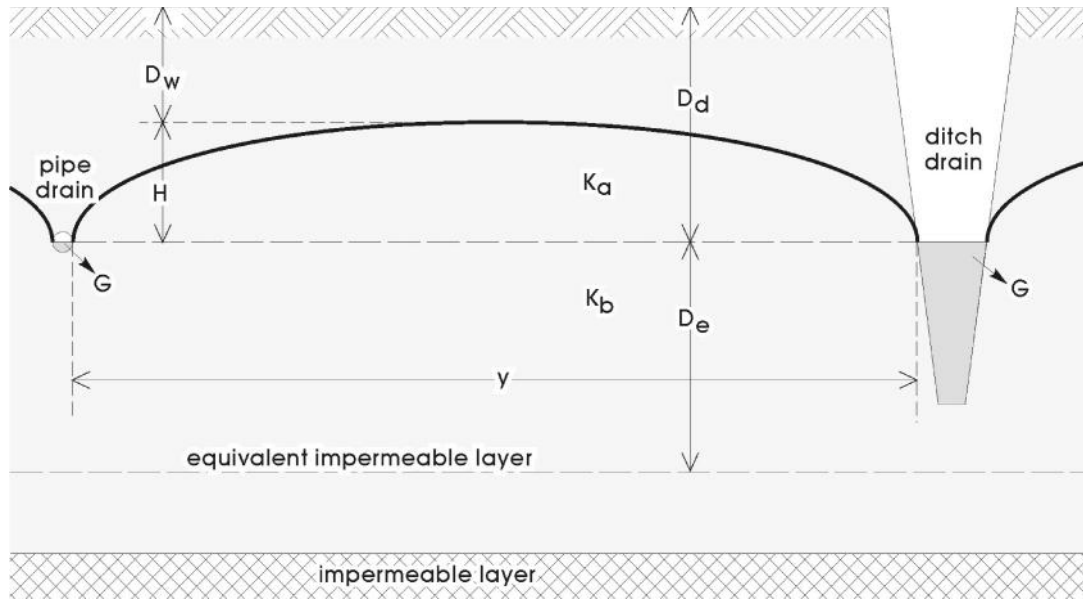

Figure 3.5 Factors in Hooghoudt's drainage equation equivalent depth of the impermeable layer (m), K_a is the hydraulic conductivity above drain level (m/day), and Y_s is the drain spacing (m).

The first term on the right hand side of eqn. 3.30 represents the discharge (G_z) from below the drain level and the second term the discharge (G_a) from above drain level.

Writing:

$$H_d = D_d - D_w \quad (3.31)$$

where H_d is the hydraulic head (m), one obtains from eqn. 3.30:

$$G_t = G_z + G_a \quad (3.32a)$$

where:

$$G_a = 4K_a H_d^2 / Y_s^2 \quad (3.32b)$$

$$G_z = 8K_b D_e H_d / Y_s^2 \quad (3.32c)$$

Here, the condition is imposed that $H > 0$. When $H < 0$, the values of G_a and G_z (m/day) are set equal to zero.

In Sahysmod, the drains are assumed to be situated in the transition zone so that the drain depth D_d must be in the range $D_r < D_d < D_r + D_x$, where D_r is the thickness of the root zone (m) and D_x is the thickness of the transition zone (m).

Defining:

$$G_a / H_d^2 = 4K_a / Y_s^2 = Q_{H2} \text{ (Ratio of } G_a \text{ to } H_d^2) \quad (3.33a)$$

$$G_z/H = 8K_b D_e / Y_s^2 = Q_{H1} \text{ (Ratio of } G_z \text{ to } H_d) \quad (3.33b)$$

it can be seen that the ratio's Q_{H1} and Q_{H2} represent the hydraulic conductivity and depth of the soil and the drain spacing. Now, one can write:

$$G_t = Q_{H1}H + Q_{H2}H^2 \quad (3.34)$$

Sahysmod provides the opportunity to introduce a checked drainage system through the introduction of a drainage control (drainage reduction) factor F_{cd} , having values between zero and 1. When the factor is 1, the drainage is fully checked and, when zero, it is totally unchecked. Thus, eqn. 3.34 changes into:

$$G_c = (1-F_{cd})(Q_{H1}H + Q_{H2}H^2) \quad (3.35a)$$

where G_c stands for the controlled drain discharge. Similarly the two discharge components change into:

$$G_{ca} = (1-F_{cd})G_a \quad (3.35b)$$

$$G_{cz} = (1-F_{cd})G_z \quad (3.35c)$$

To change the discharge from m/day to m/season, the following conversions are made:

$$G_d = \sum_1^{30T_s} G_c \quad (3.36a)$$

$$G_a = \sum_1^{30T_s} G_{ca} \quad (3.36b)$$

$$G_z = \sum_1^{30T_s} G_{cz} \quad (3.36c)$$

where T_s is the duration of the season (months).

3.5. Water balance of the transition zone

Eqn. 3.6 can be rewritten in two forms:

$$V_L = G_{qo} - G_{qi} + G_w + \Delta W_q \quad [V_R = 0, V_L > 0] \quad (3.36a)$$

$$V_R = G_{qi} - G_{qo} - G_w + \Delta W_q \quad [V_L = 0, V_R > 0] \quad (3.36b)$$

Further, Eqn. 3.5 can be rewritten as:

$$G_d = L_r + L_c + V_R - R_r - V_L - \Delta W_x \quad (3.37)$$

and the subsurface drainage G_d needs to meet this condition. However, the subsurface drainage is also found from eqn. 3.35c or 3.36, depending on the depth of the water table D_w . The reconciliation of the values is discussed in sect. 3.4.

3.6. Irrigation efficiencies and sufficiencies

The field irrigation efficiency F_f is defined as the ratio of the amount of irrigation water evaporated to the amount of irrigation water applied to the field. For the group A crop(s) we find:

$$F_{fA} = (E_{aA} - R_{rA}) / (I_{aA} + P_p) \quad (3.44a)$$

The irrigation efficiency of the group B crop(s) is similarly given by:

$$F_{fB} = (E_{aB} - R_{rB}) / (I_{aB} + P_p) \quad (3.44b)$$

The total irrigation efficiency, disregarding the bypass, is:

$$F_{ft} = [A(E_{aA} - R_{rA}) + B(E_{aB} - R_{rB})] / [I_t + P_p] \quad (3.45)$$

$$\text{where } I_t = I_f + L_c \quad (3.46)$$

The field irrigation sufficiency J_s is defined by ratio of the amount of actual over potential evapo-transpiration. For the group A crop(s) it is found from:

$$J_{sA} = E_{aA} / E_{pA} \quad (3.47a)$$

The field irrigation sufficiency of the group B crop(s) is similarly calculated as:

$$J_{sB} = E_{aB} / E_{pB} \quad (3.47b)$$

and the total field irrigation sufficiency as:

$$J_{et} = (J_{sA} + J_{sB}) / (A + B) \quad (3.47c)$$

Field irrigation can be:

1. Efficient and sufficient
2. Inefficient but sufficient
3. Efficient but insufficient
4. Inefficient and insufficient

The product of efficiency and sufficiency gives a measure of irrigation effectiveness J_e as follows.

Irrigation effectiveness in the land under group A crops:

$$J_{eA} = F_{aA} J_{sA} \quad (3.48a)$$

Irrigation effectiveness in the land under group B crops:

$$J_{eB} = F_{aB}J_{sB} \quad (3.48b)$$

Total irrigation effectiveness:

$$J_{et} = (F_{aA}J_{sA} + F_{aB}J_{sB}) / (A + B) \quad (3.48c)$$

The efficiencies, sufficiencies and effectiveness are a means to judge the impact of agricultural and water management practices on irrigation performance.

4 GROUND WATER FLOW

4.1 Finite difference method

A finite difference method is used to calculate the ground water flow. The method requires that total surface area is divided into unit areas (polygons) called nodal areas, since they each have a nodal point of which the parameters are considered representative for the whole polygon. Further, the method requires that a unit time step is taken. In Sahysmod this is one day. However, when the accuracy becomes insufficient, the time step is reduced to a fraction of one day.

In Sahysmod, the polygonal network is constructed on the basis of the given nodal coordinates using the Thiessen method. This method connects each nodal point with straight lines to the neighboring nodal points where-after perpendicular bisectrices are constructed on each of the connecting lines. The bisectrices are forming the polygons. The length of the connecting lines, the width of the sides of the polygon, and the surface-area of the polygon is calculated by elementary triangular mathematics.

For each of the nodes, identified by a node number, the user is required to indicate the identification numbers of the neighboring nodes.

It is essential that, before entering the data into the input file, a map of the study area is prepared in which the nodal points are precisely indicated. The density and distribution of the nodes must be done in conformity with the physical characteristics of the study area. These include topographic, soil, and geo-hydrologic conditions as well as agricultural, irrigation and drainage practices. Each nodal point should be representative for the conditions in its polygon.

In the following we choose arbitrarily a node b of the nodal network, which has number n_b of neighboring nodes j ($j = 1, 2, \dots, n_b$, (fig. 4.1), and an interval of 1 day.

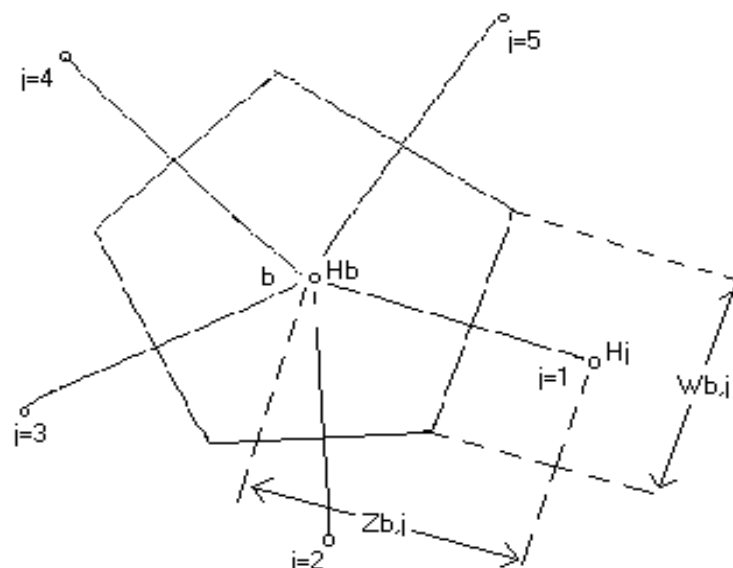

Figure 4.1 Geometry of the nodal network showing node b , neighboring nodes $j = 1$ to 5 and some relations between node b and node $j=1$.

4.2. Incoming and outgoing ground water flow

4.2.1 Flow between two unconfined aquifers

Unconfined aquifers are aquifers without soil layers hampering the horizontal flow (fig 4.2).

To determine the incoming (G_{bj} , m³/day) and outgoing (G_{jb} , m³/day) ground-water flow through the side of polygon b with polygon j we take into account that the flow is incoming when $H_{wj}-H_{wb}>0$, and outgoing when $H_{wj}-H_{wb}<0$. Thus we obtain:

Flow through the aquifer

The incoming (G_{bj} , m³/day) and outgoing (G_{jb} , m³/day) flow through one side of polygon b through the aquifer is:

$$G_{bj} = (H_{wj}-H_{wb}) \frac{W_{bj}K_{bj}D_{bj}}{Z_{bj}} \quad [H_{wj}-H_{wb}>0] \quad (4.1a)$$

$$G_{jb} = (H_{wb}-H_{wj}) \frac{W_{bj}K_{bj}D_{bj}}{Z_{bj}} \quad [H_{wb}-H_{wj}>0] \quad (4.1b)$$

where: H_{wb} is the height of the free water table in node b (m), H_{wj} is the height of the free water table in node j (m), K_{bj} is the representative hydraulic conductivity along the side between nodes b and j (m/day), W_{bj} is the length of the side between polygons b and j (m), Z_{bj} is the distance between nodes b and j (m), and D_{bj} is the average thickness of the aquifer between nodes b and j (m).

The thickness D_{bj} is found from:

$$D_{bj} = (D_{qb}+D_{qj})/2 \quad (4.2)$$

where:

$$D_{qb} = S_{Lb} - D_{rb} - D_{xb} - B_{Lb} \quad (4.3a)$$

$$D_{qj} = S_{Lj} - D_{rj} - D_{xj} - B_{Lj} \quad (4.3b)$$

where: D_{qb} is the thickness of the aquifer in node b (m), D_{qj} is the thickness of the aquifer in neighboring node j (m), S_{Lb} is the surface level of node b, S_{Lj} is the surface level of node j (m), D_{rb} is the thickness of the root zone in node b (m), D_{rj} is the thickness of the root zone in node j (m), D_{xb} is the thickness of the transition zone in node b (m), D_{xj} is the thickness of the transition zone in node j (m), B_{Lb} is the bottom level of the aquifer in polygon b (m) and B_{Lj} is the bottom level of polygon j (m).

Eqn. 4.2 holds the condition that $H_{wb}>B_{Lb}+D_{qb}$ and $H_{wj}>B_{Lj}+D_{qj}$. If these conditions are not met, then the thickness of the aquifer is replaced by the height of the water table above the bottom level of the aquifer:

$$D_{qb} = H_{wb} - B_{Lb} \quad (4.3c)$$

$$D_{qj} = H_{wj} - B_{Lj} \quad (4.3d)$$

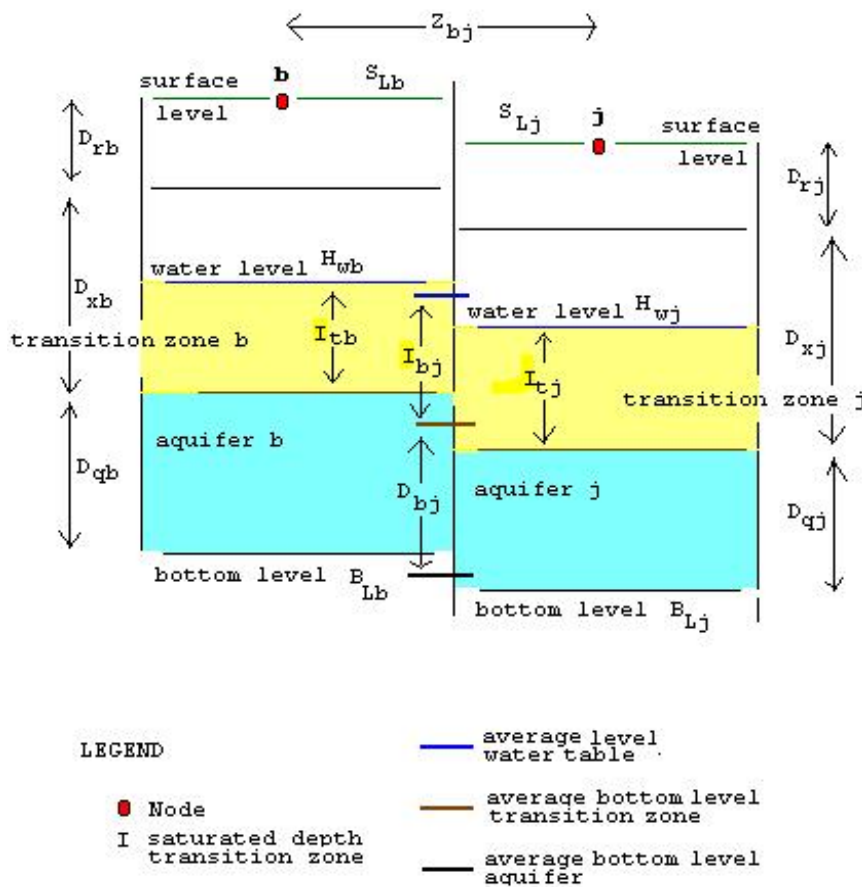

Figure 4.2 Geometry of unconfined (phreatic) flow between polygon b and neighboring polygon j. The symbol I used in the text for the saturated thickness of the transition zone is indicated by I instead

Flow through the transition zone

The incoming (χ_{bj} , m^3/day) and outgoing (χ_{jb} , m^3/day) flow through the transition zone is :

$$\chi_{bj} = (H_{wj} - H_{wb}) \frac{W_{bj} K_{bj} \theta_{bj}}{Z_{bj}} \quad [H_{wj} - H_{wb} > 0] \quad (4.4a)$$

$$\chi_{jb} = (H_{wb} - H_{wj}) \frac{W_{bj} K_{bj} \theta_{bj}}{Z_{bj}} \quad [H_{wb} - H_{wj} > 0] \quad (4.4b)$$

where: H_{wb} is the height of the free water table in node b (m), H_{wj} is the height of the free water table in node j (m), K_{bj} is the representative hydraulic conductivity along the side between nodes b and j (m/day), W_{bj} is the length of the side between polygons b and j (m), Z_{bj} is the distance between nodes b and j (m), and θ_{bj} is the average thickness of flow in the transition zone between nodes b and j (m).

The thickness θ_{bj} is found from:

$$\theta_{bj} = (\theta_{tb} + \theta_{tj})/2 \quad (4.5)$$

Here:

$$\theta_{tb} = H_{wb} - D_{qb} - B_{Lb} \quad (4.6a)$$

$$\theta_{tj} = H_{wj} - D_{qj} - B_{Lj} \quad (4.6b)$$

where: θ_{tb} is the saturated thickness of the transition zone in node b (m), θ_{tj} is the saturated thickness of the transition zone in neighboring node j (m).

Eqn. 4.5 holds the condition that $\theta_{bj} > 0$. If this condition is not met, then the flows χ_{bj} and χ_{jb} will be made zero.

4.2.2 Flow between two semi-confined aquifers

Semi-confined aquifers are aquifers covered by a relatively slowly permeable layer (fig 4.3). This covering layer starts at a depth D_t m below the soil surface and ends at a depth $D_x + D_r$ m so that its thickness is:

$$D_v = D_x + D_r - D_t \quad (4.7a)$$

and its transmissivity (m^2/day)

$$T_v = K_v D_v \quad (4.7b)$$

The transmissivities of the semi confining layer of polygon b and its neighbor j:

$$T_{vb} = K_{vb} D_{vb} \quad (4.7c)$$

$$T_{vj} = K_{vj} D_{vj} \quad (4.7d)$$

while their average value is:

$$T_{bj} = (K_{vb} D_{vb} + K_{vj} D_{vj})/2 \quad (4.7e)$$

The water level in the covering layer is represented by H_f (m) and the hydraulic head in the aquifer by H_q (m).

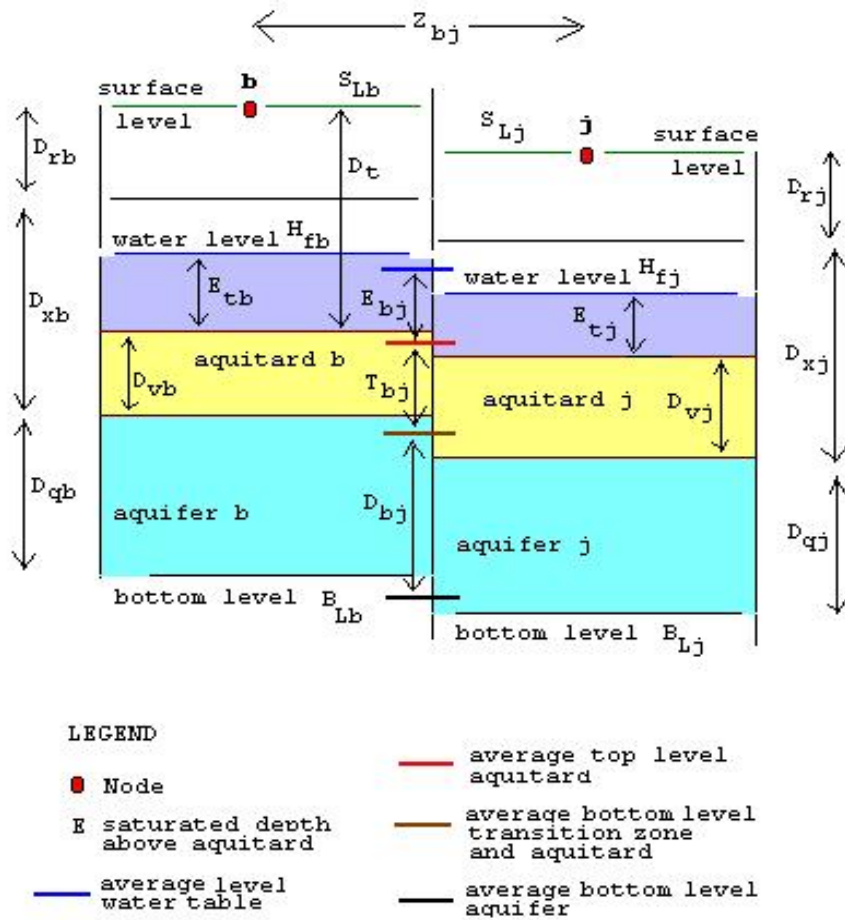

Figure 4.2 Geometry of semi-confined flow between polygon *b* and neighboring polygon *j*. The symbol E used in the text for the saturated thickness of the transition zone above the semi-confining layer is indicated by E instead

Flow through the aquifer

In similarity to Eqns. 4.1a and 4.1b, replacing H_{wb} and H_{wj} by H_{qb} and H_{qj} , the incoming (G_{bj} , m^3/day) and outgoing (G_{jb} , m^3/day) flow through the aquifer is:

$$G_{bj} = (H_{qj} - H_{qb}) \frac{W_{bj} K_{bj} D_{bj}}{Z_{bj}} \quad [H_{qj} - H_{qb} > 0] \quad (4.8a)$$

$$G_{jb} = (H_{qb} - H_{qj}) \frac{W_{bj} K_{bj} D_{bj}}{Z_{bj}} \quad [H_{qb} - H_{qj} > 0] \quad (4.8b)$$

All other equations and conditions are the same as mentioned for unconfined aquifers.

Flow through the transition zone

In similarity to eqns.4.4a and 4.4b, replacing, H_{wb} and H_{wj} by H_{fb} and H_{fj} , and adding T_v , the incoming flow (q_{bj} , m^3/day) and outgoing flow (q_{jb} , m^3/day) through the transition zone is:

$$\chi_{bj} = (H_{fj} - H_{fb}) \frac{W_{bj}(\Gamma_{bj}\eta_{bj} + T_{bj})}{Z_{bj}} \quad [H_{fj} - H_{fb} > 0] \quad (4.9a)$$

$$\chi_{jb} = (H_{fb} - H_{fj}) \frac{W_{bj}(\Gamma_{bj}\eta_{bj} + T_{jb})}{Z_{bj}} \quad [H_{fb} - H_{fj} > 0] \quad (4.9b)$$

where: H_{fb} is the height of the free water table in node b (m), H_{fj} is the height of the free water table in node j (m), Γ_{bj} is the representative hydraulic conductivity in the transition zone along the side between nodes b and j (m/day), W_{bj} is the length of the side between polygons b and j (m), Z_{bj} is the distance between nodes b and j (m), and η_{bj} is the average saturated thickness of flow in the transition zone between nodes b and j (m).

The thickness η_{bj} is found from:

$$\eta_{bj} = (\eta_{tb} + \eta_{tj})/2 \quad (4.10)$$

where:

$$\eta_{tb} = H_{fb} - D_{qb} - D_{vb} - B_{Lb} \quad [\eta_{tb} > 0] \quad (4.11a)$$

$$\eta_{tj} = H_{fj} - D_{qj} - D_{vj} - B_{Lj} \quad [\eta_{tj} > 0] \quad (4.11b)$$

Eqn. 4.10 holds the condition that $\eta_{bj} > 0$. If this condition is not met the flows χ_{bj} and χ_{jb} will be made zero.

4.2.3 Flow between unconfined and semi confined aquifers

When neighboring polygons are unconfined and semi confined, the thickness θ_{tb} , θ_{tj} , η_{tb} and η_{tj} are to be adjusted.

When the aquifer in polygon b is unconfined and in the neighbor is semi-confined:

$$\rho_1 = (\theta_{tb} + \eta_{tj})/2 \quad (4.11a)$$

and when the reverse relation is true:

$$\rho_2 = (\eta_{tb} + \theta_{tj})/2 \quad (4.11b)$$

When node b is unconfined and node j semi confined, the equivalent of eqns. 4.1a&b, 4.4a&b, 4.8a&b and 4.9a&b become:

$$G_{bj} = (H_{qj} - H_{wb}) \frac{W_{bj} D_{bj} K_{bj}}{Z_{bj}} \quad [H_{qj} - H_{wb} > 0] \quad (4.12a)$$

$$G_{jb} = (H_{wb} - H_{qj}) \frac{W_{bj} D_{bj} K_{bj}}{Z_{bj}} \quad [H_{wb} - H_{qj} > 0] \quad (4.12b)$$

$$\chi_{bj} = (H_{fj} - H_{wb}) \frac{W_{bj} (\Gamma_{bj} \rho_1 + \Theta_{bj})}{Z_{bj}} \quad [H_{fj} - H_{wb} > 0] \quad (4.13a)$$

$$\chi_{jb} = (H_{wb} - H_{fj}) \frac{W_{bj} (\Gamma_{bj} \rho_1 + \Theta_{jb})}{Z_{bj}} \quad [H_{wb} - H_{fj} > 0] \quad (4.13b)$$

where the average transmissivity of the layer between the aquifer and the top of the semi confining layer is:

$$\Theta_{bj} = (\Gamma_{bj} D_{vb} + T_{vj}) / 2$$

$$\Theta_{jb} = (\Gamma_{bj} D_{vj} + T_{vb}) / 2$$

When node b is semi confined and node j unconfined, the equivalent of eqns. 4.1a&b, 4.4a&b, 4.8a&b and 4.9a&b become:

$$G_{bj} = (H_{wj} - H_{qb}) \frac{W_{bj} D_{bj} K_{bj}}{Z_{bj}} \quad [H_{wj} - H_{qb} > 0] \quad (4.14a)$$

$$G_{jb} = (H_{qb} - H_{wj}) \frac{W_{bj} D_{bj} K_{bj}}{Z_{jb}} \quad [H_{qb} - H_{wj} > 0] \quad (4.14b)$$

$$\chi_{bj} = (H_{wj} - H_{fb}) \frac{W_{bj} (\Gamma_{bj} \rho_2 + \Theta_{bj})}{Z_{bj}} \quad [H_{wj} - H_{fb} > 0] \quad (4.15a)$$

$$\chi_{jb} = (H_{fb} - H_{wj}) \frac{W_{bj} (\Gamma_{bj} \rho_2 + \Theta_{jb})}{Z_{bj}} \quad [H_{fb} - H_{wj} > 0] \quad (4.15b)$$

4.2.4 Inflow and outflow per polygon

Setting the number of sides with inflow at l_b and with outflow at m_b ($l_b + m_b = n_b$, where n_b is the total number of sides of polygon b), we find the total inflow (G_i , m^3/day) and outflow (G_o , m^3/day) of polygon b through the aquifer from:

$$G_i = \sum_{j=1}^{l_b} G_{bj} \quad (4.16a)$$

$$G_o = \sum_{j=1}^{m_b} G_{jb} \quad (4.16b)$$

The total inflow (χ_i , m³/day) and outflow (χ_o , m³/day) of polygon b through the aquifer is found from:

$$\chi_i = \sum_{j=1}^{l_b} \chi_{bj} \quad (4.17a)$$

$$\chi_o = \sum_{j=1}^{m_b} \chi_{jb} \quad (4.17b)$$

4.2.5 Vertical flow in semi-confined aquifers

In the slowly permeable top layer of a semi confined aquifer there will be a vertical flow when the water level H_f in the top layer is different from the hydraulic head H_q in the aquifer. The vertical flow V_v is found from:

$$V_v = K_v(H_f - H_q)/D_v \quad (4.18)$$

where K_v is the vertical hydraulic conductivity in the top layer (m/day).

When the water table is inside the aquifer (H_f does not exist), the vertical flow V_v is made equal to zero.

4.3 Inflow of salt

The inflow of salt through transition zone ζ_{ti} and aquifer ζ_{tq} into polygon b is calculated by:

$$\zeta_{xi} = \sum_{j=1}^{l_b} \chi_{bj} F_{lxj} C_{qj} \quad (4.19a)$$

$$\zeta_{tq} = \sum_{j=1}^{l_b} G_{bj} F_{lqj} C_{xj} \quad (4.19b)$$

where F_{lxj} is the leaching efficiency of the transition zone in polygon j (fraction), C_{xj} is the salt concentration of the water in the transition zone of polygon j (dS/m), F_{lqj} is the leaching efficiency of the aquifer in polygon j (fraction), C_{qj} is the salt concentration of the water in the aquifer of polygon j (dS/m).

As explained in sect. 5.2.3, the value of C_{xj} equals C_{xi} when a subsurface drainage system is absent and C_{xbi} when a subsurface drainage system is present.

4.4 Change of ground water level

The change of the ground water level in unconfined aquifers is found from:

$$H_{wf} = H_{wi} + (V_i + G_i + \chi_i - V_o - G_o - \chi_o)/P_{ei} \quad (4.20)$$

where: H_{wf} is the value of H_{wb} at the end of the time step (m), H_{wi} is the value of H_{wb} at the start of the time step (m), V_i is the vertically downward recharge calculated by one of the agricultural water balances in sect. 3 (m/day), V_o is the vertically upward discharge calculated by one of the agricultural water balances in sect. 3 (m/day) and P_{ei} is the effective porosity or drainable pore space.

The recharge V_i and discharge V_o and the porosity P_{ei} depend on whether the water table is above the soil surface, in the root zone, in the transition zone or in the aquifer (m/m).

For the top layer of semi confined aquifers, eqn. 4.21 is changed into:

$$H_{ff} = H_{fi} + (V_v + V_i + \chi_i - V_o - \chi_o)/P_{ei} \quad (4.21)$$

where: H_{ff} is the value of H_f at the end of the time step (m), H_{fi} is the value of H_f at the start of the time step (m)

For aquifers overlain by a slowly permeable top layer, eqn. 4.7 is changed into:

$$H_{qf} = H_{qi} + (V_v + G_{bi} + \chi_i - G_{bo} - \chi_o)/P_{sq} \quad (4.22)$$

where: H_{qf} is the value of H_q at the end of the time step (m), H_{qi} is the value of H_q at the start of the time step (m), and P_{sq} is the storativity or specific yield of the highly permeable subsoil (m/m).

4.5 Seasonal values

The seasonally incoming and outgoing horizontal ground-water flows (G_{si} and G_{so} , m^3 /season per m^2 surface area or m/season) through the aquifer are found from:

$$G_{si} = \sum_{i=1}^{30T_s} G_i/A_b \quad (4.23a)$$

$$G_{so} = \sum_{i=1}^{30T_s} G_o/A_b \quad (4.23b)$$

The seasonally incoming and outgoing horizontal ground-water flows (χ_{si} and χ_{so} , m^3 /season per m^2 surface area or m/season) through the transition zone aquifer are found from:

$$\chi_{si} = \frac{30T_s}{\sum_{i=1} \chi_i/A_b} \quad (4.24a)$$

$$\chi_{so} = \frac{30T_s}{\sum_{i=1} \chi_o/A_b} \quad (4.24b)$$

The seasonal average depth of the water table:

$$D_{wa} = S_L - \frac{30T_s}{\sum_{i=1} H_{wb}/30T_s} \quad (4.25)$$

The seasonal average quantity of incoming salt through the transition zone is:

$$\zeta_{st} = \frac{30T_s}{\sum_{i=1} \zeta_{ti}/A_b} \quad (4.26a)$$

and through the aquifer:

$$\zeta_{sq} = \frac{30T_s}{\sum_{i=1} \zeta_{qi}/A_b} \quad (4.26b)$$

The seasonal average salt concentration of the salt inflows through transition zone and aquifer are found from respectively:

$$C_{ti} = \zeta_{st} / \chi_{si} \quad (4.27a)$$

$$C_{ai} = \zeta_{sq} / G_{si} \quad (4.27b)$$

When the program has introduced shorter time steps than 1 day, the above equation is adjusted automatically.

4.6 Possibilities of and conditions for application

The following application conditions are incorporated in the ground water flow part of the model:

- The main aquifer is bounded at the bottom by an impermeable layer, but an inflow condition, e.g. through faults, can be imposed;
- The upper boundary of the aquifer is the free water table (phreatic or unconfined aquifer) or a relatively slowly permeable layer with respect to the underlying layer (the semi-confining layer forming the semi-confined aquifer);
- Darcy's law and Dupuit's assumptions (resistance to vertical flow in the subsoil can be neglected) are applicable in the main aquifer. However, when the resistance to vertical flow is not negligibly small (e.g. as in radial flow to or from a river or canal), one may introduce an imaginary equivalent depth of the impermeable layer, which is smaller than the actual depth, as in Hooghoudt's drainage equation. Also imaginary equivalent hydraulic conductivities may be used;

- In semi-confined aquifers the resistance to vertical flow in the top layer is taken into account, but the horizontal flow is excluded;
- The aquifer has head-controlled or flow-controlled boundaries, which may vary from, season to season;
- For unconfined aquifers the transmissivity varies with time; the model adjusts the saturated thickness according to the calculated water table elevation; the same applies to the vertical flow in the slightly permeable top layer of a semi-confined aquifer and to the horizontal flow above the semi confining layer.
- To create boundaries of flow symmetry it is possible to assign zero hydraulic conductivity to some of the sides of the polygons so that no flow passes through them.
- To simulate the flow in a ground water system with 3 layers of which the depths and hydraulic conductivity are known one may set the aquifer at semi confined even when the middle layer does not have a very small conductivity.

The ILRI Publ. 29 (Boonstra and de Ridder,1981) is referred to for more details on the part of the model dealing with the ground water flow and construction of polygons

5. SALT BALANCES

5.1. Change in salt content

The salt balances are, like eqn. 3.1, based on the equation:

$$\text{incoming salt} = \text{outgoing salt} + \text{storage of salt}$$

In addition we have:

- incoming salt = inflow x salt concentration of the inflow
- outgoing salt = outflow x salt concentration of the outflow
- salt concentration of the outflow = leaching efficiency x salt concentration of the water in the reservoir of outflow
- change in salt concentration of the soil = salt storage divided by amount of water in the soil

Hence, the salt balances are based on the water balances. In Sahysmod, the salt balances are calculated separately for the different reservoirs and, in addition, for different types of cropping rotation, indicated by the key K_r , which can attain the values 0, 1, 2, 3, and 4. $K_r = 0$ indicates that there is no annual cropping rotation and all land use types are fixed to the same areas each year. $K_r = 4$ indicates that there is full annual cropping rotation and that the land use types are continually moved over the area. The other values of K_r indicate intermediate situations explained elsewhere.

In the following, all salt concentrations are expressed as electric conductivity (EC) in dS/m. Salt concentrations of soil moisture are given on the basis of saturated soil as the concentrations depend on the soil moisture content.

The concentration at field saturation deviates from that of the saturated paste (EC_e), which is less because the dilution is more. The ratio between the two values is about 2.

Quantities of salt, being the product of an amount of water in m/day and a concentration in dS/m, are expressed in dS/day.

The user is free to enter other units of salinity (e.g. g/l), but in that case the simulation of farmers' responses to soil salinization is no longer valid.

The salinity of the various soil strata is calculated day by day, but in the output file Sahysmod only provides the accumulated values at the end of each season.

5.2. Salt balances under full cropping rotation

In the salt balances under full cropping rotation ($K_r=4$), all hydrological and salinity values of the different land use types are pooled (fig. 5.1)

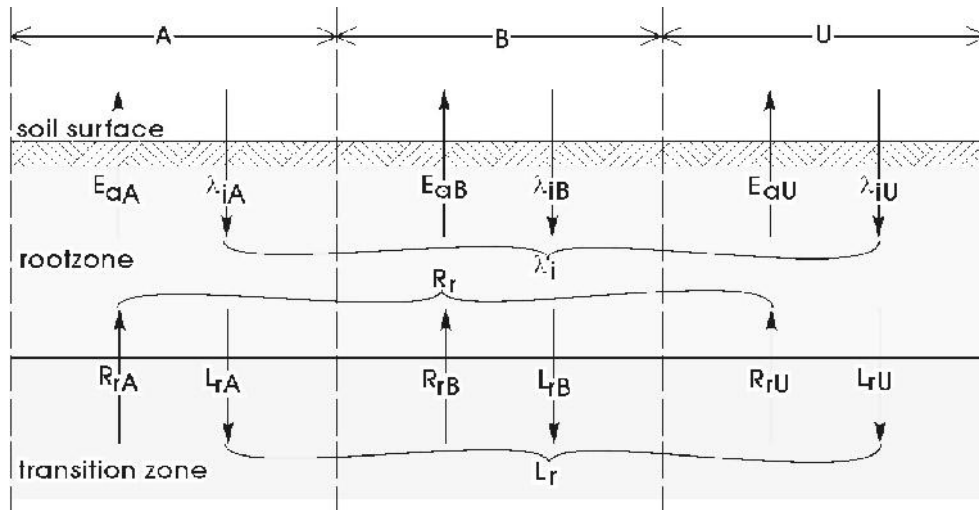

Figure 5.1. Pooled hydrological factors in areas under full cropping rotation ($K_r = 4$)

5.2.1. Above the soil surface

The salt balance above the soil surface is calculated only when the water table is above the soil surface using the overall water balance (eqn. 3.15). The in-filtration is calculated from:

$$\lambda_i = G_o + G_w + G_d + G_i \quad [\lambda_i > 0] \quad (5.1a)$$

and the ex-filtration λ_o from:

$$\lambda_o = G_i - G_w - G_d - G_o \quad [\lambda_o > 0] \quad (5.1b)$$

The amount of salt brought into the surface reservoir by irrigation, rainfall and upward flow of ground water (ex-filtration) is:

$$Z_{se} = C_i(I_{aA}A + I_{aB}B + S_{iU}U) + C_pP_p + C_{r4i}\lambda_o \quad (5.2a)$$

where C_i is the salt concentration of the irrigation water including the re-use of drain and well water (eqn. 60, dS/m), and C_{r4i} is the salt concentration of the soil moisture in the root zone at the start of the time step when saturated, equal to the salt concentration of the same at the end of the previous time step (dS/m)

The amount of salt flowing out by surface drainage is:

$$Z_{so} = C_{si}(I_o + S_{oA}A + S_{oB}B + S_{oU}U + \lambda_i) \quad (5.2b)$$

where C_{si} is the initial salt concentration of the water above the soil surface, i.e. at the start of the time step.

The final amount of salt stored above the soil surface, i.e. at the end of the time step, now becomes:

$$Z_{sf} = Z_{si} + Z_{se} + Z_{so} \quad (5.3c)$$

where Z_{si} is the initial salt storage above the soil surface, i.e. at the start of the time step.

The amounts of salt Z_s are expressed in m water height x EC in dS/m, i.e. m.dS/m, which can be interpreted as the salinity of the water if it stands 1 m above the soil surface. When the water height is more, the salinity is proportionally less and vice versa.

The concentration C_p can usually be taken equal to zero, but in coastal areas it may reach a positive value

5.2.2. Root zone

The salt balance of the root zone depends on three situations:

- 1 - the water table is below the soil surface in the present and the previous time step, or it is above the soil surface while it was below in the previous time step
- 2 - the water table is above the soil surface in the present and previous time step
- 3 - the water table is below the soil surface in the season while it was previously above it

Water table situation 1

The salt balance of the root zone is made on the basis of the topsoil water balance (eqn. 3.7):

$$\Delta Z_{r4} = P_p C_p + (I_g - I_o) C_i - S_o(0.2C_{r4i} + C_i) + R_{rT} C_{xki} - L_{rT} C_{L4} \quad (5.4a)$$

where: ΔZ_{r4} is salt storage in the root zone when $K_r=4$ (dS/season), C_p is the salt concentration of the rain water (dS/m), C_i is the salt concentration of the surface irrigation water including the use of drain or well water for irrigation (dS/m), C_{xki} is the salt concentration of the capillary rise based on soil salinity in the transition zone, when saturated, at the end of the previous time step and depending on the presence or absence of a subsurface drainage system as defined in eqn. 5.5a,b (dS/m), and C_{L4} (eqn. 5.8) is the salt concentration of the percolation water at the end of the previous time step (dS/m).

Water table situation 2

Eqn. 5.3a changes into:

$$\Delta Z_{r4} = \lambda_i(C_{st} - C_{L4}) - \lambda_o(C_{L4} - C_{xki}) \quad (5.4b)$$

Water table situation 3

The amount of salt stored above the soil surface is added to the root zone and eqn. 5.3a changes into:

$$\Delta Z_{r4} = \lambda_i(C_{st} - C_{L4}) - \lambda_o(C_{L4} - C_{xki}) + Z_{si} \quad (5.4c)$$

Subsequently the value of Z_{sf} is made equal to zero.

The initial salt concentration of the transition zone depends on the presence of a subsurface drainage system. If present then:

$$C_{xki} = C_{xai} \quad (5.5a)$$

otherwise:

$$C_{xki} = C_{xi} \quad (5.5b)$$

where: C_{xi} is the salt concentration of the water in the transition zone, when saturated, at the end of the previous time step (EC in dS/m), C_{xai} is the salt concentration of the water in the part of the transition zone which is above drain level, when saturated (EC in dS/m).

5.2.2.1 Salt concentration of the irrigation water

The salt concentration C_i of the irrigation water depends on the use of ground water for irrigation:

$$C_i = (I_i C_{ic} + D_d C_{di} + F_w G_w C_{qi}) / (I_i + D_d + F_w G_w) \quad (5.6)$$

where: C_{ic} is the known salt concentration of the in-flowing canal water at the end of the previous time step (dS/m), C_{di} is the salt concentration of the drainage water at the end of the previous time step (dS/m), C_{qi} is the salt concentration of the water in the aquifer, when saturated, at the end of the previous time step (dS/m).

5.2.2.2 Initial salt concentration of the drainage water

The calculation of the salt concentration C_{di} is based on eqn. 31 and found from:

$$C_{di} = F_{lx} (G_{db} C_{xbi} + G_{da} C_{xai}) / G_d \quad (5.7)$$

where: F_{lx} is the leaching efficiency of the transition zone (-), C_{xbi} is the salt concentration of the soil moisture in the part of the transition zone below drain level, when saturated, at the end of the previous time step (dS/m), C_{xai} is the salt concentration of the soil moisture in the part of the transition zone above drain level, when saturated, at the end of the previous time step (dS/m).

5.2.2.3 Salt concentration of the percolation water

The salt concentration C_{L4} of the percolation water at the end of the previous time step is found from:

$$C_{L4} = F_{lr} C_{r4v} \quad (5.8)$$

where: C_{r4v} is the salt concentration of the soil moisture in the root zone when saturated at the end of the previous time step (dS/m), and F_{lr} is the leaching efficiency of the root zone

5.2.2.4 Final salt concentration in the root zone

The final salt concentration of the soil moisture in the root zone, when saturated, is calculated as:

$$C_{r4f} = C_{r4i} + \Delta Z_{r4} / P_{tr} D_r \quad (5.9)$$

5.2.3. Transition zone

The salt balance of the transition zone depends on the absence or presence of a subsurface drainage system.

5.2.3.1 Absence of a subsurface drainage system

In the absence of a subsurface drainage system, the salt balance of the transition zone is based on the water balance of the same (eqn. 3.5):

$$L_{rT} C_{L4} + L_c C_{ic} + V_R C_{qi} + \zeta_{ti} = R_{rT} C_x + F_{lx} C_x (V_L + G_{to}) + \Delta Z_x \quad (5.10)$$

where: C_q is the salt concentration of the water in the aquifer, when saturated (EC in dS/m), ζ_{ti} is inflow of salt with the horizontally incoming ground water into the transition zone (eqn. 4.19a), C_x is the salt concentration of the water in the transition zone, when saturated, at the end of the previous time step (EC in dS/m) and ΔZ_x is the storage of salt in the transition zone.

When the water table is above the soil surface we replace $L_{rT} = \lambda_i$ and $R_{rT} = \lambda_o$ in the above equations.

5.2.3.2 Presence of a subsurface drainage system

When a subsurface drainage system is present, the steady state water balance of the transition zone (eqn. 3.5) is split into a balance of the upper part, above drain level, and a lower part, below drain level. For the upper part we have:

$$L_{rT} + L_c + V_R - V_L - G_u = R_{rT} + G_a \quad (5.11a)$$

and for the lower part:

$$L_{rT} + L_c - R_{rT} - G_a + V_R = V_L + G_u \quad (5.11b)$$

As in the root zone, we have $L_{rT} = \lambda_i$ and $R_{rT} = \lambda_o$ when the water table is above the soil surface.

Hence, the salt balance of the upper part becomes:

$$\Delta Z_{xa} = L_{rT} C_{L4} + L_c C_{ic} + (V_R - V_L - G_u) F_{lx} C_{xbi} - R_{rT} C_{xa} - F_{lx} G_a C_{xa} \quad (5.12)$$

where: ΔZ_{xa} is the salt storage in the part of the transition zone above drain level (dS/season), C_{xa} is the salt concentration of the water in the part of the transition zone, when saturated,

above the drain level at the end of the previous time step (EC in dS/m), and $C_{x_{bi}}$ is the salt concentration of the water in the part of the transition zone below drain level, when saturated, at the end of the previous time step (EC in dS/m).

The salt balance of the lower part becomes:

$$\Delta Z_{xb} = F_{lx}(L_{rT} + L_c - R_{rT} - G_a)C_{xa} + V_R C_{qi} - F_{lx}(V_L + G_u)C_{xb} \quad (5.13)$$

where: ΔZ_{xb} is the salt storage in the part of the transition zone above drain level (dS/season), C_{xb} is the salt concentration of the water in the part of the transition zone, below the drain level at the end of the previous time step (EC in dS/m).

5.2.3.3 Final salt concentration in the transition zone

In the absence of a subsurface drainage system, the final salt concentration of the soil moisture in the transition zone, when saturated, is calculated as:

$$C_{xf} = C_{xi} + \Delta Z_x / P_{tx} D_x \quad (5.14)$$

In the presence a subsurface drainage system, the final salt concentration of the soil moisture in the upper part of the transition zone, when saturated, above drain level, is calculated as:

$$C_{xaf} = C_{xai} + \Delta Z_{xa} / \{P_{tx}(D_d - D_r)\} \quad (5.15a)$$

In the presence a subsurface drainage system, the final salt concentration of the soil moisture in the lower part of the transition zone, when saturated, below drain level, is calculated as:

$$C_{xbf} = C_{x_{bi}} + \Delta Z_{xb} / \{P_{tx}(D_r + D_x - D_d)\} \quad (5.15b)$$

5.2.4. Aquifer

The salt balance of the aquifer zone is based on the water balance of the same (eqn. 3.6):

$$\Delta Z_q = \zeta_{qi} + V_L C_{xx} - (G_{qo} + V_R + G_w) C_{ov} \quad (5.16)$$

where: ζ_{qi} is the inflow of salt with the horizontally in-flowing ground water (eqn. 4.19b), C_{ov} is the salt concentration of the horizontally out-flowing ground water (dS/m), and C_{xx} is the salt concentration of the water in the transition zone at the end of the previous time step depending on the absence or presence of a subsurface drainage system (dS/m):

$$C_{xx} = C_{xa} \quad [K_d = 0] \quad (5.17a)$$

$$C_{xx} = C_{xb} \quad [K_d = 1] \quad (5.17b)$$

The final salt concentration of the soil moisture in the aquifer, when saturated, is calculated as:

$$C_{qf} = C_{qi} + \Delta Z_q / P_{tq} D_q \quad (5.18)$$

5.2.5. Salt concentration of drain and well water

The salt concentration C_d (EC in dS/m) of the subsurface drainage water at the end of the previous time step is calculated on the basis of eqn. 31 as a weighed average of the salt concentrations of the flows entering the drain from above and below drain level at the end of the previous time step:

$$C_d = F_{lx}(G_a C_{xa} + G_{xb}) / G_d \quad (5.19)$$

The salt concentration C_w of the pumped well water at the end of the previous time step is found from:

$$C_w = F_{lx} C_{qv} \quad (5.20)$$

5.3. Salt balances under zero cropping rotation

In the salt balances under zero cropping rotation ($K_r=0$), all hydrological and salinity values for the root zones of the different land use types are separated, but in the transition zone they are pooled (fig. 5.2).

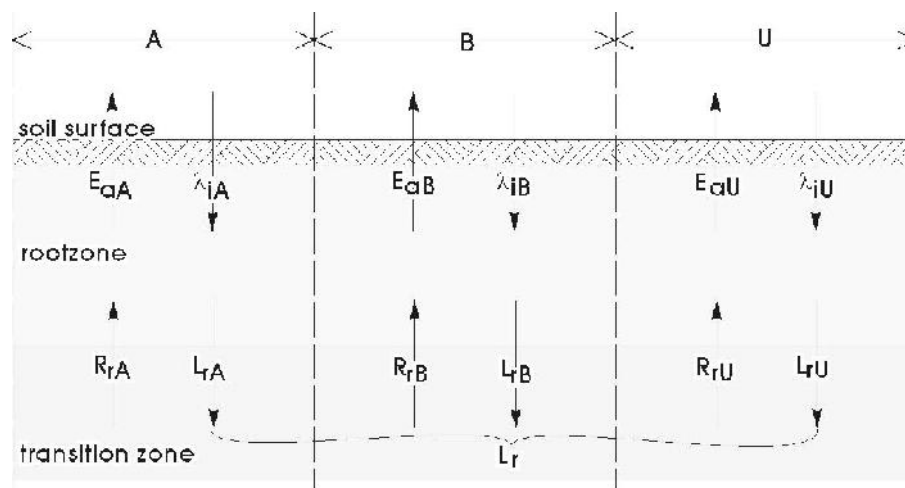

Figure 5.2 Separated hydrological factors in the root zone under zero cropping rotation ($K_r = 0$), pooling of factors in the transition zone

5.3.1. Above the soil surface

The principles of the salt balance described in sect. 5.2.1 apply equally here.

The amount of salt entering the water body above the soil surface is calculated slightly differently as:

$$Z_{se} = C_i(I_{aA}A + I_{aB} + S_{iU}) + C_p P_p + (C_{r0Ai} + C_{r0Bi} + C_{r0Ui})\lambda_o \quad (5.21)$$

where: C_{r0Ai} is the salt concentration of the soil moisture in the root zone, when saturated, of the group A crop(s), at the start of the time step, equal to the salt concentration of the same at the end of the previous time step (dS/m), C_{r0Bi} is the salt concentration of the soil moisture in the root zone, when saturated, of the group B crop(s), at the start of the time step, equal to the salt concentration of the same at the end of the previous time step (dS/m), C_{r0Ui} is the salt concentration of the soil moisture in the root zone, when saturated, of the non-irrigated land at the start of the time step, equal to the salt concentration of the same at the end of the previous time step (dS/m).

The calculations of Z_{so} , and Z_{sf} remain unchanged.

5.3.2. Root zone

The water table situations are as described in sect. 5.2.1.

Water table situation 1

The salt balance of the root zone (eqn. 3.4) is split into 3 parts:

$$\Delta Z_{r0A} = P_p C_p + I_{aA} C_i + R_{rA} C_{xki} - S_{oA} (0.2 C_{r0Ai} + C_i) - L_{rA} C_{L0A} \quad (5.22a)$$

$$\Delta Z_{r0B} = P_p C_p + I_{aB} C_i + R_{rB} C_{xki} - S_{oB} (0.2 C_{r0Bi} + C_i) - L_{rB} C_{L0B} \quad (5.22b)$$

$$\Delta Z_{r0U} = P_p C_p + S_{iU} C_i + R_{rU} C_{xki} - S_{oU} (0.2 C_{r0Ui} + C_i) - L_{rU} C_{L0U} \quad (5.22c)$$

where: ΔZ_{r0A} is the salt storage in the root zone of the irrigated group A crop(s) when $K_r=0$ (dS/season), ΔZ_{r0B} is the salt storage in the root zone of the irrigated group B crop(s) when $K_r=0$ (dS per season), ΔZ_{r0U} is the salt storage in the root zone of the non-irrigated land when $K_r=0$ (dS/season), C_{L0A} is the salt concentration of the percolation water from the irrigated group A crop(s) at the end of the previous time step (dS/m), C_{L0B} is the salt concentration of the percolation water from the irrigated group B crop(s) at the end of the previous time step (dS/m), and C_{L0U} is the salt concentration of the percolation water from the non-irrigated land at the end of the previous time step (dS/m).

Water table situation 2

Eqns. 5.22a,b,c are changed into:

$$\Delta Z_{r0A} = \lambda_i (C_{si} - C_{L0A}) - \lambda_o (C_{L0A} - C_{xki}) \quad (5.22d)$$

$$\Delta Z_{r0B} = \lambda_i (C_{si} - C_{L0B}) - \lambda_o (C_{L0B} - C_{xki}) \quad (5.22e)$$

$$\Delta Z_{r0U} = \lambda_i (C_{si} - C_{L0U}) - \lambda_o (C_{L0U} - C_{xki}) \quad (5.22f)$$

Water table situation 3

Eqns. 5.22a,b,c are used with the value of Z_{si} added to each like in eqn. 5.4c. Subsequently the value of Z_{si} is made equal to zero.

The salt concentrations C_{L0A} , C_{L0B} , and C_{L0U} of the percolation water at the end of the previous time step in the above equations are found from:

$$C_{L0A} = F_{ir}C_{r0A} \quad (5.23a)$$

$$C_{L0B} = F_{ir}C_{r0B} \quad (5.23b)$$

$$C_{L0U} = F_{ir}C_{r0U} \quad (5.23c)$$

where: C_{r0A} is the salt concentration of the soil moisture in the root zone, when saturated, of the group A crop(s) when $K_r=0$ at the end of the previous time step (dS/m), C_{r0B} is the salt concentration of the soil moisture in the root zone, when saturated, of the group B crop(s) when $K_r=0$ at the end of the previous time step (dS/m), and C_{r0U} is the salt concentration of the soil moisture in the root zone, when saturated, of the non-irrigated land when $K_r=0$ at the end of the previous time step (dS/m). The final salt concentrations of the soil moisture in the root zone are calculated as:

$$C_{r0Af} = C_{r0Ai} + \Delta Z_{r0A}/P_{tr}D_r \quad (5.24a)$$

$$C_{r0Bf} = C_{r0Bi} + \Delta Z_{r0B}/P_{tr}D_r \quad (5.24b)$$

$$C_{r0Uf} = C_{r0Ui} + \Delta Z_{r0U}/P_{tr}D_r \quad (5.24c)$$

5.3.3. Transition zone

The salt concentration C_{L0} of the percolation water into the transition zone is calculated as the weighed average of the salt concentrations of the percolation water from the A, B, and U areas:

$$C_{L0} = (L_{rA}C_{r0A}A + L_{rB}C_{r0B}B + L_{rU}C_{r0U}U)/(L_{rA}A + L_{rB}B + L_{rU}U) \quad (5.25)$$

The other salt balances of the transition zone are calculated with the equations of section 5.2.3.3, C_{L0} replacing C_{L4} .

When the water table is above the soil surface we find that $L_{rA}=L_{rB}=L_{rU}=\lambda_i$ and $R_{rA}=R_{rB}=R_{rU}=\lambda_o$.

5.4. Salt balances under intermediate cropping rotations

5.4.1. Types of cropping rotation

Sahysmod offers the following three intermediate cropping rotation types:

1. A part or all of the non-irrigated land is permanently used unchanged such throughout the seasons (e.g. permanently uncultivated land, non-irrigated grazing land, non-irrigated (agro-forestry, abandoned land). The rotation key K_r is set equal to 1.
2. A part or all of the land under group A crop(s) is permanently used unchanged such throughout the seasons (e.g. the land under irrigated sugar cane, double irrigated rice cropping). The rotation key K_r is set equal to 2.
3. A part or all of the land under group B crop(s) is permanently used unchanged such throughout the seasons (e.g. the land under irrigated orchards). The rotation key K_r is set equal to 3.

It is immaterial whether one assigns a permanent land use type either to the A or B group of crop(s). Also, a group of crops may consist of only one type of crop. It would be good practice to reserve one group for the intensively irrigated crops and the other for the more lightly irrigated crops.

The Sahysmod program calculates the minimum seasonal area fraction of the land use fractions A, B and U. These minima are called A_c , B_c and U_c respectively. Depending on the value of K_r , we have the following situations:

1. $K_r = 1$. The fraction U_c is used as the permanently non-irrigated land, throughout the seasons, and the fraction $1-U_c$ is the land with fully rotational land use of irrigated A and/or B type crops and/or non-irrigated land
2. $K_r = 2$. The fraction A_c is used as the permanently irrigated land under group A crop(s), throughout the seasons, and the fraction $1-A_c$ is the land with fully rotational land use of irrigated A and/or B type crops and/or non-irrigated land
3. $K_r = 3$. The fraction B_c is used as the permanently irrigated land under group B crop(s), throughout the seasons, and the fraction $1-B_c$ is the land with fully rotational land use of irrigated A and/or B type crops and/or non-irrigated land

5.4.2. Part of the area permanently non-irrigated, $K_r=1$

5.4.2.1 Above soil surface

The principles of the salt balance described in sect. 5.2.1 apply equally here.

The amount of salt entering the water body above the soil surface is calculated slightly differently as:

$$Z_{se} = C_i(I_{aA}A + I_{aB}B + S_{iU}U) + C_pP_p + (C_{r1U_i} + C_{r1*i_i})\lambda_o \quad (5.26)$$

where: C_{r1U_i} is the salt concentration of the soil moisture in the root zone, when saturated, in the permanently non-irrigated land, at the start of the time step, equal to the salt concentration of the same at the end of the previous time step (dS/m), C_{r1*i_i} is the salt concentration of the soil moisture in the root zone, when saturated, of the land outside the permanently non-irrigated area, at the start of the time step, equal to the salt concentration of the same at the end of the previous time step (dS/m).

The calculations of Z_{so} , and Z_{sf} remain unchanged.

5.4.2.2 Root zone

Water table situation 1

The salt balance of the root zone (eqn. 5.4a) is split into 2 parts, one separate part for the permanently non-irrigated area U_c and one pooled part for the remaining area $1-U_c=U^*$ with full cropping rotation (fig. 5.3). The balance reads:

$$\Delta Z_{r1U} = P_p C_p + S_{iU} C_i + R_{rU} C_{xki} - S_{oU} (0.2 C_{r1U_i} + C_i) - L_{rU} C_{L1U} \quad (5.27a)$$

$$\begin{aligned} \Delta Z_{r1*} = & P_p C_p + (\Omega_{1A} I_{aA} + \Omega_{1B} I_{aB} + \Omega_{1U} S_{iU}) C_i + (\Omega_{1A} R_{rA} + \Omega_{1B} R_{rB} + \Omega_{1U} R_{rU}) C_{xki} \\ & - (\Omega_{1A} S_{oA} + \Omega_{1B} S_{oB} + \Omega_{1U} S_{oU}) (0.2 C_{r1*} + C_i) - (\Omega_{1A} L_{rA} + \Omega_{1B} L_{rB} + \Omega_{1U} L_{rU}) C_{L1*} \quad (5.27b) \end{aligned}$$

where: ΔZ_{r1U} is the salt storage in the root zone of the permanently non-irrigated land, throughout the seasons, when $K_r=1$ (dS/season), ΔZ_{r1*} is the salt storage in the root zone of the land outside the permanently non-irrigated area, when $K_r=1$ (dS/season), C_{L1U} is the salt concentration of the percolation water from the permanently non-irrigated land at the end of the previous time step (dS/m), C_{L1*} is the salt concentration of the percolation water from the land outside the permanently non-irrigated area at the end of the previous time step (dS/m). Ω_{1U} , Ω_{1A} and Ω_{1B} are area weight factors (eqns. 5.28a,b,c).

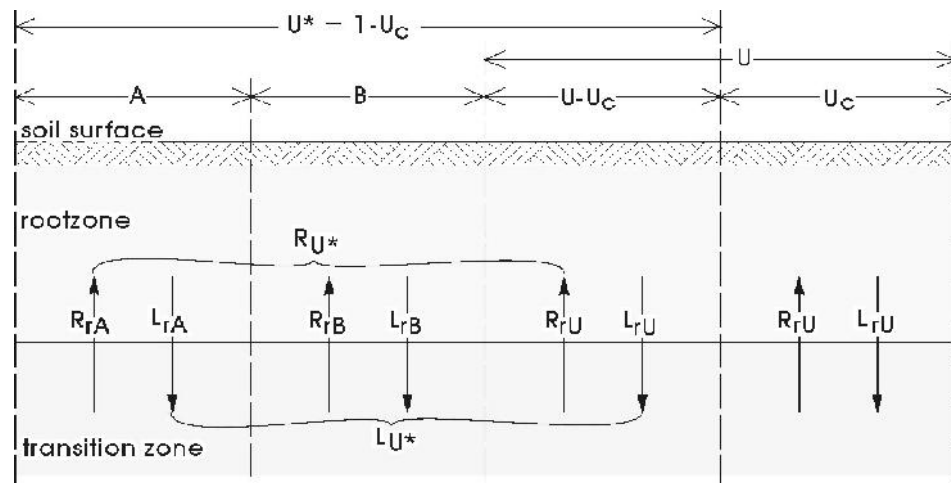

Figure 5.3 Separate hydrological factors in the root zone of the permanently non-irrigated land (U_c) and pooled factors in the remaining rotational land (U^*)

Water table situation 2

When the water table is above the soil surface, eqns. 5.27a,b are changed into:

$$\Delta Z_{r1U} = \lambda_i (C_{si} - C_{L1U}) - \lambda_o (C_{L1U} - C_{xki}) \quad (5.27c)$$

$$\Delta Z_{r1*} = \lambda_i (C_{si} - C_{L1*}) - \lambda_o (C_{L1*} - C_{xki}) \quad (5.27d)$$

Water table situation 3

Eqns. 5.27a,b are used with the value of Z_{si} added to each like in eqn. 58c. Subsequently the value of Z_{si} is made equal to zero.

The weight factors in eqn. 5.27a,b are defined as:

$$\Omega_{1U} = (U-U_c)/(1-U_c) \quad (5.28a)$$

$$\Omega_{1A} = A/(1-U_c) \quad (5.28b)$$

$$\Omega_{1B} = B/(1-U_c) \quad (5.28c)$$

The final salt concentrations of the soil moisture in the root zone are calculated as:

$$C_{r1Uf} = C_{r1Ui} + \Delta Z_{r1U}/P_{tr}D_r \quad (5.29a)$$

$$C_{r1*f} = C_{r1*i} + \Delta Z_{r1*}/P_{tr}D_r \quad (5.29b)$$

5.4.2.3 Transition zone

The salt concentration C_{L1} of the percolation water L_r from the root zone into the transition zone at the end of the previous time step is calculated as the weighed average of the salt concentrations of the percolation water from the U_c and $U^*=1-U_c$ areas.

The percolation L_{rU^*} in the U^* area, i.e. outside the permanently non-irrigated land, expressed in m^3/season per m^2 outside area, is found from:

$$L_{rU^*} = \Omega_{1U}L_{rU} + \Omega_{1A}L_{rA} + \Omega_{1B}L_{rB} \quad (5.30a)$$

and the salt concentration C_{L1} from:

$$C_{L1} = [L_{rU}C_{r1A}U_c + L_{rU^*}C_{r1^*}(1-U_c)]/L_r \quad (5.30b)$$

When the water table is above the soil surface we replace the percolation L_r and capillary rise R_r in eqn. 5.30a,b and other by $L_{rA}=L_{rB}=L_{rU}=\lambda_i$ and $R_{rA}=R_{rB}=R_{rU}=\lambda_o$. The weight factors Ω then play no role.

The other salt balances of the transition zone are calculated using the equations of section 5.2.3.3, C_{L1} replacing C_{L4} .

5.4.3. Part of the irrigated area permanently under group A crop(s), Kr=2

5.4.3.1 Above soil surface

The principles of the salt balance described in sect. 5.2.1 apply equally here.

The amount of salt entering the water body above the soil surface is calculated slightly differently as:

$$Z_{se} = C_i(I_{aA}A + I_{aB}B + S_{iU}U) + C_pP_p + (C_{r2Ai} + C_{r2*i})\lambda_o \quad (5.31)$$

where: C_{r2Ai} is the salt concentration of the soil moisture in the root zone, when saturated, in the permanently irrigated land under group A crop(s), at the start of the time step, equal to the salt concentration of the same at the end of the previous time step (dS/m), C_{r2*i} is the salt concentration of the soil moisture in the root zone, when saturated, of the land outside the permanently irrigated land under group A crop(s) at the start of the time step, equal to the salt concentration of the same at the end of the previous time step (dS/m).

The calculations of Z_{so} , and Z_{sf} remain unchanged.

5.4.3.2 Root zone

Water table situation 1

The salt balance of the root zone (eqn. 5.4a) is split into 2 parts, one separate part for the permanently irrigated area A_c and one pooled part for the remaining area $1 - A_c = A^*$ with full cropping rotation. The two salt balances of the root zone thus read:

$$\Delta Z_{r2A} = P_p C_p + I_{aA} C_i + R_{rA} C_{xki} - S_{oA}(0.2C_{r2Ai} + C_i) - L_{rA} C_{L2A} \quad (5.32a)$$

$$\begin{aligned} \Delta Z_{r2*} = & P_p C_p + (\Omega_{2A} I_{aA} + \Omega_{2B} I_{aB} + \Omega_{2U} S_{iU}) C_i + (\Omega_{2A} R_{rA} + \Omega_{2B} R_{rB} + \Omega_{2U} R_{rU}) C_{xki} \\ & - (\Omega_{2A} S_{oA} + \Omega_{2B} S_{oB} + \Omega_{2U} S_{oU})(0.2C_{r2*i} + C_i) - (\Omega_{2A} L_{rA} + \Omega_{2B} L_{rB} + \Omega_{2U} L_{rU}) C_{L2*} \end{aligned} \quad (5.32b)$$

where: ΔZ_{r2A} is the salt storage in the root zone of the permanently irrigated land under group A crop(s), throughout the seasons, when $K_r=2$ (dS/season), ΔZ_{r2*} is the salt storage in the root zone of the land outside the permanently irrigated area under group A crop(s), when $K_r=2$ (dS/season), C_{L2A} is the salt concentration of the percolation water from the permanently irrigated land under group A crop(s), throughout the seasons, at the end of the previous time step (dS/m), C_{L2*} is the salt concentration of the percolation water from the land outside the permanently irrigated area under group A crops at the end of the previous time step (dS/m). Ω_{2U} , Ω_{2A} and Ω_{2B} are area weight factors (eqns. 5.43a,b,c).

Water table situation 2

When the water table is above the soil surface, eqns. 5.32a,b are changed into:

$$\Delta Z_{r2A} = \lambda_i(C_{si} - C_{L2A}) - \lambda_o(C_{L2A} - C_{xki}) \quad (5.32c)$$

$$\Delta Z_{r2*} = \lambda_i(C_{si} - C_{L2*}) - \lambda_o(C_{L2*} - C_{xki}) \quad (5.32d)$$

Water table situation 3

Eqns. 5.32a,b are used with the value of Z_{si} added to each like in eqn. 5.4c. Subsequently the value of Z_{si} is made equal to zero.

The weight factors in eqn. 5.32a,b are defined as:

$$\Omega_{2A} = (A-A_c)/(1-A_c) \quad (5.33a)$$

$$\Omega_{2B} = B/(1-A_c) \quad (5.33b)$$

$$\Omega_{2U} = U/(1-A_c) \quad (5.33c)$$

The salt concentrations C_{L2A} and C_{L2*} of the percolation water at the end of the previous time step are found from:

$$C_{L2A} = F_{tr}C_{r2A} \quad (5.34a)$$

$$C_{L2*} = F_{tr}C_{r2*} \quad (5.34b)$$

where: C_{r2A} is the salt concentration of the soil moisture in the root zone, when saturated, of the permanently irrigated land under group A crop(s), when $K_r=2$, at the end of the previous time step (dS/m), C_{r2*} is the salt concentration of the soil moisture in the root zone, when saturated, of the land outside the permanently irrigated land under group A crop(s), when $K_r=2$, at the end of the previous time step (dS/m).

The final salt concentrations of the soil moisture in the root zone are calculated as:

$$C_{r2Af} = C_{r2Ai} + \Delta Z_{r2A}/P_{tr}D_r \quad (5.35a)$$

$$C_{r2*f} = C_{r2*i} + \Delta Z_{r2*}/P_{tr}D_r \quad (5.35b)$$

5.4.3.3 Transition zone

The salt concentration C_{L2} of the percolation water L_r from the root zone into the transition zone at the end of the previous time step is calculated as the weighed average of the salt concentrations of the percolation water from the A_c and $A^*=1-A_c$ areas.

The percolation L_{rA^*} in the A^* area, i.e. outside the permanently irrigated land under group A crop(s), expressed in m^3/season per m^2 outside area, is found from:

$$L_{rA^*} = \Omega_{2A}L_{rA} + \Omega_{2B}L_{rB} + \Omega_{2U}L_{rU} \quad (5.36a)$$

and the salt concentration C_{L2} from:

$$C_{L2} = [L_{rA}C_{r2A}A_c + L_{rA^*}C_{rA^*}(1-A_c)]/L_r \quad (5.36b)$$

The other salt balances of the transition zone are calculated using the equations of section 5.2.3 with C_{L4} replaced by C_{L2} .

When the water table is above the soil surface we replace the percolation L_r and capillary rise R_r in eqn. 5.36a,b and other by $L_{rA}=L_{rB}=L_{rU}=\lambda_i$ and $R_{rA}=R_{rB}=R_{rU}=\lambda_o$. The weight factors Ω then play no role.

5.4.4. Part of the irrigated area permanently under group B

crop(s), $K_r=3$

5.4.4.1 Above soil surface

The principles of the salt balance described in sect. 4.3.1 apply equally here.

The amount of salt entering the water body above the soil surface is calculated slightly differently as:

$$Z_{se} = C_i(I_{aA}A + I_{aB}B + S_{iU}U) + C_pP_p + (C_{r03Bi} + C_{r3i+})\lambda_o \quad (5.37)$$

where: C_{r3Bi} is the salt concentration of the soil moisture in the root zone, when saturated, in the permanently irrigated land under group A crop(s), at the start of the time step, equal to the salt concentration of the same at the end of the previous time step (dS/m), C_{r3i} is the salt concentration of the soil moisture in the root zone, when saturated, of the land outside the permanently irrigated land under group A crop(s) at the start of the time step, equal to the salt concentration of the same at the end of the previous time step (dS/m).

The calculations of Z_{so} , and Z_{sf} remain unchanged.

5.4.4.2 Root zone

Water table situation 1

The salt balance of the root zone (eqn. 5.4a) is split into 2 parts, one separate part for the permanently irrigated area B_c and one pooled part for the remaining area $1-B_c=B^*$ with full cropping rotation. The two salt balances of the root zone thus read:

$$\Delta Z_{r3B} = P_p C_p + I_{aB} C_i + R_{rB} C_{xki} - S_{oB}(0.2C_{r3Bi} + C_i) - L_{rB} C_{L2B} \quad (5.38a)$$

$$\begin{aligned} \Delta Z_{r3*} = & P_p C_p + (\Omega_{3A} I_{aB} + \Omega_{3B} I_{aB} + \Omega_{3U} S_{iU}) C_i + (\Omega_{3A} R_{rA} + \Omega_{3B} R_{rB} + \Omega_{3U} R_{rU}) C_{xki} \\ & - (\Omega_{3A} S_{oA} + \Omega_{3B} S_{oB} + \Omega_{3U} S_{oU})(0.2C_{r3*} + C_i) - (\Omega_{3A} L_{rA} + \Omega_{3B} L_{rB} + \Omega_{3U} L_{rU}) C_{L3*} \end{aligned} \quad (5.38b)$$

where: ΔZ_{r3A} is the salt storage in the root zone of the permanently irrigated land under group B crop(s), throughout the seasons, when $K_r=3$ (dS/season), ΔZ_{r3*} is the salt storage in the root zone of the land outside the permanently irrigated area under group B crop(s), when $K_r=3$ (dS/season), C_{L3B} is the salt concentration of the percolation water from the permanently irrigated land under group B crop(s), throughout the seasons, at the end of the previous time step (dS/m), C_{L3*} is the salt concentration of the percolation water from the land outside the permanently irrigated area under group A crops at the end of the previous time step (dS/m). Ω_{3U} , Ω_{3A} and Ω_{3B} are area weight factors (eqns. 5.39a,b,c).

Water table situation 2

When the water table is above the soil surface, eqns. 101a,b are changed into:

$$\Delta Z_{r3A} = \lambda_i(C_{si} - C_{L3A}) - \lambda_o(C_{L3A} - C_{xki}) \quad (5.38c)$$

$$\Delta Z_{r3*} = \lambda_i(C_{si} - C_{L3*}) - \lambda_o(C_{L3*} - C_{xki}) \quad (5.38d)$$

Water table situation 3

Eqns. 5.38a,b are used with the value of Z_{si} added to each like in eqn. 5.4c. Subsequently the value of Z_{si} is made equal to zero.

The weight factors in eqn. 5.38a,b are defined as:

$$\Omega_{3A} = (B-B_c)/(1-B_c) \quad (5.39a)$$

$$\Omega_{3B} = A/(1-B_c) \quad (5.39b)$$

$$\Omega_{3U} = U/(1-B_c) \quad (5.39c)$$

The salt concentrations C_{L3A} and C_{L3*} of the percolation water at the end of the previous time step are found from:

$$C_{L3A} = F_{lr}C_{r3Bv} \quad (5.40a)$$

$$C_{L3*} = F_{lr}C_{r3*v} \quad (5.40b)$$

where: C_{r3Bv} is the salt concentration of the soil moisture in the root zone, when saturated, of the permanently irrigated land under group B crop(s), when $K_r=3$, at the end of the previous time step (dS/m), C_{r3*v} is the salt concentration of the soil moisture in the root zone, when saturated, of the land outside the permanently irrigated land under group B crop(s), when $K_r=3$, at the end of the previous time step (dS/m).

The final salt concentrations of the soil moisture in the root zone are calculated as:

$$C_{r3Bf} = C_{r3Bi} + \Delta Z_{r3B}/P_{lr}D_r \quad (5.41a)$$

$$C_{r3*f} = C_{r3*i} + \Delta Z_{r3*}/P_{lr}D_r \quad (5.41b)$$

5.4.4.3 Transition zone

The salt concentration C_{L3} of the percolation water L_r from the root zone into the transition zone at the end of the previous time step is calculated as the weighed average of the salt concentrations of the percolation water from the B and $B^*=1-B_c$ areas.

The percolation L_{rB^*} in the B^* area, i.e. outside the permanently irrigated land under group B crop(s), expressed in m^3 /season per m^2 outside area, is found from:

$$L_{rB^*} = \Omega_{3A}L_{rA} + \Omega_{3B}L_{rB} + \Omega_{3U}L_{rU} \quad (5.42a)$$

and the salt concentration C_{L3} from:

$$C_{L3} = [L_{rA}C_{r3Bv}A_c + L_{rB^*}C_{rB*v}(1-B_c)]/L_r \quad (5.42b)$$

The other salt balances of the transition zone are calculated using the equations of section 5.2.3 with C_{L4} replaced by C_{L3} .

When the water table is above the soil surface we replace the percolation L_r and capillary rise R_r in eqn. 5.42a,b and other by $L_{rA}=L_{rB}=L_{rU}=\lambda_i$ and $R_{rA}=R_{rB}=R_{rU}=\lambda_o$. The weight factors Ω then play no role.

6. SPATIAL FREQUENCY DISTRIBUTION OF SOIL SALINITY

The spatial variation in soil salinity under irrigated conditions is very high and the variation itself is very dynamic depending upon the agricultural, irrigation and drainage practices. The Gumbel distribution is assumed to fit the cumulative probability distribution of the root zone salinity: it is appropriately skew to the right, and it permits an easy introduction of a standard variation proportional to the mean.

The root zone salinity that is likely to occur at 20%, 40%, 60% and 80% of cumulative frequencies are computed by taking the predicted root zone salinity as the mean.

The cumulative Gumbel distribution, applied to salt concentration C , can be written as:

$$C_{\phi} = \mu - c/\alpha - 1/\alpha \{\ln(-\ln\phi)\} \quad (6.1)$$

where: C_{ϕ} is the value of C at cumulative frequency ϕ (dS/m), μ is the mean of C values (dS/m), c is Euler's constant, equal to 0.577, α equals $\pi/\sigma\sqrt{6}$, and σ is the standard deviation of the C values (dS/m). By assuming the relationship:

$$\sigma = \varepsilon \cdot \mu \quad (6.2)$$

where ε is a constant proportional to the size of the area, eqn. 6.1 is converted to:

$$C_{\phi} = \mu \cdot [0.78\varepsilon - (1 - 0.45\varepsilon) \{\log(-\log\phi)\}] \quad (6.3)$$

In table 6.1 different values are given to ε , depending on the size of the area.

Table 6.1 Values of the proportion $\varepsilon = \sigma/\mu$ in relation to size of the area (ha)

Area lower limit	Area upper limit	ε
0	100	0.35
100	1000	0.41
1000	10000	0.53
10000	100000	0.67

The relation shown in table 1 is empirical, derived from various cases based on traditional soil sampling with an auger up to 30cm depth. Combined or larger size samples would give smaller ε values.

The Gumbel relations used in Sahysmod are arbitrary and need to be verified for a larger number of situations. However, the procedure used at least gives some indication of the possible spatial variations.

Fig. 6.1 shows an example of a Gumbel frequency distribution of soil salinity with a plot of the field data and the line used in Sahysmod. The data are obtained in the traditional way from the Gohana region, Haryana, India, and refer to an area of 2000 ha. In total 400 samples were taken in groups of 4. Per group, the average value is used. The figure is therefore based on 100 data. Their mean value is $\mu=2.98$ and the standard deviation is

$\sigma=0.855$. As the data are averages of 4 samples, which reduces the standard deviation by a factor $1/\sqrt{4}$, the value of ε (0.53, see the previous table) should be reduced to $0.53/\sqrt{4} = 0.265$.

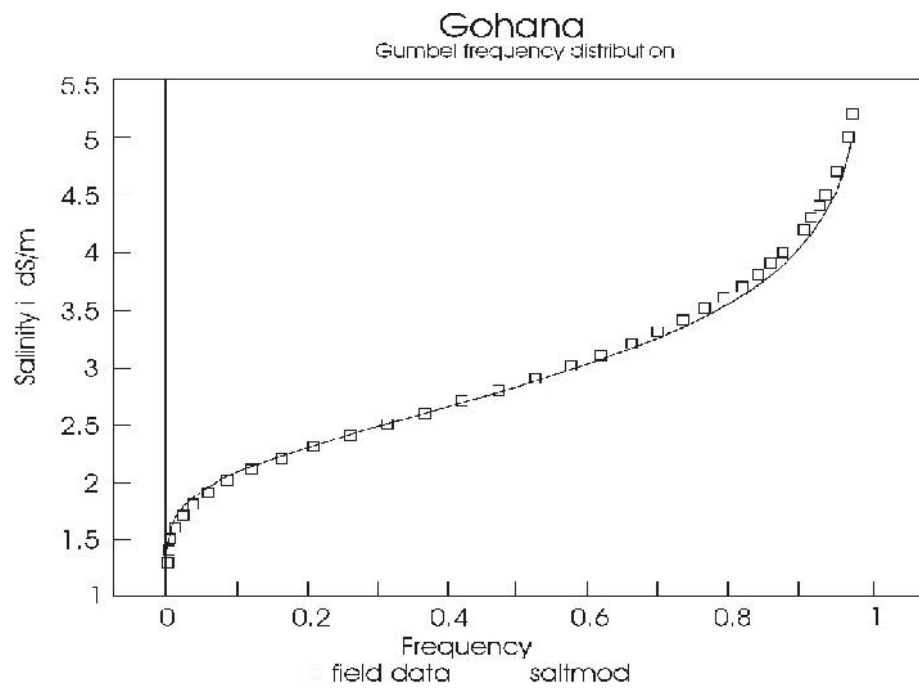

Figure 6.1 Cumulative Gumbel frequency distribution of soil salinity observations in the Gohana area, Haryana, India, and the Sahysmod prediction (data from D.P.Sharma, CSSRI, Karnal, India)

7. FARMERS' RESPONSES

To simulate farmers' responses, the irrigated areas (A and B) can be gradually reduced if the water table becomes shallow, or if the salinity of the root zone becomes high. This is done by defining the farmers' response key $K_f=1$ in the input data file. The responses are the following:

- 1 - a reduction of the irrigated area when the land becomes saline; this leads to an increase in the permanent fallow land, abandoned for agriculture;
- 2 - a reduction of the irrigated area when irrigation water is scarce and the irrigation sufficiency low; this leads to an increase in the rotational fallow land;
- 3 - a decrease of the field application of irrigation water when the water table becomes shallow; this leads to a more efficient field irrigation, reduced percolation, a deeper depth of the water table, and higher soil salinity;
- 4 - a decrease in the abstraction of ground water by pumping from wells when the water table drops.

Response 3 is different for submerged rice and "dry foot" crops.

The responses influence the water and salt balances, which, in their turn, slow down the process of water logging and salinization. Ultimately an equilibrium situation will be brought about.

When Sahysmod is used with intermediate changes in the input data during the whole period of calculation, the response key is automatically set equal to zero, because it is supposed that the adjustments to simulate farmers' responses will be done by the user.

7.1. Reduction of irrigated area when salinization or irrigation deficiency occurs

When the final root zone salinity of the irrigated area under A or B type crops is more than the initial salinity (C_{A0} , C_{B0} , as given with the input), and more than 5 dS/m, or when the irrigation sufficiency (T_A , T_B as calculated by the program) is less than 0.8, the irrigated fractional areas A and B are reduced as follows:

$$A_n = \beta_1 A_p \quad (7.1)$$

$$B_n = \beta_1 B_p \quad (7.2)$$

where: A_n , A_p , B_n and B_p are the A and B values of the next and the present year respectively, and the β_1 values are given in table 7.1.

Table 7.1 Relation between reduction factor β_1 , soil salinity (dS/m) and irrigation sufficiency (-)

Salinity	Sufficiency	β_1
> 10	< 0.7	0.90
5 - 10	0.7 - 0.8	0.95
< 5	> 0.8	1.00

When judging the salinity limits used on may take into account that they are area averages, so that there are patches of land with higher salinity, and that the salinity at field saturation used here is about half the salinity of the commonly used saturation extract. The increased value of the non-irrigated area fraction U is:

$$U_n = 1 - A_n - B_n \quad (7.3)$$

When the soil salinity is greater than 5 dS/m and the value of the rotation key K_r is not equal to 1 (i.e. there is no permanently fallow land), its value is changed into 1, so that the presence of permanently fallow, abandoned, land is assured.

When the sufficiency F_{S_A} and/or F_{S_B} of field irrigation equals unity, then the bypass (I_{on}) of irrigation water in the canal system is increased accordingly:

$$I_{on} = I_{op} + \tau_A(A_p - A_n)I_{aA} + \tau_B(B_p - B_n)I_{aB} \quad (7.4)$$

where: I_{on} and I_{op} are values of bypass I_o in the next and present year respectively, and $\tau_A=1$ when $F_{S_A}=1$, $\tau_B=1$ when $F_{S_B}=1$, otherwise F_{S_A} and F_{S_B} are zero.

At the same time, when the sufficiency is less than one, then the amounts of field irrigation in the reduced areas are increased:

$$I_{An} = I_{Ap} / \beta_1 \quad (7.5a)$$

$$I_{Bn} = I_{Bp} / \beta_1 \quad (7.5b)$$

where: I_{An} , I_{Ap} , I_{Bn} , and I_{Bp} are the amounts of field irrigation I_{aA} and I_{aB} in the A and B areas of the next and present year respectively.

Now, adjustment of the soil salinity values of the permanently non-irrigated area U_c (if $K_r=1$), the permanently irrigated A_c (if $K_r=2$) and B_c (if $K_r=3$) areas is required respectively as follows:

$$C_{1Ufn} = \frac{U_n(1-\beta\beta_1)C_{r1*f} + U_c C_{r1Uf}}{U_n(1-\beta\beta_1) + U_c} \quad (7.6a)$$

$$C_{2Afn} = \frac{A_n(1-\beta_1)C_{r2*f} + A_c C_{r2Af}}{A_n(1-\beta_1) + A_c} \quad (7.6b)$$

$$C_{3Bfn} = \frac{B_n(1-\beta_1)C_{r3*f} + B_c C_{r3Bf}}{B_n(1-\beta_1) + B_c} \quad (7.6c)$$

where: C_{r2An} is the adjusted final salt concentration of the soil moisture, when at field saturation, in the root zone of the permanently irrigated land under group A crop(s), used for the start of the next year, $K_r=2$ (EC in dS/m), C_{r3Bn} is the adjusted final salt concentration of the soil moisture, when at field saturation, in the root zone of the permanently irrigated land under group B crop(s), used for the start of the next year, $K_r=3$ (EC in dS/m), and C_{r1Un} is the adjusted final salt concentration of the soil moisture, when at field saturation, in the root zone of the permanently non-irrigated land, used for the start of the next year, $K_r=1$ (EC in dS/m)

As a result of the area reductions and irrigation increases, it may happen that the salinity in the irrigated areas reduces again. If this brings the soil salinity below their initial levels, as given with the input, then the above processes are reversed (i.e. multiplication with β becomes division and vice versa), but the irrigated areas will not become larger, and the amounts of field irrigation not smaller, than their initial values as given with the input.

7.2. Reduction of irrigation when water logging occurs and adjusting the bypass accordingly

If the depth of water table at the end of the previous season D_w less than less than 0.6 m, the bypass is increased and the irrigation is reduced as follows:

$$I'_{on} = I_{on} + \beta_2(I_{A0}A_p + I_{B0}B_p) \quad (7.7)$$

$$I'_{An} = I_{An} - \beta_2 I_{A0} \quad (7.8a)$$

$$I'_{Bn} = I_{Bn} - \beta_2 I_{B0} \quad (7.8b)$$

where: I'_{An} , I'_{Bn} and I'_{on} are the adjusted values of the field irrigation in the A and B areas and the adjusted value of the bypass for the next year respectively, I_{An} , I_{Bn} and I_{on} are the previously adjusted values (Sect. 7.1) of the field irrigation in the A and B areas and the previously adjusted value of the bypass respectively, I_{A0} and I_{B0} are the initial values of the field irrigation in the A and B areas as given with the input respectively, and A_n and B_n are the adjusted values of the A and B areas as discussed in the previous section, and the reduction factor β_2 is given in table 7.2.

Table 7.2 Relation between average depth of water table D_w (m) and reduction factor β_2

D _w range		β_2
paddy/rice	non-rice	
-0.10 to -0.20	0.5 - 0.6	0.05
-0.20 to -0.25	0.4 - 0.5	0.10
-0.25 to -0.30	0.3 - 0.4	0.15
-0.30 to -0.35	0.2 - 0.3	0.20
-0.35 to -0.40	0.1 - 0.2	0.25
> -0.40	< 0.2	0.30

The reductions of the field irrigation due to presence of a shallow water table may reinforce or attenuate the irrigation adjustments discussed in the previous section. When, due to the area reductions discussed in the previous section, the water table drops again to greater depths, then above processes are reversed, (addition instead of subtraction and vice versa) but the irrigation will not become greater than the initial irrigation given with the input.

7.3. Reduction of ground-water abstraction by pumping from wells when the water table drops

When the water table drops, the ground-water abstraction by pumping from wells (G_w) is conditionally reduced as follows:

$$G_w = G_{w0}H_w/H_{w0} \quad (7.9)$$

where: G_{w0} is the initial seasonal well abstraction in year 1 (m^3 /season per m^2 total area of the polygon), and H_{w0} is the initial height of the water level of the polygon in year 1 (m).

The reduction occurs only when $H_w < H_{w0}$.

8. ALPHABETICAL LIST OF SYMBOLS

A	Fraction of total area occupied by irrigated group A crops (-)
A_b	Surface area of node b (m^2)
A_c	Fraction of total area permanently occupied by irrigated group A crops throughout the seasons (-)
A_n	Adjusted fraction of total area occupied by irrigated group A crops for the next year (-)
A_p	Fraction of total area occupied by irrigated group A crops in the present year (-)
α	Factor inversely proportional to the standard deviation of salt concentration expressed in EC (m/dS)
B	Fraction of total area occupied by irrigated group B crops (-)
B_c	Fraction of total area permanently occupied by irrigated group B crops throughout the seasons (-)
B_L	Bottom level of the aquifer (m)
B_{Lb}	Value of B_L in polygon b (m)
B_{Lj}	Value of B_L in neighboring polygon j (m)
B_n	Adjusted fraction of total area occupied by irrigated group B crops for the next year (-)
B_p	Fraction of total area occupied by irrigated group B crops in the present year (-)
β_1	Reduction factor of irrigated area fractions (-)
β_2	Reduction factor for irrigation applications (-)
β_c	Integration constant
c	Euler constant (-)
C	Salt concentration (dS/m)
C_{ai}	Salt concentration of the incoming ground water through the aquifer into a polygon (dS/m)
C_d	Salt concentration of the drainage water (EC in dS/m)
C_Φ	Salt concentration at cumulative frequency Φ (EC in dS/m)
C_g	Salt concentration of the capillary rise (EC in dS/m)
C_{gp}	Salt concentration of the capillary rise at the end of the previous time step, depending on the presence or absence of a subsurface drainage system (EC in dS/m)
C_i	Salt concentration of the surface irrigation water including the use of drain or well water for irrigation (dS/m)
C_{ic}	salt concentration of the inflowing canal water at the end of the previous time step (EC in dS/m)
C_{inf}	Salt concentration of the boundary inflow (EC in dS/m)
C_L	Salt concentration of percolation water (EC in dS/m)
C_{L0}	Salt concentration of the percolation water to the transition zone when $K_r=0$ (EC in dS/m)
C_{L0A}	Salt concentration of the percolation water from the irrigated group A crop(s) when $K_r=0$ (EC in dS/m)
C_{L0B}	Salt concentration of the percolation water from the irrigated group B crop(s) when $K_r=0$ (EC in dS/m)
C_{L0U}	Salt concentration of the percolation water from the non-irrigated land when $K_r=0$ (EC in dS/m)

C_{L1U}	Salt concentration of the percolation water from the permanently non-irrigated land when $K_r=1$ (EC in dS/m)
C_{L1*}	Salt concentration of the percolation water from the land outside the permanently non-irrigated area when $K_r=1$ (EC in dS/m)
C_{L2A}	Salt concentration of the percolation water from the permanently irrigated land under group A crop(s) when $K_r=2$ (EC in dS/m)
C_{L2*}	Salt concentration of the percolation water from the land outside the permanently irrigated area under group A crop(s) when $K_r=2$ (EC in dS/m)
C_{L3B}	Salt concentration of the percolation water from the permanently irrigated land under group B crop(s) when $K_r=3$ (EC in dS/m)
C_{L3*}	Salt concentration of the percolation water from the land outside the permanently irrigated area under group B crop(s) when $K_r=3$ (EC in dS/m)
C_{L4}	Salt concentration of percolation water when $K_r=4$ (EC in dS/m)
C_{qi}	Salt concentration of the water in the aquifer, when saturated, at the end of the previous time step (EC in dS/m)
C_{qj}	Value of C_{qi} in neighboring polygon j (EC in dS/m)
C_{qf}	Salt concentration of the water in the aquifer, when saturated, at the end of the time step (EC in dS/m)
C_r	Salt concentration of the water in a reservoir (EC in dS/m)
C_{r0Af}	Salt concentration of the soil moisture in the root zone, when saturated, of the group A crop(s), when $K_r=0$, at the end of the time step (EC in dS/m)
C_{r0Ai}	Salt concentration of the soil moisture in the root zone, when saturated, of the group A crop(s), when $K_r=0$, at the start of the time step, equal to the salt concentration of the same at the end of the previous time step (EC in dS/m)
C_{r0Bf}	Salt concentration of the soil moisture in the root zone, when saturated, of the group B crop(s), when $K_r=0$, at the end of the time step (EC in dS/m)
C_{r0Bi}	Salt concentration of the soil moisture in the root zone, when saturated, of the group B crop(s), when $K_r=0$, at the start of the time step, equal to the salt concentration of the same at the end of the previous time step (EC in dS/m)
C_{r0Uf}	Salt concentration of the soil moisture in the root zone, when saturated, of the non-irrigated land, when $K_r=0$, at the end of the time step (EC in dS/m)
C_{r0Ui}	Salt concentration of the soil moisture in the root zone, when saturated, of the non-irrigated land, when $K_r=0$ at the start of the time step, equal to the salt concentration of the same at the end of the previous time step (EC in dS/m)
C_{r1Uf}	Salt concentration of the soil moisture in the root zone, when saturated, in the permanently non-irrigated land, when $K_r=1$, at the end of the time step (dS/m)
C_{r1Ui}	Salt concentration of the soil moisture in the root zone, when saturated, in the permanently non-irrigated land, when $K_r=1$, at the start of the time step, equal to the salt concentration of the same at the end of the previous time step (dS/m)
C_{r1Un}	Adjusted final salt concentration of the soil moisture, when at field saturation, in the root zone of the permanently non-irrigated land, used for the start of the next year, $K_r=1$ (EC in dS/m)
C_{r1*f}	Salt concentration of soil moisture in the root zone, when saturated, of the land outside the permanently non-irrigated area, when $K_r=1$, at the end of the time step (dS/m).
C_{r1*i}	Salt concentration of the soil moisture in the root zone, when saturated, of the land outside the permanently non-irrigated area, when $K_r=1$, at the start of the time step, equal to the salt concentration of the same at the end of the previous time step (dS/m)

- C_{r2Af} Salt concentration of the soil moisture in the root zone, when saturated, in the permanently irrigated land under group A crop(s), when $K_r=2$, at the end of the time step (dS/m)
- C_{r2Ai} Salt concentration of the soil moisture in the root zone, when saturated, in the permanently irrigated land under group A crop(s), when $K_r=2$, at the start of the time step, equal to the salt concentration of the same at the end of the previous time step (dS/m)
- C_{r2An} Adjusted final salt concentration of the soil moisture, when at field saturation, in the root zone of the permanently irrigated land under group A crop(s), used for the start of the next year, $K_r=2$ (EC in dS/m)
- C_{r2*f} Salt concentration of the land outside the permanently irrigated land under group a crop(s), when $K_r=2$, at the end of the time step (dS/m)
- C_{r2*i} Salt concentration of the soil moisture in the root zone, when saturated, of the land outside the permanently irrigated land under group a crop(s), when $K_r=2$, at the start of the time step, equal to the salt concentration of the same at the end of the previous time step (dS/m)
- C_{r3Bf} Salt concentration of the soil moisture in the root zone, when saturated, in the permanently irrigated land under group B crop(s), when $K_r=3$, at the end of the time step (dS/m)
- C_{r3Bi} Salt concentration of the soil moisture in the root zone, when saturated, in the permanently irrigated land under group B crop(s), when $K_r=2$, at the start of the time step, equal to the salt concentration of the same at the end of the previous time step (dS/m)
- C_{r3Bn} Adjusted final salt concentration of the soil moisture, when at field saturation, in the root zone of the permanently irrigated land under group B crop(s), used for the start of the next year, $K_r=3$ (EC in dS/m)
- C_{r3*f} Salt concentration of the soil moisture in the root zone, when saturated, of the land outside the permanently irrigated land under group a crop(s), when $K_r=3$, at the end of the time step (dS/m)
- C_{r3*i} Salt concentration of the soil moisture in the root zone, when saturated, of the land outside the permanently irrigated land under group a crop(s), when $K_r=3$, at the start of the time step, equal to the salt concentration of the same at the end of the previous time step (dS/m)
- C_{r4f} Salt concentration of the soil moisture in the root zone, when saturated and $K_r=4$, at the end of the time step, (EC in dS/m)
- C_{r4i} Salt concentration of the soil moisture in the root zone, when saturated, at end of the previous time step, and $K_r=4$ (EC in dS/m)
- C_{ti} Salt concentration of incoming ground water through the transition zone into a polygon (dS/m)
- C_{xaf} Salt concentration of the water in the part of the transition zone above drain level, when saturated, at the end of the time step (EC in dS/m)
- C_{xai} Salt concentration of the water in the part of the transition zone above drain level, when saturated, at the start of the time step, equal to the same at the end of the previous time step (EC in dS/m)
- C_{xbf} Salt concentration of the water in the transition zone below drain level, when saturated, at the end of the time step (EC in dS/m)
- C_{xbi} Salt concentration of the water in the transition zone below drain level, when saturated, at the start of the time step, equal to the same at the end of the previous time step (EC in dS/m)

C_{xf}	Salt concentration of the water in the transition zone, when saturated, at the end of the time step (EC in dS/m)
C_{xi}	Salt concentration of the water in the transition zone, when saturated, at the start of the time step, equal to the same at the end of the previous time step (EC in dS/m)
C_{xj}	Value of C_{xi} in neighboring polygon j (dS/m)
C_{U1f}	Salt concentration of the soil moisture, when at field saturation, in the root zone of the permanently non-irrigated land at the end of the time step, $K_r=1$ (EC in dS/m)
C_{U1*f}	Salt concentration of the soil moisture, when at field saturation, in the root zone of the land outside the permanently non-irrigated land at the end of the time step, $K_r=1$ (EC in dS/m)
C_{U1n}	Adjusted final salt concentration of the soil moisture, when at field saturation, in the root zone of the permanently non-irrigated land, used for the start of the next year, $K_r=1$ (EC in dS/m)
C_w	salt concentration of the pumped well water at the end of the previous time step (EC in dS/m)
D	Thickness of a reservoir (m)
D_a	Saturated thickness of the slowly permeable covering layer in a semi-confined aquifer (m)
D_{ai}	Value of D_a at time t_i (m)
D_{bj}	Average depth of the saturated part of the un-confined aquifer between node b and neighboring node j (m)
D_c	Critical depth of the water table for capillary rise (m), $D_c > D_r$
D_d	Depth of subsurface drains (m), $D_r < D_d < D_r + D_t$
D_e	Hooghoudt's equivalent depth of the impermeable layer (m)
D_q	Saturated thickness of the aquifer (m)
D_{qb}	Value of D_q in node b (m)
D_{qj}	Value of D_q in neighboring node j (m)
D_{bj}	Average value of D_{qb} and D_{qj} (m)
D_r	Thickness of the root zone (m), $D_r > 0.1 > D_{cr}$
D_{rb}	Value of D_r in polygon b (m)
D_{rj}	Value of D_r in neighboring polygon j (m)
D_q	Saturated thickness of the aquifer (m)
D_{qb}	Value of D_q in polygon b (m)
D_{qj}	Value of D_q in neighboring polygon j (m)
D_x	Thickness of the transition zone between root zone and aquifer (m)
D_{xb}	Value of D_x in polygon b (m)
D_{xj}	Value of D_x in neighboring polygon j (m)
D_{bj}	Average value of D_{qb} and D_{qj} (m)
D_w	depth of the water table below the soil surface at the end of the previous time step (m)
D_v	Thickness of a semi-confining layer
ΔW_q	Change in storage of water in the aquifer (m^3/day per m^2 total area)
ΔW_r	Storage of water in the root zone reservoir (m^3/day per m^2 total area)
ΔW_s	Storage of water in the surface reservoir (m^3/day per m^2 total area)
ΔW_x	Storage of water in the transition zone (m^3/day per m^2 total area)
ΔW	Total storage of water (m^3/day per m^2 total area)
ΔZ_{r0A}	Salt storage in the root zone of the irrigated group A crop(s) when $K_r=0$ (dS/day)
ΔZ_{r0B}	Salt storage in the root zone of the irrigated group B crop(s) when $K_r=0$ (dS/day)

ΔZ_{r0U}	Salt storage in the root zone of the non-irrigated land when $K_r=0$ (dS/day)
ΔZ_{r1U}	Salt storage in the root zone of the permanently non-irrigated land, throughout the seasons, when $K_r=1$ (dS/day)
ΔZ_{r1*}	Salt storage in the root zone of the land outside the permanently non-irrigated area, when $K_r=1$ (dS/day)
ΔZ_{r2A}	Salt storage in the root zone of the permanently irrigated land under group A crop(s), throughout the seasons, when $K_r=1$ (dS/day)
ΔZ_{r2*}	Salt storage in the root zone of the land outside the permanently irrigated land under group A crop(s), when $K_r=1$ (dS/day)
ΔZ_{r3B}	Salt storage in the root zone of the permanently irrigated land under group B crop(s), throughout the seasons, when $K_r=3$ (dS/day)
ΔZ_{r3*}	Salt storage in the root zone of the land outside the permanently irrigated land under group B crop(s), when $K_r=3$ (dS/day)
ΔZ_{r4}	Salt storage in the root zone when $K_r=4$ (dS/day)
ΔZ_x	Salt storage in the transition zone (dS/day)
ΔZ_{xa}	Salt storage in the part of the transition zone above drain level (dS/day)
ΔZ_{xb}	Salt storage in the part of the transition zone below drain level (dS/day)
ΔZ_q	Salt storage in the aquifer (dS/day)
E_a	Total actual evapo-transpiration (m^3 per m^2 total area)
E_{aA}	Actual evapo-transpiration (m^3 per m^2 irrigated area under group A crop(s))
E_{aB}	Actual evapo-transpiration (m^3 per m^2 irrigated area under group B crop(s))
E_{aU}	Actual evapo-transpiration (m^3 per m^2 non-irrigated area)
E_{ra}	Actual evapo-transpiration from the root zone (m^3 per m^2 non-irrigated area)
E_{pA}	Potential evapo-transpiration of irrigated group A crop(s) (m^3 per m^2 irrigated area under group A crops)
E_{pB}	Potential evapo-transpiration of the irrigated group B crop(s) (m^3 per m^2 irrigated area under group B crops)
E_{pU}	Potential evapo-transpiration of the non-irrigated area (m^3 per m^2 non-irrigated area)
ε	Proportionality factor (-)
η_t	Saturated thickness of the top layer of a semi confined aquifer(m)
η_{tb}	Value of η_t in node b (m)
η_{tj}	Value of η_t in neighboring node j (m)
η_{bj}	Average value of η_b and η_{tj} (m)
F_c	Capillary rise factor (-)
F_{dc}	Reduction factor for the drainage function for water table control (fraction)
F_{fA}	Field irrigation efficiency of group A crop(s) (-)
F_{fB}	Field irrigation efficiency of group B crop(s) (-)
F_{ft}	Total field irrigation efficiency (-)
F_l	Leaching efficiency (-)
F_{lq}	Leaching efficiency of the aquifer (-)
F_{lqj}	Leaching efficiency of the aquifer in the neighboring polygon j (-)
F_{lr}	Leaching efficiency of the root zone (-)
F_{lx}	Leaching efficiency of the transition zone (-)

F_{sA}	Storage efficiency of irrigation and rain water in irrigated land under group A crop(s): fraction of irrigation and rainwater stored in the root zone of A crop(s) as an average for all irrigations and rain storms (-)
F_{sB}	Storage efficiency of irrigation and rain water in irrigated land under group B crop(s): fraction of irrigation and rain water stored in the root zone of B crop(s) as an average for all irrigations and rain storms (-)
F_{sU}	Efficiency of rain water in non-irrigated land: fraction of rainwater stored in the root zone of non-irrigated lands as an average for all rain storms (-)
F_w	Fraction of pumped well water used for irrigation (-), $0 < F_w < 1$
φ	Cumulative frequency (-)
G_a	Subsurface drainage water originating from ground water flow above drain level (m^3 per m^2 total area)
G_z	Subsurface drainage water originating from ground water flow below drain level (m^3 per m^2 total area)
G_c	Total rate of controlled subsurface drainage (m^3/day per m^2 total area)
G_{ca}	Rate of controlled subsurface drainage originating from ground water flow above drain level (m^3/day per m^2 total area)
G_{cz}	Rate of controlled subsurface drainage originating from ground water flow below drain level (m^3/day per m^2 total area)
G_d	Total amount of subsurface drainage water (m^3 per m^2 total area)
G_a	Rate of subsurface drainage originating from ground water flow above drain level (m^3/day per m^2 total area)
G_t	Total rate of subsurface drainage (m^3/day per m^2 total area)
G_u	The part of the subsurface drainage water used for irrigation (m^3 per m^2 total area)
G_i	Horizontally incoming ground water flow into a polygon through the aquifer (m^3/day)
G_o	Horizontally outgoing ground water flow from a polygon through the aquifer (m^3/day)
G_{bj}	Ground water flow through the aquifer into polygon b through one side from neighboring polygon j (m^3/day)
G_{jb}	Ground water flow through the aquifer from polygon b through one side to a neighboring polygon j (m^3 per m^2 total area)
G_{si}	Seasonally incoming ground water flow into a polygon through the aquifer (m^3 per m^2 total area)
G_{so}	Seasonally outgoing ground water flow from a polygon through the aquifer (m^3 per m^2 total area)
G_w	Ground water pumped from wells in the aquifer (m^3 per m^2 total area)
G_{w0}	Value of G_w in year 1 ($m^3/season$ per m^2 total area)
χ_i	Horizontally incoming ground water flow into a polygon through the transition zone (m^3/day)
χ_o	Horizontally outgoing ground water flow from a polygon through transition zone (m^3/day)
χ_{bj}	Ground water flow through transition zone into polygon b through one side from neighboring polygon j (m^3/day)
χ_{jb}	Ground water flow through transition zone from polygon b through one side to a neighboring polygon j (m^3 per m^2 total area)
χ_{si}	Seasonally incoming ground water flow into a polygon through transition zone (m^3 per m^2 total area)

χ_{so}	Seasonally outgoing ground water flow from a polygon through transition zone (m^3 per m^2 total area)
H	Hydraulic head (m)
H_q	Value of H in the permeable subsoil of a semi-confined aquifer (m)
H_{qb}	Value of H_q in node b (m)
H_{qj}	Value of H_b in neighboring node j (m)
H_{qi}	Initial value of H_q at time t_i (m)
H_{qf}	Final value of H_q at time t_f in neighboring node j (m)
H_f	Elevation of the water table above a semi confined aquifer (m)
H_{fi}	Initial value of H_f at time t_i (m)
H_{ff}	Final value of H_f at time t_f (m)
H_w	Elevation of the water table in an unconfined aquifer(m)
H_{wb}	Value of H_w in node b (m)
H_{wj}	Value of H_w in neighboring node j (m)
H_{wi}	Initial value of H_w at time t_i (m)
H_{wf}	Final value of H_w at time t_f (m)
H_{w0}	Initial value of H_w in year 0 (m)
I_{aA}	Irrigation water applied to the irrigated fields under group A crop(s) (m^3/day per m^2 area under group A crops)
I_{aB}	Irrigation water applied to the irrigated fields under group B crop(s) (m^3/day per m^2 area under group B crops)
I_{An}	Irrigation water to be applied to the irrigated fields under group A crop(s) in the next year (m^3/day per m^2 area under group A crops)
I_{Ap}	Irrigation water applied to the irrigated fields under group A crop(s) in the present year (m^3/day per m^2 area under group A crops)
I_{Bn}	Irrigation water to be applied to the irrigated fields under group B crop(s) in the next year (m^3/day per m^2 area under group B crops)
I_{Bp}	Irrigation water applied to the irrigated fields under group A crop(s) in the present year (m^3/day per m^2 area)
I_c	Part of the irrigation application recovered after percolation by capillary rise (m/day)
I_f	Amount of irrigation water applied to the fields (m^3/day per m^2 total area)
I_g	Gross amount of field irrigation water (m^3/day per m^2 total area)
I_i	Irrigation water supplied by the canal system (m^3/day per m^2 total area)
I_o	Water leaving the area through the irrigation canal system (m^3/day per m^2 total area)
I_t	Total amount of irrigation water applied, including the percolation losses from the canals, the use of drainage and/or well water, and the bypass (m^3/day per m^2 total area)
j	identification number of a neighboring node (-)
J_{eA}	Field irrigation effectiveness of group A crops (-)
J_{eB}	Field irrigation effectiveness of group B crops (-)
J_{et}	Total field irrigation effectiveness (-)
J_{sA}	Field irrigation sufficiency of group A crops (-)
J_{sB}	Field irrigation sufficiency of group B crops (-)
J_{st}	Total field irrigation sufficiency (-)
K_a	Hydraulic conductivity of the soil above drainage level (m/day)
K_b	Hydraulic conductivity of the soil below drainage level (m/day)

K_{bj}	Horizontal hydraulic conductivity of the un-confined aquifer between node b and neighboring node j (m/day)
K_c	Vertical hydraulic conductivity of the slowly permeable covering layer in a semi-confined aquifer (m/day)
K_d	Key for the presence of a subsurface drainage system: yes -> $K_d=1$, no -> $K_d = 0$
K_f	Key for farmers' responses to water logging, salinization or irrigation scarcity: yes -> $K_f=1$, no -> $K_f=0$
K_r	Key for rotational type of agricultural land use (-). $K_r = 0, 1, 2, 3$ or 4 . Possible land-use types are: irrigated land under group A crops, irrigated land under crops group B crops, and non-irrigated land (U); $K_r=0$ no rotation $K_r=4$ full rotation $K_r=1$ part or all of the U-type land remains permanently as such, the remaining land is under full rotation $K_r=2$ part or all of the A-type land remains permanently as such, the remaining land is under full rotation $K_r=3$ part or all of the B-type land remains permanently as such, the remaining land is under full rotation
K_s	Hydraulic conductivity of the saturated soil for horizontal flow (m/day)
l_b	Number of sides of polygon b through which horizontal inflow of ground water occurs (-)
L_c	Percolation from the irrigation canal system (m^3 per m^2 total area)
L_r	Percolation from the root zone (m^3 per m^2 total area)
L_{rA}	Percolation from the root zone (m^3 per m^2 irrigated area under group A crops)
L_{rB}	Percolation from the root zone (m^3 per m^2 irrigated area under group B crops)
L_{rT}	Total percolation from the root zone (m^3 per m^2 total area)
L_{rU}	Percolation from the root zone in the non-irrigated area (m^3 per m^2 non-irrigated area)
λ_i	In-filtration through the soil surface into the root zone (m^3 per m^2 non-irrigated area)
λ_o	Ex-filtration through the soil surface from the root zone (m^3 per m^2 non-irrigated area)
m_b	Number of sides of polygon b through which horizontal outflow of ground water occurs (-)
μ	Mean value of soil salinity used in the Gumbel frequency distribution (EC in dS/m)
n_b	Number of sides of polygon b (-)
N_s	Number of seasons per year, min. 1, max. 4
N_y	Number of years for model running (-), max. 99

Ω_{1A}	Weight factor for the irrigated land under group A crop(s) in the presence of permanently non-irrigated land, $K_r=1$ (-)
Ω_{1B}	Weight factor for the irrigated land under group B crop(s) in the presence of permanently non-irrigated land, $K_r=1$ (-)
Ω_{2A}	Weight factor for the irrigated land under group A crop(s) outside the permanently irrigated land under group A crop(s), $K_r=2$ (-)
Ω_{2B}	Weight factor for the part of the irrigated land under group B crop(s) outside the permanently irrigated land under group A crop(s), $K_r=2$ (-)
Ω_{2U}	Weight factor for the part of the non-irrigated area in the presence of permanently irrigated land under group A crop(s), $K_r=2$ (-)
Ω_{3A}	Weight factor for the irrigated land under group A crop(s) in the presence of permanently irrigated land under group B crop(s), $K_r=2$
Ω_{3B}	Weight factor for the part of the irrigated land under group B crop(s) outside the permanently irrigated land under group B crop(s), $K_r=3$ (-)
Ω_{3U}	Weight factor for the part of the non-irrigated area in the presence of permanently irrigated land under group B crop(s), $K_r=3$ (-)
P_{ei}	Effective porosity, drainable or refillable pore space in the reservoir where the water table is located (m/m)
P_{eib}	Value of P_{ei} in polygon b (m/m)
P_{er}	Effective porosity (drainable or refillable pore space) of the root zone (m/m)
P_{eq}	Effective porosity (drainable or refillable pore space) of the aquifer (m/m)
P_{ex}	Effective porosity (drainable or refillable pore space) of the transition zone (m/m)
P_p	Rainfall/precipitation (m^3 per m^2 total area)
P_{sq}	Storativity or specific yield of the highly permeable subsoil in a semi-confined aquifer (m/m)
P_{tq}	Total pore space of the aquifer (m/m)
P_{tr}	Total pore space of the root zone (m/m)
P_{tx}	Total pore space of the transition zone (m/m)
Q_{H1}	Ratio of drain discharge and height of the water table above drain level (m/day per m)
Q_{H2}	Ratio of drain discharge and squared height of the water table above drain level (m/day per m^2)
Q_{inf}	Inflow boundary condition (m^3 per m^2 total area)
Q_{out}	Outflow boundary condition (m^3 per m^2 total area)
R_a	Apparent amount of capillary rise into the root zone (m/day)
R_r	Capillary rise into the root zone (m^3 per m^2 total area)
R_{rA}	Capillary rise into the root zone (m^3 per m^2 irrigated area under group A crops)
R_{rB}	Capillary rise into the root zone (m^3 per m^2 irrigated area under group B crops)
R_{rT}	Capillary rise into the root zone (m^3 per m^2 total area)
R_{rU}	Capillary rise into the root zone of the non-irrigated land (m^3 per m^2 non-irrigated area)
ρ_1	Average saturated thickness of the transition zone between the unconfined polygon b and the neighboring semi confined polygon b (m)
ρ_2	Average saturated thickness of the transition zone between the semi confined polygon b and the neighboring unconfined polygon b (m)

S_{iU}	Surface inflow of water from surroundings into the non-irrigated area (m^3 per m^2 non-irrigated area)
S_L	Level of the soil surface (m)
S_{Lb}	Value of S_L in polygon b (m)
S_{Lj}	Value of S_L in neighboring polygon j (m)
S_{oA}	Outgoing surface runoff or surface drain water from irrigated land under group A crop(s) (m^3 per m^2 irrigated area under group A crops)
S_{oB}	Outgoing surface runoff or surface drain water from irrigated land under group B crop(s) (m^3 per m^2 irrigated area under group B crops)
S_{oU}	Outgoing surface runoff water from the non-irrigated area (m^3 per m^2 non-irrigated area)
σ	Standard deviation of soil salinity used in the Gumbel frequency distribution (dS/m)
t	Time (day)
t_i	Initial value of a time interval (day)
t_f	Final value of a time interval (day)
T_s	Duration of the season (months)
T_v	Transmissivity of a semi-confining layer (m^2/day)
T_{vb}	Value of T_v in node b (m^2/day)
T_{vj}	Value of T_v in neighboring node j (m^2/day)
τ	Dummy variable (-)
θ_t	Saturated thickness of the transition zone in an unconfined aquifer(m)
θ_{tb}	Value of θ_t in node b (m)
θ_{tj}	Value of θ_t in neighboring node j (m)
θ_{bj}	Average value of θ_{tb} and θ_{tj} (m)
Θ_{bj}	Average transmissivity of the confining layer in node b and the layer with the same thickness in the transition zone of neighboring node j with an unconfined aquifer (m^2/day)
Θ_{bj}	Average transmissivity of the confining layer in neighboring node j and the layer with the same thickness in the transition zone of node b with an unconfined aquifer (m^2/day)
U	Non-irrigated fraction of total area (-)
U_c	Permanently non-irrigated fraction of total area throughout the seasons (-)
U_n	Adjusted non-irrigated fraction of total area for next year (-)
V_L	Velocity of vertical downward drainage into the aquifer (m/day)
V_R	Velocity of vertical upward seepage from the aquifer (m/day)
V_w	Vertical flow velocity at the top of the aquifer (m/day)
V_{wi}	Value of V_w at time t_i (m/day)
V_A	Surface water resources in the irrigated area under group A crop(s) (m^3 per m^2 irrigated area under group A crops)
V_B	Surface water resources in the irrigated area under group B crop(s) (m^3 per m^2 irrigated area under group B crops)
V_L	Vertical downward drainage into the aquifer (m^3 per m^2 total area)
V_{Li}	Value of V_L at time t_i (m/day)
V_R	Vertical upward seepage from the aquifer (m^3 per m^2 total area)
V_{Ri}	Value of V_R at time t_i (m/day)
V_s	Total surface water resources (m^3 per m^2 total area)
V_U	Surface water resources in the non-irrigated area (m^3 per m^2 non-irrigated area)

V_{wb}	Amount of vertical flow into or out of the saturated soil body in node b (m/day)
W_{bj}	Length of side between nodal point b and neighboring nodal point j (m)
X	Distance along the horizontal x-coordinate (m)
Y	Distance along the horizontal y-coordinate (m)
Y_s	Spacing of parallel subsurface drains (m)
Z_{bj}	Distance between nodal point b and neighboring nodal point j (m)
Z_e	Amount of salt entering the surface reservoir (m.dS/m)
Z_f	Final amount of salt stored above the soil surface (m.dS/m)
Z_i	Initial amount of salt stored above the soil surface (m.dS/m)
Z_o	Amount of salt leaving the surface reservoir (m.dS/m)
ζ_{qi}	Daily amount of incoming salts through the aquifer (dS/m x m ³ /day)
ζ_{xi}	Daily amount of incoming salts through the transition zone (dS/m x m ³ /day)
ζ_{sq}	Seasonal amount of incoming salts through the aquifer (dS/m x m/season)
ζ_{sx}	Seasonal amount of incoming salts through the transition zone (dS/m x m/season)

9. USER MENU

For the DOS versions of SahysMod, the user menu was extensively described. The present Windows version is supposed to be self explanatory.

10 LIST OF SYMBOLS OF INPUT DATA

The symbols of input data used in the computer program are slightly different from those used in the description of the theory due to the difference in possibilities between a programming language and a word processor.

In some of the following symbols of input variables the sign # is used to indicate the season number: # = 1, 2, 3, or 4

A#	Fraction of total area occupied by irrigated group A crops in season # (-), $0 < A# < 1$
B#	Fraction of total area occupied by irrigated group B crops in season # (-), $0 < B# < 1$
BL	Bottom level of an aquifer (m)
Cic#	Salt concentration of the incoming canal water (EC in dS/m)
Cin	Salt concentration of Q_{inf} , the aquifer inflow condition (EC in dS/m)
CA0	Initial salt concentration of the soil moisture, when at field saturation, in the root zone of the irrigated land under group A crop(s) (EC in dS/m)
CB0	Initial salt concentration of the soil moisture, when at field saturation, in the root zone of the irrigated land under group B crop(s) (EC in dS/m)
Cq0	Initial salt concentration of the ground water in the aquifer (EC in dS/m)
Cx0	Initial salt concentration of the soil moisture in the transition zone (EC in dS/m)
Cxa0	Initial salt concentration of the ground water in the upper part of the transition zone, i.e. above drain level (EC in dS/m)
Cxb0	Initial salt concentration of the ground water in the lower part of the transition zone, i.e. below drain level (EC in dS/m)
CU0	Initial salt concentration of the soil moisture, when at field saturation, in the root zone of the non-irrigated land (EC in dS/m)
Da	Thickness of the aquifer (m)
Dcr	Critical depth of the water table for capillary rise (m), $D_{cr} > D_r$
Dd	Depth of subsurface drains (m), $D_d > D_r$
Dr	Thickness of the root zone (m), $D_r > 0.1 > D_{cr}$
Dx	Thickness of the transition zone between root zone and aquifer (m)
EpA#	Potential evapo-transpiration of irrigated group A crop(s) in season # (m^3 /season per m^2 irrigated area under group A crops)
EpB#	Potential evapo-transpiration of irrigated group B crop(s) in season # (m^3 /season per m^2 irrigated area under group B crops)
EpU#	Potential evapo-transpiration of non-irrigated area in season # (m^3 /season per m^2 non-irrigated area)
Flq	Leaching efficiency of the aquifer (-), $Fl_q > 0$
Flr	Leaching efficiency of the root zone (-), $Fl_r > 0$
Flx	Leaching efficiency of the transition zone (-), $Fl_x > 0$
Frd	Reduction factor for the drainage function for water table control (-)

FsA#	Seasonal storage efficiency of irrigation and rain water in irrigated land under group A crop(s): fraction of irrigation and rainwater stored in the root zone of A crop(s), average of all irrigations and rain storms (-), $0 < FsA < 1$
FsB#	Seasonal storage efficiency of irrigation and rain water in irrigated land under group B crop(s): fraction of irrigation and rain water stored in the root zone of B crop(s), average for all irrigations and rain storms (-), $0 < FsB < 1$
FsU#	Seasonal efficiency of rain water in non-irrigated land: fraction of rainwater stored in the root zone of non-irrigated lands as an average for all rain storms (-), $0 < FsU < 1$
Fw#	Seasonal fraction of pumped well water used for irrigation (-), $0 < Fw < 1$
Gu#	Subsurface drainage water used for irrigation in season # (m^3 /season per m^2 total polygonal area), $Gu\# < Gd$
Gw#	Ground water pumped from wells in the aquifer (m^3 /season per m^2 total polygonal area)
Hw	Initial water level in unconfined aquifers or initial hydraulic head in the rapidly permeable subsoil of semi-confined aquifers (m)
Hc	Initial water level in the slowly permeable top-layer of a semi-confined aquifer (m)
IaA#	Irrigation water applied to the irrigated fields under group A crop(s) in season # (m^3 /season per m^2 area under group A crops)
IaB#	Irrigation water applied to the irrigated fields under group B crop(s) in season # (m^3 /season per m^2 area under group B crops)
KcA	Key for group A crops: whether paddy (1) or not (0)
KcB	Key for group B crops: whether paddy (1) or not (0)
Kd	Key for the presence of a subsurface drainage system: yes -> $Kd = 1$, no -> $Kd = 0$
Kf	Key for farmers' responses to water logging, salinization or irrigation scarcity (yes -> $Kf = 1$, no -> $Kf = 0$)
Ki/e	Index for internal ($Ki/e=1$) or external ($Ki/e=2$) nodes
Khor	Horizontal hydraulic conductivity of an unconfined aquifer or of the rapidly permeable subsoil of a semi-confined aquifer (m/day)
Kver	Vertical hydraulic conductivity of the upper slowly permeable layer a semi-confined aquifer (m/day)
Ksc	Index for the presence of a semi-confined aquifer (-) yes -> $Ksc = 1$, no: $Ksc = 0$
Kr	Key for rotational type of agricultural land use (-). $Kr = 0, 1, 2, 3$ or 4. Possible land-use types are: irrigated land under group A crops, irrigated land under crops group B crops, and non-irrigated land (U); $Kr=0$ no rotation $Kr=4$ full rotation $Kr=1$ part or all of the non-irrigated land remains permanently as such, the remaining land is under full rotation $Kr=2$ part or all of the irrigated land under group A crop(s) remains permanently as such, the remaining land is under full rotation $Kr=3$ part or all of the irrigated land under group B crop(s) remains permanently as such, the remaining land is under full rotation
Kver	Vertical hydraulic conductivity of the slowly permeable topsoil of a semi-confined aquifer (m/day)

Lc#	Percolation from the irrigation canal system (m^3/season per m^2 total polygonal area)
Peq	Effective porosity (drainable or refillable pore space) of the aquifer (m/m), $0 < \text{Peq} < \text{Ptq}$
Per	Effective porosity (drainable or refillable pore space) of the root zone (m/m), $0 < \text{Per} < \text{Ptr}$
Pex	Effective porosity (drainable or refillable pore space) of the transition zone (m/m), $0 < \text{Pex} < \text{Ptx}$
Psq	Storativity of a semi-confined aquifer (-)
Ptq	Total pore space of the aquifer (m/m), $\text{Peq} < \text{Ptq} < 1$
Ptr	Total pore space of the root zone (m/m), $\text{Per} < \text{Ptr} < 1$
Ptx	Total pore space of transition zone (m/m), $\text{Pex} < \text{Ptx} < 1$
QH1#	Ratio of drain discharge and height of the water table above drain level (m/day per m)
QH2#	Ratio of drain discharge and squared height of the water table above drain level (m/day per m^2)
Qinf	Aquifer inflow condition (m^3/year per m^2 total area)
Qout	Aquifer outflow condition (m^3/year per m^2 total area)
Scale	Scale used in the definition of the nodal co-ordinates X and Y (-)
SL	Level of the soil surface (m)
SiU#	Surface inflow of water from surroundings into the non-irrigated area in season # (m^3/season per m^2 non-irrigated area)
SoA#	Outgoing surface runoff or surface drain water from irrigated land under group A crop(s) in season # (m^3/season per m^2 irrigated area under group A crops)
SoB#	Outgoing surface runoff or surface drain water from irrigated land under group B crop(s) in season # (m^3/season per m^2 irrigated area under group B crops)
SoU#	Outgoing surface runoff water from the non-irrigated area in season # (m^3/season per m^2 non-irrigated area)
Ts#	Duration of the season # (months)
X	Coordinate in x-direction as measured on the map of the nodal network (cm)
Y	Coordinate in y-direction as measured on the map of the nodal network (cm)

11 LIST OF SYMBOLS OF OUTPUT DATA

A	Seasonal fraction of the area under irrigated group A crop(s)
Ac	Fraction of the area permanently under irrigated group A crop(s) throughout the seasons (-)
B	Seasonal fraction of the area under irrigated group B crop(s)
Bc	Fraction of the area permanently under irrigated group B crop(s)
Cd	salt concentration of the drainage water at the end of the season (EC in dS/m)
Ch	Average salt concentration of the incoming ground water flow in the aquifer (dS/m)
Cqf	Salt concentration of the soil moisture in the aquifer, when saturated, at the end of the season (EC in dS/m)
CrA	Salt concentration of the soil moisture in the root zone, when saturated, of the permanently irrigated land under group A crop(s) at the end of the season (EC in dS/m), only used when the rotation key $K_r=0$ or $K_r=2$
CrB	Salt concentration of the soil moisture in the root zone, when saturated, of the permanently irrigated land under group B crop(s) at the end of the season (EC in dS/m), only used when the rotation key $K_r=0$ or $K_r=3$
CrU	Salt concentration of the soil moisture in the root zone, when saturated, of the permanently non-irrigated (U) land at the end of the season (EC in dS/m), only used when the rotation key $K_r=0$ or $K_r=1$
C1*	Salt concentration of soil moisture in the root zone, when saturated, of the land outside the permanently non-irrigated (U) area at the end of the season (EC in dS/m), only used when the rotation key $K_r=1$
C2*	Salt concentration of the soil moisture in the root zone, when saturated, of the land outside the permanently irrigated land under group A crop(s) at the end of the season (EC in dS/m), only used when the rotation key $K_r=2$
C3*	Salt concentration of the soil moisture in the root zone, when saturated, of the land outside the permanently irrigated land under group B crop(s) at the end of the season (dS/m), only used when the rotation key $K_r=3$
Cr4	Salt concentration of the soil moisture in the root zone, when saturated in the fully rotated land at the end of the season (EC in dS/m), only used when the rotation key $K_r=4$
Cxa	Salt concentration of the soil moisture in the transition zone aquifer above drain level, when saturated, at the end of the season (EC in dS/m), only used when the drainage key $K_d=1$
Cxb	Salt concentration of the soil moisture in the transition zone below drain level, when saturated, at the end of the season (EC in dS/m), only used when the drainage key $K_d=1$
Cxf	salt concentration of the soil moisture in the transition zone, when saturated, at the end of the season (EC in dS/m), only used when the drainage key $K_d=0$
Cw	salt concentration of the pumped well water at the end of the season (EC in dS/m)
Dw	depth of the water table below the soil surface at the end of the season (m)
EaU	Actual evapo-transpiration in the non-irrigated land (m^3 /season per m^2 non-irrigated area)
FfA	Field irrigation efficiency of group A crop(s) (-)
FfB	Field irrigation efficiency of group B crop(s) (-)
Fft	Total field irrigation efficiency (-)

Gd	Total amount of subsurface drainage water (m^3/season per m^2 total area), only used when the drainage key $K_d=1$
Ga	Subsurface drainage water originating from ground water flow above drain level (m^3/season per m^2 nodal area), only used when the drainage key $K_d=1$
Gz	Subsurface drainage water originating from ground water flow below drain level (m^3/season per m^2 nodal area), only used when the drainage key $K_d=1$
Gi	Amount of incoming ground water flow into a polygon (m^3/season per m^2 nodal area)
Go	Amount of outgoing ground water flow leaving a polygon (m^3/season per m^2 nodal area)
Gaq	Net horizontal flow in the aquifer (m^3/season per m^2 nodal area) $G_{aq} = G_{qi} + Q_{inf} - G_{qo} - Q_{out} - G_w$ (Q_{inf}/Q_{out} = inflow/outflow condition of the aquifer, G_w = pumping from wells). G_{aq} equals vertical flow from the aquifer into transition zone. In a semi confined aquifer it is the seepage flow.
Gqi	Horizontally incoming groundwater flow through the aquifer ($\text{m}^3/\text{season}/\text{m}^2$ nodal area)
Gqo	Horizontally outgoing groundwater flow through the aquifer ($\text{m}^3/\text{season}/\text{m}^2$ nodal area)
Gti	Horizontally incoming groundwater flow through the transition zone ($\text{m}^3/\text{season}/\text{m}^2$ nodal area)
Gto	Horizontally outgoing groundwater flow through the transition zone ($\text{m}^3/\text{season}/\text{m}^2$ nodal area)
Gnt	Net horizontal flow of ground water (m^3/season per m^2 nodal area). $G_{nt} = G_{aq} + G_{ti} - G_{to} - G_d$ (G_d = subsurface drainage)
Hw	Elevation of the water table at the end of the season (m) ⁵
IaA	Amount of field irrigation (m^3/season per m^2 irrigated land under group A crop(s))
IaB	Amount of field irrigation (m^3/season per m^2 irrigated land under group B crop(s))
Is	Net amount of irrigation water supplied by the canal system including the percolation losses from the canals, but excluding the use of drain and well water and the bypass (m^3/season per m^2 nodal area)
It	Total amount of irrigation water applied, including the percolation losses from the canals and the use of drainage and/or well water, but excluding the bypass (m^3/season per m^2 nodal area)
JsA	Irrigation sufficiency of group A crop(s) (-)
JsB	Irrigation sufficiency of group B crop(s) (-)
Kr	Key for rotational type of agricultural land use (-). $K_r = 0, 1, 2, 3$ or 4 . This value may be the same as that given with the input, or it may be changed by the program. Possible land-use types are: irrigated land under group A crops, irrigated land under crops group B crops, and non-irrigated land (U); $K_r=0$ no rotation $K_r=4$ full rotation $K_r=1$ part or all of the non-irrigated land remains permanently as such, the remaining land is under full rotation $K_r=2$ part or all of the irrigated land under group A crop(s) remains permanently as such, the remaining land is under full rotation $K_r=3$ part or all of the irrigated land under group B crop(s) remains permanently as such, the remaining land is under full rotation

LrA	Percolation from the root zone (m^3/season per m^2 irrigated area under group A crops)
LrB	Percolation from the root zone (m^3/season per m^2 irrigated area under group B crops)
LrU	Percolation from the root zone in the non-irrigated area (m^3/season per m^2 non-irrigated area)
LrT	Total percolation from the root zone (m^3/season per m^2 nodal area)
Qv	Net vertical recharge to the water table: $Qv = Lc + LrT - RrT$ (Lc = leakage from canals, LrT = percolation, RrT = capillary rise)
RrA	Capillary rise into the root zone (m^3/season per m^2 irrigated area under group A crop(s))
RrB	Capillary rise into the root zone (m^3/season per m^2 irrigated area under group B crop(s))
RrT	Total capillary rise into the root zone (m^3/season per m^2 nodal area)
RrU	Capillary rise into the root zone of the non-irrigated land (m^3/season per m^2 non-irrigated area)
Sto	Amount of water stored at the water table (m)
U	Seasonal fraction of the non-irrigated area (-)
Uc	Fraction of the permanently non-irrigated area throughout the seasons (-)
X	See list of input data
Y	See list of input data
Zs	Amount of salt stored in the surface reservoir, only applicable when the water table is above ground surface (m.dS/m)

12 EXERCISE ICMALD

12.1 Introduction

This exercise stems from the ILRI International Course on Micro Computer Applications in Land Drainage (ICMALD), given in The International Course on Land Drainage (ICLD).

The exercise is based on a fictitious and simplified situation. Three alternative situations are studied:

1. The depth of the water table in the different polygons under influence of the presence of a leaky irrigation canal from which water is lost by direct infiltration to the underground.
2. The depth of the water table when the canal is lined and infiltration losses are eliminated.
3. The depth of the water table when below the canal an interceptor drain is introduced instead of the canal lining.

Further it will be seen how the salt transport in the aquifer occurs, and some hand calculations will be made to check the output. These concern drain discharge, actual evapo-transpiration, capillary rise and ground-water flow.

12.2 Input

The input file prepared for the exercise has been given the name ICMALD. The input file ICMALD.INP is found in the subdirectory \SAHYSMOD\EXAMPLE

The nodal and polygonal network consists of rectangular polygons (see map of fig. 12.1). There are only unconfined aquifers. The figure also shows the hydraulic conductivity (K) along the sides between the polygons. It is seen that along the sides between the internal and external polygons, except the bottom one, the value of K equals zero, so that these sides form a flow boundary, and the ground-water flow is practically one-dimensional.

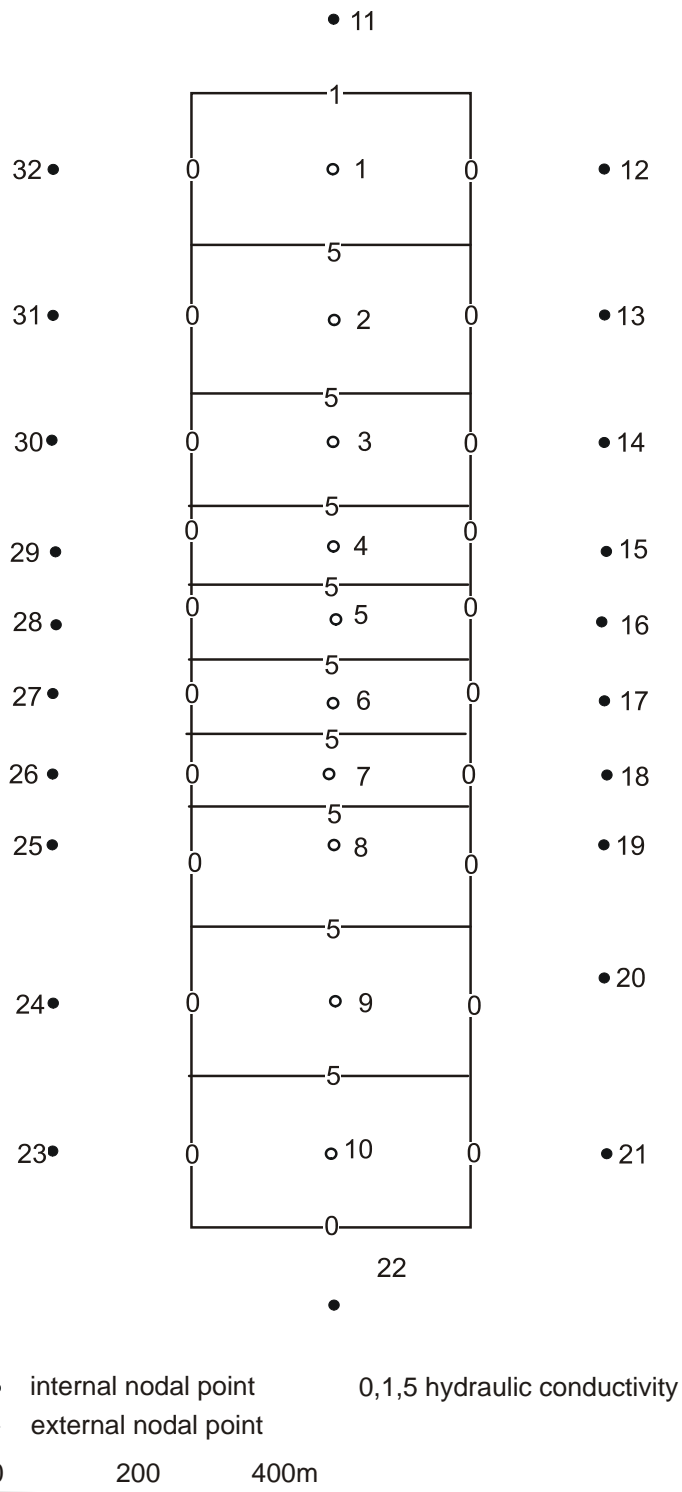

Figure 12.1 Nodal network relations exercise ICMALD

The data on nodal co-ordinates X and Y are found with the user menu using the option Open Input on the General Input tabsheet and then searching for the file: ICMALD in the directory SAHYSMOD\ICMALD (= path name), and thereafter using the Polygonal Input tabsheet and selecting Overall system geometry, finally clicking Go. The data on hydraulic conductivity (K) are found in the data group Hydraulic conductivity (also on the polygonal Input tabsheet).

Table 12.1 and the cross-section of fig. 12.2 show the distance Y between the polygons, to be found from the Y co-ordinates and the Scale, found in the on the General Input tabsheet. The elevations of the land surface (SL) and the bottom level (BL) of the aquifer in the internal nodes, respectively to be found in the data group 'Internal system properties' (see the Polygonal input tabsheet) and 'Overall system geometry', are also shown.

Table 12.1 System geometry

Polygon	Y (m)	SL (m)	BL (m)	Hw(0) (m)
1	200	200.0	100.0	195.0
2	400	196.0	96.0	191.5
3	600	192.0	92.0	188.0
4	700	190.0	90.0	186.5
5	800	188.0	88.0	185.0
6	900	186.0	86.0	182.0
7	1000	184.0	84.0	178.0
8	1100	182.5	82.5	174.0
9	1300	181.0	81.0	170.0
10	1500	179.0	79.0	166.0

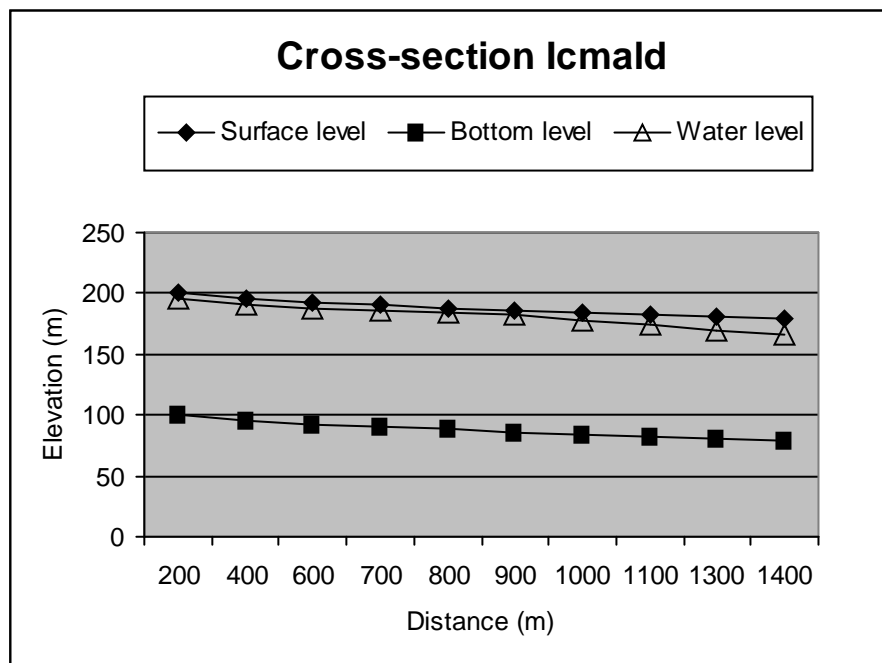

Figure 12.2 Cross-section over nodes 1 to 10 showing surface level, bottom level and height of the water table.

The values $H_w(0)$ of the initial height (hydraulic head) of the water table, found in the data group 'Initial hydraulic head' (on the Polygonal input tabsheet), have also been entered in the table and figure.

From the data group Inflow/outflow conditions it can be seen that in the internal polygon (no. 10) a constant outflow condition is given.

From the data group External boundary conditions in the Seasonal input tabsheet one can see that the external polygon no. 11 has a constant water-level condition, so that the inflow into polygon 1 is variable. In the data group External aquifer salinity (on the Polygonal input tabsheet) it can also be seen that the ground water inflow from polygon 11 is given a very high salinity of 50 dS/m, like seawater. This will just be used to demonstrate the transport of salt in the course of the time through the internal polygons.

In the data group Irrigation and field applications, on the Seasonal input tabsheet, it is found that in all polygons the percolation losses from the irrigation canals (L_c) are zero, except in polygon 5, where the value of L_c equals 1.20 m/season, only in the first of the two seasons. This simulates the presence of a large canal (right through the middle of the polygon) from which a considerable amount of water is leaking.

The polygons near the canal are narrower than farther away, to study the effect of the canal leakage more precisely.

From the nodal co-ordinates and the Scale factor one can calculate that the surface area of polygon 5 is 40000 m² (this figure will also show up in the output file). Since from the group Durations of the seasons (on the General Input or the Seasonal Input tabsheet) it is also found that the duration T_s of season 1 equals 6 months, the leakage from the canal can be recalculated as 3.09 l/s.

From the data group Irrigated area fractions (on the Seasonal Input tabsheet) it can be seen that irrigation is practiced only in season 1 while only group A crops are used (the B-fraction is zero). The A-fraction diminishes in the lowermost polygons. Also the field irrigation diminish. The reasons are explained later.

12.3 1st Inspection of the output

Make the first run with ICMALD clicking the Save all / Calculate button on the General input tabsheet. This produces the output file ICMALD.OUT. The program will do the calculations for 5 years continuously, as instructed in the General Input tabsheet. A warning is given that the irrigation in polygon 8 is reduced as the watertable rises to above the soil surface

When the output file is not visible, it can be inspected using the option Open Output on the Output tabsheet, following the same procedure as described above for the identification of the input file. One can then use for example the button Select Data for Graphs and then choosing the option Depth of the Water Table. Upon clicking the Go button, one may choose Polygonal data per season and hit Go. Next one may type 3 for the Year and 1 for the Season, choosing YEAR 3, SEASON 1. After again clicking Go, the depth of the water table in all the polygons can be seen under D_w . The values of D_w shown on the screen can be saved for spreadsheet use (e.g. under the name DW.PRN), by pressing Save Group. Hereafter a spreadsheet program can be used to import the DW.PRN file and to prepare the cross-section of D_w values from node 1 to node 10. The *.PRN file can also be used in mapping programs.

The depth of the water table is shown in table 12.2 under Reference Situation. The table shows that the water table comes close to the soil surface in polygon 8, while in polygons 7, 9 and 10 the depth of the water table is only between 0.4 and 0.7 m.

Table 12.2 Depth of water table (D_w , m) in Year 3, Season 1

Polygon no.	Reference situation	Canal lining	Interceptor drain
1	9.07	9.07	9.22
2	6.79	6.79	6.97
3	4.54	4.54	4.78
4	3.42	4.11	3.69
5	2.30	3.42	2.60
6	1.45	2.30	1.80
7	0.61	1.45	1.00
8	0.22	0.61	0.53
9	0.66	0.66	0.87
10	0.41	0.41	0.57

If you wish, you can see a graph of the water table clicking See Graph.

Returning to the Output tabsheet and using again Select Data for Graphs one can select Soil Salinities Rootzone one can also perceive that the soil salinity CrU in the non-irrigated land of polygon 10 in season 1 of year 3 reaches a relatively high value of 11.4 dS/m, and the salinity increases further in the following years. This can be found with Select Data for Graphs, the Soil Salinities Rootzone, then Time Data per Polygon, then Node 10. The soil salinity will be seen to fluctuate between seasons, but there is an increasing trend for CrU. In the irrigated land the salinity (C1*) is more stable.

Question: Why does the salinity increase in season 1 and decrease in season 2?

Using Frequency Distribution of Soil Salinity (after applying Select Data for Graphs) we see that, in season 1 of year 3, 20% of the non-irrigated area in this polygon (10) has a salinity CrU of more than 16.7 dS/m, because the cumulative frequency here is i.e. 80%, meaning the 80% of the non irrigated (U) land has a salinity less then 16.7 dS/m.

Further, inspection of data group Ground Water Flows learns that the net incoming groundwater flow Gnt in polygon 8, during season 1 of year 3, is 0.803 m, so that there can be no leaching (percolation) from the root zone. The capillary rise RrU in the non-irrigated land (see data group Capillary Rise into the Rootzone) amounts to 0.69 m/season (polygon 8). This explains the salt build-up in the non-irrigated land.

The irrigated land under group A crops during season 1 of year 3 (polygon 8) has a somewhat lower capillary rise (RrA=0.46 m/season) than in the non-irrigated land because the irrigation keeps the topsoil wet so that the capillarity is less than in the non-irrigated land with a dry topsoil.

Although the amount of irrigation water applied to the group A crops in polygon 8 (IaA=0.8 m/season, only in season 1) is less than the potential evapo-transpiration (EpA=1.0 m/season, see input), the irrigation sufficiency JsA of the crops is almost 100% (JsA=0.99, check this in the output), even in the absence of rainfall (Pp=0.0, see input), because the irrigation deficit is supplemented by the capillary rise from the shallow water table. Hence, also in the irrigated land of polygon 8, no leaching takes place (the percolation LrA is zero, check this in the output) and also here salt build-up occurs.

12.4 Canal lining

We have seen that polygon 5 contains a leaky canal. The effect of canal lining on the water table can be virtually simulated reducing the percolation losses from the leaky canal (L_c).

Using the input menu, the Seasonal Input tabsheet, and the category "Irrigation and Field Applications", we set $L_c=0$ for polygon 5, we do Save group, return to the General Input tab and save data file is saved as ICMALDc. The calculations can also be done.

Again, the D_w values of Year 3, Season 1, can be inspected and saved as a spreadsheet file (e.g. as DWc.PRN). Importing this file into the spreadsheet file made previously, the second series of D_w data can be incorporated. The output data of D_w are also entered in table 12.2, now under "Canal lining".

It can be seen that, compared with the situation under a leaky canal, the water table has descended somewhat, also in upstream direction (only in polygon 4) where the lowering of the water table is not really required. However, in polygon 8 the water table is still too shallow ($D_w = 0.66$ m, year 3 season 1) for normally productive agriculture, let alone to permit an increase of the irrigation for leaching and salinity control and an increase of irrigated area. The contribution of the percolation losses from the canal to the geo-hydrologic situation is apparently small compared to other forms of recharge to the aquifer, like the percolation losses from irrigation.

Of course, this conclusion is valid only under the input conditions given in ICMALD.

12.5 Interceptor drain

To study the effect of interception drainage along the canal, instead of canal lining, we will install in polygon 6, just downstream of polygon 5, in which the canal is situated, a drain at a depth $D_d=2.5$ m and with a capacity to drain $G_{db}= 0.01$ m³/d per m² total area when the drainage head H_d (i.e. the height of the water table above drain level) is 1 m. This gives a G_{db}/H_d ratio of $QH_1=0.01$ for drainage flow below drain level. The QH_2 ratio (G_{da}/H_d^2) is taken zero to indicate that the drainage above drain level is insignificant, hence the total drain discharge G_d will equal G_{db} . The chosen drainage capacity is relatively high.

The drain installation can be accomplished, through the input menu, by opening again the original ICMALD.INP file, by looking up the data group Indices of agricultural practices (under polygonal data) and changing the value of K_d (an indicator for the presence of a subsurface drainage system) under polygon 6 from 0 into 1. Further one looks into the data group Properties of the drainage system and gives the appropriate values to the depth D_d and the ratios QH_1 and QH_2 . The SahysMod program will prompt you to adjust some other data too, like C_{xa} , C_{xb} (both can be made equal to 1), F_{rd} (= 0 in both seasons), and G_u (zero in both seasons).

The canal leakage L_c in polygon 5 is maintained at its original value of 1.2 m/season.

Thereafter the data are saved, e.g. in a file named ICMALDd, and one proceeds with the calculations and the inspection of the output as described before. The results for D_w are found in table 12.2, under "Interceptor drain".

It can be seen that the effect of the interception drain is even less than that of the canal lining. The amount of water drained is apparently small compared to the other forms of recharge to the aquifer, like the percolation losses from field irrigation.

The above conclusions are of course valid only under the input conditions given in ICMALD.

Inspecting in the output the data group Drain and Well Discharge, it is found that the drain discharge G_d in year 3, season 1, equals 1.27 m/season or 2.3 l/s, a little less than the leakage from the canal ($L_c=3.1$ l/s).

12.6 Salt movement in the ground water

To appreciate the salt movement in the underground, one may inspect the ICMALD.OUT (reference situation) file using the symbol C_{qf} , in the data group Underground salinities, and option: Time Dat per Polygon data, choosing polygon 1. The button Show Symbols gives us the meaning of this symbol: salinity of the aquifer at the end of the season. The output option can be used repeatedly for polygons 2 and 3. The results are given in table 12.3

Table 12.3 Salinity (C_{qf} , dS/m) of the aquifer

Year	Season	Polygon		
		1	2	3
0	0	1.0	1.0	1.0
1	1	4.3	1.1	1.0
	2	7.8	1.5	1.0
2	1	10.7	2.1	1.1
	2	13.5	2.8	1.3
3	1	15.9	3.7	1.5
	2	18.2	4.7	1.7
Etc.				

The table shows that the aquifer in polygon 1 salinizes rapidly due to the incoming saline water from the external polygon 11. Polygon 2 salinizes also, but at a slower rate. Polygon 3 salinizes at the slowest pace.

Under such conditions it would not be advisable to use the ground water for irrigation, because the salinity wave will propagate through the whole aquifer, though it may take a long time before it reaches the lowermost polygons. However, abstraction of ground water will speed up the salinization. The Sahysmod model could be used to estimate the salinization of the ground water by introducing more pumping from wells, especially in the lowermost polygons and defining a re-use fraction.

12.7 Checking the drainage flow by hand

The drainage flow or drain discharge G_d (m/season) in polygon 6 for year 3, season 1, is calculated from eqn. 3.35a and previous equations as:

$$G_d = 30 QH1 (D_d - D_w) T_s =$$

$$30 \times 0.01 \times (2.5 - 1.8) \times 6 = 1.26 \text{ m/season}$$

This is practically the same as the computer calculation ($G_d = 1.27$ m/season) in sect. 12.5. The small difference is due to rounding of the D_w value.

12.8 Checking the capillary rise by hand

In polygons 7, 8, 9 and 10 we have defined an area fraction which is permanently non-irrigated as can be seen with the input menu where we find the irrigated area fractions A and B to be 0.5 or less. The reason is the shallow water table, which would become even more shallow when the irrigated area would be increased, even though the seasonal irrigation gift in the polygons ($IaA=0.8$ m/season) is less than in the other polygons ($IaA=1.2$ m/season or more).

The output data of the non-irrigated area can be recognized by the index U. In the U-area, capillary rise occurs from the ground water into the root zone (RrU , m/season) because the topsoil is dry. It is calculated from eqn. 3.29c as:

$$RrU = EaU - Pp - SiU + SoU$$

where: Pp is the rainfall (m/season) and EaU is the actual evapo-transpiration (m/season), SiU is the incoming surface runoff (m/season), and SoU is the surface drainage (m/season).

The rainfall is found from the input and, for season 1, amounts to 0.0 m. The values of SiU and SoU are also zero as can be seen in the input data (Seasonal Input tabsheet, Surface Inflow/Outflow option). The value of EaU in ICMALDd is found in the output under data group Evaporation from Unirrigated Land, and for polygon 9, year 3, season 1 it amounts to 0.565 m/season. Hence, the capillary rise RrU in the same polygon for year 3, season 1 should be equal to EaU as can be confirmed from the output file.

The total capillary rise (Rr) in the whole polygon 9 is smaller (0.33 m/season) than in the non-irrigated area alone, because the capillary rise RrA in the irrigated area fraction (50%) is only 0.08 m/season.

The evaporation EaU is found from eqn 3.26d and previous equations as:

$$EaU = FsU.Pp + Fc(EpU - FsU.Pp)$$

where: FsU is the storage efficiency (m/m) of the rainfall, indicating the fraction of the rain that is retained in the soil and does not percolate downward, EpU is the potential (i.e. maximum) evapo-transpiration (m/season) in the non-irrigated area, and Fc is a capillary rise factor ($0 < Fc < 1$) defined as:

$$Fc = 1 - (Dw - \frac{1}{2}Dr) / (Dc - \frac{1}{2}Dr)$$

where: Dc is the critical depth of the water table (m) for capillary rise, which can occur only if the water table is shallower than Dw , and Dr is the thickness of the root zone (m).

From the ICMALDd input file (drainage situation) we find in data group Internal System Properties (Polygonal Input tabsheet) that $Dr=0.8$ m. Further we find that $Pp=0.0$ m and $EpU=0.8$ m (option Rainfall and Crop Evaporation on the Seasonal Input tabsheet). On the same tabsheet in data group 'Storage/Irrigation Efficiency' we see that $FsU=0.9$ m/m, and in data group 'Critical Depth Capillary Rise' (Polygonal Input tabsheet) that $Dc=2.0$ m. The value of Dw is found in as 0.869 m. Hence:

$$Fc = 1 - (0.869 - 0.40) / (2.00 - 0.40) = 0.707$$

$$RrU = EaU = 0 + 0.707 \times (0.80 - 0) = 0.566 \text{ m/season}$$

This confirms the computer results ($EaU=0.565$ m/season).

12.9 Checking the ground water flow by hand

We will check the ground water inflow into and outflow from polygon 8 in the 1st season of the 3rd year using ICMALD.OUT (reference situation).

The incoming ground water flow $Gi_{7,8}$ from polygon 7 into polygon 8 is calculated with eqn. 4.28 and previous equations as:

$$Gi_{7,8} = 30Ts \cdot W_{7,8} (Hw_{7a} - Hw_{8a}) K_{7,8} D_{7,8} / Z_{7,8} Area_8 \quad \text{m/season}$$

where:

$W_{7,8}$ is the length of the side between the two polygons (m), Hw_{7a} and Hw_{8a} are the heights of the water table at the end of the season in the nodal points 7 and 8 respectively (m), $D_{7,8}$ is the seasonal time average of the average depth of flow between polygons 7 and 8, $K_{7,8}$ is the hydraulic conductivity along the side between the polygons 7 and 8 (m/day, see input), $Z_{7,8}$ is the distance between the nodal points 7 and 8 (m), and $Area_8$ is the surface area of polygon 8 (m², see output).

The values of Hw_{7a} and Hw_{8a} are found from

$$Hw_{7a} = SL_7 - Dw_7$$

$$Hw_{8a} = SL_8 - Dw_8$$

where SL_7 and SL_8 are the surface levels (m, see input), Dw_7 and Dw_8 are the seasonal average depths of the water table (m, see output) of the polygons 7 and 8 respectively.

The value of $D_{7,8}$ is determined from:

$$D_{7,8} = (D_7 + D_8) / 2,$$

where:

$$D_7 = Hw_{7a} - BL_7 = SL_7 - Dw_7 - BL_7$$

$$D_8 = Hw_{8a} - BL_8 = SL_8 - Dw_8 - BL_8$$

and:

BL_7 and BL_8 are the bottom levels of the aquifer in nodes 7 and 8 respectively (m, see input).

The outgoing ground water flow $Go_{8,9}$ from polygon 8 into polygon 9 is calculated with eqn. 4.29 and previous equations as:

$$Go_{8,9} = 30Ts \cdot W_{8,9} (Hw_{8a} - Hw_{9a}) K_{8,9} D_{8,9} / Z_{8,9} Area_8 \quad \text{m/season}$$

where additionally: $W_{8,9}$ is the length of the side between the two polygons (m), Hw_{9a} is the seasonal average height of the water table in the nodal point 9 (m), $D_{8,9}$ is the seasonal average of the average depth of flow between polygons 8 and 9, $K_{8,9}$ is the hydraulic conductivity along the side between the polygons 8 and 9 (m/day, see input), and $L_{8,9}$ is the distance between the nodal points 8 and 9 (m).

The value of Hw_{9a} is found from:

$$Hw_{9a} = SL_9 - Dw_9$$

where: SL_9 is the surface level (m, see input) and Dw_9 is the seasonal average depths of the water table (m, see output) of polygon 9.

The value of $D_{8,9}$ is determined from:

$$D_8 = (D_8 + D_9)/2,$$

where:

$$D_9 = Hw_{9a} - BL_9 = SL_9 - Dw_9 - BL_9$$

and:

BL_9 is the bottom level of the aquifer in node 9.

To assist with the calculations, tables 21.4 and 21.5 have been prepared on the basis of the X and Y co-ordinates of the nodal points, found in the input under data group Overall System Geometry (Polygonal Input tabsheet), the scale of the co-ordinates, found in the General Input, the relevant BL and SL data (Table 12.1), and the K values (see Hydraulic Conductivity group on the Polygonal Input tabsheet). Also the relevant depths of the water table Dw (see output data group Depth of the Water Table) for year 3, season 1, reference situation, are given. The values of W and Z are given in Table 12.5 together with some derived data.

Table 12.4 Geo-hydrological data per polygon
Scale 1 : 10000, Area polygon 8: 60000 m²

Poly- gon	X m	Y m	BL m	SL m	Dw m	Hwa=SL-Dw m	D=Hwa-BL m
7	400	1000	84.0	184.0	0.61	183.39	99.39
8	400	1100	82.5	182.5	0.22	182.28	99.28
9	400	1300	81.0	181.0	0.66	180.34	99.34

Table 12.5 Inter-polygonal geo-hydrological data
Scale 1 : 10000

Between polygons	W m	Z m	D' m	ΔH m	K m/day
7-8	400	100	99.34	1.11	5.0
8-9	400	200	99.31	1.94	5.0

D' is average of D between two neighboring polygons

ΔH is the difference between the Hwa values of the two polygons

Thus we obtain:

$$G_{i7,8} = \frac{30 \times 6 \times 400 \times 1.11 \times 5.0 \times 99.34}{100 \times 60000} = 6.61 \text{ m/season}$$

$$G_{o8,9} = \frac{30 \times 6 \times 400 \times 1.94 \times 5.0 \times 99.31}{200 \times 60000} = 5.78 \text{ m/season}$$

The above values check with the data in the output file (see data group Ground Water Flows in m/season): inflow in transition zone $G_{ti} = 0.358$, inflow in aquifer $G_{qi} = 6.25$, total inflow $G_i = G_{ti} + G_{qi} = 6.61$, outflow from transition zone $G_{to} = 0.313$, outflow from aquifer $G_{qo} = 5.49$, total outflow $G_o = G_{to} + G_{qo} = 5.80$. The small difference is due to a rounding off error and the fact that Sahysmod calculates the ground water flows day by day and then determines the seasonal average.

As the incoming flow (G_i) is more than outgoing (G_o) one can expect capillary rise and salinization at a shallow water table to occur.

For the above analysis, the data stored in the Groundwater Flows in m^3/season could also have been used.

13 CASE STUDY HANSI FARM

13.1 Introduction

The case study Hansi farm refers to a government farm of the state of Haryana, India. The farm is located along the road from New Delhi to Hissar. The region is semi-arid and the farm is intensively irrigated.

A sketch of the farm area with a nodal network is shown in fig. 13.1. A major irrigation canal cuts right across the farm. Near the canal, problems of water logging (shallow ground-water tables) are experienced.

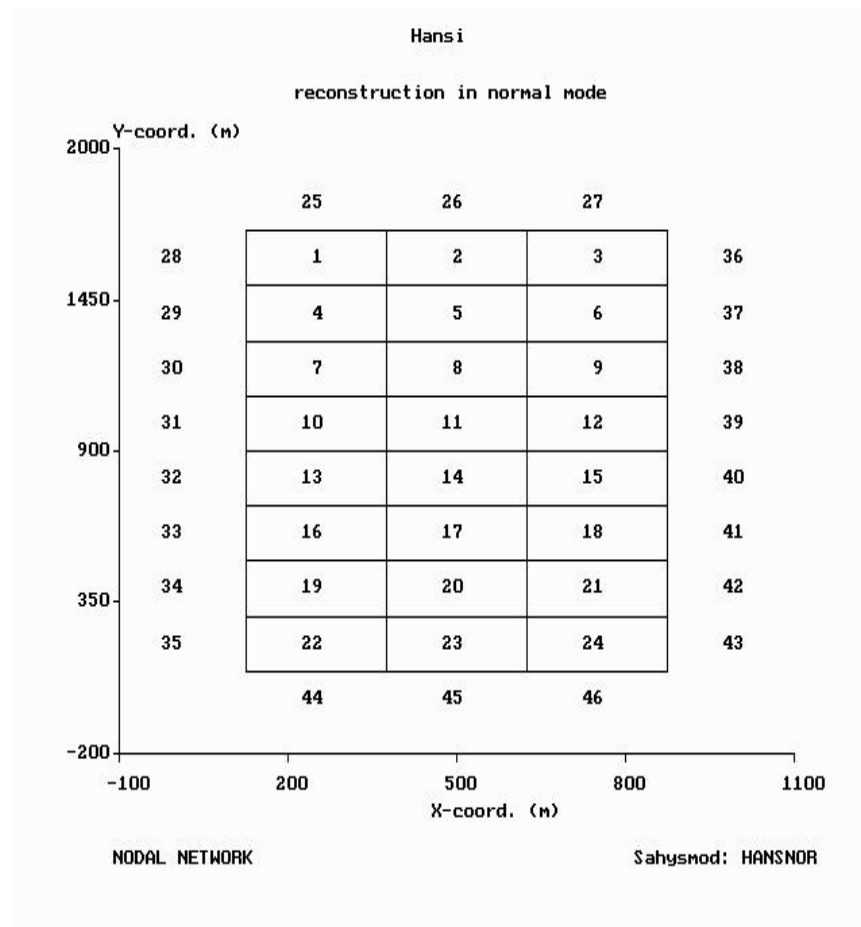

Figure 13.1 Nodal network over the Hansi farm with nodal blocks (polygonal rectangles) of 250 x 200 m. The irrigation canal bisects the farm.

The farm enjoys a certain privilege of use of the scarce irrigation water. This leads to extra deep percolation. Fig. 13.2 shows a ground-water mound resulting from the percolation. There exists a ground-water flow through an unconfined aquifer towards the neighboring lands, where the irrigation supply is limited. As the neighboring lands are dry, it is likely that the ground-water stemming from the farm is evaporated here through capillary rise. The neighboring lands are therefore subject to salinization.

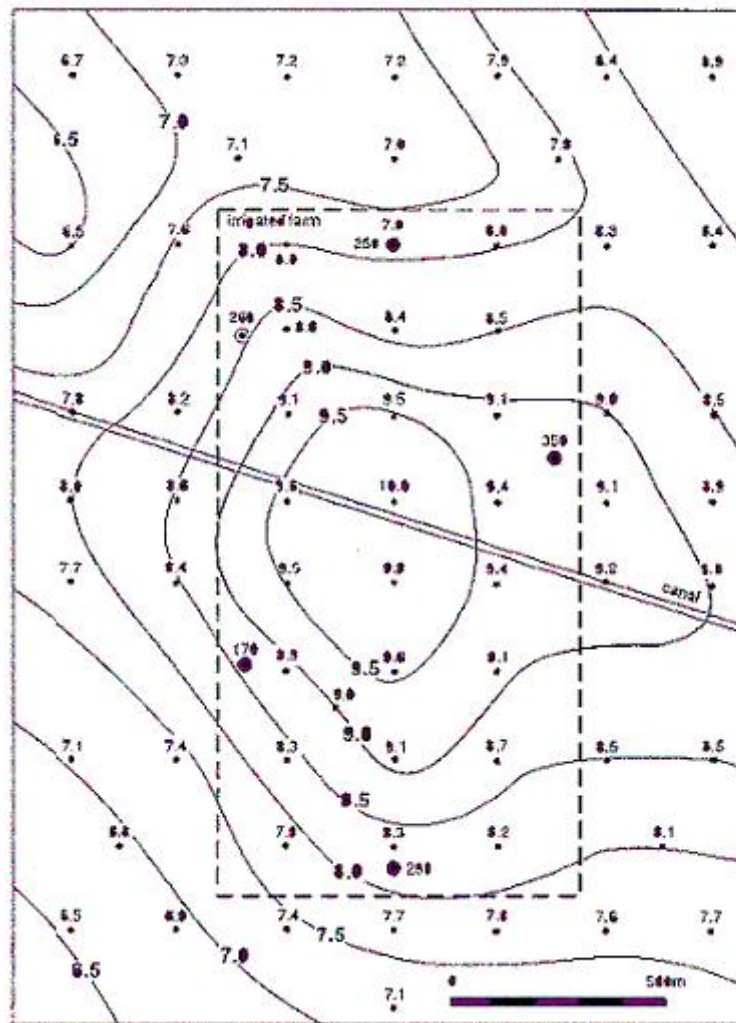

Figure 13.2 Contour map of the water table. Water table elevations are in m above sea level. The black circles give the places where pumping tests were made and the transmissivity values (KD) of the aquifer

A study was made of the possibility of establishing a subsurface drainage system in the water-logged areas with the aim to reduce the water logging problem and to reduce the water losses to the neighboring land.

Water-management data of the farm were scarce, but ground-water information was available. Fig. 13.2 shows five values of hydraulic transmissivity of the aquifer (i.e. the product of hydraulic conductivity, K , and depth, D) measured with pumping tests.

In the following the groundwater flows will be analysed assuming that the water levels and the depth of the water table remain constant.

13.2 Aquifer recharge

To calculate the aquifer recharge, only the geometry of the nodal network, the level of the water table, and the transmissivity needs to be given as input. All other data, like irrigation, evaporation, can be set equal to zero.

The transmissivity values were assigned to the nodal areas using the Thiessen polygon technique.

The bottom level of the aquifer was estimated at 100 m below the water level. Hence the conductivity can be found as 1% of the transmissivity.

The data are found in the file HANSIINV.INP in the subdirectory SAHYSMOD\HANSI.

When Sahysmod is run with HansiInv, it will give in year 0 the instantaneous ground water flow. This corresponds to the steady state ground water flow and recharge assuming that no fluctuations occur and that the observed ground-water situation is permanent. Under this assumption, the (steady state) net outflow of ground water (i.e. the outflow less the inflow) equals the (steady state) recharge. Since the recharge in HansiInv is zero, the assumption is not true, but later we will take care that the recharge is made equal to the net outflow so that the assumption will hold.

To find the output, activate SahysMod, open the input file HansiInv and click 'save all /calculate'.

The results of the polygonal (nodal) net outflow can be found using 'Select data for graphs', selecting 'Ground water flows in m/season', give 'Go', select 'Polygonal data per season', give 'Go', type '0' for Year and '1' for Season, and give 'Go' again.

In the last column, the table show the net groundwater inflow Gnt (= all inflows – all outflows). In the following table one finds the net groundwater outflow = - Gnt.

Table 13.1 Nodal net outflow in year 0

Node nr.	m/year	mm/day
1	1.10	3.1
2	0.45	1.3
3	-0.42	-1.1
4	1.38	3.8
5	-1.98	-5.5
6	-0.31	-0.9
7	0.67	1.9
8	2.80	7.8
9	0.33	0.9
10	1.98	5.5
11	3.24	9.0
12	0.46	1.3
13	1.65	4.6
14	1.12	3.1
15	0.57	1.6
16	0.05	0.2
17	2.54	7.1
18	0.05	0.2
19	-0.42	-1.2
20	2.62	7.3
21	-0.02	-0.1
22	0.44	1.2
23	0.26	0.7
24	-0.31	-0.9
Average	0.76	2.1

The table shows that the net outflow varies substantially in space and ranges from 9.0 mm/d in the middle of the farm to -1.1 mm/d in the fringes. In the latter areas there is a net inflow (= negative net outflow) that may cause capillary rise and salinization. The high negative value

in nodal area 5 is probably due to a measuring error of the water level. Fig. 13.1 reveals that the contour line of the water table has a counter curvature here.

The outflow values found (positive and negative) can be introduced in Sahysmod as recharge in different ways. For this study we use the inflow/outflow condition of the aquifer in each nodal area. This can be seen in the file HansiNor.inp, which equals HansiInv except that the recharge has been added as an inflow/outflow condition (see 'Aquifer inflow/outflow conditions' on the Polygonal Input tabsheet, after opening the HansiNor file). Positive values are found here in the Qinf column and the absolute value of the negative values are found in the Qout column. When Sahysmod is run for these conditions, i.e. with HansiNor, it will show a stable level of the water table, because the net inflow has been made equal to the net outflow calculated before.

Running HansiNor for 3 years and checking the depth of the water table (use the "select data" button, select the 'depth watertable' option, give Go, select 'Polygonal data per season, select any polygon nr of your choice (for example the central node 11), give 'Go' again and conclude that the water table is constant over the years.

13.3 Further investigations

This section still needs to be elaborated.