

Больница Шива в центре Израй

Крупнейшая клиника на Ближнем Востоке возле аэропорта и Средиземного моря



[home](#)

THE NAVAL BALANCE 1900

Navies of the world

01/01/1900



[Argentina](#)

[Australia](#)

[Austria-Hungary](#)

[Belgium](#)

[Brazil](#)

[Bulgaria](#)

[Cambodia](#)

[Chile](#)

[China](#)

[Colombia](#)

[Costa Rica](#)

[Cuba](#)

[Denmark](#)

[Dominican Republic](#)

[Ecuador](#)

[Egypt](#)

[El Salvador](#)

[France](#)



В этой игре жарко становится с первой минуты! >>>

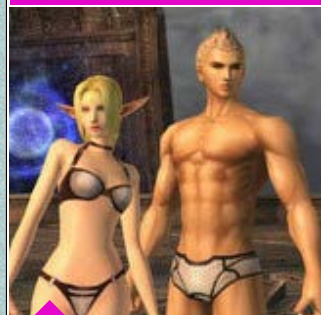

Сыграй в игру и ты не пожалеешь!

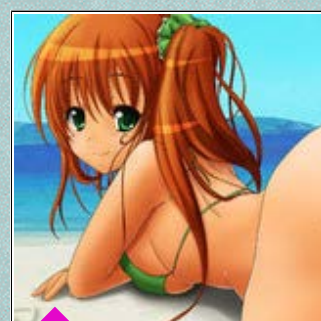

В этой игре жарко становится с первой минуты! >>>

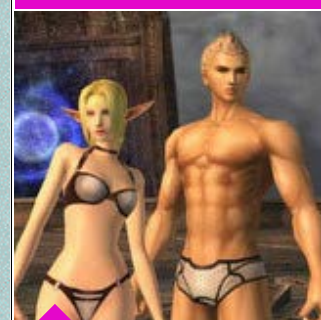

Сыграй в игру и ты не пожалеешь! Свобода в этой игре зашкаливает! >>>

Свобода в этой
игре зашкалив
ает! »»

[Germany](#)

[Greece](#)

[Haiti](#)

[Honduras](#)

[India](#)

[Italy](#)

[Japan](#)

[Mexico](#)

[Morocco](#)

[Netherlands](#)

[New Zealand](#)

[Norway](#)

[Ottoman Empire](#)

[Persia](#)

[Peru](#)

[Portugal](#)

[Romania](#)

[Russia](#)

[Sarawak](#)

[Siam](#)

[Spain](#)

[Sweden](#)

[United Kingdom](#)

[United States of America](#)

[Uruguay](#)

[Venezuela](#)

680668

[Website Hit Counter](#)

© Ivan Gogin, 2015

[home](#)[World navies yesterday](#)[1900](#)

Argentina 01 January 1900

BATTLESHIPS

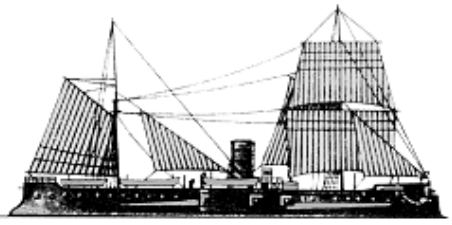
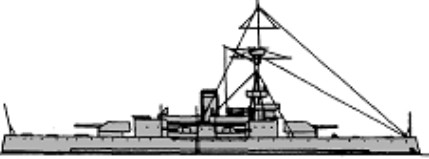

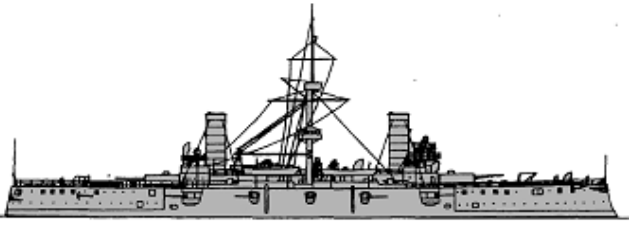
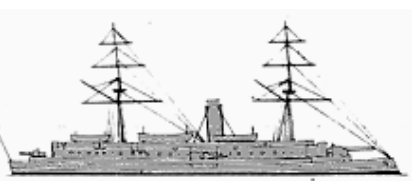

| | | | | | | | |
|----|-----------------|---------------|-----------|-----------------|--|--|---|
| BC | El Plata | 1 | El Plata | 1875 |  | 1500t, 56.7x13.4x3.2m, 4b,2vc, 750hp, 9.5kts, 126p; iron- 152belt, 30deck, 229turret; 1x2-203/30, 2x1-120/40, 2x1-57/40, 4x1-25/42 | |
| | | 2 | Los Andes | 1875 | | | |
| | Almirante Brown | 1 | 3 | Almirante Brown | 1882 |  | 4200t, 73.2ppx15.2x6.3m, 8b,2vc, 5400hp, 14kts, 520p; compound- 229belt, 203battery, 203CT; 10x1-150/50, 6x1-120/50, 2x1-47/40, 2-450TT |
| | Libertad | 4 | Libertad | 1892 |  | 2595t, 70.1ppx13.1x4.0m, 4b,2vte, 2780hp, 14.2kts, 230p; steel- 203belt, 37deck, 203barbettes, 102CT; 2x1-238/32, 4x1-120/41, 4x1-47/42, 2-450TT | |
| 5 | | Independencia | 1892 | | | | |

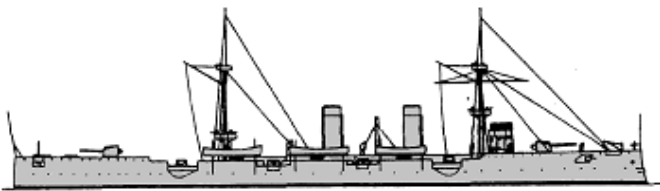
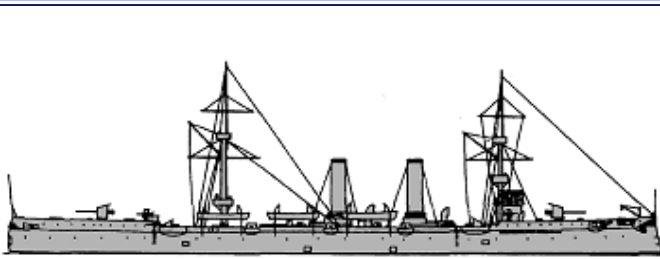
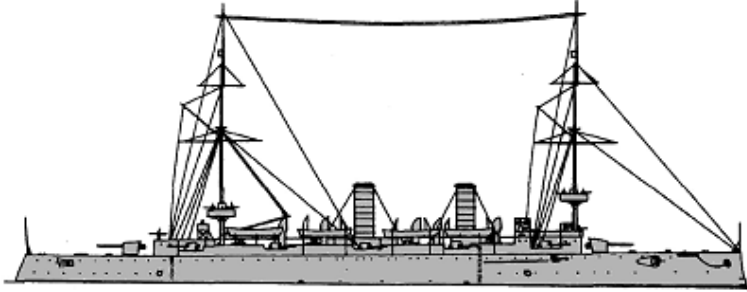
CRUISERS

| | | | | | | | |
|----|-----------|---|------------------|-----------|--|---|---|
| CA | Garibaldi | 1 | Garibaldi | 1896 |  | 6775t, 111.7x18.2x7.1m, 8b,2vte(1-3)-16b,2vte(4), 13000hp, 20kts, 500-540p; Harvey(1-3)-150belt, 150turrets, 37deck, 150CT; 2x1-254/40(1,3,4), 2x2-203/45(2), 10x1-152/40(1,2), 14x1-152/40(3,4), 6x1-120/41(1,2), 2x1-76/40(3,4), 10x1-57/40, 10x1-37/20(1,2), 12x1-37/20(3,4) | |
| | | 2 | San Martin | 1898 | | | |
| | | 3 | General Belgrano | 1898 | | | |
| | | 4 | Pueyrredon | 1898 | | | |
| | Patagonia | 1 | 1 | Patagonia | 1887 |  | 1530t, 64.9ppx10.0x3.9m, 2b,2hc, 2730hp, 14kts, 140p; steel- 102shield, 32deck, 38CT; 1x1-254/33, 3x1-152/31, 4x1-76/26 |
| | | | | | | | 3500t, 107.9x13.4x4.9m, |

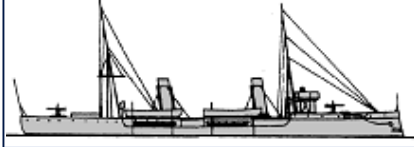

| | | | | | | | |
|----|---------------------|---|---|---------------------|------|--|---|
| CL | Veinticinco de Mayo | 1 | 2 | Veinticinco de Mayo | 1891 |  | 4b,2vte, 14050hp, 22.4kts, 320p; steel- 114slopes, 89deck, 51shields, 102CT; 1x1-209/32, 8x1-120/37, 12x1-47/37, (1+2x1)-450TT |
| | Nueve de Julio | 1 | 3 | Nueve de Julio | 1893 |  | 3600t, 113.5x13.4x5.0m, 8b,2vte, 14500hp, 22.2kts, 327p; steel- 114slopes, 89deck, 51shields, 102CT; 4x1-152/40, 8x1-120/41, 12x1-47/40, 5-450TT |
| | Buenos Aires | 1 | 4 | Buenos Aires | 1896 |  | 4788t, 129.2x12.9x5.6m, 8b,2vte, 17000hp, 24kts, 350p; steel- 127slopes, 38deck, 114shields, 152CT; 2x1-203/45, 4x1-152/45, 6x1-120/44, 16x1-47/40, 5-450TT |

TORPEDO SHIPS

| | | | | | | | |
|-----|------------|---|------|-------------------------------------|-----------|--|--|
| PGT | Maipú | 1 | 1 | Maipú | 1881 | No picture | 1063t, 82.4x9.2x2.7m, sw, 14kts, 90p; 1x1-121/21, 2-356TC |
| | Espora | 1 | 2 | Espora | 1890 |  | 520t, 64.0x7.6x2.5m, 4b,2vte, 3420hp, 19.4kts, 47p; 2x1-76/46, 1x1-63/42, 2x1-47/42, (1+2x2)-450TT |
| | Patria | 1 | 3 | Patria | 1894 |  | 1029t, 76.7x9.6x3.0m, 4b,2vte, 5000hp, 20.5kts, 100p; 2x1-120/41, 4x1-63/42, 2x1-47/42, 5-450TT |
| DD | Corrientes | 3 | 1 | Corrientes | 1898 |  | 280t, 57.9x5.9x2.2m, 6b,2vte, 4200hp, 27kts, 54p; 1x1-76/46, 3x1-57/42, (1+2x1)-450TT |
| | | | 2 | Entre Rios | 1896 | | |
| | | | 3 | Misiones | 1897 | | |
| TB | Ferré | 4 | 1-4 | Ferré, Enrique Py, Centella, Alerta | 1880-1882 |  | 52t, 30.5x3.8x1.8m, 1b,1vc, 500hp, 18.5-20kts, 11p; 2x4-25/42, 2-356TT |
| | Nr.1 | 2 | 5, 6 | Nr.1, 2 | 1881 | No picture | 17t, 18.4x2.3x1.1m, 1b,1vc, 230hp, 16kts, 10p; 1spar torpedo |
| | Nr.1 | 8 | 7-14 | Nr.1-8 | 1890 |  | 16t, 18.3x2.8x1.1m, 1b,1vte, 230-250hp, 17-18kts, 10p; 1x1-47/42, 1x1-356TT |
| | Bouchard | 6 | 15- | Bouchard, Bathurst, Jorge, | 1890- | | 90t, 39.6ppx4.3x1.8m, 2b,2vte(15,17-20)-2b,1vqe(16), 1110(15,17-20)-1230(16)hp, 23.5(15,17- |

| | | | | | | |
|-------------|---|----|----------------------|------|--|---|
| | | 20 | King, Pinedo, Thorne | 1892 |  | 20)-24.4(16)kts, 15p; 2x1-47/42, 1x4-25/42, (1+1x2)-450TT |
| Comodoro Py | 2 | 21 | Comodoro Py | 1892 | No picture | 110t, 45.7x4.4x1.1m, 2b,1vte, 1800hp, 25kts, 27p; 2x1-47/42, 1x4-25/42, (1+1x2+1x1)-450TT |
| | | 22 | Comodoro Murature | 1892 | | |

OTHER FIGHTING SHIPS

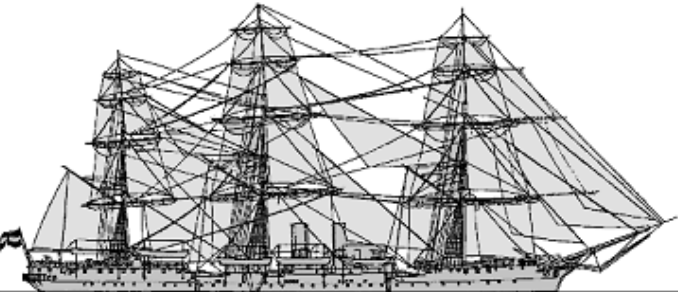
| | | | | | | |
|----|----------------------|---|----------------------|-----------|---|--|
| PG | Paraná | 1 | Paraná | 1874 |  | 515t, 46.3ppx7.6x3.0m, 2b,1hc, 475hp, 11kts, 100p; 2x1-120/41, 2x1-63/42 |
| | | 2 | Uruguay | 1874 | | |
| | Pilcomayo | 2 | 3 | República | 1876 |  |
| 4 | | | Constitución | 1876 | | |
| CT | Presidente Sarmiento | 1 | Presidente Sarmiento | 1898 |  | 2733t, 85.5ppx13.3x5.9m, 4b,2vc, 1800hp, 13kts, 305+40p, 4x1-120/43, 6x1-57/42, 2x1-37/27, 3-356TT |



[home](#)[World navies yesterday](#)[1900](#)

Australia 01 January 1900

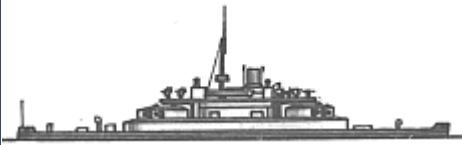
BATTLESHIPS

| | | | | | | | |
|-----|----------|---|---|----------|------|---|--|
| MON | Cerberus | 1 | 1 | Cerberus | 1870 |  | 3344t, 68.6ppx13.7x4.7m, 2hrcr, 1360(1)-1436(2)hp, 9.8(1)-10.7(2)kts, 155p; iron: 203belt, 38deck, 254turrets; 2x2-254/15MLR(1), 2x2-203/30(2) |
|-----|----------|---|---|----------|------|---|--|

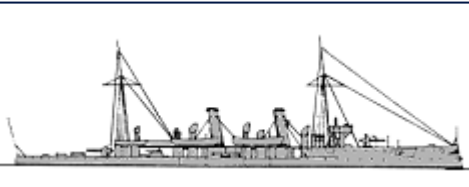
TORPEDO SHIPS

| | | | | | | | |
|-------|----------------------|---|-------|-----------------------------------|-------------|---|--|
| PGT | Sharpshooter | 1 | 1 | Boomerang | 1891 |  | 735t, 70.1ppx8.2x3.2m, 4b,2vte, 3600hp, 19kts, 91p; 2x1-120/40, 4x1-47/40, (1+2x2)-356TT |
| | | 2 | 2 | Karakatta | 1891 | | |
| TB | Childers | 1 | 1 | Childers | 1884 | No picture | 61t, 35.5x3.8x1.7m, 1b,1hce, 679hp, 18kts, 18p; 2x1-37/30, 2-381TT |
| | Countess of Hopetown | 1 | 2 | Countess of Hopetown | 1890 |  | 82t, 36.6x4.1xm, 1b,1vte, 1150hp, 23kts, 19p; 3x1-47/40, (2+1x1)-356TT |
| TB2cl | Gordon | 1 | 1 | Gordon | 1886 | No picture | 12t, 17.1x2.9x1.5m, 1b,1csce, 150hp, 15kts, 11p; 3x1-25/40, 2-356TC |
| | Midge | 1 | 2 | Midge | 1888 | No picture | 12t, 17.2x2.8x1.4m, 1b,1hce, hp, kts, p; 2x2-25/40, 1spar torpedo |
| | Acheron | 2 | 3, 4 | Acheron, Avernus | 1879 |  | 16t, 23.8x3.1x0.9m, 1b,1hce, 200hp, 15kts, 9p; 2-356TC |
| | Defender | 4 | 5 - 8 | Nepean, Lonsdale, No191, Mosquito | 1883 - 1884 | | 12t, 19.2ppx2.3x1.2m, 1b,1hce, 17kts, 7p; 1x2-25/40, 1-356TT |

OTHER FIGHTING SHIPS

| | | | | | | | |
|----|-----------|---|---|-----------|------|--|---|
| PG | Protector | 1 | 1 | Protector | 1884 | | 920t, 57.3x9.1x3.8m, 4b,2vce, 1500hp, 14kts, 90p; 1x1-203/26, 5x1-152/31, 4x1-47/40, 5x1-11.4 |
|----|-----------|---|---|-----------|------|--|---|

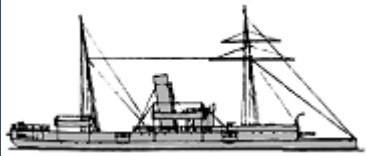
| | | | | | | |
|--------|---|---|----------|--|------------|--|
| | | | |  | | |
| Paluma | 2 | 2 | Paluma | 1884 | No picture | 360t, 36.6x7.9x2.9m, 1b,2vce, 400hp, 10.5kts, p; 1x1-203/26(54), 1x1-152/31, 2x1-37/30, 2x1-11.4 |
| | | 3 | Gayundah | 1884 | | |

Google™
Custom Search

© Ivan Gogin, 2014

[home](#)[World navies yesterday](#)[1900](#)



Austria-Hungary 01 January 1900

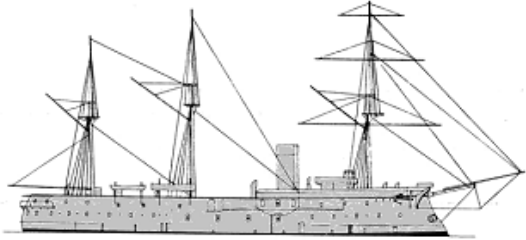
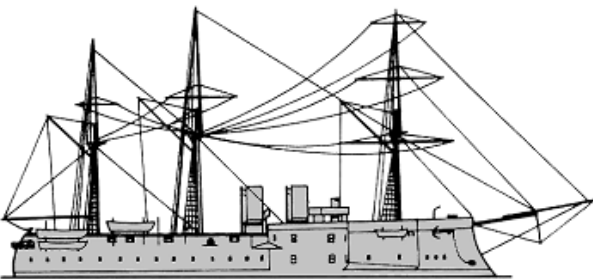
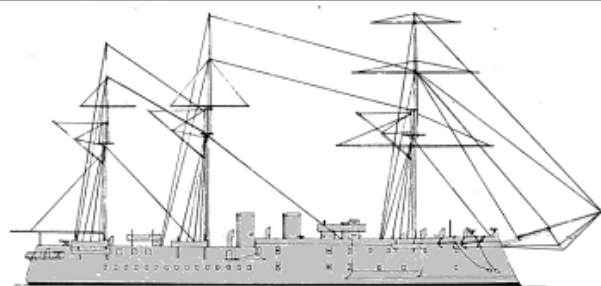
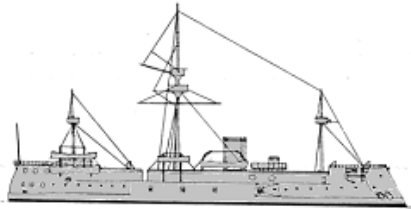
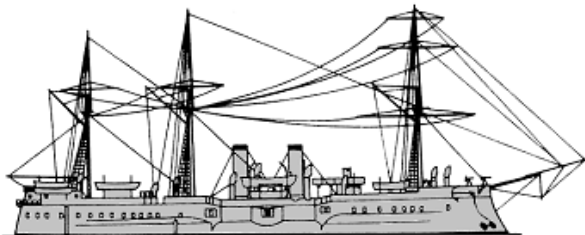
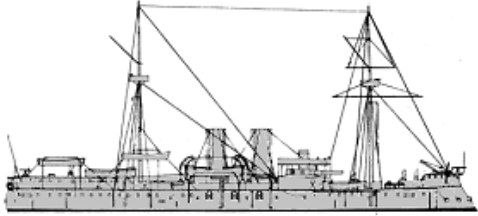

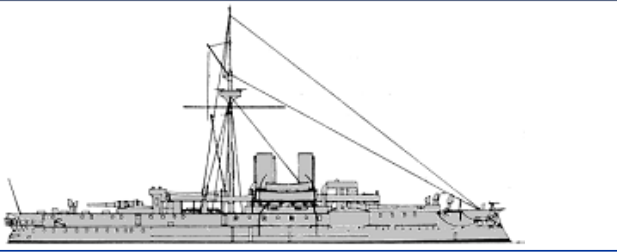
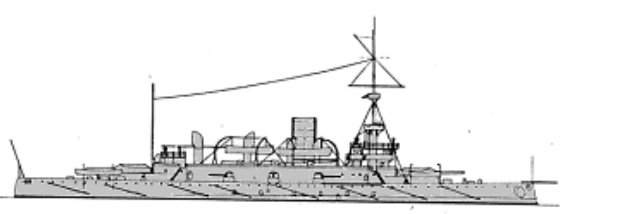
BATTLESHIPS

| | | | | | | |
|----|---|---|--------------------|------|--|---|
| | | | | |  | 5720t, 77.8x17.8x7.4m, 4b,2hr-cr, 2786hp, 11.5kts, 471p; iron- 152belt, 140casemates, 18deck; 10x1-229/15, 6x1-87/22, 2x1-66/16, 4x1-47/30, 3x5-47/22, 4x5-25/41, 3-356TT |
| | | | | |  | 5980t, 89.7x17.2x6.7m, 8b,1hr-cr, 3969hp, 12.8kts, 540p; iron- 205belt, 175casemates; 8x1-235/20, 6x1-87/22, 2x1-66/16, 4x1-47/30, 5x5-47/22, 2x5-25/41, 4-356TT |
| | | | | |  | 7731t, 95.0x17.7x7.9m, 8b,1hr-cr, 4158hp, 13.7kts, 548p; iron- 230belt, 175casemates; 8x1-263/20, 6x1-87/22, 2x1-66/16, 4x1-47/30, 5x5-47/22, 2x5-25/41, 4-356TT |
| BB | 3 | 4 | Kaiser Max | 1876 |  | 3548t, 75.9x15.3x6.2m, 4b,1hr-cr, 2755hp, 13.3kts, 400p; iron- 205belt, 125casemate; 8x1-209/18, 4x1-87/22, 2x1-66/16, 6x1-47/30, 3x5-47/22, 2x5-25/41, 4-356TT |
| | | 5 | Don Juan d'Austria | 1876 | | |
| | | 6 | Prinz Eugen | 1878 | | |
| | | | | |  | 7431t, 89.4x21.8x7.6m, 8b,2v-te, 8160hp, 15.3kts, 575p; iron- 370belt, 40deck, 370casemates, 175CT; 6x1-235/32, 5x1-149/33, 2x1-66/16, 9x1-47/40, 6x1-47/30, 2-356TT |
| | | | | |  | 5075t, 87.2x17.1x6.6m, 10b,2vc, 8000hp, 17kts, 430p; compound- 230belt, 25deck, 280turrets, 50CT; 2x1-305/32, 6x1-149/33, 2x1-66/16, 7x1-47/40, 2x1-47/30, 2x1-37/20, 4-400TT |
| | | | | | | 6829t, 97.6x19.3x7.4m, 10b,2vc, 6000hp, 15.5kts, |

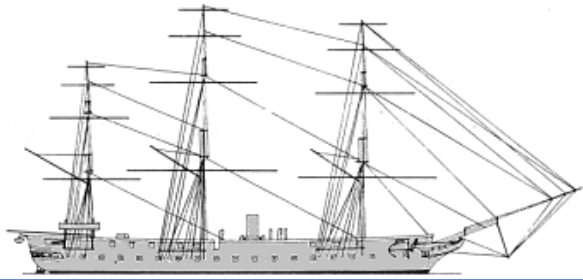
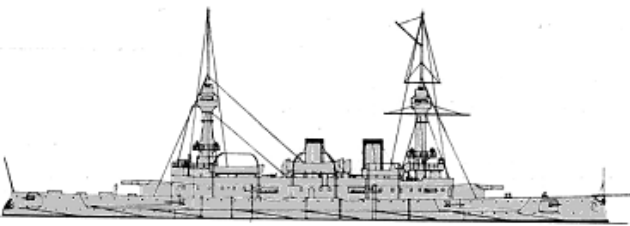
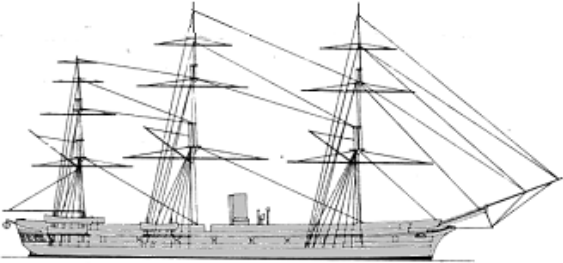
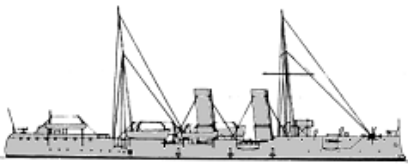

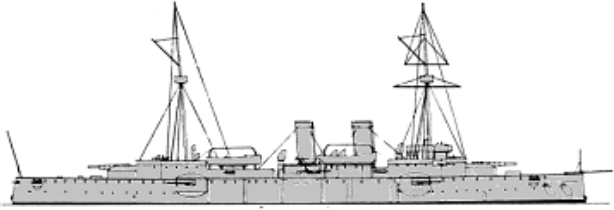
| | | | | | | |
|---------|---|----|----------|------|--|---|
| | | | | |  | 447p; Harvey- 305belt, 70deck, 250turrets, 75CT; 3x1-305/32, 6x1-120/31, 2x1-66/16, 5x1-47/40, 2x1-47/30, 2x1-37/20, 4-400TT |
| Monarch | 3 | 10 | Monarch | 1898 |  | 5645(10,12)-5636(11)t, 99.2x17.0x6.4m, 7b,2vte(10,11)-16b,2vte(12), 8500hp, 17.5kts, 426p; NS-270belt, 40deck, 250turrets, 250CT; 2x2-238/37, 6x1-149/37, 2x1-66/16, 10x1-47/40, 4x1-47/30, 2-450TT |
| | | 11 | Wien | 1898 | | |
| | | 12 | Budapest | 1898 | | |

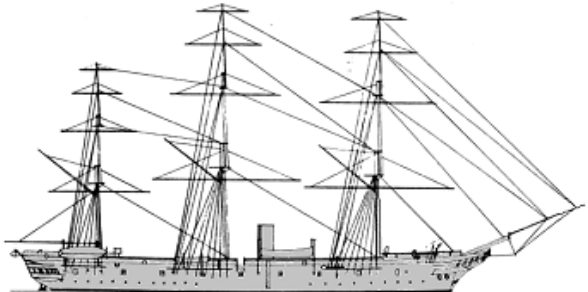
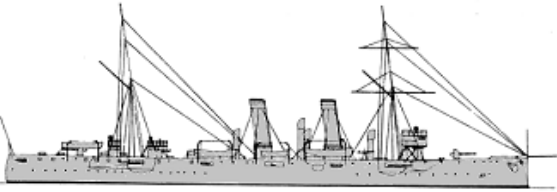





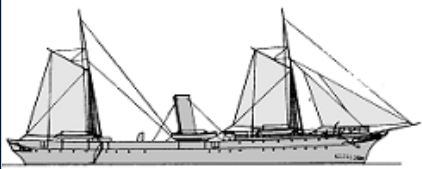
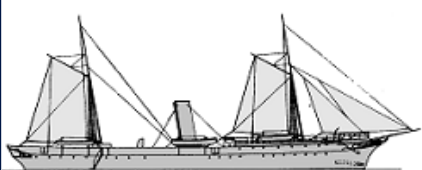
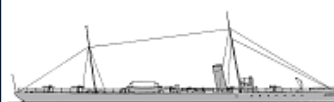

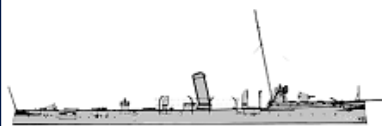

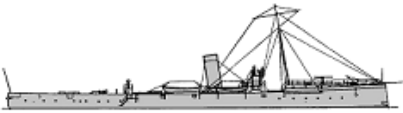

CRUISERS





| | | | | | | |
|----|-------------------------------------|---|-------------------------------------|------|--|--|
| CA | Radetzky | 1 | Radetzky | 1873 |  | 3956t, 79.1x14.3x7.0m, 4b,1hse, 3385(1)-2500(2)hp, 13.4(1)-13.2(2)kts, 450p; 15x1-149/24, 2x1-66/16, 4x1-47/30, 3x5-47/22, 3-356TT |
| | | 2 | Laudon | 1874 | | |
| | Kaiserin und Königin Maria Theresia | 1 | Kaiserin und Königin Maria Theresia | 1894 |  | 6026t, 113.7x16.3x6.8m, 10b,2hte, 9000hp, 19kts, 475p; Harvey- 100belt, 60deck, 100turrets, 50CT; 2x1-238/32, 8x1-149/33, 2x1-66/16, 12x1-47/40, 6x1-47/30, 4-450TT |
| | Saida | 1 | Saida | 1879 |  | 2662t, 79.4x13.1x5.8m, 4b,1hse, 1790hp, 12kts, 359p; 11x1-149/24, 1x1-66/16, 2x5-25/41 |
| | Panther | 2 | Panther | 1885 |  | 1557t, 73.2x10.4x4.3m, 6b,2vc, 5940(2)-6380(3)hp, 18.4(2)-18.7(3)kts, 186p; steel- 12deck; 2x1-120/31, 4x1-47/40, 6x5-47/22, 4-356TT |
| | | 3 | Leopard | 1886 | | |
| | Tiger | 1 | Tiger | 1888 |  | 1657t, 76.0x10.6x4.3m, 6b,2vc, 5700hp, 18.6kts, 188p; steel- 12deck; 4x1-120/31, 6x1-47/40, 4x5-47/22, 4-356TT |
| CL | Kaiser Franz Joseph I | 5 | Kaiser Franz Joseph I | 1890 |  | 4494t, 103.7x14.8x5.7m, 10b,2hte, 8450hp, 19kts, 367p; steel- 57hull, 38deck, 90barbettes, 50CT; 2x1-238/32, 6x1-149/33, 2x1-66/16, 5x1-47/40, 4x1-47/30, 3x1-37/20, 4-400TT |
| | | 6 | Kaiserin Elisabeth | 1892 | | |

| | | | | | | | |
|-----|--------|---|---|------------|------|--|--|
| | Donau | 1 | 7 | Donau | 1894 |  | 2306t, 70.0x12.8x5.6m, 4b,1vc, 1300hp, 10kts, 333p; 10x1-120/31, 1x1- 66/16, 4x5-25/41 |
| | Zenta | 1 | 8 | Zenta | 1899 |  | 2503t, 96.9x11.7x4.2m, 8b,2vte, 8160hp, 20.8kts, 308p; steel- 50slopes, 40deck, 35casemates, 50CT; 8x1-120/37, 8x1- 47/40, 2x1-47/30, 2-450TT |
| CLL | Zrinyi | 3 | 1 | Zrinyi | 1871 |  | 1353t, 69.1x10.5x5.0m, 2b,1hse, 1000(1,2)-1165(3)hp, 11(1,2)-11.2(3)kts, 210p; 2x1-149/18, 4x1-87/22, 2x1-66/16, 2x5-47/22 |
| | | | 2 | Fruntsberg | 1873 | | |
| | | | 3 | Aurora | 1874 | | |

TORPEDO SHIPS

| | | | | | | | |
|-----|----------|---|---|----------|------|--|--|
| PGT | Zara | 2 | 1 | Zara | 1881 |  | 852t, 67.2x8.2x3.7m, 5b,2vc, 2600hp, 14.3kts, 148p; 4x1-87/22, 1x1- 66/16, 4x1-47/30, 1x5-47/22, 2x5- 25/41, (2+2x1)-356TT |
| | | | 2 | Spalato | 1880 | | |
| | Sebenico | 1 | 3 | Sebenico | 1882 |  | 890t, 69.7x8.2x3.4m, 4b,2vc, 1344hp, 12.8kts, 135p; 4x1-87/22, 1x1- 66/16, 2x5-25/41, 1-356TT |
| | Blitz | 2 | 4 | Blitz | 1888 |  | 426t, 59.0ppx6.9x2.1m, 2b,1vte, 2600hp, 21kts, 61p; 8x1- 47/40, (1+1x1)-450TT(5) (1+1x1)-356TT(4) |
| | | | 5 | Komet | 1889 | | |
| | Meteor | 1 | 6 | Meteor | 1889 |  | 436t, 57.0ppx6.8x2.6m, 2b,1vte, 2600hp, 21kts, 60p; 9x1- 47/30, (1+1x1)-450TT |
| | Planet | 1 | 7 | Planet | 1890 |  | 525t, 67.1x7.0x2.8m, 4b,2vte, 3500hp, 19.6kts, 84p; 2x1-66/37, 8x1- 47/40, (1+1x1)-450TT |
| | Trabant | 1 | 8 | Trabant | 1890 |  | 540t, 67.0x8.0x2.4m, 4b,2vte, 3800hp, 20.1kts, 84p; 2x1-66/37, 8x1- 47/40, |



| | | | | | | | |
|----------|---------|-----------|-------------|--|--|---|---|
| | | | | | | | (1+1x1)-450TT |
| Satellit | 1 | 9 | Satellit | 1893 |  | 616t, 68.9x8.1x2.4m, 4b,2vte, 4000hp, 23kts, 86p; 1x1- 66/37, 6x1-47/40, (1+1x1)-450TT | |
| Magnet | 1 | 10 | Magnet | 1896 |  | 510t, 67.5ppx8.2x3.3m, 4b,2vte, 6000hp, 26kts, 80p; 6x1- 47/40, 2x1-450TT | |
| TB | I | 1 | I | 1875 |  | 10t, 20.7x2.6x1.2m, 1b,1vse, 184hp, 18kts, 9p; 1x1- 37/20 | |
| | II | 1 | II | 1878 |  | 28t, 26.5x3.5x1.6m, 1b,1hc, 300hp, 18.2kts, 10p; 2- 356TT | |
| | III | 2 | 3, 4 | III, IV | 1879 |  | 27t, 26.4x3.3x1.5m, 1b,1hc, 430hp, 17.5kts, 10p; 2- 356TT |
| | V | 4 | 5-8 | V-VIII | 1881 |  | 30t, 27.7x3.3x1.4m, 1b,1hc, 430hp, 18.3kts, 10p; 2- 356TT |
| | IX | 2 | 9, 10 | IX, X | 1881 |  | 47t, 31.2x3.7x1.6m, 1b,1vc, 500hp, 18kts, 15p; 1x1- 37/20, 2-356TT |
| | XI | 16 | 11- 26 | XI-XXVI | 1883- 1886 |  | 55t, 34.3x3.8x1.7m, 1b,1vc, 600hp, 18-19kts, 16p; 1x1-37/20, 2- 356TT |
| | Adler | 2 | 27 | Adler | 1886 |  | 100t, 41.2x4.2x1.7m, 2b,1vc, 1300hp, 22kts, 16p; 2x1- 37/20, 2-356TT |
| | | | 28 | Falke | 1886 | | |
| | Sperber | 2 | 29, 30 | Sperber, Habicht | 1886 |  | 93t, 39.9x4.8x1.9m, 1b,1vte, 970hp, 18.5kts, 16p; 2x1-37/20, 2- 356TT |
| | Bussard | 20 | 31- 50 | Bussard, Condor, Geier, Uhu, Würger, Kranich, Reiher, Ibis, Rabe, Elster, Kukuk, Staar, Krähe, Flamingo, Sekretär, Weihe, Marabu, Gaukler, Harpie, Kibitz | 1886- 1891 |  | 88t, 39.9x4.8x1.9m, 1b,1vte, 1000hp, 19kts, 16p; 2x1- 37/20, (1+1x1)-356TT |
| XXVII | 6 | 51- 56 | XXVII-XXXII | 1886- 1888 |  | 55t, 34.3x3.8x1.7m, 1b,1vc, 600hp, 18-19kts, 16p; 1x1-37/20, 2- 356TT | |
| XXXIII | 1 | 57 | XXXIII | 1887 |  | 70t, 36.8x4.5x1.9m, 1b,1vc, 700hp, 17kts, 16p; 2x1- | |

| | | | | | | | |
|--------|---|-------|-------------|-----------|--|--|--|
| | | | | | | | 37/20, 2-356TT |
| XXXIV | 6 | 58-63 | XXXIV-XXXIX | 1889-1891 |  | | 64t, 36.9x4.8x1.9m, 1b,1vc, 750hp, 20.3kts, 16p; 2x1-37/20, (1+1x1)-356TT |
| Natter | 1 | 64 | Natter | 1896 |  | | 166t, 47.3x5.3x2.8m, 2b,1vte, 2200hp, 24kts, 21p; 2x1-47/30, 3x1-450TT |
| Viper | 1 | 65 | Viper | 1896 |  | | 124t, 45.0x4.5x2.3m, 2b,1vte, 1900hp, 25kts, 21p; 2x1-47/30, 3x1-450TT |
| Boa | 3 | 66 | Boa | 1898 |  | | 132t, 46.6x4.7x2.3m, 2b,1vte, 2000hp, 24.5kts, 21p; 2x1-47/30, 3x1-450TT |
| | | 67 | Cobra | 1898 | | | |
| | | 68 | Python | 1899 | | | |

ESCORTS

| | | | | | | | |
|----|---|---|---|--------|------|--|------|
| AY | - | 1 | 1 | Dalmat | 1896 | | 260t |
|----|---|---|---|--------|------|--|------|

OTHER FIGHTING SHIPS

| | | | | | | | |
|------|----------|---|----------|----------|------|---|--|
| PG | Möwe | 1 | 1 | Möwe | 1859 | No picture | 348t, 45.0x7.2x3.2m, sails, 48p; 2x1-160/14 |
| | Kerka | 1 | 2 | Kerka | 1861 | No picture | 540t, 45.0x8.0x3.6m, 1hse, 250hp, 9kts, 100p; 4x1-160/14, 2x1-149/14 |
| | Dalmat | 1 | 3 | Hum | 1861 | No picture | 869t, 53.0x8.7x3.7m, 1hse, 230hp, 11.5kts, 139p; 2x1-194/14, 2x1-149/14 |
| | Albatros | 2 | 4 | Albatros | 1874 | No picture | 570t, 46.0x8.3x3.4m, 400hp, 10kts, 99p; 2x1-149/24, 1x1-83/17 |
| | | 5 | Nautilus | 1874 | | | |
| RMON | Leitha | 2 | 1 | Leitha | 1872 |  | 315t, 50.6x8.1x1.1m, 2b,2vte, 700hp, 8kts, 59p; steel- 44side, 25deck, 50CT; 1x1-120/33, 2x1-47/40 |
| | | | 2 | Maros | 1872 | | |
| | Körös | 2 | 3 | Körös | 1892 |  | 448t, 54.0x9.0x1.2m, 2b,2vte, 1200hp, 10kts, 72p; 50side, 19deck, 75(3)-50(4)CT; 2x1-120/31, 2x1-66/37 |
| | | | 4 | Szamos | 1892 | | |

COASTAL FORCES

| | | | | | | | |
|-----|---|---|---|---|------|------------|---------------------------|
| YPR | A | 1 | 1 | A | 1895 | No picture | 33t, 22.0x3.5x1.1m, 200hp |
|-----|---|---|---|---|------|------------|---------------------------|

MINE WARFARE SHIPS

| | | | | | | | |
|----|------------|---|---|------------|------|------------|---|
| ML | Dromedar | 1 | 1 | Dromedar | 1891 | No picture | 175t, 32.0x5.4x1.9m, 1b,1vte, 350hp, 10kts, 25p; 2x1-47/30, 50mines |
| | Salamander | 1 | 2 | Salamander | 1892 | No picture | 286t, 39.6x8.1x1.5m, 1b,1vte, 350hp, 10kts, 28p; 2x1-47/30, 90mines |

[home](#)

[World navies yesterday](#)

[1900](#)

Belgium 01 January 1900

ESCORTS

| | | | | | | | |
|-----|----------------|---|---|----------------|------|------------|--------------------------|
| FPV | Ville d'Anvers | 1 | 1 | Ville d'Anvers | 1886 | No picture | 684t, 65.2x9.1x3.6m, 45p |
|-----|----------------|---|---|----------------|------|------------|--------------------------|

© Ivan Gogin, 2015

[home](#)[World navies yesterday](#)[1900](#)

Brazil 01 January 1900

BATTLESHIPS

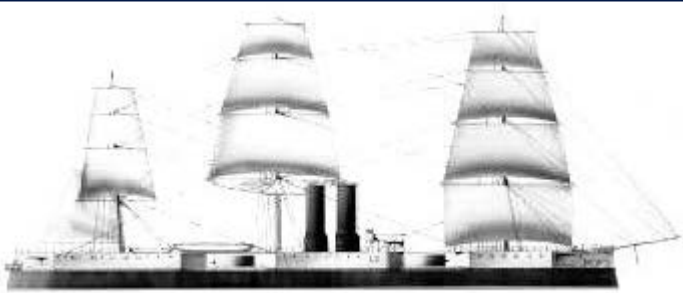
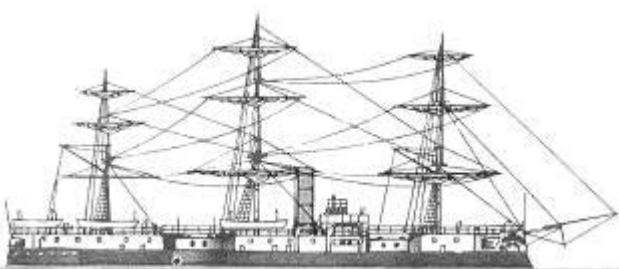

| | | | | | | | |
|----|-----------|---|---|------------------------|------|---|---|
| BB | Riachuelo | 1 | 1 | Riachuelo | 1883 |  | 6100t, 93.0ppx15.9x6.0m, 10b,2vc, 7300hp, 16.7kts, 367p; compound- 292belt, 254turrets, 254CT; 2x2-234/31, 6x1- 120/32, 6x1-47/40, 5- 356TT |
| | Aquidabã | 1 | 2 | Vinte e Quatro de Maio | 1887 |  | 4921t, 85.3x15.9x5.6m, 8b,2ic, 6500hp, 15.8kts, 277p; compound- 292belt, 254turrets, 254CT; 2x2-234/31, 4x1 - 120/40, 10x1-57/42, 5-356TT |

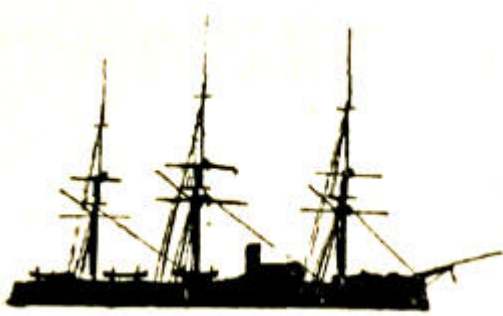
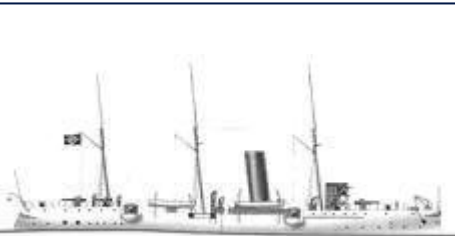
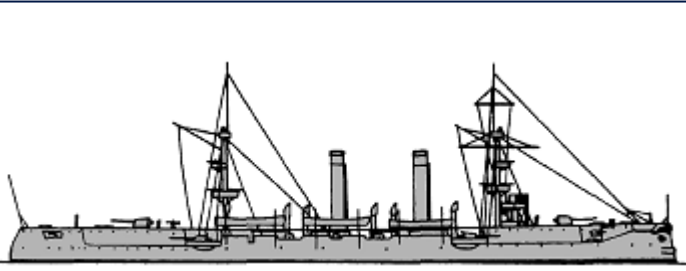

CRUISERS

| | | | | | | | |
|----|---------------------|---|---|---------------------|------|--|--|
| CL | Niterói | 1 | 1 | Niterói | 1864 | No picture | 1790t, 58.4x12.6x5.4m, 1hse, 1000hp, 7kts, 271p; 12x1- 127/24 |
| | Guanabara | 1 | 2 | Paysandú | 1879 | No picture | 1914t, 61.0ppx12.6x5.4m, 1hse, 3000hp, 13kts, 287p; 9x1- 127/24, 2x1- 76/23, 1 spar torpedo |
| | Almirante Tamandaré | 1 | 3 | Almirante Tamandaré | 1893 |  | 4735t, 89.7x14.4x6.0m, 7b,2hte, 7500hp, 17kts, 400p; steel- 40deck, 76casemates, 51CT; 10x1- 152/40, 2x1- 120/40, 10x1- 47/40 |
| | | | | | | | 2820t, 74.0x13.6x5.6m, 2vte, 4000hp, |

| | | | | | | | |
|-----|-------------------|---|---|-------------------|------|--|---|
| | Benjamin Constant | 1 | 4 | Benjamin Constant | 1894 |  | 15kts, 216+184p; 51deck, 95CT; 4x1-152/40, 8x1-120/40, 2x1-76/40, 2x1-37/20, 2x5-37/17, 4-450TT |
| | República | 1 | 5 | República | 1894 |  | 1300t, 64.0ppx10.7x3.9m, 2hte, 3800hp, 17.4kts, 160p; steel- 51slopes, 25deck; 6x1-120/40, 4x1-57/40, (1+2x1)-356TT |
| | Almirante Barroso | 1 | 6 | Almirante Barroso | 1897 |  | 3437t, 108.0x13.3x5.2m, 4b,2vte, 7500hp, 20.2kts, 366p; 88slopes, 31deck, 102CT; 6x1-152/50, 4x1-120/50, 10x1-57/40, 4x1-37/20, 3-450TT |
| CLL | Trajano | 1 | 1 | Tonelero | 1873 | No picture | 1392t, 61.0ppx10.5x4.7m, 1hc, 2400hp, 11kts, 206p; 6x1-127/24 |
| | Parnaíba | 1 | 2 | Parnaíba | 1878 | No picture | 742t, 52.5ppx8.9x3.5m, 1hse, 900hp, 11.5kts, 149p; 6x1-127/24 |
| | Primeiro de Março | 1 | 3 | Primeiro de Março | 1881 | No picture | 750t, 50.8ppx8.4x3.5m, 1hc, 750hp, 8.5kts, 142p; 7x1-127/24 |

TORPEDO SHIPS

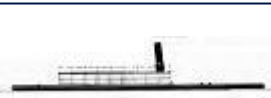
| | | | | | | | |
|-----|-----------------|---|---|-----------------|------|--|--|
| PGT | Tiradentes | 1 | 1 | Tiradentes | 1893 |  | 795t, 50.3ppx9.1x3.3m, 2vte, 1646hp, 14.5kts, 110p; steel-25CT; 4x1-120/40, 3x1-57/40, 2x1-356TT |
| | Gustavo Sampaio | 1 | 2 | Gustavo Sampaio | 1893 |  | 480t, 60.0ppx6.1x2.6m, 2vte, 2000hp, 18kts, 60p; steel-19CT; 2x1-89/40, 4x1-47/40, (1+2x1)-356TT |
| | Tupi | 2 | 3 | Tupi | 1897 | | 1014t, 76.1x9.4x3.1m, 2vte, 7000hp, 22.5kts, 110p; steel-13deck, 114shields, 25CT; 2x1-120/37, 6x1-57/37, 2x1- |
| | | 4 | 4 | Timbira | 1897 | | |

| | | | | | | | |
|-------|--------------|----|---------------|--------------------|---|---|---|
| | | | | | |  | 37/37, (1+2x1)-356TT |
| | Núm.1 | 5 | 1-5 | Núm.1-5 | 1882 | No picture | 40(1)-52(2-5)t, 30.5(1)-33.5(2-5)x3.8x1.7m, 1b,1vc, 500hp, 20(1)-20.4(2-5)kts; 1x1-37/20, 2-356TT |
| | Tamborim | 1 | 6 | Tamborim | 1884 | No picture | 16t, 19.2x2.4x0.9m, 1b,1vc, 60hp, 18kts; 1spar torpedo |
| | Sabino Voera | 1 | 7 | Sabino Voera | 1884 | No picture | 13t, 19.2ppx2.3x1.0m, 1b,1vc, 17kts; 2-356TT |
| | Alpha | 3 | 8-10 | Alpha, Beta, Gamma | 1885-1886 | No picture | 4t, 13.7x1.8x0.4m, 1b,1vse, 12.3kts; 1spar torpedo |
| | Piratini | 1 | 11 | Piratini | 1879 |  | 165/259t, 39.6x5.2x2.7/3.4m, 1b,1vse, 1000hp, 15/10kts; iron- 406breastwork; 2x1-37/20, 1-340 TT |
| TB | Araguari | 4 | 12 | Araguari | 1893 | No picture | 110t, 45.7x4.4x1.1m, 2b,1vte, 1800hp, 25kts, 27p; 2x1-47/42, (1+2x1)-381TT |
| | | | 13 | Bento Gonçalves | 1893 | | |
| | | | 14 | Marcílio Dias | 1893 | | |
| | | | 15 | Iguatemi | 1893 | | |
| Panne | 5 | 16 | Panne | 1892 |  | 130t, 46.3x5.3x2.4m, 2b,2vte, 2200hp, 26kts, 24p; 2x1-37/37, (1+2x1)-356TT | |
| | | 17 | Pedro Affonso | 1892 | | | |
| | | 18 | Pedro Ivo | 1892 | | | |
| | | 19 | Pernambuco | 1892 | | | |
| | | 20 | Silvado | 1892 | | | |
| | Moxotó | 1 | 21 | Moxotó | 1893 | No picture | 17t, 18.3x2.8x1.2m, 1b,1vc, 230hp, 16kts; 2x1-37/20, 1-340TT |
| | Potí | 1 | 22 | Potí | 1893 | No picture | 30t, 38.4x3.7x0.9m, 18kts; 1x1-37/20, 1-340TT |
| | Inhandua | 1 | 23 | Inhandua | 1893 | No picture | 17t, 19.3x3.0x0.9m, 23kts; 1x1-37/20, 1-340TT |

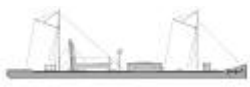

OTHER FIGHTING SHIPS

| | | | | | | | |
|------|--------------|---|------|---------------|------|---|---|
| RMON | Pará | 2 | 1 | Rio Grande | 1867 |  | 490t, 39.0x8.5x1.5m, 2b,2hda, 180hp, 8kts, 43p; iron- 102belt, 13deck, 152turret; 1x1-163/23 or 1x1-127/24 |
| | | | 2 | Alagoas | 1867 | | |
| PG | Afonso Celso | 1 | 1 | Trindade | 1883 | No picture | 327t, 30.8x6.7x2.8m, 1vc, 120hp, 13kts; 2x1-76/23, 1x1-25/42 |
| PGR | Yutohy | 2 | 1, 2 | Yutohy, Teffé | 1892 | No picture | 33t, 27.4ppx4.6x1.5m, 11kts; 1x1-47/40 |

[home](#)[World navies yesterday](#)[1900](#)

Bulgaria 01 January 1900

TORPEDO SHIPS

| | | | | | | | |
|-----|--------------|---|------|-----------------------------|-----------|--|---|
| PGT | Nadezhda | 1 | 1 | Nadezhda | 1898 |  | 715t, 67.0x8.3x3.1m, 4b,2vte, 2600hp, 18kts, 97p; 2x1-100/45, 2x1-65/50, 2x1-47/40, 2x1-381TT |
| TB | Vasil Levski | 2 | 1, 2 | Vasil Levski, Khristo Botev | 1877-1878 |  | 20t, 18.3x2.3x1.1m, 1b,1vc, 220hp, 13kts, 9p; 2spar torpedoes |

© Ivan Gogin, 2015

[home](#)

[World navies yesterday](#)

[1900](#)

Cambodia 01 January 1900

OTHER FIGHTING SHIPS

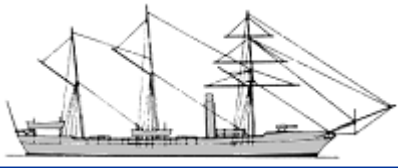

| | | | | | | | |
|----|-------|---|---|-------|------|---|---|
| PG | Lutin | 1 | 1 | Lutin | 1877 |  | 492t, 44.1x7.3x3.3m, 2b,1hc, 440hp, 11kts, 76p; 2x1-139/21, 2x1-90/36, 4x5-37/17 |
|----|-------|---|---|-------|------|---|---|

© Ivan Gogin, 2015

[home](#)[World navies yesterday](#)[1900](#)

Chile 01 January 1900

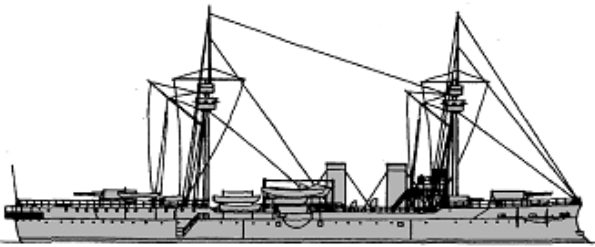
BATTLESHIPS

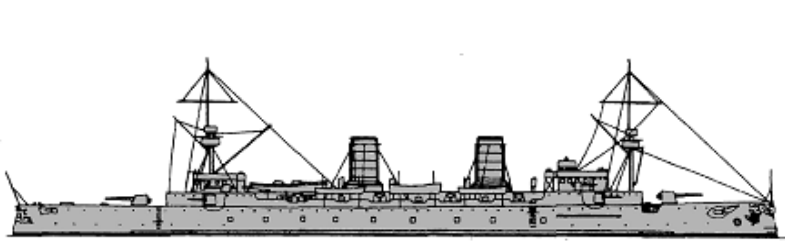
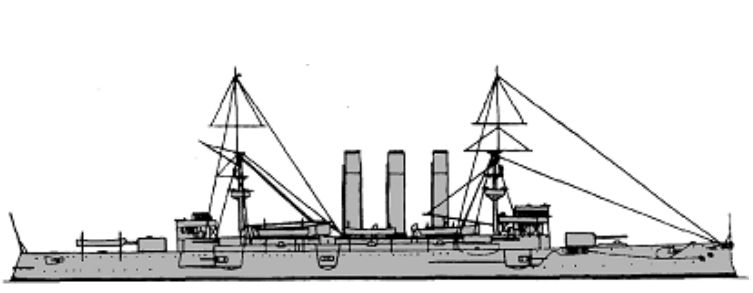

| | | | | | | | |
|-----|--------------|---|---|--------------|------|---|---|
| BB | Capitán Prat | 1 | 1 | Capitán Prat | 1893 |  | 6901t, 100.0ppx18.5x7.0m, 5b,2hte, 12000hp, 18.3kts, 480p; steel- 300belt, 50deck, 275barbettes, 265CT; 4x1-240/36, 4x2-120/45, 6x1-57/40, 4x1-47/40, 10x1-37/20, 4-450TT |
| BC | Cochrane | 1 | 1 | Cochrane | 1874 |  | 3560t, 64.0ppx13.9x6.7m, 6b,2hte, 4300hp, 13.6kts, 300p; iron- 229belt, 203battery, 76CT; 6x1-203/30, 3x1-57/40, 6x1-37/20, 3-356TT |
| MON | Huascár | 1 | 1 | Huascár | 1866 |  | 2030t, 57.9ppx10.7x5.6m, 4b,1hse, 1650hp, 12.3kts, 170p; iron- 114belt, 203turret, 76CT; 1x2-203/26, 2x1-57/40, 2x5-37/17 |

CRUISERS

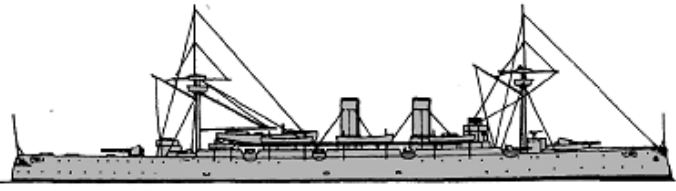
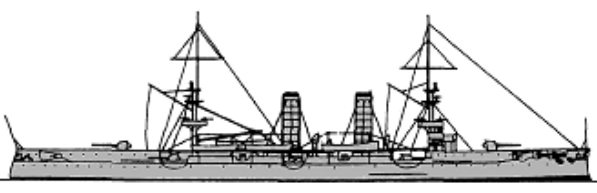
| | | | | | | | |
|----|----------------------|---|---|----------------------|------|--|--|
| CA | Esmeralda | 1 | 1 | Esmeralda | 1896 |  | 7000t, 132.9ppx16.2x6.2m, 12b,2vte, 16000hp, 22.2kts, 500p; Harvey- 152belt, 51deck, 114shields, 203CT; 2x1-203/40, 16x1-152/40, 8x1-76/40, 3-450TT |
| | O'Higgins | 1 | 2 | O'Higgins | 1898 |  | 8500t, 135.2x19.1x6.7m, 30b,2vte, 16000hp, 21kts, 500p; Harvey- 178belt, 51deck, 178turrets, 229CT; 4x1-203/40, 10x1-152/40, 4x1-120/44, 10x1-76/40, 10x1-57/40, 3-450TT |
| | Presidente Errázuriz | 1 | | Presidente Errázuriz | 1892 | | 2047t, 81.8ppx10.9x4.4m, 4b,2hte, 5400hp, 18.3kts, 170p; steel- 60slopes, 35deck, 90shields, |
| | | 2 | | Presidente Pinto | 1892 | | |

| | | | | | | | |
|----|------------------|---|---|------------------|--|--|--|
| | | | | |  | 50CT; 4x1-150/36, 2x1-120/36, 4x1-57/40, 3-356TT | |
| CL | Blanco Encalada | 1 | 3 | Blanco Encalada | 1894 |  | 4568t, 112.8ppx14.2x5.6m, 8b,2vte, 14600hp, 22.8kts, 427p; steel- 102slopes, 44deck, 152shields, 152CT; 2x1-203/40, 10x1-152/40, 12x1-76/40, 12x1-37/20, 5-450TT |
| | Ministro Zenteno | 1 | 4 | Ministro Zenteno | 1898 |  | 3437t, 100.6ppx13.3x5.1m, 8b,2vte, 7500hp, 20.2kts, 317p; steel- 89slopes, 32deck, 102CT; 8x1-152/45, 10x1-57/40, 4x1-37/20, 3-450TT |

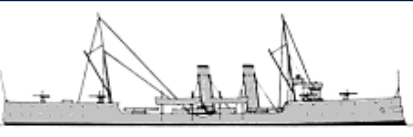
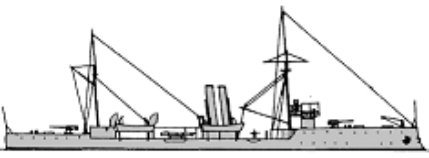
TORPEDO SHIPS

| | | | | | | | |
|-----|-------------------|---|--------------------|------------------------|------|---|--|
| PGT | Almirante Lynch | 2 | 1 | Almirante Lynch | 1890 |  | 713t, 70.1ppx8.4x2.5m, 4b,2vte, 4275-4532hp, 20.3-20.6kts, 87p; steel- 25deck; 3x1-76/40, 4x1-47/40, (1+4x1)-356TT |
| | | | 2 | Almirante Condell | 1890 | | |
| | Almirante Simpson | 1 | 3 | Almirante Simpson | 1896 |  | 800t, 73.2ppx8.4x4.3m, 4b,2vte, 4500hp, 21.5kts; steel- 25deck, 51CT; 2x1-120/40, 4x1-47/40, (1+2x1)-450TT |
| DD | Capitán Orella | 4 | 1 | Capitán Orella | 1896 |  | 300t, 64.9ppx6.6x1.8m, 4b,2vte, 6250hp, 30kts, 65p; 1x1-76/40, 5x1-57/40, 2x1-450TT |
| | | | 2 | Capitán Muñoz Gamero | 1896 | | |
| | | | 3 | Teniente Serrano | 1896 | | |
| | | | 4 | Guardiamarina Riquelme | 1896 | | |
| TB | Glaura | 1 | 1 | Rucumilla | 1882 | No picture | 35t, 30.5x3.8x2.1m, 1b,1hse, 400hp, 19kts, 15p; 1x2-25/42, 2spar torpedoes |
| | Fresia | 1 | 2 | Quidora | 1881 | No picture | 25t, 26.2x3.8x1.5m, 1b,1hse, 400hp, 20kts, 15p; 1x2-25/42, 2spar torpedoes |
| | Sargente Aldea | 1 | 3 | Sargente Aldea | 1886 | No picture | 80t, 38.1x4.0x2.1m, 1b,1vc, 700hp, 20kts, 16p; 2x2-25/42, 2-356TT |
| | Ingeniero Hyatt | 6 | 4 | Cirujano Videla | 1896 |  | 140t, 46.5x4.7x2.4m, 2b,1vte, 2200hp, 27kts, 16p; 3x1-47/40, (1+1x2)-356TT |
| | | | 5 | Ingeniero Mery | 1896 | | |
| | | | 6 | Ingeniero Hyatt | 1896 | | |
| 7 | | | Teniente Rodriguez | 1896 | | | |
| | | | 8 | Ingeniero | 1898 | | |

| | | |
|---|-------------------------|------|
| | Mutilla | |
| 9 | Guardiamarina Contreras | 1898 |

OTHER FIGHTING SHIPS



| | | | | | | | |
|----|------------|---|---|------------|------|------------|--|
| PG | Magallanes | 1 | 1 | Magallanes | 1874 | No picture | 950t, 61.0x9.1x3.5m, 2hc, 1040hp, 11kts, 200p; 1x1-178/14, 1x1-161/14, 2x1-95/16 |
| | Pilcomayo | 1 | 2 | Pilcomayo | 1875 | No picture | 800t, 55.4ppx7.5x3.5m, 1hc, 1080hp, 11kts, 130p; 2x1-147/21, 2x1-121/22 |

© Ivan Gogin, 2015

[home](#)[World navies yesterday](#)[1900](#)

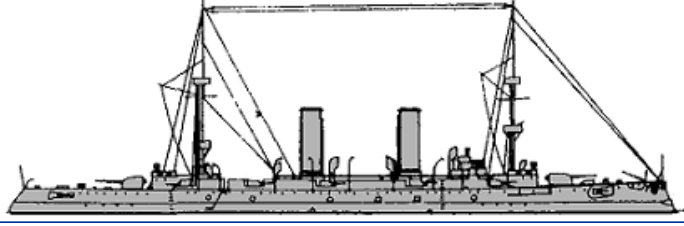
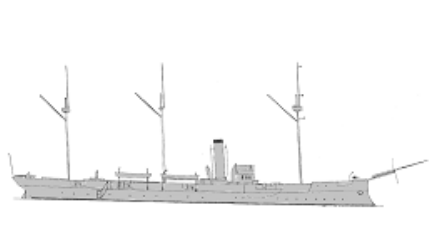

China 01 January 1900

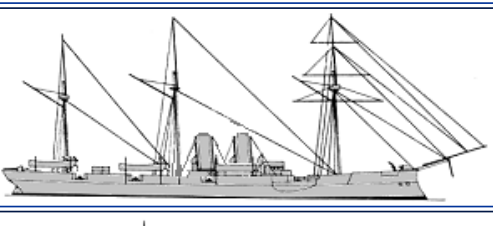
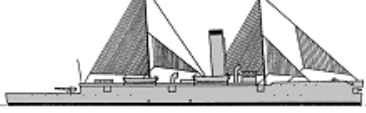
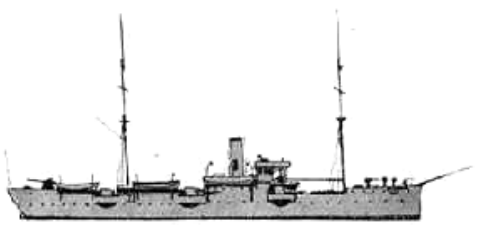
CRUISERS

| | | | | | | |
|-----|----------|----------|--------------|------|---|--|
| CL | Hai Yung | 1 | Hai Yung | 1898 |  | 2950t, 100.0x12.4x5.8m, 8b,2vte, 7500hp, 19.5kts, 244p; 70slopes, 32deck, 51shields, 37CT; 3x1-149/37, 8x1-105/37, 6x1-47/37, 3-356TT |
| | | 2 | Hai Chou | 1898 | | |
| 3 | | Hai Chen | 1898 | | | |
| CL | Hai Chi | 4 | Hai Chi | 1899 |  | 4515t, 129.2x14.2x5.5m, 12b,4vte, 17000hp, 24kts, 350p; Harvey-127slopes, 37deck, 114turrets, 152CT; 2x1-203/45, 10x1-120/45, 16x1-47/40, 5-450TT |
| | | 5 | Hai Tien | 1899 | | |
| CLL | Wei Yuen | 1 | Wei Yuen | 1877 |  | 1258(1-3)-1477(4,5)t, 66.2(1-3)-68.3(4,5)x9.0x3.8m, 750(1-3)-1200(4,5)hp, 11(1-3)-15(4,5)kts, 180p; iron- 32shields; 1x1-160/14(1,3), 2x1-152/26(2), 2x1-149/32(4,5), 6x1-121/22(1,3-5), 7x1-121/22(2), 1x1-120/32(4,5) |
| | | 2 | Chao Wu | 1879 | | |
| | | 3 | Kang Chi | 1880 | | |
| | | 4 | Ching Ch'ing | 1885 | | |
| | | 5 | Heng Hai | 1885 | | |
| CLL | Kai Che | 6 | Kai Che | 1884 |  | 2150(6)-2100(7,8)t, 76.9(6)-76.2(7,8)x11.0x5.6(6)-5.5(7,8)m, 8b,1hc(6)-8b,1hte(7,8), 2400hp, 14.5(6)-16(7,8)kts, 300p; steel-casemates; 2x1-209/20(6), 3x1-178/26(7,8), 7x1-121/22(7,8), 7x1-120/32(6), 6x4-25/42(6), 2-356TT(7,8) |
| | | 7 | King Ch'ing | 1886 | | |
| | | 8 | Huan T'ai | 1888 | | |
| CLL | Nan Thin | 9 | Nan Thin | 1884 |  | 2200t, 84.0x11.0x5.5m, 8b,1hc, 2400hp, 15kts, 250p; 2x1-209/20, 8x1-120/32, 10x4-25/42, 1-356TT |
| | | 10 | Nan Shui | 1884 | | |
| CLL | Pao Min | 11 | Pao Min | 1885 |  | 1480t, 69.4x11.0x4.3m, 6b,2hc, 1900hp, 9kts, 200p; 2x1-149/32, 6x1-120/32, 2x1-47/40 |
| CLL | Tung Chi | 12 | Tung Chi | 1896 |  | 1900t, 77.0ppx10.4x4.9m, 4b,1vc, 1600hp, 11.6kts, 335p; 2x1-152/40, 5x1-120/45, 3x1-57/40, 8x1-37/20 |
| | | | | | | |

| | | | | | | |
|-------|---|----|-------|------|--|---|
| Fu An | 1 | 13 | Fu An | 1897 |  | 1700t, 76.8ppx11.6x5.5m, 4b,1vc, 1600hp, 10kts, 105p; 2x1-57/40 |
|-------|---|----|-------|------|--|---|

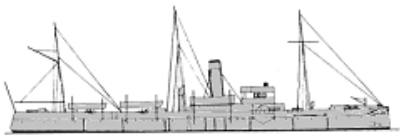
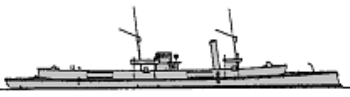
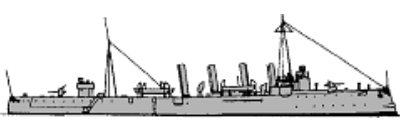
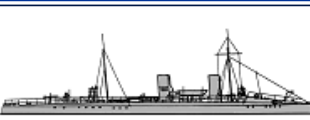
TORPEDO SHIPS

| | | | | | | | |
|-----|------------|---|--------|--|--------------|---|--|
| PGT | Kuang Ping | 1 | 1 | Fu Ch'ing | 1894 |  | 1000t, 71.6x8.2x4.0m, 3b,2hte, 2400hp, 16kts, 120p; steel-25deck, 51CT; 3x1-120/32, 4x1-47/40, (2+2x1)-356TT |
| | Fei Ting | 1 | 2 | Fei Ting | 1894 |  | 401t, 63.7x7.2x3.1m, 2vte, 3000hp, 21.2kts, 50p; steel-45CT; 2x1-95/40, 4x1-47/40, (1+2x2)-356TT |
| | Fei Ying | 1 | 3 | Fei Ying | 1896 |  | 850t, 75.0x8.6x4.0m, 8b,2vte, 5430hp, 22kts, 90p; 25deck, 50shields; 2x1-105/37, 6x1-57/40, 4x1-37/20, (1+2x1)-356TT |
| DD | Hai Lung | 4 | 1 | Hai Hoha | 1898 |  | 284t, 59.0x6.4x2.6m, 4b,2vte, 6000hp, 33.6kts, 57p; 6x1-47/30, 2x1-356TT |
| | | | 2 | Hai Lung | 1898 | | |
| | | | 3 | Hai Hse | 1898 | | |
| | | | 4 | Hai Ying | 1898 | | |
| TB | Lei Fu | 2 | 1, 2 | Lei Fu, Lei Lung | 1884 | No picture | 64t, 35.0x4.0x1.7m, 2b,1vte, 700hp, 19.8kts, 20p; 2x5-37/17, 2-356TT |
| | Lei Chen | 9 | 3-11 | Lei Chen, Lei Chung, Lei Kong, Lei Kwong, Lei Kung, Lei Li, Lei Sun, Lei Tsen, Lei Tui | 1885 | No picture | 27t, 26.0x3.6m, 1b,1vc, 420hp, 19.5kts; 1-356TT |
| | Chang Tze | 2 | 12, 13 | No1 Chang Tze, No3 Lieh Tze | 1895 | No picture | 89t, 39.0x4.8x1.5m, 1b,1vc, 600hp, 18kts, 31p; 2x5-37/17, (2+1x1)-356TT |
| | Chen Tse | 2 | 14, 15 | No2 Chen Tse No4 Su Tse | 1896 1896 |  | 126t, 43.9x5.2x2.4m, 2b,1vte, 1000hp, 18kts, 31p; 2x5-37/17, (2+1x1)-450TT |

OTHER FIGHTING SHIPS

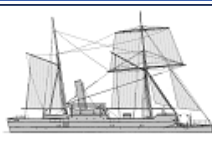
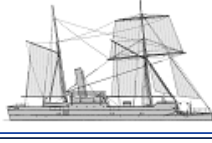
| | | | | | | | |
|----|-------------------|---|----|-------------------|------------|---|---|
| PG | Kwangtung | 2 | 1 | An Lan | 1868 | No picture | 440t, 42.7x7.2x2.7m, 3b,1hr, 255hp, 9.3kts, 60p; 1x1-178/16, 2x1-121/22 |
| | | | 2 | Chen T'ao | 1868 | | |
| | Tien Chi | 1 | 3 | Tien Chi | 1868 | No picture | 600t, 56.4x8.3m, 1b,1hse(sw), 150hp; 15x1-155/8 |
| | Tse Hai | 1 | 4 | Tse Hai | 1869 |  | 600t, 53.4x8.5m, 1b,1hse, 430hp, 12.5kts; 15x1-155/8 |
| | Wei Ching | 1 | 5 | Wei Ching | 1870 | No picture | 1000t, 62.5x9.9m, 1b,1hse, 600hp, 12.5kts; 1x1-178/16, 4x1-127/14 |
| | Chen Hai | 2 | 6 | Chen Hai | 1872 | No picture | 578t, 49.0x8.0x3.2m, 2b,1hse, 480hp, 10kts, 70p; 2x1-160/16(6), 1x1-160/16(7), 4x1-121/22 |
| | | | 7 | Ching Yuan | 1873 | | |
| | Fei Ting | 2 | 8 | Fei Ting | 1876 |  | 420t, 36.6x9.1x2.4m, 1b,2hcr, 270hp, 9.5kts, 30p; iron-13shield, 13CT; 1x1-318/16, 2x1-70/22, 1x4-25/42 |
| | | | 9 | Tse Tien | 1876 | | |
| | Hai Ch'ang Ch'ing | 1 | 10 | Hai Ch'ang Ch'ing | 1877 |  | 430t, 38.1x9.1x2.4m, 1b,2hcr, 70hp, 7.5kts; 1x1-279/12, 2x1-76/28 |
| | | | | 11 | Kuang Yuan | 1886 | |
| | | | | Kuang | | | |

| | | | | | | |
|------------|---|----|-------------|------|------------|---|
| Kuang Yuan | 4 | 12 | Heng | 1886 | No picture | 300t, 33.8x5.5x2.3m, 2hrccr, 65-78hp, 9-10kts; 1x1-149/32, 1x1-88/32, 3x1-37/42 |
| | | 13 | Kuang Li | 1886 | | |
| | | 14 | Kuang Chien | 1886 | | |
| Kuang Keng | 4 | 15 | Kuang Keng | 1887 | No picture | 560t, 43.0x7.3x3.7m, 1vr, 400hp, 11kts; 2x1-121/22, 1x1-100/22, 2x1-47/40 |
| | | 16 | Kuang Hsing | 1887 | | |
| | | 17 | Kuang Jen | 1887 | | |
| | | 18 | Kuang Kuei | 1887 | | |
| Chen Sheng | 1 | 19 | Chen Sheng | 1899 | No picture | 275t, 36.6x6.1x2.1m, 1vc, 400hp, 10kts, 42p; 1x1-76/40, 1x1-57/40 |

CUSTOMS FLOTILLAS

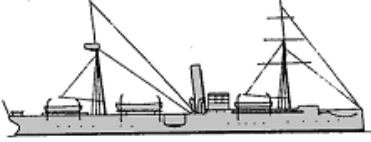
| | | | | | | | |
|-----|---------------|---|----|---------------|-------|--|---|
| CGC | Kua Hsing | 1 | 1 | Kua Hsing | 1869 | No picture | (sw) |
| | Fei Hoo | 2 | 2 | Fei Hoo | 1869 | No picture | 319brt, 39.7x7.4m, 2x1-95/22 |
| | | | 3 | Ling Feng | 1869 | | |
| | Peng Chao Hai | 1 | 4 | Peng Chao Hai | 1869 | No picture | 600brt, 54.9x7.3m; 2x1-121/22, 2x1-95/22 |
| | Ping Ching | 1 | 5 | Ping Ching | 1880 | No picture | 1000t, 64.7x9.2m, 1x1-160/16, 4x1-109/17, 1x1-88/22 |
| | Poo Too | 1 | 6 | Poo Too | 1880s | No picture | 160t |
| | Fee Cheu | 1 | 7 | Fee Cheu | 1887 |  | 1300t, 67.1x9.8x4.0m, 13kts; 2x1-152/26 |
| | Chuen Tiao | 1 | 8 | Chuen Tiao | 1888 | No picture | 716t, 47.3x7.6x3.5m, 10kts; 2x1-95/21, 2x1-47/40 |
| | Likin | 2 | 9 | Likin | 1888 | No picture | 512t, 41.2x7.0x3.5m, 10kts; 2x1-95/21, 2x1-47/40 |
| | | | 10 | Kaipan | 1888 | | |

© Ivan Gogin, 2015

[home](#)[World navies yesterday](#)[1900](#)

Colombia 01 January 1900

OTHER FIGHTING SHIPS

| | | | | | | | |
|-----------|----------------|---|-----------|----------------|------------|--|---|
| PG | Boyacá | 1 | 1 | Boyacá | 1883 | No picture | |
| | La Popa | 1 | 2 | La Popa | 1887 | No picture | |
| PGR | General Pinzón | 1 | 1 | General Pinzón | 1881 | No picture | 740t, (stw), 13kts; 3x1-37/20 |
| | Esperanza | 2 | 2 | Esperanza | 1897 | No picture | 400t, 42.4ppx5.8x0.9m, (stw), 430hp, 15kts; 3x1-37/20 |
| | | | 3 | General Nerín | 1895 | | |
| Chercinto | 1 | 4 | Chercinto | 1896 | No picture | 643t, 56.4x9.4x3.7m, 400hp, 12kts; 3x1-37/20 | |
| APGR | - | 1 | 1 | Bolívar | 1870 | | 981t |

© Ivan Gogin, 2015

[home](#)

[World navies yesterday](#)

[1900](#)

Costa Rica 01 January 1900

TORPEDO SHIPS

| | | | | | | | |
|----|---------|---|---|---------|------|------------|---|
| TB | no name | 1 | 1 | no name | 1890 | No picture | 15t, 18.3x2.8x1.1m, 1b,1vte, 230hp, 17kts; 1x1-47/40, 1-356TT |
|----|---------|---|---|---------|------|------------|---|

© Ivan Gogin, 2015

[home](#)[World navies yesterday](#)[1900](#)

Cuba 01 January 1900

COAST GUARD SHIPS



| | | | | | | | |
|-----|--------------------|---|-----|----------------------------|------|------------|--|
| CGC | Veinte de Mayo | 1 | 1 | Veinte de Mayo | 1895 | No picture | 203t, 45.7x5.6x3.2m, 500hp, 12kts, 43p; 2x1-47/40, 2x1-37/40 |
| | Yara | 1 | 2 | Yara | 1895 | No picture | 449t, 47.2x7.9x4.0m, 600hp, 12kts, 53p; 2x1-57/40, 2x1-47/40 |
| | Alfredo | 1 | 3 | Alfredo | 1896 | No picture | 40t, 18.3x3.7x1.8m, 11kts; 1x1-37/40 |
| | Maceo | 3 | 4-6 | Maceo, Céspedes, Argamonte | 1896 | No picture | 35t, 22.9x3.1x1.7m, 10kts; 1x1-37/40 |
| | Enrique Villuendas | 1 | 7 | Enrique Villuendas | 1899 | No picture | 178t, 40.2x6.1x2.7m, 600hp, 16kts; 2x1-47/40 |

© Ivan Gogin, 2015

[home](#)[World navies yesterday](#)[1900](#)

Denmark 01 January 1900

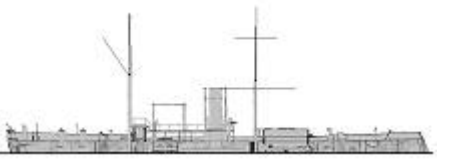
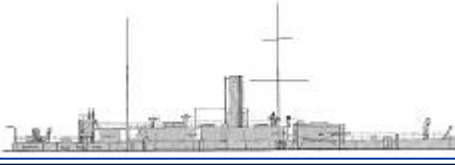
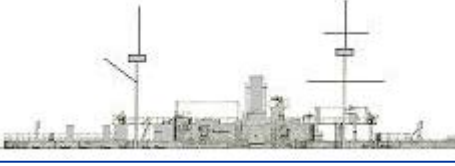
BATTLESHIPS

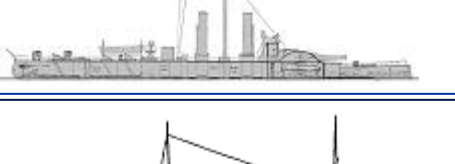
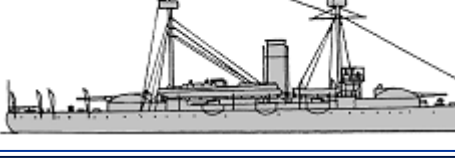

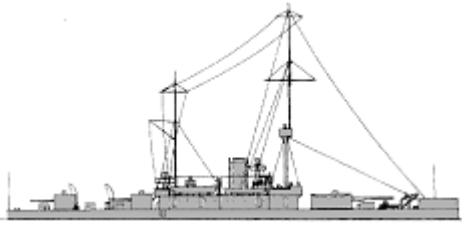

| | | | | | | | |
|----|----------------|---|---|----------------|------|--|--|
| | Rolf Krake | 1 | 1 | Rolf Krake | 1863 |  | 1320t, 57.0x11.6x3.2m, 4b,2hr cr, 750hp, 9.5kts, 150p; iron- 114side, 114turrets; 2x1-203/13, 2x1-87/21, 4x5-37/17 |
| | Lindormen | 1 | 2 | Lindormen | 1869 |  | 2105t, 66.4x12.0x4.4m, 4b,2hr cr, 1500hp, 12kts, 150p; iron- 127side, 140turret; 1x2-229/14, 4x1-87/21, 4x1-37/20 |
| | Gorm | 1 | 3 | Gorm | 1871 |  | 2350t, 71.7x12.2x4.4m, 4b,2hr cr, 1600hp, 12.5kts, 160p; iron- 178side, 203turret; 1x2-254/14, 4x1-57/40, 6x5-37/17 |
| | Odin | 1 | 4 | Odin | 1874 |  | 3230t, 73.4ppx14.8x5.0m, 4b,2hr cr, 2300hp, 12kts, 206p; compound- 203side, 203battery; 4x1-254/15, 4x1-87/21, 6x5-37/17 |
| BC | Helgoland | 1 | 5 | Helgoland | 1879 |  | 5332t, 79.1x18.0x5.9m, 8b,2hr cr, 4000hp, 13.7kts, 331p; iron- 305belt, 254barbette; 1x1-305/19, 4x1-263/19, 4x1-120/22, 2x1-57/40, 3x1-37/20, 4x5-37/17, 2-381TT, 3-356TT |
| | Tordenskjold | 1 | 6 | Tordenskjold | 1882 |  | 2462t, 67.8x13.2x4.8m, 8b,2vc, 2600hp, 12.7kts, 206p; compound- 97slopes, 38deck, 203barbette; 1x1-355/22, 4x1-120/22, 8x5-37/17, 1-381TT, 3-356TT |
| | Iver Hvitfeldt | 1 | 7 | Iver Hvitfeldt | 1887 |  | 3478t, 74.5ppx15.1x5.6m, 8b,2vc, 5100hp, 15.2kts, 277p; compound- 295belt, 53deck, 215barbette, 115CT; 2x1-263/32, 4x1-120/27, 2x1-57/40, 8x5-37/17, 2-381TT, 2-356TT |
| | Skjold | 1 | 8 | Skjold | 1897 |  | 2195t, 69.4x11.6x4.2m, 4b,2vte, 2400hp, 14kts, 138p; Harvey- 229belt, 50deck, 250turret; 1x1- |

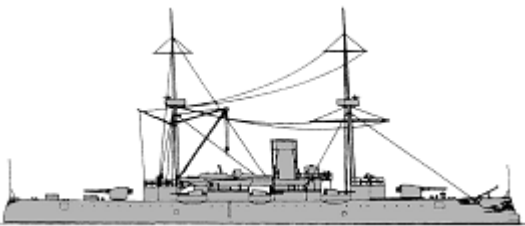
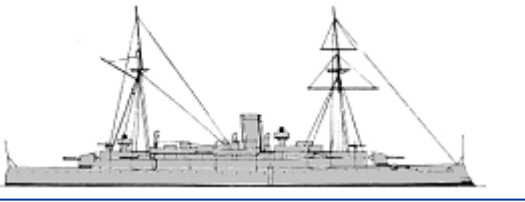
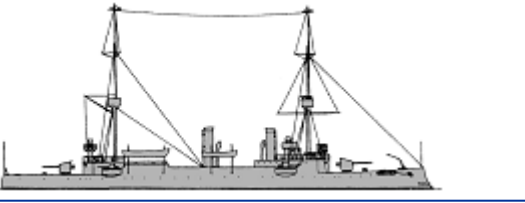



| | | | | | | |
|--|--|--|--|--|---|-------------------------------|
| | | | | |  | 240/37, 3x1-120/38, 4x1-47/40 |
|--|--|--|--|--|---|-------------------------------|

CRUISERS



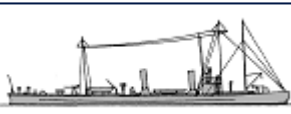

| | | | | | | | |
|-----|------------|---|---------|------------|------|--|--|
| CL | St. Thomas | 1 | 1 | St. Thomas | 1872 | No picture | 1550t, 70.1x10.0x5.2m, 1800hp, 13kts, 182p; 1x1-203/13, 4x1-154/16, 1x1-84/13 |
| | Valkyrien | 1 | 2 | Valkyrien | 1890 |  | 3020t, 85.8x13.2x5.5m, 6b,2vte, 5200hp, 17kts, 282p; steel-65deck; 2x1-209/32, 6x1-149/32, 4x1-57/40, 8x5-37/17, 5-381TT |
| | Hekla | 1 | 3 | Hekla | 1891 |  | 1300t, 72.3x10.4x3.5m, 8b,2vte, 3000hp, 17kts, 156p; steel-43deck; 2x1-149/32, 4x1-57/40, 6x5-37/17, 4-381TT |
| | Gejser | 2 | 4 | Gejser | 1893 |  | 1282(4)-1342(5)t, 72.3x10.4x3.5m, 8b,2vte, 3000hp, 17kts, 156p; steel-50(4)-45(5)deck; 2x1-120/38, 4x1-87/37, 2x1-37/20, 4x5-37/17, 1-450TT, 3-381TT |
| | | 5 | Hejmdal | 1895 | | | |
| CLL | Dagmar | 1 | 1 | Dagmar | 1862 | No picture | 1222t, 54.4x10.3x5.0m, 1hda, 500hp, 9kts, 190p; 8x1-120/27, 2x5-37/17 |
| | Ingolf | 1 | 2 | Ingolf | 1878 | No picture | 1012t, 63.9x8.5x4.2m, 630hp, 10.2kts, 156p; 4x1-120/38, 4x5-37/17 |
| | Fyen | 1 | 3 | Fyen | 1884 | No picture | 2663t, 69.0ppx13.8x6.1m, 2600hp, 12.5kts, 300p; 2x1-149/32, 14x1-149/22, 8x5-37/17, 2-356TT |

TORPEDO SHIPS

| | | | | | | | |
|-------|------------|---|---|-------------|------|---|---|
| TB1cl | Nr.6 | 1 | 1 | Sværdfisken | 1881 |  | 58t, 33.5x3.7x1.8m, 1b,1vc, 600hp, 17kts, 15p; 1x5-37/17, 2-381TT |
| | Delfinen | 1 | 2 | Delfinen | 1883 |  | 66t, 33.6x3.6x0.7m, 1b,1vc, 670hp, 17kts, 15p; 1x5-37/17, 2-381TT |
| | Hvalrossen | 1 | 3 | Hvalrossen | 1884 |  | 74t, 34.5x3.7x2.0m, 1b,1vc, 660hp, 17kts, 15p; 1x5-37/17, 2-381TT |
| | Støren | 2 | 4 | Støren | 1887 |  | 107t, 39.7x4.2x2.2m, 2b,1vc, 1200hp, 18.5kts, 20p; 2x5-37/17, (2+1x2)-381TT |
| | | | 5 | Søløven | 1887 | | |
| | Nahrvalen | 2 | 6 | Nahrvalen | 1888 |  | 111t, 41.1x4.2x2.2m, 2b,1vc, 1200hp, 18.5kts, 20p; 2x5-37/17, (2+1x2)-381TT |
| | | | 7 | Havhesten | 1888 | | |

| | | | | | | | |
|-------|-------------|---|--------|-------------|-----------|---|--|
| | Springeren | 1 | 8 | Springeren | 1891 |  | 89t, 36.3x4.0x2.1m, 2b,1vc, 800hp, 17.5kts, 17p; 2x5-37/17, 2-450TT |
| | Nordkaperen | 2 | 9 | Nordkaperen | 1893 |  | 127t, 42.5x4.3x2.2m, 2b,1vc, 1300hp, 19kts, 20p; 2x5-37/17, 2-450TT, 1x2-381TT |
| | | | 10 | Makrelen | 1894 | | |
| | Hajen | 1 | 11 | Hajen | 1896 |  | 141t, 42.9x4.6x2.5m, 2b,2vte, 2000hp, 22kts, 25p; 1x1-47/40, 1x5-37/17, 2-450TT, 1x2-381TT |
| | Havørnen | 2 | 12 | Havørnen | 1897 |  | 142t, 44.4x4.7x2.4m, 2b,2vte,2 100hp, 22kts, 25p; 1x1-47/40, 1x5-37/17, (2+1x2)-450TT |
| | | | 13 | Søbjørnen | 1898 | | |
| TB2cl | Nr.4 | 1 | 1 | Nr.2 | 1879 |  | 32t, 27.8x3.0x1.6m, 1b,1vc, 350hp, 15.5kts, 12p; 1x1-37/20, 1-356TT |
| | Nr.5 | 1 | 2 | Nr.3 | 1880 | No picture | 37t, 29.0xxm, 1b,1vc, 450hp, 15kts; 1x1-37/20, 2-356TT |
| | P8 | 2 | 3, 4 | P8, 9 | 1894-1895 | No picture | 48t, 25.6x3.8x1.8m, 1vte, 330hp, 13kts, 13p; 1x1-47/40, 1x5-37/17, 1x1-356TT |
| | Nr.10 | 2 | 5, 6 | P2, 3 | 1878 | No picture | 14t, 14.6x2.8x1.2m, 1b,1hda, 10.5kts, 8p; 1x5-37/17 |
| | Nr.4 | 1 | 7 | Nr.4 | 1882 | No picture | 15t, 18.8x2.2x1.1m, 1b,1vc, 150hp, 13kts, 6p; 1x1-37/20, 2-356TT |
| | Nr.6 | 2 | 8, 9 | Nr.6, 7 | 1884 | No picture | 15t, 20.1x2.4x1.3m, 1b,1vc, 150hp, 13kts, 6p; 1x1-37/20, 2-356TT |
| | Nr.8 | 2 | 10, 11 | Nr.8, 9 | 1886 | No picture | 15t, 20.6x2.4x1.2m, 1b,1vc, 170hp, 13kts, 6p; 1x1-37/20, 2-356TT |
| | Nr.10 | 2 | 12, 13 | Nr.10, 11 | 1888 | No picture | 17t, 21.0x2.4x1.2m, 1b,1vc, 180hp, 13.5kts, 6p; 1x1-37/20, 2-356TT |
| | Nr.12 | 2 | 14, 15 | Nr.12, 13 | 1889 | No picture | 25t, 23.8x2.7x1.3m, 1b,1vc, 350hp, 15kts, 6p; 1x1-37/20, 2-356TT |
| | P4 | 4 | 16-19 | P4-7 | 1889-1890 | No picture | 20t |

OTHER FIGHTING SHIPS

| | | | | | | | |
|----|----------|---|----|--------------|------|---|--|
| | Absalon | 2 | 1 | Absalon | 1862 |  | 533t, 47.8x7.9x3.3m, 500hp, 11kts, 50p; iron-64belt; 2x1-120/27(1), 2x1-87/21(1), 2x5-37/17(2), 1-381TT(2), 1x1-356TT(2) |
| | | | 2 | Esbern Snare | 1862 | | |
| | Fylla | 1 | 3 | Diana | 1864 | No picture | 560t, 47.8x7.9x3.1m, 500hp, 9.7kts, 58p; 2x1-37/20 |
| | Falster | 1 | 4 | Falster | 1874 |  | 390t, 34.3x8.8x2.6m, 510hp, 10.5kts, 50p; 1x1-254/18, 2x1-84/13 |
| PG | Øresund | 3 | 5 | Øresund | 1875 |  | 240t, 26.1x8.0x2.1m, 200hp, 7.5kts, 36p; 1x1-254/18, 2x1-84/13 |
| | | | 6 | Store Bælt | 1875 | | |
| | | | 7 | Lille Bælt | 1876 | | |
| | Møen | 1 | 8 | Møen | 1875 | No picture | 409t, 34.3x8.8x2.6m, 523hp, 9kts, 35p; 1x1-254/18, 6x5-37/17 |
| | Grønsund | 2 | 9 | Grønsund | 1883 |  | 247(9)-268(10)t, 36.3x6.1x2.5m, 300(9)-400(10)hp, 10(9)-10.5(10)kts, 46-49p; 2x1-57/40(9), 2x1-47/40(10), 2x5-37/17(9) |
| | | | 10 | Guldborgsund | 1885 | | |
| BR | Ørnen | 1 | 1 | Ørnen | 1880 | No picture | 300t |

MINE WARFARE SHIPS

| | | | | | | | |
|----|-----------|---|---|-----------|------|------------|---|
| ML | Hjælperen | 1 | 1 | Hjælperen | 1891 | No picture | 288t, 38.3x6.8x2.3m, 330hp, 25p; 3x5-37/17, mines |
|----|-----------|---|---|-----------|------|------------|---|



© Ivan Gogin, 2014

[home](#)[World navies yesterday](#)[1900](#)

Dominican Republic 01 January 1900

OTHER FIGHTING SHIPS

| | | | | | | | |
|----|---------------|---|---|---------------|------|------------|---|
| PG | El Presidente | 1 | 1 | El Presidente | 1873 | No picture | 389t, 63.7x6.6m, 105hp, 13.8kts, 50p; 4x1-121/22 |
| | Independencia | 1 | 2 | Independencia | 1894 | No picture | 322t, 51.8x7.6m, 2vte, 15kts; 7x1-small guns |
| | Restauración | 1 | 3 | Restauración | 1896 | No picture | 1000t, 65.2x9.1m, 2vte, 14kts; 4x1-120/40, 5x1-small guns |

© Ivan Gogin, 2015

[home](#)

[World navies yesterday](#)

[1900](#)

Ecuador 01 January 1900

TORPEDO SHIPS

| | | | | | | | |
|----|------------|---|---|------------|-------|---|-----|
| TB | Tungurahua | 1 | 1 | Tungurahua | 1890s |  | 65t |
|----|------------|---|---|------------|-------|---|-----|

ESCORTS

| | | | | | | | |
|----|---|---|---|----------|------|--|-----------------|
| AY | - | 1 | 1 | Cotopaxi | 1884 | | 300t; 4x1-76/40 |
|----|---|---|---|----------|------|--|-----------------|

OTHER FIGHTING SHIPS



| | | | | | | | |
|-----|---|---|---|----------------|--|--|--------|
| APG | - | 2 | 1 | Nueve de Julio | | | |
| | | | 2 | Patria | | | 300brt |

© Ivan Gogin, 2015

[home](#)[World navies yesterday](#)[1900](#)

Egypt 01 January 1900

ESCORTS

| | | | | | | | |
|----|--------------|---|---|--------------|------|---|--------|
| PC | Noor El Bahr | 1 | 1 | Noor El Bahr | 1884 |  | 450t |
| | Nesim | 1 | 2 | Nesim | 1885 | No picture | 81t |
| | Marda | 1 | 3 | Marda | 1886 | No picture | 154t |
| | Zarif | 1 | 4 | Zarif | 1886 | No picture | 144t |
| | Saria | 1 | 5 | Saria | 1886 | No picture | 71t |
| | Abbas | 1 | 6 | Abbas | 1891 |  | 298brt |

OTHER FIGHTING SHIPS

| | | | | | | | |
|-----|------------|---|-----|----------------------------------|-----------|------------|------------------------|
| PG | Khartum | 1 | 1 | Khartum | 1862 | No picture | 455t |
| | Dongola | 1 | 2 | Dongola | 1863 | No picture | 300t |
| | Jeafferieh | 1 | 3 | Jeafferieh | 1865 | No picture | 690t |
| PGR | Tamai | 4 | 1-4 | Tamai, Hafir, Metemmeh, Abu Klea | 1884-1885 | No picture | 74t, (stw); 1x1-76/40 |
| | El Zafir | 3 | 5 | El Zafir | 1896 | No picture | 128t, (stw); 1x1-76/40 |
| | | | 6 | El Fateh | 1897 | | |
| | | | 7 | El Nasir | 1897 | | |
| | Sultan | 3 | 8 | Sheik | 1896 | No picture | 140t; 1x1-76/40 |
| | | | 9 | Sultan | 1896 | | |
| | | | 10 | Melik | 1897 | | |

© Ivan Gogin, 2015

[home](#)

[World navies yesterday](#)

[1900](#)

El Salvador 01 January 1900

OTHER FIGHTING SHIPS

| | | | | | | | |
|----|-----------|---|---|-----------|------|------------|---------------------------|
| PG | Cuscatlan | 1 | 1 | Cuscatlan | 1890 | No picture | 75t, 10kts; 1x1-small gun |
|----|-----------|---|---|-----------|------|------------|---------------------------|

© Ivan Gogin, 2015

[home](#)[World navies yesterday](#)[1900](#)



France 01 January 1900

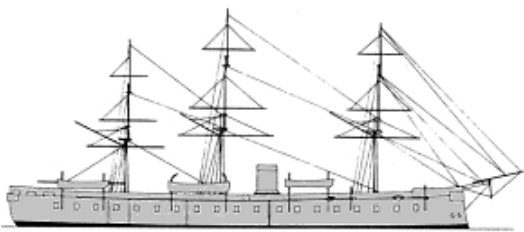
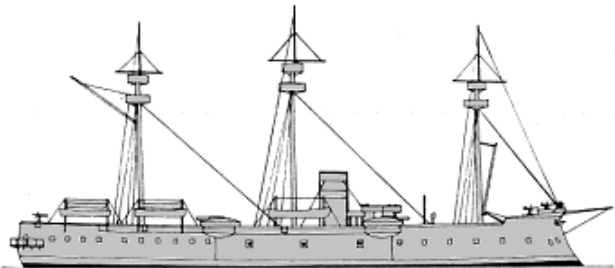
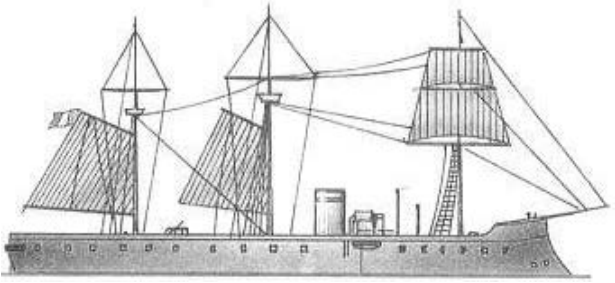

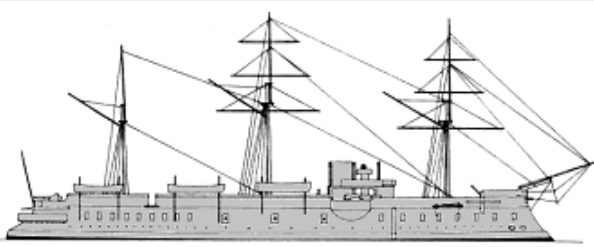
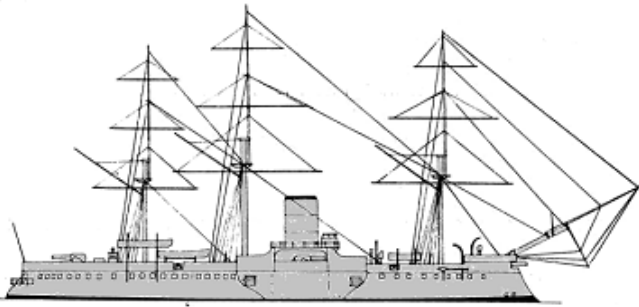
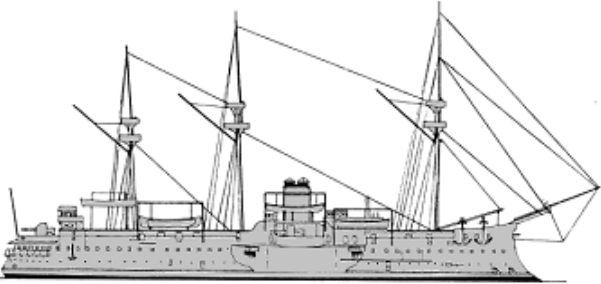
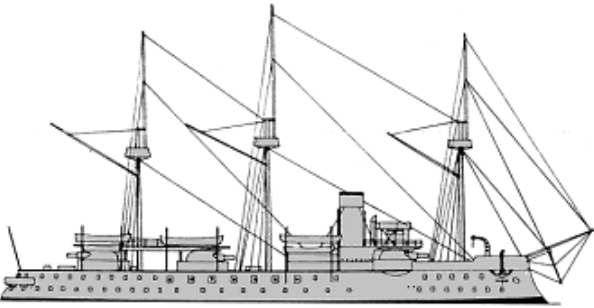
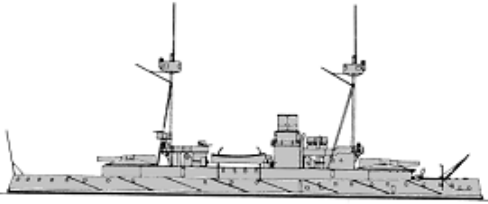
BATTLESHIPS

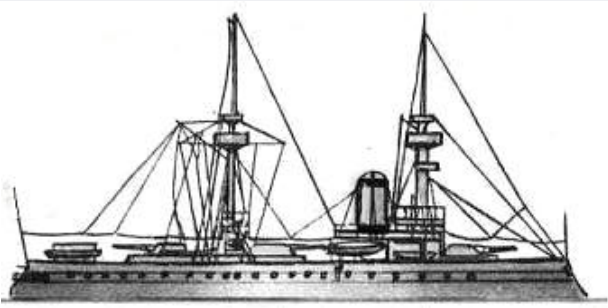
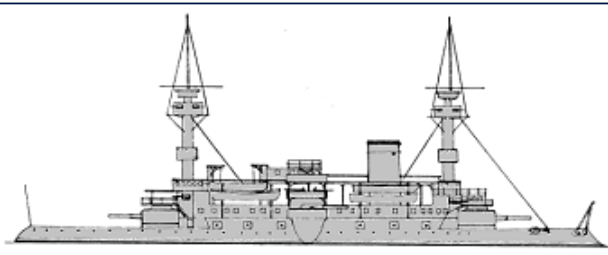
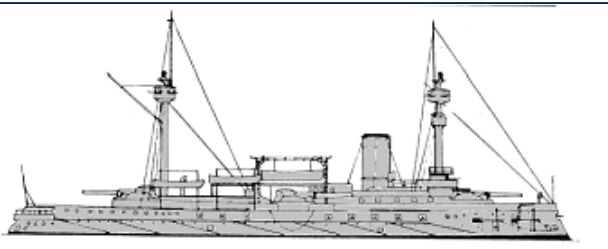
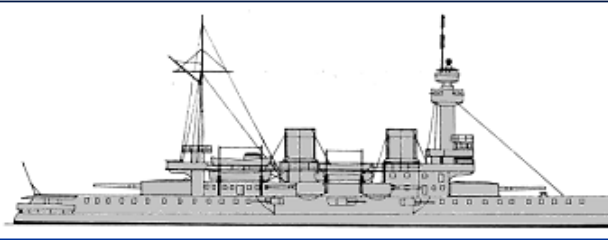
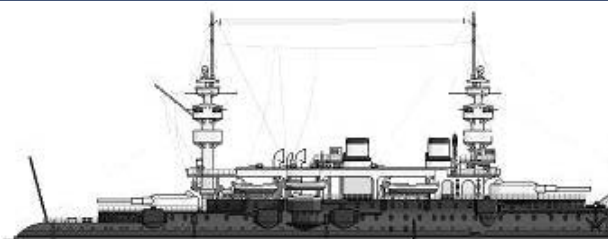
| | | | | | | |
|-----------|---|---|-----------|------|--|---|
| Couronne | 1 | 1 | Couronne | 1862 |  | 5983t, 80.9x16.7x8.2m, 8b,1hr, 2900hp, 13kts, 570p; iron-120belt; 8x1-240/18, 4x1-194/20, 2x1-120/25, 12x5-37/20 |
| Richelieu | 1 | 2 | Richelieu | 1875 |  | 8984t, 101.7x17.5x8.7m, 8b,2hr, 4200hp, 13kts, 750p; iron-220belt, 13deck, 160barbettes, 100CT; 6x1-274/18, 5x1-240/18, 6x1-139/21, 18x5-37/20, 4-350TT |
| Friedland | 1 | 3 | Friedland | 1877 |  | 8850t, 101.1x17.7x9.0m, 8b,1hr, 4400hp, 13.3kts, 700p; iron-200belt, 160battery; 8x1-274/18, 8x1-139/21, 22x5-37/20, 4-350TT |
| Colbert | 2 | 4 | Colbert | 1877 | | 8750t, 101.1(4)-102.1(5)x17.5x8.5(4)-8.8(5)m, 8b,1hr, 4600hp, 14kts, 774p; iron-220belt, 15deck, 160battery; 8x1-274/18, 2x1-240/18, 6x1-139/21, 14x5-37/20(4), 18x5-37/20(5), 4-350TT(4), 6-350TT(5) |
| | | 5 | Trident | 1878 | | |

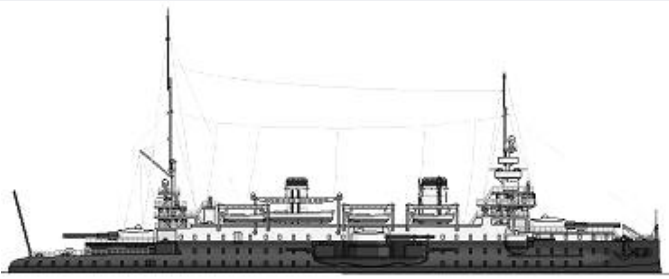
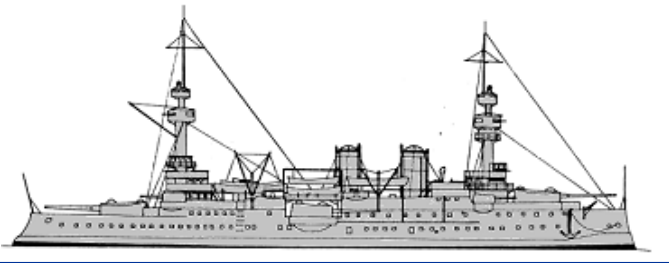
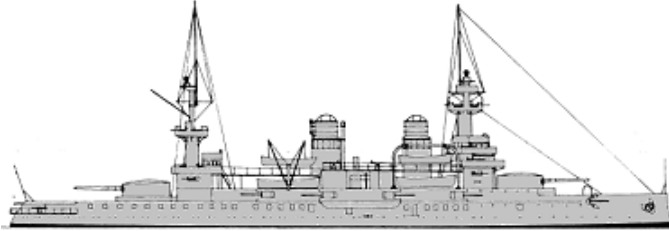
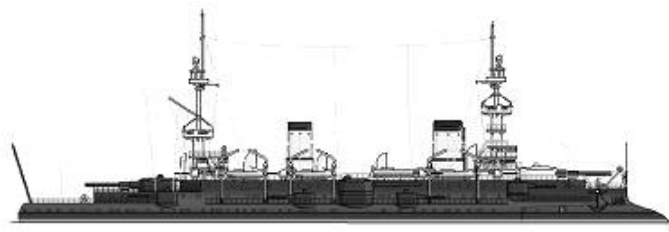
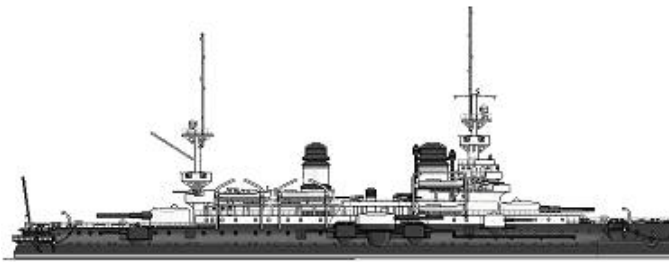
| | | | | | | |
|----------------|---|----|----------------|---|--|---|
| | | | |  | | |
| Redoutable | 1 | 6 | Redoutable | 1878 |  | 9224t, 100.7x19.7x7.8m, 8b,1vte, 6200hp, 14.7kts, 705p; iron-350belt, 60deck, 300battery; 3x1-274/40, 1x1-274/29, 4x1-240/30, 6x1-100/45, 5x1-65/50, 14x1-47/40, (5x5+5x1)-37/20, 2-350TT |
| Courbet | 2 | 7 | Courbet | 1886 |  | 10450t, 100.2x21.3x8.1(7)-8.2(8)m, 12b,2vc, 8300hp, 15(7)-15.5(8)kts, 689p; iron- 380belt, 60deck, 240battery; 4x1-340/18(7), 4x1-320/25(8), 3x1-274/45(7), 4x1-274/18(8), 6x1-139/28(7), 6x1-139/21(8), 4x1-65/50(7), 2x1-65/50(8), 14x1-47/40(7), 6x1-47/40(8), (19x5+7x1)-37/20(7), (8x5+12x1)-37/20(8), 5-350TT |
| | | 8 | Dévastation | 1882 | | |
| Amiral Duperré | 1 | 9 | Amiral Duperré | 1883 |  | 11030t, 98.9x20.4x8.4m, 12b,2vc, 7300hp, 14kts, 660p; iron-560belt, 60deck, 300barbettes, 40CT; 3x1-340/21, 5x1-165/28, 14x1-139/21, 2x1-65/50, 22x1-47/40, (18x5+18x1)-37/20, 4-350TT |
| Terrible | 4 | 10 | Terrible | 1887 |  | 7530t, 85.3x18.0x8.0m, 12b,2vc(10-12)-10b,2vc(13), 6500hp, 14.5(10-12)-15(13)kts, 373p; steel(10)- compound(11-13)-500belt, 105deck, 450barbettes, 30CT; 2x1-340/35(10), 2x1-420/22(11-13), 4x1-100/26, 4x1-47/40(10), 2x1-47/40(11-13), 16x5-37/20, 4-350TT |
| | | 11 | Indomptable | 1887 | | |
| | | 12 | Caiman | 1888 | | |
| | | 13 | Requin | 1888 | | |
| | | 14 | Amiral Baudin | 1888 | | |

| | | | | | | | |
|--------|----------------|----|--------|----------------|------|--|--|
| BB | Amiral Baudin | 2 | 15 | Formidable | 1889 |  | 11720t, 101.0x21.3x8.5m, 12b,2vc, 8400(14)-9700(15)hp, 15(14)-16(15)kts, 625(14)-650(15)p; steel/compound- 550belt, 100deck, 400barbettes, 120CT; 2x1-370/28, 8x1-165/30, 8x1-139/45(14), 10x1-139/28(15), 2x1-65/50(14), 20x1-47/40(14), 1x1-47/40(15), 12x5-47/20(15), (2x5+6x1)-37/20(14), 18x5-37/20(15), 4-380TT |
| | Hoche | 1 | 16 | Hoche | 1890 |  | 10580t, 102.6x20.2x8.3m, 16b,2vte, 12000hp, 16.5kts, 611p; compound- 450belt, 100deck, 400turrets, 65CT; 2x1-340/29, 2x1-274/29, 12x1-139/45, 4x1-65/50, 10x1-47/40, 10x5-37/20, 3-380TT |
| | Marceau | 3 | 17 | Marceau | 1891 |  | 10558(17)-10810(18)-10680(19)t, 101.6x20.2(17)-20.0(18,19)x8.2-8.4m, 8b,2vc(17,19)-12b,2vc(18), 11000hp, 16kts, 643-651p; compound(17,18)-steel(19)- 450belt, 90deck, 400barbettes, 150CT; 4x1-340/29, 16x1-139/30(17), 17x1-139/30(18,19), 3x1-65/50(17), 6x1-65/50(18,19), 9x1-47/40(17), 18x1-47/40(18,19), 8x5-37/20(17), 12x5-37/20(18,19), 3-380TT(17), 5-380TT(18,19) |
| | | | 18 | Neptune | 1892 | | |
| | | | 19 | Magenta | 1893 | | |
| | Brennus | 1 | 20 | Brennus | 1896 |  | 11190t, 114.0x20.4x8.3m, 32b,2vte, 13900hp, 18kts, 673p; steel/compound- 450belt, 80deck, 450turrets, 150CT; (1x2+1x1)-340/42, 10x1-165/45, 4x1-65/50, 14x1-47/40, (8x1+6x5)-37/20, 4-450TT |
| | Charles Martel | 1 | 21 | Charles Martel | 1897 |  | 11693t, 119.0x21.6x8.4m, 24b,2vte, 14900hp, 18kts, 644p; nickel steel- 450belt, 70deck, 380turrets, 230CT; 2x1-305/45, 2x1-274/45, 8x1-139/45, 4x1-65/50, 12x1-47/40, 8x5-37/20, 4-450TT |
| Carnot | 1 | 22 | Carnot | 1897 | | 11954t, 119.0x21.4x8.4m, 24b,2vte, 16300hp, 17.8kts, 647p; nickel steel- 450belt, 70deck, 380turrets, 230CT; 2x1-305/45, | |

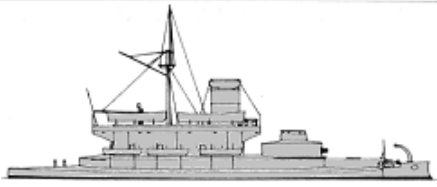
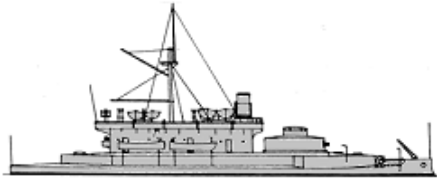
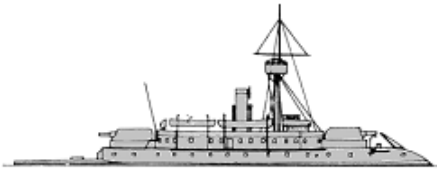
| | | | | | | |
|---------------|---|----|---------------|---|--|---|
| | | | |  | 2x1-274/45, 8x1-139/45, 4x1-65/50, 12x1-47/40, 8x5-37/20, 4-450TT | |
| Jauréguiberry | 1 | 23 | Jauréguiberry | 1897 |  | 11637t, 111.9x22.2x8.4m, 24b,2vte, 14400hp, 17.7kts, 631p; nickel steel- 450belt, 70deck, 380turrets, 230CT; 2x1-305/45, 2x1-274/45, 4x2-139/45, 4x1-65/50, 12x1-47/40, 8x5-37/20, 4-450TT |
| Charlemagne | 2 | 24 | Charlemagne | 1897 |  | 11300t, 117.7x20.2x8.4m, 20b,3vte, 15000hp, 18kts, 694p; Harvey- 400belt, 90deck, 380turrets, 330CT; 2x2-305/40, 10x1-139/45, 8x1-100/45, 20x1-47/40, 4x1-37/20, 4-450TT |
| | | 25 | Gaulois | 1899 | | |
| Masséna | 1 | 26 | Masséna | 1898 |  | 11735t, 115.5x20.3x8.8m, 24b,3vte, 14200hp, 17kts, 667p; nickel steel- 450belt, 110decks, 400turrets, 350CT; 2x1-305/40, 2x1-274/45, 8x1-139/45, 8x1-100/45, 12x1-47/40, (3x5+5x1)-37/20, 4-450TT |
| Bouvet | 1 | 27 | Bouvet | 1898 |  | 12007t, 122.6x21.4x8.4m, 32b,3vte, 15000hp, 18kts, 666p; Harvey- 400belt, 70decks, 380turrets, 300CT; 2x1-305/40, 2x1-274/45, 8x1-139/45, 8x1-100/45, 12x1-47/40, (2x5+5x1)-37/20, 4-450TT |
| Tonnerre | 2 | 1 | Tonnerre | 1879 |  | 5765(1)-5871(2)t, 76.0x17.6x6.5-7.2m, 8b,1hc, 4200-4500hp, 13.7kts, 220p; iron- 330belt, 50deck, 330turret; 1x2-274/20, 4x1-47/40, 4x5-37/20(1), 6x5-37/20(2) |
| | | 2 | Fulminant | 1882 | | |

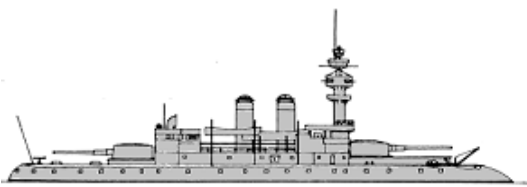
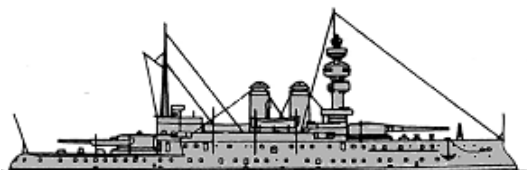
| | | | | | | | |
|------------------|----------|----|------------------|----------|--|--|---|
| BC | | | | |  | | |
| | Tempête | 2 | 3 | Tempête | 1879 |  | 4793(3)-4635(4)t, 76.0x17.6x5.8m, 4b,1hc(3)-4b,2hc(4), 2000hp, 11.7(3)-10.7(4)kts, 174p; iron- 330bekt, 50deck, 350turret; 1x2-340/18(4), 1x2-274/20(3), 2x1-47/40(4), 4x5-37/20(3), 6x5-37/20(4), 2-350TT(4) |
| | | | 4 | Vengeur | 1882 | | |
| | Tonnant | 1 | 5 | Tonnant | 1884 |  | 5010t, 75.8x17.8x5.3m, 4b,1hc, 2000hp, 11.6kts, 175p; iron- 450belt, 50deck, 370barbettes; 2x1-340/18, 8x5-37/20 |
| | Furieux | 1 | 6 | Furieux | 1887 |  | 5925t, 75.9x17.8x7.1m, 8b,2vc, 4600hp, 13kts, 235p; steel- 450belt, 90deck, 450barbettes; 2x1-340/21, 4x1-47/40, 10x5-37/20, 2-350TT |
| | Jemmapes | 2 | 7 | Jemmapes | 1894 |  | 6476t, 89.7x17.5x7.1m, 16b,2hte, 9000hp, 16.7kts, 313p; NS- 450belt, 100deck, 450turrets, 100CT; 2x1-340/42, 4x1-100/45, 4x1-47/40, 10x5-37/20, 2-450TT |
| | | | 8 | Valmy | 1894 | | |
| Amiral Tréhouart | 2 | 9 | Amiral Tréhouart | 1896 |  | 6681t, 89.7x17.8x7.1m, 16b,2vte, 8500hp, 16.5-17kts, 343-362p; NS- 450belt, 110deck, 450turrets, 100CT; 2x1-305/45, 8x1-100/45, 4x1-47/40, 10x5-37/20(9), (8x5+4x1)-37/20(10), 2-450TT | |
| | | 10 | Bouvines | 1894 | | | |

CRUISERS

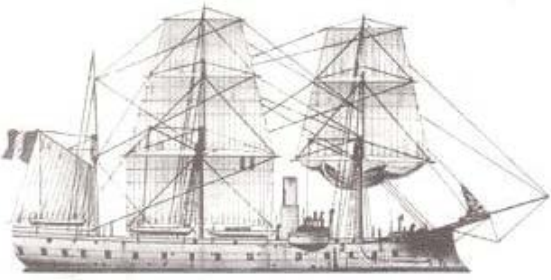
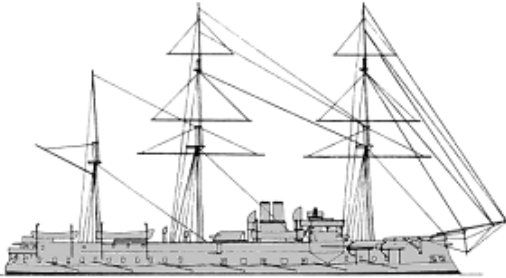
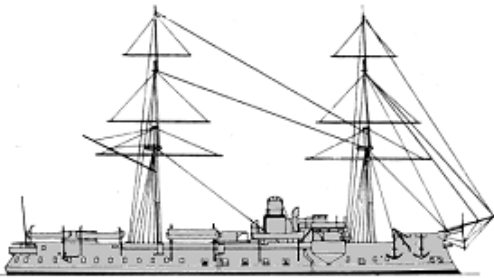
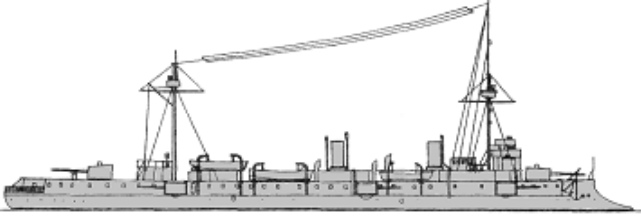
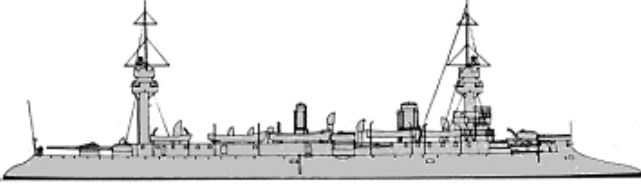

| | | | | | | |
|------------------|---|---|-------------|------|--|--|
| La Galissonnière | 2 | 1 | Triomphante | 1879 |  | 4585t, 78.6x14.9x7.4m, 4b,1vc, 2400hp, 12.7kts, 382p; iron- 150belt, 120barbettes; 6x1-240/18, 1x1-194/20, 6x1-139/21, 8x5-37/20, 4-350TT(1) |
| | | 2 | Victorieuse | 1877 | | |

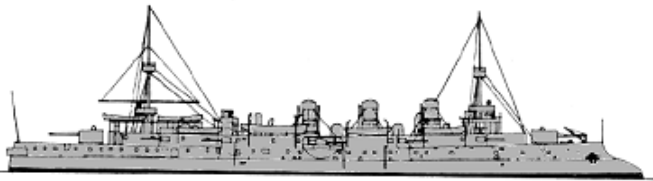
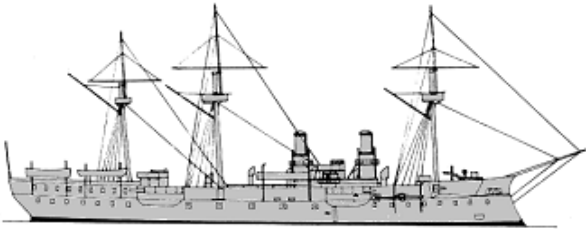
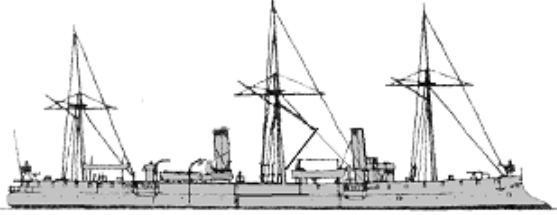
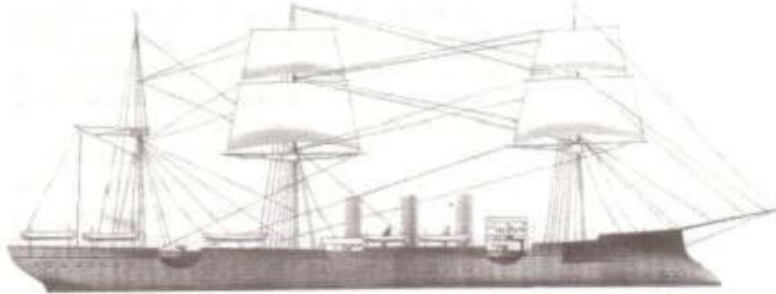
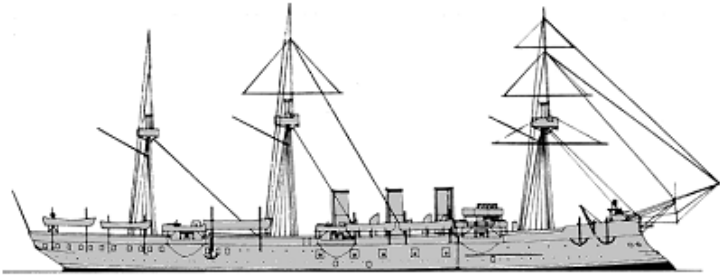
| | | | | | | |
|----|----------------|------|-------------------|---|--|---|
| | | | |  | | |
| CA | Bayard | 1 3 | Turenne | 1882 |  | 6260t, 81.0x17.5x7.7m, 8b,2vc, 4400hp, 14kts, 451p; iron- 250belt, 50deck, 200barbettes; 4x1-240/18, 2x1-194/20, 6x1-139/21, 4x1-47/40, 12x5-37/20, 2-350TT |
| | Vauban | 2 | Duguesclin | 1886 |  | 6112t, 81.0x17.5x7.7m, 8b,2vc, 4400hp, 14-14.5kts, 440p; iron- 250belt, 50deck, 200barbettes; 4x1-240/18, 1x1-194/20, 6x1-139/21, 4x1-47/40(5), 12x5-37/20, 2-350TT |
| | | 5 | Vauban | 1885 | | |
| | Amiral Charner | 4 | Amiral Charner | 1894 |  | 4681-4736t, 110.0x14.0x6.0m, 16b,3hte(6,8,9)-16b,3vte(7), 8000(6,8,9)-8700(7)hp, 18.2(6,8,9)-19(7)kts, 393p; steel- 90belt, 40deck, 110turrets, 110CT; 2x1-194/45, 6x1-139/45, 4x1-65/50, 4x1-47/40, 6x5-37/20, 4-450TT |
| | | 7 | Bruix | 1896 | | |
| | | 8 | Chanzy | 1894 | | |
| | | 9 | Latouche-Tréville | 1895 | | |
| | Dupuy de Lôme | 1 10 | Dupuy de Lôme | 1895 |  | 6676t, 114.0x15.7x7.5m, 13b,2hte+1vte, 13000hp, 19.7kts, 526p; steel- 100belt, 20deck, 200turrets, 130CT; 2x1-194/45, 6x1-165/45, 4x1-65/50, 8x1-47/40, 8x5-37/20, 2-450TT |
| | Pothuau | 1 11 | Pothuau | 1897 | | 5374t, 113.0x15.3x6.5m, 18b,2vte, 10000hp, 19kts, 459p; NS- 60belt, 35deck, 170turrets, 230CT; 2x1-194/40, 10x1-139/45, 10x1-47/40, 8x1-37/20, 4- |

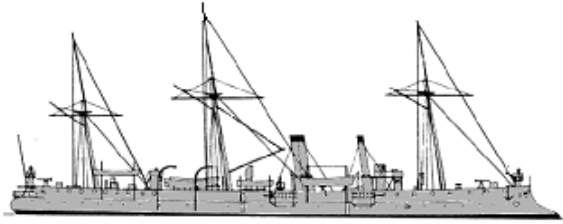
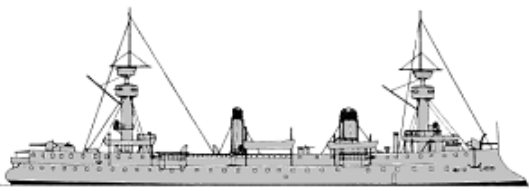
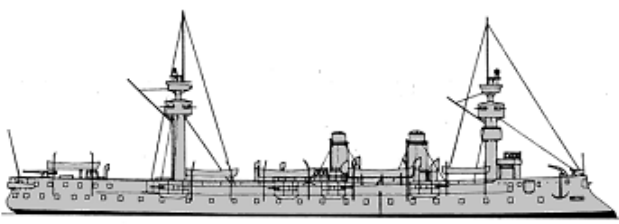
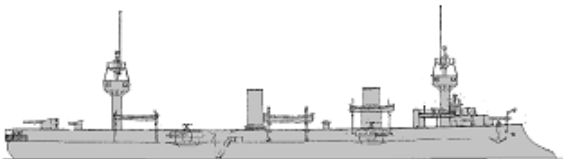
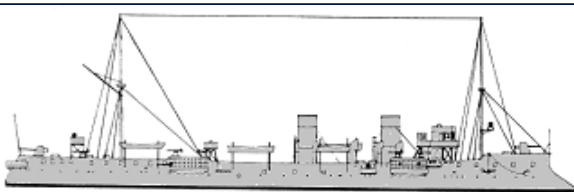
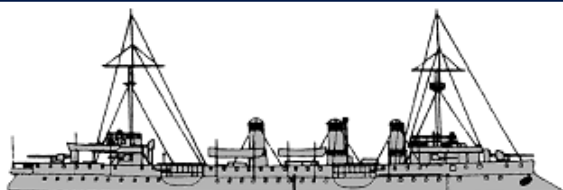
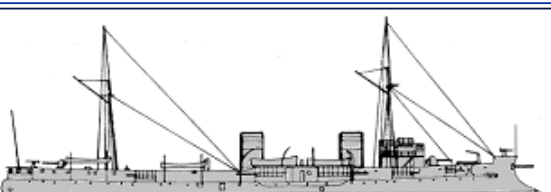
| | | | | | | |
|----------------|---|---|----------------|------|--|---|
| | | | | |  | 450TT |
| Sfax | 1 | 1 | Sfax | 1887 |  | 4561t, 91.6x15.0x7.7m, 12b,2hc, 6500hp, 16.7kts, 486p; steel- 60deck, 25CT; 6x1-165/28, 10x1-139/30, 6x1-47/40, (4x5+6x1)-37/20, 2-350TT |
| Forbin | 3 | 2 | Forbin | 1889 |  | 1935(2)-2012(3)-1901(4)t, 95.0x9.0x5.2m, 6b,2hc, 5800hp, 20-20.5kts, 199p; steel- 40deck, 20CT(3); 4x1-139/30, 3x1-47/40, 4x5-37/20, 4-350TT, 150mines |
| | | 3 | Surcouf | 1890 | | |
| | | 4 | Coëtlogon | 1894 | | |
| Tage | 1 | 5 | Tage | 1890 |  | 7469t, 118.9x16.3x7.7m, 12b,2hte, 12500hp, 19.2kts, 538p; steel- 55slopes, 50deck, 90CT; 8x1-165/30, 10x1-139/30, 5x1-47/40, 1x5-47/20, 14x5-37/20, 7-380TT |
| Amiral Cécille | 1 | 6 | Amiral Cécille | 1890 |  | 5839t, 115.5x15.0x6.8m, 12b,4vc(2), 10200hp, 19.4kts, 517p; steel- 100slopes, 55deck, 90CT; 8x1-165/30, 10x1-139/30, 6x1-47/40, 14x5-37/20, 4-380TT |
| Troude | 3 | 7 | Cosmao | 1891 | | 1923(7)-1968(8)-1994(9)t, 95.0x9.0x5.2m, 5b,2hc, 5800hp, 20.5kts, 201p; steel- 40deck, 25CT(8,9); 4x1-139/30, 10x1-47/40, 4x1-37/20, 150mines |
| | | 8 | Lalande | 1890 | | |
| | | 9 | Troude | 1891 | | |

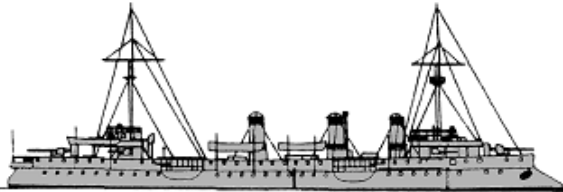
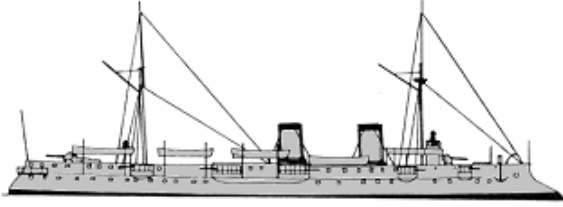
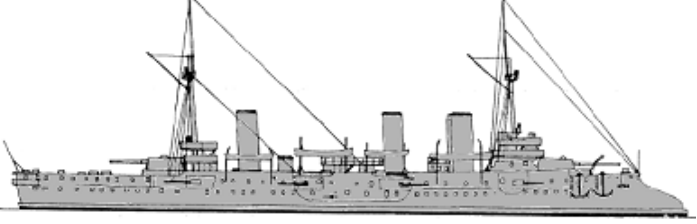
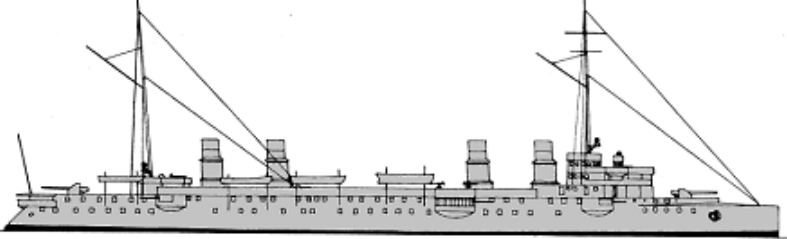
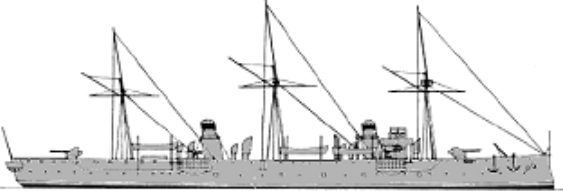
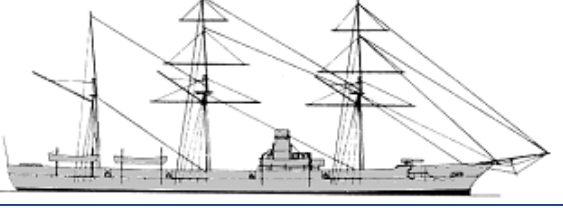

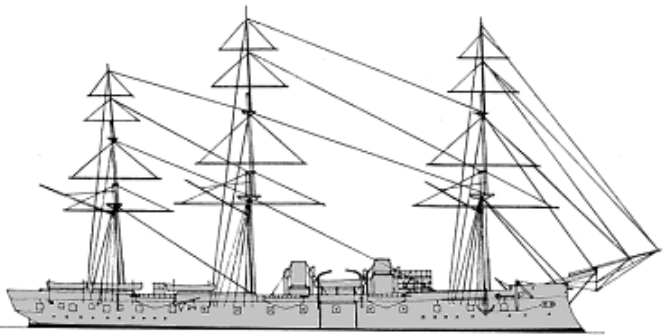
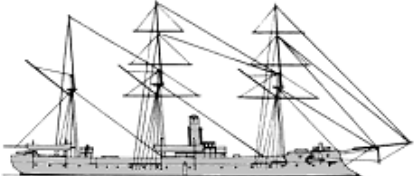
| | | | | | | |
|----------------------|--------|--------------|--------------|--|---|---|
| CL | | | |  | | |
| | Davout | 1 | 10 Davout | 1891 |  | 3031t, 88.0x12.0x6.6m, 8b,2ite, 9000hp, 20.7kts, 329p; steel- 100slopes, 50deck, 70CT; 6x1-165/30, 4x1-65/50, 4x1-47/40, 2x1-37/20, 6-350TT |
| | Alger | 3 | 11 Alger | 1891 |  | 4313(11)-4406(12)-4044(13)t, 107.0x13.0x6.1-6.5m, 24b,2vte(11)-8b,2hte(12,13), 8000hp, 19(11)-19.5(12,13)kts, 387(11)-405(12,13)p; steel- 100slopes, 50deck, 50shields(12,13), 50(11)-75(12,13)CT; 4x1-165/28, 6x1-139/30, 2x1-65/50, 8x1-47/40(11), 12x1-47/40(12,13), 8x5-37/20(11), 10x5-37/20(12,13), 5-350TT |
| | | | 12 Isly | 1893 | | |
| | | | 13 Jean Bart | 1891 | | |
| | Suchet | 1 | 14 Suchet | 1894 |  | 3362t, 97.0x12.0x6.1m, 24b,2hte, 9500hp, 20.4kts, 335p; steel- 100slopes, 80deck, 70CT; 6x1-165/30, 4x1-100/45, 8x1-47/40, 8x1-37/20, 7-350TT |
| | Linois | 3 | 15 Linois | 1895 |  | 2285(15)-2318(16,17)t, 98.0(15)-100.6(16,17)x10.6(15,17)-11.0(16)x5.4m, 6b,2vte(15)-16b,2vte(16,17), 6800hp, 20.5kts, 201p; steel- 40deck, 75shields, 125CT; 4x1-139/45, 2x1-100/45, 8x1-47/40, (4x5+2x1)-37/20, 4-450TT(15), 2-450TT(16,17), 120mines(15,16) |
| | | | 16 Galilée | 1897 | | |
| | | | 17 Lavoisier | 1898 | | |
| | Friant | 3 | 18 Friant | 1895 |  | 3982(18)-3824(19)-3809(20)t, 97.0x13.0x6.3m, 20b,2vte(18,19)-24b,2vte(20), 9500hp, 18.7kts, 339p; steel- 80slopes, 30deck, 50shields, 75CT; 6x1-165/45, 4x1-100/45, 4x1-47/40, 11x1-37/20, 2-350TT |
| 19 Chasseloup-Laubat | | | 1895 | | | |
| 20 Bugeaud | | | 1896 | | | |
| Descartes | 2 | 21 Descartes | 1896 |  | 3960t, 99.0x13.0x6.5m, 16b,2vte, 8500hp, 19.5kts, 383(21)-401(22)p; steel- 60slopes, 45deck, 50shields, 70CT; 4x1-165/45, 10x1-100/45, 8x1-47/40(21), 14x1-47/40(22), 4x1-37/20(21), 8x1-37/20(22), 2-450TT | |
| | | 22 Pascal | 1897 | | | |

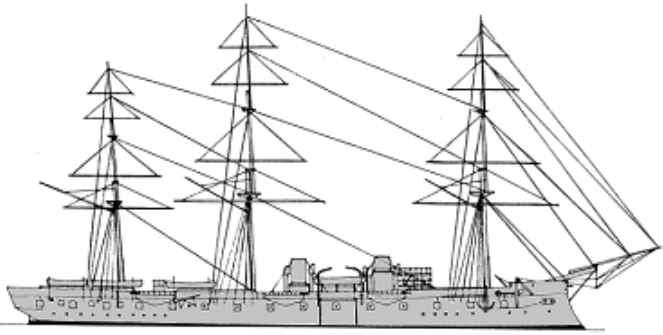
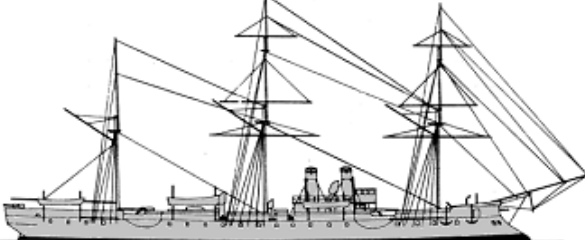

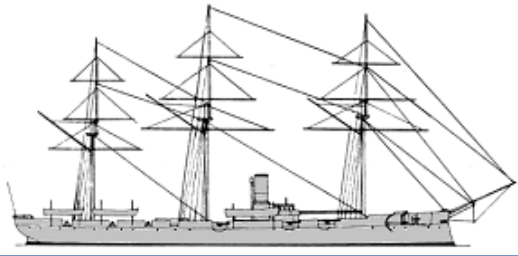
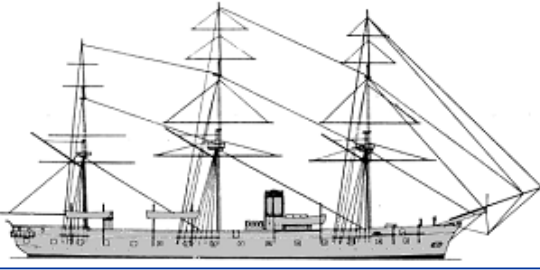
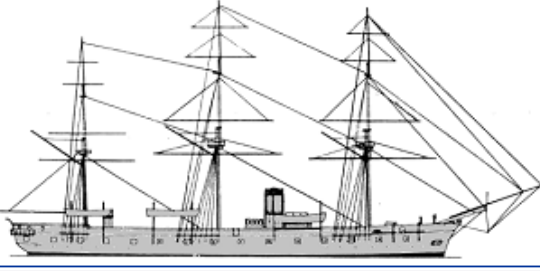
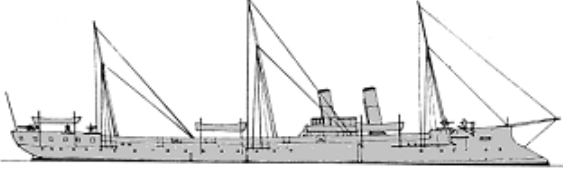
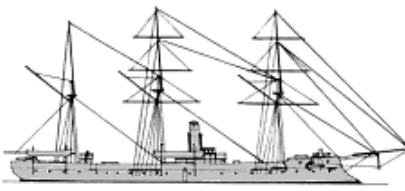
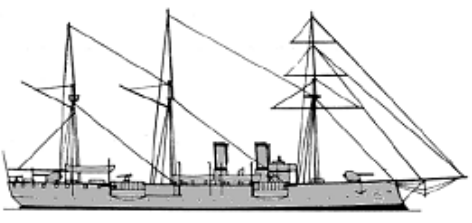



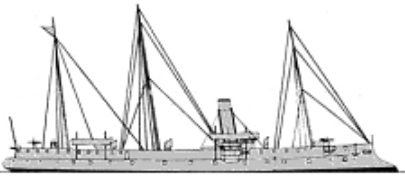
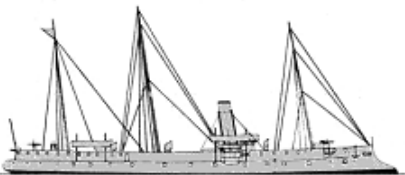

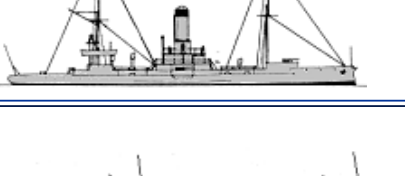
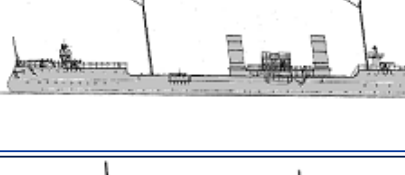
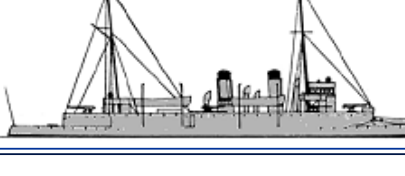
| | | | | | | |
|-----------------|---|----|-----------------|------|--|--|
| D'Assas | 3 | 23 | Cassard | 1898 |  | 3890(23,25)-3962(24)t, 99.0x13.7x6.3m, 20b,2vte, 10000hp, 20kts, 370-392p; 100slopes, 70deck, 50shields, 100CT; 6x1-165/45, 4x1-100/45, 10x1-47/40, 9x1-37/20(23,25), 5x1-37/20(24), 2-450TT |
| | | 24 | D'Assas | 1898 | | |
| | | 25 | Du Chayla | 1898 | | |
| Catinat | 2 | 26 | Catinat | 1898 |  | 4048(26)-4001(27)t, 101.0x13.6x6.4m, 16b,2vte, 9500hp, 19.5(26)-20(27)kts, 400p; steel- 60slopes, 45deck, 50shields, 70CT; 4x1-165/45, 10x1-100/45, 10x1-47/40, 4x1-37/20, 2-350TT, 50mines |
| | | 27 | Protet | 1899 | | |
| D'Entrecasteaux | 1 | 28 | D'Entrecasteaux | 1899 |  | 8142t, 120.0x17.8x7.5m, 5b,2vte, 14500hp, 19.2kts, 559p; Harvey- 100slopes, 55deck, 250turrets, 250CT; 2x1-240/40, 12x1-139/30, 12x1-47/40, 6x1-37/20, 6-450TT |
| Guichen | 1 | 29 | Guichen | 1899 |  | 8151t, 139.0x17.0x7.5m, 36b,3vte, 25000hp, 23.5kts, 604p; Harvey- 100slopes, 55deck, 60casemates, 160CT; 2x1-165/45, 6x1-139/45, 10x1-47/40, 5x1-37/20, 2-450TT |
| D'Estrées | 1 | 30 | D'Estrées | 1899 |  | 2428t, 95.0x12.0x5.4m, 8b,2vte, 8500hp, 20.5kts, 235p; steel- 43deck; 2x1-139/45, 4x1-100/45, 8x1-47/40, 2x1-37/20 |
| Infernet | 1 | 1 | Laclocheterie | 1874 |  | 2042t, 79.9x10.9x5.7m, 4b,1hc, 2000hp, 15kts, 205p; 10x1-139/21, 8x5-37/20 |
| | | | | | | |







| | | | | | | |
|-----|---|--------|-----------------|------|--|---|
| CLL | | | Tourville | 1877 |  | 5698t, 98.6x15.4x7.9m, 12b,1hc, 7460hp, 16.9kts, 540p; 7x1-165/28, 14x1-139/21, 1x1-90/36, 10x1-47/40, 8x5-37/20 |
| | | | Amiral Parseval | 1880 |  | 856t, 60.8x8.6x4.0m, 2b,1hc, 800hp, 11.4kts, 119p; 4x1-139/21, 5x5-37/20 |
| | | | Éclairer | 1879 |  | 1800t, 73.9x10.8x5.5m, 6b,1hc, 2400hp, 15kts, 194p; 8x1-139/21, 8x5-37/20 |
| | | | Duquesne | 1878 |  | 5905t, 100.4x15.2x8.0m, 12b,1hc, 8000hp, 16.8kts, 551p; 7x1-194/20, 14x1-139/21, 1x1-90/36, 11x1-47/40, 8x5-37/20 |
| | | | Duguay-Trouin | 1879 |  | 3479t, 89.8x13.2x6.3m, 8b,1hc, 4800hp, 15.5kts, 322p; 5x1-165/28, 5x1-139/21, 4x1-47/40, 5x5-37/20, 2-350TT |
| | | 7 | D'Estaing | 1881 | | |
| | 8 | Nielly | 1882 | | | |



| | | | | | | |
|------------|---|----|------------|------|--|--|
| Lapérouse | 3 | 9 | Primauguet | 1884 |  | 2363t, 81.9x11.4x5.7-5.9m, 6b,1hc, 2750hp, 15kts, 264p; 15x1-139/21, 1x1-90/36, (8-10)x5-37/20 |
| Naiade | 1 | 10 | Naiade | 1882 |  | 3637t, 74.4x14.3x7.2m, 8b,1hc, 2800hp, 14.7kts, 439p; 2x1-165/28, 18x1-139/21, 2x1-100/27, 8x5-37/20 |
| Iphigénie | 1 | 11 | Iphigénie | 1883 |  | 3346t, 73.2x14.2x6.8m, 6b,1hc, 2780hp, 14kts, 435p; 2x1-165/21, 18x1-139/21, 2x1-100/27, 8x5-37/20, 1-350TT |
| Milan | 1 | 12 | Milan | 1885 |  | 1705t, 92.1x10.0x4.8m, 12b,2hc, 4000hp, 18.4kts, 194p; 2x1-100/26, 12x1-47/40, 2-350TT |
| Inconstant | 3 | 13 | Inconstant | 1887 |  | 877(13,14)-898(15)t, 61.3x8.0x4.2m, 6b,1hc(13,15)-4b,1hc(14), 1100hp, 12(13,14)-13.8(15)kts, 116p; 3x1-139/30, 1x1-100/26, 5x5-37/20 |
| | | 14 | Papin | 1887 | | |
| | | 15 | Fulton | 1888 | | |
| Kersaint | 1 | 16 | Kersaint | 1898 |  | 1276t, 68.6x10.5x4.6m, 4b,1vte, 2400hp, 16kts, 146p; 1x1-139/45, 5x1-100/45, 7x1-37/20 |

TORPEDO SHIPS

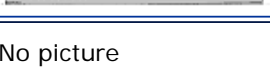

| | | | | | | | |
|-----|-------------|-------|---------|--------------|------|--|---|
| PGT | Condor | 4 | 1 | Condor | 1886 |  | 1229(1)-1268(2)-1311(3)-1266(4)t, 68.0ppx9.0x4.7m, 4b,2ic(1-3)-4b,2hc(4), 3000hp, 17.5(1)-17(2-4)kts, 137p; steel- 40deck; 5x1-100/26, 4x1-47/40, 6x5-37/20 |
| | | | 2 | Épervier | 1887 | | |
| | | | 3 | Faucon | 1887 | | |
| | | | 4 | Vautour | 1889 | | |
| | Wattignies | 2 | 5 | Wattignies | 1892 |  | 1280t, 68.0ppx8.9x4.8m, 4b,2hte(5)-8b,2hte(6), 4000hp, 18.5(5)-18(6)kts, 162(5)-173(6)p; steel- 40deck; 5x1-100/26, 6x1-47/40, 4x1-37/20 |
| | | | 6 | Fleurus | 1898 | | |
| | Bombe | 8 | 7 | Bombe | 1887 |  | 369-430t, 59.2ppx6.0x3.2m, 4b,2vc, 1800hp, 18-19kts, 70p; steel- 13CT; 2x1-47/40, 5x1- 37/20, 2x1-350TT |
| | | | 8 | Couleuvrine | 1887 | | |
| | | | 9 | Dague | 1888 | | |
| | | | 10 | Dragonne | 1888 | | |
| | | | 11 | Flèche | 1888 | | |
| | | | 12 | Lance | 1890 | | |
| | | | 13 | Sainte-Barbe | 1890 | | |
| | 14 | Salve | 1890 | | | | |
| | Lévrier | 2 | 15 | Léger | 1891 |  | 503t, 63.0x7.0x3.2m, 6b,2vte, 2400hp, 89p; 1x1-65/50, 3x1-47/40, 2x1-37/20, 2x1-450TT |
| | | | 16 | Lévrier | 1891 | | |
| | D'Iberville | 3 | 17 | D'Iberville | 1894 |  | 952(17)-970(18,19)t, 81.9x8.1(17)-8.2(18,19)x3.5m, 8b,2vqe(17,18)-8b,2vte(19), 5000hp, 21.5- 22kts, 143(17)-140(18,19)p; steel- 20belt(18,19), 40slopes(17), 20deck(18,19), 40CT(17); 1x1-100/45, 3x1-65/50, 6x1- 47/40(17), 7x1-47/40(18,19), 2x1- 450TT(18,19) |
| | | | 18 | Cassini | 1895 | | |
| | | | 19 | Casabianca | 1896 | | |
| | Dunois | 2 | 20 | Dunois | 1898 |  | 889t, 78.0x8.4x3.9m, 8b,2vte, 7500hp, 21.7- 22kts, 137p; steel- 25belt, 10deck, 50CT; 6x1- 65/50, 6x1-47/40 |
| 21 | | | La Hire | 1899 | | | |
| DD | Durandal | 2 | 1 | Durandal | 1899 |  | 296t, 57.6x6.3x3.2m, 2b,2vte, 4800hp, 26kts, 52p; 1x1-65/50, 6x1-47/40, 2x1-380TT |

| | | | | | | | |
|--------------|---------|----|--------------|--|--|---|---|
| | | | | | |  | |
| | | 2 | Hallebarde | 1899 | | | |
| TB | Balny | 9 | 1-9 | Balny, Déroulède, Doudart de la Grée, Edmond Fontaine, Bouet Willaumez, Dehorter, Capitaine Cuny, Capitaine Mehl, Challier | 1886 |  | 65t, 40.7x3.3x1.2m, 1b,1cr, 580hp, 19kts, 22p; 2x5-37/20, 2-350TT |
| | Coureur | 3 | 10 | Coureur | 1888 |  | 125(10)-131(11,12)t, 44.9(10)-45.1(11,12)x4.3(10)-4.4(11,12)x1.4m 2b,2vcr(10)-2b,2vte(11,12), 1500(10)-1750(11,12)hp, 23.5kts; 2x1-47/40, 2-350TT |
| | | | 11 | Véloce | 1892 | | |
| | | | 12 | Grondeur | 1892 | | |
| | Ouragan | 5 | 13 | Ouragan | 1889 |  | 177t, 46.7x4.8x1.8m, 2b,1vqe, 1400hp, 16kts, 29-32p; 2x1-47/40, 4x1-350TT |
| | | | 14 | Alarme | 1889 | | |
| | | | 15 | Téméraire | 1889 | | |
| | | | 16 | Aventurier | 1889 | | |
| | | | 17 | Défi | 1889 | | |
| | Agile | 6 | 18 | Agile | 1889 |  | 119(18-21)-129(22,23)t, 43.6(18- 21)-44.2(22,23)x4.6x1.1m, 1b,1vte(18)-2b,1vte(19-23), 1100hp, 27kts; 3x5-37/20, 3x1-350TT(18-20), (1+1x1)-380TT(21-23) |
| | | | 19 | Eclaire | 1891 | | |
| | | | 20 | Kabyle | 1892 | | |
| | | | 21 | Orage | 1892 | | |
| | | | 22 | Sarrazin | 1894 | | |
| | | | 23 | Tourbillon | 1894 | | |
| Avant-Garde | 6 | 24 | Archer | 1893 |  | 128(24)-127(25,26)-129(27-29)t, 42.0pp(24)-41.9pp(25-29)x4.5x1.3m, 2b,2cr(24)-2b,2vte(25-29), 1250(24)-1750(25- 29)hp, 20.5(24)-21(25-29)kts, 27p; 2x1-47/40, (1+1x1)-350TT | |
| | | 25 | Turco | 1892 | | | |
| | | 26 | Zouave | 1892 | | | |
| | | 27 | Dragon | 1892 | | | |
| | | 28 | Grenadier | 1892 | | | |
| | | 29 | Lancier | 1893 | | | |
| Corsaire | 1 | 30 | Corsaire | 1893 |  | 168t, 50.5x4.5x1.7m, 2b,2vte, 2500hp, 25.5kts; 2x5-37/20, 2x1-380TT | |
| Mousquetaire | 1 | 31 | Mousquetaire | 1893 |  | 123t, 48.0x4.7x1.3m, 2b,2vte, 2100hp, 24.5kts; 2x5-37/20, 2x1-450TT | |
| Chevalier | 1 | 32 | Chevalier | 1894 |  | 135t, 43.8x4.5x1.5m, 2b,2vte, 2200hp, 24.5kts; 2x5-37/20, 2x1-450TT | |

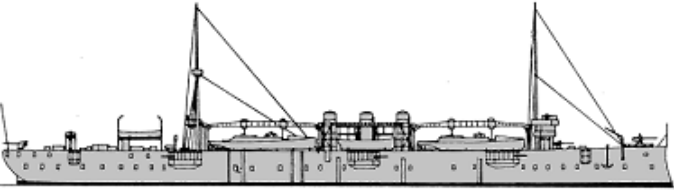

| | | | | | | | |
|------------|-------------|----|------------|-----------------------------|--|--|--|
| | Argonaute | 2 | 33 | Argonaute | 1894 |  | 129t, 42.9x4.5x1.7m, 2b,2vte, 2000hp, 23.5kts, 27p; 2x1-47/40, (1+1x1)-380TT |
| | | | 34 | Tourmente | 1894 | | |
| | Averne | 2 | 35 | Averne | 1894 |  | 131t, 43.9x4.6x1.3m, 2b,2vte, 1750hp, 23.5kts; 2x1-47/40, (1+1x1)-380TT |
| | | | | 36 | Dauphin | | |
| | Filibustier | 2 | 37 | Ariel | 1895 |  | 123t, 42.0x4.5x1.7m, 2b,2vte, 2000hp, 23.5kts; 2x1-47/40, (1+1x1)-380TT |
| | | | | 38 | Aquilon | | |
| | Forban | 1 | 39 | Forban | 1896 |  | 150t, 44.0x4.6x1.4m, 2b,2vte, 3260hp, 29kts, 29p; 2x1-37/20, 2x1-350TT |
| Mangini | 1 | 40 | Mangini | 1897 |  | 140t, 45.0ppx4.7x1.5m, 2b,2vte, 2100hp, 24kts, 27p; 2x1-47/40, (1+1x1)-380TT | |
| Lansquenet | 1 | 41 | Lansquenet | 1898 | No picture | 197t, 52.2x5.3x1.7m, 4b,2vte, 2500hp, 22kts; 2x5-37/20, 2x1-450TT | |
| Cyclone | 1 | 42 | Cyclone | 1899 |  | 150t, 46.4x4.7x1.5m, 2b,2vte, 4200hp, 29kts; 2x1-47/40, 1x2-380TT | |
| TB2cl | No22 | 7 | 1-7 | No37-40, 51-53 | 1879-1880 | No picture | 33t, 27.0x3.6x0.9m, 1b,1vcr, 320-500hp, 18kts; 2-350TT |
| | No24 | 8 | 8-15 | No24, 25, 33-36, 43, 44, 50 | 1879-1880 | No picture | 32-35t, 26.0x3.6x0.8m, 1b,1vcr, 320-500hp, 18kts; 2-350TT |
| | No20 | 2 | 16,17 | No54,55 | 1881 | No picture | 32-35t, 26.0x3.3x0.9m, 1b,1vcr, 320hp, 18kts; 2-350TT |
| | No26 | 1 | 18 | No26 | 1878 | No picture | 44t, 34.2x3.6x0.8m, 1b,1vcr, 500hp, 18kts, 11p; 2x5-37/20, 2x1-350TT |
| | No27 | 1 | 19 | No27 | 1879 | No picture | 43t, 31.8x3.3x0.9m, 1b,1vcr, 500hp, 18kts, 12p; 1x2-380TT |
| | No28 | 1 | 20 | No28 | 1879 | No picture | 43t, 34.5x3.7x0.8m, 1b,1vcr, 500hp, 18kts, 11p; 1x2-380TT |
| | No29 | 4 | 21-24 | No56-59 | 1881-1882 | No picture | 11(21,22)-9(23,24)t, 18.3x2.3x0.6m, 1b,1cr, 12kts, 12p; 1-350TT(21,22), 2-350TC(23,24) |
| | No31 | 2 | 25,26 | No31,32 | 1879 | No picture | 27t, 27.0x3.3x0.8m, 1b,1cr, 500hp, 19kts; 2-350TT |
| | No60 | 15 | 27-41 | No60-74 | 1882-1885 | No picture | 45t, 33.0x3.3x1.1m, 1b,1vcr, 500hp, 20kts, 11p; 4x5-37/20(35), 2-380TT(27-31), 2-350TT(32-35, 36-41) |
| | No75 | 51 | 42-92 | No75-125 | 1887-1889 | No picture | 53t, 35.0ppx3.4x0.9m, 1b,1vcr, 525hp, 20kts, 16p; 2x5-37/20, 2-380TT |
| | No126 | 4 | 93-96 | No126-129 | 1889-1890 | No picture | 78t, 36.0x3.9x1.2m, 1b,1vcr, 900hp, 21kts, 21p; 2x5-37/20, 2x1-380TT |
| | No130 | 14 | 97-110 | No130-132, 134-144 | 1890-1892 |  | 52t, 34.0ppx3.5x0.9m, 1b,1vte, 720hp, 20kts, 18p; 2x1-37/20, 1x1-380TT, 1spar torpedo |

| | | | | | | | |
|-----|--------|----|---------|---|-----------|--|--|
| | No145 | 25 | 111-135 | No145-149, 152-171 | 1891-1893 |  | 78t, 35.9ppx3.9x1.2m, 1b,1vte(111-124,134,135)-2b,1vte(125-133), 1000hp, 21kts, 22-23p; 2x5-37/20, (1+1x1)-380TT |
| | No172 | 29 | 136-164 | No172-200 | 1892-1895 |  | 78t, 35.9pp(136-155)-36.9pp(156-165)x3.9x1.2m, 2b,1vte(136-145,152-155)-1b,1vte(146-151,156-164), 1350hp, 22(136-158)-23(159-164)kts, 22-23p; 2x5-37/20, (1+1x1)-380TT |
| | A | 8 | 165-172 | A, B, D, E, F, G, H, I | 1894-1898 | No picture | 14t, 18.5x3.0x1.4m, 1b,1cr, 250hp, 17kts; 1-350TT |
| | C | 1 | 173 | C | 1894 | No picture | 14t, 19.0x2.9x1.5m, 1b,1vc, 20.5kts; 1-350TT |
| | No201 | 28 | 174-201 | No201-212, 216-222, 227, 230-234, 236-238 | 1897-1899 |  | 83-90t, 37.0x4.2x1.2m, 2b,1vte, 1500(174-184, 194-201)-1800(185-193)hp, 24kts, 23p; 2x5-37/20, (1+1x1)-380TT |
| CTB | Foudre | 1 | 1 | Foudre | 1897 |  | 6089t, 118.7x17.2x7.1m, 24b,2vte, 11500hp, 19kts, 410p Harvey- 120slopes, 60deck, 55shields, 120CT; 8x1-100/45, 4x1-65/50, 4x1-37/20, 10TBs |

SUBMARINES

| | | | | | | | |
|----|--------------|---|---|--------------|------|--|--|
| SS | Gymnôte | 1 | 1 | Gymnôte | 1888 |  | 32/33t, 18.4x1.8x1.7m, 1em, 90hp, 7.3/4.3kts, 5p, 20m; 2-350TC |
| | Gustave Zédé | 1 | 2 | Gustave Zédé | 1898 |  | 266/272t, 48.5x3.2x3.2m, 1em, 208hp, 19p, 30m; 1-450TT |

OTHER FIGHTING SHIPS

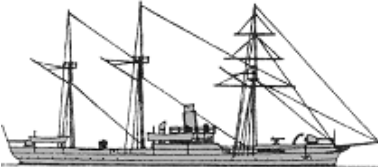

| | | | | | | | |
|----|-----------|---|----|------------|------|---|---|
| PG | Fusée | 4 | 1 | Flamme | 1887 |  | 1073-1124t, 50.3x9.9x3.2m, 3b,2vc, 1500hp, 12.5kts, 89p; compound(1,4)-steel(2,3)- 240belt, 50deck, 200barbette; 1x1-240/29, 1x1-90/28, 4x5-37/20 |
| | | | 2 | Fusée | 1885 | | |
| | | | 3 | Grenade | 1889 | | |
| | | | 4 | Mitraille | 1888 | | |
| | Achéron | 4 | 5 | Achéron | 1888 |  | 1690(5,6)-1767(7,8)t, 55.2(5,6)-58.7(7,8)x12.3x3.6m, 4b,2hc, 1600hp, 11.6-13kts, 110p; compound- 200belt, 50deck, 200turret; 1x1-274/29, 1x1-139/28(7,8), 2x1-100/26(5), 3x1-100/26(6), 2x1-47/40, 4x5-37/20(5,6), 7x5-37/20(7,8) |
| | | | 6 | Cocyte | 1890 | | |
| | | | 7 | Phlégéon | 1892 | | |
| | | | 8 | Styx | 1892 | | |
| | Crocodile | 3 | 9 | Aspic | 1880 |  | 465-492t, 44.1x7.3x2.9-3.3m, 2b,1hc, 440hp, 10-11kts, 76p; 2x1-139/21, 2x1-90/36, (2-4)x5-37/20 |
| | | | 10 | Capricorne | 1882 | | |
| | | | 11 | Vipère | 1881 | | |

| | | | | | | |
|-------------------|---|--------|-------------------|-----------|---|--|
| Comète | 5 | 12 | Comète | 1884 |  | 492t, 46.2ppx7.5x3.2m, 2b,1hc, 500hp, 11-12kts, 76p; 2x1-139/21, 2x1-100/27, 3x5-37/20 |
| | | 13 | Gabès | 1884 | | |
| | | 14 | Lion | 1884 | | |
| | | 15 | Météore | 1885 | | |
| | | 16 | Scorpion | 1884 | | |
| Gabriel Charmes | 1 | 17 | Gabriel Charmes | 1886 | No picture | 73t, 41.9x3.8x2.0m, 1b.1vc, 580hp, 19kts, 23p; 1x1-139/30 |
| Surprise | 2 | 18 | Surprise | 1896 |  | 617-637t, 56.0-56.3ppx7.9-8.0x3.7m, 2b,1hte, 900hp, 13kts, 99p; 2x1-100/45, 4x1-65/50, 4x1-37/20 |
| | | 19 | Décidée | 1898 | | |
| Javelot | 1 | 1 | Javelot | 1866 | No picture | 89t, 24.8x4.9x1.4m, 2, 45hp, 26p; 1x1-139/17, 1x1-47/40 |
| Berthe-de-Villers | 5 | 2 | Berthe-de-Villers | 1884 | No picture | 200t, 37.4x7.4x0.9m, w, 36hp, 51p; 2x1-90/28, 4x5-37/20 |
| | | 3 | Jacquín | 1884 | | |
| | | 4 | Garnier | 1884 | | |
| | | 5 | Henri-Rivière | 1884 | | |
| | | 6 | Moulun | 1884 | | |
| Estoc | 3 | 7 | Estoc | 1884 | No picture | 112t, 30.0x5.8x1.1m, 2, 45(7)-35(8,9)hp, 49p; 2x1-90/28, 3x5-37/20 |
| | | 8 | Mutine | 1884 | | |
| | | 9 | Rafale | 1884 | | |
| Niger | 2 | 10, 11 | Niger, Mage | 1884-1888 | No picture | 25t; 2x1-37/20 |
| Doucet | 5 | 12 | Bobillot | 1885 | No picture | 120t, 29.6x11.0x0.8m, w, 48p; 1x1-47/40, 4x5-37/20 |
| | | 13 | Cuvellier | 1885 | | |
| | | 14 | Doucet | 1885 | | |
| | | 15 | Raynaud | 1885 | | |
| | | 16 | Rollandes | 1885 | | |
| Opale | 2 | 17, 18 | Opale, Onyx | 1892-1893 | No picture | 60t, 34p; 2x1-37/20 |

[home](#)[World navies yesterday](#)[1900](#)

Germany 01 January 1900

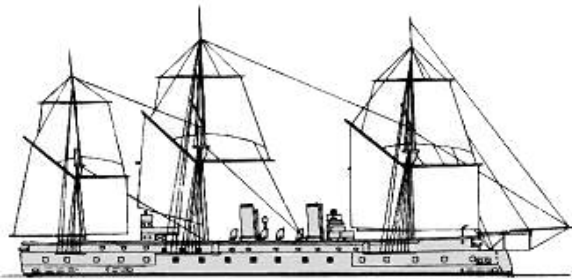
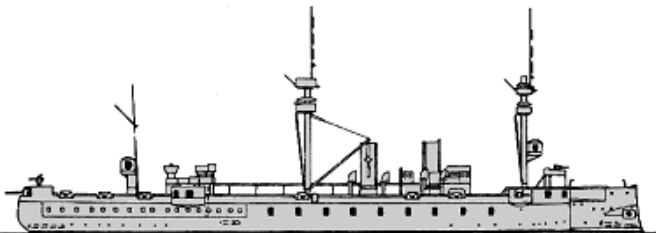
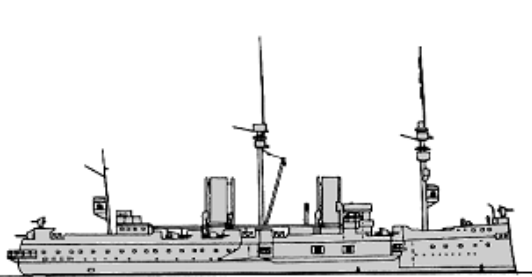
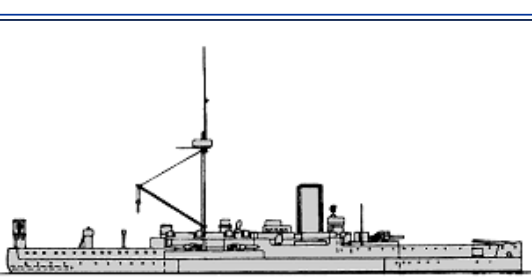
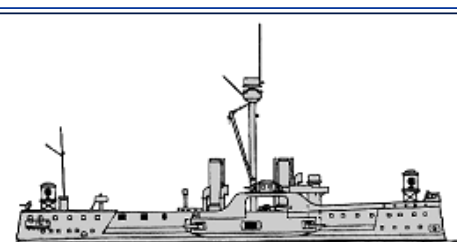
BATTLESHIPS

| | | | | | | |
|----|---------|---|-------------|------|--|---|
| | | | | |  | 6760t, 89.4x15.2x7.9m, 8b,1hse, 4870hp, 14.7kts, 541p; iron; 124belt, 121battery, 50CT; 2x1-209/20, 14x1-209/17, 6x5-37/20, 5-350TT |
| | | | | |  | 10761t, 112.2x18.3x8.6m, 8b,1hse, 8440hp, 14.7kts, 730p; iron; 305belt, 51deck, 203battery, 100CT; 22x1-238/18, 1x1-149/28, 18x1-88/27, 5-350TT |
| | | | | |  | 8940t, 89.3x19.1x7.9m, 8b,1hse, 5700hp, 14.5kts, 656p; steel; 254belt, 51deck, 203casemate, 50(3)-100(4)CT; 1x1-149/28(3), 8x1-149/32(4), 6x1-105/32(3), 9x1-88/27(3), 8x1-88/27(4), 4x1-37/42, 5-350TT |
| | | | | | | |
| BB | Sachsen | 5 | Sachsen | 1878 |  | 7742-7938t, 98.2x18.4x6.5m, 8b,2hc, 6201-6454hp, 14.2-15.7kts, 317p; 254belt, 75deck, 254barbettes/citadel, 200CT; 6x1-263/20, 8x1-88/27, 6x1-87/22, 8x5-37/20, 2-450TT, 3-350TT |
| | | 6 | Bayern | 1881 | | |
| | | 7 | Württemberg | 1881 | | |
| | | 8 | Baden | 1883 | | |
| | | | | |  | 5743t, 79.8x18.0x6.3m, 8b,2hc, 3942hp, 13.8kts, 389p; compound; 300belt, 30deck, 200battery, 50CT; 8x1-238/28, 4x1-149/20, 6x1-50/37, 4-350TT |
| | | | | |  | 10670t, 115.7x19.5x7.9m, 12b,2vte, 10000hp, 16.5kts, 568p; compond(10,12); 400belt, 60deck, 300barbettes, 300CT; 2x2-283/37, 1x2- |
| | | | | | | |
| | | | | | | |

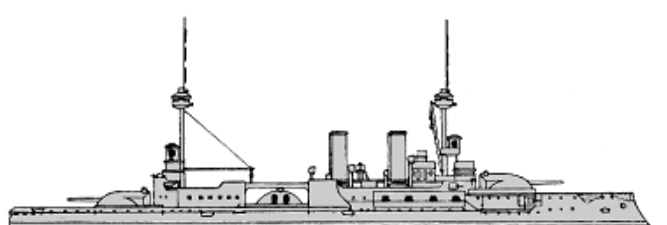
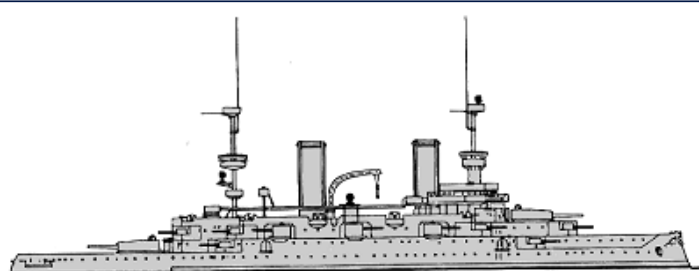
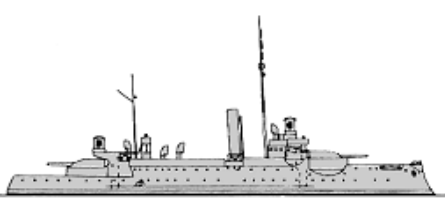
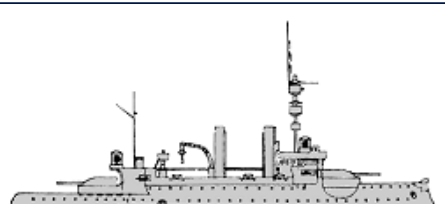
| | | | | | | | |
|----|----------------------|----|-------|----------------------|---|--|--|
| | | | | |  | | |
| | | 13 | Würth | 1893 | | 283/32, 6x1-105/32, 8x1-99/27, 6-450TT | |
| | Kaiser Friedrich III | 1 | 14 | Kaiser Friedrich III | 1898 |  | 11785t, 125.3x20.4x8.3m, 12b,3vte, 13000hp, 17.5kts, 651p; 300belt, 65deck, 250turrets, 250CT; 2x2-238/37, 18x1-150/37, 12x1-88/27, 6-450TT |
| BC | Siegfried | 6 | 1 | Siegfried | 1890 |  | 3741t, 79.0x14.9x5.7m, 4b,2vte, 5000hp, 14.5kts, 276p; compound; 240belt, 30deck, 200barbettes, 80CT; 3x1-238/32, 8x1-88/27, 4-350TT |
| | | | 2 | Beowulf | 1892 | | |
| | | | 3 | Frithjof | 1893 | | |
| | | | 4 | Heimdall | 1894 | | |
| | | | 5 | Hildebrand | 1893 | | |
| | | | 6 | Hagen | 1894 | | |
| | Odin | 2 | 7 | Odin | 1896 |  | 3750t, 79.0x15.2x5.6m, 8b,2vte, 4650(7)-5120(8)hp, 14.4(7)-15(8)kts, 276p; 220belt, 70deck, 200barbettes, 120CT; 3x1-238/32, 10x1-88/27, 3-450TT |
| | | | 8 | Agir | 1896 | | |



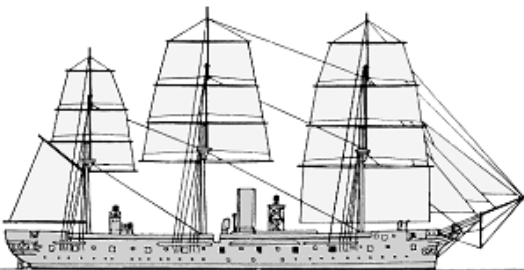
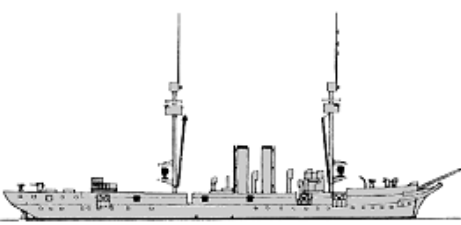
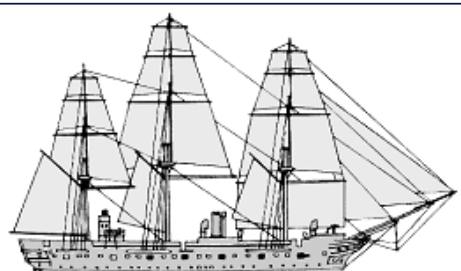

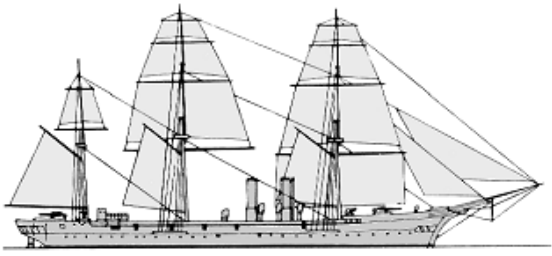
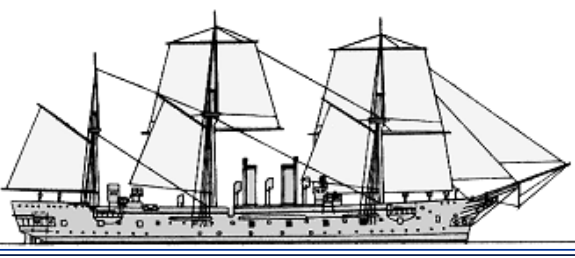
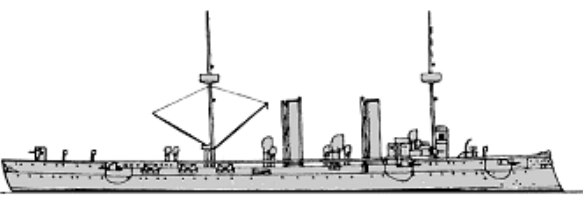
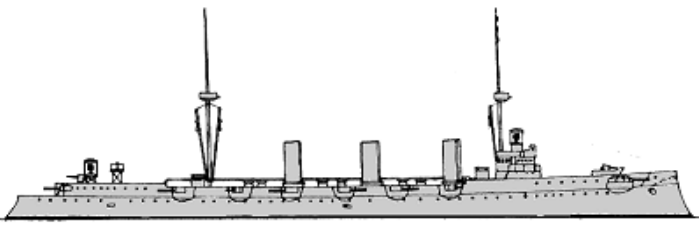
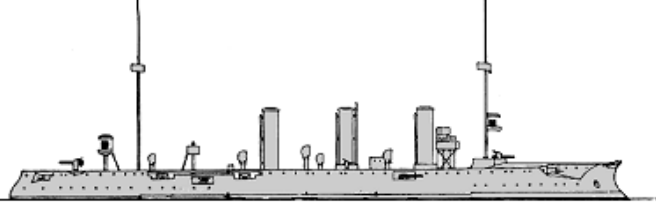
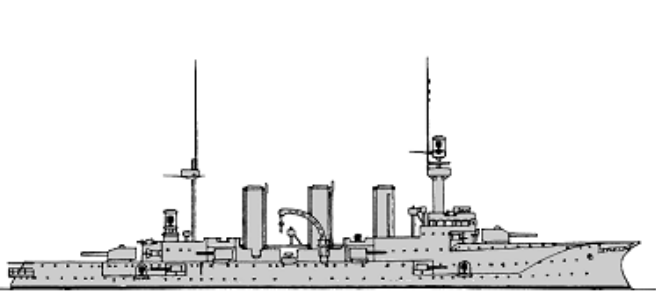
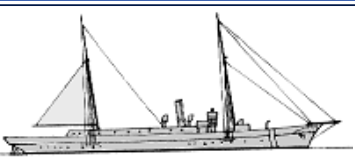
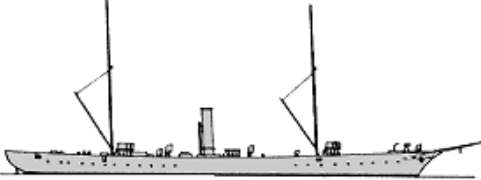

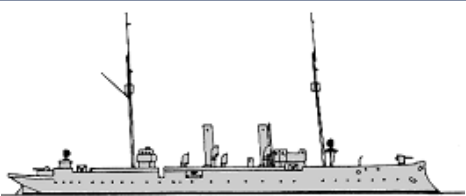
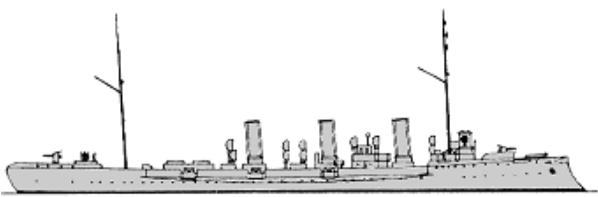
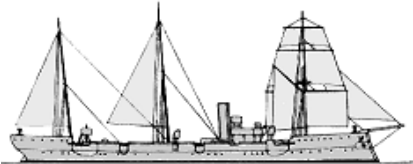
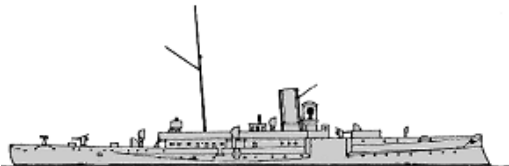
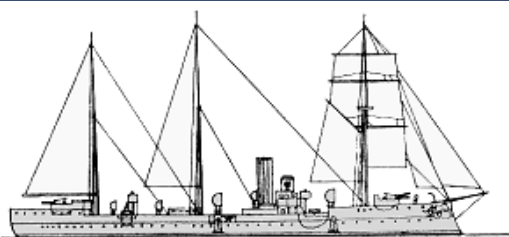
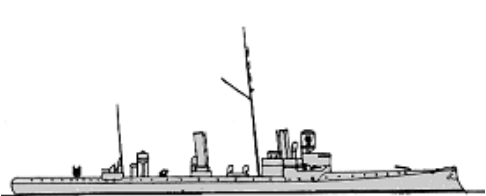
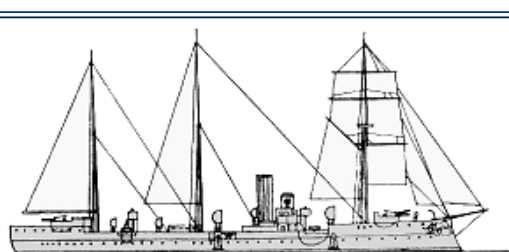
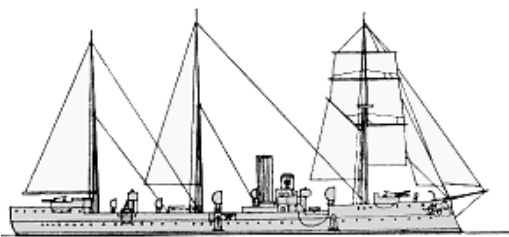
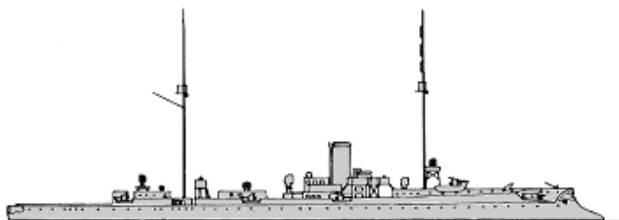

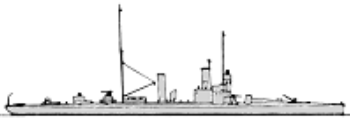

CRUISERS

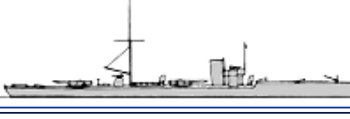

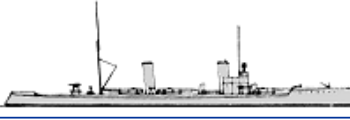
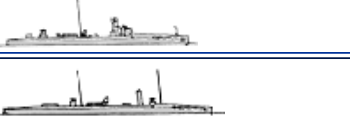



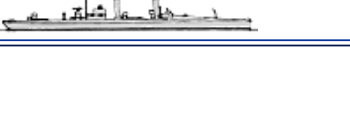

| | | | | | | |
|----------|---|----|-------------|------|--|--|
| Bismarck | 5 | 1 | Blücher | 1878 |  | 3386(1)-2994(2-5)t, 82.5(1)-82.0(2-5)x13.7x6.3m, 4b,1hse, 2500hp, 12.5kts, 404p; 10x1-149/22(2,3), 14x1-149/22(4), 12x1-149/22(5), 2x1-88/27(2-5), 4x1-87/24(1), 13x5-37/20(1), 6x5-37/20(2-5), 3-450TT(1), 4-350TT(1) |
| | | 2 | Stosch | 1878 | | |
| | | 3 | Moltke | 1878 | | |
| | | 4 | Gneisenau | 1880 | | |
| | | 5 | Stein | 1880 | | |
| Carola | 4 | 6 | Carola | 1881 |  | 2424t, 76.4x12.5x6.1m, 8b,1hc(6,7)-6b,1hc(8,9), 2100hp, 13.5kts, 269p; 6x1-149/20(6), 10x1-149/20(8,9), 2x1-105/32(6), 8x1-88/27(6,8,9), 2x1-87/22(7), 2x1-50/37(6), 10x5-37/20(8,9) |
| | | 7 | Olga | 1881 | | |
| | | 8 | Marie | 1882 | | |
| | | 9 | Sophie | 1882 | | |
| Nixe | 1 | 10 | Nixe | 1886 |  | 1982t, 63.3x13.2x6.4m, 2b,1hc, 700hp, 9kts, 358p; 6x1-125/21, 2x1-88/27, 4x5-37/20 |
| | | 11 | Alexandrine | 1886 | | |

| | | | | | | | |
|--------|------------------|---|--------|------------------|--|--|--|
| CL | Alexandrine | 2 | 12 | Arcona | 1886 |  | 2662t, 81.2x12.6x6.3m, 8b,1hc, 2400hp, 14kts, 282p; 10x1-149/27, 4x1-105/32, 6x5-37/20 |
| | Charlotte | 1 | 13 | Charlotte | 1886 |  | 3763t, 83.9x14.6x6.9m, 8b,1hc, 3000hp, 13kts, 506p; 2x1-105/32, 16x1-88/27, 4x5-37/20 |
| | Irene | 2 | 14 | Irene | 1888 |  | 5027t, 103.7x14.2x7.6m, 4b,2hc, 8000hp, 18kts, 365p; compound; 75slopes, 50deck, 50CT; 4x1-149/28, 8x1-105/32, 6x1-50/37, 3-350TT |
| | | | 15 | Prinzess Wilhelm | 1889 | | |
| | Kaiserin Augusta | 1 | 16 | Kaiserin Augusta | 1892 |  | 6381t, 123.2x15.6x7.4m, 8b,3vte, 12000hp, 21kts, 430p; 70slopes, 50deck, 50CT; 14x1-149/32, 8x1-88/27, 4x5-37/20, 5-350TT |
| | Gefion | 1 | 17 | Gefion | 1894 |  | 4275t, 110.4x13.2x6.5m, 6b,2vte, 9000hp, 19kts, 212p; steel; 25slopes, 30deck, 30CT; 10x1-105/32, 6x1-50/37, 2x1-450TT |
| | Victoria Louise | 5 | 18 | Victoria Louise | 1899 |  | 6491(18-20)-6705(21,22)t, 110.6x17.4(18-20)-17.6(21,22)x6.8-7.3m, 12b,3vte(18-21)-18b,3vte(22), 10000hp, 19.5(18-20)-18.5(21,22)kts, 477p; 100slopes, 40deck, 100turrets, 150CT; 2x1-209/37, 8x1-149/37, 10x1-88/27, 3-450TT |
| 19 | | | Hertha | 1898 | | | |
| 20 | | | Freya | 1898 | | | |
| 21 | | | Vineta | 1899 | | | |
| 22 | | | Hansa | 1899 | | | |
| Grille | 1 | 1 | Grille | 1858 |  | 491t, 56.9x7.4x3.2m, 2b,1hc, 760hp, 14.4kts, 70p; 1x1-125/21, 2x1-79/25, 6x5-37/20 | |
| Zieten | 1 | 2 | Zieten | 1876 |  | 1170t, 79.4x8.6x4.6m, 6b,2hc, 2000hp, 16kts, 94p; 6x1-50/37 | |
| | | 3 | Blitz | 1883 | | 1486t, 78.4x9.9x4.4m, 8b,2hc, 2700hp, | |

| | | | | | | | |
|----------|----------|----|----------|----------|--|--|--|
| CLL | Blitz | 2 | 4 | Pfeil | 1884 |  | 15.6kts, 134p; 6x1-88/27, (2x1+1)-350TT |
| | Greif | 1 | 5 | Greif | 1887 |  | 2266t, 102.6x9.8x4.3m, 6b,2hc, 5400hp, 18kts, 170p; 2x1-105/32, 8x1-88/27, 6x5-37/20 |
| | Schwalbe | 2 | 6 | Schwalbe | 1888 |  | 1359t, 66.9x9.4x4.7m, 4b,2hc, 1500hp, 13.5kts, 117p; 8x1-105/32, 5x5-37/20 |
| | | | 7 | Sperber | 1889 | | |
| | Wacht | 2 | 8 | Wacht | 1888 |  | 1499t, 85.5x9.7x4.7m, 4b,2dte, 4000hp, 19kts, 141p; compound; 40slopes, 20deck, 25CT; 4x1-88/27, 3-350TT |
| | | | 9 | Jagd | 1889 | | |
| | Bussard | 2 | 10 | Bussard | 1890 |  | 1868t, 82.6x10.2x5.6m, 4b,2hte, 2800hp, 15.5kts, 161p; 8x1-105/32, 2x1-350TT |
| | | | 11 | Falke | 1891 | | |
| | Meteor | 2 | 12 | Meteor | 1891 |  | 1078(12)-1117(13)t, 79.9x9.6x4.5m, 4b,2vte, 4500(12)-5000(13)hp, 19(12)-19.5(13)kts, 115p; steel; 25slopes, 15deck, 30CT; 4x1-88/27, 3-350TT |
| | | | 13 | Comet | 1893 | | |
| Seeadler | 3 | 14 | Seeadler | 1892 |  | 1864t, 82.6x10.5x5.4m, 4b,2hte, 2800hp, 15.5kts, 161p; 8x1-105/32, 2x1-350TT | |
| | | 15 | Condor | 1892 | | | |
| | | 16 | Cormoran | 1893 | | | |
| Geier | 1 | 17 | Geier | 1895 |  | 1918t, 83.9x10.6x5.2m, 4b,2hte, 2880hp, 15.5kts, 161p; 8x1-105/32, 2x1-450TT | |
| Hela | 1 | 18 | Hela | 1896 |  | 2082t, 105.0x11.0x4.6m, 6b,2vte, 6000hp, 20kts, 178p; steel; 25slopes, 20deck, 30CT; 4x1-88/27, 6x1-50/37, (1+2x1)-450TT | |

TORPEDO SHIPS

| | | | | | | | |
|------------|-----|-------|------------|------|---|---|---|
| DD | D1 | 2 | 1 | D1 | 1887 |  | 300t, 56.1x6.6x3.4m, 2b,1vte, 2000hp, 20.6kts, 46p; 3x1-50/37, (1+2x1)-350TT |
| | | | 2 | D2 | 1887 | | |
| | D3 | 2 | 3 | D3 | 1888 |  | 300t, 57.6x6.8x3.2m, 2b,1vte, 2200hp, 20.3kts, 46p; 3x1-50/37, (1+2x1)-350TT |
| | | | 4 | D4 | 1888 | | |
| | D5 | 2 | 5 | D5 | 1889 |  | 406t, 59.6x7.4x3.5m, 2b,1vte, 3200hp, 22.6kts, 46p; 3x1-50/37, (1+2x1)-350TT |
| | | | 6 | D6 | 1889 | | |
| | D7 | 2 | 7 | D7 | 1891 |  | 410t, 59.7x7.4x3.4m, 2b,1vte, 3600hp, 22.5kts, 46p; 3x1-50/37, (1+2x1)-450TT |
| | | | 8 | D8 | 1891 | | |
| | D9 | 1 | 9 | D9 | 1894 |  | 458t, 63.0x7.7x3.7m, 3b,1vte, 4200hp, 23.5kts, 52p; 3x1-50/37, (1+2x1)-450TT |
| | D10 | 1 | 10 | D10 | 1898 |  | 371t, 66.1x6.0x2.4m, 3b,2vte, 5783hp, 27.2kts, 47p; 5x1-50/37, (1+2x1)-450TT |
| S90 | 1 | 11 | S90 | 1899 |  | 394t, 63.0x7.0x2.8m, 3b,2vte, 5900hp, 27kts, 57p; 3x1-50/37, 3x1-450TT | |
| Nr. XVIII | 8 | 1-8 | V1, 2, 4-9 | 1884 |  | 61t, 32.8x3.8x1.8m, 1b,1vte, 590hp, 17.9kts, 14p; 2x5-37/20, 2-350TT | |
| Nr. XXVIII | 1 | 9 | S2 | 1884 |  | 99t, 37.7x4.9x2.2m, 1b,1vte, 970hp, 19.3kts, 15p; 2x5-37/20, (2+1x1)-350TT | |
| S7 | 17 | 10-26 | S7-23 | 1885 |  | 98t, 37.7x4.9x2.2m, 1b,1vte, 725hp, 20.4kts, 16p; 1x1-50/37, (1+2x1)-350TT | |
| S24 | 7 | 27 | S24 | 1886 |  | 103t, 37.7x4.8x2.3m, 1b,1vte, 840hp, 19.1kts, 16p; 1x1-50/37, (1+2x1)-350TT | |
| | | 28 | S25 | 1886 | | | |
| | | 29 | S27 | 1886 | | | |
| | | 30 | S28 | 1886 | | | |
| | | 31 | S29 | 1886 | | | |
| | | 32 | S30 | 1887 | | | |
| | | 33 | S31 | 1887 | | | |
| S32 | 1 | 34 | S32 | 1886 |  | 119t, 39.1x5.3x2.5m, 1b,1vte, 900hp, 19.9kts, 20p; 1x1-50/37, (1+2x1)-350TT | |
| S33 | 8 | 35 | S33 | 1887 |  | 113t, 39.9x4.8x2.3m, 1b,1vte, 1100hp, 20kts, 16p; 1x1-50/37, (1+2x1)-350TT | |
| | | 36 | S34 | 1887 | | | |
| | | 37 | S35 | 1887 | | | |
| | | 38 | S36 | 1887 | | | |
| | | 39 | S37 | 1887 | | | |
| | | 40 | S38 | 1887 | | | |
| | | 41 | S39 | 1887 | | | |
| | | 42 | S40 | 1887 | | | |
| S42 | 1 | 43 | S42 | 1889 |  | 153t, 44.2x5.0x2.6m, 1b,1vte, 1420hp, 22.2kts, 16p; 1x1-50/37, (1+2x1)-350TT | |
| | | 44 | S43 | 1889 |  | | |
| | | 45 | S44 | 1889 | | | |
| | | 46 | S45 | 1889 | | | |





| | | | | | | | |
|-----|------|------|-----|------|---|---|--|
| TB | S43 | 14 | 47 | S46 | 1889 |  | 152t, 44.2x5.0x2.7m, 1b,1vte, 1571hp, 21.5kts, 16p; 1x1-50/37, (1+2x1)-350TT |
| | | | 48 | S47 | 1889 | | |
| | | | 49 | S49 | 1890 | | |
| | | | 50 | S50 | 1890 | | |
| | | | 51 | S51 | 1890 | | |
| | | | 52 | S52 | 1890 | | |
| | | | 53 | S53 | 1890 | | |
| | | | 54 | S54 | 1890 | | |
| | | | 55 | S55 | 1890 | | |
| | | | 56 | S56 | 1890 | | |
| 57 | S57 | 1890 | | | | | |
| S58 | 8 | 58 | S58 | 1892 |  | 152t, 44.3x5.0x2.6m, 1b,1vte, 1232hp, 20.2kts, 16p; 1x1-50/37, (1+2x1)-350TT | |
| | | 59 | S59 | 1892 | | | |
| | | 60 | S60 | 1892 | | | |
| | | 61 | S61 | 1892 | | | |
| | | 62 | S62 | 1892 | | | |
| | | 63 | S63 | 1892 | | | |
| | | 64 | S64 | 1892 | | | |
| 65 | S65 | 1892 | | | | | |
| S66 | 1 | 66 | S66 | 1893 |  | 172t, 47.9x5.4x2.7m, 2b,1vte, 1610hp, 22.1kts, 24p; 1x1-50/37, (1+2x1)-450TT | |
| S67 | 7 | 67 | S67 | 1893 |  | 166t, 47.9x5.4x2.6m, 1b,1vte, 1600hp, 21.9kts, 24p; 1x1-50/37, (1+2x1)-450TT | |
| | | 68 | S68 | 1893 | | | |
| | | 69 | S69 | 1893 | | | |
| | | 70 | S70 | 1893 | | | |
| | | 71 | S71 | 1893 | | | |
| | | 72 | S72 | 1893 | | | |
| 73 | S73 | 1894 | | | | | |
| S74 | 1 | 74 | S74 | 1895 |  | 186t, 49.9x5.5x2.8m, 2b,1vte, 2500hp, 23.7kts, 24p; 1x1-50/37, (1+2x1)-450TT | |
| S75 | 7 | 75 | S75 | 1895 |  | 180t, 49.0x5.3x2.9m, 2b,1vte, 1744hp, 22.3kts, 24p; 1x1-50/37, (1+2x1)-450TT | |
| | | 76 | S76 | 1895 | | | |
| | | 77 | S77 | 1895 | | | |
| | | 78 | S78 | 1895 | | | |
| | | 79 | S79 | 1895 | | | |
| | | 80 | S80 | 1895 | | | |
| 81 | S81 | 1896 | | | | | |
| S82 | 6 | 82 | S82 | 1897 |  | 170t, 48.2x5.1x2.6m, 2b,1vte, 2146hp, 25.3kts, 29p; 1x1-50/37, (1+2x1)-450TT | |
| | | 83 | S83 | 1897 | | | |
| | | 84 | S84 | 1897 | | | |
| | | 85 | S85 | 1898 | | | |
| | | 86 | S86 | 1898 | | | |
| | | 87 | S87 | 1898 | | | |
| G88 | 2 | 88 | G88 | 1898 |  | 177t, 48.7x5.0x2.8m, 2b,1vqe, 2468hp, 26kts, 29p; 1x1-50/37, (1+2x1)-450TT | |
| | | 89 | G89 | 1898 | | | |
| TSS | Ulan | 1 | 1 | Ulan | 1876 |  | 438t, 38.0x8.0x4.6m, 4b,1vse, 800hp, 12kts, 41p; 3x5-37/20, 1-381TT |

ESCORTS

| | | | | | | | |
|----|--------|---|-----|------------------------------|-----------|--|--------------------------------------|
| PC | Sirius | 4 | 1-4 | Sirius, Vega, Castor, Pollux | 1889-1890 | | 52t, 22.6x4.6x1.6m, 1b,1vte, 200hp,, |
|----|--------|---|-----|------------------------------|-----------|--|--------------------------------------|

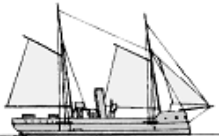
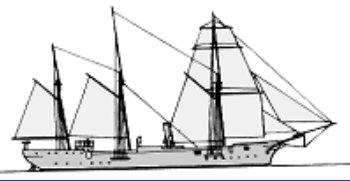
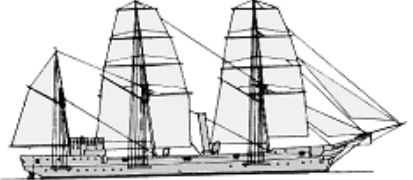

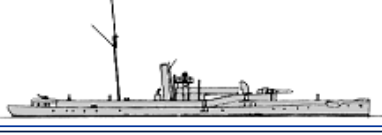
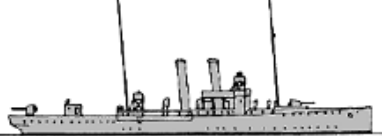
OTHER FIGHTING SHIPS

| | | | | | | |
|---------|----|----|------------|------|---|---|
| Wespe | 11 | 1 | Wespe | 1876 |  | 1163t, 46.4x10.6x3.4m, 4b,2dc, 700hp, 10kts, 88p; iron- 203belt, 40deck, 203barbette, 20CT; 1x1-305/20, 2x1-87/22, 2x5-37/20, 2-350TT |
| | | 2 | Viper | 1877 | | |
| | | 3 | Biene | 1877 | | |
| | | 4 | Mücke | 1878 | | |
| | | 5 | Scorpion | 1877 | | |
| | | 6 | Basilisk | 1880 | | |
| | | 7 | Camaeleon | 1879 | | |
| | | 8 | Crocodill | 1880 | | |
| | | 9 | Salamander | 1880 | | |
| | | 10 | Natter | 1881 | | |
| | | 11 | Hummel | 1881 | | |
| Otter | 1 | 12 | Otter | 1878 |  | 164t, 31.0x6.2x1.6m, 1b,2vse, 140hp, 8kts, 43p; small arms |
| Wolf | 2 | 13 | Wolf | 1878 |  | 570t, 47.2x7.7x3.4m, 2b,1hse, 340hp, 8.5kts, 106p; 2x1-125/21(14), 1x1-87/22(13), 2x1-87/22(14), 1x1-50/37(13), 2x5-37/20(13), 3x5-37/20(14) |
| | | 14 | Hyäne | 1879 | | |
| Habicht | 2 | 15 | Habicht | 1880 |  | 1005t, 59.2x8.9x4.2m, 2b,1hc, 600hp, 11kts, 127p; 5x1-125/21(15), 2x1-125/21(16), 5x5-37/20 |
| | | 16 | Möwe | 1880 | | |
| Hay | 1 | 17 | Hay | 1882 |  | 247t, 34.0x6.4x2.8m, 2b,1vc, 202hp, 9.3kts, 40p; 2x1-88/27 |
| Brummer | 2 | 18 | Brummer | 1884 |  | 929t, 64.8x8.5x4.8m, 2b,1dc, 1658(18)-2081(19)hp, 14.1(18)-15.2(19)kts, 78p; compound- 160breastwork, 40deck; 1x1-209/28, 1x1-87/22, 2x5-37/20, 1-350TT |
| | | 19 | Bremse | 1884 | | |
| Iltis | 2 | 20 | Iltis | 1898 |  | 1031t, 65.2x9.1x3.6m, 4b,2hte, 1300hp, 14.5kts, 130p; 4x1-88/27 |
| | | 21 | Jaguar | 1899 | | |
| APG - | 1 | 1 | Lorelei | 1886 |  | 924t |

MINE WARFARE SHIPS

| | | | | | | |
|-------|---|---|-------|------|---|---|
| Rhein | 1 | 1 | Rhein | 1867 |  | 482t, 47.1x6.0x3.2m, 1b,1vse, 200hp, 9kts, 81p; 2x5-37/20, 100mines |
|-------|---|---|-------|------|---|---|

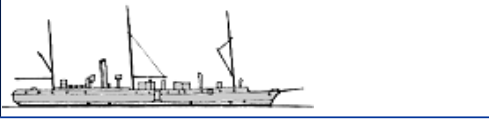
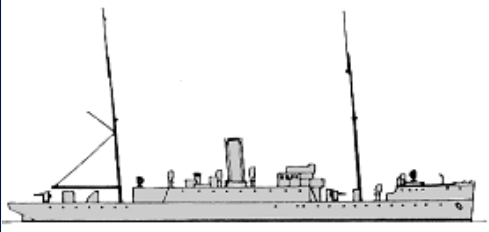
| | | | | | | |
|----|---------|-----|---------|--|---|--|
| | | | |  | | |
| ML | Pelikan | 1 2 | Pelikan | 1891 |  | 2424t, 84.2x11.7x5.1m, 2b,2vte, 3000hp, 15kts, 195p; 4x1-88/27, 400mines |

Google™
Custom Search

© Ivan Gogin, 2014

[home](#)[World navies yesterday](#)[1900](#)

Greece 01 January 1900

BATTLESHIPS

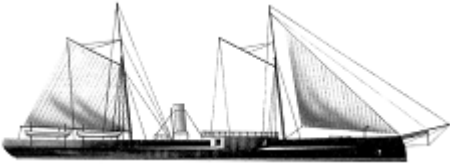
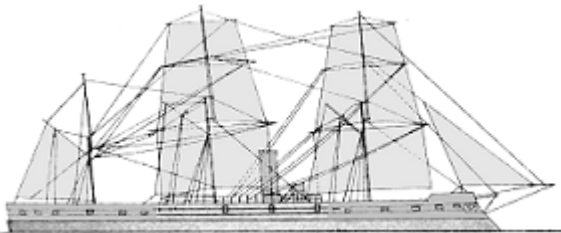
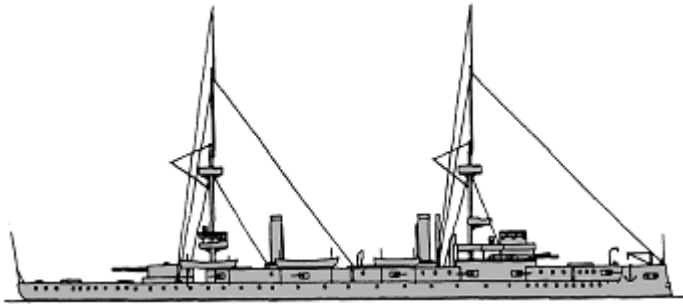
| | | | | | | | |
|----|-------------------|---|---------|-------------------|------|--|---|
| BC | Vasilefs Georgios | 1 | 1 | Vasilefs Georgios | 1868 |  | 1774t, 61.0ppx10.1x4.9m, 4b,2vte, 3000hp, 14kts, 152p; iron- 178belt, 152battery, 25deck; 2x1-209/20, 1x1-149/27, 9x1-37/37 |
| | Vasilissa Olga | 1 | 2 | Vasilissa Olga | 1870 |  | 2030t, 76.0ppx11.9x5.8m, 4b,1vte, 4000hp, 16.5kts, 258p; iron- 152belt, 121battery, 25deck; 4x1-173/22, 2x1-173/17, 4x1- 75/35, 4x5-37/17 |
| | Idra | 3 | 3 | Idra | 1892 |  | 4885t, 102.0ppx15.8x5.5m, 4b,2vte, 6700hp, 17kts, 440p; steel, compound- 305belt, 57deck, 350casemate, 305barbette; 2x1- 274/34, 1x1-274/28, 1x1-100/48, 8x1- 65/50, 4x1-47/40, 10x5-37/17, 1-381TT, 2-356TT |
| 4 | | | Spetsai | 1892 | | | |
| 5 | | | Psara | 1891 | | | |

CRUISERS

| | | | | | | | |
|-----|--------------------|---|---|--------------------|------|------------|---|
| CLL | Navarchos Miaoulis | 1 | 1 | Navarchos Miaoulis | 1879 | No picture | 1820t, 75.0ppx11.0x4.4m, 1hc, 2400hp, 13.5kts, 180p; 3x1-173/22, 1x1-173/17, 6x1-37/20, 3-356TT |
|-----|--------------------|---|---|--------------------|------|------------|---|

TORPEDO SHIPS

| | | | | | | | |
|----|----------|---|-----------|---|------|------------|---|
| TB | Ionia | 2 | 1, 2 | Sfinx, Ionia | 1881 | No picture | 35t, 27.1x3.4x1.0m, 1b,1vc, 500hp, 17.5kts, 9p; 2-356TC |
| | Fereniki | 5 | 3-7 | Fereniki, Terpsihori, Persefoni, Terpsithea, Kalithea | 1881 | No picture | 42t, 30.5x3.7x1.3m, 1b,1vc, 320hp, 16kts, 12p; 2-356TT, 1spar torpedo |
| | Samos | 6 | 8- 13 | Samos, Khios, Mitilini, Kos, Rodos, Kipros | 1881 | No picture | 40t, 30.5x3.7x1.3m, 1b,1vc, 450hp, 19.5kts, 12p; 2x5-37/17, 2-356TT |
| | No11 | 6 | 14- 19 | No11-16 | 1885 | | 85t, 37.5x4.7x1.7m, 1b,1vc, 1000hp, 18kts, 20p; 1x5-37/17, |



(2+1x1)-356TT

SUBMARINES

| | | | | | | | |
|----|-----------------|---|---|-----------------|------|---------------|--|
| SS | Nordenfelt I | 1 | 1 | Nordenfelt I | 1885 | No picture | 60/ t, 19.5x2.7x3.4m, 1b,1vc, 100hp, 9/4kts, 3p; 1x1-25/42, 1-356TT |
|----|-----------------|---|---|-----------------|------|---------------|--|

OTHER FIGHTING SHIPS

| | | | | | | | |
|----|-----------|---|-----------|--------------------------------|---------------|------------|---|
| PG | Afroessa | 2 | 1 | Afroessa | 1857 | No picture | 380t, 38.0x7.0x2.7m, 160hp, 9kts; 1x1-87/22 |
| | | | 2 | Plixavra | 1857 | | |
| | Salaminia | 2 | 3 | Paralos | 1859 | No picture | 380t, 37.5x7.3x3.0m, 200hp, 8kts; 1x1-87/22 |
| | | | 4 | Salaminia | 1859 | | |
| | Sfaktiria | 4 | 5- 8 | Alfa, Beta, Gamma, Delta | 1880- 1881 | No picture | 52t, 22.0x4.5x1.5m; 1x1-149/24, 1spar torpedo |
| | Hydra | 2 | 9 | Amvrakia | 1881 | No picture | 470t, 39.0ppx7.9x2.2m, 2vc, 690hp, 12kts, 64p; 1x1-263/27, 1x1-149/27, 2x1-37/20, 1- 356TT |
| | | | 10 | Aktion | 1881 | | |
| | Achelaos | 4 | 11 | Achelaos | 1884 | | 400-420t, 41.0-42.0x7.4-7.6x3.5-4.0m, vc, 400hp, 9.8(11,12)-10.5(13,14)kts, 73p; 2x1- 95/26, 2x1-37/20(11,12), 3x1-37/20(13,14) |
| | | | 12 | Alpheos | 1884 | | |
| | | | 13 | Eurotas | 1884 | | |
| | | | 14 | Peneos | 1885 | | |
| | Aidon | 1 | 15 | Aidon | 1884 | No picture | 86t |
| | Kichli | 2 | 16, 17 | Kichli, Kissa | 1884 | No picture | 86t, 24.2x4.9x2.1m, 1vc, 162hp, 10kts |

MINE WARFARE SHIPS

| | | | | | | | |
|-----|-----------|---|---|------------|------|---------------|--|
| ML | Aigialeia | 3 | 1 | Aigialeia | 1881 | No picture | 300t, 23.0x4.0x2.6m, 1vc, 300hp, 9kts; 20mines |
| | | | 2 | Monemvasia | 1881 | | |
| | | | 3 | Nafplia | 1881 | | |
| AML | - | 1 | 1 | Kanaris | 1878 | | 870t, 91.2x9.2m, 500hp, 14kts; 2x1-120/22, 2x5-37/17, 4- 356TT, mines |

© Ivan Gogin, 2014



[home](#)[World navies yesterday](#)[1900](#)

Haiti 01 January 1900

CRUISERS

| | | | | | | | |
|----|------------|---|---|------------|------|------------|---|
| CL | Dessalines | 1 | 1 | Dessalines | 1883 | No picture | 1200t, 56.4x9.8x4.5m, 760hp, 16kts; 2x1-107/29, 1x1-100/26, 2x1-87/22 |
|----|------------|---|---|------------|------|------------|---|

OTHER FIGHTING SHIPS

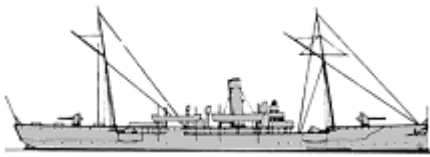
| | | | | | | | |
|-----------------|----------------------|---|-----------------|----------------------|--|---|--|
| PG | 22 Décembre 1804 | 1 | 1 | 22 Décembre 1804 | 1860 | No picture | 900t, 63.4x9.1x4.9m, 360hp, 9kts; 4x1-121/22 |
| | 1804 | 1 | 2 | 1804 | 1875 | No picture | 600t, 44.2x8.8x3.1m, 100hp, 12kts; 6x1-121/22 |
| | Saint Michael | 1 | 3 | Saint Michael | 1875 | No picture | 850t, 49.4x10.7x3.4m, 120hp, 12kts; 1x1-279/12, 8x1-102/22 |
| | Toussaint Louverture | 1 | 4 | Toussaint Louverture | 1886 |  | 500t, 50.0ppx7.5x3.3m, 1vc, 790hp, 13kts; 1x1-165/28, 2x1-120/27 |
| | Capois La Mort | 2 | 5 | Capois La Mort | 1893 |  | 256t, 45.0x6.2x2.1m, 680hp, 14kts; 1x1-100/50, 4x1-37/20 |
| | | | 6 | Alexander Pétion | 1893 | | |
| Crête-à-Pierrot | 1 | 7 | Crête-à-Pierrot | 1895 |  | 950t, 1vte, 16kts; 1x1-165/45, 1x1-120/45, 4x1-100/45 | |

© Ivan Gogin, 2015

[home](#)

[World navies yesterday](#)

[1900](#)

Honduras 01 January 1900

COASTAL FORCES

| | | | | | | | |
|----|------------|---|---|------------|------|------------|-----------|
| YP | 22 Februar | 1 | 1 | 22 Februar | 1897 | No picture | 13t, 22hp |
|----|------------|---|---|------------|------|------------|-----------|

© Ivan Gogin, 2015

[home](#)[World navies yesterday](#)[1900](#)

India 01 January 1900

BATTLESHIPS

| | | | | | | | |
|-----|-----------|---|---|-----------|------|--|---|
| MON | Abyssinia | 1 | 1 | Abyssinia | 1870 |  | 2901t, 68.6ppx12.8x4.5m, 2drcr, 1200hp, 9.6kts, 100p; iron: 178belt, 38deck, 254turrets; 2x2-203/30 |
|-----|-----------|---|---|-----------|------|--|---|

TORPEDO SHIPS

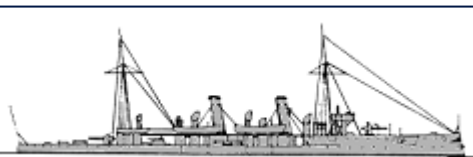
| | | | | | | | |
|-----|--------------|---|---|---------|------|--|--|
| PGT | Sharpshooter | 2 | 1 | Assaye | 1892 |  | 735t, 70.1ppx8.2x3.2m, 4b,2vte, 3600hp, 19kts, 91p; 2x1-120/40, 4x1-47/40, (1+2x1)-356TT |
| | | | 2 | Plassey | 1892 | | |

Custom Search

© Ivan Gogin, 2014

[home](#)[World navies yesterday](#)

1900



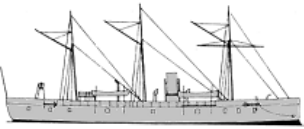
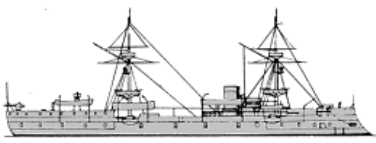
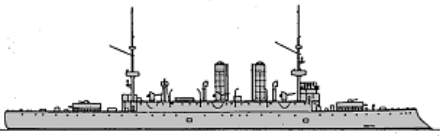
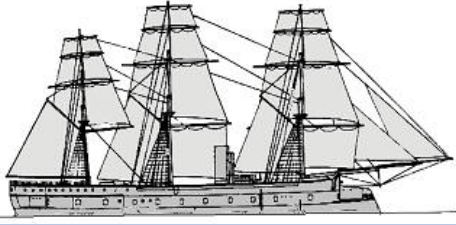
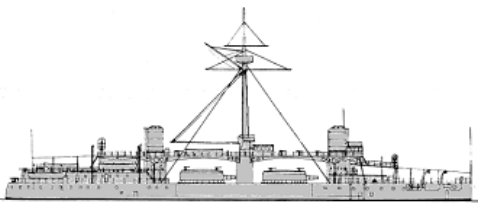
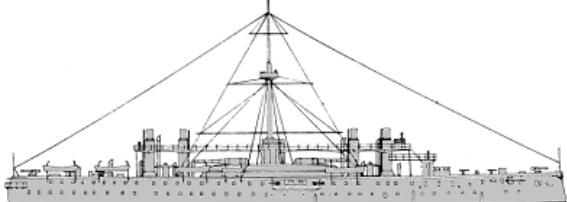
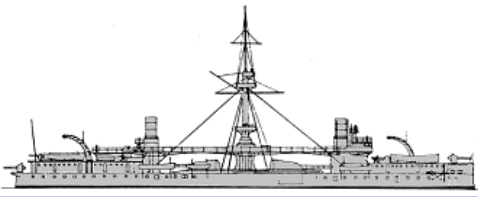
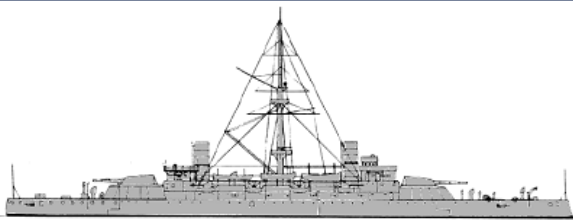

Italy 01 January 1900



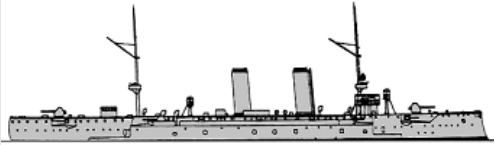
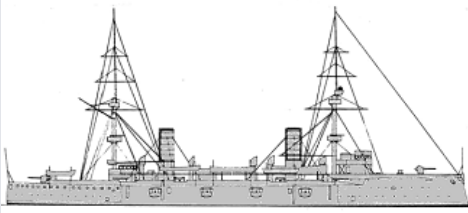
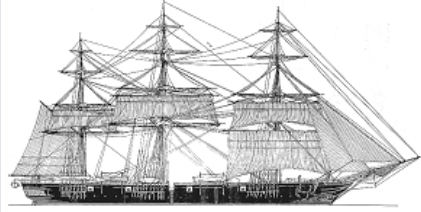
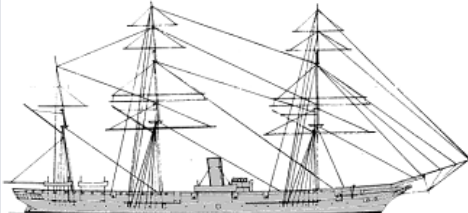
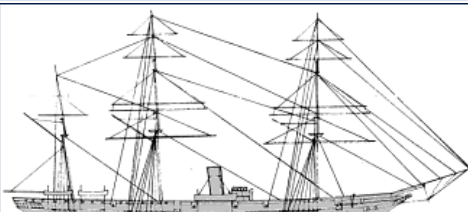
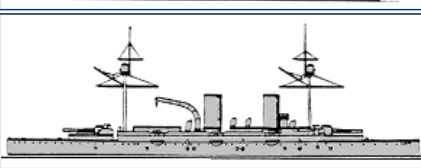
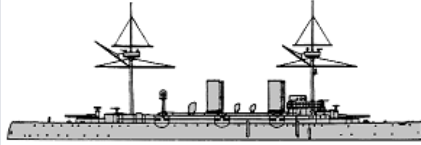

BATTLESHIPS

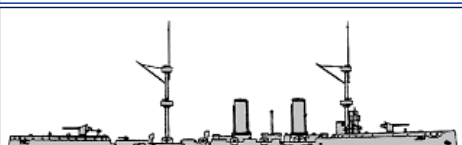
| | | | | | | |
|--------------------|---|----|--------------------|------|--|--|
| Formidabile | 2 | 1 | Terribile | 1861 |  | 2682t, 2807(1)-2618(2)t, 65.8x14.4x5.5m, 6b,1hse, 1100(1)-1080(2)hp, 10kts, 371p; iron, 110belt, 100battery; 2x1-152/33(1), 2x1-149/26(1), 2x1-120/20(1), 6x1-120/32(2), 2-350TT(1) |
| | | 2 | Formidabile | 1862 | | |
| Regina Maria Pia | 4 | 3 | Regina Maria Pia | 1864 |  | 4527(3-5)-4619(6)t, 81.2(3,4)-81.8(5,6)x15.2x6.4m, 6b,1hse(3,4)-8b,1hse(5,6), 2125-2924hp, 12.1-13.7kts, 484p; iron, 120(3,4)-110(5,6)belt, 110battery; 8x1-152/33, 5x1-120/24(3,4), 6x1-120/24(5,6), 4x1-57/40, 8x5-37/20(3-5), 2x5-37/20(6), 3-350TT(3,4,6) |
| | | 4 | San Martino | 1864 | | |
| | | 5 | Castelfidardo | 1864 | | |
| | | 6 | Ancona | 1866 | | |
| Affondatore | 1 | 7 | Affondatore | 1866 |  | 4307t, 93.8x12.2x6.4m, 8b,1hse, 3240hp, 12kts, 356p; iron, 127belt, 51deck, 127turrets, 127CT; 2x1-254/30, 6x1-120/24, 1x1-75/21, 8x1-57/40, 4x5-37/20, 2-450TT |
| Principe Amedeo | 1 | 8 | Palestro | 1875 |  | 6318t, 78.8ppx17.3x8.0m, 6b,1hse, 6117hp, 12.9kts, 548p; iron, 220belt, 140battery, 60CT; 1x1-279/13, 6x1-254/15 |
| Duilio | 2 | 9 | Duilio | 1880 |  | 12071(9)-11264(10)t, 109.2x19.7x8.3m, 8b,2vc, 7711(9)-8045(10)hp, 15(9)-15.6(10)kts, 420(9)-495(10)p; steel, 550belt, 50deck, 430(9)-225(10)turrets; 2x2-450/20(9), 2x2-254/40(10), 7x1-152/40(10), 3x1-120/40(9), 5x1-120/40(10), 16x1-57/43(10), 8x5-37/20(10), 4x1-11.4/94(10), 3-350TT(9), 4-450TT(10), 1TB(9) |
| | | 10 | Dandolo | 1882 | | |
| Italia | 2 | 11 | Italia | 1885 |  | 15047(11)-15649(12)t, 124.7x22.5(11)-22.3(12)x8.8(11)-9.4(12)m, 24b,4vc, 11986(11)-15797(12)hp, 17.8(11)-18.4(12)kts, 669p; 2x2-432/26-27(11), 2x2-432/27(12), 8x1-152/32(12), 7x1-149/26(11), 4x1-120/32, 2x1-76/40, 6x1-57/40(11), 12x1-57/40(12), 10x5-37/20(11), 12x5-37/20(12), 2x1-11.4/94(11), 6-350TT(11), 4-350TT(12); 10000men |
| | | 12 | Lepanto | 1887 | | |
| Ruggiero di Lauria | 3 | 13 | Ruggiero di Lauria | 1888 |  | 10997(13)-11145(14)-11027(15)t, 105.9x19.8x8.3m, 8b,2vc, 10000-10500hp, 16-17kts, 507p; steel, 450belt, 75deck, 360barbettes, 250CT; 2x2-432/27, 2x1-153/32, 4x1-120/32, 2-350TT |
| | | 14 | Francesco Morosini | 1889 | | |
| | | 15 | Andrea Doria | 1891 | | |
| Re Umberto | 3 | 16 | Re Umberto | 1893 |  | 15454(16)-14842(17)-15426(18)t, 127.6(16)-130.7(17,18)x23.4x9.3(16)-8.8(17,18)m, 18b,2vc(16,17)-18b,2vte(18), 17000(16)-19131(17)-22800(18)hp, 18.2(16)-20(17,18)kts, 733-794p; steel, 100belt, 75deck, 100turrets, 300CT; 2x2-343/30, 8x1-152/40, 16x1-57/43(16), 20x1-57/43(17,18), 10x1-37/25, 5-450TT |
| | | 17 | Sicilia | 1895 | | |
| | | 18 | Sardegna | 1895 | | |



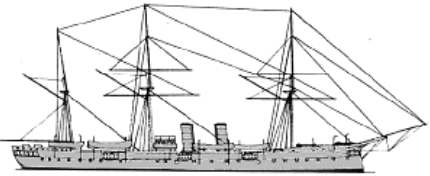
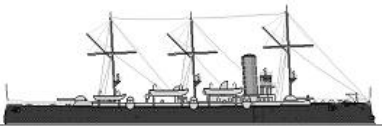

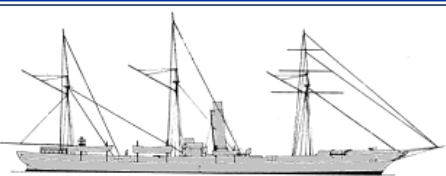

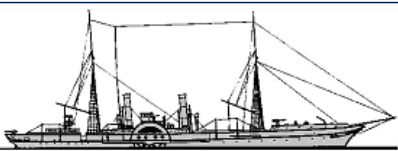
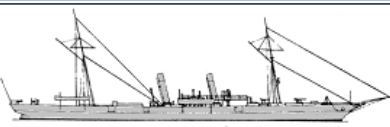
CRUISERS





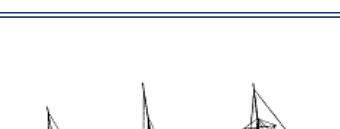







| | | | | | | |
|-------------------|---|---|-------------------|------|------------|--|
| Vittorio Emanuele | 1 | 1 | Vittorio Emanuele | 1856 | No picture | 3300t, 61.9x15.3x6.3m, 3b,1hc, 1488hp, 9kts, 539p; 10x1-164/17, 2x1-120/40 |
|-------------------|---|---|-------------------|------|------------|--|

| | | | | | | | | |
|--------------------|------------------|----|--------------------|------------------|-------------------|---|---|---|
| CA | Maria Adelaide | 1 | 2 | Maria Adelaide | 1860 | No picture | 3543t, 74.4ppx15.1x6.5m, 4b,1hc, 2255hp, 12kts, 578p; 1x1-229/14, 8x1-203/13, 4x1-164/17 | |
| | Marco Polo | 1 | 3 | Marco Polo | 1894 |  | 4820t, 106.1x14.7x5.9m, 4b,2vte, 10663t, 17.8kts, 402p; 100belt, 25deck, 50shields, 50CT; 6x1-152/40, 10x1-120/40, 2x1-75/21, 9x1-57/40, 2x1-37/25, 2x1-11.4/94, 5-450TT | |
| | Vettor Pisani | 2 | 4 | Carlo Alberto | 1898 |  | 7057(4)-7128(5)t, 105.7x18.0x7.2m, 8b,2vte, 13219(4)-13259(5)hp, 19.1(4)-18.6(5)kts, 486p; Harvey, 150belt, 37deck, 150casemates, 150CT; 12x1-152/40, 6x1-120/40(4), 4x1-120/40(5), 2x1-75/21, 14x1-57/40, 6x1-37/25(4), 8x1-37/25(5), 2x1-11.4/94, 4-450TT | |
| | | 5 | Vettor Pisani | 1899 | | | | |
| CL | Caracciolo | 1 | 1 | Caracciolo | 1870 |  | 1661t, 64.3ppx10.9x5.0m, sails, 247p; 2x1-75/21, 4x1-57/40 | |
| | Flavio Gioia | 1 | 2 | Flavio Gioia | 1883 |  | 3064t, 84.5x12.8x5.2m, 8b,1hr, 4156hp, 14kts, 268p; steel, deck; 4x1-120/40, 2-350TT | |
| | Amerigo Vespucci | 1 | 3 | Amerigo Vespucci | 1884 |  | 2751t, 84.5x12.8x5.5m, 8b,1hr, 3000hp, 13kts, 268p; 4x1-120/40, 4x1-57/40, 2x1-37/20, 2-350TT | |
| | Giovanni Bausan | 1 | 4 | Giovanni Bausan | 1885 |  | 3277t, 89.3x12.9x6.0m, 4b,2vde, 6470hp, 17.4kts, 295p; compound, 38deck, 13CT; 2x1-254/30, 6x1-152/40, 4x1-57/40, (6x5+3x1)-37/20, 2x1-11.4/94, 2-350TT | |
| | Etna | | | 5 | Etna | 1887 |  | 3737-3888t, 91.4x13.2x5.8m, 4b,2vde, 6252-7480hp, 16.6-18kts, 308p; compound, 38deck, 13CT; 2x1-254/30, 6x1-152/32(5-7), 6x1-152/40(8), 5x1-57/40(5-7), 6x1-57/40(8), (1x5+5x1)-37/20(5-7), 8x1-37/20(8), 2x1-11.4/94, 2-350TT(4-7), 3-350TT(8) |
| | | | | 6 | Vesuvio | 1888 | | |
| | | | | 7 | Stromboli | 1888 | | |
| | | | | 8 | Ettore Fieramosca | 1889 | | |
| | Dogali | 1 | 9 | Dogali | 1887 |  | 2050t, 76.2x11.3x4.4m, 4b,2vte, 5012hp, 17.7kts, 224p; compound, 51deck, 114shields, 51CT; 6x1-152/32, 9x1-57/40, 6x5-11.4/94, 4-350TT | |
| | Piemonte | 1 | 10 | Piemonte | 1889 |  | 2597t, 97.8x11.6x4.9m, 4b,2vte, 7100hp, 20.4kts, 298p; compound, 76deck, 114shields, 76CT; 2x1-152/40, 10x1-120/40, 10x1-57/40, 6x1-37/20, 4x1-11.4/94, 2-350TT | |
| Umbria | | | 11 | Umbria | 1894 |  | 2411-2750(11-14)-2950(15)t, 84.8(11-14)-88.2(15)x12.0(11-14)-12.7(15)x4.7-5.5m, 4b,2hte, 6842-7677hp, 17-19.8kts, 213-278p; Harvey, 50deck, 50CT; 4x1-152/40, 6x1-120/40, 1x1-75/21(11), 7x1-57/40(11), 10x1-57/40(12), 8x1-57/40(13-15), 9x1-37/25(11), 2x1-37/25(13,14), 6x1-37/25(15), 2-450TT | |
| | | | 12 | Lombardia | 1893 | | | |
| | | | 13 | Etruria | 1894 | | | |
| | | | 14 | Liguria | 1894 | | | |
| | | | 15 | Elba | 1896 | | | |
| Cristoforo Colombo | 1 | 16 | Cristoforo Colombo | 1894 | | 2713t, 76.4ppx11.3x5.7m, 6b,1hc, 2321hp, 13kts, 238p; 8x1-120/40, 2x1-75/21 | | |

| | | | | | | |
|--------------------|---|----|---------------------|------|---|--|
| | | | | |  | |
| Calabria | 1 | 17 | Calabria | 1897 |  | 2660t, 81.0x12.7x5.1m, 4b,2vte, 4260hp, 16.4kts, 254p; 50deck, 50CT; 4x1-152/40, 6x1-120/40, 8x1-57/40, 8x1-37/25, 2-450TT |
| Vedetta | 1 | 1 | Vedetta | 1869 |  | 814t, 56.3x8.2x3.6m, 2b,1hse, 670hp, 11kts, 95p; 2x1-37/25, 2x5-37/20 |
| Staffetta | 1 | 2 | Staffetta | 1877 |  | 1777t, 85.6x9.4x4.0m, 2b,1hde, 1700hp, 12.5kts, 144p; 4x1-120/20, 4x1-57/43, 1-350TT |
| Rapido | 1 | 3 | Rapido | 1877 |  | 1523t, 81.1x9.3x3.8m, 4b,1vde, 1920hp, 13.5kts, 144p; 5x1-57/43, 2x1-11.4/94 |
| Agostino Barbarigo | 2 | 4 | Agostino Barbarigo | 1879 |  | 805(4)-770(5)t, 68.1x7.4x3.4m, 4b,1vte, 1704-1760hp, 15kts, 104p; 5x1-57/43, 2x1-25/41 |
| | | 5 | Marcantonio Colonna | 1880 | | |
| Messaggero | 1 | 6 | Messaggero | 1888 |  | 1137t, 72.0ppx9.1x3.2m, 4b,1hse(sw), 1797hp, 14kts, 107p; 4x1-57/43, 4x5-37/20 |
| Archimede | 2 | 7 | Galileo Galilei | 1888 |  | 886(7)-950(8)t, 77.0x8.0x3.8m, 4b,1vte, 1384-1411hp, 12kts, 73p; 4x1-120/24, 2x1-57/43, 2x5-37/20 |
| | | 8 | Archimede | 1888 | | |

TORPEDO SHIPS





| | | | | | | | |
|-----------|-----------|------------|----------|------------|---|---|---|
| PGT | Tripoli | 1 | 1 | Tripoli | 1886 |  | 952t, 73.4x7.9x3.7m, 6b,3de, 2500hp, 17.5kts, 111p; steel, 40deck; 1x1-120/32, 6x1-57/43, (3x5+2x1)-37/20, 5-350TT |
| | Folgore | 2 | 2 | Folgore | 1887 |  | 364-394t, 56.7x6.3x2.2m, 4b,2vde, 2150hp, 17kts, 70p; 1x1-76/40(3), 2x1-57/43, 2x1-57/40(3), 2x1-47/40(3), 4x1-37/25(2), 1x5-37/20(3), 3x1-350TT(2) |
| | | | 3 | Saetta | 1888 | | |
| | Goito | 4 | 4 | Monzambano | 1889 |  | 955-974t, 73.4x7.9-8.0x3.0-3.6m, 4b,3vde(4)-6b,2vde(5)-6b,3vte(6)-4b,2vde(7), 2500(5)-3180(4,6)-1962(7)hp, 18(4,6)-17(5,7)kts, 121p; steel, 40deck; 1x1-120/32(7), 6x1-57/40(4,6,7), 5x1-57/40(5), (3x5+2x1)-37/20(5), 2x1-37/20(6,7), 5-350TT(4,7), 4-350TT(6), 60mines(5) |
| | | | 5 | Goito | 1888 | | |
| | | | 6 | Montebello | 1889 | | |
| | | | 7 | Confienza | 1890 | | |
| | Partenope | 8 | 8 | Partenope | 1890 |  | 821-931t, 73.1x8.2x3.5m, 4b,2vte, 3884-4422hp, 18.1-20.8kts, 121p; 1x1-120/40(8-13,15), 2x1-120/40(14), 6x1-57/43(8-13,15), 4x1-57/43(14), 3x1-37/20(8-13,15), 2x1-37/20(14), (1+4x1)-450TT(8), (2+4x1)-450TT(9-15) |
| | | | 9 | Minerva | 1892 | | |
| | | | 10 | Euridice | 1891 | | |
| | | | 11 | Urania | 1893 | | |
| | | | 12 | Iride | 1892 | | |
| | | | 13 | Aretusa | 1892 | | |
| | | | 14 | Caprera | 1895 | | |
| | 15 | Calatafimi | 1894 | | | | |
| Nibbio | 1 | 1 | 1T | 1881 | No picture | 26t, 24.4x3.1x1.1m, 1b,1ter, 250hp, 18kts, 10p; 2-350TT | |
| Avvoltoio | 1 | 2 | 2Y | 1881 |  | 25t, 26.2x3.3x1.0m, 1b,1vte, 420hp, 21.3kts, 10p; 2-350TT | |
| Sparviero | 2 | 3, 4 | 22Y, 25Y | 1881 |  | 40t, 30.4x3.8x1.5m, 1b,1vr, 620hp, 22.5kts, 11p; 1x2-25/41, 2-350TT | |
| Aquila | 2 | 5, 6 | 23T, 24T | 1882 |  | 35t, 29.2x3.3x1.5m, 1b,1vde, 475hp, 20kts, 11p; 1x2-25/41, 2-350TT | |

| | | | | | | | |
|--------|-----------|-----|-----------|--|---|---|--|
| TB | Aldebaran | 11 | 7-17 | 26T-35T, 40T | 1882-1885 |  | 39t, 30.6x3.6x1.7m, 1b,1vde, 430-455hp, 21kts, 11p; 1x2-25/41, 2-350TT |
| | Euterpe | 1 | 18 | 18T | 1883 | No picture | 14t, 19.2x2.3x1.1m, 1b,1vte, 170hp, 17.3kts, 10p; 1x5-25/41, 2-350TT |
| | Arturo | 5 | 19-23 | 38T, 46T, 47T, 50T, 51T | 1885-1887 |  | 39t, 30.6x3.6x1.7m, 1b,1vde, 430-455hp, 21kts, 11p; 1x2-25/41, 2-350TT |
| | Vega | 6 | 24-29 | 36T, 41T, 44T, 45T, 52T, 53T | 1885-1888 |  | 39t, 30.6x3.6x1.7m, 1b,1vde, 430hp, 21kts, 11p; 1x2-25/41, 2-350TT |
| | Procione | 6 | 30-35 | 37T, 39T, 48T, 49T, 54T, 55T | 1885-1887 |  | 39t, 30.6x3.6x1.7m, 1b,1vde, 390-430hp, 21kts, 11p; 1x2-25/41, 2-350TT |
| | Clio | 1 | 36 | 11T | 1885 | No picture | 31t, 23.4x3.0x1.5m, 1b,1ter, 250hp, 18kts, 10p; 2-350TT |
| | Acquario | 2 | 37, 38 | 42T, 43T | 1885 |  | 39t, 30.6x3.6x1.7m, 1b,1vde, 387-430hp, 21kts, 11p; 1x2-25/41, 2-350TT |
| | 56S | 17 | 39-55 | 81S-85S, 99S-104S, 106S-111S | 1886-1887 |  | 78t, 39.8x4.8x2.0m, 1b,1vde, 902-1080hp, 21-22kts, 17p; 2x1-37/20, 2-350TT(39-50), (1+1x1)-350TT(51-55) |
| | 76Ya | 4 | 56 | 76Ya | 1887 |  | 108t, 41.2x4.3x1.5m, 2b,2vde, 1600-1640hp, 26(56,57)-22(58,59)kts, 20p; 2x5-37/20, (2+1x2)-350TT(56,57), (2+1x1)-350TT(58,59) |
| | | | 57 | 77Ya | 1887 | | |
| | | | 58 | 78Ya | 1895 | | |
| | | | 59 | 79Ya | 1896 | | |
| | 72S | 34 | 60-93 | 72S-75S, 93S-98S, 105S, 112S-123S, 128S-131S, 136S-138S, 147S-150S | 1887-1895 |  | 78t, 39.8x4.8x2.0m, 1b,1vde(60-62,64-66,68-93)-2b,1vde(63,67), 902-1080hp, 21-22kts, 17p; 2x1-37/20(60-69), 2x1-37/25(70-93), 2-350TT(60-69), (1+1x1)-350TT(70-93) |
| | 68S | 11 | 94-104 | 68S-71S, 116S-119S, 146S, 153S, 154S | 1887-1894 |  | 78t, 39.8x4.8x2.0m, 1b,1vde, 723-1946hp, 21-22kts, 17p; 2x1-37/20(94-97), 2x1-37/25(98-104), 2-350TT(94-97), (1+1x1)-350TT(98-104) |
| | 66S | 2 | 105, 106 | 66S, 67S | 1888 |  | 78t, 39.8x4.8x2.0m, 1b,1vde, 902-1080hp, 21-22kts, 17p; 2x1-37/20, 2-350TT |
| | 60S | 16 | 107-122 | 60S-65S, 112S-115S, 132S-135S, 151S, 152S | 1888-1894 |  | 78t, 39.8x4.8x2.0m, 1b,1vde(107-118,120-122)-2b,1vde(119), 683-1082hp, 21-22kts, 17p; 2x1-37/20(107-112), 2x1-37/25(113-122), 2-350TT(107-112), (1+1x1)-350TT(113-122) |
| | 56S | 18 | 123-140 | 80S, 86S-92S, 124S-127S, 139S-144S | 1888-1893 |  | 78t, 39.8x4.8x2.0m, 1b,1vde, 782-1079hp, 21-22kts, 17p; 2x1-37/20(123-130), 2x1-37/25(131-140), 2-350TT(123-130), (1+1x1)-350TT(131-140) |
| Aquila | 5 | 141 | Aquila | 1888 |  | 137t, 47.6x5.1x2.2m, 2b,2vde, 2180hp, 24kts, 24p; 2x1-37/25, (1+2x1)-350TT | |
| | | 142 | Sparviero | 1888 | | | |
| | | 143 | Falco | 1888 | | | |
| | | 144 | Nibbio | 1888 | | | |
| | | 145 | Avvoltoio | 1888 | | | |

SUBMARINES

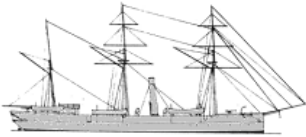
| | | | | | | | |
|----|---------|---|---|---------|------|---|---|
| SS | Delfino | 1 | 1 | Delfino | 1895 |  | 95/107t, 24.0x2.9x2.6m, 1em, 65hp, 6/5kts, 8p, 30m; 2-350TT |
|----|---------|---|---|---------|------|---|---|

OTHER FIGHTING SHIPS

| | | | | | | | |
|----|----------------|---|---|--------------------|------|---|--|
| PG | Guardiano | 1 | 1 | Sentinella | 1874 | No picture | 261t, 30.5x8.3x2.0m, 1b,2hc, 260hp, 9.1kts, 48p; 1x1-229/14 |
| | Scilla | 2 | 2 | Scilla | 1876 |  | 1059(2)-1084(3)t, 57.7wlx8.7x4.3m, 2b,1hte, 826-956hp, 10.5kts, 139p; 1x1-164/16, 3x1-120/20(2), 2x1-120/20(3), 2x1-57/43(2), 2x1-37/20(2) |
| | | | 3 | Cariddi | 1876 | | |
| | Andrea Provana | 2 | 4 | Andrea Provana | 1885 |  | 632(4)-618(5)t, 51.5x8.0x3.4m, 2b,1vte, 1087(4)-1160(5)hp, 13.6(4)-13.4(5)kts, 107p; 4x1-120/20, 4x1-25/41 |
| | | | 5 | Sebastiano Veniero | 1885 | | |
| | Curtatone | 2 | 6 | Volturno | 1889 |  | 1155(6)-1039(7)t, 54.1ppx9.9x4.5m, 3b,1vc, 1110(6)-1043(7)hp, 11.4(6)-10.7(7)kts, 144p; 4x1-120/32, 4x1-57/43, 2x1-37/20, 2x1-11.4/94, 1-350TT |
| | | | 7 | Curtatone | 1890 | | |
| | Castore | 1 | 8 | Polluce | 1891 |  | 522t, 35.1x11.3x2.5m, 2b,1vc, 364hp, 8kts, 49p; 1x1-120/40, 1x1-11.4/94 |
| | Governolo | 1 | 9 | Governolo | 1896 | | 1203t, 56.4ppx10.3x4.6m, 3b,1vc, 1100hp, 14kts, 137p; 4x1-120/32, 4x1-57/43, 2x1-37/25, 2x1-11.4/94, 1-450TT |

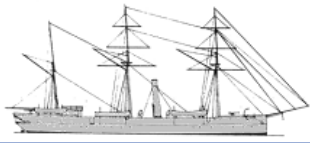

MINE WARFARE SHIPS

| | | | | | | |
|-----|---|---|---|-----------|------|-------------|
| AML | - | 1 | 1 | Betta N.3 | 1891 | 580t; mines |
|-----|---|---|---|-----------|------|-------------|



© Ivan Gogin, 2014

[home](#)[World navies yesterday](#)[1900](#)

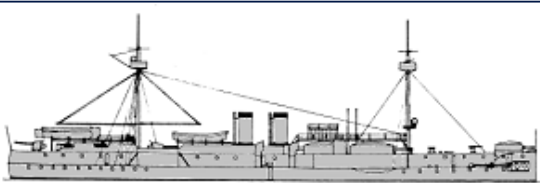
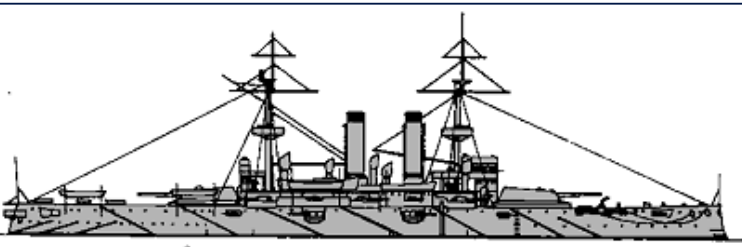
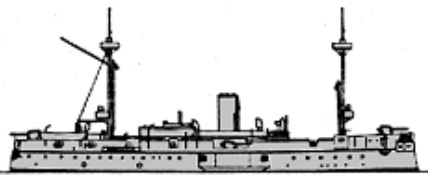
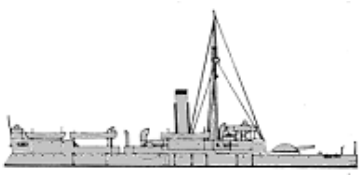

Japan 01 January 1900

BATTLESHIPS

| | | | | | | | |
|----|----------|---|---|----------|------|---|--|
| | Chin Yen | 1 | 1 | Chin Yen | 1885 |  | 7670t, 93.9x18.0x6.1m, 8b,2hc, 6300hp, 14.5kts, 329p; steel-356belt, 76deck, 305turrets, 203CT; 2x2-305/22, 4x1-152/40, 2x1-57/43, 8x1-47/40, 3-350TT, 2tb |
| BB | Fuji | 2 | 3 | Fuji | 1897 |  | 12533(2)-12320(3)t, 125.5x22.2(2)-22.4(3)x8.1(2)-8.0(3)m, 10b,2vte(2)-14b,2vte(3), 14000hp, 18kts, 741p; Harvey- 457belt, 63deck, 152turrets, 356CT; 2x2-305/40, 10x1-152/40, 20x1-47/40, 4x1-47/30, 5-450TT |
| | | | | Yashima | 1897 | | |
| BC | Fuso | 1 | 1 | Fuso | 1878 |  | 3717t, 68.9x14.6x5.5m, 8b,2hct, 3500hp, 13kts, 250p; iron- 229belt, 229battery; 4x1-235/20, 4x1-120/40, 12x1-47/40, 4x4-25/60, 2-350TT |
| | Hei Yen | 1 | 2 | Hei Yen | 1889 |  | 2640t, 70.2x12.2x4.2m, 4b,2vte, 2400hp, 10.2kts, 204p; iron- 203belt, 50deck, 125barbette, 125CT; 1x1-263/32, 2x1-149/32, 4x1-47/40, 2x10-11.4/94, 2-350TT |

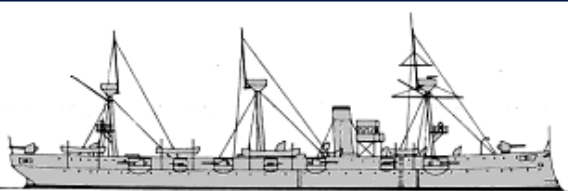
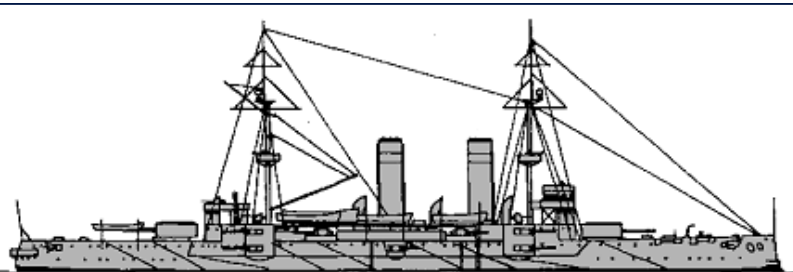
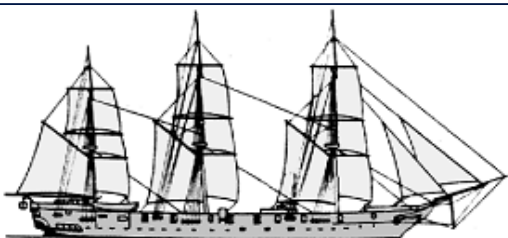
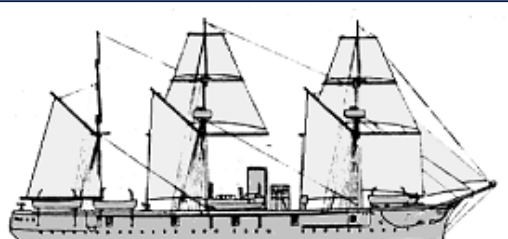

CRUISERS

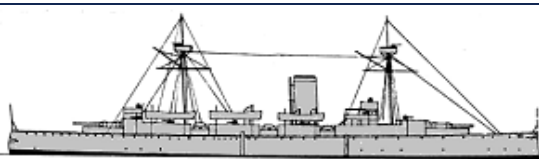
| | | | | | | | |
|--|--|--|--|--|--|--|---|
| | | | | | | | 2439t, 94.5x12.8x4.3m, 12b,2vte, 5600hp, 19kts, 350p; |
|--|--|--|--|--|--|--|---|

| | | | | | | | |
|---------|---------|---|-----------|---------|--|---|--|
| CA | Chiyoda | 1 | 1 | Chiyoda | 1891 |  | compound- 92belt, 35deck, 30CT; 10x1-120/40, 14x1-47/40, 3x10-11.4/94, 3-350TT |
| | Asama | 2 | 2 | Asama | 1899 |  | 10500t, 134.7x20.5x7.4m, 12b,2vte, 18000hp, 21.5kts, 726p; Harvey- 178belt, 76deck, 152turrets, 356CT; 2x2-203/45, 14x1-152/40, 12x1-76/40, 7x1-47/30, 5-450TT |
| | | | 3 | Tokiwa | 1899 | | |
| Tsukuba | 1 | 1 | Tsukuba | 1854 |  | 1978bm, 60.3x10.6x5.5m, 2b,1hse, 707hp, 9.5kts, 301p; 4x1-152/40 | |
| Kongo | 2 | 2 | Kongo | 1878 |  | 3718t, 70.5x12.5x5.5m, 6b,1hc(2)-2b,1hc(3), 2490hp, 14kts, 314p; compound- 114belt; 3x1-173/17, 6x1-149/22, 2x1-75/11, 2x1-47/40, 4x4-25/60, 2x5-11.4/94, 2-350TT | |
| | | 3 | Hiei | 1878 | | | |
| Kaimon | 2 | 4 | Kaimon | 1884 |  | 1429(4)-1525(5)t, 64.1(4)-64.7(5)x9.9(4)-10.8(5)x5.0(4)-5.2(5)m, 4b,1hcra, 1267hp, 12kts, 214p; 1x1-173/22, 1x1-149/22(5), 6x1-120/22(4), 4x1-120/22(5), 1x1-79/25, 4x4-25/60, 1x4-11.4/94(4) | |
| | | 5 | Tenryu | 1885 | | | |
| Naniwa | 2 | 6 | Naniwa | 1885 |  | 3708t, 97.5x14.0x6.1m, 6b,2hc, 7000hp, 18.5kts, 325p; steel- 76deck, 51barbettes, 38CT; 2x1-263/32, 6x1-152/40, 6x1-47/40, 4-350TT | |
| | | 7 | Takachiho | 1886 | | | |
| | | 8 | Katsuragi | 1887 | | | |
| | | 9 | Yamato | 1888 | | | |

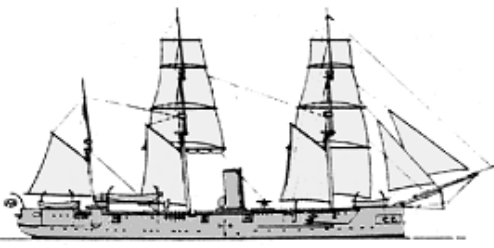
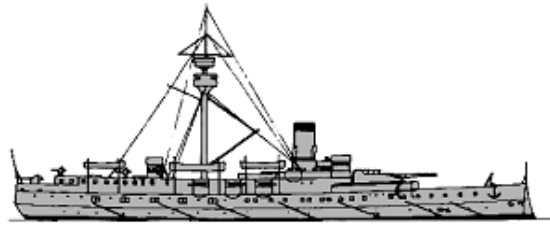
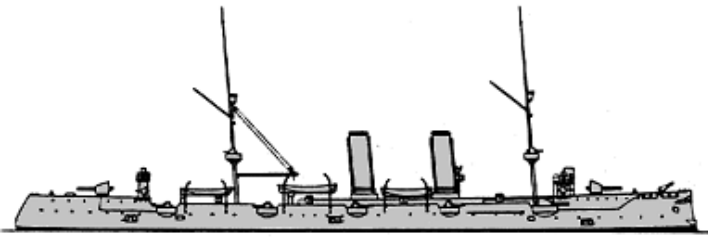
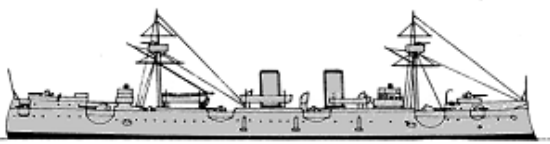
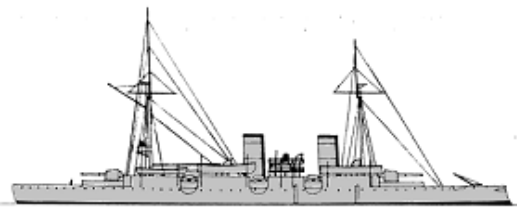
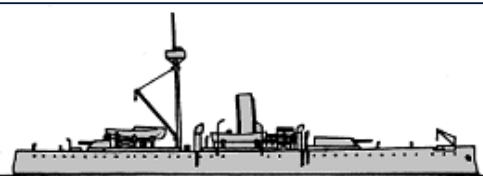
CL

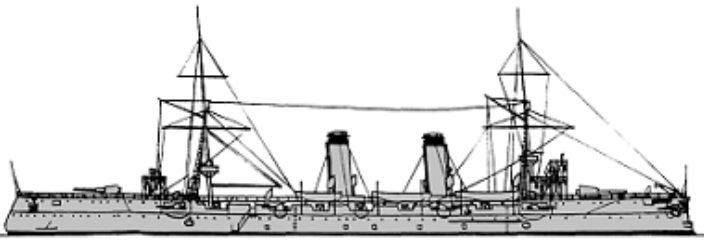
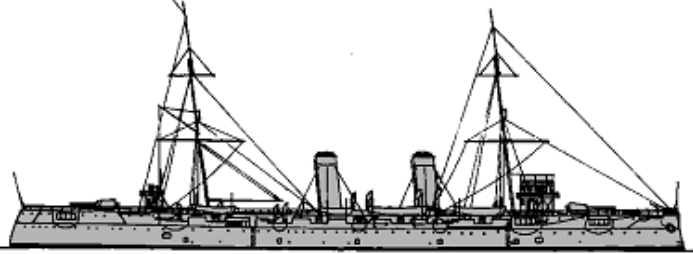
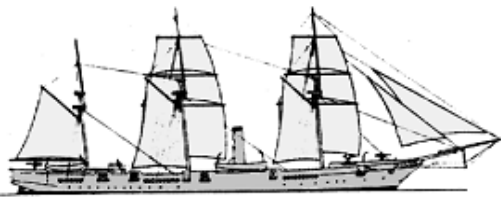

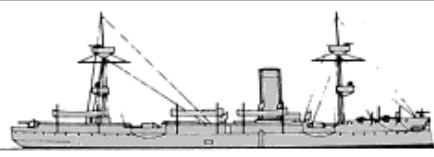
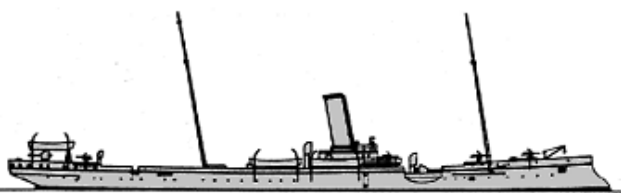



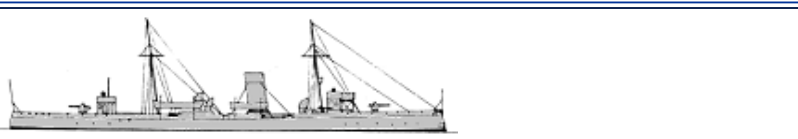
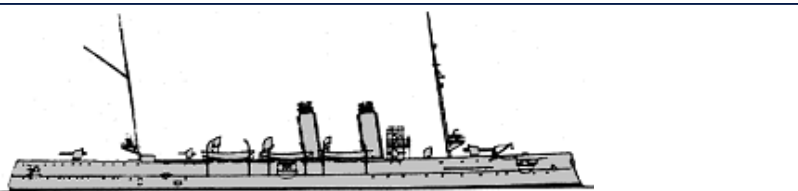

| | | | | | | |
|-------------|---|----|-------------|---|---|---|
| Katsuragi | 3 | | |  | 1502t, 62.8x10.7x4.6m, 6b,1hcra, 1622hp, 13kts, 231p; 2x1-173/22, 5x1-120/22, 1x1-79/25, 4x4-25/60, 2-380TT | |
| | | 10 | Musashi | | | 1887 |
| Itsukushima | 3 | 11 | Itsukushima | 1891 |  | 4217t, 99.8x15.4x6.0m, 6b,2hte, 5400hp, 16.5kts, 360p; Harvey- 40deck, 100turret, 125CT; 1x1-320/38, 11x1-120/40(11,13), 12x1-120/40(12), 5x1-57/40(11), 6x1-57/40(12,13), 12x1-37/20(11), 11x1-37/20(12,13), 4-350TT |
| | | 12 | Matsushima | 1892 | | |
| | | 13 | Hashidate | 1894 | | |
| Yoshino | 1 | 14 | Yoshino | 1893 |  | 4150t, 118.3x14.2x5.2m, 12b,2vte, 15750hp, 22.5kts, 385p; Harvey- 114slopes, 45deck, 114shields, 76CT; 4x1-152/40, 8x1-120/40, 22x1-47/40, 5-350TT |
| Akitsushima | 1 | 15 | Akitsushima | 1894 |  | 3150t, 92.0x13.1x5.3m, 6b,2vte, 8400hp, 19kts, 314p; Harvey- 76deck, 114shields; 4x1-152/40, 6x1-120/40, 8x1-47/40, 4-350TT |
| Idzumi | 1 | 16 | Idzumi | 1884 |  | 2920t, 82.3ppx12.8x5.6m, 12b,2hc, 6083hp, 18.2kts, 300p; compound- 25slopes, 13deck; 2x1-254/30, 6x1-120/40, 2x1-57/40, 6x1-47/40, 3-350TT |
| Sai Yen | 1 | 17 | Sai Yen | 1885 |  | 2440t, 75.0x10.4x5.2m, 2b,2vc, 2800hp, 15kts, 202p; compound- 75deck, 250barbettes, 38CT; 1x2-209/27, 1x1-149/32, 8x1-47/40, 4-350TT, 2tb |
| Suma | 2 | 18 | Suma | 1896 | | 2657(18)-2756(19)t, 95.0(18)-93.3(19)x12.2(18)-12.7(19)x4.6(18)-4.8(19)m, 8b,2vte(18)-9b,2vte(19), 8500hp, 20kts, 310p; Harvey- 51slopes, 25deck, 114shields; 2x1-152/40, 6x1-120/40, |
| | | 19 | Akashi | 1899 | | |

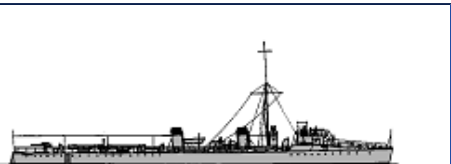
| | | | | | | |
|----------|---|----|----------|---|--|---|
| | | | |  | 10x1-47/40, 4x1-47/30, 2-380TT | |
| Takasago | 1 | 20 | Takasago | 1898 |  | 4160t, 118.2x14.8x5.2m, 8b,2vte, 15500hp, 23.5kts, 425p; Harvey- 114slopes, 63deck, 114shields, 114CT; 2x1-203/45, 10x1-120/40, 12x1-76/40, 6x1-47/30, 5-450TT |
| Chitose | 2 | 21 | Chitose | 1899 |  | 5598(21)-6066(22)t, 120.4(21)-121.5(22)x15.0(21)-14.9(22)x5.4m, 12b,2vte, 15000hp, 22.5kts, 434(21)-405(22)p; Harvey- 114slopes, 45deck, 114shields, 114CT; 2x1-203/45, 10x1-120/40, 12x1-76/40, 6x1-47/30, 5-350TT |
| | | 22 | Kasagi | 1898 | | |
| Amagi | 1 | 1 | Amagi | 1878 |  | 1030t, 65.3x10.1x4.4m, 2b,1hc, 720hp, 11.5kts, 301p; 1x1-173/22, 4x1-120/22, 1x1-120/17, 3x1-79/25, 3x4-25/60 |
| Tsukushi | 1 | 2 | Tsukushi | 1880 |  | 1542t, 64.0ppx9.7x4.4m, 4b,2hc, 2887hp, 16.5kts, 186p; steel- 10deck, 25casemates, 13CT; 2x1-254/26, 4x1-120/32, 1x1-76/40, 2x1-47/40, 2-350TT |
| Takao | 1 | 3 | Takao | 1889 |  | 1927t, 71.1x10.4x4.0m, 5b,2hc, 2330hp, 15kts, 229p; 4x1-149/32, 1x1-120/22, 1x1-79/25, 6x4-25/60, 2x2-25/60, 2-350TT |
| Yaeyama | 1 | 4 | Yaeyama | 1892 |  | 1609t, 96.9ppx10.5x4.0m, 6b,2hte, 5400hp, 20kts, 215p; steel- 13deck; 3x1-120/32, 10x1-47/40, 2-350TT |

CLL



| | | | | | | |
|---------|---|---|---------|------|--|--|
| Tatsuta | 1 | 5 | Tatsuta | 1894 |  | 850t, 73.1ppx8.4x2.9m, 4b,2vte, 5500hp, 21kts, 100p; 2x1-120/40, 4x1-47/40, 5x1-47/30, (1+2x2)-350TT |
| Miyako | 1 | 6 | Miyako | 1899 |  | 1772t, 96.0ppx10.5x4.3m, 8b,2vte, 6130hp, 20kts, 200p; 2x1-120/40, 8x1-47/40, 2-450TT |

TORPEDO SHIPS

| | | | | | | | |
|-----|----------|----|--------|-------------------------|-------------|--|--|
| DD | Murakumo | 5 | 1 | Kagero | 1899 |  | 361t, 65.7x6.0x1.7m, 3b,2vte, 5800hp, 30kts, 54p; 1x1-76/40, 5x1-57/40, 2x1-450TT |
| | | | 2 | Murakumo | 1898 | | |
| | | | 3 | Shinonome | 1899 | | |
| | | | 4 | Shiranui | 1899 | | |
| | | | 5 | Yugiri | 1899 | | |
| | Ikazuchi | 6 | 6 | Ikazuchi | 1899 |  | 410t, 68.5x6.3x1.6m, 4b,2vte, 6000hp, 31kts, 55p; 1x1-76/40, 5x1-57/40, 2x1-450TT |
| | | | 7 | Inazuma | 1899 | | |
| | | | 8 | Niji | 1899 | | |
| | | | 9 | Akebono | 1899 | | |
| | | | 10 | Oboro | 1899 | | |
| | | | 11 | Sazanami | 1899 | | |
| TB1 | Kotaka | 1 | 1 | Kotaka | 1888 |  | 203t, 50.3ppx5.8x1.7m, 2b,2vc, 1200hp, 17.8kts, 27p; steel- 25belt, 25deck; 2x4-25/60, (2+1x2)-350TT |
| | Fukuryu | 1 | 2 | Fukuryu | 1886 |  | 128t, 43.9x5.0x2.3m, 1b,1vc, 1015hp, 20kts, 27p; 2x5-37/20, 2-350TT |
| TB2 | 22-go | 1 | 1 | 25-go | 1895 |  | 85t, 39.0ppx4.8x1.1m, 1b,1vte, 990hp, 19kts, 20p; 2x1-47/30, 3x1-350TT |
| | 21-go | 2 | 2, 3 | 21-go, 24-go | 1894 - 1895 |  | 80t, 36.0ppx4.0x1.2m, 1b,1vte, 1150hp, 21kts, 21p; 1x1-47/30, 3x1-350TT |
| TB3 | 5-go | 14 | 1 - 14 | 5-go-14-go, 16-go-19-go | 1892 - 1894 |  | 54t, 35.0x3.4x0.9m, 1b,1hc, 525hp, 20kts, 16p; 1x1-47/30, (1+1x1)-350TT |
| | 15-go | 2 | 15, 16 | 15-go, 20-go | 1893 - 1894 |  | 54t, 35.0x3.5x1.0m, 1b,1vte, 657hp, 20kts, 20p; 1x1-47/30, 1x2-350TT |
| | 26-go | 2 | 17, | 26-go, 27-go | 1887 | No picture | 74t, 33.7x3.5x1.1m, 1b,1hc, 338(17)-442(18)hp, 13.8(17)-15.5(18)kts, |

| | | | | | | |
|-------|---|----|-------|------|------------|---|
| | | 18 | | | | 28p; 2x5-37/20, 2-350TT |
| 28-go | 1 | 19 | 28-go | 1885 | No picture | 16t, 19.7x2.6x1.1m, 1b,1hc, 91hp, 10.6kts, 7p; 1x1-37/20, 2-350TT |

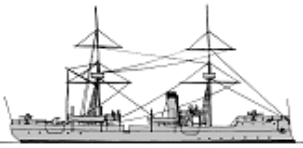
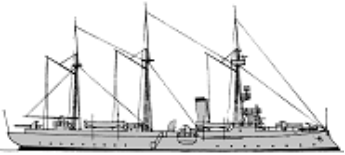
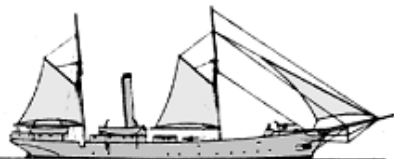
OTHER FIGHTING SHIPS

| | | | | | | | |
|---------|--------|----|---------|---------|--|--|---|
| PG | Banjo | 1 | 1 | Banjo | 1880 | No picture | 708t, 46.9x7.9x3.9m, 4b,1hc, 659hp, 10kts, 112p; 1x1-149/22, 1x1-120/22, 2x1-79/25, 3x4-25/60 |
| | Maya | 4 | 2 | Maya | 1888 |  | 622t, 46.8ppx8.2x3.1m, 2b,2hcda, 963hp, 12kts, 104p; 1x1-209/19(3,4), 4x1-120/40(2,5), 1x1-120/22(3,4), 2x1-57/43(2), 2x1-47/40(2), 4x1-47/40(5), 2x4-25/60 |
| | | | 3 | Chokai | 1888 | | |
| | | | 4 | Atago | 1889 | | |
| | | | 5 | Akagi | 1890 | | |
| | Oshima | 1 | 6 | Oshima | 1892 |  | 640t, 53.7ppx8.0x2.8m, 2b,2vte, 1200hp, 13kts, 130p; steel- 30deck; 4x1-120/40, 5x1-47/40, 1x5-11.4/94 |
| | Soko | 1 | 7 | Soko | 1869 |  | 950t, 54.9x8.6x3.3m, 1b,1hse, 425hp, 9kts, 79p; 2x1-76/40 |
| | Chinto | 4 | 8 | Chinto | 1879 |  | 490t, 38.1ppx8.8x2.9m, 2b,2hc, 450hp, 10kts, 28p; 1x1-279/23, 2x1-76/19, 2x10-11.4/94 |
| | | | 9 | Chinsei | 1879 | | |
| | | | 10 | Chinnan | 1879 | | |
| 11 | | | Chimpen | 1879 | | | |
| Chinchu | 2 | 12 | Chinchu | 1881 |  | 500t, 38.1ppx8.8x2.9m, 2b,2hc, 450hp, 10kts, 28p; 1x1-279/23, 2x1-102/25, 2x10-11.4/94 | |
| | | 13 | Chimpen | 1881 | | | |



[home](#)[World navies yesterday](#)[1900](#)

Mexico 01 January 1900

CRUISERS

| | | | | | | | |
|----|---------------|---|---|---------------|------|---|---|
| CL | Porfirio Díaz | 1 | 1 | Porfirio Díaz | 1892 |  | 1200t, 68.0x9.3x4.3m, 2b,1vte, 1300hp, 15kts, 270p; 4x1-120/40, 2x1-57/40 |
|----|---------------|---|---|---------------|------|---|---|

OTHER FIGHTING SHIPS

| | | | | | | | |
|----|---------------|---|---|---------------|------|---|--|
| PG | Independencia | 2 | 1 | Independencia | 1874 |  | 480t, 38.1x7.3x2.7m, 1hc, 425hp, 10kts, 63p; 1x1-163/16, 4x1-95/21 |
| | | | 2 | Libertad | 1874 | | |
| | Democrata | 2 | 3 | Democrata | 1875 |  | 445t, 42.7x7.6x3.4m, 600hp, 11kts, 80p; 2x1-163/16, 2x1-107/19 |
| | | | 4 | Mexico | 1875 | | |

© Ivan Gogin, 2015

[home](#)

[World navies yesterday](#)

[1900](#)

Morocco 01 January 1900

CRUISERS

| | | | | | | | |
|-----|-----------|---|---|-----------|------|---|--|
| CLL | El Bashir | 1 | 1 | El Bashir | 1892 |  | 1200t, 70.0x10.0x2.6m, 1vte, 2500hp, 18kts, 150p; 2x1-120/40, 4x1-37/25, 4-356TT |
|-----|-----------|---|---|-----------|------|---|--|

OTHER FIGHTING SHIPS

| | | | | | | | |
|----|-----------------|---|---|-----------------|------|------------|------------------------------------|
| PG | Es Sid El Turki | 1 | 1 | Es Sid El Turki | 1894 | No picture | 460brt, 1200hp, 14.5kts; 2x1-76/18 |
| | El Hassaneh | 1 | 2 | El Hassaneh | 1884 | No picture | 1164t; 1x1-173/22 |

© Ivan Gogin, 2015





[home](#)

World navies yesterday

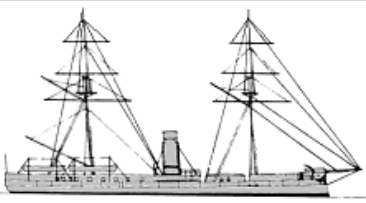

1900

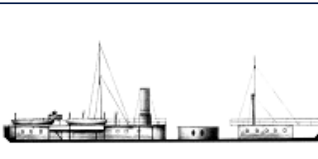
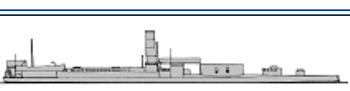
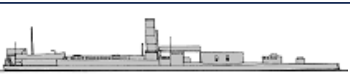
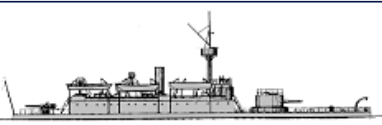

Netherlands 01 January 1900

BATTLESHIPS

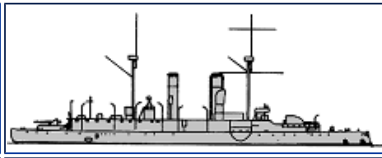
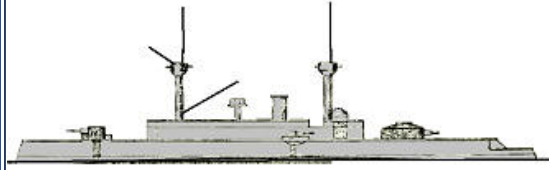
| | | | | | | | |
|------------------|-------------|----|------------------|-----------|---|--|--|
| BC | Schorpienen | 1 | Schorpienen | 1868 |  | 2140(1)-2078(2)t, 62.5x11.9x4.8(1)-5.1(2)m, 4b,2hrcr, 2225(1)-2260(2)hp, 13(1)-12.5(2)kts, 136p; iron- 152side, 25deck, 278turret, 144CT; 1x1-283/20, 5x1-37/20, 2x5-37/17 | |
| | | 2 | Stier | 1868 | | | |
| | Evertsen | 3 | 3 | Evertsen | 1896 |  | 3464t, 86.2x14.3x5.2m, 6b,2vte, 4700hp, 16kts, 263p; steel- 150belt, 55deck, 240barbette, 240CT; (1x2+1x1)-209/32, 2x1-149/32, 6x1-75/27, 8x1-37/20, 3-450TT |
| 4 | | | Piet Hein | 1896 | | | |
| 5 | | | Kortenaer | 1895 | | | |
| MON | Heiligerlee | 1 | Heiligerlee | 1868 |  | 1520t, 57.0x13.5x3.1m, 4b,2hrcr, 630hp, 9kts, 117p; iron- 140side, 25deck, 285turret, 140CT; 1x1-283/20, 2x1-37/20, 2x5-37/17 | |
| | | 2 | Krokodil | 1868 | | | |
| | Bloedhond | 2 | 3 | Bloedhond | 1870 |  | 1656(3)-1559(4)t, 55.7(3)-56.5(4)x14.2(3)-13.4(4)x3.2(3)-3.0(4)m, 4b,2hrcr, 680(3)-534(4)hp, 7.7(3)-7(4)kts, 117p; iron- 140side, 25deck, 285turret, 140CT; 1x1-283/20, 2x1-37/20, 2x5-37/17 |
| | | | 4 | Cerberus | 1870 | | |
| | Adder | 5 | 5 | Haai | 1872 |  | 1555(5,6,8,9)-1585(7)t, 58.6-59.6x13.4x3.0m, 4b,2hc, 560-740hp, 7-8kts, 117p; iron- 140side, 25deck, 285turrets, 140CT; 1x1-283/20, 2x1-37/20, 2x5-37/17 |
| | | | 6 | Hyena | 1871 | | |
| | | | 7 | Luipaard | 1878 | | |
| | | | 8 | Panter | 1871 | | |
| | | | 9 | Wesp | 1872 | | |
| | Draak | 1 | 10 | Draak | 1878 |  | 2198t, 65.1x15.0x3.6m, 4b,2hc, 807hp, 8.4kts, 131p; iron- 205side, 23deck, 305turret, 140CT; 1x2-283/20, 2x1-37/20, 2x5-37/17 |
| Matador | 1 | 11 | Matador | 1879 |  | 1968t, 63.9x14.5x3.2m, 4b,2hc, 690hp, 7.5kts, 131p; iron- 140side, 25deck, 305turret, 140CT; 1x2-283/20, 2x1-37/20, 2x5-37/17 | |
| Reinier Claeszen | 1 | 12 | Reinier Claeszen | 1894 |  | 2440t, 70.0x13.5x4.6m, 3b,2vc, 2315hp, 12.5kts, 161p; compound- 120belt, 75deck, 280turret, 280CT; 1x1-209/32, 1x1-173/32, 4x1-50/37, 2-356TT | |

CRUISERS

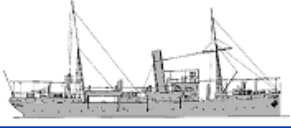
| | | | | | | | |
|----|-------------------------------------|---|---------|-------------------------------------|------|--|--|
| CL | Sumatra | 1 | 1 | Sumatra | 1891 |  | 1693t, 70.0x11.3x4.7m, 4b,2vte, 2350hp, 17kts, 181p; steel- 38deck, 100shields, 150CT; 1x1-209/32, 1x1-149/32, 2x1-120/32, 4x1-37/20, 2x5-37/17, 2-356TT |
| | Koningin Wilhelmina der Nederlanden | 1 | 2 | Koningin Wilhelmina der Nederlanden | 1894 |  | 4530t, 99.8x14.9x6.1m, 6b,2vte, 4600hp, 15.8kts, 296p; compound- 75slopes, 50deck, 280turret; 1x1-283/27, 1x1-209/32, 2x1-173/32, 4x1-75/37, 6x1-37/20, 4x5-37/17, 4-356TT |
| | | | 3 | Holland | 1898 |  | 3840t, 93.3x14.8x5.4m, 8b,2vte, 10000hp, 20kts, 371p; Harvey- |
| | | 4 | Zeeland | 1898 | | | |

| | | | | | | |
|----------|----|----|----------|------|--|---|
| | | | | | | 75/5, 2x1-37/20 |
| Batavia | 4 | 2 | Makasser | 1877 | No picture | 853t, 53.6x9.0x3.7m, 400-500hp, 8.4-9.3kts, 84-104p; 1x1-173/22(2), 1x1-149/22(3-5), 2x1-120/16(2), 3x1-120/16(3-5), 2x1-37/20(3-5) |
| | | 3 | Madura | 1880 | | |
| | | 4 | Bonaire | 1877 | | |
| | | 5 | Bali | 1878 | | |
| Suriname | 1 | 6 | Suriname | 1877 | No picture | 884t, 54.0x9.0x3.6m, 450hp, 9.5kts, 90p; 1x1-149/22, 3x1-120/16, 2x1-37/20 |
| Ceram | 2 | 7 | Ceram | 1887 | No picture | 541t, 52.8x7.8x3.1m, 800hp, 12.8kts, 83p; 3x1-120/16, 2x1-37/20 |
| | | 8 | Flores | 1887 | | |
| Lombok | 2 | 9 | Lombok | 1891 | No picture | 600t, 52.4x8.3x3.4m, 960hp, 12.3kts, 87p; 3x1-120/16, 2x1-37/20 |
| | | 10 | Sumbawa | 1891 | | |
| Borneo | 1 | 11 | Borneo | 1892 | No picture | 800t, 53.8x9.5x4.1m, 1040hp, 13.2kts, 102p; 6x1-105/32, 2x1-37/20, 2x5-37/17 |
| Nias | 4 | 12 | Nias | 1895 |  | 810-820t, 53.9x9.4x3.7m, 2vte, 1300hp, 12.9kts, 97p; 2x1-105/32, 4x1-37/20, 2x5-37/17 |
| | | 13 | Mataram | 1896 | | |
| | | 14 | Edi | 1897 | | |
| | | 15 | Serdang | 1897 | | |
| Koetei | 2 | 16 | Koetei | 1898 |  | 788t, 53.7x9.4x3.7m, 2vte, 1380hp, 13.7kts, 97p; 2x1-105/32, 4x1-37/20, 2x5-37/17 |
| | | 17 | Siboga | 1898 | | |
| Hydra | 9 | 18 | Hydra | 1873 |  | 221t, 25.9x8.0x2.2m, 2b,1vc, 124-146hp, 7.5-8kts, 34p; 1x1-209/32, 2x1-37/20, 1x5-37/20 |
| | | 19 | Ever | 1873 | | |
| | | 20 | Das | 1876 | | |
| | | 21 | Geep | 1875 | | |
| | | 22 | Gier | 1875 | | |
| | | 23 | Havik | 1874 | | |
| | | 24 | Brak | 1875 | | |
| | | 25 | Lynx | 1875 | | |
| | | 26 | Sperwer | 1875 | | |
| Wodan | 16 | 27 | Wodan | 1877 |  | 264-280t, 27.8x8.2x2.3m, 2b,1vc, 101-171hp, 7-8.3kts, 34p; 1x1-283/27(35,38-41), 1x1-283/20(27-34,36,37,42), 2x1-37/20, 1x5-37/17 |
| | | 28 | Balder | 1879 | | |
| | | 29 | Braga | 1879 | | |
| | | 30 | Freyr | 1877 | | |
| | | 31 | Heimdall | 1879 | | |
| | | 32 | Njord | 1878 | | |
| | | 33 | Thor | 1877 | | |
| | | 34 | Tyr | 1878 | | |
| | | 35 | Hefring | 1880 | | |
| | | 36 | Vali | 1879 | | |
| | | 37 | Vidar | 1879 | | |
| | | 38 | Bulgia | 1884 | | |
| | | 39 | Dufa | 1879 | | |
| | | 40 | Hadda | 1880 | | |
| | | 41 | Udur | 1879 | | |
| | | 42 | Ulfr | 1879 | | |
| Vahalis | 1 | 1 | Vahalis | 1870 | No picture | 365t, 38.4x8.5x1.6m, 240hp, 7.5kts, 34p; iron- 100side, 13deck, 25turrets; 2x1-47/40 |
| | | 2 | Isala | 1876 | | |
| | | 3 | Rhenus | 1877 | | |
| | | 4 | Mosa | 1878 | | |
| | | 5 | Merva | 1879 | | |
| Isala | 4 | 2 | Isala | 1876 | No picture | 373-388t, 48.6x7.6x1.4m, 306-400hp, 7.7-8kts, 44p; iron- 125side, 25deck, 125turrets; 2x1-120/16 |
| | | 3 | Rhenus | 1877 | | |
| | | 4 | Mosa | 1878 | | |
| | | 5 | Merva | 1879 | | |

© Ivan Gogin, 2014

[home](#)

[World navies yesterday](#)

[1900](#)

New Zealand 01 January 1900

TORPEDO SHIPS

| | | | | | | | |
|-------|----------|---|----------|--|----------------|---------------|---|
| TB2cl | Defender | 4 | 1 - 4 | Defender, Tairaroa, Waitemata, Poneke | 1883 - 1884 | No picture | 12t, 19.2ppx2.3x1.2m, 1b,1hce, 17kts, 7p; 1x2-25/40, 1-356TT |
|-------|----------|---|----------|--|----------------|---------------|---|



Custom Search

© Ivan Gogin, 2014

[home](#)[World navies yesterday](#)[1900](#)

Norway 01 January 1900

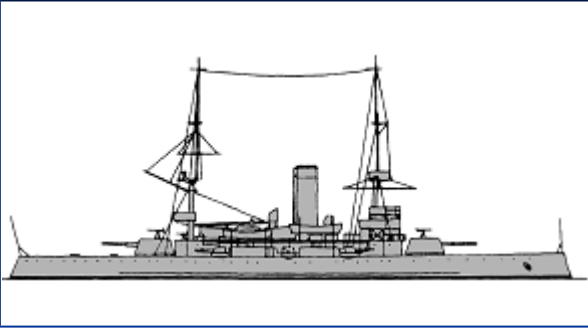
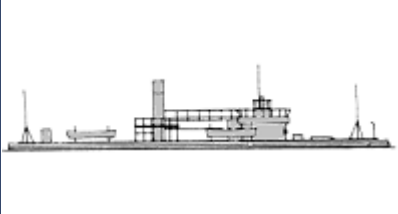
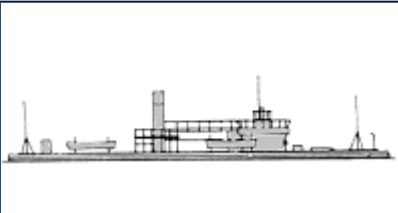
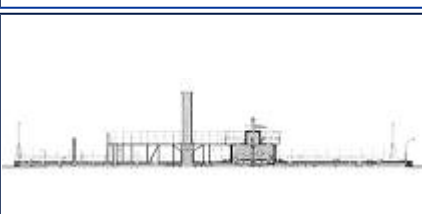





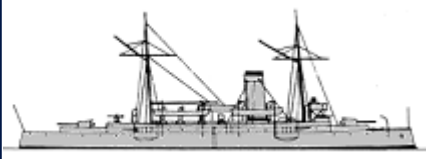
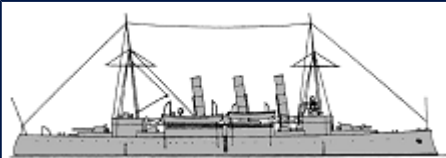





BATTLESHIPS

| | | | | | | |
|------|------------------|---|------------------|------|--|--|
| BC | Harald Haarfagre | 1 | Harald Haarfagre | 1898 |  | 3858t, 92.7x14.8x5.4m, 3b,2vte, 4000hp, 16.9kts, 245p; Harvey- 178belt, 51deck, 203turrets, 152CT; 2x1-209/44, 6x1-120/44, 6x1-76/40, 6x1-37/45, 2-450TT |
| | | 2 | Tordenskjold | 1898 | | |
| MON | Skorpionen | 1 | Skorpionen | 1867 |  | 1470t, 61.0x13.9x3.4m, 4b,1vle, 330hp, 6kts, 84p; iron- 125side, 25deck, 305turret; 1x2-120/44, 2x1-65/50, 2x1-37/40 |
| | Mjølner | 2 | Mjølner | 1868 |  | 1539t, 62.3x13.9x3.5m, 4b,1vle, 450hp, 8kts, 84p; iron- 125side, 25deck, 305turret; 1x2-120/44, 2x1-65/50, 2x1-37/40 |
| | | 3 | Thrudvang | 1869 | | |
| Thor | 1 | 4 | Thor | 1876 |  | 2035t, 62.3x14.5x3.8m, 4b,1vle, 600hp, 8kts, 94p; iron- 175side, 25deck, 365turret; 1x2-120/44, 2x1-65/50, 2x1-37/40 |

CRUISERS





| | | | | | | | |
|----|----------|---|---|----------|------|---|---|
| CL | Viking | 1 | 1 | Viking | 1891 |  | 1181t, 63.5x9.3x3.7m, 4b,2vc, 2000hp, 15kts, 125p; Harvey- 35deck, 25shields, 35CT; 2x1-149/37, 4x1-65/50, 4x1-37/20, 1-356TT |
| | Frithjof | 1 | 2 | Frithjof | 1896 |  | 1427t, 68.2x10.0x4.0m, 6b,2vte, 2800hp, 15kts, 154p; Harvey- 30deck; 2x1-120/44, 4x1-76/40, 4x1-37/45, 1-450TT |

TORPEDO SHIPS

| | | | | | | | |
|-------|-----------|---|--------|-----------------------|-----------|--|---|
| DD | Valkirjen | 1 | 1 | Valkirjen | 1896 |  | 415t, 59.4x7.4x2.6m, 2b,2vte, 3300hp, 23kts, 59p; 2x1-76/40, 4x1-37/45, 2x1-450TT |
| TB1cl | Hval | 3 | 1 | Hval | 1896 |  | 102t, 39.9x4.8x2.2m, 2b,1vte, 1100hp, 21kts, 23p; 2x1-37/45, 2x1-450TT |
| | | | 2 | Delfin | 1896 | | |
| | | | 3 | Hai | 1896 | | |
| | Storm | 3 | 4 | Storm | 1898 |  | 107t, 39.9x4.8x2.2m, 2b,1vte, 1100hp, 21kts, 23p; 2x1-37/45, 2x1-450TT |
| | | | 5 | Brand | 1898 | | |
| | | | 6 | Trods | 1898 | | |
| TB2cl | Rap | 1 | 1 | Rap | 1873 |  | 15t, 17.3x2.3x0.9m, 1b,1hda, 90hp, 15kts, 6p; 2-356TC |
| | Ulven | 1 | 2 | Ulven | 1878 |  | 16t, 17.2x2.9x1.1m, 1b,1hda, 70hp, 10kts, 6p; 2-356TC |
| | Od | 1 | 3 | Od | 1882 |  | 41t, 29.0xxm, 1b,1vc, 420hp, 18kts; 1x1-37/20, 1-356TT |
| | Springer | 1 | 4 | Springer | 1883 |  | 44t, 30.0xxm, 1b,1vc, 420hp, 18kts; 1x1-37/20, 2-356TT |
| | Rask | 2 | 5, 6 | Rask, Pii | 1885-1886 |  | 44t, 30.5xxm, 1b,1vc, 500hp, 19kts; 1x1-37/20, 2-356TT |
| | Snar | 1 | 7 | Snar | 1887 |  | 49t, 32.0xxm, 2b,1vc, 600hp, 19kts; 1x1-37/20, 2-356TT |
| | Orm | 2 | 8, 9 | Orm, Oter | 1888 |  | 54t, 33.0xxm, 2b,1vc, 600hp, 19kts; 1x1-37/20, 2-381TT |
| | Varg | 2 | 10, 11 | Varg, Raket | 1894 |  | 64t, 34.5x3.8x1.6m, 2b,1vte, 650hp, 19kts, 12p; 1x5-37/12, 2-450TT |
| | Lyn | 3 | 12-14 | Lyn, Blink, Glimt | 1896-1897 |  | 64t, 34.5x3.8x1.8m, 2b,1vte, 650hp, 19kts, 21p; 1x1-37/45, (1+1x1)-450TT |
| | Djerv | 3 | 15-17 | Djerv, Kvikk, Dristig | 1897-1898 |  | 66t, 34.5x3.8x1.7m, 2b,1vte, 650hp, 19kts, 21p; 2x1-37/45, (1+1x1)-450TT |

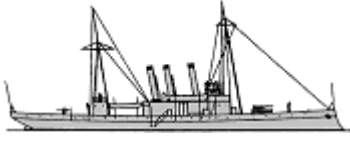
OTHER FIGHTING SHIPS

| | | | | | | | |
|--|---------|----|------|--|-----------|--|---|
| | Sarpen | 1 | 1 | Sarpen | 1861 | No picture | 220t; 2x1-65/50, 2x1-37/45 |
| | Glommen | 2 | 2 | Glommen | 1864 | No picture | 280t, 41.1xxm, 180hp, 9kts; 1x1-167/17, 1x1-155/17, 4x1-87/17 |
| | | | 3 | Lougen | 1864 | | |
| | Trold | 1 | 4 | Trold | 1872 | No picture | 97t, 65hp, 7.5kts; 1x1-155/17 |
| | Dverg | 16 | 5-20 | Dverg, Nøk, Aasgaardstrand, Kongsberg, Kristiansand, Skudesnes, Karmøe, Skien, Tønsberg, Horten, Langesund, Porsgrund, Laurvig, Arendal, Lillesand, Brevig | 1872-1883 | No picture | 55t, 70hp, 7.5kts; 1x1-155/17 |
| | Vale | 2 | 21 | Vale | 1874 |  | 229t, 27.3x7.9x2.2m, 2b,2vc, 200hp, 8kts, 38p; 1x1-267/14, 1x1- |
| | | | 22 | Uller | 1877 | | |

| | | | | | | | |
|----|----------|---|----|----------|------|--|--|
| | | | | | | | 37/20, 2x5-37/17 |
| | Sleipner | 1 | 23 | Sleipner | 1878 |  | 720t, 53.3x7.9x3.4m, 2vc, 650hp, 12kts, 90p; 1x1- 263/20, 1x1- 149/22, 1-356TT |
| PG | Brage | 2 | 24 | Brage | 1879 |  | 264t, 28.9x7.9x2.2m, 2b,2vc, 220hp, 8.5kts, 38p; 1x1- 267/14, 1x1- 37/20, 2x5-37/17, 1-356TT(25) |
| | | | 25 | Nor | 1879 | | |
| | Vidar | 1 | 26 | Vidar | 1882 |  | 262t, 28.9x7.9x2.2m, 2b,2vc, 330hp, 9.5kts, 38p; 1x1- 267/17, 1x1- 37/20, 2x5-37/17 |
| | Ellida | 1 | 27 | Ellida | 1882 | No picture | 1045t, 58.0x9.9x4.4m, 2vc, 900hp, 10.5kts, 130p; 2x1-76/40, 1x1- 75/52, 2x1-65/50, 2x1-37/45 |
| | Gor | 2 | 28 | Gor | 1885 |  | 290(28)-278(29)t, 31.3x8.5x2.2m, 2b,2vc, 420hp, 10.5kts, 44p; 1x1-263/17, 1x1- 57/40(29), 1x1- 37/20(28), 2x5- 37/17, 1-356TT |
| | | | 29 | Tyr | 1887 | | |
| | Æger | 1 | 30 | Æger | 1894 |  | 413t, 33.2x8.8x2.4m, 2b,2vte, 350hp, 9kts, 43p; 38deck; 1x1- 209/35, 1x1- 65/50, 2x1-47/40 |

FISHERY PROTECTION VESSELS



| | | | | | | | |
|-----|---------|---|---|---------|------|------------|-----------------|
| FPV | Heimdal | 1 | 1 | Heimdal | 1892 | No picture | 640t; 4x1-76/40 |
|-----|---------|---|---|---------|------|------------|-----------------|

[home](#)[World navies yesterday](#)[1900](#)

Ottoman Empire 01 January 1900

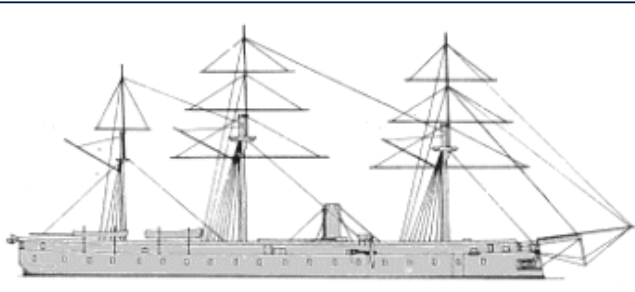
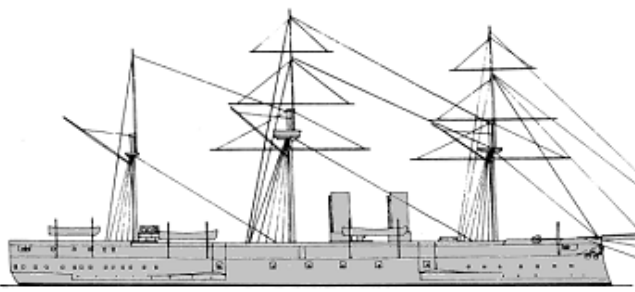
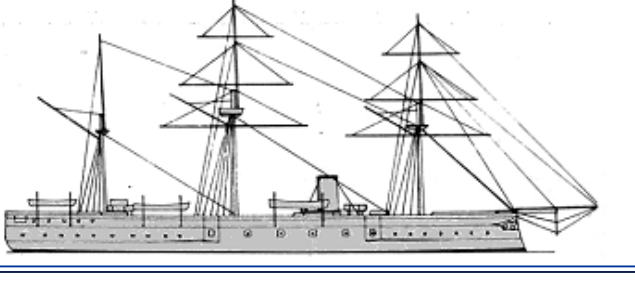
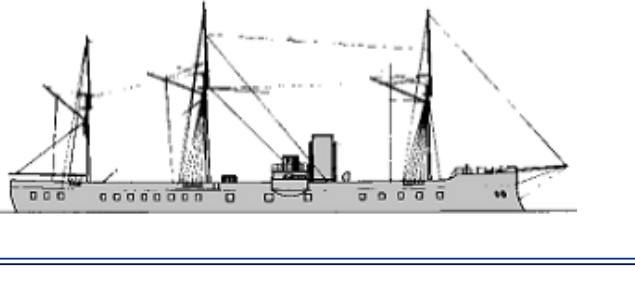
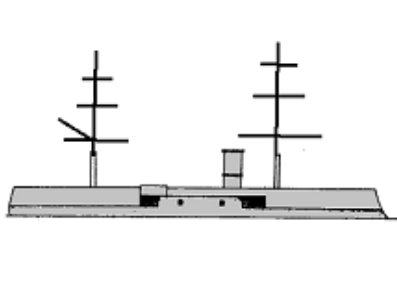
BATTLESHIPS

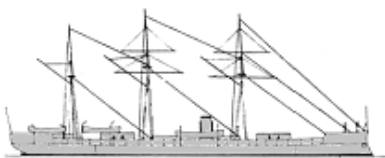
| | | | | | | |
|----|---------------|---|---------------|------|--|---|
| | Osmaniye | 1 | Osmaniye | 1865 |  | 6400t, 91.4x17.0x7.9m, 6b,vte, 3735hp, 10kts, 361p; iron- 140belt, 127battery; 2x1- 235/32, 8x1- 149/22, 5x1- 105/32, 2x1-47/40, 7x4-25/42 |
| | | 2 | Aziziye | 1865 | | |
| | | 3 | Orhaniye | 1866 | | |
| | | 4 | Mahmudiye | 1866 | | |
| BB | Mesudiye | 1 | Mesudiye | 1875 |  | 8938t, 102.4x17.9x7.9m, 8b,1hse, 7431hp, 13.7kts, 700p; iron- 305belt, 254battery, 203CT; 12x1-254/15, 3x1- 178/16, 6x1-75/37, 6x1-25/42 |
| | | 1 | Hamidiye | 1894 |  | 6594t, 89.0x17.0x7.6m, 4b,1hse, 6800hp, 13kts, 350p; iron- 229belt, 178battery, 178CT; 4x1-229/14, 10x1- 149/32 |
| | | 1 | Asar-i Tevfik | 1870 |  | 4687t, 83.0ppx16.0x6.5m, 6b,1hc, 3560hp, 13kts, 320p; iron- 203belt, 152battery; 6x1- 229/14, 2x1- 209/32, 2x1-87/22, 2x1-57/37, 2x1- 25/42 |
| | Asar-i Şevket | 2 | Asar-i Şevket | 1870 |  | 2047t, 66.4x13.0x5.0m, 4b,1hc, 1750(2)-1900(3)hp 12kts, 170p; iron- 152belt, 114battery; 1x1- 229/14, 4x1- 178/16, 2x1-87/22, 2x1-57/37, 2x5- 37/27, 1x1-25/42, 1x1-356TT(3) |
| | | 3 | Necm-i Şevket | 1870 | | |
| | | | | | | 2540t, |

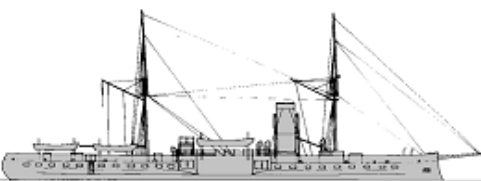
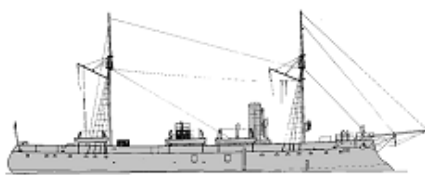
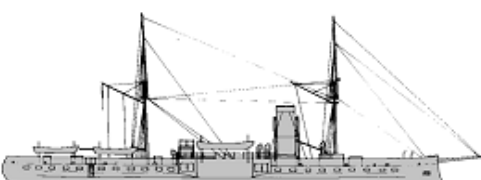

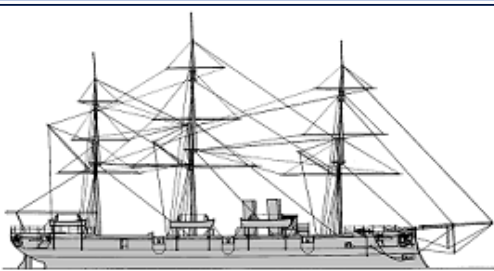

| | | | | | | | |
|-------------------|----------------|---|-------------------|----------------|--|--|--|
| BC | Hifz-ur Rahman | 1 | 4 | Hifz-ur Rahman | 1870 |  | 64.4x13.6x4.4m, 2b,2hc, 2000hp, 12kts, 122p; iron-140belt, 38deck, 140turrets; 1x2-203/15, 1x1-149/22, 1x1-120/22, 4x1-37/37, 2x4-25/42 |
| | Avnillah | 2 | 5 | Avnillah | 1870 |  | 2362t, 71.9x11.0x5.0m, 4b,1hc, 2200hp, 12kts, 145p; iron-152belt, 127casemates; 4x1-203/15, 2x1-87/22 |
| | | | 6 | Muin-i Zafer | 1870 | | |
| | Feth-i Bülend | 1 | 7 | Feth-i Bülend | 1870 |  | 2762t, 72.0ppx12.0x5.5m, 6b,1hc, 3250hp, 13kts, 169p; iron-229belt, 229casemates; 4x1-229/14, 2x1-87/22, 2x1-57/37, 2x5-37/27, 1x1-25/42 |
| | İclaliye | 1 | 8 | İclaliye | 1871 |  | 2228t, 66.0x13.0x5.3m, 2b,1hc, 1800hp, 12kts, 148p; iron-152belt, 114battery; 2x1-229/14, 2x1-178/16, 1x1-149/32, 2x1-87/22, 2x1-57/37, 2x5-37/27, 2x1-25/42 |
| Mukaddeme-i Hayir | 1 | 9 | Mukaddeme-i Hayir | 1874 |  | 2762t, 72.0ppx12.0x5.5m, 4b,1hc, 3000hp, 12kts, 169p; iron-229belt, 229casemates; 4x1-229/14, 2x1-87/22, 2x1-57/37, 2x5-37/27, 2x1-25/42 | |

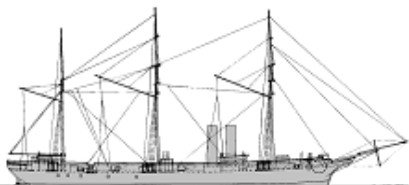
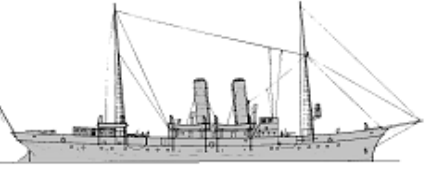
CRUISERS

| | | | | | | | |
|----|------------|---|---|------------|------|--|---|
| CL | Heybetnüma | 1 | 1 | Heybetnüma | 1895 |  | 1958t, 68.9ppx11.3x5.2m, 6b,1hte, 2786hp, 12kts, 190p; 2x1-149/22, 2x1-120/22, 4x1-47/37 |
| | Sinop | 2 | 1 | Sinop | 1860 | No picture | 787t, 53.2ppx9.3x4.5m, 2b,1hse, 640hp, 11kts, 150p; 2x1-149/22(2), 2x1-120/22(2), 3x1-50/22(1), 3x1-37/20, 2x1-25/42(2) |
| | | | 2 | Edirne | 1859 | | |
| | | | 3 | Beyrut | 1860 | | |

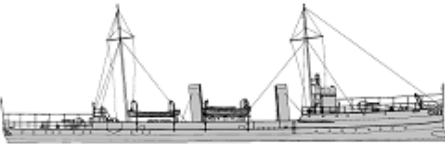

| | | | | | | | |
|----------------|---------|----|----------------|-------------|------------|---|--|
| CLL | Beyrut | 3 | 4 | İskenderiye | 1863 |  | 599t, 52.9ppx8.1x3.9m, 2b,1hse, 450hp, 10kts, 120p; 2x1-120/22, 2x1-76/19(4,5), 4x1-37/20(3), 2x1-25/42(4,5) |
| | | | 5 | Meriç | 1864 | | |
| | Mansure | 2 | 6 | Mansure | 1864 | No picture | 783bm, 55.1x9.3x4.4m, 2b,1hse, 650hp, 10kts, 130p; 2x1-149/22, 2x1-120/22, 3x1-37/20, 2x1-25/42 |
| | | | 7 | Muzaffer | 1864 | | |
| | Zuhaf | 2 | 8 | Zuhaf | 1896 |  | 643t, 57.9ppx7.3x3.5m, 2b,1vte, 640hp, 14kts, 82p; 1x1-120/22, 4x1-37/37 |
| 9 | | | Kilid Bahir | 1896 | | | |
| Lütf-ü Hümayun | 1 | 10 | Lütf-ü Hümayun | 1896 | No picture | 1313t, 64.0ppx9.1x4.0m, 2b,1hc, 2160hp, 12kts; 2x1-149/37, 2x1-120/37, 4x1-37/37, 2-450TT | |

TORPEDO SHIPS

| | | | | | | | |
|------------|----------------|----|------------|---|------------|---|---|
| PGT | Peleng-i Derya | 1 | 1 | Peleng-i Derya | 1896 |  | 900t, 75.5x8.5x2.9m, 4b,2vte, 4700hp, 18kts, 80p; 2x1-105/32, 6x1-47/37, 5x5-37/27, (1+2x1)-356TT |
| TB | Burhaneddin | 2 | 1, 2 | Burhaneddin, Tevfik | 1885 |  | 42t, 31.7x3.6x1.7m, 1b,1vc, 525hp, 17kts, 24p; 1x4-34/42, 1x4-25/42, 2-356TT, 1spar torpedo |
| | Gilyum | 5 | 3-7 | Gilyum, Saiki, Tir-i Zafer, Seyf-i Bahri, Vesile-i Nusret | 1886 |  | 85t, 37.7x4.8x2.0m, 1b,1vte, 980hp, 21kts, 18p; 2x5-37/27, 2-356TT |
| | Mecidiye | 3 | 8-10 | Mecidiye, Eser-i Terakki, Nimet | 1889-1893 |  | 42t, 31.7x3.6x1.7m, 1b,1vc, 450hp, 15kts, 24p; 1x4-34/42, 1x4-25/42, 2-356TT |
| | Nasir | 7 | 11-17 | Nasir, Fatih, Nusret, Şahab, Tarik, Pervin, Seham | 1889-1890 |  | 87t, 39.0x4.8x2.6m, 1b,1vte, 1200hp, 21kts, 27p; 2x5-37/27, 2-356TT |
| | Ejder | 1 | 18 | Ejder | 1893 | No picture | 150t, 49.2x5.7x2.2m, 2b,2vte, 2200hp, 24kts, 22p; 5x5-37/27, (1+1x1)-356TT |
| Berk Efşan | 2 | 19 | Berk Efşan | 1894 | No picture | 230t, 59.9x6.6x2.4m, 2b,2vte, 3500hp, 21kts, 50p; 6x5-37/27, 2-428TT | |
| | | 20 | Tayyar | 1894 | | | |

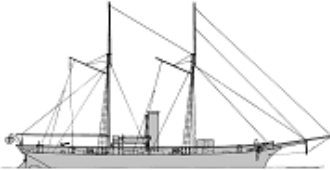
OTHER FIGHTING SHIPS

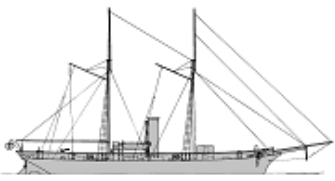
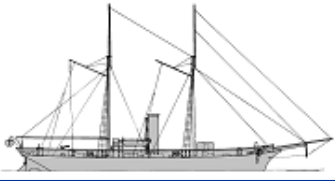
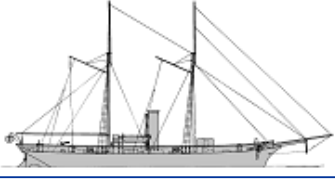
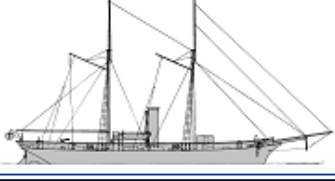
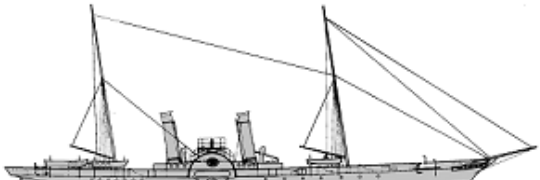
| | | | | | | |
|------|---|---|-------------|------|---|--|
| Akka | 3 | 1 | Akka | 1859 |  | 120t, 35.4x6.0x2.7m, 1b,1vte(2)-1b,1hsa(1,3), 400(2)-225(1,3)hp, 10(2)-8(1,3)kts, 45(2)-70(1,3)p; 4x1-155/14(3), 1x1-125/14(3), 4x1-75/37(2), 3x1-75/22(1), 1x1-37/37(1,2) |
| | | 2 | Şevket Nüma | 1860 | | |
| | | 3 | Necmifeşan | 1860 | | |

| | | | | | | | |
|--------|---------------|----|----------|---------------|------------|--|---|
| PG | Musul | 1 | 4 | Musul | 1866 |  | 125t, 39.9ppx6.4x2.8m, 1b,1hsa, 9kts, 35p; 2x1-57/27, 2x5-37/17 |
| | Sahir | 1 | 5 | Sahir | 1866 |  | 163t, 40.4ppx6.7x3.2m, 1b,1hsa, 8kts, 35p; 2x1-75/18, 2x5-37/17 |
| | İntibah | 2 | 6 | Müjderesan | 1866 |  | 163t, 40.4ppx6.7x3.2m, 1b,1hsa, 12kts, 35p; 4x1-75/18, 2x5-37/17 |
| | | | 7 | Ziver-i Derya | 1866 | | |
| | Saheddin | 1 | 8 | Saheddin | 1866 |  | 163t, 40.4ppx6.7x3.2m, 1b,1hsa, 12kts, 35p; 4x1-75/18, 2x5-37/17 |
| | Aynalikavak | 1 | 9 | Aynalikavak | 1869 | No picture | 195t, 35.9ppx5.3x1.8m, 1b,1hsa, 10kts, 35p; 1x1-57/37, 2x5-37/17 |
| | Rodos | 1 | 10 | İstanköy | 1874 | No picture | 203bm, 35.7ppx5.3x1.8m, 1b,1hsa, 12kts, 35p; 2x1-57/37, 2x5-37/17 |
| | Firat | 2 | 11 | Firat | 1885 | No picture | 197t, 37.0ppx6.5x2.4m, 1b,1hc, 280hp, 10kts, 55p; 2x1-88/27, 1x1-47/37, 1x1-37/20 |
| | | | 12 | Şat | 1885 | | |
| | Sulhiye | 1 | 13 | Sulhiye | 1868 | No picture | 161t, 36.5x5.7x2.3m, 1b,1hda(sw); 2x1-small guns |
| Sarıye | 3 | 14 | Sarıye | 1869 | No picture | 103t, 30.9x7.5x2.3m, 1b,1hda(sw) | |
| | | 15 | Nedim | 1869 | | | |
| | | 16 | Bozcaada | 1869 | | | |
| APG | - | 1 | 1 | Gemlik | 1848 | | 219t |
| DV | İzzeddin | 1 | 1 | İzzeddin | 1865 |  | 1058t, 76.2ppx9.1x3.6m, 2b,1hda(sw), 200hp, 17kts, 130p; 1x1-120/19, 3x1-75/19 |
| | Fuad | 1 | 2 | Fuad | 1865 |  | 1075t, 76.2ppx9.1x3.6m, 2b,1hda(sw), 200hp, 12kts, 130p; 2x175/37, 2x1-25/42 |
| ADV | - | 2 | 1 | Hanya | 1863 | | 816t |
| | | | 2 | Resmo | 1862 | | 765t |
| RMON | Feth-ül İslam | 2 | 1 | Feth-ül İslam | 1865 | No picture | 335t, 31.5x9.8x1.7m, 2b,2hse, 290hp, 8kts, 50p; iron- 76belt, 76battery, 13CT; 2x1-178/16(1), 2x1-76/18 |
| | | | 2 | Memduhiye | 1865 | | |
| | | | | | | | 404t, 43.9ppx9.4x1.6m, |

| | | | | | | | |
|-----|--------|---|---|------------|------|------------|--|
| | Hizber | 1 | 3 | Hizber | 1876 | No picture | 1b,1hse, 400hp, 8kts, 51p; iron- 76belt, 76battery, 13CT; 2x1-120/22, 2x1- 87/22, 2x1-25/42 |
| AGS | - | 2 | 1 | İskenderun | 1895 | | 142t |
| | | | 2 | Sakiz | 1895 | | 142t |

© Ivan Gogin, 2015

[home](#)[World navies yesterday](#)[1900](#)

Persia 01 January 1900

OTHER FIGHTING SHIPS

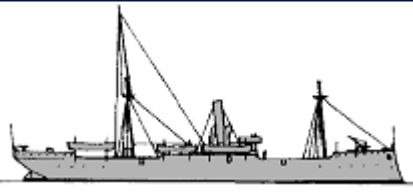
| | | | | | | | |
|-----|------------|---|---|------------|------|---|--|
| PG | Persepolis | 1 | 1 | Persepolis | 1885 |  | 1200t, 63.1x10.0x5.9m, 1vte, 450hp, 10kts; 4x1-66/26 |
| | Muzaffer | 1 | 2 | Muzaffer | 1899 | No picture | 379t, 41.1x7.9x4.0m |
| PGR | Susa | 1 | 1 | Susa | 1885 | No picture | |

© Ivan Gogin, 2015

[home](#)[World navies yesterday](#)[1900](#)

Peru 01 January 1900

CRUISERS

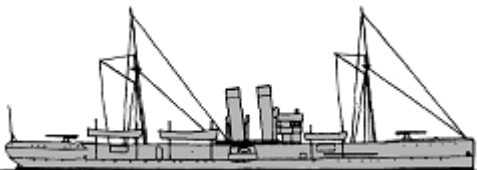
| | | | | | | | |
|-----|----------|---|---|----------|------|--|---|
| CL | Apurimac | 1 | 1 | Apurimac | 1850 | No picture | 1000t; 34guns |
| CLL | Lima | 1 | 1 | Lima | 1888 |  | 1790t, 76.2x10.7x4.6m, 4b,2hc, 1800hp, 16.2kts, 150p; 2x1-152/26, 3x1-47/40 |

OTHER FIGHTING SHIPS

| | | | | | | | |
|-----|------------|---|---|------------|------|------------|---------------------------------------|
| PG | Santa Rosa | 1 | 1 | Santa Rosa | 1883 | No picture | 2x1-152/26 |
| PGR | Iquitos | 1 | 1 | Iquitos | 1875 | No picture | 50t, 23.4x3.7x1.2m, 7.5kts; 1x1-47/40 |

© Ivan Gogin, 2015

[home](#)[World navies yesterday](#)[1900](#)

Portugal 01 January 1900

BATTLESHIPS

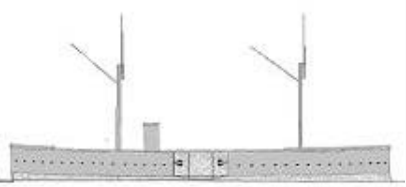
| | | | | | | | |
|----|---------------|---|---|---------------|------|---|---|
| BC | Vasco da Gama | 1 | 1 | Vasco da Gama | 1876 |  | 2384t, 61.0ppx14.2x5.8m, 2vc, 3000hp, 10.3kts, 232p; iron- 229belt, 254battery; 2x1-163/18, 1x1-149/22, 4x1-67/40 |
|----|---------------|---|---|---------------|------|---|---|

CRUISERS

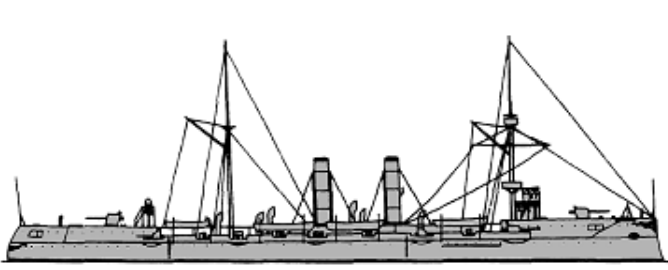
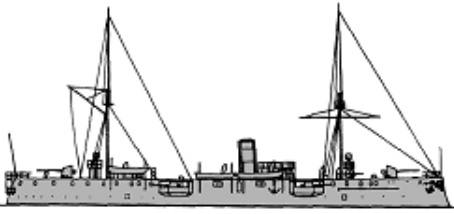
| | | | | | | | |
|-----|----------------------|---|---|----------------------|------|--|--|
| CL | Bartolomeu Dias | 1 | 1 | Bartolomeu Dias | 1858 | No picture | 2377t, 63.1ppx11.4x6.3m, 1hrct, 400hp, 10kts, 473p; 5x1-127/25 |
| | Dom Carlos I | 1 | 2 | Dom Carlos I | 1898 |  | 4253t, 117.0x14.4x5.3m, 12b,2vte, 12500hp, 22kts, 473p; 110slopes, 37deck, 102CT; 4x1-152/45, 8x1-120/44, 16x1-47/40, 2x1-37/25, 5-356TT |
| | São Gabriel | 2 | 4 | São Gabriel | 1899 |  | 1771t, 75.0x10.8x4.3m, 4b,2vte, 4000hp, 17.5kts, 242p; 20deck, 60CT; 2x1-149/45, 4x1-120/45, 8x1-47/40, 2x1-37/20, 1-356TT |
| CLL | Duque da Terceira | 1 | 1 | Duque da Terceira | 1864 | No picture | 1406t, 54.9ppx10.4x4.5m, 660hp, 10kts, 194p; 2x1-120/44, 2x1-65/40 |
| | Afonso d'Albuquerque | 1 | 2 | Afonso d'Albuquerque | 1884 | No picture | 1092t, 62.0ppx10.1x3.7m, 1360hp, 13kts, 178p; 2x1-152/26, 5x1-127/25, 2x1-47/40 |
| | Adamastor | 1 | 3 | Adamastor | 1897 | | 1757t, 74.0ppx10.7x4.7m, 4b,2vte, 4000hp, 18kts, 237p; 30deck, 65CT; 2x1-149/27, 4x1-105/37, 4x1- |

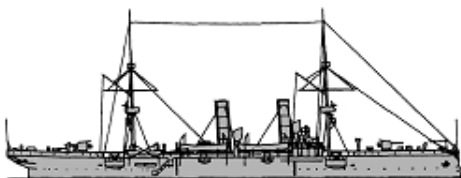
65/40, 2x1-37/25,
3-356TT

TORPEDO SHIPS

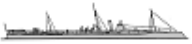
| | | | | | | | |
|----|------------|---|-----|------------|------|---|--|
| TB | Fulminante | 1 | 1 | Fulminante | 1880 | No picture | 40t, 22.9ppx4.6x0.8m, 1b,1vc, 150hp, 11.5kts; 2spar torpedoes |
| | Espadarte | 1 | 2 | N°1 | 1881 | No picture | 53t, 26.2ppx3.4x1.5m, 1b,1vc, 450hp, 19.7kts, 18p; 2-356TT |
| | N°2 | 3 | 3-5 | N°2-4 | 1886 |  | 65t, 36.5ppx3.9x1.0m, 1b,1vc, 700hp, 19kts; 2x5-37/17, 2-356TT |

SUBMARINES

| | | | | | | | |
|----|----------|---|---|----------|------|------------|--|
| SS | Plongeur | 1 | 1 | Plongeur | 1892 | No picture | /100t, 22.0x3.5xm, 2em, /6kts, 6p; 4-356TC |
|----|----------|---|---|----------|------|------------|--|

OTHER FIGHTING SHIPS

| | | | | | | | |
|----|---------------|----|-------------------------|-----------|------------|--|---|
| PG | Tejo | 1 | Tejo | 1869 | No picture | 578t, 43.6ppx7.9x3.3m, 1b,1hse, 400(1,2)-500(3)hp, 10(1,3)-9(2)kts, 109p; 1x1-163/14(2,3), 2x1-121/14, 1x1-100/27(1) | |
| | | 2 | Douro | 1873 | | | |
| | | 3 | Quanza | 1877 | | | |
| | Rio Lima | 1 | 4 | Rio Lima | 1875 | No picture | 628t, 45.4x8.6x3.2m, 500hp, 11kts, 109p; 1x1-152/26, 2x1-100/27 |
| | Rio Tâmega | 5 | Rio Tâmega | 1875 | No picture | 635t, 45.4ppx8.6x3.2m, 500hp, 11kts, 109p; 2x1-105/32, 2x1-65/40, 1x1-37/20 | |
| | | 6 | Rio Sado | 1875 | | | |
| | Tavira | 7 | Tavira | 1878 | No picture | 160t | |
| | | 8 | Faro | 1878 | | | |
| | Mandovi | 9 | Bengo | 1879 | No picture | 462t, 38.2ppx7.5x2.7m, 400hp, 10.5kts, 92p; 1x1-152/26, 2x1-87/21 | |
| | | 10 | Mandovi | 1879 | | | |
| | Rio Vouga | 1 | 11 | Rio Vouga | 1882 | No picture | 721t, 49.1ppx8.4x3.6m, 600hp, 10kts, 121p; 2x1-47/40 |
| | Vilhena | 1 | 12 | Vilhena | 1882 | No picture | 160t, 29.0x4.9x1.8m, 310hp, 12kts, 42p; 1x1-76/16 |
| | Liberal | 13 | Liberal | 1884 | No picture | 560t, 42.5ppx7.9x3.4m, 500hp, 10kts, 109p; 1x1-152/26, 2x1-100/27, 1x1-37/20 | |
| | | 14 | Zaire | 1884 | | | |
| | Massabi | 15 | Massabi | 1884 | No picture | 280t, 37.0ppx5.9x2.0m, 375hp, 11kts, 42p; 1x1-76/16 | |
| | | 16 | Cacongo | 1886 | | | |
| | Zambeze | 1 | 17 | Zambeze | 1886 | No picture | 631t, 43.6ppx7.9x3.3m, 460hp, 10kts, 113p; 3x1-100/27, 1x1-37/20 |
| | Diu | 1 | 18 | Diu | 1889 | No picture | 730t, 45.0ppx8.2x4.0m, 700hp, 11.5kts, 124p; 1x1-149/27, 2x1-105/32 |
| | Limpopo | 1 | 19 | Limpopo | 1890 | No picture | 288t, 37.8x6.4x2.0m, 1b,1vc, 520hp, 11.3kts, 42p; 1x1-65/40 |
| | D. Luiz | 1 | 20 | D. Luiz | 1895 | No picture | 789t, 45.9ppx8.3x4.2m, 500hp, 10kts, 120p; 4x1-105/32, 2x1-47/40 |
| | Thomaz Andrea | 21 | Thomaz Andrea | 1896 | No picture | 300t, 41.0ppx8.0x2.0m, 500hp, 12kts; 2x1-47/40 | |
| | | 22 | Al. Baptista de Andrade | 1897 | | | |
| | Chaimite | 1 | 23 | Chaimite | 1898 | | 341t, 41.0ppx8.0x2.0m, 2vte, 480hp, 11kts, 26p; 2x1-47/40 |

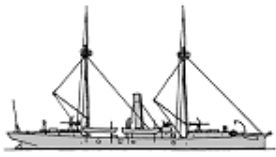
| | | | | | | | |
|----|----------------|---|-----|--|--|------------|--|
| | | | | |  | | |
| PR | Pedro d'Annaia | 3 | 1-3 | Pedro d'Annaia, Diogo Cão, Honório Barreto | 1895 | No picture | 93t, 30.0ppx6.0x0.8m, 500hp, 9kts; 2x1-47/40 |

© Ivan Gogin, 2014

[home](#)[World navies yesterday](#)[1900](#)

Romania 01 January 1900

CRUISERS

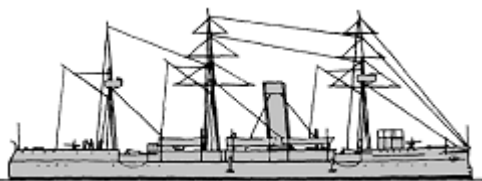
| | | | | | | | |
|----|-----------|---|---|-----------|------|---|--|
| CL | Elisabeta | 1 | 1 | Elisabeta | 1888 |  | 1300t, 73.0x10.2x3.7m, 4b,2vte, 4700hp, 17.3kts, 190p; steel-86slopes, 43deck; 4x1-149/32, 4x1-57/42, 4x1-37/20, 4-356TT |
|----|-----------|---|---|-----------|------|---|--|

TORPEDO SHIPS

| | | | | | | | |
|----|--------|---|-----|-----------------------|------|------------|--|
| TB | Năluca | 3 | 1-3 | Năluca, Sborul, Smeul | 1888 | No picture | 56t, 36.8x3.5x0.9m, 1b,1vc, 540hp, 16kts, 20p; 2x5-37/17, 2-356TT, 1spar torpedo |
|----|--------|---|-----|-----------------------|------|------------|--|

OTHER FIGHTING SHIPS

| | | | | | | | |
|----------|-------------------|------|-------------------------|---------------------------|------------|------------------------------------|--|
| PG | Grivița | 1 | 1 | Grivița | 1880 | No picture | 110t, 60.5x5.2x1.8m, 180hp, 9kts, 30p; 2x1-57/42, 2x1-37/42 |
| PGR | Rahova | 3 | 1-3 | Rahova, Smardan, Opanezul | 1882 | No picture | 45t, 8.5kts; 1x1-37/20 |
| | Oltul | 3 | 4 | Oltul | 1888 | No picture | 116t, 30.5x4.1x1.7m, 380hp, 13kts, 30p; 1x1-57/42, 1x1-37/42 |
| | | | 5 | Siretul | 1888 | | |
| | | | 6 | Bistrița | 1888 | | |
| | Alexandru cel Bun | 1 | 7 | Alexandru cel Bun | 1882 | No picture | 104t |
| Monteano | 3 | 8-10 | Monteano, Olteano, Imeo | 1893 | No picture | 95t, 13.5kts; 1x1-57/42, 2x1-37/42 | |



© Ivan Gogin, 2015





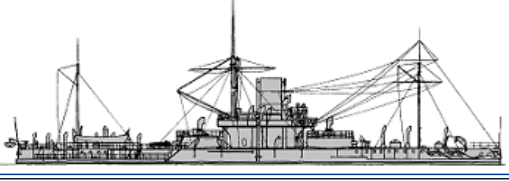
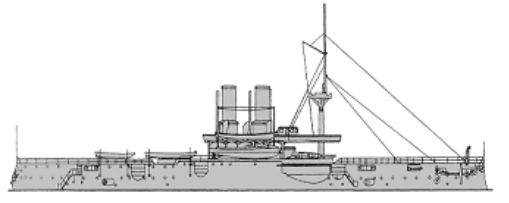
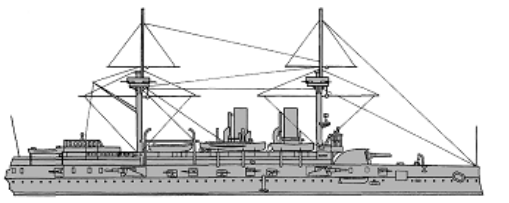
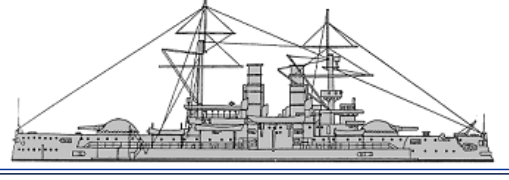
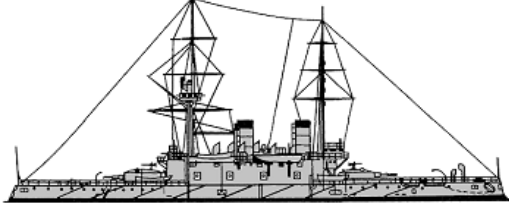
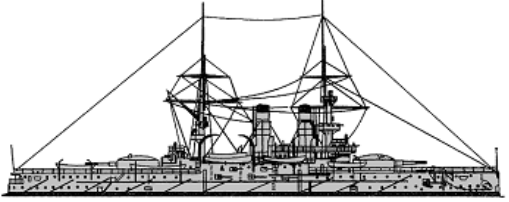
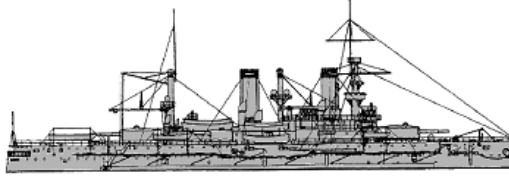

[home](#)[World navies yesterday](#)

1900

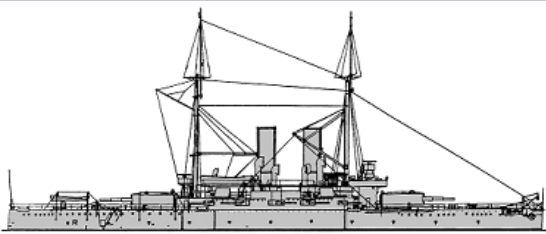
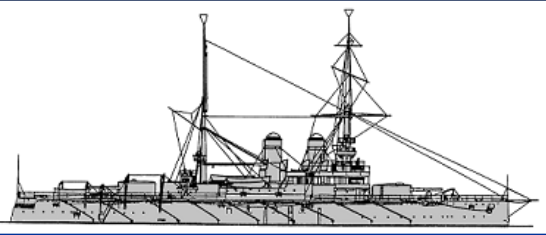
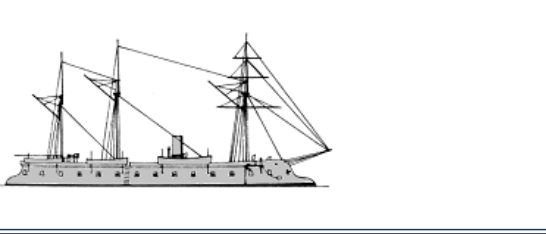
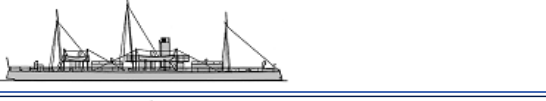
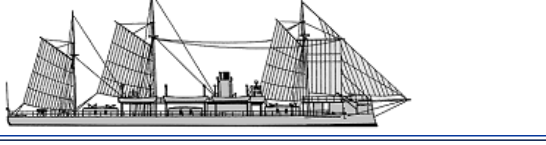
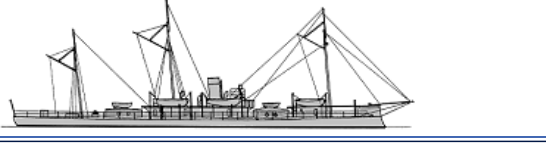
Russia 01 January 1900

BATTLESHIPS

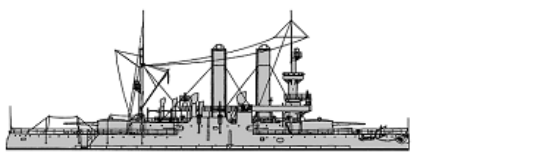
| | | | | | | | |
|-----------------|------------------------|----|-----------------|------------------------|--|--|--|
| BB | Pyotr Velikiy | 1 | 1 | Pyotr Velikiy | 1876 |  | 10460t, 103.5x19.0x8.3m, 12b,2vc, 8250hp, 14.3kts, 440p: iron- 356belt, 76deck, 356turrets; 2x2-305/17, 4x1-87/17, 6x1-47/40, 4x5-37/17, 2x4-25/40, 2-381TT |
| | Yekaterina II | 4 | 2 | Yekaterina II | 1888 |  | 11048(2)-10930(3)-10181(4)-10750(5)t, 103.5x21.0x8.8m, 14b,2vc(2,3)-16b,2vte(4,5), 9100(2,3)-13000(4,5)hp, 15(2,3)-16(4)-16.5(5)kts, 633-645p; compound(2-4)-steel(5), 406belt, 38(2)-57(3-5)deck, 305redoubt, 292(2-4)-305(5)CT; 3x2-305/27(2,4), 3x2-305/32(3,5), 7x1-152/32, 2x1-63/17(3-5), 8x1-47/40(5), 8x5-47/22(2-4), 10x1-37/20(5), 4x5-37/17(2-4), 7-381TT, 100mines |
| | | | 3 | Chesma | 1889 | | |
| | | | 4 | Sinop | 1889 | | |
| | | | 5 | Georgiy Pobedonosets | 1893 | | |
| | Imperator Aleksandr II | 2 | 6 | Imperator Aleksandr II | 1890 |  | 10010(6)-9672(7)t, 105.6x20.4x7.8m, 12b,2vc(6)-12b,2hte(7), 8500hp, 15.3kts, 616p; compound- 356belt, 63deck, 254barbette(6), 254turret(7), 254(6)-203(7)CT; 1x2-305/27, 4x1-229/32, 8x1-152/32, 4x1-63/17(6), 2x1-63/17(7), 10x5-47/22, 8x5-37/17, 5-381TT(6), 6-381TT(7) |
| | | | 7 | Imperator Nikolay I | 1891 | | |
| | Dvenadtsat Apostolov | 1 | 8 | Dvenadtsat Apostolov | 1892 |  | 8709t, 104.2x18.3x8.4m, 8b,2vte, 8750hp, 15.7kts, 599p; compound- 356belt, 63deck, 305barbettes, 203CT; 2x2-305/27, 4x1-152/32, 12x1-47/40, 10x1-37/20, 4x5-37/17, 6-381TT |
| | Navarin | 1 | 9 | Navarin | 1896 |  | 10206t, 109.0x20.4x8.4m, 12b,2vte, 9140hp, 15.5kts, 622p; compound- 406belt, 76deck, 305turrets, 254CT; 2x2-305/32, 8x1-152/32, 2x1-63/17, 8x1-47/40, 15x1-37/20, 6-381TT |
| Sisoy Velikiy | 1 | 10 | Sisoy Velikiy | 1896 |  | 10400t, 107.2x20.7x7.8m, 12b, 2vte, 8500hp, 15.7kts, 582p; NS- 406belt, 76deck, 305turrets, 203CT; 2x2-305/38, 6x1-152/44, 2x1-63/17, 12x1-47/40, 12x5-37/17, 6-381TT | |
| Poltava | 3 | 11 | Poltava | 1896 |  | 11500(11)-11354(12)-11842(13)t, 114.3x21.3x7.9m, 14b,2vte(11,12)-16b,2vte(13), 10600hp, 16.5kts, 652p; NS(12)-Harvey(13) 368(11,13)-406(12)belt, 76deck, 254turrets, 229CT; 2x2-305/38, (4x2+4x1)-152/44, 12x1-47/40(11,13), 10x1-47/40(12), 28x1-37/20, 2-450TT, 4-381TT, 50mines | |
| | | 12 | Petropavlovsk | 1897 | | | |
| | | 13 | Sevastopol | 1898 | | | |
| Tri Svyatitelya | 1 | 14 | Tri Svyatitelya | 1897 |  | 13318t, 115.1x22.3x8.7m, 14b,2vte, 11300hp, 753p; Harvey+NS- 457belt, 76deck, 406turrets, 305CT; 2x2-305/38, 14x1-152/44, 4x1-120/43, 2x1-63/17, 10x1-47/40, 10x1-37/20, 6-381TT | |

| | | | | | | | |
|---------------------|------------------|----|--------------------------|-------------------|--|---|--|
| | | | | |  | | |
| | Rostislav | 1 | 15 | Rostislav | 1898 |  | 10140t, 107.2x20.7x6.7m, 12b,2vte, 8700hp, 15.6kts, 632p; Harvey- 356belt, 76deck, 254turrets, 152CT; 2x2-254/43, 4x2-152/44, 2x1-63/17, 12x1-47/40, 14x1-37/20, 6-381TT |
| BC | Pervenets | 3 | 1 | Pervenets | 1863 |  | 4000t, 67.6(1)-69.4(2)-67.3(3)x16.2x4.6m, 2b,1hda(1)-4b,1hda(2,3), 1067(1)-1232(2)-870(3)hp, 8(1,2)-9(3)kts, 394-459p; iron- 114belt, 29deck(3), 114battery, 114CT(2,3); 6x1-203/19(1), 12x1-203/19(2), 8x1-203/19(3), 2x1-152/32(1), 4x1-152/25(1), 2x1-152/25(2), 7x1-152/32(3), 2x1-120/43(1), 1x1-107/17(1), 2x1-87/17(1), 2x1-63/17, 2x1-47/40(1), 4x1-47/40(3), 4x1-37/20(3), 5x5-37/17(1) |
| | | | 2 | Ne Tron Menya | 1865 | | |
| | | | 3 | Kreml | 1867 | | |
| | Smerch | 1 | 4 | Smerch | 1865 |  | 1460t, 57.4x11.6x3.7m, 2b,2hda, 700hp, 8kts, 155p; iron- 114side, 25deck, 152turrets; 2x1-229/19, 4x1-87/21, 4x5-37/17 |
| | Admiral Lazarev | 2 | 5 | Admiral Lazarev | 1869 |  | 3820(5)-3768(6)t, 77.7x13.1x6.2m, 4b,1hda, 2020hp, 10.5(5)-11(6)kts, 274p; iron- 114side, 114turrets, 127CT; 3x1-279/18, 2x1-63/17, 5x1-47/40, 2x1-37/20 |
| | | | 6 | Admiral Greyg | 1869 | | |
| | Admiral Spiridov | 2 | 7 | Admiral Spiridov | 1869 |  | 3925(7)-3851(8)t, 77.5x13.1x6.2m, 4b,1hda, 2030hp, 10.5kts, 260p; iron- 152side, 152(7)-178(8)turrets; 2x1-279/18, 2x1-63/17, 1x1-47/40, 4x1-37/20 |
| | | | 8 | Admiral Chichagov | 1869 | | |
| | Rusalka | 1 | 9 | Charodeyka | 1869 |  | 2100t, 62.9x12.8x3.8m, 2b,2hda, 875hp, 8.5kts, 178p; iron- 114side, 25deck, 152turrets; 2x2-229/19, 4x1-87/17, 5x5-37/17 |
| | Novgorod | 1 | 10 | Novgorod | 1874 |  | 2491t, 30.8x30.8x4.1m, 8b,4hc, 2000hp, 6kts, 149p; iron- 229sides, 70deck, 229barbette; 1x2-279/17, 2x1-87/17, 2x5-37/17 |
| Vitse-Admiral Popov | 1 | 11 | Vitse-Admiral Popov | 1876 |  | 3550t, 36.6x36.6x4.1m, 8b,4hc, 3066hp, 6kts, 203p; iron- 406sides, 76deck, 406barbette; 1x2-305/17, 6x1-87/17, 2x5-37/17 | |
| Admiral Ushakov | 3 | 12 | Admiral Ushakov | 1897 |  | 4648(12)-4792(13)-4152(14)t, 86.4x15.9x6.1m, 4b,2hte, 4250hp, 16(12,13)-15(14)kts, 406p; Harvey- 254belt, 51deck, 178turrets, 178CT; 2x2-254/43(12,13), (1x2+1x1)-254/43(14), 4x1-120/43, 2x1-63/17, 6x1-47/40(12,13), 10x1-47/40(14), 18x1-37/20(12,13), 12x1-37/20(14), 4-381TT | |
| | | 13 | Admiral Senyavin | 1897 | | | |
| | | 14 | General-Admiral Apraksin | 1899 | | | |
| MON | Bronenosets | 10 | 1 | Bronenosets | 1865 |  | 1565t, 61.3x14.0x3.8m, 2b,1hda, 340-530hp, 6.5-8kts, 111p; iron- 229side, 25(10)deck, 254turret, 203CT; 1x2-229/19, 2x1-47/40, 2x5-37/17 |
| | | | 2 | Uragan | 1865 | | |
| | | | 3 | Tifon | 1865 | | |
| | | | 4 | Veshchun | 1865 | | |
| | | | 5 | Koldun | 1865 | | |
| | | | 6 | Latnik | 1865 | | |
| | | | 7 | Edinorog | 1865 | | |
| | | | 8 | Strelets | 1865 | | |
| | | | 9 | Lava | 1865 | | |
| | | | 10 | Perun | 1865 | | |



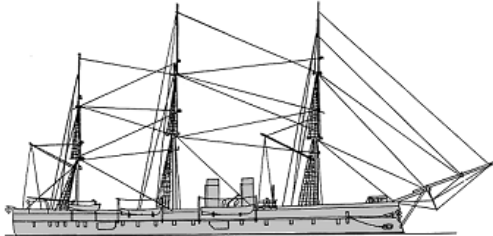
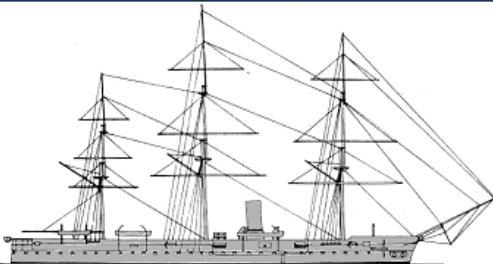
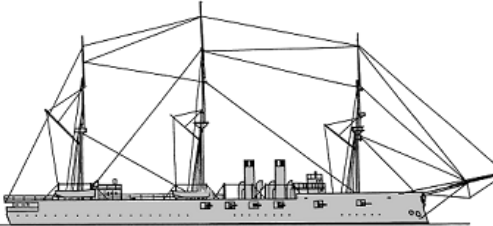
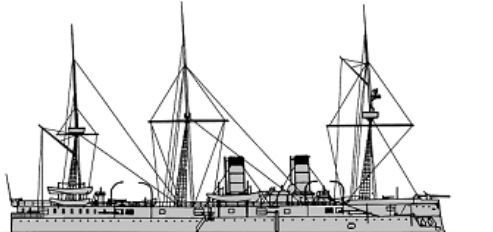
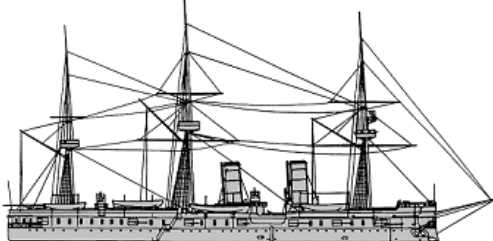
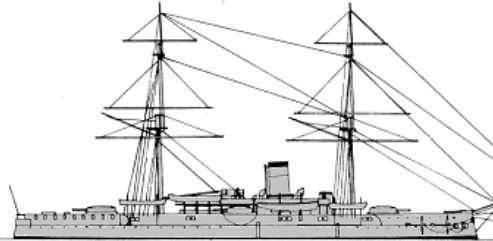
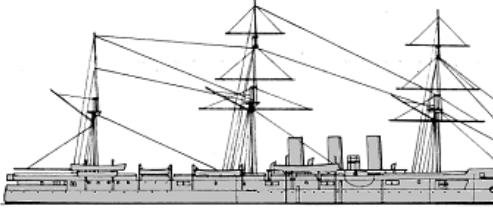

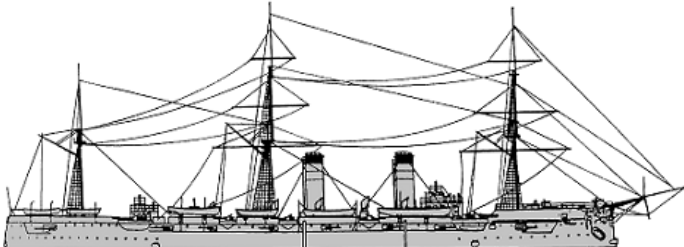
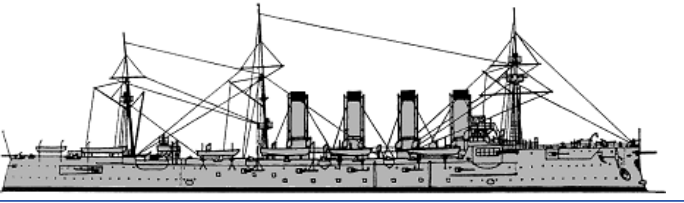
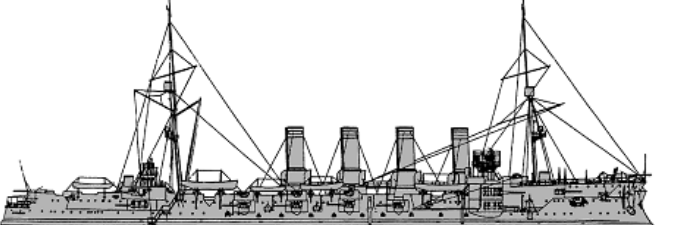
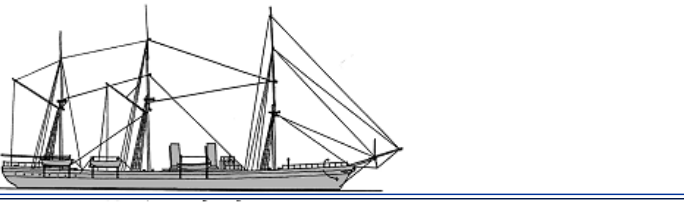
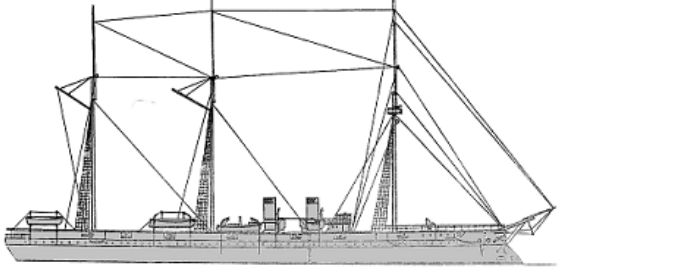
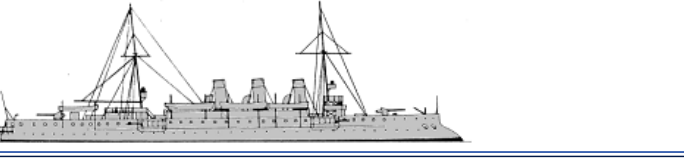
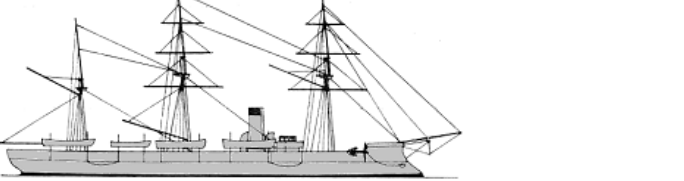
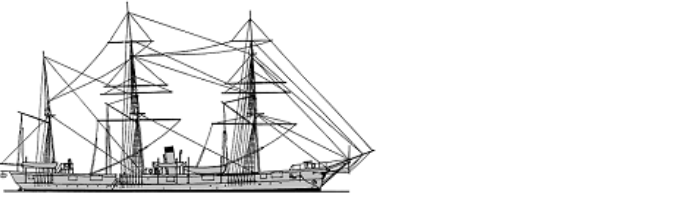
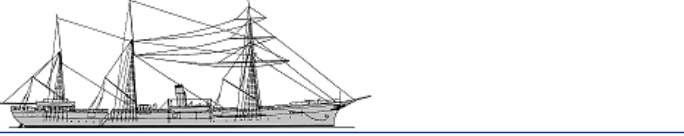

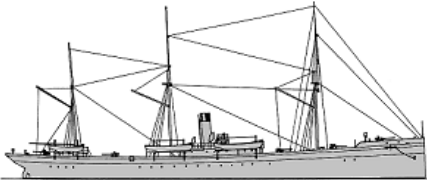



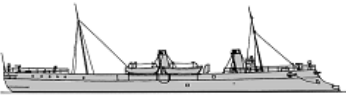
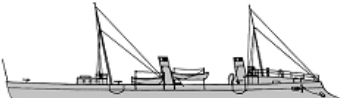
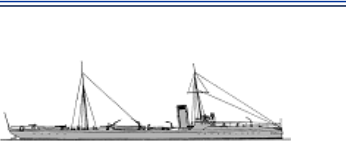







CRUISERS





















| | | | | | | | |
|----|-------------------|---|---|----------------------|------|---|---|
| CA | Knyaz Pozharskiy | 1 | 1 | Knyaz Pozharskiy | 1869 |  | 5138t, 83.1x14.9x7.5m, 8b,1hda, 2835hp, 11.7kts, 495p; iron- 102belt, 114battery; 2x1-203/19, 2x1-152/23, 4x1-87/17, 2x1-63/17, 2x1-47/40, 6x5-37/17 |
| | General-Admiral | 2 | 2 | General-Admiral | 1875 |  | 5031(2)-4838(3)t, 91.0(2)-86.9(3)x14.6x7.0(2)-7.3(3)m, 5b,1vc(2)-4b,1vc(3), 4470(2)-5222(3)hp, 12.3(2)-13.2(3)kts, 490p; iron- 152belt, 25deck; 4x1-203/28(3), 5x1-152/25(3), 4x1-152/23(2), 6x1-87/21, 6x1-47/40(2), 8x1-37/20(2), 10x5-37/17(3), 1-381TT(2), 3-381TT(3) |
| | | 3 | 3 | Gertsog Edinburgskiy | 1877 | | |
| | Minin | 1 | 4 | Minin | 1878 |  | 6136t, 89.9x15.1x7.7m, 18b,1vte, 4000hp, 12.2kts, 545p; compound- 178belt, 25deck; 4x1-203/28, 6x1-152/44, 4x1-87/17, 6x1-75/48, 2x1-63/17, 8x1-47/40, 2-381TT, 150mines |
| | Vladimir Monomakh | 1 | 5 | Vladimir Monomakh | 1883 |  | 6000t, 93.3x15.9x8.0m, 8b,2vc, 7000hp, 15.2kts, 566p; compound- 152belt, 13deck; 5x1-152/44, 6x1-120/43, 2x1-63/17, 16x1-47/40, 4x1-37/20, 3-381TT |
| | Dmitriy Donskoy | 1 | 6 | Dmitriy Donskoy | 1885 |  | 6200t, 93.4x15.9x7.9m, 8b,1vc, 7000hp, 16.5kts, 571p; compound- 152belt, 13deck; 6x1-152/44, 10x1-120/43, 2x1-63/17, 6x1-47/40, 10x1-37/20, 5-381TT |
| | Admiral Nakhimov | 1 | 7 | Admiral Nakhimov | 1888 |  | 8524t, 103.3x18.6x8.4m, 12b,2vc, 8000hp, 17kts, 570p; compound- 254belt, 76deck, 203barbettes, 152CT; 4x2-203/33, 10x1-152/32, 2x1-63/17, 12x1-47/40, 6x1-37/20, 3-381TT, 40mines |
| | Pamyat Azova | 1 | 8 | Pamyat Azova | 1890 |  | 6674t, 117.2x17.2x8.2m, 6b,2vte, 8500hp, 17kts, 640p; compound- 152belt, 63deck, 51shields, 38CT; 2x1-203/33, 13x1-152/32, 2x1-63/17, 7x1-47/40, 8x5-37/17, 3-381TT |
| | Ryurik | 1 | 9 | Ryurik | 1895 | | 11690t, 132.6x20.4x7.9m, 8b,2vte, 13250hp, 18kts, 683p; steel- 254belt, 76deck, 51shields, 152CT; 4x1-203/33, 16x1-152/44, 6x1-120/43, 2x1-63/17, 10x1-47/40, 12x5-37/17, 6-381TT |

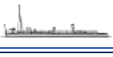

| | | | | | | |
|-----|------------------|------|------------------|------|--|---|
| | | | | |  | |
| | Rossiya | 1 10 | Rossiya | 1897 |  | 12195t, 147.8x20.9x7.9m, 32b,3vte, 17000hp, 19.7kts, 839p; Harvey-203belt, 76deck, 127casemates, 305CT; 4x1-203/43, 16x1-152/44, 12x1-75/48, 20x1-47/40, 18x1-37/20, 5-381TT |
| | Gromoboy | 1 11 | Gromoboy | 1899 |  | 12455t, 146.6x20.9x7.9m, 32b,3vte, 14500hp, 19kts, 874p; 152belt, 76deck, 127casemates, 305CT; 4x1-203/43, 16x1-152/44, 24x1-75/48, 12x1-47/40, 18x1-37/20, 4-381TT |
| CL | Vityaz | 1 1 | Rynda | 1886 |  | 3537t, 79.4x13.7x5.3m, 10b,1hc, 3000hp, 11.5kts, 396p; steel-38deck; 4x1-152/25, 4x1-87/21, 2x1-47/40, 6x5-37/17, 1-381TT |
| | Admiral Kornilov | 1 2 | Admiral Kornilov | 1888 |  | 5880t, 112.2x14.8x7.8m, 8b,2hte, 5977hp, 17.6kts, 479p; steel-63deck, 76CT; 14x1-152/32, 6x1-47/40, 10x5-37/17, 6-381TT |
| | Svetlana | 1 3 | Svetlana | 1898 |  | 3862t, 101.0x13.0x5.7m, 18b,2vte, 8500hp, 21.6kts, 401p; NS-63slopes, 38deck, 102CT; 6x1-152/44, 10x1-47/40, 2-381TT, 20mines |
| CLL | Pamyat Merkuriya | 1 1 | Pamyat Merkuriya | 1880 |  | 2997t, 90.0x12.4x6.0m, 6b,1hc, 3000hp, 14kts, 343p; 6x1-152/25, 2x1-63/17, 4x1-47/40, 2x1-37/20, 2x5-37/17, 2-381TT, 180mines |
| SL | Kreyser | 1 | Kreyser | 1876 |  | 1334-1449t, 70.5x10.0-10.1x5.1m, 4b,1hc, 1383-1786hp, 10-13.5kts, 188-199p; 2x1-152/25(1,2), 1x1-152/25(4,6), 3x1-152/25(5,7,8), 2x1-152/23(3,4,6), 4x1-107/17(1-3), 4x1-87/21(4,6-8), 2x1-87/21(5), 1x1-63/17(1-3,6-8), 2x1-44/41(1,2), 4x1-44/41(3), 4x5-37/17(1,2), 6x5-37/17(3,6-8), 7x5-37/17(4), 1x5-37/21(5), 1-381TT(1,3,5-8), 2-381TT(4) |
| | | 2 | Dzhigit | 1877 | | |
| | | 3 | Razboynik | 1879 | | |
| | | 4 | Naezdnik | 1879 | | |
| | | 5 | Plastun | 1879 | | |
| | | 6 | Strelok | 1880 | | |
| | | 7 | Vestnik | 1881 | | |
| | | 8 | Oprichnik | 1881 | | |
| | Zabiyaka | 1 9 | Zabiyaka | 1879 |  | 1236t, 67.0ppx9.1x4.0m, 2b,1vc, 1426hp, 14.2kts, 155p; 2x1-152/25, 4x1-107/17, 1x1-63/17, 4x1-47/40, 6x5-37/17 |
| | | | | | 2449t, 82.0x10.7xm, 1100hp, | |

| | | | | | | |
|-----|---|---|--------|------|---|--|
| AMC | - | 1 | Aziya | 1874 |  | 15.6kts; 2x1-152/23, 7x1-107/17 |
| | | 2 | Afrika | 1878 | | 2590t, 90.2x10.9xm, 1417hp, 12.8kts; 5x1-152/23, 4x1-107/17, 2x1-87/21 |

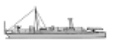

TORPEDO SHIPS

| | | | | | | | |
|--------|-----------------|------|----------|-----------------|---|--|---|
| PGT | Leytenant Ilyin | 1 | 1 | Leytenant Ilyin | 1887 |  | 714t, 72.3x7.4x3.2m, 6b,2vte, 3500hp, 20.8kts, 128p; steel- 19deck; 7x1-47/40, 6x5-47/22, 6x5-37/17, (5+2x1)-381TT |
| | Kapitan Saken | 1 | 2 | Kapitan Saken | 1889 |  | 742t, 71.6x7.4x3.1m, 6b,2vte, 3000hp, 18.3kts, 102p; steel- 13deck; 6x1-47/40, 4x5-37/17, (1+2x1)-381TT |
| | Kazarskiy | 6 | 3 | Kazarskiy | 1890 |  | 432t, 60.2x7.4x3.5m, 2b,1vte, 3500hp, 21-22.5kts, 65p; 6x1-47/40, 3x1-37/20, (1+1x1)-381TT |
| | | | 4 | Voevoda | 1892 | | |
| | | | 5 | Posadnik | 1892 | | |
| | | | 6 | Vsadnik | 1894 | | |
| 7 | | | Gaydamak | 1894 | | | |
| 8 | Griden | 1895 | | | | | |
| Abrek | 1 | 9 | Abrek | 1897 |  | 675t, 65.5x7.8x3.4m, 4b,2vte, 4500hp, 21.2kts, 88p; 2x1-75/48, 4x1-47/40, (1+1x1)-450TT | |
| DD | Sokol | 1 | 1 | Sokol | 1895 |  | 240t, 57.9x5.6x2.3m, 8b,2vte, 3800hp, 29kts, 54p; 1x1-75/48, 3x1-47/40, 2x1-381TT |
| | Vzryv | 1 | 1 | Vzryv | 1877 |  | 160t, 39.6x4.9x3.4m, 2b,1vc, 800hp, 13.5kts, 33p; 4x5-37/17, 2-381TT |
| | Batum | 1 | 2 | No251 | 1880 |  | 48t, 30.6x3.7x1.9m, 1b,1vc, 500hp, 15.2kts, 21p; 2x5-37/17, 2-381TT |
| | Sukhum | 1 | 3 | No257 | 1883 |  | 64t, 34.4x3.8x2.0m, 1b,1vc, 704hp, 17.9kts, 16p; 2x5-37/17, 2-381TT |
| | Poti | 1 | 4 | No258 | 1883 |  | 63t, 38.0x3.1x2.0m, 1b,1vc, 575hp, 18.5kts, 18p; 2x5-37/17, 2-381TT |
| | Gagry | 1 | 5 | No254 | 1884 |  | 80t, 36.8x4.1x2.0m, 1b,1vc, 600hp, 17.8kts, 18p; 1x1-37/20, 1x5-37/17, 2-381TT |
| | Gelendzhik | 1 | 6 | No255 | 1884 |  | 75t, 37.4x3.8x2.1m, 1b,1vc, 520hp, 18kts, 16p; 1x1-37/20, 1x5-37/17, 2-381TT |
| | No1 | 1 | 7 | No101 | 1885 |  | 68t, 38.8x3.9x1.4m, 1b,2vc, 472hp, 16.5kts, 21p; 2x5-37/17, 2-381TT |
| | No17 | 3 | 8-10 | No106, 107, 267 | 1886-1888 |  | 74(8,9)-77(10)t, 38.9x3.5x2.3m, 1b,1vc, 296(8,9)-520(10)hp, 15.8(8,9)-17.5(10)kts, 21p; 4x5-37/17(8,9), 2x5-37/17(10), 2-381TT |
| | Sveaborg | 2 | 11 | No205 | 1886 |  | 96(11)-108(12)t, 46.8x3.4(11)-3.7(12)x2.6(11)-2.5(12)m, 1b,1vte, 737(11)-837(12)hp, 19.2(11)-19.7(12)kts, 21p; 2x5-37/17, 2-381TT |
| | | | 12 | No206 | 1886 | | |
| | Vyborg | 1 | 13 | No102 | 1886 |  | 150t, 45.1x5.2x2.1m, 2b,2vc, 1300hp, 20kts, 24p; 2x5-37/17, 2-381TT |
| | Abo | 3 | 14-16 | No108-110 | 1886 |  | 76t, 38.5x4.5x1.9m, 1b,1vc, 640hp, 19.3-20kts, 21p; 4x5-37/17, 2-381TT |
| | Yalta | 6 | 17-22 | No261-266 | 1886 |  | 85-90t, 38.6x4.6x2.0m, 1b,1vte, 900hp, 20-20.8kts, 18p; 2x5-37/17, 2-381TT |
| | Yanchikhe | 2 | 23, 24 | No201, 202 | 1889 |  | 76t, 39.0x4.5x1.9m, 1b,1vc, 970hp, 16.8-17.2kts, 21p; 2x5-37/17, 2-381TT |
| | Adler | 1 | 25 | No259 | 1890 |  | 164t, 46.9x5.1x2.0m, 2b,2vte, 2000hp, 26.7kts, 25p; 2x5-37/17, (1+2x1)-381TT |
| | Anakriya | 1 | 26 | No260 | 1890 |  | 100t, 38.6x4.8x2.1m, 2b,1vte, 1100hp, 21kts, 21p; 2x5-37/17, (1+1x1)-381TT |
| Nargen | 2 | 27 | No203 | 1891 |  | 153t, 47.3x5.0x2.6m, 2b,2vte, 2039(27)-1956(28)hp, 19.5(27)-20.3(28)kts, 21p; 3x5-37/17, (1+2x1)-381TT | |
| | | 28 | No204 | 1891 | | | |

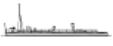
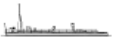
| | | | | | | | |
|-------------|-------------|----|--------|--|---|---|---|
| TB | Biorke | 4 | 29-32 | No111-114 | 1891-1892 |  | 81t, 38.4x4.5x2.6m, 1b,1vte, 1000-1100hp, 17.8-19kts, 21p; 2x5-37/17, 2x1-381TT |
| | Borgo | 2 | 33 | No207 | 1891 |  | 118t, 41.7x4.5x2.6m, 1b,1vte, 1245hp, 20kts, 21p; 2x5-37/17, (1+1x1)-381TT |
| | | | 34 | No117 | 1891 | | |
| | Anapa | 2 | 35, 36 | No252, 253 | 1891-1892 |  | 96t, 38.4x4.5x2.6m, 1b,1vte, 1000-1100hp, 17.2-19kts, 18p; 2x5-37/17, 2x1-381TT |
| | Dago | 4 | 37 | No118 | 1892 |  | 101-105t, 46.5-46.8x3.9x2.3-2.6m, 1b,1vte, 1000-1030hp, 16.2-19kts, 21p; 2x5-47/22(37), 2x5-37/17(38-40), (1+1x1)-381TT |
| | | | 38 | No256 | 1892 | | |
| | | | 39 | No123 | 1892 | | |
| | | | 40 | No124 | 1892 | | |
| | Pernov | 1 | 41 | No103 | 1892 |  | 120t, 42.0x4.5x2.1m, 2b,2vte, 2000hp, 26kts, 21p; 2x5-37/17, (1+2x1)-381TT |
| | Tosna | 2 | 42, 43 | No115, 116 | 1893 |  | 85-87t, 38.7x4.6x2.0m, 1b,1vte, 1000hp, 20kts, 21p; 2x5-47/22, (1+1x1)-381TT |
| | Aspe | 4 | 44 | No121 | 1895 |  | 105t, 38.8x4.8x2.1m, 2b,1vte, 1300hp, 20kts, 21p; 2x5-37/17, (1+1x1)-381TT |
| | | | 45 | No122 | 1895 | | |
| | | | 46 | No125 | 1894 | | |
| 47 | | | No126 | 1894 | | | |
| Sestroretsk | 1 | 48 | No104 | 1894 |  | 80t, 36.8x4.2x2.6m, 1b,1vte, 1300hp, 23kts, 21p; 2x5-37/17, (1+1x1)-381TT | |
| No119 | 19 | 49 | No119 | 1895 |  | 120t, 42.0x4.5x2.1m, 2b,2vte, 2000hp, 19.5-23.2kts, 21p; 2x5-37/17, (1+2x1)-381TT | |
| | | 50 | No120 | 1895 | | | |
| | | 51 | No127 | 1898 | | | |
| | | 52 | No128 | 1898 | | | |
| | | 53 | No129 | 1899 | | | |
| | | 54 | No133 | 1897 | | | |
| | | 55 | No134 | 1897 | | | |
| | | 56 | No135 | 1897 | | | |
| | | 57 | No136 | 1897 | | | |
| | | 58 | No137 | 1897 | | | |
| | | 59 | No138 | 1897 | | | |
| | | 60 | No139 | 1897 | | | |
| | | 61 | No140 | 1897 | | | |
| | | 62 | No141 | 1897 | | | |
| | | 63 | No142 | 1897 | | | |
| | | 64 | No270 | 1897 | | | |
| | | 65 | No271 | 1897 | | | |
| | | 66 | No272 | 1899 | | | |
| | | 67 | No273 | 1899 | | | |
| No131 | 3 | 68 | No131 | 1897 |  | 100t, 38.7x5.2x2.0m, 2b,2vte, 1000hp, 21kts, 18p; 2x5-37/17, (1+1x1)-381TT | |
| | | 69 | No132 | 1896 | | | |
| | | 70 | No268 | 1895 | | | |
| No208 | 3 | 71 | No208 | 1899 |  | 130t, 42.0x4.5x2.1m, 2b,2vte, 1460hp, 18.5kts, 21p; 2x5-37/17, (1+2x1)-381TT | |
| | | 72 | No209 | 1899 | | | |
| | | 73 | No210 | 1899 | | | |
| TB2cl | No2 | 1 | 1 | No88 | 1874 |  | 25t, 22.9x3.1x1.5m, 1b,1hda, 112hp, 14kts; 1x1-381TT |
| | No5 | 1 | 2 | No89 | 1877 |  | 11t, 19.8x2.6x0.6m, 1b,1vte, 120hp, 16kts, 9p; 1x1-381TT |
| | Vorona | 1 | 3 | No151 | 1877 |  | 23t, 22.9x2.6x1.1m, 1b,1vc, 220hp, 12kts, 11p; 1x1-381TT |
| | Oryol | 70 | 4-73 | No1-12, 15, 17-22, 25-40, 42-73, 95, 97, 143 | 1877-1878 |  | 23t, 21.7x2.7x1.7m, 1b,1vc, 220hp, 16kts, 7p; 1x1-381TT |
| | Kefal | 1 | 74 | No90 | 1877 |  | 13t, 17.4x2.3x0.9m, 1b,1hda, 90hp, 12kts, 9p; 1x1-381TT |
| | Chizhik | 4 | 75-78 | No82, 91-93 | 1877-1878 |  | 23t, 21.7x3.0x1.1m, 1b,1vc, 220hp, 16kts, 9p; 1x1-381TT |
| | Galka | 1 | 79 | No13 | 1878 |  | 34t, 22.1x3.1x1.6m, 1b,1vc, 220hp, 13kts, 9p; 1x1-381TT |
| | Kasatka | 1 | 80 | No14 | 1878 |  | 28t, 21.8x3.0x1.9m, 1b,1vc, 312hp, 13kts, 9p; 1x1-381TT |
| | Podorozhnik | 1 | 81 | No94 | 1878 |  | 20t, 21.5x2.8x0.8m, 1b,1vc, 200hp, 14kts, 9p; 1x1-381TT |
| | Selezen | 1 | 82 | No41 | 1878 |  | 33t, 22.7x3.4x1.8m, 1b,1vc, 200hp, 13kts, 9p; 1x1-381TT |
| | Mech | 4 | 83-86 | No75, 76, 78, 81 | 1878 |  | 20t, 20.1x3.4x1.3m, 1b,1vte, 260hp, 15kts, 9p; 1x1-381TT |

| | | | | | | |
|-----------|---|--------|----------|------|---|--|
| Samopal | 2 | 87, 88 | No23, 24 | 1878 |  | 30t, 25.6x3.3x1.9m, 1b,1vc, 250hp, 15kts, 8p; 1x1-381TT |
| Shchuka | 3 | 89-90 | No83-85 | 1878 |  | 24t, 22.9x3.1x1.4m, 1b,1hda, 220hp, 16kts, 9p; 1x1-381TT |
| Skumbriya | 2 | 91, 92 | No86, 87 | 1878 |  | 31t, 20.0x3.2x1.1m, 1b,1hda, 220hp, 13.5kts, 9p; 1x1-381TT |
| Sirena | 1 | 93 | No16 | 1879 |  | 29t, 25.3x3.4x0.9m, 1b,1vc, 220hp, 14.5kts, 9p; 1x1-381TT |
| Skorpion | 1 | 94 | No96 | 1879 |  | 31t, 19.2x3.1x1.2m, 1b,1hda, 220hp, 14kts, 9p; 1x1-381TT |
| No46 | 1 | 95 | No74 | 1889 |  | 15t, 18.2x2.6x1.3m, 1b,1vc, 200hp, 16.5kts; 1x4-25/41, 1x1-381TT |

OTHER FIGHTING SHIPS

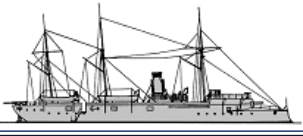
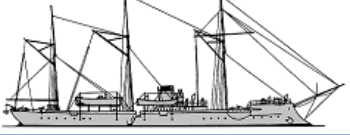
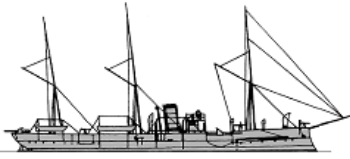
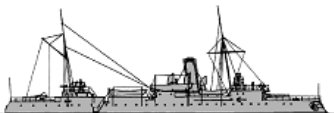
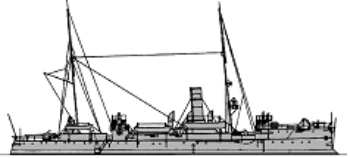
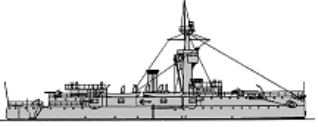
| | | | | | | | |
|--------------|----------|----|--------------|----------|---|---|--|
| PG | Opyt | 1 | 1 | Mina | 1862 | No picture | 270t, 37.7x6.8x1.8m, 1b,2hp, 195hp, 9kts, 28p; iron- 114breastwork; 2x1-87/17 |
| | Pishchal | 1 | 2 | Pishchal | 1872 | No picture | 346t, 40.8x7.7x2.2m, 1b,1hda, 172hp, 8kts, 48p; 6x1-87/17 |
| | Yorsh | 1 | 3 | Yorsh | 1875 |  | 321t, 30.1x8.7x2.2m, 2b,2hc, 240hp, 8kts, 44p; 1x1-279/17, 2x1-44/41 |
| | Burun | 4 | 4 | Burun | 1880 |  | 424(4-6)-383(7)t, 36.4x8.8x2.4m, 2b,2hc, 240-283hp, 7.5kts, 54p; 1x1-279/18(6), 3x1-107/17(5), 6x1-107/17(7), 4x1-87/21(4), 5x1-87/21(5), 2x1-75/48(7), 3x1-37/20(4), 2x1-37/20(6,7) |
| | | 5 | 5 | Tucha | 1880 | | |
| | | 6 | 6 | Burya | 1881 | | |
| | | 7 | 7 | Groza | 1881 | | |
| | Dozhd | 4 | 8 | Dozhd | 1880 |  | 402(8,10,11)-390(9)t, 33.5x10.5(8,10,11)-11.6(9)x2.2m, 2b,2hc, 300(8,10,11)-445(9)hp, 9-9.3kts, 54p; 1x1-279/17(9,11), 1x1-279/18(10), 6x1-37/20(8), 2x1-37/20(9-11) |
| | | 9 | 9 | Vikhr | 1880 | | |
| | | 10 | 10 | Grad | 1881 | | |
| | | 11 | 11 | Sneg | 1881 | | |
| | Sivuch | 2 | 12 | Sivuch | 1884 |  | 1134(12)-1187(13)t, 60.3x10.7x3.5(12)-3.7(13)m, 6b,2hc, 1100hp, 11kts, 188p; steel- 13deck; 1x1-229/27, 1x1-152/25, 6x1-107/17, 1x1-63/17, 4x5-37/17 |
| | | 13 | 13 | Bobr | 1886 | | |
| | Koreets | 2 | 14 | Koreets | 1887 |  | 1334(14)-1418(15)t, 66.3(14)-66.6(15)x10.7x3.5(14)-3.8(15)m, 6b,2hc, 1500hp, 13kts, 179p; 2x1-203/33, 1x1-152/32, 4x1-107/17, 1x1-63/17, 2x1-47/40, 4x5-37/17, 1-381TT |
| | | 15 | 15 | Mandzhur | 1887 | | |
| Kubanets | 6 | 16 | Kubanets | 1887 |  | 1505t, 67.2(16-18)-64.5(19-21)x12.2x3.8m, 6b,2hc(16-18)-6b,2hte(19-21), 1500hp, 11-14kts, 180p; 2x1-203/33, 1x1-152/32, 6x5-47/22, 2-381TT | |
| | 17 | 17 | Terets | 1887 | | | |
| | 18 | 18 | Uralets | 1888 | | | |
| | 19 | 19 | Zaporozhets | 1888 | | | |
| | 20 | 20 | Chernomorets | 1889 | | | |
| Grozyashchiy | 3 | 22 | Grozyashchiy | 1892 |  | 1627(22)-1700(23)-1854(23)t, 72.3x12.7x4.0(22,23)-4.4(24)m, 6b,2vte, 2050(22,23)-2500(24)hp, 14-14.5kts, 178-188p; steel- 127belt, 38deck, 25CT; 1x1-229/32, 1x1-152/32, 6x1-47/40, 4x5-37/17, 2-381TT, 20mines | |
| | 23 | 23 | Gremyashchiy | 1893 | | | |
| | 24 | 24 | Otvazhny | 1893 | | | |
| Khrabry | 1 | 25 | Khrabry | 1897 |  | 2100t, 72.3x12.7x3.8m, 8b, 2vte, 2100hp, 14kts, 188p; 2x1-203/43, 1x1-152/44, 5x1-47/40, 4x1-37/20, 1-450TT, 20mines | |
| Gilyak | 1 | 26 | Gilyak | 1899 |  | 1251t, 63.1x11.1x3.3m, 6b,2vte, 1000hp, 12kts, 170p; steel- 13deck; 1x1-120/43, 5x1-75/48, 2x1-63/17, 4x1-47/40, 2x1-37/20, 1-450TT | |

MINE WARFARE SHIPS

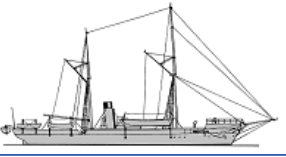
| | | | | | | | |
|----|-------|---|---|-------|------|---|--|
| ML | Aleut | 1 | 1 | Aleut | 1886 |  | 892t, 49.4x9.4x3.5m, 2b,1vc, 730hp, 11.9kts, 100p; 4x5-37/17, 250mines |
| | | | 2 | Bug | 1892 | | |

| | | | | | | |
|-----|---|---|-------|------|--|--|
| Bug | 2 | 3 | Dunay | 1893 |  | 1490t, 62.2x10.4x4.6m, 4b,2vte, 1400hp, 13kts, 226p; 4x1-47/40, 545mines |
|-----|---|---|-------|------|--|--|

BOARD GUARD SHIPS

| | | | | | | | |
|----|---------|---|-----|--|------|------------|--|
| CG | Roksana | 1 | 1 | Roksana | 1893 | No picture | 157t, 37.0x4.2x2.0m, 2b,1vte, 600hp, 12kts; 2x5-37/17 |
| | Oryol | 1 | 2 | Oryol | 1898 | No picture | 125t, 35.1x5.2x2.4m, 250hp, 12kts, 28p; 2x1-37/20 |
| CB | Gagara | 5 | 1-5 | Gagara, Krechet, Lastochka, Lebed, Nyrok | 1873 | No picture | 35t, 21.3x4.0x1.4m, 1vc, 45hp, 10kts, 13p; 1x1-87/17 |
| | Strazh | 2 | 1 | Strazh | 1874 | No picture | 230t, 33.0x6.4x2.5m, 1vc, 300hp, 11kts, 36p; 1x1-87/17 |
| | | | 2 | Chasovoy | 1874 | | |

Google™
Custom Search

© Ivan Gogin, 2014

[home](#)

[World navies yesterday](#)

[1900](#)

Sarawak 01 January 1900

OTHER FIGHTING SHIPS

| | | | | | | | |
|----|-------------|---|---|-------------|------|------------|--|
| PG | Aline | 1 | 1 | Aline | 1875 | No picture | 175brt, 43.4x6.5m, 35hp; 2x1-small guns |
| | Lorna Doone | 1 | 2 | Lorna Doone | 1881 | No picture | 118brt, 31.5x5.2m, 40hp, 2x1-small guns |
| | Aden | 1 | 3 | Aden | 1884 | No picture | 300brt, 45.6x7.7m, (sw), 75hp; 1x1-small gun |

© Ivan Gogin, 2015

[home](#)[World navies yesterday](#)[1900](#)

Siam 01 January 1900

CRUISERS

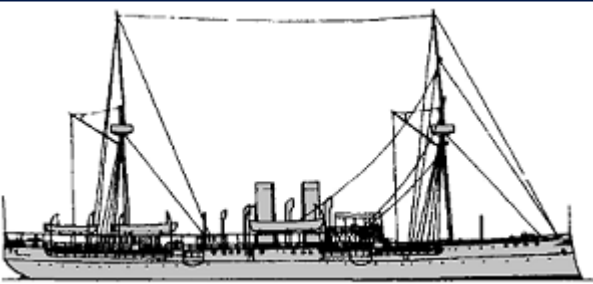
| | | | | | | | |
|----|-------------|---|---|-------------|------|--|---|
| CL | Maha Chakri | 1 | 1 | Maha Chakri | 1893 |  | 2500t, 88.4x12.0x4.2m, 5b,2vte, 3000hp, 15kts, 318p; steel-51deck; 4x1-120/40, 10x1-57/40 |
|----|-------------|---|---|-------------|------|--|---|

TORPEDO SHIPS

| | | | | | | | |
|----|----------|---|---|----------|------|------------|---|
| TB | Moradoph | 1 | 1 | Moradoph | 1888 | No picture | 45t, 22.0x2.8x1.5m, 1b,1hda, 35hp, 10kts; 1spar torpedo |
|----|----------|---|---|----------|------|------------|---|

OTHER FIGHTING SHIPS

| | | | | | | | |
|----|----------------------|---|----|----------------------|------|------------|---|
| PG | Yong Yot | 1 | 1 | Yong Yot | 1863 | No picture | 450t, 44.2x6.5x3.4m, 10kts; 6x1-134/14, 1x1-121/22 |
| | Nirben | 1 | 2 | Nirben | 1866 | No picture | 290t, 40.6x5.3x2.9m, 9kts; 1x1-102/14, 6x1-small guns |
| | Han Hak Sakru | 1 | 3 | Han Hak Sakru | 1866 | No picture | 260t, 26.8x7.9x2.0m, 7kts; 1x1-102/27 |
| | Maida | 1 | 4 | Maida | 1867 | No picture | 370t, 41.8x5.9x3.1m, 11kts; 1x1-121/21 |
| | Kralalahome | 1 | 5 | Kralalahome | 1867 | No picture | 278brt, 44.1x6.8m, 60hp |
| | Phitthayamronnayut | 1 | 6 | Phitthayamronnayut | 1868 | No picture | 660t, 50.6x7.9x3.2m, 9kts; 4x1-134/12, 1x1-121/22, 2x1-95/21 |
| | Murathavasitsawat | 1 | 7 | Murathavasitsawat | 1873 | No picture | 580t, 45.8x7.6x3.4m, 10kts; 1x1-163/16, 2x1-76/19 |
| | Vara Rattana Phichai | 1 | 8 | Vara Rattana Phichai | 1875 | No picture | 450t, 54.3x6.8x2.4m, 10kts |
| | Ranrukpahairi | 1 | 9 | Ranrukpahairi | 1879 | No picture | 450t, 38.4x7.9x3.5m, 540hp, 11kts; 4x1-121/22, 1x1-57/27 |
| | Mongkut Rajakumarn | 1 | 10 | Mongkut Rajakumarn | 1887 | No picture | 700t, 53.3x7.2x3.4m, 2b,2vte, 800hp, 14kts, 100p; 2x1-120/40, 4x1-57/40, 3x1-37/20, 1-356TT |
| | Koh Si Chang | 1 | 11 | Koh Si Chang | 1890 | No picture | 100t |

| | | | | | | | |
|----|-----------------|---|----|-----------------|------|--|---|
| | Udhai Rajakich | 1 | 12 | Udhai Rajakich | 1890 | No picture | 134t |
| | Sathit Rajakarn | 1 | 13 | Sathit Rajakarn | 1892 | No picture | |
| | Theva Sooraram | 1 | 14 | Theva Sooraram | 1898 | No picture | 115t |
| | Muratha | 1 | 15 | Muratha | 1898 |  | 530t, 44.2x7.0x3.1m, 2b,2vte, 500hp, 11.4kts, 83p; 1x1-120/40, 5x1- 57/40, 4x1-37/20 |
| FB | Siam Mongkut | 1 | 1 | Siam Mongkut | 1870 | No picture | 950t, 64.0m; iron- 63battery; 8x1-102/21 |
| DV | Prap Porapak | 1 | 1 | Prap Porapak | 1898 | No picture | 210t |

© Ivan Gogin, 2015



[home](#)[World navies yesterday](#)[1900](#)

Spain 01 January 1900

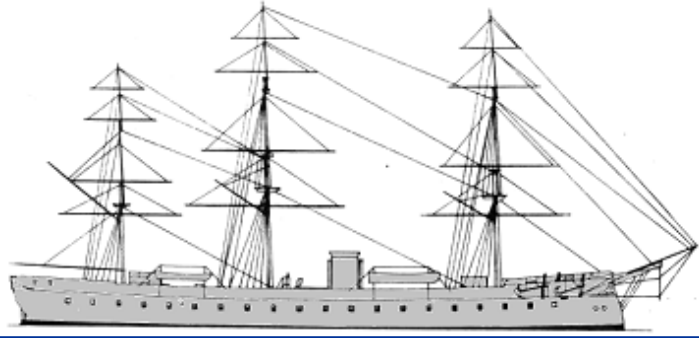
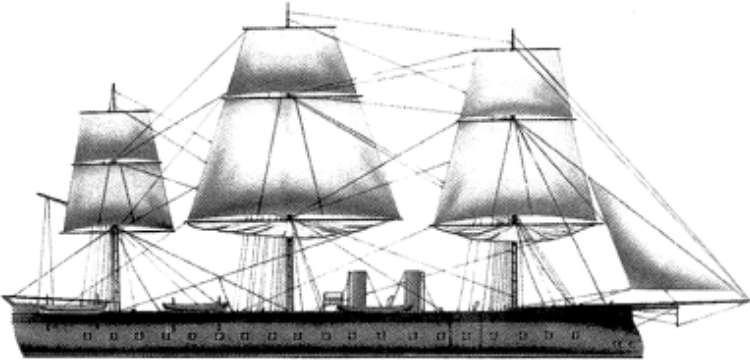
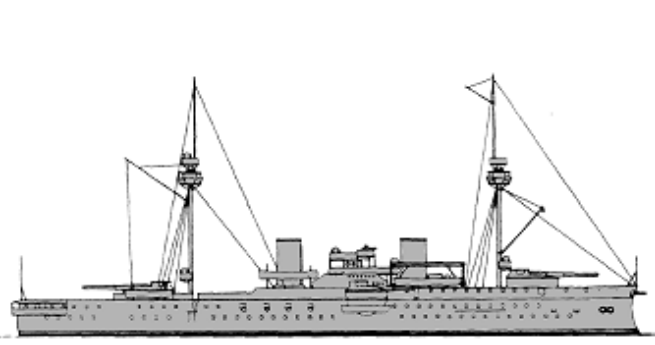
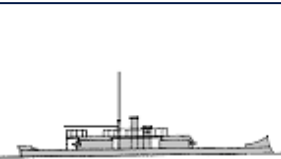
BATTLESHIPS



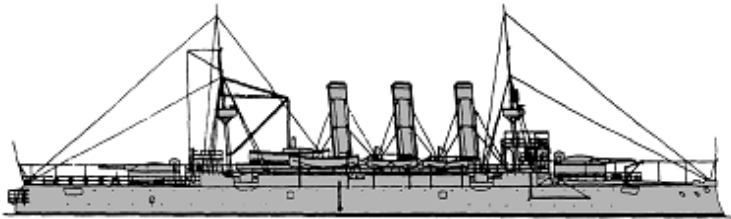

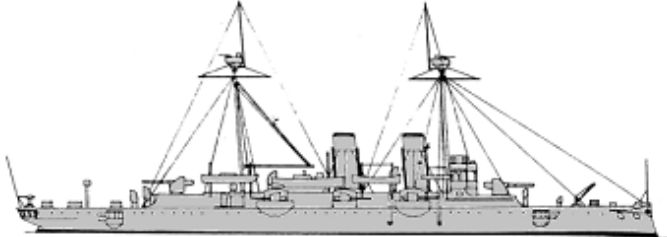
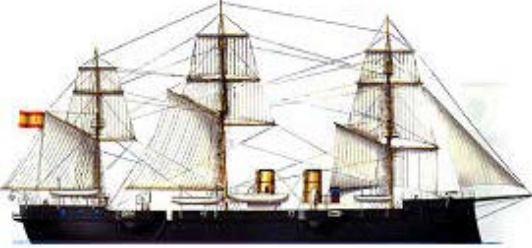
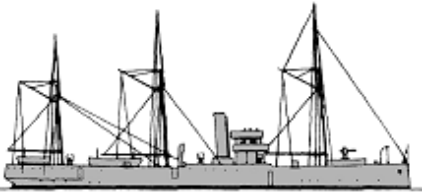
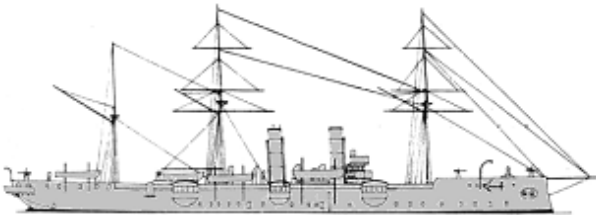





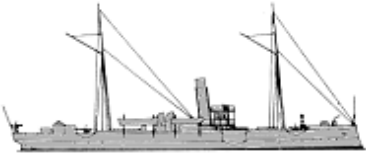

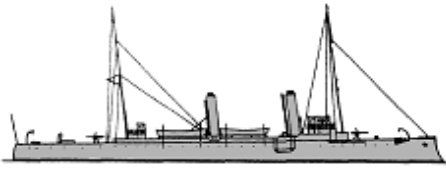
| | | | | | | |
|----|-----------------|-----|-----------------|------|--|--|
| | | | | |  | 7189t, 96.1x17.4x8.2m, 8b,1hr cr, 3700hp, 10kts, 500p; iron- 130belt, 120battery; 8x1- 254/14, 7x1- 203/15, 1x1- 200/35 |
| BB | Vitoria | 1 2 | Vitoria | 1867 |  | 7135t, 96.4ppx17.4x8.1m, 8b,1hr cr, 4500hp, 12kts, 500p; iron- 130belt, 120battery; 4x1- 254/14, 3x1- 203/15, 14x1- 200/12 |
| | Pelayo | 1 3 | Pelayo | 1888 |  | 9950t, 105.1x20.2x7.6m, 16b,2vc, 9473hp, 16kts, 520p; steel- 450belt, 70deck, 400barbettes, 155CT; 2x1- 320/35, 2x1- 280/35, 9x1- 140/36, 5x1- 57/42, 14x1- 37/27, 7-381TT |
| BC | Duque de Tetuán | 1 1 | Duque de Tetuán | 1874 | No picture | 703t, 43.0x9.5x2.2m, 190hp, 6kts, 60p; iron- 100side, 100battery; 1x1- 160/16, 4x1- 121/12 |
| | Puigcerdá | 1 2 | Puigcerdá | 1875 |  | 552t, 39.0x9.0x2.5m, 328hp, 8kts, 59p; iron- 100belt, 100turrets; 1x1- 160/16, 1x2- |



CRUISERS

| | | | | | | | |
|-----|---------------|---|-------------------|------------------------|------|--|---|
| CA | Carlos V | 1 | 1 | Carlos V | 1897 |  | 10100t, 115.8x20.4x7.6m, 12b,2vte, 18500hp, 20kts, 583p; 50belt, 50deck, 250barbettes, 300CT; 2x1- 280/35, 8x1- 140/36, 4x1-57/42, 2x1-42/43, 4x1- 37/27, 6-356TT |
| CL | Isla de Luzón | 1 | 1 | Marqués de la Ensenada | 1894 |  | 1030t, 60.0x9.1x3.8m, 2b,2hte, 2627hp, 15.9kts, 164p; steel- 64deck, 51CT; 6x1-120/35, 4x1-57/40, 3- 356TT |
| CL | Reina Regente | 2 | 3 | Alfonso XIII | 1896 |  | 4725t, 97.1x15.2x6.2m, 4b,2hte, 11500hp, 20.4kts, 440p; steel- 120deck, 75shields; 4x1- 200/35, 6x1- 120/35, 6x1-57/42, 6x1-37/27, 5- 356TT |
| | | | Lepanto | 1899 | | | |
| | Aragón | 2 | 2 | Aragón | 1881 |  | 3289t, 71.9x13.4x7.2m, 4400hp, 14kts, 392p; 6x1- 160/25(1), 4x1- 149/32(2), 2x1- 120/27(2), 2x1- 87/22, 4x1-75/24, 2-356TT |
| | | | Navarra | 1889 | | | |
| CLL | Velasco | 3 | 5 | Infanta Isabel | 1888 |  | 1152t, 67.4x9.8x3.9m, 4b,1hc, 1500hp, 13kts, 173p; 4x1- 120/35, 4x5-37/17, 4x1-25/40, 2- 356TT |
| | | | Isabel II | 1888 | | | |
| | | | Conde de Venadito | 1891 | | | |
| | Alfonso XII | 1 | 6 | Alfonso XII | 1891 |  | 3042t, 84.8x13.2x6.1m, 1hc, 4400hp, 17kts, 370p; 6x1-160/35, 8x1-57/40, 6x5- 47/22, 5-356TT |

TORPEDO SHIPS

| | | | | | | | |
|--|------------|---|---|------------|------|--|--|
| | Destructor | 1 | 1 | Destructor | 1887 | | 348t, 58.7x7.6x2.1m, 4b,2vte, 3784hp, 23kts, 45p; steel- 19belt, 19CT; 1x1-87/27, 4x1- |
|--|------------|---|---|------------|------|--|--|

| | | | | | | | |
|-----|-----------------|---|----------------------|-------------------------------|---|---|---|
| | | | | |  | 57/42, 2x5-37/17, (3+1x2)-356TT | |
| PGT | Temerario | 2 | Temerario | 1891 |  | 630t, 58.0ppx6.7x3.2m, 2b,2vte, 2600hp, 19kts, 91p; steel- 13deck; 2x1-120/35, 4x1-57/42, 1x4-25/42, 2x1-356TT | |
| | | 3 | Nueva España | 1891 | | | |
| | | 4 | Marqués de Molins | 1894 | | | |
| | | 5 | Martín Alonzo Pinzón | 1893 | | | |
| | | 6 | Vicente Yáñez Pinzón | 1894 | | | |
| | Filipinas | 1 | 7 | Filipinas | 1895 |  | 747t, 70.7x8.2x2.4m, 4b,2vte, 4500hp, 20kts, 110p; 2x1- 20/35, 4x1-42/42, (1+3x1)-356TT |
| | María de Molina | 1 | 8 | María de Molina | 1898 |  | 830t, 71.6ppx8.0x2.7m, 4b,2vte, 3500hp, 19.5kts, 91p; 152CT; 2x1-120/35, 4x1-42/42, (1+2x1)-356TT |
| DD | Furor | 1 | 1 | Terror | 1896 |  | 450t, 67.1ppx6.7x1.7m, 4b,2vte, 6000hp, 28kts, 67p; 2x1-75/42, 2x1-57/42, 2x1-37/27, 2x1- 356TT |
| | Audaz | 3 | 2 | Audaz | 1898 |  | 430(2,3)-457(4)t, 69.8x6.9x1.8m, 4b,2vte, 7500hp, 30kts, 67p; 2x1-75/42, 2x1-57/42, 2x1-37/27, 2x1- 356TT |
| | | | 4 | Proserpina | 1898 | | |
| TB | Cástor | 1 | 1 | Cástor | 1878 |  | 23t, 23.2x3.0x0.7m, 1b,1vc, 265hp, 19kts, 14p; 1x5-47/22, 1spar torpedo |
| | Rigel | 1 | 2 | Rigel | 1883 |  | 57t, 32.0x3.7x1.0m, 1b,1vc, 800hp, 19kts, 18p; 1x5-37/17, 2-356TT |
| | Acevedo | 2 | 3, 4 | Acevedo, Julián Ordóñez | 1885 |  | 65t, 36.5x3.8x1.7m, 1b,1vc, 660hp, 20.5kts, 17p; 2x5-25/42, 2-356TT |
| | Retamosa | 1 | 5 | Retamosa | 1886 |  | 70t, 36.6x3.8x1.6m, 1b,1vte, 700hp, 20kts, 17p; 2x5-25/42, 2-356TT |
| | Orión | 1 | 6 | Orión | 1886 |  | 88t, 38.0x4.8x2.0m, 1b,1vc, 1000hp, 21kts, 18p; 2x5-25/42, 2-356TT |
| | Barceló | 2 | 7, 8 | Barceló, Bustamante | 1886- 1887 |  | 65t, 38.0x3.1x2.2m, 1b,1vc, 800hp, 20kts, 17p; 2x1- 47/40(8), 2x5-25/42(7), 2-356TT |
| | Habana | 1 | 9 | Habana | 1887 |  | 67t, 38.9x3.8x1.6m, 1b,1vc, 730hp, 24.5kts, 17p; 1x5-25/42, 2-356TT |
| | | | 10 | Azor | 1887 | | 108t, 41.1x4.2x2.1m, 1b,1vc, |

| | | | | | | |
|----------|---|-------|----------|------|---|--|
| Azor | 2 | | | |  | 1300hp, 24kts, 23p; 3x1-42/42, 2-356TT |
| | | 11 | Halcón | 1887 | | |
| Ariete | 2 | 12 | Ariete | 1887 |  | 120t, 45.0x4.5x1.5m, 2b,2vc, 1300hp, 26.2kts, 18p; 2x1-42/42, 2x1-25/42, 2-356TT |
| | | 13 | Rayo | 1887 | | |
| Ejército | 1 | 14 | Ejército | 1888 | No picture | 60t, 34.0x4.0x1.0m, 1b,1vc, 600hp, 18kts, 20p; 1x5-37/17, 2-356TT |
| Vedette | 3 | 15-17 | No1-3 | 1892 | No picture | 18.3x2.8m, 1b,1vc, 18.3kts, 13p |

SUBMARINES

| | | | | | | | |
|----|-------|---|---|-------|------|------------|--|
| SS | Peral | 1 | 1 | Peral | 1890 | No picture | /87t, 21.3x2.6m, 2em, 60hp, /10kts, 6p, 50m; 1-356TT |
|----|-------|---|---|-------|------|------------|--|

OTHER FIGHTING SHIPS



| | | | | | | | |
|---------------|----------------|----|-----------------------|-------------------------|------------|--|--|
| PG | Somorrostro | 3 | 1-3 | Bidasoa, Toledo, Segura | 1875 | No picture | 86t, 24.0x4.9x1.9m, 1b,1hse, 80hp, 9kts, 22p; 1x2-121/14 |
| | Pilar | 1 | 4 | Pilar | 1881 | No picture | 255t, 35.2x6.6x2.5m, 1b,1vc, 260hp, 8.5kts, 49p; 1x1-120/25, 1x1-87/22 |
| | General Concha | 2 | 5 | General Concha | 1885 | No picture | 620t, 50.4x7.9x3.4m, 2b,2vc, 600hp, 11kts, 98p; 3x1-120/25, 2x4-25/42 |
| | | | 6 | Magallanes | 1887 | | |
| | Mac-Mahón | 1 | 7 | Mac-Mahón | 1888 | No picture | 115t, 27.6x4.9x1.8m, 2b,2vte, 150hp, 9kts, 15p; 2x1-42/42, 1x5-37/17 |
| | Hernan Cortés | 2 | 8 | Hernan Cortés | 1895 | No picture | 295t, 47.4x6.6x1.9m, 1b,1vte, 352hp, 13kts, 53p; 2x1-75/42, 2x1-57/42 |
| 9 | | | Vasco Núñez de Balboa | 1895 | | | |
| Ponce de Leon | 1 | 10 | Ponce de Leon | 1896 | No picture | 200t, 41.4x5.8x1.8m, 2b,2vte, 230hp, 12kts, 38p; 2x1-57/42 | |
| PR | Tarifa | 1 | 1 | Tarifa | 1879 | No picture | 85t, 35.2x6.7x2.0m, 80hp, 8kts; 1x1-87/22 |
| | Cóndor | 3 | 2-4 | Cóndor, Cuervo, Águila | 1888-1892 | No picture | 71t, 24.5x3.9x1.8m, 300hp, 13kts, 27p; 1x1-87/27 |
| | Perla | 1 | 5 | Perla | 1889 | No picture | 42t, 19.0x3.6x1.8m, 110hp, 7kts, 26p; 1x2-25/42 |
| | Alerta | 1 | 6 | Alerta | 1895 | No picture | 43t, 21.3x2.7x1.3m, 200hp, 10.5kts, 13p; 1x1-42/42, 1x1-37/27 |

© Ivan Gogin, 2014

[home](#)[World navies yesterday](#)[1900](#)

Sweden 01 January 1900

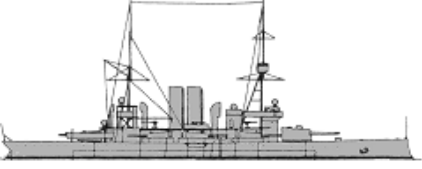
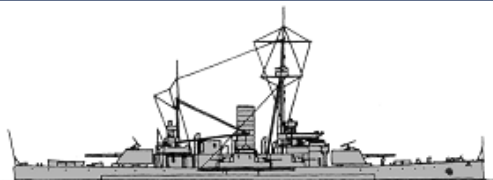



BATTLESHIPS







| | | | | | | | |
|-----|---------------|---|---|---------------|------|---|--|
| BC | Svea | 3 | 1 | Svea | 1886 |  | 3273(1)-3300(2,3)t, 75.7(1)-78.8(2)-79.5(3)x14.8(1)-14.6(2,3)-5.1m, 6b,2vc, 3640(1)-4700(2,3)hp, 14.7(1)-16(2,3)kts, 252p; compound(1)- steel(2,3)- 297(1)-293(2,3)belt, 49deck, 297(1)-293(2,3)turret; 1x2-254/31, 4x1- 152/30(2,3), 4x1-120/43(1), 2x1-57/48(1), 5x1- 57/48(2), 5x1-57/46(3), 1x2-37/34(1), 4x1- 25/57(2,3), 4x4-25/32(1), 6x4-25/32(2), 4x4- 25/32(3), 1x1-12/75(1), 2-450TT(3), 1-381TT(1), 3-381TT(2) |
| | | | 2 | Göta | 1891 | | |
| | | | 3 | Thule | 1893 | | |
| | Oden | 3 | 4 | Oden | 1897 |  | 3715(4)-3720(5,6)t, 86.3x14.8x5.3m, 6b,2vte, 5350hp, 16.5kts, 254p; steel(4)-Harvey(5,6)- 243(4)-240(5,6)belt, 49deck, 200(4)-190(5,6)turrets, 247(4)-190(5,6)CT; 2x1-254/41, 4x1-120/43(4), 6x1-120/43(5,6), 10x1-57/52(5,6), 4x1-57/26(4), 6x1-47/49(4), 2x1-25/32(4), 2x2-25/32(5,6), 1-450TT |
| | | | 5 | Thor | 1899 | | |
| | | | 6 | Njord | 1899 | | |
| MON | John Ericsson | 3 | 1 | John Ericsson | 1865 |  | 1476t, 60.8x13.8x3.7m, 2b,1vde, 380hp, 7kts, 80p; iron- 125(1)-118(2,3)belt, 48(1)-25(2,3)deck, 270(1)-261(2,3)turret, 250(1)-237(2,3)CT; 1x2-274/16(2,3), 2x1- 152/30(1), 2x1-57/46(1), 2x5-12/75(2,3) |
| | | | 2 | Thordön | 1866 | | |
| | | | 3 | Tirfing | 1867 | | |
| | Loke | 1 | 4 | Loke | 1871 |  | 1574t, 64.0x14.0x3.6m, 2b,1vde, 430hp, 8.5kts, 80p; iron- 125belt, 25deck, 447turret, 237CT; 1x2-240/16 |

CRUISERS



| | | | | | | | |
|----|--------|---|---|--------|------|------------|--|
| CL | Balder | 1 | 1 | Balder | 1871 | No picture | 1886t, 61.8x11.1x5.6m, 1hrccr, 1380hp, 12kts, 218p; 1x1-152/30, 8x1-122/23, 1x1-65/16, 2x1-37/34 |
| | Saga | 1 | 2 | Saga | 1878 | No picture | 1617t, 61.0x10.2x5.6m, 1, 900hp, 11kts, 188p; 1x1-152/25, 8x1-122/20, 1x1-65/16 |
| | Freja | 1 | 3 | Freja | 1886 | No picture | 2000t, 66.0ppx12.0x5.7m, 1, 1750hp, 12kts, 284p; 4x1-152/25, 8x1-122/23, 2x1-65/16, 4x1-37/34 |

TORPEDO SHIPS

| | | | | | | | |
|-----------|--------|---|-------|--------------------------|------|---|---|
| PGT | Örnen | 3 | 1 | Örnen | 1897 |  | 844(1)-846(2)-835(3)t, 67.7x8.2x3.1m, 8b,2vte, 4000hp, 20kts, 113p; 2x1-120/43, 4x1-57/50, 1- 381TT |
| | | | 2 | Claes Horn | 1898 | | |
| | | | 3 | Jacob Bagge | 1898 | | |
| TB 1cl | Hugin | 1 | 1 | Hugin | 1884 |  | 64t, 34.5x3.8x2.0m, 1b,1vc, 620hp, 18.5kts; 1x1-25/32, 2-381TT |
| | Munin | 3 | 2-4 | Munin, Freke, Gere | 1887 |  | 66t, 34.8x3.8x2.0m, 1b,1vc, 620hp, 18.5kts; 1x1-25/57, 2-381TT |
| | Gondul | 2 | 5,6 | Gondul, Gudur | 1894 |  | 86t, 38.6x4.3x2.1m, 1b,1vc, 850hp, 19.5kts, 18p; 2x1-25/57, (1+1x1)-381TT |
| | Komet | 4 | 7 | Komet | 1896 | | 120t, 39.8x4.8x2.5m, 1b,1vc, 1300hp, 23kts, 18p; |
| 8 | | | Blixt | 1898 | | | |

| | | | | | | | |
|-------|-------|----|---------|---------------|--|---|--|
| | | | | |  | | |
| | | 9 | Meteor | 1899 | | 2x1-37/37, (1+1x1)-381TT | |
| | | 10 | Stjerna | 1899 | | | |
| TB2cl | Rolf | 1 | 1 | Blink | 1882 |  | 38t, 27.9xxm, 1b,1vc, 350hp, 16kts; 1x1-25/32, 2-356TT |
| | Blixt | 2 | 2, 3 | Blixt, Galdr | 1883-1885 |  | 43t, 30.5xxm, 1b,1vc, 420hp, 19kts; 1x1-25/32, 2-356TT |
| | Narf | 2 | 4, 5 | Narf, Nörve | 1886 |  | 45t, 30.5x3.6x1.9m, 1b,1vc, 440hp, 19.5kts; 1x1-25/32, 2-356TT |
| | Bygve | 2 | 6, 7 | Bygve, Bylgia | 1887 |  | 57t, 31.5x3.6x1.9m, 1b,1vc, 460hp, 18.5kts; 1x1-25/58, 2-381TT |
| | Agne | 2 | 8, 9 | Agne, Agda | 1891-1892 |  | 55t, 30.6x3.6x1.9m, 1b,1vc, 460hp, 18.9kts; 1x1-25/58, (1+1x1)-381TT |

OTHER FIGHTING SHIPS

| | | | | | | | |
|-----------|--------|----|-----------|----------|------------|---|--|
| MONL | Sköld | 2 | 1 | Sköld | 1871 |  | 262t, 32.7x6.9x2.2m, 1b,1hc, 17hp, 3.7kts, 42p; iron- 25side, 229turret; 1x1-240/16, 2x1-12/75 |
| | | | 2 | Fenris | 1872 | | |
| | Gerda | 2 | 3 | Gerda | 1872 |  | 459t, 39.7x8.0x2.5m, 2b,2hc, 133hp, 7.6kts, 42p; iron- 76belt, 418turret; 1x1-240/18, 2x1-25/32 |
| | | | 4 | Hildur | 1872 | | |
| | Ulf | 5 | 5 | Ulf | 1873 |  | 460t, 39.8x8.0x2.5m, 2b,2hc, 155hp, 8kts, 42p; iron- 76belt, 418turret; 1x1-240/18, 2x1-25/32 |
| | | | 6 | Björn | 1874 | | |
| | | | 7 | Berserk | 1874 | | |
| | | | 8 | Sölve | 1875 | | |
| | | | 9 | Folke | 1875 | | |
| PG | Astrid | 2 | 1 | Sigrid | 1862 | No picture | 204t, 32.0x6.3x2.2m, 1, 130hp, 9kts, 39p; iron- 20deck; 2x1-204/12 |
| | | | 2 | Alfhild | 1863 | | |
| | Blenda | 2 | 3 | Blenda | 1875 | No picture | 550t, 51.1x8.1x3.0m, 2b,2hc, 590hp, 11.5kts, 71p; 51CT(4); 1x1-274/17(3), 1x1-152/25(4), 1x1-122/23(3), 2x1-57/50(4) |
| | | | 4 | Disa | 1877 | | |
| | Urd | 6 | 5 | Urd | 1877 | No picture | 550t, 53.6x8.1x2.8m, 2b,2hc, 780hp, 72p; 51CT(5,7); 1x1-274/17(6,8-10), 1x1-152/30(5,7), 1x1-122/23(6,8-10), 1x1-120/43(5,7), 2x1-57/50(5,7,10), 2x1-25/32(6,8-10) |
| | | | 6 | Verdande | 1880 | | |
| | | | 7 | Skagul | 1878 | | |
| | | | 8 | Skuld | 1881 | | |
| | | | 9 | Skäggard | 1879 | | |
| | | | 10 | Rota | 1878 | | |
| Edda | 1 | 11 | Edda | 1885 | No picture | 640t, 55.8x8.3x3.1m, 2b,2vc, 960hp, 13.5kts, 76p; 1x1-274/23, 1x1-152/25, 2x1-25/32 | |
| Svenskund | 1 | 12 | Svenskund | 1891 | No picture | 280t, 38.5x7.9x3.0m, 440hp, 12.5kts; 2x1-57/50, mines | |

MINE WARFARE SHIPS

| | | | | | | | |
|----|--------------------|---|---|--------------------|------|------------|---------------------|
| ML | Ångkranpramen N:r3 | 1 | 1 | Ångkranpramen N:r3 | 1879 | No picture | 190t, 6.5kts; mines |
|----|--------------------|---|---|--------------------|------|------------|---------------------|

[home](#)

[World navies yesterday](#)

[1900](#)

United Kingdom 01 January 1900

BATTLESHIPS

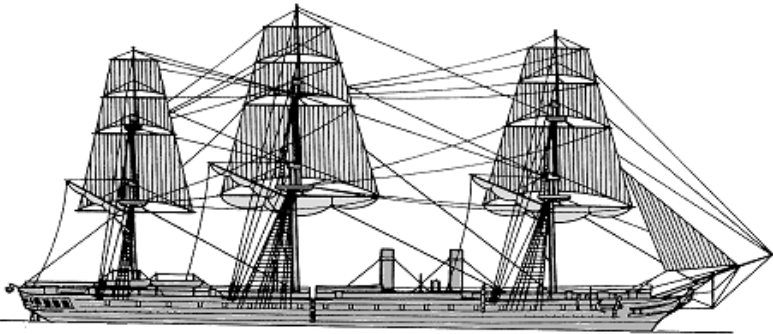
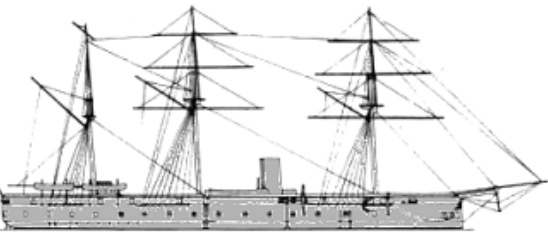
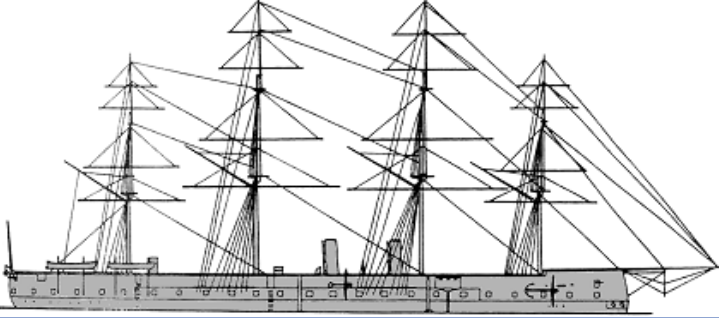
| | | | | | |
|----------|-----|----------|------|--|---|
| Warrior | 1 1 | Warrior | 1861 |  | 9137t, 128.0x17.8x7.9m, 10b,1hset, 5267hp, 14.1kts, 635p; iron: 114belt; 4x1-203/15MLR, 28x1-178/16MLR, 4x1-95/21 |
| Hector | 1 2 | Hector | 1864 |  | 6710t, 92.0x17.1x7.6m, 6b,1hrccr, 3260hp, 12.6kts, 530p; iron: 114belt, 114battery; 2x1-203/15MLR, 16x1-178/16MLR |
| Achilles | 1 3 | Achilles | 1864 |  | 9820t, 115.8ppx17.8x8.3m, 10b,1hset, 5720hp, 14.3kts, 705p; iron: 114belt, 114battery; 14x1-229/14MLR, 2x1-152/26, 8x1- 47/40, 16x1-11.4, 6-356TC |
| | | | | | 7551t, 91.4x17.1x7.5m, 8b,1hset, 6521hp, 14.2kts, 650p; |

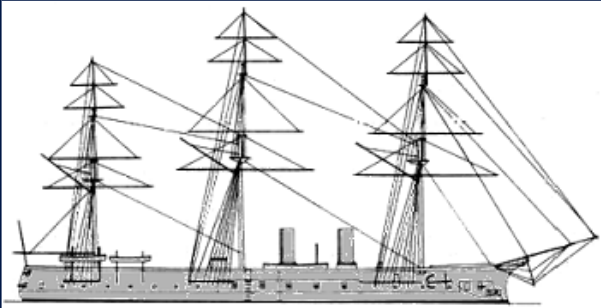
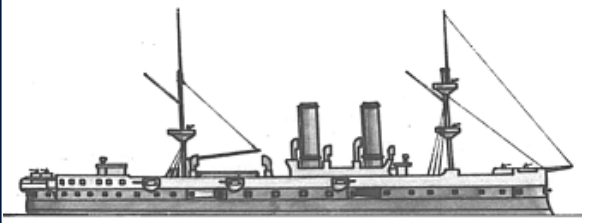
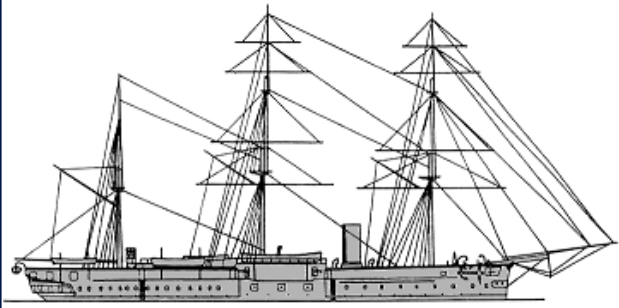
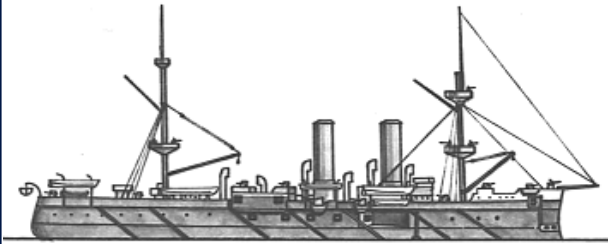
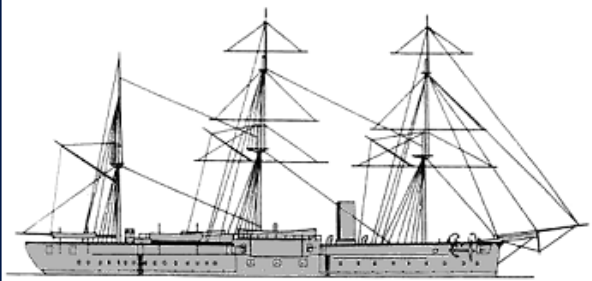
| | | | | | | |
|-------------|---|----|-------------|------|--|---|
| Bellerophon | 1 | 4 | Bellerophon | 1866 |  | iron: 152belt, 152battery, 203CT; 10x1-203/26, 4x1-152/26, 6x1-102/25, 4x1-57/40, 12x1-11.4, 2-406TC |
| Hercules | 1 | 5 | Hercules | 1868 |  | 8830t, 99.1ppx18.0x7.7m, 8b,1ite, 8530hp, 15.9kts, 638p; iron: 229belt, 203battery; 8x1-254/15MLR, 2x1-229/14MLR, 3x1-178/16MLR, 2x1-152/40, 8x1-148/11, 6x1-120/40, 9x1-57/40, 13x1-47/40, 4-356TC |
| Audacious | 3 | 6 | Audacious | 1870 |  | 6010t, 85.3ppx16.5x6.9m, 6b,2hrccr, 4020-4830hp, 12.6-14.1kts, 450p; iron: 203belt, 152battery; 10x1-229/14MLR, 4x1-127/25(8), 8x1-102/27(6), 6x1-102/27(7), 6x1-95/21, 4x1-57/40(6), 6x1-47/40(6), 4-356TC |
| | | 7 | Invincible | 1870 | | |
| | | 8 | Iron Duke | 1871 | | |
| Sultan | 1 | 9 | Sultan | 1871 |  | 9540t, 99.1ppx18.0x8.1m, 8b,1vte, 8244hp, 15.3kts, 633p; iron: 229belt, 229battery; 8x1-254/15MLR, 4x1-229/14MLR, 4x1-120/40, 7x1-95/21, 4x1-57/40, 4-356TC, 2 TBs |
| Swiftsure | 2 | 10 | Swiftsure | 1872 |  | 6640-6910t, 85.3x16.8x7.6m, 6b,1hrccr, 4890-4910hp, 13.7-14.1kts, 450p; iron: 203belt, 152battery; 10x1-229/14MLR, 4x1-127/25(11), 8x1-102/27(10), 6x1-95/21, 8x1-57/40, 8x1-47/40, 4-356TC |
| | | 11 | Triumph | 1873 | | |
| | | 12 | Devastation | 1873 | | |

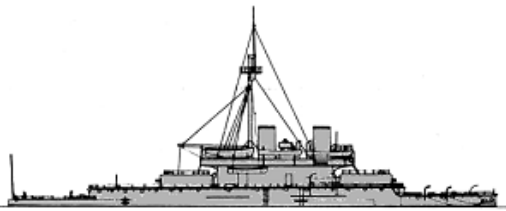
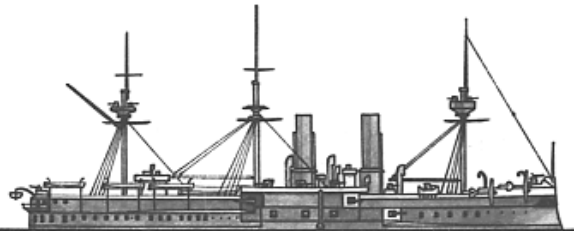
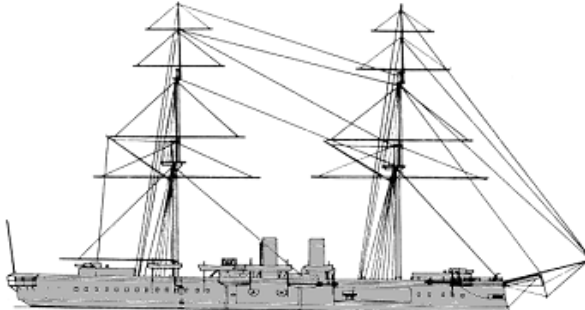
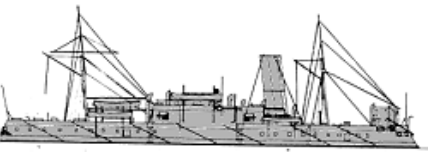
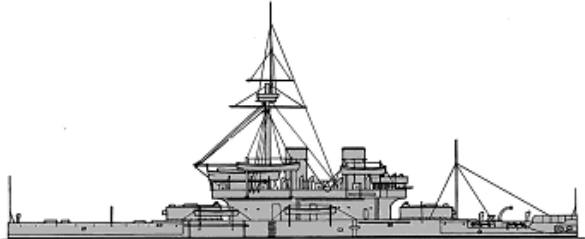
| | | | | | | |
|-------------|---|----|-------------|------|--|---|
| Devastation | 2 | 13 | Thunderer | 1877 |  | 9387-9390t, 93.6x19.0x8.0m, 8b,2vte, 7000hp, 14kts, 358p; iron: 305belt, 76deck, 356turrets, 229CT; 2x2-254/32, 6x1-57/40, 8x1-47/40, 8x1-25/60, 2-356TT |
| Alexandra | 1 | 14 | Alexandra | 1877 |  | 9492t, 104.9x19.5x8.0m, 12b,2vic, 8498hp, 15.1kts, 674p; iron: 305belt, 38deck, 305battery, 305CT; 8x1-254/15MLR, 4x1-234/32, 6x1-120/40, 6x1-57/40, 12x1-47/40, 4-356TC |
| Temeraire | 1 | 15 | Temeraire | 1877 |  | 8540t, 86.9ppx18.9x8.2m, 12b,2vic, 7697hp, 14.7kts, 580p; iron: 279belt, 38deck, 254barbettes; 4x1-279/12MLR, 4x1-254/15MLR, 6x1-102/27, 4x1-57/40, 10x1-47/40, 2-356TC |
| Belleisle | 2 | 16 | Belleisle | 1878 |  | 4870t, 74.7ppx15.9x6.4m, 4b,2hdase, 4040hp, 13kts, 250p; iron: 305belt, 76deck, 267battery, 229CT; 4x1-305/14MLR, 4x1-95/21, 6x1-47/40, 2-356TC |
| | | 17 | Orion | 1882 | | |
| Dreadnought | 1 | 18 | Dreadnought | 1879 |  | 10886t, 104.6x19.5x8.1m, 12b,2vce, 8206hp, 14.5kts, 369p; iron: 356belt, 76deck, 356turrets, 356CT; 2x2-318/16MLR, 6x1-57/40, 10x1-47/40, 2-356TT |
| Superb | 1 | 19 | Superb | 1880 | | 9710t, 101.3ppx18.0x7.8m, 5b,2hte, 8500hp, 14.5kts, 654p; iron: 305belt, 38deck, 305battery, 203CT; 12x1-254/15MLR, 10x1-152/40, 6x1-57/40, 10x1-47/40, 4-356TC |

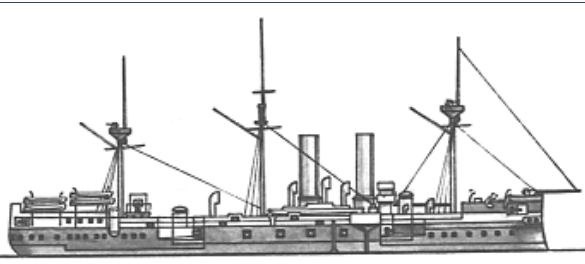
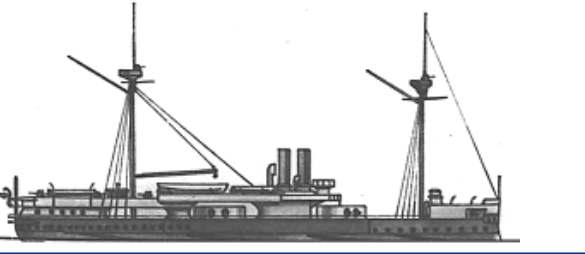
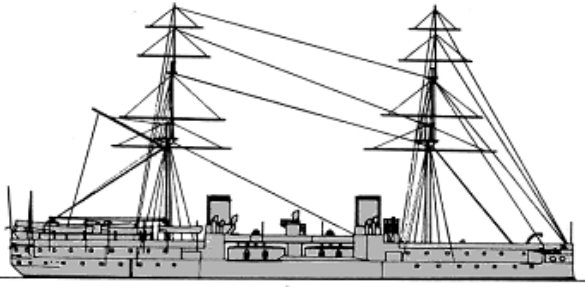
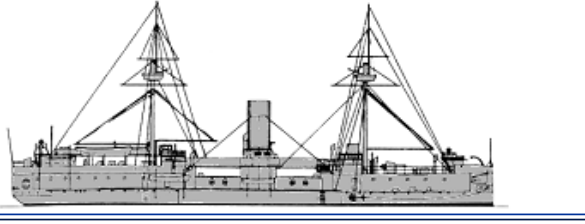
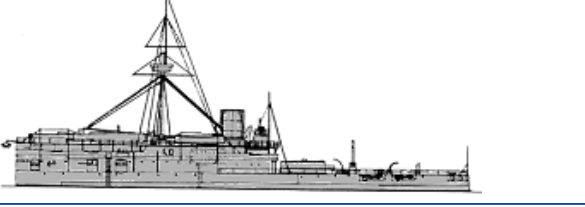

BB

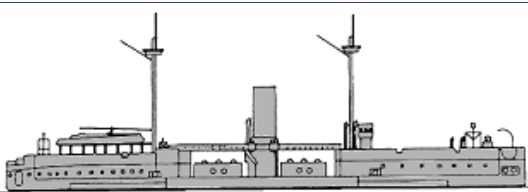
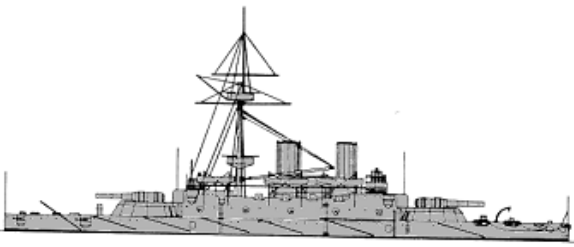
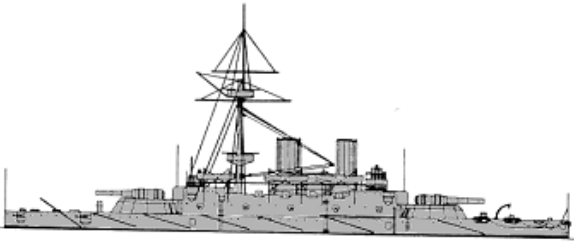
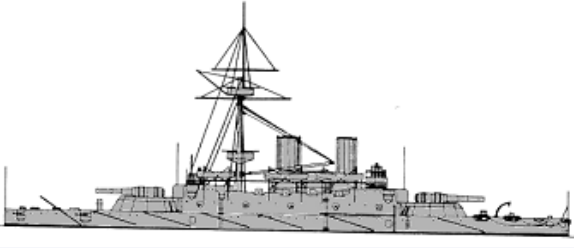
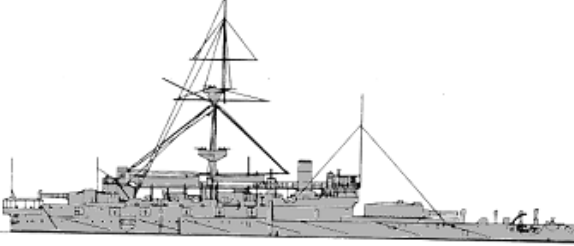

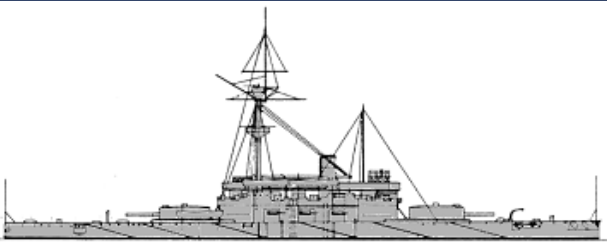
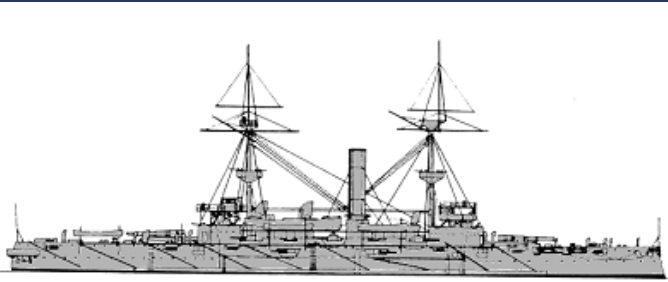
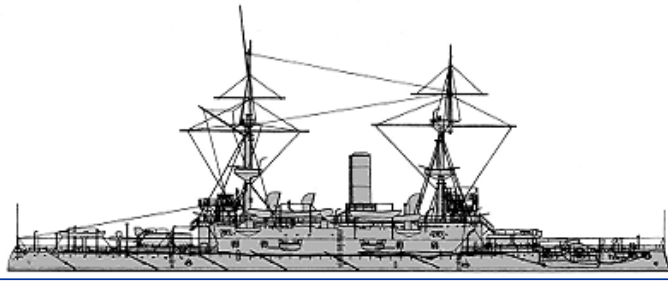
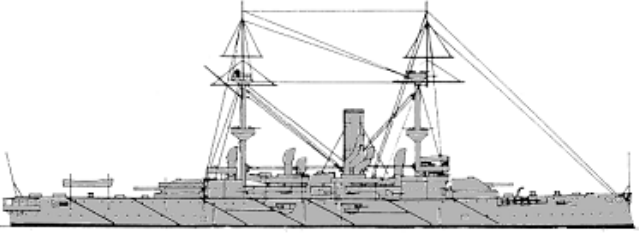
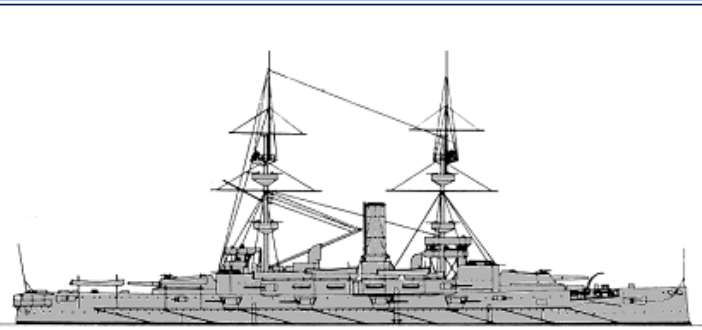

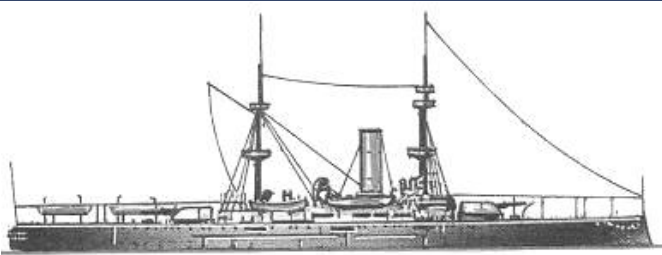
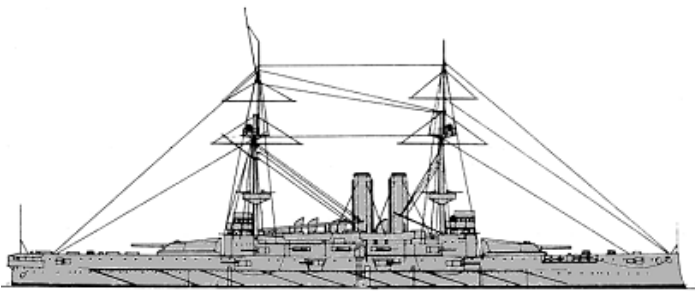
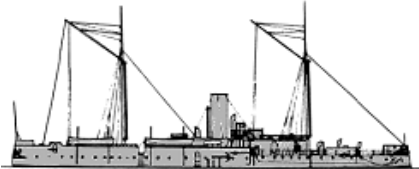
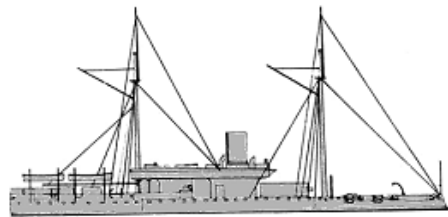
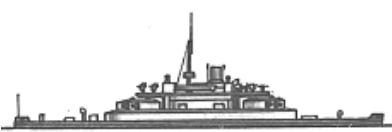
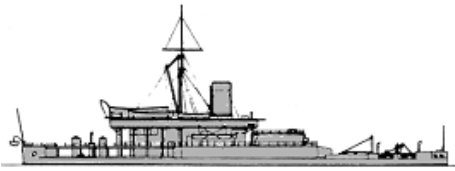
| | | | | | | |
|------------|---|----|------------|---|--|--|
| | | | |  | | |
| Neptune | 1 | 20 | Neptune | 1881 |  | 9130t, 91.4ppx19.2x7.6m, 8b,1hset, 7993hp, 14.2kts, 541p; iron: 305belt, 76deck, 330turrets, 203CT; 2x2-305/12MLR, 2x1-229/14MLR, 6x1-95/21, 6x1-57/40, 8x1-47/40, 2-356TC |
| Inflexible | 1 | 21 | Inflexible | 1881 |  | 11880t, 104.9x22.9x7.8m, 12b,2ice, 8488hp, 14.7kts, 440p; iron: 610belt, 76deck, 432turrets(compound), 305CT; 2x2-406/18MLR, 8x1-120/40, 4x1-57/40, 2x1-47/40, (2+2)-356TT/TC |
| Agamemnon | 2 | 22 | Agamemnon | 1883 |  | 8510t, 91.7x20.1x7.2m, 10b,2ice, 6000hp, 13kts, 345p; iron: 457belt, 76deck, 406turrets(compound), 305CT; 2x2-318/16MLR, 2x1-152/26, 6x1-57/43, 8x1-47/40, 2-356TC |
| | | 23 | Ajax | 1883 | | |
| Conqueror | 2 | 24 | Comqueror | 1886 |  | 6200-6440t, 87.8x17.7x7.2m, 8b,2ice, 6000hp, 15.5kts, 330p; compound: 305belt, 64deck, 356turret, 305CT; 1x2-305/25, 4x1-152/26, 7x1-57/40, 5x1-47/40, 6-356TC |
| | | 25 | Hero | 1888 | | |
| Colossus | 2 | 26 | Edinburgh | 1887 | | 9420t, 99.1ppx20.7x7.9m, 10b,2ice, 6808(26)-7488(27)hp, 16(26)-16.5(27)kts, 396p; compound: 457belt, 76deck, 406turrets, 356CT; 2x2-305/25, 5x1-152/27, 4x1-57/40, 10x1-47/40, 2-356TT |
| | | 27 | Colossus | 1885 | | |

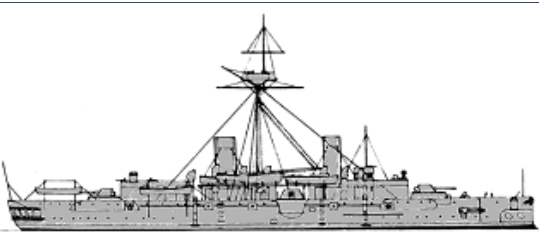

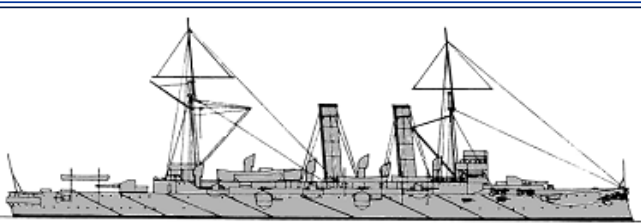
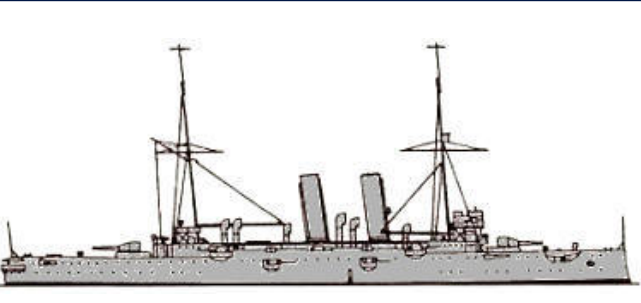
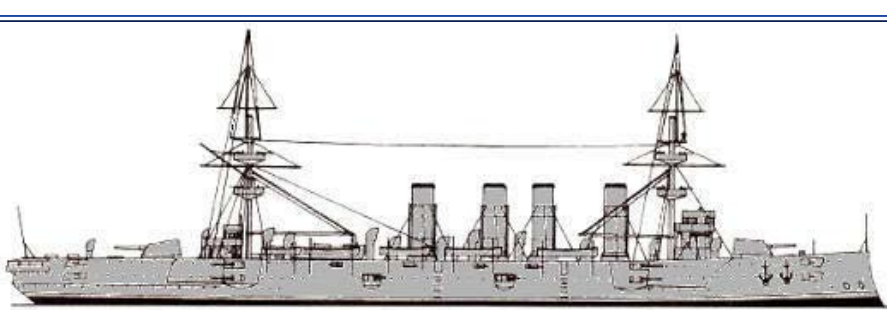
| | | | | | | |
|-------------|---|----|-------------|---|--|--|
| | | | |  | | |
| Collingwood | 1 | 28 | Collingwood | 1887 |  | 9500t, 99.1ppx20.7x8.0m, 12b,2ice, 9600hp, 16.8kts, 498pp; compound: 457belt, 76deck, 229barbettes, 305CT: 2x2-305/25, 6x1-152/27, 12x1-57/40, 8x1-47/40, 4-356TT |
| Rodney | 4 | 29 | Rodney | 1888 |  | 10300(29,30)-10600(31,32)t, 99.1pp(29,30)-100.6pp(31,32)x20.7(29,30)-20.9(31,32)x8.5m, 12b,3ice, 11500hp, 17(29,30)-17.4(31,32)kts, 530p; compound: 457belt, 76decks, 292(29,30)-356(31,32)barbettes, 305CT: 2x2-343/30, 6x1-152/27, 12x1-57/40, 10x1-47/40, 5-356TT |
| | | 30 | Howe | 1889 | | |
| | | 31 | Camperdown | 1889 | | |
| | | 32 | Anson | 1889 | | |
| Benbow | 1 | 33 | Benbow | 1888 |  | 10600t, 100.6ppx20.9x8.5m, 12b,2ice, 10860hp, 17.5kts, 523p; compound: 457belt, 76deck, 356barbettes, 305CT; 2x1-413/30, 10x1-152/27, 12x1-157/40, 7x1-47/40, 5-356TT |
| Victoria | 1 | 34 | Sans Pareil | 1891 |  | 10470t, 110.6x21.3x8.2m, 8b,2vte, 14482hp, 17.7kts, 430p; compound: 457belt, 76deck, 432turret, 356CT; 1x2-413/30, 1x1-254/32, 12x1-152/27, 12x1-57/40, 9x1-47/40, (4+2)-356TT/TC |
| Trafalgar | 2 | 35 | Trafalgar | 1890 | | 12590t, 105.2ppx22.3x8.7m, 6b,2vte, 12000hp, 16.7kts, 577p; compound: 508belt, 76deck, 457turret, 356CT; 2x2-343/30, 6x1-152/40, 8x1-57/40, 9x1-47/40, 4-356TT |
| | | 36 | Nile | 1891 | | |

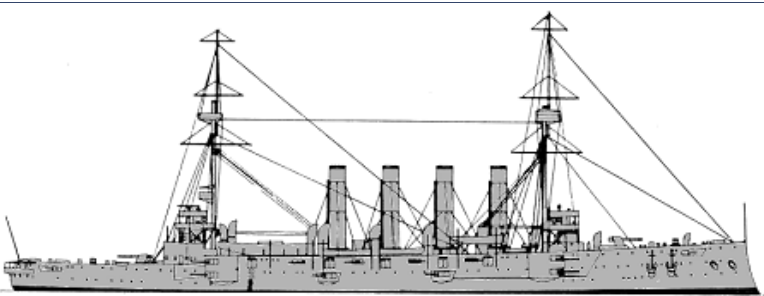
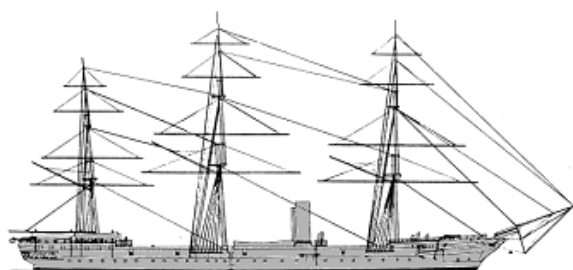
| | | | | | | |
|-----------------|-------------|------|------------------|---|--|---|
| | | | |  | | |
| Royal Sovereign | 7 | 37 | Royal Sovereign | 1892 |  | 15580t, 125.0x22.9x8.4m, 8b,2vte, 11000hp, 16.5kts, 712p; compound: 457belt, 76deck, 432barbettes, 356CT; 2x2-343/30, 10x1-152/40, 16x1-57/40, 12x1-47/40, 7-450TT |
| | | 38 | Empress of India | 1893 | | |
| | | 39 | Repulse | 1894 | | |
| | | 40 | Ramillies | 1893 | | |
| | | 41 | Resolution | 1893 | | |
| | | 42 | Revenge | 1894 | | |
| | | 43 | Royal Oak | 1894 | | |
| Hood | 1 | 44 | Hood | 1893 |  | 15590t, 125.0x22.9x8.3m, 8b,2vte, 11000hp, 16.7kts, 690p; compound: 457belt, 76deck, 432turrets, 356CT; 2x2-343/30, 10x1-152/40, 10x1-57/40, 12x1-47/40, 5-450TT |
| Centurion | 2 | 45 | Centurion | 1894 |  | 10500t, 109.7ppx21.3x7.8m, 8b,2vte, 13000hp, 18.5kts, 620p; compound: 305belt, 64(NS)deck, 152(Harvey) gun houses, 305CT; 2x2-254/32, 10x1-120/40, 8x1-57/40, 12x1-47/40, 7-450TT |
| | | 46 | Barfleur | 1894 | | |
| Majestic | 9 | 47 | Magnificent | 1895 |  | 15730-16060T, 128.3x22.9x8.2m, 8b,2vte, 12000hp, 17kts, 672p; Harvey: 229belt, 102deck, 254gunhouses, 356CT; 2x2-305/35, 12x1-152/40, 16x1-76/40, 12x1-47/40, 5-450TT |
| | | 48 | Majestic | 1895 | | |
| | | 49 | Prince George | 1896 | | |
| | | 50 | Victorious | 1896 | | |
| | | 51 | Jupiter | 1897 | | |
| | | 52 | Mars | 1897 | | |
| | | 53 | Hannibal | 1898 | | |
| | | 54 | Caesar | 1898 | | |
| 55 | Illustrious | 1898 | | | | |

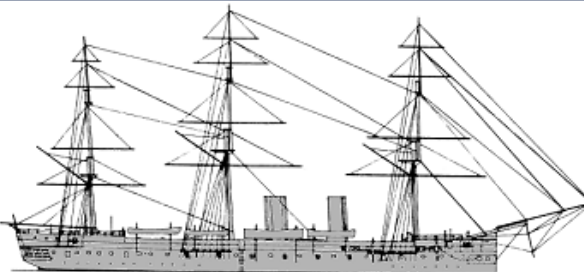
| | | | | | | | |
|-----|----------|---|----|-----------------------------|----------------------|--|---|
| | Renown | 1 | 56 | Renown | 1897 |  | 12350t, 124.4x22.0x8.2m, 8b,2vte, 12000hp, 18kts, 674p; Harvey: 203belt, 76deck, 152gunhouses, 229CT; 2x2-254/32, 10x1-152/40, 12x1-76/40, 12x1-47/40, 5-450TT |
| | Canopus | 1 | 57 | Canopus | 1899 |  | 14300t, 128.5x22.6x8.0m, 20b,2vte, 13500hp, 18kts, 682p; Harvey: 152(Krupp)belt, 76deck, 203gunhouses, 305CT; 2x2-305/35, 12x1-152/40, 10x1-76/40, 6x1-47/40, 4-450TT |
| BC | Hotspur | 1 | 1 | Hotspur | 1871 |  | 4331t, 71.6ppx15.2x6.1m, 2hse, 3497hp, 12.7kts, 209p; iron: 279belt, 70deck, 216(compound)turret, 254CT; 1x2-305/12MLR, 2x1-152/26, 2-356TT, 1torpedo boat |
| | Rupert | 1 | 2 | Rupert | 1874 |  | 5440t, 80.5ppx16.2x6.9m, 2hse, 4630hp, 13.6kts, 217p; iron: 279belt, 76deck, 356turret, 305CT; 1x2-234/32, 2x1-152/26, 4x1-57/40, 6x1-47/40, 8x1-11.4, 4-356TT |
| MON | Cerberus | 1 | 1 | Magdala | 1870 |  | |
| | Glatton | 1 | 2 | Glatton | 1872 |  | 4912t, 74.7ppx16.5x5.8m, 2hrce, 2870hp, 12.1kts, 185p; iron: 305belt, 76deck, 356turret, 229CT; 1x2-305/12MLR, 3x1-57/40, 4x1-11.4, 2-356TC |
| | Cyclops | 4 | 5 | Cyclops Hecate Gorgon | 1877 1877 1874 | | 3560t, 68.6ppx13.7x5.0m, 2hice(5,8)-2hidase(6,7), 1470-1755hp, 10.9-11.2kts, 150p; iron: 203belt, 38deck, 254turrets, 229CT; 2x2-254/15MLR, 4x1-47/40, 5x1-11.4 |

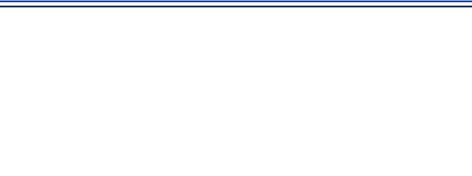
| | | | | | | |
|----------|---------|------|--------------|------|--|---|
| | | | | |  | |
| CA | Orlando | 6 | Orlando | 1888 |  | 5600t, 91.4ppx17.1x6.9m, 4b,2vte, 8500hp, 18kts, 484p; compound: 254belt, 76deck, 305CT; 2x1-234/32, 10x1-152/27, 6x1-57/40, 10x1-47/40, 6-450TT |
| | | 7 | Australia | 1888 | | |
| | | 8 | Undaunted | 1889 | | |
| | | 9 | Narcissus | 1889 | | |
| | | 10 | Galatea | 1889 | | |
| | | 11 | Immortalité | 1889 | | |
| | | 12 | Aurora | 1889 | | |
| Blake | 2 | 13 | Blake | 1892 |  | 9150t, 121.8x19.8x7.3m, 6b,2vte, 20000hp, 21.4kts, 570p; compound: 152deck, 114shields, 305CT; 2x1-234/32, 10x1-152/40, 16x1-47/40, 4-356TT |
| | | 14 | Blenheim | 1894 | | |
| Edgar | 9 | 15 | Edgar | 1893 |  | 7350(15,17-19,23)-7700(16,20-22)t, 118.1x18.3x7.2m, 5b,2vite, 12000hp, 20kts, 544p; steel: 127deck, 152casemates, 305CT; 2x1-234/32(15,17-19,21-23), 1x1-234/32(16,20), 10x1-152/40(15,17-19,21-23), 12x1-152/40(16,20), 12x1-57/40, 5x1-47/40, 4-450TT |
| | | 16 | Royal Arthur | 1893 | | |
| | | 17 | Hawke | 1893 | | |
| | | 18 | Endymion | 1894 | | |
| | | 19 | Grafton | 1894 | | |
| | | 20 | Crescent | 1894 | | |
| | | 21 | Gibraltar | 1894 | | |
| | | 22 | St. George | 1894 | | |
| 23 | Theseus | 1896 | | | | |
| Powerful | 2 | 24 | Terrible | 1898 |  | 14200t, 164.0x21.6x7.3m, 48b,2vte, 25000hp, 22kts, 894p; Harvey: 152deck, 152turrets, 305CT; 2x1-234/41, 12x1-152/40, 16x1-76/40, 12x1-47/40, 4-450TT |
| | | 25 | Powerful | 1897 | | |
| | | 26 | Diadem | 1898 | | |
| | | 27 | Niobe | 1898 | | |
| | | 28 | Europa | 1899 | | |

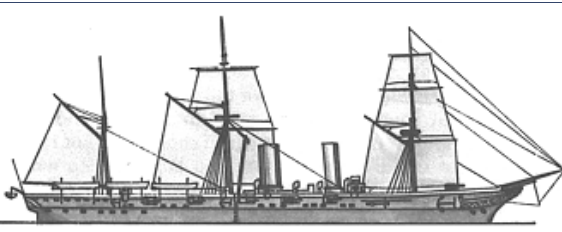
| | | | | | | |
|-----------|---|----|-----------|------|--|--|
| Diadem | 4 | | | |  | 11000t, 141.0x21.0x7.8m, 30b,2vte, 16500hp, 20.2kts, 677p; Harvey: 102deck, 114casemates, 305CT; 16x1-152/40, 14x1-76/40, 3x1-47/40, 3-450TT |
| | | 29 | Andromeda | 1899 | | |
| Volage | 2 | 1 | Volage | 1870 |  | 3078t, 82.3ppx12.8x6.7m, 5b1hset(1)-5b,1hr(2), 4530(1)-4130(2)hp, 15.3(1)-15(2)kts, 340p; 2x1-160/16MLR, 10x1-152/26, 2x1-76/20, 9x6-11.4, 2-356TC |
| | | 2 | Active | 1871 | | |
| Emerald | 2 | 3 | Ruby | 1877 |  | 2120t, 67.1ppx12.2x5.5m, 6b,2hce, 1833(3)-2005(4)hp, 12.3(3)-13.2(4)kts, 232p; 12x1-160/16MLR(3), 14x1-127/25(4), 8x1-11.4 |
| | | 4 | Garnet | 1878 | | |
| Bacchante | 1 | 5 | Boadicea | 1877 |  | 3913t, 85.3ppx13.7x7.2m, 10b,1hcrcr, 5134t, 14.8kts, 375p; 14x1-178/14MLR, 2x1-160/16MLR, 2x1-152/26, 7x1-76/20, 10x6-11.4, 2-356TC |
| Comus | 5 | 6 | Comus | 1879 |  | 2380t, 68.6ppx13.6x5.9m, 6b,1hce, 2420-2610hp, 12.9-13kts, 265p; steel: 13deck; 2x1-178/16MLR(7), 8x1-160/16MLR(6), 12x1-160/16MLR(7), 4x1-152/26(6,8,9), 10x1-152/26(10), 8x1-127/25(8,9), 2x1-76/19, 4x1-47/40(8), 1x1-47/40(9), 2-356TC |
| | | 7 | Curacoa | 1880 | | |
| | | 8 | Champion | 1880 | | |
| | | 9 | Cleopatra | 1880 | | |
| | | 10 | Cordelia | 1887 | | |
| Iris | 2 | 11 | Iris | 1879 |  | 3730t, 101.5(11)-96.0(12)x14.0x6.7m, 12b,2hdace, 6000hp, 17.5kts, 275p; 13x1-127/25, 4x1-47/40, 4-356TC |
| | | 12 | Mercury | 1879 | | |

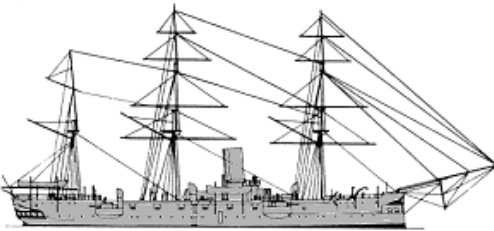
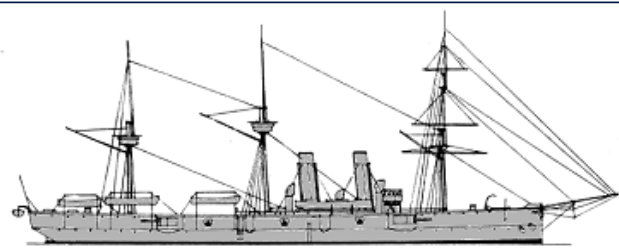
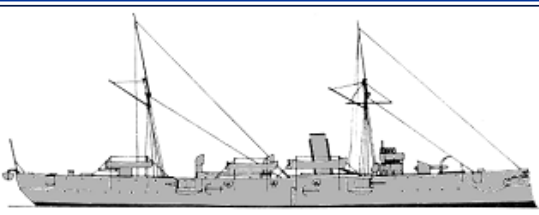
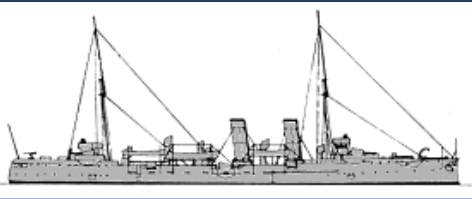
| | | | | | | |
|-----------|---|----|------------|------|--|---|
| | | | | |  | |
| Satellite | 6 | 13 | Satellite | 1883 |  | 1420t, 61.0ppx11.6x4.8m, 8b,1hce, 1400-1640hp, 13-13.1kts, 175-200p; steel: 25deck; 1x1-152/26(17), 8x1-152/26(13-16), 10x1-127/25(17), 14x1-127/25(18), 4x1-11.4(13-17), 8x1-11.4(18) |
| | | 14 | Heroine | 1883 | | |
| | | 15 | Hyacinth | 1884 | | |
| | | 16 | Royalist | 1886 | | |
| | | 17 | Rapid | 1884 | | |
| | | 18 | Pylades | 1886 | | |
| Calypso | 2 | 19 | Calypso | 1885 |  | 2770t, 71.6ppx13.6x6.1m, 6b,1hce, 3000hp, 13.7kts, 317p; steel: 13deck; 4x1-152/26, 12x1-127/25, 2x1-76/19, 10x1-11.4, 2-356TC |
| | | 20 | Calliope | 1887 | | |
| Leander | 4 | 21 | Leander | 1885 |  | 4300t, 96.0x14.0x6.3m, 12b,2hdace, 5500hp, 16.5kts, 278p; steel: 38deck, 38shields; 10x1-152/26, 4x1-47/40(21,23,24), 8x1-47/40(22), 6x4-25/40(21,23,24), 2x4-25/40(22), 2x6-11.4, 4x5-11.4, 4-356TC |
| | | 22 | Arethusa | 1887 | | |
| | | 23 | Phaeton | 1886 | | |
| | | 24 | Amphion | 1886 | | |
| Mersey | 4 | 25 | Mersey | 1887 |  | 4050t, 96.0x14.0x5.9m, 12b,2hdace, 6000hp, 18kts, 325p; steel: 76deck, 51shields, 229CT; 2x1-203/30, 10x1-152/26, 3x1-57/40, 3x1-47/40, 9x1-11.4, (2+2)-356TT/TC |
| | | 26 | Severn | 1888 | | |
| | | 27 | Thames | 1888 | | |
| | | 28 | Forth | 1889 | | |
| Medea | 5 | 29 | Magicienne | 1889 |  | 2950(29,32,33)-2800(30,31)t, 80.8ppx12.8(29,32,33)-12.5(30,31)x5.0m, 6b,2hdace(29,32,33)-6b,2vce(30,31), 9000hp, 19.7(29,32,33)-20(30,31)kts, 218p; steel: 51deck, 114shields, 76CT; 6x1-152/26, 9x1-57/40, 1x1-47/40, 3x1-11.4, (2+2)-356TT/TC |
| | | 30 | Medea | 1889 | | |
| | | 31 | Medusa | 1889 | | |
| | | 32 | Marathon | 1889 | | |
| | | 33 | Melpomene | 1889 | | |
| | | 34 | Latona | 1891 | | |

CL

| | | | | |
|---------|-------|------|---------------|------|
| Apollo | 21 | 35 | Melampus | 1891 |
| | | 36 | Andromache | 1891 |
| | | 37 | Terpsichore | 1892 |
| | | 38 | Naiad | 1892 |
| | | 39 | Thetis | 1892 |
| | | 40 | Sybillie | 1894 |
| | | 41 | Apollo | 1892 |
| | | 42 | Tribune | 1892 |
| | | 43 | Sappho | 1893 |
| | | 44 | Scylla | 1893 |
| | | 45 | Sirius | 1892 |
| | | 46 | Pique | 1893 |
| | | 47 | Spartan | 1892 |
| | | 48 | Indefatigable | 1892 |
| | | 49 | Rainbow | 1893 |
| | | 50 | Intrepid | 1892 |
| | | 51 | Brilliant | 1893 |
| | | 52 | Retribution | 1893 |
| | | 53 | Aeolus | 1894 |
| | | 54 | Iphigenia | 1893 |
| Astraea | 8 | 55 | Bonaventure | 1894 |
| | | 56 | Cambrian | 1894 |
| | | 57 | Astraea | 1895 |
| | | 58 | Charybdis | 1896 |
| | | 59 | Fox | 1896 |
| | | 60 | Hermione | 1896 |
| | | 61 | Flora | 1895 |
| 62 | Forte | 1895 | | |
| Eclipse | 9 | 63 | Eclipse | 1897 |
| | | 64 | Talbot | 1896 |
| | | 65 | Venus | 1897 |
| | | 66 | Minerva | 1897 |
| | | 67 | Juno | 1897 |
| | | 68 | Diana | 1897 |
| | | 69 | Doris | 1897 |
| | | 70 | Dido | 1898 |
| | | 71 | Isis | 1898 |
| | | 72 | Arrogant | 1898 |
| | | 73 | Furious | 1898 |

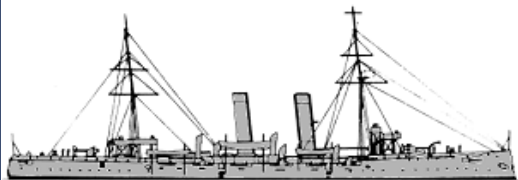

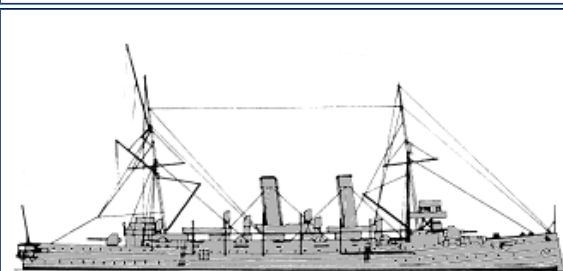

3400(34-44)-3600(45-54), 95.7x13.1(34-44)-13.3(45-54)x5.3(34-44)-5.6(45-54), 5b,2vte, 9000hp, 20(34-44)-19.7(45-54), 273p; steel: 51deck, 114shields, 76CT; 2x1-152/40, 6x1-120/40, 8x1-57/40, 1x1-47/40, 4x1-11.4, 4-356TT



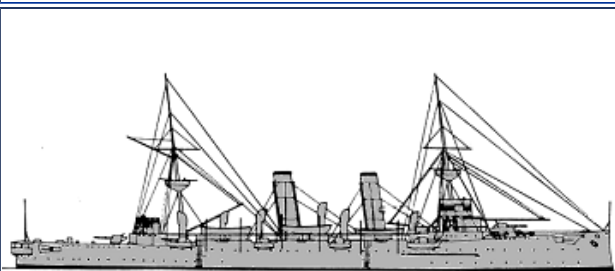



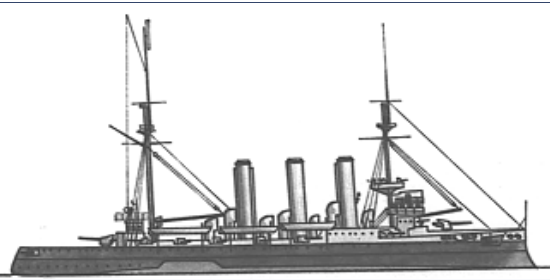
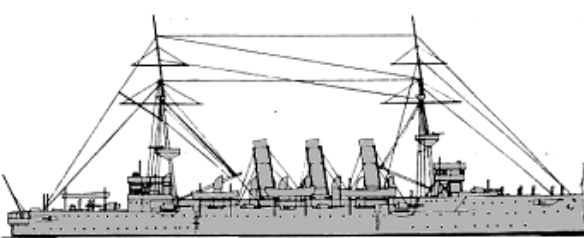
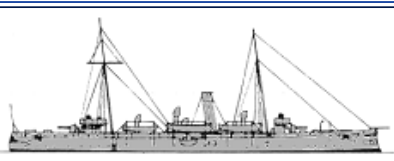

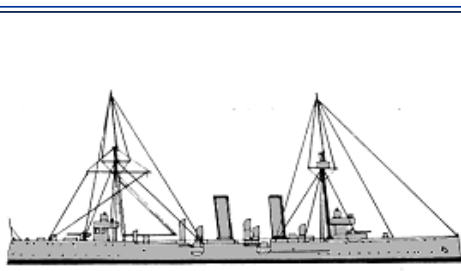
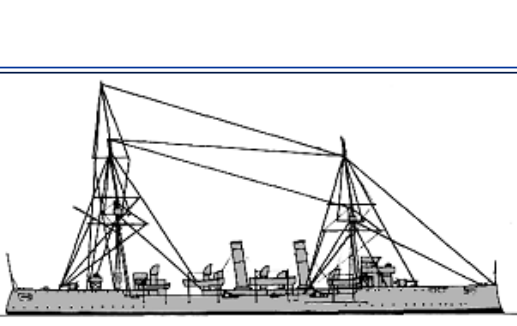

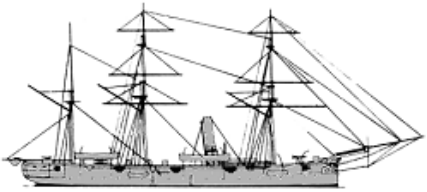
4360t, 103.5x15.1x5.8m, 8b,2vte, 9500hp, 19.5kts, 318p; steel: 51deck, 114shields, 76CT; 2x1-152/40, 8x1-120/40, 10x1-57/40, 1x1-47/40, 4-450TT

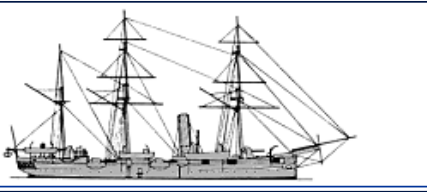



5600t, 113.7x16.3x6.3m, 8b,2vte, 9600hp, 19.5kts, 450p; Harvey: 76deck, 76shields, 152CT; 5x1-152/40, 6x1-120/40, 8x1-76/40, 6x1-47/40, 2x1-11.4, 3-450TT



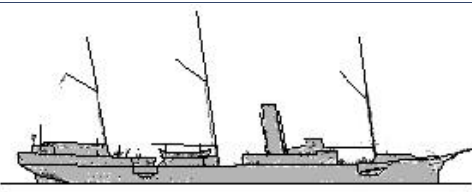
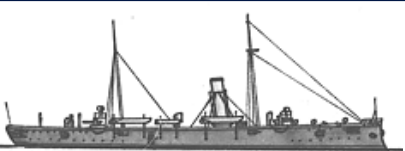
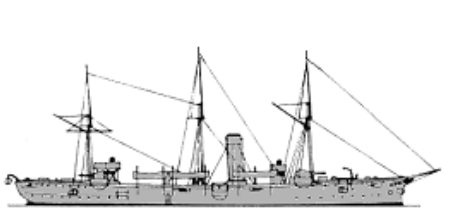





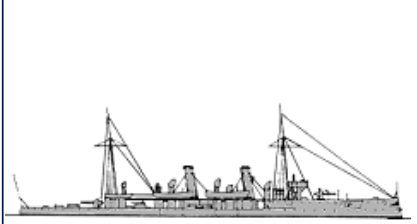

| | | | | | | | |
|-----|------------|---|----|------------|---|--|--|
| | Arrogant | 3 | | |  | 5750t, 104.2x17.5x6.1m, 18b,2vte, 10000hp, 19kts, 480p; Harvey: 76deck, 114shields, 229CT; 4x1-152/40, 6x1-120/40, 8x1-76/40, 3x1-47/40, 5x1-11.4, 3-450TT | |
| | | | 74 | Gladiator | | | 1899 |
| | Highflyer | 2 | 75 | Hermes | 1899 |  | 5650t, 113.4x16.5x6.3m, 18b,2vte, 10000hp, 20kts, 450p; Harvey: 76deck, 76shields, 152CT; 11x1-152/40, 9x1-76/40, 6x1-47/40, 2-450TT |
| | | | 76 | Highflyer | 1899 | | |
| CLL | Barracouta | 4 | 1 | Barrosa | 1890 |  | 1580t, 71.0x10.7x4.6m, 4b,2vte, 160p; steel: 51deck, 51shields; 6x1-120/40, 4x1-47/40, 2x1-11.4, 2-356TT |
| | | | 2 | Barracouta | 1891 | | |
| | | | 3 | Blanche | 1891 | | |
| | | | 4 | Blonde | 1891 | | |
| | Barham | 2 | 5 | Barham | 1891 |  | 1830t, 85.3ppx10.7x4.0m, 6b,2vte, 4700hp, 18kts, 169p; steel: 51deck, 51shields; 6x1-120/40, 4x1-47/40, 2x1-11.4, 2-356TT |
| | | | 6 | Bellona | 1891 | | |
| CLL | Pearl | 9 | 7 | Katoomba | 1891 |  | 2575t, 84.7x12.5x4.7m, 4b,2vte, 7500hp, 19kts, 217p; steel: 51deck, 51shields, 76CT; 8x1-120/40, 8x1-47/40, 4x1-11.4, (2+2)-356TT/TC |
| | | | 8 | Tauranga | 1891 | | |
| | | | 9 | Mildura | 1891 | | |
| | | | 10 | Ringarooma | 1891 | | |
| | | | 11 | Wallaroo | 1891 | | |
| | | | 12 | Pallas | 1891 | | |
| | | | 13 | Phoebe | 1892 | | |
| | | | 14 | Pearl | 1892 | | |
| | Pelorus | 6 | 16 | Proserpine | 1899 |  | 2135-2200t, 95.6x11.1x4.9m, 16b,2vte, 7000hp, 20kts, 224p; steel: 51deck, 76shields, 76CT; 8x1-102/40, 8x1-47/40, 3x1-7.7, 2-450TT |
| | | | 17 | Pelorus | 1897 | | |
| | | | 18 | Pactolus | 1898 | | |
| | | | 19 | Pegasus | 1898 | | |
| | | | 20 | Pomone | 1899 | | |
| | | | 21 | Prometheus | 1899 | | |











| | | | | | | | |
|---------|---------|----------|-----------|----------|--|---|--|
| SL | Osprey | 1 | Wild Swan | 1876 |  | 1130t, 58.8ppx11.0x4.8m, 3b,1hce, 1056hp, 12.2kts, 150p; 2x1-152/26, 6x1-127/25, 4x1-11.4 | |
| | | 2 | Pelican | 1877 | | | |
| | Doterel | 1 | 3 | Gannet | 1879 |  | 1130t, 58.8ppx11.0x4.8m, 3b1hce, 1107hp, 11.5kts, 150p; 2x1-178/16MLR, 2x1-127/25, 6x1-11.4 |
| | Mariner | 4 | 4 | Reindeer | 1884 |  | 970t, 50.9ppx9.9x4.3m, 3b,1hce, 970-1230hp, 11.5(4,5)-12.5(6,7)kts, 126p; 6x1-127/25(4), 8x1-127/25(5-7), 8x1-11.4 |
| | | 5 | Mariner | 1885 | | | |
| | | 6 | Icarus | 1886 | | | |
| | | 7 | Melita | 1889 | | | |
| | Nymphe | 4 | 8 | Swallow | 1886 |  | 1140t, 59.4ppx8.5x3.8m, 4b,2hte, 1570(1,4)-2000(2,3)hp, 13.5(1,4)-14.5(2,3)kts, 138p; 8x1-127/25, 8x1-11.4 |
| | | 9 | Buzzard | 1888 | | | |
| | | 10 | Nymphe | 1889 | | | |
| 11 | | Daphne | 1889 | | | | |
| Beagle | 2 | 12 | Beagle | 1889 |  | 1170t, 59.4ppx8.5x3.8m, 4b2hte, 2000hp, 14.5kts, 138p; steel: 37deck; 8x1-127/25, 4x4-25/40, 4x5-11.4 | |
| | 13 | Basilisk | 1889 | | | | |
| Alert | 2 | 14 | Alert | 1895 |  | 960t, 62.4x9.9x3.5m, 4b1vte, 1400hp, 13.2kts, 105p; 38deck; 6x1-102/40, 4x1-47/40, 2x1-11.4 | |
| | 15 | Torch | 1895 | | | | |
| Phoenix | 2 | 16 | Phoenix | 1896 |  | 1050t, 62.4x9.9x4.2m, 4b,1vte, 1400hp, 13kts, 106p; 6x1-102/40, 4x1-47/40, 3x1-11.4 | |
| | 17 | Algerine | 1896 | | | | |
| Condor | 1 | 18 | Rosario | 1899 |  | 980t, 62.2x9.9x3.5m, 4b,2vte, 1400hp, 13.5kts, 130p; steel: 38deck, 6shields; 6x1-102/40, 4x1-47/40 | |
| | | 1 | Surprise | 1886 | | | |















| | | | | | | | |
|----|----------|---|---|----------|------|--|--|
| DV | Surprise | 2 | 2 | Alacrity | 1886 |  | 1650-1700t, 83.9x9.9x4.0m, 4b,2hdace, 3030hp, 17kts, 93p; steel: 10deck; 4x1-127/25(12), 4x1-57/40(12), 10x1-57/40(13), 2x1-11.4(12) |
| CT | Scout | 2 | 1 | Scout | 1886 |  | 1580t, 68.6x10.4x4.4m, 4b,2hdace, 3200hp, 17kts, 147p; steel: 10deck, 25shields, 76TT; 4x1-120/40, 8x1-47/40, 2x1-11.4, (3+4)-356TT/TC |
| | | | 2 | Fearless | 1887 | | |
| | Archer | 7 | 3 | Archer | 1887 |  | 1950t, 73.2x11.0x4.4m, 4b,2hdace, 3500(3-8)-4500(9)hp, 16.5(3-8)-17.5(9)kts, 176p; steel: 10deck, 25shields, 76CT; 6x1-152/26, 8x1-47/40, 2x1-11.4, (1+4)-356TT/TC |
| | | | 4 | Mohawk | 1887 | | |
| | | | 5 | Brisk | 1888 | | |
| | | | 6 | Porpoise | 1888 | | |
| | | | 7 | Cossack | 1888 | | |
| | | | 8 | Tartar | 1888 | | |
| | | | 9 | Racoon | 1888 | | |

















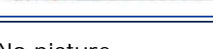

TORPEDO SHIPS



| | | | | | | | |
|----|--------------|------|------------|--------------|------|--|---|
| RT | Polyphemus | 1 | 1 | Polyphemus | 1882 |  | 73.2ppx12.2x6.3m, 4b,2hce, 7000hp, 18kts, 146p; steel: 76deck; 6x1-57/40, 5-356TT |
| | Rattlesnake | 1 | 1 | Rattlesnake | 1887 |  | 550t, 61.0ppx7.0x3.2m, 4b,2vte, 2700hp, 19.2kts, 66p; steel: 19deck; 1x1-102/27, 6x1-47/40, (2+2x1)-356TT |
| | Grasshopper | 3 | 2 | Grasshopper | 1888 |  | 526t, 61.0ppx7.0x3.2m, 4b,2vte, 2700hp, 19.2kts, 66p; 1x1-102/27, 6x1-47/40, (2+2x1)-356TT |
| | | | 3 | Sandfly | 1888 | | |
| | | | 4 | Spider | 1888 | | |
| | Sharpshooter | 13 | 5 | Sharpshooter | 1889 |  | 735t, 70.1ppx8.2x3.2m, 4b,2vte, 3600hp, 19kts, 91p; 2x1-120/40, 4x1-47/40, (1+2x2)-356TT |
| | | | 6 | Spanker | 1890 | | |
| | | | 7 | Speedwell | 1890 | | |
| | | | 8 | Sheldrake | 1890 | | |
| | | | 9 | Skipjack | 1891 | | |
| | | | 10 | Seagull | 1891 | | |
| 11 | | | Salamander | 1891 | | | |
| 12 | Gleaner | 1891 | | | | | |

| PGT | | | | | | |
|---------|----|----|-----------|------|--|--|
| Alarm | 11 | 13 | Gossamer | 1891 |  | 810t, 70.1ppx8.2x3.7m, 4b,3vte, 3500(14-22,24)-5000(23)hp, 18.7(14-22,24)-20.5(23)kts, 91p; 2x1-120/40, 4x1-47/40, 1x5-11.4, (1+2x1)-356TT(14,17,20,22,23), (1+2x2)-356TT(15,16,18,19,21,24) |
| | | 14 | Jason | 1893 | | |
| | | 15 | Circe | 1893 | | |
| | | 16 | Hebe | 1894 | | |
| | | 17 | Onyx | 1894 | | |
| | | 18 | Leda | 1893 | | |
| | | 19 | Alarm | 1894 | | |
| | | 20 | Jaseur | 1893 | | |
| | | 21 | Renard | 1894 | | |
| | | 22 | Niger | 1893 | | |
| | | 23 | Speedy | 1894 | | |
| | | 24 | Antelope | 1894 | | |
| Dryad | 5 | 25 | Dryad | 1894 |  | 1070t, 80.1x9.3x3.5m, 4b,2vte, 6000hp, 20kts, 120p; 2x1-120/40, 4x1-57/40, 1x5-11.4, (1+4x1)-450TT |
| | | 26 | Hazard | 1894 | | |
| | | 27 | Harrier | 1895 | | |
| | | 28 | Halcyon | 1895 | | |
| | | 29 | Hussar | 1895 | | |
| Havock | 2 | 1 | Havock | 1894 |  | 275t, 56.4x5.7x2.2m, 2b,2vte(1)-8b,2vte(2), 3800hp, 26kts, 46p; 1x1-76/40, 3x1-57/40, (1+2x1)-450TT |
| | | 2 | Hornet | 1894 | | |
| Daring | 2 | 3 | Daring | 1895 |  | 288t, 56.4x5.8x2.1m, 3b,2vce, 3200hp, 27kts, 48p; 1x1-76/40, 3x1-57/40, (1+2x1)-450TT |
| | | 4 | Decoy | 1895 | | |
| Ferret | 2 | 5 | Ferret | 1895 |  | 280t, 60.1x6.0x2.7m, 4b,2vte, 4475hp, 27.2kts, 46p; 1x1-76/40, 3x1-57/40, (1+2x1)-450TT |
| | | 6 | Lynx | 1895 | | |
| Ardent | 3 | 7 | Ardent | 1895 |  | 295t, 61.5x5.8x2.2m, 3b,2vte, 4500(7,9)-4200(8)hp, 28(7)-29(8)-30(9)kts, 53p; 1x1-76/40, 5x1-57/40, 2x1-450TT |
| | | 8 | Boxer | 1895 | | |
| | | 9 | Bruizer | 1895 | | |
| Janus | 3 | 10 | Janus | 1895 |  | 320t, 61.1x5.9x2.4m, 4b,2vte, 3900hp, 28kts, 54p; 1x1-76/40, 5x1-57/40, 2x1-450TT |
| | | 11 | Lightning | 1896 | | |
| | | 12 | Porcupine | 1896 | | |
| Banshee | 3 | 13 | Banshee | 1895 |  | 345t, 64.9x5.9x2.9m, 4b,2vte, 4400hp, 28kts, 58p; 1x1-76/40, 5x1-57/40, 2x1-450TT |
| | | 14 | Contest | 1895 | | |
| | | 15 | Dragon | 1895 | | |
| Handy | 3 | 16 | Handy | 1895 |  | 310t, 60.1x5.9x2.3m, 3b,2vte, 4000hp, 27kts, 55p; 1x1-76/40, 5x1-57/40, 2x1-450TT |
| | | 17 | Hart | 1896 | | |
| | | 18 | Hunter | 1896 | | |
| Rocket | 3 | 19 | Rocket | 1895 |  | 325t, 62.2x6.0x2.21m, 4b,2vte, 4100hp, 27kts, 58p; 1x1-76/40, 5x1-57/40, 2x1-450TT |
| | | 20 | Shark | 1895 | | |
| | | 21 | Surly | 1895 | | |



| | | | | | | | |
|---------|-----------|----|----------|-------------|--|--|---|
| DD | Charger | 3 | 22 | Charger | 1896 |  | 295t, 59.4x5.6x2.2m, 4b,2vte, 3100(22,23)-3800(24)hp, 26.2kts, 53p; 1x1-76/40, 5x1-57/40, 2x1-450TT |
| | | | 23 | Hasty | 1896 | | |
| | | | 24 | Dasher | 1896 | | |
| | Haughty | 2 | 25 | Haughty | 1896 |  | 325t, 61.0x5.9x2.4m, 8b,2vte, 4200hp, 27kts, 54p; 1x1-76/40, 5x1-57/40, 2x1-450TT |
| | | | 26 | Hardy | 1896 | | |
| | Salmon | 2 | 27 | Salmon | 1896 |  | 340t, 61.5x6.0x2.4m, 8b,2vte, 3700hp, 27kts, 52p; 1x1-76/40, 5x1-57/40, 2x1-450TT |
| | | | 28 | Snapper | 1896 | | |
| | Sunfish | 3 | 29 | Sunfish | 1896 |  | 340t, 62.2x5.8x2.6m, 8b,2vte, 4000hp, 27kts, 58p; 1x1-76/40, 5x1-57/40, 2x1-450TT |
| | | | 30 | Opossum | 1896 | | |
| | | | 31 | Ranger | 1896 | | |
| | Sturgeon | 3 | 32 | Sturgeon | 1896 |  | 340t, 59.3x5.8x2.3m, 4b,2vte, 4000hp, 27.8kts, 52p; 1x1-76/40, 5x1-57/40, 2x1-450TT |
| | | | 33 | Starfish | 1896 | | |
| | | | 34 | Skate | 1896 | | |
| | Swordfish | 2 | 35 | Swordfish | 1896 |  | 355t, 62.3x5.8x2.4m, 8b,2vte, 4500hp, 27kts, 58p; 1x1-76/40, 5x1-57/40, 2x1-450TT |
| | | | 36 | Spitfire | 1896 | | |
| | Desperate | 4 | 37 | Desperate | 1897 |  | 350t, 64.0x6.0x2.1m, 3b,2vte, 5700hp, 30kts, 54p; 1x1-76/40, 5x1-57/40, 2x1-450TT |
| | | | 38 | Fame | 1897 | | |
| | | | 39 | Foam | 1897 | | |
| | | | 40 | Mallard | 1897 | | |
| | Quail | 4 | 41 | Quail | 1897 |  | 415t, 66.5x6.6x2.9m, 4b,2vte, 6300hp, 30kts, 56p; 1x1-76/40, 5x1-57/40, 2x1-450TT |
| | | | 42 | Sparrowhawk | 1897 | | |
| 43 | | | Thrasher | 1897 | | | |
| 44 | | | Virago | 1897 | | | |
| Avon | 2 | 45 | Avon | 1899 |  | 405t, 65.3x6.1x2.5m, 4b,2vte, 6300hp, 30kts, 60p; 1x1-76/40, 5x1-57/40, 2x1-450TT | |
| | | 46 | Bittern | 1897 | | | |
| Earnest | 6 | 47 | Earnest | 1897 |  | 415t, 66.5x6.6x3.0m, 4b,2vte, 6300hp, 30kts, 56p; 1x1-76/40, 5x1-57/40, 2x1-450TT | |
| | | 48 | Griffon | 1897 | | | |
| | | 49 | Locust | 1898 | | | |
| | | 50 | Panther | 1898 | | | |
| | | 51 | Seal | 1898 | | | |
| | | 52 | Wolf | 1898 | | | |
| Star | 6 | 53 | Star | 1898 |  | 440t, 67.1x6.4x3.0m, 4b,2vte, 6200hp, 30kts, 58p; 1x1-76/40, 5x1-57/40, 2x1-450TT | |
| | | 54 | Whiting | 1897 | | | |
| | | 55 | Bat | 1897 | | | |
| | | 56 | Crane | 1898 | | | |
| | | 57 | Chamois | 1897 | | | |



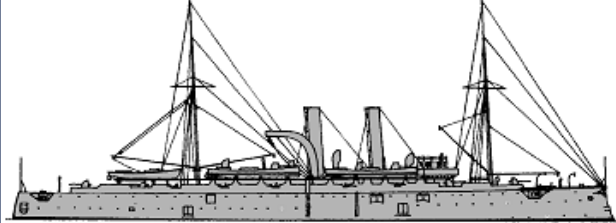

| | | | | | | |
|----------|---|---------|--------------|-------------|--|--|
| | | 58 | Flying Fish | 1898 | | |
| Angler | 2 | 59 | Angler | 1898 |  | 352t, 64.0x6.0x2.1m, 3b,2vte, 5700hp, 30kts, 54p; 1x1-76/40, 5x1-57/40, 2x1-450TT |
| | | 60 | Ariel | 1898 | | |
| Violet | 2 | 61 | Violet | 1898 |  | 400t, 65.2(61)-65.5(62)x6.4x2.9m, 4b,2vte, 6300hp, 30kts, 58p; 1x1-76/40, 5x1-57/40, 2x1-450TT |
| | | 62 | Sylvia | 1899 | | |
| Gipsy | 3 | 63 | Gipsy | 1898 |  | 400t, 65.7x6.5x2.5m, 4b,2vte, 6300hp, 30kts, 60p; 1x1-76/40, 5x1-57/40, 2x1-450TT |
| | | 64 | Osprey | 1898 | | |
| | | 65 | Fairy | 1898 | | |
| Fawn | 2 | 66 | Fawn | 1898 |  | 440t, 67.1x6.4x3.0m, 4b,2vte, 6200hp, 30kts, 58p; 1x1-76/40, 5x1-57/40, 2x1-450TT |
| | | 67 | Flirt | 1899 | | |
| Conflict | 3 | 68 | Conflict | 1899 |  | 360t, 62.7x6.1x2.5m, 3b,2vte, 4500hp, 27kts, 54p; 1x1-76/40, 5x1-57/40, 2x1-450TT |
| | | 69 | Teazer | 1899 | | |
| | | 70 | Wizard | 1899 | | |
| Cheerful | 1 | 71 | Mermaid | 1899 |  | 400t, 65.5x6.4x2.5m, 4b,2vte, 6100hp, 30kts, 58p; 1x1-76/40, 5x1-57/40, 2x1-450TT |
| Coquette | 2 | 72 | Coquette | 1899 |  | 367t, 64.0x6.0x2.3m, 3b,2vte, 5700hp, 30kts, 54p; 1x1-76/40, 5x1-57/40, 2x1-450TT |
| | | 73 | Cynthia | 1899 | | |
| Leopard | 1 | 74 | Leopard | 1899 |  | 400t, 65.3x6.1x2.5m, 4b,2vte, 6300hp, 30kts, 60p; 1x1-76/40, 5x1-57/40, 2x1-450TT |
| Leven | 1 | 75 | Leven | 1899 |  | 420t, 65.7x6.5x2.5m, 4b,2vte, 6100hp, 30kts, 58p; 1x1-76/40, 5x1-57/40, 2x1-450TT |
| TB2 | 9 | 1 - 9 | TB3, 4, 6-12 | 1878 - 1880 |  | 33t, 26.5(1-6,8,9)-27.9(7)x3.1x1.6m, 1b,1hce, 460hp, 20kts, 15p; 2-356TC |
| TB17 | 2 | 10 - 11 | TB17, 18 | 1878 |  | 33t, 26.2x3.4x1.4m, 1b,1hce, 450hp, 21kts, 15p; 2-356TC |
| TB14 | 1 | 12 | TB14 | 1879 |  | 33t, 26.2x3.4x1.4m, 1b1hce, 550hp, 21.7kts, 15p; 2-356TC |
| TB15 | 1 | 13 | TB15 | 1879 |  | 28t, 26.5x3.1x1.7m, 1b,1hce, 450hp, 21kts, 15p; 2-356TC |
| TB20 | 1 | 14 | TB20 | 1880 |  | 28t, 26.5x3.1x1.2m, 1b,1hce, 360hp, 16.7kts, 15p; 2-356TC |
| TB21 | 2 | 15, 16 | TB21, 22 | 1885 |  | 63t, 34.6x3.8x1.8m, 1b,1hce, 730hp, 18kts, 14p; 2x1-25/40, (2+1x1)-356TT |



| | | | | | | | |
|----|----------|----|---------|------------------------------------|----------------------|---|--|
| TB | TB23 | 2 | 17, 18 | TB23, 24 | 1886 |  | 67t, 34.6x3.8x2.1m, 1b,1hce, 600(17)-500(18)hp, 18.7kts, 14p; 2x1-47/40, (2+1x1)-356TT |
| | TB25 | 1 | 19 | TB25 | 1886 |  | 60t, 39.1x3.8x1.8m, 1b,1hce, 591hp, 19.4kts, 16p; 3x2-25/40, 2x2-356TT |
| | TB26 | 23 | 20 - 42 | TB26, 27, 29, 41-60 | 1886 - 1887 |  | 60t, 38.9x3.8x2.5m, 1b,1hce, 700-750hp, 19.5-21.5kts, 16p; 3x2-25/40, 2x2-356TT |
| | TB30 | 21 | 43 - 63 | TB30-33, 61-74, 76-78 | 1886 - 1887 |  | 60t, 38.2x4.0x2.5m, 1b,1hce, 670hp, 19.5kts, 16p; 2x1-25/40, (1+2x2)-356TT |
| | TB34 | 5 | 64 - 68 | TB34-38 | 1886 - 1887 |  | 60(64-66)-66(67,68)t, 38.1pp(64-66)-40.3pp(67,68)x4.4x1.3m, 1b,1hce, 950hp, 18-19kts, 16p; 2x1-47/40(67,68), 2x1-25/40(64-66), (1+2x2)-356TT |
| | TB79 | 1 | 69 | TB79 | 1886 |  | 75t, 39.2x4.0x1.7m, 1b,1vte, 1000hp, 22.2kts, 16p; 2x1-47/40, (2+1x1)-356TT |
| | TB80 | 1 | 70 | TB80 | 1887 |  | 105t, 41.2ppx4.3x1.8m, 2b,1vte, 1539hp, 23kts, 21p; 3x1-47/40, (1+1x2)-356TT |
| | TB39 | 2 | 71, 72 | TB39, 40 | 1885 | No picture | 40t, 30.5ppx3.8x1.2m, 1b,1hce, 500hp, 15p; 2x2-25/40, 1x1-356TT |
| | Baluchi | 3 | 73 - 75 | TB1 Baluchi, TB2 Karen, TB3 Pathan | 1888 |  | 96t, 41.0x4.5x2.1m, 2b,1hce, 1260hp, 23kts, 18p; 2x2-25/40, (1+2x2)-356TT |
| | Gurkha | 1 | 76 | TB7 Gurkha | 1888 |  | 92t, 41.2x4.3x2.1m, 2b,1hce, 1000hp, 21.5kts, 18p; 2x2-25/40, (1+2x2)-356TT |
| | Mahratta | 3 | 77 - 79 | TB4 Mahratta, TB5 Sikh, TB6 Rajput | 1889 |  | 95t, 41.2x4.4x2.3m, 2b,1hce, 1000hp, 22kts, 18p; 2x2-25/40, (1+2x2)-356TT |
| | TB82 | 6 | 80 - 85 | TB82-87 | 1889 |  | 85t, 39.7ppx4.1x1.8m, 1b,1vte, 1800hp, 23kts, 19p; 3x1-47/40, (1+1x2)-356TT |
| | TB88 | 2 | 86 - 87 | TB88 TB89 | 1894 1894 |  | 112t, 43.3ppx4.5x2.3m, 1b,1vte, 1850hp, 23.5kts, 18p; 3x1-47/40, (1+1x2)-450TT |
| | TB91 | 2 | 88 - 89 | TB91 TB92 | 1894 1894 |  | 141t, 43.3(89)-42.8(90)x4.7x2.3m, 1b,1vte, 2350hp, 24.5kts, 18p; 3x1-47/40, (1+1x2)-450TT |
| | TB93 | 1 | 90 | TB93 | 1894 |  | 136t, 42.8x4.7x1.6m, 2b,2vte, 2200hp, 23.5kts, 18p; 3x1-47/40, (1+1x2)-450TT |
| | TB94 | 3 | 91 - 93 | TB94 TB95 TB96 | 1894 1895 1895 |  | 130t, 43.4ppx4.7x2.7m, 2b,2vte, 2000hp, 23kts, 18p; 3x1-47/40, (1+1x2)-450TT |
| | TB97 | 1 | 94 | TB97 | 1894 |  | 130t, 42.8ppx4.9x2.3m, 2b,2vte, 2000hp, 23kts, 18p; 3x1-47/40, (1+1x2)-450TT |
| | TB90 | 1 | 95 | TB90 | 1895 |  | 112t, 42.8ppx4.4x2.0m, 1b,1vte, 1500hp, 23kts, 18p; 3x1-47/40, (1+1x2)-450TT |
| | TB51 | 11 | 1 - | TB51-61 | 1878 - |  | 11t, 18.5x2.3x0.9m, 1b,1hce, 120-150hp, 15kts, 7p; 2-356TC |

| | | | | | | | |
|-------|--------|----|---------|------------------------|-------------|---|---|
| TB2cl | | | 11 | | 1879 | | |
| | TB63 | 1 | 12 | TB63 | 1878 |  | 15t, 18.3x2.3xm, 1b,1hce, hp, 16kts, 7p; 2-356TC |
| | TB64 | 8 | 13 - 20 | TB64-67, 69-71, 73 | 1880 - 1882 | No picture | 13t, 19.2-20.1ppx2.4x1.0m, 1b,1hce, 110hp, 16.5kts, 7p; 2-356TC |
| | TB76 | 18 | 21 - 38 | TB76-82, 84-92, 94, 95 | 1882 - 1883 | No picture | 13t, 19.5x2.3x1.1m, 1b,1hce, 170hp, 16.5kts, 7p; 2-356TT |
| | TB74 | 4 | 39 - 42 | TB74, 75, 96, 97 | 1883 | No picture | 12t, 18.5pp-19.4ppx2.4x1.1m, 1b,1hce, 220hp, 16kts, 7p; 1x1-11.4, 2-356TT |
| | TB98 | 1 | 43 | TB98 | 1883 | No picture | 15t, 22.2x2.3x0.8m, 1b,1hce, 167hp, 11.7kts, 7p; 2-356TT |
| | WTB1 | 12 | 44 - 55 | WTB1-12 | 1883 - 1888 | No picture | 11-14t, 17.1x2.8x1.5m, 1b,1hce, 140-200hp, 16kts, 9p; (1-2)x1-11.4, 1-356TT or 2-356TC or 1x1-356TT |
| | TB99 | 2 | 56, 57 | TB99, 100 | 1885 - 1886 | No picture | 12t, 19.8x2.4x1.1m, 1b,1hce, 189hp, 16.8kts, 7p; 2-356TT |
| | TB49 | 2 | 58, 59 | TB49, 50 | 1888 |  | 15-16t, 18.1pp-18.3ppx2.5-2.6x0.9m, 1b,1vte, 9p; 1x1-25/40, 1x1-356TT |
| | TB39 | 10 | 60 - 69 | TB39 - 48 | 1889 |  | 17t, 18.3ppx2.8xm, 1b,1vte, 240hp, 16.5kts, 9p; 1x1-25/40, 2-356TC |
| CTB | Hecla | 1 | 1 | Hecla | 1879 | No picture | 6400t, 119.6ppx11.8x6.9m, b,2hice, 1758hp, 12.1kts, 277p; 4x1-160/16MLR, 1x1-127/25, 1x1-121/21, 4 TB2cl |
| | Vulcan | 1 | 2 | Vulcan | 1891 |  | 6620t, 113.7x17.7x6.7m, 5b,2vte, 12000hp, 20kts, 432p; steel: 127deck, 152CT; 8x1-120/40, 12x1-47/40, 12x1-11.4, 6TT, 9 TB2cl |

OTHER FIGHTING SHIPS

| | | | | | | |
|---------|---|---|---------|------|---|--|
| Staunch | 1 | 1 | Staunch | 1868 |  | 200t, 22.9x7.6x2.0m, 1b,2hse, 134hp, 7.7kts, 31p; 1x1-229MLR |
| Plucky | 1 | 2 | Plucky | 1870 |  | 212t, 24.4x7.7x1.9m, 1b,2hse, 234hp, 7.7kts, 31p; 1x1-229MLR |
| | | 3 | Blazer | 1870 | | |
| | | 4 | Comet | 1870 | | |
| | | 5 | Bustard | 1871 | | |
| | | 6 | Kite | 1871 | | |
| | | 7 | Scourge | 1871 | | |

| | | | | | | | | | | |
|-----------|--------|----------|------------|------|--|---|-----------|------|---|---|
| Ant | 23 | 8 | Mastiff | 1871 |  | 254t, 25.9x8.0x1.8-2.0m, 1b,2hse(t), 260hp, 8.5kts, 30p; 1x1-254MLR | | | | |
| | | 9 | Bloodhound | 1871 | | | | | | |
| | | 10 | Arrow | 1871 | | | | | | |
| | | 11 | Bonetta | 1871 | | | | | | |
| | | 12 | Badger | 1872 | | | | | | |
| | | 13 | Fidget | 1872 | | | | | | |
| | | 14 | Bulldog | 1872 | | | | | | |
| | | 15 | Pike | 1872 | | | | | | |
| | | 16 | Pickle | 1872 | | | | | | |
| | | 17 | Snap | 1872 | | | | | | |
| | | 18 | Ant | 1873 | | | | | | |
| | | 19 | Cuckoo | 1873 | | | | | | |
| | | 20 | Hyaena | 1873 | | | | | | |
| | | 21 | Weazel | 1873 | | | | | | |
| | | 22 | Gadfly | 1879 | | | | | | |
| | | 23 | Pincher | 1879 | | | | | | |
| | | 24 | Griper | 1879 | | | | | | |
| | | 25 | Tickler | 1879 | | | | | | |
| | | Ariel | 1 | 26 | | | Goshawk | 1873 | No picture | 430t, 38.1ppx6.9x3.2m, 2b,1hce, 484hp, 9.5kts, 40p; 2x1-127/25, 2x1-95/21 |
| | | Forester | 3 | 27 | | | Firm | 1877 |  | 455t, 38.1ppx7.2x3.2m, 2b,2hce, 500hp, 10kts, 60p; 2x1-127/25, 2x1-95/21 |
| | | | | 28 | | | Firebrand | 1877 | | |
| | | | | 29 | | | Firefly | 1877 | | |
| | | Medina | 11 | 30 | | | Medina | 1876 |  | 363t, 33.5x10.4x1.8m, 1b,2hse, 310hp, 9.5kts, 51p; 3x1-160/16MLR |
| | | | | 31 | | | Medway | 1876 | | |
| | | | | 32 | | | Sabrina | 1876 | | |
| 33 | Spey | | | 1876 | | | | | | |
| 34 | Tay | | | 1876 | | | | | | |
| 35 | Tees | | | 1876 | | | | | | |
| 36 | Don | | | 1877 | | | | | | |
| 37 | Esk | | | 1877 | | | | | | |
| 38 | Slaney | | | 1877 | | | | | | |
| 39 | Trent | | | 1877 | | | | | | |
| 40 | Tweed | | | 1877 | | | | | | |
| PG Linnet | 2 | 41 | Swift | 1880 |  | 788t, 50.3ppx8.8x3.3m, 4b,1hce, 1010-1050hp, 11.8kts, 92p; 2x1-178/14MLR, 3x1-95/21 | | | | |
| | | 42 | Linnet | 1880 | | | | | | |

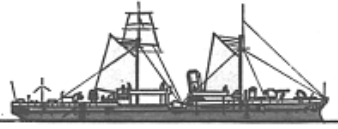
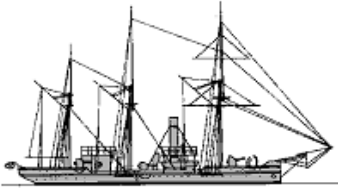
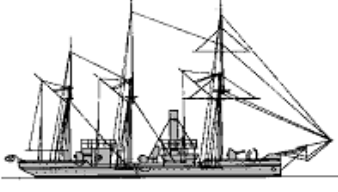
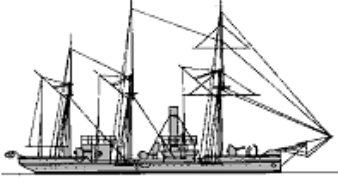
| | | | | | | |
|-----------|---------|------|------------|------|--|--|
| Banterer | 7 | 43 | Redwing | 1880 |  | 465t, 38.1ppx7.2x3.1m, 4b,1hce, 440hp, 9.5kts, 60p; 2x1-127/25, 2x1-95/21, 2x1-25/40 |
| | | 44 | Grappler | 1881 | | |
| | | 45 | Banterer | 1882 | | |
| | | 46 | Espoir | 1883 | | |
| | | 47 | Bullfrog | 1885 | | |
| | | 48 | Cockchafer | 1883 | | |
| | | 49 | Raven | 1883 | | |
| Bouncer | 2 | 50 | Bouncer | 1881 |  | 265t, 26.6x8.0x2.0m, 1b,2hse, 230hp, 8.5kts, 30p; 1x1-254/15MLR |
| | | 51 | Insolent | 1881 | | |
| Handy | 1 | 52 | Excellent | 1883 | No picture | 508t, 35.1x11.3x2.8m, 2b,2hse, 310hp, 8.5kts; 1x1-343/30 |
| Albacore | 3 | 53 | Albacore | 1884 |  | 560t, 41.2ppx7.9x2.6m, 4b,1vce, 650hp, 10.7kts, 60p; 2x1-127/25, 2x1-102/27, 2x1-25/40 |
| | | 54 | Mistletoe | 1884 | | |
| | | 55 | Watchful | 1884 | | |
| Curlew | 2 | 56 | Curlew | 1886 |  | 950t, 59.4ppx8.5x3.2m, 4b,2hdace, 1500hp, 14.5kts, 46p; 1x1-152/26, 3x1-127/25, 7x1-11.4, (1+2)-356TT/TC |
| | | 57 | Landrail | 1887 | | |
| Bramble | 3 | 58 | Rattler | 1887 |  | 810t, 50.3ppx8.8x3.4m, 2b,1vte, 1200(57)-1000(58,59)hp, 13kts, 76p; 6x1-102/40, 4x1-11.4 |
| | | 59 | Lizard | 1887 | | |
| | | 60 | Cockatrice | 1887 | | |
| Pigmy | 6 | 61 | Pheasant | 1888 |  | 755t, 50.3ppx9.1x3.4m, 2b,1vte, 1200hp, 13.2kts, 76p; 6x1-102/27, 4x1-11.4 |
| | | 62 | Partridge | 1888 | | |
| | | 63 | Peacock | 1888 | | |
| | | 64 | Pigmy | 1889 | | |
| | | 65 | Pigeon | 1889 | | |
| | | 66 | Plover | 1889 | | |
| Redbreast | 9 | 67 | Goldfinch | 1889 |  | 805t, 50.3ppx9.5x3.4m, 2b,1vte, 1200hp, 13kts, 76p; 6x1-102/27(63,65-71), 6x1-102/28(64), 2x1-47/40(63,64,69-71), 4x1-11.4(65-68), 2x1-11.4(63,64,69-71) |
| | | 68 | Lapwing | 1889 | | |
| | | 69 | Magpie | 1889 | | |
| | | 70 | Redbreast | 1889 | | |
| | | 71 | Redpole | 1890 | | |
| | | 72 | Ringdove | 1890 | | |
| | | 73 | Sparrow | 1890 | | |
| | | 74 | Thrush | 1890 | | |
| 75 | Widgeon | 1890 | | | | |

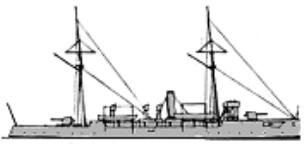
| | | | | | | | | |
|-----|---------|---|-----|--------------------------------------|----------|---|---|---|
| | Bramble | 1 | 76 | Dwarf | 1899 |  | 710t, 57.2x10.1x2.4m, 4b,2vte, 1300hp, 13.5kts, 85p; 2x1-102/40, 4x1-76/40, 10x1-11.4 | |
| APG | - | 2 | 1 | Lady Loch | 1886 | | 336t; 1x1-152/26 | |
| | | | 2 | Otter | 1884 | | 220t | |
| PGR | Heron | 4 | 1-4 | Nightingale, Robin, Sandpiper, Snipe | 1898 | No picture | 85t, 32.8x6.1x0.6m, 1b,1vte, 240hp, 9kts, 25p; 2x1-57/40 | |
| | | | 2 | 5 | Woodcock | 1898 | No picture | 150t, 44.2x7.3x0.6m, 1b,1vte, 550hp, 13kts, 25p; 2x1-57/40, 4x1-7.9 |
| | | | | 6 | Woodlark | 1898 | | |



© Ivan Gogin, 2014

[home](#)[World navies yesterday](#)[1900](#)







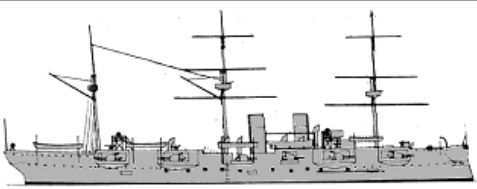
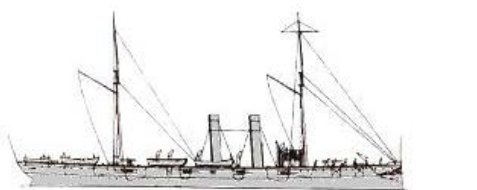
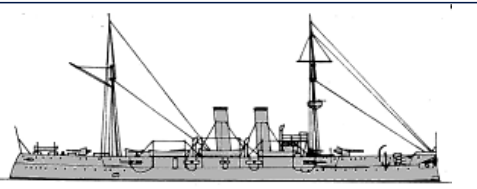
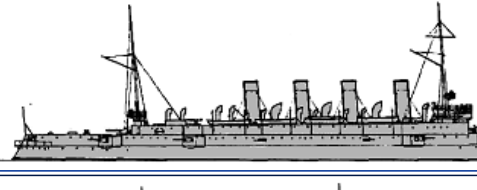
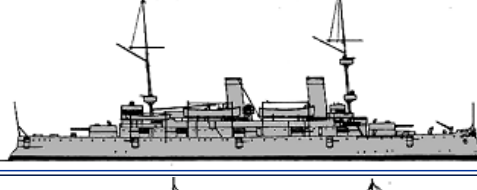
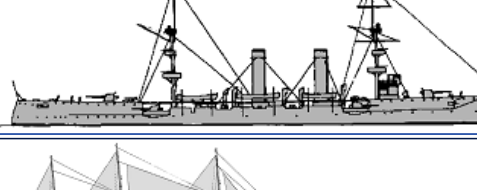
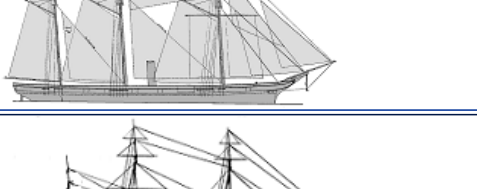
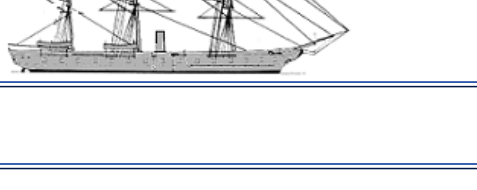

United States of America 01 January 1900

CAPITAL SHIPS

| | | | | | | | |
|----------|------------|----|-------------|---------------|------|--|--|
| BB | Texas | 1 | 1 | Texas | 1895 | | 6665t, 94.1x19.5x6.9m, 4b,2vte, 8600hp, 17kts, 392p; Harvey: 305belt, 76deck, 305turrets, 305CT; 2x1-305/35, 2x1-152/35, 4x1-152/30, 10x1-57/45, 2x1-57/40, 6x1-37/40, 4x5-37/20, 4-356TT |
| | Indiana | 2 | B1 | Indiana | 1895 | | 11688t, 107.0x21.1x7.3m, 6b,2vte, 9000hp, 15kts, 473p; Harvey: 457belt, 76deck, 432turrets, 254CT; 2x2-330/35, 4x2-203/37, 4x1-152/40, 20x1-57/40, 6x5-37/20, 6-450TT |
| | | 3 | B2 | Massachusetts | 1896 | | |
| | | 4 | B3 | Oregon | 1896 | | |
| Iowa | 1 | 5 | B4 | Iowa | 1897 | | |
| MON | Passaic | 1 | | Catskill | 1863 | | 1875t, 61.0x14.0x3.2m, 2b,1vl, 320hp, 7kts, 75p; iron: 127side, 51deck, 279turret; 1x2-381/11, 2x1-76/11 |
| | | 2 | | Lehigh | 1863 | | |
| | | 3 | | Montauk | 1862 | | |
| | | 4 | | Nahant | 1862 | | |
| | | 5 | | Nantucket | 1863 | | |
| | | 6 | | Jason | 1863 | | |
| | Canonicus | 7 | | Canonicus | 1864 | | 2100t, (68.0-68.6)x(13.1-13.2)x(3.8-4.0)m, 2b,1vl, 320hp, 8kts, 100p; iron: 127side, 38deck, 254turret; 1x2-381/12 |
| | | 8 | | Mahopac | 1864 | | |
| | | 9 | | Manhattan | 1864 | | |
| | Amphitrite | 10 | M2 | Amphitrite | 1895 | | 3990t, 80.1(10)-79.9(11)-80.2(12,13)x16.9x4.4(10-12)-4.5(13)m, 4b,2hce(10)-4b,2hte(11)-6b,2hce(12,13), 1600(10,12,13)-3000(11)hp, 12(10,12,13)-14.5(11)kts, 150-191p; steel, iron: 229(10,11)-178(12,13)belt, 44deck, 190(10,11)-292(12,13)turrets, 190(10-12)-229(13)CT; 2x2-254/31(10-12), 1x2-254/35(13), 1x2-254/31(13), 2x1-102/40(10,11), 2x1-57/40, 2x5-37/20 |
| | | 11 | M3 | Monadnock | 1896 | | |
| | | 12 | M4 | Terror | 1896 | | |
| 13 | | M5 | Miantonomoh | 1891 | | | |
| Monterey | 1 | 14 | M6 | Monterey | 1893 | | 4084t, 79.5x18.0x4.5m, 4b,2vte, 5250hp, 13.6kts, 218p; Harvey: 330belt, 64deck, 203turrets, 254CT; 1x2-305/35, 1x2-254/31, 6x1-57/40 |
| Puritan | 1 | 15 | M1 | Puritan (TS) | 1896 | | 6060t, 90.3x18.3x5.5m, 8b,2hce, 3700hp, 12.4kts, 200p; Harvey: 356belt, 51deck, 203turrets, 254CT; 2x2-305/35, 6x1-102/40, 6x1-57/40 |

CRUISERS

| | | | | | | | | |
|--|----------|---|---|------|----------|------|--|--|
| | New York | 1 | 1 | ACR2 | New York | 1893 | | 9021t, 117.0x19.8x7.3m, 8b,2vte, 16000hp, 20kts, 566p; nickel steel: 102belt, 152deck, 140gunhouses, 190CT; (2x2+2x1)-203/37, 12x1-102/40, 8x1-57/45, 4x1-37/40, 3-356TT |
|--|----------|---|---|------|----------|------|--|--|

| | | | | | | | | | |
|-----|-------------|------------|----|-----|-------------|----------|--|---|---|
| | Newark | 1 | 11 | C1 | Newark | 1891 |  | 76slopes, 51deck, 76CT; 12x1-152/30, 4x1-57/40, 4x1-47/40, 2x1-37/20 | |
| | Montgomery | 3 | 12 | C9 | Montgomery | 1894 |  | 2235t, 82.1x11.3x4.4m, 6b,2vte, 5400hp, 17kts, 274p; steel: 13slopes, 13deck, 51CT; 9x1-127/40, 6x1-57/45, 2x1-37/40 | |
| | | | 13 | C10 | Detroit | 1893 | | | |
| | | | 14 | C11 | Marblehead | 1894 | | | |
| | Cincinnati | 2 | 15 | C7 | Cincinnati | 1894 |  | 3339t, 93.2x12.8x5.5m, 6b,2vte, 10000hp, 19kts, 322p; steel: 64slopes, 25deck, 102shields, 51CT; 1x1-152/41, 10x1-127/40, 8x1-57/45, 2x1-37/40(15), 4x1-37/40(16), 4-450TT | |
| | | | 16 | C8 | Raleigh | 1894 | | | |
| | Columbia | 2 | 17 | C12 | Columbia | 1894 |  | 8270t, 125.9x17.7x6.9m, 8b,3vte, 21000hp, 21kts, 477p; steel: 102slopes, 64deck, 102casemates, 127CT; 1x1-203/40, 2x1-152/40, 8x1-102/40, 12x1-57/45, 4x1-37/40, 4-450TT(18), 4-356TT(17) | |
| | | | 18 | C13 | Minneapolis | 1894 | | | |
| | Olympia | 1 | 19 | C6 | Olympia | 1895 |  | 6558t, 104.9x16.2x6.6m, 6b,2vte, 13500hp, 20kts, 447p; Harvey: 121slopes, 51deck, 89turrets, 127CT; 2x2-203/37, 10x1-127/40, 14x1-57/45, 6x1-37/40, 6-450TT | |
| | New Orleans | 1 | 20 | | New Orleans | 1898 |  | 4011t, 108.0x13.3x5.5m, 4b,2vte, 7500hp, 20kts, 366p; 89slopes, 32deck, 102CT; 6x1-152/50, 4x1-120/50, 10x1-57/40, 8x1-37/20, 3-450TT | |
| SL | Alert | 2 | 1 | | Alert | 1875 |  | 1020t, 53.3ppx9.8x3.9m, 5b,1hcrccr, 380hp, 10kts, 148p; 1x1-279/15(1), 2x1-229/15(1), 1x1-135/21, 4x1-37/20(1) | |
| | | | | 2 | | Ranger | | | 1876 |
| | | Enterprise | 3 | 3 | | Adams | 1876 |  | 1375t, 56.4ppx10.7x4.4m, 8b,1hcrccr, 700-800hp, 10-11kts, 178-193p; 4x1-229/15, 1x1-203/18, 1x1-135/21, 4x1-37/20 |
| | 4 | | | | Alliance | 1877 | | | |
| | 5 | | | | Essex (TS) | 1876 | | | |
| AMC | | 7 | 1 | | Badger | 1889 |  | 4784t, 100.5x12.8x5.6m, 1vte, 3200hp, 16kts; 6x1-127/40, 6x1-47/40 | |
| | | | | 2 | | Buffalo | 1892 |  | 6888t, 123.8x14.7x6.7m, 1vte, 3600hp, 14.5kts; 2x1-127/40, 4x1-102/40, 6x1-57/40 |
| | | | | 3 | | Dixie | 1893 |  | 6114t, 119.3x14.7x6.1m, 1vte, 3800hp, 16kts; 10x1-152/30, 6x1-57/40 |
| | | | | 4 | | Panther | 1889 |  | 4260t, 98.9x12.3x5.6m, 1vte, 3200hp, 13kts; 6x1-127/40, 2x1-102/40, 6x1-47/40 |
| | | | | 5 | | Prairie | 1890 |  | 6872t, 123.4x14.7x6.7m, 1vte, 3800hp, 14.5kts; 10x1-152/30, 6x1-57/40 |
| | | | | 6 | | Yankee | 1892 |  | 6888t, 123.8x14.7x6.7m, 1vte, 3800hp, 14.5kts; 10x1-127/40, 6x1-57/40 |
| | | | | 7 | | Yosemite | 1892 |  | 6179t, 119.3x14.7x6.1m, 1vte, 3800hp, 16kts; 10x1-127/40, 6x1-57/40 |

TORPEDO SHIPS





| | | | | | | | | |
|-------|-----------|----|--------|----------|------------------|-----------|--|---|
| DD | Farragut | 1 | 1 | TB11 | Farragut | 1899 | | 279t, 65.2x6.3x1.8m, 3b,2vte, 5878hp, 30kts, 66p; 4x1-57/50, 2x1-450TT |
| TB | Stiletto | 1 | 1 | WTB1 | Stiletto | 1887 | No picture | 31t, 28.6x3.5x0.9m, 1b,1vc, 359hp, 18.2kts, 6p; 2Howel torps |
| | Cushing | 1 | 2 | TB1 | Cushing | 1890 | | 116t, 42.7x4.6x1.5m, 2b,2vqe, 1600hp, 23kts, 22p; 3x1-57/40, (1+2x1)-450TT |
| | Ericsson | 1 | 3 | TB2 | Ericsson | 1897 | | 120t, 45.6x4.7x1.5m, 2b,2vqe, 1800hp, 24kts, 22p; 4x1-37/40, (1+2x1)-450TT |
| | Foote | 3 | 4 | TB3 | Foote | 1897 | | 142t, 48.8x4.9x1.5m, 2b,2vte, 2000hp, 25kts, 20p; 3x1-37/40, 3x1-450TT |
| | | | 5 | TB4 | Rodgers | 1898 | | |
| | | | 6 | TB5 | Winslow | 1897 | | |
| | Porter | 2 | 7 | TB6 | Porter | 1897 | | 165t, 53.5x5.4x1.4m, 3b,2vqe, 3200hp, 27.5kts, 24p; 4x1-37/40, 3x1-450TT |
| | | | 8 | TB7 | DuPont | 1897 | | |
| | Morris | 1 | 9 | TB14 | Morris | 1898 | | 105t, 42.5x4.7x1.2m, 2b,2vte, 1750hp, 23kts, 26p; 3x1-37/40, 3x1-450TT |
| | Talbot | 2 | 10, 11 | TB15, 16 | Talbot, Gwin | 1898 | No picture | 46t, 30.5x3.8x1.0m, 1b,1vte, 850hp, 20kts, 12p; 1x1-37/40, 2x1-450TT |
| | MacKenzie | 2 | 12, 13 | TB17, 18 | MacKenzie, McKee | 1898-1899 | No picture | 65t, 30.9x3.9x1.3m, 2b,1vte, 850hp, 20kts, 12p; 1x1-37/40(13), 2x1-37/40(14), 2x1-450TT |
| | Somers | 1 | 14 | TB22 | Somers | 1898 | No picture | 143t, 47.6x5.3x1.8m, 1b,1vqe, 1700hp, 23kts, 24p; 4x1-37/40, (1+2x1)-450TT |
| Rowan | 1 | 15 | TB8 | Rowan | 1899 | | 182t, 51.8x5.2x1.8m, 3b,2vqe, 3200hp, 26kts, 24p; 4x1-37/40, 3x1-450TT | |
| Davis | 2 | 16 | TB12 | Davis | 1899 | | 155t, 45.1x4.7x1.8m, 2b,2vte, 1750hp, 23kts, 24p; 3x1-37/40, 3x1-450TT | |
| | | 17 | TB13 | Fox | 1899 | | | |

ESCORTS

| | | | | | | |
|----|---|---|---|------------|------|--|
| AY | - | 9 | 1 | Mayflower | 1896 | 2690t, 83.2x11.0x5.3m, 2vte, 4700hp, 16.8kts; 2x1-127/40, 12x1-57/40 |
| | | | 2 | Dorothea | 1897 | 594t |
| | | | 3 | Eagle | 1890 | 850t |
| | | | 4 | Gloucester | 1891 | 786t |
| | | | 5 | Hawk | 1891 | 545t |
| | | | 6 | Hornet | 1890 | 425t |
| | | | 7 | Scorpion | 1896 | 850t |
| | | | 8 | Vixen | 1896 | 806t |
| | | | 9 | Wasp | 1898 | 630t |

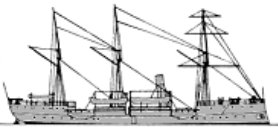
OTHER FIGHTING SHIPS

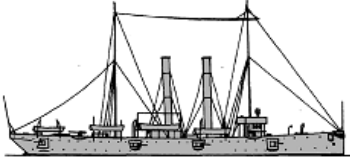
| | | | | | | | | |
|---|----------|---|-----|------------|----------|------|--|---|
| | Michigan | 1 | 1 | | Michigan | 1844 | | 686t, 49.5ppx8.2x3.7m, 1b,1dse(sw), 110hp, 12kts, 148p; 6x1-47/40 |
| | Mohongo | 1 | 2 | | Monocacy | 1866 | | 1370t, 77.7wlx10.7x2.7m, 2b,1hda(sw), 850hp, 12kts, 190p; 4x1-203/14, 2x1-135/21, 4x1-47/40, 4x1-37/20 |
| | Dolphin | 1 | 3 | | Dolphin | 1884 | | 1486t, 78.2x9.8x4.4m, 4b,1vc, 2255hp, 16kts, 152p; 1x1-152/30, 2x1-57/40, 4x5-37/20 |
| | Yorktown | 3 | 4 | PG1 | Yorktown | 1889 | | 1921t, 74.5x11.0x4.3m, 4b,2hte, 3400hp, 16kts, 187-201p; 51CT; 6x1-152/30(4), 6x1-152/35(5,6), 2x1-57/40(4,5), 4x1-57/40(6), 2x1-47/40(4,5), 2x1-37/40(4,5), 4x1-37/40(6) |
| 5 | | | PG3 | Concord | 1889 | | | |
| 6 | | | PG4 | Bennington | 1891 | | | |

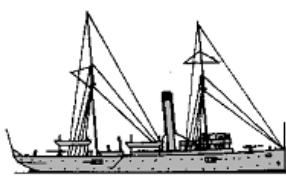
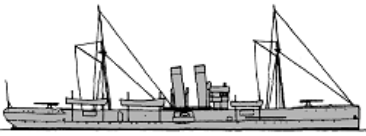
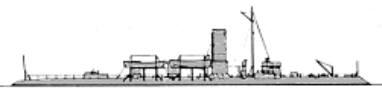
| | | | | | | | | |
|----------|------------|----|----|------------|------------|------------|--|--|
| PG | Petrel | 1 | 7 | PG2 | Petrel | 1889 |  | 867t, 57.3x9.4x3.5m, 4b,1hce, 1000hp, 11.4kts, 138p; 4x1-152/35, 2x1-47/40, 1x1-37/40, 2x5-37/20 |
| | Bancroft | 1 | 8 | | Bancroft | 1893 | No picture | 839t, 57.6x9.8x3.7m, 2b,2vte, 1200hp, 14.5kts, 148p; 4x1-102/40, 8x1-47/40, 1x1-37/40 |
| | Machias | 2 | 9 | PG5 | Machias | 1893 |  | 1318t, 62.2x9.8x3.7m, 2b,2vte, 1900hp, 15.5kts, 154p; 8x1-102/40, 4x1-57/50(9), 6x1-57/50(10), 4x1-37/40 |
| | | | 10 | PG6 | Castine | 1894 | | |
| | Nashville | 1 | 11 | PG7 | Nashville | 1897 |  | 1719t, 71.2x11.6x3.4m, 2b,2vqe, 2530hp, 16.3kts, 180p; 64sponsons; 8x1-102/40, 4x1-57/50, 2x1-37/40 |
| | Wilmington | 2 | 12 | PG8 | Wilmington | 1897 |  | 1689t, 76.4x12.5x2.7m, 6b,2vte, 1900hp, 15kts, 183-199p; 25belt, 38deck, 8x1-102/40, 4x1-57/50, 4x1-37/40 |
| | | | 13 | PG9 | Helena | 1897 | | |
| | Annapolis | 4 | 14 | PG10 | Annapolis | 1897 | No picture | 1000-1153t, 62.3x11.0x3.7-3.9m, 2b,1vte, 1000hp, 11-13kts, 135-156p; 6x1-102/40, 4x1-57/50, 2x1-37/40 |
| | | | 15 | PG11 | Vicksburgh | 1897 | | |
| | | | 16 | PG12 | Newport | 1897 | | |
| | | | 17 | PG13 | Princeton | 1898 | | |
| | Wheeling | 2 | 18 | PG14 | Wheeling | 1897 |  | 1170t, 57.8x10.4x3.7m, 2b,2vte, 1050hp, 13kts, 140p; 6x1-102/40, 4x1-57/50, 2x1-37/40 |
| | | | 19 | PG15 | Marietta | 1897 | | |
| | Alvorado | 2 | 20 | | Alvorado | 1895 | No picture | 106t, 33.6x4.7x1.6m, 1b,1vc, 137hp, 12kts, 33p; 1x1-57/50(20), 2x1-47/45(21), 1x1-37/40(20) |
| | | | 21 | | Sandoval | 1895 | | |
| | Callao | 4 | 22 | PG37 | Callao | 1889 | No picture | 243t, 34.8x5.3x2.0m, 1b,2vc, 275hp, 10-10.5kts, 35p; 1x1-57/50(23-25), 4x1-47/45(22), 3x1-47/45(23,24), 1x1-47/45(25), 2x1-37/40(22,24,25) |
| | | | 23 | PG39 | Pampanga | 1889 | | |
| | | | 24 | | Paragua | 1889 | | |
| | | | 25 | PG41 | Samar | 1888 | | |
| Albay | 2 | 26 | | Albay | 1886 | No picture | 173t, 30.0x5.0x2.2m, 1b,2vc, 150(26)-120(27)hp, 9(26)-7.5(27)kts, 35p; 1x1-57/50(26), 1x1-47/45(27), 2x1-37/40 | |
| | | 27 | | Calamianes | 1888 | | | |
| Manileno | 4 | 28 | | Manileno | 1885 | No picture | 1x1-57/50(28,31), 1x1-47/45(29,30), 2x1-37/40(28,29,31), 1x1-37/40(30) | |
| | | 29 | | Mariveles | 1886 | | | |
| | | 30 | | Mindoro | 1886 | | | |
| | | 31 | | Panay | 1886 | | | |
| APG | - | 1 | 1 | PG35 | Topeka | 1881 |  | 2372t, 76.2x10.7x5.4m, 4b,2hce, 2200hp, 16kts; 8x1-102/40, 2x1-57/50, 4x1-47/45, 2x1-37/40 |
| RAM | Katahdin | 1 | 1 | | Katahdin | 1896 |  | 2383t, 76.4wlx13.2x4.6m, 3b,2hte, 5068hp, 16kts, 97p; Harvey: 152side, 152deck, 457CT; 4x1-57/45 |

COAST GUARD CUTTERS

| | | | | | | | |
|---------------|---|---|--|---------------|------|------------|--|
| Grant | 1 | 1 | | U. S. Grant | 1872 | No picture | 350t, 49.7x7.6x3.5m, 1b,1vte, 45p; 4x1- |
| Manhattan | 1 | 2 | | Manhattan | 1873 | No picture | 147t, 31.1x6.2x2.6m, 1vce, 16p; 1x1-57/40 |
| Dallas | 3 | 3 | | Dallas | 1874 | No picture | 188(3,4)-300(5)t, 42.7(3,4)-53.4(5)x6.5(3,4)-7.9(5)x3.3(3,4)-3.8(5)m, 1b,1seidae(3,4)-1b,1vce(5), 275(3,4)-400(5)hp, 9.5kts, 40p; 2x1-57/40(3,4), 3x1-57/40(5) |
| | | 4 | | Dexter | 1874 | | |
| | | 5 | | Rush | 1874 | | |
| Thomas Corwin | 1 | 6 | | Thomas Corwin | 1877 | No picture | 227t, 42.8x7.3x3.3m, 1b,1seidae, 41p; 3x1- |
| Walter | 1 | 7 | | Walter | 1882 | No | 267t, 47.3x7.6x2.3m, 2vce, 38p; 2x1- |

| | | | | | | | | |
|-----------|-----------------|----|-----------|-----------------|------------|---|--|--|
| CGC | Forward | | | Forward | | picture | | |
| | Fessenden | 1 | 8 | Fessenden | 1883 | No picture | 330t, 58.5x8.5x2.4m, 1vce(sw), 40p; 4x1- | |
| | Commodore Perry | 1 | 9 | Commodore Perry | 1884 | No picture | 282t, 50.3x7.6x3.4m, 1hdase, 41p; 2x1- | |
| | Bear | 1 | 10 | Bear | 1874 | No picture | 703t, 60.5x9.2x5.5m, 1b,1vce, 51p; 3x1-57/40 | |
| | Lot M. Morrill | 1 | 11 | Lot M. Morrill | 1889 | No picture | 288t, 44.3x7.3x2.9m, 1b,1vce, 13kts, 38p; 1x1-76/50, 2x1-57/40 | |
| | Winona | 1 | 12 | Winona | 1890 | No picture | 321t, 45.3x8.0x1.8m, 2vce, 600hp, 39p; 1x1- | |
| | Galveston | 1 | 13 | Galveston | 1891 | No picture | 708t, 57.9x8.8x2.8m, 2b,2vce, 1200hp, 12kts, 41p; 4x1-57/40 | |
| | William Windom | 1 | 14 | William Windom | 1896 | No picture | 670t, 52.0x8.2x2.9m, 2b,2vte, 800hp, 15kts, 49p; 3x1-47/40 | |
| | Gresham | 4 | 15 | CG1 | Gresham | 1897 | No picture | 1190t, 62.6x9.8x3.4m, 4b,1vte, 2500hp, 17kts, 73p; 4x1-57/40 |
| | | | 16 | CG2 | Manning | 1898 | | |
| | | | 17 | CG4 | Algonquin | 1898 | | |
| | | | 18 | CG5 | Onondaga | 1898 | | |
| McCulloch | 1 | 19 | McCulloch | 1897 | No picture | 1280t, 66.8x10.2x4.3m, 2b,1vte, 17kts, 130p; 4x1-76/50, 1-450TT | | |
| Thetis | 1 | 20 | Thetis | 1881 | No picture | 1250t, 57.5x8.9x5.4m, 1vce; 3x1-47/40 | | |



«ШИБА» ведущая больница Израиля
 Инновационные технологии лечения
 ДЛЯ СВЯЗИ >>>

[home](#)[World navies yesterday](#)[1900](#)

Uruguay 01 January 1900

OTHER FIGHTING SHIPS

| | | | | | | | |
|-----|-----------------|---|---|-----------------|------|------------|---|
| PG | General Artigas | 1 | 1 | General Artigas | 1883 | No picture | 270t, 39.0x6.3x2.6m, 1hc, 520hp, 12.5kts; 2x1-120/27 |
| | General Rivera | 1 | 2 | General Rivera | 1884 | No picture | 300t, 35.9x6.3m, 360hp, 12kts, 75p; 1x1-149/27, 1x1-57/27 |
| | Malvinas | 1 | 3 | Malvinas | 1885 | No picture | 400t, 43.0x7.0x3.1m, 280hp, 8kts; 2x1-small guns |
| | General Suárez | 1 | 4 | General Suárez | 1864 | No picture | 405t, 38.8x6.7x3.0m, 205hp, 9kts, 62p; 4x1-79/27 |
| PGR | Maldonado | 1 | 1 | Maldonado | 1886 | No picture | 300t, (stw), 12kts; 4x1-small guns |

© Ivan Gogin, 2015

[home](#)

[World navies yesterday](#)

[1900](#)

Venezuela 01 January 1900

TORPEDO SHIPS

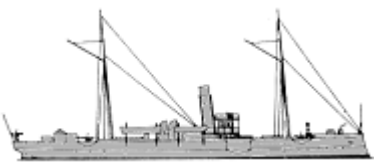
| | | | | | | | |
|-----|---------|---|---|---------|------|---|--|
| PGT | Bolívar | 1 | 1 | Bolívar | 1894 |  | 630t, 58.0ppx6.7x3.2m, 4b,2vte, 2600hp, 19kts, 91p; steel- 13deck; 2x1-120/35, 4x1-57/42, 1x4-25/42, 2x1-356TT |
|-----|---------|---|---|---------|------|---|--|

OTHER FIGHTING SHIPS

| | | | | | | | |
|----|---------|---|---|---------|------|------------|--|
| PG | Miranda | 1 | 1 | Miranda | 1895 | No picture | 200t, 41.5x5.8x2.5m, 1b,1vte, 315hp, 10kts, 55p; 4x1-57/42 |
|----|---------|---|---|---------|------|------------|--|

© Ivan Gogin, 2015