

# High Capacity Metro Trains Project

Project Summary – February 2017





---

# Foreword

On 21 November 2016, the Victorian Government entered into a Public Private Partnership (PPP) with Evolution Rail Pty Ltd (Project Co) to deliver the High Capacity Metro Trains Project (the Project). The Project will be procured and delivered as an ‘availability-based’ PPP.

Under this model, Project Co will be responsible for the design, construction, maintenance and financing of 65 High Capacity Metro Trains (HCMTs) and a range of ancillary activities to support the maintenance and operation of the HCMTs.

This Project Summary provides information about the contractual and commercial aspects of the Project. The document is divided into three parts. The first part is an overview of the Project, including the rationale for PPP delivery, and summarises:

- the tender process
- the value for money calculation
- the public interest considerations for the Project
- the Project timetable.

The second part details the key commercial features of the Project, including the main parties and their general obligations. The third part sets out the broad allocation of risk between the public and private sectors and the treatment of various key Project issues.

Partnerships Victoria forms part of the Victorian Government’s strategy for providing better services to all Victorians by expanding and improving Victoria’s public infrastructure and service delivery. The Partnerships Victoria framework uses private sector expertise to design, finance, build, operate and maintain infrastructure projects. The framework consists of the National Public Private Partnership Policy and Guidelines and supplementary Partnerships Victoria Requirements. Further information on the Partnerships Victoria framework is available at [www.dtf.vic.gov.au](http://www.dtf.vic.gov.au).

This summary should not be relied upon to completely describe the rights and obligations of the parties in respect of the Project, which are governed by the Project Agreement and associated documents. The Project Agreement and associated documents are available online at [www.tenders.vic.gov.au](http://www.tenders.vic.gov.au).

# Contents

<b>Foreword</b>	<b>1</b>
<b>1 Project overview</b>	<b>4</b>
1.1 The HCMT Project	4
1.2 A Public Private Partnership	7
1.3 Tender process	7
1.4 Tender process outcomes	9
1.5 Public interest considerations	10
1.6 Contract milestones	10
1.7 Project advisors	11
<b>2 Financial outcome</b>	<b>12</b>
2.1 Value for money	12
2.2 Additional benefits	13
2.5 State contributions	16
2.6 Proposal cost reimbursement	18
<b>3 Key commercial features</b>	<b>19</b>
3.1 Parties to the contract	19
3.2 Contractual relationships	20
3.3 Risk allocation	21
3.4 General obligations of Project Co	25
3.5 General obligations of the State	25
3.6 Other changes in cost to the State	25
3.7 Default, step-in and termination regime	26
3.8 Finance and security arrangements	28
3.9 Audit and inspection rights of the State	28
3.10 Process for government modification of services/facility	28
3.11 State rights at expiry of contract	28
<b>Appendix 1: Glossary</b>	<b>29</b>
<b>Appendix 2: Useful references/links</b>	<b>30</b>
<b>Appendix 3: Key contact details</b>	<b>31</b>
<b>Appendix 4: Evaluation Criteria</b>	<b>32</b>
<b>Appendix 5: Public Interest Test</b>	<b>34</b>



Dakenham

PT >

# 1 Project overview

## 1.1 THE HCMT PROJECT

### 1.1.1 Overview

The Project requires Project Co to deliver 65 High Capacity Metro Trains (HCMTs) and a range of ancillary activities to support the maintenance and operation of the HCMTs.

The new trains will initially provide a dedicated Fleet for the Cranbourne–Pakenham line (37 HCMTs) which will extend to a dedicated Fleet for the Cranbourne–Pakenham to Sunbury corridor (65) following the opening of the Metro Tunnel. The Project will boost capacity across the metropolitan rail network through the redeployment of existing trains to other parts of the network. The Project includes a new train depot in Pakenham East (including a train maintenance facility and stabling yard), and a light service facility (LSF) in Calder Park to enable the efficient whole-of-asset-life maintenance of the HCMTs. This will provide the necessary flexibility to cater to the future needs of the network.

The Project will create new jobs in Victoria and create new opportunities for the local industry, with the Project including a minimum of 60 per cent local content for each train. The Project will ease congestion and reduce travel times for the one million people living in Melbourne’s south-east corridor.

This Project, when combined with other upgrades on the corridor, will boost capacity on the Cranbourne–Pakenham line – accommodating 11,000 extra passengers in the morning peak.

These upgrades will transform Melbourne’s busiest train line and will support the State’s objective of delivering a world-class public transport network.



Artist’s impression of the HCMT

## 1.1.2 Project objectives

### Project objectives

Provide and maintain 65 safe and reliable trains of at least 1380 gross train capacity (1100 passenger 'planning load' capacity) using a proven platform that provides for a high level of customer amenity and improved service quality standards.

Create local jobs, training opportunities and investment in Victoria.

Achieve at least 50 per cent local content (in accordance with Victorian Industry Participation Policy (VIPPP) requirements) for trains to enable local companies to invest in facilities, new technology and in workers, sustaining local high-skill manufacturing.

Construct and operate a modern, efficient, best practice maintenance facility.

Achieve value for money outcomes for the State.

Ensure the timely provision of trains, effectively and efficiently integrated with the State's Level Crossing Removal Project, the Metro Tunnel and other rail network upgrades.

## 1.1.3 Overview of Project scope

Project Co will be responsible for undertaking the delivery activities and maintenance activities to meet the Project requirements, including:

- design, manufacture and commissioning of 65 HCMTs
- design, construction and commissioning of the depot, the LSF and two simulators
- the transfer of the Pakenham East stabling yard (the returned rail assets) to the State upon the achievement of provisional acceptance of the depot
- maintenance of the Fleet, train maintenance facility (TMF), the LSF, and the simulators
- operation of the TMF, the LSF and the simulators
- provision of HCMTs to the Franchisee
- provision of private sector finance required for the Project
- provision of an option for the purchase of a further 35 HCMTs.

## 1.1.4 Service need

Melbourne's population is forecast to increase to 6 million by 2031. The State has undertaken detailed modelling, which shows that based on this population growth, overall public transport usage is expected to increase strongly in the years ahead. This modelling suggests that from 2011 to 2031:

- weekday patronage across all trains, trams and buses will more than double from 1.8 million to 3.8 million boardings
- annual patronage across all trains, trams and buses is forecast to grow from 517 million to more than one billion boardings
- on metropolitan rail, average weekday boardings are expected to more than double to 1.7 million
- the annual average growth rate in weekday rail boardings is forecast to be around four per cent per annum – an increase of more than 850,000 boardings per day between 2011 and 2031.

Patronage growth is likely to be strongest along those corridors that serve Melbourne's key growth areas, which include the Dandenong, Werribee, Watergardens/Sunbury, Craigieburn, Upfield, and South Morang lines. There is a pressing need to plan for significant improvements to capacity in these corridors, to meet the overall growth in demand.

# 1 Project overview

## The Cranbourne–Pakenham line

The Cranbourne and Pakenham lines run from Melbourne’s south-eastern suburbs as separate lines to Dandenong and then as a single line into the central business district. The lines service the rapidly expanding population of the Casey–Cardinia growth area and the Monash employment cluster, and accommodates regional services from Traralgon and Bairnsdale. Currently 15 metropolitan trains and two regional services operate on the lines in the morning peak with a similar service provision in the evening peak. Patronage growth from this area is expected to remain strong through the medium to longer term.

## The Sunbury to Cranbourne–Pakenham line

The Metro Tunnel (being delivered by the Melbourne Metro Rail Authority) will increase the capacity, reliability and efficiency of Melbourne’s busiest train lines. The project includes two nine-kilometre rail tunnels as part of a new Sunbury to Cranbourne/Pakenham line. Once the tunnels are open, the new Fleet will service this expanded corridor.

## Customer experience

The State is improving the customer experience of public transport. Not only will the rail network need to cater for significantly more customers, it will need to provide an improved experience to those customers. The Project will positively contribute to improving the customer experience.

The State has defined its target customer experience for the future which is articulated in customer language. For the journey stage of travelling on board, the target experience is: “It was a safe and comfortable journey”. To encourage innovative design options, the State has not been prescriptive about how the HCMT should deliver “a safe and comfortable journey” rather the State has encouraged the Project to address key factors which would lead a customer to feel this way, including:

- cleanliness and maintenance (including removal of graffiti)
- reliable and up-to-date information for and during the journey
- a smooth and quiet ride
- knowing how to get attention or call for help
- pleasant temperature
- less crowding
- comfort when standing and sitting.

In meeting the customer experience expectations, the State seeks an inclusive design, which applies a broad spectrum of ideas to produce a train and customer environment that is accessible to older people, people without disabilities, and people with disabilities.



## 1.2 A PUBLIC PRIVATE PARTNERSHIP

The Project is a Public Private Partnership (PPP) that is being delivered under the Partnerships Victoria framework. The Partnerships Victoria model seeks to achieve better value for money by capturing the expertise and efficiencies of the private sector in designing, financing, building and maintaining infrastructure projects and providing services on a whole-of-life basis.

The Partnerships Victoria framework requires that projects comply with the:

- National PPP Policy and Guidelines that apply across all state, territory and commonwealth arrangements
- requirements specific to Victoria as detailed in the Partnerships Victoria Requirements (updated in November 2016).

Details of the National PPP Guidelines and the Partnerships Victoria Requirements are available at [www.infrastructureaustralia.gov.au](http://www.infrastructureaustralia.gov.au) and [www.dtf.vic.gov.au](http://www.dtf.vic.gov.au) respectively.

## 1.3 TENDER PROCESS

### 1.3.1 Overview

The State conducted a competitive tender process to select a private sector party to deliver the Project. The tender process was implemented in accordance with the Partnerships Victoria framework to ensure that the State received the best value for money outcome. The tender process involved three phases as described below:

- Expressions of Interest (EOI) phase, involving the release of the invitation for EOI and concluding with the selection of the short listed Respondents.
- Request for Proposal (RFP) phase, involving the issue of a RFP to shortlisted Respondents, an intensive interactive tender process, submission of Proposals by Respondents, and a clarification and evaluation of Proposals.
- Negotiation and completion phase, involving a negotiation period, the appointment of a preferred Respondent, final negotiations, the execution of the Project Agreement and the achievement of Contract and Financial Close.

### 1.3.2 Tender process timetable

The tender process for the Project commenced on 26 June 2015 and concluded with the achievement of Financial Close on 24 November 2016. Table 1 below contains a summary of the key dates of the tender process.

**Table 1. Tender process – key dates**

Tender Process Activity	Date
<b>EOI phase</b>	
Invitation for EOI issued	26 June 2015
EOIs received	14 August 2015
Shortlisted Respondents announced	9 November 2015
<b>RFP phase</b>	
RFP issued	27 November 2015
Proposals received	20 May 2016
<b>Negotiation and completion phase</b>	
Preferred Respondent announced	12 September 2016
Contract Close	21 November 2016
Financial Close	24 November 2016

# 1 Project overview

## 1.3.3 Tender process governance structure

The State established a formal evaluation and governance structure to oversee the EOI and RFP evaluation processes. An evaluation panel supported by five discipline-based evaluation sub-panels conducted the EOI and RFP evaluations. The sub-panels comprised the:

- Victorian Industry Participation Policy (VIPP) sub-panel
- Technical sub-panel
- Maintenance sub-panel
- Commercial and legal sub-panel
- Value and risk sub-panel.

The selection of the State’s evaluation panel and evaluation sub-panels was made based on government stakeholder representation (including the Department of Treasury and Finance and Public Transport Victoria) and requirements for appropriate and relevant skills and experience. Specialist advisers and other government agencies supported the evaluation panel as required. The Evaluation Criteria used in the assessment of Proposals are presented in Appendix 4.

The evaluation panel reported to an interdepartmental project steering committee, which included senior representatives of the Department of Economic Development, Jobs, Transport and Resources, Public Transport Victoria, the Department of Treasury and Finance and the Department of Premier and Cabinet.

The evaluation and governance structure is represented in figure 1 below.

Figure 1: Evaluation and governance structure

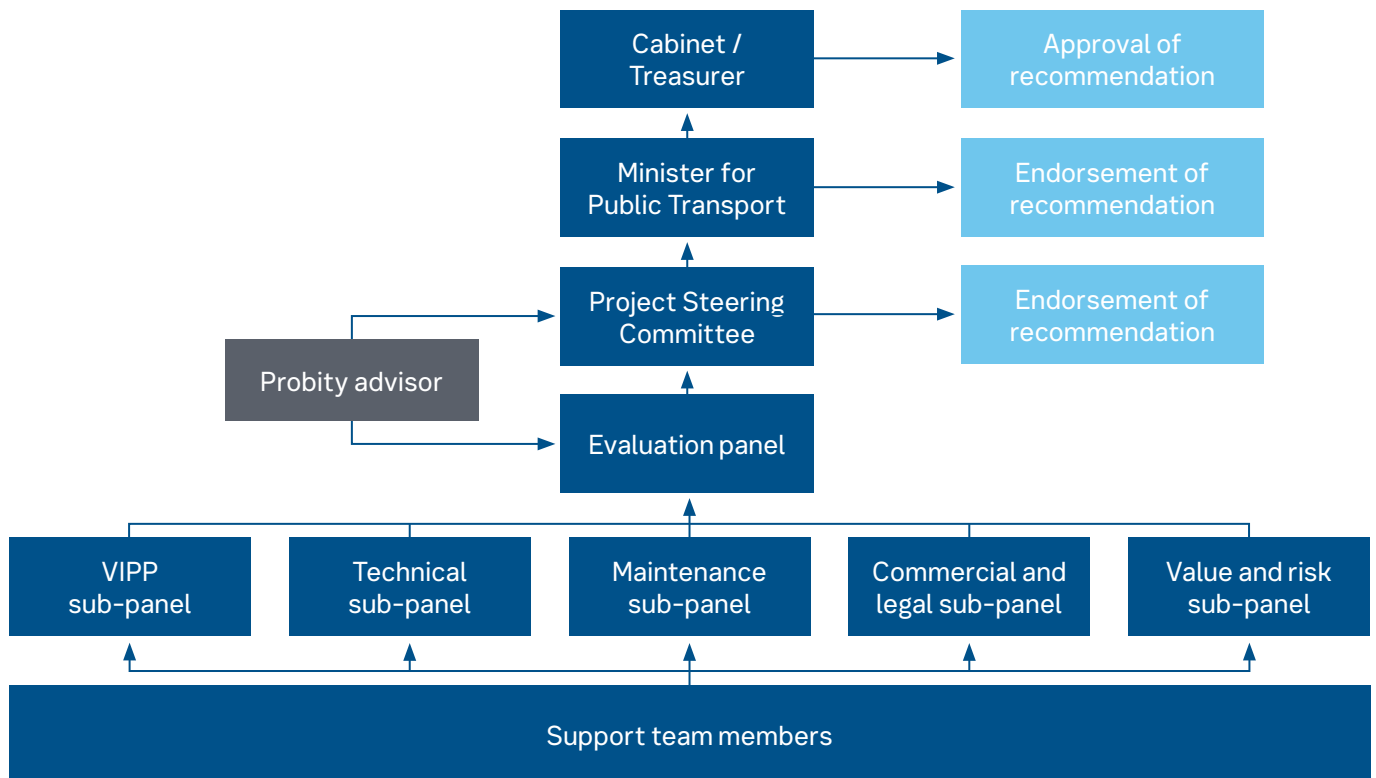

### 1.3.4 Probity

The tender process was undertaken within a robust probity framework developed in consultation with the Project's probity advisor, and was based on the following probity principles:

- Accountability of the participants and transparency of the process.
- Fairness, impartiality and honesty in carrying out the process.
- Management of actual, potential and perceived conflicts of interest.
- Maintenance of confidentiality and security of documentation and information.
- Attaining value for money.

At the completion of the tender process, the probity auditor appointed to oversee the State's compliance with the probity framework concluded that the tender process had been conducted in a manner consistent with the probity principles.

## 1.4 TENDER PROCESS OUTCOMES

Five interested consortia submitted EOIs and three were selected to proceed to the RFP phase. The RFP was issued to the three shortlisted Respondents on 26 June 2015. The State conducted a comprehensive interactive tender process, involving numerous workshops with each Respondent. The shortlisted Respondents submitted their Proposals on 20 May 2016.

Following an extensive evaluation of the Proposals, the State entered into exclusive negotiations with Project Co. After the successful completion of this negotiation period, the State formally announced Project Co as its preferred Respondent. Following this announcement, both parties negotiated the final form of the Project documents and executed the Project Agreement and ancillary contracts that govern the Project on 21 November 2016.

Project Co's offer has been assessed to provide significant value and affordability relative to the Public Sector Comparator (PSC). The Project is on track for completion within the approved timeframes with testing of the first HCMT to commence in November 2018 and revenue services to commence on the Cranbourne-Pakenham corridor in 2019.

Trains in the Fleet will be significantly larger than existing trains operating on the metropolitan network, providing seven cars capable of moving 1380 passengers (measured as gross train capacity). In addition to this, key features of the Fleet include:

- multiple types of passenger seating arrangements
- more convenient and safe areas for passengers to stand
- multiple types of passenger grab handles
- 28 allocated wheelchair spaces, extra-wide aisles and innovative wheelchair ramps
- 6 bicycle storage spaces spread evenly throughout the train
- large windows aligned to the seating arrangement
- wide doors, which are consistently spaced along the length of the train
- advanced passenger information system, supported by 70 passenger information displays per train.

# 1 Project overview

The table below summarises key project outcomes in relation to government policy requirements, and where appropriate indicates the degree to which the Project has exceeded the State’s minimum requirements as contained in the RFP.

Policy	Contracted outcome	Minimum requirement	Difference
<b>Victorian Industry Participation Policy local content target</b>			
Local content (ANZ) – Fleet	60%	50%	+10%
Local content (ANZ) – depot	87%	80%	+7%
Local content (ANZ) – maintenance	82%	NA	NA
<b>Major Projects Skills Guarantee</b>			
Vocational training (delivery phase)	15%	10%	+5%
<b>Other government policy objectives</b>			
Disadvantaged workers (delivery phase)	7%	2.5%	+4.5%

## 1.5 PUBLIC INTEREST CONSIDERATIONS

At various stages throughout the development of the Project, the State made an assessment of the extent to which the Project was in the public interest. The analysis was undertaken in accordance with the Partnerships Victoria guidance on how to evaluate whether a project meets the public interest.

At all stages the State determined that, on balance, the public interest was being protected. Appendix 5 contains the Public Interest Test.

## 1.6 CONTRACT MILESTONES

The government requires the delivery of the first HCMT for testing in November 2018 to enable the commencement of revenue services in 2019. The Project Agreement contains a number of contract milestones for Project Co to meet as summarised in the table below.



Artist’s impression – aerial view of Pakenham depot.

**Table 2: Contract milestone summary**

Contract milestone	Date
Contract Close	21 November 2016
Financial Close	24 November 2016
Provisional acceptance of the depot	14 December 2018
Provisional acceptance of the 1st HCMT (commencement of revenue service)	29 March 2019
Provisional acceptance of the Initial Fleet	2 August 2021
Provisional acceptance of the Fleet	18 July 2023
Provisional acceptance of the Project	18 July 2023
Final acceptance of the Fleet	29 January 2024
Maintenance phase	14 December 2018 to 18 July 2053
Contract expiry date	18 July 2053

\* First train available for testing November 2018.

## 1.7 PROJECT ADVISORS

The following external advisors were engaged to assist the State in undertaking the tender process.

**Table 3: Project advisers**

Role	Organisation
Transaction advisor	Everything Infrastructure Group
Technical advisor	Indec
Legal advisor	Herbert Smith Freehills
Commercial and financial advisor	PwC
Cost consultant	Aquenta
Planning and environment advisor	AECOM
Probity auditor	RSM
Probity advisor	O'Connor Marsden

## 2 Financial outcome

### 2.1 VALUE FOR MONEY

#### 2.1.1 Overview

The Partnerships Victoria framework seeks to identify and implement the most efficient form of infrastructure and service delivery. The concept of value for money goes beyond the selection of the cheapest solution, focusing on the value of each delivery option. This involves an in-depth analysis of each Proposal received from the private sector and comparison against a State-managed delivery option. The analysis considered quantifiable elements (for example, items that can be quantified in monetary terms or as a quantity of volume or throughput) as well as qualitative considerations.

#### 2.1.2 Public Sector Comparator

The Public Sector Comparator (PSC) is an estimate of the hypothetical, risk-adjusted, whole-of-life cost of the project if delivered by the State. The PSC is developed in accordance with the output specification and risk allocation proposed for the private sector party arrangement, and is based on the most likely and efficient form of conventional (that is, non-public private partnership) delivery by the State.

The PSC is expressed in terms of the Net Present Cost (NPC) to the State, calculated using a discounted cash flow method taking full account of the costs and risks that would arise through State delivery. The PSC includes amounts for the design and construction of the HCMTs, depot, LSF and simulators as well as maintenance and lifecycle costs during the maintenance phase of the Project.

The PSC is made up of a number of elements as contained in table 4 below.

**Table 4: Components of the public sector comparator**

Components of the PSC	NPC (\$millions)
Capital costs	1,506.5
Maintenance and lifecycle costs	2,109.0
<b>Raw PSC</b>	<b>3,615.5</b>
Transferred risks	196.6
<b>PSC (excluding retained risk)</b>	<b>3,812.1</b>

Notes to Table 4:

1. All numbers are expressed in net present values as at 30 November 2016
2. In accordance with the national PPP Guidelines, a risk free rate of 2.69 per cent was used in calculating the NPC of the PSC
3. The PSC includes adjustments for 'competitive neutrality' where necessary
4. The PSC excludes State retained risk to enable a like-for-like comparison to be made

#### 2.1.3 Net present cost of Project Co's proposal

The quantitative value for money assessment, as demonstrated by the estimated savings between the PSC and private sector contract cost is shown below in Table 5.

**Table 5: Value-for-money comparison – PSC versus private sector delivery**

Public sector comparator NPC (\$millions)	Project Co contract cost NPC (\$millions)	Estimated savings
3,812.1	2,342.9	38.5%

Notes to Table 5:

1. All non-percentile numbers are expressed in net present values as at 30 November 2016
2. In accordance with the national PPP Guidelines a discount rate of 4.85 per cent (and 4.50 per cent for the State Contribution) was used in calculating the NPC of private sector delivery

## 2.2 ADDITIONAL BENEFITS

In addition to meeting all of the State's requirements for the Project at a price that is 38.5 per cent less than the State's PSC, Project Co's Proposal also contained a number of additional benefits for the State and HCMT users, including the following:

- The local content (ANZ) for the construction of each HCMT will be 60 per cent. This is 10 per cent above the State's minimum requirement and will provide more local jobs and will continue to support a sustainable rolling stock capability in this State.
- Project Co has committed to a workforce development outcome of 15 per cent during the delivery phase of the Project. As such, 15 per cent of Project Co's workforce will be comprised of apprentices and cadets. This is 5 per cent greater than the State's minimum requirement.
- At least 7 per cent of the delivery phase workforce will be comprised of disadvantaged workers. This will provide further opportunities for indigenous Australians, persons with a disability and the long term unemployed to obtain lasting employment in the manufacturing sector.
- The HCMTs will be designed to exceed the State's minimum reliability requirements, resulting in less in-service failures and an overall increase in Fleet reliability and passenger service levels.
- The HCMT design will provide a range of additional train functionality, including:
  - automatic selective door controls to disable the opening of selected doors under certain operating scenarios
  - train operator stopping aids to minimise trains overshooting platforms
  - access cards to provide easier and more secure access to the drivers cabin
  - additional CCTV cameras to enhance security and safety outcomes.

## 2.3 Other costs

In addition to the costs shown above for the PSC and the NPC of Project Co's Proposal, the State will meet a range of other costs in relation to the Project, including:

- State project management costs of administering the Project Agreement
- Project delivery risks retained by the State
- the State's 50 per cent share of Independent Reviewer costs
- land acquisition costs for the depot and LSF
- Information and Communications Technology (ICT) upgrades required to State-side ICT systems to interface with the new Fleet
- supply of digital train radio systems equipment for the Fleet
- provision, installation and fitment of high capacity signalling equipment
- project management, test driver and driver training costs of the Franchisee (the operator of the Melbourne metropolitan network)
- supply of depot signalling equipment at the stabling yard.

## 2.4 Costs and service payments

The payment mechanism for the Project is consistent with the mechanisms developed in precedent 'availability based' rolling stock projects and has been developed to drive performance, innovation and value for money.

Payments to Project Co will be determined in accordance with a defined Quarterly Service Payment (QSP) formula that reflects a traditional payment mechanism alongside an abatement regime.

## 2 Financial outcome

### 2.4.1 Quarterly Service Payments

The table below summarised the key components of the Quarterly Service Payments (QSPs).

#### Key Components of the QSPs

Partial service payment	Partial service payments will be determined by reference to the number of days a HCMT has been commissioned during a quarter against a predefined daily price per HCMT. This payment applies on a per HCMT basis from the commencement of the transition-in-phase (after provisional acceptance of the 5th HCMT) to the start of the maintenance payment phase.
Base service payment	The base service payment will cover fixed debt and equity repayments over the Project term together with other costs not separately captured in the payment formula. This payment will apply during the maintenance payment phase.
Maintenance payment	<p>The maintenance payment reflects:</p> <ul style="list-style-type: none"><li>– general maintenance payments, covering all maintenance, operating and utility costs (excluding electricity)</li><li>– Fleet kilometre payments, representing the variable cost of providing the Fleet on a per kilometre basis, made as an annual adjustment where average Fleet kilometres exceed 150,000km per HCMT</li><li>– electricity volume adjustments, representing an adjustment to the maintenance payment should annual usage of electricity at the TMF exceed the maximum electricity volume.</li></ul> <p>The maintenance payment will be subject to adjustments for escalation and foreign exchange rebases (at years 10 and 20 of the maintenance payment phase).</p>
Additional service payment	An additional service payment made to cover the costs of Project Co providing a HCMT that is above the required availability levels.

### 2.4.2 Abatement regime

Abatements to the QSPs may be made every quarter during the transition-in phase and maintenance payment phase based on Project Co's performance. The abatement regime has been designed to minimise fault attribution with the Franchisee. It will focus on the availability and performance of the HCMTs and not the achievement of the Franchisee's timetable.

The abatement regime consists of three components:

- Reliability and disruption adjustment.
- Key Performance Indicator adjustment.
- Delivery phase adjustments.

#### Reliability and disruption adjustment

The reliability and disruption adjustment is designed to provide a commercial incentive to deliver high levels of availability and reliability of the HCMTs. The structure has been designed to minimise fault attribution between Project Co and the Franchisee and provides a focus on availability and performance of the HCMTs and not performance against the Franchisee's timetable.

The reliability and disruption adjustment adopts a scalable abatement level to reflect various 'unavailability' circumstances, including cancelled HCMTs during service.



### Key Performance Indicator adjustment

The Key Performance Indicator (KPI) adjustments are designed to inform a design solution and to incentivise performance and rectification activities. The KPIs provide performance requirements in the following areas:

- presentation standards (including interior and exterior cleanliness and standards, graffiti and vandalism removal)
- safety performance
- performance and defects
- simulator availability
- reporting.

The KPI regime provides (where relevant) a reasonable period for Project Co to respond to incidents and events and to rectify to the standards required prior to a KPI adjustment applying.

### Delivery phase adjustments

The QSPs will also be subjected to the following one-off adjustments at the end of the delivery phase. These delivery phase adjustments include:

- failure to meet proposed Fleet mass (e.g. the Fleet mass exceeds the proposed Fleet mass resulting in additional electricity usage)
- failure to meet local content requirements for the Fleet
- failure to meet the vocational training requirement
- failure to meet the disadvantaged worker requirement.

### 2.4.3 QSPs and lease treatment

The following tables provide further details on the quantum of the QSPs and the lease treatment for the Project.

**Table 6: Disclosure of nominal flows**

NPC of Proposal as at 11/16 (\$'000s)	Discount rate used to arrive at NPC	Total cost of Proposal (nominal – \$'000s)	First full year QSP payment (nominal – \$'000s)
2,342,901	4.85 per cent and 4.50 per cent for the State contribution	5,686,163	123,452 <sup>1</sup>

Notes to table 6:

1. These are the first four QSPs post the cessation of the Partial Service Payments (PSPs).

**Table 7: Disclosure of lease liability**

Lease liability expected to be recognised at Provisional Acceptance Project (nominal) (\$'000s) <sup>1-4</sup>	Lease liability expected to be recognised at Provisional Acceptance Project (NPC) (\$'000s) <sup>1-4</sup>	Expected year of Provisional Acceptance Project	Implied interest rate in lease liability
2,999,585	1,691,030	2024	4.90%

Notes to Table 7:

1. The lease asset and liability will be recognised progressively up until the achievement of Provisional Acceptance Project.
2. The Pakenham East stabling yard represents an item of property plant and equipment returned to the State upon completion which is not maintained by Project Co throughout the contract term (returned rail assets), and therefore represents a financial liability rather than a lease liability. The financial liability associated with the stabling yard will be paid down by a portion of the first State Contribution that will be paid at Provisional Acceptance of the 37th HCMT.
3. The lease liability is net of State Contributions and PSPs paid up to Provisional Acceptance Project.
4. The lease liability will be further reduced by the second and third State Contributions.

## 2 Financial outcome

**Table 8: Breakdown of Service Payments**

	(Nominal) (\$'000s)
Implied principal payments on lease liability	1,527,589
Implied interest payments on lease liability	1,383,346
Implied operating and maintenance component of QSP	2,353,982
<b>Sum of State QSPs over the term</b>	<b>5,264,917</b>

Notes to table 8:

1. Table 8 provides the breakdown of State Service Payments over the Project Term.

### 2.5 STATE CONTRIBUTIONS

Upon and subject to the achievement of certain contractual milestones over the Project term, Project Co will be entitled to receive State contributions equal to 30 per cent of the debt forecast at Financial Close to be outstanding at provisional acceptance of the Project. Payments will be available in three tranches as described below:

- State contribution 1 will be payable upon the achievement of provisional acceptance of the initial fleet.
- State contribution 2 will be payable upon the achievement of provisional acceptance of the Project.
- State contribution 3 will be payable upon the achievement of final acceptance of the Project.

Whilst a component of debt will be repaid upon payment of each State contribution, the payments will have no material impact on the risk allocation for the Project, as Project Co may still incur significant payment reductions if the services are not delivered to the required standard.

The figure opposite identifies key contractual milestones and the timing for State contributions.

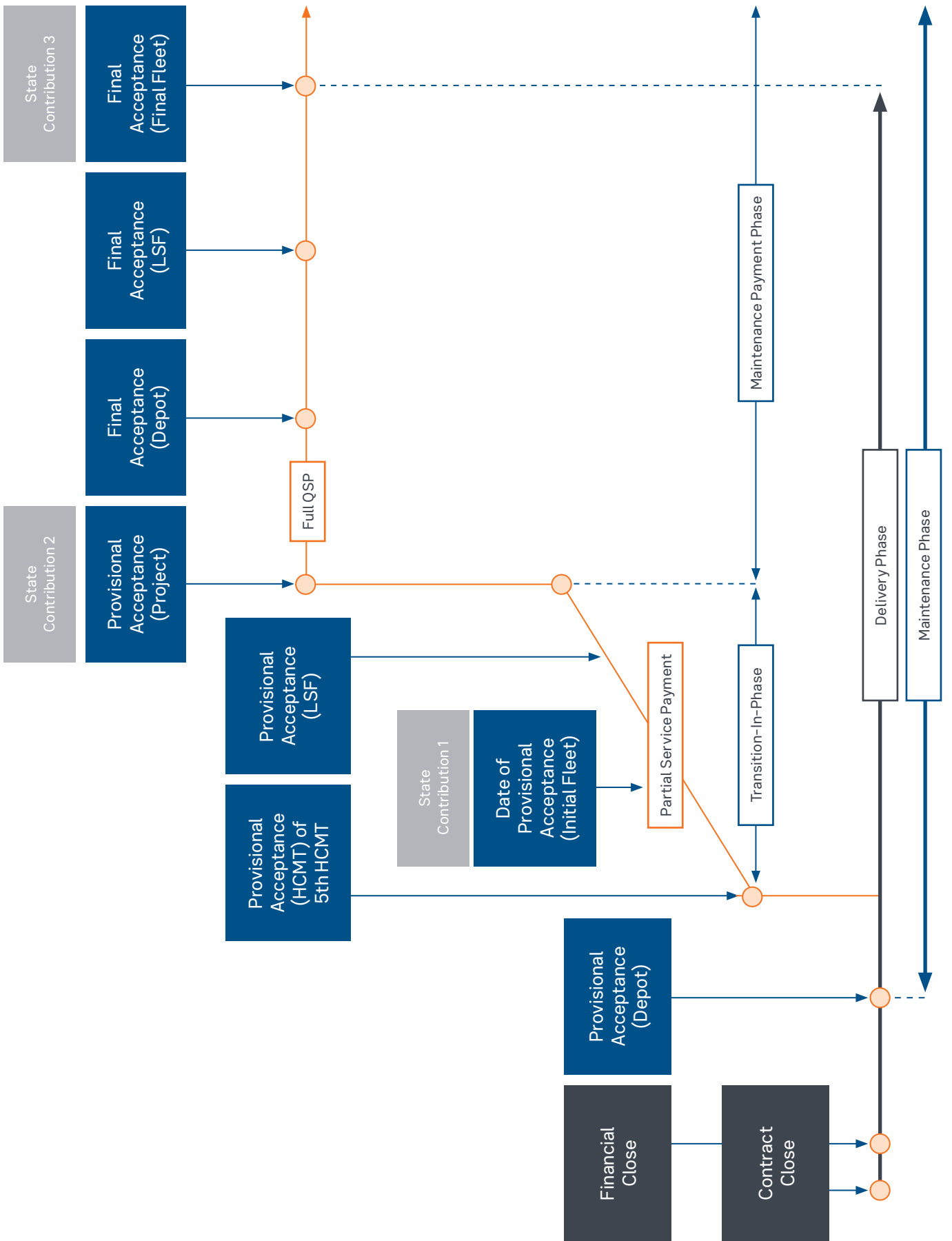

## 2 Financial outcome

### 2.6 PROPOSAL COST REIMBURSEMENT

The State has not contributed to, or directly reimbursed, any private sector costs of preparing Proposals or participating in the tender process more generally.



Artist's impression

## 3 Key commercial features

### 3.1 PARTIES TO THE CONTRACT

The relevant parties under the contractual arrangements are:

Entity	
<b>State parties</b>	
The State	The <b>State</b> is a signatory to the Project Agreement and other relevant ancillary Project documents. The Minister for Public Transport is the person empowered to execute these contracts on behalf of the State.
PTV	The <b>Public Transport Development Authority</b> (a body corporate established under the <i>Transport Integration Act 2010</i> (Vic)) is the entity which will, among other things, licence and lease to Project Co various assets.
<b>Key private sector parties</b>	
Project Co	<b>Evolution Rail Pty Ltd</b> in its personal capacity and in its capacity as trustee for the Evolution Rail Unit Trust is the counterparty to the Project Agreement, and is the primary contracting entity with the State. Evolution Rail Pty Ltd, in turn, has entered into a range of contracts with its consortium partners to deliver elements of the Project. Notwithstanding this, Evolution Rail Pty Ltd will be the organisation ultimately responsible for the delivery of the Project.
HCMT Supplier	Project Co has engaged <b>Downer EDI Rail Pty Ltd</b> and <b>CRRC Changchun Railway Vehicles Co., Ltd</b> under an unincorporated joint venture arrangement to undertake the design and construction of the HCMTs, the simulators, TMF and LSF.
Depot Subcontractor	The HCMT Supplier has engaged <b>Downer EDI Works Pty Ltd</b> to undertake the design and construction of the Depot (including the TMT) and LSF.
CRRC Subcontractor	The HCMT Supplier has engaged <b>CRRC Changchun Australia Pty Limited</b> to undertake the design and construction of the HCMTs.
Maintenance Subcontractor	Project Co has engaged <b>Downer Victoria PPP Maintenance Pty Ltd</b> to undertake the operation, maintenance and repair of various assets.
Equity Investors	The following entities have committed to provide the equity required for Project Co: <ul style="list-style-type: none"> <li>- CRRC Changchun Railway Vehicles Co., Ltd</li> <li>- Downer EDI Associated Investments Pty Ltd</li> <li>- Plenary Investments (HCMT) Pty Ltd</li> <li>- Partners Group Access 816 L.P</li> </ul>
Financiers	The following entities have committed to provide the senior debt required for the Project: <ul style="list-style-type: none"> <li>- Westpac Banking Corporation</li> <li>- Bank of China Ltd</li> <li>- Mizuho Bank Ltd</li> <li>- Intesa Sanpaolo S.p.A</li> <li>- United Overseas Bank Ltd</li> <li>- The Hong Kong and Shanghai Banking Corporation Limited</li> <li>- Industrial and Commercial Bank of China Limited</li> <li>- Bank of Communications Co, Ltd</li> </ul>
<b>Other parties</b>	
Franchisee	The Franchisee for the Melbourne metropolitan rail network is <b>Metro Trains Melbourne Pty Ltd</b> . Metro Trains Melbourne Pty Ltd, as the operator of the Melbourne metropolitan rail network, will coordinate various activities with Project Co.
Independent Reviewer	<b>Mott McDonald Australia Pty Ltd</b> has been jointly appointed by the State and Project Co to oversee the design and construction of the Project in accordance with the Independent Reviewer Deed of Appointment.

### 3 Key commercial features

#### 3.2 CONTRACTUAL RELATIONSHIPS

The relationship between the State, Project Co and other related parties is detailed in the Project Agreement and associated documents. Figure 1 outlines the structure and principal agreements required for implementing the Project.

**Figure 1: Contract arrangements and relationships**

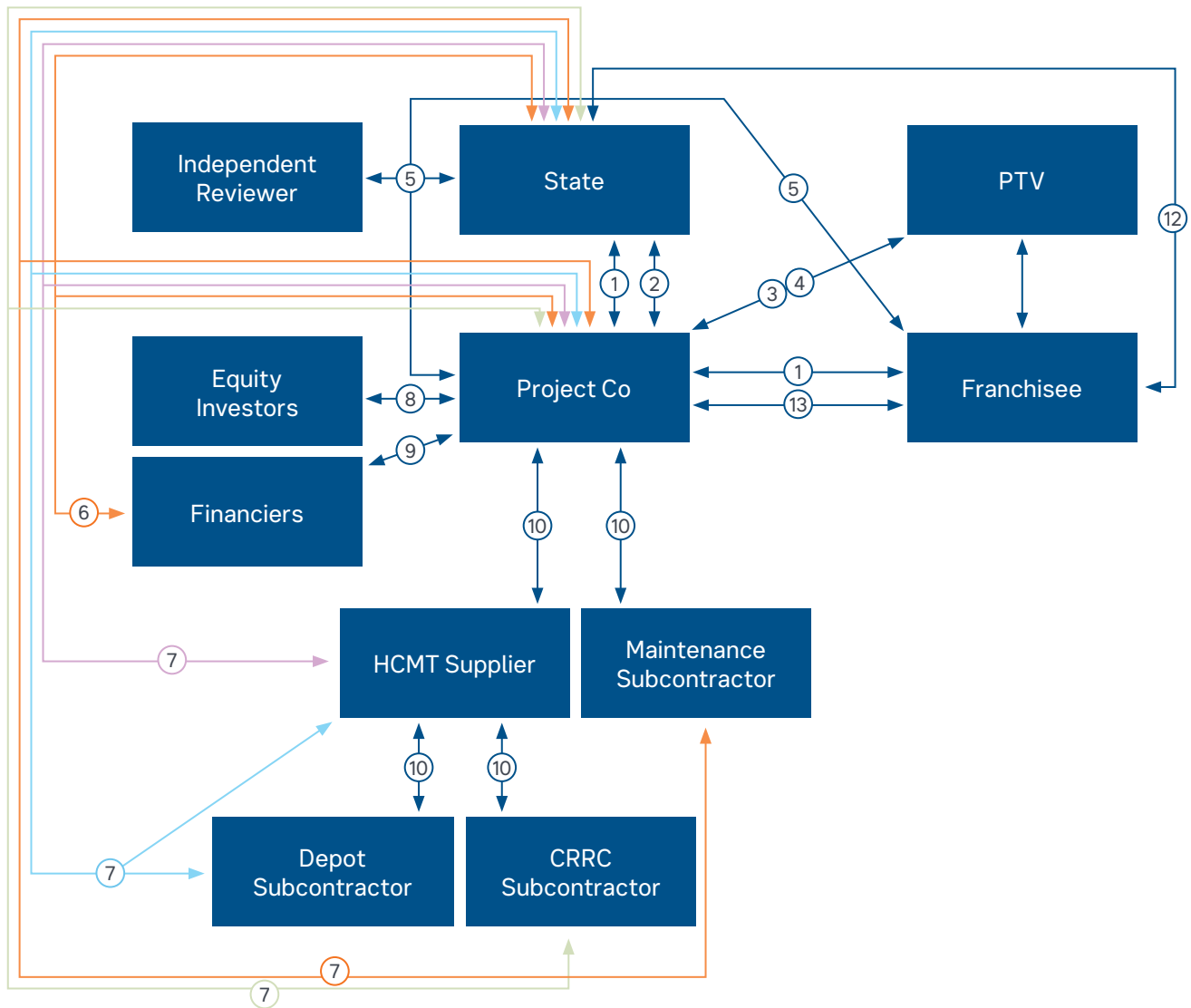

#### Legend

- |   |  |
|---|--|
| 1. Project Agreement                        | 8. Equity Documents                              |
| 2. State Security                           | 9. Finance Documents                             |
| 3. HCMT lease                               | 10. Key Subcontracts                             |
| 4. Licences                                 | 11. Franchisee Cooperation Agreement             |
| 5. Independent Reviewer Deed of Appointment | 12. Franchisee Cooperation Agreement Direct Deed |
| 6. Finance Direct Deed                      | 13. Sub-Licence (Franchisee) and HCMT Licence    |
| 7. Key Subcontractor Direct Deeds           |  |

### 3.3 RISK ALLOCATION

The risk allocation in the Project Agreement allocates risks to the party best able to manage them in order to achieve the best value for money for the State. This results in various risks being:

- retained by the State
- transferred to the private sector
- shared between the parties.

The Project Agreement and associated documents establish the obligations of each party in managing these risks.

Table 9 provides a high level outline of the risk allocation for the Project. Risks that are identified by the symbol **(F)** are shared with the Franchisee. Where a risk is allocated to more than one party, those parties may not share that allocation equally. All risks are dealt with in detail in the Project Agreement and associated documents.

**Table 9: Risk summary**

No.	Type of risk	Description	Allocation		
			State	Shared	Project Co
<b>Site Risks</b>					
1	Land acquisition – for land agreed at Contract Close	Risk of cost and delay associated with acquiring the land identified at Contract Close.	•		
2	Land acquisition – State changes	Risk of cost and delay associated with acquiring land as a result of design changes requested by the State after Contract Close.	•		
3	Additional land	Any additional land required by Project Co above the land made available by the State.			•
4.1	Planning approvals	Obtaining planning approvals for the Project in relation to land made available by the State. Obtaining planning approvals for the Project in relation to any additional land required by Project Co.	•		•
4.2	Planning approvals	Obligation to comply with relevant planning approval conditions.			•
5	Native title claims	Risk of cost and delay if native title claims are made in respect of land made available by the State. Risk of cost and delay if native title claims are made in respect of any additional land required by Project Co.	•		•
6	Aboriginal heritage and artefacts	Risk of cost and delay resulting from discovery of items of Aboriginal heritage and artefacts at the site.		•	
7	Site conditions	Geotechnical, contamination and other site conditions (including services and utilities) in respect of the Project.			• <sup>2</sup>

2. Project Co may be entitled to time and cost relief where a contamination remediation event occurs.

### 3 Key commercial features

No.	Type of risk	Description	Allocation		
			State	Shared	Project Co
<b>Design and build risks</b>					
8	Force majeure	Risk of delay caused by force majeure events which delay dates for acceptance.		•	
9	Access for interface works	Risk of procuring the necessary access to the network to deliver Project. Any required additional access above the access made available as of Contract Close.			• (F) •
10	State initiated variations to the Project scope	Risk of cost and delay where the State requests alterations to the performance specifications.	•		
11	Other State projects	Impact of other State projects which result in a modification or delay to the Project, including: – The Metro Tunnel (including high capacity signalling) – other aspects of the Cranbourne Pakenham Line Upgrade program.	• •		
12	Franchisee interface risk	The interface with the Franchisee during the delivery phase in relation to: – track occupations and track access – design authority – design process – accredited rail operator compliance.			• (F) • (F) • (F) • (F)
13	Design	Design does not meet the Project scope.			•
14	Completion	Delay in achieving any acceptance dates.			• <sup>3</sup>
<b>Operating Risks</b>					
15	Franchisee interface risk	The interface with the Franchisee during the maintenance phase in relation to: – fault attribution – compliance with agreed operational requirements – making HCMTs available – access to stabled HCMTs – accredited rail operator compliance.	•		• • • (F) •
16	Safety and security	Safety and security of the HCMTs.			• (F)
17	Force majeure	Risk that force majeure events affect the operation or availability of HCMTs.		•	
18	Operational interfaces	Management of operational interfaces with the Franchisee.			• (F)
19	Meeting operational and performance requirements	HCMT performance does not meet the operational and performance requirements of the Project.			•

3. Project Co may be entitled to an extension of time where an extension event, contamination remediation event, modification or a change in mandatory requirements occurs, or where the State requires the reinstatement of an asset on the basis of a different specification.



No.	Type of risk	Description	Allocation		
			State	Shared	Project Co
20.1	Graffiti and vandalism risk	Responsibility for graffiti or vandalism within areas managed by Project Co.			•
20.2	Graffiti and vandalism risk	Responsibility for cost and disruptions caused by graffiti or vandalism to HCMTs.		•	
21	Asset availability and maintenance	Making assets available for the Franchisee in accordance with availability requirements and levels.			•
22	Maintenance cost	Cost of maintaining the HCMTs to meet the operational and performance requirements of the Project scope.			•
23	Residual life and end of Project term handover	Satisfying the residual design life requirements for the Fleet and depot and at the end of the maintenance phase.			•
24	Changes in service levels	Changes in service levels and service plan impacting the maintenance and mileage per HCMT: <ul style="list-style-type: none"> <li>- within parameters agreed in the Project Agreement</li> <li>- modification to service levels and service plan outside the agreed parameters.</li> </ul>	•		•
25	Fare box revenue	Risk on the fare box revenue generated by HCMT patronage.	•		
<b>Accreditation</b>					
26.1	Rail safety accreditation	Obtaining and maintaining accreditation for the design and manufacture of the HCMTs and the design and construction of the depot.			•
26.2	Rail safety accreditation	Providing assistance to the Franchisee to vary its accreditation as necessary for operation of the HCMTs.			• (F)
26.3	Rail safety accreditation	Obtaining and maintaining accreditation for passenger operations as rail infrastructure manager and rolling stock manager.			• (F)
<b>Industrial Relations</b>					
27	Industrial relations risk	Risks of industrial action in respect of Project (excluding those actions which directly affect Project Co and which directly result from an act or omission of the State).			•
28	Industrial relations as it relates to train operator HCMT acceptance	The introduction of the Fleet to the network may impact the current arrangements with train operators.			• (F)
<b>Change in Law</b>					
29	Project specific change in law	Risk of additional cost or delay resulting from changes in State policy or law which directly affect the Project.	•		
30	General change in law	Risk of a general change in law (excluding changes in law relating to rail safety).		•	

### 3 Key commercial features

No.	Type of risk	Description	Allocation		
			State	Shared	Project Co
<b>Financing</b>					
31	Financing	Obtaining and maintaining private sector financing for the Project.			•
32	Base interest rate risk	Base interest rate risk prior to Financial Close. Base interest rate risk from Financial Close to the first re-finance date. Base interest rate risk from the first refinance date.	•  •		•
33.1	Refinancing - downside	Any refinancing that results in a refinancing loss will be borne by Project Co.			•
33.2	Refinancing - upside	Any refinancing that results in a refinancing gain will be shared 50/50 with the State (except where a refinancing gain arises from a change in the manner or timing of payment of a State contribution in which case the State will be entitled to 100 per cent of such refinancing gain).		•	
34	Tax	Actual tax payable by Project Co differs from the base case financial model.			•
35	Forex risk – delivery phase	Risk of forex movements (excluding agreed overseas sourced spare parts).			•
36	Forex risk – maintenance phase	Agreed overseas sourced spare parts.		•	

### 3.4 GENERAL OBLIGATIONS OF PROJECT CO

#### Delivery phase

Project Co is required to design, construct and commission 65 HCMTs, the depot (including the TMF), LSF and simulators. In parallel with these activities, Project Co is required to undertake operational readiness activities necessary to ensure that it is able to maintain and operate the various assets as required under the Project Agreement.

#### Maintenance phase

Project Co is required to provide a range of services in respect of the various assets and infrastructure, including the maintenance of the HCMTs during the maintenance phase of the Project. The services are to be provided throughout the maintenance phase in accordance with the various standards set out in the Project Agreement.

Project Co is required to make the HCMTs available to the Franchisee for operation on the Melbourne metropolitan rail network. Details of the regime regarding the required availability are set out in the Project Agreement and the Franchisee Cooperation Agreement.

Table 10 summarises the services to be provided by Project Co. Full details of the services and the key performance indicators are contained in the Project Agreement.

**Table 10: Summary of services to be provided by Project Co**

Services	Includes
Maintenance	Maintenance of: <ul style="list-style-type: none"> <li>- the HCMTs</li> <li>- each simulator</li> <li>- the TMF</li> <li>- the LSF</li> <li>- all assets and systems which form part of the above assets.</li> </ul>
Operation of infrastructure	Operation of: <ul style="list-style-type: none"> <li>- the TMF</li> <li>- the LSF</li> <li>- each simulator.</li> </ul>
Provision of required availability	Making the required number of HCMTs available for service.

### 3.5 GENERAL OBLIGATIONS OF THE STATE

Under the Project Agreement, the State's obligations include the following:

- the State must provide Project Co with the necessary access to allow it to perform its obligations
- the State may review and comment on design documentation and other material that will be submitted by Project Co in accordance with the Project Agreement
- the State must pay to Project Co the State contributions on the relevant dates and the QSPs during the transition-in-phase and maintenance payment phase subject to any abatement that may apply if services are not delivered to the required standard.

### 3.6 OTHER CHANGES IN COST TO THE STATE

#### 3.6.1 Modifications

The State may, at its sole discretion, request Project Co to implement modifications to the HCMTs or the Project activities provided that the State adequately compensates Project Co in accordance with the Project Agreement.

#### 3.6.2 Change in law

The State bears the risk of cost increases or savings arising from certain changes in law and policy.

## 3 Key commercial features

### 3.6.3 Other changes in costs

Subject to certain conditions, Project Co may be entitled to performance relief under the Project Agreement and to payment by the State of certain additional costs and expenses incurred by it as a result of the following events:

- during the Project term:
  - breach by the State of any Project documents
  - a breach by the Franchisee of its obligations under the Franchisee Cooperation Agreement or the fraud or wilful default of the Franchisee
  - suspension of the works as required by law, the Commonwealth or the State because of a native title claim or the discovery of artefacts
  - a legal action to, or any review or revocation of, alteration, amendment, variation or change to, certain planning or environmental approvals for which the State is responsible
  - industrial action which directly affects the Project and which Project Co can demonstrate is a direct result of an act or omission of the State or a State-related party at the depot site or LSF site (during the delivery phase) or the depot site, LSF site or, stabling yards (during the maintenance phase) other than any act or omission authorised or permitted under any Project document
  - industrial action in respect of the Project activities in relation to the introduction of the Fleet into passenger services or due to the implementation of high capacity signalling
  - if the State directs the suspension of the works, except to the extent such suspension was due to a breach of a Project document or a negligent act or omission of Project Co or its associates, or a force majeure event
  - the carrying out of works by the State which are in proximity to the depot site or TMF site or the LSF site (as applicable) or which have been omitted from the scope of the Project by the State.
- during the delivery phase:
  - any act or omission of the State (in its contracting capacity) or the State's associates, other than any act or omission which is authorised or permitted under the Project Agreement or is an exercise of a government authority's statutory authority
  - the State directs that additional tests be carried out, except where the results of that test show that there is a problem with the works
  - a step-in by the State as a result of an incident or under a statutory power (but not step-in in circumstances related to a force majeure event or a Project Co default
  - a failure by the Franchisee or PTV to comply with the protocol in respect of the implementation of the ICT shore systems
  - a failure by the State to replace defective free issue material
  - damage to a HCMT is caused while it is outside the care, custody and control of Project Co
  - remediation of contamination for which the State is responsible under the Project Agreement.
- during the maintenance phase, a fraudulent, reckless, unlawful or malicious act or omission of the State or any of its associates in connection with the Project.

### 3.7 DEFAULT, STEP-IN AND TERMINATION REGIME

#### Default

A default by Project Co under the contractual arrangements will entitle the State to various remedies. Where a default has occurred, the State will, in most circumstances, be required to give Project Co an opportunity to cure the default. If the default is not cured by Project Co within the required cure period, it will escalate to a major default.

The Project Agreement also elevates a number of events to be classified in the major default category (such as persistent breaches).

In respect of major defaults, Project Co will be given the opportunity to agree a cure plan with the State. Where Project Co fails to cure the major default in accordance with the cure plan, this will generally, subject to financier step-in rights, give rise to the State's right to terminate the Project Agreement.

Certain events of default are so severe that they are not subject to a cure regime. They give rise to a State termination right immediately upon their occurrence (for example, insolvency of Project Co or whole or partial abandonment of the activities by Project Co). These events are called default termination events.

### Step-in

In addition to triggering termination rights (or potential termination rights), events of major default and default termination events may trigger additional State rights and remedies including the right to step-in to remedy the situation (that is, the right to assume control and management of the Project).

Step-in rights for the State, as specified in the Project Agreement, can be triggered when:

- a major default has occurred and Project Co is not complying with its cure plan
- a default termination event has occurred
- a cure notice has been issued by a key subcontractor
- a law entitles the State to a statutory right of step-in.

The default-related step-in right is subject to any step-in rights the financiers may have. During any step-in associated with a default, the QSP will be abated to the extent that the services are not being provided.

### Termination

Where the Project Agreement is terminated before the natural expiry of the intended 30 year maintenance phase, Project Co may be entitled to a termination payment. The Project Agreement can be terminated as a result of the following:

- certain events of default
- a force majeure termination event
- voluntarily by the State.

The basis for the calculation of the termination payment will be determined by the reason for the termination as summarised in Table 12. In the event that the termination payment is a negative amount, Project Co must pay that amount to the State.

**Table 12: Calculation of termination payments**

Event	Trigger	Termination payments
Default termination event	The State may terminate the Project Agreement if a default termination event occurs.	The Project's fair market value determined by tendering or by an independent valuer, including where there is no liquid market.
Termination for force majeure	The occurrence of a force majeure termination event.	The outstanding debt as at the termination date plus other costs.
Voluntary termination	The State may, at any time, for reasons of its own choosing, unilaterally elect to terminate the Project Agreement for convenience.	The outstanding debt as at termination date and other reasonable costs (including a capped amount of break costs during the delivery phase and a return to equity).

## 3 Key commercial features

### 3.8 FINANCE AND SECURITY ARRANGEMENTS

Project Co is responsible for the provision of debt and equity finance for the Project. Its funding structure comprises senior debt drawn progressively from Financial Close and equity committed at Financial Close by way of equity letters of credit, with the equity funding drawn during construction.

Up to 30 per cent of the forecast amount of debt outstanding at provisional acceptance of the Project will be repaid by State contributions. The remaining debt is for an initial period of eight years from Financial Close. Debt will then be refinanced at intervals over the Project term. The State will not share in any refinancing losses, but will be entitled to 100 per cent of the benefit of any refinancing gain where arising from a change in the payment of a State contribution, and 50 per cent of the benefit of any other refinancing gains (after allowing Project Co to recoup any prior refinancing losses).

### 3.9 AUDIT AND INSPECTION RIGHTS OF THE STATE

The Project Agreement includes contractual rights for the State to be given access to information and data, including to:

- inspect or observe any part of the assets or project activities
- examine and make copies of the accounts and other records, reports and all documents reasonably requested of Project Co or any of its subcontractors in connection with the Project.

The State also has the ability to disclose information in connection with the Project to satisfy the disclosure requirements of the Victorian Auditor-General or to satisfy the requirements of Parliamentary accountability.

### 3.10 PROCESS FOR GOVERNMENT MODIFICATION OF SERVICES/FACILITY

The State may, at its sole discretion, request Project Co implement modifications (to the HCMTs, the depot, the LSF, the simulators or the Project activities) provided the State adequately compensates Project Co.

This includes an ability to remove works or services from the Project scope. Under the modifications regime, Project Co must provide an estimate of the costs or savings impact of any modification proposed by the State in a manner which complies with the requirements of the Project Agreement. All costs must be provided on an open book basis. To provide greater transparency and certainty around modification costs, the Project Agreement specifies a range of pre-agreed margins and other on-costs Project Co can claim in such circumstances. There are a number of pre-agreed costs for modifications which may be requested by the State, including for additional HCMTs.

The State may pay for the modification either by way of a lump sum, milestone payments or an adjustment to the QSP or a combination of such methods.

### 3.11 STATE RIGHTS AT EXPIRY OF CONTRACT

The Project Agreement requires Project Co to hand back the HCMTs, simulators, TMF and LSF at the expiry of the maintenance phase in a condition that meets the requirements of the Project Agreement. The State will then resume control of those sites and assets.

To ensure that the assets are in sound working order, the HCMTs, simulators, TMF and LSF will be independently inspected on a six-monthly basis in the four years leading to the expiry of maintenance phase to ensure that all lifecycle and maintenance works have been completed and that the assets will meet the relevant transition-out conditions. The transition-out provisions are described in the Project Agreement.

If Project Co fails to maintain the relevant assets to the standards required to satisfy the transition-out requirements, the State will be entitled to withhold a portion of the QSP to cover the expense of any shortfall.

## Appendix 1 – Glossary

Term	Meaning
<b>CCTV</b>	Closed circuit television
<b>CPLU</b>	Cranbourne Pakenham Line Upgrade Project
<b>Contract Close</b>	The date on which the State and Project Co entered into the Project Agreement. This occurred on 21 November 2016
<b>DEDJTR</b>	Department of Economic Development, Jobs, Transport and Resources
<b>EOI</b>	Expressions of Interest
<b>Evaluation Criteria</b>	The criteria used by the State to evaluate Proposals as set out in Appendix 4.
<b>Fleet</b>	The new metropolitan train fleet consisting of 65 HCMTs
<b>Financial Close</b>	The date on which Project Co satisfied all of the conditions to be met in order for its debt providers to make funds available to it. This occurred on 24 November 2016
<b>HCMT</b>	High Capacity Metro Trains
<b>Initial Fleet</b>	The first 37 HCMTs
<b>ICT</b>	Information and Communication Technology
<b>LSF</b>	Light Services Facility
<b>NPC</b>	Net present cost
<b>Partnerships Victoria</b>	A State policy that provides a framework for developing contractual relationships between the State and private sector for the delivery of public infrastructure and related services through public private partnerships
<b>Project</b>	The High Capacity Metro Trains Project
<b>Proposal</b>	A Proposal submitted by a shortlisted Respondent in response to the State's RFP
<b>Public Interest Test</b>	The public interest test contained in Appendix 5
<b>Project Agreement</b>	The agreement entered into between the State and Evolution Rail for the delivery of the Project.
<b>PSC</b>	Public Sector Comparator
<b>Respondent</b>	An entity invited to submit a Proposal to deliver the Project
<b>RFP</b>	Request for Proposal
<b>TMF</b>	Train Maintenance Facility
<b>VIPP</b>	Victorian Industry Participation Policy

## Appendix 2: Useful references/links

The following references may be of further assistance.

Project documentation, including the Project Agreement, is available at:  
[www.tenders.vic.gov.au](http://www.tenders.vic.gov.au)

Department of Economic Development, Jobs, Transport and Resources  
[www.economicdevelopment.vic.gov.au](http://www.economicdevelopment.vic.gov.au)

Partnerships Victoria policy  
[www.dtf.vic.gov.au/Infrastructure-Delivery/Public-private-partnerships](http://www.dtf.vic.gov.au/Infrastructure-Delivery/Public-private-partnerships)

National PPP Guidelines  
[www.dtf.vic.gov.au/Infrastructure-Delivery/Public-private-partnerships](http://www.dtf.vic.gov.au/Infrastructure-Delivery/Public-private-partnerships)

High Value High Risk framework  
[www.dtf.vic.gov.au/Investment-Planning-and-Evaluation/High-Value-High-Risk](http://www.dtf.vic.gov.au/Investment-Planning-and-Evaluation/High-Value-High-Risk)



## Appendix 3: Key contact details

### **Department of Economic Development, Jobs, Transport and Resources**

Website: [www.economicdevelopment.vic.gov.au](http://www.economicdevelopment.vic.gov.au)

1 Spring Street

Melbourne VIC 3000

Phone: (03) 9651 9999

### **Partnerships Victoria**

Website: [www.dtf.vic.gov.au](http://www.dtf.vic.gov.au)

Department of Treasury and Finance

1 Treasury Place

East Melbourne VIC 3002

Phone: (03) 9651 5111

## Appendix 4: Evaluation Criteria

The State evaluated each Proposal against detailed evaluation criteria.

No.	Criteria	Description
<b>MC</b>	<b>Mandatory criterion</b>	
<b>MC1</b>	50% local content (ANZ) minimum requirement in the base offer	Whether the local content base offer meets 50 per cent local content (ANZ) minimum requirement for the delivery of the Fleet (VIPP).
<b>A</b>	<b>Local content, jobs and investment commitments</b>	
<b>A1</b>	Local content (ANZ) for the Fleet (VIPP)	The Respondent's demonstrated ability to achieve above the 50 per cent local content (ANZ) minimum requirement for the delivery of the Fleet.
<b>A2</b>	Local content (ANZ) for the depot and for the maintenance phase	The Respondent's demonstrated ability to meet the 80 per cent local content (ANZ) minimum target for the delivery of the depot and to meet the Respondent's local content commitments for the maintenance phase.
<b>A3</b>	Victorian content and local supply chain engagement	The Respondent's commitments to Victorian content and local supply chain engagement.
<b>A4</b>	Victorian jobs, training, apprenticeships and workforce development	The Respondent's commitment to developing the local workforce, including meeting the vocational training requirement and the disadvantaged worker requirement.
<b>A5</b>	Local investment commitment	The Respondent's commitment to developing Victoria's manufacturing industry, including any proposed capital investment in manufacturing facilities in Victoria.
<b>B</b>	<b>Technical solution</b>	
<b>B1</b>	Management requirements	The Respondent's initial delivery phase management plans and deliverables.
<b>B2</b>	Delivery program	The Respondent's proposed delivery program for the complete Project scope.
<b>B3</b>	HCMT technical solution	The Respondent's proposed HCMT solution and the degree to which the HCMT meets the requirements of the HCMT specification.
<b>B4</b>	Depot technical solution	The Respondent's proposed depot solution and the degree to which the depot meets the requirements of the depot specification.
<b>B5</b>	Simulator technical solution	The Respondent's proposed HCMT simulator solution and the degree to which the HCMT simulators meet the requirements of the simulator specification.
<b>B6</b>	ICT shore systems technical solution	The Respondent's proposed ICT shore systems solution and the degree to which it meets the requirements of the ICT shore systems specification.
<b>B7</b>	Additional information items and priced options	The Respondent's proposed solutions for the additional information items and priced options.
<b>B8</b>	LSF technical solution	The Respondent's proposed LSF solution and the degree to which the LSF meets the requirements of the LSF specification.
<b>B9</b>	Technical specification departures	The nature and extent of proposed departures from the RFP

No.	Criteria	Description
<b>C Maintenance and operational services solution</b>		
C1	Maintenance phase methodology	The Respondent's proposed maintenance phase methodology and approach, including management plans and policies.
C2	HCMT maintenance solution	The Respondent's proposed maintenance solution and the operational services for the HCMT.
C3	Simulator maintenance solution	The Respondent's proposed maintenance plan and the support services for the simulator.
C4	TMF site and LSF site maintenance solution	The Respondent's proposed site maintenance solution and the proposed method of conducting operations at the TMF and LSF.
C5	Maintenance and operational services specification departures	The nature and extent of proposed departures from the requirements of the RFP
<b>D Commercial and financial solution</b>		
D1	Project Co governance and interfaces	The appropriateness of Project Co's management structure, intra-consortium relationships and stakeholder management.
D2	Commercial solution	The appropriateness of the Respondent's commercial solution.
D3	Acceptance of risk profile	The nature and extent of the proposed departures from the draft state project documents and the Franchisee Cooperation Agreement.
D4	Financial capacity	The financial capacity of the Respondent to deliver the Project in its entirety.
D5	Financing structure	The appropriateness and robustness of the financing structure.
D6	Certainty and robustness of the financing Proposal	The certainty and robustness of the financing Proposal.
<b>E Value and risk proposition</b>		
E1	Risk adjusted cost of Proposal	The whole-of-life, risk adjusted cost of the Proposal by taking into account the financial and risk consequences of the Proposal.
E2	Financial model assumptions	The robustness and sustainability of the Respondent's financial assumptions.
E3	Value for money enhancements	The local content maximum offer and any alternative positions or options that would increase the value for money benefit to the State.

## Appendix 5: Public Interest Test

### Partnerships Victoria Public Interest Test

The Public Interest Test (PIT) is to assess whether or not the delivery of the PPP project is in the public interest. Ensuring that a PPP meets the public interest requires:

- ensuring that procuring the project as a PPP is in the public interest
- after a decision has been made to procure a project as a PPP, ensuring that the process is structured so that the project continues to be in the public interest.

In accordance with the Partnerships Victoria Requirements, procuring agencies are required to prepare a PIT at key stages of government approval (including prior to contract execution) to identify any changes to the public interest assessment and/or confirm that the project remains in the public interest.



Artist's impression – Pakenham depot.

## Public interest categories

The PIT for the Project has been updated prior to contract execution to ensure that it continues to comply with the following eight elements of public interest:

- effectiveness
- accountability and transparency
- affected individuals and communities
- equity
- consumer rights
- public access
- security
- privacy.



## Appendix 5: Public Interest Test

Element	Relevant Policy / Standard
<p><b>Effectiveness</b></p> <p>Is the Project effective in meeting government objectives?</p>	<p>The Project aligns with all relevant government policies and, in particular, the following key policies:</p> <p><i>Plan Melbourne 2014<sup>4</sup></i></p> <p>Provide an integrated transport system connecting people to jobs and services, and goods to market.</p> <p>Provide a major uplift in the capacity of our rail system via a pipeline of city-shaping transport projects, generating benefits to travellers across the whole network.</p> <p><i>Getting on with it: Fast-tracking the projects our State needs.</i></p> <p><i>Rolling Stock Strategy: Trains, Trams, Jobs 2015 to 2025 (Rolling Stock Strategy).</i></p> <p><i>Victorian Industry Participation Policy (VIPP).</i></p> <p>The VIPP requires Victorian Government departments and agencies to consider opportunities for competitive local suppliers, including SMEs, when awarding contracts.</p>
<p><b>Accountability and transparency</b></p> <p>Do the partnership arrangements ensure that:</p> <ul style="list-style-type: none"> <li>- the community can be well informed about the obligations of government and the private sector partner</li> <li>- these obligations can be oversighted by the Auditor-General</li> </ul>	<p>The Project is to comply fully with all Victorian Government accountability and transparency policies and obligations including under the:</p> <ul style="list-style-type: none"> <li>- <i>Freedom of Information Act 1982</i></li> <li>- Victorian Government Purchasing Board Probity Policy</li> <li>- Best Practice Probity Advice Guidelines</li> <li>- Victorian Auditor-General .</li> </ul>
<p><b>Affected individuals and communities</b></p> <p>Have those affected been able to contribute effectively at the planning stages, and are their rights protected through fair appeals processes and other conflict resolution mechanisms?</p>	<p>The Project must conduct, or be compliant with:</p> <ul style="list-style-type: none"> <li>- an appropriate public consultation process with those individuals/ groups identified as being affected by the Project</li> <li>- the Regional Development Victoria (RDV) framework (including the Victorian Industry Participation Policy)</li> <li>- environmental, OH&amp;S and other assessments of the site</li> <li>- local government planning requirements.</li> </ul>

4. Note that Plan Melbourne is undergoing a refresh at the time of writing.

## Assessment

The Project is closely aligned with a number of State policy objectives; in particular, those which relate to the provision of public transport, and those which promote sustainable population growth (along with access to jobs and services). In this context, the preliminary business case, project development plan and the tender documents for the Project specify an output/service delivery solution which is consistent with government policy as outlined below.

The Cranbourne Pakenham Line Upgrade project (CPLU), of which the Project forms an important part, sits alongside the Metro Tunnel and the Level Crossing Removal Project, as key initiatives underpinning the government's public transport strategy. The CPLU will create thousands of jobs, ease congestion and reduce travel times for the one million people living in Melbourne's south-east corridor.

The Project supports this policy by seeking to transform the public transport system, reduce road congestion and improve safety for the travelling public through the procurement of 65 new HCMTs, a new dedicated TMF, an LSF and stabling yards in Pakenham East.

The Rolling Stock Strategy sets out the State's 10-year plan to provide a coordinated approach to the delivery of 100 new trains as well as significant investment in the State's tram Fleet and regional train Fleet. The 65 HCMTs announced as part of this Project delivers a significant proportion of the 100 new trains for Melbourne's metropolitan network.

The Project is of strategic significance to the Victorian economy, and has therefore been declared a strategic project in accordance with the VIPP framework. The Project will be a significant contributor to the State's local job aspirations. The RFP documentation included a minimum of 50 per cent local content requirement for the train Fleet. In particular response to this requirement, the Preferred Respondent's solution includes:

- around 1,100 jobs, including throughout the supply chain
- 60 per cent Fleet local content, with all 65 HCMTs to be manufactured locally
- investment in training, skills development and apprenticeship opportunities
- provision of training and employment opportunities for indigenous Victorians and displaced automotive workers.

The community will be well informed about the obligations of both the Government and any private sector partners through several mechanisms, including:

- details of the relevant contracts, subject to commercial-in-confidence considerations, being published in accordance with Victorian Government policy
- information on the Project's performance being available in the department's annual report
- the *Freedom of Information Act* applying to the Project. The Auditor-General will have access to Project information in accordance with the Audit Act
- Victorian Government Purchasing Board Probity Policy and Best Practice Probity Advice guidelines are required to be followed
- an independent probity adviser overseeing the procurement process to ensure the process is fair and transparent and conducted in accordance with the Project's Probity Plan. The probity adviser will provide sign-off to government following the conclusion of the negotiation process with the preferred proponent
- the Auditor-General retaining the right to view all material. Private sector proponents will have an opportunity to identify any elements of their bid that they deem to incorporate intellectual property or other trade secret information.

Key government stakeholders have been consulted during the procurement, negotiation and completion phases for the Project. The following individuals/groups were identified as being affected by the Project:

- Metro Trains Melbourne (Franchisee)
- V/Line
- VicRoads
- VicTrack
- Other Accredited Rail Operator
- Rail, Tram and Bus Union
- Signal Sighting Steering Committee.

The train driver community will be an affected group within this process given that the driver's cab forms their primary workspace.

The technical specifications for the Project will ensure that the design of the driver's cab meets all OH&S standards and takes into consideration relevant human factors issues.

Further, during the design process a mock-up cab will be built to enable extensive consultation with drivers to obtain their direct input to cab design and the layout of controls amongst other factors.

A full site survey of the land allocated for the depot construction has been undertaken to assess environmental and other site issues, and an Environment Protection Authority Victoria-appointed environmental auditor has certified that the site is suitable for use.

## Appendix 5: Public Interest Test

Element	Relevant Policy / Standard
<p><b>Equity</b></p> <p>Are there adequate arrangements to ensure that disadvantaged groups can effectively use the infrastructure or access the related service?</p>	<p>The key disadvantaged groups expected to use the infrastructure and access the services are those with physical impairment, the aged and frail.</p> <p>The Project must comply with all relevant government laws and policies including:</p> <ul style="list-style-type: none"> <li>- <i>Disability Act 2006 and the Commonwealth Disability Discrimination Act 1992</i></li> <li>- <i>Disability Standards for Accessible Public Transport 2002 (DSAPT)</i>.</li> <li>- <i>Racial Discrimination Act 1975</i></li> <li>- <i>Sex Discrimination Act 1974</i></li> <li>- <i>Equal Opportunities Act 1995</i>.</li> </ul>
<p><b>Public access</b></p> <p>Are there safeguards that ensure ongoing public access to essential infrastructure?</p>	<p>The Project must make the HCMTs available to the Franchise for ongoing public access (as appropriate) to the HCMTs.</p> <p>All required and statutory public access will be provided, where it is safe to do so.</p> <p>All relevant public transport access requirements will be implemented.</p> <p>Appropriate contractual arrangements will be in place.</p>
<p><b>Consumer rights</b></p> <p>Does the Project provide sufficient safeguards for service recipients, particularly those for whom government has a high level of duty of care, and/or the most vulnerable?</p>	<p>Service recipients to whom government owes a high level of duty of care are children, seniors, low income earners, physically/mentally disabled, non-English speaking, overseas tourists, those not familiar with the transport system, etc.</p>
<p><b>Security</b></p> <p>Does the Project provide assurance that community health and safety will be secured?</p>	<p>The Project needs to ensure:</p> <ul style="list-style-type: none"> <li>- all relevant occupational health and safety standards are met in design, construction and operation / maintenance stages</li> <li>- government can meet its duty of care obligations to the public</li> <li>- accreditation requirements.</li> </ul>
<p><b>Privacy</b></p> <p>Does the Project provide adequate protection of users' rights to privacy?</p>	<p>Applicable privacy standards with which the Project is required to comply are set out in:</p> <ul style="list-style-type: none"> <li>- <i>Freedom of Information Act 1982</i></li> <li>- <i>Surveillance Devices Act 1999</i>.</li> </ul>



## Assessment

The Project complies with DSAPT regulations. Contractual provisions include adequate safeguards to ensure that Project Co complies with all laws which include common law and the principles of equity.

By its very nature the design of the new HCMTs will accommodate people with special needs in terms of physical access, necessitating an emphasis on the requirements under Disability legislation. The technical specifications will require the HCMT manufacturer to maximise accessibility to commuters with special needs and to be compliant with DSAPT requirements. As part of the design process, Project Co will be required to build a mock-up HCMT saloon to enable extensive consultation with the disabled community. This will enable direct input from that community to better inform the design in addressing accessibility issues.

During the negotiation phase, the State has required the preferred Respondent to update its HCMT design in order to accommodate the revised *Disability Discrimination Act* requirement (in relation to allowing for two ramps per HCMT, and the associated seating reconfigurations).

The HCMTs will be made available to the Franchise for operation under the Franchise Agreement for use and access by the public except during times when essential maintenance may be required.

Both the technical and contractual arrangements require Project Co to allow the required public access including adequate safeguards to ensure the continued supply of service to the public. The contract will include step-in rights for the State to take over the assets in the event of a contract breach.

Delivery of the project as an availability PPP means that payments to the private party will be abated for underperformance against contracted service levels.

The Project will meet all of the special needs and rights through adequate design, operation and maintenance.

As set out under the heading of “equity” the technical specifications will require the HCMT manufacturer to maximise accessibility to commuters with special needs. As part of the design process, Project Co will be required to build a mock-up HCMT saloon to enable extensive consultation and input from the disabled community and other special needs user groups to better inform the design and address any issues.

As above, delivery of the project as an Availability PPP means that payments to the private party will be abated for underperformance against contracted service levels.

The Project Agreement requires compliance (by all contractors involved) with the *Occupational Health and Safety Act 2004* (the Act) and all relevant codes of practice that establish health and safety guidelines supporting the Act.

Contract specifications will require HCMTs to be designed built and maintained in order to meet relevant occupational health and safety requirements in full.

The rolling stock manufacturer will need to have the HCMT accredited by Office of the National Rail Safety Regulator to operate in the Melbourne Underground Rail Line, and have regard for the Metro Tunnel project.

The Project will ensure the protection of rights to privacy through adherence to the *Freedom of Information Act 1982* and *Surveillance Devices Act 1999*, including:

- closed circuit television systems will be operated on the HCMTs in accordance with the *Surveillance Devices Act 1999*
- relevant privacy requirements will apply to the HCMTs.



Artist's impression – Pakenham depot.



Published by the Department of Economic Development, Jobs,  
Transport and Resources.

Prepared in conjunction with the Department of Treasury and Finance.

**Melbourne February 2017**

© State of Victoria (DEDJTR) 2017

The copyright in this document is owned by the State of Victoria, or  
in the case of some materials, by third parties (third party materials).  
No part may be reproduced by any process except in accordance  
with the provisions of the Copyright Act 1968 or with permission.

Authorised by the Department of Economic Development, Jobs,  
Transport and Resources.

1 Spring Street  
Melbourne, Victoria, 3000.

