



# Scaled and RAF Manned Research Projects

Compiled April, 2011

# Rutan Aircraft Factory

## Business Notes

- Founder-Owned and Operated for 12 years, from 1973 to 1985. Primary business – homebuilts
- Developed Fifteen Manned Aircraft Types:
  - All Concepts and Designs were done in-house
  - Twelve were Company-funded research programs
  - Thirteen were flight-tested in-house, accident-free
  - One (NASA AD-1) had Government customer
  - One (NGT-Fairchild) had Aerospace Prime customer
  - Seven were marketed to the public
- Business was small and consistently profitable

# Rutan Aircraft Factory Manned First Flights

#1 VariViggen Homebuilt Model #27  
First Flight - May 1972



# Rutan Aircraft Factory Manned First Flights

#2

VariEze POC

Model #31

May 1975



# Rutan Aircraft Factory Manned First Flights

#3 VariViggen SP Model #32SP July 1975



# Rutan Aircraft Factory Manned First Flights

#4 VariEze Homebuilt Model #33 March 1976



# Rutan Aircraft Factory Manned First Flights

#5 Quickie Homebuilt Model #54 November 1977



# Rutan Aircraft Factory Manned First Flights

#6

Defiant Homebuilt

Model #40

June 1978





# Rutan Aircraft Factory

# Manned First Flights

#7 Long-EZ Homebuilt

Model #61

June 1979



# Rutan Aircraft Factory Manned First Flights

#8

NASA AD-1

Model #35

December 1979

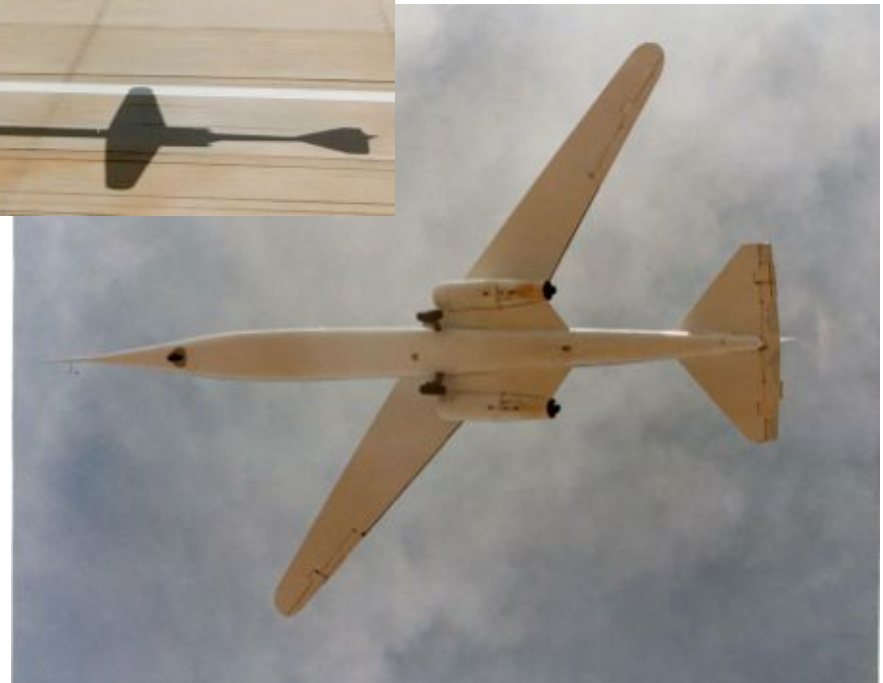
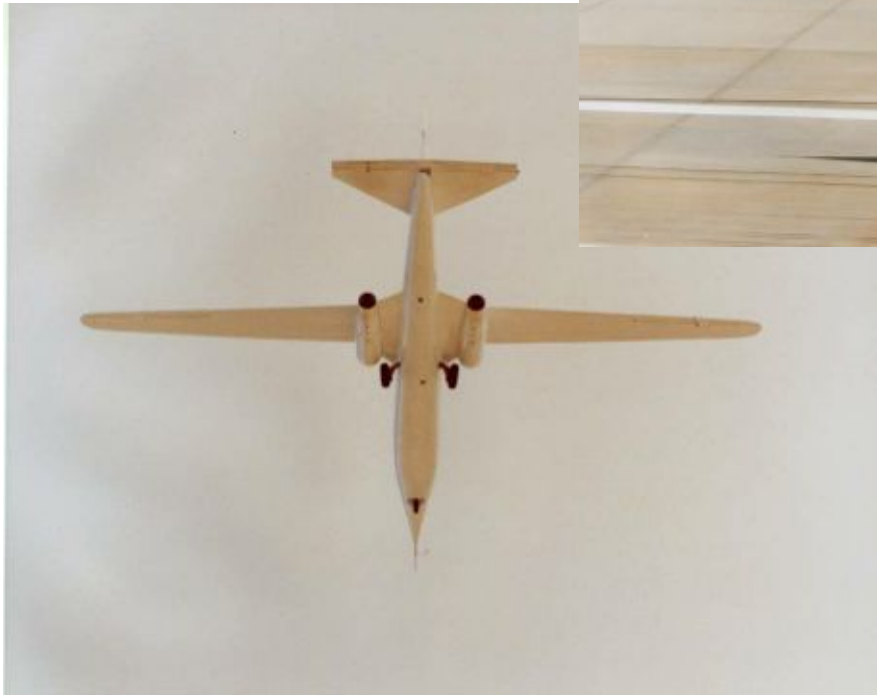

# Rutan Aircraft Factory Manned First Flights

#9 Amsoil Biplane Racer Model #68 August 1981

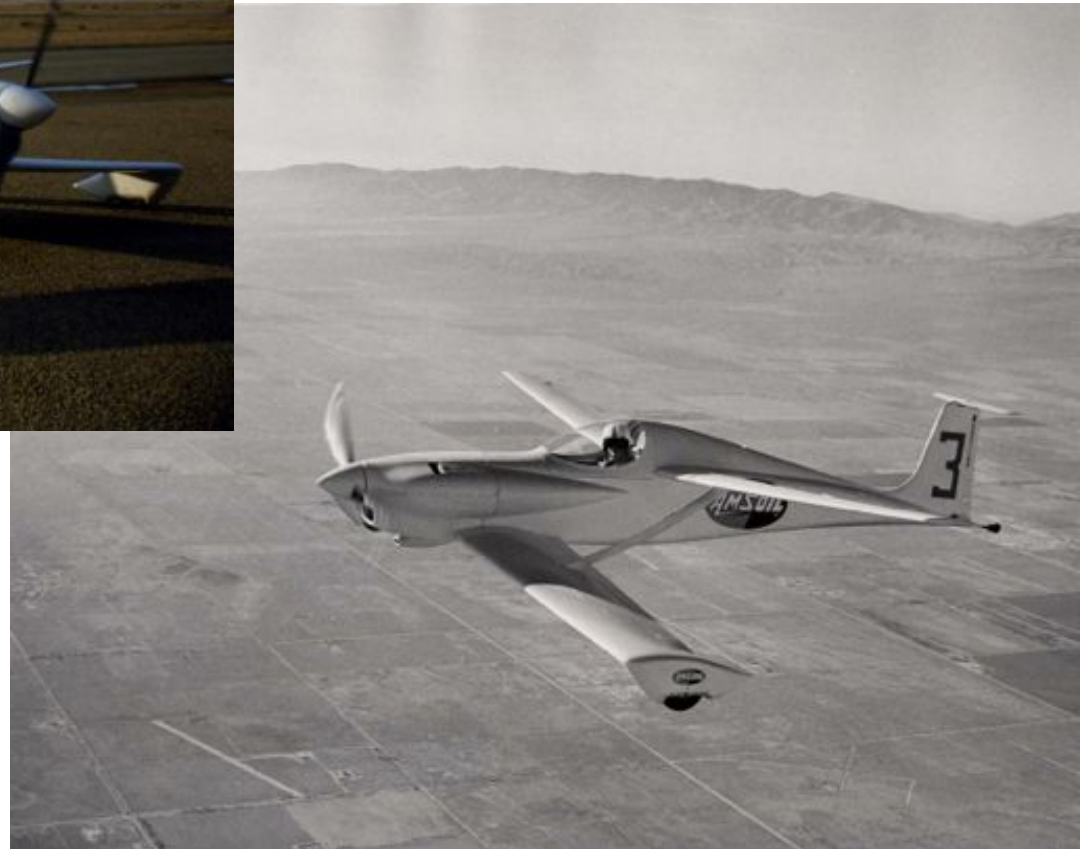
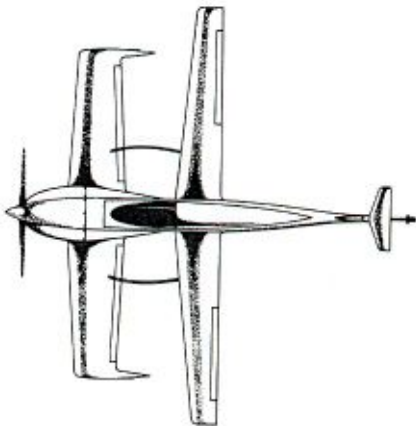

# Rutan Aircraft Factory Manned First Flights

#10 Next Generation Trainer Model #73 September 1981



# Rutan Aircraft Factory Manned First Flights

#11 Grizzly STOL Model # 72 January 1982



# Rutan Aircraft Factory Manned First Flights

#12 Solitaire Homebuilt Model #77 May 1982



# Rutan Aircraft Factory Manned First Flights

#13 Voyager RTW Model #76 VAI June 1984

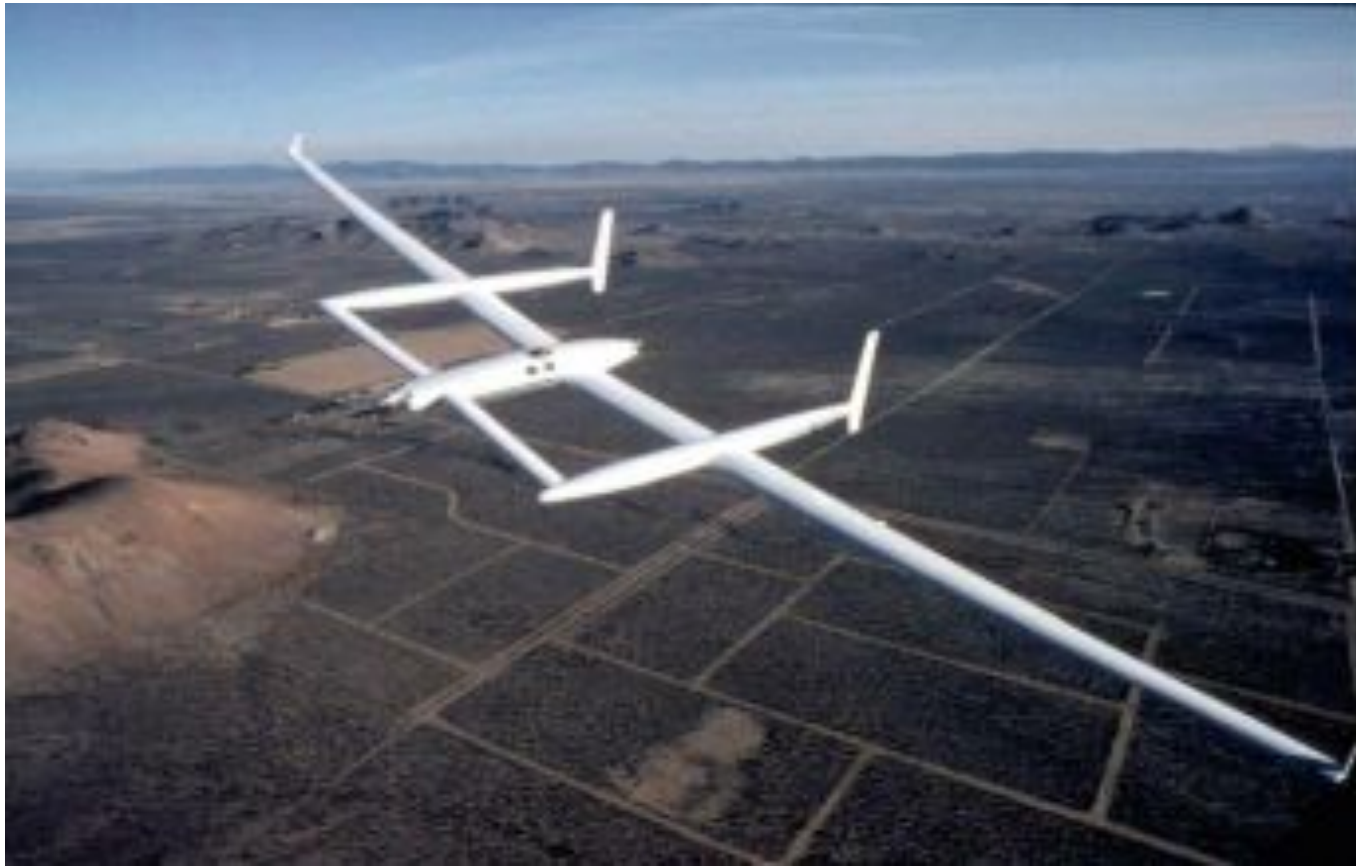

# Rutan Aircraft Factory Manned First Flights

#14

Catbird

Model #81

January 1988





# Rutan Aircraft Factory Manned First Flights

#15 Boomerang

Model #202

June 1996



# Scaled Composites

## Business Notes

- Founded in 1982. Aerospace Research.
- Developed 30 Manned Aircraft Types:
  - Concepts and Designs done in-house for 26 Types
  - Two Types developed to customer's detailed loft
  - Four were Company-funded research programs
  - 25 were flight-tested in-house; no major accidents
  - Six Types for U. S. Government customers
  - Four Types had a Prime Aerospace customer
  - Five Types had a Foreign customer
  - None were marketed to the public

# Scaled Composites: Manned First Flights

#1 Microlight Model #97 Lotus Motors January 1983



# Scaled Composites: Manned First Flights

#2 Starship Model #115 Beechcraft August 1983



# Scaled Composites: Manned First Flights

#3 Predator Crop-duster Model #120 ATAC Sept 1984



# Scaled Composites: Manned First Flights

#4 CM-44 Model #144 Calif Microwave February 1987



# Scaled Composites: Manned First Flights

#5 ATTT Model #133 DARPA December 1987



# Scaled Composites: Manned First Flights

#6 Triumph Model #143 Beechcraft July 1988





# Scaled Composites: Manned First Flights

#7	ATTT BT	Model #133b	DARPA	Dec 1988
----	---------	-------------	-------	----------



# Scaled Composites: Manned First Flights

#8 ARES Light Attack Model #151 February 1990



# Scaled Composites: Manned First Flights

#9 Lima I Lexus engine test Toyota April 1990



# Scaled Composites: Manned First Flights

#10 Pond Racer Model #158 Bob Pond March 1991



# Scaled Composites: Manned First Flights

#11 Lima II Model #191 Toyota November 1991



# Scaled Composites: Manned First Flights

#12 EarthWinds Gondola Model #181 November 1991



# Scaled Composites: Manned First Flights

#13 Raptor D-1 Model #226 DOE May 1993



# Scaled Composites: Manned First Flights

#14	Jet LEZ Vantage/ FJ107	Model #61B	Aug 1993
-----	------------------------	------------	----------

Proprietary



# Scaled Composites: Manned First Flights

#15 Raptor D-2 Model #226B DOE August 1994



# Scaled Composites: Manned First Flights

#16 VisionAire Vantage Model #247 November 1996



# Scaled Composites: Manned First Flights

#17 V-Jet II Model #271 Williams April 1997



# Scaled Composites: Manned First Flights

#18 Global Hilton Gondola Model #257 VAI Jan 1998



# Scaled Composites: Manned First Flights

#19 Proteus Model #281 Wyman Gordon July 1998



# Scaled Composites: Manned First Flights

#20

Roton ATV

Rotary Rocket

Mar 1999



# Scaled Composites: Manned First Flights

#21 Adam 309 Model #309 Adam Acft March 2000



# Scaled Composites: Manned First Flights

#22	Rodie	Model #61-C	Proprietary	Aug 2001
-----	-------	-------------	-------------	----------

Proprietary



# Scaled Composites: Manned First Flights

#24 White Knight Model #318 Paul Allen Aug 2002



# Scaled Composites: Manned First Flights

#23

TAA-1

Toyota

May 2002



# Scaled Composites: Manned First Flights

#25 SpaceShipOne Model #316 Paul Allen Aug 2003



# Scaled Composites: Manned First Flights

#26 GlobalFlyer Model #311 Marathon March 2004



# Scaled Composites: Manned First Flights

#27 Pulse-Detonation LEZ Model #61PD 2007



# Scaled Composites: Manned First Flights

#28 T-Tops/WhiteKnightTwo Model #348 Virgin Dec 2008



# Scaled Composites: Manned First Flights

#29 SpaceShipTwo Model #339 Virgin Oct 2010



# Scaled Composites: Manned First Flights

#30 Bipod Hybrid flying car Model #367 In-house Mar 2011

