

Service Manual

Soft-Touch Cassette Deck with
Auto Tape Selector

Cassette Deck
RS-5

(Silver Face)
(Black Face)

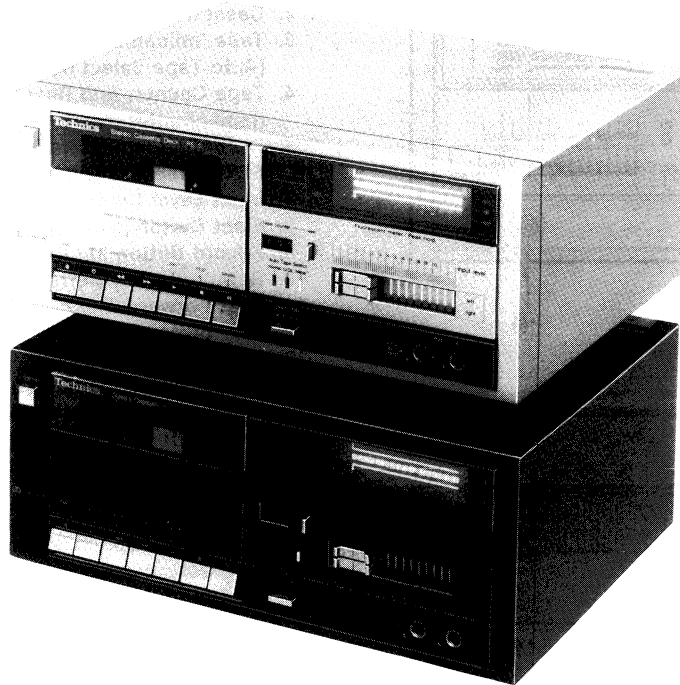
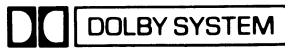

This is the Service Manual for the following areas.

- D** For all European areas except United Kingdom.
- B** For United Kingdom.
- N** For Asia, Latin America, Middle East and Africa areas.
- A** For Australia.

RS-M24 MECHANISM SERIES

Specifications

Track system:	4-track 2-channel stereo recording and playback	Outputs:	LINE; output level 400mV, output impedance 2.0k Ω or less
Tape speed:	4.8cm/s	Bias frequency:	80kHz
Wow and flutter:	0.05% (WRMS), $\pm 0.14\%$ (DIN)	Motor:	Electrical DC governor motor
Frequency response:	Metal tape; 20—17,000Hz 30—15,000Hz (DIN)	Heads:	2-head system; 1-MX head for record/playback 1-double-gap ferrite head for erasure
	CrO ₂ tape; 20—16,000Hz 30—15,000Hz (DIN)	Power requirement:	D ... AC 220V, 50-60Hz B ... AC 240V, 50Hz for United Kingdom. N ... AC 110/125/220/240V, 50-60Hz A ... AC 240V, for Australia.
	Normal tape; 20—15,000Hz 30—14,000Hz (DIN)	Power consumption:	D B A ... 15W N 11W
Signal-to-noise ratio:	Dolby* NR in; 67dB (above 5kHz) Dolby NR out; 57dB (signal level = max. input level A weighted, CrO ₂ type tape)	Dimensions:	31.5cm(W) \times 12.4cm(H) \times 24.8cm(D)
Fast forward and rewind time:	Approx. 90 seconds with C-60 cassette tape	Weight:	3.2kg
Inputs:	MIC; sensitivity 0.25mV, applicable microphone impedance 400 Ω —10k Ω LINE; sensitivity 60mV, input impedance more than 47k Ω		

Specifications are subject to change without notice.

* 'Dolby' and the double-D symbol are trademarks of Dolby Laboratories.

Technics

Matsushita Electric Trading Co., Ltd.
P.O. Box 288, Central Osaka Japan

CONTENTS

ITEM	PAGE	ITEM	PAGE
LOCATION OF CONTROLS AND COMPONENTS FOR CONNECTION WITH THE DIRECT CONNECTOR	2	BLOCK DIAGRAM.....	10
DISASSEMBLY INSTRUCTIONS	3	SCHEMATIC DIAGRAM	11
MEASUREMENT AND ADJUSTMENT METHODS	4	CIRCUIT BOARDS AND WIRING CONNECTION DIAGRAM	15
ELECTRICAL PARTS LOCATION.....	9	MECHANICAL PARTS LOCATION	18
		CABINET PARTS LOCATION.....	20

LOCATION OF CONTROLS AND COMPONENTS

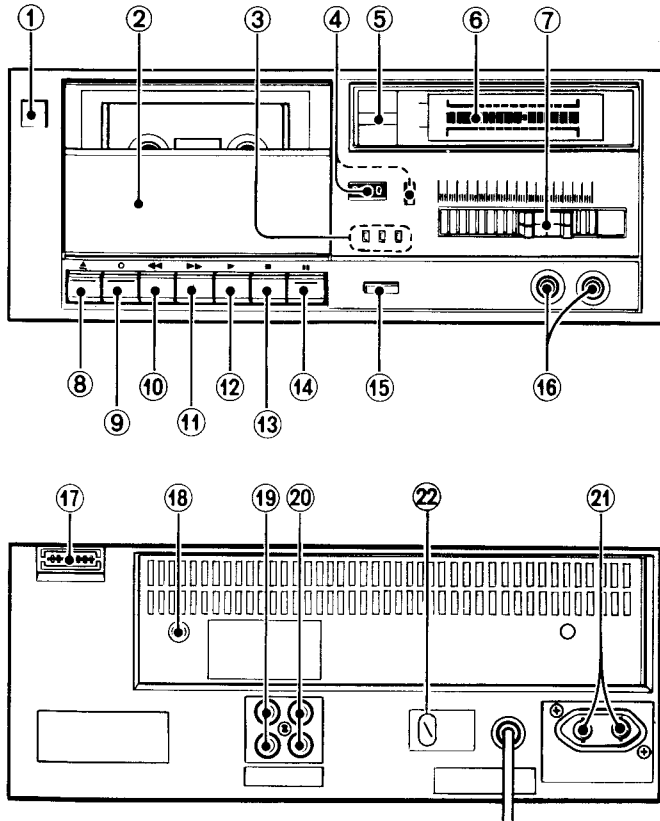

1. Power Switch [power (push on)]
2. Cassette Holder
3. Tape Indicators [Auto Tape Select (Normal · CrO₂ · Metal)]
4. Tape Counter and Reset Button (tape counter-reset)
5. Recording Indicators [rec]
6. FL (fluorescent level) Meters
7. Input Level Controls [input level (left · right)]
8. Eject Button [eject (▲)]
9. Record Button [rec-□ (○)]
10. Rewind/Review Button [rew/rev (◀◀)]
11. Fast Forward/Cue Button [ff/cue (▶▶)]
12. Play Button [play-□ (▶)]
13. Stop Button [stop (■)]
14. Pause Button [pause (⏸)]
15. Dolby Noise-Reduction Switch [Dolby NR (■ out · - in)]
16. Microphone Jacks [mic (L · R) (Auto Input Select)]
17. Direct Connector
18. Fixing Pin
19. Line Input Jacks [LINE IN (R · L)]
20. Line Output Jacks [LINE OUT (R · L)]
21. AC Outlet Unswitched
 - * For All European areas.
 - * For Asia, Latin America, Middle East and Africa areas.
22. AC Power Voltage Selector
 - * For Asia, Latin America, Middle East and Africa areas.

FOR CONNECTION WITH THE DIRECT CONNECTOR

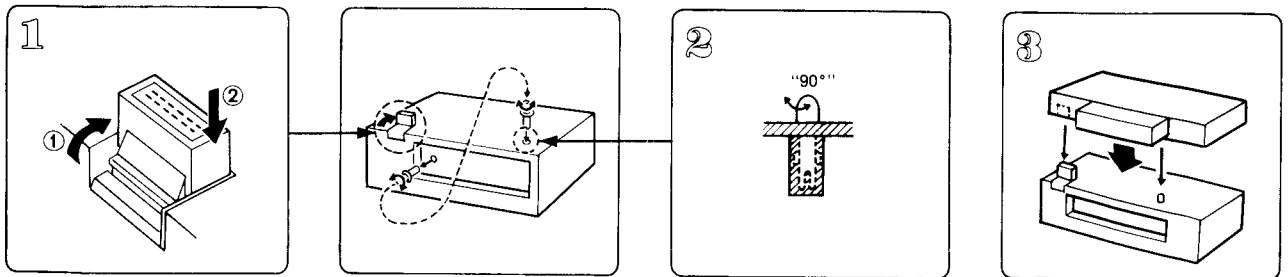

Connections should be made in accordance with the connection diagram and the following instructions: When 2 microphones are used in order to record in stereophonic sound, be sure both of them have the same performance and specification standards.

1. For connection with the direct connector:

- Connection can be made without using the stereo pin cords when the unit and TECHNICS' SU-5 Stereo Amplifier and ST-5 FM/AM tuner are stacked up for use.
- Set the direct connector to the erect position, replace the fixing pin at the unit's rear panel on the unit's top and connect the stereo amplifier properly (the fixing pin can be removed by rotating it 90°).

Notes:

- The stereo pin cords must be detached when connection is made using the direct connector.
- Do not shake or twist the components since they will unnecessarily strain the direct connector and fixing pin and may damage them in the process.

2. For connection with the stereo pin cords

- Connection is made with the stereo pin cords when this unit is used in combination with the SU-5 stereo amplifier, ST-5 FM/AM tuner or other components.

Notes:

- Do not set the direct connector to the erect position.
- Secure the fixing pin to the unit's rear panel.

3. Location of this unit and stereo amplifier

If this unit is placed on top or next to the stereo amplifier, a "hum" noise may be heard during tape playback. Refer to the information below in order to avoid this.

- If the stereo amplifier and this unit are placed one above the other, leave as much space as possible between them, and place them where there is the least amount of hum.

- If the stereo amplifier and this unit are placed one beside the other, try reversing their positions, and place them where there is the least amount of hum.

A "click" noise may be heard when the Power Switch is turned on or off. To avoid this, be sure to set the volume control of the amplifier to the minimum position.

DISASSEMBLY INSTRUCTIONS

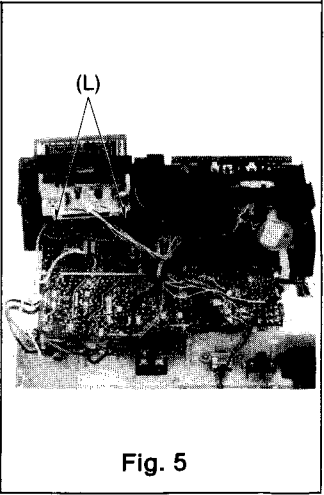
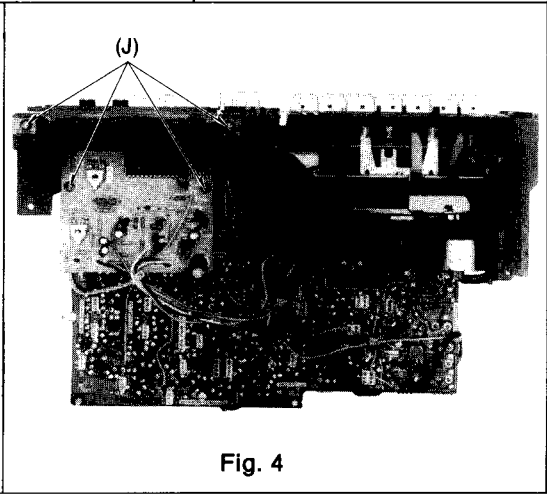
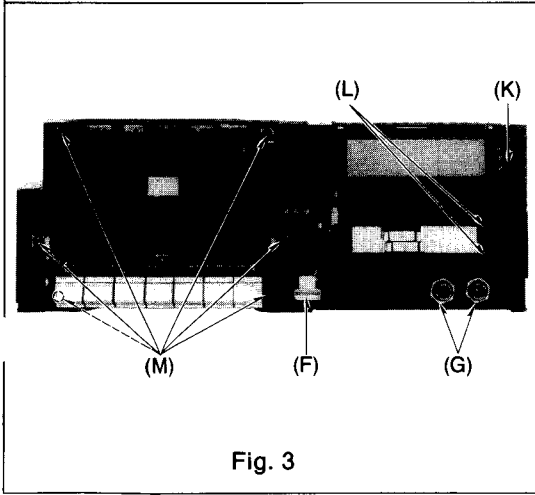
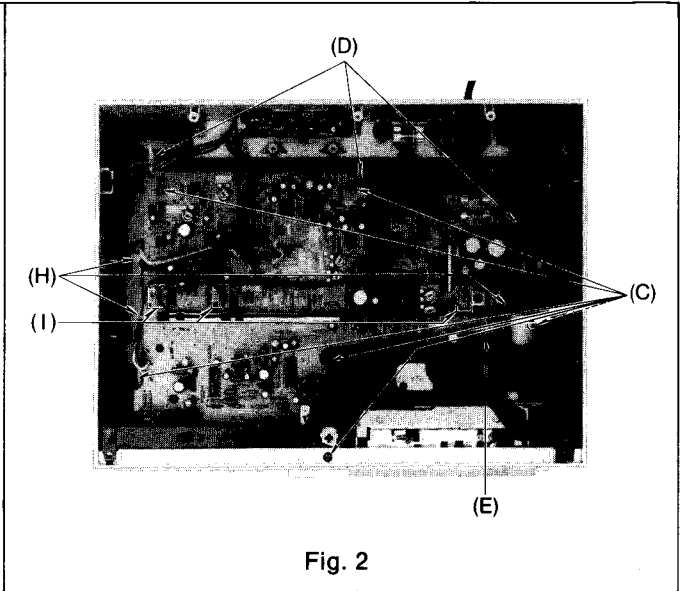
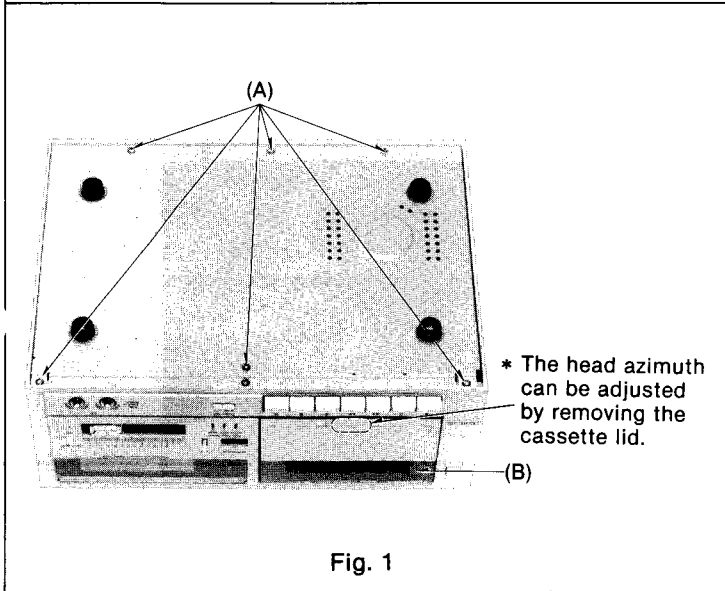

Ref. No.	Procedure	To remove ———	Remove ———	Shown in fig. ———
1	1	Bottom cover	• 6 screws(A)	1
2	1→2	Main circuit board and mechanism unit	• Cassette lid(B) • 6 screws(C) • Cord clamer(D)	1 2 2
3	1→2→3	Main circuit board	• Screw(E) • Dolby NR switch button(F) • 2 nuts(G) • Cord clamer(H) • 3 connectors.....(I)	2 3 3 2 2
4	1→2→4	FL meter circuit board	• 4 screws(J) • Meter cover-B and meter filter(K)	4 3
5	1→2→5	Input level control circuit board	• 4 screws(L)	3, 5
6	1→2→6	Mechanism unit	• 6 screws(M)	3

ASSEMBLY NOTES:

Precautions for mounting the input level control knob assembly

- Move the input level control lever and the input level control knob assembly to the right. Check that they engage each other as shown in fig. 6 and install the slide guide.

MECHANISM SECTION

1. For repair, measurement or adjustment with the mechanism removed from the unit be sure to ground the lower base plate of the mechanism.
2. For grounding, connect a extension cord to the mechanism's lower base plate and the lug terminal from amplifier printed circuit board.
3. Without grounding, the amplifier does not operate properly.

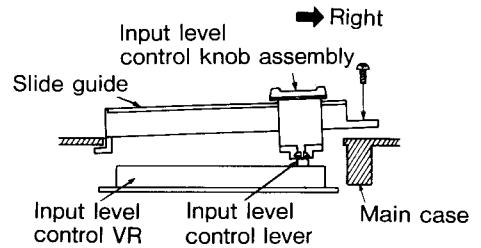
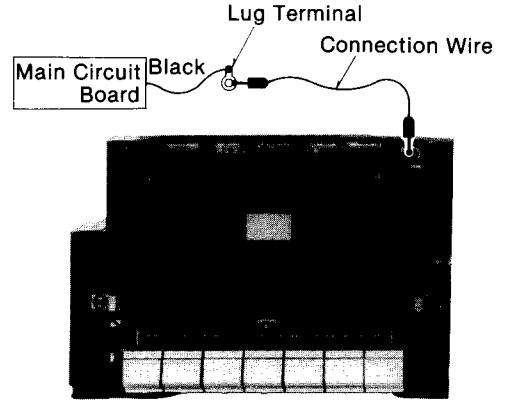

Fig. 6



MEASUREMENT AND ADJUSTMENT METHODS

NOTE:

Tape speed can be adjusted through the small hole on the back-side of main case by the ⊖ screw driver (non metal type) as shown in fig. 1.

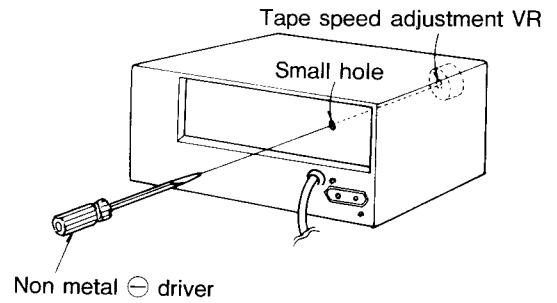

Fig. 1

ADJUSTMENT PARTS LOCATION

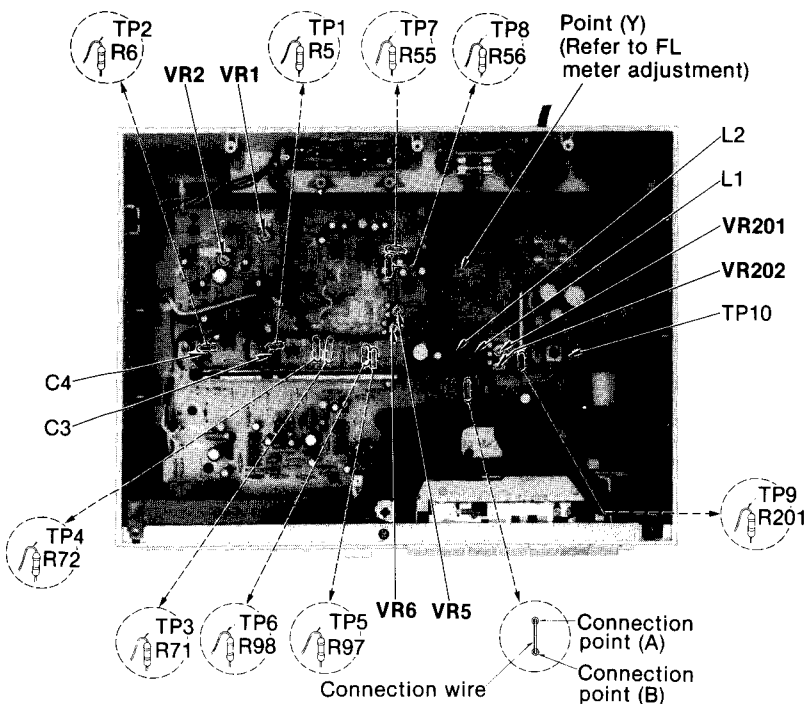
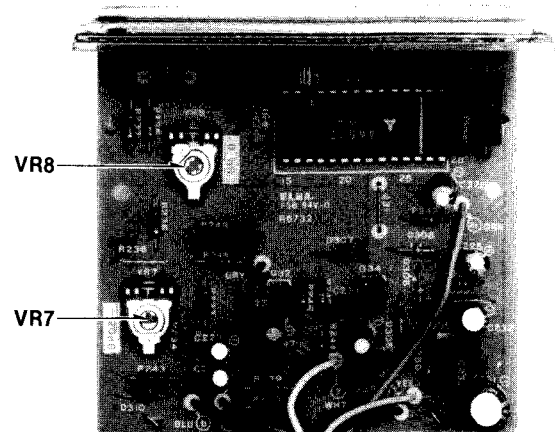
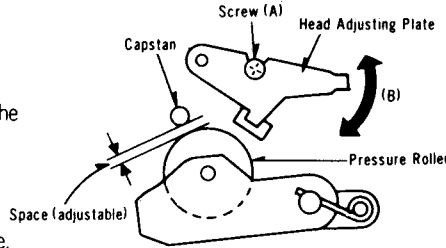
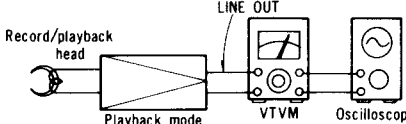
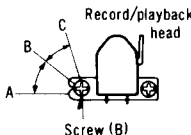
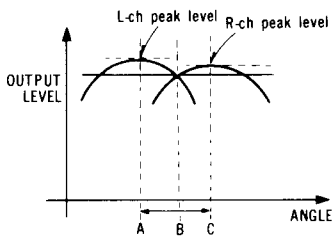
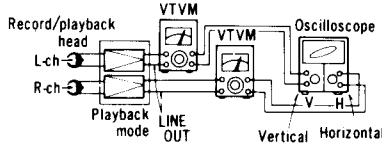
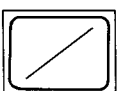
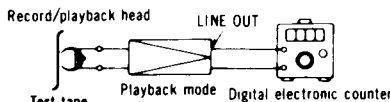

Fig. 2



NOTES: Keep good condition, set switches and controls in the following positions, unless otherwise specified.

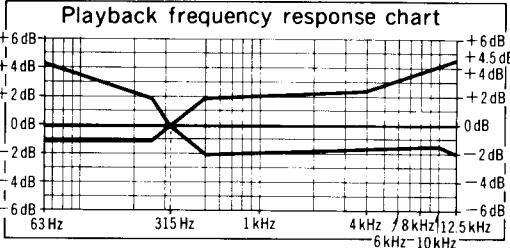
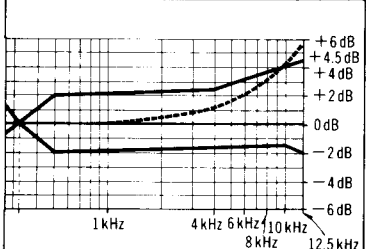
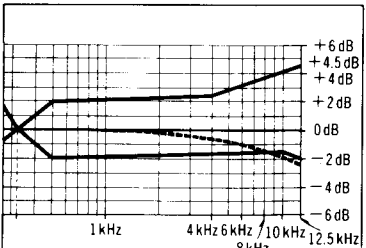
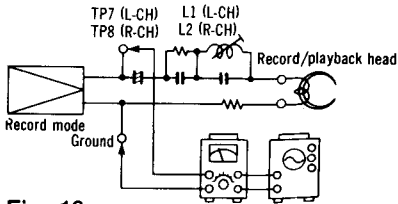

- Make sure heads are clean.
- Make sure capstan and pressure roller are clean.
- Judgeable room temperature: 20 ± 5 °C (68 ± 9 °F)
- Dolby NR switch: OUT
- Input level controls: Maximum

ITEM	MEASUREMENT & ADJUSTMENT
<p>A Head position adjustment</p> <p>Condition:</p> <ul style="list-style-type: none"> • Playback and pause mode 	<p>(The head adjusting plate is provided to adjust the tape touch of the head in cue or review mode.)</p> <ol style="list-style-type: none"> 1 Press the playback button and pause button. 2 Measure the space between the pressure roller and the capstan. <div style="border: 1px solid black; padding: 5px; width: fit-content; margin: 10px auto;"> <p>Standard value: 0.5 ± 0.3 mm</p> </div> <ol style="list-style-type: none"> 3. If the measured value is not within the standard value, untighten screw (A), and slide the head adjusting plate in the direction of arrow (B) for adjustment.  <p style="text-align: center;">Fig. 3</p>
<p>B Head azimuth adjustment</p> <p>Condition:</p> <ul style="list-style-type: none"> • Playback mode • Normal tape mode <p>Equipment:</p> <ul style="list-style-type: none"> • VTVM • Oscilloscope • Test tape (azimuth) ... QZZCFM 	<p>L-ch/R-ch output balance adjustment</p> <ol style="list-style-type: none"> 1. Make connections as shown in fig. 4.  <p style="text-align: center;">Fig. 4</p> <ol style="list-style-type: none"> 2. Playback the 8kHz signal from the test tape (QZZCFM). Adjust screw (B) in fig. 5 for maximum output L-ch and R-ch levels. <p>When the output levels of L-ch and R-ch are not at maximum at the same time, readjust as follows.</p> <ol style="list-style-type: none"> 3. Turn the screw shown in fig. 5 to find angles A and C (points where peak output levels for left and right channels are obtained). Then, locate the angle B between angles A and C, i.e., a point where L-ch and R-ch output levels come together at maximum. (Refer to figs. 5 and 6.) <p>L-ch/R-ch phase adjustment</p> <ol style="list-style-type: none"> 4. Make connections as shown in fig. 7. 5. Playback the 8kHz signal from the test tape (QZZCFM). Adjust screw (B) shown in fig. 5 so that pointers of the two VTVMs swing to maximum and a waveform as illustrated in fig. 8 is obtained on the oscilloscope.  <p style="text-align: center;">Fig. 5</p>  <p style="text-align: center;">Fig. 6</p>  <p style="text-align: center;">Fig. 7</p>  <p style="text-align: center;">Fig. 8</p>
<p>C Tape speed</p> <p>Condition:</p> <ul style="list-style-type: none"> • Playback mode • Normal tape mode <p>Equipment:</p> <ul style="list-style-type: none"> • Digital electronic counter or frequency counter • Test tape ... QZZCWAT 	<p>Tape speed accuracy</p> <ol style="list-style-type: none"> 1. Test equipment connection is shown in fig. 9. 2. Playback test tape (QZZCWAT 3,000 Hz), and supply playback signal to frequency counter. 3. Take measurement at middle section of tape. 4. Measure this frequency. 5. On the basis of 3,000 Hz, determine value by following formula: $\text{Tape speed accuracy} = \frac{f - 3,000}{3,000} \times 100 (\%) \quad \text{where, } f = \text{measured value}$ <div style="border: 1px solid black; padding: 5px; width: fit-content; margin: 10px auto;"> <p>Standard value: ± 1.5%</p> </div> <p>Adjustment method</p> <ol style="list-style-type: none"> 1. Playback the test tape (middle) 2. Adjust so that frequency becomes 3,000 Hz 3. Tape speed adjustment VR shown in fig. 1.  <p style="text-align: center;">Fig. 9</p>

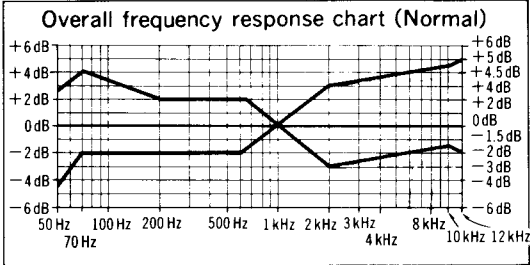
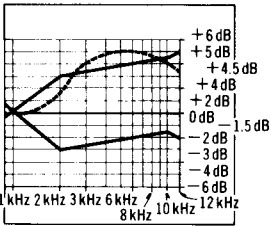
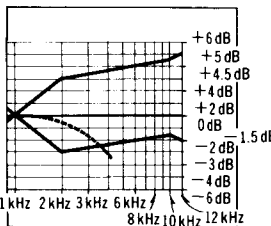
ITEM	MEASUREMENT & ADJUSTMENT																				
	<p>Tape speed fluctuation</p> <p>Make measurements in same manner as above (beginning, middle and end of tape), and determine the difference between maximum and minimum values and calculate as follows:</p> $\text{Tape speed fluctuation} = \frac{f_1 - f_2}{3,000} \times 100 (\%) \quad f_1 = \text{maximum value, } f_2 = \text{minimum value}$ <div style="border: 1px solid black; padding: 5px; width: fit-content; margin: 10px auto;"> <p>Standard value: Less than 1%</p> </div> <p>Note: Please use non metal type screwdriver when you adjust tape speed accuracy on this unit.</p>																				
<p>ⓐ Playback frequency response</p> <p>Condition:</p> <ul style="list-style-type: none"> • Playback mode • Normal tape mode <p>Equipment:</p> <ul style="list-style-type: none"> • VTVM • Oscilloscope • Test tape... QZZCFM 	<ol style="list-style-type: none"> 1. Test equipment connection is shown in fig. 4. 2. Place UNIT into playback mode. 3. Playback the frequency response test tape (QZZCFM). 4. Measure output level at 315Hz, 12.5kHz, 8kHz, 4kHz, 1kHz, 250Hz, 125Hz and 63Hz, and compare each output level with the standard frequency 315Hz, at LINE OUT 5. Make measurement for both channels. 6. Make sure that the measured value is within the range specified in the frequency response chart (shown in fig. 10). <div style="text-align: center;">  <p>Fig. 10</p> </div> <p>Adjustment</p> <ol style="list-style-type: none"> 1. If the measurement value increases in the high frequency range, as shown in fig. 11, remove capacitor C3 (L-CH) and C4 (R-CH) (Refer to fig. 2). <div style="text-align: center;">  <p>Fig. 11</p> </div> <p>Compensation value</p> <table border="1" style="margin: 10px auto;"> <tr> <td>6kHz</td> <td>8kHz</td> <td>10kHz</td> <td>12.5kHz</td> </tr> <tr> <td>-0.2dB</td> <td>-0.4dB</td> <td>-0.8dB</td> <td>-1.2dB</td> </tr> </table> <ol style="list-style-type: none"> 2. If the measurement value decreases in the high frequency range, as shown in fig. 12, insert and solder capacitors C3 (L-CH) and C4 (R-CH). <div style="text-align: center;">  <p>Fig. 12</p> </div> <p>Compensation value</p> <table border="1" style="margin: 10px auto;"> <tr> <td>6kHz</td> <td>8kHz</td> <td>10kHz</td> <td>12.5kHz</td> </tr> <tr> <td>+0.2dB</td> <td>+0.4dB</td> <td>+0.8dB</td> <td>+1.2dB</td> </tr> </table> <p>Capacitors</p> <table border="1" style="margin: 10px auto;"> <tr> <th>Ref. No.</th> <th>Part No</th> </tr> <tr> <td>C3, C4</td> <td>ECKD1H271KB</td> </tr> </table>	6kHz	8kHz	10kHz	12.5kHz	-0.2dB	-0.4dB	-0.8dB	-1.2dB	6kHz	8kHz	10kHz	12.5kHz	+0.2dB	+0.4dB	+0.8dB	+1.2dB	Ref. No.	Part No	C3, C4	ECKD1H271KB
6kHz	8kHz	10kHz	12.5kHz																		
-0.2dB	-0.4dB	-0.8dB	-1.2dB																		
6kHz	8kHz	10kHz	12.5kHz																		
+0.2dB	+0.4dB	+0.8dB	+1.2dB																		
Ref. No.	Part No																				
C3, C4	ECKD1H271KB																				
<p>ⓑ Playback gain</p> <p>Condition:</p> <ul style="list-style-type: none"> • Playback mode • Normal tape mode <p>Equipment:</p> <ul style="list-style-type: none"> • VTVM • Oscilloscope • Test tape... QZZCFM 	<ol style="list-style-type: none"> 1. Test equipment connection is shown in fig. 4. 2. Playback standard recording level portion on test tape (QZZCFM 315Hz), and using VTVM measure the output level at LINE OUT. 3. Make measurement for both channels <div style="border: 1px solid black; padding: 5px; width: fit-content; margin: 10px auto;"> <p>Standard value: 0.4V ± 2dB [around 0.42V: at test points TP3 (L-CH) and TP4 (R-CH)]</p> </div> <p>Adjustment</p> <ol style="list-style-type: none"> 1. If measured value is not within standard, adjust VR1 (L-CH), VR2 (R-CH) (See fig. 2 on page 4). 2. After adjustment, check "Playback frequency response" again. 																				
<p>ⓒ Bias leakage</p> <p>Condition:</p> <ul style="list-style-type: none"> • Record mode • Metal tape mode <p>Equipment:</p> <ul style="list-style-type: none"> • VTVM • Oscilloscope 	<ol style="list-style-type: none"> 1. Test equipment connection is shown in fig. 13. 2. Place UNIT into record mode. 3. Adjust trap coil L1 (L-CH), L2 (R-CH), so that measured value on VTVM becomes minimum. 4. Take adjustment for both channels. <div style="text-align: center;">  <p>Fig. 13</p> </div>																				

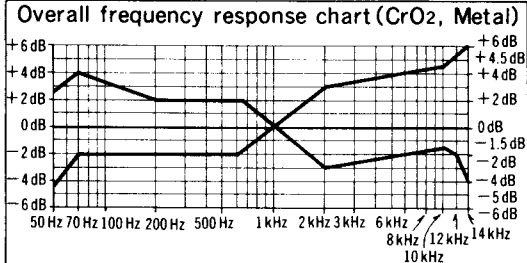
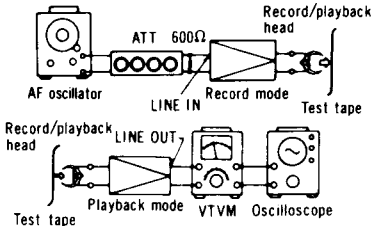
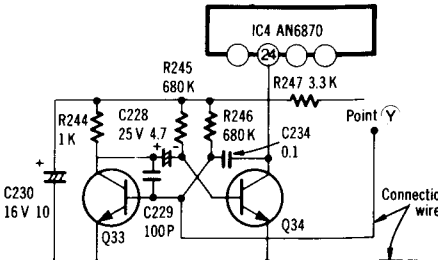
ITEM	MEASUREMENT & ADJUSTMENT
<p>⑥ Erase current</p> <p>Condition:</p> <ul style="list-style-type: none"> • Record mode • Metal tape mode <p>Equipment:</p> <ul style="list-style-type: none"> • VTVM • Oscilloscope 	<ol style="list-style-type: none"> 1. Test equipment connection is shown in fig. 14. 2. Place UNIT into record and metal tape mode and then measure voltage at test point 9. 3. Read voltage on VTVM and calculate erase current by following formula: $\text{Erase current (A)} = \frac{\text{Voltage across both ends of R201}}{1 (\Omega)}$ <div style="border: 1px solid black; padding: 5px; width: fit-content; margin: 10px auto;"> <p>Standard value: 155 ± 15 mA (Metal position)</p> </div> <ol style="list-style-type: none"> 4. If measured value is not within standard, adjust as follows. <p>Adjustment</p> <ol style="list-style-type: none"> 1. Open the point (A) and short the point (B) on the main circuit board in the wiring connection diagram (See page 15). 2. Make measurement for erase current. 3. Make sure that the measured value is within the erase current of 140 mA to 170 mA. 4. If it is beyond the value, carry out the following adjustments: <ul style="list-style-type: none"> • If the erase current is less than 140 mA, short the point (A) and (B). • If the erase current is more than 170 mA, open the points (A) and (B).
<p>④ Overall frequency response</p> <p>Condition:</p> <ul style="list-style-type: none"> • Record/playback mode • Normal tape mode • CrO₂ tape mode • Metal tape mode • Input level controls...MAX <p>Equipment:</p> <ul style="list-style-type: none"> • VTVM • AF oscillator • ATT • Oscilloscope • Resistor (600Ω) • Test tape (reference blank tape) <ul style="list-style-type: none"> ...QZZCRA for Normal ...QZZCRX for CrO₂ ...QZZCRZ for Metal 	<p>Note :</p> <p>Before measuring and adjusting, make sure of the playback frequency response (For the method of measurement, please refer to the playback frequency response).</p> <div style="text-align: center;">  <p>Fig. 15</p> </div> <p>Overall frequency response adjustment by recording bias current (Recording equalizer is fixed)</p> <ol style="list-style-type: none"> 1. Make connections as shown in fig. 17. 2. Place the UNIT into normal tape mode and load the test tape (QZZCRA). 3. Input a 1 kHz, -24 dB signal through LINE IN. Place the set in record mode. 4. Fine adjust the attenuator to obtain 0.4 V-LINE OUT output. <ul style="list-style-type: none"> • Make sure that the input signal level is -24 ± 4 dB with 0.4 V output voltage 5. Adjust the attenuator to reduce the input signal level by 20 dB. 6. Adjust the AF oscillator to generate 50 Hz, 100 Hz, 200 Hz, 500 Hz, 1 kHz, 4 kHz, 8 kHz, 10 kHz and 12 kHz signals, and record these signals on the test tape. 7. Playback the signals recorded in step 6, and check if the frequency response curve is within the limits shown in the overall frequency response chart for normal tapes (fig. 15). (If the curve is within the charted specifications, proceed to steps 8, 9 and 10.) If the curve is not within the charted specifications, adjust as follows: <div style="display: flex; justify-content: space-around; margin-top: 20px;"> <div style="width: 45%;"> <p>Adjustment (A):</p> <p>When the curve exceeds the overall frequency response chart specifications (fig. 15) as shown in fig. 18.</p> <div style="text-align: center;">  <p>Fig. 18</p> </div> </div> <div style="width: 45%;"> <p>Adjustment (B):</p> <p>When the curve falls below the overall frequency response chart specifications (fig. 15) as shown in fig. 19.</p> <div style="text-align: center;">  <p>Fig. 19</p> </div> </div> </div>

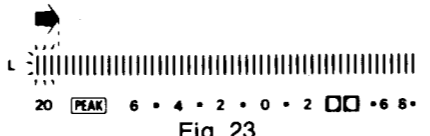
ITEM	MEASUREMENT & ADJUSTMENT		
	<div style="display: flex; justify-content: space-between;"> <div style="width: 48%;"> <ol style="list-style-type: none"> Increase bias current by turning VR201 (L-CH) and VR202 (R-CH). (See fig. 1 on page 4.) Repeat steps 6 and 7 to confirm. (Proceed to steps 8, 9 and 10 if the curve is now within the charted specifications in fig. 15.) If the curve still exceeds the specifications (fig. 15), increase bias current further and repeat steps 6 and 7. </div> <div style="width: 48%;"> <ol style="list-style-type: none"> Reduce bias current by turning VR201 (L-CH) and VR202 (R-CH). Repeat steps 6 and 7 to confirm. (Proceed to steps 8, 9 and 10 if the curve is now within the charted specifications in fig. 15.) If the curve still falls below the charted specifications (fig. 15), reduce bias current further and repeat steps 6 and 7. </div> </div> <ol style="list-style-type: none"> Switch the tape selector to CrO₂, change test tape to QZZCRX, and record 50Hz, 100Hz, 200Hz, 500Hz, 1kHz, 4kHz, 8kHz, 10kHz, 12kHz and 14kHz signals. Then, playback the signals and check if the curve is within the limits shown in the overall frequency response chart for CrO₂ tapes (fig. 20). <div style="text-align: center;">  <p>Overall frequency response chart (CrO₂, Metal)</p> </div> <ol style="list-style-type: none"> Switch the tape selector to Metal, change test tape to QZZCRZ, and record 50Hz, 100Hz, 200Hz, 500Hz, 1kHz, 4kHz, 8kHz, 10kHz and 12.5kHz signals. Then, playback the signals and check if the curve is within the limits shown in the overall frequency response chart for metal tapes (fig. 20). Confirm that bias currents are approximately as follows when the tape selector is set at different positions. <ul style="list-style-type: none"> Read voltage on VTVM and calculate bias current by following formula: $\text{Bias current (A)} = \frac{\text{Value read on VTVM (V)}}{10 (\Omega)}$ <div style="border: 1px solid black; padding: 5px; margin-top: 10px;"> <table style="width: 100%; border-collapse: collapse;"> <tr> <td style="border-right: 1px solid black; padding: 2px;"> around 400μA (Normal position) around 600μA (CrO₂ position) around 1000μA (Metal position) </td> <td style="padding: 2px;">} : measured at TP1 (L-CH) and TP2 (R-CH)</td> </tr> </table> </div> 	around 400μA (Normal position) around 600μA (CrO ₂ position) around 1000μA (Metal position)	} : measured at TP1 (L-CH) and TP2 (R-CH)
around 400μA (Normal position) around 600μA (CrO ₂ position) around 1000μA (Metal position)	} : measured at TP1 (L-CH) and TP2 (R-CH)		
<p>① Overall gain</p> <p>Condition:</p> <ul style="list-style-type: none"> Record/playback mode Normal tape mode Input level controls ... MAX Standard input level; <ul style="list-style-type: none"> MIC -72 ± 3.5 dB LINE IN ... -24 ± 3.5 dB <p>Equipment:</p> <ul style="list-style-type: none"> VTVM AF oscillator ATT Oscilloscope Resistor (600Ω) Test tape (reference blank tape) ... QZZCRA for Normal 	<ol style="list-style-type: none"> Test equipment connection is shown in fig. 21. Place the UNIT into normal tape mode and load the test tape (QZZCRA). Place UNIT into record mode. Supply 1 kHz signal (-24 dB) from AF oscillator, through ATT to LINE IN. Adjust ATT until monitor level at LINE OUT becomes 0.4V. Playback recorded tape, and make sure the value at LINE OUT on VTVM becomes 0.4V. If measured value is not 0.4V, adjust VR5 (L-CH), VR6 (R-CH) (See fig. 2 on page 4). Repeat from step (2). <div style="text-align: right;">  <p>Fig. 21</p> </div>		
<p>② Fluorescent meter</p> <p>Condition:</p> <ul style="list-style-type: none"> Record mode Input level controls ... MAX <p>Equipment:</p> <ul style="list-style-type: none"> VTVM AF oscillator ATT Oscilloscope Resistor (600Ω) 	<ol style="list-style-type: none"> Test equipment connection is shown in fig. 21. As shown in fig. 22, connect the base of Q33 and ground. Supply 1 kHz signal (-24 dB) to the LINE IN jack, then press the record button. Adjust the ATT so that the output level at LINE OUT jack becomes 0.4V (The input level at this condition is termed the standard input level). Adjustment at "-20 dB": <ol style="list-style-type: none"> Adjust the ATT so that input level is -20 dB below standard recording level. Adjust VR7 so that the -20 dB segment lights up in the -20 ± 0.8 dB range (L-CH ONLY) (See fig. 23). <div style="text-align: right;">  <p>Fig. 22</p> </div>		

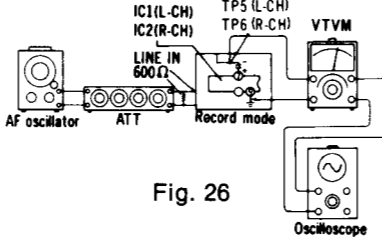
ITEM	MEASUREMENT & ADJUSTMENT
	<p>6. Adjustment at "0dB":</p> <p>A. Adjust the ATT so that the output level at LINE OUT jack becomes 0.4V. (The input level at this condition is termed the standard input level.)</p> <p>B. Adjust VR8 so that the +1 dB segment lights up in the 0±0.2dB range of the standard input level (See fig. 24).</p> <p>7. Repeat twice between steps 5 and 6 above.</p> <p>8. Adjust ATT and check that all segments light up when an input signal level is increased to 10dB higher than the standard input level (See fig. 25).</p> <div style="display: flex; justify-content: space-around;">    </div>
<p>Ⓚ Dolby NR circuit</p> <p>Condition:</p> <ul style="list-style-type: none"> Record mode Dolby NR switch... IN/OUT Input level controls... MAX <p>Equipment:</p> <ul style="list-style-type: none"> VTVM AF oscillator ATT Oscilloscope Resistor (600Ω) 	<p>1. Test equipment connection is shown in fig. 26.</p> <p>2. Place UNIT into record mode, set the Dolby NR switch to OUT position and supply to LINE IN to obtain -34.5dB at TP5 (L-CH), TP6 (R-CH) (frequency 5kHz)</p> <p>3. Confirm that the value at IN position is 8(±2.5)dB greater than the value at OUT position of Dolby NR switch.</p> 

ELECTRICAL PARTS LOCATION

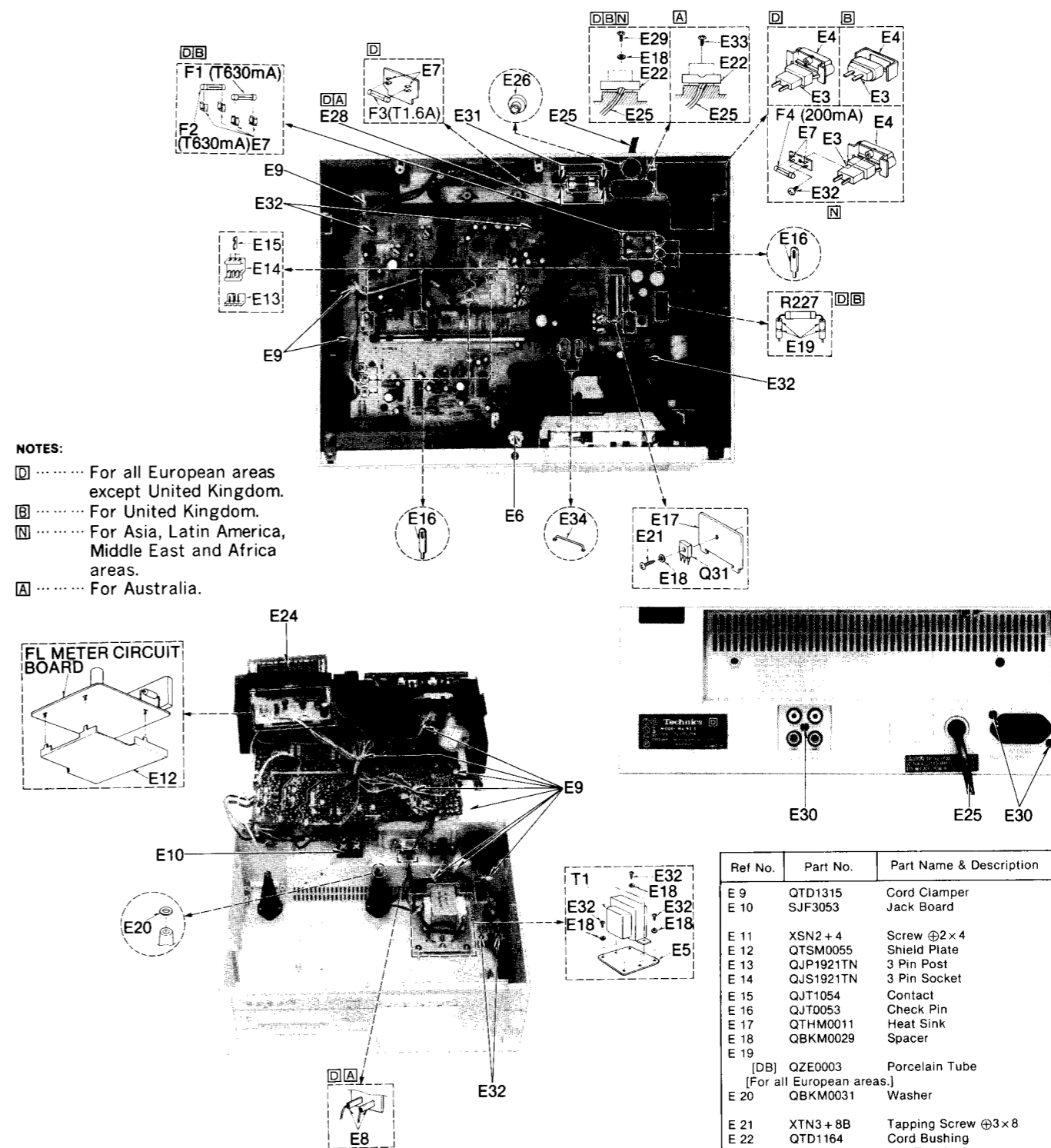
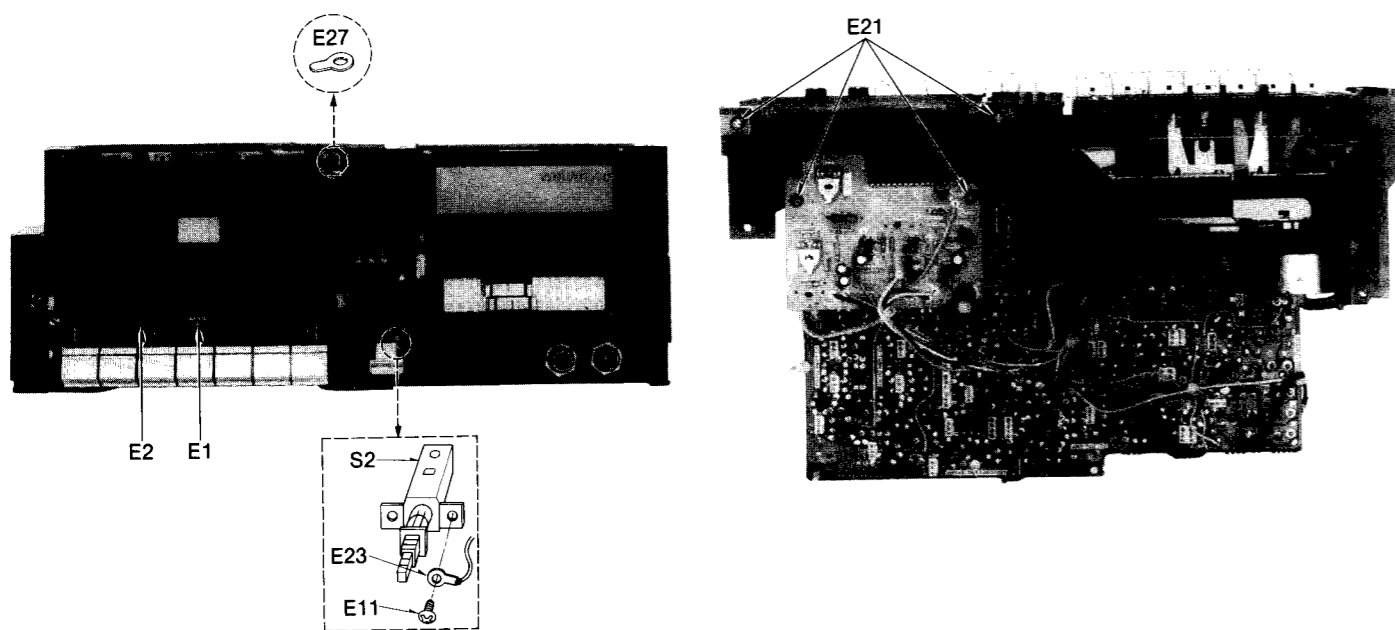

NOTES:

[DB] For all European areas except United Kingdom.

[B] For United Kingdom.

[N] For Asia, Latin America, Middle East and Africa areas.

[A] For Australia.

REPLACEMENT PARTS LIST

Important safety notice
Components identified by Δ mark have special characteristics important for safety.
When replacing any of these components, use only manufacturer's specified parts.

Ref No.	Part No.	Part Name & Description
ELECTRICAL PARTS		
E 1	QWY4122Z	Record/Playback Head
E 2	QWY2138Z	Erase Head
E 3	[B] Δ SJS9225 [For United Kingdom.] [DN] Δ SJS9225	AC Outlet Socket [For all European areas except United Kingdom, Asia, Latin America, Middle East and Africa areas.]
E 4	[B] QMAM0154 [For United Kingdom] Angle [DN] QKJM0086	AC Outlet Socket Holding Angle AC Outlet Socket Holding Plate
E 5	[For all European areas except United Kingdom, Asia, Latin America, Middle East and Africa areas.]	
E 6	QMF0016	Transformer Holding Plate
E 7	[D] Δ QTF1054 [For all European areas except United Kingdom.] [N] Δ QTF1051	Fuse Holder Fuse Holder
E 8	[DA] SJT777	Terminal [For all European areas and Australia.]

Ref No.	Part No.	Part Name & Description
E 9	QTD1315	Cord Clamper
E 10	SJF3053	Jack Board
E 11	XSN2+4	Screw φ2×4
E 12	QTSM0055	Shield Plate
E 13	QJP1921TN	3 Pin Post
E 14	QJS1921TN	3 Pin Socket
E 15	QJT1054	Contact
E 16	QJT0053	Check Pin
E 17	QTHM0011	Heat Sink
E 18	QBKM0029	Spacer
E 19	[DB] QZE0003 [For all European areas.]	Porcelain Tube
E 20	QBKM0031	Washer
E 21	XTN3+8B	Tapping Screw φ3×8
E 22	QTD1164	Cord Bushing
E 23	QTD1317	Lug Terminal
E 24	QSIFL006F	FL Meter
E 25	[B] Δ SJA149 [For United Kingdom.] [A] Δ QFC1208M [For Australia.] [DN] Δ SJA151	AC Power Cord AC Power Cord AC Power Cord
E 26	QBJ1425	Cord Bushing
E 27	QTD1001	Lug Terminal
E 28	[DB] Δ QBK7178 [For all European areas.]	Washer
E 29	XTN3+16B	Tapping Screw φ3×16
E 30	XTB3+10BFZ	Tapping Screw φ3×10
E 31	XTN3+8B	Tapping Screw φ3×8
E 32	XTN3+10B	Tapping Screw φ3×10
E 33	XTB3+12B	Screw φ3×12
E 34	QJT1077	Jumper Wire

RECORD



PLAYBACK



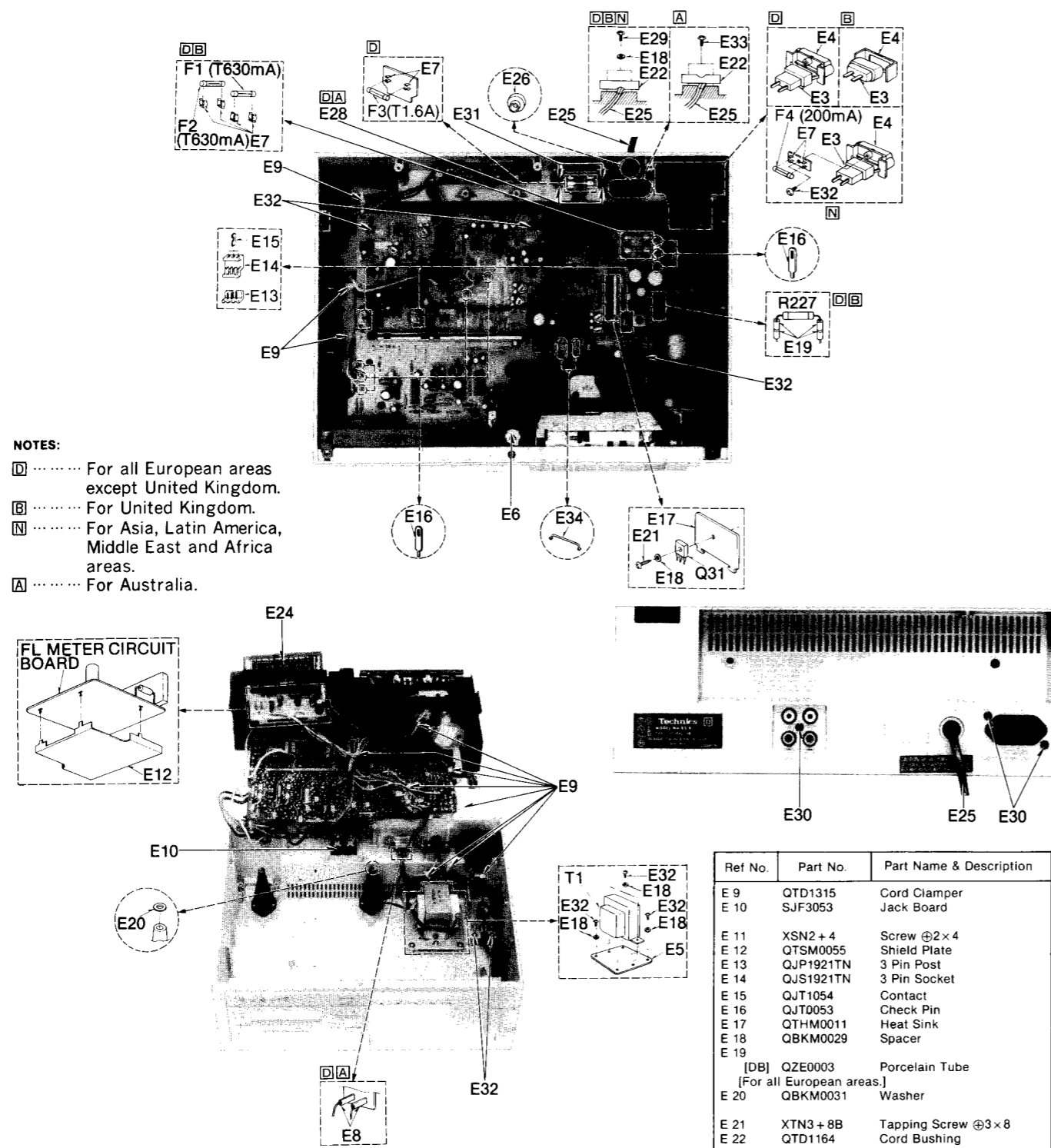
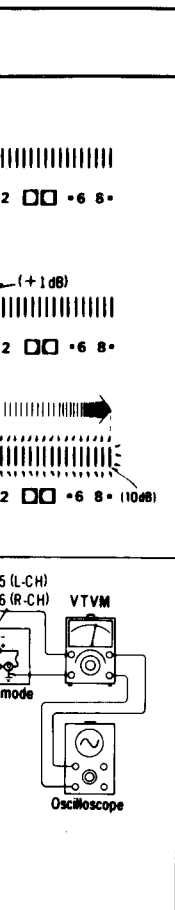

NOTES:
 [D] For all European areas except United Kingdom.
 [B] For United Kingdom.
 [N] For Asia, Latin America, Middle East and Africa areas.
 [A] For Australia.

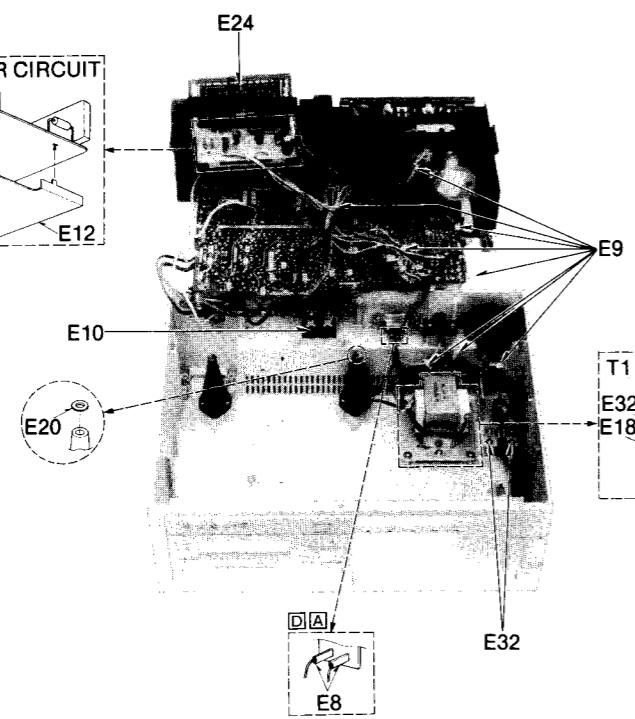
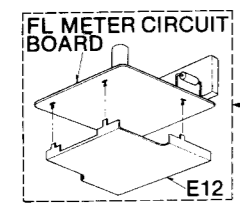

Ref No.	Part No.	Part Name & Description
E 9	QTD1315	Cord Clamper
E 10	SJF3053	Jack Board
E 11	XSN2+4	Screw @2x4
E 12	QTM0055	Shield Plate
E 13	QJP1921TN	3 Pin Post
E 14	QJS1921TN	3 Pin Socket
E 15	QJT1054	Contact
E 16	QJT0053	Check Pin
E 17	QTHM0011	Heat Sink
E 18	QBKM0029	Spacer
E 19	[DB] QZE0003	Porcelain Tube [For all European areas.]
E 20	QBKM0031	Washer
E 21	XTN3+8B	Tapping Screw @3x8
E 22	QTD1164	Cord Bushing
E 23	QTD1317	Lug Terminal
E 24	QSIFL006F	FL Meter
E 25	[B] Δ SJA149	AC Power Cord [For United Kingdom.]
	[A] Δ QFC1208M	AC Power Cord [For Australia.]
	[DN] Δ SJA151	AC Power Cord [For all European areas except United Kingdom, Asia, Latin America, Middle East and Africa areas.]
E 26	QBJ1425	Cord Bushing
E 27	QTD1001	Lug Terminal
E 28	[DB] Δ QBK7178	Washer [For all European areas.]
E 29	XTN3+16B	Tapping Screw @3x16
E 30	XTB3+10BFZ	Tapping Screw @3x10
E 31	XTN3+8B	Tapping Screw @3x8
E 32	XTN3+10B	Tapping Screw @3x10
E 33	XTB3+12B	Screw @3x12
E 34	QJT1077	Jumper Wire

REPLACEMENT PARTS LIST

Important safety notice
 Components identified by Δ mark have special characteristics important for safety.
 When replacing any of these components, use only manufacturer's specified parts.

Ref No.	Part No.	Part Name & Description
ELECTRICAL PARTS		
E 1	QWY4122Z	Record/Playback Head
E 2	QWY2138Z	Erase Head
E 3	[B] Δ SJS9225	AC Outlet Socket [For United Kingdom.]
	[DN] Δ SJS9225	AC Outlet Socket [For all European areas except United Kingdom, Asia, Latin America, Middle East and Africa areas.]
E 4	[B] QMAM0154	AC Outlet Socket Holding Angle [For United Kingdom.]
	[DN] QKJM0086	AC Outlet Socket Holding Plate [For all European areas except United Kingdom, Asia, Latin America, Middle East and Africa areas.]
E 5	QFMF0016	Transformer Holding Plate
E 6	QTM0045	Shield Plate
E 7	[D] Δ QTF1054	Fuse Holder [For all European areas except United Kingdom.]
	[N] Δ QTF1051	Fuse Holder [For Asia, Latin America, Middle East and Africa areas.]
E 8	[DA] SJT777	Terminal [For all European areas and Australia.]

BLOCK DIAGRAM

RECORD SYSTEM (R-CH ONLY)

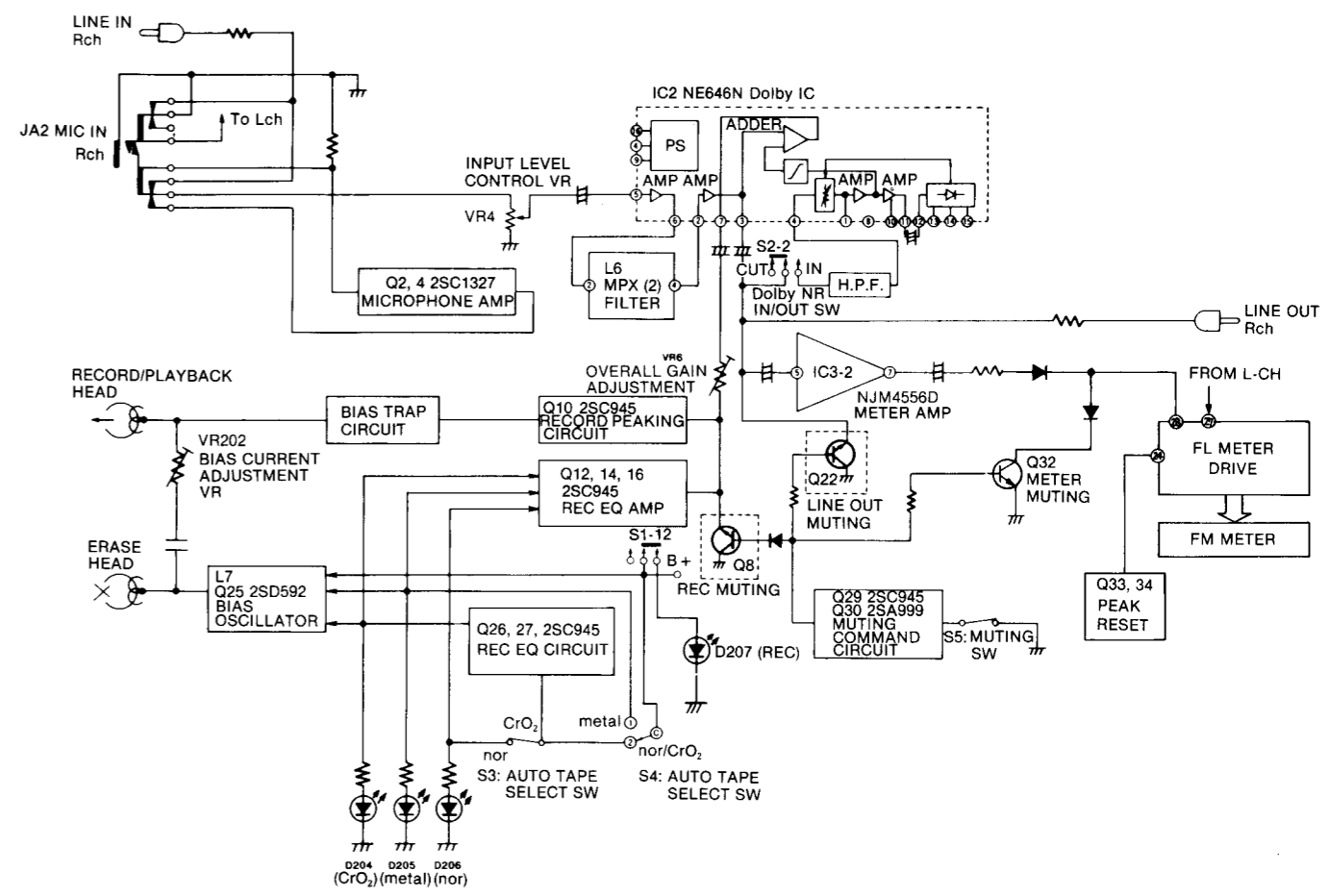

PLAYBACK SYSTEM (L-CH ONLY)

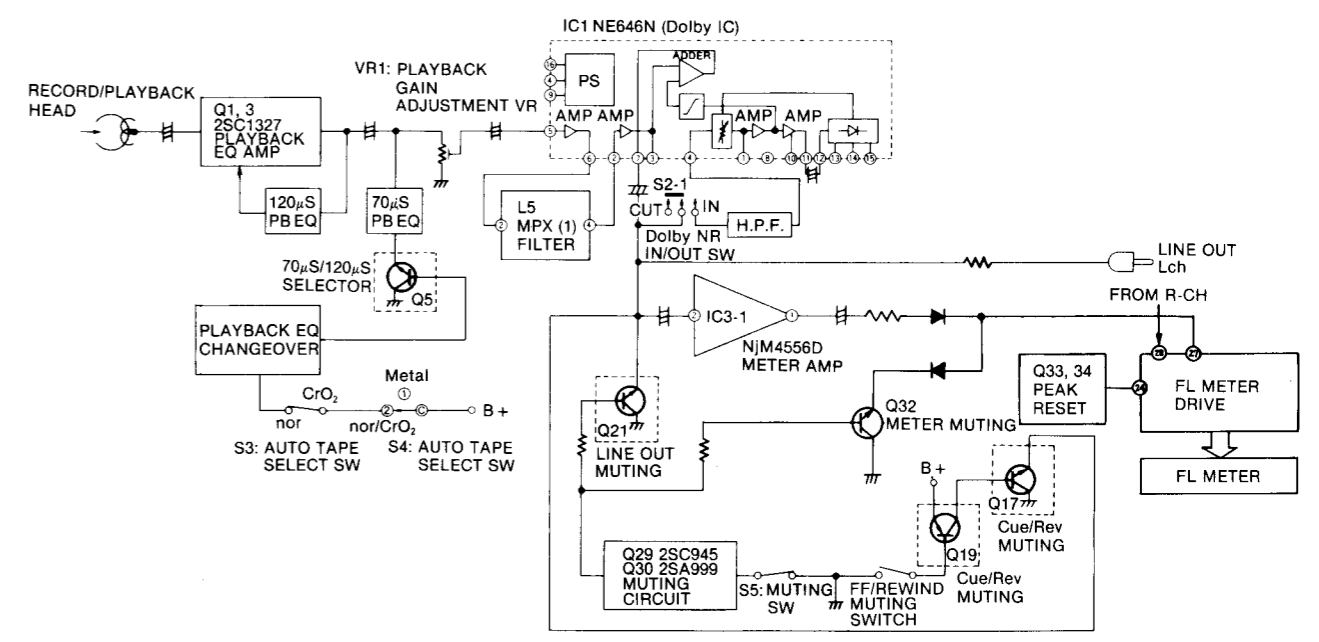

SCHEMATIC DIAGRAM I MAIN CIRCUIT SECTION

II FL METER SECTION

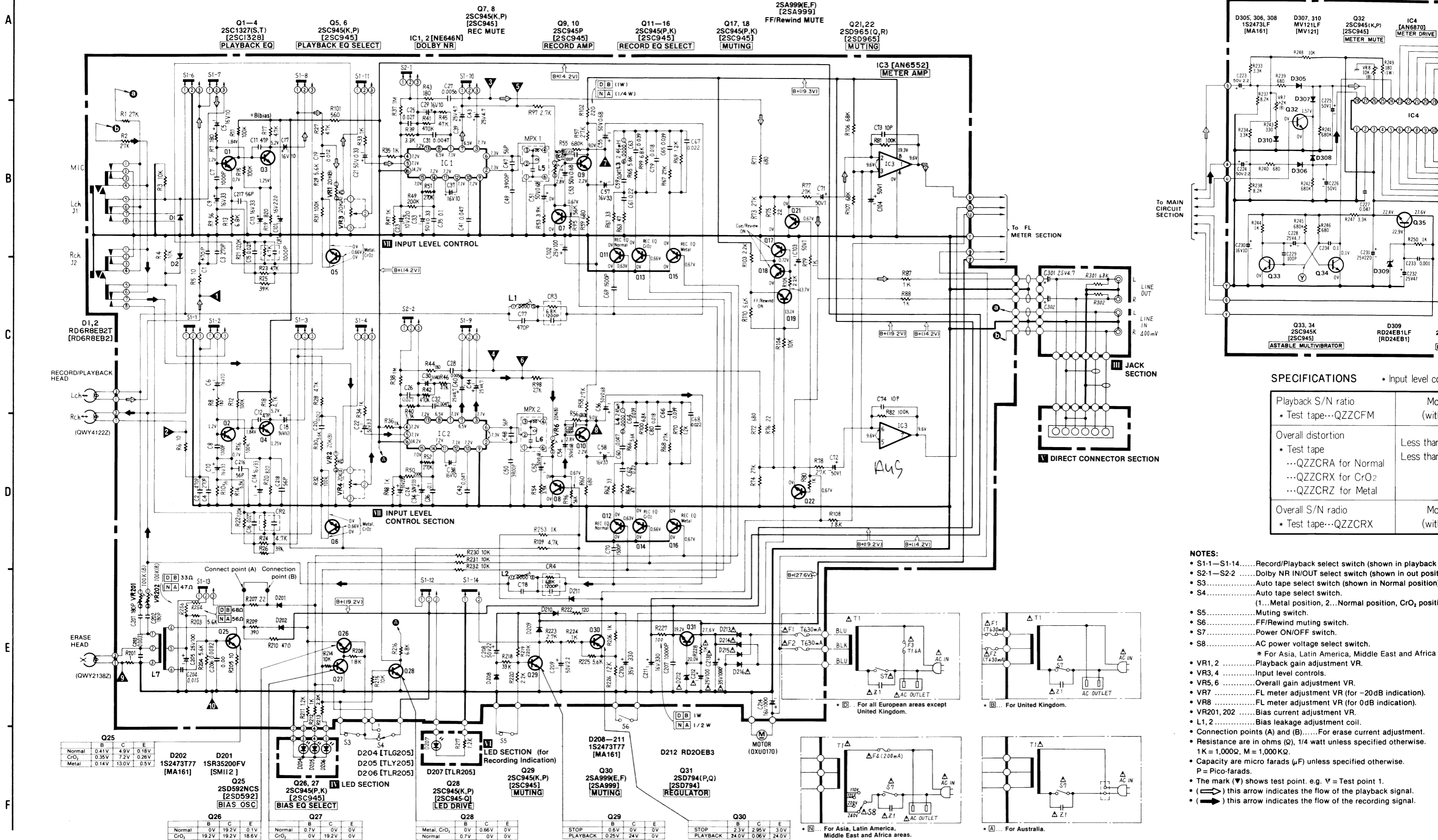

SPECIFICATIONS * Input level control

Playback S/N ratio * Test tape...QZZCFM	More than 40dB (with 20dB indication)
Overall distortion * Test tape ...QZZCRA for Normal ...QZZCRX for CrO ₂ ...QZZCRZ for Metal	Less than 0.5% Less than 0.5%
Overall S/N ratio * Test tape...QZZCRX	More than 40dB (with 20dB indication)

NOTES:

- S1-1—S1-14.....Record/Playback select switch (shown in playback position)
- S2-1—S2-2.....Dolby NR IN/OUT select switch (shown in out position)
- S3.....Auto tape select switch (shown in Normal position)
- S4.....Auto tape select switch.
(1...Metal position, 2...Normal position, CrO₂ position)
- S5.....Muting switch.
- S6.....FF/Rewind muting switch.
- S7.....Power ON/OFF switch.
- S8.....AC power voltage select switch.
* For Asia, Latin America, Middle East and Africa areas
- VR1, 2.....Playback gain adjustment VR.
- VR3, 4.....Input level controls.
- VR5, 6.....Overall gain adjustment VR.
- VR7.....FL meter adjustment VR (for -20dB indication).
- VR8.....FL meter adjustment VR (for 0dB indication).
- VR201, 202.....Bias current adjustment VR.
- L1, 2.....Bias leakage adjustment coil.
- Connection points (A) and (B).....For erase current adjustment.
- Resistance are in ohms (Ω), 1/4 watt unless specified otherwise.
1K = 1,000Ω, M = 1,000KΩ.
- Capacity are micro farads (μF) unless specified otherwise.
P = Pico-farads.
- The mark (▽) shows test point. e.g. ▽ = Test point 1.
- (→) this arrow indicates the flow of the playback signal.
- (→) this arrow indicates the flow of the recording signal.

Q25	B	C	E
Normal	0.41V	4.9V	0.18V
CrO ₂	0.35V	7.2V	0.26V
Metal	0.14V	13.0V	0.5V

D202	B	C	E
1S2473T77 [MA161]	0.7V	0.7V	0.7V
D201 1SR35200FV [SM112]	0.7V	0.7V	0.7V

Q26, 27	B	C	E
2SC945(P,K) [2SC945]	0.7V	0.7V	0.7V
Q26 2SD592NCS [2SD592] [BIAS OSC]	0.7V	0.7V	0.7V

Q27	B	C	E
Normal	0.7V	0.7V	0.7V
CrO ₂	0.7V	0.7V	0.7V

Q28	B	C	E
Metal, CrO ₂	0.7V	0.66V	0.7V
Normal	0.7V	0.7V	0.7V

Q29	B	C	E
STOP	0.6V	0.7V	0.7V
PLAYBACK	0.25V	24V	0.7V

Q30	B	C	E
STOP	2.3V	2.95V	3.0V
PLAYBACK	24.0V	0.06V	24.0V

* [N]... For Asia, Latin America, Middle East and Africa areas.

FL METER SECTION

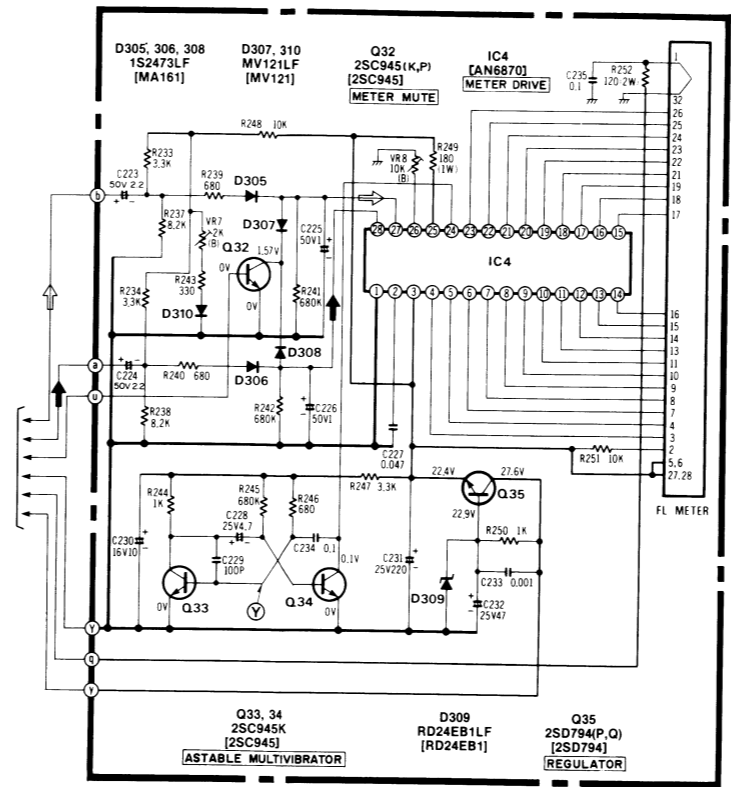
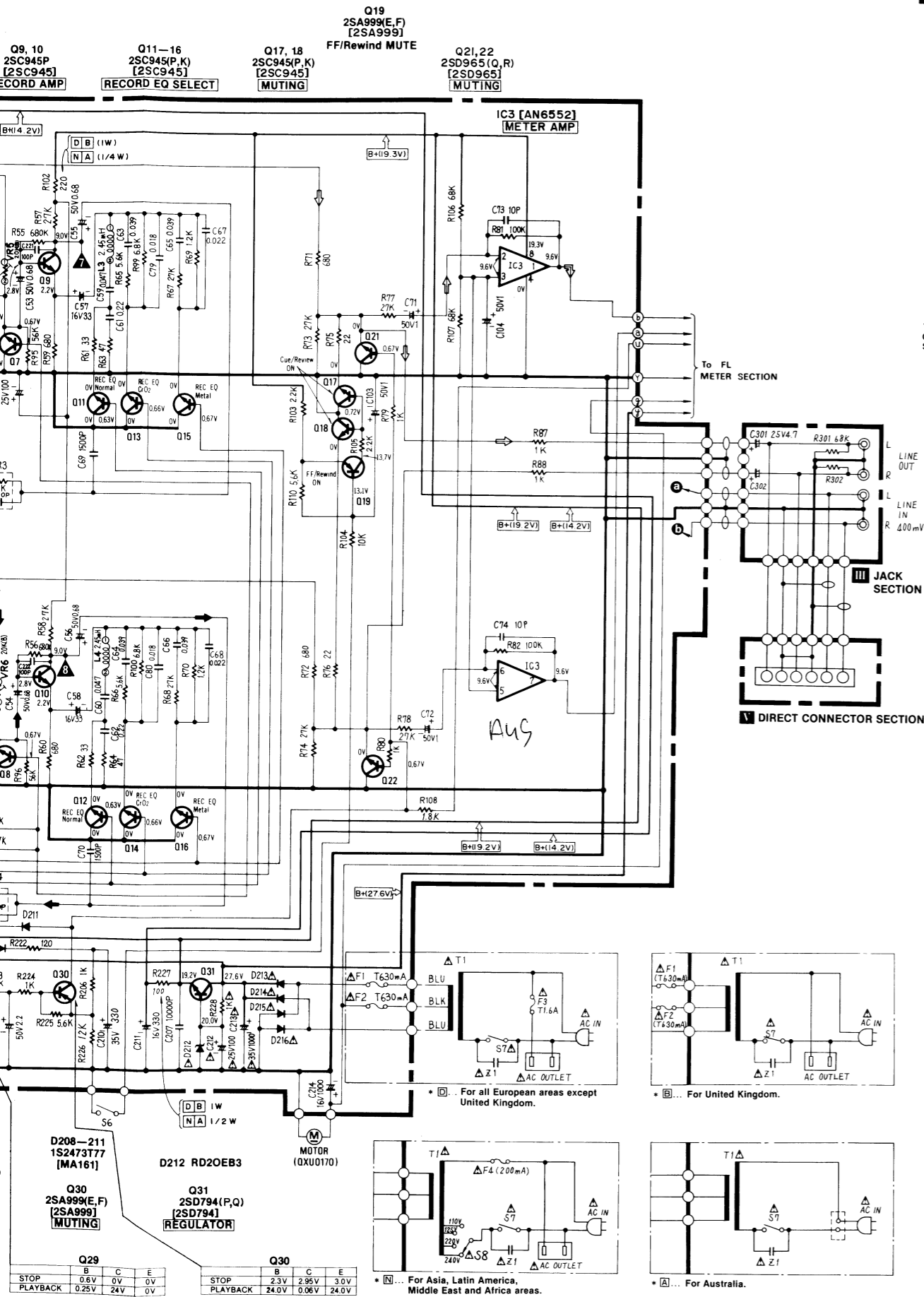

SPECIFICATIONS

Playback S/N ratio • Test tape...QZZCFM	More than 45dB (without NAB filter)
Overall distortion • Test tape ...QZZCRA for Normal ...QZZCRX for CrO ₂ ...QZZCRZ for Metal	Less than 3% (Normal) Less than 3.5% (CrO ₂ , Metal)
Overall S/N ratio • Test tape...QZZCRX	More than 46dB (without NAB filter)

- NOTES:**
- S1-1-S1-14.....Record/Playback select switch (shown in playback position).
 - S2-1-S2-2.....Dolby NR IN/OUT select switch (shown in out position).
 - S3.....Auto tape select switch (shown in Normal position).
 - S4.....Auto tape select switch.
(1...Metal position, 2...Normal position, CrO₂ position)
 - S5.....Muting switch.
 - S6.....FF/Rewind muting switch.
 - S7.....Power ON/OFF switch.
 - S8.....AC power voltage select switch.
* For Asia, Latin America, Middle East and Africa areas.
 - VR1, 2.....Playback gain adjustment VR.
 - VR3, 4.....Input level controls.
 - VR5, 6.....Overall gain adjustment VR.
 - VR7.....FL meter adjustment VR (for -20dB indication).
 - VR8.....FL meter adjustment VR (for 0dB indication).
 - VR201, 202.....Bias current adjustment VR.
 - L1, 2.....Bias leakage adjustment coil.
 - Connection points (A) and (B).....For erase current adjustment.
 - Resistance are in ohms (Ω), 1/4 watt unless specified otherwise.
1K = 1,000Ω, M = 1,000KΩ.
 - Capacity are micro farads (μF) unless specified otherwise.
P = Pico-farads.
 - The mark (▼) shows test point. e.g. ▼ = Test point 1.
 - (→) this arrow indicates the flow of the playback signal.
 - (→) this arrow indicates the flow of the recording signal.

EQUIVALENT CIRCUIT

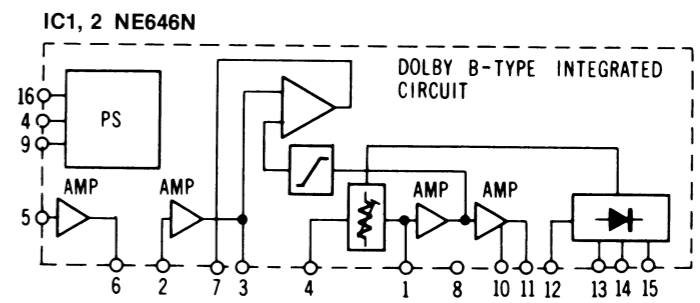

IC4 AN6870

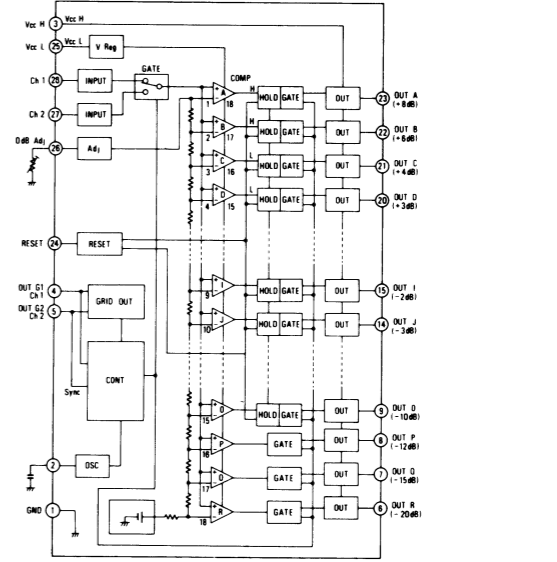

TERMINATIONS

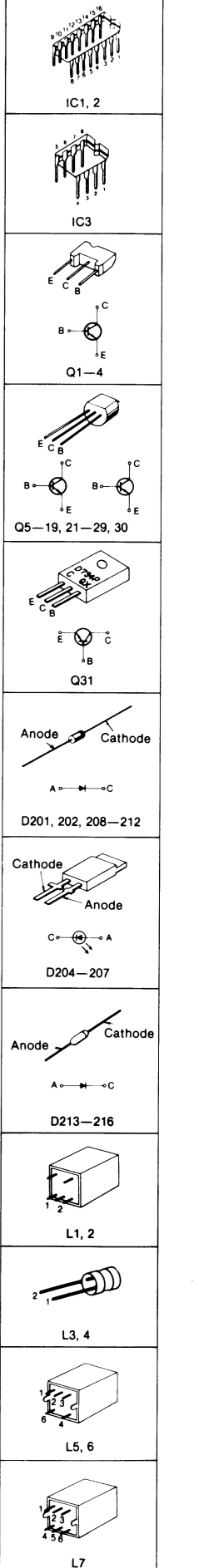

• This schematic diagram may be modified at any time with the development of new technology.

CIRCUIT BOARDS AND WIRING CONNECTION DIAGRAM

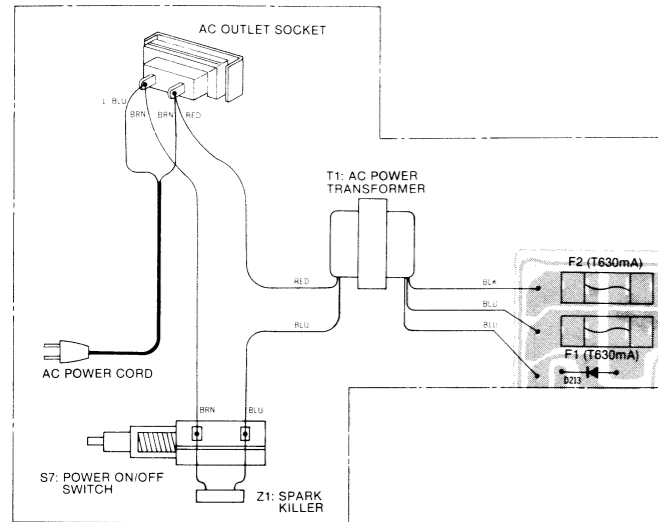

• [UK] ... For United Kingdom

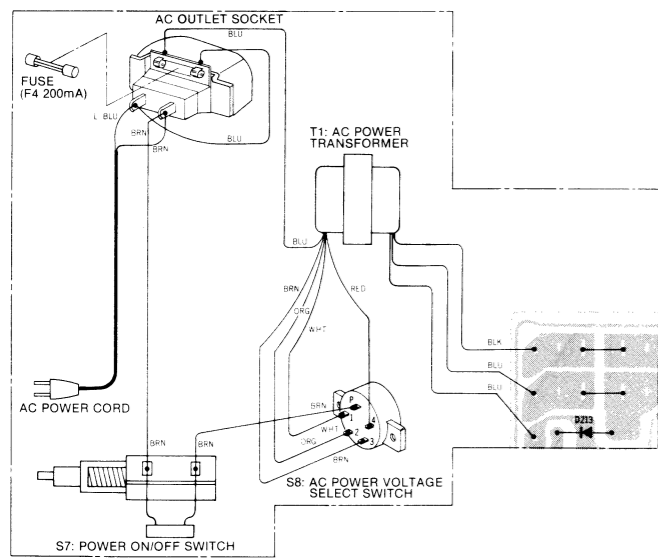

• [NA] ... For Asia, Latin America, Middle East and Africa areas

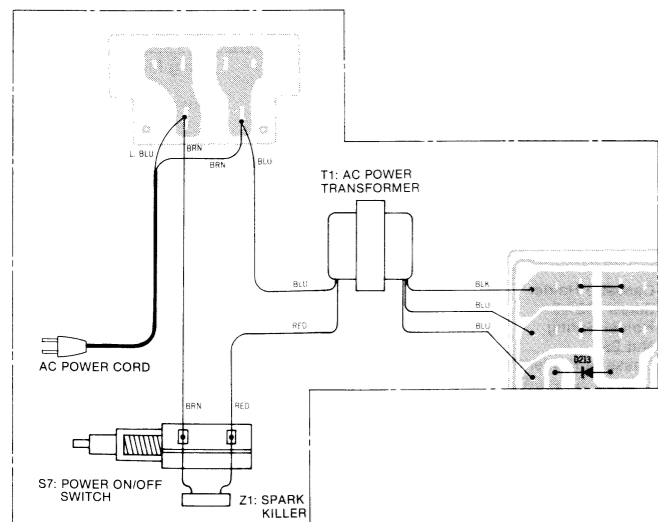

• [AU] ... For Australia

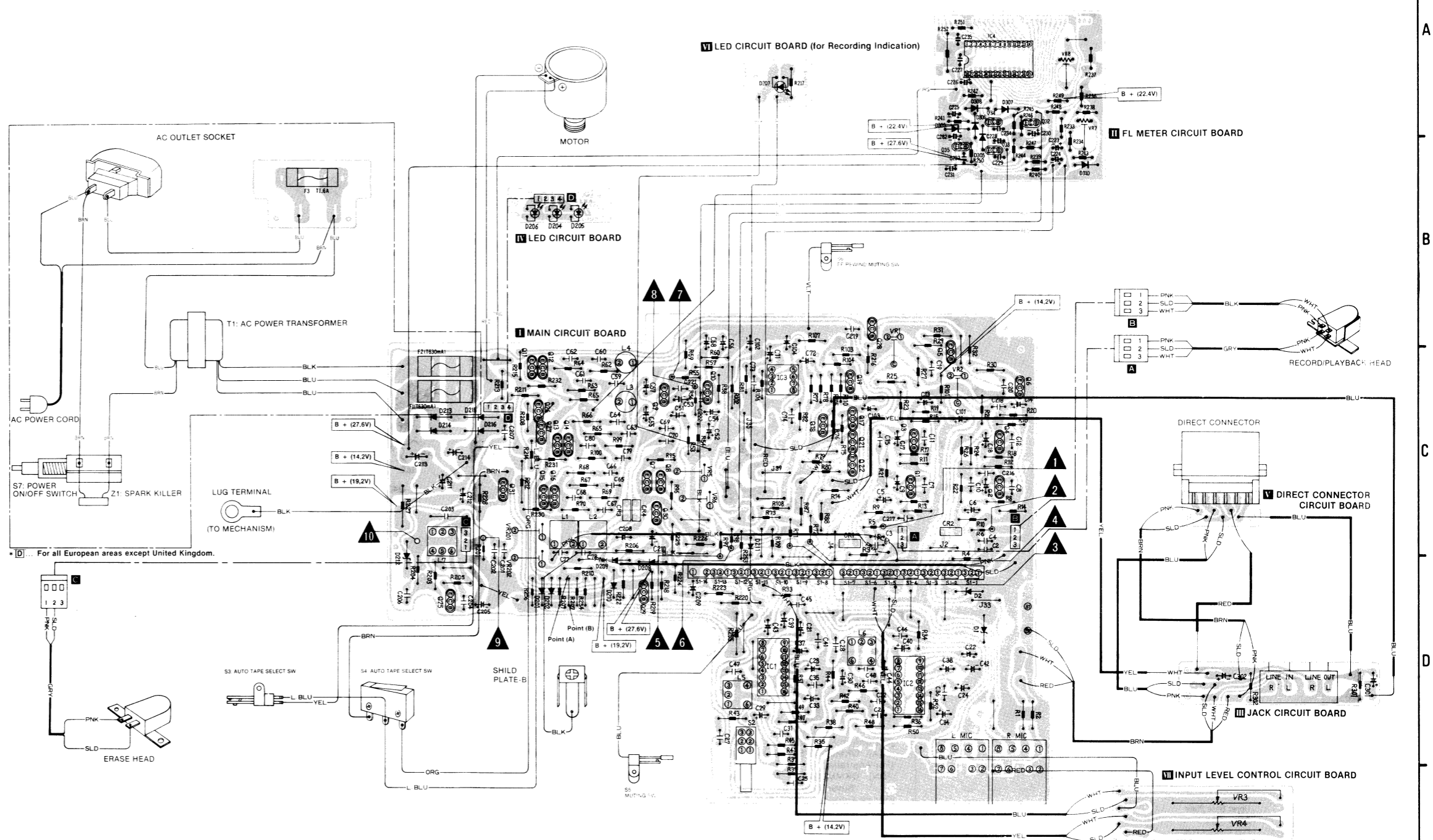

NOTES:

- BLKBlack
- BLUBlue
- BRNBrown
- GRYGray
- GRNGreen
- L. BLULight Blue
- NILNo Color Mark
- ORGOrange
- PNKPink
- REDRed
- SLDShield Wire
- VLTViolet
- WHTWhite
- YELYellow

NOTES:

- The circuit shown in [shaded area] on the conductor indicates printed circuit on the back side of the printed circuit board.
- Values indicated in [shaded area] are DC voltage between the ground and electrical parts.
- All voltage values shown in circuitry are under no signal condition. Unless otherwise specified, voltage measurement conditions are that tape travel is at STOP, tape mode at NORMAL, and Dolby NR switch at OFF.
 NormalVoltage at normal tape mode
 Cue/review OFFVoltage at modes other than cue/review
 StopVoltage at stop mode
 PlaybackVoltage at playback mode
 For measurement, use VTVM.

• The supply parts number is described alone in the replacement parts list.

• This circuit board diagram may be modified at any time with the development of new technology.

IC ₁ : [NE646N]	
1	7.1V
2	7.3V
3	7.7V
4	7.2V
5	7.1V
6	7.3V
7	6.5V
8	6.5V

IC ₂	
1	9.6V
2	9.6V
3	9.6V
4	0V
5	9.6V
6	9.6V
7	9.6V
8	19.3V

Q _{1,2} : [2SC1328]	
B	1.2V
C	1.84V
E	0.7V

Q _{3,4} : [2SC1328]	
B	1.84V
C	5.2V
E	1.25V

Q _{5,6} : [2SC945]	
B	0.67V
C	0V
E	0V

Q _{7,8} : [2SC945]	
B	2.8V
C	9.0V
E	2.2V

Q _{9,10} : [2SC945]	
B	0.67V
C	0V
E	0V

Q _{11,12} : [2SC945]	
B	0.63V
C	0V
E	0V

Q _{13,14} : [2SC945]	
B	0.66V
C	0V
E	0V

Q _{15,16} : [2SC945]	
B	0.67V
C	0V
E	0V

Q _{17,18} : [2SC945]	
B	0.41V
C	4.9V
E	0.18V

Q _{19,20} : [2SA999]	
B	13.1V
C	13.7V
E	13.7V

Q _{21,22} : [2SD965]	
B	0.67V
C	0V
E	0V

Q ₂₃ : [2SD592]	
B	0.41V
C	4.9V
E	0.18V

Q ₂₄ : [2SC945]	
B	0.67V
C	0V
E	0V

Q ₂₅ : [2SC945]	
B	0.7V
C	0V
E	0V

Q ₂₆ : [2SC945]	
B	19.2V
C	19.2V
E	0.1V

Q ₂₇ : [2SC945]	
B	0.7V
C	0V
E	0V

Q ₂₈ : [2SC999]	
B	2.3V
C	2.95V
E	3.0V

Q ₂₉ : [2SC945]	
B	0.6V
C	0V
E	0V

Q ₃₀ : [2SC945]	
B	0.25V
C	24V
E	0V

Q ₃₁ : [2SD794]	
B	20V
C	26.3V
E	19.2V

Q ₃₂ : [2SC945]	
B	0V
C	1.57V
E	0V

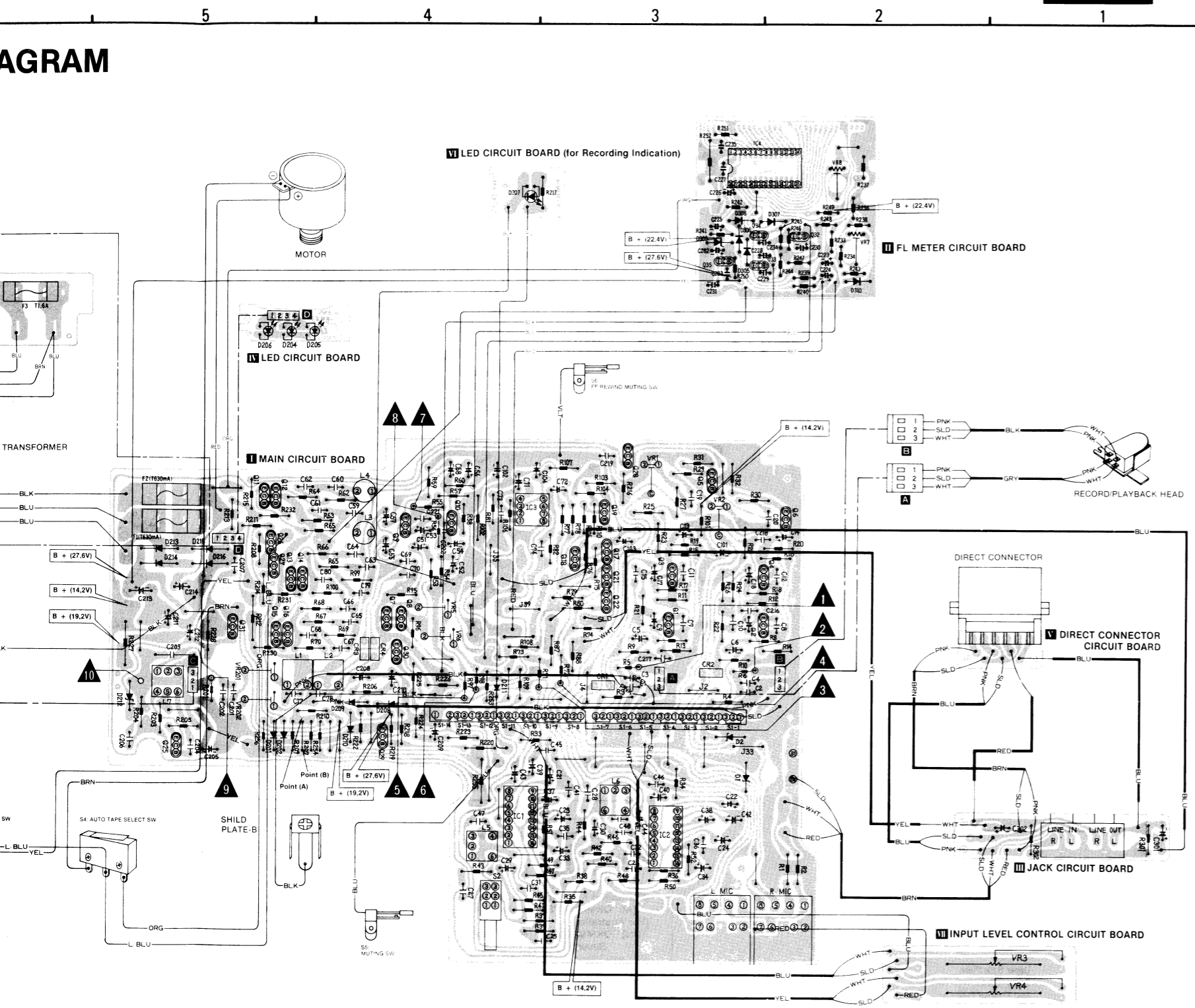

on the conductor indicates printed circuit on printed circuit board.
 are DC voltage between the ground and
 in circuitry are under no signal condition.
 fied, voltage measurement conditions are that tape travel is at STOP, L, and Dolby NR switch at OFF.
 voltage at normal tape mode
 voltage at modes other than cue/review
 voltage at stop mode
 voltage at playback mode
 TVM.
 ber is described alone in the replacement parts list.
 d diagram may be modified at any time
 ment of new technology.

IC ₁₋₂ [NE646N]		Q ₁₋₂ [2SC1328]		Q ₇₋₈ [2SC945]		Q ₁₃₋₁₄ [2SC945]		Q ₁₉ [2SA999]		Q ₂₈ [2SC945]		Q ₂₉ [2SC945]		Q ₃₂ [2SC945]	
1	7.1V	9	0V	B	1.2V	B	0.67V	B	0.66V	B	0V	B	0.6V	B	0V
2	7.3V	10	7.2V	C	1.84V	C	0V	C	13.1V	C	19.2V	C	19.2V	C	0V
3	7.7V	11	7.2V	E	0.7V	E	0V	E	13.7V	E	19.2V	E	0.1V	E	1.57V
4	7.2V	12	7.1V												
5	7.1V	13	7.2V												
6	7.3V	14	7.2V												
7	6.5V	15	7.0V												
8	6.5V	16	14.2V												

IC ₃		Q ₄₋₆ [2SC1328]		Q ₉₋₁₀ [2SC945]		Q ₁₅₋₁₆ [2SC945]		Q ₂₁₋₂₂ [2SD965]		Q ₂₇ [2SC945]		Q ₂₈ [2SC999]		Q ₃₄ [2SC945]		Q ₃₅ [2SC945]	
1	9.6V	B	1.84V	B	2.8V	B	0.67V	B	0.67V	B	0.6V	B	2.3V	B	—	B	—
2	9.6V	C	5.2V	C	9.0V	C	0V	C	0V	C	0V	C	2.95V	C	—	C	—
3	9.6V	E	1.25V	E	2.2V	E	0V	E	0V	E	0V	E	3.0V	E	0V	E	0V
4	0V																
5	9.6V																
6	9.6V																
7	9.6V																
8	19.3V																

NOTES: RESISTORS
 ERD.....Carbon
 ERG.....Metal-oxide
 ERS.....Metal-oxide
 ERO.....Metal-film
 ERX.....Metal-film
 ERQ.....Fuse type metallic
 ERC.....Solid
 ERF.....Cement

CAPACITORS
 ECBA.....Ceramic
 ECGD.....Ceramic
 ECKD.....Ceramic
 ECCD.....Ceramic
 ECFD.....Ceramic
 ECQM.....Polyester film
 ECQE.....Polyester film
 ECQF.....Polypropylene
 ECEQ.....Electrolytic
 ECEDN.....Non polar electrolytic
 ECQS.....Polystyrene
 ECSQ.....Tantalum
 QCS.....Tantalum

REPLACEMENT PARTS LIST

Important safety notice
 Components identified by Δ mark have special characteristics important for safety.
 When replacing any of these components, use only manufacturer's specified parts.

Ref No.	Part No.	Ref No.	Part No.	Ref No.	Part No.	Ref No.	Part No.	Ref No.	Part No.
RESISTORS									
R 1, 2	ERD25TJ273	R 220	ERD25FJ222	R 49, 50	ECQP1392JZ	D 210	SM112	D 309	RD24EB1
R 3, 4	ERD25FJ103	R 222 [DB]	ERQ14AJ121	R 51, 52, 53, 54, 55, 56	ERQ14AJ121	D 211	MA161	D 310	MV121
R 5, 6	ERD25FJ100	[For all European areas.]		C 57, 58	ECEA1CS330	D 212	Δ RD20EB3	INTEGRATED CIRCUITS	
R 7, 8	ERD25FJ181	[AN] ERD25TJ121		C 59, 60	ECQM1H473JZ	D 213, 214, 215, 216	Δ SM112	IC 1, 2	NE646N
R 9, 10	ERD25FJ560	[For Australia, Asia, Latin America, Middle East and Africa areas.]		C 61, 62	ECQV05224JZ	D 305, 306	MA161	IC 3	AN6552
R 11, 12	ERD25TJ104	R 223	ERD25FJ272	C 63, 64, 65, 66	ECQM1H393JZ	D 307	MV121	IC 4	AN6870N
R 13, 14	ERD25FJ682	R 224	ERD25FJ102	C 67, 68	ECQM1H223JZ	D 308	MA161		
R 15, 16	ERD25TJ104	R 225	ERD25FJ562	C 69, 70	ECKD1H152KB				
R 17, 18	ERD25FJ472	R 226	ERD25TJ123	C 71, 72	ECEA50Z1				
R 19, 20	ERD25FJ821	R 227 [DB]	ERG1ANJ101	C 73, 74	ECDD1H100J				
R 21, 22	ERD25TJ124	[AN] ERC12GJ101		C 77, 78	ECQP1471JZ				
R 23, 24	ERD25FJ472	[For Australia, Asia, Latin America, Middle East and Africa areas.]		C 79, 80	ECQM1H183JZ				
R 25, 26	ERD25TJ393	R 228	ERD25FJ102	C 101	ECEA1CS221				
R 27, 28	ERD25FJ472	R 229, 240	ERD25FJ681	C 102	ECEA1ES101				
R 29, 30	ERD25FJ562	R 241, 242	ERD25TJ684	C 103	ECEA50Z3R3				
R 31, 32	ERD25TJ104	R 243	ERD25FJ331	C 104	ECEA50Z1				
R 33, 34, 35, 36	ERD25FJ102	R 244	ERD25FJ102	C 201, 202	ECKD1H181KB				
R 37, 38	ERD25TJ105	R 245, 246	ERD25TJ684	C 203	ECQF6332KZ				
R 39, 40	ERD25FJ332	R 247	ERD25FJ332	C 204	ECQM1H153JZ				
R 41, 42	ERD25TJ474	R 248	ERD25FJ103	C 205	ECEA1ES101				
R 43, 44	ERD25FJ181	R 249	ERG1ANJ181	C 206	ECQM1H822JZ				
R 45, 46	ERD25TJ473	R 250	ERD25FJ102	C 207	ECKD1H103KF				
R 47, 48	ERD25FJ102	R 251	ERD25FJ103	C 208	ECEA1JS220				
R 49, 50	ERO25CKG2003	R 252	ERG2ANJ121	C 209	ECEA50Z2R2				
R 51, 52	ERD25TJ274	R 253	ERD25FJ102	C 210	ECEA1VS331				
R 53, 54	ERD25FJ392	R 254 [DB]	ERDFCG680	C 211	ECEA1CS331				
R 55, 56	ERD25TJ684	[For all European areas.]		C 212	Δ ECEA1ES101				
R 57, 58	ERD25FJ272	[AN] ERD25FJ560		C 213	Δ ECEA1VS102				
R 59, 60	ERD25FJ681	[For Australia, Asia, Latin America, Middle East and Africa areas.]		C 214	ECEA1CS102				
R 61, 62	ERD25FJ330	[For all European areas.]		C 216, 217, 218	ECCD1H560J				
R 63, 64	ERD25FJ470	[AN] ERD25FJ560		C 221, 222	ECDD1H101K				
R 65, 66	ERD25FJ562	[For Australia, Asia, Latin America, Middle East and Africa areas.]		C 223, 224	ECEA50Z2R2				
R 67, 68	ERD25FJ272	[AN] ERD25FJ560		C 225, 226	ECEA50Z1				
R 69, 70	ERD25FJ122	[For Australia, Asia, Latin America, Middle East and Africa areas.]		C 227	ECQM1H473JZ				
R 71, 72	ERD25FJ681	[For all European areas.]		C 228	ECEA25Z4R7				
R 73, 74	ERD25TJ273	[AN] ERD25FJ470		C 229	ECCD1H101K				
R 75, 76	ERD25FJ220	[For all European areas.]		C 230	ECEA1HS100				
R 77, 78	ERO25CKG2702	[AN] ERD25FJ470		C 231	ECEA1ES221				
R 79, 80	ERD25FJ102	[For Australia, Asia, Latin America, Middle East and Africa areas.]		C 232	ECEA1ES470				
R 81, 82	ERO25CKG1003	[For Australia, Asia, Latin America, Middle East and Africa areas.]		C 233	ECKD1H102KB				
R 83, 84	ERD25FJ103	R 301, 302	ERD25TJ683	C 234, 235	ECQV05104JZ				
R 85, 86	ERD25FJ562	R 301, 302	ERD25TJ683	C 301, 302	ECEA25Z4R7				
R 87, 88	ERD25FJ102								
R 95, 96	ERD25TJ563								
R 97, 98	ERD25FJ272								
R 99, 100	ERD25FJ682								
R 101	ERD25FJ561								
R 102 [DB]	ERG1ANJ221								
[For all European areas.]									
[AN] ERD25FJ221									
[For Australia, Asia, Latin America, Middle East and Africa areas.]									
R 103	ERD25FJ222								
R 104	ERD25FJ103								
R 105	ERD25FJ222								
R 106, 107	ERD25TJ683								
R 108	ERD25FJ182								
R 109	ERD25FJ472								
R 110	ERD25FJ562								
R 201	ERD25FJ180								
R 203, 204	ERD25FJ562								
R 205	ERD25FJ100								
R 206	ERD25FJ102								
R 207	ERD25FJ220								
R 208	ERD25FJ182								
R 209	ERD25FJ391								
R 210	ERD25FJ471								
R 211	ERD25FJ122								
R 212	ERD50FJ102								
R 213	ERD25FJ222								
R 214, 215	ERD25FJ103								
R 216	ERD25FJ682								
R 217	ERD25FJ122								
R 218	ERD25TJ333								
R 219	ERD25TJ224								

MECHANICAL PARTS LOCATION

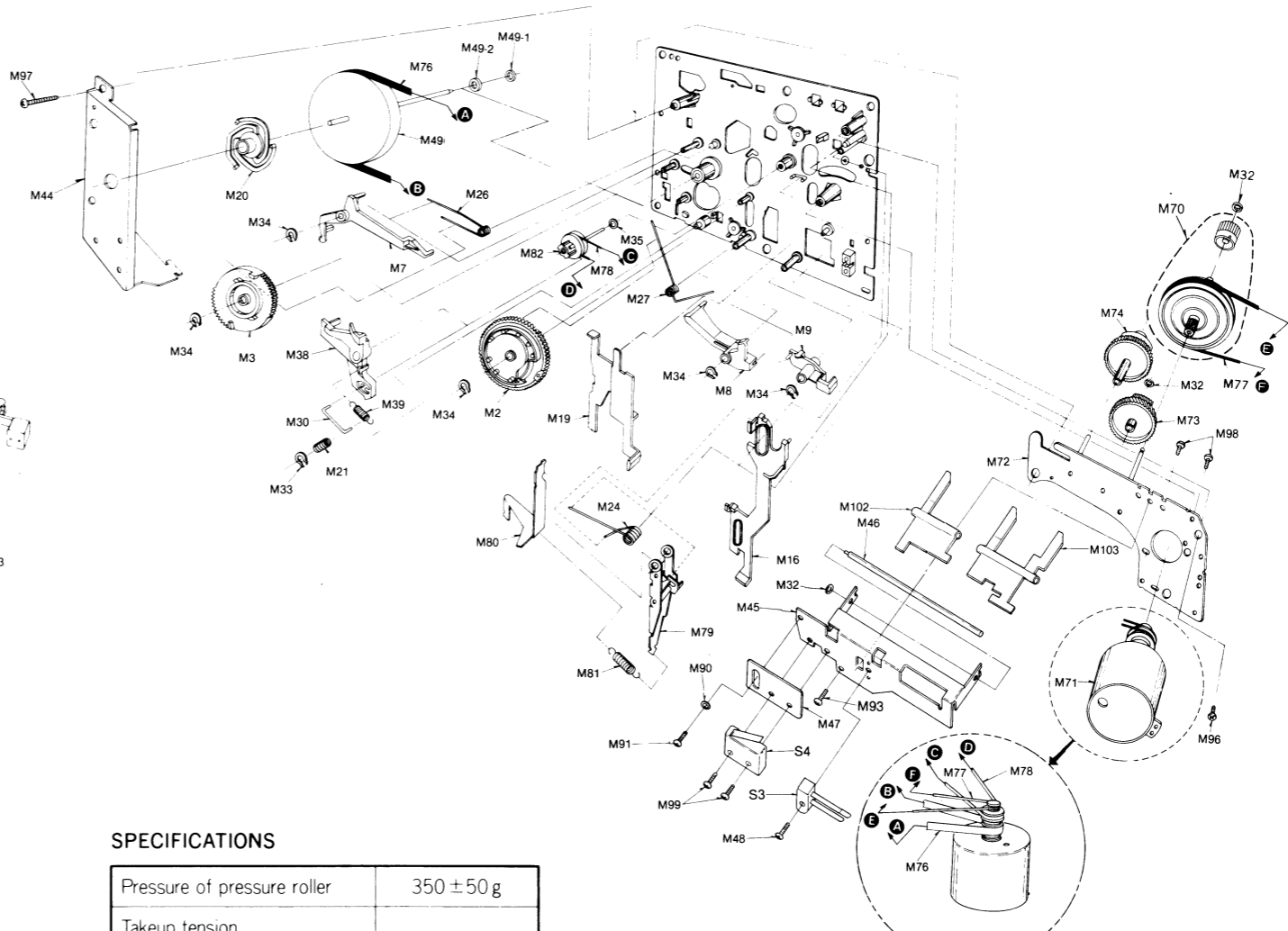
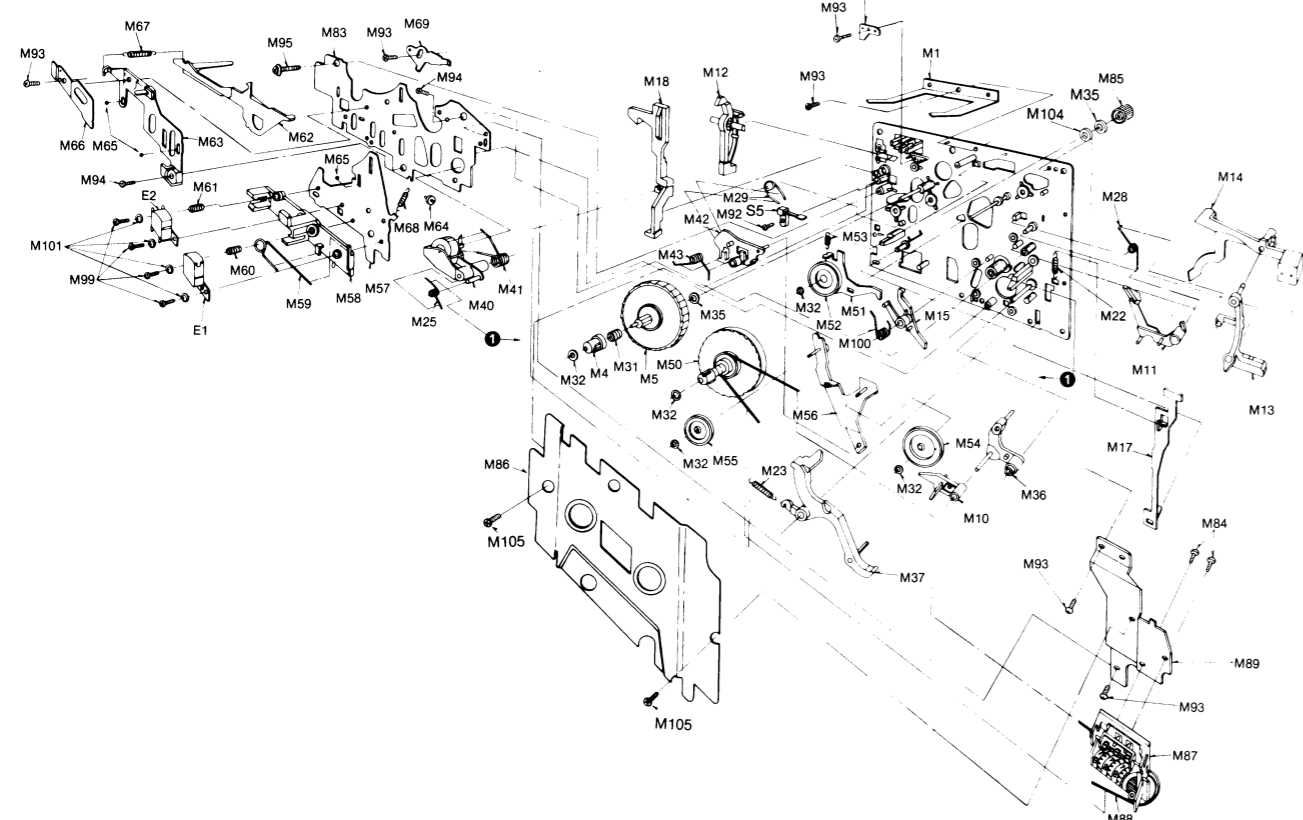

When servicing this mechanism unit, refer to the disassembly notes and assembly instructions described in the service manuals of RS-M51, RS-M13, RS-M14 and RS-M04 (RS-M24 mechanism series).

SPECIFICATIONS

Pressure of pressure roller	350 ± 50 g
Takeup tension * Use cassette torque meter ... QZZSRKCT	45 ± 15 g-cm
Wow and flutter: (JIS) * Use test tape ... QZZCWAT	Less than 0.06% (WRMS)

REPLACEMENT PARTS LIST

Ref. No.	Part No.	Part Name & Description	Ref. No.	Part No.	Part Name & Description	Ref. No.	Part No.	Part Name & Description	Ref. No.	Part No.	Part Name & Description
MECHANICAL PARTS											
M1	QBP1874	Cassette Pressure Spring	M27	QBN1802	Main Gear Spring	M52	QX10111	Takeup Idler Assembly	M80	QML3580	Record/Playback Selection Lever
M2	QDG1201	Main Gear	M28	QBN1746	Auto-Stop Lever Spring	M53	QBT1893	Takeup Idler Spring	M81	QBT1895	Record/Playback Selection Lever Spring
M3	QDG1202	Sub Gear	M29	QBN1747	Connection Spring	M54	QX10113	Fast Forward Idler Assembly	M82	QXP0607	Fast Forward Connection Pulley Assembly
M4	QMB1336	Supply Reel Table Hub	M30	QBS1128	Lock Pin	M55	QX10112	Rewind Idler Assembly	M83	QMK1838	Upper Base Plate
M5	QDR1139	Supply Reel Table	M31	QBC1372	Reel Table Spring	M56	QXL1383	Fast Forward Arm Assembly	M84	XSN3+5S	Screw ±3×5
M6	QMF2118	Fast Forward Arm Bracket	M32	QBW2008	Poly Washer 2φ	M57	QMK1840	Head Base Plate	M85	QDP1828	Fast Forward Pulley
M7	QML3581	Sub Control Lever	M33	XUB4FT	Stop Ring 4φ	M58	QMZ1241	Head Spacer	M86	QXH0357H	Chassis Cover Assembly
M8	QML3583	Main Control Lever	M34	XUB3FT	Stop Ring 3φ	M59	QBN1740	Head Pressure Spring	M87	QXC0079	Tape Counter
M9	QML3584	Record Reverse Lever	M35	QBW2012	Poly Washer	M60	QBC1278	Head Spring (for Record/Playback Head)	M88	QDB0207	Counter Belt
M10	QML3586	Head Base Plate Lift Lever	M36	QXL1354	Sub Lever Assembly	M61	QBCA0008	Head Spring (for Erase Head)	M89	QMAM0150	Counter Angle
M11	QML3594	Auto-Stop Release Arm	M37	QXL1355	Main Lever Assembly	M62	QML3591	Brake Arm	M90	XWC26B	Washer 2.6φ
M12	QML3603	Erase Safety Lever	M38	QML3582	Pause Lock Lever	M63	QMZ1240	Sub Head Base Plate	M91	XSN2+6	Screw ±2.6×6
M13	QML3604	Auto-Stop Driving Lever	M39	QBT1896	Lever Release Spring	M64	QMN2550	Roller	M92	XTN2+6B	Tapping Screw ±2×6
M14	QML3605	Auto-Stop Detection Lever	M40	QXL1381	Pressure Roller Assembly	M65	QDK1017	Steel Ball 2φ	M93	XTN26+6B	Tapping Screw ±2.6×6
M15	QML3592	Change Lever	M41	QBN1743	Pressure Roller Spring	M66	QBP1873	Head Base Plate Pressure Spring	M94	XTN26+10B	Tapping Screw ±2.6×10
M16	QMR1820	Record Rod	M42	QML3588	Fast Forward Lever	M67	QBT1597	Brake Arm Spring	M95	XTN26+12B	Tapping Screw ±2.6×12
M17	QMR1821	Auto-Stop Connection Rod	M43	QBN1748	Fast Forward Spring	M68	QBT1892	Head Release Spring	M96	XTN3+10B	Tapping Screw ±3×10
M18	QMR1822	Eject Rod	M44	QMA4063	Flywheel Retainer	M69	QMA3858	Head Adjustment Plate	M97	XTN3+24B	Tapping Screw ±3×24
M19	QMR1824	Control Rod	M45	QMA3920	Detection Lever Angle	M70	QZK0241	Takeup Gear Assembly	M98	XSN26+3	Screw ±2.6×3
M20	QMZ1239	Flywheel Thrust Retainer	M46	QMS2546	Detection Lever Shaft	M71	QXU0170	Motor Assembly	M99	XSN2+10	Screw ±2×10
M21	QBC1357	Lock Pin Pressure Spring	M47	QMF1682	Switch Retaining Plate	M72	QXX2286	Sub Chassis Assembly	M100	QBN1741	Change Lever Spring
M22	QBT1682	Auto-Stop Connection Rod Spring	M48	XSN2+6	Screw ±2×6	M73	QDG1199	Auto-Stop Gear	M101	XWG2	Washer 2φ
M23	QBT1894	Main Lever Spring	M49	QXF0164	Flywheel Assembly	M74	QDG1200	Cam Gear	M102	QML3644	Tape Detection Lever-A (for Metal Tape)
M24	QBN1739	Selection Lever Spring	M49-1	QBW2049	Poly Washer	M75	QDB0281	Capstan Belt	M103	QML3645	Tape Detection Lever-B (for CrO ₂ Tape)
M25	QBN1742	Pressure Roller Release Spring	M49-2	QBW2026	Washer	M76	QDB0274	Takeup Belt	M104	QBW2085	Poly Washer
M26	QBN1744	Sub Gear Spring	M50	QXD01143	Takeup Reel Table Assembly	M77	QDB0273	Fast Forward Belt	M105	XTN26+6BFZ	Tapping Screw ±2.6×6
			M51	QXL1382	Idler Lever Assembly	M78	QDB0273	Fast Forward Belt			
						M79	QXL1360	Record/Playback Selection Arm Assembly			

REPLACEMENT PARTS LIST

Ref. No.	Part No.	Part Name & Description	Ref. No.	Part No.	Part Name & Description	Ref. No.	Part No.	Part Name & Description
CABINET PARTS								
G 9	QKM0046	Obstruction Rod	G 28	QGBM0046	"Silver Type" Switch Angle (for S7)	G 10	QMAM0123	Obstruction Rod
G 1	[B] QKMM0044S	Main Case	G 11	XSN3+6S	Screw ±3×6	G 12	XWA3B	Washer 3φ
	[For United Kingdom.]		G 13	XTN3+10B	Screw ±3×10	G 29	QGRM0044K	"Black Type" Main Case
	[B] QKMM0044K	Main Case		XTN3+10BFZ	Screw ±3×10	G 30	QKJM0044S	"Silver Type" Main Case
	[For United Kingdom.]			XTN3+10BFZ	Screw ±3×10	G 31	QGKM0044S	"Black Type" Main Case
	[A] QKMM0047S	Main Case	G 14	QMA0129	Stopper	G 33	QML3581	Sub Control Lever
	[For Australia.]		G 15	QKJM0085	Mechanism Chassis	G 34	QBP1874	Cassette Pressure Spring
	[DN] QKMM0043S	Main Case	G 16 [D]	QGSM0175	Main Name Plate	G 35	QMR1821	Auto-Stop Connection Rod
	[For all European areas, Asia, Latin America, Middle East and Africa areas.]			[For all European areas except United Kingdom.]		G 36	QML3582	Pause Lock Lever
	[DN] QKMM0043K	Main Case		[N] QGSM0182	Main Name Plate	G 37	QDG1199	Auto-Stop Gear
	[For all European areas, Asia, Latin America, Middle East and Africa areas.]			[For Asia, Latin America, Middle East and Africa areas.]		G 38	QMN2550	Roller
	[BA] QGSM0176	Main Name Plate		[BA] QGSM0176	Main Name Plate			
	[For United Kingdom and Australia.]		G 2	QYBM0046	Bottom Cover Assembly	G 17	QMLM0041	Recording Lever
	"Silver Type"			QYBM0046K	Bottom Cover Assembly	G 18	QBSM0007	Recording Wire
	"Black Type"		G 19	XTN3+10B	Tapping Screw ±3×10	G 20	QNQ1070	Nut 12φ
G 2-1	QKA1083	Rubber Foot	G 21	XTN3+12B	Tapping Screw ±3×12	G 40	QXL149	"Silver Type" Main Name Plate
G 2-2	QHQ1313	Step Screw	G 22	QFM0019	Volume Angle (for VR3, 4)	G 41	QXL149	"Black Type" Main Name Plate
G 3	QYFM0057	Cassette Lid Assembly	G 23	XSN2+3	Screw ±2×3			
	"Silver Type"		G 24	SJS9607	Direct Connector			
	"Black Type"		G 25	QKJM0077	Direct Connector Holding Plate			
G 4	QYK0141	Input Level Control Knob Assembly	G 26	QKJM0079	P,C,B Holding Plate			
G 5	QGG0201	Slide Guide	G 27	[DBA] QGKM0182	Switch Shelter			
G 6	QGBM0023	Indicate Plate		"Silver Type"		G 42	QXL149	"Silver Type" Main Name Plate
	"Black Type"			QGBM0023K	Indicate Plate			
	"Black Type"			QGOM0087	Switch Button (for Dolby NR)			
G 7	QGOM0086	Power Button		[For all European areas and Australia.]				
				[DBA] QGKM0182K	Switch Shelter			
				"Black Type"				
				[For all European areas and Australia.]				

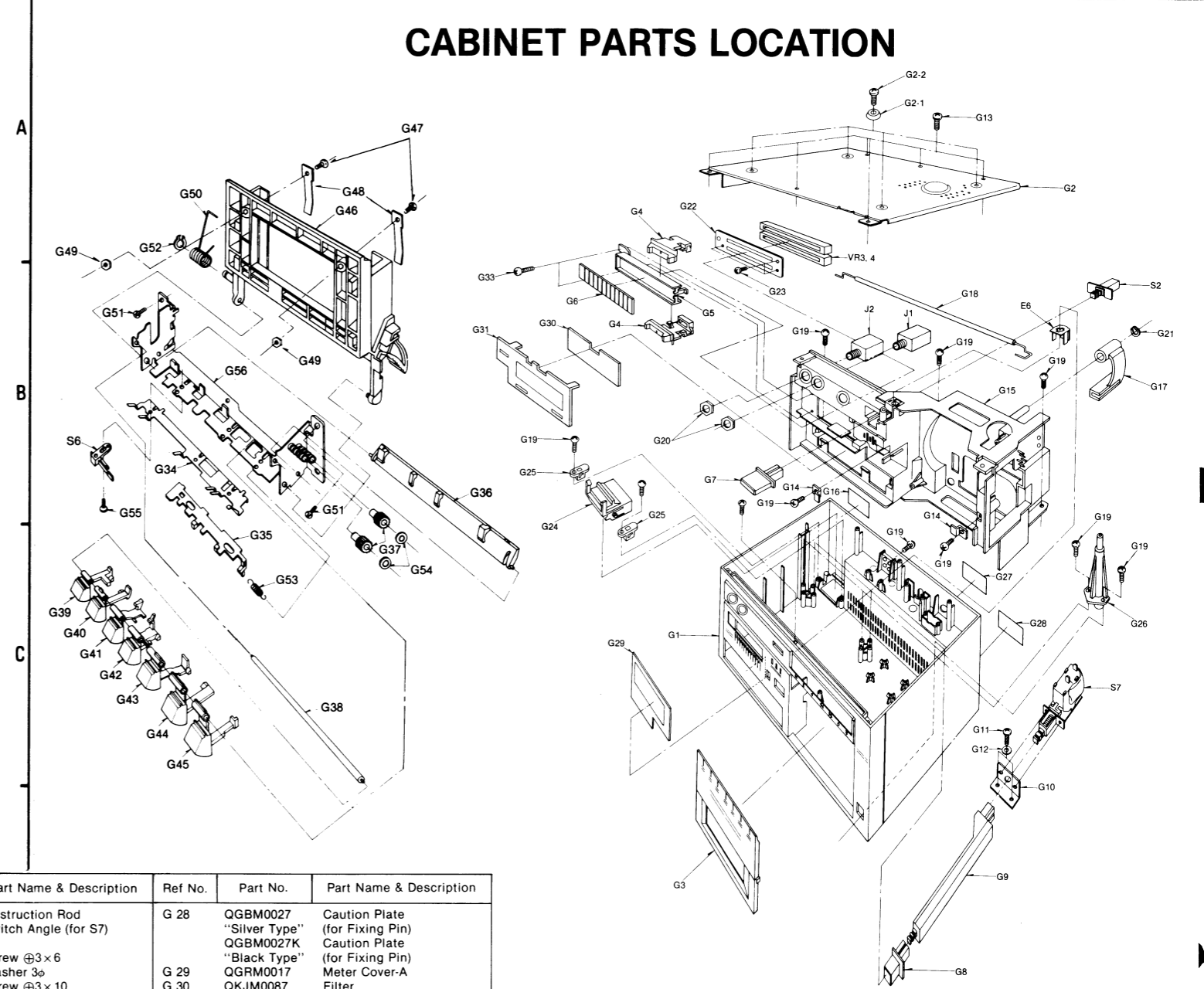
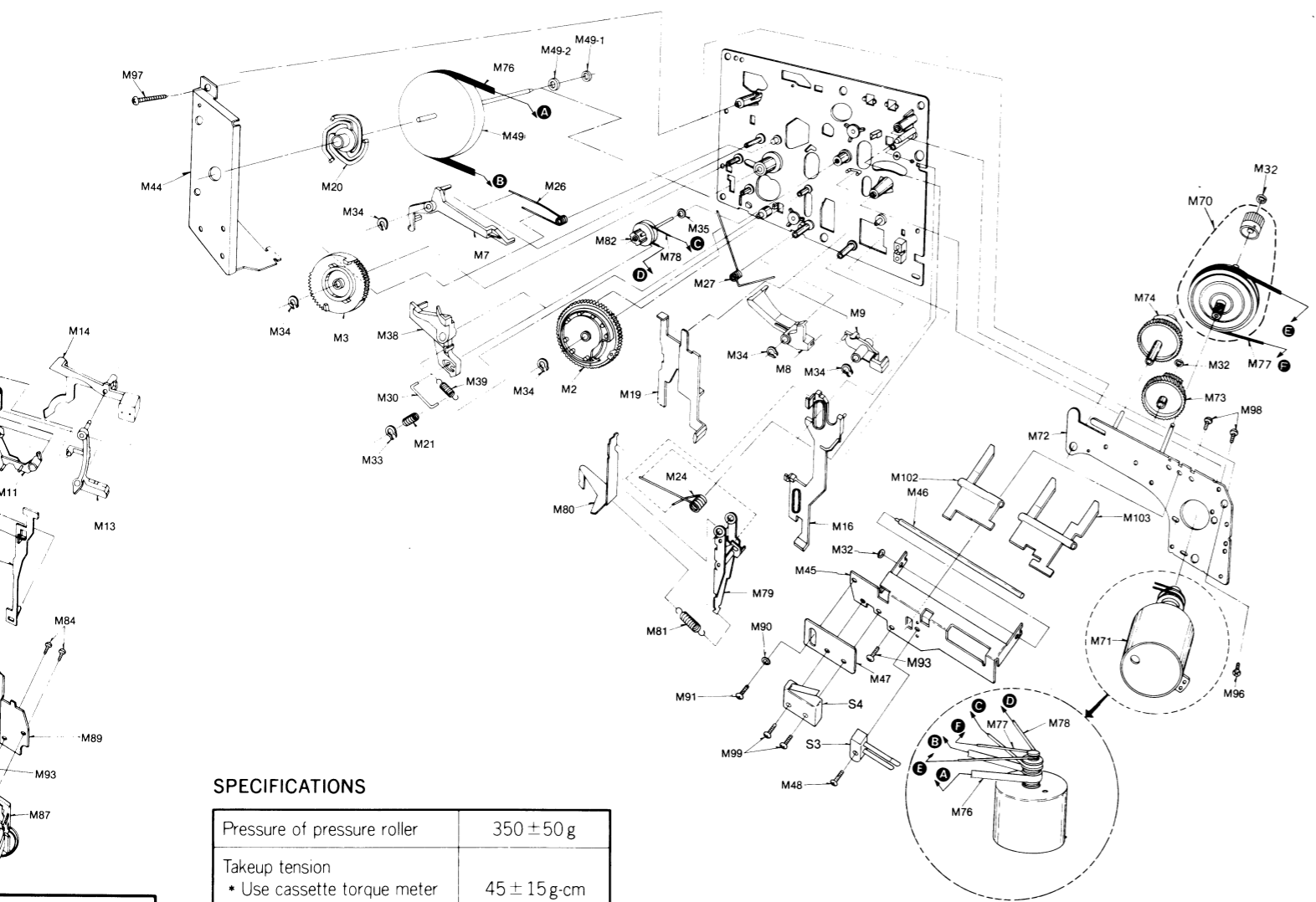

CABINET PARTS LOCATION

SPECIFICATIONS

Pressure of pressure roller	350 ± 50 g
Takeup tension • Use cassette torque meter ... QZZSRKCT	45 ± 15 g-cm
Wow and flutter: (JIS) • Use test tape ... QZZCWAT	Less than 0.06% (WRMS)

Assembly notes
Parts of RS-M51,
(s).

REPLACEMENT PARTS LIST

Ref No.	Part No.	Part Name & Description	Ref No.	Part No.	Part Name & Description	Ref No.	Part No.	Part Name & Description
CABINET PARTS								
G 1	[B] QKMM0044S	Main Case "Silver Type"	G 9	QKJM0046	Obstruction Rod	G 28	QGBM0027	Caution Plate (for Fixing Pin)
	[For United Kingdom.]		G 10	QMAM0123	Switch Angle (for S7)		QGBM0027K	Caution Plate (for Fixing Pin)
	[B] QKMM0044K	Main Case "Black Type"	G 11	XSN3+6S	Screw ⌀3×6	G 29	QGRM0017	Meter Cover-A
	[For United Kingdom.]		G 12	XWA3B	Washer 3φ	G 30	QKJM0087	Filter
	[A] QKMM0047S	Main Case "Silver Type"	G 13	XTN3+10B	Screw ⌀3×10			
	[For Australia.]			XTN3+10BFZ	Screw ⌀3×10	G 31	QGKM0180	Meter Cover-B
	[DN] QKMM0043S	Main Case "Silver Type"	G 14	QMAM0129	Stopper		QGKM0180K	Meter Cover-B
	[For all European areas, Asia, Latin America, Middle East and Africa areas.]		G 15	QKJM0085	Mechanism Chassis	G 33	XTN26+8B	Tapping Screw ⌀2.6×8
	[DN] QKMM0043K	Main Case "Black Type"	G 16	[D] QGSM0175	Main Name Plate	G 34	QBP1875	Obstruction Lever Spring
	[For all European areas, Asia, Latin America, Middle East and Africa areas.]			[For all European areas except United Kingdom.]		G 35	QMR1823	Obstruction Rod
	[BA] QGSM0176	Main Name Plate		[N] QGSM0182	Main Name Plate	G 36	QML3593	Lock Arm
	[For United Kingdom and Australia.]			[For Asia, Latin America, Middle East and Africa areas.]		G 37	QDG1102	Holder Gear
G 2	QYBM0046	Bottom Cover Assembly "Silver Type"	G 17	QMLM0041	Recording Lever	G 38	QMN2554	Operation Lever Shaft
	QYBM0046K	Bottom Cover Assembly "Black Type"	G 18	QBSM0007	Recording Wire	G 39	QXL1493	Eject Button Assembly
G 2-1	QKA1083	Rubber Foot	G 19	XTN3+10B	Tapping Screw ⌀3×10		QXL1581	Eject Button Assembly
G 2-2	QHQ1313	Step Screw	G 20	QNO1070	Nut 12φ	G 40	QXL1494	Record Button Assembly
G 3	QYFM0057	Cassette Lid Assembly "Silver Type"	G 21	XTN3+12B	Tapping Screw ⌀3×12		QXL1495	Rewind/Review Button Assembly
	QYFM0057K	Cassette Lid Assembly "Black Type"	G 22	QMFM0019	Volume Angle (for VR3, 4)		QXL1582	Record Button Assembly
G 4	QYK0141	Input Level Control Knob Assembly	G 23	XSN2+3	Screw ⌀2×3	G 41	QXL1495	Rewind/Review Button Assembly
G 5	QGG0201	Slide Guide	G 24	SJS9607	Direct Connector		QXL1583	Rewind/Review Button Assembly
G 6	QGBM0023	Indicate Plate "Silver Type"	G 25	QKJM0077	Direct Connector Holding Plate		QXL1584	Rewind/Review Button Assembly
	QGBM0023K	Indicate Plate "Black Type"	G 26	QKJM0079	P.C.B Holding Plate	G 42	QXL1496	Fast Forward/Cue Button Assembly
G 7	QGOM0087	Switch Button (for Dolby NR)	G 27	[DBA] QGKM0182	Switch Shelter "Silver Type"		QXL1584	Fast Forward/Cue Button Assembly
G 8	QGOM0086	Power Button		[For all European areas and Australia.]				

Part Name & Description	Ref. No.	Part No.	Part Name & Description
Idle Assembly	M80	QML3580	Record/Playback Selection Lever
Idle Spring	M81	QBT1895	Record/Playback Selection Lever Spring
Forward Idle Assembly			
Idle Assembly	M82	QXP0607	Fast Forward Connection Pulley Assembly
Forward Arm Assembly			
Base Plate	M83	QMK1838	Upper Base Plate
Spacer	M84	XSN3+5S	Screw ⌀3×5
Pressure Spring	M85	QDP1828	Fast Forward Pulley
Spring	M86	QXH0357H	Chassis Cover Assembly
Spring (for Erase Head)	M87	QXC0079	Tape Counter
Arm	M88	QDB0207	Counter Belt
Head Base Plate	M89	QMAM0150	Counter Angle
	M90	XWC26B	Washer 2.6φ
	M91	XSN26+6	Screw ⌀2.6×6
	M92	XTN2+6B	Tapping Screw ⌀2×6
	M93	XTN26+6B	Tapping Screw ⌀2.6×6
	M94	XTN26+10B	Tapping Screw ⌀2.6×10
	M95	XTN26+12B	Tapping Screw ⌀2.6×12
	M96	XTN3+10B	Tapping Screw ⌀3×10
	M97	XTN3+24B	Tapping Screw ⌀3×24
	M98	XSN26+3	Screw ⌀2.6×3
	M99	XSN2+10	Screw ⌀2×10
	M100	QBN1741	Change Lever Spring
	M101	XWG2	Washer 2φ
	M102	QML3644	Tape Detection Lever-A (for Metal Tape)
	M103	QML3645	Tape Detection Lever-B (for CrO ₂ Tape)
	M104	QBW2085	Poly Washer
	M105	XTN26+6BFZ	Tapping Screw ⌀2.6×6

Ref No.	Part No.	Part Name & Description	Ref No.	Part No.	Part Name & Description
G 43	QXL1497	Playback Button Assembly	A 2	SHE135	Fixing Pin
	QXL1585	Playback Button Assembly		SHE135-1	Fixing Pin
G 44	QXL1498	Stop Button Assembly	A 3	[D] QQT3307	Instruction Book
	QXL1586	Stop Button Assembly		[For all European areas except United Kingdom.]	
G 45	QXL1499	Pause Button Assembly		[B] QQT3308	Instruction Book
	QXL1587	Pause Button Assembly		[For United Kingdom.]	
	QXL1588	Pause Button Assembly		[N] QQT3309	Instruction Book
G 46	QKFM6007K	Cassette Holder		[For Asia, Latin America, Middle East and Africa areas.]	
G 47	XSN2+5	Screw ⌀2×5		[A] QQT3326	Instruction Book
G 48	QBP1899	Holder Spring		[For Australia.]	
G 49	XNG2E	Nut 2φ	PACKINGS		
G 50	QBN7008	Cassette Holder Spring	P 1	[N] QPNM0192	Inside Carton
G 51	XTN26+6B	Tapping Screw ⌀2.6×6		[For Asia, Latin America, Middle East and Africa areas.]	
G 52	XUB5FT	Stop Ring 5φ		[DBA] QPNM0189	Inside Carton
G 53	QBT1597	Obstruction Rod Spring		[For all European areas and Australia.]	
G 54	QBW2082	Washer	P 2	QPAM0052	Cushion
G 55	XTN2+6B	Tapping Screw ⌀2×6	P 3	[DBA] QPSM0009	Pad
G 56	QXA1044	Operation Button Angle Assembly		[For all European areas and Australia.]	
ACCESSORIES					
A 1	SJP2241-1	Connection Cord	P 4	XZB40X50A02	Poly Bag
			P 5	QPQ1052	Poly Sheet



Parts Change Notice

(D)...For all European areas except United Kingdom. (N)...For Asia, Latin America, Middle East and Africa areas. (A)...For Australia.
(B)...For United Kingdom.

Model No.

RS-5

Please revise the original parts list in the Service Manual to conform to the change(s) shown herein. If new part numbers are shown, be sure to use them when ordering parts.

Reason for Change		*The circled item indicates the reason. If no marking, see the Notes in the bottom column.			
1. Improve performance					
2. Change of material or dimension					
3. To meet approved specification					
4. Standardization					
5. Addition					
6. Deletion					
7. Correction					
8. Other					
Interchangeability Code		**The circled item indicates the interchangeability. If no marking, see the Notes in the bottom column.			
	Parts	Set Production			
A	Original	Early			Original or new parts may be used in early or late production set. Use original parts until exhausted, then stock new parts.
	New	Late			
B	Original	Early			Original parts may be used in early production sets only. New parts may be used in early or late production sets. Use original parts where possible, then stock new parts.
	New	Late			
C	Original	Early			New parts only may be used in early or late production sets. Stock new parts.
	New	Late			
D	Original	Early			Original parts may be used in early production sets only. New parts may be used in late production sets only. Stock both original and new parts.
	New	Late			
E	Other				
Part Number					
Model No.	Ref. No.	Original Part No.	New Part No.	Notes (* **)	Part Name & Descriptions
RS-5	R49, 50	ERO25CKG2003	ERD25TJ184	1-C	Resistors
"	R65, 66	ERD25FJ562	ERD25FJ332	"	"
"	R210	ERD25FJ471	ERD25FJ391	"	"
"	C3, 4	ECKD1H271KB	_____	"	Capacitors
"	C67, 68	ECQM1H223JZ	_____	1-A	"
"	C79, 80	ECQM1H183JZ	_____	"	"
"	C210	ECEA1VS331	ECEA1VS221	8-A	Capacitor
"	C211	ECEA1CS331	ECEA1CS221	"	"
"	C213 \triangle	ECEA1VS102	ECEA1VSS471	"	"
"	C214	ECEA1CS102	ECEA1CS471	"	"
NOTE: • Important safety notice Components identified by \triangle mark have special characteristics important for safety When replacing any of these components, use only manufacturer's specified parts					

File this Parts Change Notice with your copy of the Service Manual.

Original Service Manual is Model No. RS-5 Order No. ARD82050140C8-10.

Technics
National / Panasonic

Matsushita Electric Trading Co., Ltd.
 P.O. Box 288, Central Osaka Japan
 Printed in Japan.

Parts Change Notice

(D)...For all European areas except United Kingdom. (N)...For Asia, Latin America, Middle East and Africa areas. (A)...For Australia.

(B)...For United Kingdom.

Model No.

RS-5

Please revise the original parts list in the Service Manual to conform to the change(s) shown herein. If new part numbers are shown, be sure to use them when ordering parts.

Reason for Change		*The circled item indicates the reason. If no marking, see the Notes in the bottom column.			
1. Improve performance					
2. Change of material or dimension					
3. To meet approved specification					
4. Standardization					
5. Addition					
6. Deletion					
7. Correction					
8. Other					
Interchangeability Code		**The circled item indicates the interchangeability. If no marking, see the Notes in the bottom column.			
Parts	Set Production				
A	Original → Early New → Late				Original or new parts may be used in early or late production set. Use original parts until exhausted, then stock new parts.
B	Original → Early New → Late				Original parts may be used in early production sets only. New parts may be used in early or late production sets. Use original parts where possible, then stock new parts.
C	Original → Early New → Late				New parts only may be used in early or late production sets. Stock new parts.
D	Original → Early New → Late				Original parts may be used in early production sets only. New parts may be used in late production sets only. Stock both original and new parts.
E	Other				
Part Number					
Model No.	Ref. No.	Original Part No.	New Part No.	Notes (* - **)	Part Name & Descriptions
RS-5	Q1, 2	2SC1328-S	2SC1844F	8-A	Transistors
"	Q3, 4	2SC1328-S	2SC945P	"	"
"	Q19, 30	2SA999	2SA1115E	"	"
"	Q21, 22	2SD965	2SD471	"	"
"	Q25	2SD592	2SD471	"	Transistor

Original Service Manual is Model No. RS-5 Order No. ARD82050140C8-10.

Technics
National / Panasonic

Matsushita Electric Trading Co., Ltd.
 P.O. Box 288, Central Osaka Japan
 Printed in Japan.