

A Report on the
Salvaging, Screening and Inventorying of Carved Wooden Elements of
HANUMAN DHOKA PALACE COMPLEX
(Organized by the Department of Archaeology with support from the
UNESCO Kathmandu and in collaboration with ICOMOS Nepal)



Pun Dega, Maju Dega and Narayan Temple (Before Earthquake)

November 2015 - October 2016

Submitted by:

Prof. Mukunda Raj Aryal

Sukra Sagar Shrestha

TABLE OF CONTENT

Chapters	Page
1. Introduction	01
2. Rulers of Hanuman Dhoka in a nutshell	03
3. 2015 Earthquake and its effects	05
4. Woodworks Salvaged In Hanumandhoka Palace Complex	09
5. Compendium	11
6. Annex	
a. Annex 01 Vernacular words explained	-
b. Annex 02 History of Wooden Heritage in Nepal	-
c. Annex 03 Summary of artifacts recovered	-
d. Annex 04 Location of artifacts stored In open space	-
7. Appendix 01: Culture Sheets Of Collapsed Monuments	
8. Appendix 02: Inventory Sheets of Collapsed Monuments	

CHAPTER 1

INTRODUCTION

Kathmandu Durbar Square, also known as Hanumandhoka Royal palace, is the most extensive of all the three royal palaces in the Kathmandu valley. Not only in its actual size, but also in the scale of its entirety-open spaces, water bodies, temples, palace buildings and structures, Kathmandu Durbar square is important having sixty important individual structures dating from 16/17th. Century. The presence of mega size stone craft, tallest palatial structure of Basantpur Durbar and extensive temple of Talezu along with the master pieces of antic stone icons of as old as 6/7th Centuries prove the site to be very old.

The palace compound once was much more extensive than today. Francis Hamilton remarked it in an astonishing magnitude in 1819A.D. Henry Oldfield reported having forty to fifty different courts of various sizes each having separate names.

Percy Brown writes on Hanumandhoka palace complex as there is only word to describe the city of Kathmandu and its palace that is "Picturesque". He goes on to write that during his visit in 1910s it was in design confused labyrinth of quadrangles, passages and chambers- a mighty maze without a plan and consists of a collection of forty or fifty courtyards of different sizes, each having a separate names.

It was somehow the customary design to make the royal courts of Newar palatial complexes into two broad divisions- one for purely residential purpose and in front the congregation of all the temples of king's own pantheon. The tutelary deities are placed inside the palatial complex and other general deities in front at the surroundings of the complex.

The architectural ensembles of Hanumandhoka square begin with the reign of King Mahendra Malla in the second half of fifteenth century when he constructed the beautiful temple of *Talezu* here. Later it was enlarged and embellished more with many objects by King Pratap Malla who constructed Mohanchowk in 1648 and carved in a beautiful *hiti* next year added Mulchowk and Nasalchowks in course of time. Jayaprakas Malla the last king of Kantipur added the beautiful courtyard of Kumari bahal in 1756.

However among the principal monuments in the square, the *Talezu* temple is the oldest and was erected in 1576. Till date this temple is one of the massive and more embellished than any other temples of Nepal. This is the only temple that is supported by two layers of struts and three layers of spine walls. There are additional struts inside the main walls above the ground floor. The superstructure and architecture of it is still not fully studied which is felt urgent necessity.

In 1769 following the occupation of the palace by King Prithvi Narayan Shah, the architecture although made higher than before the taste retained same. The Nautale is an example. The conspicuous changes of architecture are noticed from the time of Bhimsen Thapa who without any thought changed the southern façade of Mohanchowk into presents shape. The seemingly changes in architecture started after the return of Jang Bahadur from

Europe in 1851. He brought new trend of architecture in Kathmandu. He added the foreign architectural elements to the south wing of Hanumandhoka palace complex in which Chandra Shumser added purely Roman Architecture of *Gaddi Baidhak* in 1908. But most of the magnificent temples that stand in the square date from 17th Century. They are in their traditional styles.

The interest on white buildings attracted those Rana regimes so much that they even covered the sweet and matching brick walls and wooden windows of *Kumaribahal* with lime plaster from outside. The plaster was later removed in 1980s to the present state of the façade by Department of Archaeology that remained intact till date.

Kathmandu Durbar Square is the most extensive of all the three royal palaces in the Kathmandu valley. The complex is now the storehouse of different ancient monuments with twenty five temples, two monastic complexes, two big rest houses, ten courtyards (*chowks*) four stone pillars with statues and one big bell.

CHAPTER 2

RULERS OF HANUMAN DHOKA IN A NUTSHELL

The political history of Hanumandhoka palace complex before Ratna Malla (1482-1500) is shrouded in the clouds, therefore not clear. What was there before him is shrouded in the mist. There could be a palace or not. However the place seems with some hints to be the palace area. But once Ratna Malla captured the power from *Thakujujus*(Thakuri rulers) in 1482 then the kingship went down with full recorded chain until the last king Gyanendra. Total of 24 kings ruled from this palace until 2008. Then the kingship from Nepal was uprooted forever. Even after the royal seat was shifted to Narayanhiti palace in 1896 A.D. Hanumandhoka remained seat for the kings to celebrate all important events like coronation, marriage and so on because Narayanhiti palace complex could not give them cultural taste.

A short chronology of kings who ruled from the palace is therefore given here.

Malla rulers:

- Ratna Malla
- Surya Malla
- Amar Malla
- Mahendra Malla
- Sadasiva Malla
- Laxminarasinha Malla
- Laxminarasinha Malla
- Pratap Malla
- Nripendra Malla
- Parthivendra Malla
- Bhupalendra Malla
- Bhaskar Malla
- Jagajjaya Malla
- Jaya Prakash Malla(last Malla king of Kantipur(Kathmandu

Gorkha rulers:

- Prithvi Narayan Shah
- Pratapsinha Shah
- Rana Bahadur Shah
- Girvana Yuddha Bikram Shah,
- Surendra Bikram Shah
- Prithvi Vir BikramShah(moved his residence to present **Narayanhiti palace**)
- Tribhuvan Vir Bikram Shah
- Mahendra Vir Bikram Shah
- Birendra Vir Bikram Shah
- Dipendra Vir Bikram Shah
- Gyanendra Vir Bikram Shah (thrown off in 2008 from people's revolution)

CHAPTER 3

2015 EARTHQUAKE AND ITS EFFECTS



The moment of 11.56 AM on 25 April 2015 was the great devastation of central Nepal including Kathmandu valley. The earth around the area shook almost for a minute at the Richter scale of 7.8 that caused to collapse ten structures completely and some more partially in and around Hanumandhoka World Heritage Complex. The famous structure of Kasthamandapa(*Marusatah* in Newari) from which it is believed that the name of the capital city derived collapsed completely killing more than a dozen people who were donating the blood to Red Cross during the unfortunate moment. Three sister temples that were standing to the east of this building forming a beautiful landscape of the area were also crushed to the dusty heaps. In a moment within a minute the landscape turned to be a ghost zone.

In the chaos of emergency rescue operation after the earthquake, the timber members/and other elements that fell down from damaged or collapsed monuments of Hanuaman Dhoka Durbr Square were rapidly piled in different locations, and in repeated clearing activities, that was done in short period of time with hectic situation and in unplanned ways, timber members and other elements from damaged or collapsed monuments got mixed up making them quite difficult to separate according to the monuments to which they belong to. Besides that, due to the approaching rainy season it was felt necessary to provide them adequate rain protection. But the lack of resources and coordination, all response activities were proved to be very slow and insufficient.



It was found that the dispersed timber elements were piled in more than 23 different locations. The need to salvage, sort and inventory them was widely voiced. The discussion on planning continued for months. And only in November 2015 with the agreement between different stakeholders including the Department of Archaeology, Hanumandhoka Museum Development Committee, UNESCO Office in Kathmandu and ICOMOS Nepal, it was decided to carry out the work of salvaging, sorting and inventorying work of dispersed timber members of Hanumandhoka Palace complex.



In the mean time, UNESCO office in Kathmandu also supported for building a temporary storage house of size 30x60 feet to the east of Taleju temple inside Trishul Chowk. The construction of the shed was carried out by DR Construction followed by the more smaller shades one each to the east of Nagpokhari and below Bhaktapur tower that could become ready only in the month of July/ August at the

last end of our work period. Lack of space proved to be the great hurdle in work progress during the entire period.



Monuments affected by 2015 Earthquake: All the monuments were very badly shaken by the earthquake. Ten structures were totally collapsed and some though remain standing are badly cracked of using no more possibility until the further extensive repairs could be carried out and some are to be simply stitched and repaired. Out of ten monuments that collapsed for which our team's service was sought for the separating, screening and inventorying the objects are:





The structures collapsed during the earthquake with details:

1. Kasthamandapa
2. Nau Dega (Bimallesvara)
3. Pun Dega (Trailokya Mohan Temple)
4. Maju Dega
5. Santanesvara Temple
6. Garud Narayan Temple
7. Chyasin Dega
8. Shiva Temple
9. Basantapur Durbar (Nau Tale Durbar)
10. Bhaktapur Tower

CHAPTER 4

WOODWORKS SALVAGED IN HANUMANDHOKA PALACE COMPLEX

The whole Durbar Square of Hanuman Dhoka is full of ancient inscriptions, sculptures and monuments of various size and shapes. The existing monuments, we see today, are from medieval period and the whole skyline is full of temples that remind us the remarks made by William Kirkpatrick that *there are as many temples as many houses and as many gods as many people*. He did not exaggerate the landscape he saw that time. The monuments around here were raised in Early Lichhavi, Classical Lichhavi, Early Medieval, Late Medieval and Shah Rulers in their succession expanding almost for two thousand years. The Lichhavi evidences are left in the form of icons and inscriptions only.

Kathmandu Valley is within the most dangerous earthquake zone as such so many palaces and monuments were demolished in earthquakes. The Enthusiastic rulers and people raised them again. The great earthquakes of 1934 demolished so many temples and monuments of the valley and were re-raised.

The Last earthquake of 2015 demolished nearly a dozen monuments of historical, archaeological, artistic and cultural importance around here.

Many international donors and agencies came forward in providing technical and financial support to re-erect them through the Department of Archaeology and UNESCO. The nature of work itself is time taking.

The work started first from the clearance of debris then screening the objects in them, documenting and inventorying at last.

The first phase of reconstruction work has already been started. We have been able to clear the debris of the monuments and separate the Iconography of the timber elements, architecture and decorative pieces and preserve them in the shades, three in number constructed for us by UNESCO. They are arranged with a scientific report to guide the Architects in future to reconstruct the structures.

Our report carry, as our knowledge permitted, the information gathered from the following structures that were collapsed.

1. Kasthamandap (Maru Sata:)
2. Naudega(Bimalasvara Temple)
3. Pun Dega (Trailokya Mohan Temple)
4. Maju Dega
5. Santanesvara
6. Garud Narayan temple
7. Chyasin Dega (Krishna Temple / Vamsha Gopal Temple)
8. Shiva Temple
9. Basantapur Durbar (*Nautale* Durbar)
10. Bhaktapur Tower

CHAPTER 5

COMPENDIUM

It is not necessarily important again to mention the details of the earthquake. However for the sake of history a short note on the event will not be exaggeration. At 11.56 A.M on Saturday in the morning of 25th. April 2015 the surface of earth in central Nepal trembled suddenly for almost a minute that caused 9000 deaths, 27000 injured, thousands of houses and hundreds of monuments collapsed. Additional major after-shock came within three weeks again.

In total ten out of the numerous monuments in Hanuman Dhoka Palace leveled to the ground turning into 23 debris of major heaps. Many more structures also cracked that need to be renovated in the future

The concerned authorities like the DoA and its various offices, Nepalese Army Personnels, police and public volunteered to clean the debris and preserve the buried art and architectural pieces, icons, pinnacles and other valuables.

The carved elements were dumped in various places like Nasal Chowk, Dakh Chowk, Lohan Chowk, Trishul Chowk, to the east and west of Shiva Parvati Temple, Jagannath Temple, Sinha Dhoka of Taleju, around Kasthamandap and other places. To the best of the available manpower and places, the gold and gilt icons and other valuables were kept in the custody of Hanuman Dhoka Durbar Museum Development Committee.

The DoA, in collaboration with ICOMOS Nepal and UNESCO Kathmandu, formed a committee of Professor Mukunda Aryal, Archaeologist Sukra Sagar Shrestha, Photographer Sunil Dangol, Mr. Dipendra Shrestha, Ms. Anju Shakya, to separate, screen and prepare scientific inventory of the carved wooden elements of various temples and monuments scattered around. The team started its work from the end of November 2015 with the help of experienced master carpenters Sushil Rajbhandari, Rakesh Birbal and others.

The job was a big challenge to the team. First the team separated the carved wooden elements and uncarved ones. Among the carved ones the pieces of various architectural elements like different kinds of windows, doors, door jambs, entablature, cornice, *dhalinkhwaas*, *dhalinkawas*, struts and corner struts has have to be spared, separate and refix them as far as possible. The next phase was to be photographed to prepare a scientific inventory and cataloged. Due to the shortage of open space the same thing were to be shifted repeatedly. The salvaged pieces were stored in a shelter to the east of Taleju Temple, to the east and west of Nag Pokhari, on the plinth of Nasal chowk and Lohan Chowk and in the northern side of Lohan Chowk. The uncarved pieces were measured and stored in the different chowks of Hanuman Dhoka, covered with tents to protect them against the weather. The salvaged carved wooden elements were separated, screened, assembled into doors and window elements, photographed individually and prepared a detailed scientific inventory.

A few sheet of cultural information have been prepared of 10 independent monuments with its introduction like Kasthamandap, Maju Dega, Trailokya Mohan (Pun Dega), Vishveshvar, Shiva Temple, Vamshagopal (locally known as *Chyasin Dega*), Santaneshvara, Garud

Narayan and the famous Basantapur Tower (*Nautale Darbar*). The individual artefacts of individual monuments are filled in with the photographs and measurements as an inventory form. The hardcopy and soft copies are also attached herewith for further work in the future.

This is the first time we all experienced such mammoth work. We have been taught by the experience that no work of such nature could be achieved in first attempt. We feel that the work has just started. There is long way still to go to achieve the necessary result. However we are proud in accomplishing the progress in our work that was entrusted to us. We think, we accomplished the work satisfactorily, though belated.

We hope it will not be out of context to mention some notes what we felt during our work.

- The nature of work could not be calculated precisely in advance since this sort of hectic moment never occurred before. This made all speculation of ours failed one after other.
- The heterogeneous group of work force with civil servants, hired academicians and army personals work force made coordination difficult. However, the cooperation that was received from all parties was helpful in the continuation of the work.
- The space available for the work was not sufficient. Due to lack of space inside Hanuman Dhoka Palace premise, not other shelters could be built for storage purpose. By the end of the program only three shelters could be set up with support from UNESCO Kathmandu. Therefore, many elements were grouped and covered with tarpaulin sheets in open space.

We feel, the work of selection, separation and inventorying is has been completed. The second job is now to clean them chemically or manually and stitch the artistic members by the skilled hands of the carpenters. We have to establish the workshop where all the carved members could be stitched, recarved unusable portions and if required, new ones need to be carved to replace lost windows, pillars, struts and doors.

In the end we want to share that something like this never occurred before. So our work might be or can be a guideline to the future generation in times of disaster like this.

We would like to thank all who provided us the opportunity to work on this project. We especially want to mention and are grateful to all the concerned officials of UNESCO Kathmandu and to ICOMOS Nepal, mostly to Mr. Kai Weise, Mr. Manindra Shrestha and to Dr. Suresh S. Shrestha of DoA.

ANNEX

ANNEX 1: VERNACULAR WORDS EXPLAINED

ANNEX 2: HISTORY OF WOODEN HERITAGE IN NEPAL

ANNEX 3: SUMMARY OF ARTIFACT RECOVERED

ANNEX: LOCATION OF ARTIFACTS STORED IN OPEN SPACE

ANNEX 1

VERNACULAR WORDS EXPLAINED

The window types in Newar architecture could broadly be divided into following types.

Sanjhyaa

Tikijhyaa

#Dyajhyaa

#other miscellaneous jhyaas

Jhyaa (Newari): Window

Tikijhyaa (Newari): In Nepali it is called *aankhinjhyaal*. In English it is trellis window.

Sanjhyaa (Newari): A multiple bay window from three to fifty five windows in a row but always in an odd number. Under this type many varieties are recorded with the sub names.

Bimaajhyaa (Newari)

Bidhijhyaa (Newari)

Thaakujhyaa (Newari)

(These three have to be defined after looking in detail through the evidences)

Kunjhyaa (Newari): window fixed in the corners of a building either they are in concave or convex position are simply called kunjhyaa meaning a corner window. After earthquake this type is almost finished except one in Patan Durbar and one in Kathmandu Durbar.

Yakujhya (Newari) This type of window is fixed on the walls below the extended brackets (?) called Yakubaha in Newari. The right angle formed by the door frame and extended bracket is called Yako or Yaku in Newari. The window fixed below this became Yaku or Yako Jhyaa. They are often closed with a figure of a divinity.

Dyajhyaa (Newari) All type of the windows related to the religious architecture fall on this category. They are Paasukhaajhyaa(having five bays), Trikhajhyaa(having only three bays) also is called swakhaajhyaa, and Yaakujhyaa then Yaakah jhyaa come under this category.

Dyapwaas (Newari) All the holes made for the gods, demons and goblins for their communications that are made in temples, houses, *sattals*, *phalechas* and even in defense walls could be called *dyapwaa*.

Miscellaneous *jhyaa*: All other types are termed only as *jhyaa*. Usually people name them as they like.

Tuna (*Newari*): Tundal in Nepali and strut in English.

Kunsala (*Newari*): Corner struts in English.

Tolan or Toran (both in *Newari*) **Torana** in *Nepali*: Tympanum in English

Thaan (*Newari*), **Thaam** in *Nepali* and in English it is pillar.

Meth(*Newari*): Bracket in English

Chakulaan (*Newari*): A square plate carved or uncarved placed in between the pillar and bracket to enhance the beauty

Kaarnes: Cornice in English

Dhalinkava (*Newari*): End faces of the beams carved with different motifs often with the heads of animal beings.

Dhalinkhwaa (*Newari*): Square space left between two beams and decorated with multiple patterns. A renowned cultural historian Mary Slusser defined it as **concealed cornice**.

Naudega (*Newari*): Name of a temple, the plinth of which used to be always occupied by the barbers (*nau*) to sell their service.

Maajudega (*Newari*): Name of a temple erected by queen mother Riddhi Laxmi. Maaju means honorable mother.

Chyaasindega (*Newari*): Chyaasin means eight angles thus the name of a temple having octagonal plan

Satah (*Marusatah*) (*Newari*), **Sattal in Nepali**: Rest house in English.

Sikhara (*Sikhara style*) : A mountain peak is called *sikhara* thus the peak shaped temple

Santaanesvara: God of family or the God who gives boon to proliferate a family.

Gopinis: Name of the multiple wives of Krishna.

ANNEX 2

HISTORY OF WOODEN HERITAGE IN NEPAL

Certainly no people have gone so far as the Nepalese in the art of wood carving.

Gustav Lo Bon.

Gustav Le bon was the first man who tried to understand about the intricacy of Nepalese wood works and did first in-depth study on the subject and wrote about the contemporary society of carpenters. According to him there were only fifteen artists of wood carvers in Kathmandu valley during the second half of 19th. Century Nepal.

S.B. Deo did another study in detail for the first time on typology of wood patterns, its varieties and profusion of depiction during 1960s of last century and published a monogram on the subject.

Deo was followed by Niels Gutschow and Ishvarananda Shresthacharya who made an additional study and made a book on Dictionary of Newari Architecture named **Newar Towns and Buildings**.

Surendra Joshi and Bijaya Basukala became first Nepalese in this field to record by drawing every detail of wood works from Nepalese architecture. At last Ganendra Joshi and Rajan Shrestha came forward to illustrate wooden heritage of Nepal who are ultimately replaced now by the computer technology of Illustration. Who knows, one day, even the carving would be replaced by computer driven laser machine to carve the wooden members in Nepalese temples. Ultimately we have to wash out the hands from wood carving heritage of Nepal !

In course of our work in Hanumandhoka, we came to realize that this is the great moment to dig more into the subject. Therefore with the help of the old people and looking at the shape, use and size of the parts in the buildings the nomenclatures are tasted and tried to define about them in this report. Newars have created such a profuse number of patterns, designs and figures that decorated the members of their buildings without proper nomenclatures of them all. It has been found that the nomenclatures of the parts of the building are very poorly defined. So to say almost there is no definition at all. If there are some they are also over powered by the immigrant languages on the name of nationality.

The important facets of wood carving that we came across during our work are illustrated in following pages.

First comes the windows. Typologically the windows can be divided into following categories:

WINDOWS

We are used to define in our built environment in a rational term as:

A window is a translucent opening in a wall that allows the passage of light and if not closed or sealed air and sound. If a building is defined as a human body then the windows can be regarded as eyes. Therefore the eyes are existential necessity. Other functional requirements take a secondary importance.

In Newari, a window is termed simply as Jhyaa. Newars have maximum varieties of windows made of wood. There is more than three dozen different names recorded referring to the window. But they have not been categorized according to their typology and use. No one, it seems, has gone through the typological study and categorized them. They simply recorded the name and termed that as types.

Categorically Newari windows can be divided into:

San Jhyaa= A multiple bay windows from three to fifty five windows in a row but always in an odd number.

Under this type many varieties are recorded with the names. They are:

- Bimaajhyaa
- Bidhijhyaa
- Thaakujhuuaa

Tikijhyaa= A grilled window that is fixed and cannot be open and closed. One can see through from inside but no one can perceive from outside what is going on inside. Most of the decorative windows falls on this category like peacock window (Mhayekhahjhyaa in Newari and Mayurjhyal in Nepali), sungod window (Surdyajhyaa in Newari and Suryajhyal in Nepali), palanquine window and so on.

The grill made in different pattern in this type of windows is the master craftsmanship of Newars. A thorough study on the typology of the pattern alone is an essential at the moment because the opportunity is at hand after the great earthquake of 2015.

Kunjhyaa= This type of window is fixed in the corners of the buildings either they are in concave or convex form. The windows in this position are simply called *kunjhyaa* meaning a corner window. After the earthquake this type is almost finished except one left in Patan Durbar one in private house of Bhaktapur.

Gaajhyaa= This type of window is made adding extra decorative pillars on both sides making the centre looking deeper. It also comes under the decorative type of window because most of this example is found used in the upper storey of the temples often at the centre of the wall. Sometimes, if the donor of the temple is rich enough then the central one could be followed by two Gaajhyaas on both sides but in smaller size to beautify the wall. The simple meaning of the word is deeper (like ditch) window.

Gahjhyaa= Not to be confused with *Gaajhyaa* because it is pronounced almost same way. This one almost looks like *Gaajhyaa* type but remains without the *tolanthaan* often closed with the faces of divine figures and can never be opened. The word is translated as the windows found in many number or group of windows.

Yaakahjhyaa= A single standing window of all type that can be open and closed comes under this category. Most often the single windows having full operational leaves and standing on both sides of the Sanjhyaa fall under this category.

Yakujhya= This type of window is fixed on the walls below the extended brackets(?) called Yakubaha in Newari. The right angle formed by the door frame and extended bracket is called Yajo or Yaku in Newari. The window fixed below this became Yaku or Yako Jhyaa.

Dyajhyaa= All type of the windows related to the religious architecture fall on this category. They are Paasukhaajhyaa(having five bays), Trikhajhyaa(having only three bays) also is called swakhaajhyaa, and Yaakujhyaa then Yaakah jhyaa come under this category.

Dyapwaas= All the holes made for the gods, demons and goblins for their communications that are made in temples, houses, *sattals*, *phalechas* and even in defense walls could be called *dyapwaa*.

Miscellaneous *jhyaa*: All other types are termed only as *jhyaa*. Usually people name them as they like.

(Usually the nomenclatures on typology are found always confused. One should be cautious in same type of pronunciation. For clarification:

Yaku jhyaa: This type of windows are fixed only in the religious monuments and they are small in size and fixed besides the doors in ground floor and by the side of big windows above the ground floors of many temples or monasteries.(**photo**). Some people also call this as yakvajhya also. One should not be confused with Yaakah jhyaa of another type.

Gahjhyaa and Gaajhyaa: These two types look almost similar and differ only in size are thus most confusing. If this is used at the center becomes Gaajhyaa and if at the sides becomes Gahjhyaa. Gahjhyaa means the windows used in groups or multiple numbers and Gaajhyaa means the windows deeper at the center because of multiple small pillars used on them.

Same Gahjhyaa becomes Gaajhya for Bhaktapur people because their way of pronunciation is different than the rest of the Newars in Kathmandu valley. For them Gah means Gaah of other Newars.

STRUTS

This part of structure is termed as *Tunal* in Nepali and *Twaanaasin* or *Tunaasin* in *Newari*. But Bhaktapur people term this as *Vilanpau* in case if it is carved. If plain then they also call as *Tunaasin*.

The meaning of the word in Newari means a tibia of human leg that is lower extremity. Like a tibia it is thin and most strong part of the human body. The struts in Nepalese temples are regarded as strong. The tibia carries whole weight of a human body. In the same way the struts of a temple also carry the whole weight of a roof.

The Newar architects thought in depth about the nomenclature of the struts and its function which is unique and constructive. The architects in Nepal have a brilliant thought in temple architecture. By using struts, they created wide open space inside the temples in different

storey. But unfortunately they did not use them purposefully other than in some rectangular temples of Bhairavas and Bhimsena.

There are multi roofed temples in Japan also looking similar to Nepalese counterparts from outside but the Japanese ones are erected not in strut principals but in spine pillar support system. Therefore Japanese examples do not have open space like that of Nepalese temples.

The main function of the struts is to transfer the whole weight of the roofs to the spine wall then transmit that to the gravity. **The principle is the real invention of Kathmandu architects.**

A strut has many functions in Nepalese architecture. Besides the duty mentioned above it beautifies the temple. Struts play a decorative piece of art after the tympanum. This is the part that keeps ever exposed. Therefore the place is a best part for an artist to exhibit his or her art round the clock. Whoever comes to the temple, his or her eyes first of all falls on them. The result is that it always carries the interesting and important subject that an artist creates,. The position of the strut itself is placed in such a way that a devotee can always look at them on east. Therefore it is the place for multifarious Gods, and Goddesses followed by different subjects on them.

Usually the struts have three parts. One fourth on top covers with the vegetal environment carving that represents the nature. Half the portion at the middle is dedicated to the main divine figure that represents the heaven and last one fourth portion is assigned for different subjects to carve from carving *vahanas*(riding vehicles) of main figures to inscriptions, story and different social scenes to even the erotic carving also to infuse the sexual knowledge to the youngsters.

CORNER STRUTS (KUNSALA)

Kunsala means the horse in the corner. But the struts never contain a figure of a horse. Why it is called so is a matter of further research. In Nepali there no separate name for this. Simply the people call Bhyaala. Due to its position in the four corners of the temple therefore a name. The duty of four corner struts are to keep the roofs stretched and balanced and carry their weight as well. Therefore the size of the corner struts is always long and thick.

Usually four struts as a practice should have figures of four esoteric animals. They are sinha, saardula, ajaraakula and mahaanaga having heads of a lion, griffin, a goat and of a serpent. One pure example could be cited from Trishul shrine inside the Hanumandhoka Royal Palace Complex

TYAMPANUM (TORANA)

A tympanum is called in *Newari Tolan* and *Torana* in Nepali. In west it is often the part semi-circular or triangular wall surface above an entrance or porch. It covers only a circular segment coming to the point at the top and usually contains a religious imagery either an icon or a painting.

In Nepal it is an independent architectural piece containing elaborative decoration and is hung above all entrance. In Newar architecture a tympanum appears around sixth century

Buddhist votive stupas in miniature size. They are arc shaped and supported by pairs of pilasters. But the earliest wooden tympanum dates to 10 to 12 century. After 14th. century, countless arc shaped tympana on top of the gateways, doors, windows and interior shrines came up.

The central figure of a tympanum is always a mirror copy of the deity who is enshrined inside the temple. A devotee will therefore earn an equal merit just paying the tribute to the tympanum.

The symmetry of all tympana is maintained with the figures of *Chhepu* on top and *Makaras* in two ends of the lower corner no matter how many extra figures or ornamental patterns are grouped in the middle. All the figures related to the main icons are accommodated with the frame.

However no *torana* has been salvaged at all from any heaps of Hanumandhoka Palace Complex showing tympana were no more on in situ before the destruction caused by the earthquake.

COLUMNS (PILLARS)

A pillar is called *Thaan* in Newari and *Thaam* in Nepali. This member of the structure works in two ways in carrying the weight of the temple and working as a place for decoration. The columns are shaped in square, often but found in octagonal and round in cross sections also. Perhaps Nepalese pillars or columns are the shortest and tiniest in terms of universal size for example Greek, Roman, *Mouryan* and Gupta pillar. If we take an example of a column from a *Gaajhyaa* this would be the micro size pillar of them all.

BRACKETS

Bracket is called *Meth* in Newari and Nepali languages. This is the part of a Nepalese architecture where the diverse designs and subjects are displayed from deities, dragons, social scenes like wars, amorous couples and seers in meditation to even erotic depictions. This member remains between the beam and pillar giving extended support to the beam horizontally.

Nepalese brackets are short and matching to the space in comparison to the brackets used in China and other Central Asian countries. The predecessor design of the Nepalese brackets is the ones used in the caves of Ajanta and Eloura of India. But the Indian ones are thicker ones being on stone.

This is the counterpart of capital portion of Hellenistic architecture. Verities of brackets are salvaged from the dumps of Hanumandhoka. Two main types are full *meth* and corner *meths* meaning full brackets and half brackets that are used in center pillars and corner pillars respectively.

CHAKULAAN

Thinner than the main bracket in square shape are often placed between the pillars and the main bracket. The aim of this thin bracket is to enhance the beauty of the particular part in the architecture. Usually this type would be square in shape but sometimes it is also rectangular in shape if there are two pillars put together. This is called **Chakulaan** in Newari.

Most of the square brackets are found in broken state from Hanumandhoka after the collapse on earthquake of 2015.

KAARNES (CORNICE)

this is the decorative band of cornice pronounced almost akin to English in Nepalese tone as *kaarnes*. This is the most conspicuous part often in the front walls of any structure running horizontally at a point that divides the storey. This portion though laboriously made and decorated has no Nepali name and thus simply called as *Kaarnes* similar to English Cornice.

The band is comprised from three to seven layers of carved members of the wood depending on the economic condition of the builder. Among them the layer of the beam ends are especially noteworthy because the beam ends are carved with the faces of different animals, dragons, gnomes and even human beings looking at the onlookers. Therefore this part is called

DHALINKHWAA

the face end of a beam. The space left between the beam ends is decorated with profuse number of the designs with pretty patterns. This portion though small in area of 15x15cms or at maximum 20x20 cms is used for the decorative purpose only, and thus called

DHALINKAWAS

meaning space between the beams. This part is often carved with the monosyllabic depiction of story from religious books and legends. This portion of the cornice is most inconspicuous part but is not left undecorated beautiful. Therefore Mary Slusser termed the portion as concealed cornice.

ANNEX 3

SUMMARY OF ARTIFACT RECOVERED

KASTHAMANDAP (MARU SATA:)

<i>Particulars</i>	<i>Previously existing</i>	<i>Recovered</i>			<i>Remarks</i>
		Usable*	Unusable	Lost	
Wooden frieze carved with the Saivo Buddhist story in four pieces	4	4			Some pieces of balustrade are flaked off (605 cm). It seems that frieze piece is not lost to be replicated anew - old one to be sent to museum
Wooden images of Bhairav	48	48			2 are completely broken, Some are cracked and effaced. 35 pieces are in good condition
Stone Icon of Gorakhnath	1		1		Broken into two pieces - to be replaced
Stone icons of Ganesh	4		4		2 of the with broken arms to be replaced
Pillars					
Big	4	3		1	
Small		30			
Meth					
Big		16			
Small		135			
Deco. Piece	2	2			
Copper Inscription		3			Recorded Inscription in copper

* *Directly usable or usable after repair.*

NAU DEGA (BIMALESVARA TEMPLE)

<i>Particulars</i>	<i>Previously existing</i>	<i>Recovered</i>			<i>Remarks</i>
		Usable*	Unusable	Lost	
Struts	24	24			
Corner struts	8	8			
Windows					
Gaa Jhya	16	16			
Yaku Jhya	8	7		1	Yaku Jhya have parts missing and 1 has only 2 pieces remained.

Doors	4	4			
Pillars	12	12			tenons to be refitted
Meths					
Full	8	8			
Half	8	8			
Chakulaan	12	9		3	3 of them are lost. 3 of them have parts missing
Dhalinkhwaas		more than 100			

* *Directly usable or usable after repair.*

The items from this temple is mostly saved.

PUN DEGA (TRAILOKYA MOHAN TEMPLE)

<i>Particulars</i>	<i>Previously existing</i>	<i>Recovered</i>			<i>Remarks</i>
		<i>Usable*</i>	<i>Unusable</i>	<i>Lost</i>	
Struts	24	15	9		Rest are fragmented.
Corner struts	11 (carved) + 1 (plain)	10 (carved)	1	1 (plain)	1 was already in plain timber before collapse
Windows					
Gaa Jhya	20	19		1	All partially damaged
Yaaku Jhya	8	8			
False Window	8	8			
Doors	4	4			
Pillars	20	20			tops and bottoms are to be redone
Meth					
Full	16	16			
Half	8	6			
Chakulaan	20	20			
Dhalinkhwa		more than 150			
Stone Icon	1	1			

* *Directly usable or usable after repair.*

Sizes in average:

Windows Top 100 x 180 cm, middle- 128 X 235 cm, bottom - 133 X 236 cm
Yaku Jhya at bottom storey only measuring 96 X 54 cm

Pillars: 25 x 25 x 190 cm in average.

Doors: 190 x 170 cm at the widest part.

False windows: 25 X 53 cm

MAJU DEGA

<i>Particulars</i>	<i>Previously existing</i>	<i>Recovered</i>			<i>Remarks</i>
		Usable*	Unusable	Lost	
Struts	48	33	13 [#]	2	2 are lost and rest are fragmented
Corner struts	12	11		1	9 still reusable
Windows					
Gaa Jhya	20	20			All partially damaged
Yaaku Jhya	14	14			
Doors	4	4			Some parts missing,
Pillars	20	20			Tenons in all of them have to be repaired.
Meth					
Full	16	16			
Half	8	8			
Chakulaan	20	20			
Dhalinkhwa		more than 150			
Stone Icon	1	1			

* *Directly usable or usable after repair.*

Although these pieces were unusable, some 30 fragments of these pieces were inventoried because of their high artistic value

Sizes in average:

Pillars 25 to 30 cm X 25 to 30 cm X 200 cm

Doors: Height 210 cm and breadth at the widest is 355 cm

Windows: Gaa Jhya central ones 110 X 210 cm, two in sides 100 X 175 cm
Yaaku Jhya measures 60 X 95 cm

SANTANESVARA TEMPLE

<i>Particulars</i>	<i>Previously existing</i>	<i>Recovered</i>			<i>Remarks</i>
		Usable*	Unusable	Lost	
Door	1	1			Base stone lost
Stone pillars	2		1	1	1 Broken and lost
Stone Icon	1	1			In Nhulachhen Chowk

* *Directly usable or usable after repair.*

GARUD NARAYANA TEMPLE

<i>Particulars</i>	<i>Previously existing</i>	<i>Recovered</i>			<i>Remarks</i>
		Usable*	Unusable	Lost	
Struts	40	40			Some rotten rest good. 6 are fragmented.
Corner struts	12	12			1 broken no more useful
Windows					
Gaa Jhya	20	19			Partially damaged
Yaku Jhya	8	8			Partially damaged
Door	4	4			
Pillars	16	16			Tops and bottoms are to be redone
Meth					
Full	8	8			
Half	8	8			
Chakulaan	8	8			
Dhalinkhwa		more than 100			
Stone Icon	1		1		Broken
Decorative Piece		7			

* *Directly usable or usable after repair.*

Sizes in average:

Doors: Height 170 cm X breadth 275 cm at the widest part

Pillars: 21 X 22 cm in average X Height 180 cm

Windows: *Yaaku Jhya* 62 X 36 cm, *Gaajhyaals*: bigger ones= 125x190, medium ones=115x180 and smaller ones = 117x75 cms.

CHYASIN DEGA (RADHAKRISHNA MANDIR)

<i>Particulars</i>	<i>Previously existing</i>	<i>Recovered</i>			<i>Remarks</i>
		Usable*	Unusable	Lost	
Pillars	24	24			Since this temple has no remarkably carved, no individual inventory is made, simply screened and deposited
Full Meth	16	7			
Half Meth	16	3			

* *Directly usable or usable after repair.*

As the restoration/reconstruction of this temple was undertaken before the inventorying of the recovered artifacts could be done and its artifacts were taken away to be reused.

SHIVA TEMPLE

<i>Particulars</i>	<i>Previously existing</i>	<i>Recovered</i>			<i>Remarks</i>
		Usable*	Unusable	Lost	
Struts					
Big	8	8			
Small	8	7		1	Few to be reinforced
Corner Strut					
Big	4	4			
Small	4	4			
Windows					
Gaa Jhya	8	8			Parts missing in some
Doors	1	1			parts missing, see inventory
Dhalinkhwaas	72	61		11	41 can be reused

* *Directly usable or usable after repair.*

BASANTAPUR TOWER (NAUTALE DURBAR)

Previously there were four three-bay windows (San Jhyah), four corner struts (kunsala), and sixteen long struts in the roof structure second from the top with sixteen additional small struts to support the bay windows all four sides. There were eight Yaka Jhyah on either side of four San Jhyah. Likewise, the topmost roof had four corner struts and twenty standing pillars that were supporting the grilled windows of a single piece spanning four sides of the structure. There were twenty small struts supporting the grilled windows.

One big and one small windows, which are assembled almost in complete state, along with 50 pieces of small individual images of gods, men, animals and other figures are recovered are placed inside shelter 3 below Bhaktapur Tower and behind the stairs at Lohan Chowk.

BHAKTAPUR TOWER

The whole structure of Bhaktapur Tower that stands above the terrace was almost a single entity with sixteen windows supported by sixteen main standing pillars with decorative carved sub pillars. There were 16 windows made into one piece spanning entire storey. Due to the fall from high place and members being thin and smaller in scale most of them are broken.

Note:

By the time the screening and sorting of artifacts from other temples was complete and only that of Basantapur Durbar and Bhaktapur Tower was left, it was found that these two towers were in precarious condition and it was risky to approach their upper stories. Hence some of the heaps that could possibly be in upper stories could not be reached. The team decided to gather whatever was accessible and approachable with less threat to human life. Hence not all of the items could be salvaged and it was left for future campaigns hoping that when the restoration of these towers will be undertaken, the items that could perhaps be in upper stories will be recovered. Thus, the artifacts from Basantapur Tower and Bhaktapur Tower could not be sorted completely. However, the following artifacts are recovered and stored in Shelter 3 and Lohan Chowk.

Shelter 3:	Struts (Large)	21
	Struts (Medium)	6
	Struts (Small)	17
	Corner Struts	3
Lohan Chowk	Struts (Long)	22
	Struts (Medium)	3
	Corner Struts	15

1. Kasthamandap (Balustrade)
2. Garud Narayan & Pun Dega (Windows)
3. Pun Dega & Maju Dega (Cornice)
4. Garud Narayan (Doors)
5. Pun Dega, Garud Narayan, Maju Dega (D/W)
6. Garud Narayan (Doors)
7. Maju Dega (?)
8. Mixed
9. Shiva Temple (?)
10. Garud Narayan (?)
11. Pun Dega (?)
12. Maju Dega
13. Maju Dega & Pun Dega (?)
14. Pun Dega (Windows)
15. Maju Dega (Windows)

Taleju Temple



Trishul Chowk

Mul Chowk

LOCATION OF ARTIFACT
STORED IN OPEN SPACE
(Date: November 2016)

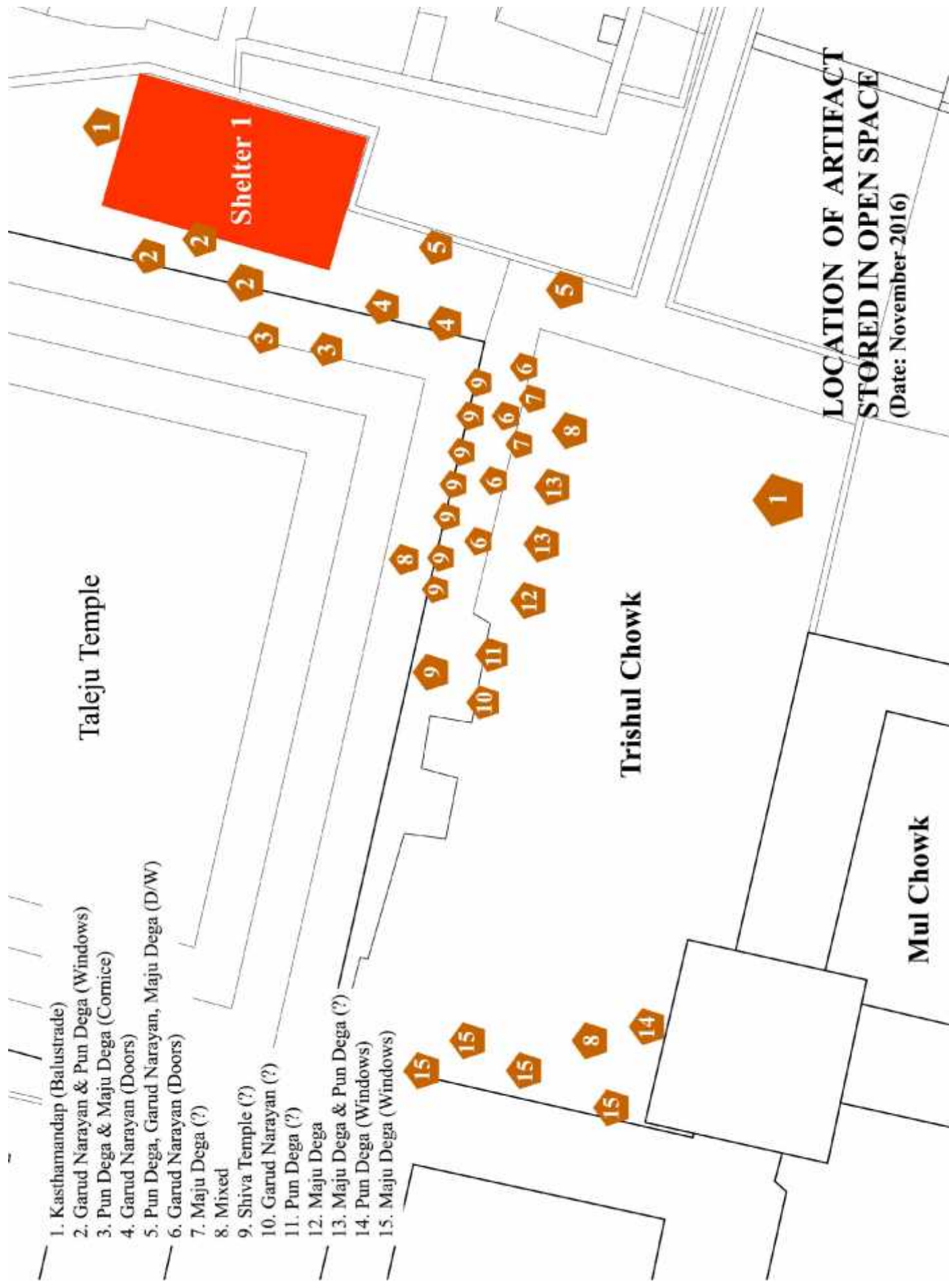

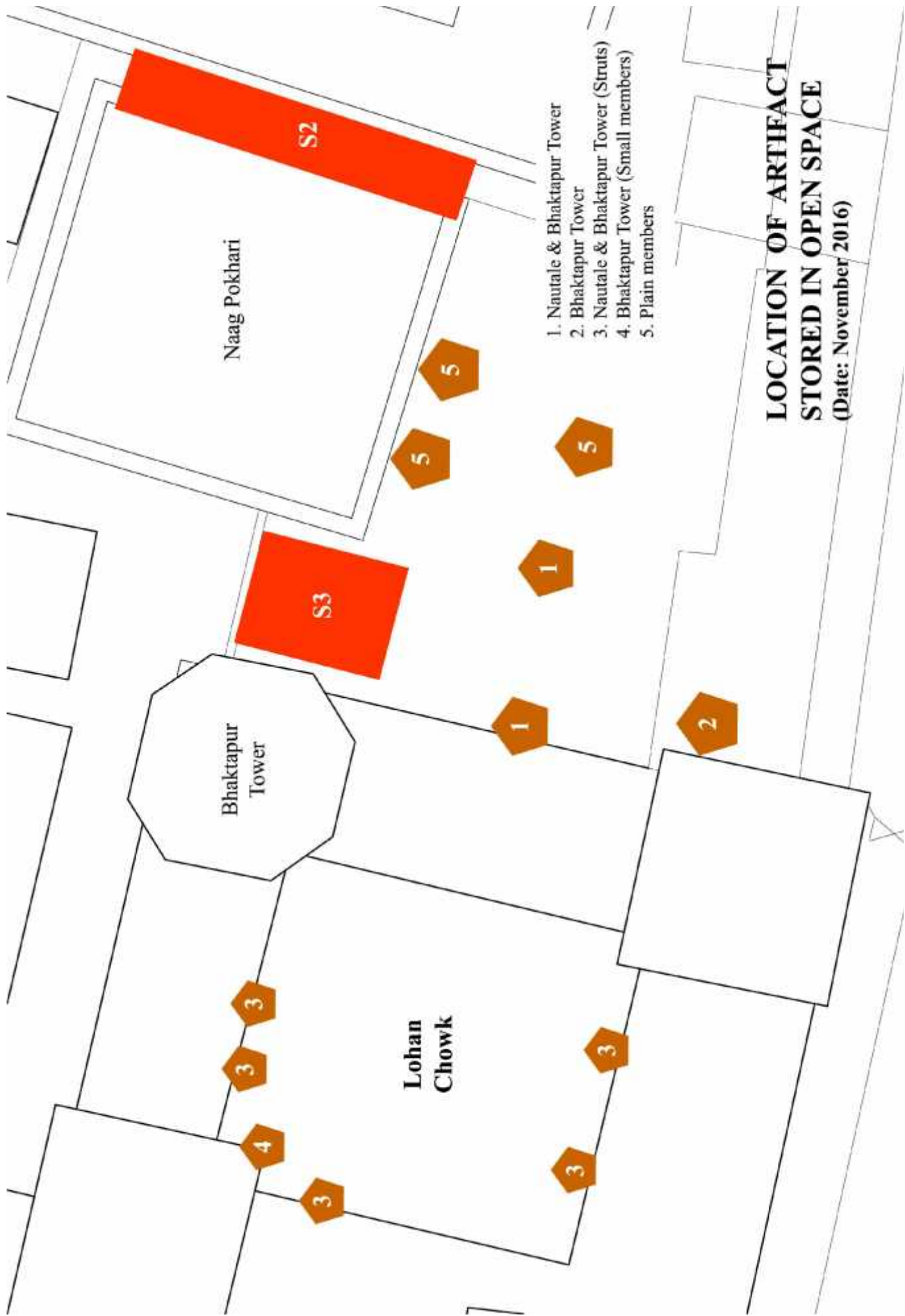

Naag Pokhari

S2

S3

Bhaktapur Tower

Lohan Chowk

- 1. Nautale & Bhaktapur Tower
- 2. Bhaktapur Tower
- 3. Nautale & Bhaktapur Tower (Struts)
- 4. Bhaktapur Tower (Small members)
- 5. Plain members

LOCATION OF ARTIFACT STORED IN OPEN SPACE
 (Date: November 2016)

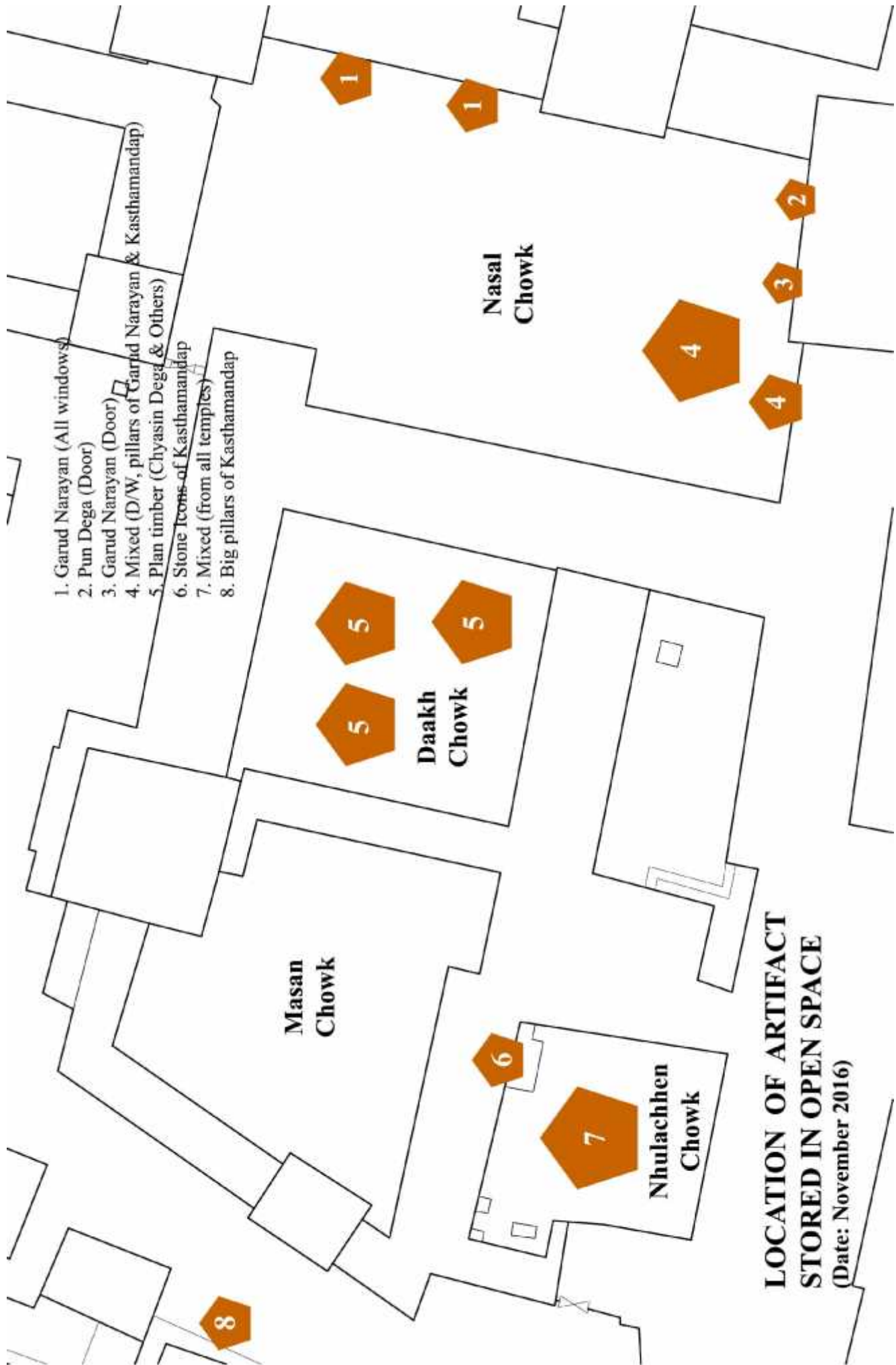

**LOCATION OF ARTIFACT
STORED IN OPEN SPACE**

(Date: November 2016)

APPENDIX 1

CULTURE SHEETS OF COLLAPSED MONUMENTS

Kasthamandapa (Maru Sata:)

Nau Dega (Bimalasvara Temple)

Pun Dega (Trailokya Mohan Temple)

Maju Dega

Santanesvara Temple

Garuda Narayan Temple

Chyasin Dega (Radha Krishna / Vamsha Gopal Temple)

Shiva Temple

Basantapur Durbar (Nautale Durbar)

Bhaktapur Tower (Laxmibilas Mandir)

CULTURAL SHEET
OF
KASTHAMANDAPA - A/K 197



A building with an unusual dimension of nearly 21 meters (64.75 feet) length, breadth and height stands at the western end of Hanumandhoka Palace Complex. The look is also unique in comparison to other temples surrounding the palace complex and though looks like a temple but not. It was a rest house made for the mendicants and travelers to and from Tibet and India. Therefore the building is called with the suffix *mandapa* that is Kasthamandap meaning rest house made of wood. Most important structure from which the name of the capital derived its name is a big square building known as *Marusatah* in vernacular, *Marusattal* in local community and more popularly by the name of Kasthamandap in academic writings. It is generally believed that Kathmandu the name of the capital derives from this building. *Kastamandap* means the pavilion made of wood.

This is the biggest *sattal* (or *pati* or an inn) among all the existing *sattals*. It has four entry points on the ground floor that is open from all sides. Right at the center four tall vertical wooden columns support the upper storeys and a stone statue of Gorakhnath is placed, four Ganesh of Kathmandu Valley also decorate the corners of this building. There are four pavilions on the four corners attached to the wall. These pavilions had as many as 48 Bhairavs and nice railings of carved wood. The western side had a wooden staircase leading to the second floor. The second floor used to have Porticos on all four sides. This floor also had four wooden columns to support the third floor.

The oral history credits king LaxminarshimaMalla for the construction of this building. The story of the heavenly wish granting tree *KalpaVrisha*'s visit to witness the chariot festival of *Matshyendranath*. Now some documents have proven that the building, *Kasthamandapa* stood in twelfth century.

Many cultural activities take place here like the exchange of Sword between *Pachali Bhairab* and the king. This building at the beginning was raised for public activities but from 14th century, this became the center of activities of Kapalikas hermits and they might have placed the icons of Gorakhanath. The traditional saying goes on to say that the inauguration ceremony of this structure has not yet been done. When the cost price of salt and oil would match or would be same amount then only the ceremony can be done on that day.

End Note: The structure was under the Guthi Sansthan until 1966 thenafter the renovation of 1967 the ownership was taken over by DoA.

Nomenclature: *Kasthamandapa* - from which the name of Kathmandu is derived.

Marusatah the vernacular name, the name itself does not show it a temple. It is rather a Rest House and shelter for the public's and travelers and mendicants.

Short Introduction: *The structure widely covers the ground area in terms of its architecture. The length, breath and height of the building is measured to 65 feet.*

There were 48 images of Bhaiavas in the balustrade of the Sattal surrounding the structure at the corners in ground floor. Each balustrade contained 6x6 Bhairav icons in each side thus totaling 48 in number. Six sets of Astabhairava icons are seen repeated because of the same figures are found in multiple copies.

In one of the balustrade in the east to the northern half has got an important frieze of nearly six meters long. The story is depicted on Saivo-Buddhist pantheon.

At the center of the ground floor stood an icon of Gorakhnath and at four cardinal directions are important four Ganesh in the name of Vinayaka supposed to be originated from four cardinal directions of Kathmandu Valley.

Date: Though it is said and written in many places as the creation of Laxminarashin Malla in 17th Century, the antiquity of the structure goes time behind 12th.century. Three copper inscriptions give more about the history. The name of the Kasthamandapa has gone up to NS 235 NS(1115 AD).

The salvaged items from this structure are:

- 1 Icon of Gorakhnath on stone
- 4 icons of Ganesh on stone
- 48 wooden icons of Bhairav (but two broken) used in the verandah on ground floor.
- 5.5 meters of illustrative panel used in the north half of eastern verandah in ground floor.
- 4 megapillars, one of them is broken,
- Meths (bracketts) half and full size have not yet been screened.
- 12 uncarved Gaajhyas have not been screened.
- All the timbers came out of this structure is arranged in Nhulachhen chowk.

Frieze of Kasthamandap



Id. No. A/K -197 Frieze 1

Name: Wooden frieze (*used in verandah in the northern half of the Eastern façade*)

Size: 7x594 cms. total of five pieces and thickness: 3(three) cms

Probable date: carved between 1630 and 1660 A.D(According to Niels)

Condition: Made of four pieces of planks in which the figures of stories from Buddhism and Saivism are carved nicely. By religious practice, the Newars of Kathmandu valley is defined as SaivoBuddhist people. This frieze is the best example of religious art created by Newars befitting the definition. The frieze could well be identified as pure invention of Kathmandu people's faith. Therefore the frieze remained a worthy representation of Nepalese art and culture which is a pictorial confirmation of the religious syncretism in Nepalese practice where the same deities, if under different names, are worshipped by both Hindus and Buddhists. Throughout the frieze the lingam neighbors the stupa and the Buddhist Nativity is juxtaposed with the holy Sivalingam of Hinduism.

It is divided into a succession of vignettes separated one from another with conventional renderings of trees, including palm tree. The vignettes almost certainly recount a divine Hindu and Buddhist story. The frieze is non sectarian in content and despite strong reference to Buddhist; it can be linked with Saivite as well.

The depiction of three important episodes in the life of Sakyamuni Buddha is: the impregnation of his mother queen Mayadevi, his birth in the Lumbini grove and his subsequent consecration.

The supreme Hindu god Indra though extinct in India by tenth century, mysteriously it was after that he appeared in Nepalese faith. Recognized in this panel by his distinctive single-crested crown, he appears in several panels. Due to too worn condition of the carvings his horizontal eye in the forehead could not seen in any of his figure. The frieze is filled with other many gods, goddesses and their acolytes and attendants followed by the shrines like stupas side by side with the Sivalingas being worshipped.(Mary Slusser)

Recommendation: The frieze is to be cleaned chemically and be put in the museum and the new one copied then be refitted in the temple.

(include some photos from my collection before earthquake)

Inventory of Inscriptions of Kasthamandap

INSCRIPTION 01

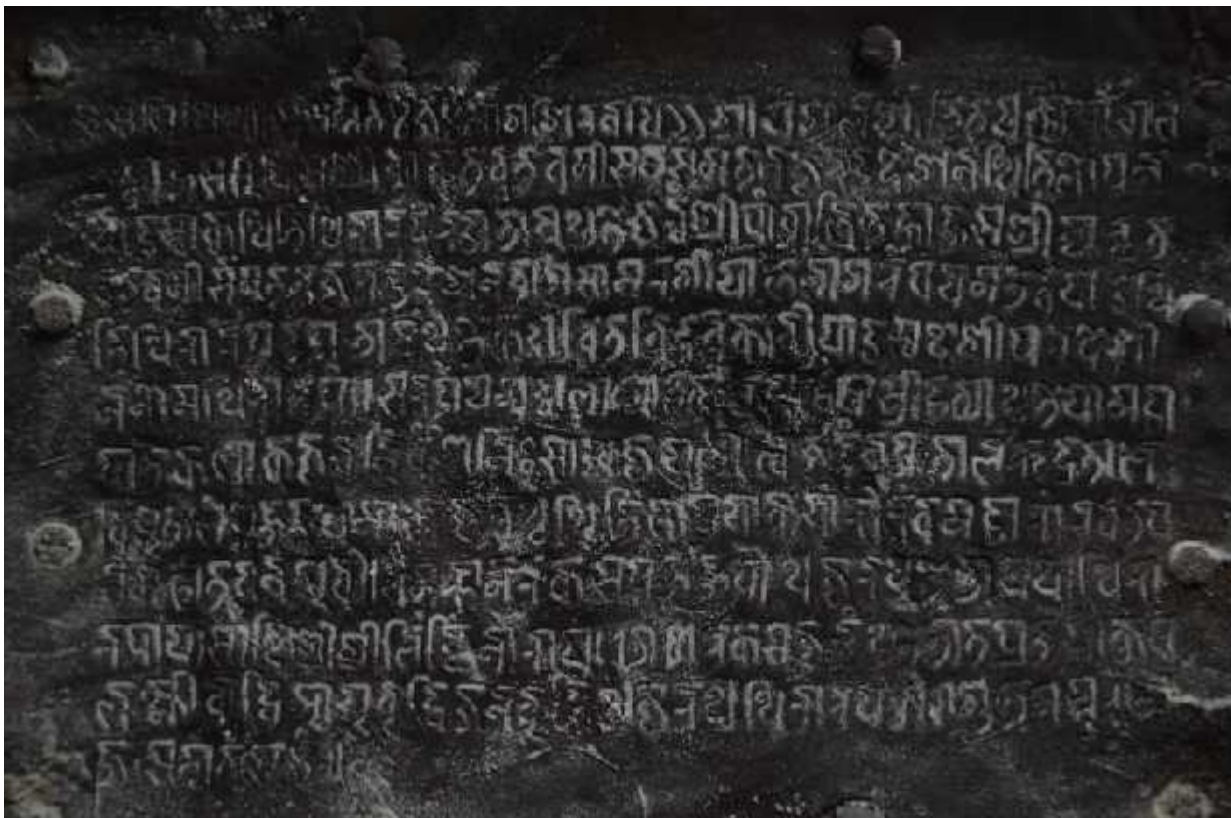

Id No. : A/K 197 Insc. 1

Size: 16x23 cms.

Material: Copper

Date: NS 454 (1352 A.D)

Script: Ancient Newari

Subject contained: *A Workshop building is built during the reign of three brother rulers in the land of Phachali Bhairava.*

Epigrapher: Shyamsundar Rajvamsi, Chief Epigraphist of Dept of Archaeology.

A synoptic translation of the copper plate inscription of NS. 454

Hail ! On the eleventh day of bright fort night of Mangsir of N.S. 454(Nov-Dec. of 1334 A.D), the three brother Mahapatras(the local rulers) should in the sacred land of *Pachali Bhairava* this building (should be used) for (all purpose).

To whom it may concern and related and who has donated should be consulted and come into mutual agreement not to discontinue what had been done in early time. The all should be continued. All the rituals pertaining to Pachali Bhairava should be continued by the respective persons. To those who create troubles either by locals or by the outsiders should be put into the code and be punished as the punishment of the five heinous crimes.

The dances of *Brahmatal*, *Rudratal*, and *Vishnutal* should be staged for four days. If this dance is not performed the responsible persons will be punished and will have to spend four days in mega hell of *Abhichi*. The witness is *Linchhinarayana*. Those who perform everything as mentioned in this (great paper) will be rewarded with the increment of the wealth, good health and long life. With this good deed may all be prosperous in the world.

INSCRIPTION 02



Id No. : A/K 197 Insc. 2

Size: 9x29 cms

Material: Copper plate

Date: NS 499 (1379 A.D)

Script: Ancient Newari

Subject contained: Order of King Jayasthiti Malla not to discontinue but to perpetuate the processional festival of *Harisana* done every year in Yambu- the upper part of old Kathmandu city.

Epigrapher: Shyamsundar Rajvamsi, Chief Epigraphist of Dept of Archaeology.

Synoptic translation of the copper plate inscription of NS. 499

Om Hail ! On the second day of bright fortnight of Baisakh of Nepal Era 499(April/May 1379 AD) this is the royal command of King Jayasthiti Malla not to stop but to keep continued the rituals and the processional festival of Harisana of Yambu that was coming

down from history. All the responsible persons should act according to their respective duties.

The acts should be done on the witness of Yogmati Bhattarika and she will be helped by Sivakara and other respective donors.

If not done properly they will be punished after their death according to three heinous crimes of killing wife, children and a Brahmin and if done accordingly will be prized with the happy life in heaven.

INSCRIPTION 03



Id No. A/K197 Insc. 3

Size: 14x30 cms

Material: Copper plate

Date: NS 543 (1423 A.D)

Script: Bhujinmola

Subject contained: Mentions about the rituals and festivals to keep continued and talks about the ownership of the structure (Kasthamandapa) to three Mahapatras of Patan including Kantipur.

Epigrapher: Shyamsundar Rajvamsi, Chief Epigraphist of Dept of Archaeology.

Synoptic translation of the copperplate inscription of NS. 543

Hail ! On 10th. of bright fortnight of Asadh of NS 543 (June/July 1412 AD) This is the command of the King Joytirmalla not to stop all the rituals and festivals that was being

observed since long time in Patan and Kantipur but should be kept continued. This is the royal command that is promulgated by King Jyotirmalla and if not observed at prescribed those responsible will accrue the punishment. If kept continued everybody n the society will accrue merit.

Let all be prosperous.

CULTURAL SHEET
OF
NAU DEGA (BIMALASVARA TEMPLE) - (B/K 196)



A medium size two storied temple stood to the north west of Kasthamandapa named Bimalaswori Shiva. The full name of the temple was Bimalaswari Visweswari temple recorded in the manuscript. But to the local people it is famous with the third name Nau Dega (the temple of barbers). The plinths of the temple were occupied by the barbers to provide their service to the clients in olden days thus the name.

The temple stands upon a three tier plinth with a stone bull to its west. Twelve vertical pillar and spine wall support the entire structure. The four entrances on four directions like other Siva temple have added the beauty of the structure. The temple housing a Sivalinga has always four doors in four sides so that a devotee can see and pay homage from all sides. All four facades in ground floors have elaborately carved doors. On both sides of the doors is decorated with Yaakujhyaals. Similarly on first and second roofs have Gaajhyaals at the centre followed by two Gahjhyaals in each side. *(One has to be cautious here not to be confused with the nomenclatures of the windows- Gahjhyaa and Gaajhyaa. They are two different types of the windows and Yaakujhyaa is an another type. This temple has three distinctive types of the windows. Please see in the pictures particularly.)*

Sixteen struts representing various Bhairavas all having Kapala and Vajra mudra are nicely depicted. The upper eight struts have the carving of eight mother goddess all having vertical third eye in their forehead. Almost all the struts have been preserved and placed in a shade for protection. The doors and the struts can be reused after small repair work.

The temple was erected by a man named Chakrasinha on the name of his father Visvesvara and his uncle Bimalesvara. But name remained only on the name of Vimalasvara forgetting the name of Bisvesvara. The real name or full name was VimalasvaraVisvesvara temple. But in course of time it became Naudega. Once the barbers occupied the plinths of it to provide their service to the clients to earn their breads the local people started to call Naudega, the temple of barbers. The temple was made couple of years after 1871 A.D. Therefore could be written in the decade of 1970s.

All wooden members of this temple are salvaged. Except the bricks and stones almost everything on wood is salvaged from this temple and preserved storing on the shade to the east of Nagapokhari that was made available by UNESCO.

Nomenclature: The people call it as *Naudega* because the plinths of this temple were occupied by the barbers to offer their service therefore the name. *Nau* means barber and *dega* means the temple (therefore barbers sit for their profession of providing the service to their clients Naudega)

Date: 1870's A.D.

Donor: Mr. Chakra Singh made the temple on the name of his father Visvesvara and uncle Bimalesvara

Short Introduction: *This was one of the temples the wooden parts of which are mostly intact with finest wooden members. All the parts are nearly intact with exception of about 5 to 10 % damages.*

End Note: Completely grounded to the plinth therefore has to be re-erected after renovating the entire plinths.

(This is not to be confused with a temple of same name (Naudega) that stands to the south east of Bhedasingh in Indrachowk.)

The items salvaged from this temple are:

The Doors	4 nos. (all without base one is main entrance but looks similar. The base stone was made of stone that are in situ.)
The Pillars	12 nos.
Chakulaan (Square Tops)	only 9 are found. (out of them, 3 are broken).
Meths (Brackets)	16 nos.
Cornice	Carved beams of entablatures amounts to nearly 50 pieces of different lengths.
Struts	Long ones of upper roof - 8 nos., short ones of lower roof - 16 nos.
Kunsala (Corner Struts)	long ones of upper roof - 4 nos., short ones of lower roof - 4 nos.
Windows	Big 8 Gaahjhyaa (?), Medium 8 Gaajhyaa (?), Small 8 (yaakujhyaa) having icons in the center but icons remains only 7. Among seven Yaakujhyaals, only three are complete, 4 have some parts missing.
Dhalinkhvas (Concealed Cornice)	140 Dhalinkhvaas and four corner dhalikhvaas are there. These are from the lower roof. Small size dhalinkhvas numbers to 72 with 4 corner dhalinkhvaas were from top storey.

CULTURAL SHEET
OF
PUN DEGA (TRAILOKYA MOHAN TEMPLE) - B/K 202



In front of Gaddivaithak and to the north of the official residence of Kumari (the living goddess) stands the famous temple of Trailokya Mohan Narayan. This temple was raised in memory of Nripendra Malla in the year 1681 AD. The temple is raised on the five tiered diminishing plinth. During Indraajatra the story of all ten incarnations of Vishnu (in drama is staged) on the eastern side of the temple. So this is known as Dasavatar temple also. The Chitrakars (traditional painters) used to paint this temple so is also known as Pun Dega.

The vertical wooden pillars separate the circumambulatory passage. It has four doors but the main door is faced toward west. The Garuda facing to the temple was offered only in 1690 AD that stands on the west of the temple.

A small square raised platform Gaddi Dawali. There was a tradition up to 1952 that nobody could step and pollute the platform. If somebody does this offence, he or she would have to carry ten loads of water from Maruhiti and clines the platform. All the struts can be reused after fixing the lost hands. It seems that this temple was heavily damaged in the earthquake of 1934 also. Many supporting struts were replaced or simply wood was placed. In total there are twenty struts that have been found representing various Vaishnava deities, gods and goddesses.

Nomenclature: *Pun Degah* in vernacular. (There is a legend in calling so)
Dasavatara dekhaune deval by the hill people
Trailokyamohan Mandir, inscribed name,

Date of Construction: **N.S. 790** (1680 AD)
 Garuda added in 1689 AD
 Renovated in 1934 earthquake and again in 1970s

Raised on a five plinths, this is the first conspicuous Nepalese temple seen from the east while going to the Durbar Square. The temple faces west and Garuda standing in front of the temple is one of the master piece stone arts of Nepal carved on a single stone. The temple was made in the name of Nripendra Malla immediately after his death.

End Note: The temple was completely destroyed above the plinths and has to be re-erected above after renovating the plinths also.

The salvaged objects from the temple are:

Kunsala(corner struts)	3 nos.
Struts	24 (?) nos.
Pillars	20 nos.
Gaajhyas	20 nos.
Yakujhyas	8 nos.

CULTURAL SHEET
OF
MÄJU DEGA - B/K 191



Right in front of the entrance of *Gaddi Baithak* to the northwest corner of Trailokya Mohan Narayan stands this temple on a tall nine diminishing plinth. This was the third tallest temple in and around Hanuman Dhoka Durbar Square. Queen Riddhi Laxmi Devi, the mother of King Bhupalendra Malla erected this in the year 1690 AD. As the temple was raised by queen mother it was called *Maaju Dega* because honorable mother is called *Maaju* in Newar language.

No matter size, or the height of the temple the plinth, wooden struts, entrances in all four sides are of large size. It was a three storied temple with tile roofing. On the upper plinth sixteen vertical wooden pillars separated the circumambulation path. Like other big Siva temples of Kathmandu the sanctum has a huge Sivalinga and four entrances are on each direction.

The struts here on all the three stories $6-4-2=48$ has erotic carving at their base.

The finial or pinnacle was very simple here designed as a stupa may be this happened during previous reconstruction after many earthquakes.

In front of the staircase leading to the temple used to have a white *sikhara* temple of *Kaamdeva* that also grounded to dust. Only one stone pillar and door of that is salvaged.

Nomenclature: Though this temple is dedicated to *Sivalinga*, the people call it as *Majudega* because it was established by Queen mother Riddhi Laxmi the mother of Bhupalendra *Malla*. *Maaju* means honorable mother in Newari. It remained to the tongues of other people for ever, thus *Majudega*.

Short Introduction: *This is an independent temple raised above nine stepped plinths at the center of the western part of Hanumandhoka Palace complex. Having three roofs profusely decorated with the erotic sculptures in the struts, and the wide open space looking all around the squares and its height of nine plinths the place is a magnet for the people to take a nap or enjoy the entire environment. The climatic condition is also superb. Cool air breezes during the days of summer. And, the place remains whole day sunny during the winter. Therefore the porch, surroundings and plinths are seen always filled with the visitors- national and foreign tourist.*

There are 40 struts in total used in three roofs. Though the size of the roofs differs, the length of them is equal in size. The sizes vary from 15x30x215 cms. and 15x30x90 cms. in average. The positioning of long and shorts struts should have adjusted with an addition of wooden support that is called in Newari(again) Laakaansin. It is used where the struts rests on the twaakah.

Almost every Tunal has got the erotic carving in lower one fourth part of its length. The subject and fantasies are enormous. All sexual fantasies that were heard off in the society then are carved on those 40 Tunals. For men women simply exhibiting their erected phallus to the acrobatic sex are carved on them. But one this is absent on these is an animal sex. No bestiality is portrayed here in. From the study of carving it is well noticed that the main figures were carved by the master carvers and other acolyte figures are often fount cut by the apprentices. The intricacy of carving on them is well discernible. Unlike on other erotic tunaals, the main figures do not directly step on the heads and shoulders of the caryatid figures. The main figures simply stand on a lotus flower below which are the figures of their vehicles (vaahanas) then only after that comes the compartment of sexual figures separated by the rocky patterns.

Date of construction : N.S. 810 (1690 A.D). The inscription is at the northern façade.

End Note: The temple above the plinths collapsed making it just the heap of the debris.

CULTURAL SHEET
OF
SANTANESVARA TEMPLE - B/K 191(b)



A Sikhara style structure erected on brick with lime plastered in white color stands right in front of the steps leading up to the sanctum sanctorum of Majudegah. The temple was empty however there was an icon of Kamadeva in the back of the structure before the earthquake. Therefore everybody calls this *sikhara* to be Santanesvara temple,

The temple was made on the spot, as the local Joshi families believe, where Laxminarayana was slain. His family made this temple and named it as Laxminarayan Muktesvara temple. There was an icon in a niche above the door that is of Mrityunjaya followed by second one of Kamadeva on the back of the temple.

Joshidega and this temple was made on the name of Laxminarayana family before and after the death of Laxminarayana, therefore Joshidega is

called Bhaktesvara and this one is Muktesvara temple dedicated to Siva.

The temple is totally grounded during the recent earthquake.

Only one door is salvaged that is stored in the shade provided by UNESCO to the east of Talezu temple. Though bit eroded in the patterns of carving, the door is completely reusable but should be cleaned either by sand blasting or by soda water sash.

Nomenclature: Very few people know about the name of this temple. The temple was empty but an icon of Siva with erected phallus was in a niche behind, thus is called as *Santanesvar Mahadev*

Date of construction : 17 th. century

Short Introduction: *This is the only sikhara temple in the area and tiny in size, therefore very few people notice about it. The temple is no where recorded.*

End Note: Completely grounded therefore has to re-erect.

CULTURAL SHEET
OF
GARUD NARAYAN TEMPLE - B/K 189
(West of Shiva Parvati temple)



A beautiful three storied Garud Narayan temple stood to the North of *Maju Dega*. The temple was raised in three plinths. The sixteen struts in the first roof are, all of, sixteen male *Vaishnavite* deities. The base of them has a series of carving showing the Royal activities. The sixteen struts in the middle stand on a pair of birds, the figure are both male and female. The upper or last roof is supported by small size struts of Krishna in various activities like playing flute and playing with *Gopinis* carrying milk, yoghurt on their heads. The series of the activities continues here also. Also all the struts can be used fixing the missing hands.

This is one of the least studied and least reported and least photographed temples among the temples in the Durbar Square.

Nomenclature:	Narayan temple (sometimes also called Laxmi Narayan Temple). But the actual deity inside the temple is of Garud Narayan.
Date of construction :	The temple is said to be erected by Laxmi Narayan Joshi in 17 th .century
Short Introduction:	<i>This is the least studied and reported temples in the palace complex despite its beauty and grandeur. The temple stands to the right of Shiva Parvati temple having three roofs.</i>
End Note:	Has to be completely re-erected above the plinth. Most of the struts are still intact and can be reused with minor repairs.

The objects salvaged from this temple are:

Pillars	16 nos.
Yaku Jhya	8
Gaa Jhya	19 (1 lost)
Struts	40
Kunsalas(corner struts)	12
Meth (Full)	8
Meth (Half)	8
Chakulaan	8
Dhalinkhwa	105
Stone Icon	1

CULTURAL SHEET
OF
CHYASILIN DEGA - B/K 181



King PratapMalla raised this unique octagonal temple in the year 1648 AD. The king was married to many queens. His two queens Rupamati Devi and Rajmati died at an early age. So in their memory he raised this temple dedicated to Krishna along with Satyabhama and Rajamati. A replica of king himself and his two departed queens are represented in the main icon itself. This is an octagonal temple raised on five plinth. The main entrance was facing east. A stair leading to the sanctum was cut on the middle of plinth from eastern side. Two artistic stone pillar were raised in front of the temple one with Hanuman and other one lost. The struts were of serpentine shape and are in simply plain wood. Many wooden objects have been preserved, but needs rework on them.

Nomenclature:	Because of octagonal in shape the local people call it as <i>Chyasilindega Radhakrishna mandir</i> because the temple contains the icons of Krishna with his two wives <i>Rukmini</i> and <i>Satyabhama</i> .
Date of construction:	N.S. 769 (1649 A.D)
Short Introduction:	The temple was not in true to its shape also before the earthquake only octagonal in shape with three roofs was maintained. The artistic grandeur was already gone long before probably during earthquake of 1833 already.
End Note:	The superstructure is completely collapsed leaving its dilapidated plinths. Therefore it has to be completely reraised. The reconstruction of this temple has already started.

The items salvaged from this temple are:

Full Meth(brackets)	7 nos.
Corner Meth	3 nos.
Parts of Carnes pieces	111(directly reusable 6 nos., reusable after repair-93 nos. unusable - 12 nos.
Nagbeli pieces	23 nos.(Reusable after repair)
Chakulan	5 (reusable after repair 4 nos. and one unusable)
Dhalinkhvas	26
Pillars	24 nos.(reusable after repair).

CULTURAL SHEET
OF
SHIVA TEMPLE - C/K 155
(in front of Simhadhoka)



On either side of the Simhadhoka of Taleju complex stood two beautiful small pagoda temples dedicated to Siva. Both seventeenth century temples though in smaller scale were standing to the right and left sides of Simhadhoka and were in dilapidated condition at the end of the 20th. Century. With generous donation of US Ambassador's fund, KVPT restored both completely to its original shape and size in 2007. But the southern one could not stand the great earthquake of 2015 and almost leveled to the ground. Though small a temple, it has most artistic wooden members in the structure. The struts bear instead of erotic scenes the social pictures at the bottom belonging to the period. The central portion bears the main figures of Siva and other mother goddesses. Located almost at the front base of

Talezu in western side, the two temples were adding the beauty to the Talezu temple along with its main entrance Simhadhoka that accentuates the historic and cultural value to entire western façade. It seems most probably that the triumphant king Pratap Malla brought two lions and Simhadhoka confiscated from Bhaktapur and reerected them in western side of Talezu temple base. It seems these two temples were also constructed during that period. The temples still were retaining their original configuration with many of their original details intact. These fine examples of traditional temple architecture of Newars could not stand the last earthquake. The result, southern one was leveled to the ground and northern still remained standing with all walls broken.

However, many of the wooden members are safe that are salvaged, inventoried and stored in different parts of the Trisulchowk. We cleaned the debris and found many things that we salvaged and catalogued.

Nomenclature:	The temple has no specific name simply called <i>Siva mandir</i> .
Date of construction:	N.S.600 to 700 (16/17 century A.D)
Short Introduction:	<i>Though small in size the temple adds the additional beauty and value to the palace square. The wood carvings ismall temple is noteworthy from quality and expression of the subjects of the contemporary society. A barber providing his service to a client is the master piece wood work of the 17th.century Nepal. The temple was lastly renovated by Kathmandu Valley Preservation Trust (KVPT)in 2006 with US Ambassador's fund but unfortunately the structure could not be survived. Most of the wooden members still can be reused with some additions.</i>
End Note:	Completely grounded therefore has to be re-erected.

We have been able to find and preserve the following timber objects:

Windows:	8 nos.(Parts of the window carvings missing)
Struts (big and small)	15 nos.(Just one missing)
Corner Struts (Kunsala)	8 nos.(All are OK but some has to be reinforced.)
Door (Entrance)	1 nos.(Parts of the carved members missing.)
Carnes	18 nos.(pieces in total)
The base of pinnacle (finial)	1 nos.(not complete- broken)
Dhalinkhwa	61 nos.(comprised of lion and griffin faced)
Dhalinkawa	10 nos.(being small in size, they are lost)

The struts of this temple and the carving on their base are very interesting, showing the market place, a barber shaving the rich (or an aristocrat client) group dance and so on.

We must say that we are proud to salvage the wooden elements of this beautiful temple. Most of pieces can be reused after some minor repair works.

CULTURAL SHEET
OF
BASANTPUR DURBAR - A/K 164



The famous Nautale Durbar stands on the southern end of Nasal Chowk. The inscription at the main entrance of Nautale from Nasal Chowk has a stone sculpture of Ganesh. The inscription is a kind of eulogy of Prithivi Narayan Shah and his construction of Basantapur Palace from the year 1769 AD. The inscription describes in detail how he defeated his powerful enemies like rulers of British India and the Islam ruler Mirkasim. The inscription facing Basantapur mention both the queens and two sons of P. N. Shah. Just above the entrance are a big screened window and many attractive struts. It has three other tall buildings locally believed to be raised by the artists of Patan, Bhaktapur, Kirtipur the tallest one being built as Basantapur palace. The upper part of palace was destroyed in the earthquake. To the west of Nautale is a building built in western style proving that it was added later on. Nasal Chowk to the north of Basantapur has many Cultural activities like BasantaSraavan. As per the local saying King PrithiviBirBikram was born here. He was married with the daughter of VirShamser and he then shifted

to Narayanhiti Palace. A nine storied building was raised by MahendraMalla (story?). Many part of Lohnchowk, the roofings have fallen down but the artistic timber elements have been preserved as much as possible and palced properly. In Nasal Chowk, to the north of Basantapur palace or Nautale the tradition of “giving an intoxicated male buffalo” “BhakkulaiRango dine” was done up to 1952. All the shah rulers from Prithivi Narayan Shah to Surendra stayed in this building. To the west of Nautale and Nasal Chowk Jung Bahadur after he rose to power constructed white lime washed building for a comfortable residence to his daughter and son-in-law crown prince TrailokyaVirkram Shah. King PrithviVirvikram Shah, the great grandfather of the last king Gynendra was born in this building and he shifted to Narayanhiti Durbar at the age of 10. They live in this building during Indra Jatra from 2 nights to 7 nights.

Nomenclature: Basantapur Durbar. The structure is also called Nautale Durbar because of it having nine storeys.

Date of construction: 1770/71

This tallest structure in Hanumandhoka Durbar Complex is also called Kailash. This was the first structure completed during the life time of King Prithvinarayan constructed along with the Vilas Mandir also called Lalitpur tower.

There is a legend that the four towers were assigned to the people of four cities in Kathmandu valley Kantipur, Patan, Bhaktapur and Kirtipur in four corners in order to win their confidence.

First the Kailash and Vilas Mandir were erected and then Bhaktapur and Kirtipur towers added later.

Though looked like a temple structure, it is purely designed for palace building. The structure was square in initial phase but transformed into rectangular shape after the great earth quake of 1934. A photo snapped in 1910 shows this situation. However the topmost floor was in rectangular form running east to west.

The building was constructed purely for residential purpose for the king and his family. So this was a secular building not a temple.

Being a residential building, this is most dirty structure in terms of erotics used in the struts and strutlets. Almost all varieties of eroticism are depicted in this structure.

Endnote: Top two roofs have to be raised anew.

CULTURAL SHEET
OF
BHAKTAPUR TOWER - A/K 166



Among the four towers in Basantapur Durbar top portion of two towers could not survive the earthquake. Two top two roofs of Nautale Durbar portion are gone and top portion of the Bhaktapur tower above the struts is also pulled down during the devastation. This portion of the tower is also called *Laxmivilas mandir* an unusual name for a residential building.

This structure was raised in sixteen angle plan and having sixteen windows placed in all sides that could be opened and shut but all of them were in grilled fashion. When the windows were closed no one can guess they could be opened.

Even the roof structure is made accordingly. The dividing line of the roof base provided by *upa* bricks is also interestingly patterned. A great task has come to the hands of the conservational engineers and architects to rebuild the roof structure of this building. This would be a challenge and lesson also for the future generation.

Due to the small size and thin wooden members used in the structure, most parts are broken when they were fallen from the height of almost seven storey above. Whatever were left on

the were also thrown off from there and ultimately much of the wooden members fell apart breaking into pieces. Very few parts will be possible to reuse.

However they are screened and stored in the shade attached to the building in the east. Inventory form is not filled.

Nomenclature:	The aristocrats call the structure as <i>Laxmivilas mandir</i> though not a Temple. General people understand it as <i>Bhaktapur</i> tower. It is said that the structure was made by the people of Bhaktapur.
Date of construction:	N.S.889/894, (1779 to 1775 A. D)
Short Introduction:	Durbar Complex that stands at the northeast corner of the complex. It is a unique structure having its octagonal shape in plan and roof structures also. The whole structure looks charming The Bhaktapur tower is one among the four towers of Basantpur Durbar seen from all sides with the windows grilled but could be opened and shut. This was a maze structure on wood.
End Note:	The verandah portion is completely fallen down above the tiny struts still intact. The portion could be re-erected using at least 30% of its old wooden members.

APPENDIX 2

INVENTORY SHEETS OF COLLAPSED MONUMENTS

Kasthamandapa (Maru Sata:)

Nau Dega (Bimalasvara Temple)

Pun Dega (Trailokya Mohan Temple)

Maju Dega

Santanesvara Temple

Garuda Narayan Temple

Chyasin Dega (Radha Krishna / Vamsha Gopal Temple)

Shiva Temple

Basantapur Durbar (Nautale Durbar)

Bhaktapur Tower (Laxmibilas Mandir)

KASTHAMANDAPA (MARU SATA:) (A/K-197)

01. Copper Inscriptions

02. Panels

03. Wooden Icon

04. Pillar

05. Meth

06. Decorative Piece

07. Stone Icon

INSCRIPTION 01



ID No.: A/K 197-INS 01

Size: 16 x 23 cm

Material: Copper

Date: NS 454 (1352 A.D)

Script: Ancient Newari

Subject contained: A Workshop building is built during the reign of three brother rulers in the land of Phachali Bhairava.

Epigrapher: Shyamsundar Rajvamsi, Chief Epigraphist of Dept of Archaeology.

काष्ठमण्डपको तामापत्र नाप २३ सेमि ल. १६ सेमि चौ.

- १ ऊं स्वस्ति श्रेयास्तु ॥ सम्वत् ४५४ मार्गशिर वधि ११ श्री यंगल श्री त्रिभय छयं पांचालि
- २ भद्दाहस सुदिस श्री ज्याछु तव तवमीसन समतन जुर उदेशन थितिलोपन
- ३ याडं म्वाक्व थिति थिरारप रडां भाष थ्वते जुरों श्री पांचालि भद्दाहस श्री ज्याछूं त
- ४ व तवमी संमतन जुर उदेशन दृगि सामरगी याके लागरप यमते याडं थि
- ५ ति थिरारप रडां भाष थ्वते कदाचित विदवकारी याडं स्वदेशी परदेशी
- ६ न नोम थिरारपं ध्वंसरपं यग्वद्वालय गो हथ्या ब्रम्ह हथ्या स्त्री हथ्या थ्वतेया महा
- ७ पातक लाक्व जुरों । निर्वंश निःसाख जुयमाल्व जुरों ब्रम्हताल रुद्रताल
विष्णुताल पेन्हु न्हुय माल्व जुरों थ्वथिति लोप याक्वया रौरव महारौरव तप
- ९ न महातपन अवीचि महानरकस पेन्हु न्हुपौथ जुर थ्वते भाषया थिरा
- १० रपाया साक्षि श्री श्री लिंछिं नारायण भटारकस जुरों थ्वते तातप्रज याक्वस
- ११ लक्ष्मी वृद्धि आयु वृद्धि जन वृद्धि थजुर थ्व थिरारपे क्वोस शुभमस्तु ॥ ॥
- १२ जत्सत्यं तत्सुभं ॥

भावार्थः

कल्याण होस् ।नेपाल संवत् ४५४(वि.सं १३८९) मार्गशिर वदि ११का दिन श्री यंगल,श्री त्रिभय महापात्र एवं श्री पांचाली भद्दाहस(पचली भैरव)को पवित्र भूमिमा कार्यशाला भवन बनेको भयो । जो जसको यसमा योगदान छ उनीहरुले सहमत भएर चल्दै आएको थिति लोप नगरियोस् भन्ने उद्देश्यले यो स्थिति बन्दोवस्त गरियो । यसको भाषा यो छ कि श्री पचली भैरव कन जुन जुन कार्य राखिएको छ । जो जो यसमा सहमत छ उसले त्यो उद्देश्य पुरा गर्न चाहिंदो सरसामान जुटाउने काममा कुनै बाधा नगर्नु भनीकन यो स्थिति बन्दोवस्त गरियो । यसको अर्को भाषा व्यहोरा यो छ कि केही गरि वितण्डाकारीहरुले बेथिति बनाइ दिए भने उ चाहे स्वदेशी होस् वा विदेशी होस् उ पनि स्थिति बन्दोवस्त ध्वंस गर्ने दोषी मानिने छ तिनीहरुलाई गोहत्या ब्रह्महत्या स्त्रीहत्या जस्ता महापातक लागोस् । साथै वंशहीन संपत्तिहीन समेत हुनु परोस् ।

ब्रह्मताल, रुद्रताल, विष्णुताल का नाच चार दिन सम्म पुरा नचाउने प्रवन्ध मिलाउनु प यो । यो थिति बन्दोवस्त लाई लोप गरे भने रौरव, महारौरव तपन महातपन जस्ता अवीचि महानरकमा चार दिन चार रात रहनु परोस् । यो भाषाको स्थिति बन्दोवस्तका साक्षीमा लिंछिंनारायण भट्टारक छ यो

बन्दोवस्तमा भनिए जस्तो गरि कार्य गरियो भने लक्ष्मीवृद्धि, आयुवृद्धि, जनवृद्धि समेत होस् । यो स्थिति बन्दोवस्तबाट सबैको शुभ होस् जेजति सत्य हो त्यो शुभ हो ।

A synoptic translation of the copper plate inscription of NS. 454

Hail ! On the eleventh day of bright fort night of Mangsir of N.S. 454(Nov-Dec. of 1334 A.D), the three brother Mahapatras(the local rulers) should in the sacred land of Pachali Bhairava this building (should be used) for (all purpose).

To whom it may concern and related and who has donated should be consulted and come into mutual agreement not to discontinue what had been done in early time. The all should be continued. All the rituals pertaining to Pachali Bhairava should be continued by the respective persons. To those who create troubles either by locals or by the outsiders should be put into the code and be punished as the punishment of the five heinous crimes.

The dances of Brahmatal, Rudratal, and Vishnutal should be staged for four days. If this dance is not performed the responsible persons will be punished and will have to spend four days in mega hell of Abhichi. The witness is Linchhinarayana. Those who perform everything as mentioned in this (great paper) will be rewarded with the increment of the wealth, good health and long life. With this good deed may all be prosperous in the world.

INSCRIPTION 02



ID No.: A/K 197- INS 02

Size: 9 x 29 cm

Material: Copper plate

Date: NS 499 (1379 A.D)

Script: Ancient Newari

Subject contained: Order of King Jayasthiti Malla not to discontinue but to perpetuate the processional festival of Harisana done every year in Yambu- the upper part of old Kathmandu city.

Epigrapher: Shyamsundar Rajvamsi, Chief Epigraphist of Department of Archaeology.

काष्ठमण्डपको तामापत्र नाप २९ सेमि ल.९ सेमि चौ.

१ ऊं श्रयो स्तु ॥ सम्वत् ४९९ वैशाष शुक्ल द्वितीया उदय तिथिस श्री यंगलया श्री हरिशन जात्रा दिन शुभ ॥ वैशाष शुक्ल तृतीया उदय

२ तिथिन श्री यंबुया श्री हलशन जात्रा दिन शुभ ॥ थुदिनन शिवकारया दुता श्री श्री जयस्थिति राज मल्ल देव प्रभु स्वामिस आदेसन

३ स्वं देस श्री तव तवमीसन कदाचित लोपन स्थिरारपं चोस्यतो जुरो । कदाचितु थु दिनन मडांयकं लोपालोपनसा श्वम्हस्ता

४ लोपयातसा ब्रम्ह हत्या स्त्री हत्या बाल हत्या थ्वते हत्या पुलाक्व थुदिन स्थिरारपं वुडांयक यंकाले ॥ थ्वते हत्या चुमदो जुरो

५ दुता तव महाभावोस्त प्राप्त जुयु शुभ ॥ परिभाषास ढकुर मारु । सावाथे नाम थडं कृतरपेणो । अमाहला वु छी नाम त

६ व जुको ते कदाचितु थ्वते नेमर पेता मुखश्व याकाले । यातस ख्वाल सोसन साक्षि थादुते यातस छोयार नाम तव परिता

७ ज दम्म१२ थ्व दम्म काये श्री यडंलन वरसा श्री यंबुन काये । श्री यंबुन वरसा यंगलनकाये ॥ धात्थेस वुदेस नायकसन

काल्व विय जुरो ॥ अथ रानी याके थु दाम कार डांन श्री श्री राजकुल यातकुल साक्षि नासन दु आदेस देस व जन विख मदो जुरो ।

९ राजा दैविक जुकाले यत्र डांयके तेवस सामरगीन यंबु तव तवमीसन छोदायेना मदो । एतत् क्षत्रस

एवन धात मया

१० ष तोलकाव थो तव जयराज नामन शुभ । गदेस जुक्व दमोघधरा तसा गुठ गोपति तस्य(त्रीभजोति) एव

११ स श्वडा छाये नाम अत शुभ साक्षि श्री श्री श्री (योगमति) भटारिकास याचन्द्रार्क मेदिनी तावत स्थिरा भवतु शुभमस्तु ॥

भावार्थः

कल्याण होस् । नेपाल संवत् ४९९(वि.सं. १४३५) वैशाष शुक्ल द्वितीयाको उदय तिथिमा श्री यंगलका श्री हरिशनको जात्राको दिन हो शुभ । वैशाख शुक्ल तृतीयाको उदय तिथिमा श्री यंबुका

हरिशनको जात्राको दिन हो शुभ । यी दिनहरुमा श्री श्री जयस्थिति राज मल्ल देव प्रभुस्वामीको आदेशले जो जो दाताहरु हुन् उनीहरुले गरेका कार्य लोप नहोस् भनी स्थिति बन्दोवस्तको काम लेखाएर राख्नेकाम शिवकारलाई दिइयो ।

केही गरि यी दिनहरुमा जात्रा चलाएन भने जो जसले लोपालोप गर्न खोज्छ र गर्छ ती लोप गराउनेहरु लाई ब्रह्म हत्या स्त्री हत्या बाल हत्या जस्ता हत्याको पाप लागोस् । यी दिनहरुमा स्थिति बन्दोवस्त बमोजिम काम चलाउदै गए भने उनीहरुलाई यी हत्याको पाप लाग्ने छैन । आयस्ता दत्त राखिएका जति महाभावोलाई प्राप्त होस् शुभ ।

यो परिभाषामा भनिएका जति गर्नु प यो र जोजसको नाममा काम तोकिएको हो उनीहरुले ती काम गर्नु प यो भनी व्यवस्था गरियो । अमाहलाको खेत रोपनी १ जसको नाममा छ उसले जात्राको दिनमा देवताको मुख स्नान गराउने , भनिए बमोजिम गरे गरेनन् भनी साक्षी राख्नु पर्ने गरियो ।

परिभाषामा जात्राको दिन श्री यंगलमा आउने बेलामा दाम १२ यंबुले लिने, श्री यंबुमा आउने बेला यंगलले लिने । भनिए जति खेतको आयस्ता नायकहरु बीच लेनदेन गरे हुने भयो ।

यसमा रानी संग लिने दाम कामका लागि श्री राजकुल र यात्राकुलहरुको साक्षी राखी आदेश बमोजिम लेनदेन गरिने छ ।

यदि राजाको दैवसंयोगले स्वर्गीय भएमा जात्रा चलाउनेहरुले जात्रा चलाउने सबै सामाग्रीहरु यंबुवासी दाताहरुले राख्न पाउने छैन । यी क्षेत्रहरुमा भनिए लेखिए बमोजिमको काम गरिएन भने तिनीहरुको नाम हटाउने काम जयराजलाई दिइयो । दमोघधरलाई गुठी चलाउने काम दिइयो ।

यसर्थ साक्षीमा योगमती भट्टारिका र चन्द्र सूर्य पृथ्वी रहुञ्जेल साक्षी राखी स्थिति बन्दोवस्तको दीगो कामना गरियो । शुभ कल्याण होस् ।

Synoptic translation of the copper plate inscription of NS. 499

Om Hail ! On the second day of bright fortnight of Baisakh of Nepal Era 499(April/May 1379 AD) this is the royal command of King Jayasthiti Malla not to stop but to keep continued the rituals and the processional festival of Harisana of Yambu that was coming down from history. All the responsible personals should act according to their respective duties.

The acts should be done on the witness of Yogmati Bhattarika and she will be helped by Sivakara and other respective donors.

If not done properly they will be punished after their death according to three heinous crimes of killing wife, children and a Brahmin and if done accordingly will be prized with the happy life in heaven.

INSCRIPTION 03



ID No.: A/K197-INS 03

Size: 14 x 30 cm

Material: Copper plate

Date: NS 543 (1423 A.D)

Script: Bhujinmola

Subject contained: Mentions about the rituals and festivals to keep continued and talks about the ownership of the structure (Kasthamandapa) to three Mahapatras of Patan including Kantipur.

Epigrapher: Shyamsundar Rajvamsi, Chief Epigraphist of Dept of Archaeology.

काष्ठमण्डपको तामापत्र नाप ३०सेमि ल.१४सेमि चौ

१ ऊं शुभ । स्वस्ति श्री श्री श्री पशुपति भट्टारकस्य पाद पंकज धवल बहल कीर्तिःतस्य पाद
पद्मोपजीविनः रघुवंशावता

२ र अंधकार कुम्हजं चार्जेतिः श्री मतः श्री श्री श्री मानेश्वरी वरलब्ध प्रसाद विराजमानः श्री श्री
राघवकुल कमल प्रकाशितः श्री

३ रघुवंसस्तिलकाय मानः समस्त पकृया विराजमानः महामहः॥ महाराजाधिराज प्रमेश्वर प्रम
भटारकः श्री श्री जय जोति म

४ ल देवस्य विजय राजेः तत श्री मानीगलः श्री श्री मनीकुम्हार चरणावुज सेवितः श्री तृभय
महापात्र प्रमुषादिः

५ श्री दक्षिण विहार प्रधान महामहःमहापात्र सहानुगतनः सप्तकुतुंबज महापात्रस शुद्धि समुचयनः
थ्वते श्री

६ श्री राजकुल श्री मनीगलः । तव तवमीस शुद्धि समतसापषनः श्री यहंः श्री यंगलः श्री यंबुः गृह
भंग याच मते

७ यकः जावत चन्द्राक मेदनी वहरप तोतः तावत थिरयाडं लोपालोपिः मद्द्वयकः थ्व निक्षेप पत्र
थिरकालात्र

याडं तव पत्र चोसन तयाजुरोः । तत पत्रकेन कश्चित लोपयित्वा महारौरव नारके प्रतिपतयेतः
कदाचि

९ तः थ्व भाषाः सुना लोपर परद्रोसः । गो हथ्या त्रि हथ्या ब्रम्ह हथ्या निसाषः निरमूल दंज माल्व
जुरो ॥

१० ऊं श्रियो स्तु ॥ सम्वत् ५४३ आषाढ शुक्ल दशम्याया तिथो ॥ स्वाति नक्षत्र सिद्धियोगे ।
शुकवासरे ॥ ॥

११ थ्व संवद्धरन हडंपाया हडां पति षोचमाल्वः मषोडा द्वाकाले अकर्ण जुरोः ॥ शुभ मंगलं भवतु
सर्व जगतः ॥

भावार्थ :

कल्याण होस् । श्री श्री श्री पशुपति भट्टारकको पाउमा आफ्नो कीर्ति र त्यसको चरण कमलमा
जीवन अर्पण गर्ने ,रघुवंशका अवतार भएका ,अंधकारलाई हटाई उज्यालो ल्याउने ,श्री मत् श्री श्री
श्री मानेश्वरीको वर प्रसाद पाएका, श्री श्री श्री राघव कुलमा, कमलासनमा विराजमान भएका,

रघुवंशको तिलक पाएर संपूर्ण मान प्रतिष्ठाले युक्त यसता महामहीम महाराजाधिराज परमेश्वर परम भट्टारक श्री श्री ज्योति मल्ल देवको विजय राज्यमा ।

त्यसैगरि श्री मानीगल एवं श्री श्री मनीकुमारको चरण कमलमा आराधना सेवा गर्ने श्री त्रिभय महापात्रका प्रमुख समेत भएका श्री दक्षिण विहारका प्रधान महामहीम महापात्र सहअनुयायी सप्तकुटुम्बज महापात्रहरुको समेत शुद्ध समुच्चायकत्वमा श्री राजकुल श्री मनीगलमा जो जसले राखेका शुद्ध कीर्ति हुन् त्यसलाई यल(पाटन), यंगल , यम्बु एउटै घर मानी छुट्टाछुट्टै भएर काम नगरियोस् ।

यसमा देखीजान्ने साक्षीमा चन्द्र सूर्य पृथ्वीलाई राखेको छ । जवसम्म चन्द्र सूर्य पृथ्वी रहन्छन् तवसम्म कीर्तिहरु ठीक दुरुस्त राखियोस् । यसलाई लोप गर्ने मास्नेकाम नहोस् भनी यो निक्षेप पत्र तयार गरि कीर्ति स्थीर भएर जाओस् भनी सोको व्यहोरा लेखेर राखियो । पत्रमा लेखिए बमोजिमको काम केही गरि लोप गराउन खोजे भने उ महा रौरव जस्ता नरक भोग गर्न पर्ला भनी सचेत पनि गराइयो । कदाचित् यो भाषामा भनीएको काम कसैले लोप गरे भने गौहत्या, स्त्रीहत्या ब्रह्महत्या जस्ता दोष लाग्ने छ अतः पाप भावनालाई निर्मूल पार्नु पर्छ ।

कल्याण होस् । नेपाल संवत् ५४३(वि.सं १४७९) आषाढ शुक्ल दशमी तिथि स्वाति नक्षत्र सिद्धियोग शुक्रवारको दिन। यस संवत्सरमा अघि देखि चलदै आएको चलनलाई अखण्डरूपले कायम राख्नु पर्यो । यदि अखण्ड रूपले कायम भएन भने त्यो अकर्णा(विचलन) भएको हुनेछ । सबै मंगलै मंगल होस् सबै जगत को भलो होस् ।

Synoptic translation of the copperplate inscription of NS. 543

Hail ! On 10th. of bright fortnight of Asadh of NS 543 (June/July 1412 AD) This is the command of the King Joytirmalla not to stop all the rituals and festivals that was being observed since long time in Patan and Kantipur but should be kept continued. This is the royal command that is promulgated by King Jyotirmalla and if not observed at prescribed those responsible will accrue the punishment. If kept continued everybody in the society will accrue merit.

Let all be prosperous.



ID No.: A/K197-PNL 1 to 4

Name: Frieze carved with religious story.

Monument: Kasthamandap

Size: a) Length: 5.5 m in total in 4 pieces.

b) Height: 7 cm

c) Thickness: 3 cm.

Quantity: 4

Material: Wood.

Currently stored at: Office store inside Mul Chowk.

Remarks & Recommendations: More parts of bottom are broken off. The figures have weathered but still recognizable to some extent. Needs to be cleaned chemically and put in the museum. To be replaced with new carved one, in the structure if it be necessary.

ID No.: A/K197-ICON(W) 01

Name: Bhairava

Monument: Kasthamandap (Ground Floor Balustrade)

Size: 44 X 24 X 10 cm

Quantity: 1

Material: Wood

Currently stored at: Shelter 1

Remarks & Recommendation: Three upper hands in left side seem slightly damaged. A bit of the 1st petal on the left side has been scrapped off. Give a wash and reuse it.



ID No.: A/K197-ICON(W) 02

Name: Bhairava

Monument: Kasthamandap (Ground Floor
Balustrade)

Size: 44 X 25 X 10 cm

Quantity: 1

Material: Wood

Currently stored at: Shelter 1

Remarks & Recommendation: Second lotus
petal (from the right) has been slightly scrapped
off. Cracks are developed on the dragon's right
hand between second and third finger. Give wash
and reuse it.



ID No.: A/K197-ICON(W) 03

Name: Bhairava

Monument: Kasthamandap (Ground Floor
Balustrade)

Size: 44 X 24 X 10 cm

Quantity: 1

Material: Wood

Currently stored at: Shelter 1

Remarks & Recommendation: Face and first hoof of the bull has been totally scraped off. Parts of first lotus (from the left) and an attribute being held in the left hand have been slightly chipped off. The right hand side of the top lotus and the torso of the left dragon have been slightly scraped off. Give a wash and reuse it.



ID No.: A/K197-ICON(W) 04

Name: Bhairava

Monument: Kasthamandap (Ground Floor
Balustrade)

Size: 45 X 25 X 10 cm

Quantity: 1

Material: Wood

Currently stored at: Shelter 1

Remarks & Recommendation: Small scrapes can be seen on the left foot, second right hands, first left hand, eyebrows of the dragon and top lotus. Small cracks divide the 3rd and 4th (from the right) petals of the bottom lotus. Give a wash and use it.



ID No.: A/K197-ICON(W) 05

Name: Bhairava

Monument: Kasthamandap (Ground Floor
Balustrade)

Size: 44 X 25 X 10 cm

Quantity: 1

Material: Wood

Currently stored at: Shelter 1

Remarks & Recommendation: Few scrapes can be seen on the left foot, left attributes, nozzle of the dragon and the right of the wing. The facial features of the idol has been rubbed off due time. Give a wash and reuse it.



ID No.: A/K197-ICON(W) 06

Name: Bhairava

Monument: Kasthamandap (Ground Floor
Balustrade)

Size: 44 X 26 X 10 cm

Quantity: 1

Material: Wood

Currently stored at: Shelter 1

Remarks & Recommendation: Long cut that draws from the face of the dragon and divides the right hands from the main body of the idol. The right leg and bull has also been chipped off. A crack also divides the 2nd and 3rd (from the left) petal of the bottom lotus. The features of pillar has also been rubbed off due time. Give a wash and reuse it.



ID No.: A/K197-ICON(W) 07

Name: Bhairava

Monument: Kasthamandap (Ground Floor
Balustrade)

Size: 44 X 26 X 10 cm

Quantity: 1

Material: Wood

Currently stored at: Shelter 1

Remarks & Recommendation: Cracks run through left side of dragon's face, side of the idol's head and some cracks can be seen on the garments of idol on the right side. Small cut can also be seen on the 3rd petal (from the right) of the bottom lotus. Give the wash and reuse it.



ID No.: A/K197-ICON(W) 08

Name: Bhairava

Monument: Kasthamandap (Ground Floor
Balustrade)

Size: 44.5 X 25 X 10 cm

Quantity: 1

Material: Wood

Currently stored at: Shelter 1

Remarks & Recommendation: In intact condition.

Give a wash and reuse it.



ID No.: A/K197-ICON(W) 09

Name: Bhairava

Monument: Kasthamandap (Ground Floor
Balustrade)

Size: 45 X 26 X 11 cm

Quantity: 1

Material: Wood

Currently stored at: Shelter 1

Remarks & Recommendation: slight scrapes can be seen on right pillar, right hands, right dragon, the bull, the garland and the eyes and wings of the dragon. Just give a wash and reuse it.



ID No.: A/K197-ICON(W) 10

Name: Bhairava

Monument: Kasthamandap (Ground Floor
Balustrade)

Size: 45 X 26 X 10 cm

Quantity: 1

Material: Wood

Currently stored at: Shelter 1

Remarks & Recommendation: Slight crack on the
left dragon can be seen. Slight scrape on the left
hand of the idol. Give a wash and reuse it.



ID No.: A/K197-ICON(W) 11

Name: Bhairava

Monument: Kasthamandap (Ground Floor
Balustrade)

Size: 43 X 25 X 10 cm

Quantity: 1

Material: Wood

Currently stored at: Shelter 1

Remarks & Recommendation: Small part of the 4th right hand and attribute held by it has been scraped off. The attribute being held on the 3rd left hand has been slightly scraped off. Major part of left dragon and small part of left snake has been chipped off. The 1st petal on the right side and right dragon has also been slightly scraped. Fix the missing parts though partially.



ID No.: A/K197-ICON(W) 12

Name: Eight handed Bhairava

Monument: Kasthamandap (Ground Floor Balustrade)

Size: 44 X 25 X 11 cm.

Quantity: 1

Material: Wood

Currently stored at: Shelter 1

Remarks & Recommendation: Still intact but left hand attributes are scratched. One cleaning is enough.



ID No.: A/K197-ICON(W) 13

Name: Bhairava

Monument: Kasthamandap (Ground Floor
Balustrade)

Size: 44 X 25 X 11 cm

Quantity: 1

Material: Wood

Currently stored at: Shelter 1

Remarks & Recommendation: First right side petal
of bottom lotus has been slightly chipped off and
there is slight scratch of the left pillar. Give a wash
and reuse it.



ID No.: A/K197-ICON(W) 14

Name: Bhairava

Monument: Kasthamandap (Ground Floor
Balustrade)

Size: 44 X 25 X 11 cm

Quantity: 1

Material: Wood

Currently stored at: Shelter 1

Remarks & Recommendation: The right dragon, the
attributes on the 1st and 2nd left hand of the idol and
the left side of the garland have been chipped off.

There is a cut that stretches from the head idol down
to the bull and divides the 2nd and 3rd (from the left) petal of the bottom lotus.
Some scrapes can also be seen on the head of the idol. The 1st petal from the
right of the bottom lotus has also been slightly scraped. Re-carve the missing
part and refit.



ID No.: A/K197-ICON(W) 15

Name: Bhairava

Monument: Kasthamandap (Ground Floor Balustrade)

Size: 44 X 26 X 10 cm

Quantity: 1

Material: Wood

Currently stored at: Shelter 1

Remarks & Recommendation: A cut can be seen dividing the 4th petal (from the bottom lotus).

There is a crack on the torso of the idol and also one that separates the left hand from the body.

Give a wash and reuse it.



ID No.: A/K197-ICON(W) 16

Name: Bhairava

Monument: Kasthamandap (Ground Floor Balustrade)

Size: 44.5 X 25 X 11 cm

Quantity: 1

Material: Wood

Currently stored at: Shelter 1

Remarks & Recommendation: Features of the face of the idol, left pillar, face of the dragon and the left dragon has been rubbed off over time. It is old. This is one of the original and the oldest Bhairava ICON(W) found in Kasthamandap, carved in deep relief. Give wash and reuse it in important place, preferably in the entrance side.



ID No.: A/K197-ICON(W) 17

Name: Bhairava

Monument: Kasthamandap (Ground Floor
Balustrade)

Size: 46 X 25 X 11 cm

Quantity: 1

Material: Wood

Currently stored at: Shelter 1

Remarks & Recommendation: Long crack divides
the dragon's left wing, the snake on the left side
and the attribute held on the right hand. Give
wash and reuse it.



ID No.: A/K197-ICON(W) 18

Name: Bhairava

Monument: Kasthamandap (Ground Floor
Balustrade)

Size: 45 X 26 X 11cm

Quantity: 1

Material: Wood

Currently stored at: Shelter 1

Remarks & Recommendation: The head of the right
dragon has been slightly scraped off. The first petal
from the right of the bottom Lotus has also been
slightly scraped. Give wash and reuse it.



ID No.: A/K197-ICON(W) 19

Name: Bhairava

Monument: Kasthamandap (Ground Floor Balustrade)

Size: 44 X 26 X 10cm

Quantity: 1

Material: Wood

Currently stored at: Shelter 1

Remarks & Recommendation: There is a slight crack on the right side of the face of the dragon. A deep crack divides the attribute on the left hand which runs through the left foot and cuts between second and third (from the right) petals of the bottom Lotus. Tighten the cracked by knot bolt then wash and reuse it.



ID No.: A/K197-ICON(W) 20

Name: Bhairava.

Monument: Kasthamandap (Ground Floor
Balustrade)

Size: 44 X 24 X 10cm

Quantity: 1

Material: Wood

Currently stored at: Shelter 1

Remarks & Recommendation: The right side of the whole sculpture has been scraped off including the right dragon, right pillar and the first petal (from the right) of the bottom Lotus. Slight scrapes can also be seen of the attribute held on the right and on the Lotus where the left foot is rested upon. Mend it with the scrapped part and wash then reuse it.



ID No.: A/K197-ICON(W) 21

Name: Bhairava.

Monument: Kasthamandap (Ground Floor
Balustrade)

Size: 44 X 24 X 10cm.

Quantity: 1

Material: Wood

Currently stored at: Shelter 1

Remarks & Recommendation: Still intact. Give wash
and reuse it.



ID No.: A/K197-ICON(W) 22

Name: Bhairava.

Monument: Kasthamandap (Ground Floor
Balustrade)

Size: 44 X 25 X 10cm.

Quantity: 1

Material: Wood

Currently stored at: Shelter 1

Remarks & Recommendation: Slight scrapes can be seen on the left wing of the dragon the garland of the idol and on the eyes of the dragon. Give wash and reuse it



ID No.: A/K197-ICON(W) 23

Name: Bhairava

Monument: Kasthamandap (Ground Floor
Balustrade)

Size: 44 X 25 X 11cm

Quantity: 1

Material: Wood

Currently stored at: Shelter 1

Remarks & Recommendation: The right dragon
and the face of the bull have been completely
chipped off. Few scrapes can be spotted on the top
of the dragon's left wing, 3rd and 4th left hand, 4th
right hand, left pillar, right foot and first and sixth
petal (from the right) of the bottom Lotus. Give wash and reuse it.



ID No.: A/K197-ICON(W) 24

Name: Bhairava

Monument: Kasthamandap (Ground Floor
Balustrade)

Size: 44 X 25 X 10 cm

Quantity: 1

Material: Wood

Currently stored at: Shelter 1

Remarks & Recommendation: Still intact Give
wash and reuse it.



ID No.: A/K197-ICON(W) 25

Name: Bhairava

Monument: Kasthamandap (Ground Floor
Balustrade)

Size: 45 X 25 X 10 cm.

Quantity: 1

Material: Wood

Currently stored at: Shelter 1

Remarks & Recommendation: Still intact Give a
wash and reuse it.



ID No.: A/K197-ICON(W) 26

Name: Bhairava

Monument: Kasthamandap (Ground Floor
Balustrade)

Size: 45 X 25 X 10 cm.

Quantity: 1

Material: Wood

Currently stored at: Shelter 1

Remarks & Recommendation: Slight scrapes can be
seen on the second, third and fourth right hands of
the idol. Give wash and reuse it.



ID No.: A/K197-ICON(W) 27

Name: Bhairava

Monument: Kasthamandap (Ground Floor
Balustrade)

Size: 45 X 23 X 9 cm

Quantity: 1

Material: Wood

Currently stored at: Shelter 1

Remarks & Recommendation : Few parts of the 1st
and 2nd left hand, 2nd right hand of the idol, right
pillar, tip of the sculpture as well as the 1st petal
(from the left) of bottom Lotus have been slightly
chipped off. Few slight scrapes can be seen on the
tip at the right wing of the dragon and the top Lotus. Give wash and reuse it.



ID No.: A/K197-ICON(W) 28

Name: Bhairava

Monument: Kasthamandap (Ground Floor Balustrade)

Qty: 1

Size: 43 X 25 X 11cm

Quantity: 1

Material: Wood

Currently stored at: Shelter 1

Remarks & Recommendation: Most of the features of the whole sculpture have been rubbed off over time. The idol is missing the 4th hand and the attribute being held by it. A small cut can be seen on the middle petal of the bottom Lotus. This is one of the original Bhairav image. Could be refitted when re-erection starts. However a wash is to be given.



ID No.: A/K197-ICON(W) 29

Name: 12 handed Bhairav

Monument: Kasthamandap (Ground Floor
Balustrade)

Size: 39 X 24 X 10 cm

Quantity: 1

Material: Wood

Currently stored at: Shelter 1

Remarks & Recommendations: Face of Cheep
is scrapped off. Most eroded and all attributes
gone. Give a wash and reuse.



ID No.: A/K197-ICON(W) 30

Name: 2 Handed Bhairav.

Monument: Kasthamandap (Ground Floor
Balustrade)

Size: 44 X 24 X 9 cm.

Quantity: 1

Material: Wood

Currently stored at: Shelter 1

Remarks & Recommendations: In totality, still
good. A wash is to be given. Rest is okay.



ID No.: A/K197-ICON(W) 31

Name: 8 Handed Bhairav.

Monument: Kasthamandap (Ground Floor
Balustrade)

Size: 44 X 24 X 10 cm.

Quantity: 1

Material: Wood

Currently stored at: Shelter 1

Remarks & Recommendations: Left leg and
half face are gone. Rest is Okay. Give a wash,
enough then reuse.



ID No.: A/K197-ICON(W) 32

Name: 2 Handed Bhairav.

Monument: Kasthamandap (Ground Floor
Balustrade)

Size: 44 X 24 X 10 cm

Quantity: 1

Material: Wood

Currently stored at: Shelter 1

Remarks & Recommendations: Khadga of main
attribute is gone. Rest is ok. Give a wash and
reuse then.



ID No.: A/K197-ICON(W) 33

Name: 2 Handed Bhairava. (Hands are gone.)

Monument: Kasthamandap (Ground Floor
Balustrade)

Size: 44 X 25 X 11 cm.

Quantity: 1

Material: Wood

Currently stored at: Shelter 1

Remarks & Recommendations: Lower portion is found cut out to fix balustrade. Right one *makar* is also flaked off. It seems this is one of the oldest one. This is the first generation of Bhairav ICON(W) used in Kasthamandap. The carving is more pronounced. The intricacy of carving is more pronounced. Give the wash and reuse though mutilated.



ID No.: A/K197-ICON(W) 34

Name: 8 handed Bhairava.

Monument: Kasthamandap (Ground Floor
Balustrade)

Size: 43 X 24 X 11 cm

Quantity: 1

Material: Wood

Currently stored at: Shelter 1

Remarks & Recommendations: Still intact
though dirt covered. Give a wash and reuse.



ID No.: A/K197-ICON(W) 35

Name: 8 Handed Bhairava.

Monument: Kasthamandap (Ground Floor
Balustrade)

Size: 45 X 24 X 9 cm

Quantity: 1

Material: Wood

Currently stored at: Shelter 1

Remarks & Recommendations: Still intact.

Give a wash and reuse.



ID No.: A/K197-ICON(W) 36

Name: 8 Handed Bhairava.

Monument: Kasthamandap (Ground Floor
Balustrade)

Size: 43 X 24 X 10 cm

Quantity: 1

Material: Wood

Currently stored at: Shelter 1

Remarks & Recommendations: Still intact.

Give a wash and reuse.



ID No.: A/K197-ICON(W) 37

Name: 2 Handed Bhairava.

Monument: Kasthamandap (Ground Floor
Balustrade)

Size: 45 X 25 X 9 cm

Quantity: 1

Material: Wood

Currently stored at: Shelter 1

Remarks & Recommendations: Right leg is
broken, rest is intact. Refix the broken leg,
give wash and reuse.



ID No.: A/K197-ICON(W) 0038

Name: Bhairava

Monument: Kasthamandap (Ground Floor
Balustrade)

Size: 44 X 25 X 10 cm

Quantity: 1

Material: Wood

Currently stored at: Shelter 1

Remarks & Recommendation: Still intact. Give a
wash and reuse. Still attached to balustrade.



ID No.: A/K197-ICON(W) 0039

Name: 8 Handed Bhairava

Monument: Kasthamandap (Ground Floor
Balustrade)

Size: 43 X 24 X 9 cm

Quantity: 1

Material: Wood

Currently stored at: Shelter 1

Remarks & Recommendation: Still intact. Give a
wash and reuse. Still attached to balustrade.



ID No.: A/K197-ICON(W) 40

Name: 8 Handed Bhairava.

Monument: Kasthamandap (Ground Floor
Balustrade)

Size: 43 X 25 X 10 cm

Quantity: 1

Material: Wood

Currently stored at: Shelter 1

Remarks & Recommendation: Still intact. Give a
wash and reuse. Still attached to balustrade.



ID No.: A/K197-ICON(W) 41

Name: 8 Handed Bhairava.

Monument: Kasthamandap (Ground Floor
Balustrade)

Size: 44 X 25 X 11 cm

Quantity: 1

Material: Wood

Currently stored at: Shelter 1

Remarks & Recommendation: Still intact. Give a
wash and reuse, still attached to balustrade.



ID No.: A/K197-ICON(W) 42

Name: 2 Handed Bhairava.

Monument: Kasthamandap (Ground Floor
Balustrade)

Size: 43 X 25 X 10 cm

Quantity: 1

Material: Wood

Currently stored at: Shelter 1

Remarks & Recommendation: Still intact. Still
attached to balustrade. Give a wash and reuse it.



ID No.: A/K197-ICON(W) 43

Name: 8 Handed Bhairava.

Monument: Kasthamandap (Ground Floor
Balustrade)

Size: 44 X 26 X 10 cm

Quantity: 1

Material: Wood

Currently stored at: Shelter 1

Remarks & Recommendation: Still intact. Still
attached to balustrade. Give a wash and reuse it.



ID No.: A/K197-ICON(W) 44

Name: 8 Handed Bhairava.

Monument: Kasthamandap (Ground Floor
Balustrade)

Size: 44 X 25 X 9 cm

Quantity: 1

Material: Wood

Currently stored at: Shelter 1

Remarks & Recommendation: Attributes in
left hands are flaked off. Rest is still intact.
Give a wash and reuse it again. Flaking is
negligible.



ID No.: A/K197-ICON(W) 45

Name: 2 Handed Bhairava.

Monument: Kasthamandap (Ground Floor
Balustrade)

Size: 44 X 25 X 11 cm

Quantity: 1

Material: Wood

Currently stored at: Shelter 1

Remarks & Recommendation: Still intact. Give a
wash and reuse.



ID No.: A/K197-ICON(W) 46

Name: 8 Handed Bhairava.

Monument: Kasthamandap (Ground Floor
Balustrade)

Size: 42 X 23 X 11 cm

Quantity: 1

Material: Wood

Currently stored at: Shelter 1

Remarks & Recommendation: Chhepu on top and
Head of the Nandi is flaked off. Rest is almost
intact. Replace Chhepu and bull's head then give
wash and reuse.



ID No.: A/K197-ICON(W) 47

Name: 8 Handed Bhairava.

Monument: Kasthamandap (Ground Floor Balustrade)

Size: 42 X 16 X 10 cm (Existing)

Quantity: 1

Material: Wood

Currently stored at: Shelter 1

Remarks & Recommendation: Right half of the ICON(W) is broken off and lost. Make a new and replace it. Old one, send it to the Museum.



ID No.: A/K197-ICON(W) 48

Name: 8 Handed Bhairava.

Monument: Kasthamandap (Ground Floor Balustrade)

Size: 41 X 12 X 10 cm (Existing)

Quantity: 1

Material: Wood

Currently stored at: Shelter 1

Remarks & Recommendation: Left half is broken off and lost. Remaining portion is also beyond recognition. Replace it with new one.



ID No. : A/K197-Pillar 1

Name: Tham (Pillar) – Ground storey

Monument: Kasthamandap

Size: 475 X 38 X 38 cm

Quantity: 3 recoverd (originally 4)

Material: Wood

Currently stored at: Two are at the base of Big Bell outside the Durbar Premise.
One is in Nhulachhen Chowk.

Remarks & Recommendation: Re-strengthen the pillar by fitting new tenons
and reuse it.



ID No. : A/K197-Pillar 2

Name: Tham (Pillar) – upper storey

Monument: Kasthamandap

Size: 200 X 18 X 18 cm

Quantity: 30

Material: Wood

Currently stored at: Shelter 2

Remarks & Recommendation: Re-strengthen the pillar by fitting new tenons and reuse it.



ID No. : A/K197-Meth 1

Name: Meth (Big)

Monument: Kasthamandap

Size: 113 X 30 X 34 cm

Quantity: 16

Material: Wood

Currently stored at: Shelter 1 & Shelter 2

Remarks & Recommendation: Can be reused after a wash



ID No. : A/K197-Meth 1

Name: Meth (Small) – Full and half

Monument: Kasthamandap

Size: Max. 125 X 24 X 24cm to Min. 58 X 13 X10cm

Quantity: 135+

Material: Wood

Currently stored at: Shelter 1 & Shelter 2

Remarks & Recommendation: Can be reused after a wash.



ID No. : A/K197-Miscellaneous

Name: Decorative Piece (Middle Storey)

Monument: Kasthamandap

Size: 48 X 23 cm

Quantity: 2 (Surya and Chandra)

Material: Wood

Currently stored at: Shelter 1

Remarks & Recommendation: Can be reused after a wash.



ID No. : A/K197-ICON(S) 01

Name: Stone Image of Gorakhnath

Monument: Kasthamandap

Size: 35 X 60 cm

Quantity: 1

Material: Stone

Currently stored at: Nhulachhen Chowk

Remarks & Recommendation: Broken into two pieces. Remake new one and send it to the museum because the broken icon(S) are not traditionally worshipped. Lower piece lost but latter found in National Museum. Will be refitted.



ID No. : A/K197-ICON(S) 02

Name: Stone Image of Ashok Vinayaka

Monument: Kasthamandap

Size: 70 X 65 cm

Quantity: 1

Material: Stone

Currently stored at: Nhulachhen Chowk

Remarks & Recommendation: Reestablish in situ after the renovation of the structure is done.



ID No. : A/K197-ICON(S) 03

Name: Stone Image of Jala Vinayaka

Monument: Kasthamandap

Size: 60 X 80 cm

Quantity: 1

Material: Stone

Currently stored at: Nhulachhen Chowk

Remarks & Recommendation: Right palm is broken off. Rest is good.



ID No. : A/K197-ICON(S) 04

Name: Stone Image of Karya Vinayaka.

Monument: Kasthamandap

Size: 60 X 75 cm

Quantity: 1

Material: Stone

Currently stored at: Nhulachhen Chowk

Remarks & Recommendation: Re-establish in situ
after the renovation work is done.



ID No. : A/K197-ICON(S) 05

Name: Stone Image of Surya Vinayaka

Monument: Kasthamandap

Size: 60 X 75 cm

Quantity: 1

Currently stored at: Nhulachhen Chowk

Material: Stone.

Remarks & Recommendations: Right palm
broken and lost. Reestablish in situ after the
renovation of the structure is done.



NAU DEGA (BIMALESVARA TEMPLE) (B/K-196)

01. Struts

02. Kunsala

03. Windows

04. Doors

05. Pillar

06. Meth

07. Chakulaan

08. Dhalinkhwa

ID No.: B/K 196-TDL 01

Name: Tripurantak Bhairav

Monument: Nau Dega (Bimalesvara Temple)

Size. : 107 X 13 X 10 cm

Quantity: 1

Material: Wood.

Currently stored at: Shelter-2

Remarks & Recommendations. : Except four hands broken off rest is in excellent condition. The strut could be reused perfectly. The pedestal portion has the figure of a mendicant.



ID No.: B/K 196-TDL 02

Name: Six armed Bhairav.

Monument: Nau Dega (Bimalesvara Temple)

Size: 110 X 16.X11 cm

Quantity: 1

Material: Wood.

Currently stored at: Shelter-2

Remarks & Recommendations: Except top portion little broken off rest is still good. The hands of the main Bhairav figure and a hermit-like figure in pedestal part is flaked off during earthquake. The condition of wood is still good and can be reused. Giving little wash and adding lost hands can bring the reuse of the strut. The timber condition is still good enough from inside.



ID No.: B/K 196-TDL 03

Name: Ugra aspect of Kroddha Bhairav

Monument: Bimalasvara.

Size: 108.5 X 17.5 X 10.5 cm

Quantity: 1

Material: Wood.

Currently stored at: Shelter-2

Remarks & Recommendations: The condition is good enough. A soda water wash is recommended before reuse.



ID No.: B/K 196-TDL 04

Name: A form of Unmatta Bhairav

Monument: Nau Dega (Bimalesvara Temple)

Size: 104.5 X 16 X 9 cm

Quantity: 1

Material: Wood.

Currently stored at: Shelter-2

Remarks & Recommendations: Still intact. Pedestal portion has a figure of Vidyadhara. A soda water is recommended to reuse.



ID No.: B/K 196-TDL 05

Name: Asintanga Bhairava

Monument: Nau Dega (Bimalessvara Temple)

Size: 110 X 16 X 10 cm

Quantity: 1

Material: Wood.

Currently stored at: Shelter-2

Remarks & Recommendations: Still in good condition.

Can be reused after slight soda water wash is recommended.



ID No.: B/K 196-TDL 06

Name: Bhairav with bindu mudra and kapala.

Monument: Nau Dega (Bimalessvara Temple)

Size. : 108.5 X (14.5+9) X 9 cm.

Quantity. : 1

Material: Wood.

Currently stored at: Shelter-2

Remarks & Recommendations: Right portion on top is flaked off. Can still be reused giving the top recarved that is lost.



ID No.: B/K 196-TDL 07

Name. : Bhisana Bhairav

Monument: Nau Dega (Bimalesvara Temple)

Size: 115 X 16 X 9 cm

Quantity: 1

Material: Wood.

Currently stored at: Shelter-2

Remarks & Recommendations: Good. Four hands are to be replaced. Four still remains. Providing lost hands in right side that totals to 5. The Yogic figure with exposed penis is remarkable of this strut. He must be one among 84 Siddhas. His body is emaciated. This is one of the rarest depictions found in Kathmandu struts. Can be reused with soda water wash.



ID No.: B/K 196-TDL 08

Name: Bhairav with bindu mudra and kapala

Monument: Nau Dega (Bimaesvara Temple)

Size: 116 X 15 X 10 cm

Quantity: 1

Material: Wood.

Currently stored at: Shelter-2

Remarks & Recommendations: Only two major hands are left, six are gone off. The condition of the timber is good enough but the upper right portion with one line of flowers are broken off due to earthquake. The emaciated body of a Siddha in pedestal portion is remarkable. A soda water wash is recommended.



ID No.: B/K 196-TDL 09

Name: Muti headed Bhairav with Abaya and Barad mudra

Monument: Nau Dega (Bimalesvara Temple)

Size: 107 X 16 X 9 cm.

Quantity: 1

Material: Wood.

Currently stored at: Shelter-2

Remarks & Recommendations: Out of eight hands only two major and one subsidiary hands are left. The wood condition is still good. A yogi perhaps one among 84 Siddha is carved in the pedestal. The main figure is standing on fire. Only cleansing is enough



ID No.: B/K 196-TDL 10

Name: Bhairav with bindu mudra and kapala

Monument: Nau Dega (Bimaesvara Temple)

Size: 108 X 14.5 X 9.5 cm

Quantity: 1

Material: Wood.

Currently stored at: Shelter-2

Remarks & Recommendations: Two hands are gone off and two major ones are still intact. The figure on which the main figure tramples is broken off leaving only belly one leg and one hand below that. The rightmost row of the flower is gone off on top and also the riding vehicle of Bhairav is flaked off in head part and the right leg. The mending of the Betala is necessary. A simple soda water is enough.



ID No.: B/K 196-TDL 11

Name: Bhairav with bindu mudra and kapala

Monument: Nau Dega (Bimalesvara Temple)

Size. : 104 X 14 X 9.5 cm

Quantity: 1

Material: Wood.

Currently stored at: Shelter-2

Remarks & Recommendations: Except few breaks and flaking off rest is intact. A small piece on top is broken off and rest is intact. Could be reused with slight cleaning, the condition of wood is excellent.



ID No.: B/K 196-TDL 12

Name: Ruru Bhairav

Monument: Nau Dega (Bimalesvara Temple)

Size: 108 X 15 X 10 cm.

Quantity: 1

Material: Wood.

Currently stored at: Shelter-2

Remarks & Recommendations: The condition is still intact. Could be reused with cleaning. Slight cleansing is recommended with three hands added.



ID No.: B/K 196-TDL 13

Name: Bhakta Nayak Bhairava.

Monument: Nau Dega (Bimalesvara Temple)

Size: 102 X 10 X 15 cm

Quantity. : 1

Material: Wood.

Currently stored at: Shelter-2

Remarks & Recommendations: Except broken off hands the timber condition is quite good. The condition is good enough for reuse.



ID No.: B/K 196-TDL 14

Name: Krodha Danstra (A form of Ruru Bhairav)

Monument: Nau Dega (Bimalesvara Temple)

Size: 102 X 10 X 18 cm

Quantity: 1

Material: Wood.

Currently stored at: Shelter-2

Remarks & Recommendations: Only one hand remains.
All are gone. The condition of the strut is still good
enough to reuse. The condition is good enough and could
be used after a soda water wash.



ID No.: B/K 196-TDL 15

Name: Bhairav with bindu mudra and kapala.

Monument: Nau Dega (Bimaesvara Temple)

Size: 107 X 15 X 9 cm

Quantity: 1

Material: Wood.

Currently stored at: Shelter-2

Remarks & Recommendations: Only two of six hands are remaining. Four are broken off. Right raised hand of Kubera is flaked off during earthquake. On the pedestal part the figure of Kubera is carved. Could be reused after a soda water wash.



ID No.: B/K 196-TDL 16

Name: Smatika form of Batuk Bhairav

Monument: Nau Dega (Bimalessvara Temple)

Size: (100+9) X 16 X 10 cm

Quantity: 1

Material: Wood.

Currently stored at: Shelter-2

Remarks & Recommendations: Middle portion, due to the water percolation is rotten but still reusable by giving supports on both sides. Only the figure of Betala and the right leg of Bhairava are rotten due to the water percolation. However both the legs of the Bhairava are useless. The pedestal portion has an unusually seated Buddha figure. The left palm and face of Buddha is gone off. The strength of the timber is still good inside. A chemical wash is recommended.



ID No. : B/K 196-TDL 17

Name: One of eight Astamatrikas

Monument: Nau Dega (Bimaesvara Temple)

Size: 150.5 X 21 X 14 cm

Quantity: 1

Material: Wood.

Currently stored at: Shelter-2

Remarks & Recommendations: Two hands of the divine figure are gone off. In totality the condition of strut is good. An insecticide wash is recommended. The figure stands on a lotus flanked by two figures of gnomes. Below them a yogic figure is carved that is the figure of a Siddha encircled by six fishes. He is among 84 Siddhas of Mahayan Buddhism.



ID No.: B/K 196-TDL 18

Name: One of eight Astamatrikas

Monument: Nau Dega (Bimalessvara Temple)

Size: 149 X 21 X 13 cm

Quantity: 1

Material: Wood.

Currently stored at: Shelter-2

Remarks & Recommendations: In totality the condition is good. The condition of the strut is good. Soda water wash is recommended.



ID No.: B/K 196-TDL 19

Name: One of eight Astamatrikas

Monument: Nau Dega (Bimalesvara Temple)

Size: 148 X 23cm X 14 cm.

Quantity: 1

Material: Wood.

Currently stored at: Shelter-2

Remarks & Recommendations: All four hands are gone. Except broken off nose of the Goddess, rest is still strong enough except some climatic erosion. The condition of wood is still strong enough. The base is decorated with a figure of a Siddha swallowing intestine of the fish. A soda water wash is recommended



ID No.: B/K 196-TDL 20

Name: One of eight Astamatrikas. Four armed Female
Goddess standing on a lotus carried by two caryatids (?).

Monument: Nau Dega (Bimalesvara Temple)

Size: (147+2) X 20 X 13 cm

Quantity: 1

Material: Wood.

Currently stored at: Shelter-2

Remarks & Recommendations: All hands are gone.
Relatively in good condition. But piece of nose few flowers
on top and right hand of Ghantapa is hacked off due to earth
quake collapse. The figure of a Siddha (Ghantapa) is carved
in pedestal... A soda wash is enough for reuse.



ID No.: B/K 196-TDL 21

Name: One of eight Astamatrikas

Monument: Nau Dega (Bimalesvara Temple)

Size: 150 X 21X 13 cm.

Quantity: 1

Material: Wood.

Currently stored at: Shelter-2

Remarks & Recommendations: Only hands are gone off.
Other condition is still good enough. Can be reused by
fixing lost hands and soda water wash.



ID No.: B/K 196-TDL 22

Name: One of eight Astamatrikas

Monument. : Nau Dega (Bimalesvara Temple)

Size: 150 X 22.X 13 cm

Quantity: 1

Material: Wooden.

Currently stored at: Shelter-2

Remarks & Recommendations: The flickering part of the dress and six hands are broken off. Rest is still in good condition. Half of the face of Siddha is broken off. A soda water wash is Recommendations before use



ID No.: B/K 196-TDL 23

Name: One of eight Astamatrikas

Monument: Nau Dega (Bimalesvara Temple)

Size: 150 X 22 X 14 cm

Quantity: 1

Material: Wood.

Currently stored at: Shelter-2

Remarks & Recommendations: Two hands are gone also heads of the figures are also broken off. Siddha Kukuripa is carved on the pedestal portion. The condition of wood is still excellent could be reused. Give a wash.



ID No.: B/K 196-TDL 24

Name: One of eight Astamatrikas

Monument: Nau Dega (Bimalesvara Temple)

Size: 147 X 20.5 X 14.5 cm

Quantity: 1

Material: Wood.

Currently stored at: Shelter-2

Remarks & Recommendations: Cracked vertically at the middle. A figure of a Siddha with bow (?) is depicted in the pedestal and colored black. A soda wash is enough for cleaning.



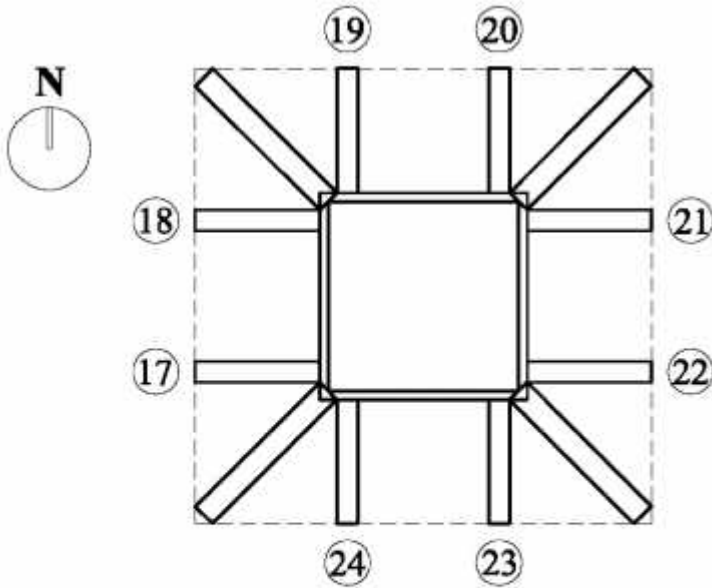

- 1 Tripurantak Bhairava
- 2 Bhairava
- 3 Ugra aspect of Kroddha Bhairava
- 4 A form of Unmatta Bhairava
- 5 Asitanga Bhairava
- 6 Bhairava with bindu mudra and kapaala
- 7 Visana Bhairava
- 8 Bhairava with bindu mudra and kapaala
- 9 Multi headed Bhairava with abhaya and barad mudra
- 10 Bhairava with bindu mudra and kapaala
- 11 Bhairava with bindu mudra and kapaala
- 12 Ruru Bhairava
- 13 Bhakta Nayak Bhairava
- 14 Ruru Bhairava
- 15 Bhairava with bindu mudra and kapaala
- 16 Samantaka form of Bhairava
- 17-24 The eight mother goddesses (Asta Matrikas)

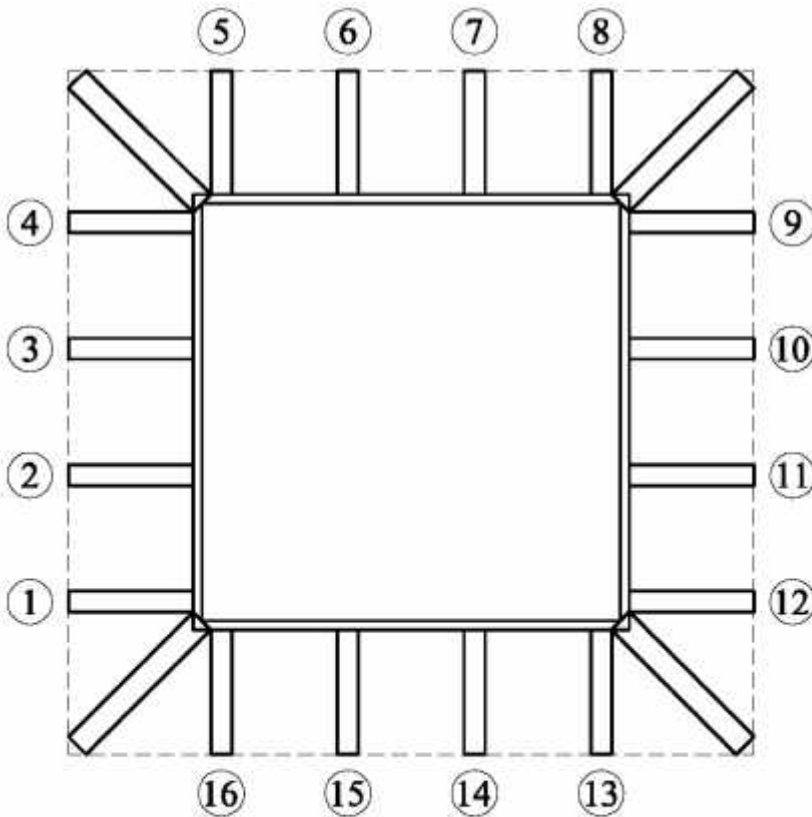

**NAU DEGA: (BIMALESVARA TEMPLE)
(Strut Plan)**

ID No.: B/K 196-K 01

Name: Kunsala (Corner Strut)

Monument: Nau Dega (Bimalessvara
Temple)

Size: H- 113cm (9 X16) cm.

Quantity: 1

Material: Wood

Currently stored at: Shelter-2

Remarks & Recommendation: The
condition of the timber is excellent. This
is one of the best preserved struts. The
condition of the strut is still excellent and
can be reused directly.



ID No.: B/K 196-K 02

Name: Kunsala (Corner Strut)

Monument: Nau Dega (Bimalesvara
Temple)

Size: 117 X 10X 16 cm

Quantity: 1

Material: Wood

Currently stored at: Shelter-2

Remarks & Recommendation: In good
condition. Could be reused directly.



ID No.: B/K 196-K 03

Name: Kunsala (Corner Strut)

Monument: Nau Dega (Bimalesvara
Temple)

Size: 113 X 10 X 16 cm

Quantity: 1

Material: Wood

Currently stored at: Shelter-2

Remarks & Recommendation: One of
the best preserved wooden struts. Can be
directly reused.



ID No.: B/K 196-K 04

Name: Kunsala (Corner Strut)

Monument: Nau Dega (Bimalesvara
Temple)

Size: 112 X 10 X 16 cm

Quantity: 1

Material: Wood

Currently stored at: Shelter-2

Remarks & Recommendation: Can be
directly reused with some tightening of
partial wings.



ID No.: B/K 196-K 05

Name: Kunsala (Corner Strut)

Monument: Nau Dega (Bimalesvara
Temple)

Size: 168 X 13 X 19 cm

Quantity: 1

Material: Wood

Currently stored at: Shelter-2

Remarks & Recommendation: Could
be reused directly.



ID No.: B/K 196-K 06

Name: Kunsala (Corner Strut)

Monument: Nau Dega (Bimalesvara
Temple)

Size: 174 X 13X19 cm

Quantity: 1

Material: Wood

Currently stored at: Shelter-2

Remarks & Recommendation: The surface is climatically eroded due to the moisture. The strength is not decreased. Some chemical treatment is necessary. Soda water wash is to be given then can be used directly.



ID No.: B/K 196-K 07

Name: Kunsala (Corner Strut)

Monument: Nau Dega (Bimalesvara
Temple)

Size: 169 X 13 X 19 cm

Quantity: 1

Material: Wood

Currently stored at: Shelter-2

Remarks & Recommendation: In
good condition. Can be directly
reused.



ID No.: B/K 196-K 08

Name: Kunsala (Corner Strut)

Monument: Nau Dega (Bimalesvara
Temple)

Size: 170 X 13 X 19 cm

Quantity: 1

Material: Wood

Currently stored at: Shelter-2

Remarks & Recommendation: The
wood as such is still well conditioned.
Phallus of the lion and small portion
below it are to be re-carved and refitted.



ID No.: - B/K 196- WIN(A) 01

Name: Ga Jhya (Big)

Monument: Bimalessvara Temple (Top storey)

Size: 205 X 115 cm

Quantity: 1

Material: Wood

Currently stored at: Shelter-2

Remarks & Recommendation: Parts are broken and missing. They are to be re-carved and refitted

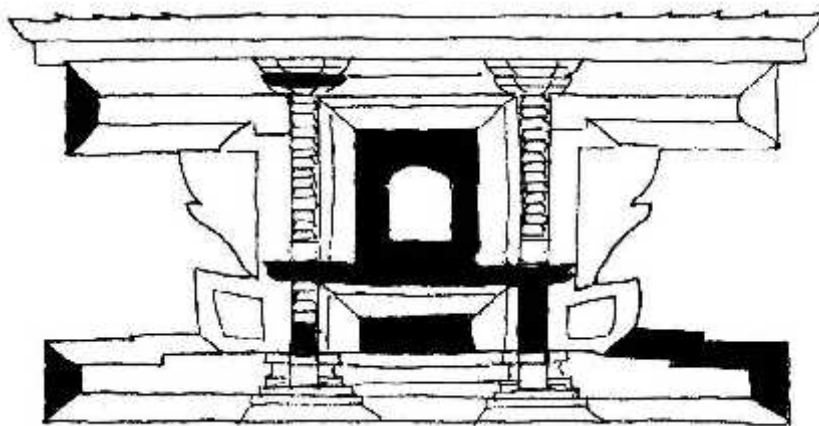

ID No.: B/K 196- WIN(A) 02

Name: Ga Jhya (Big)

Monument: Nau Dega (Bimalessvara Temple) (Top storey)

Size: 210 X 115 cm

Quantity: 1

Material: Wood

Currently stored at: Shelter-2

Remarks & Recommendation: Parts are broken and missing. They are to be re-carved and refitted

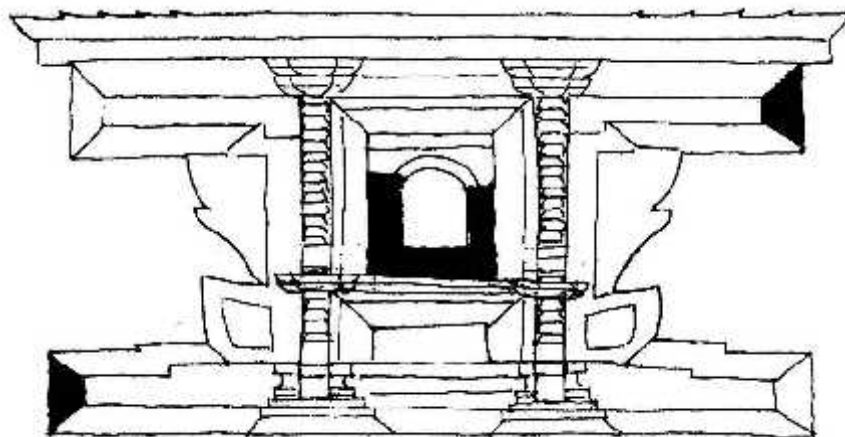

ID No.: B/K 196- WIN(A) 03

Name: Gajhya (Big)

Monument: Nau Dega (Bimalesvara Temple) (Top storey)

Size: 205 X 115 cm

Quantity: 1

Material: Wood

Currently stored at: Shelter-2

Remarks & Recommendation: Parts are broken and missing. They are to be re-carved and refitted.

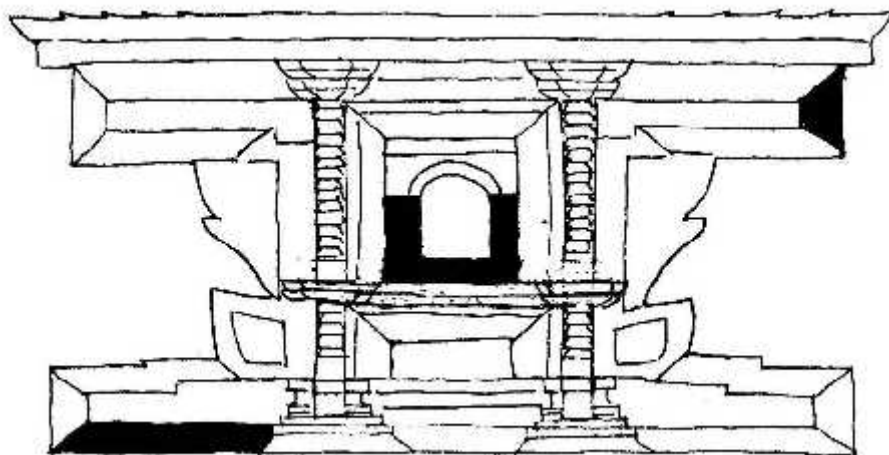

ID No.: B/K 196- WIN(A) 04

Name: Ga Jhya (Big)

Monument: Nau Dega (Bimalessvara Temple) (Top storey)

Size: 210 X 115 cm

Quantity: 1

Material: Wood

Currently stored at: Shelter-2

Remarks & Recommendation: Parts are broken and missing. They are to be re-carved and refitted

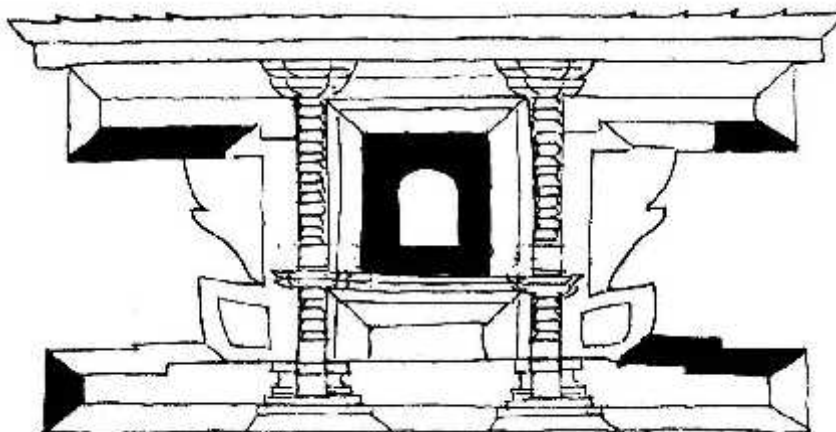

ID No.: B/K 196- WIN(A) 05

Name: Ga Jhya (Medium)

Monument: Nau Dega (Bimalesvara Temple) - Ground Storey

Size: 141 X 66 cm

Quantity: 1

Material: Wood

Currently stored at: Shelter-2

Remarks & Recommendation: Parts are broken and missing. They are shown in the drawing. They are to be re-carved and refitted.

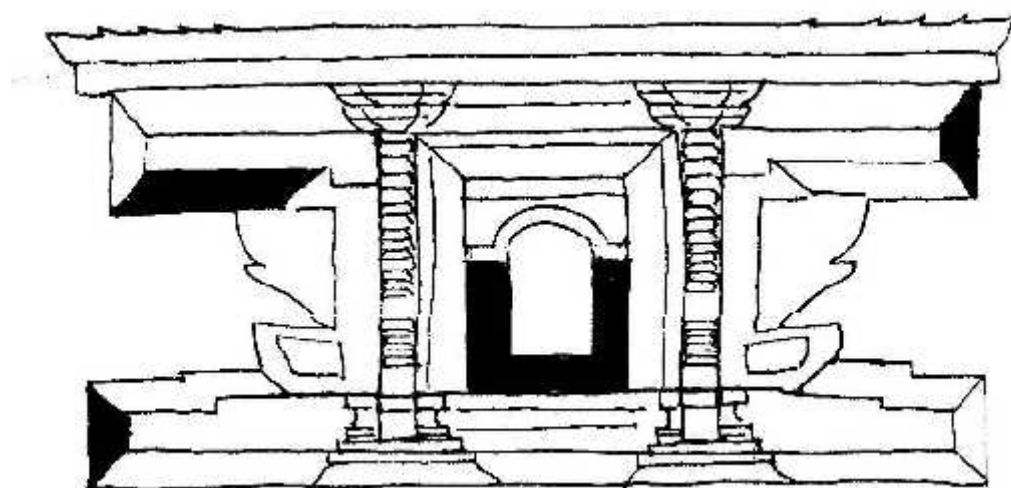

ID No.: B/K 196- WIN(A) 06

Name: Gajhya (Medium)

Monument: Nau Dega (Bimalesvara Temple) - Ground Storey

Size: 143 X 63 cm

Quantity: 1

Material: Wood

Currently stored at: Shelter-2

Remarks & Recommendation: Parts are broken and missing. They are shown in the drawing. They are to be recarved and refitted.

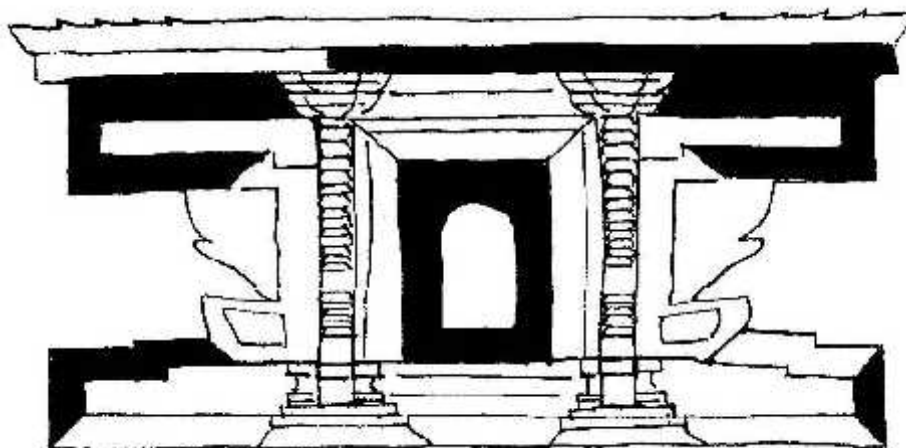

ID No.: B/K 196- WIN(A) 07

Name: Gajhya (Medium)

Monument: Nau Dega (Bimalesvara Temple) - Ground Storey

Size: 140 X 65 cm

Quantity: 1

Material: Wood

Currently stored at: Shelter-2

Remarks & Recommendation: Parts are broken and missing. They are shown in the drawing. They are to be re-carved and refitted.

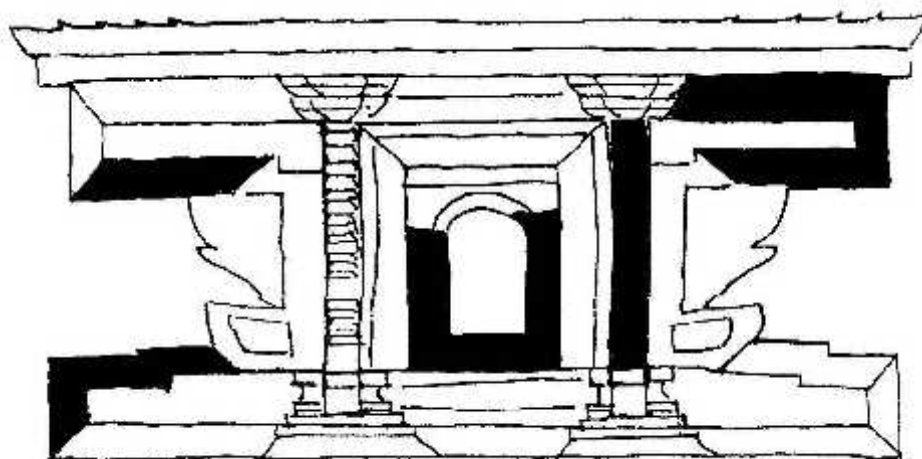

ID No.: B/K 196- WIN(A) 08

Name: Gajhya (Medium)

Monument: Nau Dega (Bimalesvara Temple) - Ground Storey

Size: 141 X 64 cm

Quantity: 1

Material: Wood

Currently stored at: Shelter-2

Remarks & Recommendation: Parts are broken and missing. They are shown in the drawing. They are to be re-carved and refitted.

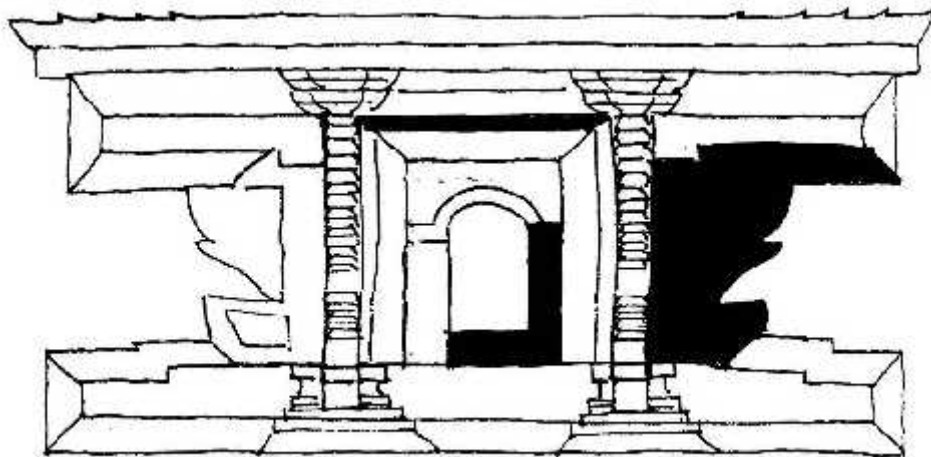

ID No.: B/K 196- WIN(A) 09

Name: Ga Jhya (Small)

Monument: Nau Dega (Bimalessvara Temple) - Ground Storey

Size: 104 X 51 cm

Quantity: 1

Material: Wood

Currently stored at: Shelter 2

Remarks & Recommendation: This is one of the best preserved windows. No parts are lost or broken. Reusable.

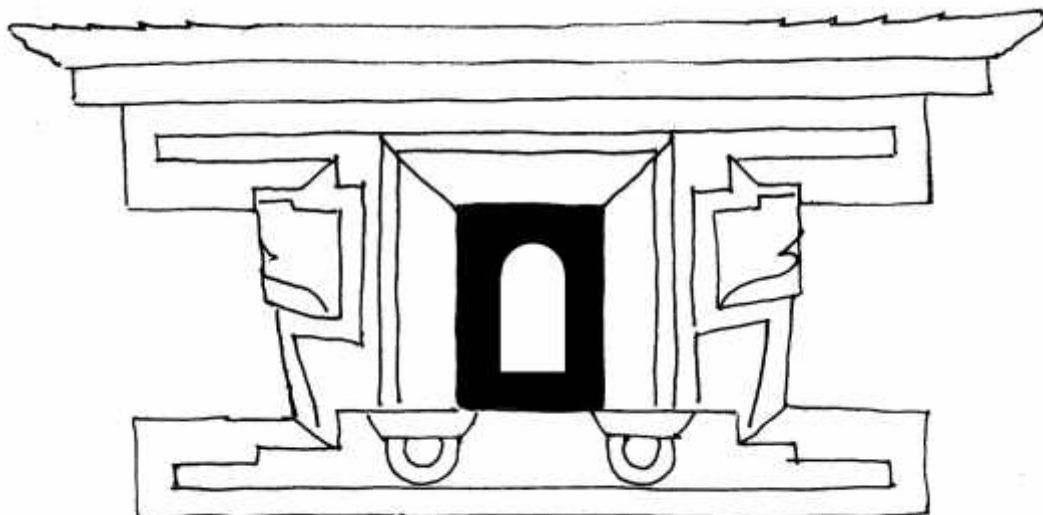

ID No.: B/K 196- WIN(A) 10

Name: Ga Jhya (Small)

Monument: Nau Dega (Bimalessvara Temple) - Ground Storey

Size: 103 X 50 cm

Quantity: 1

Material: Wood

Currently stored at: Shelter 2

Remarks & Recommendation: Recarve lost part and refit.

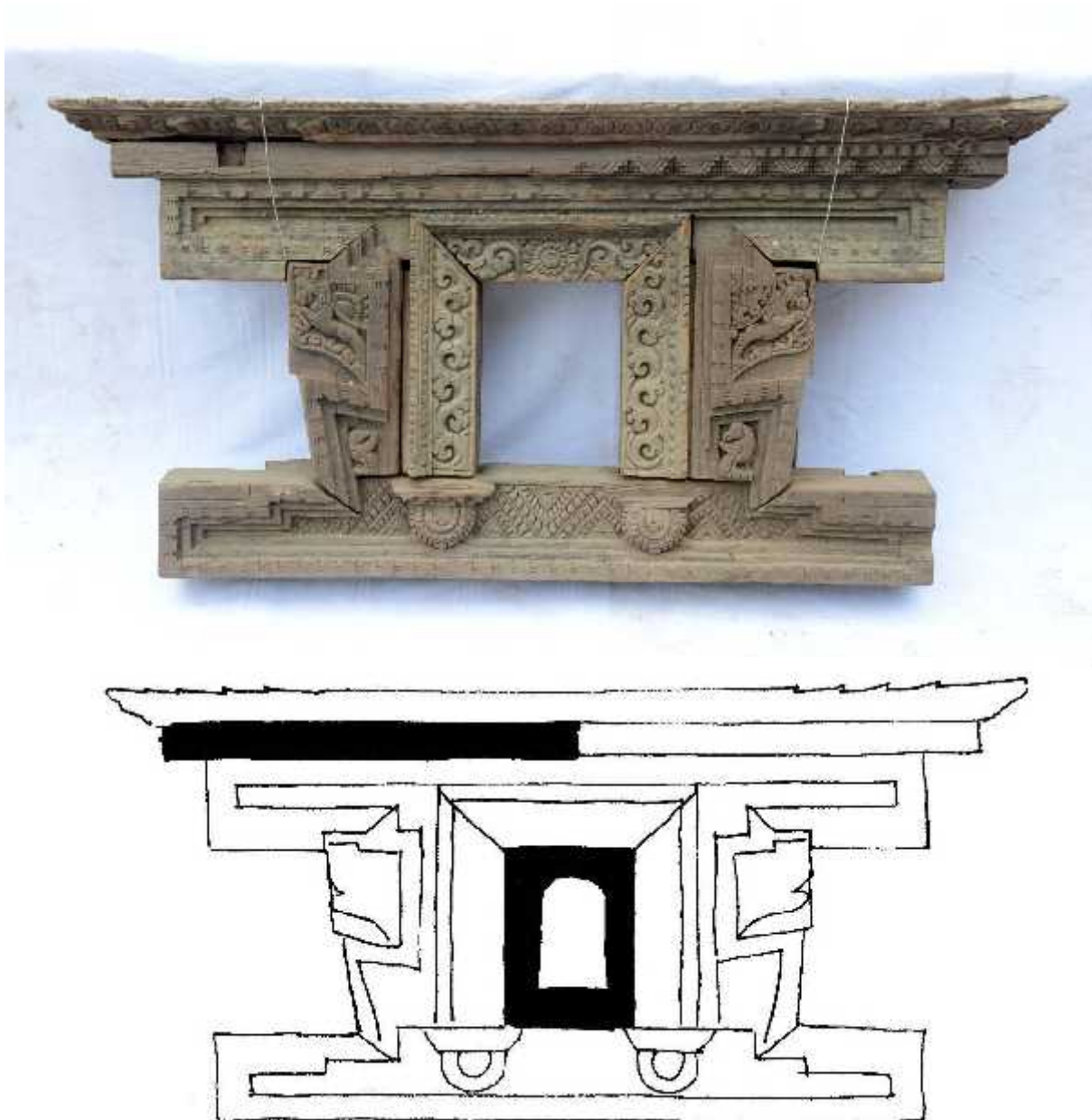

ID No.: B/K 196- WIN(A) 11

Name: Ga Jhya (Small)

Monument: Nau Dega (Bimalessvara Temple) - Ground Storey

Size: 103 X 50 cm

Quantity: 1

Material: Wood

Currently stored at: Shelter 2

Remarks & Recommendation: Intact. Reusable.

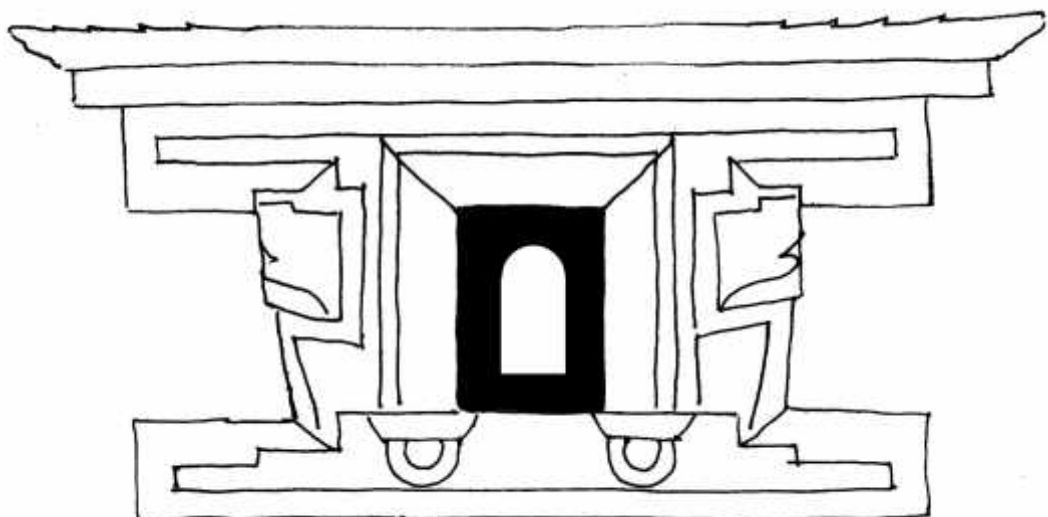

ID No.: B/K 196- WIN(A) 12

Name: Ga Jhya (Small)

Monument: Nau Dega (Bimallesvara Temple) - Ground Storey

Size: 103 X 51 cm

Quantity: 1

Material: Wood

Currently stored at: Shelter 2

Remarks & Recommendation: Intact. Reusable.

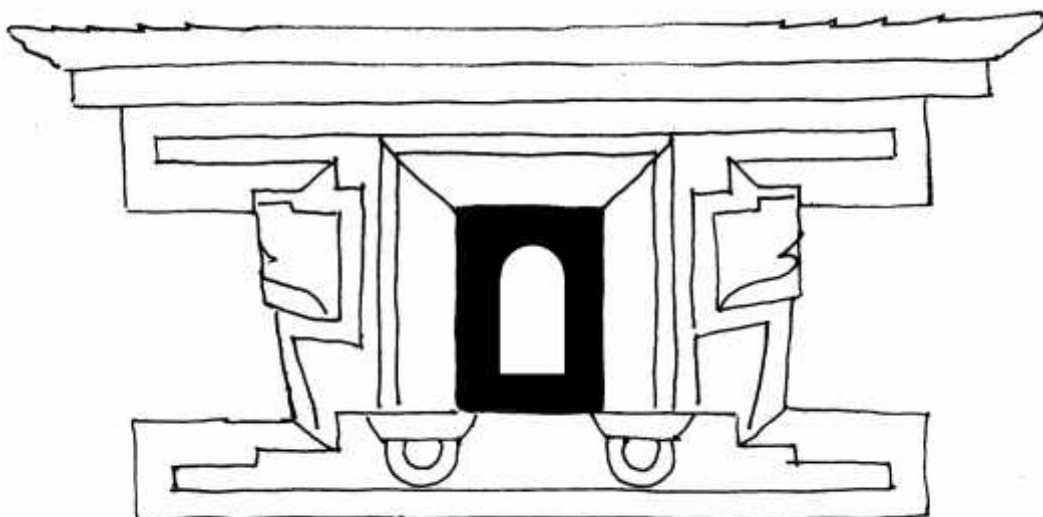

ID No.: B/K 196- WIN(A) 13

Name: Ga Jhya (Small)

Monument: Nau Dega (Bimalessvara Temple) - Ground Storey

Size: 103 X 51 cm

Quantity: 1

Material: Wood

Currently stored at: Shelter 2

Remarks & Recommendation: Recarve lost part and refit.

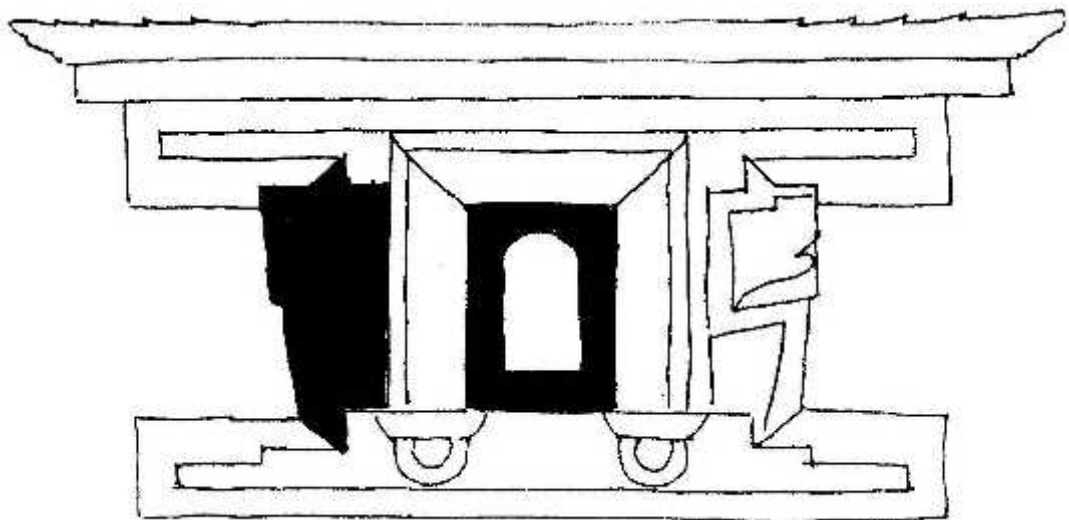

ID No.: B/K 196- WIN(A) 14

Name: Ga Jhya (Small)

Monument: Nau Dega (Bimalessvara Temple) - Ground Storey

Size: 103 X 51 cm

Quantity: 1

Material: Wood

Currently stored at: Shelter 2

Remarks & Recommendation: Intact. Reusable.

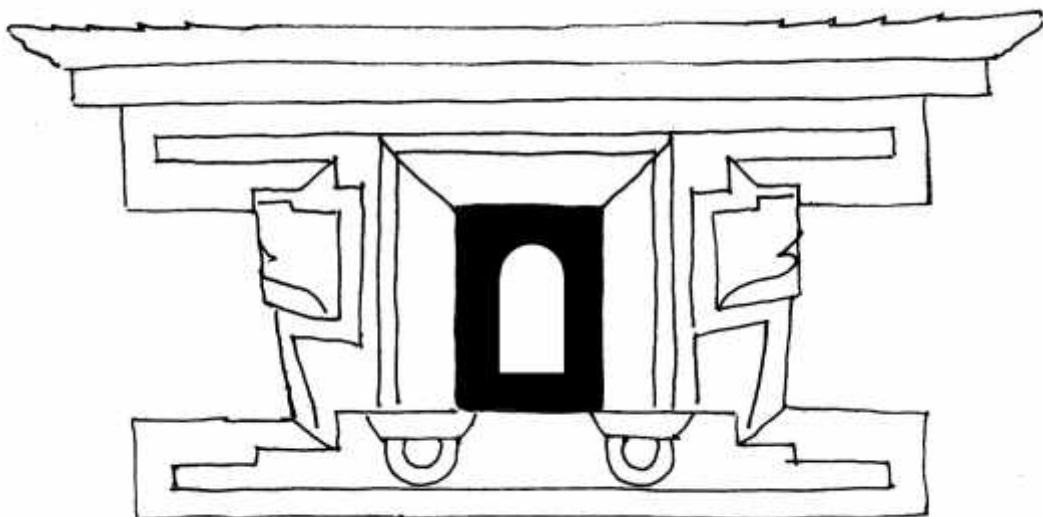

ID No.: B/K 196- WIN(A) 15

Name: Ga Jhya (Small)

Monument: Nau Dega (Bimalessvara Temple) - Ground Storey

Size: 104 X 51 cm

Quantity: 1

Material: Wood

Currently stored at: Shelter 2

Remarks & Recommendation: Recarve lost part and refit.

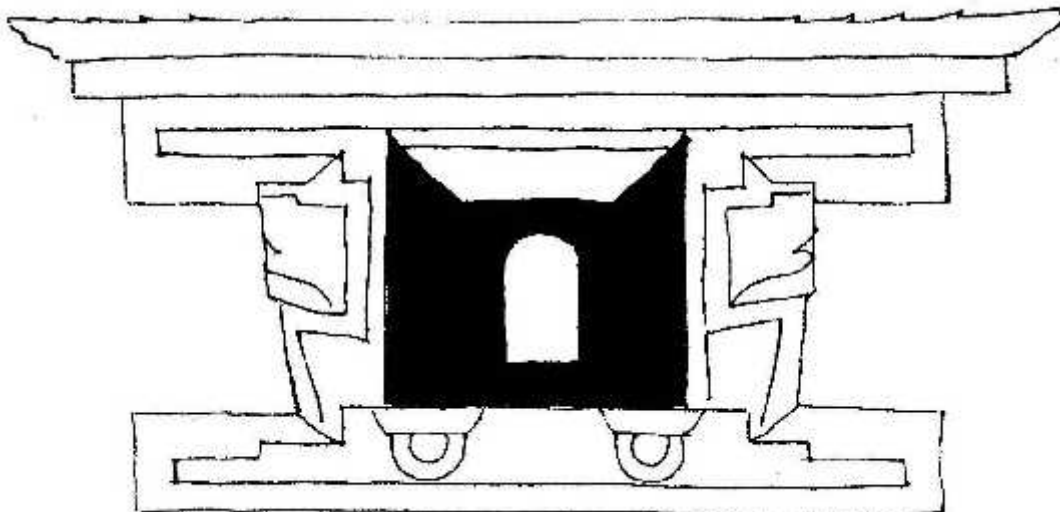

ID No.: B/K 196- WIN(A) 16

Name: Ga Jhya (Small)

Monument: Nau Dega (Bimalesvara Temple) - Ground Storey

Size: 92 X 46 cm

Quantity: 1

Material: Wood

Currently stored at: Shelter 2

Remarks & Recommendation: Intact. Reusable.

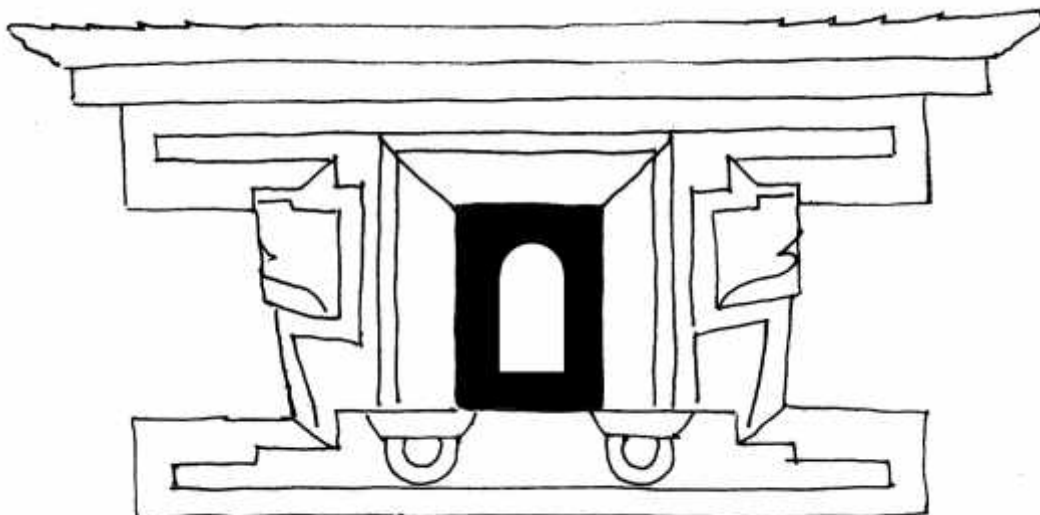

ID No.: B/K 196- WIN(B) 01

Name: Yaaku Jhya

Monument: Nau Dega (Bimallesvara Temple).

Size: 40 X 74 cm

Quantity: 1

Material: Wood

Currently stored at: Shelter-2

Remarks & Recommendation: Parts are broken and missing. They are shown in the drawing. They are to be re-carved and refitted.

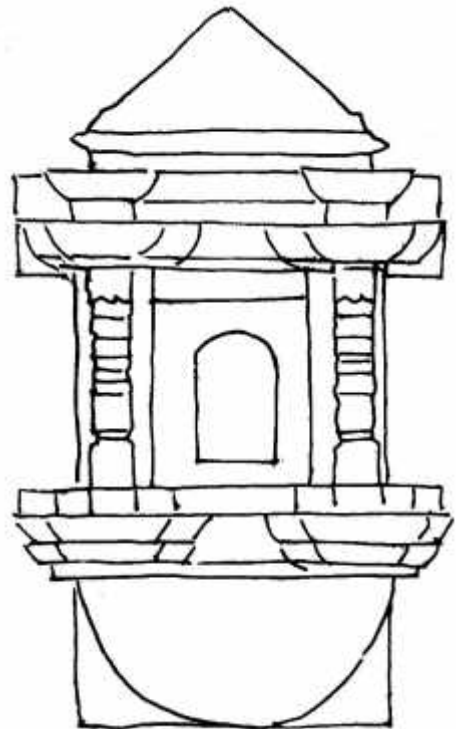

ID No.: B/K 196- WIN(B) 02

Name: Yaaku Jhya.

Probably Monument: Nau Dega (Bimallesvara Temple).

Size: 40 X 73 cm

Quantity: 1

Material: Wood

Currently stored at: Shelter-2

Remarks & Recommendation: Parts are broken and missing. They are shown in the drawing. They are to be re-carved and refitted.

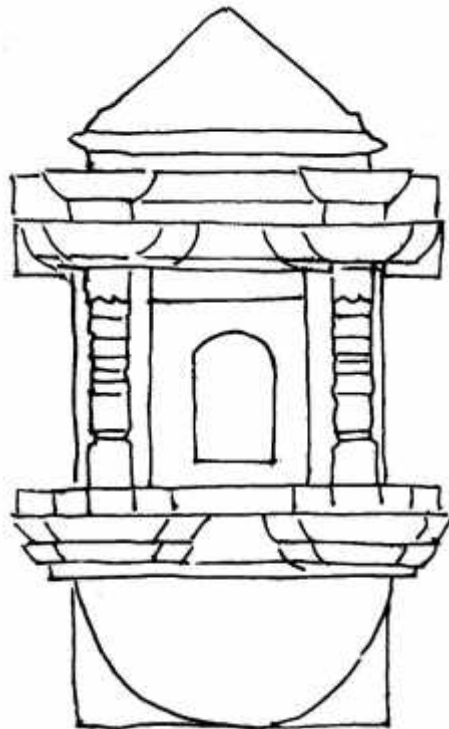

ID No.: B/K 196- WIN(B) 03

Name: Yaaku Jhya

Monument: Nau Dega (Bimalesvara Temple)

Size: 40 X 73 cm

Quantity: 1

Material: Wood

Currently stored at: Shelter-2

Remarks & Recommendation: Parts are broken and missing. They are shown in the drawing. They are to be re-carved and refitted.

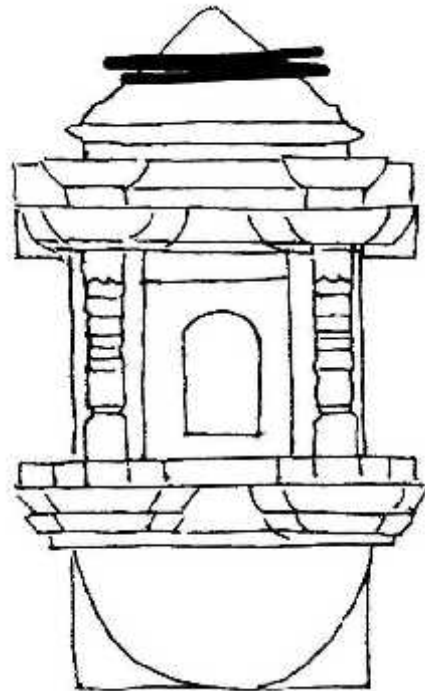

ID No.: B/K 196- WIN(B) 04

Name: Yaaku Jhya

Monument: Nau Dega (Bimalesvara Temple)

Size: 41 X 62 cm

Quantity:1

Material: Wood

Currently stored at: Shelter-2

Remarks & Recommendation: Parts are broken and missing. They are shown in the drawing. They are to be re-carved and refitted.

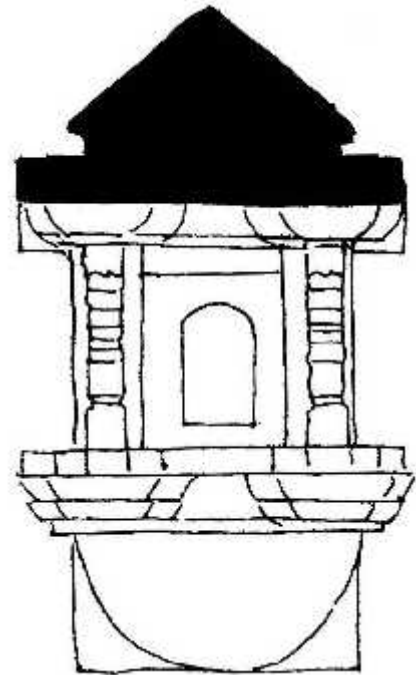

ID No.: B/K 196- WIN(B) 05

Name: Yaaku Jhya.

Monument: Nau Dega (Bimalessvara Temple).

Size: 64 X 40 cm

Quantity: 1

Material: Wood

Currently stored at: Shelter-2

Remarks & Recommendation: Parts are broken and missing. They are shown in the drawing. They are to be re-carved and refitted.

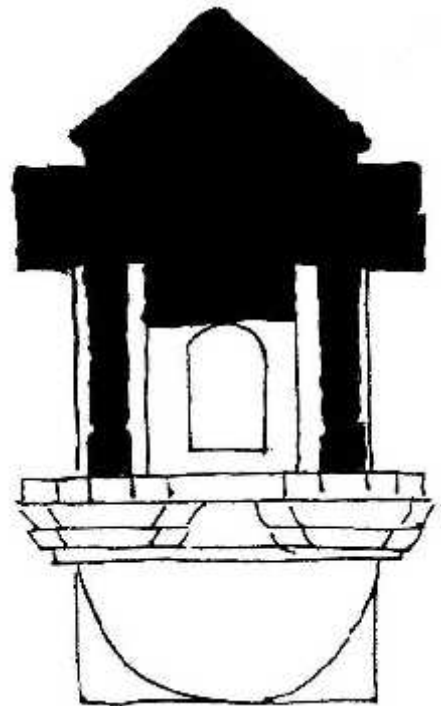

ID No.: B/K 196- WIN(B) 06

Name: Yaaku Jhya.

Monument: Nau Dega (Bimalessvara Temple).

Size: 54 X 40 cm

Quantity: 1

Material: Wood

Currently stored at: Shelter-2

Remarks & Recommendation: Parts are broken and missing. They are shown in the drawing. They are to be re-carved and refitted.

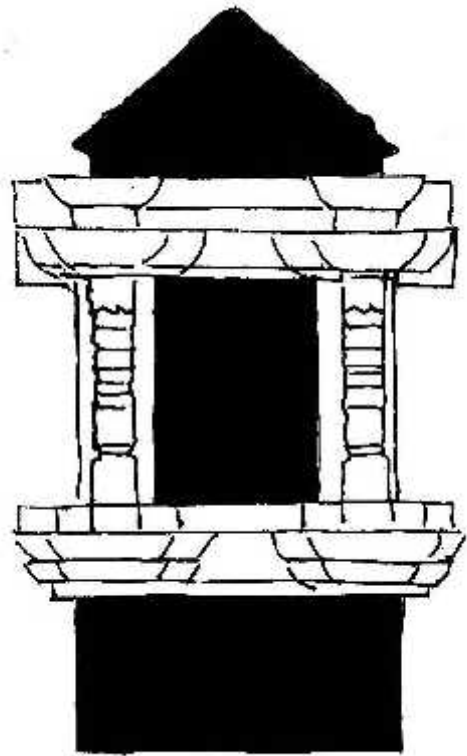

ID No.: B/K 196- WIN(B) 07

Name: Yaaku Jhya.

Monument: Nau Dega (Bimallesvara Temple).

Size: 64 X 40 cm

Quantity: 1

Material: Wood

Currently stored at: Shelter-2

Remarks & Recommendation: Parts are broken and missing. They are shown in the drawing. They are to be re-carved and refitted.

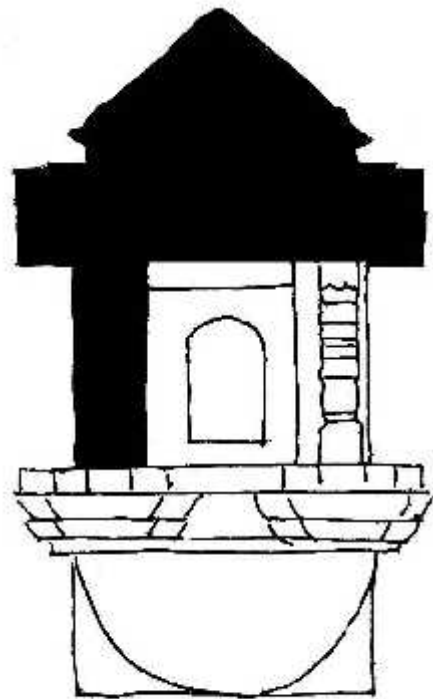

ID No.: B/K 196- Door 01

Name: Door 1

Monument: Nau Dega (Bimalesvara Temple)

Size: 265 X 160 cm

Quantity: 1

Material: Wood

Currently stored at: Shelter-2

Remarks & Recommendation: This door is nearly complete except a small part broken off at the corner of *Lancho*. (Extended bracket of the door) The broken parts of the structure are to be re-carved and fitted. (The parts to be replaced will be shown in the drawing in final report)

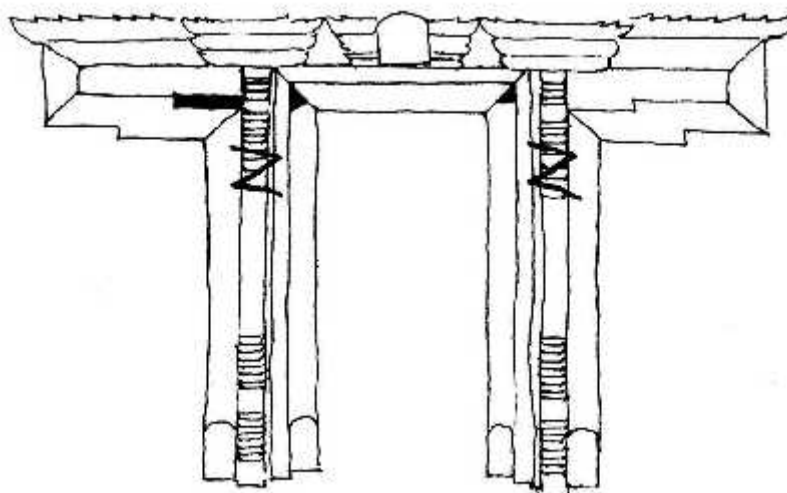

ID No.: B/K 196- Door 02

Name: Door 2

Monument: Nau Dega (Bimalessvara Temple)

Size: 265 X 160

Quantity: 1

Material: Wood

Currently stored at: Shelter-2

Remarks & Recommendation: Top portion, left and right ends of the *Lancho* is gone off. The lost parts are to be replaced as soon in the drawing. (The parts to be replaced will be shown in drawing in final report)

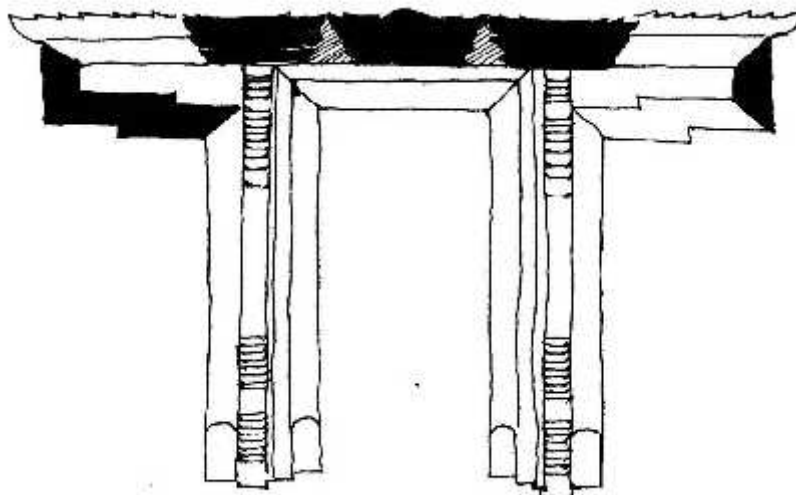

ID No.: B/K 196- Door 03

Name: Door 3

Monument: Nau Dega (Bimalessvara Temple)

Size: 265 X 160 cm

Quantity: 1

Material: Wood

Currently stored at: Shelter-2

Remarks & Recommendation: Among the four, this one is most damaged. The flaked off parts are shown in matching. All they are to be re-carved and refitted. The lost parts have to be re-carved and refitted. (The parts to be replaced will be shown in the drawing in final report)

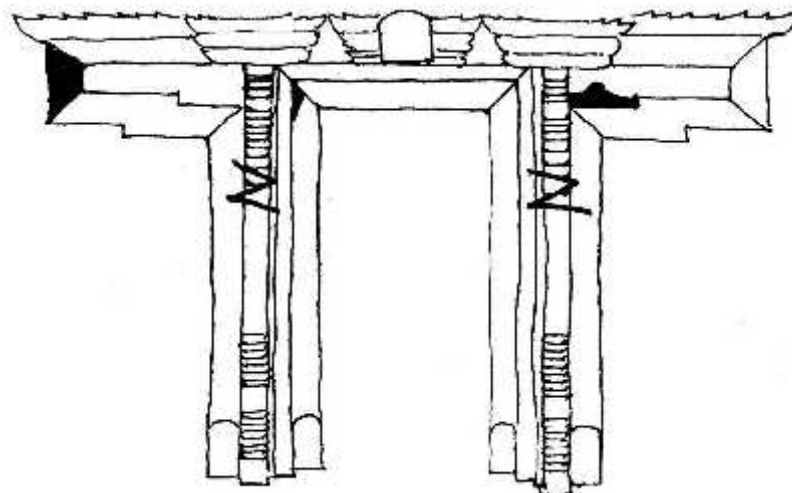

ID No.: B/K 196- Door 04

Name: Door 4

Monument: Nau Dega (Bimalessvara Temple)

Size: 265 X 160 cm

Quantity: 1

Material: Wood

Currently stored at: Shelter-2

Remarks & Recommendation: Very small portion has been flaked off. Rest one *tolanthan* is broken on the left one of the door. Rest is ok. Slight mending is enough.

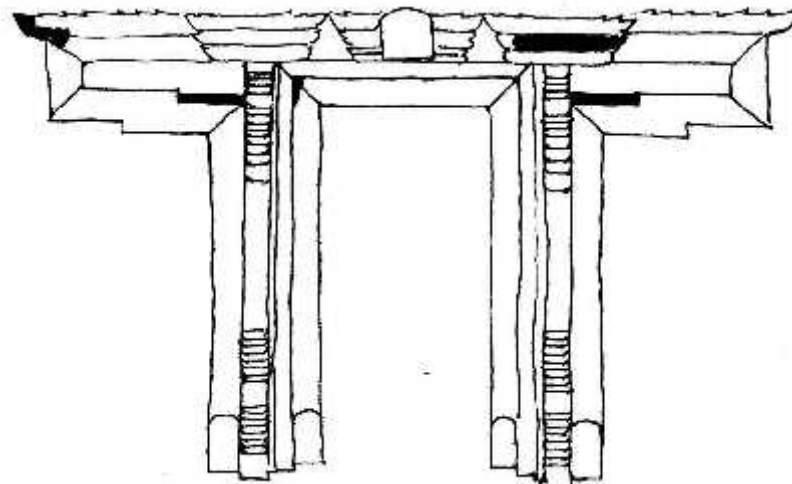

ID No.: B/K 196-PL 01

Name: The main pillars of the colonnade.

Monument: Nau Dega (Bimalessvara Temple)

Size: 175 X 20 X 20 cm

Quantity: 12 (twelve in number)

Material: Wood.

Currently stored at: Shelter-2

Remarks & Recommendation: Excellent to reuse having little surface cleaning on top and bottom. Top notches of all pillars are broken off therefore new notches are to be used.



ID no. : B/K 202-Meth 1

Name: Meth

Monument: Nau Dega (Bimalesvara Temple)

Size: 105 X 15 X 20 cm (full meth), 85 X 15 X 20 cm (half meth)

Quantity: 8 nos. (full meth), 8 nos. (half meth)

Material: Wood

Currently store at: Shelter 2

Remarks & Recommendation: All reusable.



Code no. : B/K 202-Ch 1

Name: Chakulaan

Monument: Nau Dega (Bimallesvara Temple)

Size: 40 X 38 cm

Quantity: 9

Material: Wood

Currently store at: Shelter 2

Remarks & Recommendation: 3 are lost. 3 among recoverd are broken. 6 are reusable. Restore the broken one with tightening and remake the lost one copying from the saved ones.



Code no. : B/K 202-Dh 1

Name: Dhalinkhwa

Monument: Nau Dega (Bimalesvara Temple)

Size:

Quantity: More than 100.

Material: Wood

Currently store at: Shelter 1

Remarks & Recommendation: Almost all that are recovered are in good condition.



PUN DEGA (TRAILOKYA MOHAN TEMPLE) (B/K-202)

01. Struts

02. Kunsala

03. Windows

04. Doors

05. Pillar`

06. Meth

07. Chakulaan

08. Dhalinkhwa

09. Stone Icon

ID No.: B/K 202-TDL 01

Name: Fish incarnation of Vishnu.

Monument: Pu Dega (Trailokya Mohan Temple)

Size: 174 X 29 X 15 cm

Quantity: 1

Material: Wood

Currently stored at: Shelter 1

Remarks & Recommendations: The part above the head of the main figure is cracked vertically and extends down to the feet. Both front hands are gone rest is still ok and can be reused with giving supports from both sides - right and left. Give the supports on both sides and reuse it again providing a horizontal knot.



ID No.: B/K 202-TDL 02

Name: Kacchhapa avatara of Vishnu.

Monument: Pu Dega (Trailokya Mohan Temple)

Size: 173 X 31 X 16 cm

Quantity: 1

Material: Wood

Currently stored at: Shelter 1

Remarks & Recommendations In totality the strut is rotten to the left half. With back support it could be reused still. Broken vertically at the middle. Left half vertically is rotten, still could be reused giving two supporting beams.



ID No.: B/K 202-TDL 03

Name: Varah Avatara of Vishnu.

Monument: Pu Dega (Trailokya Mohan Temple)

Size: 177 X 29 X 17cm

Quantity: 1

Material: Wood

Currently stored at: Shelter 1

Remarks & Recommendations: Cracked vertically at the middle. The head is also broken off leaving the small part of snout. Left leg is disconnected with the foot. Could be reused giving supports on both sides.



ID No.: B/K 202-TDL 04

Name: Fish incarnation of Vishnu.

Monument: Pu Dega (Trailokya Mohan Temple)

Size: 169 X 28 X 13 cm

Quantity: 1

Material: Wood

Currently stored at: Shelter 1

Remarks & Recommendations: Vertical cracked at the middle still strong enough for reuse if it is given support from two sides.



ID No.: B/K 202-TDL 05

Name: Kalki avatar of Vishnu.

Monument: Pu Dega (Trailokya Mohan Temple)

Size: 163 X 28 X 16cm

Quantity: 1

Material: Wood

Currently stored at: Shelter 1

Remarks & Recommendations: Vertical cracked at the middle still strong enough for reuse if it is given support from two sides. One of left hand with *chakra* is broken off. Could be reused with giving support from both sides.



ID No.: B/K 202-TDL 06

Name: Figure of Purusottama?

Monument: Pu Dega (Trailokya Mohan Temple)

Size: 176 X 28 X 16 cm

Quantity: 1

Material: Wood

Currently stored at: Shelter 1

Remarks & Recommendations: Right part of the main figure is rotten away due to the water percolation left leg is broken leaving the foot. Right main hand is no more. Can be reused giving support and bolding horizontally.



ID No.: B/K 202-TDL 07

Name: The figure of Vaman?

Monument: Pu Dega (Trailokya Mohan Temple)

Size: 174 X 30 X 18 cm

Quantity: 1

Material: Wood

Currently stored at: Shelter 1

Remarks & Recommendations: The portion below the feet is vertically cracked. Rest is ok except the erosion due to bird droppings and moisture. Three knot bolts needs to be fixed in three places up middle and on the bottom then can be reused.



ID No.: B/K 202-TDL 08

Name: The figure of Vasudeva.

Monument: Pu Dega (Trailokya Mohan Temple)

Size: 174 X 23 X 12 cm

Quantity: 1

Material: Wood

Currently stored at: Shelter 1

Remarks & Recommendations: Give a knot bolting on top
and reuse it.



ID No.: B/K 202-TDL 09

Name: Divine figure of Govinda.

Monument: Pu Dega (Trailokya Mohan Temple)

Size: 175 X 20 X 11cm

Quantity: 1

Material: Wood

Currently stored at: Shelter 1

Remarks & Recommendations: Upper right portion is broken off and there is a vertical crack down to the middle, otherwise except climatic erosion rest is still fine and strong. Half the portion is cracked to the middle from top. But right half on top is flaked off. Could be reused with two supports.



ID No.: B/K 202-TDL 10

Name. : Bishnu Tunal.

Monument: Pu Dega (Trailokya Mohan Temple)

Size: 147 X 16 X 8 cm

Quantity: 1

Material: Wood

Currently stored at: Shelter 1

Remarks & Recommendations. : Good and strong. Slightly coloured. The carving is rough and not much finished. Rocky pattern pedestal - No riding vehicle. Though looks strong advised to give support beams on left and right at least for homogenous look.



ID No.: B/K 202-TDL 11

Name: Divine figure of a Salabhanjika.

Monument: Pu Dega (Trailokya Mohan Temple)

Size: (165+8) X 30 X 15cm.

Quantity: 1

Material: Wood

Currently stored at: Shelter 1

Remarks & Recommendations: Figure almost disfigured and the vertical crack and flaked off due to old age. Not recommendable for reuse anymore. Badly cracked vertically at the middle. Not advisable to reuse. Recommended for museum piece.



ID No.: B/K 202-TDL 12

Name: Divine figure of a Goddess.

Monument: Pu Dega (Trailokya Mohan Temple)

Size: (163+10) X 29 X 15cm

Quantity: 1

Material: Wood

Currently stored at: Shelter 1

Remarks & Recommendations: Everything intact except the top and half below is cracked. Only mid portion is still joined together. Could be reused with support and strengthening from the back.



ID No.: B/K 202-TDL 13

Name: Strut having the figure of Rukmini.

Monument: Pu Dega (Trailokya Mohan Temple)

Size: 179 X 28 X 15cm

Quantity: 1

Material: Wood

Currently stored at: Shelter 1

Remarks & Recommendations: Cracked vertically. Needs
back support. If possible horizontal knot bolting.



ID No.: B/K 202-TDL 14

Name: Strut having the figure of celestial nymph.

Monument: Pu Dega (Trailokya Mohan Temple)

Size: 174 X 30 X 18 cm

Quantity: 1

Material: Wood

Currently stored at: Shelter 1

Remarks & Recommendations: Seems intact but needs a horizontal knot bolting at the bottom.



IID No.: B/K 202-TDL 15

Name: A form of Vishnu.

Monument: Pu Dega (Trailokya Mohan Temple)

Size: 170 X 26 X 16 cm

Quantity: 1

Material: Wood

Currently stored at: Shelter 1

Remarks & Recommendations: Vertical cracked at the middle still strong enough for reuse if it is given support from two sides.



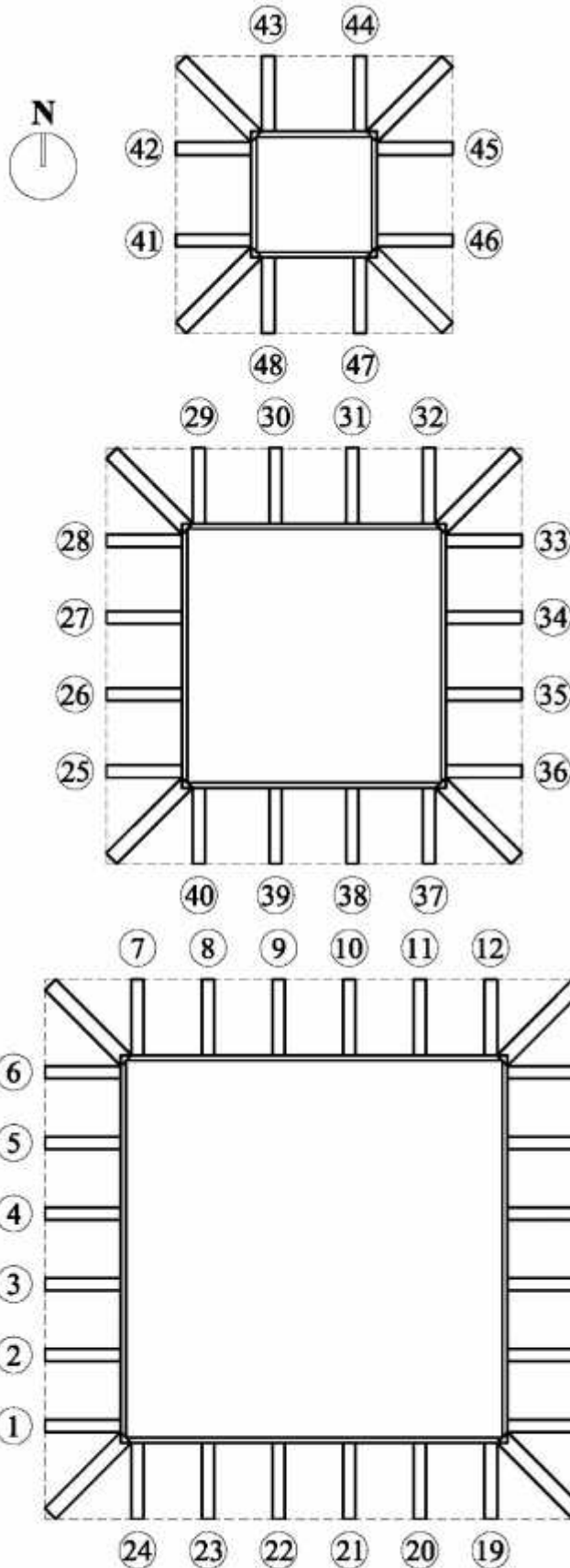

Positions if 24 aspects of Vishnu is conceived Possible positions of struts that are recovered

1 Vasudeva	1 Matsya
2 Keshav	2 Kurma
3 Narayan	3 Varaha
4 Madhav	4 Narasimha
5 Purushottam	5 Vamana
6 Parasuram	6 Adhokshyaja
7 Sankarsana	7 N/A
8 Govinda	8 Govinda
9 Vishnu	9 Rama
10 Madhusudan	10 Kalki
11 Achyuta	11 Purushottam
12 Upendra	12 N/A
13 Pradyumna	13 Satyabhama
14 Trivikram	14 Haymee
15 Narasimha	15 Rukminee
16 Janardana	16 Apsara (Nymph)
17 Vamana	17 Ganga
18 Shreedhar	18 Yamuna ?
19 Aniruddha	19 N/A
20 Hrisikesh	20 N/A
21 Padmanabha	21 N/A
22 Damodar	22 N/A
23 Hari	23 N/A
24 Krishna	24 N/A
25-48 (Plain)	25-48 (Plain)

PUN DEGA: (TRAILOKYA MOHAN TEMPLE)
(Strut Plan)

ID No.: B/K 202 K-01

Name: Kunsala (Corner Strut)

Monument: Pu Dega (Trailokya
Mohan Temple)

Size: 213 X 18 X 23 cm

Quantity: 1

Material: Wood.

Currently stored at: Shelter 1

Remarks & Recommendation: Head
portion is cracked from to almost half.
Therefore should bolted with iron knot
and refixed.



ID No.: B/K 202 K-02

Name: Kunsala (Corner Strut)

Monument: Pu Dega (Trailokya Mohan
Temple)

Size: 223 X 14 X 20 cm

Quantity: 1

Material: Wood.

Currently stored at: Shelter 1

Remarks & Recommendation: Almost
intact. Could be reused



ID No.: B/K 202 K-03

Name: Kunsala (Corner Strut)

Monument: Pu Dega (Trailokya Mohan
Temple)

Size: 228 X 20 X 20 cm

Quantity: 1

Material: Wood.

Currently stored at: Shelter 1

Remarks and Recommendation: Re-
carve the head and fix then.



ID No.: B/K 202 K-04

Name: Kunsala (Corner Strut)

Monument: Pu Dega (Trailokya Mohan
Temple)

Size: 236 X 20 X 25 cm

Quantity: 1

Material: Wood.

Currently stored at: Shelter 1

Remarks & Recommendation: Still can be
used, the face of the *kinnar* is flaked off and
the half of the top is cracked.

Give a knot bolting from back and then can be
reused.



ID No.: B/K 202 K-05

Name: Kunsala (Corner Strut):

Monument: Pu Dega (Trailokya Mohan
Temple)

Size: 241 X 20 X 25 cm

Quantity: 1

Material: Wood.

Currently stored at: Shelter 1

Remarks & Recommendation: Partially
cracked at the middle at top and bottom.

Give two knot bolts and reuse.



ID No.: B/K 202 K-06

Name: Kunsala (Corner Strut)

Monument: Pu Dega (Trailokya Mohan
Temple)

Size: 233 X 23 X 25 cm

Quantity: 1

Material: Wood.

Currently stored at: Shelter 1

Remarks & Recommendation: Still in good
condition. Can be reused.



ID No.: B/K 202 K-07

Name: Kunsala (Corner Strut)

Monument: Pu Dega (Trailokya
Mohan Temple)

Size: 175 X 23 X 20 cm

Quantity: 1

Material: Wood.

Currently stored at: Shelter 1

Remarks & Recommendation:

Bottom portion is cracked with big
fall off. Fill the gap at bottom then
can be reused. Give a wash.



ID No.: B/K 202 K-08

Name: Kunsala (Corner Strut)

Monument: Pu Dega (Trailokya Mohan
Temple)

Size: 185 X 20 X 20 cm

Quantity: 1

Material: Wood.

Currently stored at: Shelter 1

Remarks & Recommendation: Cracked
thoroughly from top to bottom with
flaked off head. Cracked thoroughly from
top to bottom with flaked off head. Needs
extra full strengthening for reusing it.



ID No.: B/K 202 K-09

Name: Kunsala (Corner Strut)

Monument: Pu Dega (Trailokya
Mohan Temple)

Size: 178 X 20 X 20 cm

Quantity: 1

Material: Wood.

Currently stored at: Shelter 1

Remarks & Recommendation.:

Cracked almost thoroughly at top and
bottom. Give the knot bolts on top and
bottom then can be reused.



ID No.: B/K 202 K-10

Name: Kunsala (Corner Strut)

Monument: Pu Dega (Trailokya
Mohan Temple)

Size: 180 X 15 X 18 cm

Quantity: 1

Material: Wood.

Currently stored at: Shelter 1

Remarks & Recommendation: Almost
in good condition. Remake the figure of
kinnara then give a knot bolt on bottom
and reuse it.



ID No.: B/K 202-WIN(A) 01

Name: Gaa Jhyaa

Monument: Pu Dega (Middle Storey)

Size: 128 X 235 cm

Quantity: 1

Material: Wood

Currently stored at: Trishul Chowk.

Remarks & Recommendations: The lost parts and unusable portions are to be recarved to make the window complete.

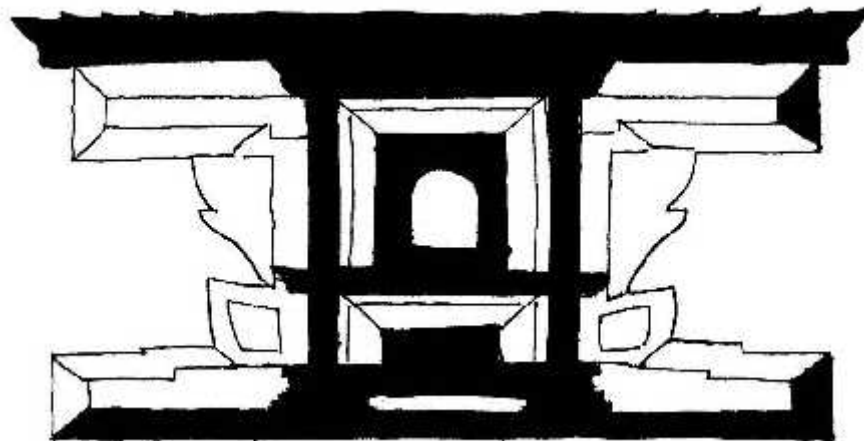

ID No.: B/K 202-WIN(A) 02

Name: Gaa Jhyaa

Monument: Pu Dega (Middle Storey)

Size: 128 X 235 cm

Quantity: 1

Material: Wood

Currently stored at: Trishul Chowk.

Remarks & Recommendations : The lost parts and unusable portions are to be recarved to make the window complete.

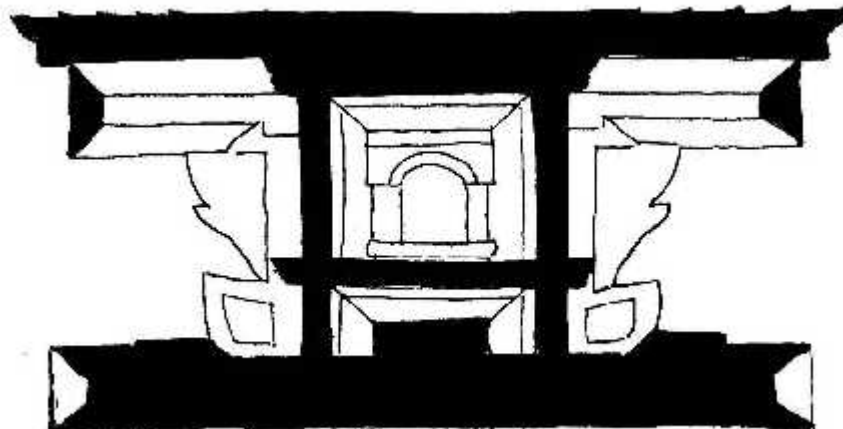

ID No.: B/K 202-WIN(A) 03

Name: Gaa Jhyaa

Monument: Pu Dega (Middle Storey)

Size: 128 X 235 cm

Quantity: 1

Material: Wood

Currently stored at: Trishul Chowk.

Remarks & Recommendations: The lost parts and unusable portions are to be re-carved to make the window complete.

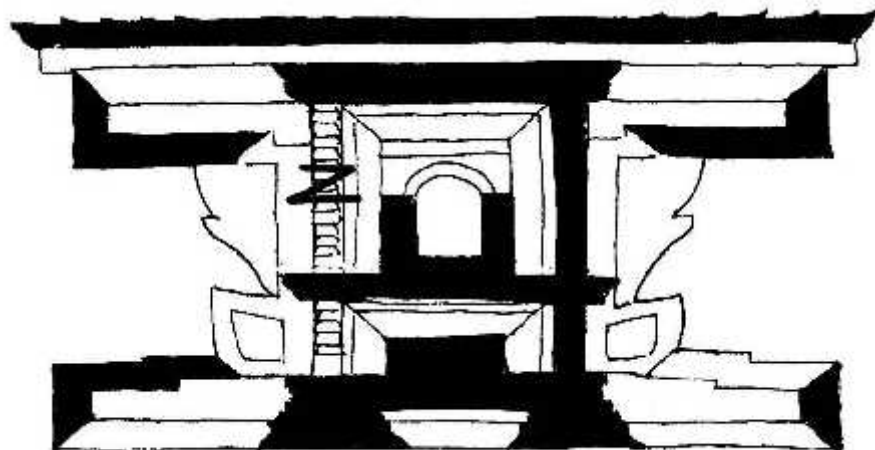

ID No.: B/K 202-WIN(A) 04

Name: Gaa Jhyaa

Monument: Pu Dega (Middle Storey)

Size: (Varies)

Quantity: 1

Material: Wood

Currently stored at: Trishul Chowk.

Remarks & Recommendations: The lost parts and unusable portions are to be recarved to make the window complete.

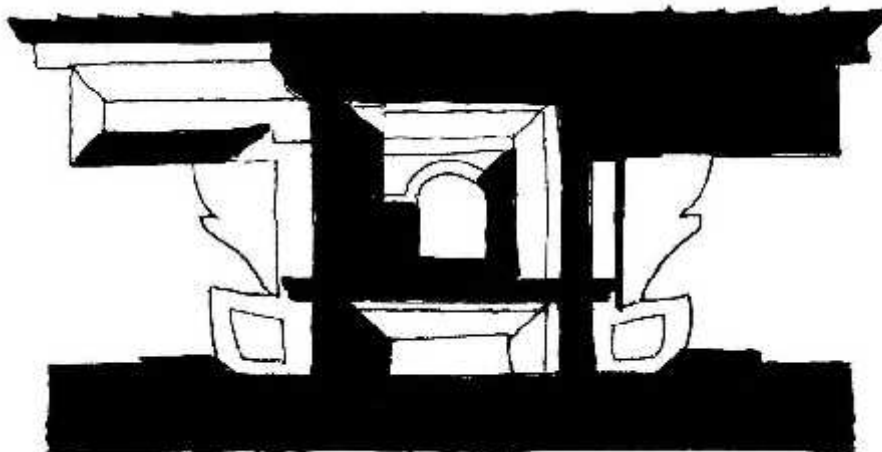

ID No.: B/K 202-WIN(A) 05

Name: Gaa Jhyaa

Monument: Pu Dega (Top Storey)

Size: 100 X 180 cm

Quantity: 1

Material: Wood

Currently stored at: Trishul Chowk.

Remarks & Recommendations: The lost parts and unusable portions are to be recarved to make the window complete.

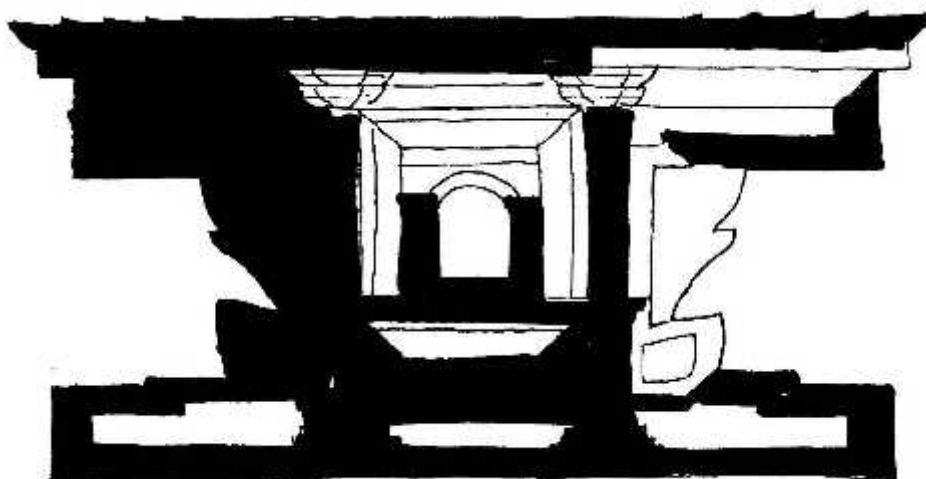

ID No.: B/K 202-WIN(A) 06

Name: Gaa Jhyaa

Monument: Pu Dega (Top Storey)

Size: 100 X 180 cm

Quantity: 1

Material: Wood

Currently stored at: Trishul Chowk.

Remarks & Recommendations: The lost parts and unusable portions are to be recarved to make the window complete.

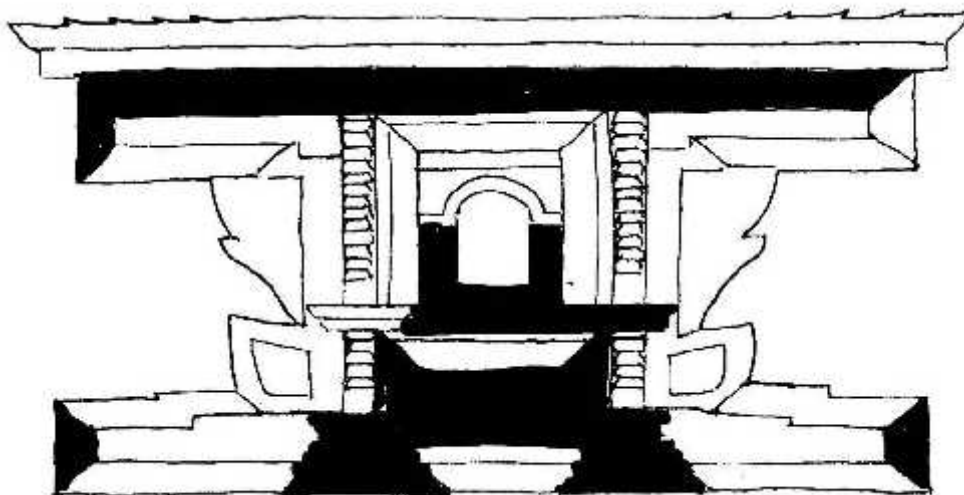

ID No.: B/K 202-WIN(A) 07

Name: Gaa Jhyaa

Monument: Pu Dega (Top Storey)

Size: (Varies)

Quantity: 1

Material: Wood

Currently stored at: Trishul Chowk.

Remarks & Recommendations: The lost parts and unusable portions are to be recarved to make the window complete.

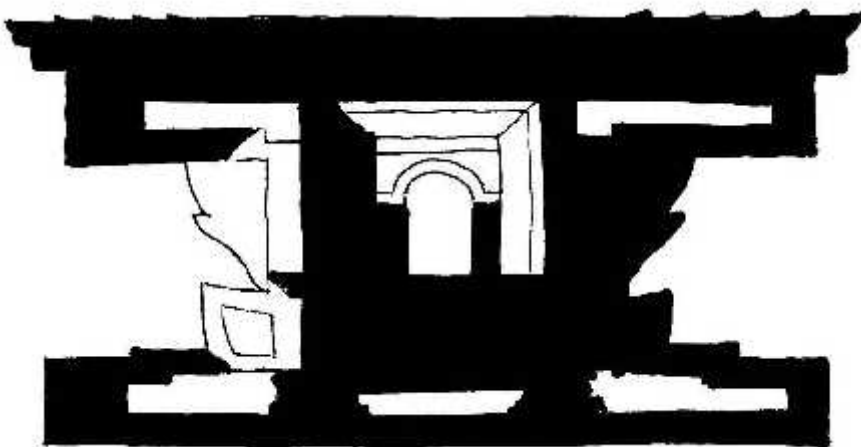

ID No.: B/K 202-WIN(A) 08

Name: Gaa Jhyaa (Side)

Monument: Pu Dega (Ground Storey)

Size: 104 X 150 cm

Quantity: 1

Material: Wood

Currently stored at: Trishul Chowk.

Remarks & Recommendations: The lost parts and unusable portions are to be recarved to make the window complete.

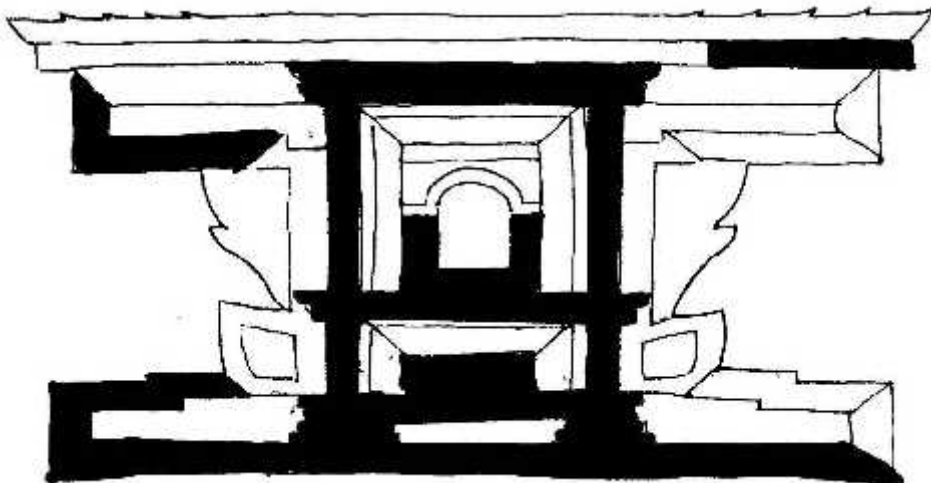

ID No.: B/K 202-WIN(A) 09

Name: Gaa Jhyaa (Side)

Monument: Pu Dega (Ground Storey)

Size: 104 X 150 cm

Quantity: 1

Material: Wood

Currently stored at: Trishul Chowk.

Remarks & Recommendations: The lost parts and unusable portions are to be recarved to make the window complete.

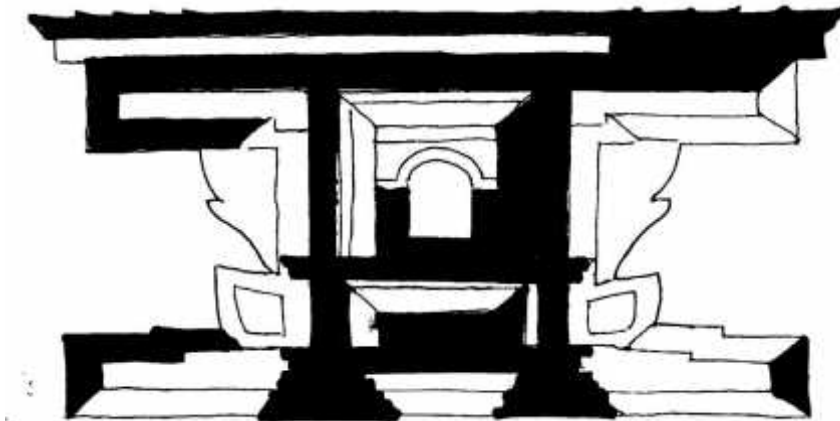

ID No.: B/K 202-WIN(A) 10

Name: Gaa Jhyaa (Side)

Monument: Pu Dega (Ground Storey)

Size: 104 X 150 cm

Quantity: 1

Material: Wood

Currently stored at: Trishul Chowk.

Remarks & Recommendations: The lost parts and unusable portions are to be recarved to make the window complete.

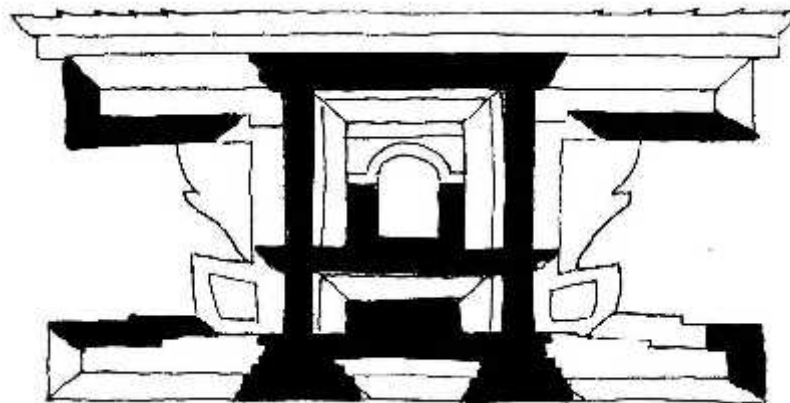

ID No.: B/K 202-WIN(A) 11

Name: Gaa Jhyaa (Side)

Monument: Pu Dega (Ground Storey)

Size: 104 X 150 cm

Quantity: 1

Material: Wood

Currently stored at: Trishul Chowk.

Remarks & Recommendations: The lost parts and unusable portions are to be recarved to make the window complete.

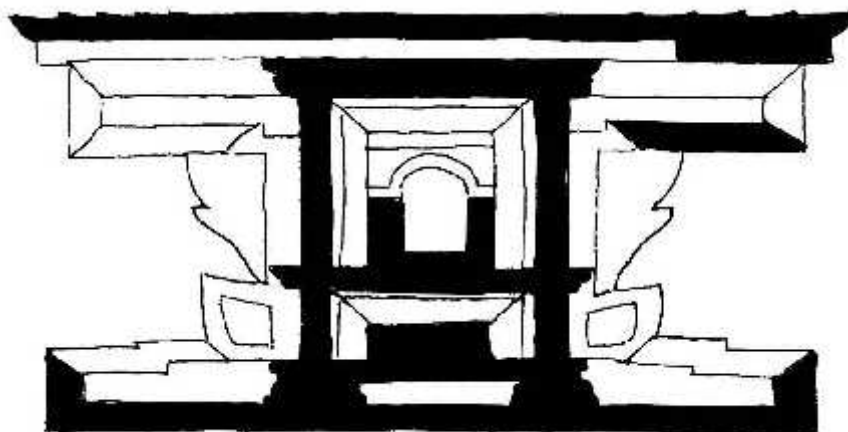

ID No.: B/K 202-WIN(A) 12

Name: Gaa Jhyaa (Side)

Monument: Pu Dega (Ground Storey)

Size: 104 X 150 cm

Quantity: 1

Material: Wood

Currently stored at: Trishul Chowk.

Remarks & Recommendations: The lost parts and unusable portions are to be recarved to make the window complete.

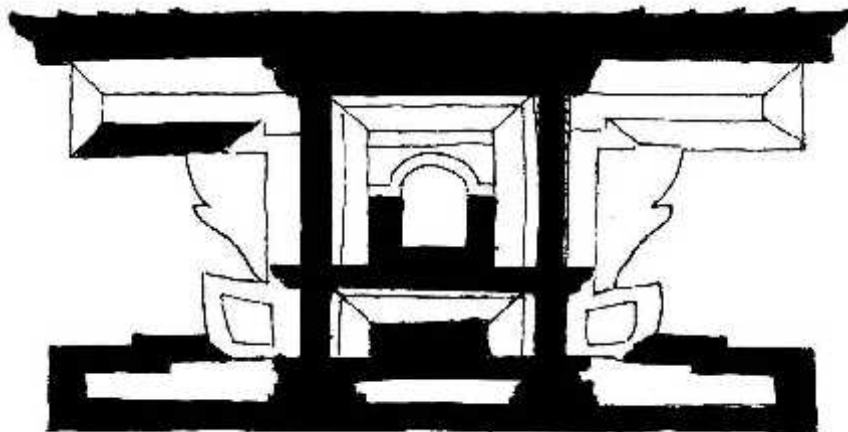

ID No.: B/K 202-WIN(A) 13

Name: Gaa Jhyaa (Side)

Monument: Pu Dega (Ground Storey)

Size: 104 X 150 cm

Quantity: 1

Material: Wood

Currently stored at: Trishul Chowk.

Remarks & Recommendations: The lost parts and unusable portions are to be recarved to make the window complete.

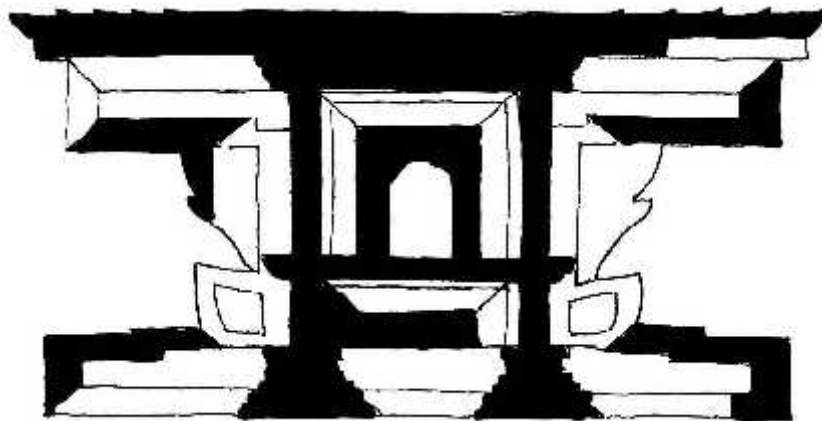

ID No.: B/K 202-WIN(A) 14

Name: Gaa Jhyaa (Side)

Monument: Pu Dega (Ground Storey)

Size: 104 X 150 cm

Quantity: 1

Material: Wood

Currently stored at: Trishul Chowk.

Remarks & Recommendations: The lost parts and unusable portions are to be recarved to make the window complete.

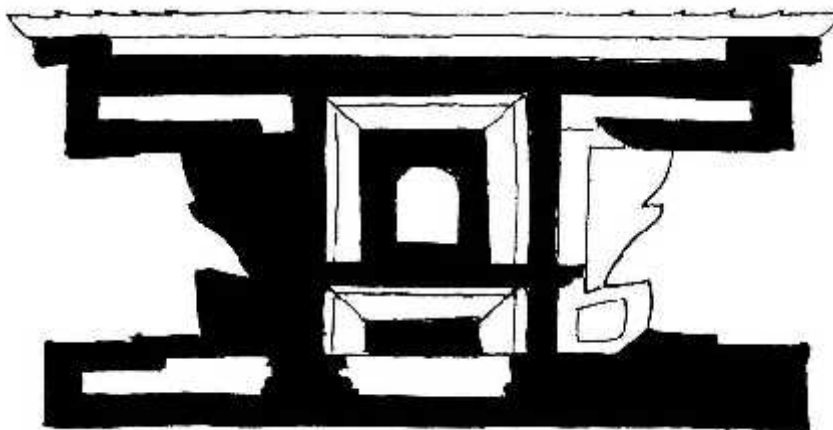

ID No.: B/K 202-WIN(A) 15

Name: Gaa Jhyaa (Side)

Monument: Pu Dega (Ground Storey)

Size: 104 X 150 cm

Quantity: 1

Material: Wood

Currently stored at: Trishul Chowk.

Remarks & Recommendations: The lost parts and unusable portions are to be recarved to make the window complete.

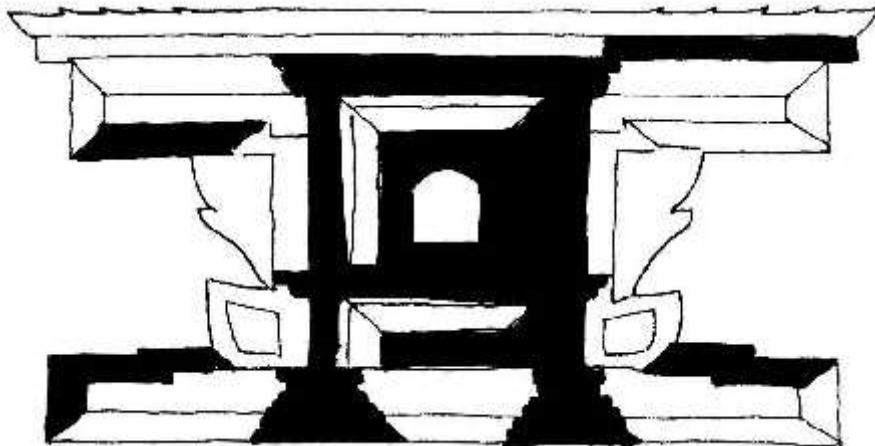

ID No.: B/K 202-WIN(A) 16

Name: Gaa Jhyaa (Middle)

Monument: Pu Dega (Ground Storey)

Size: 133 X 232 cm

Quantity: 1

Material: Wood

Currently stored at: Trishul Chowk.

Remarks & Recommendations: The lost parts and unusable portions are to be re-carved to make the window complete.

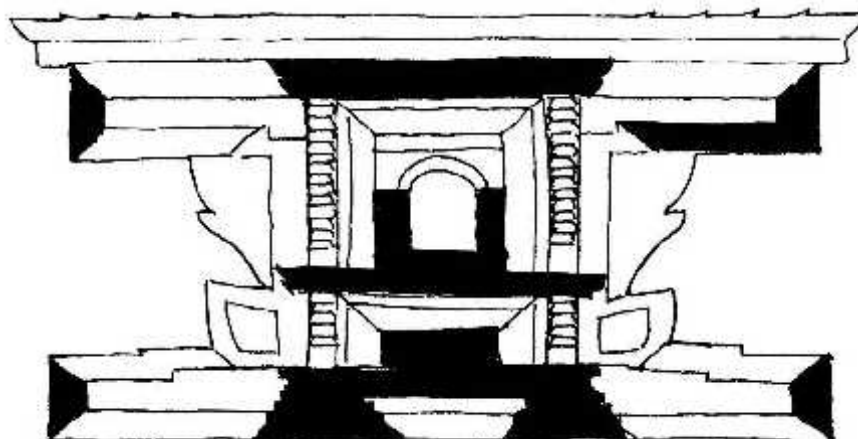

ID No.: B/K 202-WIN(A) 17

Name: Gaa Jhyaa (Middle)

Monument: Pu Dega (Ground Storey)

Size: 133 X 232 cm

Quantity: 1

Material: Wood

Currently stored at: Trishul Chowk.

Remarks & Recommendations: The lost parts and unusable portions are to be re-carved to make the window complete.

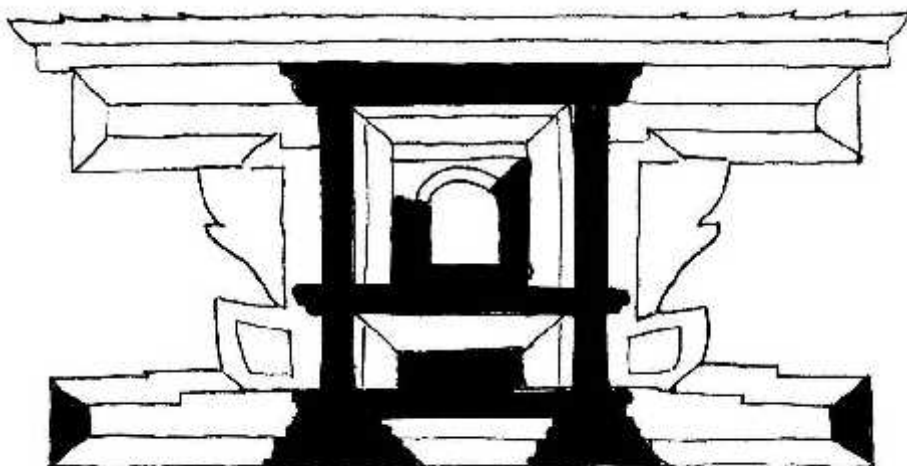

ID No.: B/K 202-WIN(A) 18

Name: Gaa Jhyaa (Middle)

Monument: Pu Dega (Ground Storey)

Size: 133 X 232 cm

Quantity: 1

Material: Wood

Currently stored at: Trishul Chowk.

Remarks & Recommendations: The lost parts and unusable portions are to be re-carved to make the window complete.

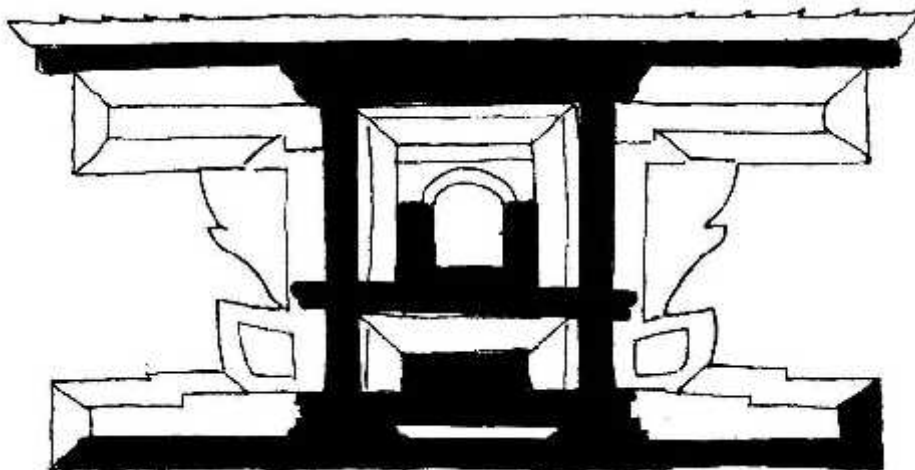

ID No.: B/K 202-WIN(A) 19

Name: Gaa Jhyaa (Middle)

Monument: Pu Dega (Ground Storey)

Size: 133 X 232 cm

Quantity: 1

Material: Wood

Currently stored at: Trishul Chowk.

Remarks & Recommendations: The lost parts and unusable portions are to be re-carved to make the window complete.

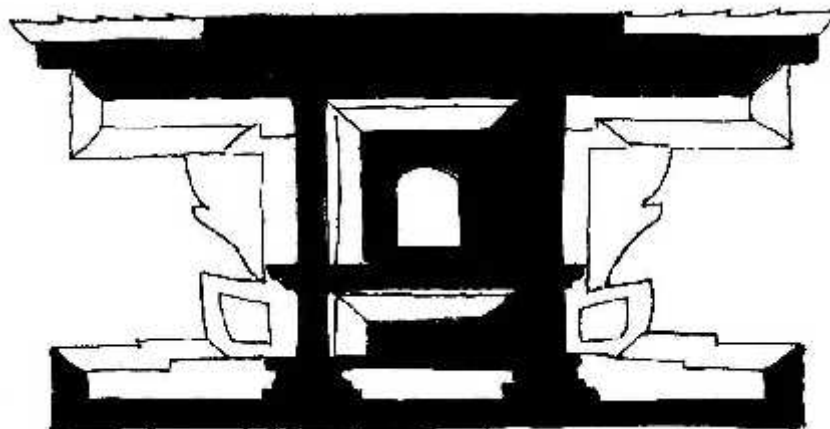

ID No.: B/K 202-WIN(B) 01

Name: Yaaku Jhya

Monument: Pu Dega

Size: 96 X 54 cm

Quantity: 1

Material: Wood

Currently stored at: Shelter 1

Remarks & Recommendations: Partially damaged.

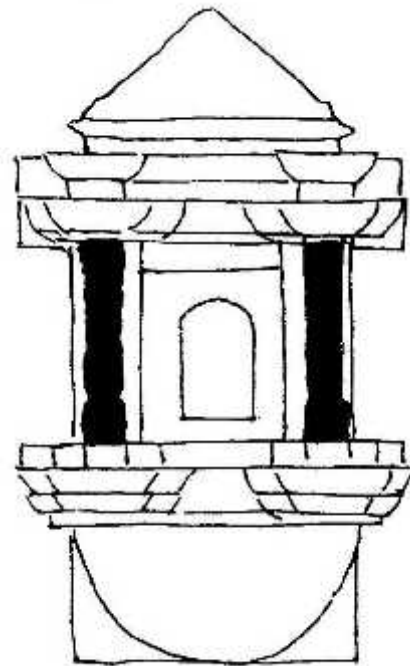

ID No.: B/K 202-WIN(B) 02

Name: Yaaku Jhya

Monument: Pu Dega

Size: 96 X 54 cm

Quantity: 1

Material: Wood

Currently stored at: Shelter 1

Remarks & Recommendations: Partially damaged

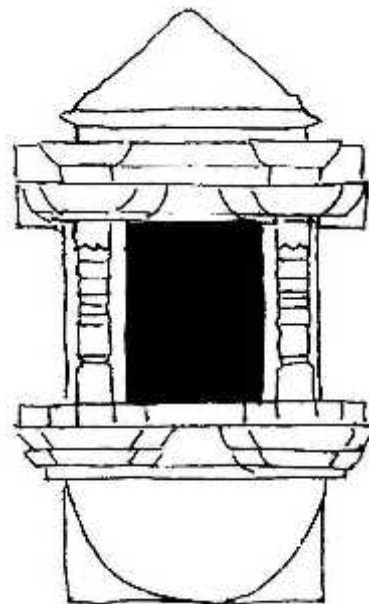

ID No.: B/K 202-WIN(B) 03

Name: Yaaku Jhya

Monument: Pu Dega

Size: 96 X 54 cm

Quantity: 1

Material: Wood

Currently stored at: Shelter 1

Remarks & Recommendations: Partially damaged

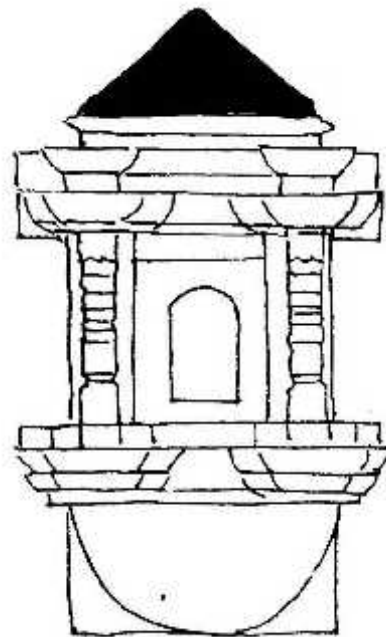

ID No.: B/K 202-WIN(B) 04

Name: Yaaku Jhya

Monument: Pu Dega

Size: 96 X 54 cm

Quantity: 1

Material: Wood

Currently stored at: Shelter 1

Remarks & Recommendations: Mostly damaged

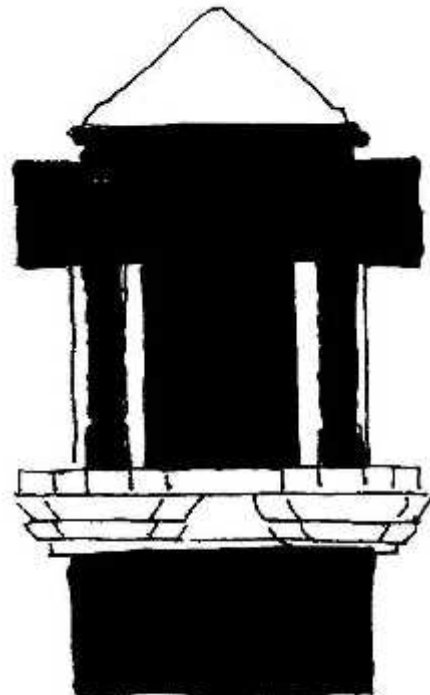

ID No.: B/K 202-WIN(B) 05

Name: Yaaku Jhya

Monument: Pu Dega

Size: 96 X 54 cm

Quantity: 1

Material: Wood

Currently stored at: Shelter 1

Remarks & Recommendations: Partially damaged

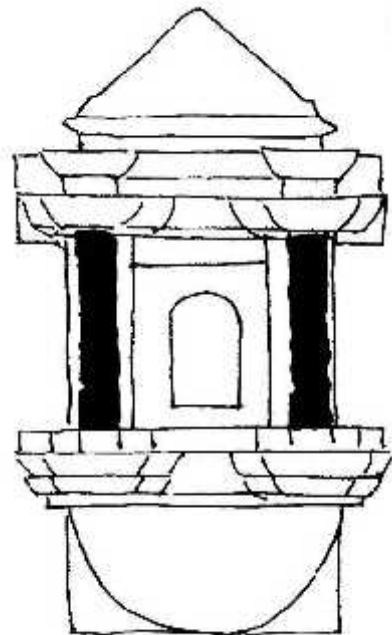

ID No.: B/K 202-WIN(B) 06

Name: Yaaku Jhya

Monument: Pu Dega

Size: 96 X 54 cm

Quantity: 1

Material: Wood

Currently stored at: Shelter 1

Remarks & Recommendations: Partially damaged

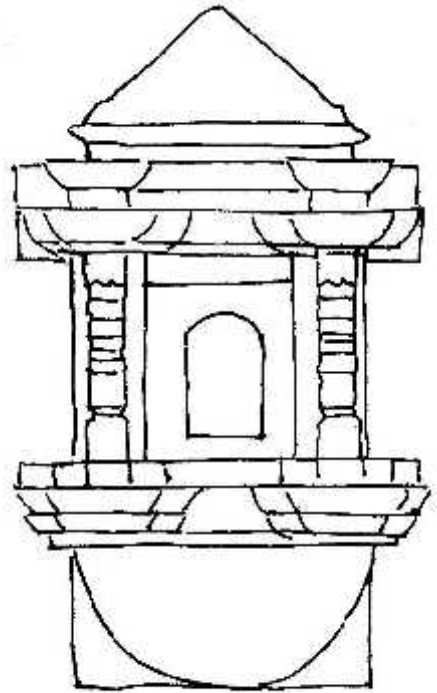

ID No.: B/K 202-WIN(B) 07

Name: Yaaku Jhya

Monument: Pu Dega

Size: 96 X 54 cm

Quantity: 1

Material: Wood

Currently stored at: Shelter 1

Remarks & Recommendations: Partially damaged

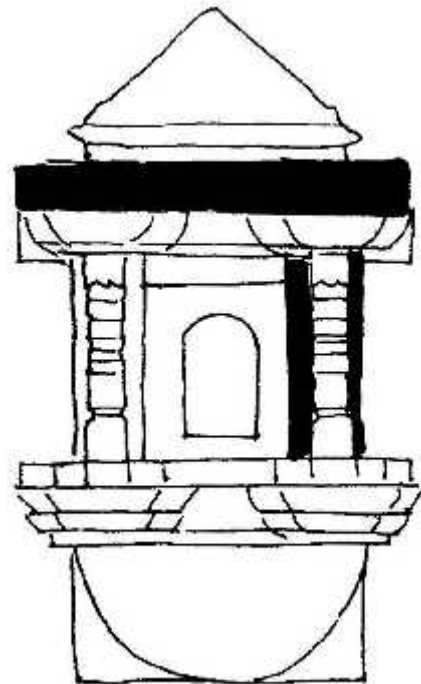

ID No.: B/K 202-WIN(B) 08

Name: Yaaku Jhya 3

Monument: Pu Dega

Size: 96 X 54 cm

Quantity: 1

Material: Wood

Currently stored at: Shelter 1

Remarks & Recommendations: Still intact

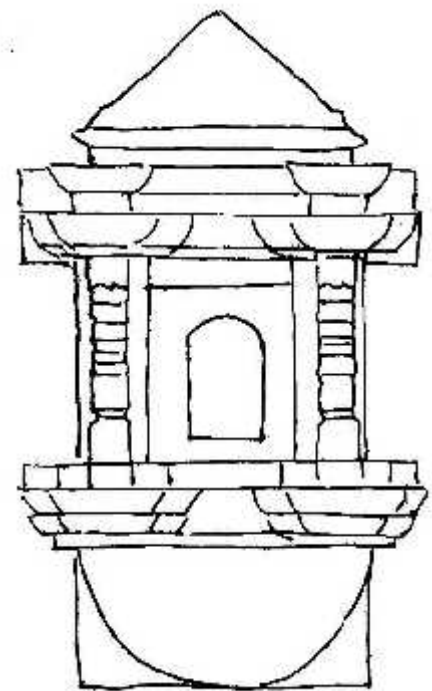

ID No.: B/K 202-WIN(C) 01

Name: False Window (Side)

Monument: Pu Dega (Middle Storey)

Size: 53 X 25cm

Quantity: 1

Material: Wood.

Currently stored at: Shelter 1

Remarks & Recommendations: Reusable.



ID No.: B/K 202-WIN(C) 02

Name: False Window (Side)

Monument: Pu Dega (Middle Floor)

Size: 53X25 cm

Quantity: 1

Material: Wood.

Currently stored at: Shelter 1

Remarks & Recommendations: Reusable.



ID No.: B/K 202-WIN(C) 03

Name: False Window (Side)

Monument: Pu Dega (Middle Floor)

Size: 53 X 25 cm

Quantity: 1

Material: Wood.

Currently stored at: Shelter 1

Remarks & Recommendations: To be repaired.



ID No.: B/K 202-WIN(C) 04

Name: False Window (Side)

Monument: Pu Dega (Middle Floor)

Size: 53 X 25 cm

Quantity: 1

Material: Wood

Currently stored at: Shelter 1

Remarks & Recommendations: Reusable.



ID No.: B/K 202-WIN(C) 05

Name: False Window (Side)

Monument: Pu Dega (Middle Floor)

Size: 53 X 25 cm

Quantity: 1

Material: Wood.

Currently stored at: Shelter 1

Remarks & Recommendations: To be repaired.



ID No.: B/K 202-WIN(C) 06

Name: False Window (Side)

Monument: Pu Dega (Middle Floor)

Size: 53 X 25 cm

Quantity: 1

Material: Wood

Currently stored at: Shelter 1

Remarks & Recommendations: Reusable.



ID No.: B/K 202-WIN(C) 07

Name: False Window (Side)

Monument: Pu Dega (Middle Floor)

Size: 53 X 25 cm

Quantity: 1

Material: Wood

Currently stored at: Shelter 1

Remarks & Recommendations: Reusable.



ID No.: B/K 202-WIN(C) 08

Name: False window (Side)

Monument: Pu Dega (Middle Floor)

Size: 53 X 25 cm

Quantity: 1

Material: Wood

Currently stored at: Shelter 1

Remarks & Recommendations: Reusable.



ID No.: B/K 202-Door 1

Name: Door

Monument: Pu Dega (Trailokya Mohan Temple)

Size: 190X315cm at the widest.

Quantity:1

Material: Wood

Currently stored at: Nasal Chowk

Remarks & Recommendation: The Tolanthaan and top piece is lost. Re-carve it and fix.(see attached drawing)

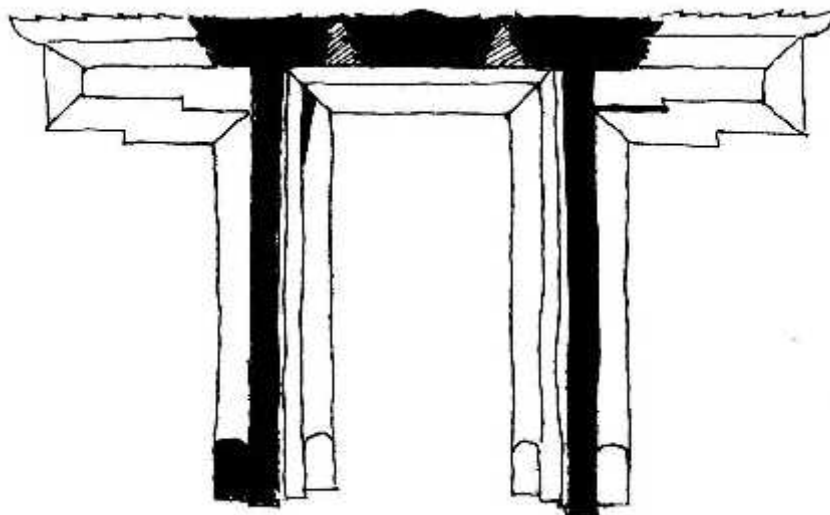

ID No.: B/K 202-Door 2

Name: Door

Monument: Pu Dega (Trailokya Mohan Temple)

Size: 190X315cm at the widest.

Quantity: 1

Material: Wood

Currently stored at: Trishul Chowk

Remarks & Recommendation: Left *toanthaan* is broken and right one is lost.

Remake them and fix them.(see the attached drawing)

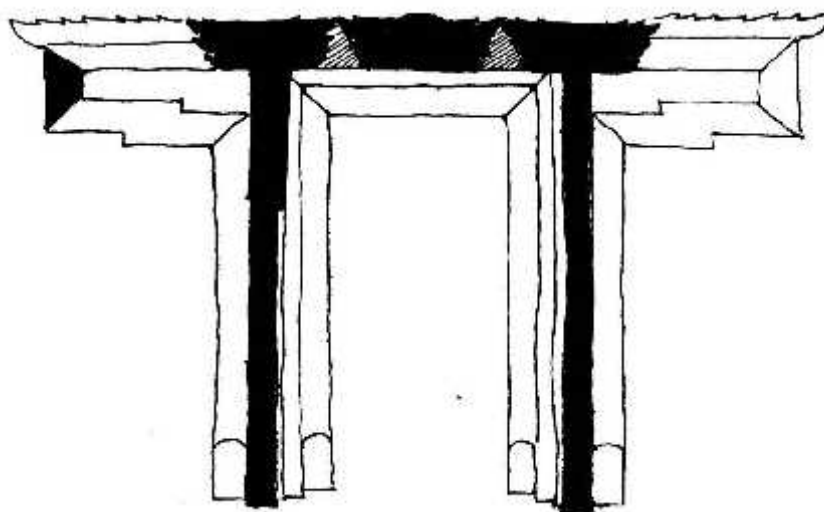

ID No.: B/K 202-Door 3

Name: Door

Monument: Pu Dega (Trailokya Mohan Temple)

Size: 190 X 315cm at the widest.

Quantity: 1

Material: Wood

Currently stored at: Trishul Chowk

Remarks & Recommendation: Lost portions are shown in the drawing. (Please refer to that)

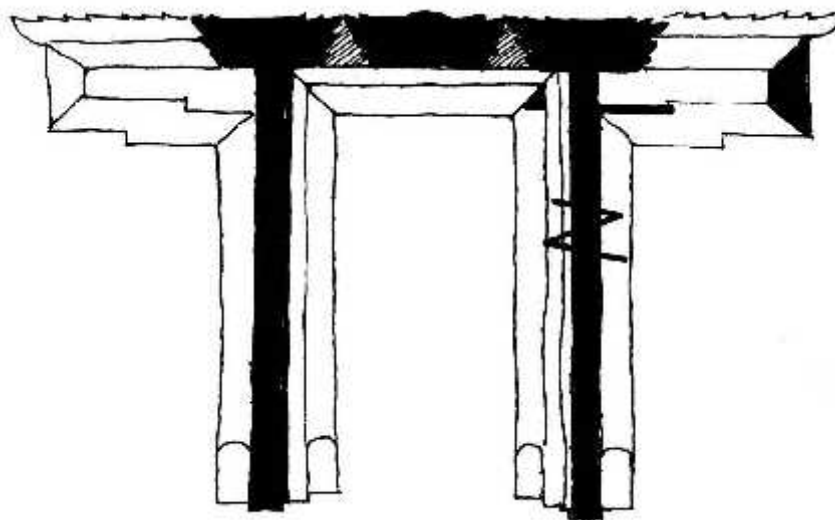

ID No.: : B/K 202-Door 4

Name: Door

Monument: Pu Dega (Trailokya Mohan Temple)

Size: 190X315cm at the widest

Quantity: 1

Material: Wood

Currently stored at: Trishul Chowk

Remarks & Recommendation: The lost parts are shown in the drawing attached with.

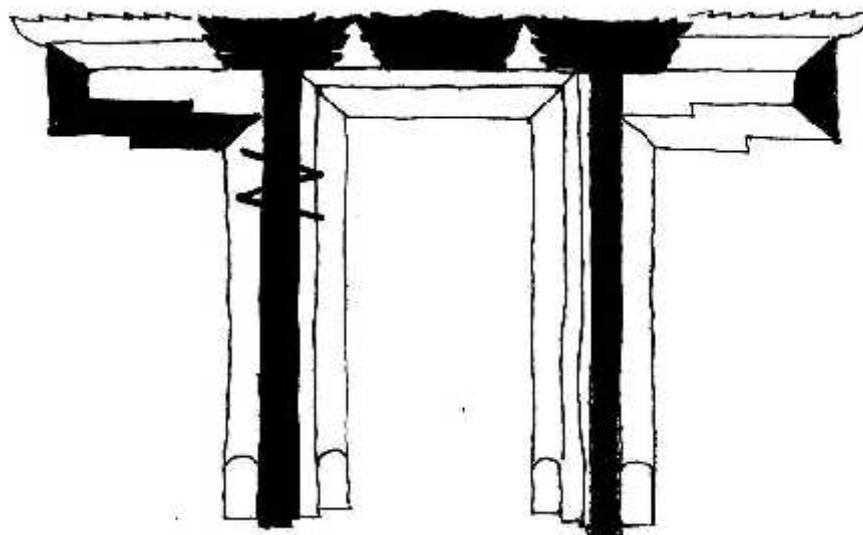

ID No.: B/K 202-Pillar

Name: Tham (Pillar)

Monument: Pu Dega (Trailokya Mohan Temple)

Size: 190 X 24 X 24 cm

Quantity: 20

Material: Wood

Currently stored at: Shelter 2

Remarks & Recommendation: Make the tenon and fix. And then can be reused.



ID No.: B/K202-Meth

Name: Meth

Monument: Pun Dega

Size: 140 X 20 X 25 cm (Full Meth), 115 X 20 X 20 cm (Half Meth)

Quantity: Full Meth -16 nos., Half Meth – 6 nos. complete/rest broken and lost.

Material: Wood

Currently stored at: Shelter 1

Remarks & Recommendation: Remake the broken pieces taking reference of the complete ones. (In actual condition, there should be 16 complete meths and 16 half meths)



ID No.: B/K202-CH

Name: Chakulaan

Monument: Pun Dega

Size: 40 X 40 cm

Quantity: 20 (almost all broken)

Material: Wood

Currently stored at: Shelter 1



Remarks & Recommendation: Needs extensive repair to be reused. Rebuilding new ones is recommended or stitch them using new timber locks.

ID No.: B/K202-Dh

Name: Dhalinkhwa

Monument: Pun Dega

Size: Varies

Quantity: more than 150

Material: Wood

Currently stored at: Shelter 1

Remarks & Recommendation: Almost all that are recovered are in good condition. Some may need repair.



ID No.: B/K 202-ICON(S) 01

Name: Baikuntha Vishnu

Monument: Pu Dega (Trailokya Mohan
Temple)

Size: 130 X 80 cm

Quantity: 1

Material: Stone

Currently stored at: Still in situ.

Remarks & Recommendation: To be treated
carefully while carrying out renovation
work.



.

MAJU DEGA (B/K-191)

01. Struts

02. Strut Fragment

03. Kunsala

04. Windows

05. Doors

06. Door Panel

07. Pillar

08. Meth

09. Chakulaan

10. Dhalinkhwa

11. Stone Icon

ID No.:B/K191-TDL 01

Name: Divine couple.

Monument: Maju Dega

Size: 198 X 35 X 14 cm

Quantity: 1

Currently stored at: Shelter-1 (East of Taleju Temple)

Material: Wood.

Remarks & Recommendation: Vertically cracked from
bottom to middle portion. All hands are gone off.



ID No.: B/K191-TDL 02

Name: Divine Couple.

Monument: Maju Dega

Size: 195 X 36 X 14cm

Quantity: 1

Currently stored at: Shelter-1 (East of Taleju Temple)

Material: Wood.

Remarks & Recommendation: Vertically broken into half and also rotten due to the water percolation. Hands and legs are also gone. Not advisable to reuse. Could be kept in the museum. Even if reused back support must be given.



ID No. : B/K191-TDL 03

Name: Divine couple in embrace. (*Yaksha Shiva*)

Monument: Maju Dega

Size: 215 X 30 X 15cm

Quantity : 1

Currently stored at: Shelter-1 (East of Taleju Temple)

Material: Wood.

Remarks & Recommendation: Vertically cracked till half down and slightly insect eaten. Both the bent legs of Male and female figures are broken off including all hands. Though little rotten could be reused with supports from both sides.



ID No.: B/K191-TDL 04

Name: Strut having the figure of *Birabhadra*—aspect of Shiva (Amorous divine Couple).

Monument: Maju Dega

Size: 190 X 35 X 16cm.

Quantity: 1

Currently stored at: Shelter-1 (East of Taleju Temple)

Material: Wood.

Remarks & Recommendation: *Betal* figure is rotten away due to the water percolation. Upper one third portion is vertically cracked. All ten hands are gone except one right hand of female figure that embraces the lord. Can be reused with two supports and strengthening from top. Slight wash is recommended.



ID No. : B/K191-TDL 05

Name: Divine couple in amorous embrace.

Monument: Maju Dega

Size: 195 X 36 X 13cm

Quantity: 1

Currently stored at: Shelter 1

Material: Wood.

Remarks & Recommendation: Relatively in good condition except climatic erosion. Little crack on top. Could be reused by providing two supports.



ID No. : B/K191-TDL 06

Name: Amorous divine couple.

Monument: Maju Dega

Size: 190 X 34 X 15cm

Quantity: 1

Currently stored at: Shelter 1

Material: Wood.

Remarks & Recommendation: Middle portion is broken off. Percolation of rain caused the shoulder portion rotten. Still the condition is reusable with supports from both sides. Provide the hands and attributes and can be reused with support in both sides.



ID No. : B/K191-TDL 07

Name: Amorous divine couple.

Monument: Maju Dega

Size: 215 X 30 X 15cm

Quantity: 1

Currently stored at: Shelter 1

Material: Wood.

Remarks & Recommendation: Except few cracks in overall is in the state of reusable. The right leg and hands of male figure and left hand of female in pedestal is broken off during earthquake. One right feet of Devi is gone. Both the heads of the bull is gone. Still can be reused with supports from both sides.



ID No. : B/K191-TDL 08

Name: Divine couple in embrace.

Monument: Maju Dega

Size: 190 X 33 X 13cm.

Quantity: 1

Currently stored at: Shelter 1

Material: Wood.

Remarks & Recommendation: Middle portion is rotten away due to the rain percolation. Small vertical crack on top. All hands and one foot of the God is broken off. (God is three headed.) Though rotten in middle part, can be reused with support on both sides of the struts.



ID No. : B/K191-TDL 09

Name: Divine couple.

Monument: Maju Dega

Size: 190 X 35 X 15cm

Quantity: 1

Currently stored at: Shelter 1

Material: Wood.

Remarks & Recommendation: Vertically cracked from bottom upto half height. Wood condition is still good. All hands of both figures are gone. Right breast of the Goddess is broken off. Can be reused with two supports on both sides of the strut.



ID No. : B/K191-TDL 10

Name: Divine couple.

Monument: Maju Dega

Size: (205+4.5) X 31 X 14cm

Quantity: 1

Currently stored at: Shelter 1

Material: Wood.

Remarks & Recommendation: Except climatic erosion, the condition of the wood is intact. Hands of the main figures are gone. Could be reused with addition of the hands. The eros figure is remarkable in the sense of moment the man is grabbing the moment while the woman is flaking the wood with her axe. Is not it surprising?



ID No. : B/K191-TDL 11

Name: Bhairava and Matrika.

Monument: Maju Dega

Size: 176 X 21 X 13cm

Quantity: 1

Currently stored at: Shelter 1

Material: Wood.

Remarks & Recommendation: Half the right portion is broken off and both feet of Bhairava are gone. There is a vertical crack front half of the *vahana* is rotten due to rain porcolation. Still could be reused with supports from three sides. Recommended back support and side support.



ID No. : B/K191-TDL 12

Name: Divine Couple of Bhairava and Matrika.

Monument: Maju Dega

Size: 175 X 31 X 12cm

Quantity: 1

Currently stored at: Shelter 1

Material: Wood.

Remarks & Recommendation: All hands are gone. Half below is cracked vertically. Interesting pedestal figure of Mridangavadaka is cracked badly. Half the lower portion is cracked vertically. All hands are gone.



ID No. : B/K191-TDL 13

Name: Divine figure of a river God and Goddess.

Monument: Maju Dega

Size: 215 X 33 X 15cm

Quantity: 1

Currently stored at: Shelter 1

Material: Wood.

Remarks & Recommendation: Vertically cracked at the middle from top to bottom except at central figure. Should be tightened from the back and given the two supporting pillars. An unusual depiction of eroticism- a child is licking the private part of a woman.



ID No. : B/K191-TDL 14

Name: Divine figure of Bhairav and Matrika.

Monument: Maju Dega

Size: 215 X 28 X 15cm

Quantity: 1

Currently stored at: Shelter 1

Material: Wooden.

Remarks & Recommendation: Top portion is slightly cracked. Hands of the main figures are gone. All hands are gone. Main male figure is rotten due to rain porcolation. Having a nice eros figure at the pedestal. Could be reused with support on both sides. The second strut of second storey from the left in the East Façade.



ID No. : B/K191-TDL 15

Name: Seven Headed figure of Bhairava with his Sakti.

Monument: Maju Dega

Size: 195 X 36 X 17cm.

Quantity: 1

Currently stored at: Shelter 1

Material: Wood.

Remarks & Recommendation: Half cracked to the middle from top. Still could be reused by support from the back and support in left and right. The eros figure in the pedestal is nicely depicted- a woman enticing the man pulling his hand.



ID No. : B/K191-TDL 16

Name: Divine couple standing on a couple of fishes.

Monument: Maju Dega

Size: 217 X 37 X 15cm

Quantity: 1

Currently stored at: Shelter 1

Material: Wood

Remarks & Recommendation: All hands are gone. A crack going down slightly but still could be used with support from the back, left and right. A figure in pedestal is unusual in eros depiction where a man (or a eunuch) lying on the back with unusually bigger Size of linga. Sixth strut from the left in the first storey in south façade.



ID No. : B/K191-TDL 17

Name: Divine couple of Bhairav and Vaishnavi.

Monument: Maju Dega

Size: 170 X 32 X 15cm

Quantity: 1

Currently stored at: Shelter 1

Material: Wood

Remarks & Recommendation: All hands are gone and front portion of the entire figure is eroded due to time elapsed. Except the left leg of Matrika other legs and hands are gone. Even the left hand of the figure in pedestal is eroded off. The Lotus flower is almost gone. Though the strut is badly eroded, it could still be reused with support in two sides in the left and right.



ID No. : B/K191-TDL 18

Name: Bhairav with Maheswari

Monument: Maju Dega

Size: 175 X 23 X 18cm

Quantity: 1

Currently stored at: Shelter 1

Material: Wood

Remarks & Recommendation: Half from the middle is cracked to the bottom. Both hands are gone. Back support is necessary and also the side supports.



ID No. : B/K191-TDL 19

Name: Bhairav with his consort Kaumari.

Monument: Maju Dega

Size: 175 X 28 X 12cm

Quantity: 1

Currently stored at: Shelter 1

Material: Wood

Remarks & Recommendation: Lower portion is more eroded due to the climatic commotion. Half the strut is vertically cracked from the bottom to middle portion. All four hands are broken off.



ID No. : B/K191-TDL 20

Name: Divine couple- Siva with Yamuna.

Monument: Maju Dega

Size: 195 X 33 X 15cm

Quantity: 1

Currently stored at: Shelter 1

Material: Wood

Remarks & Recommendation: Cracked vertically from top to the middle portion. Middle portion is rotten partially due to the water porculation. All hands are gone. Should be re-strengthen from back and give two supporting pillars if reused. Erotic figure on pedestal portion.



ID No. : B/K191-TDL 21

Name: Bhairava with Chamunda.

Monument: Maju Dega

Size: 175 X 28 X 13cm

Quantity: 1

Currently stored at: Shelter 1

Material: Wood

Remarks & Recommendation: With supports in both sides the strut can be reused. Too much time eroded.



ID No. : B/K191-TDL 22

Name: Shiva Shakti.

Monument: Maju Dega

Size: 195 X 31 X 15cm

Quantity: 1

Currently stored at: Shelter 1

Material: Wood.

Remarks & Recommendation: Badly rusted due to the
water percolation. The weight bearing capacity is gone.

Not reusable.



ID No. : B/K191-TDL 23

Name: Shiva Shakti

Monument: Maju Dega

Size: 210 X 30 X 20cm

Quantity: 1

Currently stored at: Shelter 1

Material: Wood.

Remarks & Recommendation: Give the support on both sides and reuse.



ID No. : B/K191-TDL 24

Name: Samshan Bhairav?

Monument: Maju Dega

Size: 208 X 31 X 13cm

Quantity: 1

Currently stored at: Shelter 1

Material: Wood.

Remarks & Recommendation: Cracked from top to bottom at the middle. Check the strength and reuse if possible.



ID No. : B/K191-TDL 25

Name: A form of Shiva Parvati

Monument: Maju Dega

Size: 217 X 28 X 16cm

Quantity: 1

Currently stored at: Shelter 1

Material: Wood.

Remarks & Recommendation: Give the support on both sides and reuse.



ID No. : B/K191-TDL 26

Name: A form of Shiva Parvati

Monument: Maju Dega

Size: 216 X 31 X 16cm

Quantity: 1

Currently stored at: Shelter 1

Material: Wood.

Remarks & Recommendation: Give the support on both sides and reuse.



ID No. : B/K191-TDL 27

Name: Gangadhar Shiva

Monument: Maju Dega

Size: 188 X 33 X 15cm

Quantity: 1

Currently stored at: Shelter 1

Material: Wood.

Remarks & Recommendation: Refitted but not usable.

Keep in exhibition for educational purpose.



ID No. : B/K191-TDL 28

Name: A form of Shiva Parvati

Monument: Maju Dega

Size : 210 X 31 X 14cm

Quantity :1

Currently stored at: Shelter 1

Material: Wood.

Remarks & Recommendation: Refitted but not usable.

Keep in exhibition for educational purpose.



ID No.: B/K191-TDL 29

Name: A form of Shiva Parvati

Monument: Maju Dega

Size: 196 X 35 X 15cm

Quantity:1

Currently stored at: Shelter 1

Material: Wood.

Remarks & Recommendation: Refitted but not usable.

Keep in exhibition for educational purpose.



ID No.: B/K191-TDL 30

Name: A form of Shiva Parvati

Monument: Maju Dega

Size: 203 X 28 X 15cm

Quantity:1

Currently stored at: Shelter 1

Material: Wood.

Remarks & Recommendation: Refitted but not
usable. Keep in exhibition for educational
purpose.



ID No.: B/K191-TDL 31

Name: A form of Shiva Parvati

Monument: Maju Dega

Size: 206 X 30 X 14 cm

Quantity:1

Currently stored at: Shelter 1

Material: Wood

Remarks & Recommendation: Refitted but not
usable. Keep in exhibition for educational purpose.



ID No.: B/K191-TDL 32

Name: A form of Shiva Parvati

Monument: Maju Dega

Size: 190 X 32 X 18cm

Quantity:1

Currently stored at: Shelter 1

Material: Wood

Remarks & Recommendation: Give the support
on both sides and reuse.



ID No.: B/K191-TDL 33

Name. : A form of Shiva Parvati

Monument: Maju Dega

Size: 190 X 30 X 18 cm

Quantity:1

Currently stored at: Shelter 1

Material:

Remarks & Recommendation: Give the support on
both sides and reuse.



ID No.: B/K191-TDL(Fr) 01

Name: Strut piece.

Monument: Maju Degah

Size: 60 X 15 X 13 cm

Quantity: 1

Currently stored at: Shelter 1

Material: Wood

Remarks & Recommendation: Not reusable.

Take its reference for remaking. Keep in
exhibition for educational purpose.



ID No.: B/K191-TDL(Fr) 02

Name:

Monument: Maju Dega

Size: 120 X 30 X 15 cm

Quantity: 1

Currently stored at: Shelter 1

Material: Wood

Remarks & Recommendation: Not reusable.
Take its reference for remaking. Keep in
exhibition for educational purpose.



ID No.: B/K191-TDL(Fr) 03

Name:

Monument: Maju Dega

Size: 125 X 30 X15 cm

Quantity: 1

Currently stored at: Shelter 1

Material: Wood

Remarks & Recommendation: Not reusable. Take its reference for remaking. Keep in exhibition for educational purpose.



ID No.: B/K191-TDL(Fr) 04

Name:

Monument: Maju Dega

Size: 90 X 30 X 15 cm

Quantity: 1

Currently stored at: Shelter 1

Material: Wood

Remarks & Recommendation: Not
reusable. Take its reference for remaking.
Keep in exhibition for educational purpose.



ID No.: B/K191-TDL(Fr) 05

Name:

Monument: Maju Dega

Size: 85 X 30 X 15 cm

Quantity: 1

Currently stored at: Shelter 1

Material: Wood

Remarks & Recommendation: Not reusable. Take its reference for remaking. Keep in exhibition for educational purpose.



ID No.: B/K191-TDL(Fr) 06

Name:

Monument: Maju Dega

Size: 80 X 30 X 15 cm

Quantity: 1

Currently stored at: Shelter 1

Material: Wood

Remarks & Recommendation: Not reusable. Take its reference for remaking. Keep in exhibition for educational purpose.



ID No.: B/K191-TDL(Fr) 07

Name:

Monument: Maju Dega

Size: 100 X 35 X 15 cm

Quantity: 1

Currently stored at: Shelter 1

Material: Wood

Remarks & Recommendation: Not reusable. Take its reference for remaking. Keep in exhibition for educational purpose.



ID No.: B/K191-TDL(Fr) 08

Name:

Monument: Maju Dega

Size: 170 X 15 X 10 cm

Quantity: 1

Currently stored at: Shelter 1

Material: Wood

Remarks & Recommendation: Not reusable.

Take its reference for remaking. Keep in
exhibition for educational purpose.



ID No.: B/K191-TDL(Fr) 09

Name:

Monument: Maju Dega

Size: 58 X 16 X 13 cm

Quantity: 1

Currently stored at: Shelter 1

Material: Wood

Remarks & Recommendation: Not reusable. Take its reference for remaking. Keep in exhibition for educational purpose.



ID No.: B/K191-TDL(Fr) 10

Name:

Monument: Maju Dega

Size: 60 X 13 X 12 cm

Quantity: 1

Currently stored at: Shelter 1

Material: Wood

Remarks & Recommendation: Not reusable.
Take its reference for remaking. Keep in
exhibition for educational purpose.



ID No.: B/K191-TDL(Fr) 11

Name:

Monument: Maju Dega

Size: 120 X 16 X 16 cm

Quantity: 1

Currently stored at: Shelter 1

Material: Wood

Remarks & Recommendation: Not reusable. Take its reference for remaking. Keep in exhibition for educational purpose.



ID No.: B/K191-TDL(Fr) 12

Name:

Monument: Maju Dega

Size: 125 X 30 X 15 cm

Quantity: 1

Currently stored at: Shelter 1

Material: Wood

Remarks & Recommendation: Not reusable. Take its reference for remaking. Keep in exhibition for educational purpose.



ID No.: B/K191-TDL(Fr) 13

Name:

Monument: Maju Dega

Size: 125 X 15 X 15 cm

Quantity: 1

Currently stored at: Shelter 1

Material: Wood

Remarks & Recommendation: Not
reusable. Take its reference for remaking.
Keep in exhibition for educational purpose.



ID No.: B/K191-TDL(Fr) 14

Name:

Monument: Maju Dega

Size: 95 X 20 X 15 cm

Quantity: 1

Currently stored at: Shelter 1

Material: Wood

Remarks & Recommendation: Not reusable.
Take its reference for remaking. Keep in
exhibition for educational purpose.



ID No.: B/K191-TDL(Fr) 15

Name:

Monument: Maju Dega

Size: 60 X 35 X 15 cm

Quantity: 1

Currently stored at: Shelter 1

Material: Wood

Remarks & Recommendation:

Not reusable. Take its reference for remaking. Keep in exhibition for educational purpose.



ID No.: B/K191-TDL(Fr) 16

Name:

Monument: Maju Dega

Size: 85 X 25 X 15 cm

Quantity: 1

Material: Wood

Remarks & Recommendation: Not reusable. Take its reference for remaking. Keep in exhibition for educational purpose.



ID No.: B/K191-TDL(Fr) 17

Name:

Monument: Maju Dega

Size: 80 X 30 X 13 cm

Quantity: 1

Currently stored at: Shelter 1

Material: Wood

Remarks & Recommendation: Not reusable. Take its reference for remaking. Keep in exhibition for educational purpose.



ID No.: B/K191-TDL(Fr) 18

Name:

Monument: Maju Dega

Size: 33 X 27 X 18 cm

Quantity: 1

Currently stored at: Shelter 1

Material: Wood

Remarks & Recommendation: Not reusable. Take its reference for remaking. Keep in exhibition for educational purpose.



ID No.: B/K191-TDL(Fr) 19

Name:

Monument: Maju Dega

Size: 75 X 28 X 13 cm

Quantity: 1

Currently stored at: Shelter 1

Material: Wood

Remarks & Recommendation: Not reusable. Take its reference for remaking. Keep in exhibition for educational purpose.



ID No.: B/K191-TDL(Fr) 20

Name:

Monument: Maju Dega

Size: 32 X 9 X 15 cm

Quantity: 1

Currently stored at: Shelter 1

Material: Wood

Remarks & Recommendation: Not reusable. Take its reference for remaking. Keep in exhibition for educational purpose.



ID No.: B/K191-TDL(Fr) 21

Name:

Monument: Maju Dega

Size: 60 X 15 X 16 cm

Quantity: 1

Currently stored at: Shelter 1

Material: Wood

Remarks & Recommendation: Not reusable. Take its reference for remaking. Keep in exhibition for educational purpose.



ID No.: B/K191-TDL(Fr) 22

Name:

Monument: Maju Dega

Size: 65 X 15 X 14 cm

Quantity: 1

Currently stored at: Shelter 1

Material: Wood

Remarks & Recommendation: Not reusable. Take its reference for remaking. Keep in exhibition for educational purpose.



ID No.: B/K191-TDL(Fr) 23

Name:

Monument: Maju Dega

Size: 60 X 10 X 14 cm

Quantity: 1

Currently stored at: Shelter 1

Material: Wood

Remarks & Recommendation: Not reusable.
Take its reference for remaking. Keep in
exhibition for educational purpose.



ID No.: B/K191-TDL(Fr) 24

Name. :

Monument: Maju Dega

Size: 127 X 35 X 15 cm

Quantity:1

Currently stored at: Shelter 1 Shelter 1

Material: Wood

Remarks & Recommendation: Not reusable. Take its reference for remaking. Keep in exhibition for educational purpose.



ID No.: B/K191-TDL(Fr) 25

Name. :

Monument: Maju Dega

Size: 186 X 29 X 15 cm

Quantity: 1

Currently stored at: Shelter 1 Shelter 1

Material: Wood

Remarks & Recommendation: Not reusable.

Take its reference for remaking. Keep in
exhibition for educational purpose.



ID No.: B/K191-TDL(Fr) 26

Name. :

Monument: Maju Dega

Size: 165 X 25 X 13 cm

Quantity:1

Currently stored at: Shelter 1 Shelter 1

Material: Wood

Remarks & Recommendation: Not reusable.

Take its reference for remaking. Keep in
exhibition for educational purpose.



ID No.: B/K191-TDL(Fr) 27

Name. :

Monument: Maju Dega

Size: ?

Quantity:1

Currently stored at: Shelter 1 Shelter 1

Material: Wood

Remarks & Recommendation: Not reusable.

Take its reference for remaking. Keep in
exhibition for educational purpose.



ID No.: B/K191-TDL(Fr) 28

Name. :

Monument: Maju Dega

Size: 185 X 29 X 13 cm

Quantity: 1

Currently stored at: Shelter 1 Shelter 1

Material: Wood

Remarks & Recommendation: Not reusable.

Take its reference for remaking. Keep in
exhibition for educational purpose.



ID No.: B/K191-TDL(Fr) 29

Name. :

Monument: Maju Dega

Size: 130 X 30 X 15cm

Quantity: 1

Currently stored at: Shelter 1 Shelter 1

Material: Wood

Remarks & Recommendation: Not reusable.

Take its reference for remaking. Keep in
exhibition for educational purpose.



ID No.: B/K191-TDL(Fr) 30

Name. :

Monument: Maju Dega

Size: 124X 30 X 13 cm

Quantity:1

Currently stored at: Shelter 1 Shelter 1

Material: Wood

Remarks & Recommendation: Not
reusable. Take its reference for remaking.
Keep in exhibition for educational purpose.



ID No.: B/K191-K01

Name: Corner Strut (Kunsala)

Monument. :Majudega (Bottom roof)

Size. : 254 x 20 x 28 cm

Quantity: 1

Currently stored at: Shelter 1

Material. : Wood

Remarks & Recommendation. : Nearly perfect, could be reused The cracked part behind head and chest is found tightened with knot bolt. Therefore it is sound and strong enough to reuse after giving a wash or cleaning.



ID No.: B/K191-K02

Name: Kunsala (Corner Strut)

Monument. :Majudega (bottom roof)

Size. : 249 X 23 X 28 cm

Quantity: 1

Currently stored at: Shelter 1

Material. : wood

Remarks & Recommendation. : Nearly perfect, could be reused The cracked part behind head a chest is found tightened with knot bolt. Therefore it is sound and strong enough to reuse after giving a wash or cleaning.



ID No.: B/K191-K03

Name: Kunsala (Corner Strut)

Monument: Majudega

Size: 249 X 23 X 25 cm

Qty: 1

Currently stored at: Shelter 1

Material: wood

Remarks & Recommendation: Almost as good as before except the time lapse. could be reused after giving cleaning or wash and some bits of strengthening.



ID No.: B/K191-K04

Name: Kunsala (Corner Strut)

Monument: Majudega (bottom roof)

Size. : 251 X 25 X 25 cm

Quantity: 1

Currently stored at: Shelter 1

Material: Wood

Remarks & Recommendation: Cracked
in middle vertically but tops and bottom
are still intact. tightening horizontally
with some still bars or threads can bring
strength and is reusable.



ID No.: B/K191-K05

Name: Kunsala (Corner Strut)

Monument: Majudega (middle roof)

Size: 239 X 25 X 25 cm

Quantity: 1

Currently stored at: Shelter 1

Material: wood

Remarks & Recommendation: Except one body of lion couple cracked, rest is intact. Tightening at the neck point horizontally will bring the strength to reuse the strut. Rest is intact.



ID No.: B/K191-K06

Name: Kunsala (Corner Strut)

Monument: Majudega (Middle Roof)

Size: 244 X 25 X 25 cm

Quantity: 1

Currently stored at: Shelter 1

Material: Wood

Remarks & Recommendation: A fissure is noticed vertically from top to bottom but not deep. Vertical fissure is noticed from top to bottom but still strong enough to reuse. But advisable to tighten vertically with some still bar or strings in order not to be splitted more due to the weight factor.



ID No.: B/K191-K07

Name: Kunsala (Corner Strut)

Monument: Majudega (bottom roof)

Size: 251 X 23 X 25 cm

Quantity: 1

Currently stored at: Shelter 1

Material: Wood

Remarks & Recommendation: Broken lower part and flaked off. Useful only for museum piece and as teaching aids. The lion parts are still gone. Make new one.



ID No.: B/K191-K08

Name: Kunsala (Corner Strut)

Monument: Majudega (Bottom Roof)

Size: 206 X 21 X 25 cm

Quantity: 1

Currently stored at: Shelter 1

Material: Wood

Remarks & Recommendation: Cracked from the head to his groin of the lion and head to his portion is rotten due to rain percolation. Also one third part on the bottom cracked. Lost is the strength, therefore good only for a museum piece. Due to breakage and cracks all around, the piece is not advisable to reuse though looks nearly complete. Good only for the Exhibition in the museum and teaching schools as a module.



ID No.: B/K191-K09

Name: Kunsala (Corner Strut)

Monument: Majudega

Size: 204 X 20 X 25 cm

Quantity: 1

Currently stored at: Shelter 1

Material: Wood

Remarks & Recommendation: Right side portion is cracked but does not go through. Rest is intact. It is advisable to tighten horizontally by steel bars or strings and reuse again.



ID No.: B/K191-K10

Name: Name: Kunsala (Corner Strut)

Monument: Majudega

Size: 217 X 20 X 20 cm

Quantity: 1

Currently stored at: Shelter 1

Material: Wood

Remarks & Recommendation: Can be reused
after cleaning.



ID No.: B/K191-K11

Name: Name: Kunsala (Corner
Strut)

Monument: Majudega

Size: 207 X 22 X 26 cm

Quantity: 1

Currently stored at: Shelter 1

Material: Wood

Remarks & Recommendation:
Strength with nut and bolt. Then
wash and reuse.



ID No.: B/K191-WIN(A) 01

Name: Ga Jhya

Monument: Maju Dega (Middle Storey)

Size: 170 X 288 cm at the widest.

Quantity: 1

Material: Wood

Currently stored at: Trishul Chowk

Remarks & Recommendation: The lost parts and unusable portions are to be recarved to make the window complete.

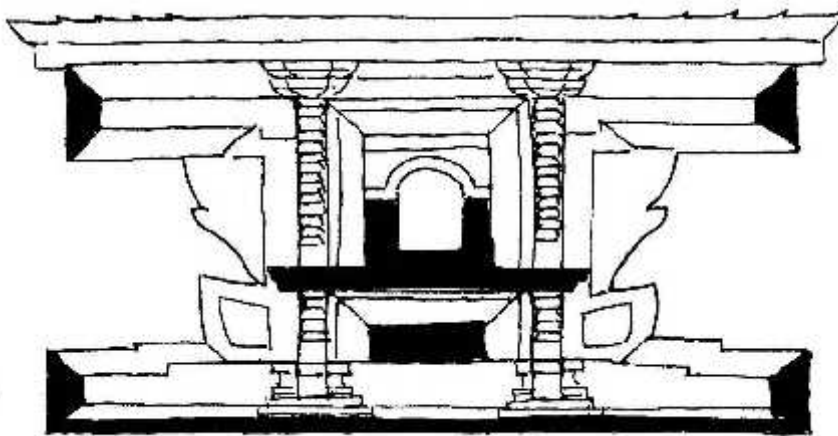

ID No.: B/K191-WIN(A) 02

Name: Ga Jhya

Monument: Maju Dega (Middle Storey)

Size: 170 X 290 cm at the widest.

Quantity: 1

Material: Wood

Currently stored at: Trishul Chowk

Remarks & Recommendation: The lost parts and unusable portions are to be recarved to make the window complete.

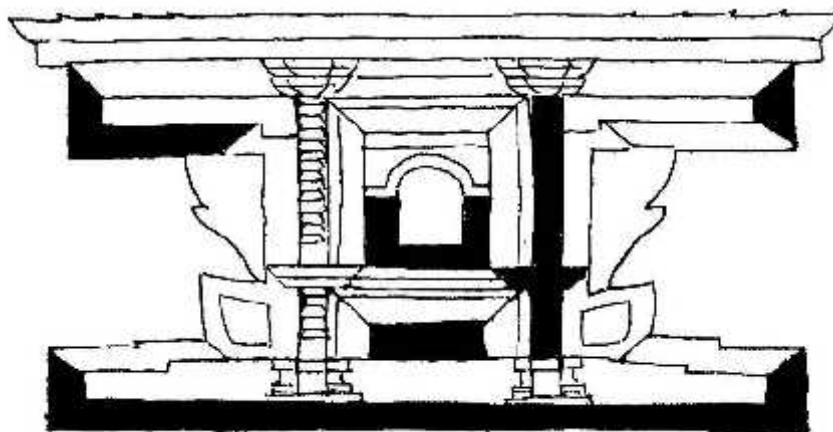

ID No.: B/K191-WIN(A) 03

Name: Ga Jhya

Monument: Maju Dega (Middle Storey)

Size: 170 X 287 cm at the widest

Quantity: 1

Material: Wood

Currently stored at: Trishul Chowk

Remarks & Recommendation: The lost parts and unusable portions are to be recarved to make the window complete.

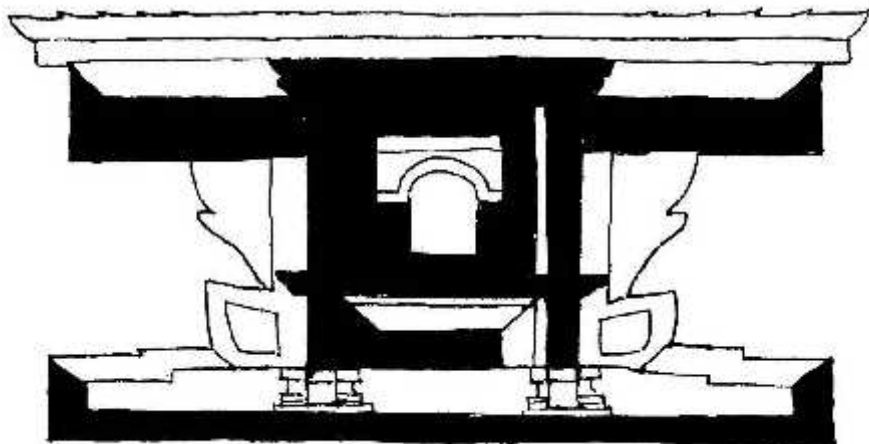

ID No.: B/K191-WIN(A) 04

Name: Ga Jhya

Monument: Maju Dega (Middle Storey)

Size: 175 X 285 cm at the widest.

Quantity: 1

Material: Wood

Currently stored at: Trishul Chowk

Remarks & Recommendation: The lost parts and unusable portions are to be recarved to make the window complete.

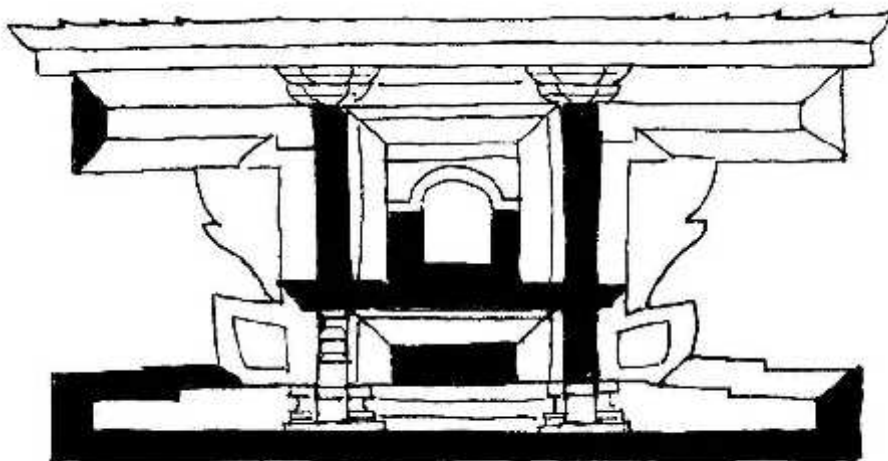

ID No.: B/K191-WIN(A) 05

Name: Ga Jhya

Monument: Maju Dega (Ground Storey)

Size: 280 X 175 cm

Quantity: 1

Material: Wood

Currently stored at: Trishul Chowk

Remarks & Recommendation: The lost parts and unusable portions are to be recarved to make the window complete.

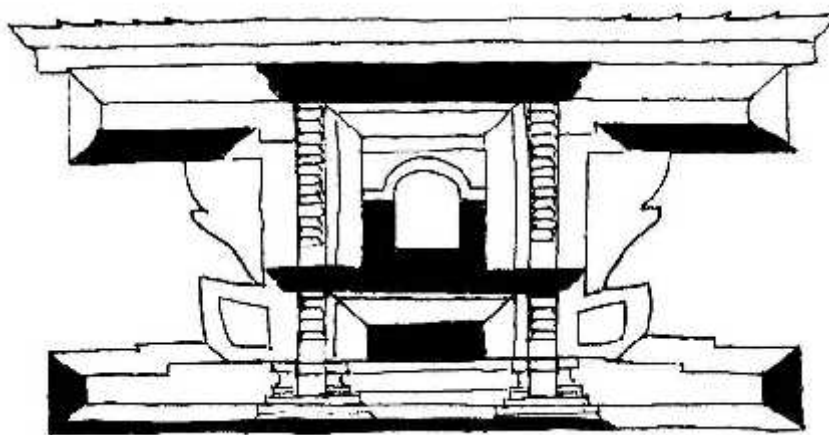

ID No.: B/K191-WIN(A) 06

Name: Ga Jhya

Monument: Maju Dega (Ground Storey)

Size: 270 X 175 cm

Quantity:

Material: Wood

Currently stored at: Trishul Chowk

Remarks & Recommendation: The lost parts and unusable portions are to be recarved to make the window complete.

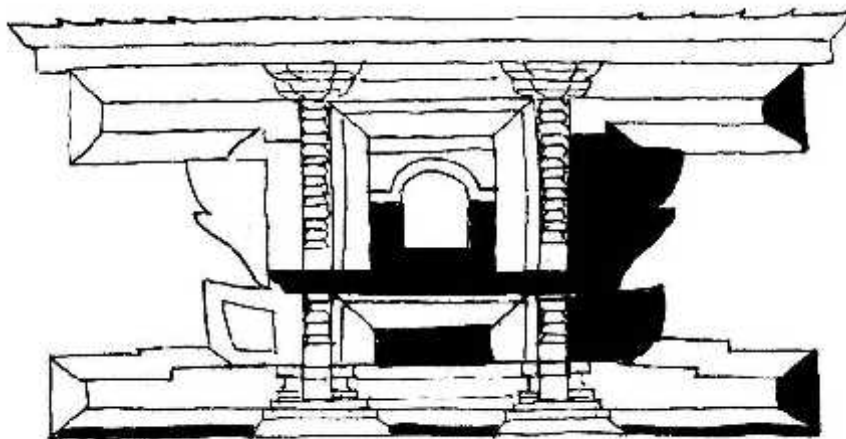

ID No.: B/K191-WIN(A) 07

Name: Ga Jhya

Monument: Maju Dega (Ground Storey)

Size: 280 x 170 cm

Quantity:1

Material: Wood

Currently stored at: Trishul Chowk

Remarks & Recommendation: The lost parts and unusable portions are to be recarved to make the window complete.

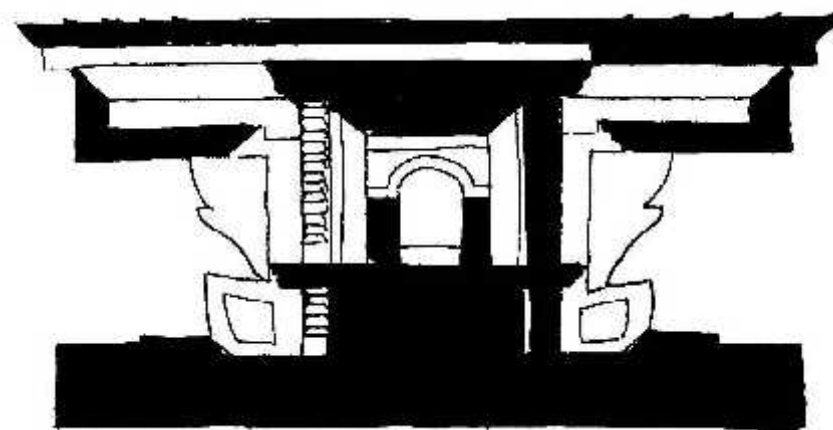

ID No.: B/K191-WIN(A) 08

Name: Ga Jhya

Monument: Maju Dega (Ground Storey)

Size:

Quantity:1

Material: Wood

Currently stored at: Trishul Chowk

Remarks & Recommendation: The lost parts and unusable portions are to be recarved to make the window complete.

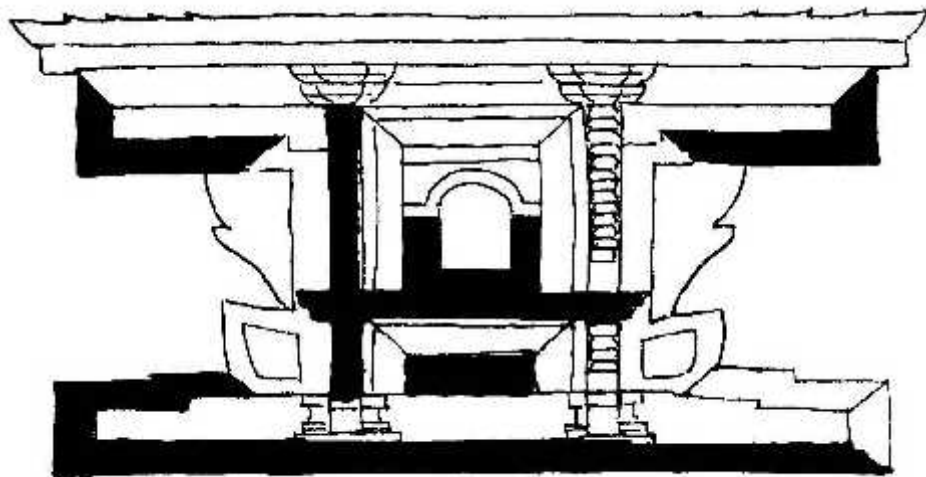

ID No.: B/K191-WIN(A) 09

Name: Ga jhya

Monument: Maju Dega (Top Storey)

Size: 216 X 132 cm

Quantity: 1

Material: Wood

Currently stored at: Trishul Chowk

Remarks & Recommendation: The lost parts and unusable portions are to be recarved to make the window complete.

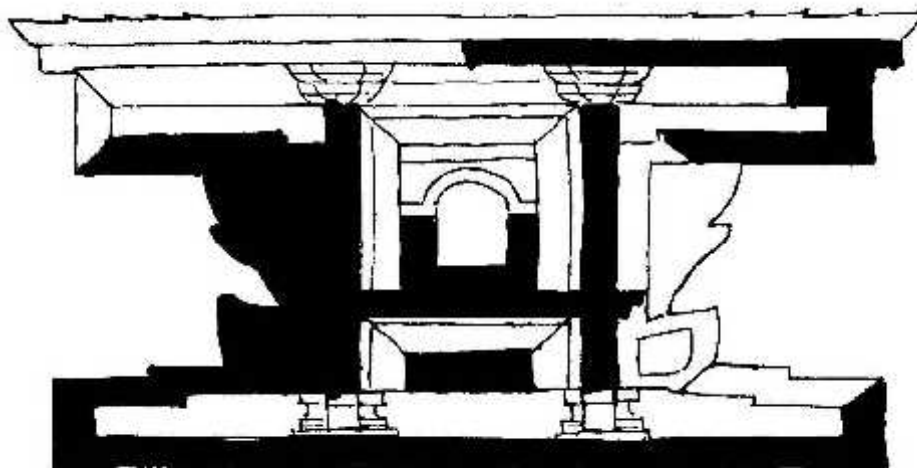

ID No.: B/K191-WIN(A) 10

Name: Ga jhya

Monument: Maju Dega (Top Storey)

Size: 216 X 132 cm

Quantity: 1

Material: Wood

Currently stored at: Trishul Chowk

Remarks & Recommendation: The lost parts and unusable portions are to be recarved to make the window complete.

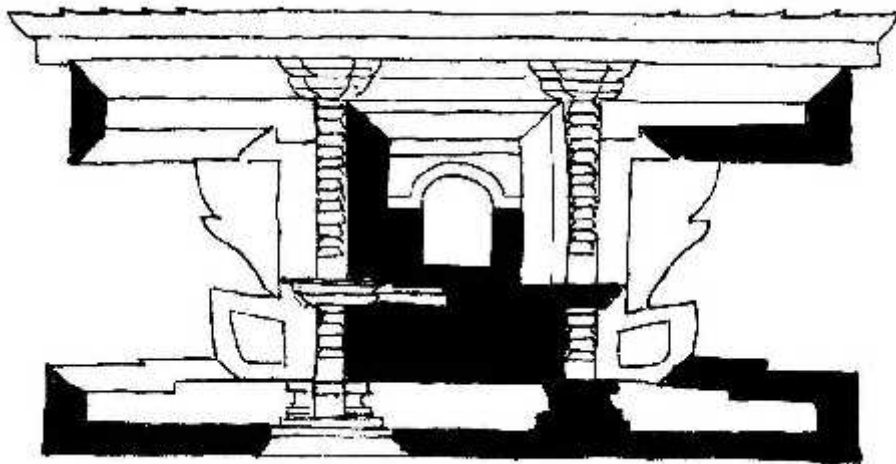

ID No.: B/K191-WIN(A) 11

Name: Ga jhya

Monument: Maju Dega (Top Storey)

Size: 216 X 132 cm

Quantity: 1

Material: Wood

Currently stored at: Trishul Chowk

Remarks & Recommendation: The lost parts and unusable portions are to be recarved to make the window complete.

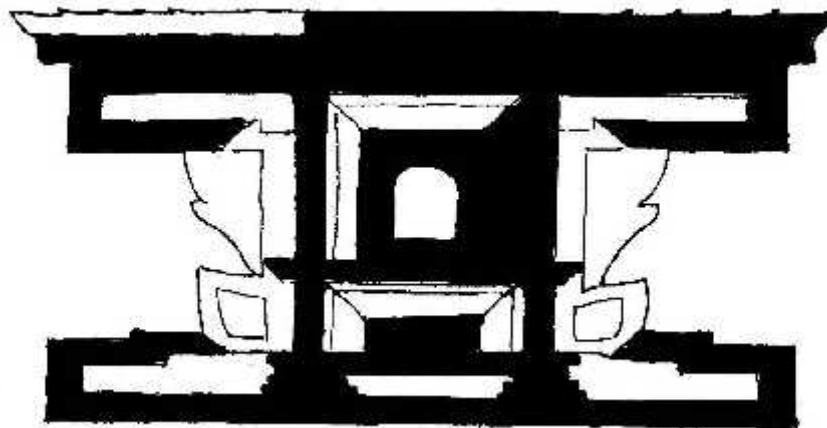

ID No.: B/K191-WIN(A) 12

Name: Ga jhya

Monument: Maju Dega (Top Storey)

Size: 216 X 132 cm

Quantity: 1

Material: Wood

Currently stored at: Trishul Chowk

Remarks & Recommendation: The lost parts and unusable portions are to be recarved to make the window complete.

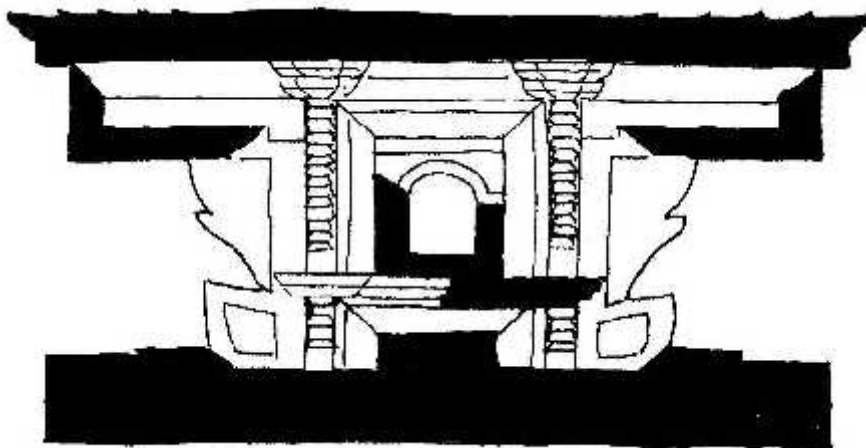

ID No.: B/K191-WIN(A) 13

Name: Ga jhya

Monument: Maju Dega (Ground Storey)

Size: 168 X 80 cm

Quantity: 1

Material: Wood

Currently stored at: Trishul Chowk

Remarks & Recommendation: The lost parts and unusable portions are to be recarved to make the window complete.

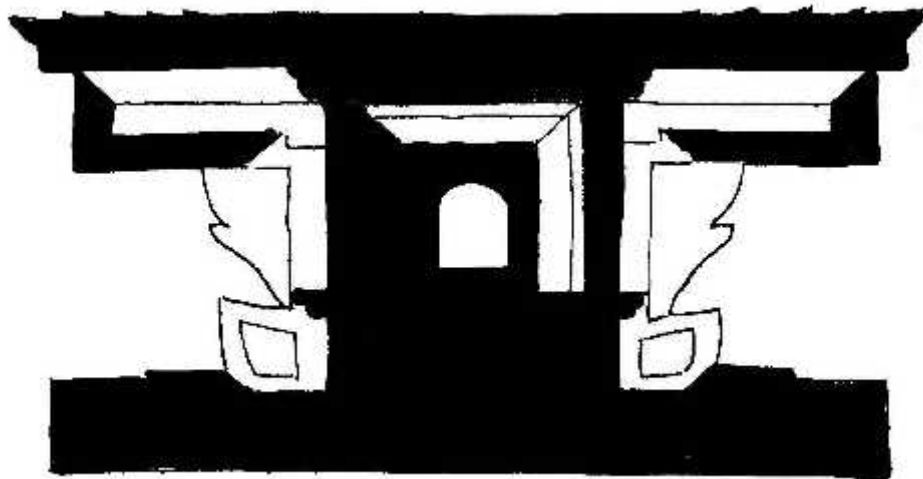

ID No.: B/K191-WIN(A) 14

Name: Ga jhya

Monument: Maju Dega (Ground Storey)

Size: 168 X 80 cm

Quantity: 1

Material: Wood

Currently stored at: Trishul Chowk

Remarks & Recommendation: The lost parts and unusable portions are to be recarved to make the window complete.

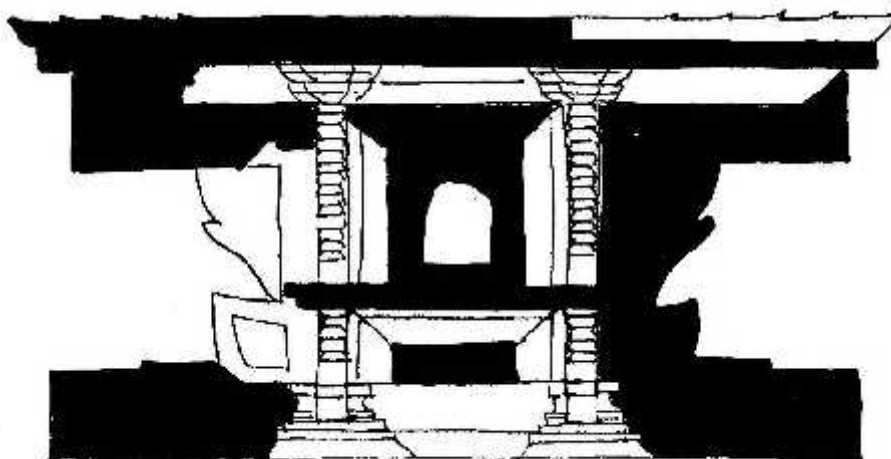

ID No.: B/K191-WIN(A) 15

Name: Ga jhya

Monument: Maju Dega (Ground Storey)

Size: 168 X 80 cm

Quantity: 1

Material: Wood

Currently stored at: Trishul Chowk

Remarks & Recommendation: The lost parts and unusable portions are to be recarved to make the window complete.

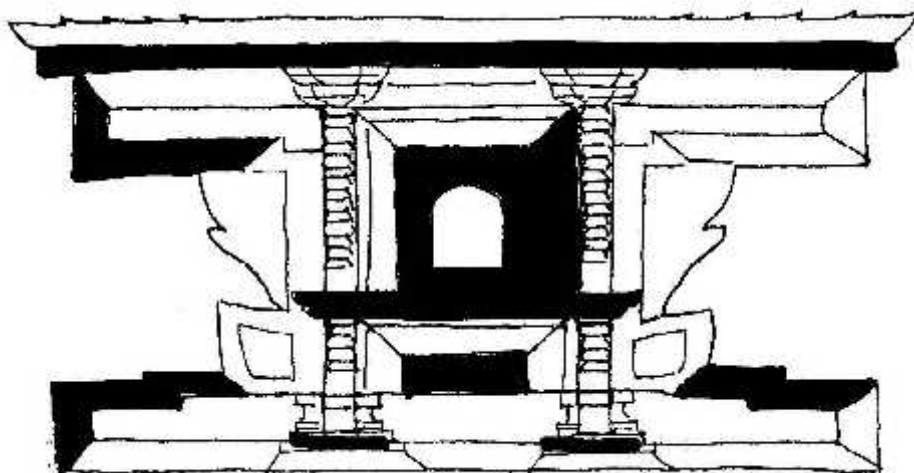

ID No.: B/K191-WIN(A) 16

Name: Ga jhya

Monument: Maju Dega (Ground Storey)

Size: 168 X 80 cm

Quantity: 1

Material: Wood

Currently stored at: Trishul Chowk

Remarks & Recommendation: The lost parts and unusable portions are to be recarved to make the window complete.

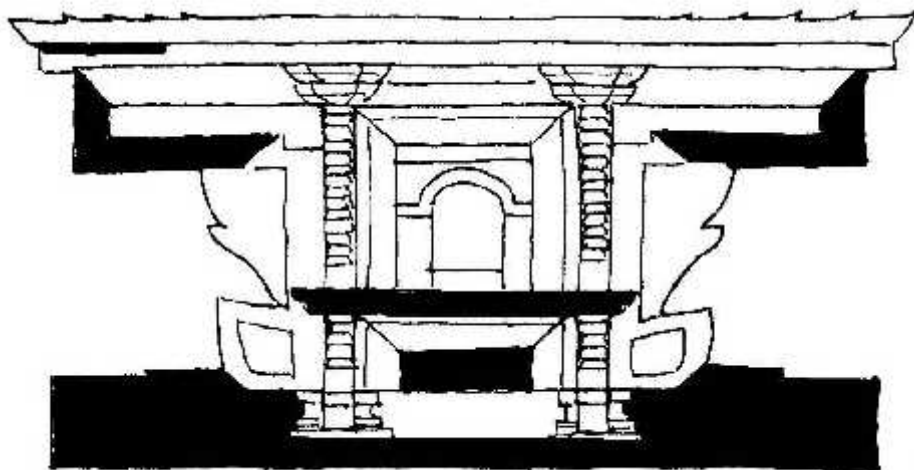

ID No.: B/K191-WIN(A) 17

Name: Ga jhya

Monument: Maju Dega (Ground Storey)

Size: 168 X 80 cm

Quantity: 1

Material: Wood

Currently stored at: Trishul Chowk

Remarks & Recommendation: The lost parts and unusable portions are to be recarved to make the window complete.

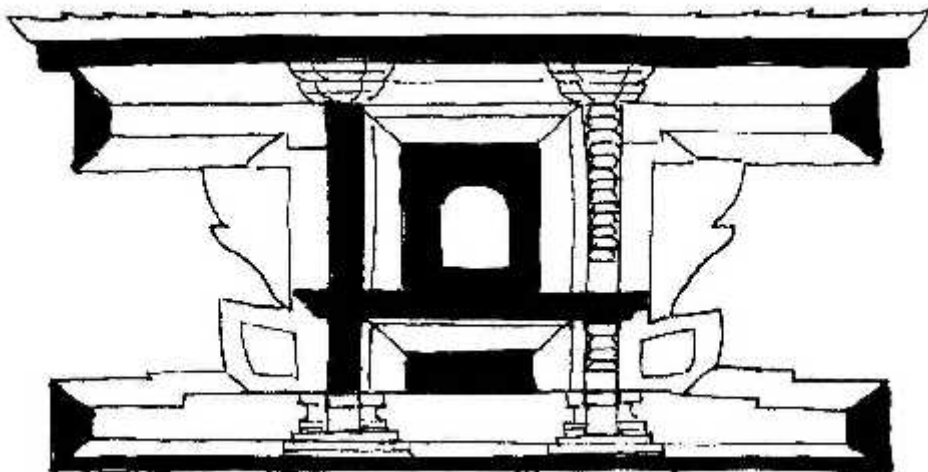

ID No.: B/K191-WIN(A) 18

Name: Ga jhya

Monument: Maju Dega (Ground Storey)

Size: 168 X 80 cm

Quantity: 1

Material: Wood

Currently stored at: Trishul Chowk

Remarks & Recommendation: The lost parts and unusable portions are to be recarved to make the window complete.

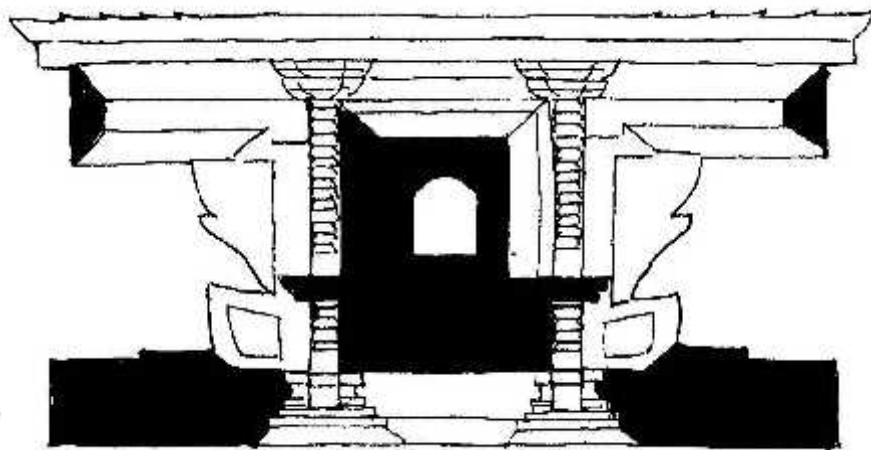

ID No.: B/K191-WIN(A) 19

Name: Ga jhya

Monument: Maju Dega (Ground Storey)

Size: 168 X 80 cm

Quantity: 1

Material: Wood

Currently stored at: Trishul Chowk

Remarks & Recommendation: The lost parts and unusable portions are to be recarved to make the window complete.

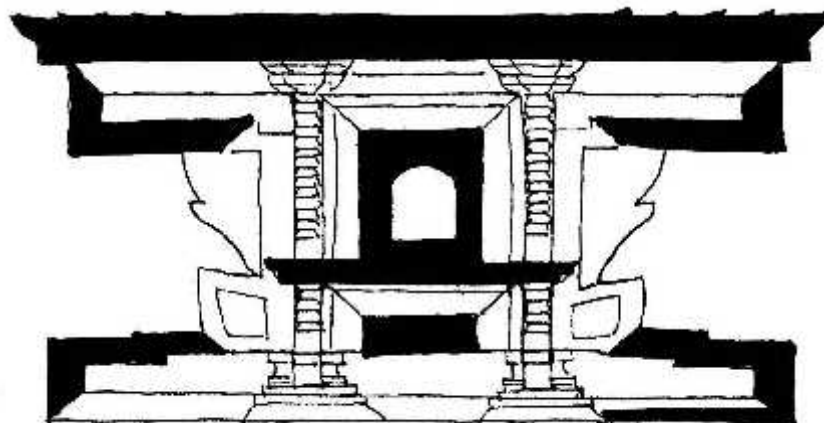

ID No.: B/K191-WIN(A) 20

Name: Ga jhya

Monument: Maju Dega (Ground Storey)

Size: 168 X 80 cm

Quantity:1

Material: Wood

Currently stored at: Trishul Chowk

Remarks & Recommendation: The lost parts and unusable portions are to be recarved to make the window complete.

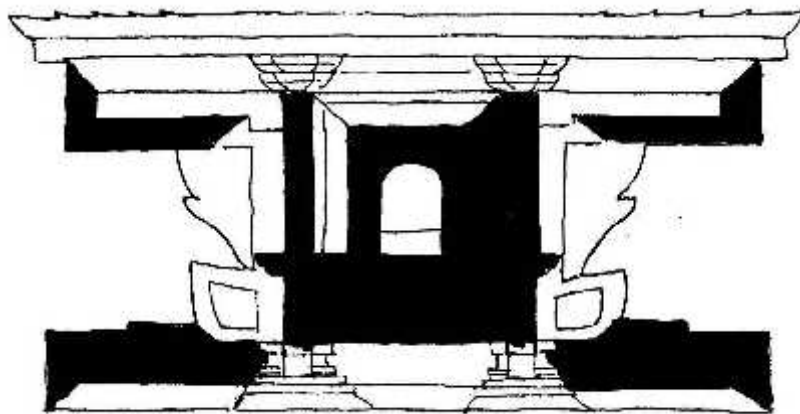

ID No.: B/K191-WIN(B) 01

Name: Partial part of Yaku Jhya

Monument: Maju Dega

Size: 95 X 65cm (when complete)

Quantity: 1

Material: Wood

Currently stored at: Shelter 1

Remarks & Recommendation: The lost parts and unusable portions are to be recarved to make the window complete.

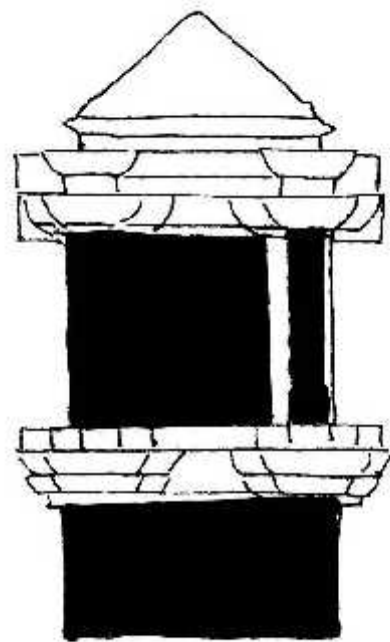

ID No.: B/K191-WIN(B) 02

Name: Partial part of Yaku Jhya

Monument: Maju Dega

Size: 95 X 65cm (when complete)

Quantity: 1

Material: Wood

Currently stored at: Shelter 1

Remarks & Recommendation: The lost parts and unusable portions are to be recarved to make the window complete.

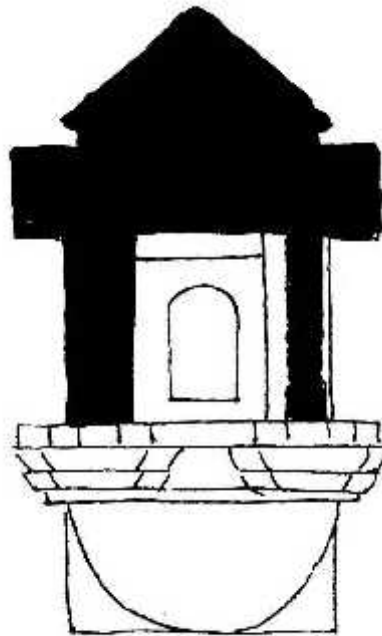

ID No.: B/K191-WIN(B) 03

Name: Yaku Jhya

Monument: Maju Dega

Size: 75 X 65cm

Quantity:1

Material: Wood

Currently stored at: Shelter 1

Remarks & Recommendation: The lost parts and unusable portions are to be recarved to make the window complete.

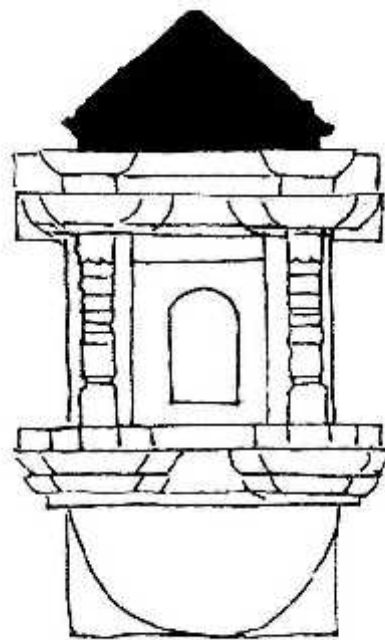

ID No.: B/K191-WIN(B) 04

Name: Yaku Jhya.

Monument: Maju Dega

Size: 95 X 65cm

Quantity:1

Material: Wood

Currently stored at: Shelter 1

Remarks & Recommendation: The lost parts and unusable portions are to be recarved to make the window complete.

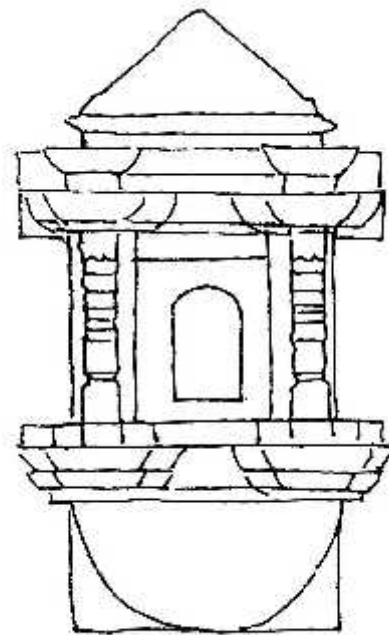

ID No.: B/K191-WIN(B) 05

Name: Yaku Jhya.

Monument: Maju Dega

Size: 90 X 65cm

Quantity: 1

Material: Wood

Currently stored at: Shelter 1

Remarks & Recommendation: The lost parts and unusable portions are to be recarved to make the window complete.

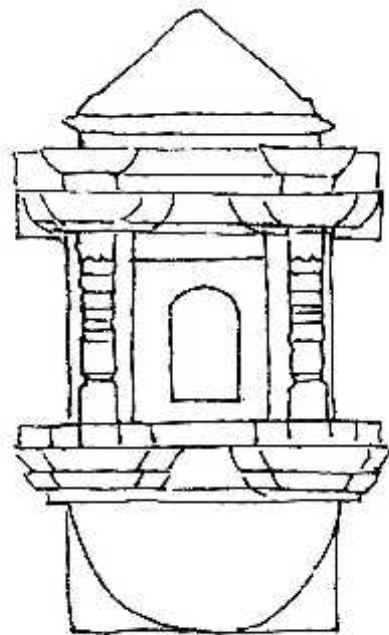

ID No.: B/K191-WIN(B) 06

Name: Yaku Jhya

Monument: Maju Dega

Size: 90 X 60cm

Quantity:1

Material: Wood

Currently stored at: Shelter 1

Remarks & Recommendation: The lost parts and unusable portions are to be recarved to make the window complete.

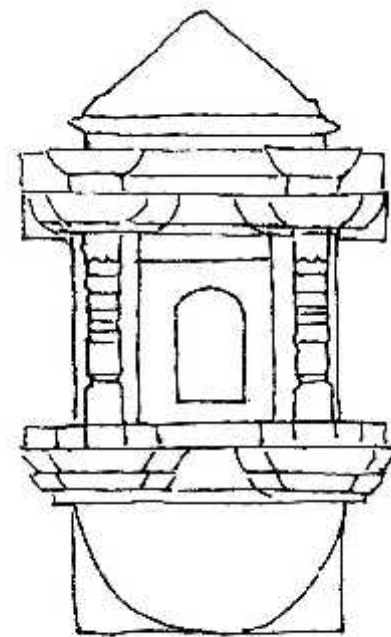

ID No.: B/K191-WIN(B) 07

Name: Yaku Jhya

Monument: Maju Dega

Size: 90 X 62cm

Quantity: 1

Material: Wood

Currently stored at: Shelter 1

Remarks & Recommendation: The lost parts and unusable portions are to be recarved to make the window complete.

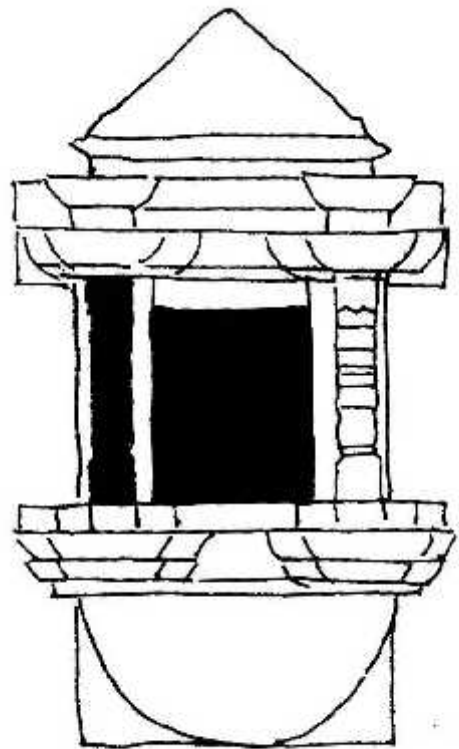

ID No.: B/K191-WIN(B) 08

Name: Yaku Jhya

Monument: Maju Dega

Size: 90 X 65cm

Quantity:1

Material: Wood

Currently stored at: Shelter 1

Remarks & Recommendation: The lost parts and unusable portions are to be recarved to make the window complete.

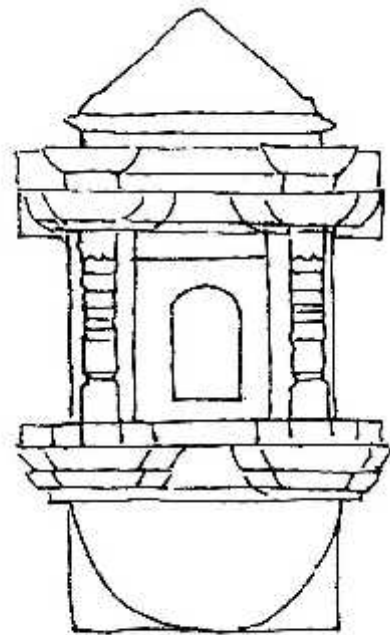

ID No.: B/K191-WIN(B) 09

Name: Yaku Jhya

Monument: Maju Dega (Middle Storey)

Size:

Quantity:1

Material: Wood

Currently stored at: Trishul Chowk

Remarks & Recommendation: More than half lost. The lost parts and unusable portions are to be recarved to make the window complete.

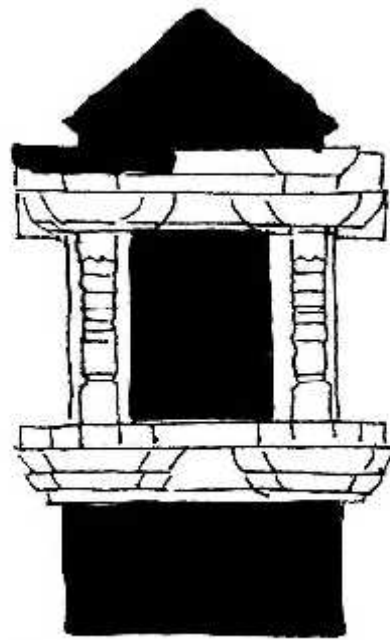

ID No.: B/K191-WIN(B) 10

Name: Yaku Jhya

Monument: Maju Dega (Middle Storey)

Size.

Quantity:1

Material: Wood

Currently stored at: Trishul Chowk

Remarks & Recommendation: The lost parts and unusable portions are to be recarved to make the window complete.

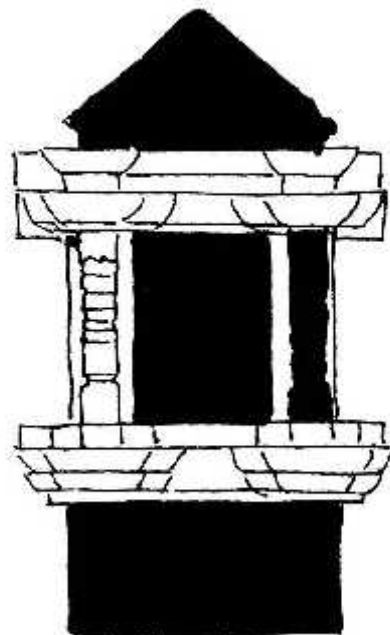

ID No.: B/K191-WIN(B) 11

Name: Yaku Jhya

Monument: Maju Dega

Size:

Quantity:1

Material: Wood

Currently stored at: Trishul Chowk

Remarks & Recommendation: The lost parts and unusable portions are to be recarved to make the window complete.

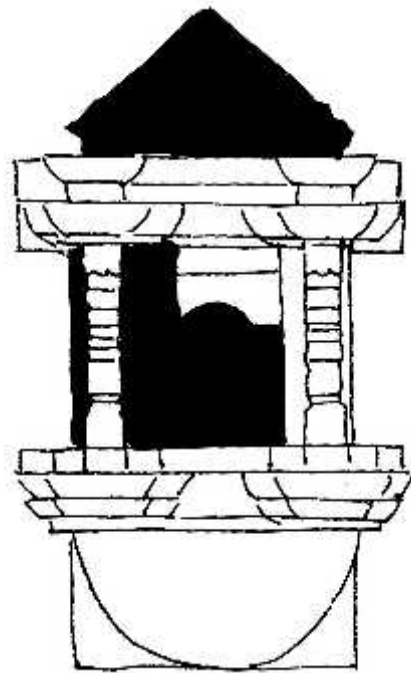

ID No.: B/K191-WIN(B) 12

Name: Yaku Jhya

Monument: Maju Dega

Size:

Quantity:1

Material: Wood

Currently stored at: Trishul Chowk

Remarks & Recommendation: The lost parts and unusable portions are to be recarved to make the window complete.

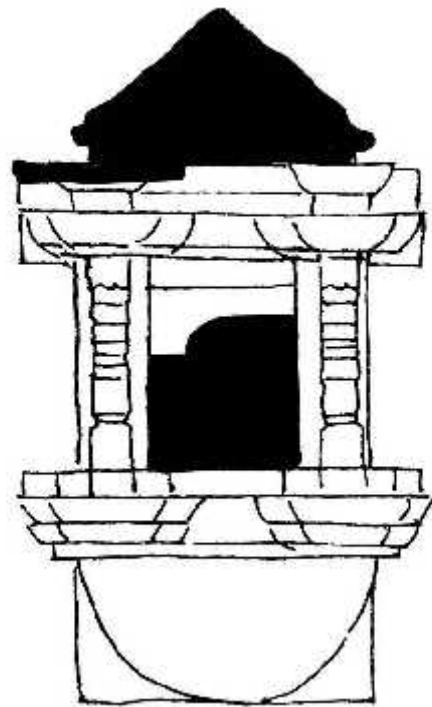

ID No.: B/K191-WIN(B) 13

Name: Yaku Jhya

Monument: Maju Dega

Size:

Quantity:1

Material: Wood

Currently stored at: Trishul Chowk

Remarks & Recommendation: The lost parts and unusable portions are to be recarved to make the window complete.

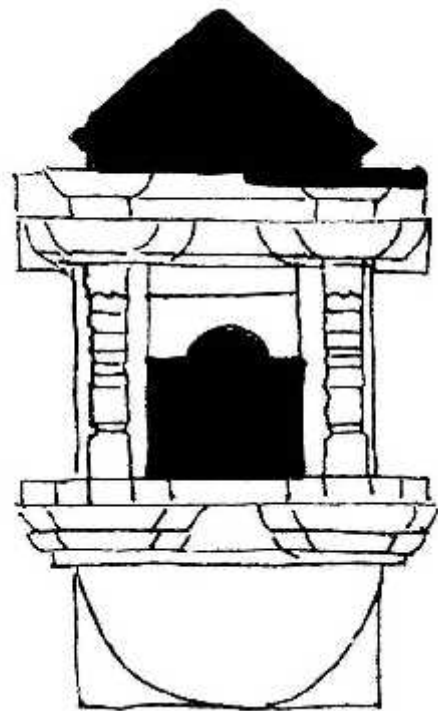

ID No.: B/K191-WIN(B) 14

Name: Yaku Jhya

Monument: Maju Dega

Size:

Quantity: 1

Material: Wood

Currently stored at: Trishul Chowk

Remarks & Recommendation: The lost parts and unusable portions are to be recarved to make the window complete.

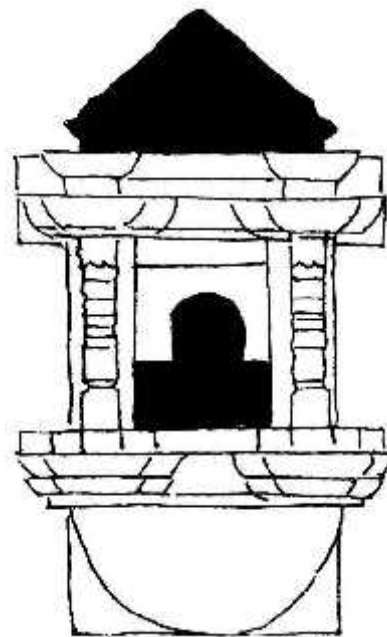

ID No.: B/K191-Door 1

Name: Door

Monument: Maju Dega

Size: 195 X 325 cm at the widest

Quantity: 1

Material: Wood

Currently stored at: Trishul Chowk

Remarks & Recommendation: Almost half lost. Recarve the lost part to make the door complete.

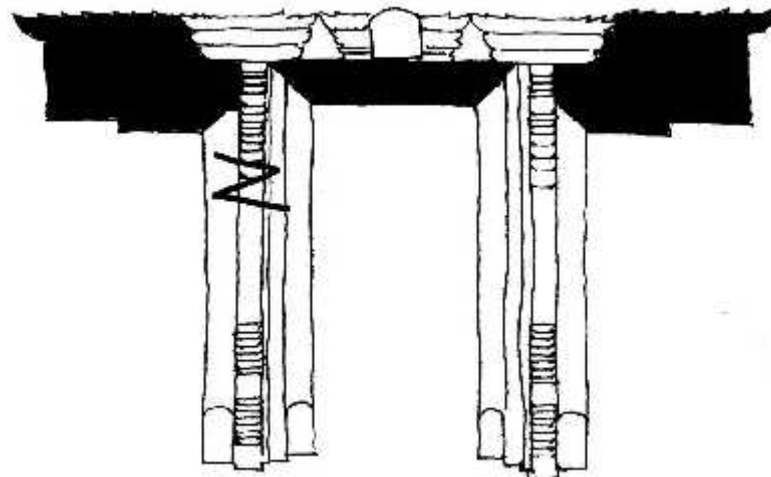

ID No.: B/K191-Door-2

Name: Door

Monument: Maju Dega

Size: 210 X 355 cm at the widest.

Quantity: 1

Material: Wood.

Currently stored at: Trishul Chowk

Remarks & Recommendation: 1/3 portion of the carved parts are lost. Recarve the lost part to make the door complete.

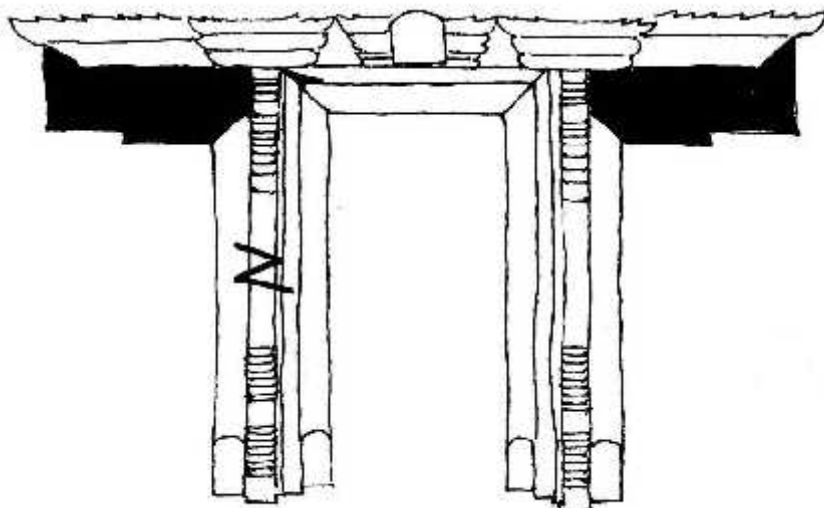

ID No.: B/K191-Door 3

Name: Door

Monument: Maju Dega

Size: 200 X 340 cm at the widest.

Quantity: 1

Material: Wood

Currently stored at: Trishul Chowk

Remarks & Recommendation: More than 50% carved members lost.

Make the new parts and fit to complete into a door.

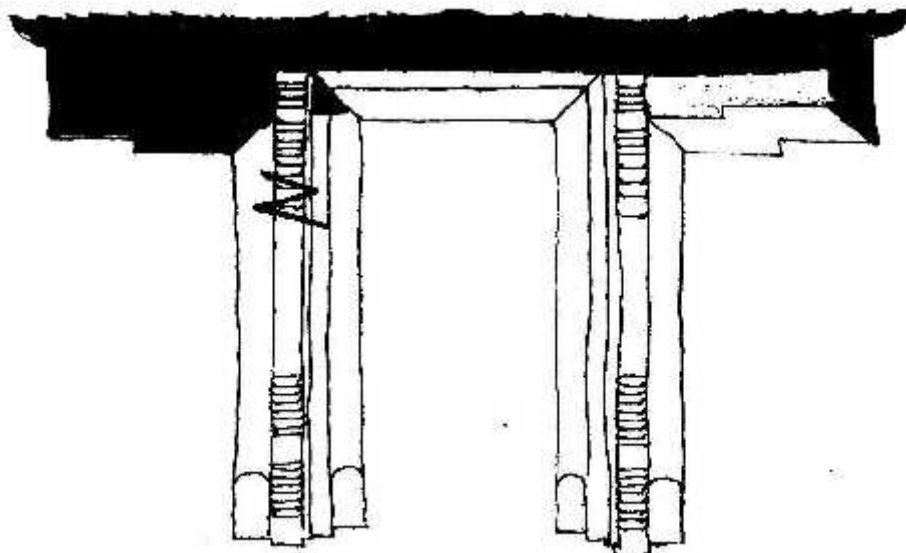

ID No.: B/K191-Door 4

Name: Door

Monument: Maju Dega

Size: 205 X 350 cm at the widest

Quantity: 1

Material: Wood

Currently stored at: Trishul Chowk

Remarks & Recommendation: More than half the percent of the carved members lost. Carve the new parts and refit it to complete the door.

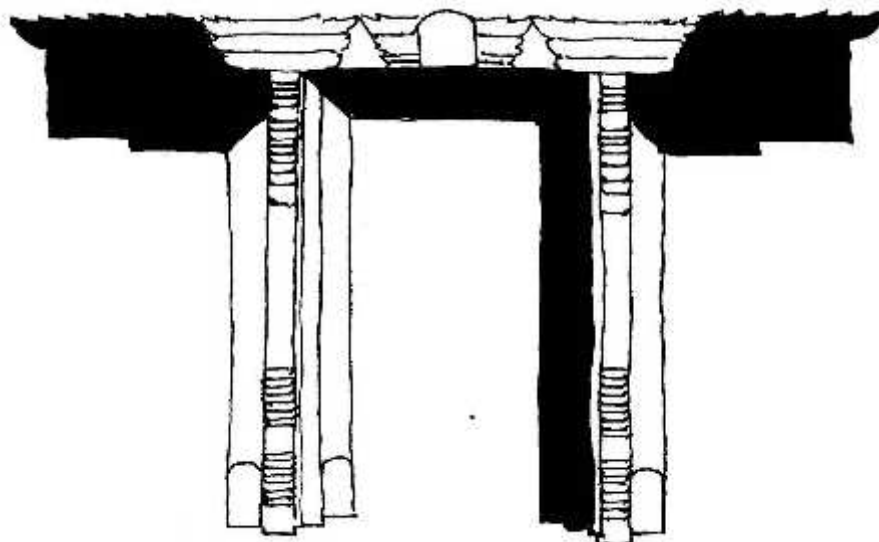

ID No.: B/K191-Door Panel

Name: Door Panel

Monument: Maju Dega

Size: 185 X 51 cm (as found)

Quantity: 1 (half panel)

Material: Wood

Currently stored at: Shelter 1

Remarks & Recommendation: Remake the second leaf and rest of the portions taking reference of the recovered part. (Note: There should be four pairs of panels in total)



ID No.: B/K191-PL 01

Name: Decorative Pillar

Monument: Maju Dega

Size: 205 X 26 X 26 cm

Quantity: 20

Material: Wood

Currently stored at: Shelter 2

Remarks & Recommendation: Remake the tenons. Fix them and then can be reused.



ID No.: B/K191-Meth

Name: Meth

Monument: Maju Dega

Size: 145 X 20 X 25 cm (Full Meth), 110 X 20 X 18 cm (Half Meth)

Quantity: Full Meth – 14 nos. complete /2 nos. broken, Half Meth – 8 nos.
complete / rest broken.

Material: Wood

Currently stored at: Shelter 1

Remarks & Recommendation: : Remake the broken pieces taking reference of
the complete ones. (In actual condition, there should be 16 complete meths and
16 half meths)



ID No.: B/K191-CH

Name: Chakulaan

Monument: Maju Dega

Size: 40 X 43 cm

Quantity: 20 (almost all broken)

Material: Wood

Currently stored at: Shelter 1



Remarks & Recommendation: Needs extensive repair to be reused. Rebuilding new ones is recommended or stitch them using new timber lock.

ID No.: B/K191-Dh

Name: Dhalinkhwa

Monument: Maju Dega

Size: Varies

Quantity: More than 150

Material: Wood

Currently stored at: Shelter 1

Remarks & Recommendation: Almost all of those recovered are in good condition. Some may need repair.



ID No.: B/K191-ICON(S)

Name: Stone Icon of Mritunjaya

Monument: Maju Dega

Size: 65 X 50 cm

Quantity: 1

Material: Stone

Currently stored at: Nhulachhen Chowk

Remarks & Recommendation: Give a wash and
reconsecrate.



SANTANESVARA TEMPLE (B/K-191b)

01. Stone Icon

02. Door

03. Stone Pillar

ID No. : B/K191B-ICON(S) 01

Name: Stone Image of Santanesvara

Monument: Santanesvara Temple.

Size: 52 X 106 cm

Quantity: 1

Material: Stone

Currently stored at: Nhulachhen Chowk

Remarks & Recommendation: Clean the
image and refit in the temple.



ID No.: B/K 191(b)-Door

Name: Door

Monument: Santanesvara Temple

Size: 122 X 110 cm

Quantity:1

Material: Wood

Currently stored at: Shelter 1

Remarks & Recommendation: Still good and can be reused but two tolanthan are missing and have to be replaced. The base stone has to be recovered. The present three parts stood on stone base that is absent now. The black japan has to be removed by some chemical cleansing agents. The whole body should be chemically cleaned with suitable chemical combination.



ID No.: B/K 191(b)-Pillar

Name: Stone Pillar

Monument: Santanesvara Temple

Size: 135 X 16 X 16 cm

Quantity: 1 (1 lost)

Material: Stone

Currently stored at: Nhulachhen Chowk.

Remarks & Recommendation: Can be reused with some treatment. The lost one to be replicated with reference to recovered one.



GARUD NARAYAN TEMPLE (B/K-189)

01. Struts

02. Kunsala

03. Windows

04. Doors

05. Door Panel

06. Pillar

07. Meth

08. Chakulaan

09. Dhalinkhwa

10. Stone Icon

11. Decorative Piece

ID No.: B/K 189-TDL 01

Name: Standing divine figure of a male God.

Monument: Garud Narayan Temple

Size: 169 X 23 X 11 cm

Quantity: 1

Material: Wood

Currently stored at: Shelter 1

Remarks & Recommendation: Half rotten and erosion effect is adequately noticed. Left shoulder to the feet is almost fragile. Only head and below feet are intact and more durable. Both hands are gone. Middle portion of the strut is time eroded. Therefore it has to be checked for reuse to know its strength. If used needs careful re-strengthening from three sides except front.



ID No.: B/K 189-TDL 02

Name: Divine figure with two hands.

Monument: Garud Narayan Temple

Size: (169+2) X 24 X 10 cm

Quantity: 1

Material: Wood

Currently stored at: Shelter 1

Remarks & Recommendation: Both hands are gone, bottom portion is little rotten. Rest is still in good condition. Nice depiction of a male enticing his wife carved in the pedestal. Red washed; therefore a soda wash is enough to clean.

Supporting beams while reusing is recommended.



ID No.: B/K 189-TDL 03

Name: Two handed divine figure.

Monument: Garud Narayan Temple

Size: (170+2) X 22.5 X 11 cm

Quantity: 1

Material: Wood

Currently stored at: Shelter 1

Remarks & Recommendation: Nose is broken off at the middle portion vertically. Rest is still strong enough. Both hands are gone. Slight soda wash or sandblasting is recommended. Social depiction is portrayed at the pedestal, instead of Erotic.



ID No.: B/K 189-TDL 04

Name: Two handed divine figure.

Monument: Garud Narayan Temple

Size: (171+6) X 22 X 11 cm

Quantity: 1

Material: Wood

Currently stored at: Shelter 1

Remarks & Recommendation: The wood condition is still good.
Two hands are broken off. Can be directly reused after adding
hands.



ID No.: B/K 189-TDL 05

Name: Two handed divine figure.

Monument: Garud Narayan Temple

Size: (164+8) X 22 X 10 cm

Quantity: 1

Material: Wooden.

Currently stored at: Shelter 1

Remarks & Recommendation: The timber condition is still good.
Can be reused with slight wash. Both hands are gone off. The
hands of female and knees of the male figure in pedestal part
have broken off.



ID No. : B/K 189-TDL 06

Name : Two handed divine figure.

Monument: Garud Narayan Temple

Size: 177 X 24 X 10cm

Quantity:1

Material: Wood

Currently stored at: Shelter 1

Remarks & Recommendation: The strut is still intact. The two hands are gone off. Refit the hands and reuse.



ID No. : B/K 189-TDL 07

Name : Two handed divine figure.

Monument: Garud Narayan Temple

Size: 176 X 23 X 10 cm

Quantity:1

Material: Wood

Currently stored at: Shelter 1

Remarks & Recommendation: Some small flakes are gone off. Still quite nice to reuse by adding two hands. Can be reused despite some small flakes.



ID No. : B/K 189-TDL 08

Name : Two handed divine figure.

Monument: Garud Narayan Temple

Size: 170 X 24 X 10 cm

Quantity: 1

Material: Wood

Currently stored at: Shelter 1

Remarks & Recommendation: Middle portion of the strut is time wormed due to the water percolation, flower patterns on both sides are half gone. Cannot be recommended to reuse. Give it to the museum.



ID No. : B/K 189-TDL 09

Name : Two handed divine figure.

Monument: Garud Narayan Temple

Size: 170 X 24 X 10 cm

Quantity:1

Material: Wood

Currently stored at: Shelter 1

Remarks & Recommendation: Only figure of Narayan is discernible. Very much worn out. Not advisable at all for reuse due to too much fragile condition.



ID No. : B/K 189-TDL 10

Name : Two handed divine figure.

Monument: Garud Narayan Temple

Size: 170 X 24 X 10 cm

Quantity:1

Material: Wood

Currently stored at: Shelter 1

Remarks & Recommendation: Still intact. Can be directly reused by adding the hands.



ID No.: B/K 189-TDL 11

Name. : Two handed divine figure.

Monument: Garud Narayan Temple

Size: (165+2) X 24 X 10 cm

Quantity: 1

Material: Wood

Currently stored at: Shelter 1

Remarks & Recommendation: Only a small portion to the right of pedestal portion is rotten away due to the water percolation. Both hands are broken off. Rest intact and the whole body is reddish wash given. Though looks strong, a supporting beam is recommended to the right side of the strut. Slight wash or sandblasting is recommended. Pedestal portion is depicted with social activity than erotic.



ID No.: B/K 189-TDL 12

Name: Perhaps the figure of a nymph

Monument: Garud Narayan Temple

Size: (147+3) X 25 X 12 cm

Quantity:1

Material: Wood

Currently stored at: Shelter 1

Remarks & Recommendation: Two hands are gone. Condition of the wood is still strong and reusable. The complete figure is still intact. Recognizable with no riding animals but of a plant pattern. Giving two side supports is recommended while fixing the strut. Either soda wash or a slight sand blasting could bring the image in prominent lood. Floral crown is given on the head.



ID No.: B/K 189-TDL 13

Name: Male figure.

Monument: Garud Narayan Temple

Size: (146+3) X 23 X 13 cm

Quantity:1

Material: Wood

Currently stored at: Shelter 1

Remarks & Recommendation: Two hands were gone that were joined later. Condition of wood is still intact. Figure stands on left leg with Tribhanga posture. The main figure is flanked by two birds of which half the body is gone and another one's head is gone. Giving two side supports is recommended while fixing in the temple. Either slight sand blasting of soda wash would be recommended.



ID No.: B/K 189-TDL 14

Name: A nymph.

Monument: Garud Narayan Temple

Size: (147+4) X 29 X 11 cm

Quantity:1

Material: Wood

Currently stored at: Shelter 1

Remarks & Recommendation: Two hands are broken off also the half of left breast similarly nose and bell portion also partially eroded. Noticed slight damp and insect attack from the top. The figure is nicely feministic and stands on a lotus. Only slight sand blasting is recommended. The support stubs are highly necessary if reused. Two flower pattern base. Floral crown is given above the head.



ID No.: B/K 189-TDL 15

Name: Male figure of a god.

Monument: Garud Narayan Temple

Size: (150+2) X 23.5 X 11 cm

Quantity:1

Material: Wood

Currently stored at: Shelter 1

Remarks & Recommendation: Male figure having both hands broken off. The condition of the wood is partially rotten but still good enough to use with supports in both sides. Heads of the asana birds gone off. Two supports are necessary to use in the future. Slight soda wash or a soft sand blasting recommended.



ID No.: B/K 189-TDL 16

Name: Male God standing on Tribhanga.

Monument: Garud Narayan Temple

Size: (150+2) X 24.5 X 12 cm

Quantity:1

Material: Wood

Currently stored at: Shelter 1

Remarks & Recommendation: Unfinished and unused piece of the strut. Male God standing on Tribhanga. Both hands not yet fixed. Beaks of both birds are gone. Caustic soda wash or a slight sand blasting recommended.



ID No.: B/K 189-TDL 17

Name. : Two Handed male God standing in Tribhanga.

Monument: Garud Narayan Temple

Size: (147+4) X 23 X 11 cm

Quantity: 1

Material: Wood

Currently stored at: Shelter 1

Remarks & Recommendation: Very good condition. Two hands are gone. Two birds in the pedestal, both intact, can be reused after adding forehands.



ID No.: B/K 189-TDL 18

Name: Two handed Goddess standing in Tribhanga.

Monument: Garud Narayan Temple

Size: (163+6) X 20 X 11.5 cm

Quantity: 1

Material: Wood

Currently stored at: Shelter 1

Remarks & Recommendation: Almost rotten, not reusable. If used should be given enough support from three sides left right and from the back. One of the birds in the base is gone. Rest one also having no head. Provide hands and attributes. Give light wash with soda.



ID No. : B/K 189-TDL 19

Name : Two handed divine figure.

Monument: Garud Narayan Temple

Size: 174 X 24 X 13 cm

Quantity:1

Material: Wood

Currently stored at: Shelter 1

Remarks & Recommendation: Still intact, can be reused
after adding forehands.



ID No.: B/K 189-TDL 20

Name: Two handed divine figure.

Monument: Garud Narayan Temple

Size: (148+9) X 18.5 X 13 cm

Quantity: 1

Material: Wood

Currently stored at: Shelter 1

Remarks & Recommendation: Both hands are gone and body is badly rotten due to the water percolation. Though rotten slight could be reused with providing supports on both sides.



ID No.: B/K 189-TDL 21

Name: Two handed divine figure.

Monument: Garud Narayan Temple

Size: (146+7) X 23 X 11 cm

Quantity: 1

Material: Wood

Currently stored at: Shelter 1

Remarks & Recommendation: Right foot is broken of and also two hands. The wood condition is still excellent. Two birds are decorated in pedestal part. The beak of left one is gone.



ID No. : B/K 189-TDL 22

Name : Two handed figure of a lady.

Monument: Garud Narayan Temple

Size: 154 X 24 X 14 cm

Quantity:1

Material: Wood

Currently stored at: Shelter 1

Remarks & Recommendation: Can be reused by adding
forearms.



ID No.: B/K 189-TDL 23

Name: Two handed figure of a lady.

Monument: Garud Narayan Temple

Size: (146+7) X 23 X 12 cm

Quantity: 1

Material: Wood

Currently stored at: Shelter 1

Remarks & Recommendation: The wooden condition is excellent. Two forearms are broken off and can be reused with fixing two hands.



ID No.: B/K 189-TDL 24

Name: Male figure of a God.

Monument: Garud Narayan.

Size: (147+4) X 17 X 11 cm

Quantity:1

Material: Wood

Currently stored at: Shelter 1

Remarks & Recommendation: Good condition. The hands were not even titled, therefore probably never used till date. Right one bird's head broken off. Can be used now in the temple.



ID No.: B/K 189-TDL 25

Name: Standing male God.

Monument: Garud Narayan Temple

Size: (145+2) X 18 X 11 cm

Quantity: 1

Material: Wood

Currently stored at: Shelter 1

Remarks & Recommendation: Almost intact except two hands not yet joined. Can be reused directly by adding hands. The wood is still intact.



ID No.: B/K 189-TDL 26

Name: Male God.

Monument: Garud Narayan Temple

Size: (146+6) X 20 X 12.5 cm

Quantity: 1

Material: Wood

Currently stored at: Shelter 1

Remarks & Recommendation: Everything is intact except absent hands. Give a wash, add the hands and reuse. The wood is still intact.



ID No.: B/K 189-TDL 27

Name: Two armed male divine figure.

Monument: Garud Narayan Temple

Size: (144+2) X 19.6 X 12.5 cm

Quantity:1

Material: Wood

Currently stored at: Shelter 1

Remarks & Recommendation: Everything intact except two hands that are not yet fixed. Slight piece of the beak in one of the bird is broken off. One caustic soda wash is enough. Can be reused if provided with two hands.



ID No.: B/K 189-TDL 28

Name: Two handed Benudhara Bishnu (Krishna)

Monument: Garud Narayan Temple

Size: (109+1) X 20 X 10 cm

Quantity: 1

Material: Wood

Currently stored at: Shelter 1

Remarks & Recommendation: Base is rotten but could be reused. In Totality in good condition. Hand scarf is attached piece but broken off. Social couple scene is depicted in the pedestal.



ID No.: B/K 189-TDL 29

Name: Salabhanjika figure of a Devi

Monument: Garud Narayan Temple

Size: (108+6) X 20 X 10 cm

Quantity: 1

Material: Wood

Currently stored at: Shelter 1

Remarks & Recommendation: The figure looks nicely feministic raising the left hand above the head as if touching the branch of a tree with blooming flower. Right hand is pendant and her attribute is not recognizable. Left hand holds some pot. An amorous couple is carved below the main figure. The figures of pedestal are shown in amorous nature.



ID No.: B/K 189-TDL 30

Name: Salabhanjika figure of a Devi

Monument: Garud Narayan Temple

Size: (112+6) X 18 X 10 cm

Quantity: 1

Material: Wood

Currently stored at: Shelter 1

Remarks & Recommendation: Right portion of the bottom is broken off. Slightly eroded in totality and vertical crack is noticed. The supporting pillar on both sides is recommended if reused in future.



ID No.: B/K 189-TDL 31

Name: Salabhanjika figure of a Devi

Monument: Garud Narayan Temple

Size: 110.5 X 18 X 9.5 cm

Quantity: 1

Material: Wood

Currently stored at: Shelter 1

Remarks & Recommendation: The flowers on top are broken off on both sides and central two flowers are still intact. Right hand palm is gone off. Advisable to give two support pillars in both sides if reused.



ID No. : B/K 189-TDL 32

Name : Two handed Benudhara Bishnu (Krishna)

Monument: Garud Narayan Temple

Size: 112 X 21 X 11 cm

Quantity:1

Material: Wood

Currently stored at: Shelter 1

Remarks & Recommendation: Almost intact. Give a wash and can be reused directly.



ID No. : B/K 189-TDL 33

Name : Two handed Benudhara Bishnu (Krishna)

Monument: Garud Narayan Temple

Size: 115 X 20 X 11 cm

Quantity:1

Material: Wood

Currently stored at: Shelter 1

Remarks & Recommendation: Top left is gone (flaked off) and right portion of the god is broken off, surrounding are all eroded flaked off leaving no edges.

Give supporting beams if it has to be reused.



ID No. : B/K 189-TDL 34

Name : N/A

Monument: Garud Narayan Temple

Size: 174 X 24 X 14 cm

Quantity:1

Material: Wood

Currently stored at: Shelter 1

Remarks & Recommendation: Still intact despite some
small flakes. Can be directly reused.



ID No.: B/K 189-K01

Name: Kunsala (Corner Strut)

Monument: Garud Narayan Temple

Size. : 224.5 X 18 X 20 cm

Quantity: 1

Material: Wood

Currently stored at: Shelter 1

Remarks & Recommendation: Could be
directly reused.



ID No.: B/K 189-K02

Name: Kunsala (Corner Strut)

Monument: Garud Narayan Temple

Size. : 209 X 18 X 21 cm

Quantity: 1

Currently stored at: Shelter 1

Material: Wood

Remarks & Recommendation: Lizard figure is broken but still saved and tied in situ. Refix the figure of lizard and give a knot tightening at the middle then reuse.



ID No.: B/K 189-K03

Name: Kunsala (Corner Strut)

Monument: Garud Narayan Temple

Size. : 204 X 18 X 20 cm

Quantity: 1

Material: Wood

Currently stored at: Shelter 1

Remarks & Recommendation: Give
a strengthening with a knot bolt in
lower portion then reuse.



ID No.: B/K 189-K04

Name: Kunsala (Corner Strut)

Monument: Garud Narayan Temple

Size. : 203 X 18 X 20 cm

Quantity: 1

Material: Wood

Currently stored at: Shelter 1

Remarks & Recommendation: Right
arm (Paw) of the lion is flaked off.
Rest is ok. Remake the right paw and
fix then the strut could be directly
reused.



ID No.: B/K 189-K05

Name: Kunsala (Corner Strut)

Monument: Garud Narayan Temple

Size. : 195.5 X 18 X 20 cm

Quantity: 1

Material: Wood

Currently stored at: Shelter 1

Remarks & Recommendation: Almost
intact. Can be reused again.



ID No.: B/K 189-K06

Name: Kunsala (Corner Strut)

Monument: Garud Narayan Temple

Size. : 193 X 18 X 20 cm

Quantity: 1

Material: Wood

Currently stored at: Shelter 1

Remarks & Recommendation: Almost
intact. Can be directly reused.



ID No.: B/K 189-K07

Name: Kunsala (Corner Strut)

Monument: Garud Narayan Temple

Size. : 200 X 18 X 20 cm

Quantity: 1

Material: Wood

Currently stored at: Shelter 1

Remarks & Recommendation: Still
intact. Can be directly reused.



ID No.: B/K 189-K08

Name: Kunsala (Corner Strut)

Monument: Garud Narayan Temple

Size. : 199 X 15 X 18 cm

Quantity: 1

Material: Wood

Currently stored at: Shelter 1

Remarks & Recommendation: Part below the left arm is flaked off and phallus with the monkey is gone and left horn also no more. Remake the phallus, monkey and horn then refix the portion below the left arm.



ID No.: B/K 189-K09

Name: Kunsala (Corner Strut)

Monument: Garud Narayan Temple

Size. : 137 X 13.5 X 18 cm

Quantity: 1

Material: Wood

Currently stored at: Shelter 1

Remarks & Recommendation: Still
intact. Can be reused directly.



ID No.: B/K 189-K10

Name: Kunsala (Corner Strut)

Monument: Garud Narayan Temple

Size. : 135 X 10 X 19 cm

Quantity: 1

Material: Wood

Currently stored at: Shelter 1

Remarks & Recommendation: Still
intact. Can be directly reused.



ID No.: B/K 189-K11

Name: Kunsala (Corner Strut)

Monument: Garud Narayan Temple

Size. : 130 X 10 X 20 cm

Quantity: 1

Material: Wood

Currently stored at: Shelter 1

Remarks & Recommendation: Still
intact. Can be directly reused.



ID No.: B/K 189-WIN(A) 01

Name: Ga Jhya

Monument: Garud Narayan Temple

Size: 75 X 117 cm

Quantity: 1

Material: Wood.

Currently stored at: Nasal Chowk.

Remarks & Recommendations: Slightly broken off in center. Rest is ok. Fixing that much can be reused again.

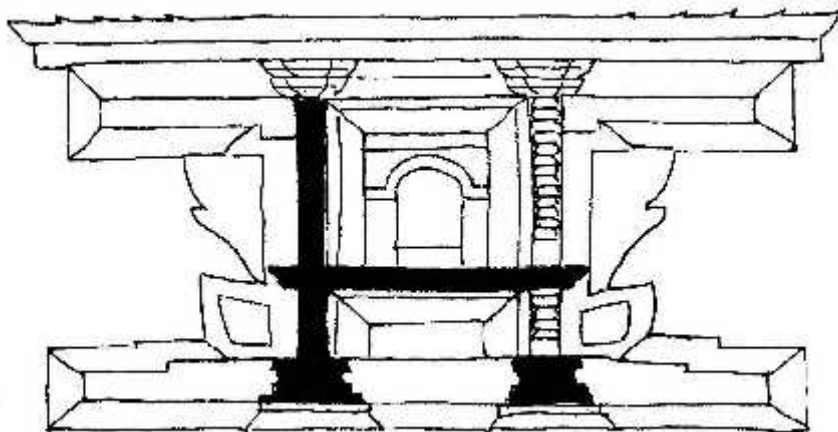

ID No.: B/K 189-WIN(A) 02

Name: Ga Jhya

Monument: Garud Narayan Temple

Size: 75 X 117 cm

Quantity: 1

Material: Wood.

Currently stored at: Nasal Chowk.

Remarks & Recommendations: Remake the lost parts, fix them and reuse the window.

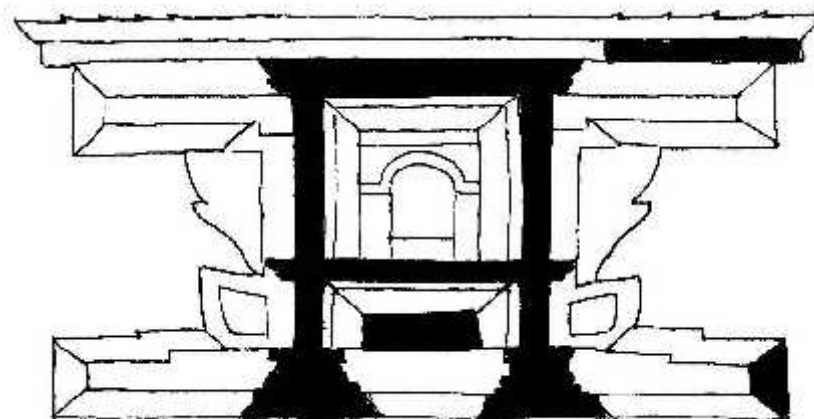

ID No.: B/K 189-WIN(A) 03

Name: Ga Jhya

Monument: Garud Narayan Temple

Size: 75 X 117cm

Quantity: 1

Material: Wood.

Currently stored at: Nasal Chowk.

Remarks & Recommendations: Re-carve the lost part and fix in the structure.

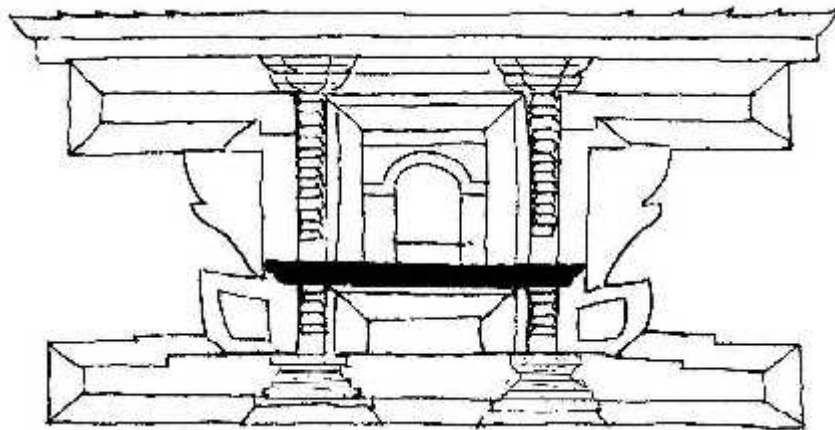

ID No.: B/K 189-WIN(A) 04

Name: Ga Jhya

Monument: Garud Narayan Temple

Size: 75 X 117 cm

Quantity: 1

Material: Wood.

Currently stored at: Nasal Chowk.

Remarks & Recommendations: Re-carve the lost portion and reuse it.

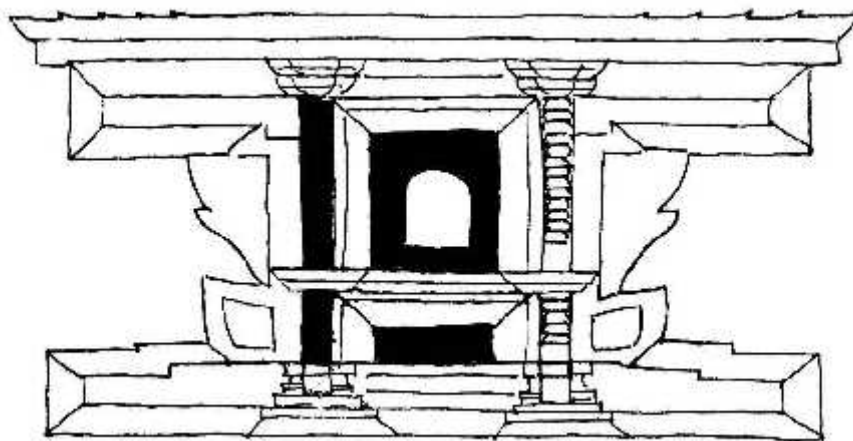

ID No.: B/K 189-WIN(A) 05

Name: Ga Jhya

Monument: Garud Narayan Temple

Size: 75 X 117cm

Quantity: 1

Material: Wood.

Currently stored at: Nasal Chowk.

Remarks & Recommendations: Almost intact. Reuse it.

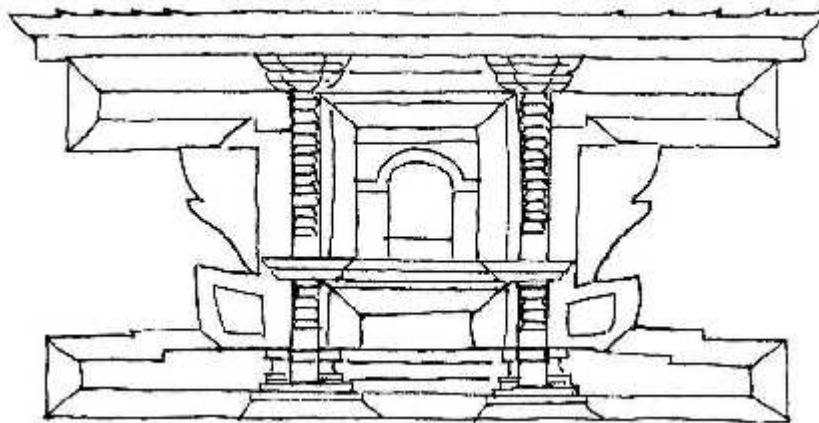

ID No.: B/K 189-WIN(A) 06

Name: Ga Jhya

Monument: Garud Narayan Temple

Size: 75X117cm

Quantity: 1

Material: Wood.

Currently stored at: Nasal Chowk.

Remarks & Recommendations: Remake the lost part then re-fix in the temple.

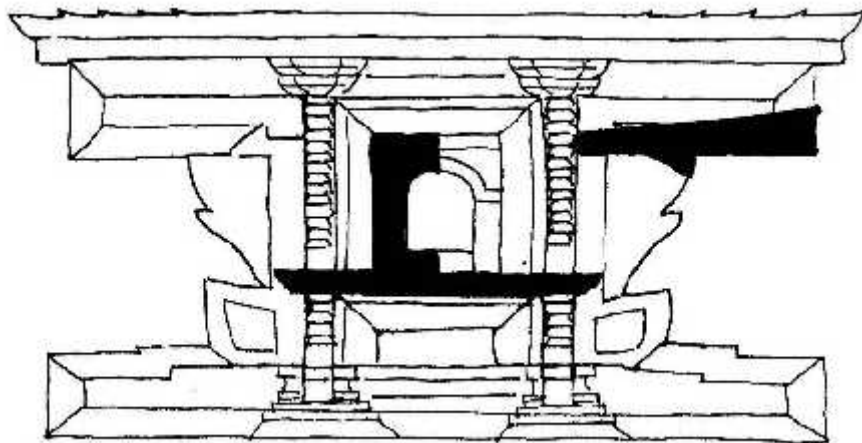

ID No.: B/K 189-WIN(A) 07

Name: Ga Jhya

Monument: Garud Narayan Temple

Size: 75 X 117 cm

Quantity: 1

Material: Wood.

Currently stored at: Nasal Chowk.

Remarks & Recommendations: Remake the lost part then fix in the temple.

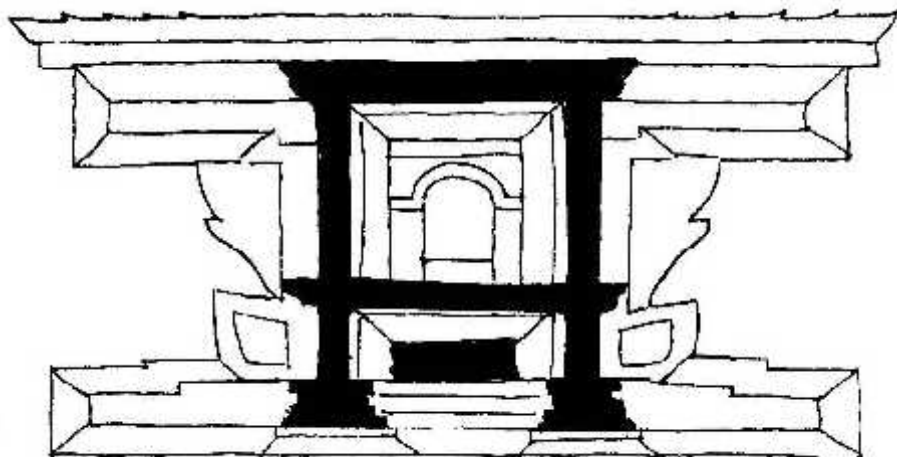

ID No.: B/K 189-WIN(A) 08

Name: Ga Jhya

Monument: Garud Narayan Temple

Size: 75 X 117 cm

Quantity: 1

Material: Wood.

Currently stored at: Nasal Chowk.

Remarks & Recommendations: Remake the lost portion and reuse it.

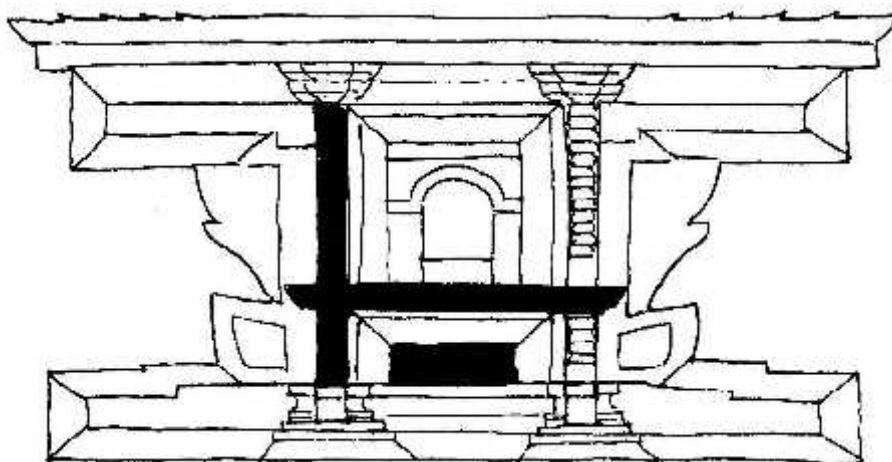

ID No.: B/K 189-WIN(A) 09

Name: Ga Jhya

Monument: Garud Narayan Temple

Size: 75 X 117 cm

Quantity: 1

Material: Wood.

Currently stored at: Nasal Chowk.

Remarks & Recommendations: Remake the lost part then re-fix in the temple.

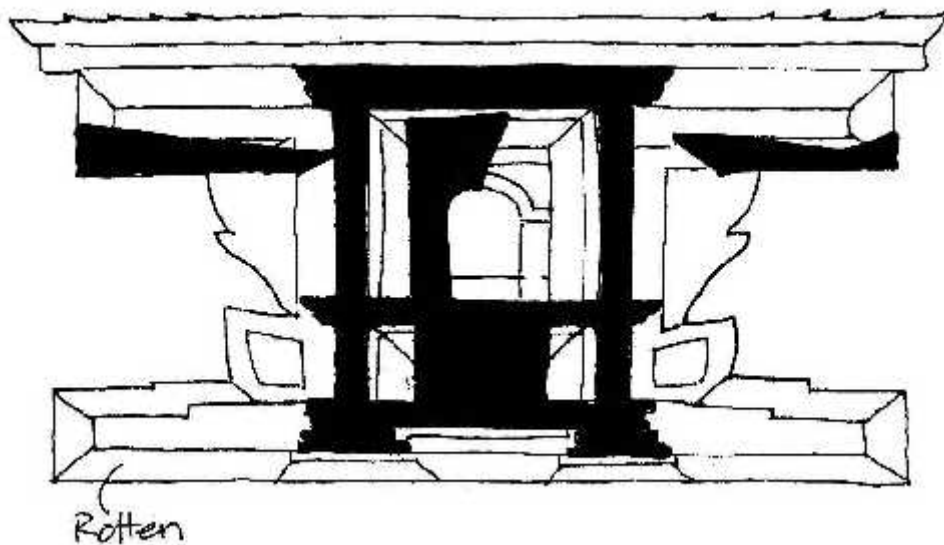

ID No.: B/K 189-WIN(A) 10

Name: Ga Jhya

Monument: Garud Narayan Temple

Size: 75 X 117 cm

Quantity: 1

Material: Wood.

Currently stored at: Nasal Chowk.

Remarks & Recommendations: Fragmented very badly. Remake all lost parts and can be reused all the remaining parts.

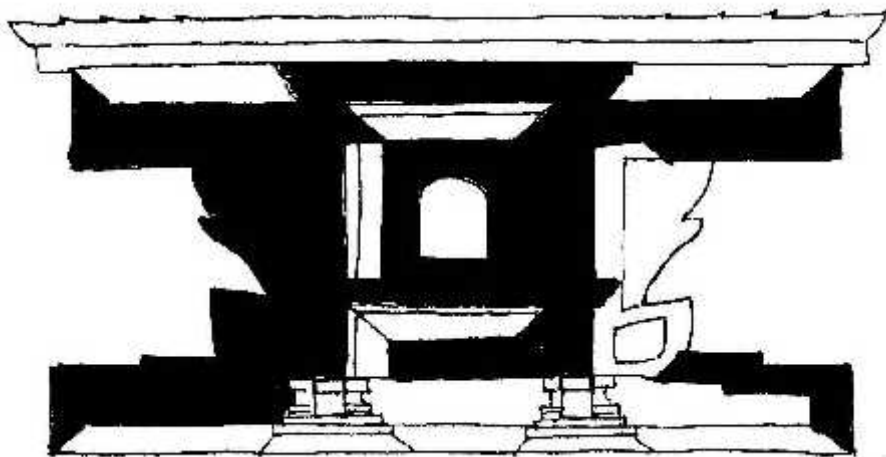

ID No.: B/K 189-WIN(A) 11

Name: Ga Jhya

Monument: Garud Narayan Temple

Size: 75 X 117 cm

Quantity: 1

Material: Wood.

Currently stored at: Nasal Chowk.

Remarks & Recommendations: Remake all the lost portions and make the window complete.

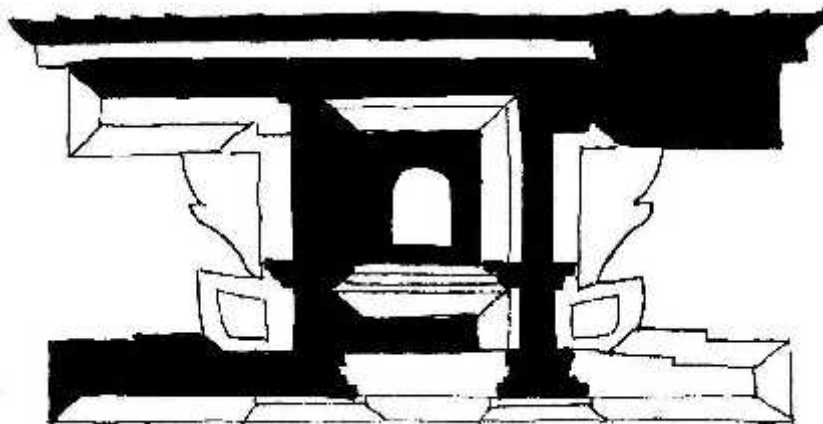

ID No.: B/K 189-WIN(A) 12

Name: Ga Jhya

Monument: Garud Narayan Temple (Ground Floor)

Size: 116 X 183 cm

Quantity: 1

Material: Wood.

Currently stored at: Trishul Chowk.

Remarks & Recommendations: Only small portion is missing. Remake one Tolanthan and fix it to complete the window.

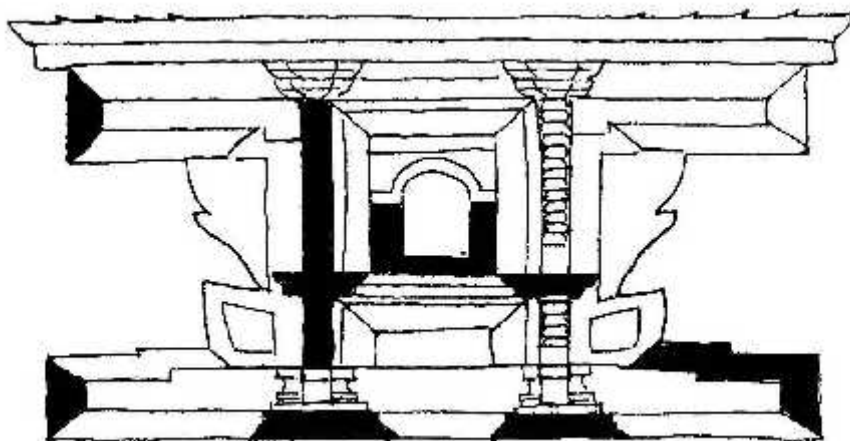

ID No.: B/K 189-WIN(A) 13

Name: Ga Jhya

Monument: Garud Narayan Temple (Ground Floor)

Size: 116 X 183 cm

Quantity: 1

Material: Wood.

Currently stored at: Trishul Chowk.

Remarks & Recommendations: Remake the lost parts and refit it.

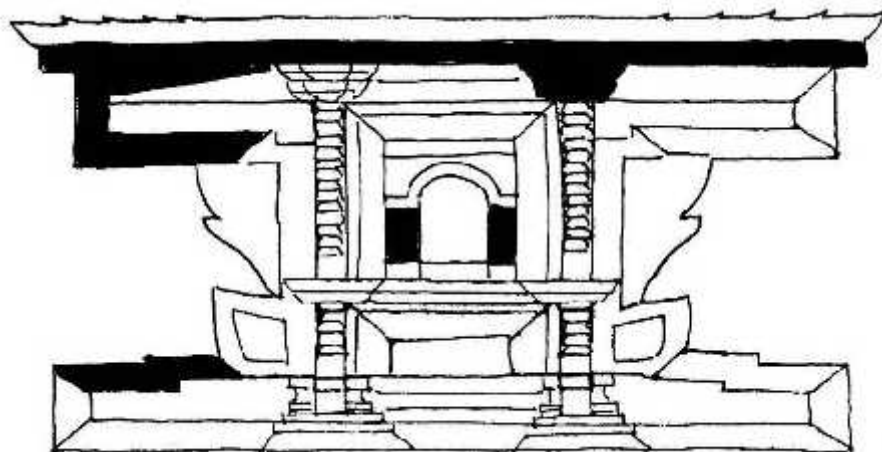

ID No.: B/K 189-WIN(A) 14

Name: Ga Jhya

Monument: Garud Narayan Temple (Ground Floor)

Size: 116 X 183 cm

Quantity: 1

Material: Wood.

Currently stored at: Trishul Chowk.

Remarks & Recommendations: Fragmented many parts and lost. Remake them all to complete the window and then refit it.

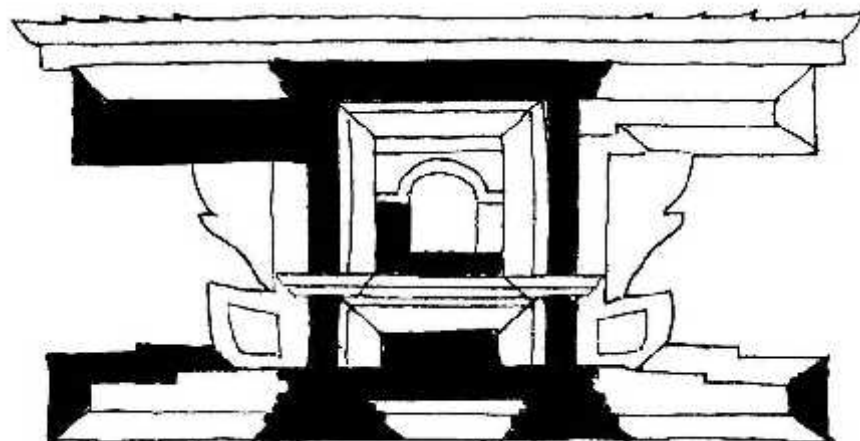

ID No.: B/K 189-WIN(A) 15

Name: Ga Jhya

Monument: Garud Narayan Temple (Ground Floor)

Size: 116 X 183 cm

Quantity: 1

Material: Wood.

Currently stored at: Trishul Chowk.

Remarks & Recommendations: Fragmented too much. However it could be made complete. Then re-fix in the temple.

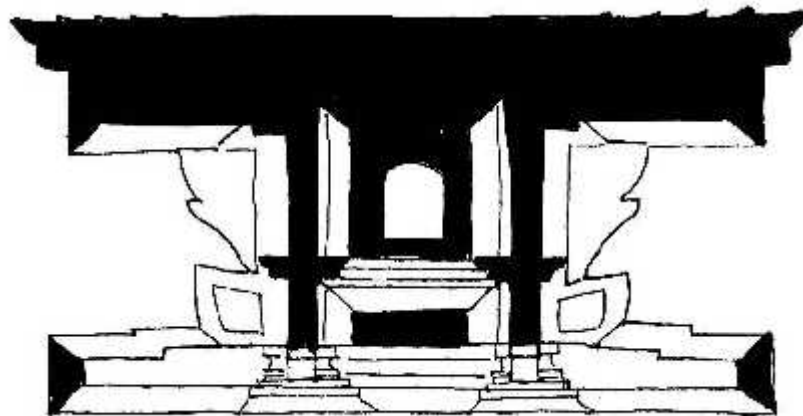

ID No.: B/K 189-WIN(A) 16

Name: Ga Jhya

Monument: Garud Narayan Temple (Middle Storey)

Size: 127 X 187 cm

Quantity: 1

Material: Wood.

Currently stored at: Trishul Chowk.

Remarks & Recommendations: Fill the lost parts making new ones and then refix.

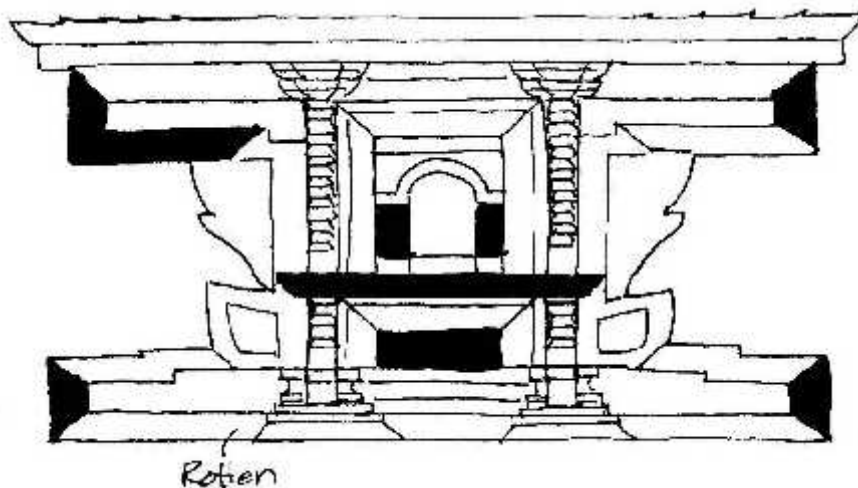

ID No.: B/K 189-WIN(A) 17

Name: Ga Jhya

Monument: Garud Narayan Temple (Middle Storey)

Size: 127 X 187 cm

Quantity: 1

Material: Wood.

Currently stored at: Trishul Chowk.

Remarks & Recommendations: Remake lost parts to complete the window then re-fix in the temple.

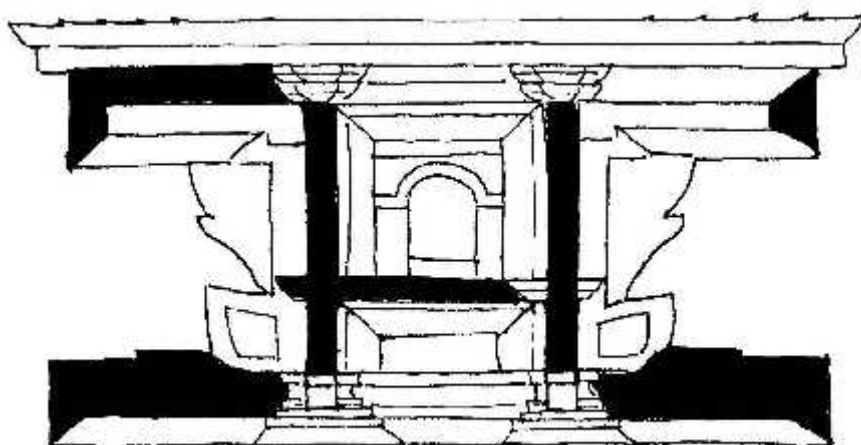

ID No.: B/K 189-WIN(A) 18

Name: Ga Jhya

Monument: Garud Narayan Temple (Middle Storey)

Size: 127 X 187 cm

Quantity: 1

Material: Wood.

Currently stored at: Trishul Chowk.

Remarks & Recommendations: Remake lost parts to complete the window and then use in the temple.

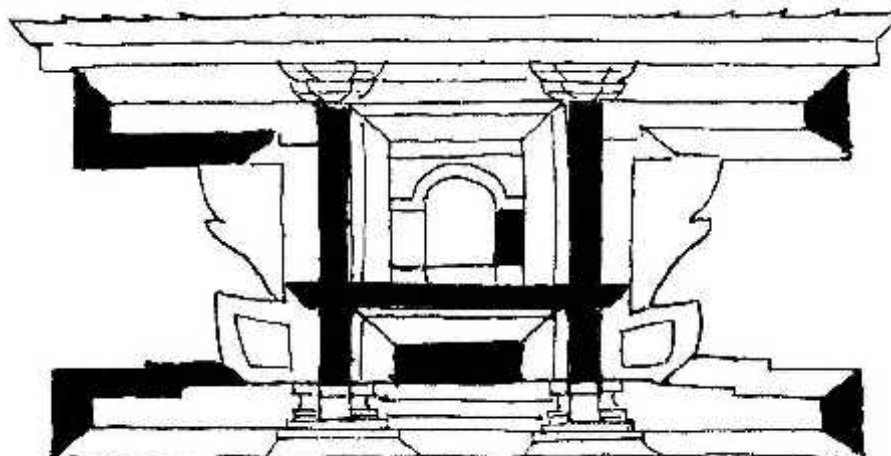

ID No.: B/K 189-WIN(A) 19

Name: Ga Jhya

Monument: Garud Narayan Temple (Middle Storey)

Size: 127 X 187 cm

Quantity: 1

Material: Wood.

Currently stored at: Trishul Chowk.

Remarks & Recommendations: Except two flying lions rest is lost. A new window has have to be made wing at least two parts of older remaining ones.



ID No.: B/K 189-WIN(B) 01

Name: Yaaku Jhya

Monument: Garud Narayan Temple

Size: 62 X 36 cm

Quantity: 1

Material: Wood.

Currently stored at: Shelter 1.

Remarks & Recommendations: Almost intact can be reused directly giving a wash.

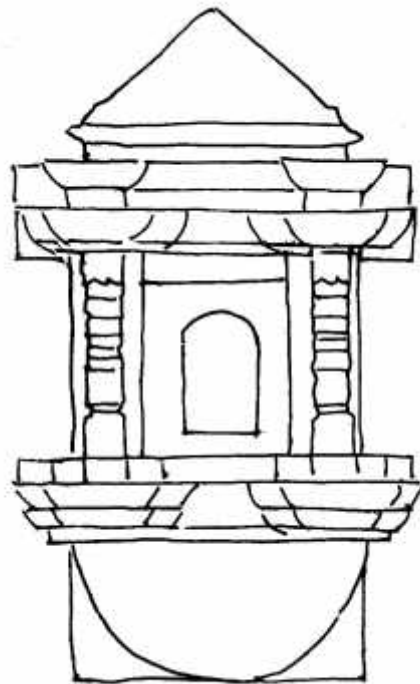

ID No.: B/K 189-WIN(B) 02

Name: Yaaku Jhya

Monument: Garud Narayan Temple

Size: 62 X 36 cm

Quantity:1

Material: Wood.

Currently stored at: Shelter-1

Remarks & Recommendations: Almost intact can be reused directly giving a wash.

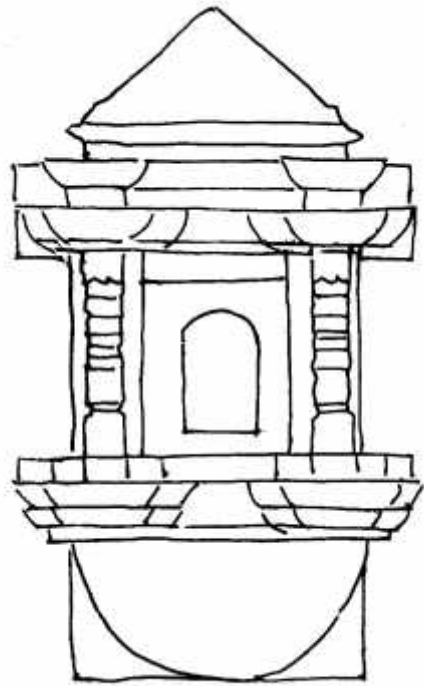

ID No.: B/K 189-WIN(B) 03

Name: Yaaku Jhya

Monument: Garud Narayan Temple

Size: 62 X 36 cm

Quantity: 1

Material: Wood.

Currently stored at: Shelter 1

Remarks & Recommendations: Almost intact can be reused directly giving a wash.

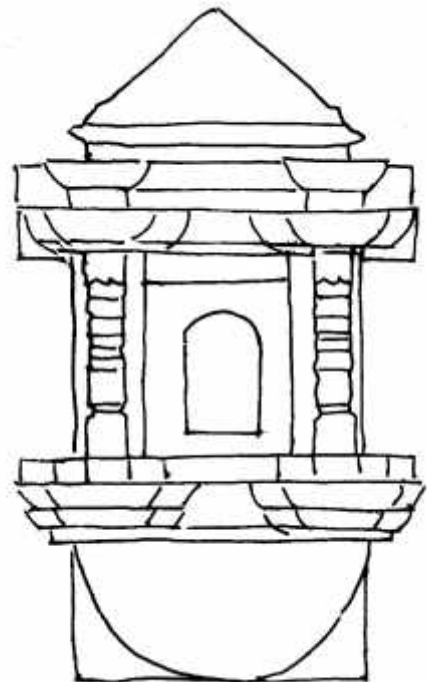

ID No.: B/K 189-WIN(B) 04

Name: Yaaku Jhya

Monument: Garud Narayan Temple

Size: 62 X 36 cm

Quantity: 1

Material: Wood.

Currently stored at: Shelter 1

Remarks & Recommendations: Almost intact can be reused directly giving a wash.

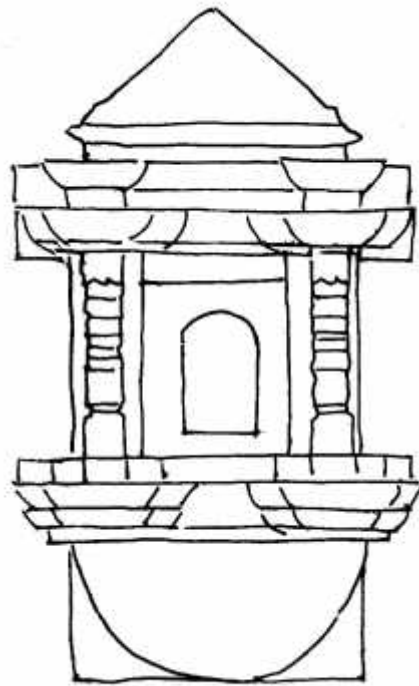

ID No.: B/K 189-WIN(B) 05

Name: Yaaku Jhya

Monument: Garud Narayan Temple

Size: 62 X 36 cm

Quantity: 1

Material: Wood.

Currently stored at: Shelter 1

Remarks & Recommendations: Almost intact can be reused directly giving a wash.

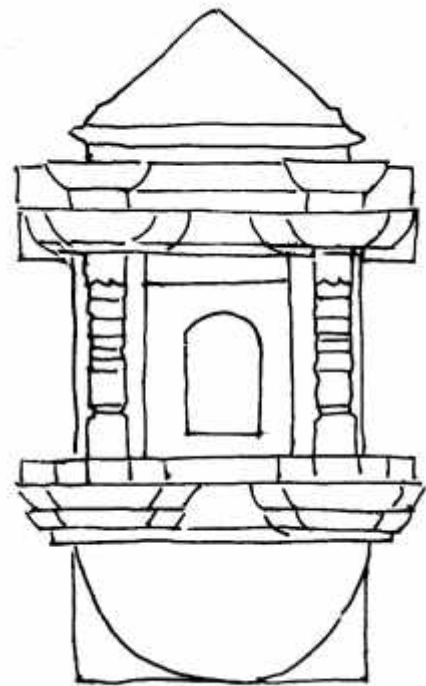

ID No.: B/K 189-WIN(B) 06

Name: Yaaku Jhya

Monument: Garud Narayan Temple

Size: 62 X 36 cm

Quantity: 1

Material: Wood.

Currently stored at: Shelter 1

Remarks & Recommendations: Almost intact can be reused directly giving a wash.

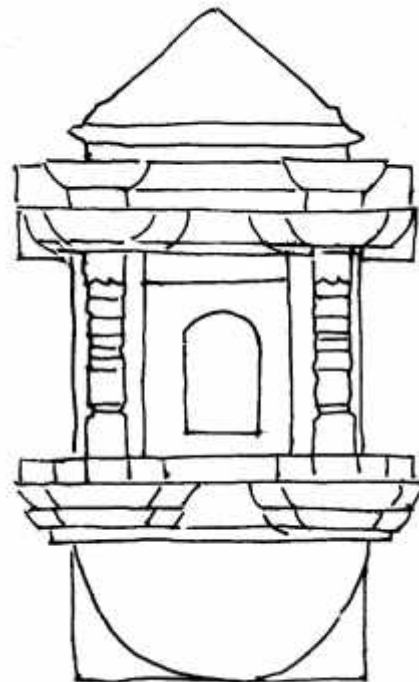

ID No.: B/K 189-WIN(B) 07

Name: Yaaku Jhya

Monument: Garud Narayan Temple

Size: 62 X 36 cm

Quantity: 1

Material: Wood.

Currently stored at: Shelter 1

Remarks & Recommendations: Make new one for bottom part and refix in the Temple.

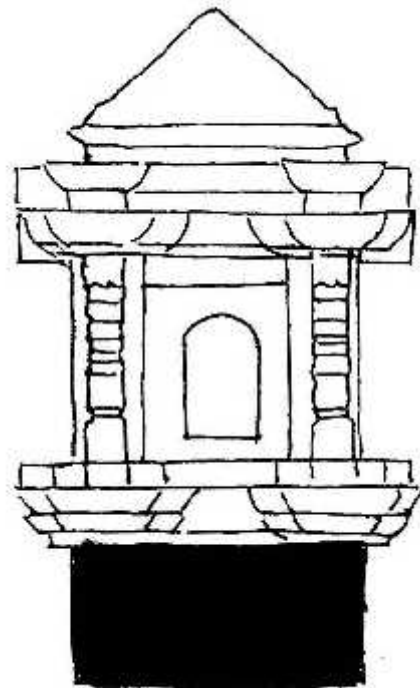

ID No.: B/K 189-WIN(B) 08

Name: Yaaku Jhya

Monument: Garud Narayan Temple

Size: 62 X 36cm

Quantity: 1

Material: Wood.

Currently stored at: Shelter 1

Remarks & Recommendations: Remake the lost parts and reuse it in the temple.

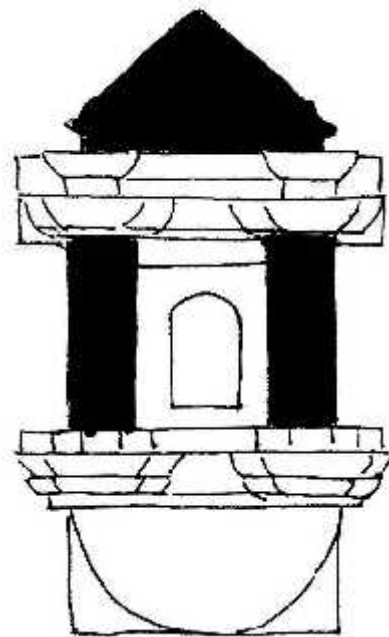

ID No.: B/K 189-Door 01

Name: Door 1

Monument: Garud Narayan Temple

Size: 170 X 275 cm

Quantity: 1

Material: Wood

Currently stored at: Nasal Chowk

Remarks & Recommendation: Reassemble and refit. Fabricate lost or broken pieces.

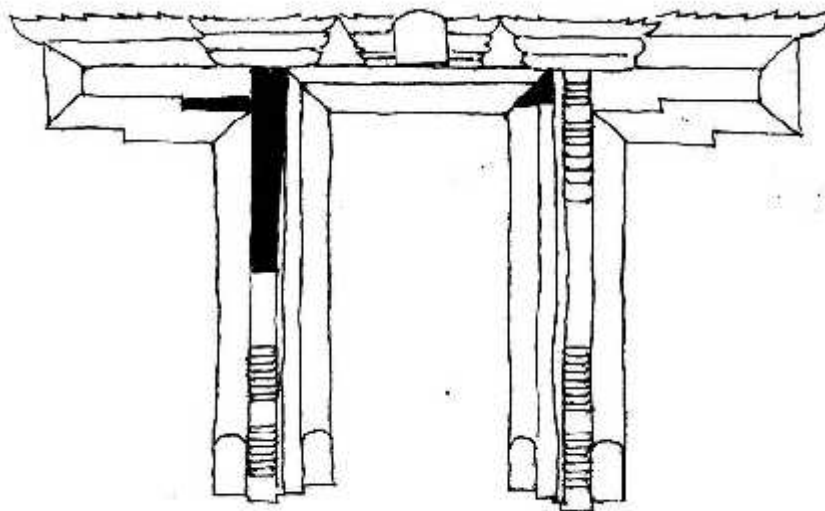

ID No.: B/K 189-Door 02

Name: Door 2

Monument: Garud Narayan Temple

Size: 170 X 275 cm

Quantity: 1

Material: Wood

Currently stored at: Trishul Chowk

Remarks & Recommendation: Reassemble and refit. Fabricate lost or broken pieces.

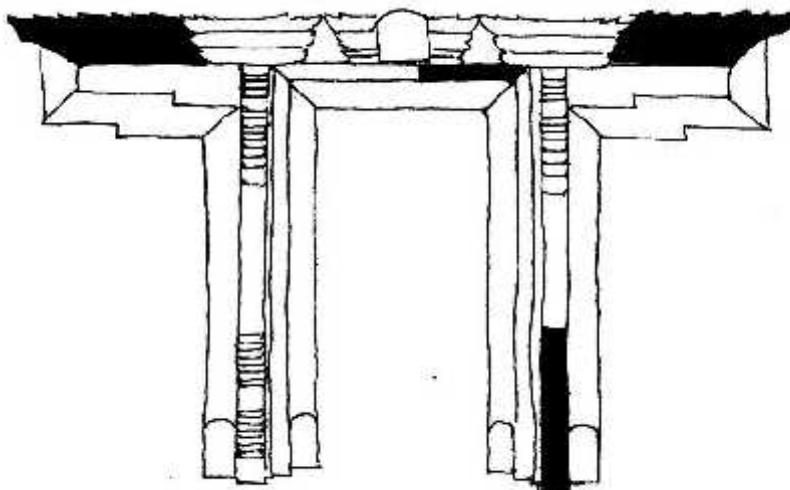

ID No.: B/K 189-Door 03

Name: Door 3

Monument: Garud Narayan Temple

Size: 170 X 275cm

Quantity: 1

Material: Wood

Currently stored at: Trishul Chowk

Remarks & Recommendation: Reassemble and refit. Fabricate lost or broken pieces.

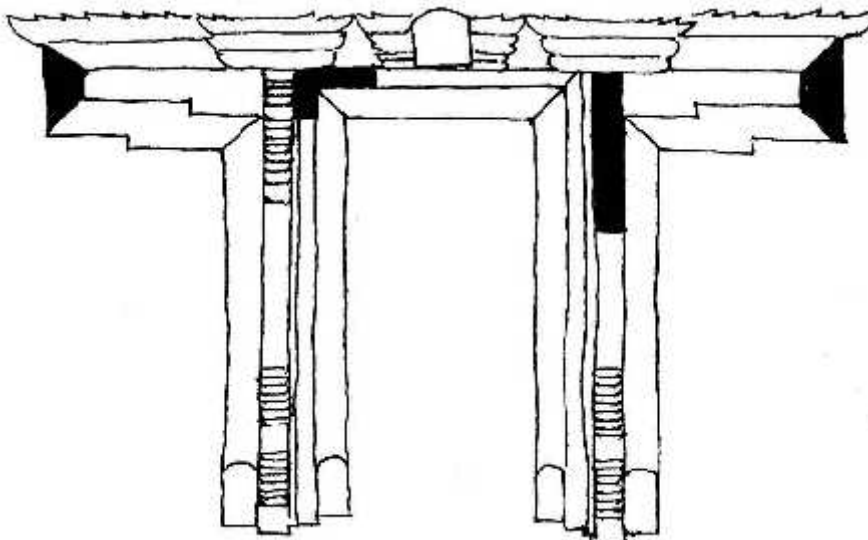

ID No.: B/K 189-Door 04

Name: Door 4

Monument: Garud Narayan Temple

Size: 170 X 275cm

Quantity: 1

Material: Wood

Currently stored at: Trishul Chowk

Remarks & Recommendation: Reassemble and refit. Fabricate lost or broken pieces.

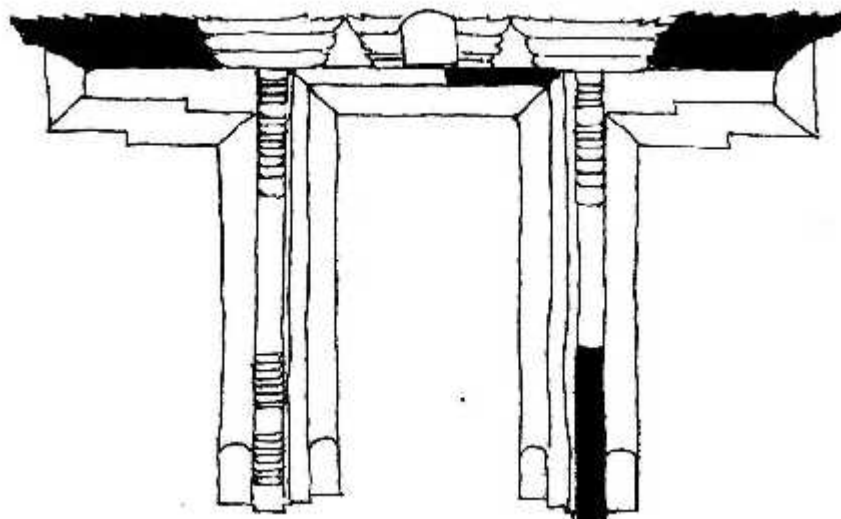

ID No.: B/K 189-Door Panel

Name: Door Panel

Monument: Garud Narayan Temple

Size: 150 X 80 cm

Quantity: 1 (complete) + 1 (partial)

Material: Wood

Currently stored at: Shelter 1

Remarks & Recommendation: 2 are fragmented beyond recovery. Reassemble and refit. Fabricate lost or broken pieces.



ID No.: B/K189-Pillar

Name: Pillar

Monument: GarudNarayan Temple

Size : 176 X 23 X 21cm

Quantity: 16 nos.

Material: Wood

Currently stored at: Nasal Chowk

Remarks & Recommendation: Make the tenons and refit.



ID No.: B/K189-Meth

Name: Meth (Bracket)

Monument: GarudNarayan Temple

Size : 128 X 19 cm (full meth), 92 X 19 cm (half meth)

Quantity: 8 nos. each

Material: Wood

Currently stored at: Shelter 1

Remarks & Recommendation: Mostly reusable. Few needs to be rebuilt.



ID No.: B/K189-CH

Name: Chakulaan

Monument: Garud Narayan Temple

Size : 33 X 33 cm

Quantity: 8 pcs.

Material: Wood

Currently stored at: Shelter 1

Remarks & Recommendation: Needs
extensive repair to be reused.



ID No.: B/K189-Dh

Name: Dhalinkhwa

Monument: Garud Narayan Temple

Size :

Quantity: More than 100 nos.

Material: Wood

Currently stored at: Shelter 1

Remarks & Recommendation: Almost all of those recovered are in good condition. Few may need repair.



ID No.: B/K189-ICON01

Name: Garud Narayan

Monument: Garud Narayan Temple

Size. : 55 X 73 cm.

Quantity: 1

Material: Stone

Currently stored at: Nhulachhen Chowk

Remarks & Recommendation: The image is broken at various places. As the broken images should not be worshipped in practice, this broken images should be replicated anew and the old one to be transferred to museum for display.



ID No.: B/K189-DECO

Name: Decorative Piece

Monument: Garud Narayan Temple

Size : (Varies)

Quantity: 7 nos. of individual variety

Material: Wood

Currently stored at: Shelter 1

Remarks & Recommendation: Mostly reusable. Few needs to be repaired/rebuilt.



SHIVA TEMPLE (C/K-155)

01. Struts

02. Kunsala

03. Windows

04. Doors

05. Miscellaneous

ID No.: C/K 155 – TDL 01

Name: Ardhanarisvara Shiva (Androgynous)

Monument: Shiva Temple (Lower Storey)

Size: 137 X 21.5 X 10 cm

Quantity: 1

Material: Wood

Currently stored at: Shelter 1

Remarks & Recommendations: Both hands are broken off.
Though looks in good condition, due to thin nature of the
body it needs to be reinforced.



ID No.: C/K 155 – TDL 02

Name: A male Shaivite Deity (a form of Shiva) Might be
Vamadeva?

Monument: Shiva Temple (Lower Storey)

Size: 134.5 X 19 X 10 cm

Quantity: 1

Material: Wood

Currently stored at: Shelter 1

Remarks & Recommendations: (Good) Half the body (chest
part) has flaked off. But could be replaced with partial
carving done by skilled hand is recommended. Left portion
of the full strut is insect eaten. Should be reused only after
reinforcement. One pedestal has a unique figure with a long
walking stick. It was damaged during the earthquake of
2015.



ID No.: C/K 155 – TDL 03

Name: A figure of river Ganges in Salabhanjika

Monument: Shiva Temple (Lower Storey)

Size: 136 X 21.5 X 10 cm

Quantity: 1

Material: Wood

Currently stored at: Shelter 1

Remarks & Recommendations: Major part of the left leg, feet and thigh is flaked off leaving small portion of calf. Both hands are gone. Also left portion of entire strut is insect eaten and eroding. The strut should be chemically cleaned, washed and treated. Then can be reused with reinforced support.

P.S. This piece could be of 15 or 16th century.



ID No.: C/K 155 – TDL 04

Name: Jattamukuta

Monument: Shiva Temple (Lower Storey)

Size: 134.5 X 20 X 10 cm

Quantity: 1

Material: Wood

Currently stored at: Shelter-

Remarks & Recommendations: Both hands are gone. Rest is somehow in good condition. The upper portion of this strut depicts monkeys, one playing its own organ and the other offering some fruit. The deity as in all figures is standing cross legged upon a double pestle lotus, below which are a pair of bull. The lowest portion depict four figures two of whom are male and two female. One male is embracing two female and the male in far left corner is enticing a female who is also embraced by a male, damaged.



ID No.: C/K 155 – TDL 05

Name: Mahesh

Monument: Shiva Temple

Size: 137 X 2 X 10 cm

Quantity: 1

Material: Wood

Currently stored at: Shelter

Remarks & Recommendations: The strut is relatively safe but time erosion is noticed. All hands are gone.

Reinforcement is recommended however.



ID No.: C/K 155 – TDL 06

Name:

Monument: Shiva Temple.

Size: 137 X 20 X 10 cm

Quantity: 1

Material: Wood

Currently stored at: Shelter 1

Remarks & Recommendations: A form of Shiva, 4 armed. Vertically broken, the lower half also damaged. Below is a scene being enticed by a lady on top monkeys and Vidhyadhar playing. Most eroded climatically and physical condition as well. Since the piece is too fragile is recommended to carve new one and send it to the museum for display



ID No.: C/K 155 – TDL 07

Name: A Shaivite figure of Shiva.

Monument: Shiva Temple (Lower Storey - West)

Size: 137 X 23 X 10 cm

Quantity: 1

Material: Wood

Currently stored at: Shelter 1

Remarks & Recommendations: Top portion is damaged with water percolation. Middle part with the main figure is cracked. Time factor has eaten away in life. However this is master piece among many struts. Can be reused but with much care and well reinforcement. The back support is essential.



ID No.: C/K 155 – TDL 08

Name: A divinity Figure.

Monument: Shiva Temple (Lower Storey)

Size: 141 X 21.5 X 11.5 cm

Quantity: 1

Material: Wood

Currently stored at: Shelter 1

Remarks & Recommendations: This is the most newest copy probably replaced in 1960s renovation. Can be reused directly.



ID No.: C/K 155 – TDL 09

Name: A Shaivite divine figure.

Monument: Shiva Temple, Upper roof strut.

Size: 90 X 15 X 7.5 cm

Quantity: 1

Material: Wood

Currently stored at: Shelter 1

Remarks & Recommendations: Can be reused directly.



ID No.: C/K 155 – TDL 10

Name: Female deity.

Monument: Shiva Temple (Upper Storey)

Size: 91.5 X 15 X 7.5 cm

Quantity: 1

Material: Wood

Currently stored at: Shelter 1

Remarks & Recommendations: Good can be reused.



ID No.: C/K 155 – TDL 11

Name: Female deity.

Monument: Shiva Temple, Upper roof strut.

Size: 93 X 15 X 7.5 cm

Quantity: 1

Material: Wood

Currently stored at: Shelter 1

Remarks & Recommendations: Good Out of eight upper roof struts, only seven are left, one is lost. All of the seven struts are safe enough and strong as well, therefore could be reused after some cleaning.



ID No.: C/K 155 – TDL 12

Name: Female deity.

Monument: Shiva Temple, upper roof strut.

Size: 91.5 X 15 X 7.5 cm

Quantity: 1

Material: Wood

Currently stored at: Shelter 1

Remarks & Recommendations: Good Out of eight upper roof struts, only seven are left, one is lost. All of the seven struts are safe enough and strong as well, therefore could be reused after some cleaning.



ID No.: C/K 155 – TDL 13

Name: Female deity.

Monument: Shiva Temple, upper roof strut.

Size: 91.5 X 15 X 7.5 cm

Quantity: 1

Material: Wood

Currently stored at: Shelter 1

Remarks & Recommendations: Can be reused directly.



ID No.: C/K 155 – TDL 14

Name: Female deity.

Monument: Shiva Temple, Upper roof strut.

Size: 93 X 15 X 7.5 cm

Quantity: 1

Material: Wood

Currently stored at: Shelter 1

Remarks & Recommendations: Good Out of eight upper roof struts, only seven are left, one is lost. All of the seven struts are safe enough and strong as well, therefore could be reused after some cleaning.



ID No.: C/K 155 – TDL 15

Name: Female deity.

Monument: Shiva Temple, upper roof strut.

Size: 91.5 X 15 X 7.5 cm

Quantity: 1

Material: Wood

Currently stored at: Shelter 1

Remarks & Recommendations: Good Out of eight upper roof struts, only seven are left, one is lost. All of the seven struts are safe enough and strong as well, therefore could be reused after some cleaning.



ID No.: C/K 155 – K 01

Name: Kunsala (Corner Strut)

Monument: Shiva Temple, lower storey.

Size: 173 X 15 X 19 cm

Quantity: 1

Material: Wood

Currently stored at: Shelter 1

Remarks & Recommendations: Half the portion till the mouth from top is cracked. In totality the condition is still good for reuse with minor strengthening in the head portion to tie with a knot bolt and give a wash.



ID No.: C/K 155 – K 02

Name: Kunsala (Corner Strut)

Monument: Shiva Temple/Lower storey.

Size: 172 X 14 X 20 cm

Quantity: 1

Material: Wood

Currently stored at: Shelter 1

Remarks & Recommendations: The top of the phallic portion is gone. Rest is still intact except the head portion has small crack in the chick. The phallic tip should be replaced with new carving, rest is still intact to reuse.



ID No.: C/K 155 – K 03

Name: Kunsala (Corner Strut)

Monument: Shiva Temple/lower storey

Size: 176 X 19 X 18 cm

Quantity: 1

Material: Wood

Currently stored at: Shelter 1

Remarks & Recommendations: Only private part is broken out. Rest is still intact. Give a small wash and could be reused with minor strengthening.



ID No.: C/K 155 – K 04

Name: Kunsala (Corner Strut)

Monument: Shiva Temple/lower storey

Size: 174.5 X 13 X 18 cm

Quantity: 1

Material: Wood

Currently stored at: Shelter 1

Remarks & Recommendations: Still in good condition with minor rot on top. Can be reused with minor wash back of the neck is to be reinforced to enhance the strength.



ID No.: C/K 155 – K 05

Name: Kunsala (Corner Strut)

Monument: Shiva Temple (Upper Storey)

Size: 109 X 9.5 X 13 cm

Quantity:1

Material: Wood

Currently stored at: Shelter 1

Remarks & Recommendations: Good .These four are
new and can be reused directly.



ID No.: C/K 155 – K 06

Name: Kunsala (Corner Strut)

Monument: Shiva Temple (Upper storey)

Size: 113 X 10 X 11.5 cm

Quantity:1

Material: Wood

Currently stored at: Shelter 1

Remarks & Recommendations: Good .These four are
new and can be reused directly.



ID No.: C/K 155 – K 07

Name: Kunsala (Corner Strut)

Monument: Shiva Temple/upper storey

Size: 113 X 10 X 13 cm

Quantity:1

Material: Wood

Currently stored at: Shelter 1

Remarks & Recommendations: Good .These four
are new and can be reused directly.



ID No.: C/K 155 – K 08

Name: Kunsala (Corner Strut)

Monument: Shiva Temple (Upper Storey)

Size: 109 X 10 X 13 cm

Quantity:1

Material: Wood

Currently stored at: Shelter 1

Remarks & Recommendations: Good .These four
are new and can be reused directly.



ID No.: C/K 155 – WIN (A) 01

Name: Gaa: Jhya

Monument: Shiva Temple

Size: 110 X 160 X 36 cm

Quantity: 1

Material: Wood

Currently stored at: Southern plinth of Taleju Temple.

Remarks & Recommendations: The window is still reusable with one addition of small pieces of Kotah also seen in the picture. Kotah to be replaced with carved plank copying from another window.

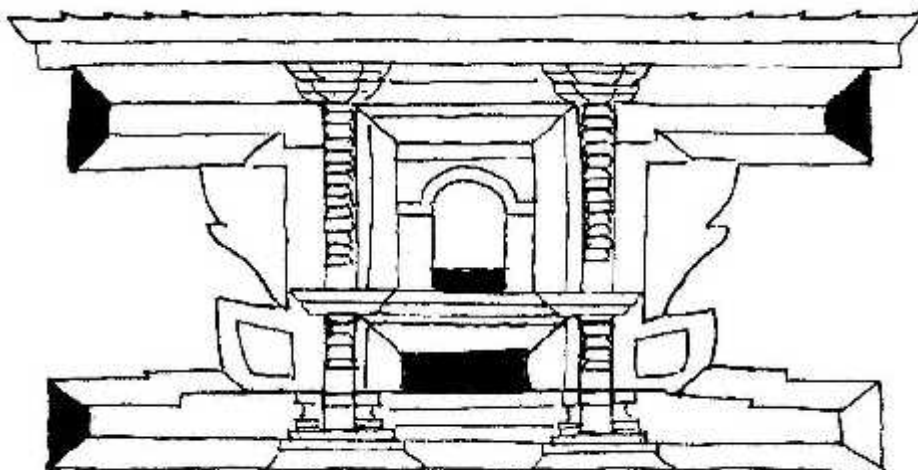

ID No.: C/K 155 – WIN (A) 02

Name: Gaa: Jhya

Monument: Shiva Temple

Size: 110 X 160 X 36 cm

Quantity: 1

Material: Wood

Currently stored at: Southern plinth of Taleju Temple.

Remarks & Recommendations: A small piece in the opening is broken. Except that everything is almost intact therefore could be reused. A small piece of arch is broken off. This portion is to be re-carved and attached to.

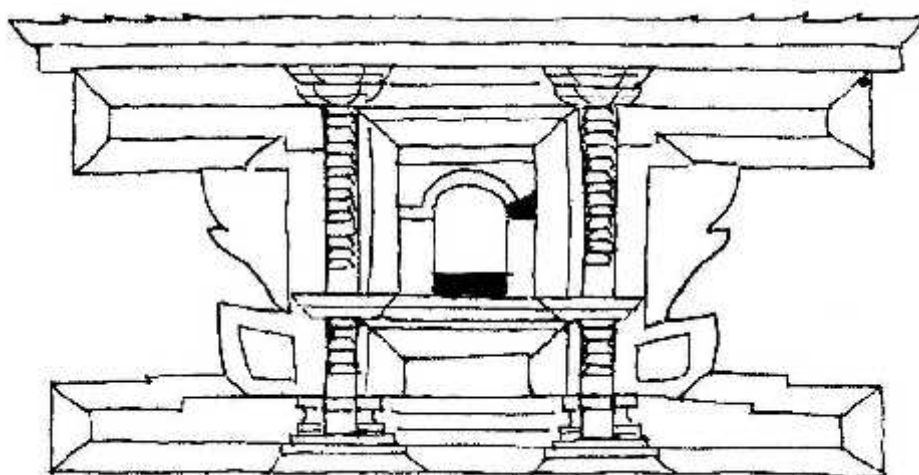

ID No.: C/K 155 – WIN (A) 03

Name: Gaa: Jhya

Monument: Shiva Temple.

Size: 110 X 160 X 36 cm

Quantity: 1

Material: Wood

Currently stored at: Southern plinth of Taleju Temple

Remarks & Recommendations: Kotah has to be replaced with carved plank copying from another window and the base beam has to be replaced.

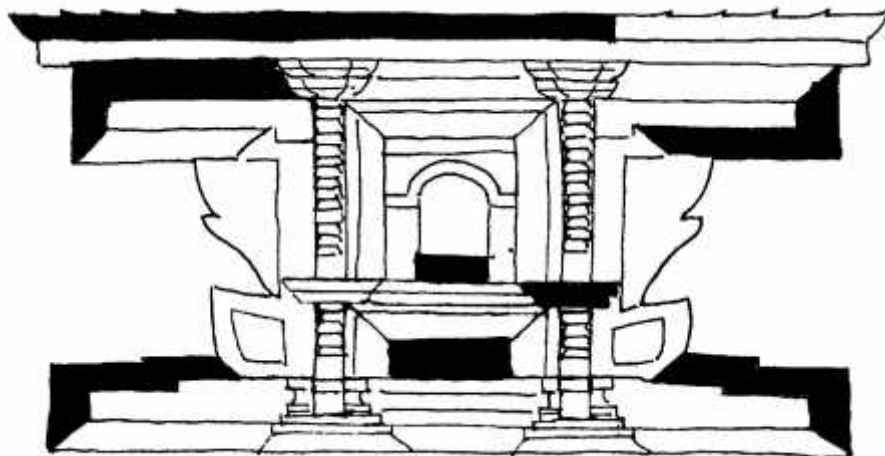

ID No.: C/K 155 – WIN (A) 04

Name: Gaa: Jhya.

Monument: Shiva Temple.

Size: 110 X 160 X 36 cm

Quantity: 1

Material: Wood

Currently stored at: Southern plinth of Taleju Temple

Remarks & Recommendations: Arch of the window (inside) portion has to be partially added. Two third of the top and complete base beam should be replaced.

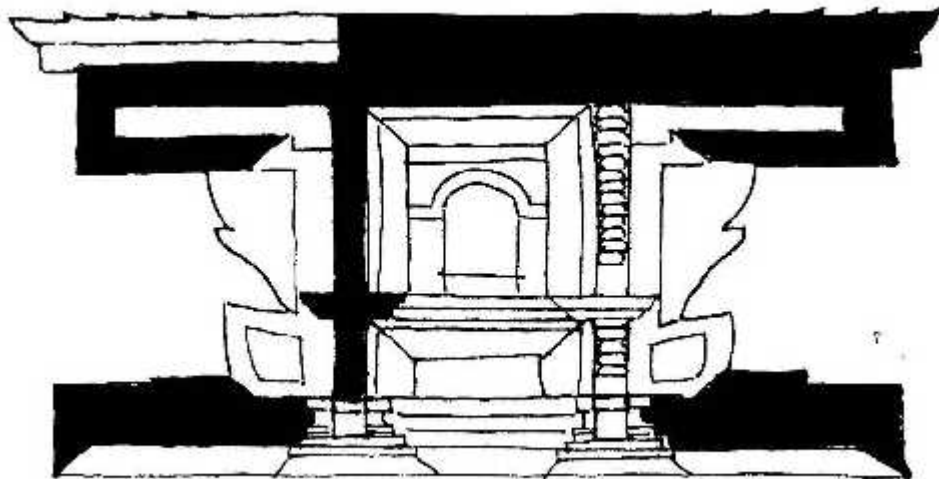

ID No.: C/K 155 – WIN (A) 05

Name: Gaa: Jhya

Monument: Shiva Temple.

Size: 68 X 107 X 22 cm

Quantity:

Material: Wood

Currently stored at: Southern plinth of Taleju Temple.

Remarks & Recommendations: Central portion of the window is to be tightened with addition of some pieces and *kotah* portion also should be replaced with the carved plate.

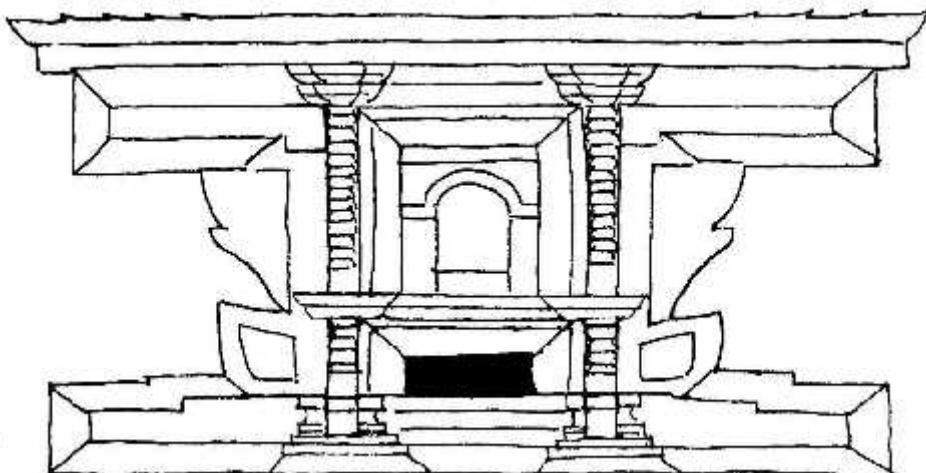

ID No.: C/K 155 – WIN (A) 06

Name: Gaa: Jhya

Monument: Shiva Temple

Size: 68 X 107 X 22 cm

Quantity: 1

Material: Wood

Currently stored at: Southern plinth of Taleju Temple.

Remarks & Recommendations: The base beam has to be mended in left portion and replacement of the Kotah plate should be replaced with carved plate.

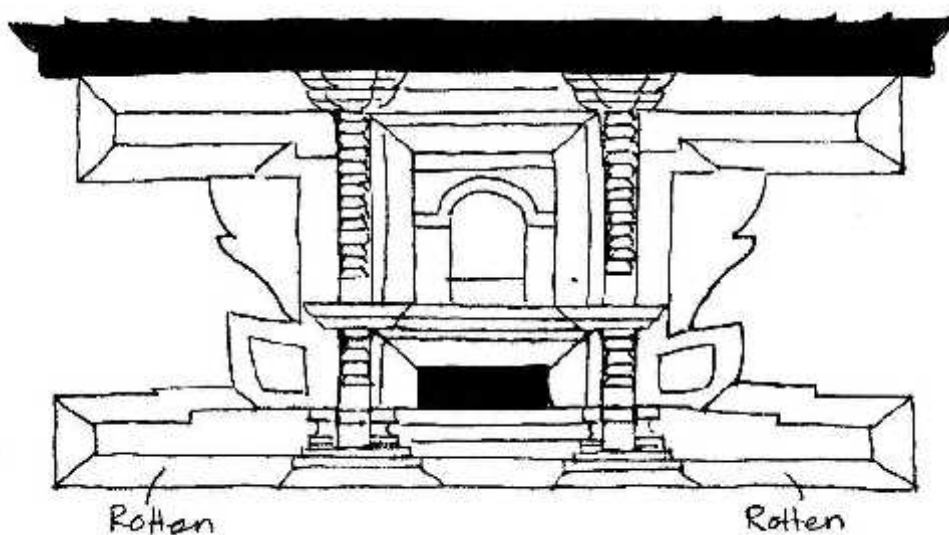

ID No.: C/K 155 – WIN (A) 07

Name: Gaa: Jhya

Monument: Shiva Temple.

Size: 68 X 107 X 22 cm

Quantity: 1

Material: Wood

Currently stored at: Southern plinth of Taleju Temple.

Remarks & Recommendations: God is missing in it. Kotah portion and base plate $\frac{1}{2}$ have to be replaced. Kotah portion as in S.T. 001 has to be replaced with carved plate and base beam should be.

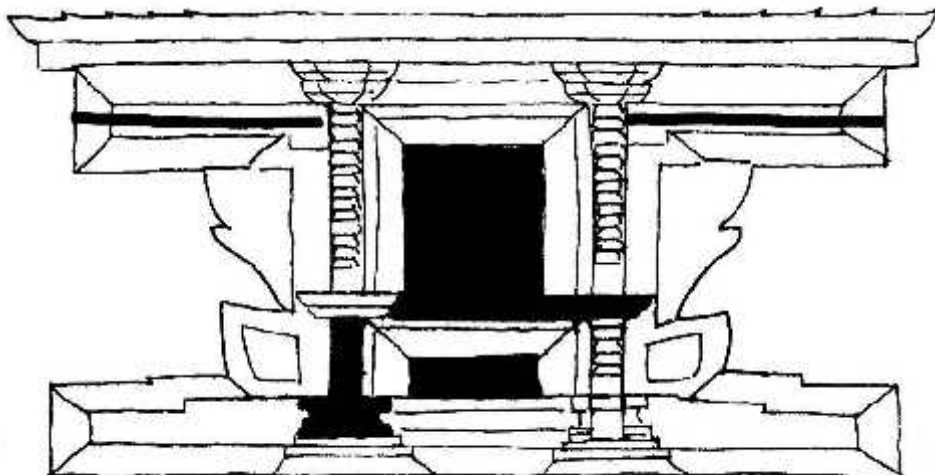

ID No.: C/K 155 – WIN (A) 08

Name: Gaa: Jhya

Monument: Shiva Temple.

Size: 68 X 107 X 22 cm

Quantity: 1

Material: Wood

Currently stored at: Southern plinth of Taleju Temple.

Remarks & Recommendations: Good. Retightening is enough.

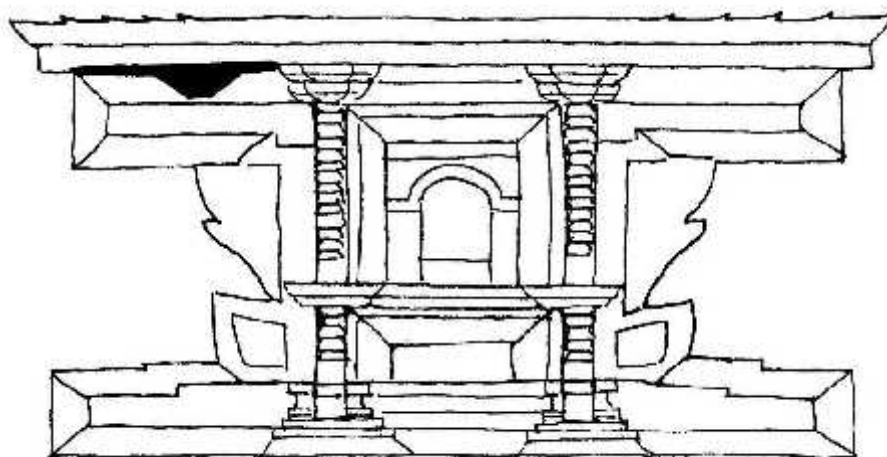

ID No.: C/K 155 – Door

Name: Shiva Temple Door.

Monument: Shiva Temple.

Size: 127 X 234 X 28 cm (only door portion)

Quantity: 1

Material: Wood

Currently stored at: On the plinth of Taleju Temple.

Remarks & Recommendations: 65% of the carved portions are still in good condition for reuse though they are eroded. 35% have to be re-carved. Yaakubaha one has to be re-carved, one is still reusable after re-strengthening.



ID No.: Miscellaneous

Name: Shiva Temple Cornice portion.

Monument: Shiva Temple.

Size: Various

Quantity: 61 pieces of dhalinkhvas in total.

Material: Wood

Currently stored at: Southern plinth of Taleju Temple.

Remarks & Recommendations: This is the complete set of cornice horizontal in Shiva Temple, but partial part only. Total recovered 61 pieces, 20 not usable, 41 can be reused. Total of 61 pieces of dhalinkhvas were recovered. Among them 20 pieces are not usable remaining 41 pieces can be reused.

Total recovered pieces.

Khichawa: 35 feet

Dhalinkhvas: 41 pcs. (Reusable)

Nagbeli: 30 feet.

Palepho: 24 feet.

(In order from top to bottom)



ID No.: Miscellaneous

Name: Central Chaukos of upper roof
made of plain timber.

Monument: Shiva Temple.

Size: Various.

Quantity:

Material: Wood

Currently stored at: Plinth of Taleju Temple.

Remarks & Recommendations: Good. Can be directly reused.

P.S. all 61 pieces of dhalinkhas are stored in this covered with tarpaulin.



ID No.: Miscellaneous

Name: Sardula and Singha face of dhalinkhwaa

Monument: Shiva Temple.

Size: 10 X 12 cm X length varies.

Quantity: 61 pieces

Material: Wood

Currently stored at: Plinth of Taleju Temple.

Remarks & Recommendations: Good.

Can be reused after wash.





Pun Dega, Maju Dega and Narayan Temple (After Earthquake)