

The Truck Driver's Guide

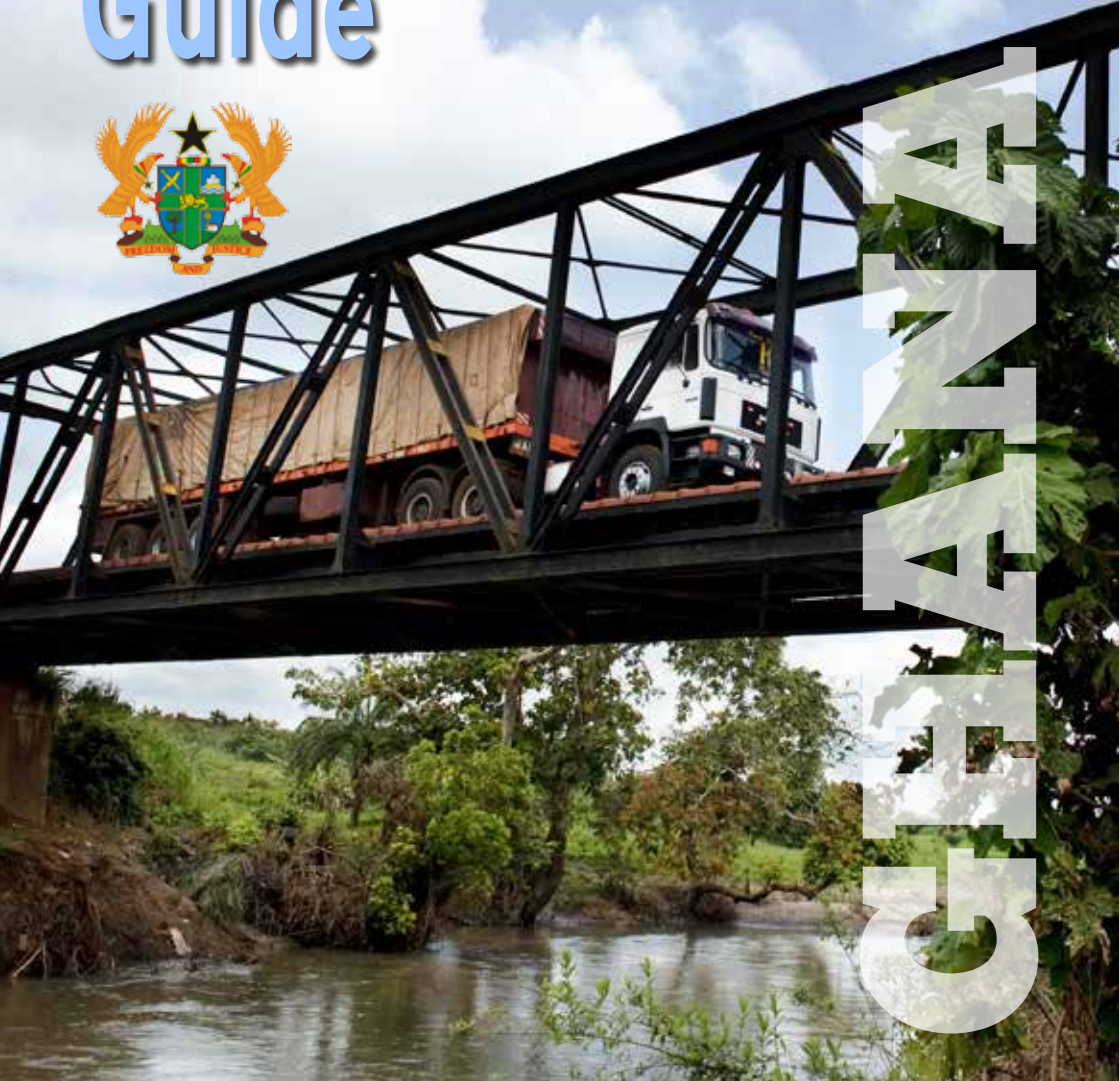

W
A
N
A
F
O
U
R

BORDER  **ESS**

Removing trade barriers in West Africa





CONTENTS

Introduction	3
Road Rules	4
Speed Limits for General Vehicles	
Speed Limits for Commercial Vehicles Carrying Freight	
Required Safety Equipment	
Vehicle Measurements Limits	
Maximum Driving Periods	
Regulations for Foreign Drivers	
What the Police do to Ensure Road Safety	
Common Offences and Penalties for Violations	
Incidents on the Road	8
Procedures to Follow Immediately After an Accident	
In Case of Breakdowns	
Towing	
Checkpoints	12
Police Checkpoints	
Customs Checkpoints	
Immigration Checkpoints	
Other Services at Checkpoints	
Axle Load Restrictions	
Allowable Maximum Gross Weight of Vehicles	
What Happens at Weighbridges?	
Weighbridge Locations	
Getting help	16
For Complaints About Uniformed Officers	
Ghana Police Services	
Customs Division of the Ghana Revenue Authority	
Complaints about Activities at Weighbridges	
Assistance for Bonds Issued by SIC	
For Information about Regional Shippers' Councils	
Burkina Shippers' Council (CBC)	
Entrepôts Malien au Ghana (EMAGHA)	
Niger Shippers' Council in Ghana (CNUT)	
Ghana Shippers' Authority	
Police Regional Headquarters	
Where to get more information	18
The National Road Safety Commission (NRSC)	
The Ghana Police Service (GPS)	
The Ghana Highway Authority (GHA)	
Customs Division of the Ghana Revenue Authority	
Ghana Ports & Harbours Authority	
Ghana Immigration Service (GIS)	
SIC Insurance Company Ltd. (SIC)	
Veterinary Services Directorate (VSD)	
Plant Protection and Regulatory Services Directorate (PPRSD)	
ECOWAS Brown Card Insurance Scheme	





INTRODUCTION

Ghana is the gateway to West Africa and welcomes your business! As a driver, you need to know what the laws say and how the rules are implemented by uniformed services along the route. This guide presents the most important information about Ghana's traffic laws and enforcement.

It includes:

- The rules for using Ghana's roads and highways
- How customs and police officers enforce the law
- What to do in case of an accident
- What documents you must carry
- The new axle-load rules
- Telephone numbers to call when you need help

Ghana's roads and highways carry hundreds of thousands of tonnes of cargo from ports to destinations across the region every day. Uniformed services protect and serve the millions of people using the routes. Facilitating the efficient and low-cost movement of goods and passengers makes Ghana an ideal place to do business and reflects ECOWAS' vision for free movement of people, goods and transport.

Ghana's National Road Transport and Transit Facilitation Committee has prepared this document to improve awareness of the laws and regulations. Violations can lead to accidents – every driver has a responsibility to know and respect the laws.

We hope your travels along Ghana's roads and highways are stress-free and safe!

Honorable
Minister for Transport

Honorable
Minister for Roads and Highways

For more information about this guide or its contents contact Ghana's National Road Transport and Transit Facilitation Committee Secretariat at +233 302 671 445.



ROAD RULES

Ghana's traffic laws protect the public's safety and facilitate the smooth and efficient movement of people and goods. This section presents some of the important laws, information about how the police enforce them and penalties for violating common laws.

Speed Limits for General Vehicles

Unless otherwise indicated, the following limits in kilometers per hour (km/h) should be observed.

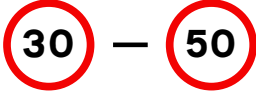

Urban Areas



Highways



Motorways

Speed Limits for Commercial Vehicles Carrying Freight



Loaded Trucks



Empty Trucks

Required Safety Equipment

General

- Two standard advance warning triangles
- First aid box with basic components
- Fire extinguisher (6 kg in weight for trucks and recharged after every six months)
- Spare tyre in good condition
- Reflectors (Red L shaped at the rear, and white in front)
- Lamps (white or yellow light visible from a reasonable distance)

For trucks and trailers

- All trucks require two red and white diagonally striped retro reflectors
- All trailers require trailer lights
- Trucks weighing 3.5 MT or more must have reflective tape (yellow in color and 50 mm wide) on the side and back of the truck and trailer.
- Trailers carrying loads exceeding 2.5 m wide or 4.5 m high require a special permit and drivers should contact the Road Safety Department of the Ghana Highway Authority on 030 266 6592.



Vehicle Measurements Limits

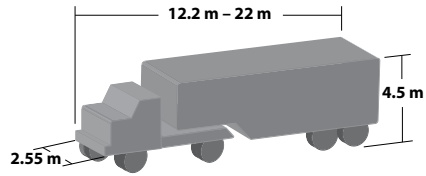
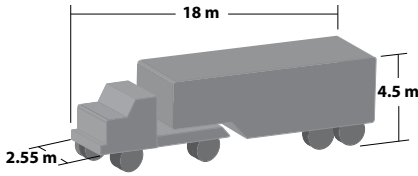

Maximum Driving Periods

Ghanaian law prohibits driving for more than four hours at a time. When driving long distances, drivers should take frequent stops of at least 30 minutes to stay alert. Within any 24 hour period, drivers are restricted from driving more than eight hours or 500 km whichever comes first. When taking breaks, long-distance drivers are encouraged to sleep on comfortable cots within tents to ensure a restful break free from mosquitoes.



Regulations for Foreign Drivers

Foreign cargo vehicles entering Ghana must obtain a temporary importation permit. Customs issues this document, called a "laissez passer/C59," at the border. The permit is valid for 30 days. If it expires, drivers must return with the vehicle to the same border entry to renew it. The maximum renewal period that may be granted is 90 days.

Customs require drivers to produce the following documents in order to process the C59 form:

- An international driver's licence
- ECOWAS Brown Card

For problems with processing the C59 or in the case of renewals of, please call the please call the Customs Head Office at 030 266 6841.



What the Police do to Ensure Road Safety

The Ghana Police Service derives its source of authority and functions from the Fourth Republican Constitution of Ghana. The Ghana Police Service through the motor Traffic and Transport Unit basically enforces all traffic rules and regulations, including the Road Traffic Act (2004), Act 683, as amended by the Road Traffic (Amendment) Act, 2008, Act 761 and Road Traffic Regulation 2012, L.I. 2180.

Most often, all the Traffic Law Enforcement Officers (the MTU) wear white tunic with black trousers and distinctive caps. All officers of the MTU officer wear specific badges with their names and numbers inscribed on them. They authorized to;

- Control and manage traffic
- Enforce rules and regulation by arresting and prosecuting all traffic offenders.
- Investigate all traffic accident cases reported.
- Conduct patrols on Ghana's major roads with the view to reducing road traffic accidents

Drivers have the right to report the misconduct of an officer in uniform to the Police Intelligence and Professional Standards Bureau (PIPS) unit of the Ghana Police Service (see page 14). The report should include the officer's badge number and rank on his/her uniform.

Common Offences and Penalties for Violations

Please note this list is not exhaustive. For full details of all road offences and penalties, please refer to the Road Traffic Act, 2004 (Act 683) , the Road Traffic Regulations, 1974, and their amendments.

MINOR DRIVING OFFENCES (ROAD TRAFFIC REGULATION 2012, LI 2180)	FINES
Refusal to renew road use certificate	60 -300 GHC
Refusal to register number plates	60 -300 GHC
Renewal of registration number plates	120 -300 GHC
False entry in Trade License log book	120 GHC
Learner driver to be accompanied by an experienced driver	60 GHC
Failure to renew driving license	120 – 300 GHC
Disqualification of Under Aged Persons	120 GHC
Non-conformity to restrictions on width and length of vehicles	300 GHC
Non-conformity to restrictions on vehicle height	300 GHC
Non- conformity to restriction on carriage of loads	120 GHC
Offences and penalties for LPG fitted vehicles	120-300 GHC
Mirror, Windscreen & glass	60 GHC
Use of unspecified tinted glass	300-600, 120-600 GHC
Failure to carry fire extinguisher	120 – 300 GHC



MINOR DRIVING OFFENCES

(ROAD TRAFFIC REGULATION 2012, LI 2180)

FINES

Non-conformity with restrictions on Horns and Sirens	300 GHC
Driving motor vehicles without reflectors (front and back)	60 GHC
Failure to carry advance warning devices	300 – 600 GHC
Failure to wear reflective clothing and protective helmet	300 – 600 GHC
Non-compliance with regulation on carriage of persons and goods	600 GHC
Driving on the shoulder of a road	120-600 GHC
Prohibition on use of Communication Device	600 GHC
Non-compliance with maximum driving periods	300 GHC
Failure to use seat belts	120- 600 GHC
Operating commercial vehicle without a commercial vehicle driving permit	300 GHC
Prohibition of use of motorcycle or tricycle for commercial passenger services	300 GHC
Non-compliance with regulation on speed limiters , logbooks and tachographs	300 GHC
Exceeding the prescribed number of persons to be carried	120 – 300 GHC
Particulars to be written on commercial vehicles	60 GHC
Failure to comply with regulations on visitors driving permit	240-300 GHS
Use of Foreign Drivers' license	240 – 300 GHC
Non-compliance with the rules of the road	120 – 300 GHC
A person being an excess passenger on a vehicle	60 GHC
Non-compliance with regulations on speed limits	60 GHC
Obedience to police and fire service officials	120 GHC
Obstructing intersections and pedestrian crossings	120 – 300 GHC
Disregarding signs and barricades	60 GHC
Stopping and Parking if buses and taxis regulated	120-300 GHC
Parking in highway and town road	120 -300 GHC

MAJOR DRIVING OFFENCE**FINES**

Dangerous driving	600 GH¢ and/or 7 years imprisonment
Careless and inconsiderate driving	2,400 GH¢ and/or up to 3 years 4 months imprisonment
Driving under the influence of alcohol	2,400 GH¢ and/or up to 3 years 4 months imprisonment



INCIDENTS ON THE ROAD

Even when drivers obey the laws and drive vehicles in good condition, accidents happen. Other issues arise. This section presents information on how to handle such issues.

Procedures to Follow Immediately After an Accident

In case of an accident

- Switch off the engine to prevent fire outbreak
- Display a warning triangle to warn other drivers and also prevent another accident.
- Inform the nearest police station as soon as possible. Give specific location, 191 or 18555 and assist in the conduct of investigations.
- Inform the nearest fire service, especially if people are trapped or vehicle is carrying inflammable goods.
- Foreign drivers should report the accident immediately to the ECOWAS Brown Card secretariat in Ghana (contact details of the ECOWAS Brown Card office are found on the back page of the ECOWAS Brown card booklet) and provide the following details:
 - Date of Incident
 - Name of Insured
 - Name of Insurer
 - Country
- If visiting the ECOWAS Brown Card secretariat in person, provide a copy of the Brown Card. (The ECOWAS Brown Card secretariat will contact the National Bureau in the driver's country to seek confirmation of the Brown Card coverage. Once there is confirmation, the secretariat will provide a letter to the police requesting the release of the vehicle documents to the driver or owner to enable him to go about his normal business.)

When parking alongside any road, drivers are required to place reflective triangles 45 m in front of and 45 m behind their trucks.

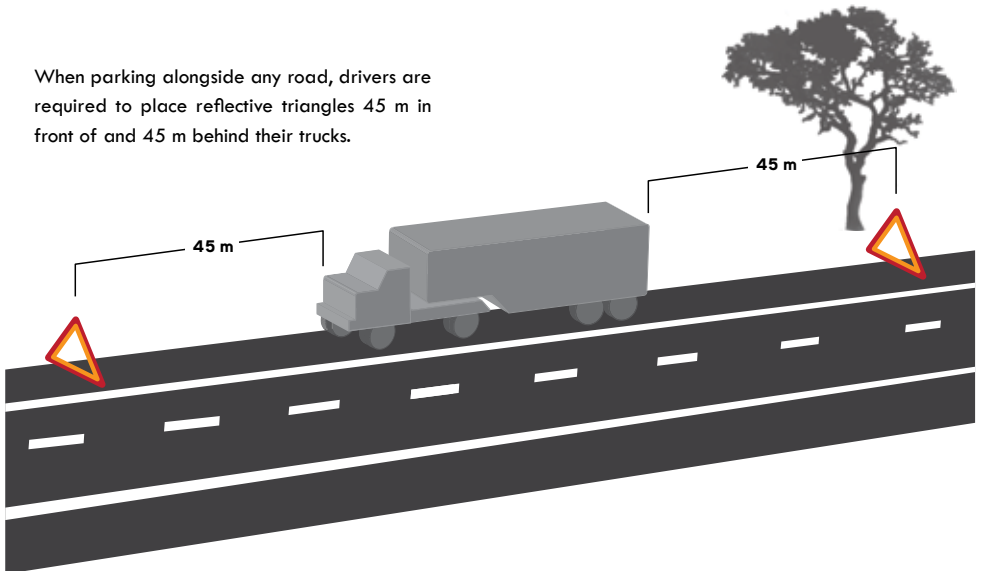

In Case of Breakdowns

After a breakdown drivers should:

- Move the vehicle to a location where it will not obstruct the free flow of traffic, as soon as possible.
- Place reflective triangles 45 m in front of and behind the vehicle to warn approaching drivers.
- If the broken down vehicle is expected to obstruct traffic for more than 1 hour in an urban area, or more than 2 hours in a rural area, the driver must leave his name, number and address at the nearest police station.





Towing

Dial +233 for Ghana

If your truck has broken down and you need a towing service, find out which region you are in and contact the Road Safety Management Services Limited. Also notify the closest police headquarters. If the driver fails to remove his vehicle within this period, the authorities will tow the vehicle away and the driver will have to pay for the towing cost.

ROAD SAFETY MANAGEMENT SERVICES LIMITED

Tel: 0244 335139 ; 0244 335140

info@roadsafetyservice.org

www.roadsafetyservices.org

Regional Contacts

- **Greater Accra Region** 020-208-8291
- **Eastern Region** 020-849-4521
- **Western Region** 020-208-8286
- **Central Region** 020-208-8282
- **Volta Region** 020-208-8289
- **Ashanti Region** 020-208-8285
- **Northern Region** 020-6748972
- **Upper East Region** 020-3407503
- **Upper West Region** 020-833-1740
- **Brong Ahafo Region** 020-208-8287



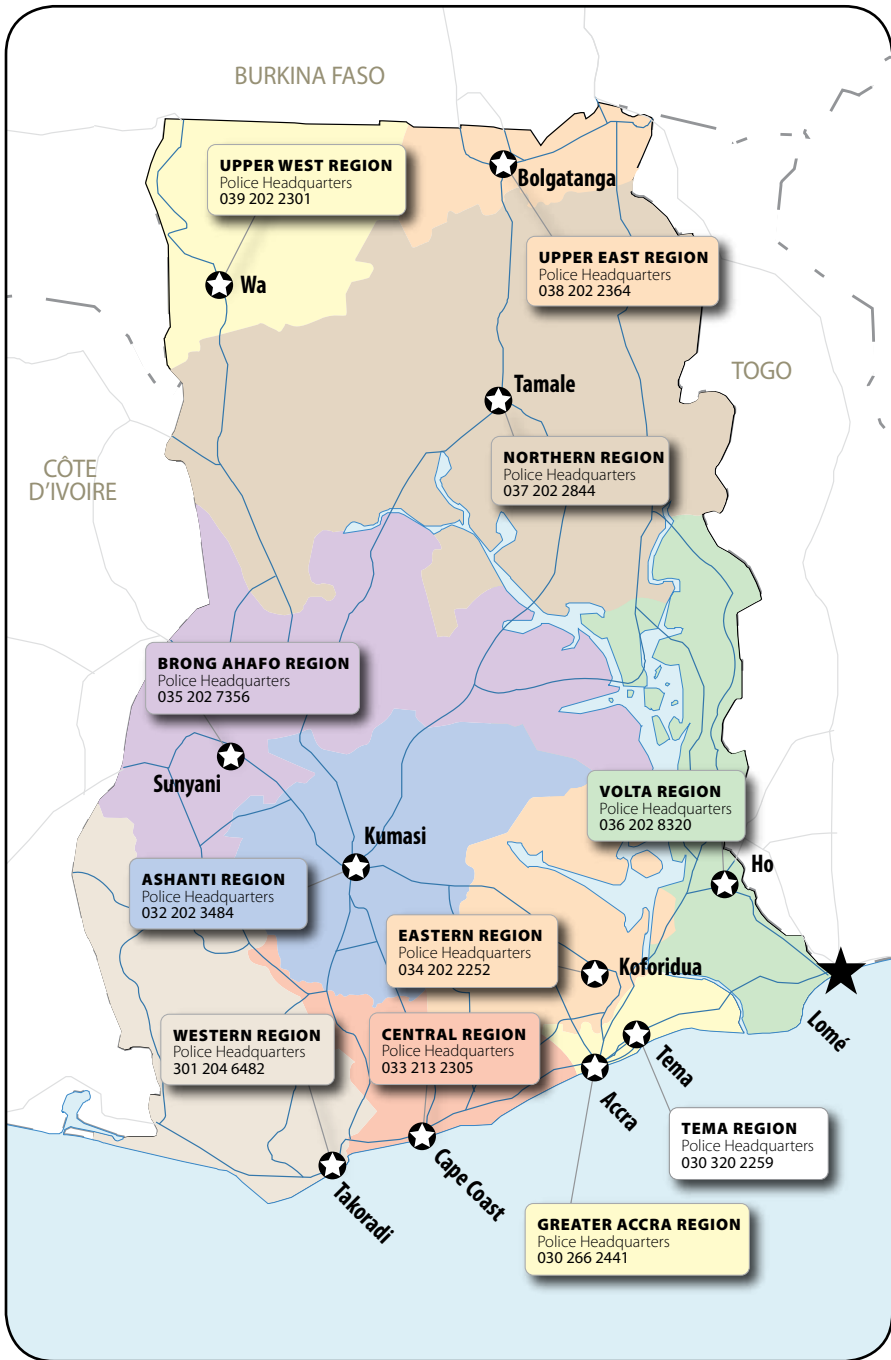

Incidents on the Road





CHECKPOINTS

Ghana Police Service, Immigration and CEPS operate fixed and mobile checkpoints to guard against road crime and enforce customs and immigration laws.

Police Checkpoints

At authorised checkpoints the police may check any of the following documents:

- International Driver's Licence
- International Driver's Permit
- National ID Card/Passport
- International Green Card
- ECOWAS Brown Card
- Roadworthiness Certificate

Customs Checkpoints

On duty customs officers patrol transit corridors checking for prohibited or restricted goods and verify if transit cargo has relevant customs certification and documentation such as:

- Inter-State Road Transit Logbook (ECOWAS ISRT Logbook)
- Inter-State Waybill
- Customs Declaration
- Letter of Guarantee (for imported vehicles)

In case these documents are not available Customs have the right to impound the vehicle until proper documentation is provided.

Immigration Checkpoints

At inland and international border posts immigration officials may check any of the following valid travel documents:

- Passport
- International Driver's Licence

Other Services at Checkpoints

Other government agencies also check trucks and their cargo at checkpoints:

Forestry:

- Log Measurement Conveyance Certificate (LMCC)
- Form C (Property Mark)
- Waybill from the seller
- VAT Receipt

Ghana Health Services:

- International Yellow Card

Ghana Sanitary Phytosanitary & Zoosanitary Services:











- Quality Certificate (for exports)



Axle Load Restrictions

Overloaded trucks are dangerous and destroy roads. In June 2009, Ghana began implementing regional axle load restrictions. Member states aim to fully implement ECOWAS and UEMOA axle load limits in 2014.

Allowable Maximum Gross Weight of Vehicles

AUTHORIZED TOTAL WEIGHT OF SOME COMMON VEHICLES					
	VEHICLE	ATLW			
1	Vehicle with 2 axes (9 ; 12) P11 	18 tonnes	2		
			Vehicle with 3 axes, one of which is type tandem type4 (9 ;23) P12 	26 tonnes	
3	Vehicle with 4 axes, one of which is tridem type 2 (9 ;27), P13 	31 tonnes	3b		
			Vehicle with 4 axes, one of which is tandem type 2 (9 ; 12; 23) P112 	31 tonnes	
4	Trailer with 2 axle (9 ; 12) R11 	18 tonnes	5		
			Trailer with three axes, one of which is a tandem (9 ;23) R12 	26 tonnes	
VEHICLE		PTRA	VEHICLE		PTRA
6	Articulated vehicle with 3 axes (9 ; 12 ; 12t) T11S1 	30 tonnes	7	Articulated vehicle with 4 axes, one of which is tandem type 4 (9 ; 12 ; 23t) T11S2 or (9 ; 23 ; 12), T12S1 	38 tonnes
8	Articulated vehicle with 5 axes, one of which is tridem type 2. (9 ; 12 ; 27t), T11S3 	43 tonnes	9	Articulated vehicle with 5 axes, two of which are tandem type 4 (9 ;23 ;23t) T12S2 	46 tonnes
10	Articulated Vehicle with 6 axes, with 1 tandem type 4 and 1 tridem type 2 (9 ;23 ;27) T12S3 Six axle or more vehicle 	51 tonnes			



What Happens at Weighbridges?

Private companies operate weighbridges under the supervision of Ghana Highway Authority (GHA) officials with police officers to enforce the laws. Trucks must stop at all weighbridge stations. Drivers who refuse to stop face a 300 GH¢ fine and/or 8 months' imprisonment.

Upon entering a weighbridge, a police officer signals a truck to stop. A GHA official will weigh the truck and provide a printout showing the recorded weight. If a truck is overweight (see weight chart, page 13) the official will collect the original logbook and waybill, copy them and return them to the driver. Overloaded trucks can be detained until fines are paid and, in some instances, the truck driver will be required at his own expense to shed any excess weight to meet axle load restrictions before continuing.

Trucks within permissible weight limits do not have to pay at the weighbridge.

The truck operator/driver should always know the tare weight of his empty truck and check it periodically – especially after the truck undergoes maintenance – in order to know the allowable weight of cargo to load. Empty trucks can be weighed at no charge at any of the GHA weighbridges.

Weighbridge locations in Ghana are shown in the map on page 15.

Weighbridge Locations

Weighing points for trucks travelling between:

- **Tema to Paga**
**Tema Motorway, Dobro, near Nsawam, Offinso and Bolgatanga.*
- **Paga to Tema**
Bolgatanga, Yapei, Offinso and Boankra
- **Aflao to Elubo**
Akatsi, Tema Motorway, Elmina and Agona Junction.
- **Kumasi to Gonokrom**
Asuoyeboah
- **Takoradi to Kumasi**
Agona Junction, Bogoso

Mobile weigh vans may also be located along the corridor for monitoring purposes.

* Only trucks respecting weight limits are allowed to enter the Tema motorway



WEIGHBRIDGE PROGRAMME

Permanent Weighbridge Stations and Platforms

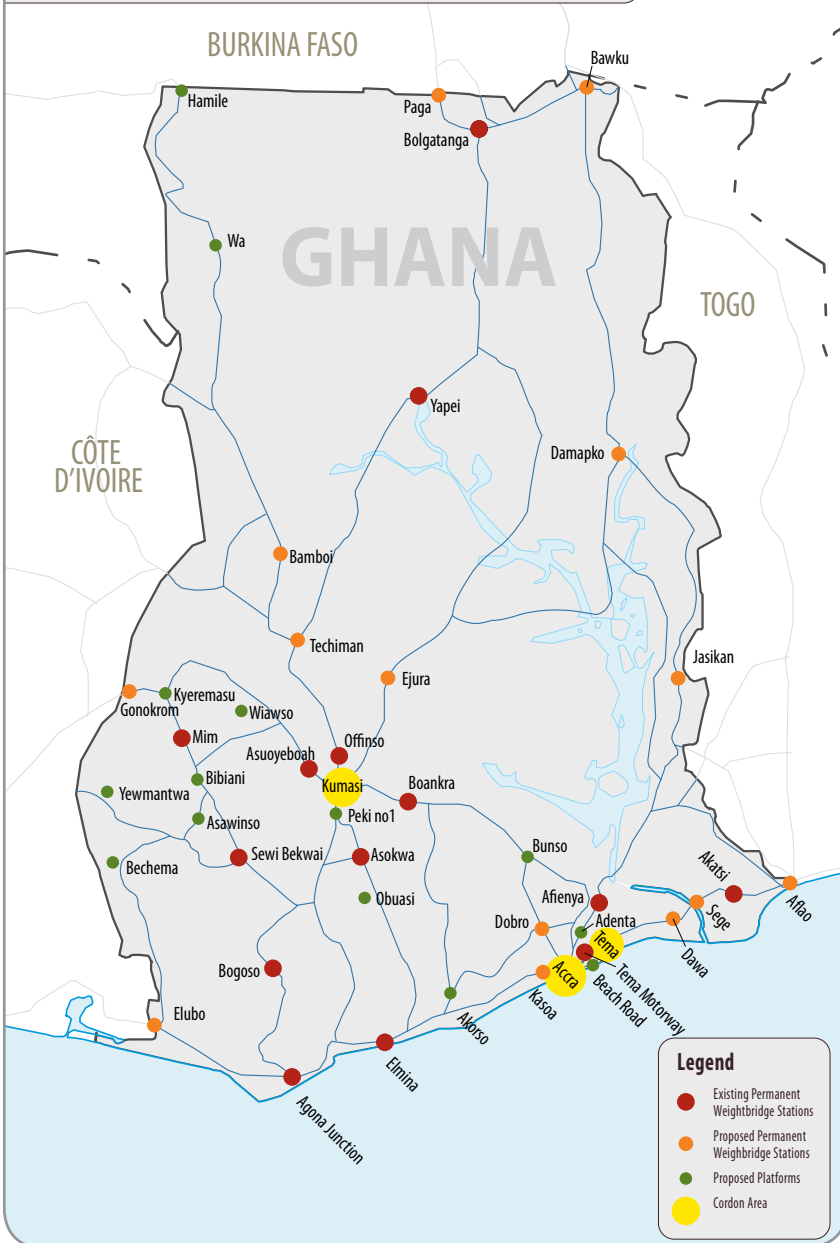



GETTING HELP

Dial +233 for Ghana

Accidents and unforeseen problems happen to even the most experienced and safest drivers. When problems arise, drivers can contact the following organizations for assistance.

For Complaints About Uniformed Officers

Ghana Police Services

Report personally to the Police Intelligence and Professional Standards Bureau (PIPS) office at the National Police Headquarters or call:

- General Office 030 277 6435
- Director-General PIPS 030 278 7236
- 2nd in Command PIPS 030 277 6435
- Director/PIPS 030 276 1263
- E-Mail: pips@ghanapolice.info

Customs Division of the Ghana Revenue Authority

Report to Customs Division of the Ghana Revenue Authority Internal Affairs Unit or report personally to headquarters or customer complaint desks by phone or by mail:

- Phone: 030 267 5724
- Hotline: 028 953 3990

Complaints about Activities at Weighbridges

- GHA Axle Load Manager 024 477 7258
- GHA Chief Executive Officers 030 266 3922

Assistance for Bonds Issued by SIC

Stop at any SIC office along the transit corridor

ISRT Head Office Tema

- Phone: 030 320 3680
- Fax: 030 320 3682
- E-Mail: isrt@sic-gh.com

National Guarantors:

- Phone: 030 320 3680/028 954 1603
- www.isrtguarantors.org – English
- www.cautionstrie.org – French

For Information about Regional Shippers' Councils

Burkina Shippers' Council (CBC)

Phone: 030 320 2392

Entrepôts Malien au Ghana (EMAGHA)

Phone: 030 321 1822

Niger Shippers' Council in Ghana (CNUT)

Phone: 030 321 6880

Ghana Shippers' Authority

Phone: 030 266 6915-7

Complaining about harassment helps police, customs and other services address the problem of corruption among their ranks and make driving safer and more professional for everyone.



Police Regional Headquarters

• Greater Accra Region	Accra Police HQ	030 266 2441	
	2nd in Command	030 266 2290	
	MTTU HQ	030 277 3695	
	MTTU	030 266 4206	
	Info Room	030 277 3906	
	Tema Police HQ	030 320 2259	
• Eastern Region	2nd in Command	030 320 2933	
	MTTU	030 320 2936	
	Info Room	030 320 2937	
	Koforidua Police HQ	034 202 2252	
	2nd in Command	034 202 2453	
	MTTU	034 202 6802	
• Western Region	Info Room	034 202 2569	
	Takoradi Police HQ	031 204 6482	
	2nd in Command	031 204 6559	
	MTTU	031 204 6163	
	Info Room (Sekondi)	031 204 6888	
		031 120 4660	
• Central Region	Cape Coast Police HQ	033 213 2305	
	2nd in Command	033 213 2345	
	MTTU	033 213 2413	
	Info Room	033 213 2465	
		033 213 2463	
	• Volta Region	Ho Police HQ	036 202 8320
2nd in Command		036 202 8322	
MTTU		036 202 6203	
Info Room		036 202 6414	
• Ashanti Region		Kumasi Police HQ	032 202 3484
		2nd in Command	032 202 5787
	MTTU	032 202 5463	
	Info Room	032 202 2323	
		032 202 4944	
	• Northern Region	Tamale Police HQ	037 202 2844
2nd in Command		037 202 2953	
MTTU		037 202 2905	
Info Room		037 202 2297	
• Upper East Region		Bolgatanga Police HQ	038 202 2364
		2nd in Command	038 202 2469
	MTTU	038 202 2304	
	Info Room	038 202 2401	
	• Upper West Region	Wa Police HQ	039 202 2301
		2nd in Command	039 202 2303
MTTU		039 202 2307	
Info Room		039 202 2004	
• Brong Ahafo Region		Sunyani Police HQ	035 202 7356
		2nd in Command	035 202 7332
	MTTU	035 202 7314	
	Info Room	035 202 7159	



WHERE TO GET MORE INFORMATION

The information within this guide was compiled from existing Ghanaian laws. For sources of information for this guide, refer to the following documents and websites:

- The Constitution of the Republic of Ghana, 1992
- The Customs Division of the Ghana Revenue Authority (Management) Act, 1993, PNDC L330
- Road Traffic Act 2004 (Act 683)
- Road Traffic (Amendment) Act 2008 (Act 761)
- Road Traffic Regulation 2012, (LI2180)
- The National Road Safety Commission
<http://www.nrsc.gov.gh/>
- The Ghana Highway Authority
- The Ministry of Roads and Highways
<http://www.mrt.gov.gh/>
- The Ministry of Transport
<http://www.mot.gov.gh>
- Ghana Police Service
http://www.ghanapolice.info/news_2.htm
- Diseases of Animals Act, Act 83. 1961
- The Animals (Control of Importation) Ordinance 1952
- Seed and Pesticides Inspection and Certification Decree NRCD 100 OF 1972
- Plant Protection and Regulatory Services Prevention of the Introduction Pests and Diseases of Plants Act , Act 307 of 1965
- Pesticides Control and Management Act, Act 528 of 1996.
- Plants and Fertilizer Act, 2010
- Motor Vehicle (Third Party Insurance) (ECOWAS Brown Card) Law 1986. PNDC L141

This guide was developed with the cooperation of USAID's West Africa Trade Hub and the following partners:

The National Road Safety Commission (NRSC)

The NRSC of Ghana was established by an Act of Parliament - NRSC Act, 1999 (Act 567). The Act mandates the NRSC to play the lead role in championing, promoting and coordinating road safety activities in Ghana. NRSC's functions include setting standards for road safety equipment and ensuring compliance.

The Ghana Police Service (GPS)

The Ghana Police Service exists to deliver services in crime prevention, detection and apprehension and prosecution of offenders, consistent with the expectation of Ghanaians for maximum protection, personal safety, service and peaceful communities.

The Motor Traffic and Transport Unit of the Ghana Police Service is a branch of the Police which enforce all traffic rules and regulations in Ghana.

The Ghana Highway Authority (GHA)

Ghana Highway Authority (GHA) was established in 1974 as the organisation responsible for the development, maintenance and administration of Ghana's whole road network and related facilities. GHA's principal objective is "to clear the large backlog of maintenance work on the trunk road network and to perform road maintenance on a sustainable long-term basis".

Customs Division of the Ghana Revenue Authority

Customs Division of the Ghana Revenue Authority was established in 1986 as a public service institution under the Ministry of Finance and Economic Planning. The service is the state organisation responsible for the collection of import duties and other taxes. Customs Division of the Ghana Revenue Authority mission is to design and implement effective strategies and programmes to collect, account for and protect customs, excise and other assigned tax revenues at a minimum cost, while facilitating trade, investment and the movement of goods and people across Ghana's borders.

Ghana Ports & Harbours Authority

GPHA is a statutory organization established by PNDC Law 160. GPHA is responsible for the development, management and regulation of Ghana's seaports namely Tema and Takoradi. The services provided by the Ports to customers include but not limited to: Vessel handling, Stevedoring, Storage and Delivery of cargo including containers, Leasing of land, Concessions and licensing of port activities and Regulation of Port Operations. The Authority's mission is to provide efficient and quality Port services to Port Users. Its vision is to be the leading trade and logistics Hub in West Africa.

Ghana Immigration Service (GIS)

The Ghana Immigration Service advises on and ensures the effective implementation of all laws and regulations pertaining to immigration and related issues.

Established under PNDC Law 226 in 1989, Ghana Immigration Service remains the sole institution with the statutory mandate to regulate and monitor the entry, residence, employment and the exit of foreigners in the country. The passage of Immigration Act 2000, Act 573 expanded the functions and roles of the service. Prominent among these are the Indefinite Residence and Right of Abode facilities.

SIC Insurance Company Ltd. (SIC)

SIC was appointed by the government as the National Guarantor for Ghana under the ISRT scheme to provide the needed cover against diversion of transit goods. A gazette was issued in February 2006 to that effect.

Veterinary Services Directorate (VSD)

The Veterinary Services Department of the Ministry of Food and Agriculture was established in 1958 and is responsible for the certification of animal and animal product imports and exports through the entry points by air, sea and land.

Plant Protection and Regulatory Services Directorate (PPRS)

The Plant Protection and Regulatory Services Directorate is responsible for the import and export certification as well as inspection of plants, plant products, seeds, pesticides and fertilizers.

ECOWAS Brown Card Insurance Scheme

Established in 1982 to aid trade, transport and trans-human settlements, the ECOWAS Brown Card Insurance Scheme provides common insurance coverage against Third Party liabilities that may be incurred by motorists driving across the national boundaries of ECOWAS member states.



www.borderlesswa.com

This guide was financed by:



USAID
FROM THE AMERICAN PEOPLE

Endorsed by:



Republic of Ghana
Ministry of Transport



Republic of Ghana
Ministry of Roads and Highways



GHANA SHIPPERS' AUTHORITY



Ghana Highway
Authority



Production coordinated by:

