



170.27MHz R=050 Ω
X=000 Ω SWR=1.00_

1.5 - 3.5MHz
3.1 - 6.8MHz
6.1 - 14.8MHz
13.4 - 31MHz
50 - 96MHz
132 - 170MHz

SET FREQUENCY

VHF AERIAL ANALYSER



OFF
ON

VK5JST 2015

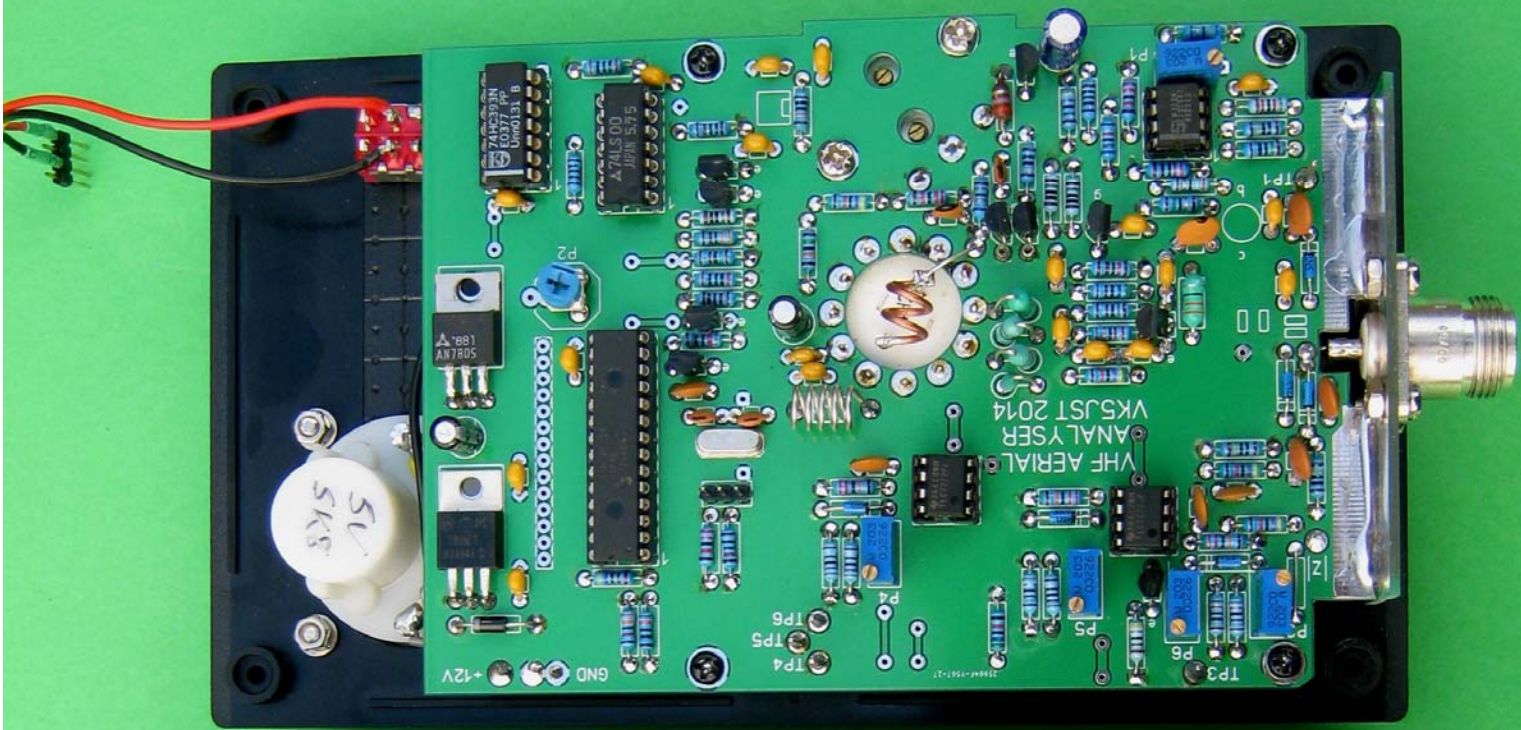

PLEASE NOTE THAT THESE INSTRUCTIONS ARE THE MINIMUM NEEDED TO COMPLETE THE KIT. MUCH MORE, INCLUDING COMPREHENSIVE DIAGNOSTIC DATA, CAN BE FOUND ON THE VK5JST WEBSITE <http://www.users.on.net/~endsodds>

A VHF/HF Aerial Analyser

Jim Tregellas VK5JST

At long last, the 1948 show! No, seriously, I have had a lot of fun developing this analyser which covers all ham bands from 160 to 2 metres, and won't entirely break the bank. It features a 1602 LCD display which like the previous HF analyser, is updated every 100 milliseconds, and shows frequency, SWR, load resistance, and the magnitude of the load reactance.

An optional analog meter is also provided, which shows the magnitude of the load impedance (Z_{total}). This data has many uses, and as an example, allows impedance minimums to be very accurately located. So it will display the antenna load resistance, when the total load impedance of an antenna system has been minimized by careful tuning, and also allows easy development of items like quarter and half waves stubs, and measurements like velocity factor. In combination with the analyzer frequency data, it is a very powerful tool.

Readily available through hole components are mainly used in the construction, and just 5 surface mount components have to be fitted. And like the previous analyser, a Picaxe processor is used, which is loaded with dear old BASIC through a very simple two resistor interface, allowing anyone to play with the code without having to buy special programming tools, or learn an abstruse language like C or assembler. Finally, the analyser uses the best 50 ohm connector around, the type N which is both waterproof and constant impedance. Adapters can be purchased for other VHF quality connectors (BNC, SMA etc) but please don't fit it with a type SO239. This so called UHF connector (40MHz at the time of design) is not constant impedance and simply does not belong on VHF test gear.

The Basic Theory

As in the previous analyser, the SWR, load resistance, and magnitude of the load reactance are derived mathematically by measuring three voltages in a simple test circuit. First, the voltage across the load is measured, as is the voltage across a 50 ohm series resistor (from which load current can be derived). Finally the voltage existing across both the load and 50 ohm series resistor is measured (test network input voltage). The moderately complex mathematics for deriving SWR and load R and Z from these three voltages is up on my website, and in the previous HF analyser article, and will not be repeated here. And unlike the beliefs of some Internet "experts", only a series resistor is required to do this, and NOT a Wheatstone bridge. The balanced structure of this bridge adds nothing to the accuracy of these measurements.

Note that the voltage measured across the load also provides a non linear representation of total load impedance and can be used to directly drive the analog meter too.

How it Works

This test network is the heart of the instrument structure, and a very wide range frequency generator provides 1 volt rms to drive it. This signal level has been selected to totally bury all but the most exceptional interfering signals on the antenna being tested, without flattening the batteries too fast.

Unhappily, analog meters display the absolute value of applied voltage, and so the generator and following test circuit detectors must have a stunningly good frequency response, remaining flat within 1% or so over the total frequency range, so that the analog meter display of magnitude of load

impedance is correct. The oscillator and following power amplifier consequently must have a first class AGC system. (In a digital only instrument all calculations use the RATIOS of the various test circuit voltages and so this requirement is relaxed greatly allowing a simpler cheaper but less useful instrument).

The oscillator uses a differential amplifier containing a matched pair of VHF fets (TR1 and TR2). A parallel tuned circuit in the drain of TR1 maximises the gain of this transistor pair at a single frequency and the positive feedback path to create oscillation occurs via the source follower action of TR2 which couples energy back to TR1 via the coupled sources of these two transistors. Another source follower TR3, buffers the oscillator output from the tuned circuit and drives the power amplifier TR5. This amplifier has a special and unusual bias circuit TR4, which samples the current drawn by TR5 via R2 and sets the collector current of TR5 to the 57mA required to drive the 50 ohm test circuit with 1 volt rms, providing some design margin and very little waste. Note that this amplifier has a permanent load composed of 2@100 ohm resistors which are there to limit the amplifier voltage gain when the test circuit has no load. The generator must thus provide 1 volt rms (with margin) into around 40 ohms (+14dbm) when the item being tested is a short circuit.

AGC to control this structure is developed from a dc voltage produced from envelope detector D1, C23, and R47. This dc voltage represents the peak value of the rf voltage being applied to the test circuit and is buffered by unity gain amplifier IC1A. The output voltage of this stage is compared with a dc control voltage appearing on pin 5 of the inverting amplifier IC1B (gain of 10). In turn the output voltage of this stage is applied to the base of TR6, which determines the total current flowing through TR1 and TR2, hence determining the total gain of the differential pair and the level of oscillation. The level of oscillation is adjusted with trimpot P1.

All of the detector outputs from the test circuit (derived from D1,D2, D3) provide dc outputs which are in turn buffered and have their considerable non linearities largely compensated for in some following op. amp. circuitry (IC5 and IC6). These three compensated dc output voltages then drive the analog meter, and the A/D converter inputs of the microprocessor, from which SWR and load characteristics are calculated.

Finally, the generator frequency is calculated every 100 milliseconds or so by the microprocessor. For frequencies under 30MHz, a voltage sample from the input to the test circuit is directly routed to IC4 (74HC393) via an amplifying and steering circuit IC3 (74LS00) where it is divided by 128 before being fed to the microprocessor for counting and gating. For frequencies above 30MHz, some extra high speed prescaling is required, and this is done using an ECL decade divider chip IC2 (MC12080). This chip is followed by a non saturating ECL to TTL translator stage (TR9 and TR10) which in turn provides the second input to the IC3 steering stage. The prescaler structure in use is determined by a logic level derived from the tank circuit of the oscillator. For the two upper frequency ranges, the 8 volt supply rail is connected to the base of TR7 via resistors. TR7 is thus off, as is TR8, and so pins 2, 4, and 5 of IC3 are pulled high via R20, connecting the output of IC2 to the input of IC4 via IC3 and adding the extra prescaling. Note that the logic level at TR8 collector is also supplied to the microprocessor to shift the decimal point in the displayed frequency.

Building The Analyser- Mechanical Work

COMPLETE ALL WORK ON THE CASE FIRST. Doing assembly in this order allows you to use the bare printed circuit board to check marking out.

Marking out is probably most easily done by printing up the case drawings exact size, and attaching them to the correct surfaces of the UB2 box with thin double sided tape. A very sharp scribe can then be used to prick through the hole centres or corners into the plastic. Check the exact size of the LCD you have decided to use. The front panel drawing shows the 24 x 71mm hole used by industry standard LCDs but yours may be different. For all circular holes, drill a small pilot hole first (around 1.5mm dia.) using the pricking to centre the drill, and then slowly open out to final size using either a larger drill, or for larger holes, a step drill, fly cutter or hole saw. Using ordinary metal working drills in this sort of plastic is dangerous. Clamp all work and use slow gentle feed rates while drilling. Use a grinder to reduce the rake angle on the drill leading edges to zero, which will stop the drill grabbing and trying to rip the box out of the holding clamps. The holes for the LCD and N connector can be roughly formed with a jig saw first or by drilling a series of nearly touching holes (around 5-6mm dia.) just inside the borders of the rectangular hole. It is then carefully filed to final shape. The cutout for the tuning knob in the case lid is probably best formed with a half round file. Find something around 80mm diameter (a tin can or cup) and use this to keep an eye on the circular shape as you file this arc to a depth of 4mm. The arc can be smoothed off with fine sandpaper to finish it. The case bottom has two items to be formed, the cutout for the tuning knob in the top surface of the right hand side, and the hole for the type N or BNC connector in the top end of the case. Please see the relevant drawings.

Building the Analyser- Initial Preparations

The Rotary Switch

In past designs, the plastic rotary switch used for frequency range selection has caused much confusion because builders will not take the time to learn how to set them up properly. The 6 position 2 pole switch used in this instrument can be rotated through twelve possible positions, and so rotation can either start clockwise from position 1 or anti clockwise from position 12. Just how many positions are available is determined by an adjustable travel limiting stop to be found under the main mounting nut. So you can make any 2 pole switch with from 2 to 6 positions, starting either at pin 1 or pin 12. To set up the switch in this instrument, first remove the adjustable stop entirely and then, looking at the front of the switch, rotate it fully clockwise to position 12. Then put the travel limiting stop into position 6. (between the L and P in the ALPHA brand) Done! Note how it is placed into the printed circuit board with the central common terminals being placed at the 4 and 10 o'clock positions, looking at the back of the switch on the component overlay drawing, with the N connector at the top of the diagram. BEFORE you solder it into position, check with your ohm meter that the common terminal at 4 o'clock bridges to the 6 outer terminals between 12 and 5 o'clock. The common terminal at 10 o'clock will thus sweep through the switch positions from 6 to 11 o'clock.

Make a mistake here and you may very well wreck the pcb when you try desolder the switch from it. And finally make your soldering quick. These switches go open circuit when exposed to excess soldering temperature/times.

The Optional Analog Meter

The meter used is available very cheaply on the "net" and typically can be bought as a type 91C4 or 91L4 with a built in series resistor for 5 volt FSD. This meter just requires rescaling and here is how. Buy a single A4 Avery label sheet (80- 100gsm) from your local stationer, and print the meter scale on to it from the PDF to be found on my website. With a very sharp pointed hobby knife cut out the meter scale. In a CLEAN environment, remove the meter face and scale. Remove the label backing,

exposing the sticky back. The label goes on the back of the existing scale. Carefully align the top of the label with the top of the meter scale and then stick the two together, removing all air bubbles. Cut around the bottom of the assembly with the point of a very sharp hobby knife and then reassemble the meter.

If you cannot get a 91C4 meter with a 5 volt scale, note that any 91C4 meter with a voltage scale can be used. All you have to do is remove the internal series resistor (see the photo on my website) to convert the volt meter back to a current meter. The correct resistor to give full scale deflection with 5 volts dc applied is then added to the pcb in the position marked "TEXT". Depending on exactly which meter you bought, this resistor could be anywhere from 2-100K. Start at the high value first. For 5V FSD meters, the pcb "TEXT" positioned is bridged with a shorting link.

Matching TR1 and TR2

It is vitally important that these fets are carefully matched. Failure to do so will result in an oscillator/power amplifier which probably works correctly on the upper two frequency ranges but "squeggs" on all other ranges i.e puts out short bursts of rf at a low audio frequency. This occurs because the AGC is unable to back off the oscillator gain enough, owing to the mismatched devices. DO NOT mix brands when matching.

I bought a batch of 20 J310 fets from the "net" and matched them up using the simple circuit shown in a standard prototyping whiteboard. The spread in current was from 50-92 microamp over the batch. I matched up 3 pairs at 53, 73, and 94 microamp within 1.0 microamp and experienced no problems with squegging in the analyser. I used the 73 microamp pair in the final prototype. Note the bypass capacitor in the test jig. Without it the fet may oscillate at VHF, upsetting the matching. Make sure it is connected directly between gate and drain with the shortest leads possible. Also note that the pin out of a J310 does not match that shown in the simple diagram below. It is actually gate, source, drain.

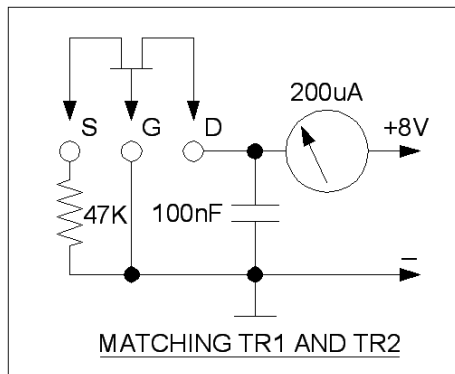

The Coils

The coils for the two upper frequency ranges are wound on the shank of a 5mm drill. The highest range uses a 44mm length of 1.2mm dia copper wire formed into two turns and quickly soldered between the two common terminals of the rotary switch. Do this BEFORE mounting the switch on the main pcb. The other coil comprises 5 turns of 0.8- 1.0 mm dia. copper wire. Carefully scrape and tin the ends of both coils before assembly.

Final Assembly

First, solder the connector printed circuit board to the mainboard. Use the two alignment ears provided at the edges of the connector board copper pattern to exactly centralise it relative to the main board, and tack it into position using minimum solder. Check that the two boards are at right angles and then complete all soldering forming 4 strong bonds between the two boards. Use at least a 45 watt iron for this.

Next, add all small components to the pcb using the component overlay and circuit drawings as guides. ASSUME NOTHING!!. Use your DVM to check the value of every resistor before installation. Depending on who made them, the PN2222 and 2N3906 come with two different styles and for this reason, the locating flats on these transistors are not shown on the component overlay. Check the pinout of your transistors using the current gain feature on your DVM. An indicated current gain of more than say 40 shows you have the correct pinout. The BFR96 is mounted on the track side of the pcb with its label facing the pcb surface. Trim the 3 leads to an appropriate length. The collector is the long lead. USE IC SOCKETS. Note that the MC12080 and 4@100 ohm surface mount resistors are also mounted on the track side of the pcb. The lead lengths of all capacitors should be kept as near to zero as possible by installing them with their bodies hard up against the printed circuit board. Do not expect the analyser to work properly if you have used anything other than the multiplate monolithic bypass and coupling capacitors specified and/or have the capacitors sitting up in the air on the end of 4mm long leads.

Mount all of the trim pots with their adjustment screws in the position shown on the component overlay. This will allow you to reduce each test voltage by rotating the screws in an anti clockwise direction. When adjusting a 25 turn trim pot, it is very easy to become totally confused if you do not take this simple precaution.

Do not plug in any ICs yet. Double check the orientation of all diodes and electrolytic capacitors. Leave the mounting of the tuning capacitor and rotary switch until last. Before you mount the tuning capacitor on its little daughter board, adjust the two trimmer capacitors at the back of the capacitor so that they are totally out of mesh. Attach the tuning capacitor assembly to the TRACK side of the main pcb using 12mm long spacers. Last, mount the rotary switch assembly (switch and 2 turn coil) on the TRACK side of the pcb making sure that the two common terminals are positioned as shown on the component overlay at 4 and 10 o'clock (see also the earlier paragraph "The Rotary Switch"). Attach the N connector to its pcb with 3mm screws and nuts, and connect the central terminal to the main board using the shortest length of wire possible. Finally solder on all main board flying leads, using 180mm lengths of multicoloured hook up wire.

Assemble the front panel. Add the four 30mm long screws which support the main board to the front panel using 4@ 3mm nuts. Use another 8 nuts to space and hold the main board away from the front panel by 21mm. Install the front panel label and mount the meter and on/off switch. Mount the LCD to the front panel using two thicknesses of 2mm thick double sided foam tape at the display top and bottom (from your local "Cheap" shop). Complete all wiring and then finally permanently mount the main board. Note that it is possible to interconnect the LCD and main board using 9 wires instead of 14, provided that you connect all of the earthed points together on the display. As both +5v and ground are available at the display terminals, it is also a simple matter to add backlighting if your display has it. To do this, ground pin 16 (if your display has a standard pin out). Assuming that the

LCD has around 100 ohms of LED current limiting resistance built on to its pcb, battery life can be maximized by placing another 120 ohms between +5v (pin 2) and pin 15. Finally attach the 10 cell battery holder to the bottom of the box, again using 2mm thick double sided foam tape.

Testing and Setup

Select the lowest frequency range and insert IC1 only. Monitor the total current drawn with a DVM (2 amp range). Switch on. The total current should be around 120mA if all is well and the upper line of the LCD should show a row of black squares after the contrast trimpot P2 has been set correctly. Check TP1 with a DVM and adjust P1 until 1.17 volts appears there. Check the output with an oscilloscope for 2.8 volts peak to peak (1 volt rms) of good clean sine wave that should now be present. Switch through all frequency ranges and then go back to the lowest frequency range. The voltage at TP1 should remain within 1% (1.16- 1.18 volts) indicating a very flat rf output level over the total frequency range.

Switch off and add all other ICs except the Picaxe processor. Switch on.

Set TP4 to 4.40V using P4. Then using P3, set TP3 to 5.00V (no meters) or full scale on the "Z" meter. The voltage at TP3 to produce FSD on the meter should be within the limits 4.8-5.2 volts. If it is not, adjust the value of meter series resistance until it is. Note that many anticlockwise turns of the trimpots may be necessary to reduce this test voltage to 5V.

Add a really good 50 ohm dummy load to the output (type N 50 ohms 0.5W and good to 1GHz). Adjust both TP5 and TP6 to 2.06 volts using P5 and P6. Switch off and add the preprogrammed Picaxe 28X2. Switch on. At startup, after the contrast trimpot P2 is further adjusted to give the best display, the LCD should indicate the battery voltage within 5%. A few seconds later, it will indicate the frequency, load resistance (50 ohms), magnitude of load reactance (zero ohms) and SWR (1.00). Now switch through all the frequency ranges and check that the SWR remains under 1.05 and the indicated resistance stays within the range 48-52 ohms. The reactance X should remain at zero. If all is well, go back to the lowest frequency range and load the output with a 0.25W 150 ohm metal film resistor. A resistance of 150 ohms +/- 10% should be indicated with X=0. Also check using a 10 ohm resistor. Please note that the exact test point voltages required to produce the above results depend to a small degree on how well the resistance of the dummy load matches that of the internal 50 ohm current sensing resistor (R36//R37) and the relative matching of the diodes in the three envelope detectors. Bluntly, you may have to play around very slightly with P5 and P6 to get the best compromise over the total frequency range. Note that the setup procedure forces the microprocessor to calculate and display a load resistance of 50 ohms, cancelling all tolerances in both the internal 50 ohms and dummy load, and so the analog meter and LCD figures may not exactly agree. Tweaking P3 slightly can resolve this difference.

Both the indicated frequency and battery voltage may be slightly in error due to component tolerances. See my website for the software tweaks to fix this.

Final Comments

Having just waded through what is quite a complex set up process, builders will probably be wondering why at vhf, when there is nothing attached to the N connector, the analyser does not show infinite SWR and an open circuit. The answer is quite simple. Ordinary 50 ohm transmission line has

a capacitance of around 100pf/metre and an inductance of around 0.25uH/metre, and the analyser has a permanently connected length of 50 ohm line (30-35mm long) connected to its measurement circuit in the form of the N connector. So with nothing connected to the analyser the measurement circuit sees around 3-4 pf of connector and stray capacitance (250 ohms @ 160MHz), while if you “short” the output, the analyser sees around 8-9nH of connector inductance (9 ohms @160MHz). There are some small losses too which will also be indicated.

None of this really matters in normal measurements, because you used a nice 50 ohm N connector, instead of a horrible, anything but 50 ohm, SO239. The 30-35mm of connector length simply becomes part of the connecting transmission line and disappears. The connector length only becomes important in odd applications such as the making of phasing lines to connect multi antenna arrays together at VHF. In this case, you will have to make the phasing line 30-35mm longer than the analyser indicates.

Anyway, many congratulations. You now have a piece of test gear which will conclusively demonstrate why the transistors in your transceiver final stage recently went pffffit. ☺

And Really Finally

My profound thanks to my two very good friends Barry Williams VK5BW and Wolf Langmair VK5WF, who waded through my initial drafts of material for this project, and somehow, despite the many errors I made, managed to construct two working prototypes, and tactfully tell me about my blunders at the same time. If you do make one of these analysers successfully, it is in no small way due to the efforts of these two.

References :

VK5JST web site <http://www.users.on.net/~endsodds/> for printed circuit boards, software, photos and many more details.

Adelaide Hills Amateur Radio Society website <http://www.ahars.com.au/> for a complete kit of parts.

Special Notes For AHARS Kit

1. All 3@ J310s supplied in the kit are closely matched electrically, and any 2 can be used for the matched pair TR1 and TR2.

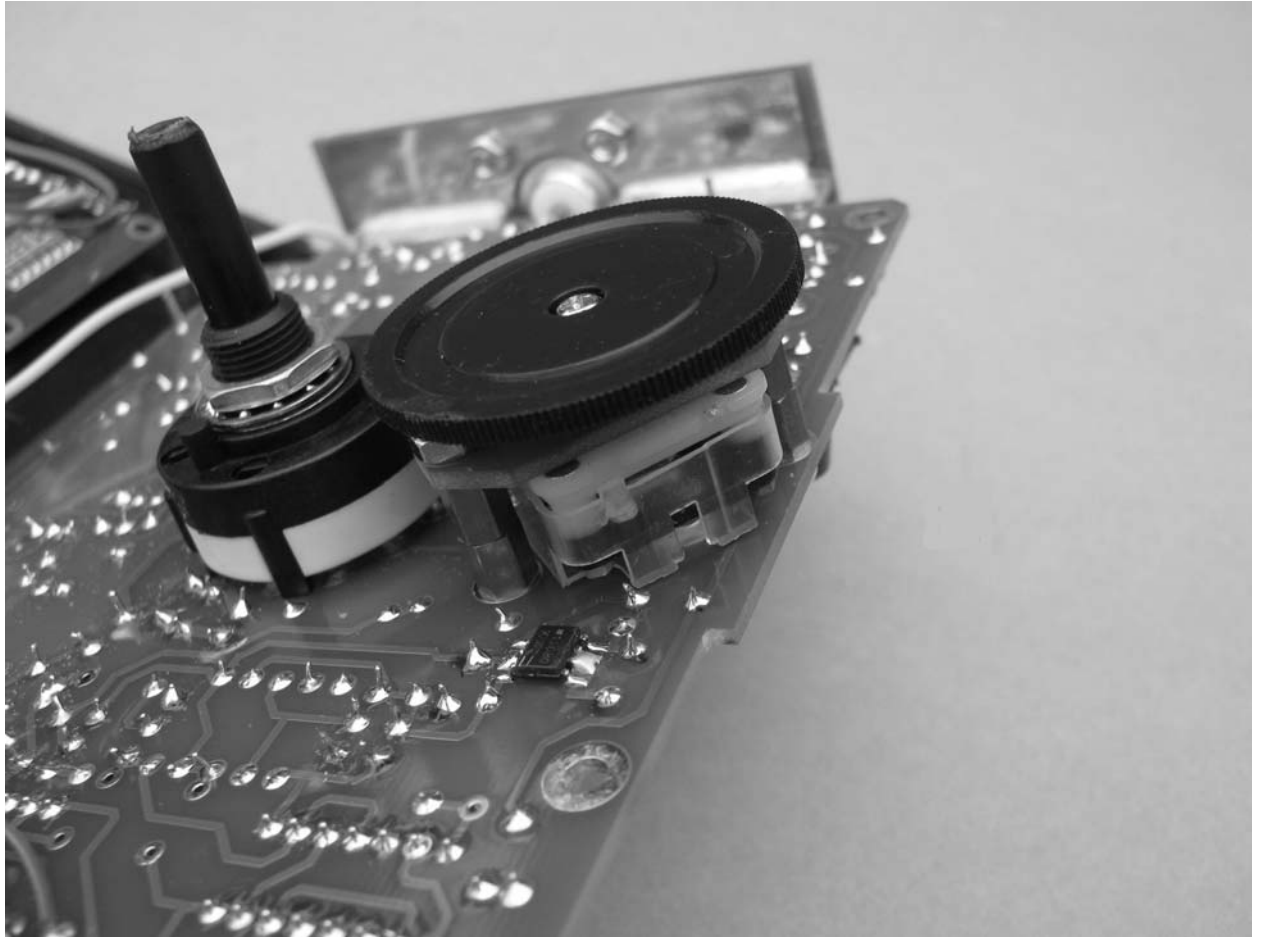

TR1 AND TR2 ARE A MATCHED PAIR-SEE TEXT

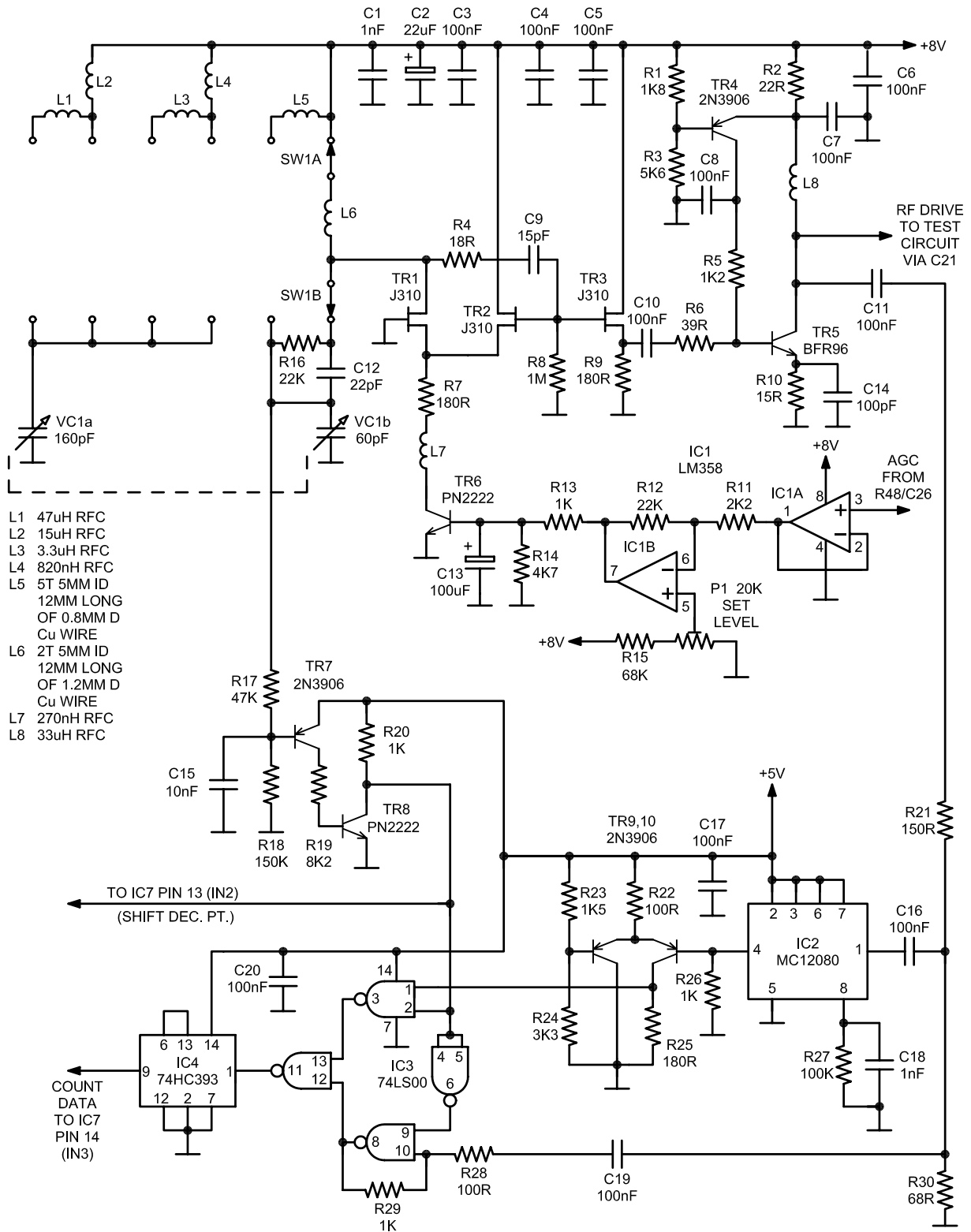

- L1 47uH RFC
- L2 15uH RFC
- L3 3.3uH RFC
- L4 820nH RFC
- L5 5T 5MM ID
12MM LONG
OF 0.8MM D
Cu WIRE
- L6 2T 5MM ID
12MM LONG
OF 1.2MM D
Cu WIRE
- L7 270nH RFC
- L8 33uH RFC

VHF AERIAL ANALYSER PART 1

RF GENERATOR AND FREQUENCY PRESCALING

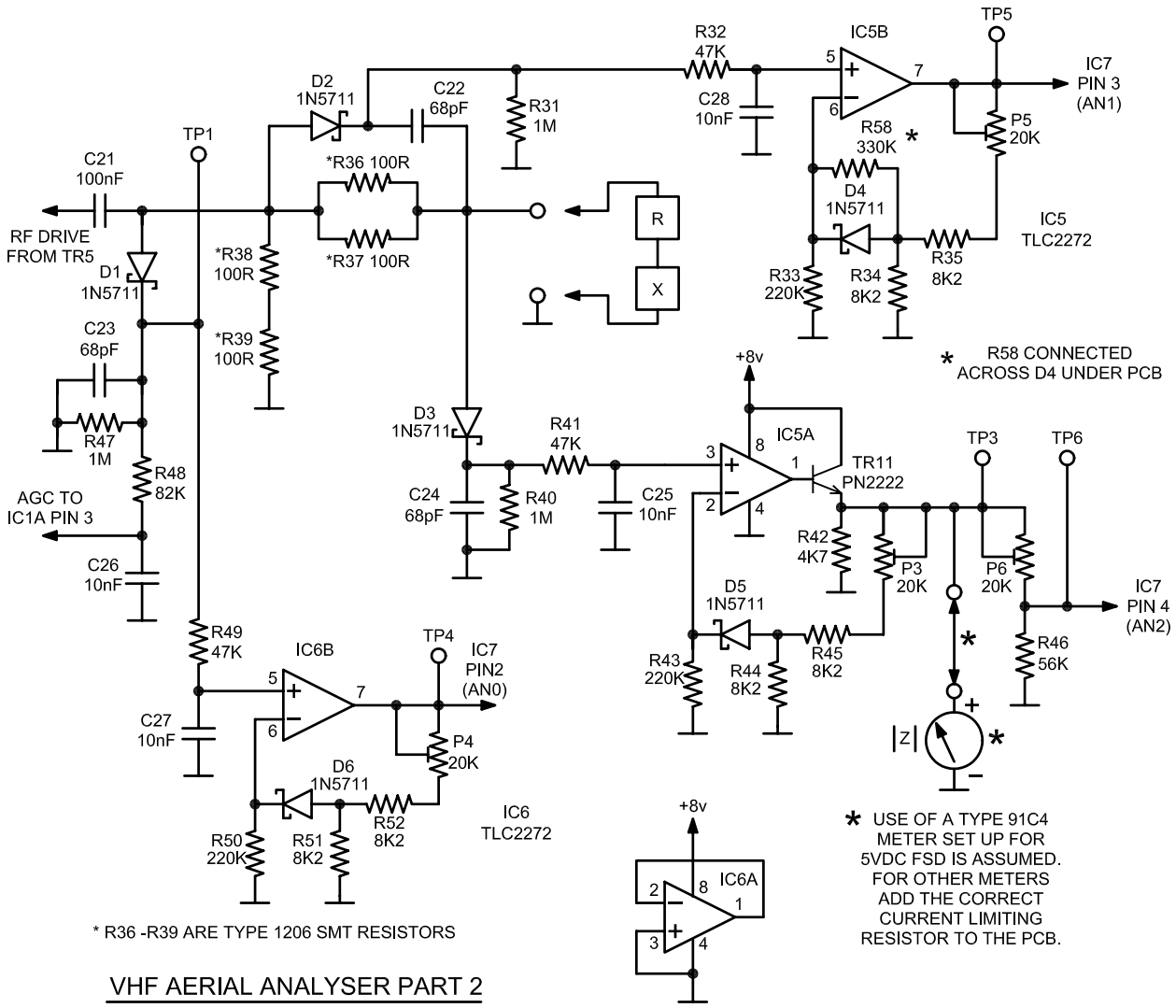

* R36 -R39 ARE TYPE 1206 SMT RESISTORS

* R58 CONNECTED ACROSS D4 UNDER PCB

* USE OF A TYPE 91C4 METER SET UP FOR 5VDC FSD IS ASSUMED. FOR OTHER METERS ADD THE CORRECT CURRENT LIMITING RESISTOR TO THE PCB.

VHF AERIAL ANALYSER PART 2
TEST CIRCUIT, DETECTORS, AND METERING

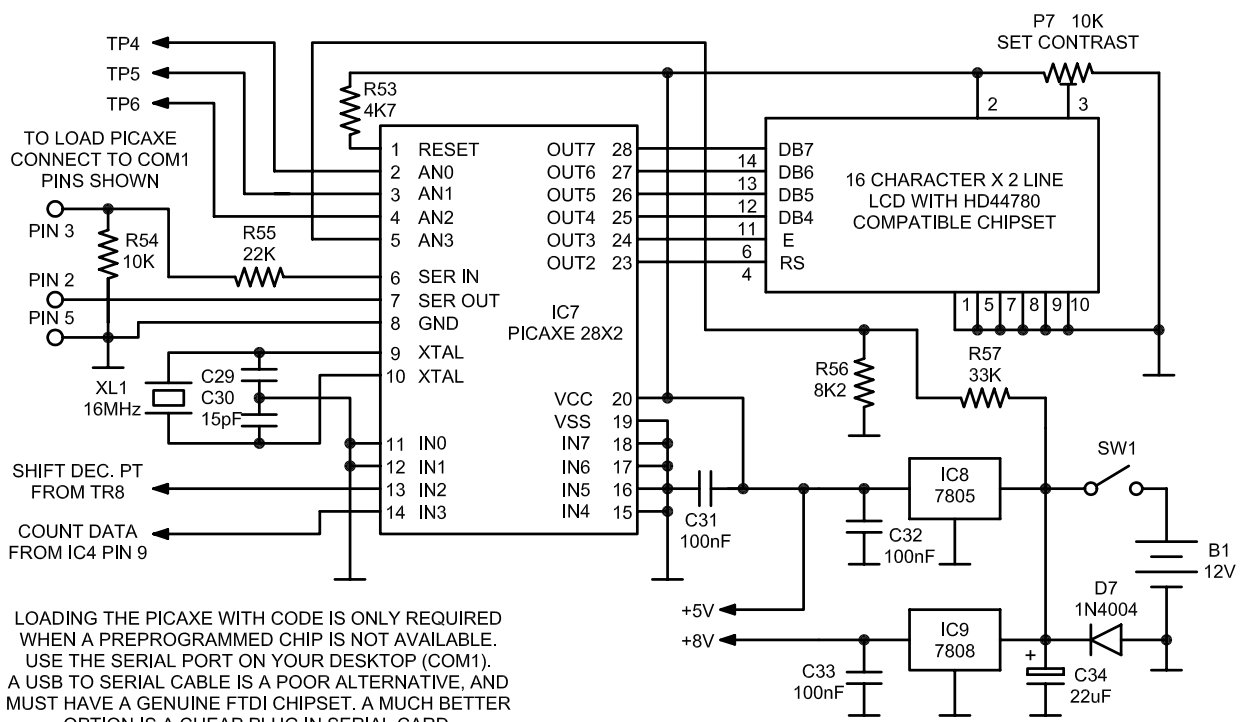

VHF AERIAL ANALYSER PART 3
MICROPROCESSOR CONTROL, DISPLAY, AND POWER SUPPLY

THE FOLLOWING COMPONENTS ARE MOUNTED ON THE REAR (TRACK SIDE) OF THE PCB...

4@ 100R SMT RESISTORS
MC12080 PRESCALER CHIP
BFR96

** USE YOUR DVM TO CHECK THE PINOUTS OF BOTH PN2222 AND 2N3906 BEFORE INSERTION

COMPONENT LEGEND

- 1N4004
- 1N5711
- PN2222
- 2N3906
- J310
- BFR96
- 15pF NPO
- 22pF NPO
- 68pF CER.
- 100pF CER.
- 1nF MONO
- 10nF MONO
- 100nF MONO
- TO SUIT METER. SHORT CIRCUIT FOR 5V FSD METERS.

R58 (330K) IS SOLDERED ACROSS THIS DIODE UNDER THE PCB

TO LOAD PICAXE, CONNECT TO COM1 PINS SHOWN

CONNECT TO PINS 1 - 14 ON LCD USING FLYING LEADS (SEE TEXT)

TO 10 CELL AA BATTERY HOLDER

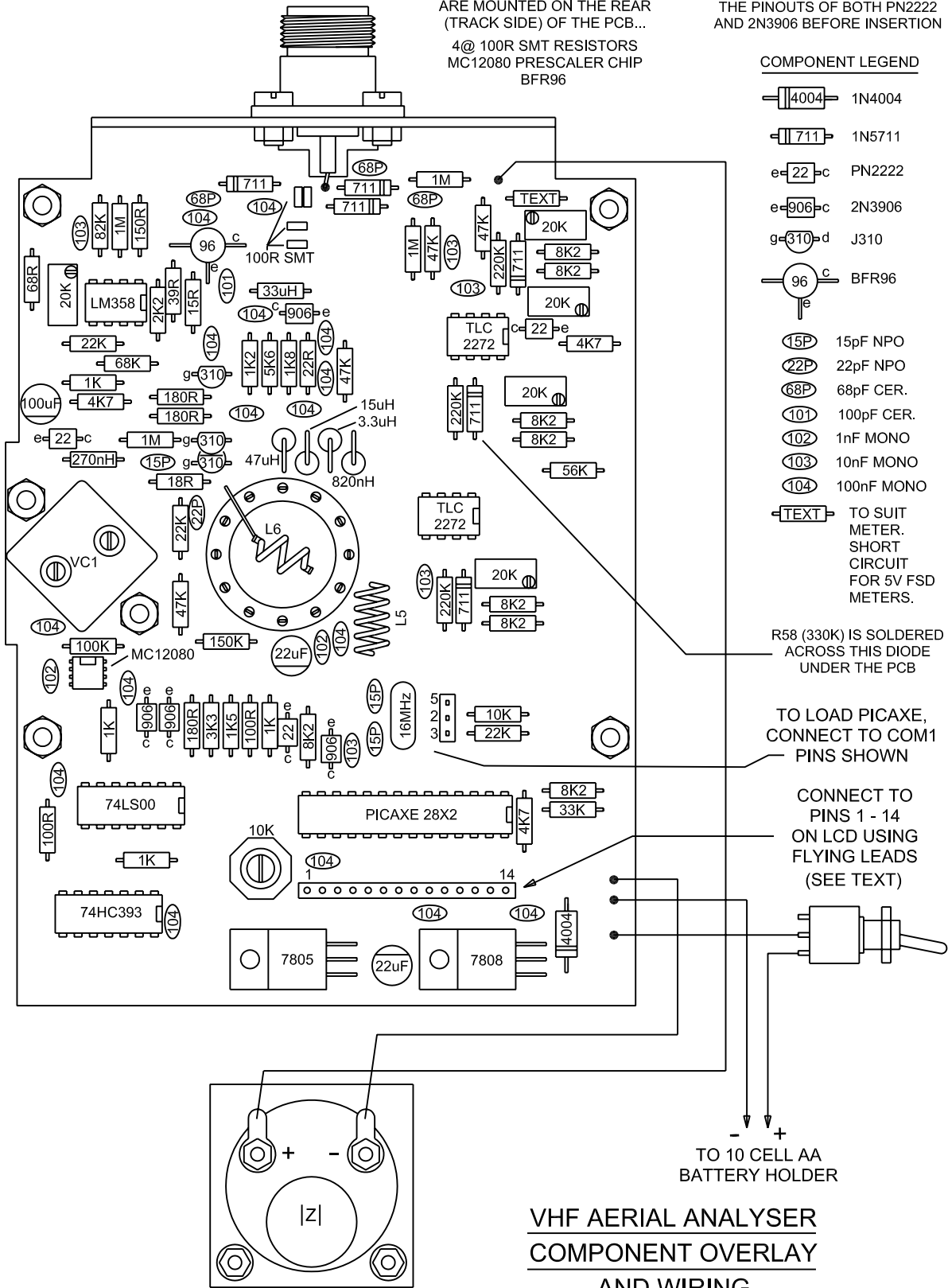

VHF AERIAL ANALYSER
COMPONENT OVERLAY
AND WIRING

VHF AERIAL ANALYSER PARTS LIST

Resistors (all 0.25W 5% unless otherwise specified)

1@ 15R
1@ 18R
1@ 22R
1@ 39R
1@ 68R
4@ 100R SM type 1206
2@ 100R
1@ 150R
3@ 180R
4@ 1K
1@ 1K2
1@ 1K5
1@ 1K8
1@ 2K2
1@ 3K3
3@ 4K7
1@ 5K6
8@ 8K2
1@ 10K
3@ 22K
1@ 33K
4@ 47K
1@ 56K
1@ 68K
1@ 82K
1@ 100K
1@ 150K
3@ 220K
1@ 330K
4@ 1M

Trimpots

5@ 20K Jaycar type RT4652 or equiv.
1@ 10K Jaycar type RT4360 or equiv.

Capacitors

3@ 15pF NPO 50V disc ceramic
1@ 22pF NPO 50V disc ceramic
3@ 68pF 50V disc ceramic
1@ 100pF 50V multiplate monolithic 0.2 inch lead spacing
2@ 1nF 50V multiplate monolithic 0.2 inch lead spacing
5@ 10nF 50V multiplate monolithic 0.2 inch lead spacing
16@ 100nF 50V multiplate monolithic 0.2 inch lead spacing
2@ 22uF 25V pcb mtg aluminium electrolytic
1@ 100uF 25V pcb mtg aluminium electrolytic
1@ tuning capacitor with knob (Jaycar part no. RV5728)

Inductors

1@ 270nH RFC

1@ 820nH RFC
1@ 3.3uH RFC
1@ 15uH RFC
1@ 33uH RFC
1@ 47uH RFC
1@ 5 turn coil - 0.9mm TCW wound on 5mm dia. former(see notes)
1@ 2 turn coil - 1.2mm TCW wound on 5mm dia. former(see notes)

Semiconductors and Sockets

6@ 1N5711 Schottky diodes
1@ 1N4004 or equiv.
3@ J310 (2 used in matched pair-TR1/TR2)
1@ BFR96
3@ PN2222
4@ 2N3906
1@ LM358
2@ TLC2272CP, TLC27L2CP, or equivalent
1@ 74LS00
1@ 74HC393
1@ MC12080
1@ PICAXE 28X2
1@ 7805
1@ 7808
4@ 14 pin DIL sockets (use 2 for 28 pin Picaxe)
3@ 8 pin DIL sockets

Miscellaneous

1@ type N panel mounting rf socket (rfsupplier.com part no. N01-FJHL4-41BS00 or equiv.)
8@ panhead or cheesehead plated M3 screws 6mm long
4@ countersunk plated M3 screws 30mm long
16@ M3 plated nuts
2@ 12mm long tapped nylon spacers (Jaycar part no. HP0924 or equiv.)
1@ SPDT switch C&K 7101 or equiv.
1@ type 91C4 panel meter for 5VDC FSD
1@ meter scale for 91C4 meter
2@ 3mm bore solder tags
1@ 16 character X 2 line LCD with HD44780 or equivalent chipset
1@ 6 position 2 pole rotary switch (Jaycar part no. SR1212 or equiv.)
6@ 1mm dia. PC pins
1@ knob for 0.25 inch dia. shaft
1@ UB2 box
1@ front panel label
1@ 10 cell AA battery holder (Jaycar part no. PH9210 or equiv.)
3@ printed circuit boards
1@ 3 pin 0.1 inch spaced header strip
1@ 16MHz HC49U crystal
1@ set of assembly instructions
Hookup wire, solder

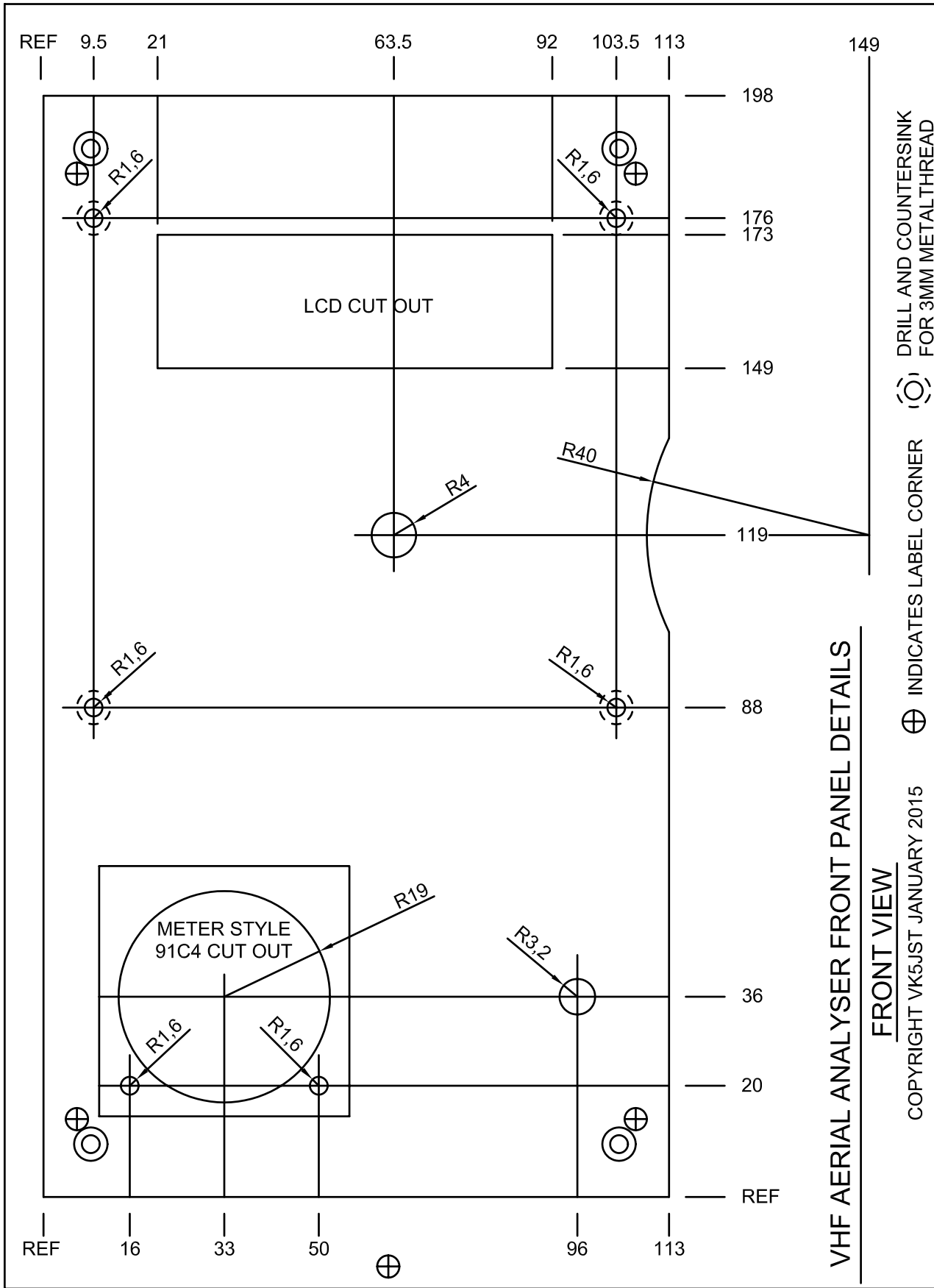

VHF AERIAL ANALYSER FRONT PANEL DETAILS

FRONT VIEW

COPYRIGHT VK5JST JANUARY 2015

⊕ INDICATES LABEL CORNER
 ⊕ ⊕ DRILL AND COUNTERSINK FOR 3MM METAL THREAD

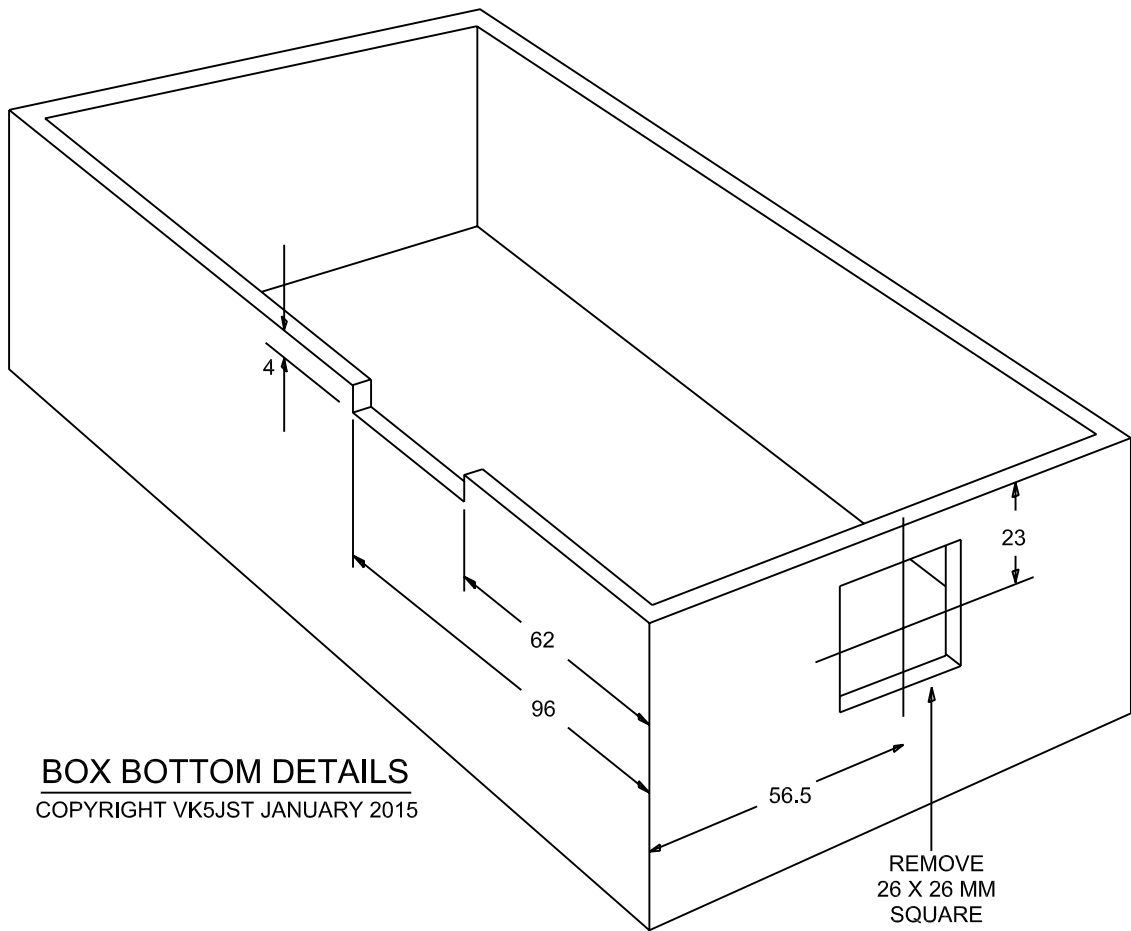

BOX BOTTOM DETAILS
COPYRIGHT VK5JST JANUARY 2015