

C.I.P.**500 S&W Mag**

TAB. IV

Datum 04-05-18

Revision 08-04-15

Ursprungsland: US

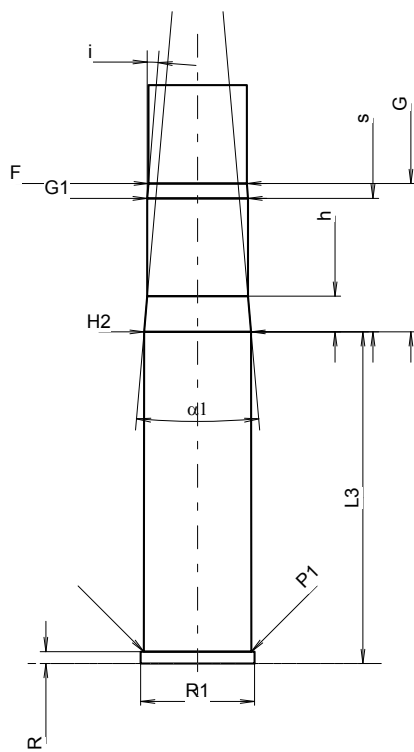
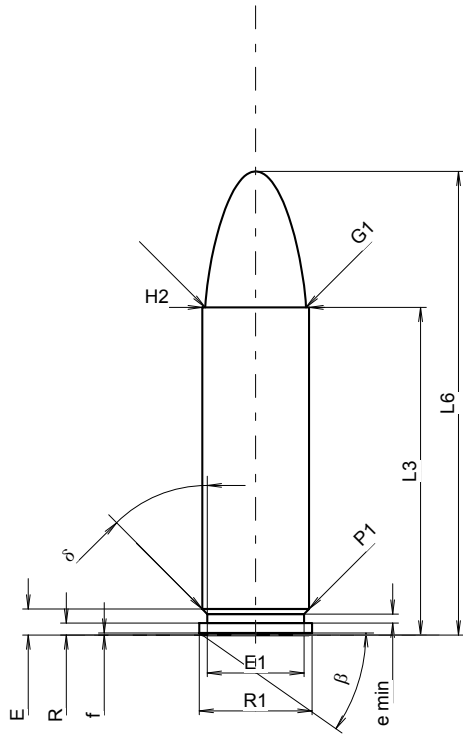

Maßstab 1.05:1

Maße in << mm >>
Maße und Toleranzen für Messläufe
siehe Anhang CR 1.

PATRONE MAXI**Längen**

L1	=	
L2	=	
L3 ¹⁾	=	41.28
L4	=	
L5	=	
L6	=	58.42

Hülsenboden

R ¹⁾	=	1.50	-0.25
R1	=	14.22	
R3	=		
E	=	3.28	
E1	=	12.19	
e min	=	1.14	
delta	=	45°	
f	=	0.26	
beta	=	35°	

Pulverkammer

P1	=	13.46
P2	=	

Schulterkonus

alpha	=	
S	=	
r1 min	=	
r2	=	

Hülsenhals

H1	=	
H2 ¹⁾	=	13.46

Geschoss

G1 ¹⁾	=	12.70
G2	=	
F	=	
L3+G ¹⁾	=	59.98

Drücke (Energien)**Mech. elektr. Wandler**

Pmax	=	3950 bar
PK	=	4543 bar
PE	=	5135 bar
M	=	23.00

Verschiedene Daten

Fe ¹⁾⁴⁾	=	0.25
delta L	=	

PATRONENLAGER MINI**Längen**

L1	=	
L2	=	
L3 ¹⁾	=	41.79

Stoßboden

R ¹⁾	=	1.50
R1	=	14.35
R2	=	
R3	=	
r	=	

Pulverkammer

E	=	
P1 ¹⁾	=	13.54
P2	=	

Schulterkonus

alpha	=	
S	=	
r1 max	=	
r2	=	

Hülsenhals

H1	=	
H2 ¹⁾	=	13.49

Geschossübergang

G1 ¹⁾ *	=	12.70
G ¹⁾	=	18.70
alpha1 *	=	10°
h	=	4.51
s *	=	16.83
i ¹⁾ *	=	4°35'
w	=	

Lauf

F ¹⁾ *	=	12.40
Z ¹⁾	=	12.66

Züge

b	=	3.30
N	=	6
u	=	476.30
Q	=	123.37 mm ²

Bemerkungen: 1) Kontrolle aus Sicherheitsgründen
4) Verschlussabstand an Rand
* Grundmaße