



Doctoral Thesis

Variant management of modular product families in the market phase

Author(s):

Avak, Björn

Publication Date:

2006

Permanent Link:

<https://doi.org/10.3929/ethz-a-005320674> →

Rights / License:

[In Copyright - Non-Commercial Use Permitted](#) →

This page was generated automatically upon download from the [ETH Zurich Research Collection](#). For more information please consult the [Terms of use](#).

DISS. ETH NO. 16885

**VARIANT MANAGEMENT OF MODULAR PRODUCT FAMILIES
IN THE MARKET PHASE**

A dissertation submitted to
ETH ZURICH

for the degree of
Doctor of Sciences

presented by
BJÖRN AVAK

Master of Science, Georgia Institute of Technology
born 17.04.1980
citizen of Germany

accepted on the recommendation of
Prof. Dr. Konrad Wegener, examiner
Prof. Dr. Johan Malmqvist, co-examiner

2007

Acknowledgments

This work is the result of my time at the Center for Product Design at ETH Zurich, where I was responsible for the applied research project KTI No. 7463.2 ESPP-ES. In the scope of this project, methods to conduct variant management were developed and implemented in several industrial companies. My thanks go to the people who have supported me along the way.

First of all, I would like to thank Prof. Dr. Konrad Wegener for taking over supervision of my work after the death of Prof. Dr. Markus Meier, who initiated the research project. I am very grateful to Prof. Wegener for taking the time for regular and extensive meetings despite his tight schedule. His ability to focus on scientific details, while keeping the broad industrial objectives in mind has been a great source of inspiration. I am also grateful for the always productive and amicable working environment.

Prof. Dr. Johan Malmqvist from Chalmers University of Technology in Gothenburg assumed co-supervision and facilitated my research stay at Chalmers. I would like to thank him for providing some very valuable inputs and for the cordial cooperation.

Prof. Dr. Roland Siegwart took over responsibility of the Center for Product Design in summer 2006. I would like to thank him for a positive and always supportive atmosphere in which I could conclude this work and for facilitating its publication.

For the numerous discussions and a great time, I am grateful to my E 24 colleagues Dr. Michael Preiss, Christian Bürgin, Dr. Aurel Kunz, and Dr. Rok Sekolec. Besides, I would like to thank Dr. Luca Bongulielmi, Martin Gunzenhauser, Michael Marti, Dag Bergsjö, Amer Catic, and all those not mentioned here. Finally, I am also grateful to the people at my industrial partners that I collaborated with as part of my research project.

Special thanks go to my family for their enduring support. My personal gratitude goes to Frauke.

Zurich, November 2006

Björn Avak

Table of Contents

List of Abbreviations	VIII
Abstract	IX
Zusammenfassung	X
1 Introduction	1
1.1 Background	1
1.2 Motivation and Research Approach	3
1.2.1 Motivation	3
1.2.2 Research Approach	5
1.3 Research Objectives and Outline	7
1.3.1 Research Objectives	7
1.3.2 Delimitations	7
1.3.3 Outline	8
2 Positioning within Design Science	11
2.1 Innovation	12
2.1.1 Objectives of Innovation	13
2.1.2 Process of Innovation	15
2.1.3 Outcomes of Innovation	18
2.1.4 Positioning with Respect to Innovation	20
2.2 Variant Management	21
2.2.1 Levels of Variant Management	22
2.2.2 Approaches of Variant Management	23
2.2.3 Positioning with Respect to Variant Management	25
2.3 Product Structuring	25
2.3.1 Approaches of Product Structuring	26
2.3.2 Types of Product Structures	27
2.3.3 Phases of Product Structuring	32
2.3.4 Positioning with Respect to Product Structuring	34
2.4 Overall Positioning and Definition	34

3 Requirements and Related Work	37
3.1 Requirements	37
3.1.1 Safeguard Key Properties	38
3.1.2 Evaluate and Improve Concepts	40
3.1.3 Requirements List	41
3.2 Related Work	42
3.2.1 Methods for Safeguarding Key Properties and Evaluation/Improvement	43
3.2.2 Methods for Safeguarding Key Properties	48
3.2.3 Methods for Evaluation/Improvement	57
3.3 Research Gap	63
3.4 Research Question	65
4 Variant Management Funnel	66
4.1 Outline of Variant Management Funnel	66
4.2 Framework for Modular Product Families	70
4.2.1 Tool	70
4.2.2 Illustrative Example	75
4.2.3 Implementation	76
4.3 Module Sheets	78
4.3.1 Tool	78
4.3.2 Illustrative Example	81
4.3.3 Implementation	82
4.4 Probabilistic Evaluation and Improvement	83
4.4.1 Tool	83
4.4.2 Illustrative Example	98
4.4.3 Implementation	102

5 Case Examples	105
5.1 Case Example 1 - Railway Signals	105
5.1.1 Company Context	105
5.1.2 Implementation	106
5.1.3 Use	113
5.2 Case Example 2 - Liquid Handling Systems	117
5.2.1 Company Context	117
5.2.2 Implementation	118
5.2.3 Use	124
6 Validation	129
6.1 Theoretical Structural Validation	130
6.1.1 Validation of Individual Tools	131
6.1.2 Validation of Overall Structure	135
6.2 Empirical Structural Validation	136
6.3 Empirical Performance Validation	139
6.4 Theoretical Performance Validation	142
6.4.1 Limitations	143
6.4.2 Range of Validity	146
7 Summary and Outlook	149
7.1 Summary	149
7.2 Outlook	151
References	152

List of Abbreviations

BOM	Bill of material
CAD	Computer-aided design
CHF	Swiss franc
CN	Customer need
CVaR	Conditional value-at-risk
DSM	Design structure matrix
DP	Design parameter
ERP	Enterprise resource planning
FR	Functional requirement
IT	Information technology
LED	Light-emitting diode
MFD	Modular function deployment
PLM	Product lifecycle management
PV	Process variable
R&D	Research and development
SCM	Supply chain management
SOP	Standard operating procedure
UML	Unified modeling language
VBA	Visual basic for applications
VMEA	Variant mode and effects analysis

Abstract

The *variant management funnel* proposed in this work is a method to sort out, evaluate, and improve concepts for new modules and module variants in the market phase of an existing modular product family.

Although modular product families are broadly applied in industry today, they are generally not properly managed in their market phase. The key properties of a modular product family, namely its product structure and interfaces, are not safeguarded. Numerous additional modules and module variants are introduced in the market phase of the product family. Many of these new modules and module variants are very expensive in following phases of the innovation process, e.g. development or manufacturing. That is why in the variant management funnel, concepts for new modules and module variants have to pass two screens.

- *Compatibility screen*: It is checked if the concepts are compatible with the existing modular product family in terms of product structure and interfaces. This is done with the help of two tools. The *framework for modular product families* is a tool to capture the product structure of a modular product family using UML. *Module sheets* are a tool to capture interfaces and related information for all modules. All concepts that do not pass the compatibility screen are either discarded or reworked.
- *Stakeholder screen*: The remaining concepts are evaluated and improved by means of the effects they have on various stakeholders within the corporation. The *probabilistic evaluation and improvement* tool allows the decision maker to model these effects using probability distributions of decision criteria such as cash flow and amount of work. Depending on the properties of a concept, the resulting effects will look different. Concepts are therefore characterized by a set of properties. Concepts are evaluated and improved by calculating expected value and risk of the decision criteria for the respective set of properties. The calculation is facilitated by an Excel-based VBA application.

The variant management funnel was developed and applied in the scope of an applied research project with industry. Two case examples describing implementation and use at the industrial companies are provided.

Zusammenfassung

Der im Rahmen dieser Arbeit vorgestellte *Variant Management Funnel* wird in der Marktphase einer bestehenden modularen Produktfamilie eingesetzt, um erfolgversprechende Konzepte für neue Module und Modulvariante herauszufiltern.

Modulare Produktfamilien sind heute in der Industrie weitverbreitet. Dabei werden modulare Produktfamilie in ihrer Marktphase oft falsch gehandhabt. Die Kerneigenschaften einer modularen Produktfamilie, d.h. Produktstruktur und Schnittstellen, werden bei der Entscheidung über neue Module und Modulvarianten oft missachtet. Viele der neu eingeführten Module und Modulvarianten sind in nachgelagerten Prozessen wie Entwicklung und Fertigung sehr aufwendig. Daher durchlaufen Konzepte für neue Module und Modulvarianten im Variant Management Funnel zwei Filter.

- *Kompatibilitäts-Filter*: Der Entscheidungsträger überprüft, ob die vorgeschlagenen Konzepte hinsichtlich Produktstruktur und Schnittstellen kompatibel sind. Dies wird durch zwei Werkzeuge unterstützt. Mit diesen wird einerseits die Produktstruktur der modularen Produktfamilie visuell in UML dargestellt. Andererseits werden Schnittstellen zwischen Modulen auf Modulblättern spezifiziert. Konzepte, die den Kompatibilitäts-Filter nicht passieren, werden verworfen oder überarbeitet.
- *Stakeholder-Filter*: Die übrig gebliebenen Konzepte werden anhand der durch sie verursachten Effekte bewertet und verbessert. Effekte können in allen Abteilungen des Unternehmens auftreten. Die Effekte werden als Wahrscheinlichkeitsverteilungen von Entscheidungskriterien, z.B. Cash Flow oder Arbeitsaufwand, modelliert. Je nach Eigenschaften eines Konzeptes fallen diese Effekte anders aus. Deshalb werden Konzepte anhand ihrer Eigenschaften bewertet und verbessert. Aus den Eigenschaften werden Erwartungswert und Risiko der Entscheidungskriterien berechnet. Die Berechnung wird durch ein Excel-basiertes VBA Programm durchgeführt.

Der Variant Management Funnel wurde im Rahmen eines angewandten Forschungsprojektes mit der Industrie entwickelt. Es wird in zwei Fallbeispielen von Industrieunternehmen aus diesem Projekt beschrieben, wie der Variant Management Funnel implementiert und genutzt wurde.

Chapter 1

Introduction

1.1 Background

The management of complexity is a key success factor in leading an industrial company¹. On the one hand, it is necessary to satisfy the range of customer needs determining external complexity. On the other hand, internal complexity of the company needs to be minimized to save costs². This is not a static problem as external complexity is constantly rising. There are three main reasons for this development³.

- *Globalization of companies*: In order for companies to be competitive, it is becoming necessary to be present in all major markets. As a result, the requirements of customers with different cultural, technological, economic, and legal backgrounds need to be incorporated in products.
- *Technological evolution*: Technology is evolving at an ever-increasing pace⁴. The frequency at which new products are being brought to the market is increasing⁵. This trend is further enhanced by the convergence of technologies⁶.
- *Increasing customer market power*: The influence of the customer to determine a product's features and price is increasing. This reflects in the fact that manufacturers are providing more and more product variants to suit the wishes of individual

1. [Rommel, 1993], p. 2, [Malik, 1996], p. 170, [Puhl, 1999], p. 1.

2. [Child et al., 1991], p. 74, 75, [Kaiser, 1995], p. 101.

3. [Clark and Wheelwright, 1993], p. 4 identify international competition, diverse and rapidly changing, and fragmented and demanding markets as key drivers.

4. [Gemünden, 1993], pp. 72, 73.

5. [Bayus, 1994], p. 306, [Pleschak and Sabisch, 1996], p. 12.

6. [Poole and Simon, 1997], p. 240.

customers⁷. This is particularly true in the case of faltering markets, where the number of variants increased between 400% and 600% in the years from 1980 to 2002 as opposed to between 250% and 350% in growth markets⁸.

As shown in Figure 1-1, numerous methods and tools have been introduced in the past century to limit the impact of rising external complexity onto internal complexity in manufacturing, information management, and processes.

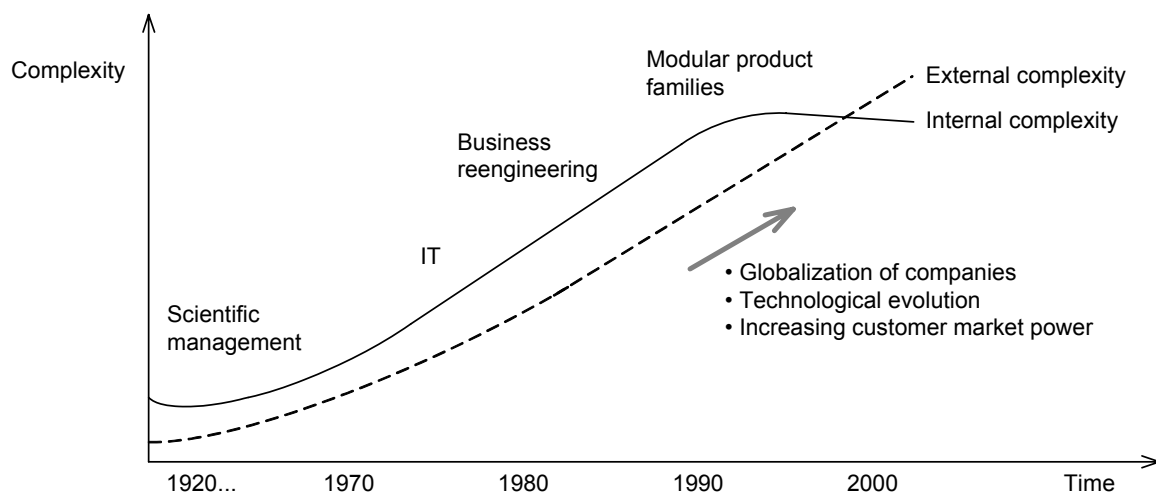

Figure 1-1: Evolution of complexity, based on ERICSSON & ERIXON⁹

Taylor introduced scientific management in the early 20th century to efficiently set up manufacturing. Starting in the 1970s, information technology (IT) tools such as CAx and product lifecycle management (PLM) systems were applied to efficiently generate and administrate vast amounts of data. In the 1980s, business reengineering emerged as an approach to streamline corporate processes. These methods and tools have been successful in fighting some of symptoms of complexity. Still, they do not target the source of internal complexity in the company, i.e. the product.

It is the product that mostly determines manufacturing, information to be managed, and corporate processes. The product is at the interface between external and internal complexity. In applying modular product families, one consciously defines the modules and module variants

7. [Franke et al., 2002], p. 1, [Wiendahl, 2004], pp. 3, 4.

8. [Kunz, 2005], p. 2.

9. [Ericsson and Erixon, 1999], p. 2.

making up a product family and clearly specifies the interfaces between these modules. The potential utility of modular product families is enormous¹⁰ and they are broadly used¹¹. Still, in order to reap these benefits, one needs to address modular product families from a holistic perspective. A modular product family needs to be managed across its entire lifecycle in consideration of all stakeholders in the company involved in its development and realization. That is why variant management of modular product families in the market phase needs to be addressed.

1.2 Motivation and Research Approach

The initial development of modular product families is extensively discussed in the literature¹² and many methods are applied in industry¹³. It is, however, not sufficient to consider the initial development phase alone. The market phase of a modular product family, i.e. the time frame over which it is sold on the market, is significantly longer than for a single product. It needs to be treated with appropriate diligence. The motivation for carrying out research on variant management of modular product families in the market phase is provided in this section.

This work is to be associated with the applied sciences according to ULRICH¹⁴. The motivation for this type of research comes from problems in industry. In order to legitimate research, it is therefore necessary to first identify the industrial motivation for this topic and then proceed in a structured manner.

1.2.1 Motivation

Modular product families are a topic of tremendous industrial importance and have been applied in virtually all industries. Applications cover products as diverse as printers¹⁵, automotive components¹⁶, and power tools¹⁷. With so many modular product families now being in place,

10. [Rapp, 1999], p. 1, [Franke et al., 2002], p. 133, [Sekolec, 2005], p. 33.

11. [Simpson, 2004], p. 5.

12. [Gershenson et al., 2003], pp. 295-303 identify more than fifty different references related to the definition of modularity alone.

13. [Baldwin and Clark, 1997], pp. 84-88.

14. [Ulrich, 1984], pp. 192-195 gives a generic framework for applied research.

15. [Feitzinger and Lee, 1997], p. 117.

16. [Wilhelm, 1997], p. 147, [Erixon, 1998], p. 2.

there is a need to effectively manage these product families in the market phase. The following observations from industry, however, indicate that this is not the case.

- *Unsuitable methodologies used:* Modular product families require a different approach to variant management than single products. Interfaces and interactions among modules, for instance, rise to critical importance¹⁸. Although there is growing awareness of this issue in many companies, methods to face up to this challenge have not yet been implemented¹⁹. Modular product families are treated with the same mechanisms, e.g. single product development and change management, as single products. A dedicated structure to deal with modular product families in the market phase is not in place.
- *Increasing number of variants:* Despite the broad use of modular product families, the number of variants continues to rise unabated in most companies. This very often happens without consideration of the utility of additional variants, leading to a continuous increase in overhead costs²⁰. SCHUH²¹ shows that in many companies, the market is initially entered with a small and focused product portfolio. In an attempt to increase or maintain sales in the market phase, the portfolio is constantly enlarged. In the course of this process, new variants are introduced²². Due to cannibalization effects²³, new variants often do not substantially increase sales but only lead to a redistribution from standard to special products. As shown in Figure 1-2, the sales curve flattens out. Special products generally cause higher overhead costs that cannot be captured using traditional accounting methods. As a result, increased costs are not passed on to the selling price and the profit margin decreases.

17. [Sudjianto and Otto, 2001], p. 4.

18. [Blackenfelt, 2001], p. 36 states that 'interfaces are the core of modularisation.' [Andreasen et al., 2004], p. 81 identify the relative independence of modules through the establishment of interfaces as one of the key properties of modular product families. [Sundgren, 1999], p. 41 states that interfaces are a key success factor in product families.

19. [Meyer et al., 1997], p. 107 observe that processes and methods in most companies are still geared towards single products although this is very often detrimental. [Preiss et al., 2006], pp. 5, 6 find out through interviews that more companies need support in the market phase than in initially setting up a product family.

20. [Schuh, 2005], p. 16.

21. [Schuh, 2005], pp. 19, 20.

22. [Friedrich, 2004], p. 1., [Kaiser, 1995], p. 2, [Sekolec, 2005], p. 2.

23. [Child et al., 1991], p. 75, [Hill and Rieser, 1993], p. 255, [Heina, 1999], p. 28.

- *Insufficient decision basis*: Decisions in variant management have far-reaching effects at all corporate stakeholders involved in product realization²⁴. Many of these are complexity effects²⁵ that cannot be captured using traditional accounting techniques, e.g. overhead calculation. This widely-used method can be very misleading when it comes to decisions in variant management²⁶. There also is a lack of technical knowledge on the consequences²⁷.

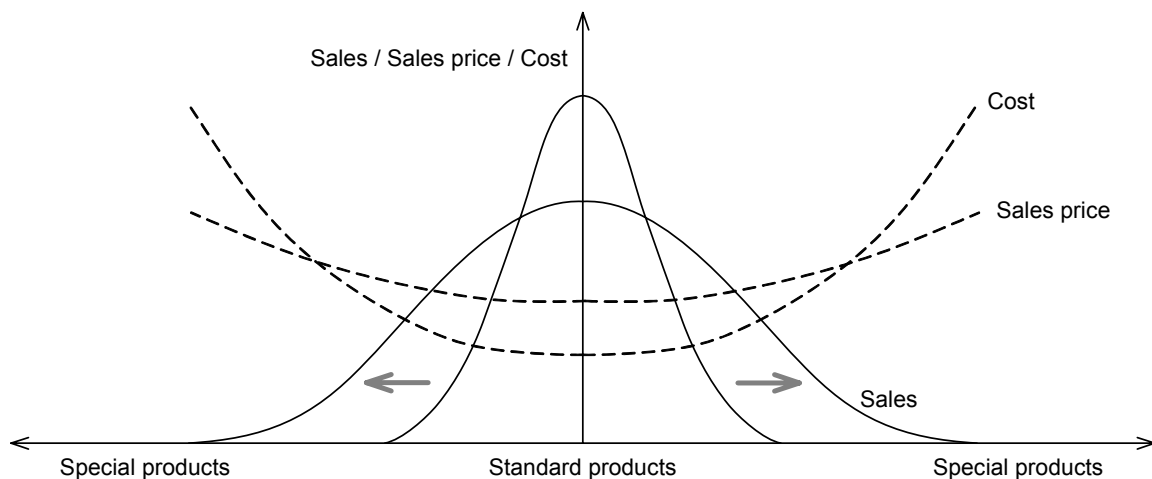

Figure 1-2: Evolution of product portfolio over time, based on SCHUH²⁸

Due to these difficulties, companies wish for a structured method to variant management of modular product families in the market phase. It has been observed through interviews that more than half of the companies interviewed wish for such a method²⁹. This method should help structure the problem, control the number of variants, and clarify the effects of decisions in variant management of modular product families in the market phase.

1.2.2 Research Approach

The challenge of variant management of modular product families in the market phase was first identified by the author at a manufacturer of semiconductor equipment. By talking to

24. [Rathnow, 1993], p. 24.

25. Complexity effects are defined as the consequences of variety in the product portfolio, see [Homburg and Daum, 1997], p. 333.

26. [Rommel, 1993], pp. 25, 26.

27. [Mesihovic and Malmvist, 2004], p. 4.

28. [Schuh, 2005], p. 20.

29. [Preiss et al., 2006], p. 6.

representatives from other companies, it was recognized that several companies face this challenge. Additionally, interviews were carried out with ten heads of development and technical directors of Swiss companies to check for broader relevance³⁰. Subsequently, a two-year applied research project was set up. This project involved three industrial companies, one consulting company, and ETH Zurich. It was funded partially by industry, partially by the Swiss Confederation's innovation promotion agency. The project was managed by the author. In the scope of this project, requirements for a method to support variant management of modular product families in the market phase were elaborated in collaboration between industry and ETH. The method was developed at ETH and then implemented at the industrial companies.

Research in the context of applied sciences starts with problems encountered in practice³¹. According to ULRICH³², applied research should follow a structured approach. This consists of first identifying the problem in practice, then assessing existing theories in research, providing models and support for the identified problems, and finally checking models and support through practical application. Research should therefore be industrially relevant, new, complement existing research, and proceed systematically.

It is concluded that the research presented here should fulfill the following requirements.

1. *Industrial relevance*: It has been shown in Subsection 1.2.1 and this subsection that the topic of variant management of modular product families in the market phase currently represents a challenge in industry.
2. *Novelty*: The requirements for a method to support variant management of modular product families in the market phase are elaborated in Chapter 3. Existing methods are assessed based on these requirements. The variant management funnel, which is the method proposed here, is novel in that it is the first to fulfill these requirements.
3. *Clear positioning*: In Chapter 2, variant management of modular product families in the market phase is positioned with respect to relevant fields within design science.
4. *Systematic approach*: The systematic approach here is to first state the problem, then position the problem within research, and identify the research gap. The research question is stated next and an answer is provided, which is then implemented and evaluated. This is further described in Subsection 1.3.3.

30. [Preiss et al., 2006], pp. 107, 108.

31. [Popper, 1979], p. 104.

32. [Ulrich, 1984], p. 193.

1.3 Research Objectives and Outline

1.3.1 Research Objectives

The industrial challenges have been described in Subsection 1.2.1. The intention is to provide an answer to these challenges through research. This can be broken down into an academic and an industrial objective.

- *Academic objective - Structure topic academically:* Variant management of modular product families has not been clearly defined yet. The objective here is to position this topic within research, define it, analyze industrial needs, and evaluate existing research.
- *Industrial objective - Provide decision support:* Decisions in variant management of modular product families in the market phase deal with launching new modules and module variants. These decisions are currently made in an ad hoc manner. A method is to be provided that can be applied rapidly to limit the increase of new modules and module variants to only useful ones. Using this method, the decision maker should be able to quantitatively estimate and visualize the effects resulting from a decision in variant management of modular product families in the market phase. Such a method, which should also require few resources for implementation and use, is to be provided in this work.

1.3.2 Delimitations

The following aspects are consciously not treated in the scope of this work.

- *Initial development of a modular product family:* There is extensive coverage in the literature of methods that can be applied to initially develop a modular product family. The most important ones are described in Subsection 2.3.2. These methods already cover most applications. It is therefore presumed here that one of these methods may be used to initially develop a modular product family. The focus here is on effective variant management of an already existing modular product family in the market phase.
- *Variant reduction and handling:* In variant reduction, existing low-volume variants are eliminated from the product portfolio in an attempt to reduce overhead costs³³. Variant handling consists of efficiently dealing with a given product portfolio in the

company without changing the the product portfolio itself. Common approaches within variant handling³⁴ are organizational development, shifting of the customer order decoupling point³⁵, outsourcing, and flexible manufacturing. Both variant reduction and handling require very different approaches than what is discussed in this work and are not treated here.

- *Product family simplification*: This is similar to variant reduction as it involves the elimination of redundant or unprofitable variants. For the same reasons as variant reduction, it is not considered.
- *Variant strategy*: The variant strategy described in Subsection 2.2.1 determines the products to be offered beyond the lifecycle of a single product family. It is closely related to the product strategy, which is introduced in Subsection 2.1.1. Since this work is positioned within operative variant management, it is assumed that the variant strategy is given and can be translated into concrete, quantifiable objectives. The determination of a variant strategy is not discussed here as it is the topic of related literature³⁶.

1.3.3 Outline

The above research objective is pursued in a structured manner as shown in the outline in Figure 1-3.

In *Chapter 1*, the business background promoting the use modular of product families is described. The industrial motivation and the research approach for variant management of modular product families in the market phase are characterized. The resulting research objectives are stated.

Chapter 2 serves to present the fundamentals from design science that are the basis of this work. These fundamentals originate from innovation, variant management, and product structuring. They span a theoretical coordinate system that is used to position and define variant management of modular product families in the market phase.

33. [Heina, 1999], pp. 51-53.

34. [Heina, 1999], pp. 53-56.

35. This is the point in the value chain that separates process steps that are standardized and independent of the customer from varying, customer-dependent activities, see [Rudberg and Wikner, 2004], pp. 447-449.

36. [Heina, 1999], p. 40, [Rathnow, 1993], pp. 185-197, [Kaiser, 1995], pp. 106-121.

Problem	<p style="text-align: center;">Chapter 1 <i>Introduction</i></p> <div style="display: flex; justify-content: space-around;"> <div style="border: 1px solid black; padding: 2px; width: 45%;">Background</div> <div style="border: 1px solid black; padding: 2px; width: 45%;">Motivation</div> </div> <div style="display: flex; justify-content: space-around; margin-top: 5px;"> <div style="border: 1px solid black; padding: 2px; width: 45%;">Research approach</div> <div style="border: 1px solid black; padding: 2px; width: 45%;">Research objectives</div> </div>
Classification	<p style="text-align: center;">Chapter 2 <i>Positioning within Design Science</i></p> <div style="display: flex; justify-content: space-around;"> <div style="border: 1px solid black; padding: 2px; width: 45%;">Innovation</div> <div style="border: 1px solid black; padding: 2px; width: 45%;">Variant management</div> </div> <div style="border: 1px solid black; padding: 2px; text-align: center; margin-top: 5px;">Product structuring</div> <div style="border: 1px solid black; padding: 2px; text-align: center; margin-top: 5px;">Definition</div>
Research gap	<p style="text-align: center;">Chapter 3 <i>Requirements and Related Work</i></p> <div style="border: 1px solid black; padding: 2px; text-align: center; margin-bottom: 5px;">Requirements</div> <div style="border: 1px solid black; padding: 2px; text-align: center; margin-bottom: 5px;">Related work</div> <div style="display: flex; justify-content: space-around;"> <div style="border: 1px solid black; padding: 2px; width: 45%;">Research gap</div> <div style="border: 1px solid black; padding: 2px; width: 45%;">Research question</div> </div>
Research contribution	<p style="text-align: center;">Chapter 4 <i>Variant Management Funnel</i></p> <div style="display: flex; justify-content: space-around;"> <div style="border: 1px solid black; padding: 2px; width: 45%;">Framework for modular product families (compatibility screen)</div> <div style="border: 1px solid black; padding: 2px; width: 45%;">Module sheets (compatibility screen)</div> </div> <div style="border: 1px solid black; padding: 2px; text-align: center; margin-top: 5px;">Probabilistic evaluation and improvement (stakeholder screen)</div>
Implementation	<p style="text-align: center;">Chapter 5 <i>Case Examples</i></p> <div style="display: flex; justify-content: space-around;"> <div style="border: 1px solid black; padding: 2px; width: 45%;">Company context</div> <div style="border: 1px solid black; padding: 2px; width: 45%;">Implementation</div> </div> <div style="border: 1px solid black; padding: 2px; text-align: center; margin-top: 5px;">Use</div>
Evaluation	<p style="text-align: center;">Chapter 6 <i>Validation</i></p> <div style="display: flex; justify-content: space-around;"> <div style="border: 1px solid black; padding: 2px; width: 45%;">Theoretical structural validity</div> <div style="border: 1px solid black; padding: 2px; width: 45%;">Theoretical performance validity</div> </div> <div style="display: flex; justify-content: space-around; margin-top: 5px;"> <div style="border: 1px solid black; padding: 2px; width: 45%;">Empirical structural validity</div> <div style="border: 1px solid black; padding: 2px; width: 45%;">Empirical performance validity</div> </div>
Conclusion	<p style="text-align: center;">Chapter 7 <i>Summary and Outlook</i></p> <div style="display: flex; justify-content: space-around; margin-top: 10px;"> <div style="border: 1px solid black; padding: 2px; width: 45%;">Summary</div> <div style="border: 1px solid black; padding: 2px; width: 45%;">Outlook</div> </div>

Figure 1-3: Outline

The requirements of a proposed method for variant management of modular product families in the market phase are elaborated in *Chapter 3*. Existing methods from the literature are described and evaluated against these requirements. The discrepancy between the requirements and their fulfillment by existing methods represents the research gap to be closed with this work.

In *Chapter 4*, the variant management funnel is described. This is the method that is intended to close the research gap. It consists of a development funnel with two screens. Within these screens, concepts for new modules and module variants are discarded, evaluated, and improved. In the first screen, called compatibility screen, concepts for new modules that are not compatible with the existing modular product family's product structure and interfaces are discarded using two tools. The framework for modular product families is applied, which is a visual representation of the modular product family's product structure. This tool is described in Section 4.2. The interfaces with the rest of the modular product family are checked using module sheets, which are introduced in Section 4.3. In the second screen, called stakeholder screen, the remaining concepts are evaluated and improved for multiple decision criteria through probabilistic evaluation and improvement. This tool is described in Section 4.4. Each of the tools of the method is explained in detail and an illustrative example is given. The implementation process is also described.

The method for variant management of modular product families in the market phase was developed, implemented, and used in the scope of an applied research project. Two case examples of how the method has been implemented and used at industrial companies are provided in *Chapter 5*.

Chapter 6 serves to validate the proposed method. This is carried out by using the so-called validation square³⁷. The variant management funnel is taken through several steps in which its internal consistency, the appropriateness and outcomes of the case examples from Chapter 5, and its utility beyond the case examples and original requirements are assessed.

A summary of the entire work is provided in *Chapter 7*. Moreover, avenues for future research are shown up.

37. [Pedersen et al., 2000], pp. 4-6.

Chapter 2

Positioning within Design Science

The work presented here belongs to design science. According to HUBKA & EDER³⁸, design science ‘is to be understood as a system of logically related knowledge, which should contain and organize the complete knowledge about and for designing.’ This knowledge is a combination of endemic knowledge as well as from other disciplines such as management, mathematics, and information science³⁹. Within design science, variant management of modular product families in the market phase is at the intersection of innovation, variant management, and product structuring. This is shown in Figure 2-1.

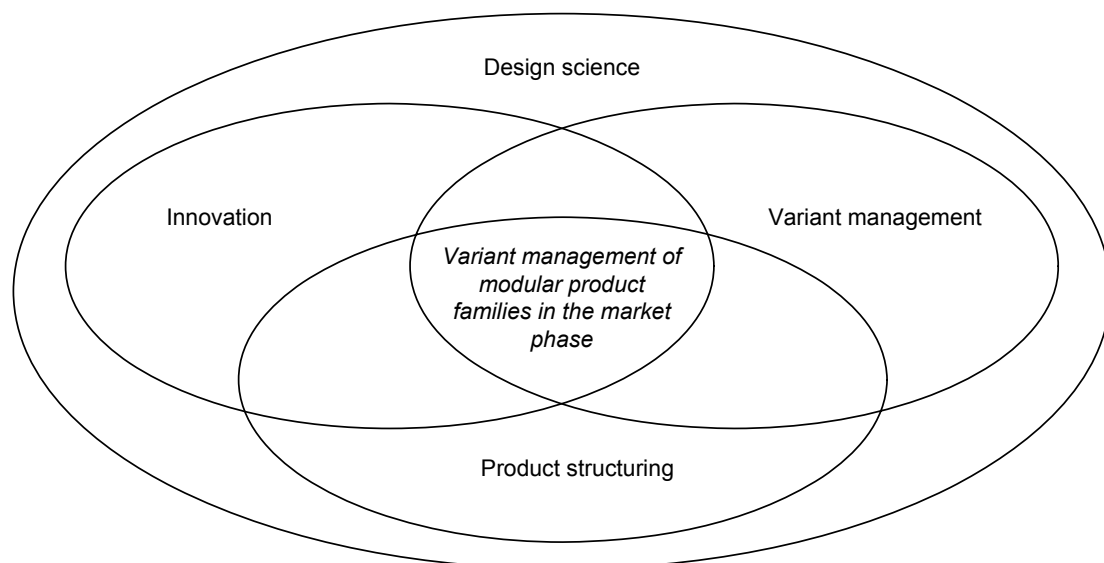

Figure 2-1: Relevant fields of design science

These three fundamental fields are necessary to understand the following chapters and variant management of modular product families in the market phase as a whole. That is why the key concepts from innovation are presented in Section 2.1, from variant management in Section 2.2,

38. [Hubka and Eder, 1996], p. 73.

39. [Hubka and Eder, 1996], pp. 90-93.

and from product structuring in Section 2.3. It is described in each respective section which of these concepts are relevant for variant management of modular product families in the market phase. In Section 2.4, variant management of modular product families in the market phase is positioned with respect to these fields. The final result is a definition of variant management of modular product families in the market phase.

2.1 Innovation

This section serves to characterize innovation in terms of its objectives, process, and concrete outcomes. Variant management of modular product families in the market phase is positioned with respect to these aspects. Innovation is probably among the most prominent buzzwords of recent years. While in the past, the notion of innovation was used in different fields with very specific meaning, it is now applied very broadly⁴⁰. Innovation is defined here as the process of commercializing a perceivably new product or process⁴¹. This definition can be decomposed into the following three parts.

1. *Innovation is the commercialization of inventions*: Ideas for new products and processes are continuously generated in a corporation. Innovation is the successful marketing of these ideas, thus contributing to the business objectives.
2. *Innovation is a process*: Innovation is a process consisting of different phases and steps to investigate, develop, and adopt new products and processes.
3. *Innovation is a perceivably new product or process*: An innovation is a product or process that is perceived as being new by an individual or a group.

In terms of variant management of modular product families in the market phase, it is therefore important that innovation serves business objectives, is a process, and results in perceivably new products and processes. These three aspects are discussed in the following subsections.

40. [Mitterdorfer-Schaad, 2001], pp. 13-15 shows how the notion of innovation has become broader over the past decades.

41. [Hauschildt, 2004], pp. 4-6.

2.1.1 Objectives of Innovation

Innovation is no end in itself. It has to serve the business objectives⁴² and foster corporate development. As summarized in Figure 2-2, the corporate development is determined on three levels of management in the company⁴³.

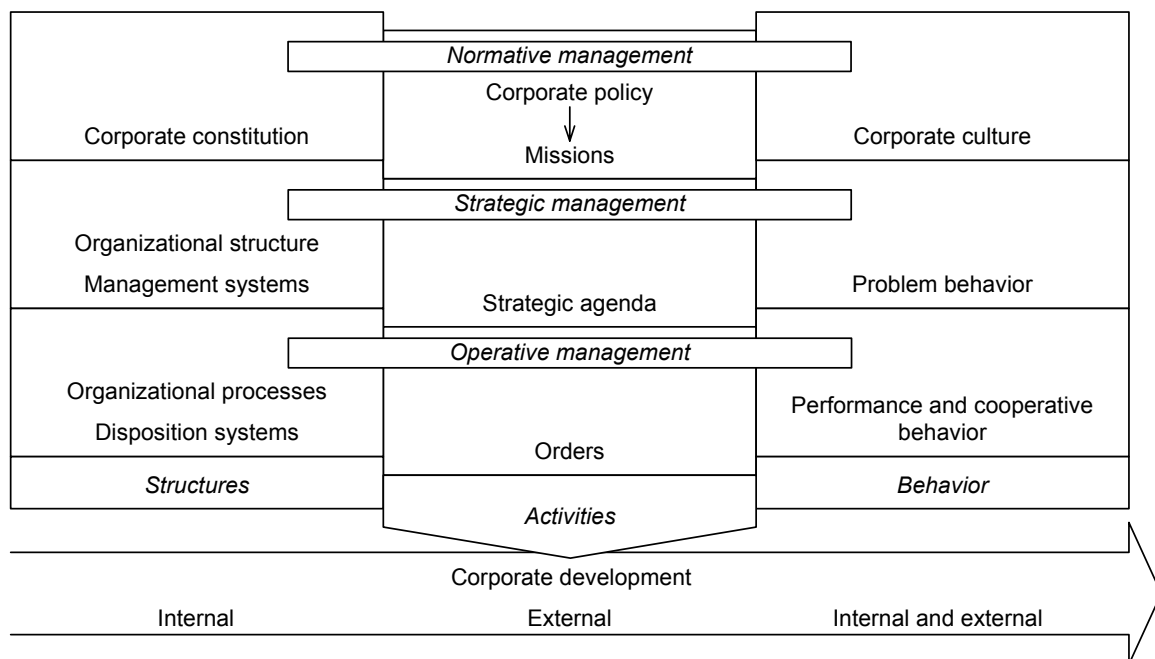

Figure 2-2: Levels of management, based on BLEICHER⁴⁴

Normative management deals with the general objectives of the corporation and its principles. In terms of structures, normative management decides on the corporate constitution. Besides, normative management determines the corporate culture and corporate policy. Corporate policy has a constitutive role and results in missions that should legitimate all other actions in the corporation.

Strategic management focuses on the development, nurturing, and exploitation of corporate capabilities. Resources have to be allocated for that purpose. The primary activity in strategic management is the determination of a strategic agenda. This agenda is characterized by four dimensions⁴⁵. These are the product strategy, the competitive strategy, the activity strategy, and

42. [Pleschak and Sabisch, 1996], p. 8.

43. This goes back to the St. Gallen management model, see [Ulrich, 1984], pp. 329-333, [Tschirky, 1998], pp. 221-225, and [Bleicher, 2004], pp. 78-86.

44. [Bleicher, 2004], p. 83.

the resource strategy. In the context of this research, the product strategy is most important. Product strategy comprises decisions on the markets, market segments, and market niches in which the corporation chooses to be active. Besides, the extent to which the customer is allowed to influence product realization is decided on at this level⁴⁶. The outcome of this decision determines whether the customer will be provided with standardized or customized solutions.

The translation of normative and strategic management into concrete actions takes place in *operative management*. Typical inputs from strategic management to be implemented in operative management are earnings and sales targets or specifications from manufacturing and quality assurance⁴⁷. It is assumed in this context that these inputs are given to the decision maker in variant management of modular product families. The decision maker only needs to ensure that the objectives are fulfilled. Variant management of modular product families in the market phase is therefore part of operative management. Objectives are decision criteria with respective target values. They are given by strategic management. Concrete steps to reach the target values are taken in operative management.

All objectives can be characterized using three dimensions⁴⁸. As shown in Figure 2-3, these are the outcome of an innovation in terms of benefit to the customer and quality, the effort for realizing the innovation, and the timing of the innovation, both in terms of the amount of time for the innovation to take place and its point in time. Objectives can also be characterized by efficiency, productivity, and intensity, which are the respective ratios of two out of the three previously mentioned aspects.

45. See [Bleicher, 2004], pp. 307-223 for detailed definitions and examples for the four dimensions of the strategic agenda.

46. This is closely related to the customer order decoupling or order penetration point, see [Rudberg and Wikner, 2004], pp. 447-449.

47. [Tschirky, 1998], p. 224.

48. [Pleschak and Sabisch, 1996], p. 9.

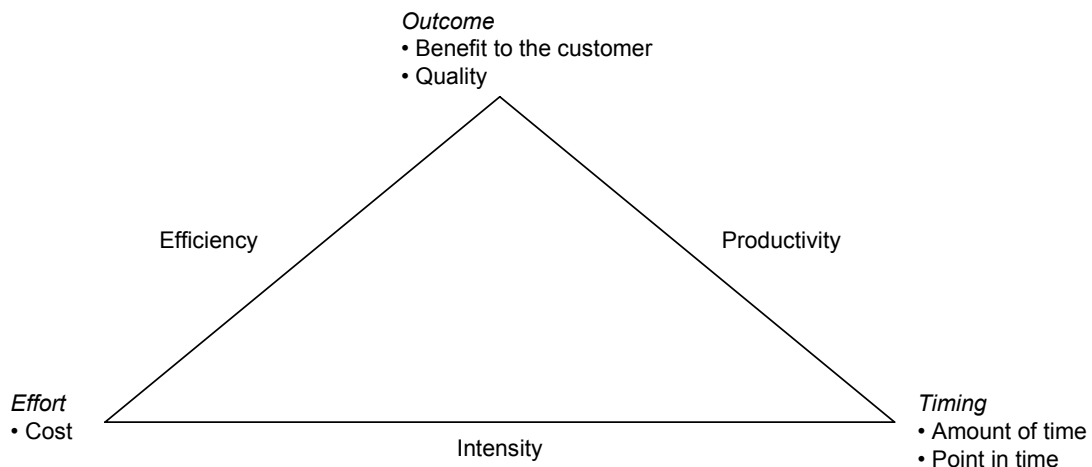

Figure 2-3: *Triangle of objectives in innovation, based on PLESCHAK & SABISCH*⁴⁹

2.1.2 Process of Innovation

A structured innovation process is an important success factor for a corporation⁵⁰. Historically, the innovation process evolved from the process of engineering design. The most important work in this area is PAHL & BEITZ⁵¹. The authors define engineering design as the four-phase process shown in Figure 2-4.

In the *clarification of task* phase, guidelines for the search for new products are established and the market is analyzed. A preliminary requirements list and a cost target are established. The final aim in this phase is to come up with the requirements list, which is needed throughout the following phases of the design process. The requirements list should contain requirements and wishes but no fixed solutions.

Conceptual design consists of four steps, i.e. abstraction, establishment of function/working structures, and the development of concepts. Abstraction helps see the problem from an unbiased point of view. Subsequently, the design problem is framed as a function structure and working principles for the individual functions are searched for. The outcome of conceptual design is the combination of functions with suitable working principles, which is called a concept.

49. [Pleschak and Sabisch, 1996], p. 9.

50. [Cooper, 2002], p. 123.

51. [Pahl and Beitz, 1996].

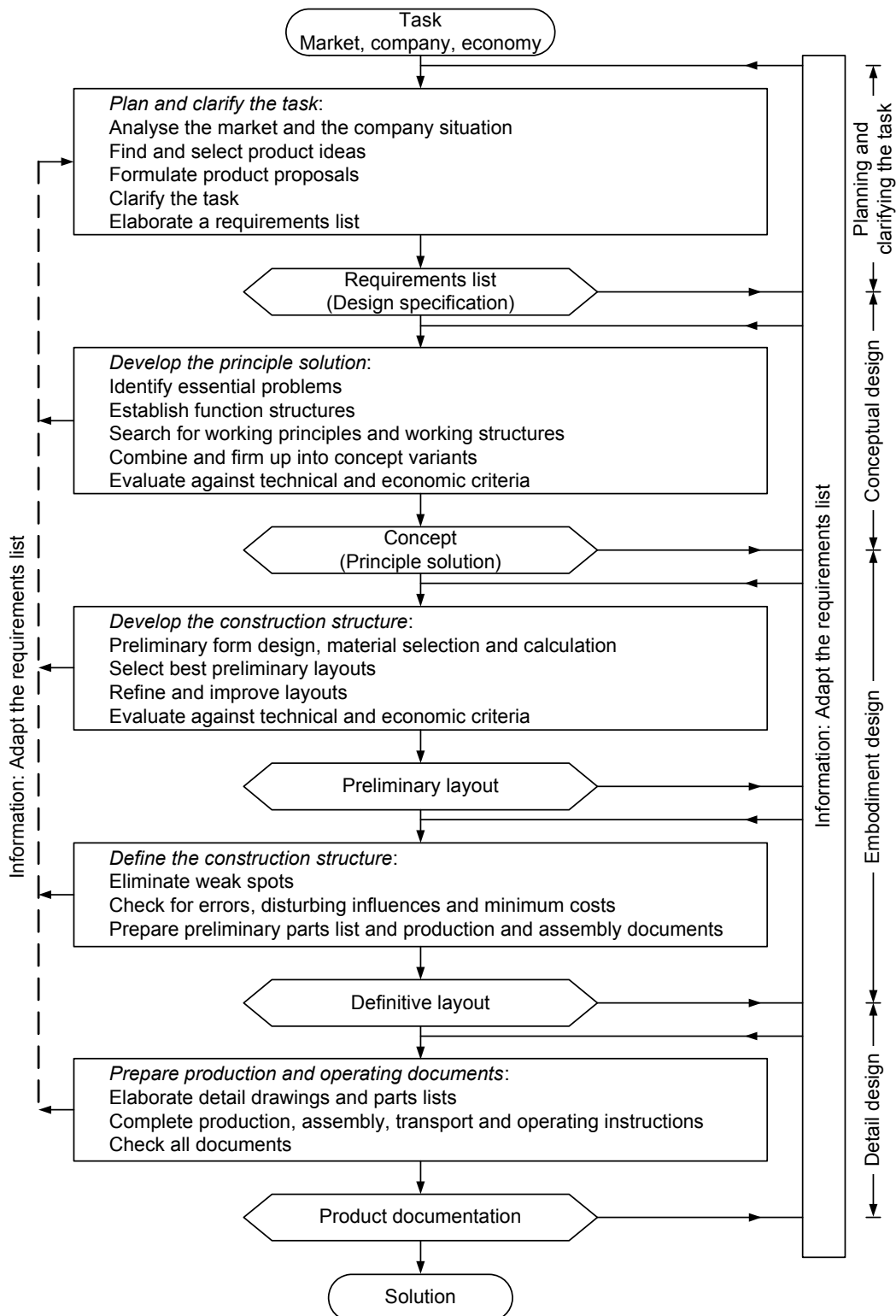

Figure 2-4: Engineering design process, according to PAHL & BEITZ⁵²

52. [Pahl and Beitz, 1996], p. 66.

In *embodiment design*, the definitive layout of the product is created. A shift from qualitative to quantitative and from abstract to concrete knowledge takes place. Embodiment design results in the definitive layout of the product.

Detail design is the final phase of an engineering design project and comprises the completion of production documentation and finalization of the definitive layout. Detail design leads to the complete documentation required to manufacture a product.

The engineering design process by PAHL & BEITZ is a work of reference that strongly influenced the way engineering design is carried out today⁵³. There are, however, two important limitations to it.

- *Single product development*: PAHL & BEITZ merely consider the interrelationships among different products from a market perspective. This is done in the planning and clarifying the task phase, where one strives to ensure that the new product does not cannibalize existing ones. The consideration of potential interrelationships among products does, however, not go beyond this basic level. They do not cover the benefits of shifting to multi-product development, e.g. through product families and platforms. Although this may have been feasible at the time the PAHL & BEITZ engineering design process was set up, this is no longer the case. Multi-product development⁵⁴ is at the order of the day, so approaches are required to coordinate the development of multiple products.
- *Little consideration of downstream processes*: Although PAHL & BEITZ mention downstream activities like manufacturing and supply chain management, their process stops with the release of product documentation. The consideration of downstream activities is, however, essential in order to successfully bring products to market⁵⁵.

These limitations are compensated by innovation processes. As shown in Figure 2-5, innovation processes are much broader in scope. According to ROOZENBURG & EEKELS⁵⁶, the innovation process can be divided into the product planning, strict development, and realization phases.

53. This can be seen by looking at the VDI guidelines [VDI2221, 1990], p. 9 and [VDI2222-1, 1997], p. 3.

54. [Andreasen et al., 2004], p. 75.

55. [Paashuis, 1998], pp. 4, 5.

56. [Roozenburg and Eekels, 1995], p. 13.

PAHL & BEITZ only cover the steps highlighted in grey within strict development. Textbooks on innovation processes such as ROOZENBURG & EEKELS or ULRICH & EPPINGER⁵⁷, however, also cover the alignment of multiple projects and products as well as the realization of the product through production, distribution/sale, and use. Besides, production development and marketing planning are covered within innovation processes⁵⁸.

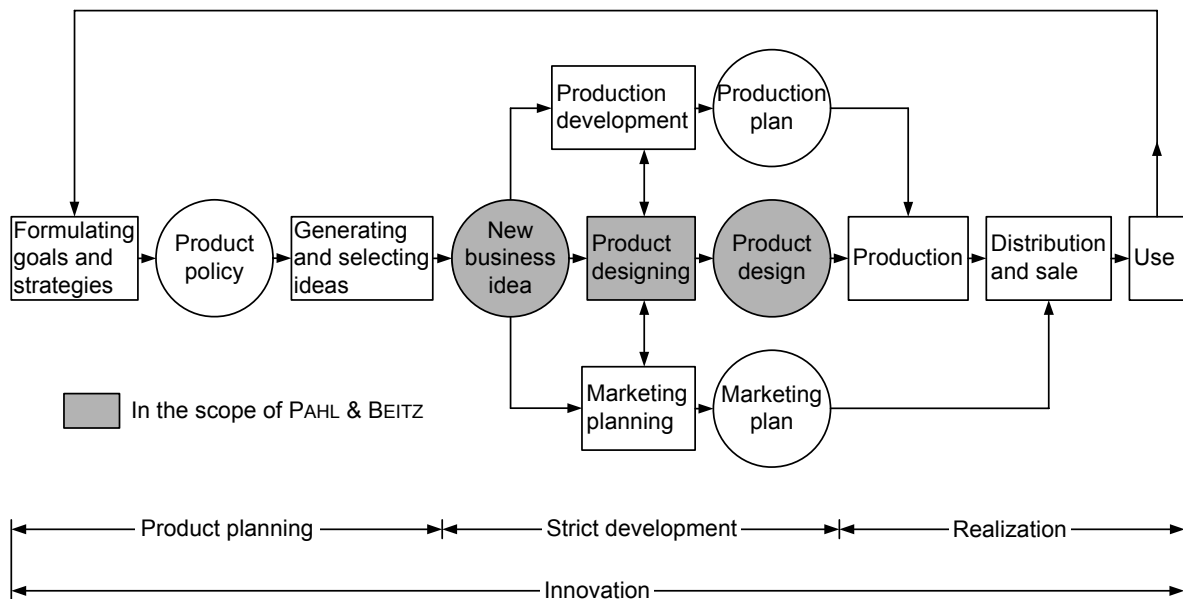

Figure 2-5: Innovation process, based on ROOZENBURG & EEKELS⁵⁹

2.1.3 Outcomes of Innovation

In terms of outcome, one can distinguish between two fundamental types of innovation, i.e. architectural and modular innovation⁶⁰. The outcome of architectural innovation is a strategy of how to put together a product or product family from its components. Typical examples of architectural innovation are product platforms and product families. Modular innovation comprises new modules or end products based on the previously defined strategy. Minor modifications to the product structure may be made, e.g. introduction of new modules or module variants. Typical examples of modular innovation are therefore derivative end products or modules based on an existing product platform or family. It is essential in this context to

57. [Ulrich and Eppinger, 2003], p. 14.

58. See [Bircher, 2005], pp. 23-26 for an extensive differentiation of innovation from engineering design processes.

59. [Roozenburg and Eekels, 1995], p. 13.

60. [Henderson and Clark, 1990], pp. 12-13, [Chen and Liu, 2005], p. 771.

distinguish between these two types of innovation⁶¹. The resources required for modular innovation are generally much smaller than for architectural innovation. That is why product platforms and families mostly have a lifetime of more than five years, while derivative products are developed much more frequently using modular innovation.

The resulting products are subject to a lifecycle⁶² as shown in Figure 2-6. It has been shown by superimposing the lifecycles of individual modules that this lifecycle also applies to product structuring strategies, e.g. a modular product family⁶³.

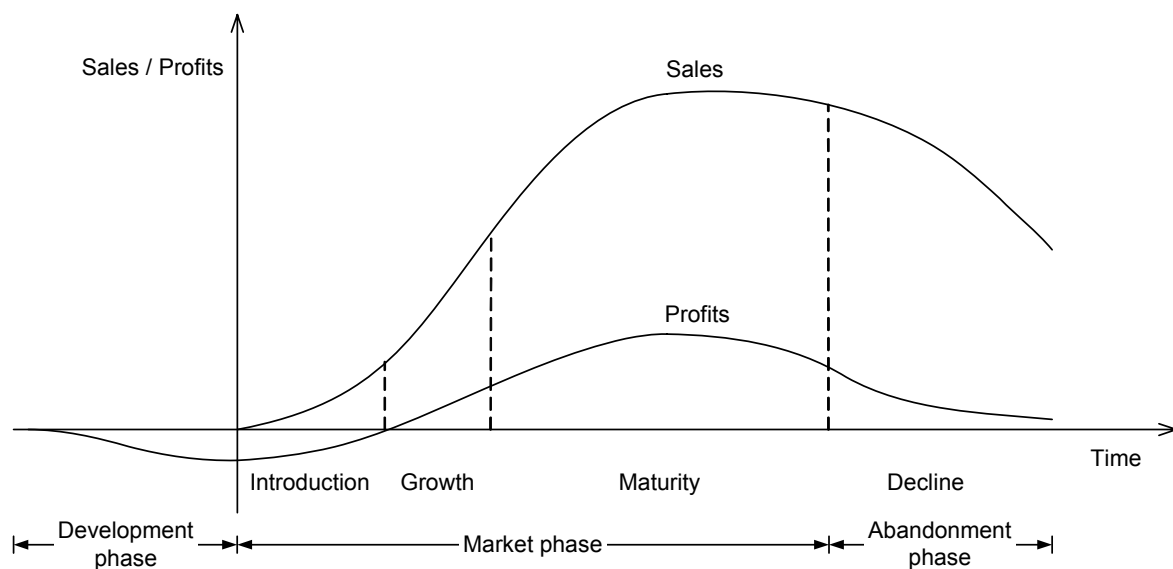

Figure 2-6: Product lifecycle, based on KOTLER⁶⁴ and HEINA⁶⁵

In the *development phase* of the product, costs accrue. Once the product is launched onto the market, it enters the *market phase*, where it passes through the stages indicated in Figure 2-6. In the introduction stage, sales grow slowly and there are still losses due to heavy expenses incurred with product introduction. The break-even point represents the transition to profitability and the start of the growth stage. In the maturity stage, sales growth slows down and profits start to decline due to increased competition. In the *abandonment phase*, both sales and profits erode.

61. [Tatikonda, 1999], p. 16.

62. [Afuah, 2003], p. 126, [Kotler, 2003], pp. 328-343, [Rainey, 2004], p. 82.

63. [Uzumeri and Sanderson, 1995], pp. 585, 586.

64. [Kotler, 2003], p. 128.

65. [Heina, 1999], p. 42.

Different types of product, price, distribution, advertising, and sales promotion strategies are suitable within the different stages⁶⁶. In the growth and maturity stages, for instance, one should offer more variants, while in the decline stage, one should progressively phase out variants and thus slowly take the product from the market.

2.1.4 Positioning with Respect to Innovation

Now, that the objectives, process, and outcomes of innovation have been introduced, variant management of modular product families in the market phase can be positioned with respect to these.

- *Objective*: In Subsection 2.1.1, it was stated that the objectives of innovation are characterized by outcome, timing, and effort. The objectives are specified and attained in normative, strategic, and operative management. In the context of this work, it is assumed that the product strategy, i.e. the decision on the market, market segments, and market niches the company operates in, is given. The task consists of translating this strategy into concrete actions with respect to new modules and module variants. That is why variant management of modular product families in the market phase is positioned on the level of operative management. The new modules and module variants should fulfill objectives in terms of outcome, timing, and effort.
- *Process*: Innovation has been characterized in Subsection 2.1.2 as a process consisting of product planning, strict development, and realization. In variant management of modular product families in the market phase, one faces decisions of whether and how to develop a new module or module variant. That is why it is positioned in the step of generating and selecting ideas within product planning. The downstream processes of strict development and realization, however, need to be considered in making that decision.
- *Outcome*: In Subsection 2.1.3, it was distinguished between architectural and modular innovation in terms of outcome of the innovation process. Both the product structuring strategy, which is the result of architectural innovation, and the single products are subject to a lifecycle. In variant management of modular product

66. [Kotler, 2003], p. 340.

families in the market phase, an existing modular product family is adapted. Consequently, it is positioned in modular innovation of a modular product family that is in its market phase.

2.2 Variant Management

The levels and approaches of variant management are introduced now. Once again, variant management of modular product families in the market phase is positioned with respect to these. It has been described in Section 1.1 that the management of complexity is a key success factor for a corporation. The underlying assumption of variant management is that this can be achieved by focusing on decisions regarding variety in the product portfolio. This is based on the observation that increases in variety through product differentiation initially lead to strong increases in benefit for the corporation. This is because the additional variants provide unique value to the customer⁶⁷. This value can be used to either increase the sales price or open up new market segments. The marginal benefit, however, decreases with increasing variety⁶⁸. At the same time, empirical studies have shown that the costs required to provide variety, the so-called complexity costs⁶⁹, grow exponentially with increasing variety⁷⁰. This phenomenon is the foundation of variant management. It results in two⁷¹ basic tasks within variant management, which are illustrated in Figure 2-7.

1. *Determine appropriate level of variety*: The objective within this task is to determine the level of variety of the product portfolio that maximizes the corporate benefit⁷². All potential measures for mastering variety are assumed to be given. The level of variety is the only decision variable at this stage.

67. [Rathnow, 1993], p. 13.

68. This is because the marginal value of differentiation decreases with increasing variety and potential new market segments are less and less attractive, see [Rathnow, 1993], p. 19.

69. For an extensive definition of complexity costs see [Rathnow, 1993], pp. 8, 9.

70. [Stalk and Hout, 1990], p. 48, [Rathnow, 1993], p. 36.

71. [Matern, 2000], pp. 94-100 also distinguishes between the mastering of variety through structural and through procedural measures. This view is not adopted here because corporate structure and processes are generally inextricably linked. In fact, it is much more important to clearly point out the difference between determining and mastering variety.

72. [Rathnow, 1993], pp. 43-101 describes theoretically how to quantify benefit as a function of variety. This allows the decision maker to determine the appropriate level of variety.

2. *Master variety*: Within this task, the level of variety in the product portfolio is assumed to be given. The given variety is mastered by taking decisions on vertical integration, product design, allocation of material and human resources, and organization⁷³.

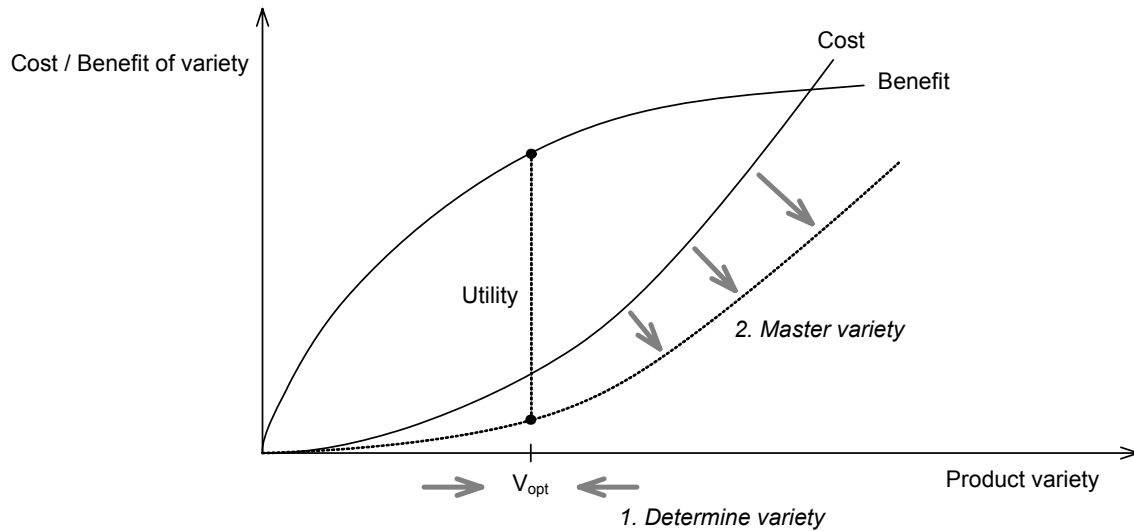

Figure 2-7: Cost-benefit function in variant management, based on RATHNOW⁷⁴

Determination and management of variety are interdependent. That is why it may be necessary to add a third step in which the trade-offs between determining and mastering variety are considered⁷⁵. In the following three subsections, the different levels of variant management and the approaches that exist within variant management are outlined. Variant management of modular product families in the market phase is positioned with respect to these levels and approaches.

2.2.1 Levels of Variant Management

Based on the time horizon of decisions, one may distinguish between strategic and operative variant management. The two levels of variant management roughly map to strategic and operative management in general as described in Subsection 2.1.1. In strategic management, a strategic agenda is determined that includes the competitive strategy and a corresponding product strategy⁷⁶.

73. [Rathnow, 1993], pp. 106-108.

74. [Rathnow, 1993], p. 44.

75. [Rathnow, 1993], p. 167 calls this overall optimization.

The task in *strategic variant management* therefore consists of determining and mastering the variety of the product portfolio in such a way that it is aligned with the competitive and the product strategy⁷⁷. The result of this alignment is called variant strategy⁷⁸. The variant strategy is of long-term character and determines variety for the time horizon of multiple successive product families. Typical examples of decisions to be taken in strategic variant management are whether the company is offering a broad or a narrow product portfolio as well as customized or standardized solutions⁷⁹.

The task in *operative variant management* consists of implementing and securing the variant strategy⁸⁰. Decisions in operative variant management generally have medium-term impacts and do not span the lifecycles of several products or product families. Operative variant management rather is a continuous process to control the product portfolio⁸¹. Changing external influences such as altering customer demands and emerging technologies force the corporation to realign the product portfolio with the variant strategy⁸². Concretely, this implies that weak products are eliminated from the portfolio, while promising products are included.

2.2.2 Approaches of Variant Management

The operative and strategic steps that are taken in the scope of variant management can be classified into four generic types of approaches⁸³.

- *Variant generation*: If more utility can be created by providing more variety to the customer in order to increase sales prices or open up new markets, additional variants may be introduced into the product portfolio. In doing so, one should strive to minimize the resulting complexity costs.

76. [Kaiser, 1995], p. 112.

77. [Heina, 1999], p. 40.

78. [Rathnow, 1993], p. 179.

79. [Sekolec, 2005], p. 28.

80. [Rathnow, 1993], pp. 179, 180.

81. [Heina, 1999], p. 41.

82. [Rathnow, 1993], p. 180.

83. [Heina, 1999], pp. 41-43, [Sekolec, 2005], pp. 29, 30.

- *Variant prevention*: The steps which are part of variant prevention include suitable product concepts and designs so as to prevent unprofitable variants. Variant prevention also includes the deliberate analysis of potential new variants to prevent unprofitable variants from entering the product portfolio.
- *Variant reduction*: In variant reduction, existing variants are eliminated from the product portfolio with the intent of minimizing complexity costs.
- *Variant handling*: This includes all measures that are taken to better handle the existing level of variety, e.g. the introduction of a configurator to carry out order processing more efficiently.

As described in Subsection 2.1.3, products and product families are subject to a lifecycle. The feasibility of the three approaches changes as a function of the lifecycle⁸⁴. This is shown in Figure 2-8.

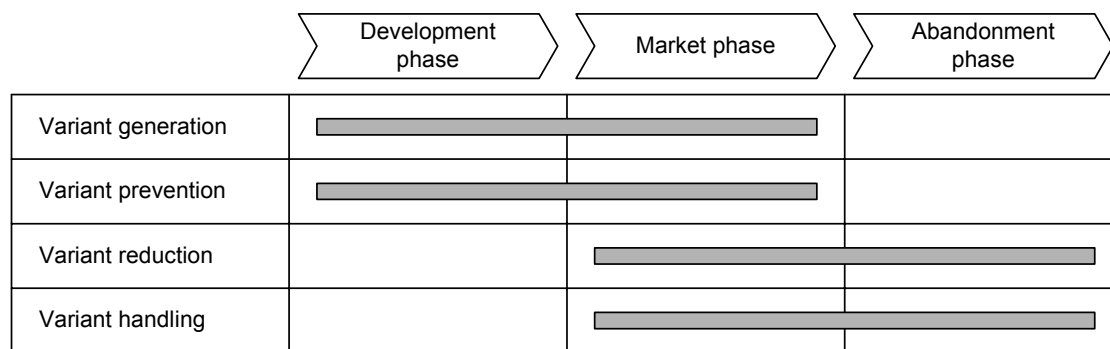

Figure 2-8: Approaches of variant management in the product lifecycle, based HEINA⁸⁵

In the development phase, necessary variants are scheduled based on sales planning. The focus is on variant generation and prevention. In the market phase, additional variants are created to cope with new technologies and functional requirements. At the same time, unprofitable variants are eliminated from the product portfolio and steps are taken to better handle the existing variety. The market phase therefore includes all four approaches of variant management. In the abandonment phase, the primary objective is to reduce the number of variants and better handle the remaining ones.

84. [Heina, 1999], pp. 42, 43.

85. [Heina, 1999], p. 42.

2.2.3 Positioning with Respect to Variant Management

The tasks, levels, and approaches of variant management have been described. Variant management of modular product families in the market phase is now positioned with respect to variant management.

- *Level*: The strategic and operative level of management have been defined in Subsection 2.2.3. On the strategic level, the variant strategy determining the product portfolio to be offered in the long term is specified. Operative variant management is about implementing and securing the variant strategy. In operative variant management, changing customer demands and technologies are taken care of by eliminating products from the portfolio and adding new ones. In variant management of modular product families in the market phase, one deals with an already existing product family. This product family is the result of a previously specified variant strategy. The tasks consists of aligning the existing product family with the variant strategy under the influence of changing markets and technologies. Objectives in the scope of the variant strategy can be described by the triangle of objectives. Consequently, variant management of modular product families in the market phase is part of operative variant management.
- *Approach*: All four approaches, i.e. variant generation, prevention, reduction, and handling are applied in the market phase of a modular product family. That is why all four are part of variant management of modular product families the market phase.

2.3 Product Structuring

The approaches, types, and phases of product structuring are introduced in this section. The product structure⁸⁶ is defined as the composition of a product from its building blocks. These building blocks may be assemblies, single parts, or part sets⁸⁷. It belongs to the product documentation that is created in the innovation process described in Subsection 2.1.2. The product structure is generally represented using a bill of material (BOM) or block diagram. An

86. In the American literature, the term product structure is often used interchangeably with product architecture. Here, product architecture refers to something else, namely the mapping from the functional to the physical domain.

87. [Sekolec, 2005], p. 19, [Schuh, 2005], p. 73, [Rapp, 1999], p. 9.

example of a product structure is given in Figure 2-9. There may be several product structures for the same product, e.g. for development, assembly, and service.

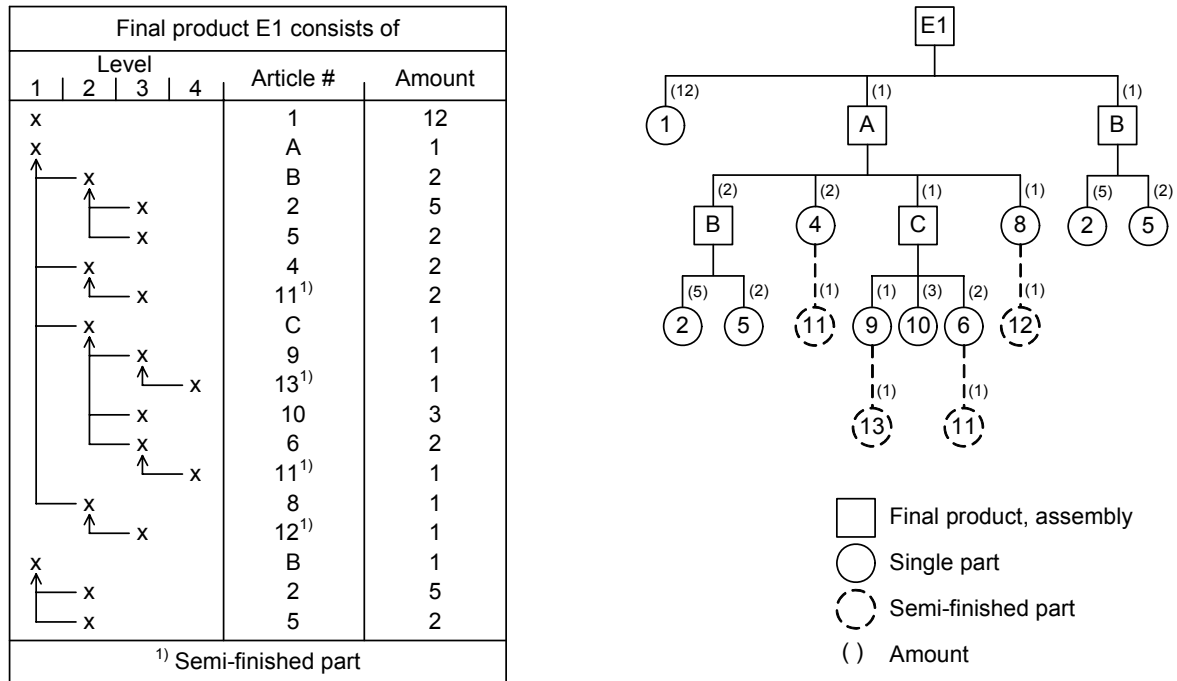

Figure 2-9: Product structure, based on DIN 199-1⁸⁸

In a traditional engineering design process⁸⁹, the product structure is not consciously controlled. It is a by-product of engineering design. Using product structuring, however, the product structure is determined in a deliberate process. Examples of perceived benefits of product structuring are economies of scale, more product variety, shorter order leadtime, decoupling of tasks⁹⁰, and above all, the reduction of the impact of different customer demands.

2.3.1 Approaches of Product Structuring

The approaches of product structuring deal with consciously generating, analyzing, or modifying the product structure. The product structure as shown in Figure 2-9 is therefore the central field of activity of product structuring. The three approaches of product structuring to operationalize the concept of variant management⁹¹ are described in the following.

88. [DIN199-1, 2002], p. 9.

89. See for instance the process in [Pahl and Beitz, 1996] described in Subsection 2.1.2.

90. [Ulrich and Tung, 1991], p. 75.

91. [Sekolec, 2005], pp. 34, 35.

- *Product design*: In this approach, it is defined which variety is to be offered to the customer and through which variety of assemblies and parts this is to be realized. Both market demands and downstream processes have to be considered. In product design, the product structure of a single product or product family is thus created in a deliberate rather than in a random process.
- *Product analysis*: The objective using this approach is to create transparency in the product family. That is why the product structure of the existing product family is analyzed and depicted in a structured manner as in Figure 2-9. This is necessary if the product structure has not been created and recorded in a deliberate process as described above. As a result, the necessary conditions are created for formulating and implementing efficient processes and information systems adapted to the existing product structure.
- *Product family simplification*: This approach very often follows product analysis. Potential simplifications are identified using a clear representation of the product structure. Comparing this representation on the one hand to actual customer needs on the other generally reveals redundant or unprofitable variants. These variants may be eliminated to simplify the product family.

2.3.2 Types of Product Structures

As outlined above, product structuring results in a deliberately determined product structure. Four types of product structures can be distinguished⁹². These are described in the following and summarized in Figure 2-10.

92. [Schuh, 1989], p. 58, [Schuh, 2005], p. 81.

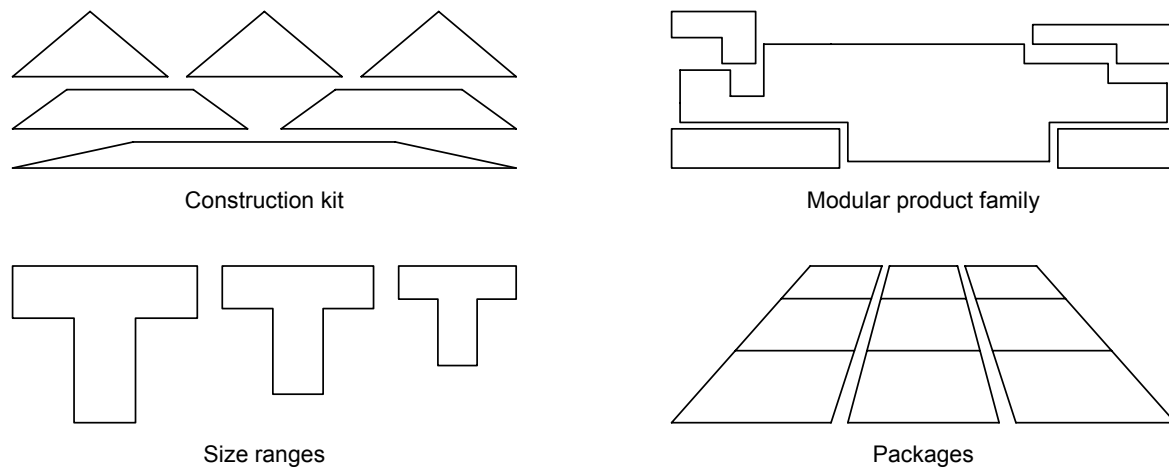

Figure 2-10: Types of product structures, based on SCHUH⁹³

Construction Kit

A construction kit is a system of products, assemblies, and parts that serve as building blocks. These building blocks can be combined in different ways so as to realize different overall functions⁹⁴. Construction kits can be further classified into manufacturer's and user's construction kits based on whether the manufacturer or the end user assembles the product variant⁹⁵. Moreover, there are open and closed construction kits depending on whether the number of theoretically possible product variants is finite or infinite⁹⁶. Finally, there are structurally bounded and free construction kits based on whether the building blocks have a fixed location in the product or can be fixed in multiple locations.⁹⁷

A construction kit generally has one or several base assemblies that the building blocks are attached to. Construction kits and modular product families only differ in terms of interfaces. A construction kit has its interfaces primarily between each single building block and the base assembly. In a modular product family, however, a module may have interfaces with more than one other module⁹⁸. Some authors do not make a difference between construction kits and modular product families⁹⁹. WÜPPING¹⁰⁰ concludes that construction kits and modular product

93. [Schuh, 1989], p. 58.

94. [Rapp, 1999], p. 52, [Schuh, 2005], p. 58, [Sekolec, 2005], p. 59.

95. [Ehrlenspiel, 1995], pp. 629, 630.

96. [Ehrlenspiel, 1995], pp. 630.

97. [Koller, 1998], pp. 338-340.

98. [Rapp, 1999], p. 53.

families imply the same thing. Here, no difference is made between construction kits and modular product families.

Modular Product Family

The literature regarding the definition of modularity is enormous¹⁰¹ and no single generally accepted definition of modularity exists today. The two commonalities among all definitions are illustrated in Figure 2-11.

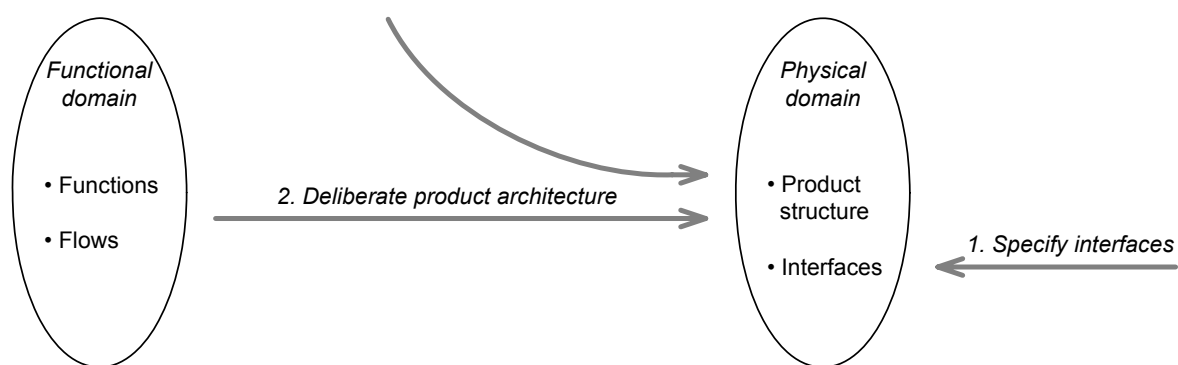

Figure 2-11: Definition of modular product family

First, modular product families have specified interfaces between modules and there are generally fewer interactions between than within modules¹⁰². ULRICH¹⁰³ further distinguishes between slot, bus, and sectional modularity depending on whether interfaces between modules are unique, all connect to a single bus module, or are standardized across all modules. Second, modular product families have a deliberate product architecture¹⁰⁴. Product architecture is the way in which the mappings are carried out from the functional to the physical domain¹⁰⁵. This is based on the theory of domains according to which design is a subsequent mapping to more and more concrete entities¹⁰⁶. The functional domain, for instance, contains the functions and flows of the product. The physical domain contains the parts and assemblies, i.e. product

99. See for instance [Kähler et al., 1983], pp. 114-116.

100. [Wüpping, 1992], p. 13.

101. [Gershenson et al., 2003], pp. 295-303.

102. [Ulrich, 1995], pp. 423, 424, [Baldwin and Clark, 1997], p. 86, [Allen and Carlson-Skalak, 1998], p. 6.

103. [Ulrich, 1995], pp. 424-426.

104. [Göpfert, 1998], p. 107 describes these properties of a modular product family as the functional and the physical independence.

105. [Ulrich and Eppinger, 2003], p. 165.

106. The theory of domains is the underlying theory in [Andreasen, 1992] and [Suh, 1990].

structure, as well as the interfaces to fulfill these functions. Product architecture describes the rationale applied in mapping from the functional to the physical domain.

The specific methods for conceiving modular product families imply more detailed definitions than the generic one shown in Figure 2-11. Three of the most prominent methods for product structuring are described in the following¹⁰⁷. This is the basis for determining the key properties of modular product families in Subsection 3.1.1.

ULRICH & TUNG¹⁰⁸ provide guidelines for conceiving modular product families by stating that a modular product should have two characteristics: (i) ‘Similarity between the physical and functional architecture of the design’ and (ii) ‘minimization of incidental interactions between physical components.’ These guidelines therefore include both of the aspects of the definition shown in Figure 2-11. First, interactions among modules should be minimized. Second, the product architecture should be such that there is a one-to-one correspondence between functions and physical components. ULRICH & EPPINGER¹⁰⁹ further develop these guidelines into a method to conceive a modular product family. In the first step, a function structure of the product or product family is conceived. The second step is to cluster the function structure and identify chunks based on eight criteria. In the next step, a rough geometric layout is created to position the major chunks. Finally, interactions between the chunks are identified. If the resulting chunks exhibit the above-described characteristics of similarity between physical and functional architecture and minimization of interaction, they are called modules.

ERIXON¹¹⁰ provides a method called modular function deployment (MFD) to define the modules within a product family based on the specific needs of the company. Technical solutions are developed for each of the functions. The technical solutions are assessed against module drivers, which are indicators of whether a specific function carrier should become a module. The module drivers originate from the areas of development and design, variance, manufacturing, quality, purchasing, and after sales. Function carriers that score high on the module drivers are pointed out as promising candidates for modules. The remaining function carriers are assigned to these modules. Finally, the interfaces among the resulting modules are

107. For an extensive review of methods and definitions for modular product families, see [Gershenson et al., 2003].

108. [Ulrich and Tung, 1991], p. 73.

109. [Ulrich and Eppinger, 2003], pp. 171-177.

110. [Erixon, 1998], pp. 65-106.

specified. MFD also incorporates both aspects of the definition depicted in Figure 2-11. Unlike the guidelines by ULRICH & TUNG, MFD also brings in aspects from outside the functional domain into the specification of product architecture, e.g. manufacturing or quality.

OTTO & WOOD¹¹¹ provide a heuristic method for module identification that is a simple way of defining modules based on energy, material, and signal flows in the functional domain. Three heuristics are used. First, according to the dominant flow heuristic, functions connected by a non-branching flow should become a module. This is shown in the top left of Figure 2-12. Second, parallel function chains are identified using the branching flow heuristic. Each limb of the chain in Figure 2-12 then becomes a module. Finally, following the conversion heuristic, conversion functions and associated transmission functions become modules. The heuristic method also incorporates both aspects of the definition of a modular product family. First, interactions among modules are minimized by considering the flows among functions and applying the heuristics. Second, product architecture is specified by the deliberate process of applying the three heuristics.

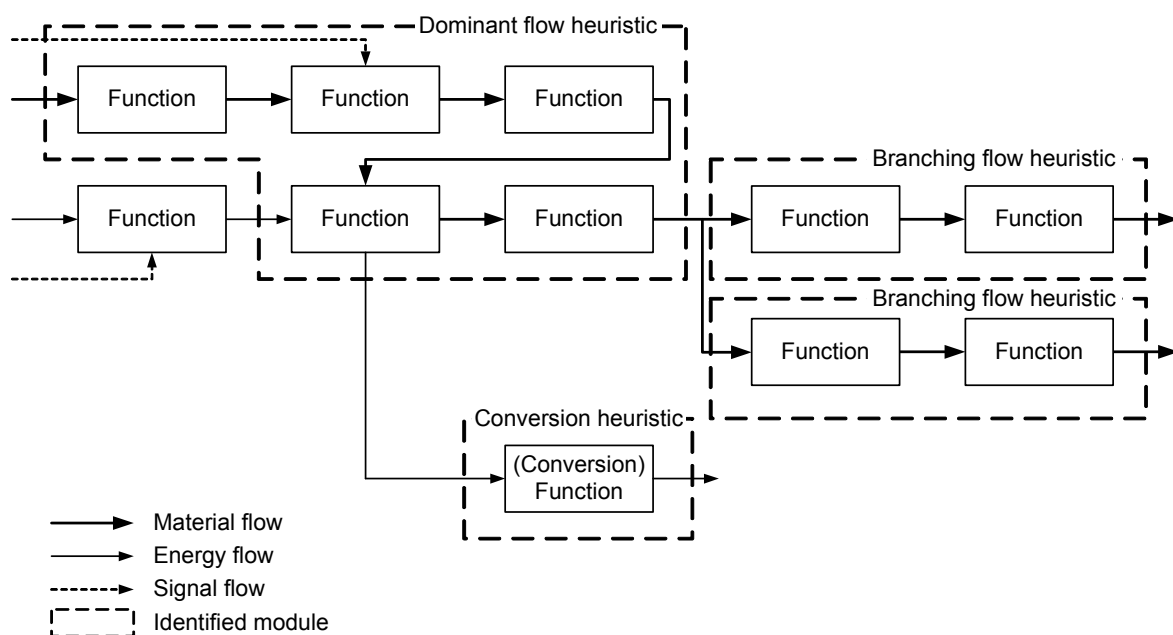

Figure 2-12: Heuristics for module identification, based on OTTO & WOOD¹¹²

111. [Otto and Wood, 2001], pp. 378-395.

112. [Otto and Wood, 2001], pp. 381, 385, 388.

A *product platform* is a special type of modular product family¹¹³. In a product platform, the emphasis is one or several modules which are standardized and applied across all members of the product family¹¹⁴. Product platforms are known primarily from the automotive industry, where the chassis is standardized and applied across multiple products¹¹⁵. They have, however, also been applied in numerous other industries¹¹⁶.

Size Range

A size range is a line of products, assemblies, or parts whose members fulfill the same function and are based on the same solution principle. They are made in varying sizes but involve similar manufacturing processes¹¹⁷. As a result, there is only one major development effort. Additional products, assemblies, or parts within the size range can be rapidly derived with the help of similarity laws¹¹⁸. Size ranges facilitate cutting down cost in manufacturing. Variety is reduced to a few size variants, which can be manufactured in batches. Moreover, lead times can be reduced in development and quality can be improved¹¹⁹.

Packages

Packages are made up of additional assemblies or parts to a basic product that may only be chosen together. Packages are used amongst others in the automotive industry to limit the number of possible configurations and thus reduce effort in manufacturing and logistics¹²⁰.

2.3.3 Phases of Product Structuring

Product structuring is an important activity in innovation. As shown in Subsection 2.1.3, one may distinguish between architectural and modular innovation in terms of the outcome of innovation. The strategy to structure a modular product family is the outcome of architectural

113. [Muffatto, 1999], p. 146, [Simpson, 2003], pp. 2, 3, [Junge, 2005], p. 21.

114. [Robertson and Ulrich, 1998], p. 20, [Piller, 2001], p. 229, [Muffatto and Roveda, 2002], p. 4, [Sekolec, 2005], p. 64.

115. [Wilhelm, 1997] p. 146, [Kimberly, 1999], pp. 62-64.

116. [Simpson, 2003], pp. 2, 3.

117. [Ehrlenspiel, 1995], p. 617, [Pahl and Beitz, 1996], p. 405, [Koller, 1998], p. 327.

118. [Pahl and Beitz, 1996], pp. 406-409.

119. [Ehrlenspiel, 1995], pp. 617, 618.

120. [Schuh, 1989], p. 59.

innovation, while the individual modules are the result of modular innovation. It has been observed that architectural and modular innovation impose different tasks on product structuring and result in different types of innovation processes¹²¹. Based on these findings, one can differentiate between the two types of phases of product structuring depicted in Figure 2-13.

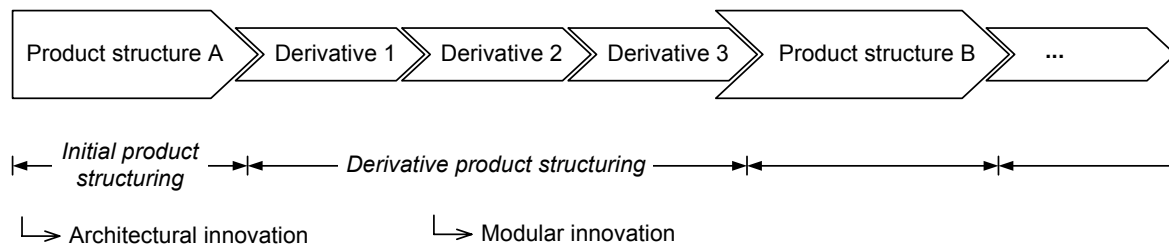

Figure 2-13: Initial and derivative product structuring

- *Initial product structuring*: This is the phase in which one actively develops the basic product structure of a product family by introducing construction kits, modular product families, size ranges, and packages. This basic product structure specifies the principal components and variants of the product family and their interfaces. Initial product structuring is carried out in the scope of an innovation process and belongs to architectural innovation. The resulting product structure and interfaces are generally quite durable¹²² as they represent the realization of the variant strategy described in Subsection 2.2.1.
- *Derivative product structuring*: Within this phase, derivatives are developed. Depending on the type of product structuring strategy chosen, the derivatives can be modules, module variants, or entire products. The derivatives are based on the basic product structure conceived in initial product structuring. The innovation processes within derivative product structuring belong to modular innovation. The objective does therefore not consist of setting up a new basic product structure, but to maintain and add to an existing one.

121. [Meyer and Lehnerd, 1997], pp. 40-42, [Müller, 2000], pp. 31, 32.

122. [Preiss et al., 2006], p. 5 observe in interviews with industrial representatives that in more than the three quarters of the companies product structuring concepts last for seven years or more.

2.3.4 Positioning with Respect to Product Structuring

The approaches and phases of product structuring as well the resulting types of product structures have been described. In the following, variant management of modular product families in the market phase is positioned with respect to these.

- *Approach*: Three types of approaches have been identified within product structuring, namely product design, product analysis, and product family simplification. Variant management of modular product families in the market phase is about making decisions on whether or not to generate variety through additional modules and module variants and designing these in a way such as to maximize utility. This requires a clear understanding of what the modular product family is. It may also include the simplification of an existing modular product family. Variant management of modular product families in the market phase therefore includes the approaches of product analysis, product design, and product family simplification.
- *Type*: Four types of product structures have been identified, namely construction kits, modular product families, size ranges, and packages. Modular product families are obviously relevant in variant management of modular product families. Since a construction kit basically implies the same as a modular product family, construction kits are also included. Product platforms are included as a special case of modular product family. On the top level, a modular product family consists of modules and module variants that are configured to the customer order. Modules and module variants can be decomposed into lower level components such as assemblies or parts.
- *Phase*: In initial product structuring, a new basic product structure is developed for a product family. In derivative product structuring, this product structure is maintained and updated by developing derivatives. In variant management of modular product families, one deals with an existing basic product structure. It therefore belongs to derivative product structuring.

2.4 Overall Positioning and Definition

In the previous three sections, variant management of modular product families has been positioned within design science. Three relevant fields have been identified, namely innovation, variant management, and product structuring. These fields have been further broken down into key concepts based on criteria such as objectives or approaches. The key concepts that are

relevant for variant management of modular product families in the market phase have been identified. This is summarized in Figure 2-14.

Design science	Innovation	Objective	Normative		Strategic		Operative
		Process	Product planning		Strict development		Realization
		Outcome	Architectural			Modular	
	Variant management	Level	Strategic			Operative	
		Approach	Variant generation	Variant prevention	Variant reduction	Variant handling	
	Product structuring	Approach	Product design		Product analysis		Product family simplification
		Type	Construction kit	Modular product family	Size range	Packages	
		Phase	Initial product structuring			Derivative product structuring	

Figure 2-14: Positioning

Based on this positioning within design science, a definition of variant management of modular product families in the market phase can now be provided.

‘Variant management of modular product families in the market phase’ is the decision about generating profitable new modules and module variants for an existing modular product family and about preventing unprofitable modules and module variants. The decision is to be based on outcome, effort, as well as timing and should be in line with the variant strategy. The decision is made in product planning when one selects and improves concepts. It also includes all decisions taken to reduce the number of modules and module variants for an existing modular product family and to better handle variety.

Although variant reduction and variant handling from variant management and product family simplification from product structuring are formally part of variant management of modular product families in the market phase, they are not considered in the following. There are three reasons for this. First, the increasing number of variants in the market phase was identified as an exigent challenge in Subsection 1.2.1. In this context, it is more expensive to handle and reduce variants than to prevent and effectively generate them in the first place. While variant handling and reduction as well as product family simplification may still be necessary as a result of unpredictable events, variant prevention and generation potentially have the better cost-benefit ratio. Second, methods are provided in the literature to carry out variant reduction and

product family simplification¹²³. Third, variant handling is an extremely broad topic that probably cannot be answered with a single, focused method. It includes anything from the introduction of software systems, e.g. PLM systems or configurators, to the reengineering of processes and organization. These different steps are extensively covered in dedicated publications.

Consequently, requirements, related work, and the proposed variant management funnel in the following all address variant management of modular product families from the points of view of variant generation/prevention and product design/analysis.

123. [Hichert, 1985], p. 237, [Kunz, 2005], pp. 167-169, [Wiendahl, 2004], pp. 46-48, [Schuh and Tanner, 1998], pp. 3-5.

Chapter 3

Requirements and Related Work

In the previous chapter, variant management of modular product families in the market phase has been defined. In Section 3.1 of this chapter, the requirements for a method to support variant management of modular product families in the market phase are elaborated. There are two fundamental functional requirements for the method. First, it should help safeguard the modular product family's key properties. Second, it should allow the decision maker to select and improve concepts for potential new modules and module variants according to specific decision criteria. The requirements are summarized in a requirements list. Existing methods from the literature are assessed against the requirements list in Section 3.2. The discrepancy between the requirements list and existing methods is the research gap which has to be closed with this work. The research gap is described in Section 3.3. In Section 3.4, the research gap is summarized in the research question.

3.1 Requirements

The method has to support variant management of modular product families in the market phase. Concretely, this implies that it should support decisions about generating new modules and module variants. The cumulative committed and expended costs of a product over its life-cycle are shown in Figure 3-1. It can be seen that costs are roughly committed along a logarithmic curve. Hence, the ability to influence the success of a new module or module variant is very large at the concept stage but rapidly decreases thereafter. That is why a method for variant management of modular product families is most effective if it helps evaluate new modules and module variants during the concept stage.

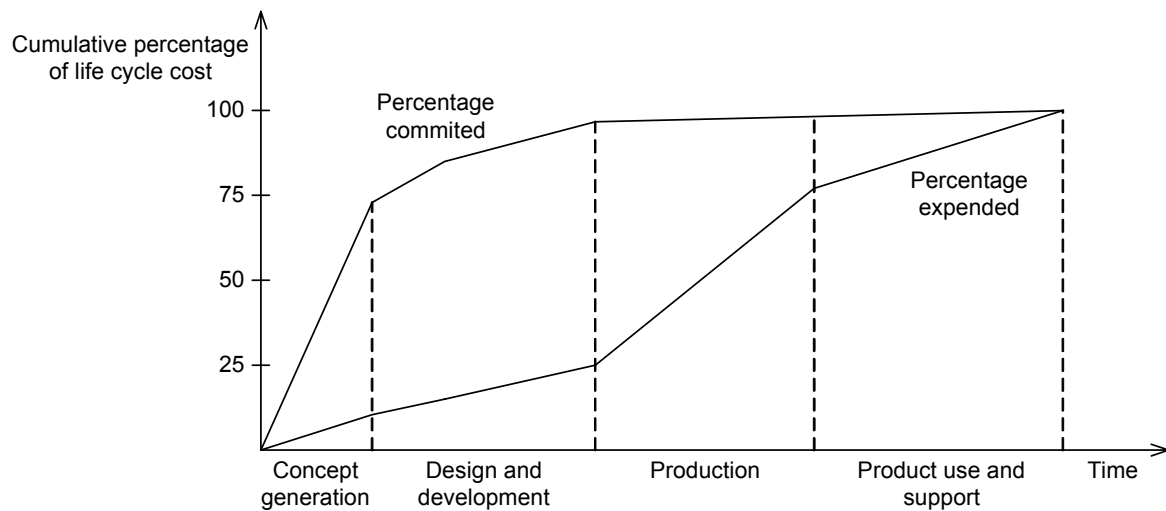

Figure 3-1: Cumulative product lifecycle cost, according to MAGRAB¹²⁴

During concept evaluation, the most important aspect to consider is whether the proposed module or module variant alters the key properties of the modular product family that have been determined in initial product structuring. In Subsection 3.1.1, it is therefore discussed what these key properties are. The resulting requirements for the method to safeguard these properties are described.

The second aspect to consider in decision making is the contribution that the proposed new module or module variant makes to the variant strategy. This is to be measured by decision criteria, which should be evaluated for all stakeholders involved in the company. Using these decision criteria, different concepts for new modules and module variants can be evaluated and the most appropriate one can be selected. The selected concept then has to be improved with respect to the decision criteria. All this must also be supported by the method and is discussed in Subsection 3.1.2.

3.1.1 Safeguard Key Properties

Safeguarding the modular product family's key properties is the primary function of any method to support variant management of modular product families in the market phase. Based on the definition of a modular product families shown up in Subsection 2.3.2, it can be concluded that a modular product family has the following key properties.

124. [Magrab, 1997], p. 30.

- *Product structure*: In initial product structuring, a product structure is deliberately determined based on a mapping from the functional domain to the physical domain plus additional considerations. The product structure is therefore the first key property of a modular product family.
- *Interfaces*: There should be comparatively few and controlled interactions between the different modules. The different methods for conceiving modular product families differ in terms of the exact procedure applied to minimize interactions¹²⁵. It is, however, common to all methods that interactions are effectively determined by the modules' interfaces. The second key property of a modular product family are therefore the interfaces between its modules.

These two key properties are to be safeguarded and result in the requirements described in the following.

1. *Safeguarding of product structure*: The use of the method must enforce safeguarding of the product structure of the modular product family down to the level of modules or module variants. It is generally not necessary in this context to safeguard the product structure below this level, i.e. the assemblies and parts within a module. These are generally not characteristic of a modular product family and may be changed through modular innovation. A modular product family also incorporates variety in the form of module variants. This must be kept in mind.
2. *Safeguarding of interfaces*: The use of the method must enforce safeguarding of interfaces between modules and module variants. That is why the method must allow the user to capture all information required to check whether a concept violates the modular product family's interfaces. Not only may this include the physical interfaces themselves but also additional information that might be required to safeguard them, such as configuration rules or a usage list. All types of interfaces generally encountered in mechatronic products today are to be considered.
3. *Require few resources*: The method is to be used in an industrial context for rapidly checking whether a proposed concept conserves the key properties and reworking a concept when necessary. The method should therefore be simple to understand and

125. [Erixon, 1998], pp. 83-85 minimizes interaction by describing interfaces in a matrix and evaluating the interactions. [Otto and Wood, 2001], pp. 379-389 minimize interactions through application of three heuristics. [Ulrich and Eppinger, 2003], pp. 173-175 minimize interactions as part of their eight criteria for defining chunks.

require no extensive previous knowledge nor infrastructure. Since the decision maker may face a significant number of concepts needing to be checked for key properties, the application of the method also needs to be quick. This may be facilitated using computer support.

If the above requirements are fulfilled, the decision maker facing a number of concepts for new modules and module variants can easily identify those concepts that violate the key properties of the modular product family. One may decide to either discard or rework the respective concepts.

3.1.2 Evaluate and Improve Concepts

Once the concepts that violate key properties have been discarded or corrected, the decision maker has to decide on the most feasible concept for a new module or module variant. According to KARANDIKAR & MISTREE¹²⁶, there are two primary types of decisions. First, there is *selection*, when the decision maker makes a choice among several alternatives. This requires the evaluation of the individual concepts. Second, there is *compromise*, when the decision maker considers just one concept and seeks to improve it.

4. *Evaluation of concepts based on variant strategy*: Any objective in innovation can be characterized by the three dimensions of outcome, effort, and timing. The method for variant management of modular product families in the market phase has to allow the decision maker to evaluate concepts based on decision criteria within these three dimensions. The concrete choice of decision criteria depends on the particular variant strategy as well as the company and may therefore not be prescribed by the method. The method thus has to allow for multiple decision criteria. Decisions on new modules and module variants influence stakeholder all along the innovation process. Due to the broad scope of innovation, this can affect many stakeholders in the corporation. This scope must be acknowledged in the method.

126. [Karandikar and Mistree, 1993], p. 252.

5. *Improvement of concepts based on variant strategy*: The application of the method has to provide the decision maker with hints of how the concept for a new module or module variant can be improved in view of the variant strategy. The method must allow the decision maker to easily reevaluate the modified concept. The user can then decide based on the decision criteria whether the modified concept is more suitable.
6. *Be quantitative*: Information can be accurately transmitted and processed using numbers. This is particularly important if one deals with multiple effects across the corporation. Moreover, the decision maker wants to know by how much a concept is better or worse than another concept. That is why the method has to be quantitative.
7. *Incorporation of uncertainty and risk*: The effects of decisions about generating new modules and module variants occur across the entire lifecycle of the modular product family. They thus have an influence on the corporation for several years in the future. Decisions in engineering design in general¹²⁷ and decisions in variant management of modular product families in particular can therefore not legitimately be made without considering uncertainty and risk. Following HAZELRIGG¹²⁸, uncertainty is defined as the inability to predict future events with precision, while risk is the variability of the payoff or outcome of a decision resulting from uncertainty. Both uncertainty and risk need to be acknowledged in the method.
8. *Require few resources*: This requirement was already relevant for safeguarding key properties. It also applies to evaluating and improving concepts. In order to facilitate industrial application, the effort required to evaluate concepts has to be rather small. Ideally, a concept should be evaluated within a couple of minutes. The effort required for initially implementing the method in the company should not be too large either. Since this occurs only once during the lifecycle of the modular product family, more effort is, however, permissible here than in the use of the method.

3.1.3 Requirements List

The method to be elaborated has two primary functions, namely to safeguard key properties and to evaluate and improve concepts. These functions and the corresponding requirements are

127. [Simon, 1996], p. 118, [Hazelrigg, 1998], p. 656, [Martston and Mistree, 1998], p. 3.

128. [Hazelrigg, 1998], p. 653.

summarized in the requirements list shown in Figure 3-2. Note that the requirement on resources occurs twice as it applies to both functions.

Requirements list	
Method to support the variant management of modular product families in the market phase	
Safeguard key properties	
• 1. <i>Product structure:</i>	- Safeguard product structure down to level of modules/module variants - Account for variety in the product family
• 2. <i>Interfaces:</i>	- Safeguard interfaces between modules of the modular product family - Account for all types of interfaces encountered in mechatronic products
• 3. <i>Resources:</i>	- Be simple to understand - Require no previous knowledge nor infrastructure - Rapid application
Evaluate and improve concepts	
• 4. <i>Evaluation:</i>	- Evaluate concepts based on multiple decision criteria - Consider decision criteria in outcome, effort, and timing - Consider all stakeholders affected in company
• 5. <i>Improvement:</i>	- Improve concepts based on multiple decision criteria - Consider decision criteria in outcome, effort, and timing - Easily reevaluate concepts
• 6. <i>Quantitative:</i>	- Information given into and coming out of the method is quantitative
• 7. <i>Uncertainty/risk:</i>	- Consider uncertainty in the decision and incorporate risk into decision basis
• 8. <i>Resources:</i>	- Rapid evaluation of concepts - Reasonable effort for setting up method - Rapid application

Figure 3-2: Requirements list for method to support variant management

The requirements list is used for evaluating related work and opening up the research question in the following sections. Besides, it is used for validating the proposed method for variant management of modular product families in the market phase in Section 6.3.

3.2 Related Work

Related work from the literature that can fulfill some of the requirements specified in the last section is presented here. The methods are evaluated against the requirements. Each time a specific requirement is discussed, its respective number is given in brackets, e.g. (4) for comments relating to the fourth requirement. A summary of how the methods perform is shown in Figure 3-14 at the end of the next section. Methods addressing both the safeguarding of key

properties and the evaluation/improvement of concepts are discussed in Subsection 3.2.1. Methods that address only the safeguarding of key properties or evaluation/improvement are discussed in Subsection 3.2.2 and Subsection 3.2.3, respectively.

3.2.1 Methods for Safeguarding Key Properties and Evaluation/Improvement

Variant Mode and Effects Analysis

The variant mode and effects analysis (VMEA) is a method to structure and control variety in the product portfolio¹²⁹. It consists of four phases.

- *Determine desired functions and cost*: The decision maker determines which functions are demanded by the customer and how much they may cost based on target costing. By comparing target costs to projected actual costs, it is decided which functions demanded by the customer should actually be covered.
- *Determine variants and possible combinations*: Different variants of functions are characterized by parameters and respective values. It is determined how the functions may be combined among each other. The results are summarized in a parameter/value table. Due to costs for interfaces, it is generally not advisable to design the modules in such a way that they can be combined arbitrarily. That is why compatibility rules are set up and laid down in a compatibility matrix. The designer then determines parts and assemblies that are to fulfill the desired functions. The order of assembly is specified in the variant tree such as the one shown in Figure 3-3.
- *Evaluate alternatives*: Alternative solutions for the desired functions are evaluated. This is carried out by quantifying the envisaged effects of different alternatives using activity-based costing.
- *Set up effective marketing*: The marketing process of the product family is set up in such a way that the product can be efficiently and effectively configured.

Although the VMEA was not specifically designed to safeguard a modular product family's key properties, it can be used to capture and maintain the product structure from a manufacturing point of view (1). The variant tree within the VMEA is intuitive, requires no previous knowledge nor infrastructure, and can be rapidly applied (3). The interfaces among modules,

129. [Caesar, 1991], pp. 28-39, [Schuh and Tanner, 1998], pp. 2-6.

however, are not considered at all (2). Moreover, it is only stated within the VMEA that the functionality of the modular product family may be modified. It is not suggested how this might be done. Very little support is therefore provided for evaluating and improving concepts (4, 5). Since activity-based costing is used for evaluating concepts, the VMEA is quantitative (6). Uncertainty and risk are not considered, though (7). The VMEA is a very generic approach and a significant effort will always go into operationalizing the VMEA for a particular task (8).

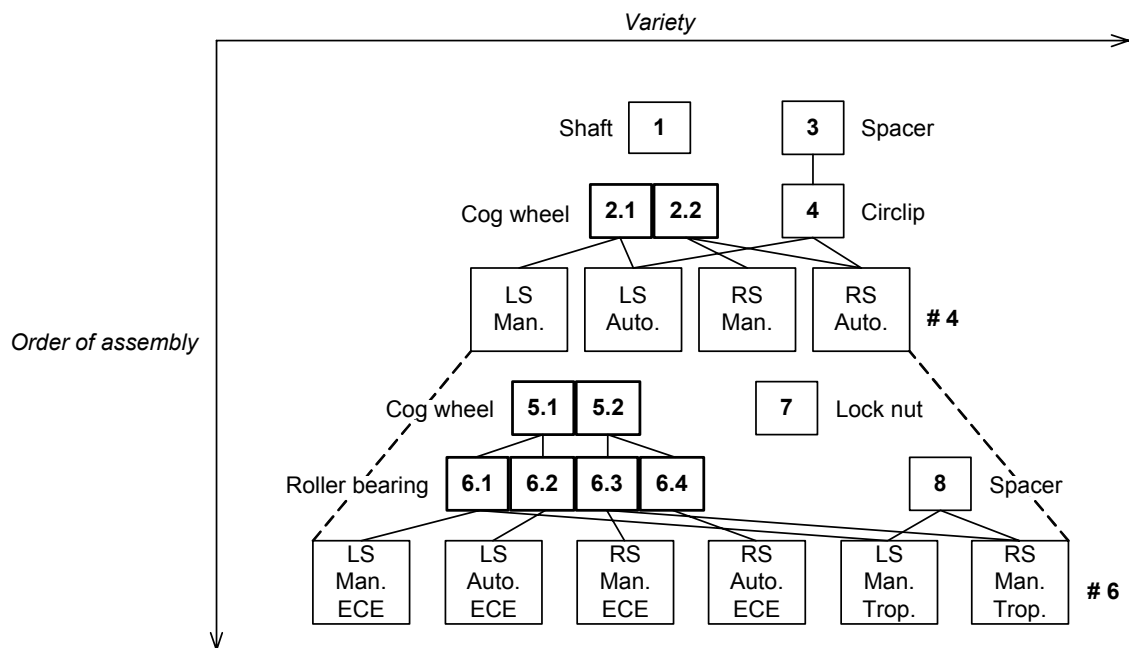

Figure 3-3: Variant tree, based on SCHUH & JONAS¹³⁰

Systemic Variant Management

Systemic variant management according to MATERN¹³¹ is a framework for operationalizing and quantifying variant management as defined by RATHNOW¹³². The method consists of three phases.

- *Phase 1 - Analyze variant-related problem:* Systemic variant management starts with the identification of a variant-related problem. This can be general changes such as a changing cost structure in the company or changes in specific departments in

130. [Schuh and Jonas, 1997], p. 27.

131. [Matern, 2000].

132. [Rathnow, 1993].

particular such as increasing purchasing costs. Checklists are provided to easier identify these variant-related problems. Then, a model of the problem and the surrounding system is constructed. This model is characterized by its constitutive components, its actors, time horizon, and objectives. In doing so, one needs to go beyond the symptoms that were detected using checklists and identify the underlying variant-related problem.

- *Phase 2 - Operationalize problem and quantify measures:* The decision maker looks for different alternatives that may solve the problem identified in Phase 1. Alternatives can generally be characterized as measures belonging to variant reduction, prevention, or handling as introduced in Subsection 2.2.2. These measures can address the variety offered to the customer, personal/financial resources and corporate organization as well as processes. In the next step, the different alternatives are evaluated using the model designed in Phase 1. Indicators that allow the decision maker to assess the alternatives are identified.
- *Phase 3 - Evaluate measures:* The results of the assessment in Phase 2 are critically evaluated. The decision maker then chooses one of the alternatives to be implemented.

Systemic variant management also includes a model of the product family, which is based on the morphological matrix by ZWICKY¹³³. In this matrix, the principal and auxiliary functions are listed line by line. In Figure 3-4, it is shown that the variants of these functions corresponding to physical module variants are listed column by column. A particular product can be described as a line connecting the respective module variants.

Systemic variant management is more of a comprehensible framework for structuring different measures within variant management than an operational method to evaluate and improve concepts in variant management of modular product families in the market phase (4, 5, 8). It is stated that measures should be assessed and decided on based on indicators (6). It remains unclear, though, what these indicators are or how one should determine them. Neither uncertainty nor risk are considered (7). Still, the framework can be used to easily capture the product structure of a modular product family (1, 3). Due to practical size limitations of the

133. [Zwicky, 1989], pp. 114-162.

morphological matrix, the number of final products within the product family, however, needs to be limited. Finally, interfaces between modules are not captured (2).

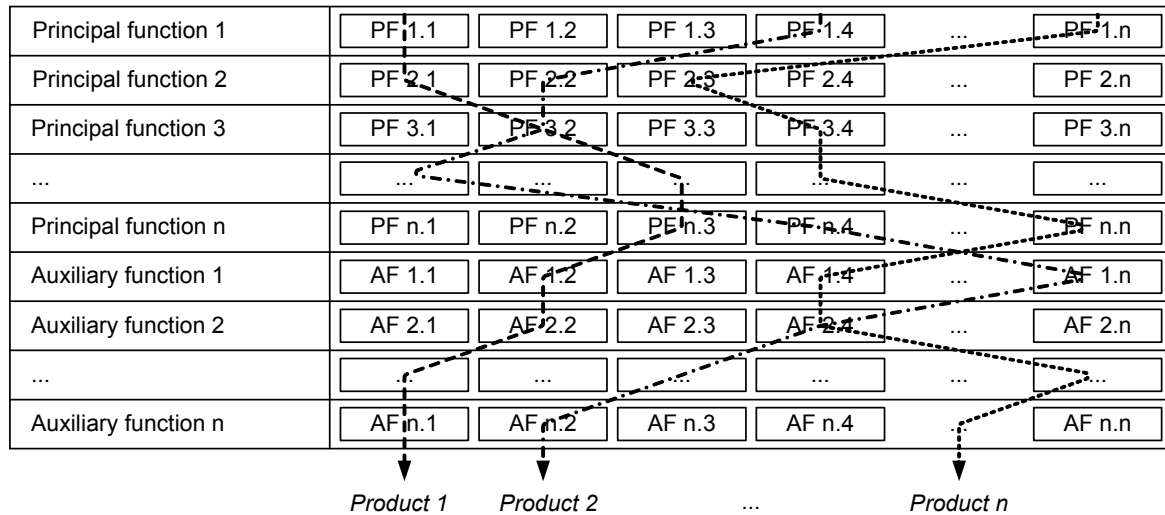

Figure 3-4: Morphological matrix for modular product family, based on MATERN¹³⁴

Balanced Scorecard for Modular Product Families

The balanced scorecard as proposed by KAPLAN & NORTON¹³⁵ is a method to measure the performance of a department or entire corporation from different perspectives. Generally, the financial, customer, business process, and learning perspectives are considered. Performance metrics for each of the four perspectives are summarized on a scorecard. In its original sense, the balanced scorecard is used to translate strategy into concrete steps.

JUNGE¹³⁶ applies the balanced scorecard to plan and control the development of modular product families. In this context, the perspectives on the balanced scorecard are changed to finance, development, marketing, and manufacturing. 15 objectives for applying modular product families grouped into the four perspectives are identified based on an empirical study. Performance metrics are assigned to these objectives and placed on the balanced scorecard. The structure of the resulting balance scorecard is shown in Figure 3-5. Application of the balanced scorecard for modular product families proceeds in the following steps.

134. [Matern, 2000], p. 90.

135. [Kaplan and Norton, 1996], pp. 7-18.

136. [Junge, 2005].

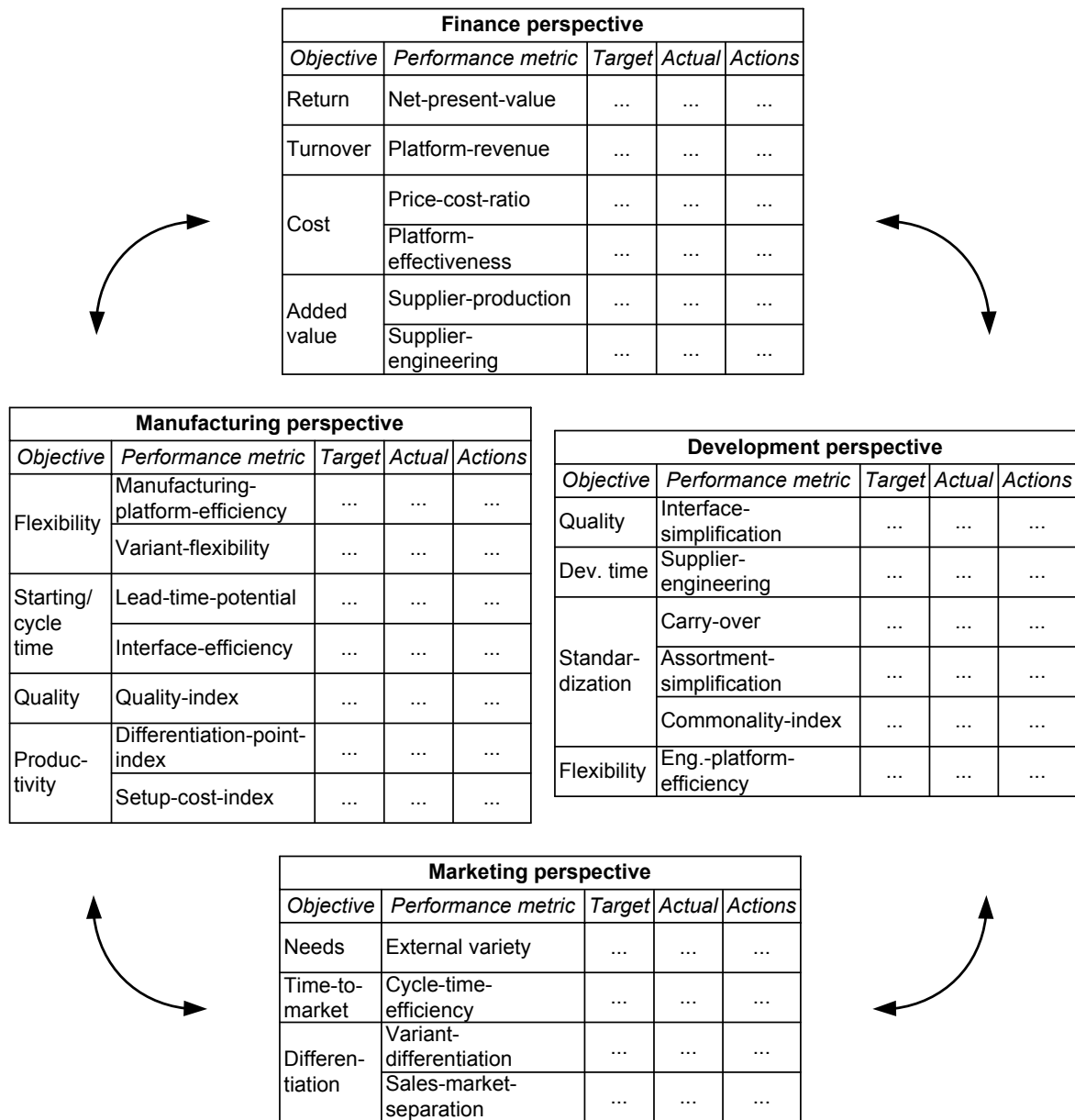

Figure 3-5: Balanced scorecard for modular product families, based on JUNGE¹³⁷

- *Product structure and process analysis:* The product structure of the modular product family is documented. This is done using a three-dimensional representation of blocks on a sheet of paper. Different modules are represented by different blocks and module variants of the same module are stacked on top of each other¹³⁸. Interfaces are documented by means of an interface matrix¹³⁹. If the product family is in the

137. [Junge, 2005], p. 180.

138. [Junge, 2005], p. 20.

139. [Junge, 2005], p. 193.

development phase, this can be done freely. If the product family is in the market phase, the product structure is given. In the development phase, manufacturing processes are also analyzed in order to determine the product structure from a manufacturing and logistics perspective.

- *Data compilation*: The data required for evaluating the performance metrics is compiled using interviews with employees from respective departments as well as corporate databases and publications. Data is aggregated in tables and diagrams.
- *Performance metric evaluation and visualization*: The performance metrics are evaluated using data from the previous step. Data is visualized using diagrams.
- *Generation of balanced scorecard*: The four perspectives and objectives within these are listed on a balanced scorecard. Moreover, the performance metrics are given with their target and actual value for each of the objectives. The balanced scorecard is then used to identify those objectives where the actual value is inferior to the target value. Finally, the decision maker determines actions to bring the actual value closer to the target value.

The balanced scorecard for modular product families allows the user to safeguard the product structure (1). The interface matrix can be used to indicate the existence of an interface between two modules (2). Additional information about an interface, however, cannot be laid down. The balanced scorecard can also be applied to show the difference between the target and the actual value for different performance metrics. The implementation effort largely depends on the performance metrics chosen (3, 8). Its primary functions are to quantitatively (6) identify fields where the modular product family is currently weak (4, 5) and to help find steps to resolve this. As such, the balanced scorecard is based on past performance and can only be used to check whether a concept addresses the right field. It can, however, not be used to quantitatively evaluate and improve concepts in variant management of modular product families in the market phase. Such a method would have to be based on the future performance of a concept. JUNGE, however, evaluates the past performance of the entire product family. Finally, uncertainty and risk are not considered in the application of the balanced scorecard (7).

3.2.2 Methods for Safeguarding Key Properties

In this subsection, related work for safeguarding the key properties of modular product families is summarized and evaluated.

Generic Information Platform

SIVARD¹⁴⁰ provides a computer-based model of product information concerning product platforms and families. The purpose of the generic information platform is to ‘define and describe the core of product family information.’¹⁴¹ The information platform consists of two main parts. These are the product family model, which is a generic product structure with alternative solutions, and the reusable solutions libraries describing physical solutions, conceptual models, and specifications. Only the former is relevant in this context.

The product family model is based on the customer, functional, and physical domains from axiomatic design¹⁴². Axiomatic design is anchored in the theory of domains. According to axiomatic design theory, design is a zigzagging between the customer, functional, physical, and process domains. Parameters are determined in each of the domains. These are customer needs (CN) in the customer domain, functional requirements (FR) in the functional domain, design parameters (DP) in the physical domain, and process variables (PV) in the process domain. In a good design, the mappings between the parameters of the domains fulfil two axioms, namely the independence and the information axiom¹⁴³. According to the independence axiom, DPs should fulfill the FRs independently. Ideally, each DP fulfills one FR. The information axiom states that of all solutions satisfying the independence axiom, the one having the highest probability of satisfying the FRs should be chosen.

SIVARD documents a product family by tracing the zigzagging between the customer, functional, and physical domains. The graphic notation is shown in Figure 3-6.

140. [Sivard, 2000].

141. [Sivard, 2000], p. 100.

142. [Suh, 1990], [Suh, 2001].

143. [Suh, 1990], p. 47.

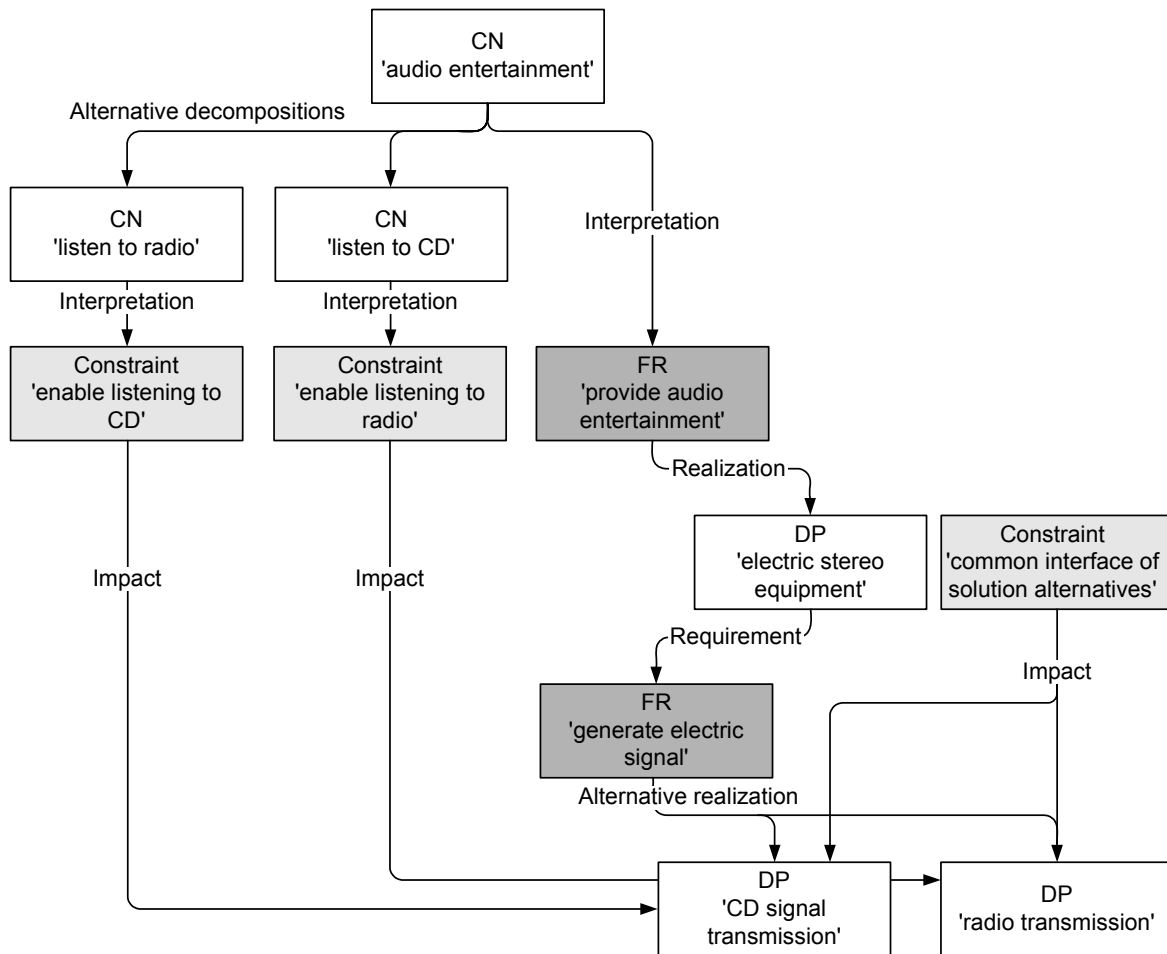

Figure 3-6: Product family model, based on SIVARD¹⁴⁴

This starts with one or several customer needs that are decomposed into more detailed customer needs. The customer needs are then interpreted by functional requirements, which are in turn realized by design parameters. Finally, there are constraints, which do not need to be mapped directly onto design parameters but rather impact design parameters originating from other functional requirements.

The information platform facilitates safeguarding of the product structure by modeling it as design parameters (1). Variety may also be accounted for by using alternative decompositions and constraints. Interfaces can be depicted as boxes in the product family model (2). The name of the interface and the modules related to this interface can therefore be given. In the context of a method for variant management of modular product families in the market phase, however, name and location of the interface alone are insufficient. In order to safeguard interfaces, a more

144. [Sivard, 2000], p. 122.

concrete specification needs to be given. Moreover, there are three reasons why the information platform requires significant resources (3). First, the method explicitly requires axiomatic design. Second, in order to apply the information platform, the design process of the product family with its customer needs, functional requirements, and design parameters needs to be recorded. This can be hardly achieved if one deals with an already existing modular product family. Third, the diagrams to capture the product family quickly become very extensive and complex.

Design Structure Matrix

The design structure matrix (DSM) is a broadly applied method to represent and analyze systems¹⁴⁵. A primary application of DSMs is the capturing of product structure and interactions among modules¹⁴⁶. In this context, the modules are listed on the x- and y-axes in Figure 3-7. Crosses or numbers indicate interactions between two modules. Using numbers, the strength of the interaction can be quantified. PIMMLER & EPPINGER¹⁴⁷ also suggest differentiating between spatial, energy, information, and material interactions. Some authors apply clustering methods to determine a product structuring concept that minimizes interactions¹⁴⁸.

		A	B	C	D	E
Radiator	A		2 0 0 2			2 -2 0 0
	B	2 0 0 2				2 0 0 2
Heater core	C				1 0 0 0	
	D			1 0 0 0		
Condenser	E	2 -2 0 0	2 0 0 2			

Legend:

Spatial	S	E	Energy
Information	I	M	Materials

Figure 3-7: Design structure matrix, based on PIMMLER & EPPINGER¹⁴⁹

145. See [Malmqvist, 2002] for a review of DSMs for product modeling and [Browning, 2001] for a review of DSMs for decomposition and analysis.

146. [Browning, 2001], p. 293.

147. [Pimmler and Eppinger, 1994], p. 4.

148. [Pimmler and Eppinger, 1994], pp. 5-8, [Baldwin and Clark, 2000], pp. 49, 50, [Blackenfelt, 2000], pp. 5-8.

149. [Pimmler and Eppinger, 1994], p. 6.

The standard DSM only incorporates one hierarchical level of modules. Only part of the characteristics of a modular product family's product structure can therefore be captured and safeguarded (1). It is, however, possible to integrate multiple structural levels by splitting up rows and columns. The DSM can also be used to record the location of interfaces between modules and classify these into four generic types (2). A clearer specification of interfaces, configuration rules, and usage lists can, however, not be recorded using a DSM. It is therefore only partly applicable to the safeguarding of interfaces. The DSM is very compact (3). It quickly becomes overwhelming to the user for large systems, though.

Generic Product Structures

In the case of a single product, the product structure can be depicted as a bill of material or a block diagram as shown in Figure 2-9. If one faces a product family, one can either represent it as the collection of product structures of single products or the union of individual product structures. The latter approach results in a generic product structure.

Since generic product structures are not a single concept but rather a collection of different approaches to merge and represent the product structures of a product family, no common notation nor nomenclature exists for generic product structures. All approaches, however, incorporate a relationship in addition to the basic concept of a component having other components as parts (partonomy relation). Some examples of additional relationships used to construct generic product structures are described in the following.

- *Kind-of, classification, and taxonomy relations*: All these relationships refer to the same thing, namely that a component may be classified into several more specific components all belonging to the same class. A component 'engine' for instance might be further classified into 'combustion engine' and 'electric engine'. Examples of applications of this type of relationship in generic product structures can be found in VEEN¹⁵⁰, JIAO¹⁵¹, MÄNNISTÖ ET AL.¹⁵², and MESIHOVIC & MALMQVIST¹⁵³.

150. [Veen, 1992], p. 144.

151. [Jiao, 1998], p. 71.

152. [Männistö et al., 1999], p. 1112.

153. [Mesihovic and Malmvist, 2004], p. 3.

- *Cardinality*: In a product family, it may be possible to choose different quantities of a component. This is called cardinality¹⁵⁴. The feasible numbers are given in the generic product structure. This concept is used, for instance, in and KUNZ ET AL.¹⁵⁵ and MONTAU¹⁵⁶.
- *Configuration rules*: Using configuration rules, one can make a relationship between two components to be either active or inactive based on inputs from the customer. Variety within a product family can thus be modeled. This is applied in ERENS¹⁵⁷ and KUNZ ET AL.¹⁵⁸.

Some authors also provide a graphical notation of the generic product structure. The graphical notation is intended to give a quick overview and facilitate discussions regarding the generic product structure. An example of generic a product structure in EXPRESS-G notation¹⁵⁹ is shown in Figure 3-8.

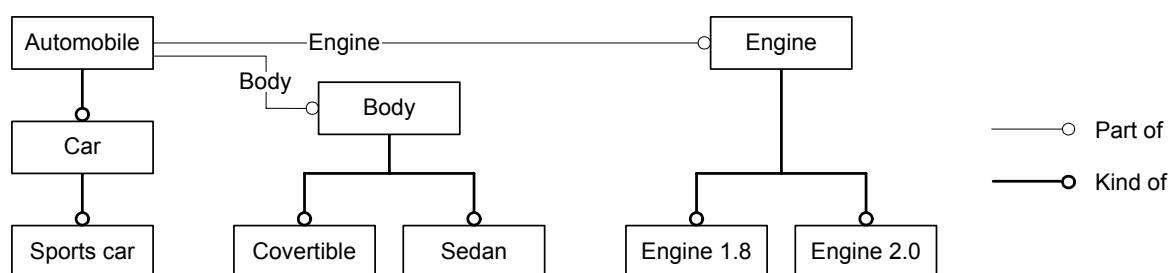

Figure 3-8: Generic product structure in EXPRESS-G, based on MÄNNISTÖ ET AL.¹⁶⁰

Generic product structures enable the user to safeguard the product structure of a modular product family by capturing the product structure down to the level of modules and accounting for variety within the product family (1). Interfaces are, however, not considered in the scope of a generic product structure (2). Some methods for generic product structures provide an easily understandable visual notation that can be rapidly applied (3).

154. [Oliver et al., 1997], pp. 38, 39.

155. [Kunz et al., 2004], p. 3.

156. [Montau, 1996], p. 128.

157. [Erens, 1996], pp. 138, 139.

158. [Kunz et al., 2004], pp. 2, 3.

159. EXPRESS-G is specified in [ISO10303-11, 2004], pp. 185-200.

160. [Männistö et al., 1999], p. 1112.

Model for Configurable Product Families

TIIHONEN ET AL.¹⁶¹ present an object-oriented model¹⁶² to capture knowledge in configuration of a modular product family. This model can, for instance, be applied if a configurator is introduced in a company. In configuration, one may distinguish between configuration model knowledge representing the set of theoretically feasible configurations, requirements knowledge representing the requirements of the customer used to carry out configuration, and configuration solution knowledge for an actual product configuration. The model proposed by TIIHONEN ET AL. is for configuration model knowledge. This model is also relevant here as it is capable of capturing the product structure of a modular product family.

The model includes four types of entities, namely components, ports, resources, and constraints. An example of a configuration model for a drilling boom assembly within a drilling machine is shown in Figure 3-9.

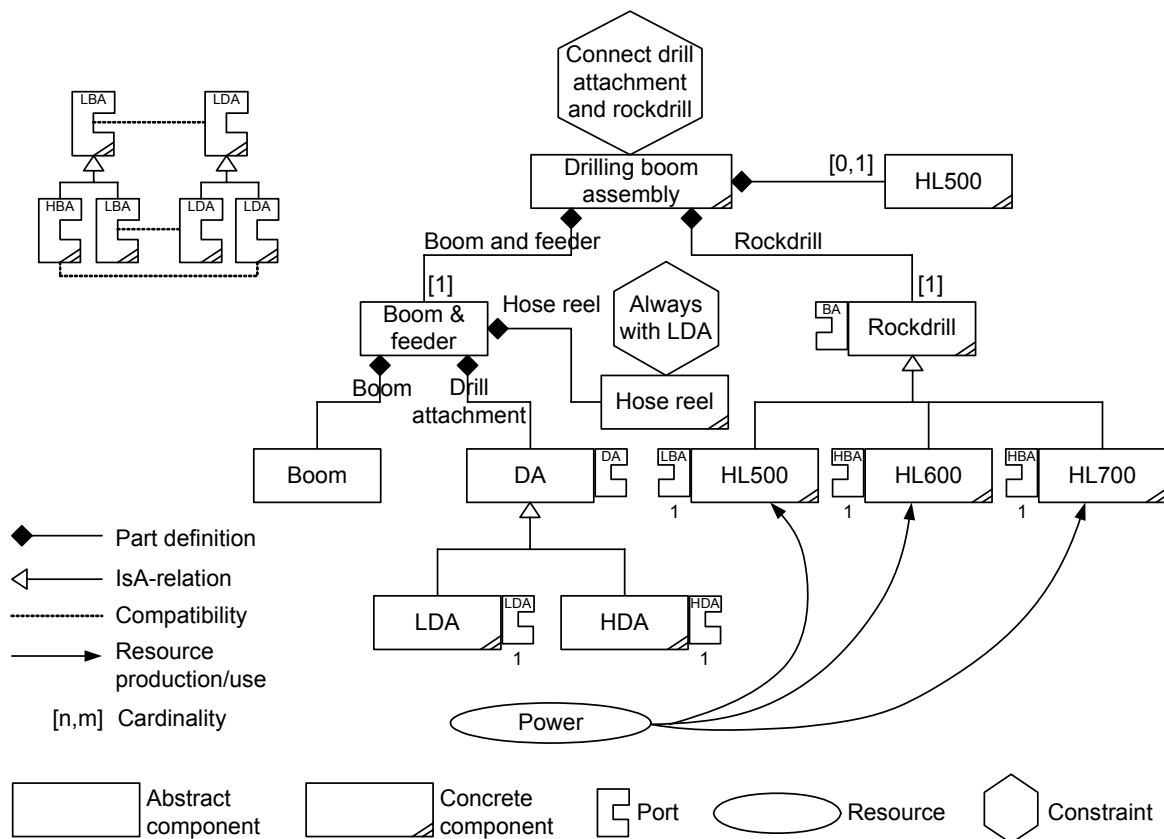

Figure 3-9: Model for configurable product families, according to TIIHONEN ET AL.¹⁶³

161. [Tiihonen et al., 1998].

162. The model is based on concepts from object-oriented modeling, see [Rumbaugh et al., 1991], pp. 296-333.

163. [Tiihonen et al., 1998], pp. 16, 22.

A component such as the ‘boom & feeder’ in Figure 3-9 is a distinguishable entity in a product family that is meaningful for configuration. In a modular product family, this will generally be a module or module variant. A component may have mandatory, alternative, and optional subcomponents. The ‘boom & feeder’ component, for instance, consists of the ‘boom’ and the ‘drill attachment’ subcomponents. Components are characterized by their name and cardinality, i.e. the number of admissible occurrences within the supercomponent they are part of. The ‘boom & feeder’ component occurs exactly one time in the ‘drilling boom assembly’. Ports are assigned to components to describe connections and compatibilities of the particular component. Resources, i.e. power in the context of Figure 3-9, are utilities produced by some components and consumed by others. They are linked to each other by resource relationships. Finally, there are constraints, which are formal rules specifying conditions that must hold for an allowed configuration. The ‘hose reel’, for instance, must always be chosen with the ‘LDA’ subcomponent.

Although the model for configurable product families was not developed for variant management but for configuration, it comes close to the requirement of safeguarding a modular product family’s key properties. It completely fulfills the requirement of safeguarding the product structure as the model can be used to build up product structures including variety (1). Interfaces can also be integrated using ports (2). The requirement of safeguarding interfaces is, however, only partly fulfilled as only the interface’s name and associated component are given. Moreover, the model includes such a large number of entities and relationships that it is rather difficult to understand and quite elaborate to apply (3).

Product Family Master Plan

MORTENSEN ET AL.¹⁶⁴ propose a five-step process for introducing a configurator. First, the configuration task is identified. Second, the so-called product family master plan is identified, which is a formal way of describing a product family. Third, each element within the product family master plan is described using its function, application, BOM, and so on. Fourth, the resulting model is transferred into the configuration language of the configurator to be introduced. Finally, the product model is implemented in the actual configurator.

164. [Mortensen et al., 2000], pp. 69-70.

The product family master plan proposed in the above context can also be used here for safeguarding key properties. The product family master plan comprises two elements, namely a generic part-of structure and a generic kind-of structure as shown in Figure 3-10. The part-of structure describes the modules, assemblies, and parts that exist within all products of the product family, while the generic kind-of structure describes the changeable modules, assemblies, and parts. Elements within the generic part-of structure are also described by attributes that are determined during configuration. Constraints on relations between parts are modeled as well.

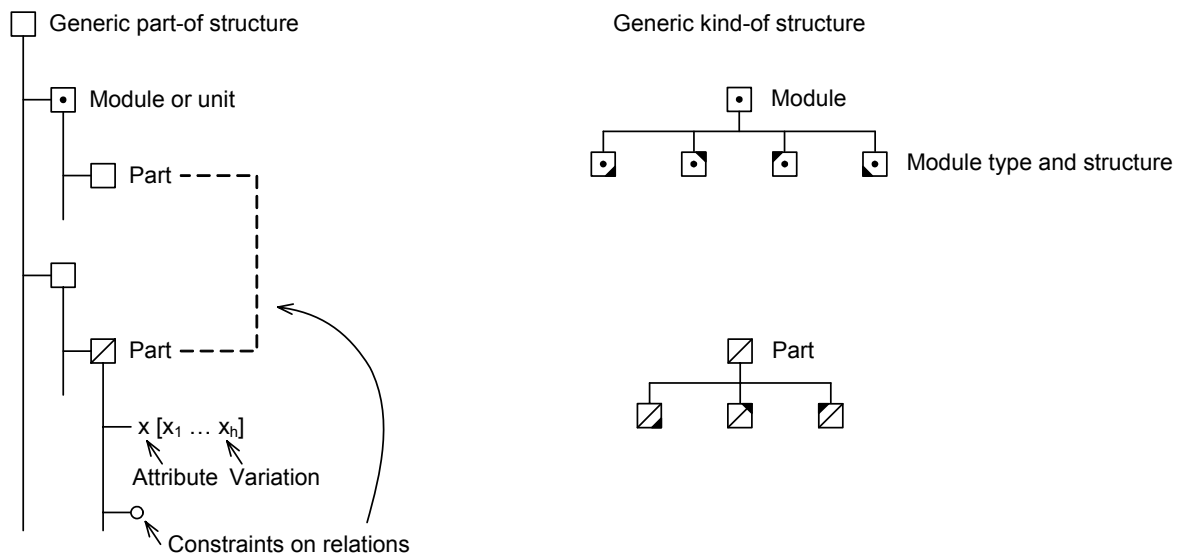

Figure 3-10: Product family master plan, according to MORTENSEN ET AL.¹⁶⁵

The product family master plan allows the decision maker to capture the product structure of a modular product family (1). One issue in doing so is, however, that part-of and kind-of relationships are strictly separated. It remains unclear how to model product families where part-of and kind-of relations alternate on different levels of the product structure. Besides, interfaces cannot be modeled using the product family master plan (2). The concept is relatively simple to understand because it is based on the well-known concept of BOMs (3). The strict separation of part-of and kind-of structure can, however, seem counterintuitive to the user.

165. [Mortensen et al., 2000], p. 70.

3.2.3 Methods for Evaluation/Improvement

There are numerous methods for concept selection. Many of the methods used are, however, not quantitative¹⁶⁶ and thus do not fulfill a fundamental requirement specified in Subsection 3.1.2. Only quantitative methods for concept evaluation and improvement are considered in the following.

Decision Matrix

Decision matrices are certainly the most widely used method for concept evaluation¹⁶⁷. They are proposed by many authors of engineering design textbooks¹⁶⁸. An example of a decision matrix is given in Figure 3-11. The evaluated concepts are listed by column and the various decision criteria by row. The different criteria may also be weighted. In this case, the concepts are evaluated using the weighted average of the criteria.

Criteria	Weight	Concept 1	Concept 2	Concept 3	Concept 4
Manufacturing cost	0.4	3	1	2	4
Development cost	0.2	4	3	3	2
Market demand	0.3	5	2	2	2
Technical maturity	0.1	3	5	2	1
Total score		3.8	2.1	2.2	2.7
Concept rank		1	4	3	2

1 = Far below average 2 = Below average 3 = Average 4 = Above average 5 = Far above average

Figure 3-11: Decision matrix

Despite their wide application, decision matrices have been criticized for being based on an inadequate construct. The decision matrix may represent a concept as less desirable even though no other concept scores better in at least one criterion while being at least as good in all others¹⁶⁹ (4). Besides, the decision matrix is only partly applicable to the improvement of concepts (5). This is because the factors that influence the decision criteria are not shown. Only

166. See for instance, [Ulrich and Eppinger, 2003], pp. 130-134 and [Ullman, 2003], pp. 181-184.

167. [Mattson and Messac, 2005], p. 88.

168. [Pahl and Beitz, 1996], pp. 102-116, [Ullman, 2003], pp. 185-188, [Dieter, 1991], p. 153, [Magrab, 1997], p. 130, and also [VDI2225, 1998], p. 4.

169. That is to say that non-dominated concepts lying in non-convex regions of the Pareto frontier may not receive the highest total score, see [Mullur et al., 2003], pp. 4-7.

the final score of the decision criteria is given. The decision matrix provides only limited indications for improving concepts. Decision matrices are semi-quantitative (6). Although the values of the decision criteria are measured quantitatively, the determination of these values is often arbitrarily selected by the decision maker. Uncertainty and risk are generally not considered in the application of decision matrices (7). OTTO & WOOD¹⁷⁰ have, however, proposed to integrate risk by assigning confidence intervals to the values of decision criteria. The decision matrix is very intuitive and readily applicable (8). It can be hard to gather solid data basis for the values of the decision criteria, though.

Product Planning of Multiple-Variant Products

KUNZ¹⁷¹ provides a process model for planning multiple-variant products. The main phases in this process model are strategic and operative product planning.

- *Strategic product planning*: The outcome of strategic planning is a variant strategy comprising the definition of the overall product families to be offered and the degree of product customization. In the first step of strategic product planning, the current product portfolio of the company is analyzed using economic criteria such as sales, profit, and contribution margin. A gap between the desired and the actual value of these criteria is identified. Besides, current trends in the economic environment are examined. This analysis is used to define product-related objectives in the next step. These are generally given in terms of quantitative criteria like sales and profit. Moreover, the target markets for the company's products are selected. Next, a concrete course of action is chosen. Five approaches can generally be differentiated, namely broad market penetration/expansion, selective market penetration/expansion, holding the current market position/no action, selective elimination, and complete elimination. In the final step, the gap identified in the first step is closed by defining concrete product families corresponding to the previously determined course of action.
- *Operative product planning*: In this phase, product variants, modules, and module variants are considered. First, the individual product families are analyzed. The end products within a product family, which are configured from the modules, are

170. [Otto and Wood, 2001], pp. 513-532.

171. [Kunz, 2005].

assessed using key economic criteria. These criteria are the same as those used in strategic product planning. This is also done for the individual modules that are used to configure the end products. Second, a course of action is specified that is aligned with the variant strategy. On the level of end products, new product variants may be developed and variants or even an entire end product may be eliminated from the product portfolio. The same may be done on the level of modules. In the final step, concrete products and modules are defined.

KUNZ supports the decision of defining new products and modules using an ABC analysis-based¹⁷² method. In operative product planning, an ABC analysis of modules is carried out based on sales and contribution margins of different modules. The market segments that the modular product families are targeted for are also ranked using ABC analysis of the contribution margin within the respective segment. The results are visualized in a matrix such as the one shown in Figure 3-12.

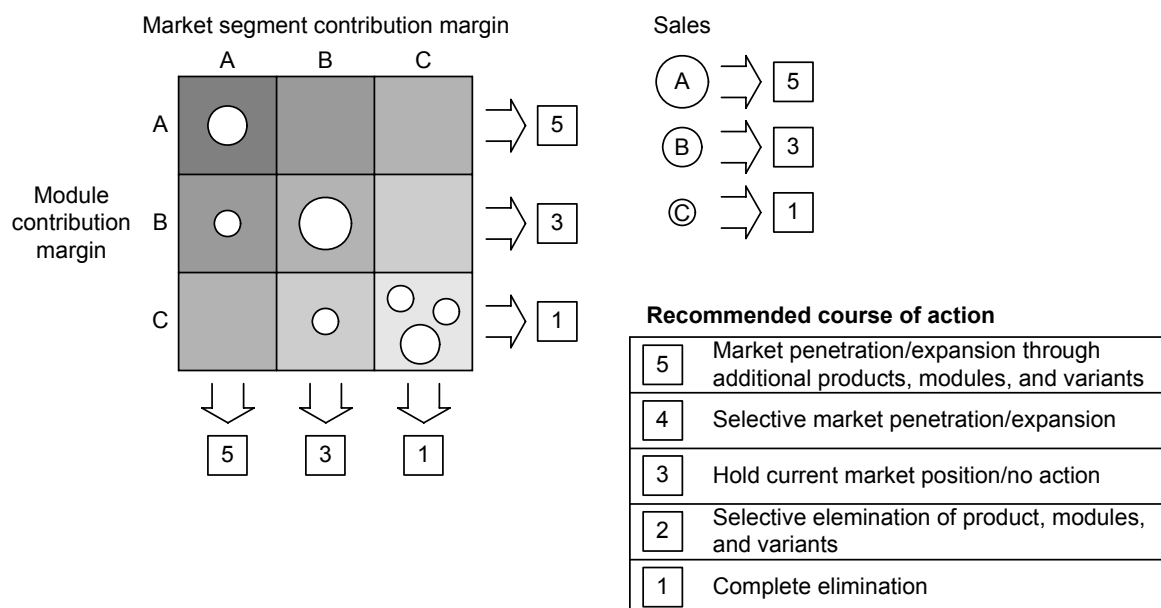

Figure 3-12: Product planning of multiple-variant products, based on KUNZ¹⁷³

In this matrix, modules are depicted as circles with the size of the circle indicating a module's sales. The circles are positioned in the matrix based on an individual module's contribution margin (y-axis) and the overall contribution margin of the market segment it belongs to (x-axis).

172. [Daenzer and Büchel, 1986], p. 188.

173. [Kunz, 2005], p. 150.

Different modules are evaluated by giving five points to A-products, three points to B-products, and one point to C-products. This is done for all of the three relevant categories, i.e. sales, module's contribution margin, and market's contribution margin. The average of these three values is used to recommend courses of action ranging from market penetration and enhancement through additional modules and variants to the complete elimination of modules.

The primary contribution of the work presented by KUNZ is the application of variant management to the task of product planning. Additionally, the above-described matrix-based method is used to identify segments of the market where it may be feasible to introduce new modules and variants or eliminate dispensable ones. This is based on abstract market criteria such as contribution margin and sales. Only the past performance of markets and modules is taken into account. The concrete properties of a concept for a new module or module variant are not considered. The resulting effects on various stakeholders in the corporation are not taken into consideration. As a result, the method is incomplete in terms of the decision criteria and only partially applicable to the evaluation of concepts (4). Its primary area of application is the identification of potential fields of action. Neither can it be used to improve concepts (5). Uncertainty and risk are not incorporated (7). Still, the matrix-based method can be applied rapidly using readily available quantitative data (6, 8).

Utility-Based Optimization Methods

Several individual methods for evaluating and improving concepts for new modules and variants fall into the category of utility-based optimization methods. Utility theory goes back to MORGENSTERN & NEUMANN¹⁷⁴. It is based on the concept of a basic lottery with two outcomes. Six axioms govern this lottery¹⁷⁵. These are applied to construct utility functions, where a utility function is the mapping from the decision attribute to its desirability. KEENEY & RAIFFA¹⁷⁶ expand this concept to multiple decision attributes. The system architecture of utility-based optimization methods is shown in Figure 3-13.

174. [Morgenstern and Neumann, 1947].

175. [Morgenstern and Neumann, 1947], pp. 26, 27.

176. [Keeney and Raiffa, 1976].

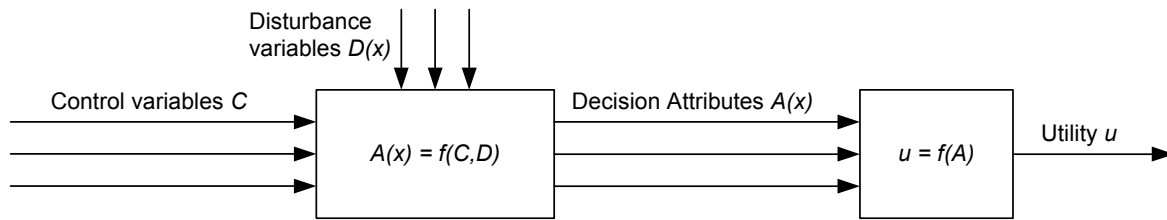

Figure 3-13: System architecture of utility-based optimization methods

The decision attributes, which are the outcome of a decision, are the result of the control variables that can be influenced by the decision maker and disturbance variables that cannot be influenced. The values of the disturbance variables are generally described by probability distributions. Consequently, the values of the resulting decision attributes are also governed by probability distributions. The objective in all utility-based methods consists of maximizing the expected utility of the decision outcome. There are several utility-based optimization methods suitable for concept evaluation and improvement. They are described in the following.

- *Utility-based decision support for selection*: FERNÁNDEZ ET AL.¹⁷⁷ propose a utility-based method for selection, which they apply to the evaluation of several concepts of a new light switch cover plate. Only the right box of the system architecture shown in Figure 3-13 is used in applying the method. First, the alternative concepts and relevant decision attributes are described. Then, probability distributions are determined for each decision attribute and each concept. In the next step, the decision maker specifies utility as a function of the single decision attributes and thus obtains the individual utility functions. These utility functions are combined into the overall multi-attribute utility function. The most promising concept is selected. In order to validate this selection, post solution analysis is carried out by checking whether the results logically make sense.
- *Heuristic for product line selection*: GREEN & KRIEGER¹⁷⁸ approach the problem from the perspective of a manufacturer facing a range of potential new products to launch on the market. The task consists of choosing the most useful of these new products. To solve this task mathematically, a utility from the buyer's perspective is assigned to each potential new product. Similarly, a utility is assigned from the manufacturer's perspective. The new product will be bought by a customer if its

177. [Fernández et al., 2001].

178. [Green and Krieger, 1985].

utility from a buyer's perspective is above a specific threshold. The entire task is formulated as a mathematical optimization problem. This is generally extremely complex and can only be solved heuristically. Disturbance variables are not considered and uncertainty is therefore not accounted for. The method was envisaged to be evaluate new products. It may be possible, though, to augment it for existing product families. Finally, it is not applicable to the improvement of new product as the factors influencing the buyer's and manufacturer's utilities are not shown.

- *Product design selection under uncertainty*: LI & AZARM¹⁷⁹ suggest generating concepts for new products by entering different design parameters as control variables and observing the resulting values of the decision attributes. This is the left box in Figure 3-13. The actual demand from the customer is a function of these attributes. Using demand and the projected lifecycle costs of the new product, its expected net present value is calculated. Similarly, the market share is calculated from demand. A utility function (right box) is assigned to both net present value and market share. Finally, the expected overall multi-attribute utility is used to evaluate concepts. Since the factors that influence a concept's utility are explicitly modeled in the above-described left box, it may also be used to improve concepts. The method is quantitative. Uncertainty and risk are considered.

Although the described utility-based optimization methods were originally conceived for decisions in single-product development (FERNÁNDEZ ET AL., LI & AZARM) or the design of a product family as a whole (GREEN & KRIEGER), they can be applied to the evaluation and improvement of concepts in the context of variant management of modular product families in the market phase (4, 5). All of the methods are quantitative (6) and most of them account for uncertainty and risk (7). The primary drawback is that all utility-based optimization methods are extremely cumbersome to implement (8). All methods require a new optimization model for every new concept for a new module or module. This is because the interrelationship between control/disturbance variables and the decision attributes is different for every single concept. Considering the fact that methods for quantitative decision support of variant management of modular product families in the market phase are currently barely applied, one realizes that the resources required for utility-based optimization are prohibitive.

179. [Li and Azarm, 2000].

3.3 Research Gap

The results of the previous section’s evaluation of related work are summarized in Figure 3-14. It is distinguished between methods that facilitate both safeguarding of key properties as well as evaluating/improving concepts (Subsection 3.2.1) and methods that are only for safeguarding of key properties (Subsection 3.2.2) or evaluating and improving concepts (Subsection 3.2.3).

		Safeguard key properties				Evaluate and improve concepts				
		1. Product structure	2. Interfaces	3. Resources	4. Evaluation	5. Improvement	6. Quantitative	7. Uncertainty/risk	8. Resources	
Subsection 3.2.1	Variant mode and effects analysis (CAESAR, SCHUH & TANNER)	●	○	●	◐	◐	●	○	◐	
	Systemic variant management (MATERN)	◐	○	●	◐	◐	○	○	◐	
	Balanced scorecard for modular product families (JUNGE)	●	◐	●	◐	○	●	○	◐	
Subsection 3.2.2	Generic information platform (SIVARD)	●	◐	○	Not addressed					
	Design structure matrix (PIMMLER & EPPINGER)	◐	◐	◐						
	Generic product structures (VEEN, JIAO, MANNISTÖ ET AL., ...)	●	○	◐						
	Model for configurable product families (TIIHONEN ET AL.)	●	◐	◐						
	Product family master plan (MORTENSEN ET AL.)	◐	○	◐						
Subsection 3.2.3	Decision matrix (PAHL & BEITZ, ULLMAN, DIETER, ...)	Not addressed			◐	◐	◐	◐	●	
	Product planning of variant products (Kunz)	Not addressed			◐	○	◐	○	●	
	Utility-based optimization methods (FERNÁNDEZ ET AL., LI & AZARM, ...)	Not addressed			●	◐	◐	◐	○	

○ Not fulfilled ◐ Barely fulfilled ◑ Partly fulfilled ◒ Mostly fulfilled ● Completely fulfilled

Figure 3-14: Evaluation of related work

The difference between the requirements laid down in Section 3.1 and the actual performance of the evaluated methods is the research gap. Methods addressing both the safeguarding of key properties and evaluation and improvement fall short in the following aspects.

- *Not practical for improvement*: None of the methods allows the factors that influence the utility of a concept of new module or variant to be modeled explicitly. The methods cannot be used to guide the decision maker to steps that could be taken to improve concepts. As a result, the methods are not practical for improvement.

- *Uncertainty and risk not considered:* Uncertainty with respect to the future and the resulting risk in the outcome of the decision criteria are important aspects of engineering design. This is particularly true for decisions in variant management of modular product families in the market phase, which have a time horizon of several years. Still, uncertainty and risk are not considered in any of the evaluated methods.
- *Interfaces not considered:* Although interfaces between modules are a key property of a modular product family, CAESAR¹⁸⁰ and MATERN¹⁸¹ do not cover them at all. JUNGE¹⁸² uses an interface matrix to merely indicate the existence of an interface between two modules. Additional information with respect to interfaces is not considered.
- *Not immediately applicable:* None of the related methods has been conceived specifically to support future-oriented decisions in variant management of modular product families in the market phase. CAESAR and MATERN are limited in that they address variant management in general and are therefore quite abstract. JUNGE seeks to control modular product families using information on past performance. The decision support needed here, however, has to be based on future performance. As a result, the methods either need to be made more operational or adapted in order to be applicable to variant management of modular product families in the market phase.

Even at the level of the two individual functions, no method currently exists that completely fulfills the requirements of one of the two functions. The research gap for the safeguarding of key properties is the following.

- *Interfaces not considered:* In generic product structures and MORTENSEN ET AL.¹⁸³, interfaces are not considered at all. SIVARD¹⁸⁴ and TIIHONEN ET AL.¹⁸⁵ suggest modeling interfaces as boxes. In the design structure matrix, interfaces can be captured using crosses and numbers. Only location and type of an interface can thus be safeguarded. Additional aspects such as the concrete geometric or electronic layout are not considered.

180. [Caesar, 1991].

181. [Matern, 2000].

182. [Junge, 2005].

183. [Mortensen et al., 2000].

184. [Sivard, 2000].

185. [Tiihonen et al., 1998].

The following research gap can be identified in terms of the function of evaluating and improving concepts.

- *Uncertainty and risk not considered*: KUNZ¹⁸⁶ does not consider uncertainty and risk in making decisions in variant management of modular product families in the market phase. Similarly, uncertainty is not part of the decision matrix. Uncertainty and risk are considered in the scope of utility-based optimization methods. These, however, require so much resources for their implementation and use that they may be considered unsuitable for industrial application.

3.4 Research Question

Two conclusions can be drawn from the reflection on the research gap in the previous section. First, none of the existing methods fulfills all requirements, neither as a whole nor among the two single functions. Second, the methods meeting the highest number of requirements, which have been described in Subsection 3.2.1, are not directly applicable because they are too abstractly formulated. The resulting research gap can be closed by answering the following research question.

What is an operational method to support decisions in variant management of modular product families in the market phase that allows the decision maker to safeguard the modular product family's key properties as well as to evaluate and improve concepts for new modules and module variants?

Three approaches can be taken to provide such a method. First, existing methods can be augmented to fulfill more of the requirements. This applies to the module for configurable product families by TIIHONEN ET AL., which may be augmented with a concept to safeguard interfaces. Second, the methods that require too many resources such as the utility-based optimization methods can be simplified. Third, new methods can be introduced. All three approaches are used for the variant management funnel described in the next chapter.

186. [Kunz, 2005].

Chapter 4

Variant Management Funnel

In the previous chapter, the research question has been laid down. The variant management funnel, which is intended to be the answer to this research research question, is presented in this chapter. The variant management funnel comprises three tools, namely the framework for modular product families, module sheets, and probabilistic evaluation and improvement. The framework for modular product families and module sheets are applied in the compatibility screen of the variant management funnel, while probabilistic evaluation and improvement is applied in the stakeholder screen. An overview of the variant management funnel is given in Section 4.1. The three above-mentioned tools, which are part of the variant management funnel, are described in a separate section each.

4.1 Outline of Variant Management Funnel

WHEELWRIGHT & CLARK¹⁸⁷ state that any development project may be interpreted as a funnel. The product and process concepts generated in various parts of the corporation enter the funnel and go through one or several screens. The screens are used to carefully examine concepts in order to discard, evaluate, and improve them. Once a concept passes the final screen, it enters strict development as defined in Subsection 2.1.2. At this stage, it should not be stopped anymore but should be carried to market launch. Variant management of modular product families in the market phase is nothing but a special type of development project¹⁸⁸. Hence, the development funnel may be applied. The proposed variant management funnel is shown in Figure 4-1. It is applied in the market phase of the modular product family, when the decision

187. [Wheelwright and Clark, 1992], pp. 111-132.

188. In variant management of modular product families in the market phase, one deals with derivative development projects as defined in [Ulrich and Eppinger, 2003], pp. 35, 36.

maker repeatedly faces concepts for new modules and module variants that may be incorporated into the existing product family.

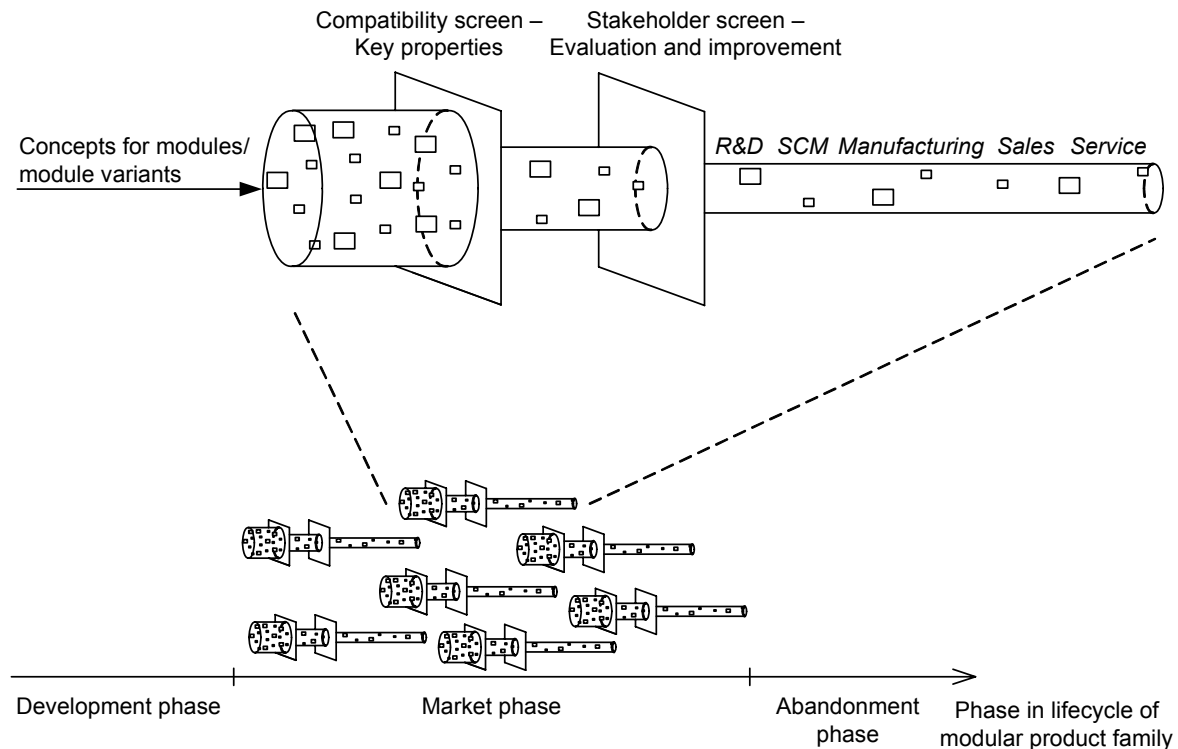

Figure 4-1: Variant management funnel

WHEELWRIGHT & CLARK¹⁸⁹ identify three tasks in the management of a development funnel.

1. *Ensure stream of concepts*: One needs to make sure that there constantly is a significant number of concepts for new products.
2. *Set up screens*: It is necessary to set up appropriate screens. These screens have to be carefully designed so that useful concepts may pass through, while unprofitable concepts are discarded.
3. *Manage development projects*: One needs to make sure through good project management that those concepts that pass the final screen meet the anticipated objectives.

Only the second task is relevant to variant management of modular product families in the market phase. That is why the two screens that are used to discard, evaluate, and improve concepts for modules and module variants are the primary topic of this chapter.

189. [Wheelwright and Clark, 1992], pp. 112, 113.

As discussed in Section 3.1, a method for variant management of modular product families in the market phase should fulfill two functions. First, it should support the user in safeguarding the key properties of the modular product family. These have been identified to be its product structure and interfaces. Second, it should enable the decision maker to evaluate and improve concepts based on decision criteria derived from the variant strategy. The decision criteria are evaluated across all stakeholders in the company involved in the innovation process. Within the proposed variant management funnel, each of these two functions is fulfilled by a separate screen.

- *Compatibility screen - Key properties:* The first screen is used to check if the proposed concept for a new module or module variant violates the key properties of the modular product family. This is supported by two tools. First, the framework for modular product families is provided in Subsection 4.2. This framework provides an easily understandable representation of the modular product family's product structure. It is used by the decision maker to check whether a proposed concept is compatible with the existing product family in terms of the product structure. Second, module sheets are described in Section 4.3. Using module sheets, one can specify the interfaces of modules within the modular product family and any additional properties of a module that are to be safeguarded in variant management. They are used to decide whether a concept is compatible with the existing product family in terms of interfaces.
- *Stakeholder screen - Evaluation and improvement:* Only concepts that are compatible with the modular product family, i.e. safeguard its product structure and interfaces, pass through to the stakeholder screen. Within this screen, concepts are evaluated and improved based on one or several decision criteria. These criteria are derived from variant strategy. The actual values for the decision criteria are obtained by analyzing the effects of a proposed concept along the innovation process. In doing so, both expected value and associated risk are taken into account. This is discussed in detail in Section 4.4.

In order to facilitate understanding, a flowchart of how to use the variant management funnel is shown in Figure 4-2. This includes the individual steps and documents in the variant management funnel and also the three supporting tools, which are described in the remaining three sections of this chapter.

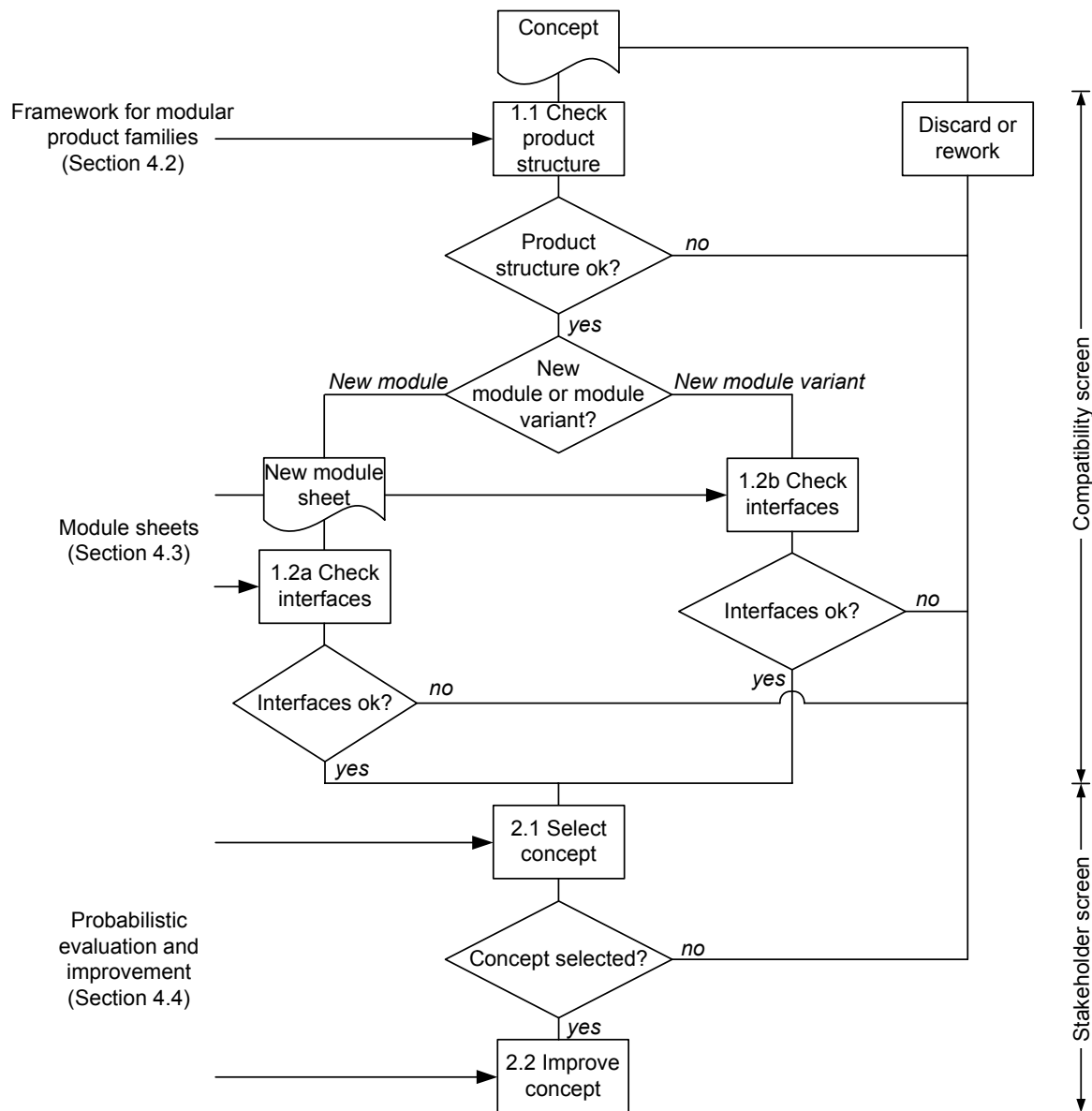

Figure 4-2: Flowchart of variant management funnel

The inputs into the funnel are concepts for new modules or module variants. The first step (1.1) is to check if and where such a concept fits into the product structure of the modular product family. This is carried out using the framework for modular product families, which is the topic of Section 4.2. If the concept is incompatible, it may either be discarded or reworked. If the concept is for a new module, a new module sheet is created for the respective module. It is also necessary to check whether the interfaces specified in the new module sheet are compatible with the interfaces in existing module sheets (1.2a). Module sheets are described in Section 4.3. If the concept is for a new module variant, one does not need to create a new module sheet. In this case, the existing module sheet of the superordinate module applies. The decision maker checks

if the proposed concept satisfies the interfaces specified there (1.2b). If the concept is not compatible, it may be discarded or reworked.

All concepts that pass the compatibility screen meet the minimum requirements for a new module or module variant within variant management of a modular product family in the market phase. Using probabilistic evaluation (2.1), the decision maker selects the most suitable concept. The decision maker may also not select a concept because none of them is expected to be beneficial. In this case, the product family will not be augmented and the existing concepts are discarded or reworked. If the decision maker selects a concept, then this concept is improved (2.2). Probabilistic evaluation and improvement is discussed in Section 4.4. Finally, the improved concept leaves the variant management funnel and becomes a development project.

In each of the following sections, the respective tool is presented first. Besides, an integrative example of a modular product family of concrete mixers is used to exemplify the framework for modular product families, module sheets and probabilistic evaluation and improvement. Finally, it is shown how each respective tool can be implemented in a company.

4.2 Framework for Modular Product Families

The framework for modular product families is used as part of the compatibility screen for deciding whether a proposed concept is compatible with the product structure of the existing modular product family. This is Step 1.1 in Figure 4-2 and is meant to fulfill Requirements 1 and 3 described in Section 3.1. In this section, the framework for modular product families as a tool is explained and an illustrative example is given. It is also described how to implement the framework.

4.2.1 Tool

The product structure of a modular product family is different from a single product in that it includes variety. MONTAU¹⁹⁰ and KUNZ ET AL.¹⁹¹ point out that one needs to distinguish between three types of variety, which are depicted in Figure 4-3.

190. [Montau, 1996], pp. 128, 129.

191. [Kunz et al., 2004], p. 2.

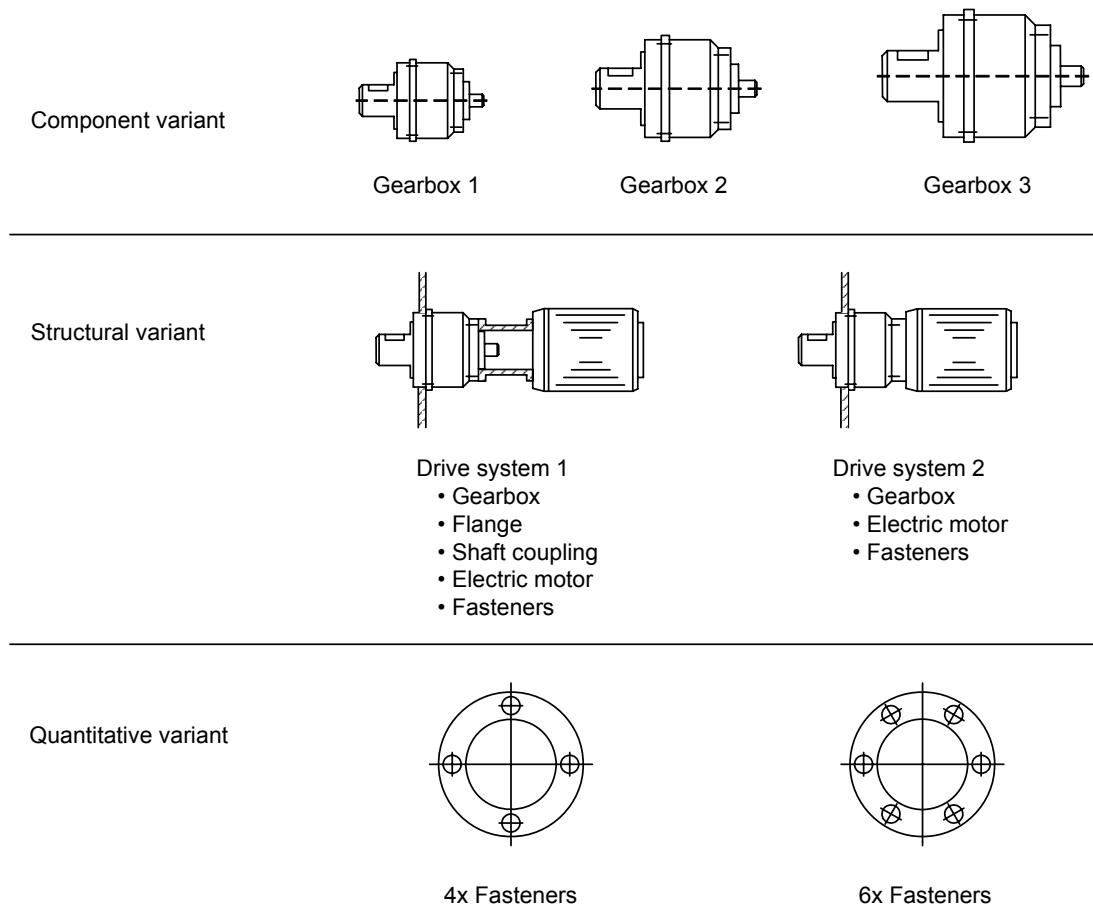

Figure 4-3: Types of variety in a modular product family, based on MONTAU¹⁹²

The three types of variety have the following characteristics.

- *Component variant*: There are several types of components. These components may be both single parts or entire assemblies. Each component is a component variant. In the example of Figure 4-3, each of the three gearboxes, ‘gearbox 1’, ‘gearbox 2’, and ‘gearbox 3’, is a component variant. The structure of the three gearboxes is the same but the parts they are made of are different. In the context of modular product families, the three gearboxes could be module variants of a more general module called ‘gearbox’. In this case, the three module variants would constitute component variants of the module ‘gearbox’.
- *Structural variant*: A component of the product structure may have different structural relations to its constitutive components one level further down in the product structure. Each single set of structural combinations is a structural variant. In

192. [Montau, 1996], p. 129.

Figure 4-3, the second drive system includes gearbox, electric motor, and fasteners, while the first also includes flange and shaft coupling. The difference between a component and a structural variant is that in a component variant, variety is in the constitutive components, while in a structural variant, variety is in the structural relation. In the context of modular product families, the two drive system could be module variants of a module called ‘drive system’. The module variants would thus constitute structural variants.

- *Quantitative variant*: The quantity of constitutive components that a higher component is made of, i.e. its cardinality, may vary. The cardinality of fasteners in Figure 4-3, for instance, may either be four or six. A quantitative variant is actually a special type of structural variant. Still, it allows for a more compact description of variety in the number of constitutive components that would otherwise be much larger or even infinitely large (in the case of open construction kits as defined in Subsection 2.3.2). In the context of modular product families, there could be four or six of the - admittedly small - module ‘fastener’ in the modular product family. The module ‘fastener’ would thus constitute a quantitative variant.

The three types of variety are not orthogonal to each other. This implies that the modular product family can be represented using different combinations of the three types of variety. Due to this and in order to keep the framework for modular product families simple, the component and the structural variant are merged. Both belong to the class of taxonomy relations. A taxonomy is a hierarchical classification of objects. It is characterized by the fact that the subordinate object is more detailed than its superordinate object, i.e. it entails all the properties of the superordinate object plus at least one additional property¹⁹³. It may therefore also be described as a kind-of relation. An example of a taxonomy is shown in Figure 4-4. The subordinate objects ‘aircraft’, ‘ship’, and ‘car’ are all kinds of vehicles. Each of them has at least one additional property distinguishing it from a ‘vehicle’. ‘Aircraft’ for instance has the additional property that it can fly.

Like the product structure of any product or product family, the framework for modular product families also needs part-of relationships in addition to the above-described taxonomy. This type of relation is termed partonomy here. It is required to describe the decomposition of a product

193. [Puls, 2003], p. 40.

into its building blocks. Unlike the taxonomy relation, the partonomy relation occurs in single products as well. The product structure of a single product described in Section 2.3 is a pure partonomy. The partonomy relation is the decomposition of a superordinate object into constitutive subordinate objects¹⁹⁴. A ‘car’ as shown in Figure 4-4 can be decomposed into ‘powertrain’, ‘body’, and ‘interior’.

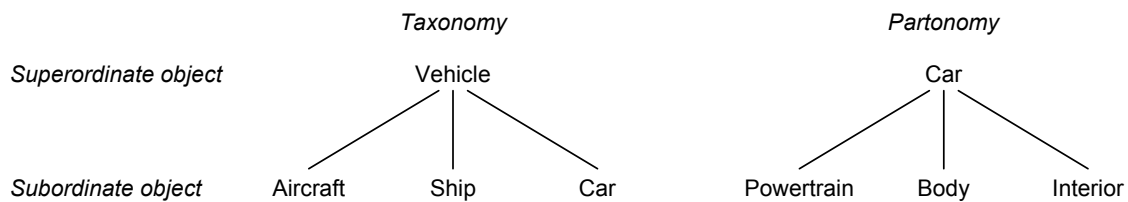

Figure 4-4: Taxonomy and partonomy

So far, the concepts of taxonomy, partonomy, and quantitative variants have been described. These three concepts are sufficient to model a modular product family. In order to complete the framework for modular product families, a visual representation of these concepts is still needed. This is realized using the unified modeling language as described in the following.

The graphical notation here is from the diagrams of the Unified Modeling Language 2.0 (UML)¹⁹⁵. While UML was originally developed to conceive software, it has found its way into numerous other applications such as the modeling of business processes and systems. UML is probably the most widely-used modeling language and many people are familiar with its notation. That is why UML is used here. There are thirteen types of diagrams within UML that are categorized into structure diagrams and behavior diagrams. Structure diagrams are used for modeling the structure of a system, while behavior diagrams are used to model what is happening within a system. Class diagrams, which belong to the group of structure diagrams, are used for the framework for modular product families.

A *class* in the sense of UML is a category of entities that share some structural and behavioral properties. ‘Vehicle’ in Figure 4-4 could, for instance, be a class. An *instance* defines a specific object, e.g. a specific aircraft. In the framework for modular product families, both classes and instances are applied. A class is a category of modules, module variants, or lower level components that has one or several instances. An instance is a specific module, module variant,

194. [Puls, 2003], p. 42.

195. [Oestereich, 2005], pp. 267-290.

or lower level component. The characteristic of an instance is that it does not incorporate variety, i.e. there may not be taxonomy relationships below an instance. Any instance can therefore be described by a standard BOM like the one shown in Figure 2-9. The framework for modular product families stops at the level of instances. The left two symbols for class and instance in Figure 4-5 are used as building blocks for modeling modules, module variants, and lower level components within the framework for modular product families.

There are several types of relationships between classes in UML. Two of these are used for the framework for modular product families. The *decomposition* within UML is used to describe that a class or instance can be decomposed into certain lower classes or instances. The lower classes or instances cannot exist without the superordinate class. The diamond in Figure 4-5 indicates the superordinate class. The composition is generally complemented with multiplicity indicators¹⁹⁶. The number next to the line indicates the number of times that a subclass may be included in its subordinate class. The composition is equivalent to the partonomy relation. The multiplicity indicators are used to represent quantitative variants. Using the building blocks in Figure 4-5, one can model a product family within the framework for modular product families. An example for this is given in the next subsection.

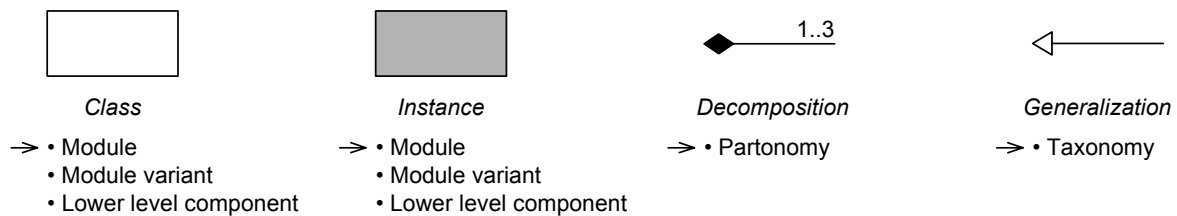

Figure 4-5: Building blocks of framework for modular product families

A *generalization* relates classes to classes or instances. It is depicted using the arrow shown in Figure 4-5. The class that the arrow is pointing to is the more general class whose properties are adopted by the lower class or instance. The generalization within UML is thus the same as a taxonomy. Multiplicity indicators are not needed for the generalization within the framework for modular product families because there is always a one-to-one correspondence between the upper class and the lower classes or instances.

196. [Ambler, 2005], p. 63.

4.2.2 Illustrative Example

In the following, the framework for modular product families is applied to an exemplary family of concrete mixers.

The manufacturer of concrete mixers faces a variety of different customer demands. These differ primarily in terms of mixing capacity and mode of transportation. Some customers would like to have the possibility to transport the concrete mixer as a trailer using a truck. A modular product family is applied to realize these various customer demands while minimizing cost. Some examples of end products within this modular product family are shown in Figure 4-6.



Figure 4-6: Modular product family of concrete mixers

The modular product family is made up of modules and module variants that can be combined to create customized end products. The product structure in the framework for modular product family is shown in Figure 4-7. The modular product family consists of three modules, i.e. ‘engine’, ‘drum’, and ‘chassis’. Each of these modules has to be included exactly one time in any concrete mixer. In order to account for the variety of customer demands in terms of mixing capacity, three module variants of the drum are offered. The capacity of these module variants ranges from 180 over 210 to 320 liters. The different capacities require different engines. That is why two module variants of the combustion engine are offered with power ratings of 0.75 and 1.5 kW. The chassis module can be delivered either as a standard chassis or as a reinforced chassis for higher capacities. The reinforced chassis can be optionally equipped with a drawbar for transportation. ‘0’ stands for no drawbar and ‘1’ stands for equipped with a drawbar.

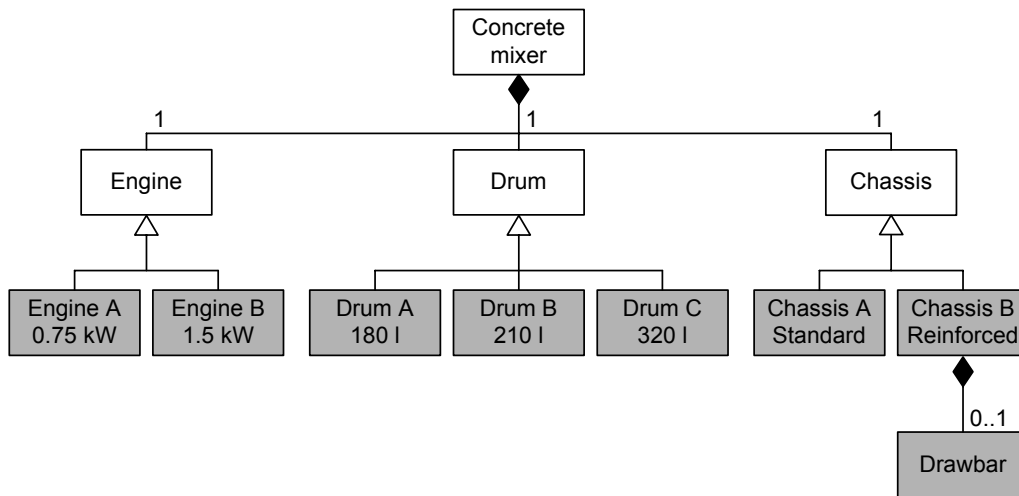

Figure 4-7: Framework applied to family of concrete mixers

The framework for modular families such as in Figure 4-7 represents the current state of a modular product family in terms of its product structure. It is used in the compatibility screen of the variant management funnel to check where a concept for a new module or module variant fits into the product structure. This determines the module sheets that are relevant in the next step, i.e. the interfaces that the new module or module variant will have to satisfy.

4.2.3 Implementation

The framework for modular product families is a representation of the product structure of the modular product family. In many companies, there are different views of the product structure, e.g. engineering, manufacturing, or marketing BOM. Still, from the point of view of the framework for modular product families, one has to determine a single primary product structure of the modular product family. If one of the published methods for conceiving modular product families such as MFD has been applied, then the primary product structure has already been determined as it is one of the outcomes of these methods. If this is not the case, one has to catch up on this task. Decision makers in the company need to decide for one particular view or create a consolidated view through discussions. Once this has been established, the following sources of information can be used to build up the framework for modular product families.

- *Bills of materials (BOMs)*: The BOMs for a modular product family can be found in the product lifecycle management (PLM) system, the enterprise resource planning (ERP) system, or computer-aided design (CAD) software. In either case, the BOMs

can be stored either as standard single product BOMs or generic BOMs¹⁹⁷ with consideration of variety. In the first case, it is only possible to guess on the structure of modules and module variants based on the similarity of BOMs. In the second case, the structure of modules and module variants can be constructed as variety is shown explicitly in the generic BOM.

- *Configurators*: Configurators are used to derive a customer-specific BOM from the generic BOM based on particular customer demands. They are based on configuration rules, graphs, or matrices. The information on the structure of modules and module variants and how they may be combined can generally be extracted from configurators. The configurator may also be part of the ERP system.
- *Sales documentation*: Companies generally provide product catalogs to the customer containing all variants available to the customer. The information required for the framework for modular product families can sometimes be extracted from these catalogs. Product catalogs are, however, written from a customer perspective and therefore do not contain modules and module variants that are not selected by the customer. If the company has no configurator, sales questionnaires and configuration sheets are very often in place to guide the sales process. These documents can also be used to obtain information for the framework for modular product families.
- *Employees*: Employees who have been working with the technical aspects of various parts of the modular product family over an extended period of time generally have good knowledge of the structure of modules and module variants. These people can be interviewed to progressively build up the framework for modular product families with them.

The first three sources of information are easily accessible, while information from employees is the most in-depth and up-to-date. That is why it is suggested to combine BOMs, configurators, and sales documentation with the knowledge of employees. In implementing the framework for modular product families, one should first make a draft using information from the first three sources. In the second step, one should improve the framework by means of interviews with employees.

197. In this context, a generic BOM is identical to a generic product structure, see Subsection 3.2.2.

4.3 Module Sheets

The interfaces between the modules of a modular product family are one of the two key properties of a modular product family. Support is needed to help safeguard this key property. This is the role of module sheets, which can be applied to capture the interfaces of every module within the modular product family. In variant management of modular product families, module sheets are used in the compatibility screen to rapidly check whether a concept for a new module or module variant is compatible with the existing modular product family in terms of interfaces. Module sheets are thus part of Step 1.2 in Figure 4-2 and are meant to fulfill Requirements 2 and 3 as described in Section 3.1. The information that should be part of a module sheet is described in the following.

4.3.1 Tool

Information on interfaces within a modular product family, if at all existing, is generally dispersed among different documents such as technical drawings and circuit layouts. This makes it very cumbersome for a decision maker to check whether a concept complies with the modular product family's interfaces. This issue is to be solved by centralizing information regarding interfaces on module sheets.

Module sheets contain the most relevant information necessary for safeguarding interfaces. Module sheets are thus similar to interface control documents, which are used in systems engineering¹⁹⁸. They also serve as point of entry by providing links to documents with further relevant information. A module sheet is prepared for every module within the product family. If there are module variants to a module, there should still be only one module sheet. The underlying thinking behind this is that a module variant should adopt as many properties as possible, especially interfaces, from its superordinate module so as to minimize variety. This is in line with the philosophy of UML described in Subsection 4.2.1. An example of a module sheet is shown in Figure 4-8. Module sheets are structured into three distinctive sections, which are discussed in the following, namely module characterization, module interfaces, and module configuration.

198. [Blyler, 2004], p. 33, [Blanchard, 1998], p. 224.

Module characterization is the first section of a module sheet and is meant to give an overview of the module with respect to aspects such as structure, usage, and future evolution. If a particular piece of information is already laid down elsewhere, e.g. in the scope of an existing approach to variant management, it is sufficient to just link the respective information so that no redundant information is created. The aspects that are part of the first section of a module sheet are discussed in the following.

- *Photo or drawing*: A visual representation of the module facilitates recognition. That is why a photo or drawing of the module is given.
- *Relevant documents*: There generally are documents such as specifications and assembly drawings providing introductory information to a module. These documents are linked here.
- *Variants and options*: As described above, there should be only one module sheet even if there are several module variants. That is why variants need to be described within the module sheets. This is done using the taxonomy and paronomy relations introduced in Subsection 4.2.1. Moreover, there may be options such as additional parts or assemblies that may be selected by the customer. These are also shown in the module sheet using the paronomy relation. The objective is, however, not to describe the entire product structure of the module. The structure should only be shown down to the level where there is no more variety in the components. In other words, there should be no taxonomy relations nor quantitative variants. The product structure below this level can be represented using standard bills of material such as the example in Section 2.3.
- *Usage list*: As one attempts to safeguard interfaces by discarding incompatible concepts for new modules and module variants, it is important to know the end products that the module is used in. This is because these end products can imply specific constraints that have an impact on interfaces. That is why a usage list is provided here. All of the end products that the respective module can potentially be used in are listed. In some modular product families, there are no defined end products, e.g. because the product family is completely configurable. In this case, it is not necessary to give a usage list.

- *Future evolution*: If there are changes envisaged to the module that have an effect on the interfaces, e.g. in the form of a product roadmap, these changes are listed here. Using this information, the decision maker can check whether a concept is also compatible in terms of interfaces with future versions of the module.

The second section of the module sheets is dedicated to *module interfaces* and is therefore very important. It entails the following aspects.

- *Interface row*: An example of a DSM has been given in Figure 3-7. One row of a DSM is used here to characterize the interfaces of the respective module with other modules. All of the modules within the product family are listed column by column. Symbols in the columns indicate interfaces between the module described in the module sheet and the module in the respective column. It is distinguished between the four types of interfaces identified by PIMMLER & EPPINGER¹⁹⁹. These are geometry (G), energy (E), signal (S), and material (M). Geometry applies to physical points of contact or proximity between two modules. Energy relates to all types of energy, such as electrical, electromagnetic, mechanical, or pneumatic energy. Signal refers to all information exchanged between modules for the purpose of control and for informing on the system condition. Material applies to all types of physical matter that is exchanged between modules²⁰⁰. If interfaces differ for different module variants, one may also use a separate row for each module variant. Although this is not desirable from the point of view of modularity, variety in a module's interfaces can make these interfaces cheaper to manufacture. It may also be advisable to add a column for interfaces with the environment.
- *Interface explanations*: In the instance of a very simple product family, the classification of all interfaces into four categories may be sufficient for the decision maker to understand and safeguard interfaces. In the case of more complex product families, additional information is needed. All of the interfaces in the interface row are therefore given an identification number. Explanations regarding the single interfaces are ordered by this number and given here.

199. [Pimmler and Eppinger, 1994], p. 4.

200. For an extensive listing and classification of material, signal, and energy interfaces, see [Hirtz et al., 2002], pp. 72, 73.

The last section of a module sheet is on *module configuration*. Module configuration refers to the question of which modules or module variants must or must not be combined. This is an important aspect for the decision maker to know because one only needs to check the interfaces between modules that may actually be combined.

- *Restrictions*: All restrictions with respect to configuration are listed here. Concretely, this means that all combinations of modules that are either mandatory or not allowed are listed. In order to facilitate immediate understanding, simple sentences rather than a complicated standardized format are used to express restrictions.

In addition to the above-described three sections, the module sheet also requires *metadata* covering the aspects that are part of formal product documentation. This may include, for instance, document number, revision history, and employee in charge. If possible, module sheets should be integrated into the company's document or product data management system so that this information is generated automatically.

4.3.2 Illustrative Example

An illustrative example of a module sheet for the 'engine' module within the product family of concrete mixers is shown in Figure 4-8. The example includes all of the aspects described in the last subsection.

The module sheets starts with *metadata* including the module's name, document number, and revision history.

The *module characterization* section starts with a picture of the module. Relevant documents are listed next. Since the module sheets should be administered in the company's document management system, direct links to the documents are given. The variants of the engine module are listed in the same notation as the framework for modular product families. There are no end product defined for the product family of concrete mixers. That is why the usage list is empty. A 2 kW module variant of the engine is envisaged in the future. The respective product roadmap is provided as a link.

The decision maker can conclude from the *module interfaces* section that the 'engine' module has an electric interface with the 'drum' module and geometric interfaces with the 'drum' and 'chassis' modules. Explanations on the interfaces with the 'drum' module are also given.

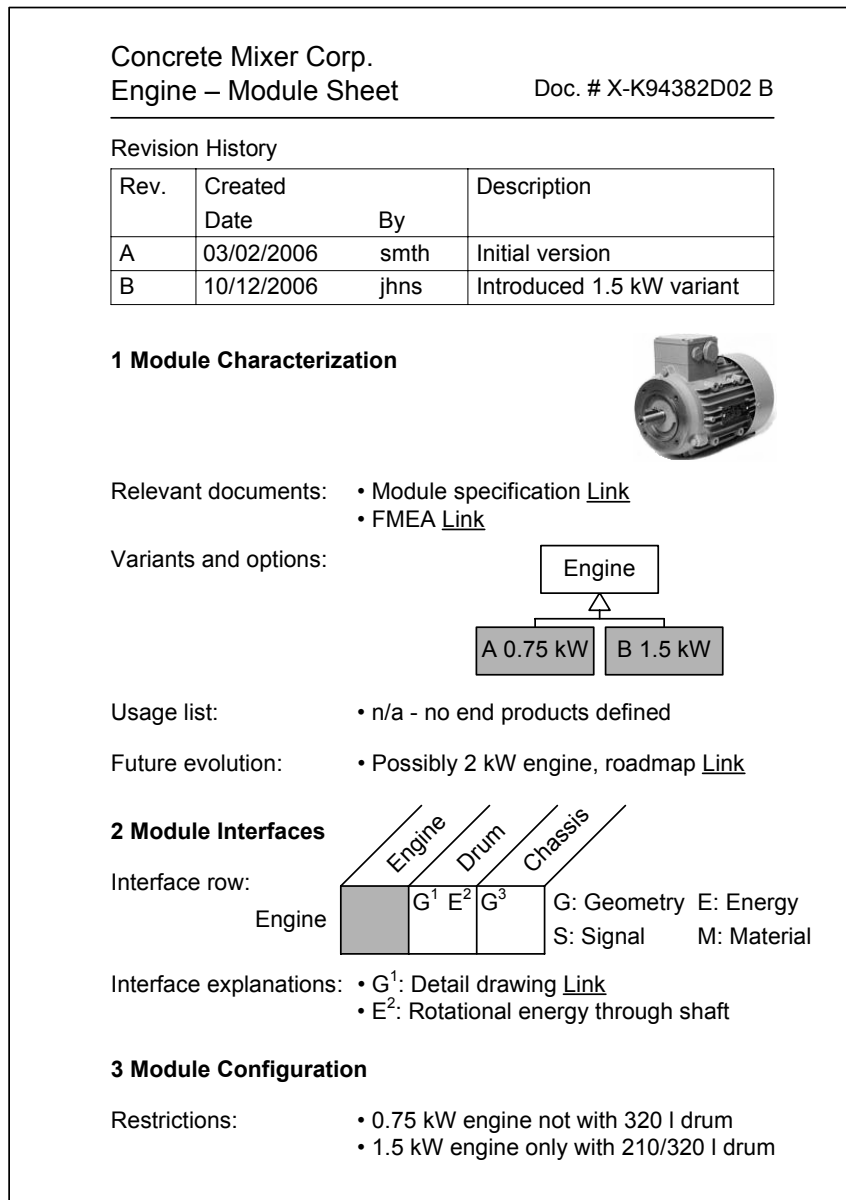

Figure 4-8: Module sheet applied to engine module

Restrictions in combining the ‘engine’ with the ‘drum’ module are listed in the *module configuration* section.

4.3.3 Implementation

Module sheets are a consolidation of knowledge already explicitly or implicitly present in the corporation. The task therefore consists of collecting and compiling information from the following sources.

- *Product specifications*: Product specification documents are the primary source of information to obtain an overview of a module. They can be used to extract information about variants and options, other relevant documents, usage, and future evolution of a module. Besides, product specification should provide information on the module's interfaces.
- *Detail and assembly drawings*: Detail and assembly drawings contain information on geometric and potentially also on material interfaces.
- *Circuit diagrams*: These can be used to obtain information on electrical and signal interfaces.
- *Software code*: Software code is the primary source of information for signal interfaces.
- *Employees*: Employees who have a good knowledge of the entire modular product family should be consulted to both guide to relevant documents and provide additional information for filling out the three sections of module sheets.

As with the framework for modular product families, it is suggested that one first makes drafts of module sheets using information from product specifications, detail and assembly drawings, circuit diagrams, and software code. In the next step, one should go over these drafts with one or several employees who are familiar with the entire product family. The module sheets are corrected and augmented and brought into their final form.

4.4 Probabilistic Evaluation and Improvement

Probabilistic evaluation and improvement is applied to modules and module variants in the stakeholder screen. The tool realizes Steps 2.1 and 2.2 in Figure 4-2 and is meant to fulfill Requirements 4 to 8 described in Section 3.1.

4.4.1 Tool

Probabilistic evaluation and improvement is significantly more complex than both the framework for modular product families and module sheets. That is why in this subsection, an overview of the tool is provided first. The single steps that are part of evaluating and improving a concept are explained next. Finally, it is shown how the entire process is supported by an Excel-based VBA application.

An overview of probabilistic evaluation and improvement is shown in Figure 4-9. The process starts with a concept for a new module or module variant fulfilling the requirements imposed by the compatibility screen. Following the terminology of HUBKA & EDER²⁰¹, a concept is characterized by a set of *properties*. This could for example be the number of parts of the proposed new module. A property can take different values within a value scale. An example of a value scale would be less than 100 parts, between 100 and 200 parts, and more than 200 parts. The *effects* of the concept, e.g. assembly time, will be different depending on these values. Effects are measured in terms of *decision criteria* that are relevant from the point of view of the variant strategy. Examples of decision criteria that can be used to measure effects are cash flow or amount of work. The outcome of this step is a large number of effects described by probability distributions of decision criteria. Monte Carlo simulation is then applied to calculate the overall probability distribution for each decision criterion. Finally, each distribution is condensed into two *key indicators* serving as decision basis.

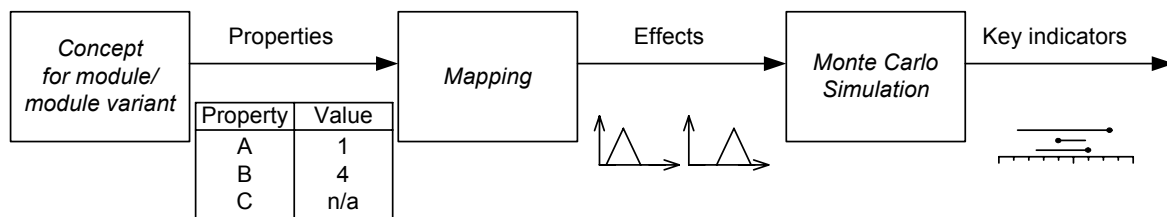

Figure 4-9: Overview of probabilistic evaluation and improvement

Using the key indicators, the decision maker can evaluate and rank different concepts. The decision maker then chooses the concept that should be implemented. The respective concept can be improved by striving to alter the values of properties in the probabilistic model, e.g. by reducing the number of parts. One can learn about the relative benefit in terms of the decision criteria just by observing the resulting changes in the key indicators. A deliberate decision on whether or not to alter a property's value can be taken through comparison of the relative benefit to the cost required to alter the value. This is a sensitivity analysis and the concept can thus be improved in terms of its expected performance and risk. The process from properties, over effects, to key indicators is described in detail in the following.

201. [Hubka and Eder, 1996], pp. 108-114.

Properties

Properties are defined here as features of a concept having an impact on effects. Properties have an assigned value scale containing concrete values or value ranges but also ‘unknown’ if the value is unknown to the decision maker at the time of decision. An example of a property is the number of parts of a new module or module variant. This property has an impact on the assembly time of the respective module. Properties may be directly controllable by the decision maker, indirectly controllable, or not controllable at all.

This is in fact the primary difference as compared to the utility-based optimization methods discussed in Subsection 3.2.3. Using utility-based optimization methods, a strict difference is made between control and disturbance variables, which both determine the decision attributes. The control variables, decision variables, and their relationship with the decision attributes are modeled and change with every new decision at hand. As a result, a new optimization model is required for every new decision, which makes them very elaborate to apply.

This is different with the tool proposed here as it is based on properties, not control and disturbance variables. Every property is assigned a value scale. The decision maker characterizes a concept by selecting the appropriate value, value range, or ‘unknown’ for each single property. The result is a property/value table as shown in Figure 4-9. The complex relationships that determine decision attributes are not modeled explicitly. Instead, the decision maker selects the values of properties. Since the complex and changing relationships are not modeled, there is no need to prepare a new optimization model for every new decision. Using properties, the same probabilistic simulation model can be reused for a wide variety of module and module variant concepts. The only task for the decision maker is to select the appropriate values.

Effects

Effects are incidents in the broadest sense that will take place if the concept for the new module or module variant is actually carried out. They are measured in terms of decision criteria such as cash flow. Effects occur all along the innovation process. In Subsection 2.1.2, the innovation process has been divided into three main phases, namely product planning, strict development, and realization. Different stakeholders in the corporation are involved in different phases of the innovation process. Strict development is the classic engineering design process such as in

PAHL & BEITZ²⁰². It is the primary field of activity of R&D. Realization includes production, distribution and sale, as well as use. It is dominated by manufacturing and sales. In variant management of modular product families in the market phase, the decision maker is at the end of product planning where concepts are evaluated and improved. In evaluating and improving concepts, one needs to consider effects that occur in the downstream phases of strict development and realization. As shown in Figure 4-10, effects in strict development and effects in realization are different in terms of the number of occurrences. Making technical drawings, which is part of strict development, occurs only once, while assembly, which is part of realization, occurs with every module sold.

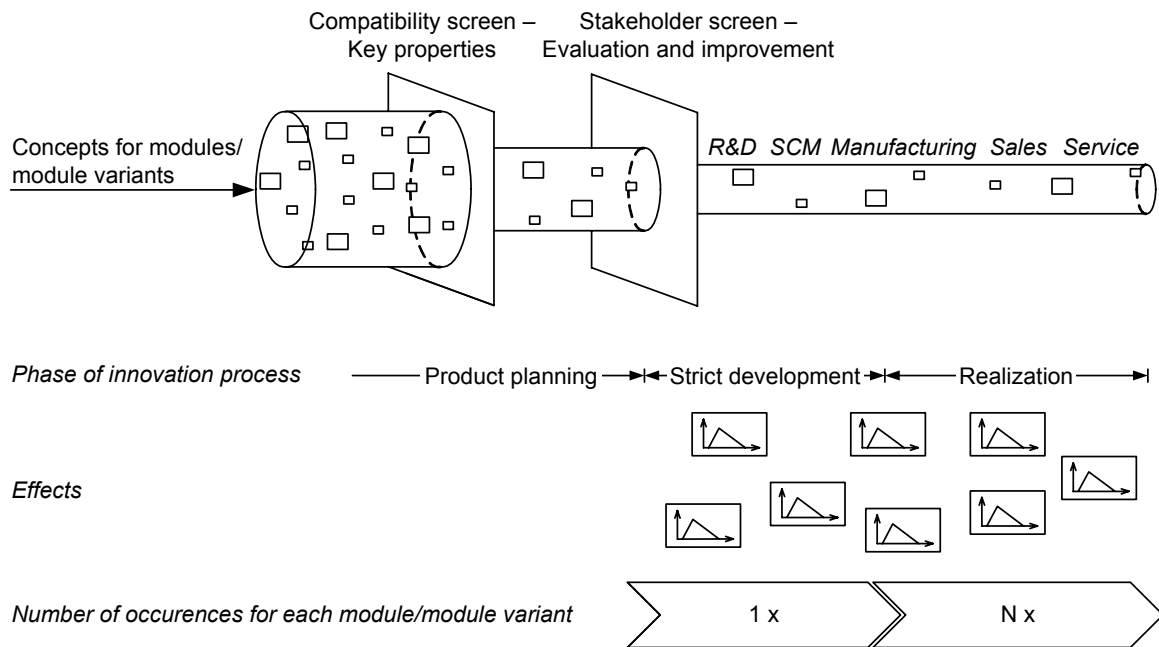

Figure 4-10: Effects within the innovation process

Since the development of a new module or module variant is a one-time activity, effects in this phase of the innovation process occur only once. Realization of a module or module variant, however, takes place every time an order is placed by a customer. That is why effects in this phase may occur multiple times. This number is uncertain as one does not know in advance how often a module or module variant will be sold. It is modeled as a probability distribution. The higher the planned sales volume of a module and the higher the relative manufacturing cost of a module, the more the center of attention will shift from effects in strict development to effects in realization. This is for instance the case in the automotive industry. Under these

202. [Pahl and Beitz, 1996].

circumstances, it may be feasible to focus on effects in realization. In industries where a large fraction of costs occur in development, however, such as plant engineering, it is might be necessary to focus more on strict development.

As emphasized in Subsection 3.1.2, uncertainty is an intrinsic property of decisions in variant management of modular product families in the market phase. Three types of uncertainty in effects are considered in probabilistic evaluation and improvement.

- *Uncertainty of magnitude*: Effects are measured in terms of decision criteria, e.g. cost. The exact magnitude of these effects is generally unknown, e.g. at the time of evaluation and improvement, it is not known exactly how expensive it will be to purchase a particular part.
- *Uncertainty of occurrence*: The occurrence of some effects is uncertain at the time of evaluation and improvement. In other words, it is uncertain whether or not a specific effect will actually take place.
- *Uncertainty of origin*: In the case of some effects, the cause-and-effect relationship remains unclear. This implies that an effect occurs without one being able to tell which module or module variant caused it. All that one can say is that there is a group of modules or module variants that either commonly caused the effect or from which an unknown specific one caused the effect.

Based on the above types of uncertainty, it is distinguished between the three types of effects shown in Figure 4-11. First, there are *direct effects*, which are in the upper left quadrant in Figure 4-11. Direct effects only imply uncertainty of magnitude. The occurrence of this type of effect is certain and it is clear which new module or module variant caused the effect. An example of a direct effect in variant management of modular product families in the market phase is the preparation of product documentation measured in man-days. Occurrence of this effect is certain and it can be traced back to a single new module or module variant that caused it. The exact magnitude of the effect is, however, uncertain. Another example of direct effects are sales. One can generally be sure that some quantity of a module or module variant will be sold. The exact magnitude of sales in terms of cash flow is, however, uncertain.

The second type of effects are *side effects*, which comprise both uncertainty of magnitude and uncertainty of occurrence. The effect can, however, be clearly traced back to a single new module or module variant. A side effect might for instance be to evaluate new suppliers. In

many instances, it cannot be said at the time of concept evaluation and improvement whether a new supplier will be needed. Besides, the exact costs and man-days of this effect are uncertain. Still, it is possible to say which new module or module variant caused the effect of supplier evaluation.

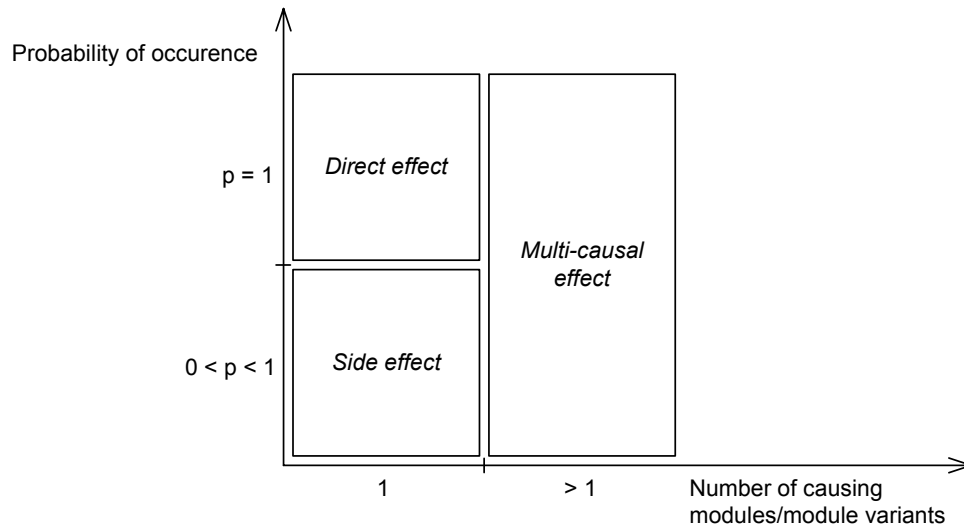

Figure 4-11: Taxonomy of effects

Multi-causal effects, which are the third type of effects, include all types of uncertainty, i.e. uncertainty of magnitude, uncertainty of occurrence, and uncertainty of origin. In the case of multi-causal effects, it is unclear which new module or module variant actually caused an effect to occur. An example of a multi-causal effect is the increase in administration effort that comes with new modules and module variants. This effect can be observed for instance in product data management, supply chain management, and process engineering. Multi-causal effects are generally not as evident as direct or side effect and some are relatively minor. Still, the sum of the multi-causal effects can be very profound.

It is now described how to model these three types of effects mathematically. *Direct effects* only involve uncertainty of magnitude. They can therefore be described by a single random variable X defined as the magnitude of a decision criterion for an effect. The random variable X has a probability density function $f(x)$ ²⁰³. The triangular distribution is used here. The reason for using the triangular distribution in the scope of probabilistic evaluation and improvement is that the triangular distribution is simple to understand for a decision maker in a company, which is

203. The fundamentals of probability theory that are required for understanding are not discussed here. It is referred to probability theory textbooks, such as [Jondral and Wiesler, 2000] and [Gut, 2005].

one of the requirements outlined in Subsection 3.1.2. It is completely described by only three simple variables shown in Figure 4-12, namely the lower bound a , upper bound b , and mode c .

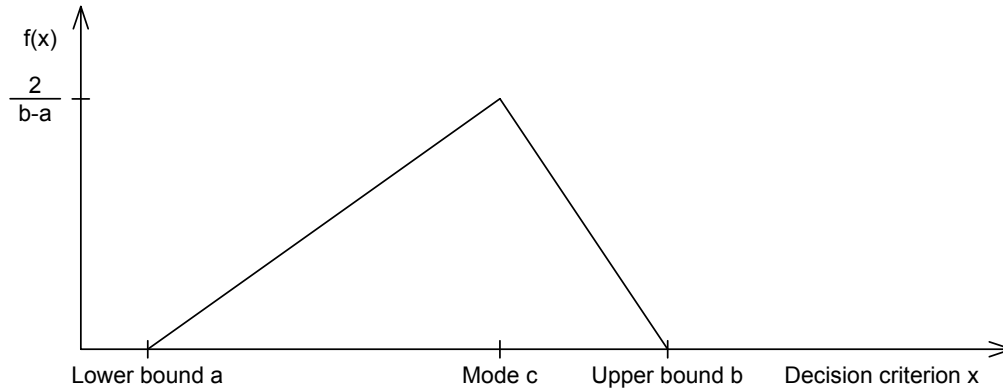

Figure 4-12: Probability density function of triangular distribution

Unlike a normal distribution requiring knowledge of the standard deviation, the triangular distribution can be applied even when information is scarce. Moreover, the probability distribution function $f(x)$ of a triangular distribution is bounded, which is a more suitable assumption than unboundedness for most applications. Finally, the triangular distribution is considered a good approximation of a normal distribution, especially when information is scarce, without having some of its undesired properties (required symmetry and unboundedness). Mathematically, a *direct effect* is therefore completely described by a random variable X with the following probability density function of a triangular distribution.

$$f(x) = \begin{cases} \frac{2(x-a)}{(b-a)(c-a)} & \text{if } a \leq x \leq c \\ \frac{2(b-x)}{(b-a)(b-c)} & \text{if } c < x \leq b \end{cases} \quad (4-1)$$

In addition to uncertainty of magnitude, *side effects* also involve uncertainty of occurrence. Uncertainty of occurrence is described by the random variable Y . The random variable Y is discrete because it can only be zero or one. It is described by the probability mass function in Equation 4-2 where p is the probability of occurrence.

$$p(y) = \begin{cases} p & \text{if } y = 1 \\ 1 - p & \text{if } y = 0 \\ 0 & \text{else} \end{cases} \quad (4-2)$$

Since side effects involve both uncertainty of magnitude and uncertainty of occurrence, the random variable W describing a side effect is a function of the above-described random variables X and Y .

$$W = Y \cdot X \quad (4-3)$$

Multi-causal effects involve uncertainty of magnitude, uncertainty of origin as well as uncertainty of origin. That is why the conversion rate k is introduced. The conversion rate k is used to allocate a multi-causal effect among the modules and module variants that have or might have caused it. The random variable Z , which describes a multi-causal effect is given in Equation 4-4.

$$Z = k \cdot Y \cdot X \quad (4-4)$$

So far, it has been described how one can model direct, side, and multi-causal effects. The probability density function is used for modeling uncertainty of magnitude, the probability of occurrence for uncertainty of occurrence, and the conversion rate for uncertainty of origin. These three pieces of information will look different depending on the particular concept that is evaluated or improved. This is where the above-described properties are applied. Properties have been defined as features of a concept that have an impact on effects. A property may take several values. Depending on the value of the property, probability distribution, probability of occurrence, and conversion rate of the effect may look different. An example of the impact of the property of number of parts on the direct effect of assembly time is shown in Figure 4-13. In other words, there are different variants of the same effect as a function of the values of properties.

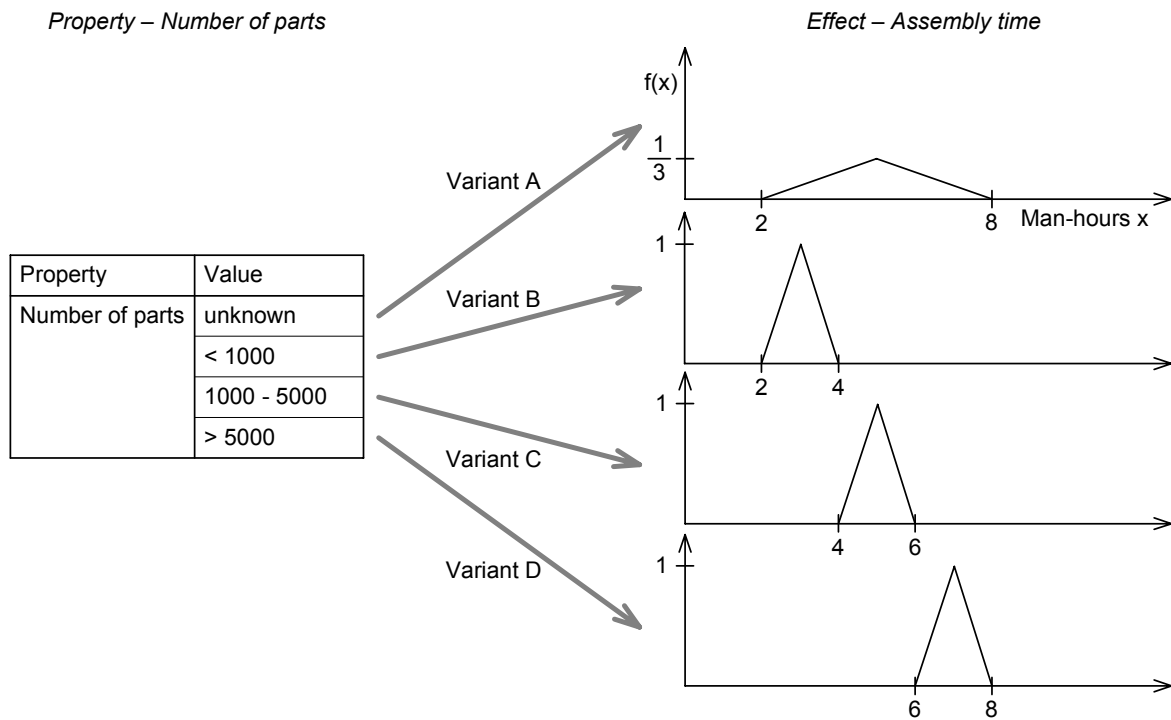

Figure 4-13: Different variants of same direct effect determined by property

Using property/value tables such as in the left of Figure 4-13 as well as associated probability distributions, probabilities of occurrence, and conversion rates, one can model distinct effects as a function of the properties of a concept for a new module or module variant. This is used in the following to evaluate and improve concepts. The property of number of parts may take different values. It may be ‘unknown’, smaller than 1000 parts, between 1000 and 5000 parts, or greater than 5000 parts. In each case, the probability distribution of assembly time will be different. If the number of parts is larger, then the expected assembly time will be longer. Similarly, if nothing is known about the number of parts, the spread of the probability distribution will be larger and uncertainty will be greater. Since assembly time is a direct effect in this context, the number of parts only has an impact on the probability distribution of assembly time. In the case of side effects, different values of a property can also result in different probabilities of occurrence. Similarly, for multi-causal effects, a property can have an impact on both probability of occurrence and conversion rate.

Key Indicators

Once all effects have been determined, there are probability distributions, probabilities of occurrence, and conversion rates for all effects. If the realization phase is considered, there is also a probability distribution for the number of times that the evaluated module or module variant will be sold. The task consist of aggregating the single probability distributions into a single probability distribution for every decision criterion and condensing the resulting distributions into the expected value and the conditional value-at-risk, the so-called key indicators. This is described in the following.

One needs to calculate the overall probability distributions for each decision criterion that has been identified as being relevant from the point of view of variant strategy, e.g. cash flow or amount of work. It is thus necessary to calculate the addition and multiplication of random variables²⁰⁴. This is a highly intricate and time-consuming undertaking and can only be done using computer algebra systems, which the decision maker generally does not have at hand nor knows how to use them. An analytic solution therefore conflicts with the requirement of limiting resources required. That is why Monte Carlo simulation is used here to find an approximate solution by solving the problem numerically. Monte Carlo simulation can be carried out with widely available and broadly understood software such as Excel. Monte Carlo simulation is also very time-efficient. Finally, it is very flexible as the simulation model can be augmented with additional effects without major modifications.

The idea behind Monte Carlo simulation²⁰⁵ is to solve complex problems numerically. The difference between analytic solution and Monte Carlo simulation is illustrated in Figure 4-14. In analytic solution, which is shown in the upper half of Figure 4-14, the overall probability distribution is calculated directly from the individual probability distributions through convolution integrals.

204. [Jondral and Wiesler, 2000], pp. 114-117.

205. [Dubi, 2000], pp. 71-109.

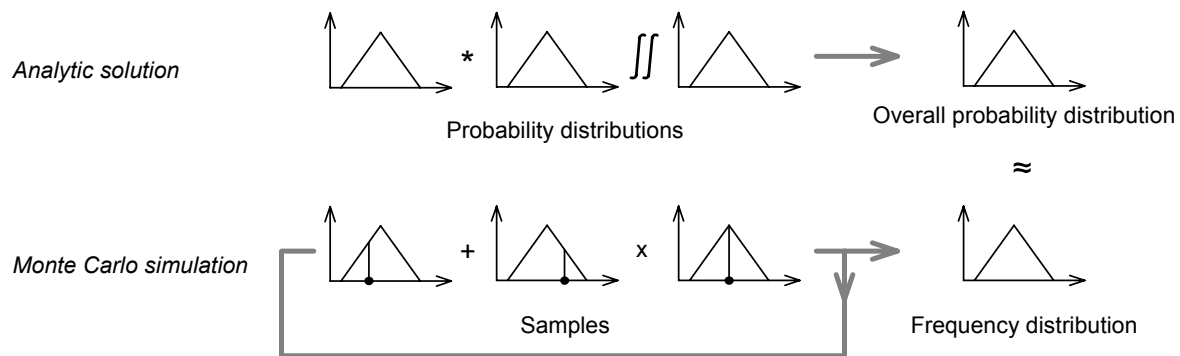

Figure 4-14: Comparison of analytic solution with Monte Carlo simulation

In Monte Carlo simulation, which is shown in the lower half of Figure 4-14, one generates random samples according to the individual probability distributions. Since one now only deals with single samples instead of entire probability distributions, the samples can be treated as deterministic values. The random samples are therefore simply added and multiplied. As indicated by the loop in Figure 4-14, this process is repeated many times and the resulting frequency distribution of outcomes is calculated. As one increases the number of repetitions, the frequency distribution obtained through Monte Carlo simulation converges towards the overall probability distribution obtained analytically²⁰⁶.

Complex calculations such as convolution integrals can thus be broken down into simple addition and multiplication operations. That is why one of the primary strengths of Monte Carlo simulation is its effectiveness, especially as one simulates complex systems²⁰⁷. In this context, Monte Carlo simulation is applied to calculate the overall frequency distribution for each decision criterion from the individual effects. This frequency distribution converges towards the overall probability distribution for each decision criterion that one would obtain analytically. As shown in Figure 4-15, a random number generator is used to generate samples for effects in strict development and realization as well as samples for the number of modules and module variants that will be sold. The samples of the effects in strict development are simply added up. Effects in realization are added up and multiplied with the sample for the number of modules to be sold. Subsequently, all of the results are added up. This is repeated many times until the frequency distribution is sufficiently close to the overall probability distribution.

206. This is supported by the central limit theorem, see [Rice, 1995], pp. 166-173.

207. [Dubi, 2000], p. 71.

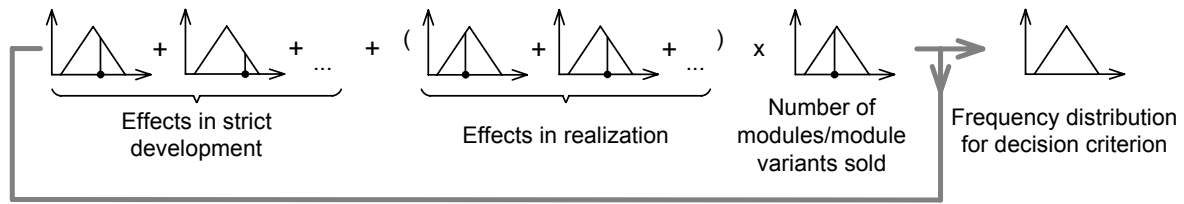

Figure 4-15: Calculation of overall frequency distribution

Once Monte Carlo simulation is complete, the decision maker has an approximation of the probability distribution for each decision criterion. Still, a probability distribution is too rich in information to serve as a basis for evaluating and improving concepts. A decision maker will most likely only be interested in two things. First, the decision maker will want to have a measure of how the concept will most likely perform in terms of the decision criteria. Second, the decision maker will want a measure of the risk associated with a concept in terms of the decision criteria. Risk in this context is the likelihood of the actual outcome deviating from the expected outcome in a negative way. That is why the following two key indicators are calculated from the frequency distribution of each decision criterion.

$E(X)$ is the *expected value*²⁰⁸ of the random variable X for an effect measured in terms of a decision criterion x with the probability density function $f(x)$.

$$E(X) = \int_{-\infty}^{\infty} xf(x)dx \quad (4-5)$$

The expected value corresponds to what the decision maker can most likely expect the concept to perform like in terms of the respective decision criterion. The expected value is what a risk-neutral decision maker would be interested in.

As outlined above, the decision maker will want a measure of the risk associated with a concept. Due to its good mathematical properties²⁰⁹, the *conditional value-at-risk* (CVaR) is a relatively new, but broadly accepted, measure of risk in economics and finance. The CVaR is applied here to the task of concept evaluation and improvement. The CVaR is defined as the conditional expected value under the condition that the decision criterion x is above or below a specific

208. [Jondral and Wiesler, 2000], p. 54.

209. [Koller, 2005], pp. 38-41.

quantile α . In the case of a positive decision criterion x , e.g. cash flow, with the probability density function $f(x)$, the CVaR is calculated as shown in Equation 4-6.

$$\text{CVaR}_{\alpha}(X) = \int_{-\infty}^{q_{\alpha}} xf(x)dx \quad (4-6)$$

In this context, q_{α} is the value of the decision criterion x for which the cumulative distribution function reaches α . For positive decision criteria such as the above-mentioned cash flow, integration is from $-\infty$ to q_{α} . For negative decision criteria, e.g. amount of work, integration is from q_{α} to ∞ . In the literature, $\alpha = 90\%$ is commonly used for negative decision criteria and $\alpha = 10\%$ for positive decision criteria²¹⁰. This is adopted here. The CVaR for a positive decision criterion is shown in the following equation.

$$\text{CVaR}_{10\%}(X) = \int_{-\infty}^{q_{10\%}} xf(x)dx \quad (4-7)$$

Expected value and CVaR are illustrated in Figure 4-16. Due to the fact that the probability density function is symmetric, $E(X)$ is located right in the center of the probability density function. Since $\alpha = 10\%$ has been chosen, $q_{\alpha=10\%}(x)$ is the value of the return x for which the cumulative distribution function reaches $\alpha = 10\%$. The CVaR is the expected value over the area left of $q_{\alpha=10\%}(x)$, i.e. the grey area.

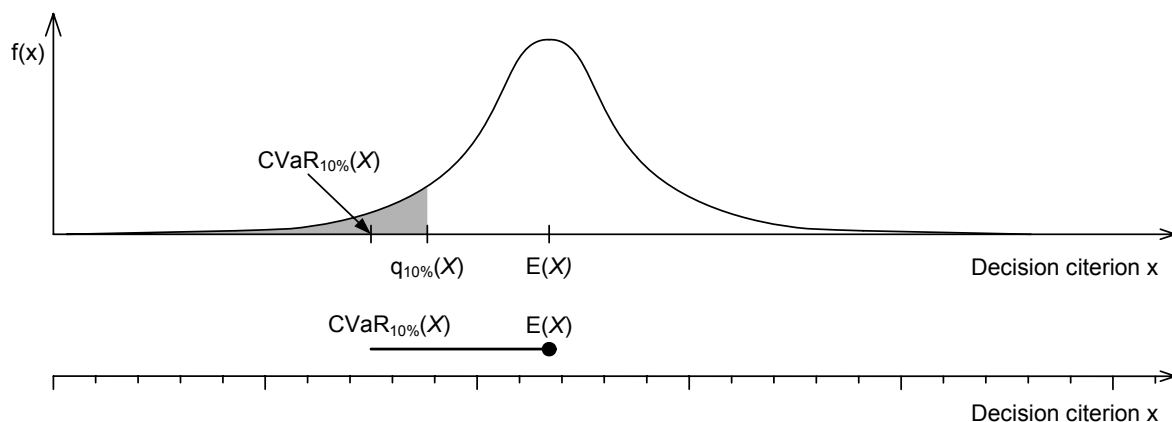

Figure 4-16: Illustration of expected value and CVaR

210. [Rockafellar and Uryasev, 2001], p. 21.

So far, all the steps that are part of evaluating and improving have been discussed in detail. The evaluation of a concept starts with choosing the respective values for all properties that have an impact on the effects of the new module or module variant in the innovation process. Depending on the choice of values, the effects will be different in terms of probability distribution, probability of occurrence, and conversion rate. Monte Carlo simulation is used to calculate the overall frequency distribution for each decision criterion from the individual effects. The frequency distribution for each decision criterion is then condensed into two key indicators. These are the expected value as a measure of what the decision maker can expect the concept to perform like and the CVaR as a measure of the associated risk. The decision maker can evaluate concepts using the key indicators and improve concepts by striving to alter the values of properties.

The process from properties to key indicators is rather intricate. That is why a supporting Excel-based application has been developed. Using this application, the decision maker only needs to choose the values of the properties and have the computer calculate the key indicators.

Excel-Based VBA Application

Due to its wide availability and simplicity, Excel was chosen as a basis for computer support. The structure of the VBA application is rather simple. There are three types of sheets. First, there is the *user interface*, where the user selects values for all of the properties. The user then presses the 'simulate' button to obtain expected value and CVaR with a graphical representation for each decision criterion. Second, there is the *simulation model*, which includes all effects characterized by their probability distribution, probability of occurrence, and conversion rate. This model is provided as a large table. If there are properties that have an impact on the effects, then a separate row is given for each value of the property with the respective probability distribution, probability of occurrence, and conversion rate. Third, the *simulation results* are also recorded as a table with each cell containing the outcome for one simulation and one decision criterion. The expected value and the CVaR are calculated from the simulation results. The interaction between the different Excel sheets is shown in Figure 4-17.

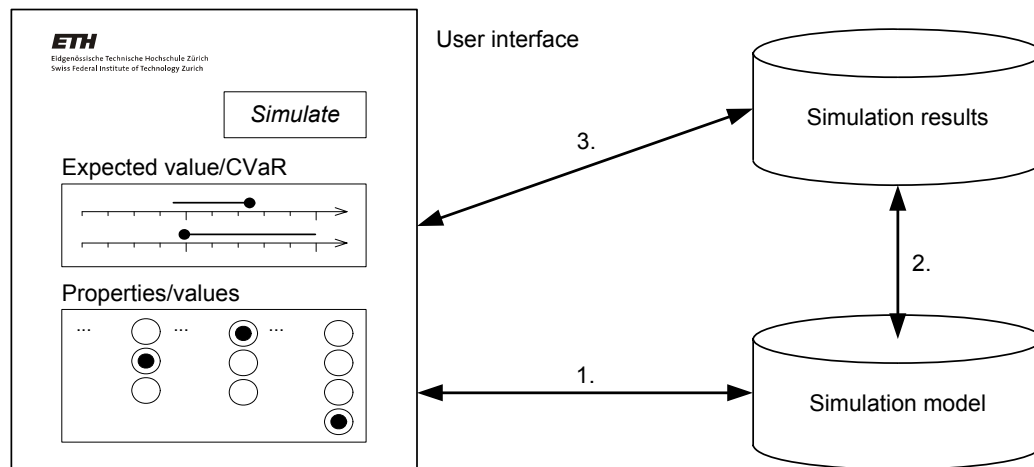

Figure 4-17: Structure of VBA application

The appropriate values for the properties are selected by the decision maker in the user interface and passed on to the simulation model (1.). Monte Carlo simulation is then carried out using the respective probability distributions, probabilities of occurrence, and conversion rates. The results are stored in the sheet for simulation results (2.). Finally, the expected values and CVaRs for all decision criteria are displayed in the user interface (3.). A screenshot of the user interface is shown in Figure 4-18.

In the upper left, the user can select the number of Monte Carlo simulations to be carried out. The higher the number of simulations, the more accurate the results. Computing time, however, also increases with number of simulations. The decision maker characterizes a concept by selecting appropriate values for the properties in the lower part of the user interface. The actual simulation is started by pressing the ‘simulate’ button. Once simulation is complete, the results for the expected value and the CVaR for each decision criterion are displayed graphically in the middle of the user interface. The circle in the diagram represents the expected value, while the length of the line connecting the expected value and the CVaR represents risk. Since properties are listed explicitly, the decision maker can improve the concept by consciously striving to alter values of properties. The benefit from such changes in terms of the decision criteria can be calculated immediately by repeating the simulation with the new values. Finally, the decision maker can obtain a more detailed report of a concept’s performance by pressing the ‘diagrams’ button to obtain the frequency distribution for each decision criterion.

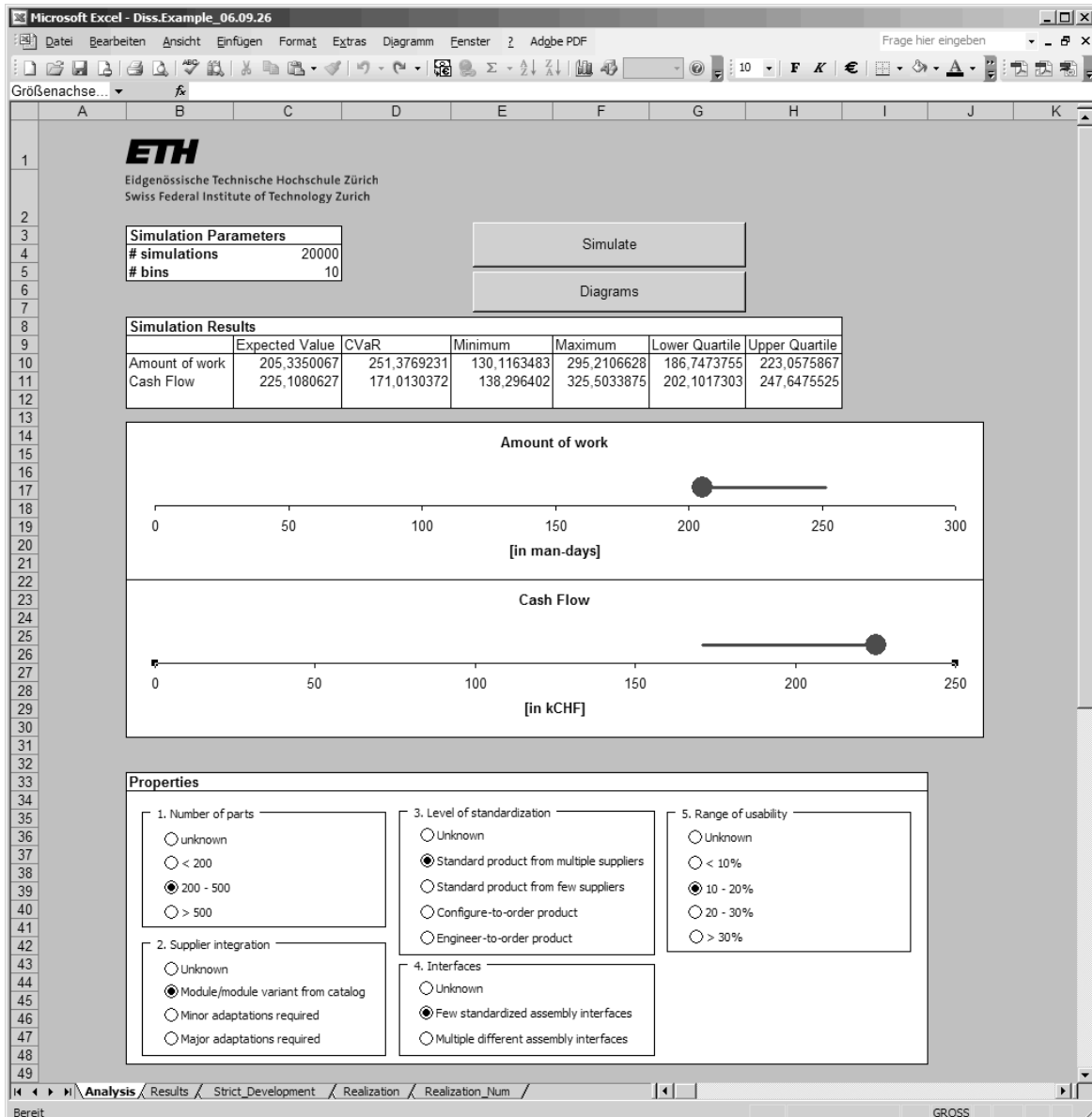

Figure 4-18: Screenshot of user interface

4.4.2 Illustrative Example

The manufacturer of concrete mixers, which was already used for illustrating the framework for modular product families and module sheets, now plans to introduce an electric motor. The intention is to enter the market segment of indoor concrete mixers, where the existing concrete mixers with combustion engines cannot be used. The modular product family augmented with an electric motor as engine is shown in Figure 4-19.

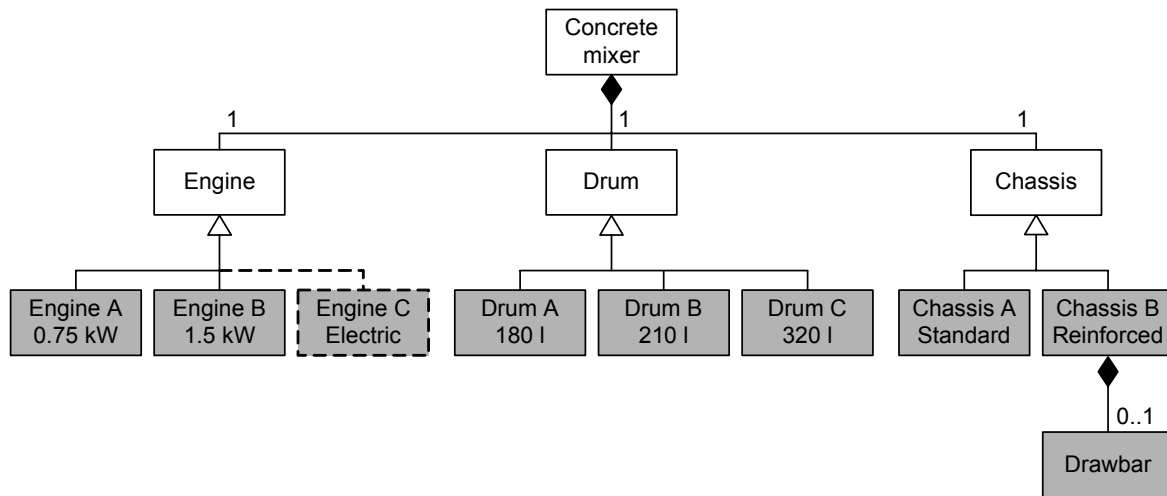

Figure 4-19: Family of concrete mixers augmented with electric motor

The task consists of deciding on a new module variant for the ‘engine’ module. There are two concepts that have been checked using the framework for modular product families and module sheets and thus safeguard the modular product family’s key properties.

- Three phase AC induction motor from existing supplier
- Single-phase AC induction motor from new supplier

The decision maker intends to evaluate and improve these concepts using probabilistic evaluation and improvement. The company uses an innovation process similar the one by ROOZENBURG & EEKELS²¹¹ described in Subsection 2.1.2. The properties and effects caused by a new module or module variant can be seen in Figure 4-20. These effects occur one time in strict development and as often as the product is sold in realization. The decision criteria considered are amount of work and cash flow. Purchasing and sales are measured in cash flow, while all other effects are measured in man hours. Properties are depicted using arrows in Figure 4-20.

211. [Rozenburg and Eekels, 1995], p. 13.

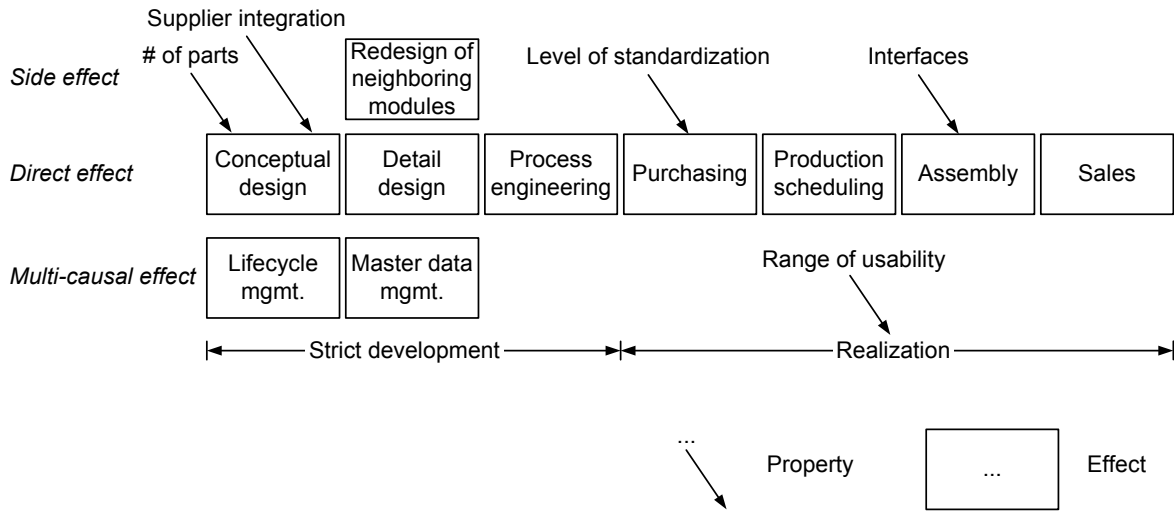

Figure 4-20: Properties and effects for family of concrete mixers

Properties having an impact on effects in the innovation process are the number of parts of the concept for a new module/module variant, the level of supplier integration, the level of standardization of the entire concept and the assembly interfaces. The range of usability of a product determines how often the module variant is going to be sold. As a result, this property has an impact on the number of times that the realization phase of the module variant takes place. It is therefore relevant for all effects that are part of the realization phase. Each of the two concepts is characterized by its values for the above-described properties. The values of the two concepts are given in Table 4-1.

Table 4-1: Property/value table for the two concepts

Property \ Concept	Three-phase motor	Single-phase motor
Number of parts	200 - 500	200 - 500
Supplier integration in conceptual design	Module/module variant from catalog	Minor adaptations required
Level of standardization	Standard product available from multiple suppliers	Standard product available from few suppliers
Assembly interfaces	Unknown	Unknown
Range of usability	10-20% of applications	20-30% of applications

The two concepts are not different in terms of the number of parts. They are, however, different with respect to supplier integration. While the three-phase motor can be ordered directly from a catalog and is thus completely developed by a supplier, the single-phase motor requires minor adaptations. Due to its wider use, the three-phase motor is a standard product available from

multiple suppliers, while the single-phase motor is only available from few suppliers. The assembly interfaces are currently unknown for both the three-phase and the single-phase motor. The range of usability of the single-phase motor is larger due to the wider availability of single-phase power outlets.

Probabilistic evaluation of both concepts is shown in Figure 4-21. The single-phase motor scores better in terms of the expected value of cash flow. The single-phase motor, however, requires a higher amount of work within the innovation process. It is also riskier in terms of both cash flow and amount of work. This can be recognized from the longer lines for the single-phase motor in Figure 4-21.

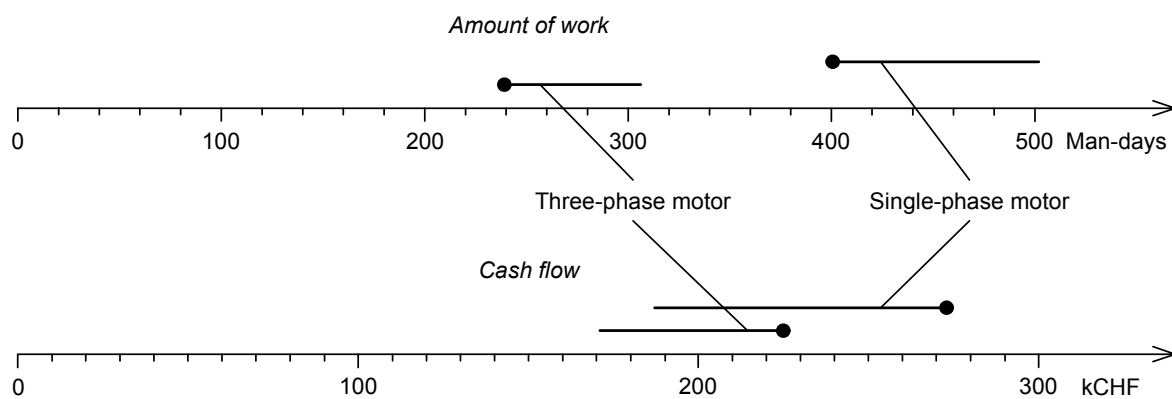

Figure 4-21: Evaluation of the two concepts

The single-phase motor is expected to result in about 48,000 CHF more cash flow than the three-phase motor. Yet, it can also be expected to require about 161 more man-days of work. The additional cash flow is only 298 CHF per man-day invested. The additional effort for the single-phase motor does not pay off. That is why the concept of the three-phase motor is selected.

The objective now consists of improving the selected concept. A significant source of risk is the fact that nothing is known about the assembly interfaces. It is clear from running the simulation that by designing the module variant in such a way that there are only a few standardized assembly interfaces, the concept can be improved significantly. As shown in Figure 4-22, the necessary amount of work can be reduced by about 34 man-days. Risk can be reduced by about one third as compared to the original concept.

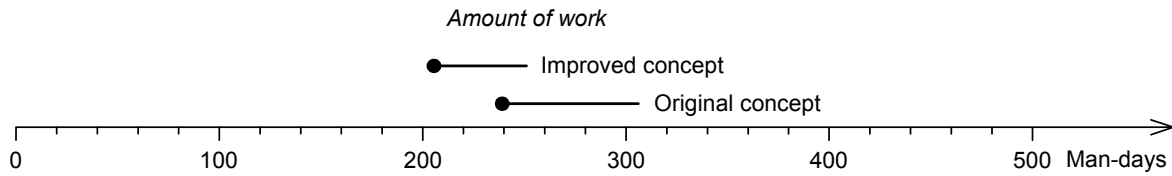

Figure 4-22: Original and improved concept (three-phase motor)

It is obvious from the illustrative example that probabilistic evaluation and improvement can be rapidly applied by entering the values for all properties. The decision maker then obtains expected value and CVaR as a risk assessment for one or multiple decision criteria. These key indicators are used to select the most promising concept. By altering the values of properties, e.g. assembly interfaces in the above example, the decision maker can immediately see the benefit of such modifications. Based on information on the expected cost of a modification, which need to be calculated separately, the decision maker can then consciously improve the concept with respect to expected value and risk of the decision criteria.

4.4.3 Implementation

The process and the documents that are used to implement probabilistic evaluation and improvement are shown in Figure 4-23.

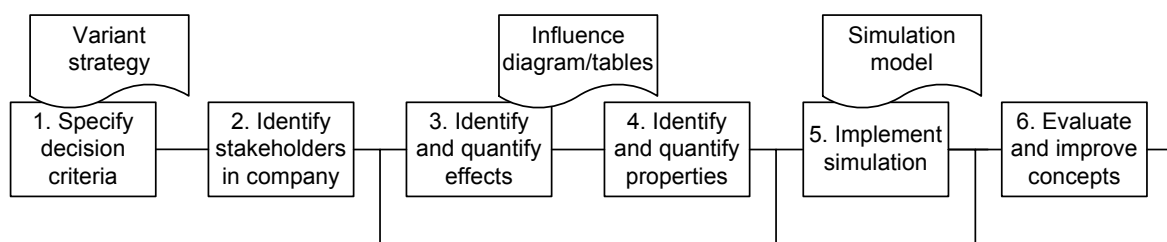

Figure 4-23: Implementation flowchart

The implementation process comprises the following steps.

1. *Specify decision criteria*: The variant strategy is used to derive the decision criteria that are to be used to evaluate concepts for new modules and module variants. On the one hand, the decision criteria should cover the corners of the triangle of objectives discussed in Subsection 2.1.1 as comprehensively as possible. Ideally, one should thus address outcome, effort, and timing. On the other hand, as few decision criteria as possible should be used. This is because every additional decision criterion

increases the effort required for implementing the simulation model and the complexity of the decision for the decision maker. That is why it is proposed here to use cash flow and amount of work.

2. *Identify stakeholders in company*: Once decision criteria have been specified, one can go through the corporate innovation process and identify stakeholders in the company where effects connected to the decision criteria might occur. These stakeholders are generally connected to a department or other organizational unit. Within each relevant organizational unit, one should identify one or several experts. These experts need to have experience with carrying out the innovation process in the respective department. They also need to have very good product and process knowledge.
3. *Identify and quantify effects*: Steps 3 and 4 are repeated for every organizational unit that has been identified as being relevant in Step 2. A workshop or interview is carried out for each organizational unit. In the first part of such a workshop or interview, the effects of new modules and module variants on the different parts of the corporation are identified and quantified in terms of the decision criteria. The workshops and interviews are prepared by establishing a first draft of the effects that may occur with the help of standard operating procedures (SOP). The SOPs can generally be found in the corporate intranet. The draft of effects is then presented to the experts in the scope of the workshops or interviews. The experts correct and augment the first draft and thus identify most effects. Additional effects are identified by well-directed questions of the workshop moderator. The moderator should therefore have knowledge of effects identified in other companies and the literature. The participating experts quantify all effects in terms of the decision criteria. This is done under the assumption that no additional information is available on how the concept looks like. In other words, there is no information on the values of properties.
4. *Identify and quantify properties*: Properties are dealt with in the second part of the workshop or interview. In order to identify and quantify the properties, one should analyze the effects. One needs to address those effects with the largest absolute spread first, i.e. the largest difference between the largest and the lowest possible outcome, because these entail the greatest potential for improvement. The experts are therefore asked to identify the properties that have an impact on the effects with a large spread. Once properties are defined, the experts need to define a value scale for

each property. A distinct probability distribution, probability of occurrence, and conversion rate is then assigned to every value. The information on effects and properties obtained in the interviews or workshops can be stored in influence diagrams or tables. An influence diagram²¹² is generally easier to grasp, while a table can hold more information. The finalization of the influence diagram or table concludes the workshops or interviews with experts.

5. *Implement simulation*: The information from the influence diagrams or tables is transferred into the simulation model in the Excel-based VBA application. The application for probabilistic evaluation and improvement is now ready for use.
6. *Evaluate and improve concepts*: Concepts are evaluated by entering the respective values of properties and observing expected value and CVaR for the decision criteria. The properties in the simulation model which have an impact on effects serve as suggestions for improving a concept. The decision maker takes up these suggestions and improves the concept. The impact on expected value and CVaR of the decision criteria can be observed immediately by reevaluating the modified concept. It is not necessary to build up a new model for every new set of concepts to be evaluated and improved. Instead, the same model can be reused so as to increase the efficiency of the tool. This may require the model to be updated in the case that effects or properties change. The task of building up the complete model, however, remains a one-time effort.

212. Influence diagrams, which are similar to relevance diagrams, belief nets, and Bayesian networks, are singly connected, acyclic, directed graphs with decision, chance, and value nodes as well as conditioning and informational arrows between them, see [Holtzman, 1989], p. 249. They contain both properties and effects as defined in Subsection 4.4.1.

Chapter 5

Case Examples

The concept of the variant management funnel and its underlying tools, i.e. the framework for modular product families, module sheets, and probabilistic evaluation and improvement, have been described in the previous chapter. The variant management funnel has been developed in an applied research project. In this chapter, it is shown how it has been applied and used in two industrial companies, which took part in this project. A case example of a modular product family of railway signals is given in the first section. This product family is at the very beginning of its market phase and is rather simple. A case example of a modular product family for laboratory automation is given in the second section. This product family is at the end of its market phase and is very complex. Within each section, the company context is described first. It is then shown how the tools within the variant management funnel were implemented. Finally, it is described how the variant management funnel was used and the observations that were made by representatives from the companies. Concrete results from the two companies are given.

5.1 Case Example 1 - Railway Signals

5.1.1 Company Context

The railway division of a large, multinational company develops, manufactures, and distributes railway signals. This market can be segmented into home signals, distant signals, subsidiary signals, and tunnel signals. Home signals indicate whether a train may enter the following track section. They also indicate the allowed speed. Distant signals are located ahead of home signals and show the indication of the associated following home signal. This allows a train to stop before the actual home signal. Remaining signals that are neither home nor distant signals are summarized under the term subsidiary signals. Tunnel signals are special due to particular

requirements in terms of size, fixation, and environmental stress. Still, they fulfill the same functions as home, distant, and subsidiary signals.

There is a very large variety of subsidiary and tunnel signals in the company's product portfolio. Products generally stay on the market for several decades. Many of the subsidiary and tunnel signals generate very little turnover and have not been ordered in the past years. 15% of the signals generate more than 95% of the turnover. There also used to be very little commonality among the different end products so that the company could hardly generate any economies of scope. That is why a modular product family for subsidiary and tunnel signals has been introduced to limit variety to only a few components within a signal. The manufacturing costs of end products that are part of the modular product family are about half that of the conventional end products. Initially, the modular product family is only intended to cover the most frequently demanded end products. In the future, the modular product family is, however, projected to grow so as to cover a larger percentage of end products. In this way, the cost advantages of the modular product family can be extended to a larger share of the product portfolio.

The company thus faces the challenge of generating useful modules and module variants for a modular product family and preventing unprofitable modules and module variants. In this context, utility is determined by outcome and effort. The augmented modular product family should cover a larger market segment so that the older and more expensive end products can be phased out. Besides, the additional modules or module variants should be realized at minimum cost and effort. The decision is to be made in product planning when potential new modules and module variants are selected and improved. The task to be fulfilled is thus in line with the definition and positioning of variant management of modular product families in the market phase from Section 2.4. The variant management funnel is therefore applicable.

5.1.2 Implementation

All three tools that are part of the variant management funnel, i.e. the framework for modular product families, module sheets, and probabilistic evaluation, were implemented. The implementation process and results for each single tool are described in the following.

Framework for Modular Product Families

The framework was implemented in collaboration with the product manager responsible for the introduction of the new product family of railway signals. Two interviews of about two hours each were carried out with him. In the first interview, the framework for modular product families was explained. A first draft of the framework for the modular product family of railway signals was created on a sheet of paper based on the understanding of the product manager. The first draft was then digitized in Microsoft Visio and used in the second interview. In the second interview, the framework was corrected and augmented using different sources of information such as assembly and detail drawings as well as schematics that had been prepared in the conceptual design of the modular product family. The basis for defining the above framework was to identify assemblies within the product structure of the product family that are always selected as a group when configuring a signal. These groups were made as large as possible and each group generally fulfils a single function, e.g. the lamp group generates light. The identified groups became modules within the framework for modular product families. The resulting framework for the modular product family of railway signals is shown in Figure 5-1.

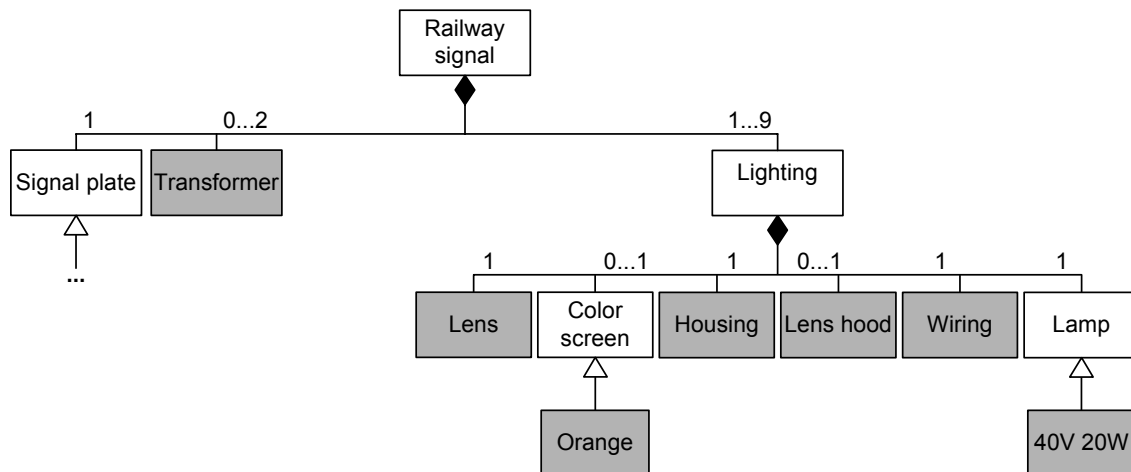

Figure 5-1: Framework for family of railway signals

The product family consists of the three principal assemblies ‘signal plate’, ‘transformer’, and ‘lighting’. There is no variety within the transformer assembly. Only the number of transformers in a railway signal may vary. There is no variety below the transformer and it can be described by a standard BOM. The transformer is therefore modeled as an instance in UML. There is, however, a different signal plate for nearly every end product. The number of variants

of the signal plate is very high and not shown here. The signal plate has standardized interfaces with the rest of the system and can be easily designed.

The lighting assembly is the core of the product structure. It consists of six modules, namely the 'lens', 'color screen', 'housing', 'lens hood', 'wiring', and 'lamp' modules. Most of the variety in the product family is generated through variants of these modules. Variety is limited to quantitative variants of the 'color screen' and 'lens hood' modules. These are functional variants, which are absolutely necessary. Additionally, module variants of the 'color screen' and 'lamp' modules might be introduced in future versions of the product family. Consequently, there may also be component variants in the future. Since there are only a few component variants in the product family, the modules are reused across many end products and there is a high degree of commonality.

Module Sheets

As outlined in Subsection 5.1.1, the product family of railway signals is projected to grow so as to cover a larger percentage of end products. Most new end products will require a variant of the signal plate. These new variants cannot be avoided by intelligent variant management in the market phase. It is rather the result of the initially chosen product structure. For all expansions of the product family that may be envisaged at the current stage, there will be no impact on the transformer assembly. The key to successful variant management of the railway signal family is the lighting assembly. By safeguarding the basic product structure of its modules and its interfaces, one can maintain a high level of commonality across the product family.

There will be no changes to the transformer and new variants of the signal plate are largely arbitrary. Consequently, module sheets were only applied to the lighting assembly. The implementation process was very similar to the implementation process of the framework for modular product families. Implementation took place in two about two-hour meetings with the product manager of the railway signal family. In the first meeting, drafts of module sheets were made. These were digitized using Microsoft Word templates. Although the product manager had most information for filling out the module sheets at hand, some questions remained open. These questions were answered before the second meeting in collaboration with the development department. In the second meeting, module sheets were finalized based on additional information obtained by the product manager.

As an example, the module sheet for the ‘lamp’ module is shown in Figure 5-2. The module sheet follows the structure outlined in Subsection 4.3.1. There are three main sections on the module sheet, namely module characterization, module interfaces, and module configuration.

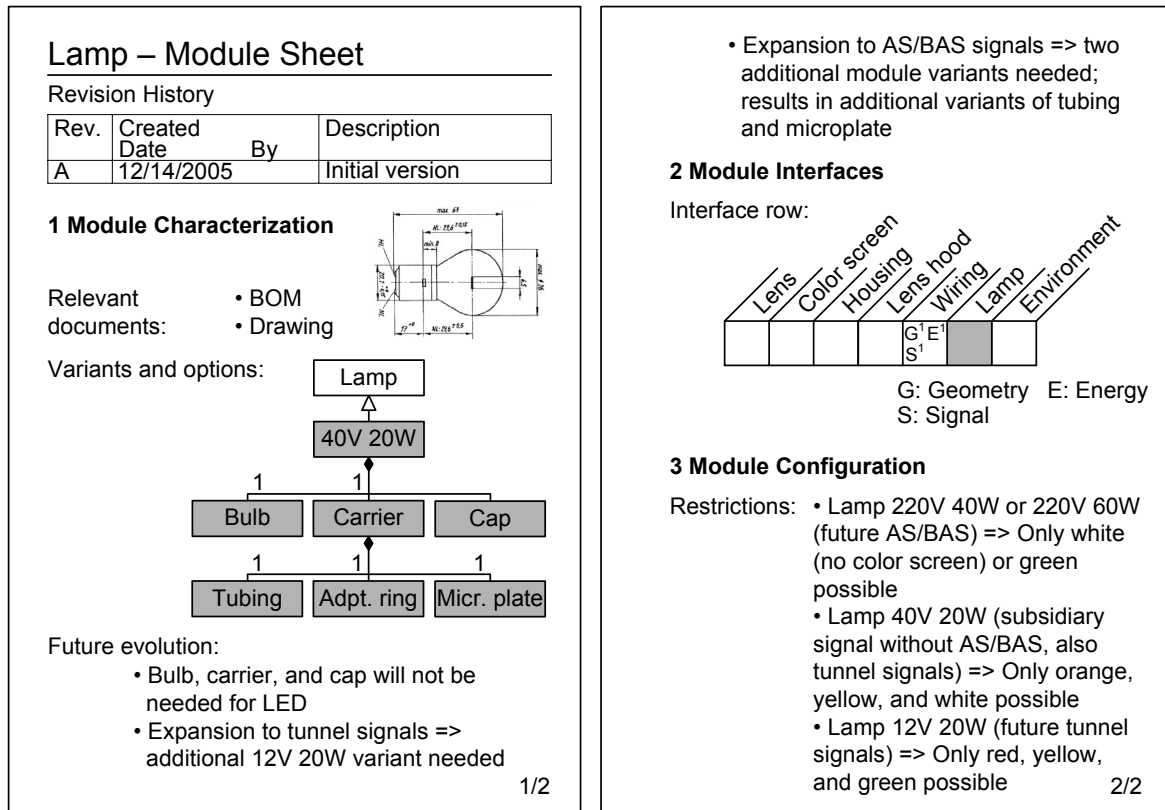

Figure 5-2: Example of module sheet for family of railway signals

Module characterization includes a drawing to facilitate recognition of the module. Relevant documents for the lighting module are a bill of material and a technical drawing. The notation of the framework for modular product families is used to describe variants and options. Currently, there are no variants of the lamp module. There is only a single 40V 20W version. This might, however, change in the future. The 40V 20W version consists of a bulb, a carrier, and a cap. In the subsection on the module’s future evolution, it is described how the module will change if a technological shift is made from light bulbs to light-emitting diodes (LED). Besides, new variants of the module will be needed in case that the product family is expanded to tunnel signals or a larger share of subsidiary signals.

Interfaces are discussed on the second page of the module sheet. An additional column is used for interfaces with the environment. This includes interfaces with the signal plate, the transformer, and the product’s environment, i.e. fixation of the signal.

Restrictions for configuring the module are on the lower part of the second page. The restrictions are given as simple sentences. Currently, there are no restrictions. The restrictions are only relevant for future versions of the lamp module when additional variants will be introduced.

Probabilistic Evaluation and Improvement

The implementation process suggested in Subsection 4.4.3 was used to implement probabilistic evaluation and improvement at the manufacturer of railway signals.

1. *Specify decision criteria:* The variant strategy of the company is to expand the modular product family to cover a larger share of subsidiary and tunnel signals. In doing so, one should target the signals with the highest possible turnover and profit. At the same time, the cost and amount of work for developing and manufacturing the respective signals should be minimized. The decision criteria to be used are therefore cash flow, which can be either positive or negative, and amount of work, which is always positive.
2. *Identify stakeholders in company:* All departments which are involved in the innovation process and affected by decisions in variant management of modular product families in the market phase need to be analyzed. New modules and module variants are to be developed by the development department. The development department is therefore included. Similarly, the signals are manufactured in-house based on bought-in parts. That is why the manufacturing and purchasing departments are also relevant. Finally, the product is sold by the sales department and thus generates positive cash flows. Experienced employees and the department head from each of these departments were asked to participate in separate two-hour interviews.
3. *Identify and quantify effects:* The interviews were prepared by obtaining and studying the company's SOP's. Moreover, a table was prepared to ease the information acquisition process in the workshops. This table includes several columns to record the name of an effect, its probability of occurrence, conversion rate, and so on as described in Subsection 4.4.1. The first half of an interview consisted of filling out this first form by identifying and quantifying effects in the respective departments regardless of whether they are part of the SOP or not.

4. *Identify and quantify properties*: In the second half of the interview, properties were identified for the effects with the largest spread. A value scale was determined for each property and the effects were quantified as a function of the values. This was also done using a prepared table. The results of Steps 3 and 4 were visualized by using a large influence diagram containing effects in all departments involved. A section of this influence diagram is shown in Figure 5-3.
5. *Implement simulation*: The data obtained from the interviews was used for the Excel-based VBA application described in Subsection 4.4.1. Since the tables used in Steps 3 and 4 are structured in the same way as the simulation model within the tool, data could be easily transferred.
6. *Evaluate and improve concepts*: In order to assess utility, the tool was applied to evaluate the expansion of the modular product family to tunnel signals. This is described in the following subsection and validated in Section 6.2 and Section 6.3.

The influence diagram, part of which is shown in Figure 5-3, includes all information on properties and effects obtained from the interviews. Due to confidentiality and lack of space, only a section of the influence diagram is given in Figure 5-3. Still, it can be seen from the figure that effects have been identified in both the strict development and the realization phase. As already outlined in Subsection 4.4.1, effects in strict development occur only once, while effects in the realization phase occur every time an order is placed by a customer. Within strict development, there are effects in the development, purchasing, and manufacturing departments. The development department is not involved in realization. That is why in realization, there are only effects in the purchasing, manufacturing, and sales departments.

Three effects in the development department are given in detail in Figure 5-3. Two of these effects have properties assigned. The properties identified are time pressure, complexity of the module or module variant to be developed, and the place of installation of the signal. The probability distribution and the probability of occurrence of the two effects change as a function of the values of these properties.

One of the effects within realization is the actual sale of the signal. This effect is measured in terms of cash flow. Since the product family replaces existing products within a very stable market, the cash flow generated by the sales price can be easily predicted using past sales prices and the number of end products sold in the past. That is why relevant information on past sales

was collected. This information was summarized in a table that includes sales price and number of products sold for every end product that may be included through expansion of the modular product family. Using this table, the user can make a very accurate estimation of the probability distribution of cash flow generated by sales.

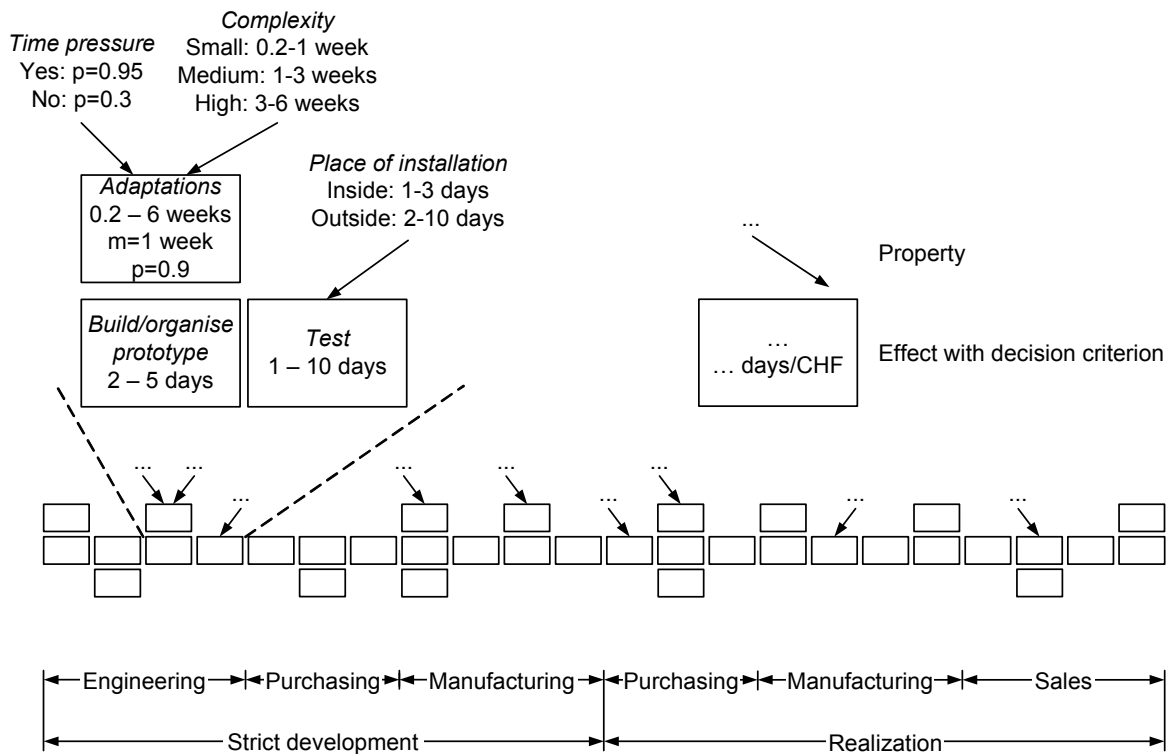

Figure 5-3: Section of influence diagram for family of railway signals

A similar approach was taken for manufacturing costs. Detailed estimations of manufacturing costs were made for different components that might be included into future versions of the product family. These estimations were compiled in a table with all feasible components. A section of this table with changed numbers is shown in Table 5-2. The table was used to make precise predictions of manufacturing costs.

Table 5-1: Estimation of manufacturing costs (numbers changed)

<i>Article #</i>	<i>Description</i>	<i>Manufacturing costs (lower bound)</i>	<i>Manufacturing costs (upper bound)</i>
DHL 12362-43	Lens type 70	52.5 CHF	53.5 CHF
DHL 7632-39	Color screen - orange	20 CHF	20.5 CHF
JHF 13-43	Wiring	10.2 CHF	10.8 CHF
n/a	Spring clamp	5 CHF	7 CHF
n/a	Color screen - red	21.5 CHF	26.5 CHF
...

5.1.3 Use

In the following, it is described how the variant management funnel has been used. The product family has just been introduced to the market and covers an initial range of end products. Expansion of this product family is not discussed right now. Potential new modules and module variants are likely to be discussed in about a year, when the new product family is well established in the market and has proven to be useful. Still, the intention is to assess the variant management funnel in general and for this company in particular. That is why the future decision of expanding the product family was simulated using the variant management funnel. A workshop with the product manager responsible for the product family was carried out for that purpose. The product manager is the person who is responsible for variant management of the product family. That is why he was the ideal person to work with.

The steps that are part of the variant management funnel as shown in Figure 4-2 were carried out. The product manager participated in and observed the use process. This is described in the following. The comments made by the product manager regarding utility of the variant management funnel are also given.

Check Product Structure

The first step in the variant management funnel was to check the product structure. The proposed concept had to fit into the product structure of the existing product family. The framework for modular product families was used in this context. The updated framework with the new modules and module variants needed for tunnel signals is shown in Figure 5-4. New

signalling colors were required for the tunnel signals. That is why a red and a green module variant of the ‘color screen’ module were needed. Moreover, tunnel signals run on a different voltage. That is why a 12V 20W ‘lamp’ module variant had to be implemented. Due to safety reasons, tunnel signals need a micro switch so that any malfunction can be determined in the control center. The micro switch could not be realized as a module variant to an existing module. That is why a new ‘micro switch’ module was needed. Similarly, a diffusing screen was required, which was also realized as a new module. The expansion of the modular product family to tunnel signals thus resulted in two new modules and three new module variants.

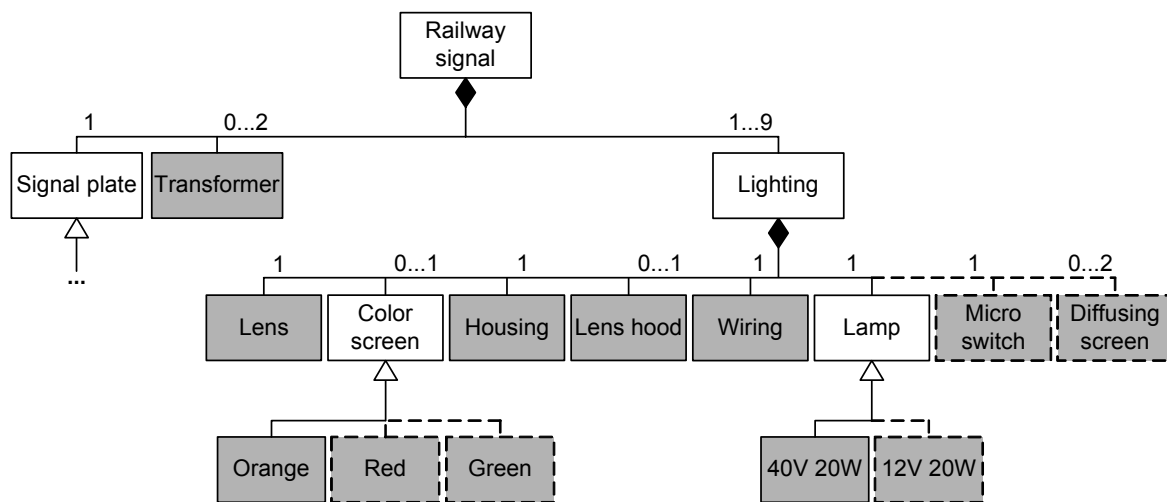

Figure 5-4: Updated framework for family of railway signals

From the point of view of the product manager, the framework for modular product families as part of the variant management funnel definitely allows the user to safeguard the product structure over its lifecycle by adding new modules and module variants. This works only, though, if the product structure is deemed an important property of the product family by those who are responsible for the product family. If this is not the case, then no efforts will be taken in the company to actually safeguard the product structure as laid down in the framework for modular product families.

Check Interfaces

The next step was to check interfaces. Since there are both new modules and module variants, both of the branches in Figure 4-2 were relevant. For the new modules (left branch), new module sheets were created. In the module sheet for the ‘micro switch’, geometric interfaces

with the housing and lamp modules were specified. There are also signal and energy interfaces with the ‘wiring’ module. In the module sheet for the ‘diffusing screen’, geometric interfaces were defined with the ‘lens’, ‘housing’, and ‘color screen’ modules. The new module variants were checked for compatibility in terms of interfaces using the existing module sheets for the color screen and lamp modules. The module sheets were updated with the new variants.

The product manager judged the module sheets as being very valuable for safeguarding interfaces. They include the appropriate type and level of information. He emphasized the importance of integrating the continuous maintenance of module sheets into the company’s processes. Otherwise the module sheets would not be used and become outdated.

Select Concept

Since the product structure and interfaces of the proposed concept are compatible with the existing modular product family, one could proceed to the stakeholder screen. The first step in the stakeholder screen is to select a concept. In this example, however, there was only one concept to choose from. As a result, the decision maker had the choice between implementing this concept and not expanding the product family. The values for the properties, e.g. complexity or place of installation of the signal, were entered into the Excel-based application. Moreover, estimations were made for the number of products to be sold and the sales price. Both estimations were made based on probability distributions and assumptions on future development of the market as a whole, market share, and price level. The simulation results for the resulting amount of work and cash flow are shown in Figure 5-5.

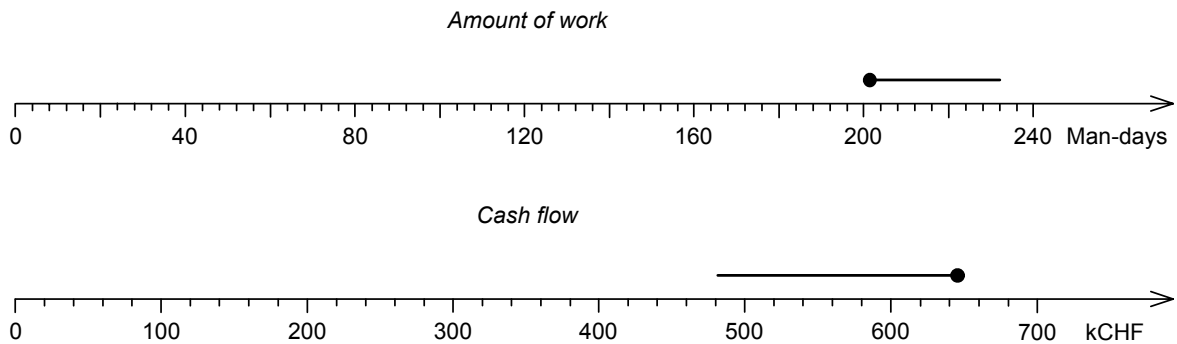

Figure 5-5: Simulation results

The expected amount of work is 201.6 man-days over the entire lifecycle and the expected cash flow is 646 kCHF. One can thus expect to generate about 3,204 CHF per man-day invested. In other words, this expansion of the product family is highly profitable. Moreover, the associated risk is comparatively small. Even in the worst imaginable case, one would still earn 1,422 CHF per man-day invested or 178 CHF per man-hour (assuming eight man-hours per man-day). It is also clear from Figure 5-5 that the risk associated with cash flow is higher than the risk associated with amount of work, i.e. deviations of cash flow are likelier than deviations of amount of work. It was concluded that the expansion of the product family to tunnel signals is highly profitable and should therefore be implemented in the future.

The results that came out of probabilistic evaluation and improvement were judged as plausible by the product manager. From his point of view, the use of probabilistic evaluation provides the appropriate decision basis for selecting concepts. Still, it was outlined, that it can only complement and not replace the experience and intuition of a human decision maker.

Improve Concept

The final task was to improve the concept. This was not actually carried out because one merely dealt with a potential future decision. The effort of elaborating on future improvements was thus not worth the effort. Starting points for improvement could, however, be identified. It was recognized by analyzing the CVaR that the amount of work in strict development incorporates a much smaller level of risk than cash flow from sales in realization. That is why the concept could be improved by obtaining more information about the properties that have an impact on sales price and the number of products to be sold.

The product manager criticized that some of the properties in probabilistic evaluation and improvement, e.g. complexity, were too abstract, i.e. they should be made more concrete and quantitative. The more concrete and quantitative the properties and their value scales, the easier it is to use the variant management funnel to actually improve concepts.

The product manager made the following general remarks with respect to the variant management funnel. It was perceived as an effective method for variant management of modular product families in the market phase. The product manager stated that the method was logical and appropriate for the task. Some limitations of the method were also recognized. Use

of the method requires some effort and thoroughness. It can only work if the required effort is deemed worth while by the decision maker. Moreover, the model in probabilistic evaluation and improvement is based on statements of people from different departments. These statements are based on the individual perspectives of these people and might therefore be subjective. One will also have the possibility to reuse the simulation model for future decisions. This is, however, limited by technology applied in future concepts and the innovation process used. If a future concept is based on a very different technology than the existing product family or realized by a different innovation process, than new workshops or interviews will have to be carried out to update the simulation model.

5.2 Case Example 2 - Liquid Handling Systems

5.2.1 Company Context

The Swiss company develops, manufactures, and distributes liquid handling systems for laboratory automation from multiple locations around the world. The basic function of a liquid handling system is to automatically aspirate and dispense biological and chemical samples from standardized plates, so-called microtiter plates. The system is complemented by readers which are used to detect biological, chemical, or physical events occurring in these samples. Many auxiliary and complementing functions have developed around liquid handling. Liquid handling systems have two primary areas of application. First, they are used in the pharmaceutical industry to discover new drugs. Second, they are applied in clinical diagnostics. The two market segments, pharmaceutical industry and clinical diagnostics, are very different in terms of customer demands. The primary demand in the pharmaceutical industry is high throughput, while the reliability of test results is the driver in clinical diagnostics.

Still, the company employs one single modular product family to cover both segments. This product family has been on the market for about ten years and is projected to stay on the market for another one or two years. There will be some modular innovations to the modular product family within that timeframes. These should safeguard the modular product family's basic product structure as well as its interfaces. New modules and module variants should be evaluated and improved in consideration of development. This corresponds to the task of variant

management of modular product families in the market phase as defined in Section 2.4. The variant management funnel was therefore applied.

5.2.2 Implementation

The implementation process and results of the three tools within the variant management funnel are described in this subsection.

Framework for Modular Product Families

The framework for modular product families, module sheets, and probabilistic evaluation and improvement were implemented in collaboration with a senior scientist having long-term experience with the product family. Due to higher complexity of the product family of liquid handling systems, the implementation of the framework was more elaborate than for the family of railway signals. The application required three meetings with the senior scientist. The senior scientist conferred with other experts in-between these meetings. Additionally, an eight-week student project was carried out, part of which consisted of finalizing the framework. In the scope of this project, the student obtained information from BOMs, the ERP system, and the configurator. The student also interviewed engineers and product managers to finalize the framework for the family of liquid handling systems. This large effort primarily results from the fact that before the implementation of the framework, there was no clear understanding of what were the actual modules and module variants. Consequently, a consensus had to be found by interviewing employees with different viewpoints.

The criteria for defining the framework for modular product families were to set up the product structure from the customer's configuration point of view and to create functionally defined modules. The modular product family has therefore been split up into four groups of modules characterized by functionality. All modules of the 'liquid handling' group deal with the core function of liquid handling. The members of the second group, called 'workplace', provide space and power for most of the other modules. The members of the third group, 'labware handling', provide functions to move and store microtiter plates. The fourth group, called 'assay', carries out analyses of the samples. Each of the four groups includes three to seven modules. Due to lack of space, the framework is only shown down to the level of modules in Figure 5-6. The complete 'storage' module is shown as an example Figure 5-7.

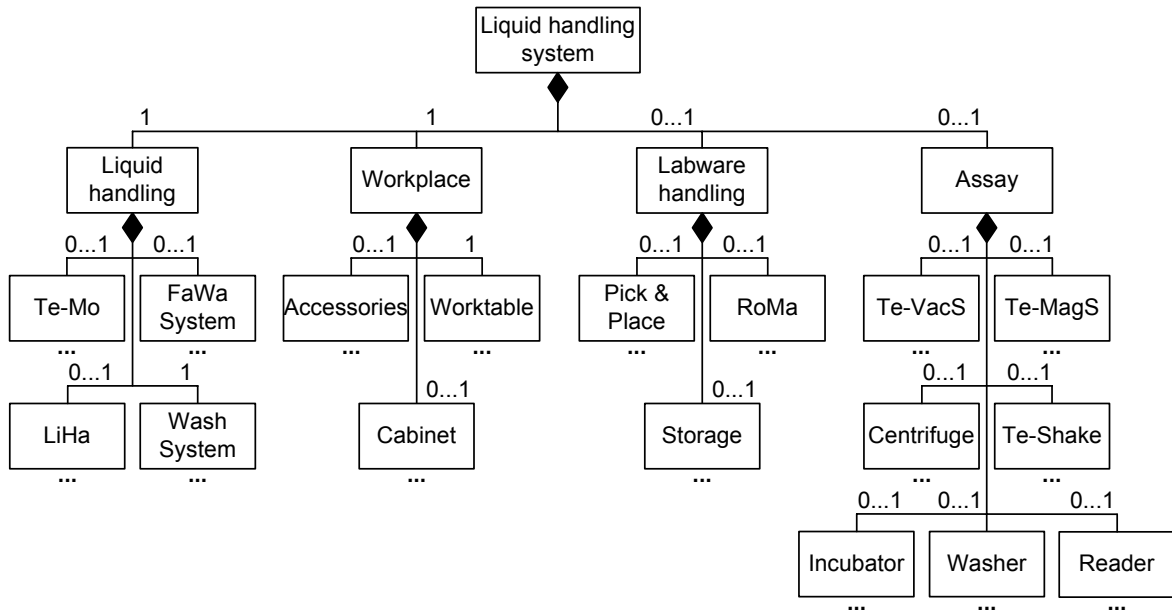

Figure 5-6: Top levels of framework for family of liquid handling systems

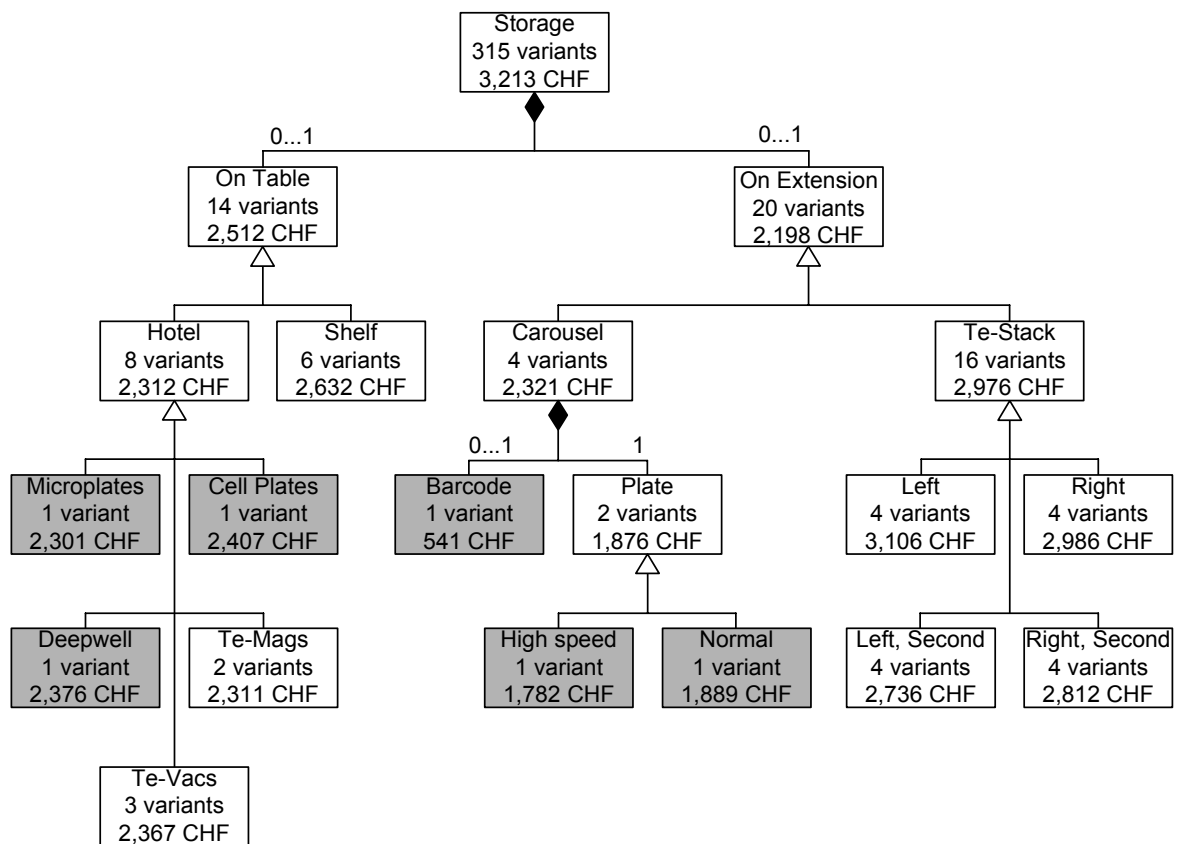

Figure 5-7: Framework for storage module (manufacturing costs changed)

The framework for liquid handling system was enriched with additional information. This includes manufacturing costs and the number of variants of modules, module variants, and lower level components. This information was needed to carry out product analysis as defined in Subsection 2.3.1 and clearly define modules and module variants. Manufacturing costs and number of variants were listed in the respective box for every module, module variant, or lower level component.

The number of variants of a module or the complete modular product family can be calculated based on the variety of its components. Starting from the lowest level of the framework, variety on the next upper level can be calculated as described in the following. Without loss of generality, one may assume a module consisting of two module variants or lower level components. The calculation can be easily expanded to different levels and quantities in the framework. If the notation in Figure 5-8 is used, then v_A and v_B are the number of variants of module variants, v_C and v_D the number of variants of lower level components. The number of variants of a superordinate module having a taxonomy relation is v_T , while it is v_P for a superordinate module with a partonomy relation. The intervals $a...b$ and $c...d$ stand for quantitative variants as introduced in Subsection 4.2.1.



Figure 5-8: Notation for calculating the number of variants

A *taxonomy* implies that a module has several variants, one and only one of which must be selected. Therefore, the number of variants of the module v_T is simply the sum of the variants of its constitutive module variants.

$$v_T = v_A + v_B \quad (5-1)$$

Calculation is more complex for *partonomy* relationships. Calculating the number of possible variants of a lower level component with a multiplicity indicator is a combinatorial problem of

the type combination with repetition²¹³. The number of possible variants is therefore the sum in Equation 5-2.

$$\sum_{i=a}^b \binom{v_C + i - 1}{i} \quad (5-2)$$

The variables a and b are the lower and upper bound of the multiplicity indicators. The two lower level components in Figure 5-8 may be combined arbitrarily. The number of possible variants v_P of the module is calculated as the following product.

$$v_P = \sum_{i=a}^b \binom{v_C + i - 1}{i} \times \sum_{i=c}^d \binom{v_D + i - 1}{i} \quad (5-3)$$

Equations 5-2 and 5-3 were used to calculate the number of variants throughout the modular product family. The number of variants of individual modules ranges from one to 1836. The number of theoretically possible different end products of the entire modular product family is an enormous 6×10^{21} . Due to constraints, some of these end products are impossible to realize, though.

Module Sheets

Interfaces had not been explicitly defined in the company so far. That is why module sheets were applied to explicitly define and safeguard interfaces between modules. Module sheets were presented to the company and a template was provided. The template was used by a senior scientist having experience with the product family to progressively fill out module sheets. As an example, the module sheet for the ‘wash station’ module is shown in Figure 5-9.

Information on commercial relevance was included in the module characterization section in order to get an idea of the sales of the respective module. Besides, the interface row of the module sheets does not include columns for all modules or submodules of the product family.

213. This implies that the order that the variants are chosen in is not relevant and a particular type of variant may be chosen more than once. The formulas for combination with repetition are derived in [Tittmann, 2000], pp. 12-16.

There are only columns for modules where there actually is an interface. If there is no interface and the respective field in the interface would thus be empty, then the column is left out.

As already mentioned in Subsection 4.3.1, different module variants can have different interfaces and therefore require separate interface rows. This is actually the case here as there are four separate interface rows.

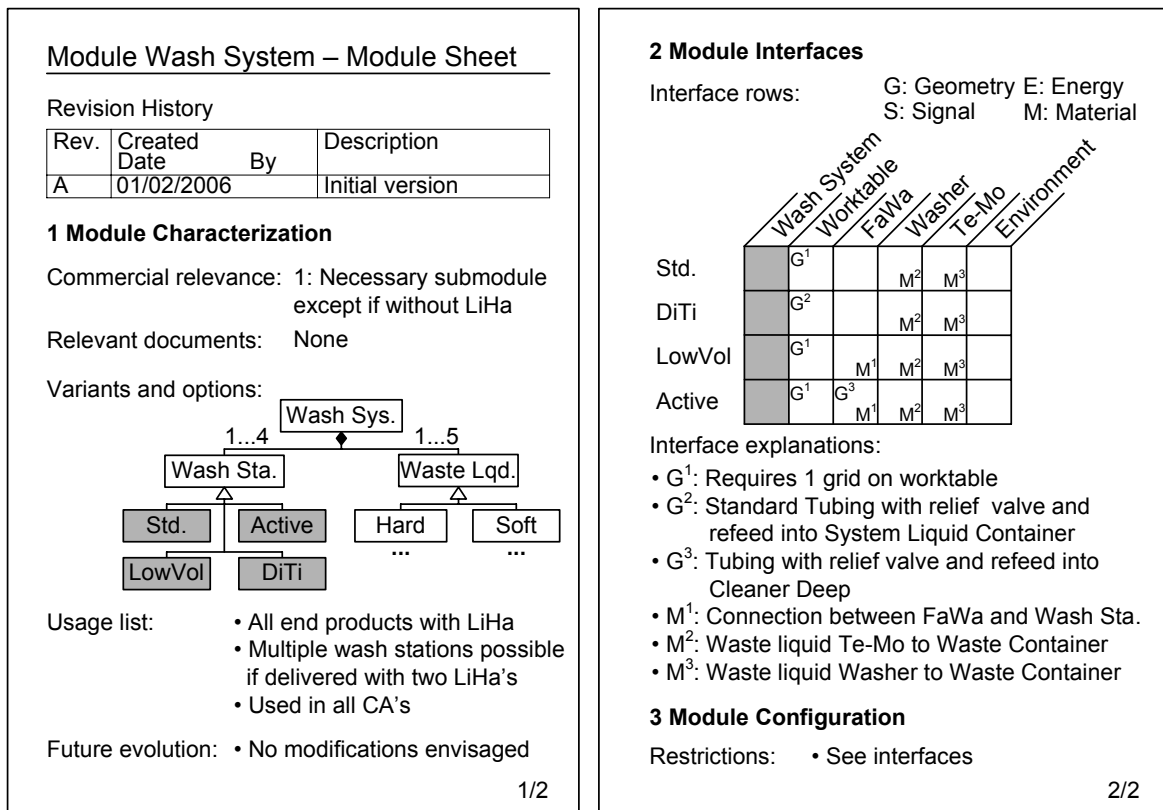

Figure 5-9: Example of module sheet for family of liquid handling systems

Probabilistic Evaluation and Improvement

Probabilistic evaluation and improvement for the liquid handling systems was also implemented using the implementation process suggested in Subsection 4.4.3.

1. *Specify decision criteria:* Since the modular product family is moving towards the end of its market phase, the objective is to confine and reduce variety within the product family. Expenses for additional variants should be limited as far as possible. Due to high development efforts and small numbers of products sold, the amount of work required in strict development is the primary expense. Cash flow accounting for

the benefits of a new module or module variant was not considered as this is already covered in existing decision support used in the company. That is why amount of work in strict development was chosen to be the sole decision criterion here.

2. *Identify stakeholders in company*: Various departments, e.g. logistics, technical documentation, or production, are involved in strict development. The lead over development projects is, however, in the development department. That is why the head of the development department, who has decided on and supervised many development projects was chosen as interview partner.
3. *Identify and quantify effects*: The interview with the head of development proceeded in the same way as in the example of the family of railway signals. The interview was prepared using the company's very detailed SOPs for development projects. These SOP were also used extensively in the interview itself to identify and structure effects. In the first half of the interview, the templates for effects were filled out.
4. *Identify and quantify properties*: In the second half of the interview, properties were identified for those effects with the largest spread and recorded using templates.
5. *Implement simulation*: The data from the interviews was implemented into the Excel-based application.
6. *Evaluate and improve concepts*: The application was used for a past decision on implementing a new module for weighing samples that was introduced on the market a few months ago. The process of deciding on the new module was repeated using the variant management funnel. This way, the process with the use of the variant management funnel could be compared the process without it. The variant management funnel's use in the example of the balance module is described in the next subsection. The benefit of the variant management funnel in this case example is discussed in Section 6.3.

A section of the influence diagram that was elaborated for strict development is shown in Figure 5-10. The influence diagram was structured in the same way as the SOP for the innovation process. That is why the influence diagram is divided into the concept, design input, design output, and product release phases. The milestones M2 to M5 are the transitions between the different phases.

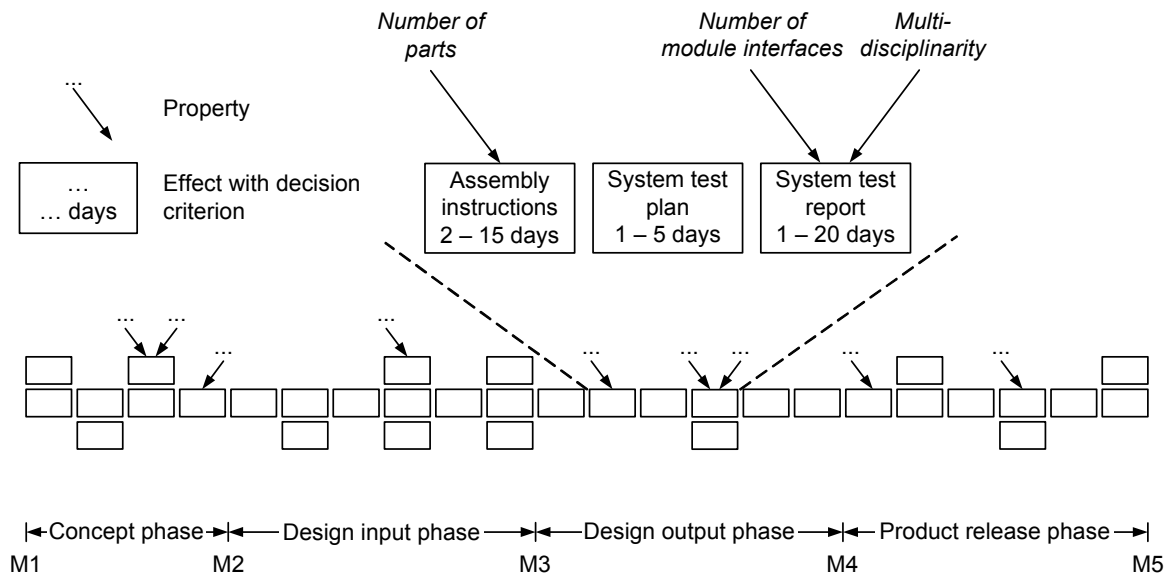

Figure 5-10: Section of influence diagram for family of liquid handling systems

The influence diagram is very detailed. Nine properties and 89 effects have been identified in the four phases. It took about three hours to enter all effects and properties into the Excel-based application. Simulation time also remained acceptable. Running at 2,000 Monte Carlo simulations, where deviations of the key indicators from their actual values are generally within $\pm 0.5\%$, it took 15 seconds to simulate on a standard computer.

A few examples of properties and effects are shown in the upper part of Figure 5-10. Some of the most important properties on the amount of work in strict development were determined to be the level of multidisciplinary of the respective module and the number of functions to be fulfilled by a module's software. The most expensive effects in strict development generally are hardware and software design, user documentation, and product validation.

5.2.3 Use

In the following, it is discussed how the variant management funnel has been used for the decision about introducing a new module for weighing samples. This 'balance' module is used to check whether a sample has been successfully pipetted into a test tube by means of the test tube's weight. This new module has recently been introduced on the market. That is why detailed information on its development process is available. The decision process was repeated

with the help of a senior scientist and using the variant management funnel. This process is described in the following. The remarks made by the senior scientist are also given.

Check Product Structure

The first step was to check the product structure. The proposed concept is a new module. In Figure 5-11, it is shown how it fits into the product structure of the modular product family. Functionally, the balance belongs to ‘labware handling’ and it is no variant of an existing module. It is therefore a new module.

According to the senior scientist with whom the variant management funnel was applied, the framework now allows the company to specify and safeguard the product structure of the modular product family. The primary concern was the initial setup of the framework. This is not unambiguous and required several discussions with employees from different departments to reach a consensus.

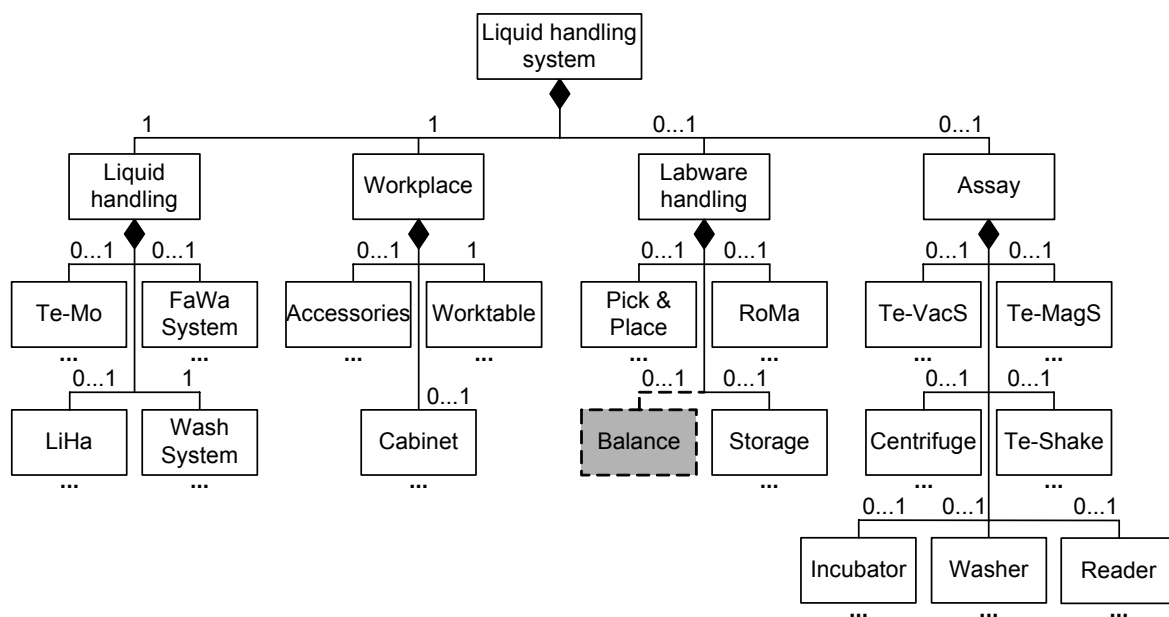

Figure 5-11: Updated framework for family of liquid handling systems

Check Interfaces

Since the balance is a new module, the left branch of the flowchart of the variant management funnel in Figure 4-2 applies. Consequently, one had to check the interfaces using a new module sheet. That is why a new module sheet was set up for the balance module.

In the module characterization section, it was laid down that the balance module only has a small commercial relevance in terms of number of units to be sold. Still, it has a high strategic relevance for the company as it offers a unique selling point. This is because the balance module is the realization of an important function for which no other company offers a solution yet. The module has no variants nor options and no modifications are envisaged in the future. In the module interfaces section of the module sheet, interfaces have been specified with the ‘worktable’, ‘LiHa’, and ‘accessories’ modules as well as the environment. In the module configuration section, it has been stated that there are no restrictions in terms of configuration with other modules.

According to the senior scientist, module sheets are clearly suitable for capturing and safeguarding interfaces between modules in a modular product family. This requires the setup and updating of the module sheets to be specified as part of the company’s SOPs.

Select Concept

Since the new module has been determined to be compatible with the existing product family in terms of product structure and interfaces, the next step was to select a concept. In this example, there was only one concept to choose from. The choice was between implementing and not implementing the concept. The values for the nine properties were identified and used for probabilistic evaluation.

The expected value of the amount of work for the balance module shown in Figure 5-12 is in the lower quarter of possible outcomes of the simulation model. The balance module thus belongs to the simpler modules from the point of view of strict development. From the point of view of probabilistic evaluation, it is thus rather inexpensive to develop. The associated risk is also small. As outlined above, the proposed module offers a unique selling point. That is why the module should clearly be developed from the point of view of the variant management funnel. This was the same conclusion that decision makers came to without applying the proposed method. This was, however, based on a much weaker, qualitative basis for decision.

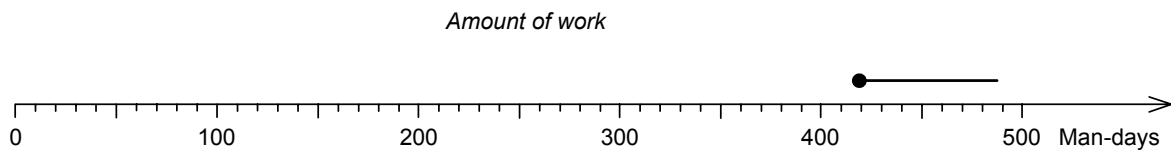

Figure 5-12: Simulation results

In order to obtain a more precise assessment of the predictions from probabilistic evaluation, the expected values were compared to records of project costs from the ERP system. The problem with such records is that they are very often incomplete. A significant proportion of costs, e.g. the writing of manuals, is not directly attributed to the project. This was also the case in the development of the balance module. Several effects that are part of the simulation model had not been recorded in the ERP system. These effects had to be removed from the simulation model in order to make it comparable to the recorded project costs. The costs that occurred between the different milestones ‘M1’ to ‘M5’ are given in Table 5-2. The deviations of the expected from the recorded values are also provided.

Table 5-2: Comparison of expected to recorded values for balance module

	M1 – M5	M1 – M2	M2 – M3	M3 – M4	M4 – M5
Actual value	373 man-days	4 man-days	40 man-days	106 man-days	223 days-days
Deviation of expected value	+12.56%	- 53.92%	+ 266.79%	- 1.53%	- 24.46%

As one can see, the deviation for the entire process of strict development is only +12.56%. Deviation in the concept phase is -53.92%. This may appear large at first glance but when the absolute value of four man days is considered, it is actually quite small. The only significant deviation is in the design input phase. This is due to the fact that most of the work to be done in this phase was completed before the project had officially started. Consequently, most of the costs in this phase were not attributed to the project. Deviations of the expected value in the prototype and product release phase were -1.53% and -24.46% respectively.

Considering that expected values are based on only nine properties and are meant to be perceived as expected outcomes of a random function, the estimations were judged as being quite good by the senior scientist. Besides, one will never be able to make absolutely precise estimations in the product planning phase because the actions that are going to be taken in the later phases cannot all be known in advance.

Improve Concept

The next step would have been to improve the concept. The nine properties that were determined to have an impact on the amount of work should serve as a starting point for making improvements. The benefits of potential improvements can then be seen directly in the expected value and risk of amount of work in strict development. Since the actual product already existed, no improvements could be made. It was, however, checked if the properties identified would provide a suitable way to improve the concept. According to the senior scientist, the nine properties that were determined to have an impact on the amount of work are a good way to improve concepts. Previously implicit knowledge on relationships between properties and effects in variant management is now explicit. The simulation model thus has utility beyond its capability to make estimations. It allows decision makers to better understand interrelationships in the innovation process and thus improve concepts.

The senior scientist also made some comments regarding the variant management funnel in general. The method was judged as an effective approach to variant management of modular product families in the market phase. The senior scientist also stated, however, that a method such as the variant management funnel can only complement the human decision maker, whose expertise will always be required. He also stated that the variant management funnel may become less applicable towards the end of the market phase. This is because it becomes harder to confine concepts to modular innovations. As interfaces and the product structure become outdated, architectural innovation becomes more urgent. The manufacturer of liquid handling systems is currently in this phase. One of the primary perceived benefits of the variant management funnel is that the entire innovation process is analyzed, including side and multi-causal effects. Using the traditional concept evaluation approach in the company, these effects would disappear in overhead costs. Still, overhead costs make up for about half of the costs in strict development. The variant management funnel thus provides a broader and more complete decision basis.

Chapter 6

Validation

Standard approaches to validation in exact science such as mathematics and physics are quantitative and objective. Research in design science and particularly, any prescriptive decision support method as proposed here is often qualitative and may include subjective elements²¹⁴. This type of research is anchored in relativism. Validation approaches acknowledging this fact are therefore required. PEDERSEN ET AL.²¹⁵ propose a validation method called the validation square, which is applied here. There are several reasons why the validation square was selected as a validation approach. First, it was designed specifically for validating methods in design science and is thus highly suitable for the variant management funnel. Second, the validation square rests on a sound philosophical basis. Third, all of the aspects that are relevant in validation are addressed as part of the validation square, namely construct validity, internal validity, external validity, and reliability²¹⁶.

In applying the validation square, the proposed method is evaluated for its structure and its performance both from a theoretical and an empirical point of view. The validation square comprises the four steps shown in Figure 6-1. Each step is discussed in a separate section of this chapter.

1. *Theoretical structural validation*: Section 6.1 is theoretical and focuses on the structure of the proposed method. It needs to be shown that the single tools that the overall method is composed of are valid. This is done by identifying literature that can be used to support the tools. It is also shown that in the overall method, the tools are put together in a consistent way.

214. [Olewnik and Lewis, 2003], p. 2.

215. [Pedersen et al., 2000], pp. 4-6.

216. [Yin, 1994], pp. 32-38.

2. *Empirical structural validation*: The appropriateness of the case examples is discussed in Section 6.2. It is discussed to what extent the two case examples are compatible with variant management of modular product families in the market phase and are sufficient to draw conclusions which may be generalized to other companies and products.
3. *Empirical performance validation*: In Section 6.3, the variant management funnel is assessed against the requirements list from Subsection 3.1.3. This is based on the outcomes of the case examples described in Chapter 5.
4. *Theoretical performance validation*: The validity of the method beyond the two case examples and beyond the requirements from the requirements list is discussed in Section 6.4.

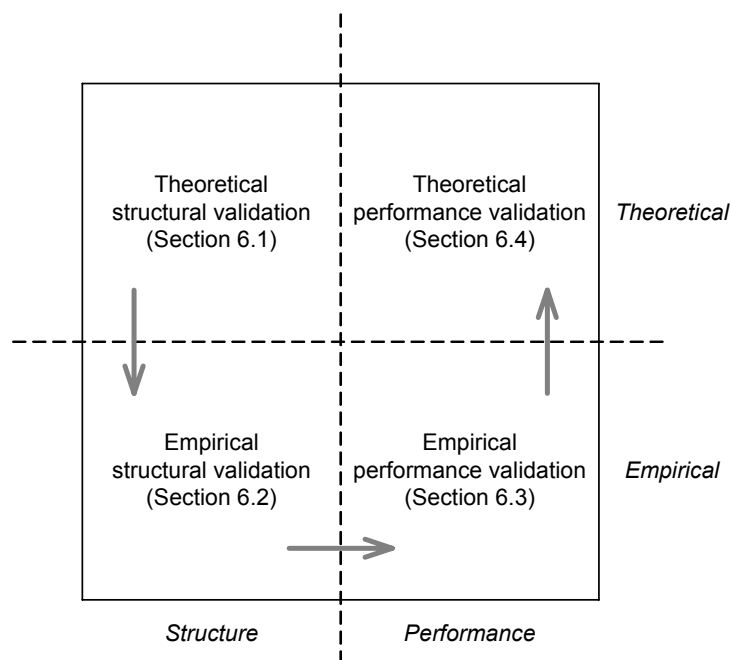

Figure 6-1: Steps of the validation square, based on PEDERSEN ET AL.²¹⁷

6.1 Theoretical Structural Validation

According to PEDERSEN ET AL.²¹⁸, theoretical structural validation involves two aspects. First, it needs to be shown that the individual tools that the proposed method is composed of can be

217. [Pedersen et al., 2000], p. 11.

218. [Pedersen et al., 2000], p. 4.

supported by recognized existing literature. In the context of the variant management funnel, this implies the analysis of the framework for modular product families, module sheets, and probabilistic evaluation and improvement. These are the three tools that the overall method is composed of. This is the topic of Subsection 6.1.1.

Second, one needs to show that the individual tools are put together in a consistent way. A development funnel as defined by WHEELWRIGHT & CLARK²¹⁹ has been used to put together the tools of the variant management funnel. That is why it is discussed in Subsection 6.1.2 whether this overall structure is consistent.

6.1.1 Validation of Individual Tools

The validity of the three tools making up the variant management funnel is shown in this section. This is carried out using flow chart-like diagrams such as Figure 6-2. In these figures, the literature that the tools are built on is shown. The intention in doing so is to show that the tools rest on a solid and logic foundation from the literature.

Framework for Modular Product Families and Module Sheets

The methods and ideas from the literature that the framework for modular product families and the module sheets are built on are shown in Figure 6-2.

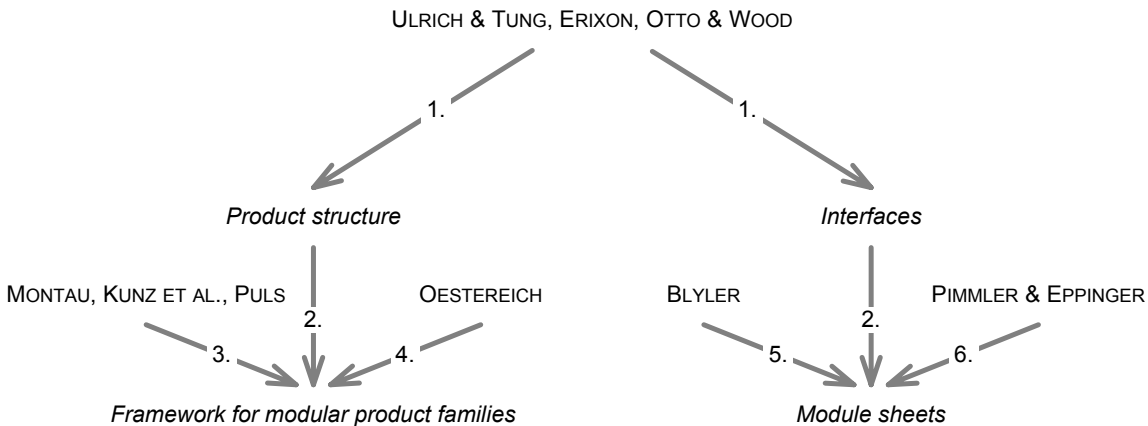

Figure 6-2: Literature used for framework and module sheets

219. [Wheelwright and Clark, 1992].

1. *ULRICH & TUNG*²²⁰, *ERIXON*²²¹, *OTTO & WOOD*²²²: These three publications are among the most recognized when it comes to defining modular product families. In Subsection 2.3.2, the outcome from the application of each of these methods was analyzed. The outcome from all three methods is a defined product structure and a minimization of interactions among modules through the specification of interfaces. That is why it was concluded in Subsection 3.1.1 that product structure and interfaces are the key properties that should be safeguarded in variant management of modular product families in the market phase.
2. *Product structure/interfaces*: The product structure was identified as one of the two key properties to safeguard. According to *SUH*²²³, a good design is one in which the functional requirements are fulfilled independently of each other. In this context, this implies that the requirement of safeguarding the product structure and the requirement of safeguarding interfaces should be fulfilled independently. That is why the framework for modular product families was set up specifically for safeguarding the product structure, while module sheets were set up specifically for interfaces.
3. *MONTAU*²²⁴, *KUNZ ET AL.*²²⁵, *PULS*²²⁶, *MONTAU* and *KUNZ ET AL.* identify three potential types of variety in a product, namely component, structural, and quantitative variants. As described in Subsection 4.2.1, the same type of variant can often be described by different combinations of component and structural variants. That is why these two types of variety are merged. The taxonomy relation described by *PULS* includes both component and structural variants. In addition to taxonomies and quantitative variants, partonomy relations for part-of relationships are needed to describe the product structure of a modular product family. This type of relation is also described by *PULS*.
4. *OESTEREICH*²²⁷: A modeling language was needed to visualize taxonomy, partonomy, and quantitative variants. UML as described by *OESTEREICH* is a recognized modeling language and was used for that purpose.

220. [Ulrich and Tung, 1991] p. 73.

221. [Erixon, 1998], pp. 65-106.

222. [Otto and Wood, 2001], pp. 378-395.

223. [Suh, 1990], p. 47.

224. [Montau, 1996], p. 128.

225. [Kunz et al., 2004], p. 3.

226. [Puls, 2003], pp. 40-42.

227. [Oestereich, 2005], pp. 267-290.

5. *BLYLER*²²⁸: Interface control documents are a recognized approach in systems engineering²²⁹ to document both internal and external interfaces of a system. The concept of interface control documents was particularized in the form of module sheets in order to safeguard the interfaces of a modular product family.
6. *PIMMLER & EPPINGER*²³⁰: The DSM is a recognized way to model interfaces. PIMMLER & EPPINGER introduce four generic types of interfaces into a DSM, namely geometry, energy, signal, and material. One row from a DSM is used on module sheets to describe the interfaces of the respective module with the other modules. If different module variants have different interfaces, several interface rows may be used. It was, however, suggested to adapt the types of interfaces considered to the product family at hand. This was also done in the case examples.

Probabilistic Evaluation and Improvement

The methods and ideas that probabilistic evaluation and improvement is based on are shown in Figure 6-3.

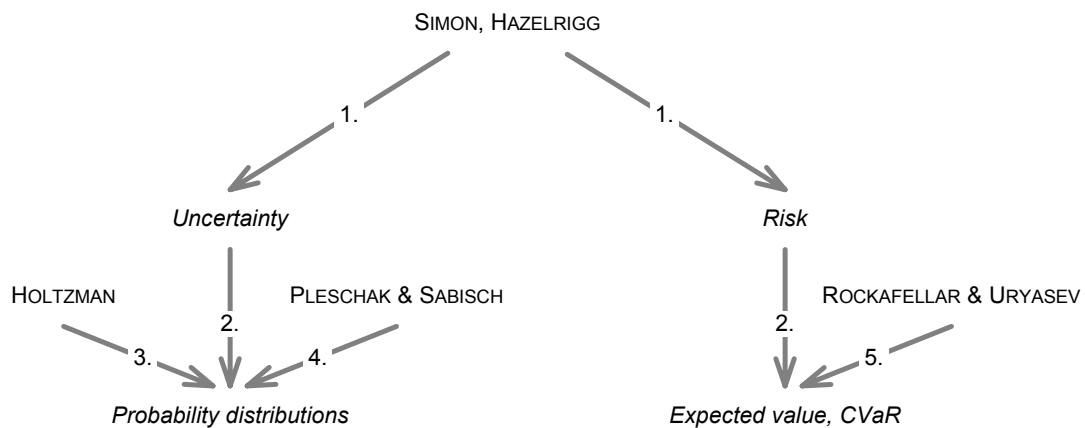

Figure 6-3: Literature used for probabilistic evaluation and improvement

228. [Blyler, 2004], p. 33.

229. [Blanchard, 1998].

230. [Pimmler and Eppinger, 1994], p. 6.

1. *SIMON*²³¹, *HAZELRIGG*²³²: One of the central points put forward by both SIMON and HAZELRIGG is that in a complex environment such as engineering design, decisions cannot be made without considering uncertainty and risk. Uncertainty is the inability to predict future events with precision. Risk results from uncertainty and is the variability of the payoff or outcome. Decisions in variant management of modular product families in the market phase take place in a complex environment with many stakeholders and a long time horizon. Uncertainty and risk therefore need to be considered.
2. *Uncertainty/risk*: Since uncertainty and risk were identified as highly relevant characteristics of decisions in variant management of modular product families in the market phase, probabilistic evaluation and improvement was built around these two aspects. Uncertainty was modeled by means of effects described by probability distributions. Risk was accounted for by calculating the expected value and the CVaR. The expected value serves as a measure of the average outcome that the decision maker can expect, while the CVaR is a quantitative measure of the risk by calculating the average of the ten worst-performing percent of outcomes.
3. *HOLTZMAN*²³³: Influence diagrams are a broadly accepted way of representing interdependencies and effects of a decision. The primary benefits of influence diagrams are that they remain comparatively compact even for complex decisions, can handle uncertainty, and can be used to model interdependencies. The original influence diagram as defined by HOLTZMAN was simplified²³⁴. In order to account for uncertainty in the decision, the effects of a decision were modeled as probability distributions.
4. *PLESCHAK & SABISCH*²³⁵: It is suggested within probabilistic evaluation and improvement to use one or several decision criteria from the triangle of objectives as applied to innovation by PLESCHAK & SABISCH. Not only is this triangle accepted in innovation management but also in project management in general²³⁶.

231. [Simon, 1996], p. 118.

232. [Hazelrigg, 1998], p. 656.

233. [Holtzman, 1989], pp. 56-77.

234. Chance nodes were eliminated.

235. [Pleschak and Sabisch, 1996], p. 9.

236. [Kerzner, 2003], p. 4.

5. *ROCKAFELLAR & URYASEV*²³⁷: Using Monte Carlo simulation, approximations of the overall probability distributions are obtained for all decision criteria. Probability distributions are too complex and provide too much information for decision making and are therefore generally not used for that purpose. That is why this information is condensed into the expected value and the CVaR. The expected value is what a risk-neutral decision maker will be interested in as it is the measure of the average outcome. The CVaR as proposed by *ROCKAFELLAR & URYASEV* is an accepted measure of risk in the risk management literature and has good mathematical properties²³⁸. That is why expected value and CVaR represent a compact, yet complete decision basis.

6.1.2 Validation of Overall Structure

It now needs to be shown that the three individual tools, i.e. framework for modular product families, module sheets, and probabilistic evaluation and improvement, were put together consistently. In other words, it needs to be shown that variant management of modular product families in the market phase is a problem to which the development funnel as defined by *WHEELWRIGHT & CLARK*²³⁹ can be applied. It also needs to be shown that the three tools were put together in a way that is compatible with the development funnel.

A development funnel is applicable in an environment where one starts with a broad range of inputs and gradually refines and selects among them. The outcome of a development funnel is a handful of formal development projects that can be pushed to rapid completion and market launch²⁴⁰. Variant management of modular product families in the market phase is a refinement of the above-described scenario. Its inputs are concepts for new modules and module variants and the basis for refinement and selection are the modular product family's key properties and the variant strategy. The objective of a development funnel is to provide a framework for generating and reviewing concepts, the sequence of critical decisions, and the nature of decision making²⁴¹. This is exactly the research objective stated in Subsection 1.3.1, namely to review

237. [Rockafellar and Uryasev, 2001], p. 24.

238. See [Pflug, 2000], p. 275 for a description of the CVaR's mathematical properties.

239. [Wheelwright and Clark, 1992], pp. 111-132.

240. [Wheelwright and Clark, 1992], p. 111.

241. [Wheelwright and Clark, 1992], p. 112.

concepts in a structured manner by assessing the effects that a new module or module variant will cause. It can therefore be concluded that the development funnel as defined by WHEELWRIGHT & CLARK is clearly applicable to variant management of modular product families in the market phase.

As already stated in Section 4.1, the management of development funnel involves three tasks, namely to ensure a constant stream of products, to set up screens, and to manage development projects. The focus here was on defining the screens. In the development funnel, this is to be done by setting up screening criteria that fit with the company's technological opportunities and make effective use of its resources²⁴². This first aspect was realized by the framework for modular product families and module sheets in the compatibility screen. Only concepts meeting the technological requirements (i.e. product structure and interfaces) imposed by the existing product family pass the compatibility screen. The second aspect was realized by probabilistic evaluation and improvement in the stakeholder screen. Concepts are evaluated by means of decision criteria derived from variant strategy and evaluated across development, manufacturing, sales, and all other departments involved in the innovation process. That is why one can conclude that the three tools have been put together in a way that is compatible with the development funnel by WHEELWRIGHT & CLARK.

6.2 Empirical Structural Validation

It is now discussed whether the two case examples are compatible with variant management of modular product families in the market phase. Moreover, it is evaluated whether the two case examples provide a sufficient basis to make conclusions on the proposed method.

The entire second chapter deals with positioning and defining variant management of modular product families in the market phase. The chapter concludes with Figure 2-14 in which variant management of modular product families in the market phase is positioned with respect to innovation, variant management, and product structuring. That is why it needs to be demonstrated here that the two case examples are positioned in the same way as variant management of modular product families in the market phase. This is shown in Figure 6-4.

242. [Wheelwright and Clark, 1992], p. 113.

Design science	Innovation	Objective	Normative	Strategic	Operative	
		Process	Product planning	Strict development	Realization	
		Outcome	Architectural		Modular	
	Variant management	Level	Strategic		Operative	
		Approach	Variant generation	Variant prevention	Variant reduction	Variant handling
	Product structuring	Approach	Product design	Product analysis	Product family simplification	
		Type	Construction kit	Modular product family	Size range	Packages
		Phase	Initial product structuring		Derivative product structuring	

	Variant management of modular product families in the market phase	①	Case example 1 – Railway signals
		②	Case example 2 – Liquid handling systems

Figure 6-4: Compatibility of case examples

The positioning of the two case examples is described in the following.

- Innovation - Objective:* The objective of variant management of modular product families in the market phase as defined in Subsection 2.1.4 is to successfully translate a given product strategy into new modules and module variants. The decision criteria are within the triangle of objectives given in Figure 2-3 (outcome, effort, and timing). Both examples are operative because the product strategy was given in the form of an existing product family targeted for a specific market or market segment. This strategy was to be translated into new modules and module variants. In the case example of railway signals, amount of work (timing) and cash flow (outcome/effort) were chosen to be the decision criteria. In the case example of liquid handling systems, the sole decision criterion was amount of work (timing).
- Innovation - Process:* Variant management of modular product families takes place in product planning while considering strict development and realization. In the example of railway signals, the decision of introducing new modules and module variants was simulated in product planning in consideration of strict development and realization. In the example of liquid handling systems, the decision of introducing a new module was repeated while considering strict development.

- *Innovation - Outcome*: The outcome was defined to be a new module or module variant to an existing product family already in the market. In both case examples, the outcome was modular being a new module or module variant for a modular product family already in the market. The difference between the two case examples is that the family of railway signals is at the beginning of its market phase, while the family of liquid handling systems is moving towards its end.
- *Variant management - Level*: In Subsection 2.2.3, the level was defined to be operative because the task consists of aligning the existing product family with the variant strategy under the influence of changing markets and technologies. Both case examples were on the operative level in this sense.
- *Variant management - Approach*: Potential approaches were determined to be the generation of useful variants and the prevention of unprofitable variants. Both case examples deal with the former approach. The latter approach was not explicitly dealt with. This limitation is further discussed in Section 6.4.
- *Product structuring - Approach*: In Subsection 2.3.4, product analysis and product design were defined to be part of variant management of modular product families. Both aspects were covered in the case examples. First, product analysis was carried out to implement the framework for modular product families and module sheets. Second, product design was performed in applying the variant management funnel to decide on new modules and module variants.
- *Product structuring - Type*: A modular product family was defined as having a deliberate product architecture and few interactions among modules. Both product families in the case examples meet this definition.
- *Product structuring - Phase*: Variant management of modular product families was determined to involve derivative product structuring. In derivative product structuring, an existing basic product structure is maintained and updated by developing new derivatives, such as modules or module variants. Both case examples involve the development of such derivatives and thus belong to derivative product structuring.

Based on the above considerations, it is concluded that the two case examples are compatible with the definition of variant management of modular product families in the market phase from Chapter 2. It remains to be shown that the two case examples are sufficient for drawing conclusions on the method's validity.

The variant management funnel was applied in two highly different case examples. The two case examples differ among other things in terms of the complexity of the product family, their lifecycles, and industry sectors. Moreover, the variant management funnel was implemented completely in both case examples with all three tools included. Finally, the implementation and use of the variant management funnel was overseen by experienced employees in the two companies (product manager and senior scientist, respectively). These people have experience and knowledge of what constitutes a good decision in variant management of modular product families in the market phase. That is why they were very qualified for supervising and critically evaluating implementation and use of the variant management funnel. What limits the two case examples, is the relatively short time frame of observation during which the variant management funnel was used. Although the variant management funnel will certainly continue to be used in the two companies, the two case examples only describe one instance each in which the variant management funnel was applied to a decision. That is why no immediate conclusions regarding the variant management funnel's long-term effects can be made from the two case examples.

It is concluded here that the two case examples generally provide a sufficient basis for drawing conclusions but are limited with respect to long-term effects. Moreover, no concepts were discarded in the compatibility screen. It has thus not been shown in the case examples that an unprofitable module or module variant has been prevented.

6.3 Empirical Performance Validation

The performance of the variant management funnel is now assessed against the requirements list from Subsection 3.1.3. The individual requirements are discussed in the following and summarized in Figure 6-5.

1. *Product structure*: As described in Subsection 3.1.1, the use of the proposed method has to enforce safeguarding of the product structure of the modular product family down to the level of modules and module variants. This was clearly the case in the two examples. In both case examples, the product structure was captured and safeguarded using the framework for modular product families. The limitation is, however, that variant management funnel alone does not ensure that the product structure is safeguarded. The framework must be appropriately applied capturing the

product structure that is to be safeguarded in the long-term. Safeguarding the modular product family's product structure may also come at a cost, which the decision maker must be willing to pay.

2. *Interfaces*: Application of the method by the decision maker also has to enforce safeguarding of the product family's interfaces. It has been shown in the two case examples that this requirement can be fulfilled using module sheets. The precondition here is, however, that interfaces are thoroughly specified on module sheets and that these specifications are respected in variant management of the modular product family.
3. *Resources*: The proposed method has to facilitate safeguarding product structure and interfaces in a simple way that requires no extensive previous knowledge nor infrastructure. Its application should be quick. The framework for modular product families and module sheets within the variant management funnel require virtually no previous knowledge. The only knowledge that the user might generally not have are the terms taxonomy and paronomy as well as a few elements from the UML notation. These are easily teachable, though. The application of the framework for modular product families and module sheets is rapid. The information acquisition process can be supported by diagramming software (framework for modular product families) and a word processor (module sheets).
4. *Evaluation*: In Subsection 3.1.2, it was stated that the method must allow the decision maker to evaluate concepts using decision criteria within the three dimensions of the triangle of objectives (Figure 2-3). It also has to account for the broad scope of effects of decisions in variant management of modular product families. Probabilistic evaluation and improvement within the variant management funnel as used in the two case examples has been based on decision criteria from the triangle of objectives evaluated for all stakeholders in the company that were judged as being significant. In the liquid handling case example, a past concept was evaluated and compared to actual recorded costs. It was observed that the expected value predicted by probabilistic evaluation and improvement deviated a mere 12.56% from the recorded value.
5. *Improvement*: The method must provide the decision maker with hints of how the selected concept could be improved and also provide a simple evaluation of the modified concept. In probabilistic evaluation and improvement, these hints were

provided in the form of properties. The decision maker should try to alter the values of these properties to improve the concept. The resulting modified concept can be easily evaluated by simulating again. In the case examples, the properties having an impact on effects, e.g. multidisciplinary or number of parts, were also recognized as starting points for improvement by decision makers. This was, however, not carried through. As recognized in the last section, this leads to a limited basis for conclusions.

6. *Quantitative*: The evaluation and improvement of alternatives should be quantitative. Probabilistic evaluation and improvement clearly is quantitative.
7. *Uncertainty/risk*: Both uncertainty defined as the inability to precisely predict future events and risk defined as the resulting variability of a decision's outcome must be incorporated into the method. In probabilistic evaluation and improvement, uncertainty is accounted for using probability distributions and probabilities of occurrence for modeling effects. Risk is accounted for by providing the decision maker with the expected value and the CVaR. The inclusion of uncertainty and risk was acclaimed by decision makers in the case examples.
8. *Resources*: The method has to allow the decision maker to evaluate a concept within a couple of minutes. This requirement has been fulfilled. Selecting the values of properties for a concept generally takes a couple of minutes and simulation can be carried out within 15 seconds. Moreover, the effort for setting up the method through workshops and interviews should be rather small as well. Still, this requirement has not been completely fulfilled. This is because the number of theoretically possible different variants of the same effect increases exponentially with the number of properties that have an impact on it. This represented no limitation in the two case examples, as the resulting complexity could still be managed in the workshops. Still, this might represent a limitation in more complex decisions, i.e. higher number of properties, and is therefore discussed in Section 6.4. The simulation model can also be reused. It has been applied to additional decisions at the liquid handling company not discussed in the respective case example here. In these decisions, the same simulation model was reused.

In summary, the safeguarding of key properties will only work under certain preconditions. This is the willingness to pay for the short-term cost of safeguarding interfaces in return for the long-term benefit of a modular product family. The improvement of concepts has only been partially

addressed in the two case examples. Still, it is concluded here that all of the requirements have been mostly or completely fulfilled by the variant management funnel. An overview of the performance in the two case examples against the requirements list is given in Figure 6-5.

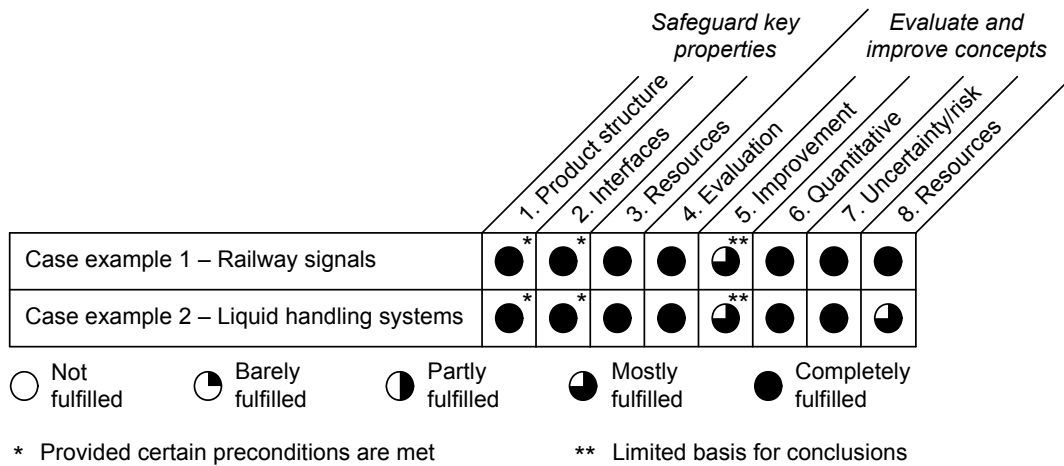

Figure 6-5: Evaluation against requirements list

6.4 Theoretical Performance Validation

So far, it has been shown that the variant management funnel is based on tools supported by literature, which were put together in a consistent way. The two case examples were compatible with the method and largely fulfilled the requirements. In this section, it is discussed to what extent the variant management funnel is valid beyond the two case examples and the eight requirements from Subsection 3.1.3.

According to *Pedersen et al.*²⁴³, this step of the validation square is largely based on circumstantial evidence and faith. Still, this step should also be structured. That is why the approach shown in Figure 6-6 is used here. First, the limitations confining expansion of the variant management funnel to other case examples and adaptation to further requirements are specified. This is done in Subsection 6.4.1. It includes, for instance, the empirical basis, the limitation in terms of complexity that may be handled, and the simplifications that were made in developing the variant management funnel. Second, the range of validity of the variant management funnel is determined by pushing it as far as allowed by the previously specified limitations. This aspect is covered in Subsection 6.4.2.

243. [Pedersen et al., 2000], p. 6.

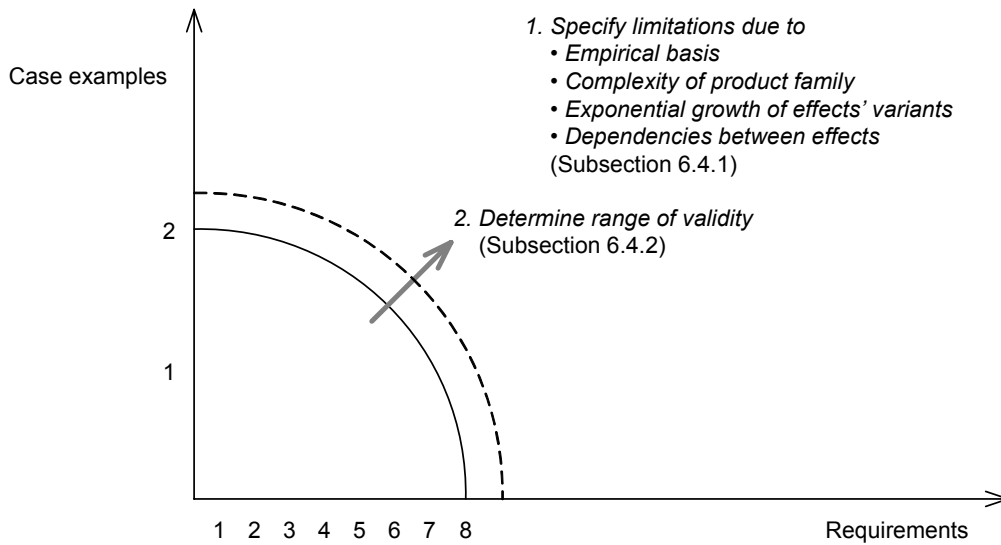

Figure 6-6: Theoretical performance validation

6.4.1 Limitations

The following limitations restrict the extent to which validity can be claimed beyond the original case examples and requirements.

Empirical Basis

As already pointed out in Section 6.2, there is no long-term experience with the variant management funnel. It is not clear how its extended application will affect the company's product portfolio in the long run. Consequently, there is no empirical proof that the variant management funnel will reduce the growth of the number of variants. Conclusions on the long-term effects are assumptions founded on apparent properties of the method.

It has also not been shown how the simulation model that underlies probabilistic evaluation and improvement is to be updated as the effects of variant management of modular product families change over time. Although this is not the case, it is reasonable to assume that probabilistic evaluation and improvement can be updated with practicable effort. First, it only took a handful of workshops to implement probabilistic evaluation and improvement from scratch. Second, if there are major changes in terms of effects, one will still be able to build on what has been done before. The previously established influence diagram can be updated by simply eliminating, modifying, and adding effects.

Complexity of Product Family

Complexity of a product family in terms of the number of modules, interfaces, and configuration rules may pose a challenge when implementing module sheets. This is apparent from the difference between the railway signal and the liquid handling case example. In the former, module sheets are very compact, while in the latter the module interface section and the module configuration section have to hold a lot of information. In the case of liquid handling systems, which consist of around 10,000 parts and have around 90 interfaces between modules, this amount of information is still manageable. In the case of very complex products such as a car, it is believed that module sheets will only be suitable if a large amount of the information contained can be compiled automatically, e.g. from PLM or CAD systems.

Exponential Growth of Effects' Variants

As defined in Subsection 4.4.1, an effect is characterized by three pieces of information, i.e. a probability distribution (for direct, side, and multi-causal effects), a probability of occurrence (for side and multi-causal effects), and a conversion rate (for multi-causal effects). If there is no property assigned to an effect, then there will be only one set of these pieces of information, i.e. one variant of this effect. If there is a property assigned that can take, for instance, three values, then the three pieces of information must be specified for every single one of the three possible values. Consequently, there will be three variants of that effect. For two properties with three possible values each, there will be nine variants and so on. This exponential growth of the number of variants of an effect is illustrated in Figure 6-7.

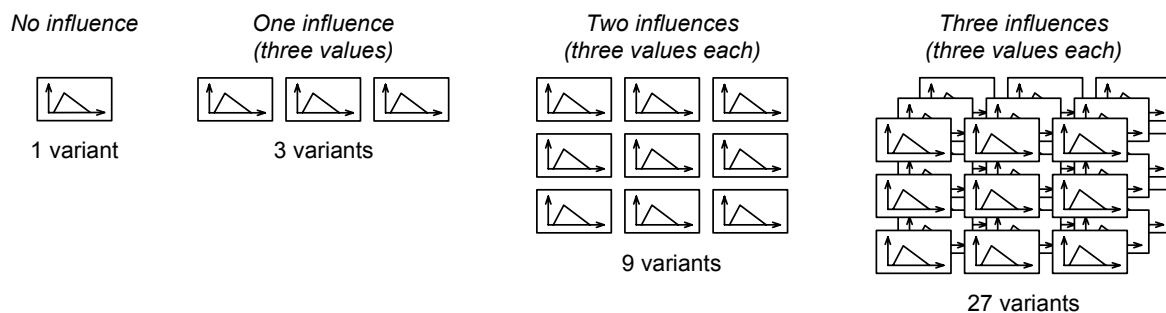

Figure 6-7: Growth of number of effects' variants

Generally, it can be said that any effect with more than two assigned properties is unmanageable. This is due to the number of probability distributions to be determined in a

workshop or interview and also due to the absence of such detailed information. In workshops or interviews, this problem can be alleviated by splitting up one large effect with many properties into several smaller effects with fewer properties each. If the mapping between properties and effects were modeled by a matrix, one would thus strive to diagonalize this matrix.

Dependencies Between Effects

Many of the effects in variant management of modular product families are statistically dependent, i.e. the conditional probability distribution of Effect B given that Effect A has produced a particular outcome is not the same as if Effect A's outcome had not been observed. Let for instance Effect A be the amount of work in conceptual design and Effect B the amount of work in detail design. Then the conditional probability distribution of the amount of work in detail design given a large amount of work in conceptual design will be different from the distribution when nothing is known about the amount of work in conceptual design. One may therefore expect some sort of statistical dependency between the two effects.

The reason for two effects being statistically dependent is that both effects have one or several properties in common. Going back to the example of amount of work in conceptual and detail design, the common property might be the number of parts of the product to be developed. The property 'number of parts' has an impact on both effects, 'amount of work in conceptual design' and 'amount of work in detail design'. As illustrated in Figure 6-8, there is a causality between the property and the two effects. As a result of this causality, the two effects are statistically dependent.

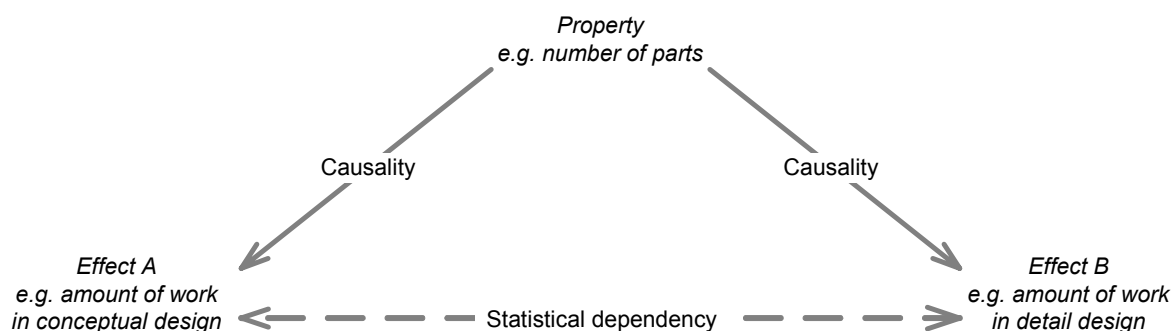

Figure 6-8: Disambiguation between causality and dependency

Statistical dependencies can only be modeled using multidimensional probability distributions. These are, however, virtually impossible to obtain from decision makers. That is why it was decided to model properties but not statistical dependencies. There are two instances where this simplification may reduce the accuracy of the simulation model.

- *Properties not modeled*: Two effects are statistically dependent but the underlying property causing this dependency are not modeled. As a result, the statistical dependency is neglected.
- *Properties set to 'unknown'*: In evaluating and improving concepts, the decision maker can choose among a range of values for each property thus characterizing the concept. In doing so, the decision maker can always set the value of an property to 'unknown' if the value for the evaluated concept is not known at the time of decision. By choosing 'unknown', the respective property is disabled and a wider probability distribution is chosen as shown in Figure 4-13. The statistical dependency is once again neglected.

The consequence of neglecting statistical dependency is that the overall probability distributions calculated using Monte Carlo simulation become inaccurate. The level of inaccuracy depends on the number and importance of properties not modeled or set to 'unknown'. It also depends on the spread of the related probability distributions. Consequently, it is important in implementing probabilistic evaluation and improvement to identify as many properties as possible. It is particularly important to find those properties that have a large impact on effects with a large absolute spread. The decision maker should set as few properties to 'unknown' as possible. The decision maker should be aware that setting properties to 'unknown' results in inaccuracy of the predictions made.

6.4.2 Range of Validity

Based on the limitations identified in the previous subsection, it is now determined to what extent the variant management funnel can be expanded to new case examples and requirements. This is not entirely inductive but requires some confidence in the method²⁴⁴.

244. [Pedersen et al., 2000], p. 6.

In terms of expansion to additional case examples, it is concluded here that the variant management funnel will generally work in case examples with a suitable level of complexity, identified properties, and process-orientation.

- *Complexity*: The variant management funnel has been shown to work with products of the level of complexity of liquid handling systems. Complexity is defined here as the number of parts, modules, and interfaces. Based on the experiences from this case example, it is concluded that the variant management funnel will also work for product families with a lower to slightly higher complexity.
- *Identified properties*: The simulation model for probabilistic evaluation and improvement will be accurate if a high number of properties has been identified, particularly for effects with a large absolute spread. The liquid handling case example with 30 out of a total of 89 effects having properties assigned produced acceptable results. Also no more than five out of nine properties were set to unknown in evaluating concepts. That is why probabilistic evaluation will probably work if at least one third of all effects are assigned properties and no more than half of the properties are set to unknown. Also, the identified properties have to be the important ones, i.e. those properties with a large impact on effects with a large spread.
- *Process-orientation*: One of the recognized limitations has been the exponential growth of the number of variants of an effect with properties. This can be compensated for by dividing up large effects into smaller ones. This is particularly simple for effects that occur along a process, e.g. most of the effects within an innovation process, because they can be simply broken down into smaller process steps. That is why the variant management funnel will generally work for process-oriented effects. This will be the case for most decisions in variant management of modular product families in the market phase because innovation can be thought of as a process.

It remains to be discussed to what extent the variant management funnel can be extended to more far-reaching requirements. Since it is not possible to assess the potential for expansion to every other thinkable requirement, it is focused on the most important requirement not discussed so far. This is the requirement of meeting the industrial subobjective stated in Subsection 1.3.1 of limiting the increase of new modules and module variants to the useful ones. In order to meet this requirement, one would have to continuously update the simulation model within probabilistic evaluation and improvement to accommodate changing properties and

effects. It is suggested to calibrate the simulation model by applying the method and later on comparing the predicted to the actual effects, similar to what has been done in liquid handling case example. If this is done, then there is strong support that this requirement can be fulfilled by using the variant management funnel.

First, all new module and module variants have to safeguard all key properties of the existing modular product family, i.e. its product structure and interfaces. All concepts that are unprofitable because they violate these properties and thus result in adjustments and redesigning of single modules or the entire product family later in the innovation process are discarded or reworked. Second, the remaining concepts are quantitatively evaluated and improved using accepted decision criteria. In evaluation, all stakeholders in the company significantly involved in the innovation process of the new module or module variant are taken into consideration. Uncertainty and risk that are also accounted for in the variant management funnel.

It is concluded here that an implementation and use of the variant management funnel as described in Chapter 4 and keeping in mind the limitations outlined in Subsection 6.4.1 will limit the increase of new module and module variants to the useful ones.

Chapter 7

Summary and Outlook

First, a summary of this work is provided in this chapter. Second, it is described how this work could be expanded on in the scope of future research.

7.1 Summary

In *Chapter 1*, modular product families were identified as one of the most promising approaches for managing complexity in industrial companies. Still, there is no effective variant management in place. Consequently, two research objectives were identified. First, the topic of variant management of modular product families should be academically. Second, a decision support method in this context should be provided.

The first research objective was fulfilled in *Chapter 2*. The research was positioned within design science. In design science, three fields were determined to be relevant for variant management of modular product families in the market phase, namely innovation, variant management, and product structuring. The result of this chapter has been the following definition of variant management of modular product families in the market phase. It is the decision about generating useful new modules and modules variants for an existing modular product family and about preventing unprofitable modules and module variants. Variant management of modular product families in the market phase also includes decisions to reduce the number of modules and module variants and to better handle variety. These aspects are, however, not covered in the proposed method.

The requirements that are to be imposed on a decision support method for variant management of modular product families in the market phase were elaborated on in *Chapter 3*. Such a method must allow the decision maker to safeguard the product structure and interfaces of the existing modular product families. Moreover, it must allow for quantitative evaluation and

improvement of concepts acknowledging uncertainty and risk. The method also has to be efficient in the sense that it is simple to understand, requires a reasonable effort for implementation, and is rapid to use. These requirements are not fulfilled by any method from the literature. The following research question was formulated. *What is an operational method to support decisions in variant management of modular product families in the market phase that allows the decision maker to safeguard the modular product family's key properties as well as to evaluate and improve concepts for new modules and module variants?*

The variant management funnel, which answers the research question and fulfills the second research objective, was proposed in *Chapter 4*. It comprises two screens. In the compatibility screen, it is checked whether concepts for new modules and module variants are compatible with the product structure and interfaces of the existing product family. This is carried out using the framework for modular product families and module sheets. In the stakeholder screen, concepts are evaluated and improved. This is achieved by modeling effects of a new module or module variant using probability distributions, probabilities of occurrence, and conversion rates. In order to provide a concise, yet complete decision basis, the expected value and the CVaR are calculated from the individual effects for each decision criterion. This is done by means of Monte Carlo simulation. The decision maker can compare different concepts quantitatively and choose the most suitable one. The next step is to improve the selected concept by striving to alter the values of properties and observing the impact on the decision criteria.

Two case examples were provided in *Chapter 5*. In the first case example, the variant management funnel was applied to a modular product family of railway signals. In the second case example, the variant management funnel was applied to a family of liquid handling systems.

The variant management funnel was validated using the validation square in *Chapter 6*. First, the structure of the tools and the entire method was validated. Second, it was validated whether the two case examples are suitable and provide a sufficient basis for conclusion. Third, the results from the two case examples were evaluated against the requirements. Finally, the variant management funnel was validated beyond the requirements and two case examples. It was concluded that the variant management funnel will meet the more general requirement of limiting the increase of modules and module variants to useful ones provided that the product family is not too complex and the method is properly applied.

7.2 Outlook

Based on the aspects that could not be treated in the scope of this work, the following avenues for future research are suggested.

- *Broader empirical application:* Two case examples have been presented here. Although these two examples were very different, it would be interesting to see how the variant management funnel performs in different companies and different industries with different products. Since both case examples deal with make-to-order industrial products, it would be particularly valuable to apply the method to more standardized consumer products. This would also allow to check if there are general properties of concepts that have an impact on the successfulness of new modules and module variants. Besides, it would be very useful to observe the long-term impact of a method such as the variant management funnel on the evolution of a modular product family.
- *Analyze impact of statistical dependencies:* Statistical dependencies between effects were not accounted for if no properties were specified for an effect. Once a broader empirical basis is available, it will be possible to measure the inaccuracy that results from neglecting dependencies. This will provide a deeper understanding of the possibilities and limitations of the variant management funnel.
- *Simplifications to facilitate implementation:* Implementing a simulation model using probability distributions and properties can be intricate, especially when there are many properties. That is why it would be useful to carry out research on how to simplify and avoid exponential growth of the number of effects' variants. The accuracy of the simulation model should still be maintained despite such simplifications.

References

- [Afuah, 2003] Afuah, A.: *Innovation Management - Strategies, Implementation, and Profits*. Oxford University Press, New York, NY, 2003.
- [Allen and Carlson-Skalak, 1998] Allen, K.R. and Carlson-Skalak, S.: Defining Product Architecture During Conceptual Design. *Proceedings of ASME 1998 DETC*, Atlanta, GA, 1998.
- [Ambler, 2005] Ambler, S.W.: *The Elements of UML 2.0 Style*. Cambridge University Press, Cambridge, MA, 2005.
- [Andreasen, 1992] Andreasen, M.M.: Designing on a Designer's Workbench. *Proceedings of 9th WDK Workshop*, Rigi, Switzerland, 1992.
- [Andreasen et al., 2004] Andreasen, M.M., Mortensen, N.H. and Harlou, U.: Multi Product Development: New Models and Concepts. *Proceedings of 15th Symposium Design For X*, Neukirchen, Germany, 2004.
- [Baldwin and Clark, 1997] Baldwin, C.Y. and Clark, K.B.: Managing in an Age of Modularity. *Harvard Business Review*, Vol. 75 (5), 1997, pp. 84-93.
- [Baldwin and Clark, 2000] Baldwin, C.Y. and Clark, K.B.: *Design Rules - The Power of Modularity*. MIT Press, Cambridge, MA, 2000.
- [Bayus, 1994] Bayus, B.L.: Are Product Life Cycles Really Getting Shorter? *Journal of Product Innovation Management*, Vol. 11 (4), 1994, pp. 300-308.

- [Bircher, 2005] Bircher, M.: *Die integrale Produktinnovation - Ein Ansatz zur Unterstützung von Innovationsprojekten*. Ph.D. thesis, ETH Zurich, Zurich, 2005.
- [Blackenfelt, 2000] Blackenfelt, M.: *Modularisation by Relational Matrices - A Method for the Consideration of Strategic and Functional Aspects*. *Proceedings of 5th WDK Workshop on Product Structuring*, Tampere, Finland, 2000.
- [Blackenfelt, 2001] Blackenfelt, M.: *Managing Complexity by Product Modularisation*. Ph.D. thesis, Royal Institute of Technology, Stockholm, 2001.
- [Blanchard, 1998] Blanchard, B.S.: *System Engineering Management*. John Wiley & Sons, New York, NY, 1998.
- [Bleicher, 2004] Bleicher, K.: *Das Konzept Integriertes Management: Visionen - Missionen - Programme*. Campus, Frankfurt, 2004.
- [Blyler, 2004] Blyler, J.: *Interface Management*. *IEEE Measurement & Instrumentation Magazine*, Vol. 7 (1), 2004, pp. 32-37.
- [Browning, 2001] Browning, T.R.: *Applying the Design Structure Matrix to System Decomposition and Integration Problems - A Review and New Directions*. *IEEE Transactions on Engineering Management*, Vol. 48 (3), 2001, pp. 292-306.
- [Caesar, 1991] Caesar, C.: *Kostenorientierte Gestaltungsmethodik für variantenreiche Serienprodukte - Variant Mode and Effects Analysis (VMEA)*. VDI Verlag, Düsseldorf, 1991.
- [Chen and Liu, 2005] Chen, K.-C. and Liu, R.-J.: *Interface Strategies in Modular Product Innovation*. *Technovation*, Vol. 25 (1), 2005, pp. 771-782.

- [Child et al., 1991] Child, P., Diederichs, R., Sanders, F.H. and Wisniowski, S.: The Management of Complexity. *Sloan Management Review*, Vol. 33 (1), 1991, pp. 73-80.
- [Clark and Wheelwright, 1993] Clark, K.B. and Wheelwright, S.C.: *Managing New Product and Process Development*. Harvard Business School Press, Boston, MA, 1993.
- [Cooper, 2002] Cooper, R.G.: *Top oder Flop in der Produktentwicklung: Erfolgsstrategien - Von der Idee zum Launch*. John Wiley & Sons, Weinheim, 2002.
- [Daenzer and Büchel, 1986] Daenzer, W.F. and Büchel, A.: *Systems Engineering - Leitfaden zur methodischen Durchführung umfangreicher Planungsvorhaben*. Industrielle Organisation, Zurich, 1986.
- [Dieter, 1991] Dieter, G.E.: *Engineering Design: A Materials and Processing Approach*. McGraw-Hill, New York, NY, 1991.
- [DIN199-1, 2002] DIN199-1: *Technical Product Documentation - CAD-Models, Drawings and Items Lists - Part 1: Vocabulary*. Beuth-Verlag, 2002.
- [Dubi, 2000] Dubi, A.: *Monte Carlo Applications in Systems Engineering*. John Wiley & Sons, Chichester, 2000.
- [Ehrlenspiel, 1995] Ehrlenspiel, K.: *Integrierte Produktentwicklung - Methoden für Prozessorganisation, Produkterstellung und Konstruktion*. Hanser, Munich, 1995.
- [Erens, 1996] Erens, F.-J.: *The Synthesis of Variety - Developing Product Families*. Ph.D. thesis, Eindhoven University of Technology, Eindhoven, 1996.

- [Ericsson and Erixon, 1999] Ericsson, A. and Erixon, G.: *Controlling Design Variants - Modular Product Platforms*. Society of Manufacturing Engineers, Dearborn, MI, 1999.
- [Erixon, 1998] Erixon, G.: *Modular Function Deployment - A Method for Product Modularisation*. Ph.D. thesis, Royal Institute of Technology, Stockholm, 1998.
- [Feitzinger and Lee, 1997] Feitzinger, E. and Lee, H.L.: Mass Customization at Hewlett-Packard - The Power of Postponement. *Harvard Business Review*, Vol. 75 (1), 1997, pp. 116-121.
- [Fernández et al., 2001] Fernández, M.G., Seepersad, C.C., Rosen, D.W., Allen, J.K. and Mistree, F.: Utility-Based Decision Support for Selection in Engineering Design. *Proceedings of ASME DETC 2001*, Pittsburgh, PA, 2001.
- [Franke et al., 2002] Franke, H.-J., Hesselbach, J., Huch, B. and Firchau, N.L.: *Variantenmanagement in der Einzel- und Kleinserienfertigung*. Hanser, Munich, 2002.
- [Friedrich, 2004] Friedrich, T.: *Strategische Produktprogrammplanung bei variantenreichen Produkten*. Ph.D. thesis, University of St. Gallen, St. Gallen, 2004.
- [Gemünden, 1993] Gemünden, H.-G.: Zeit - Strategischer Erfolgsfaktor in Innovationsprozessen. *F&E Management*. M. Domsch et al. Schäffer-Poeschel, Stuttgart, 1993, pp. 67-118.
- [Gershenson et al., 2003] Gershenson, J.K., Prasad, G.J. and Zhang, Y.: Product Modularity: Definitions and Benefits. *Journal of Engineering Design*, Vol. 14 (3), 2003, pp. 295-313.
- [Göpfert, 1998] Göpfert, J.: *Modulare Produktentwicklung zur gemeinsamen Gestaltung von Technik und Organisation*. Deutscher Universitäts-Verlag, Wiesbaden, 1998.

- [Green and Krieger, 1985] Green, P.E. and Krieger, A.M.: Models and Heuristics for Product Line Selection. *Marketing Science*, Vol. 4 (1), 1985, pp. 1-19.
- [Gut, 2005] Gut, A.: *Probability - A Graduate Course*. Springer, New York, NY, 2005.
- [Hauschildt, 2005] Hauschildt, J.: *Innovationsmanagement*. Vahlen, Munich, 2004.
- [Hazelrigg, 1998] Hazelrigg, G.A.: A Framework for Decision-Based Engineering Design. *ASME Journal of Mechanical Design*, Vol. 120 (4), 1998, pp. 653-658.
- [Heina, 1999] Heina, J.: *Variantenmanagement: Kosten-Nutzen-Bewertung zur Optimierung der Variantenvielfalt*. Deutscher Universitäts-Verlag, Wiesbaden, 1999.
- [Henderson and Clark, 1990] Henderson, R.M. and Clark, K.B.: Architectural Innovation: The Reconfiguration of Existing Product Technologies and the Failure of Established Firms. *Administrative Science Quarterly*, Vol. 35 (1), 1990, pp. 9-30.
- [Hichert, 1985] Hichert, R.: Probleme der Vielfalt. Teil 1: Soll man auf Exoten verzichten? *wt - Zeitschrift für industrielle Fertigung*, Vol. 75 (1), 1985, pp. 235-237.
- [Hill and Rieser, 1993] Hill, W. and Rieser, I.: *Marketing-Management*. Haupt, Berne, 1993.
- [Hirtz et al., 2002] Hirtz, J., Stone, R.D., McAdams, D.A., Szykman, S. and Wood, K.L.: A Functional Basis for Engineering Design: Reconciling and Evolving Previous Efforts. *Research in Engineering Design*, Vol. 13 (2), 2002, pp. 65-82.

- [Holtzman, 1989] Holtzman, S.: *Intelligent Decision Systems*. Addison-Wesley, Reading, MA, 1989.
- [Homburg and Daum, 1997] Homburg, C. and Daum, D.: Wege aus der Komplexitätsfalle. *ZWF*, Vol. 92 (7-8), 1997, pp. 333-335.
- [Hubka and Eder, 1996] Hubka, V. and Eder, W.E.: *Design Science: Introduction to Needs, Scope and Organization of Engineering Design Knowledge*. Springer, London, 1996.
- [ISO10303-11, 2004] ISO10303-11: *Industrial Automation Systems and Integration - Product Data Representation and Exchange - Part 11: Description Methods: The EXPRESS Language Reference Manual*. I.I.O.f. Standardization, 2004.
- [Jiao, 1998] Jiao, J.: *Design for Mass Customization by Developing Product Family Architecture*. Ph.D. thesis, Hong Kong University of Science and Technology, Hong Kong, 1998.
- [Jondral and Wiesler, 2000] Jondral, F. and Wiesler, A.: *Grundlagen der Wahrscheinlichkeitsrechnung und stochastischer Prozesse für Ingenieure*. B.G. Teubner, Stuttgart, 2000.
- [Junge, 2005] Junge, M.: *Controlling modularer Produktfamilien in der Automobilindustrie: Entwicklung und Anwendung der Modularisierungs-Balanced-Scorecard*. Deutscher Universitäts-Verlag, Wiesbaden, 2005.
- [Kähler et al., 1983] Kähler, S., Lund, T. and Andreasen, M.M.: *Design for Assembly*. IFS Publications, Berlin, 1983.
- [Kaiser, 1995] Kaiser, A.: *Integriertes Variantenmanagement mit Hilfe der Prozesskostenrechnung*. Ph.D. thesis, University of St. Gallen, St. Gallen, 1995.

- [Kaplan and Norton, 1996] Kaplan, R.S. and Norton, D.P.: *The Balanced Scorecard: Translating Strategy into Action*. Harvard Business School Press, Boston, MA, 1996.
- [Karandikar and Mistree, 1993] Karandikar, H.M. and Mistree, F.: Modeling Concurrency in the Design of Composite Structures. *Structural Optimization: Status and Promise*. M.P. Kamat. American Institute of Aeronautics and Astronautics, Washington, DC, 1993, pp. 251-286.
- [Keeney and Raiffa, 1976] Keeney, R.L. and Raiffa, H.: *Decisions with Multiple Objectives Preferences and Value Tradeoffs*. John Wiley & Sons, New York, NY, 1976.
- [Kerzner, 2003] Kerzner, H.: *Projektmanagement - Ein systemorientierter Ansatz zur Planung und Steuerung*. mitp, Bonn, 2003.
- [Kimberly, 1999] Kimberly, W.: Back to the Future. *Automotive Engineer*, Vol. 24 (5), 1999, pp. 62-64.
- [Koller, 2005] Koller, J.: *Einsatz des Conditional Value-at-Risk in der Entscheidung unter Risiko - Anwendungen in der Portfolioabsicherung*. Ph.D. thesis, University of St. Gallen, St. Gallen, 2005.
- [Koller, 1998] Koller, R.: *Konstruktionslehre für den Maschinenbau - Grundlagen zur Neu- und Weiterentwicklung technischer Produkte mit Beispielen*. Springer, Berlin, 1998.
- [Kotler, 2003] Kotler, P.: *Marketing-Management*. Prentice Hall, Upper Saddle River, NJ, 2003.
- [Kunz, 2005] Kunz, A.: *Planung variantenreicher Produkte*. Ph.D. thesis, ETH Zurich, Zurich, 2005.

- [Kunz et al. 2004] Kunz, A., Sekolec, R. and Meier, M.: Definition and Description of Variability in Conceptual Design of Modular Product Families. *Proceedings of DESIGN 2004*, Dubrovnik, Croatia, 2004.
- [Li and Azarm, 2000] Li, H. and Azarm, S.: Product Design Selection under Uncertainty and with Competitive Advantage. *Journal of Mechanical Design*, Vol. 133 (1), 2000, pp. 411-418.
- [Magrab, 1997] Magrab, E.B.: *Integrated Product and Process design and Development: The Product Realization Process*. CRC Press, Boca Raton, FL, 1997.
- [Malik, 1996] Malik, F.: *Strategie des Managements komplexer Systeme - Ein Beitrag zur Management-Kybernetik evolutionärer Systeme*. Haupt, Berne, 1996.
- [Malmqvist, 2002] Malmqvist, J.: A Classification of Matrix-Based Methods for Product Modeling. *Proceedings of DESIGN 2002*, Dubrovnik, Croatia, 2002.
- [Männistö et al., 1999] Männistö, T., Peltonen, H., Martio, A. and Sulonen, R.: Modeling Generic Product Structures in STEP. *Computer-Aided Design*, Vol. 30 (14), 1999, pp. 1111-1118.
- [Marston and Mistree, 1998] Martston, M. and Mistree, F.: An Implementation of Utility Theory in Decision Based Design. *Proceedings of ASME 1998 DETC*, Atlanta, GA, 1998.
- [Matern, 2000] Matern, C.: *Systemwirtschaftliches Variantenmanagement - Operationalisierung und Quantifizierung des integrierten Variantenmanagements*. Vandenhoeck & Ruprecht, Göttingen, 2000.

- [Mattson and Messac, 2005] Mattson, C.A. and Messac, A.: Pareto Frontier Based Concept Under Uncertainty, with Visualization. *Optimization and Engineering*, Vol. 6 (1), 2005, pp. 85-115.
- [Mesihovic and Malmqvist, 2004] Mesihovic, S. and Malmqvist, J.: A Process-Oriented Approach for Management of Product Configuration Models. *Proceedings of ASME 2004 DETC*, Salt Lake City, UT, 2004.
- [Meyer and Lehnerd, 1997] Meyer, M.H. and Lehnerd, A.P.: *The Power of Product Platforms - Building Value and Cost Leadership*. Free Press, New York, NY, 1997.
- [Meyer et al., 1997] Meyer, M.H., Tertzakian, P. and Utterback, J.M.: Metrics for Managing Research and Development in the Context of the Product Family. *Management Science*, Vol. 43 (1), 1997, pp. 88-111.
- [Mitterdorfer-Schaad, 2001] Mitterdorfer-Schaad, D.D.: *Modellierung unternehmensspezifischer Innovations-Prozessmodelle*. Ph.D. thesis, ETH Zurich, Zurich, 2001.
- [Montau, 1996] Montau, R.: *Föderatives Produktdatenmanagement anhand semantischer Informationsmodellierung*. VDI Verlag, Düsseldorf, 1996.
- [Morgenstern and Neumann, 1947] Morgenstern, O. and Neumann, J.v.: *Theory of Games and Economic Behavior*. Princeton University Press, Princeton, NJ, 1947.
- [Mortensen et al., 2000] Mortensen, N.H., Yu, B., Skovgard, H.J. and Harlou, U.: Conceptual Modeling of Product Families in Configuration Projects. *Proceedings of 4th European Conference on Artificial Intelligence*, Berlin, Germany, 2000.

- [Muffatto, 1999] Muffatto, M.: Introducing a Platform Strategy in Product Development. *International Journal of Production Economics*, Vol. 60-61 (1), 1999, pp. 145-153.
- [Muffatto and Roveda, 2002] Muffatto, M. and Roveda, M.: Product Architecture and Platforms: A Conceptual Framework. *International Journal of Technology Management*, Vol. 24 (1), 2002, pp. 1-16.
- [Müller, 2000] Müller, M.: *Management der Entwicklung von Produktplattformen*. Ph.D. thesis, University of St. Gallen, St. Gallen, 2000.
- [Mullur et al., 2003] Mullur, A.A., Mattson, C.A. and Messac, A.: Pitfalls of the Typical Construction of Decision Matrices for Concept Selection. *Proceedings of 41st AIAA Aerospace Sciences Meeting*, Reno, NV, 2003.
- [Oestereich, 2005] Oestereich, B.: *Analyse und Design mit UML 2 - Objektorientierte Softwareentwicklung*. Oldenbourg, Munich, 2005.
- [Olewnik and Lewis, 2003] Olewnik, A.T. and Lewis, K.E.: On Validating Design Decision Methodologies. *Proceedings of ASME 2000 DETC*, Chicago, IL, 2003.
- [Oliver et al., 1997] Oliver, D.W., Kelliher, T.P. and Keegan, J.G.: *Engineering Complex Systems with Models and Objects*. McGraw-Hill, New York, NY, 1997.
- [Otto and Wood, 2001] Otto, K.N. and Wood, K.L.: *Product Design - Techniques in Reverse Engineering and New Product Development*. Prentice Hall, Upper Saddle River, NJ, 2001.
- [Paashuis, 1998] Paashuis, V.: *The Organisation of Integrated Product Development*. Springer, London, 1998.

- [Pahl and Beitz, 1996] Pahl, G. and Beitz, W.: *Engineering Design - A Systematic Approach*. Springer, London, 1996.
- [Pedersen et al., 2000] Pedersen, K., Emblemståg, J., Bailey, R., Allen, J.K. and Mistree, F.: Validating Design Methods & Research: The Validation Square. *Proceedings of ASME 2000 DETC*, Baltimore, MD, 2000.
- [Pflug, 2000] Pflug, G.C.: Some Remarks on the Value-at-Risk and the Conditional Value-at-Risk. *Probabilistic Constrained Optimization: Methodology and Applications*. S. Uryasev. Kluwer, Dordrecht, 2000, pp. 272-281.
- [Piller, 2001] Piller, F.T.: *Mass Customization - Ein wettbewerbsstrategisches Konzept im Informationszeitalter*. Deutscher Universitäts-Verlag, Wiesbaden, 2001.
- [Pimmler and Eppinger, 1994] Pimmler, T.U. and Eppinger, S.D.: Integration Analysis of Product Decompositions. *Proceedings of ASME Design Theory and Methodology Conference*, Minneapolis, MN, 1994.
- [Pleschak and Sabisch, 1996] Pleschak, F. and Sabisch, H.: *Innovationsmanagement*. Schäffer-Poeschel, Stuttgart, 1996.
- [Poole and Simon, 1997] Poole, S. and Simon, M.: Technological Trends, Product Design and the Environment. *Design Studies*, Vol. 18 (3), 1997, pp. 237-248.
- [Popper, 1979] Popper, K.R.: Die Logik der Sozialwissenschaften. *Der Positivismusstreit in der deutschen Soziologie*. T.W. Adorno. Luchterhand Verlag, Darmstadt, 1979, pp. 103-123.

- [Preiss et al., 2006] Preiss, M., Avak, B. and Imelli, P.: Industrial Relevance of Design Science - An Empirical Study. *Proceedings of DESIGN 2006*, Dubrovnik, Croatia, 2006.
- [Puhl, 1999] Puhl, H.: *Komplexitätsmanagement - Ein Konzept zur ganzheitlichen Erfassung, Planung und Regelung der Komplexität in Unternehmensprozessen*. Ph.D. thesis, University of Kaiserslautern, Kaiserslautern, 1999.
- [Puls, 2003] Puls, C.: *Die Konfigurations- & Verträglichkeitsmatrix als Beitrag zum Management von Konfigurationswissen in KMU*. VDI Verlag, Düsseldorf, 2003.
- [Rainey, 2004] Rainey, D.L.: *Product Innovation - Leading Change Through Integrated Product Development*. Cambridge University Press, New York, NY, 2004.
- [Rapp, 1999] Rapp, T.: *Produktstrukturierung - Komplexitätsmanagement durch modulare Produktstrukturen und -plattformen*. Gabler, Wiesbaden, 1999.
- [Rathnow, 1993] Rathnow, P.J.: *Integriertes Variantenmanagement - Bestimmung, Realisierung und Sicherung der optimalen Produktvielfalt*. Vandenhoeck & Ruprecht, Göttingen, 1993.
- [Rice, 1995] Rice, J.A.: *Mathematical Statistics and Data Analysis*. Duxbury Press, Belmont, CA, 1995.
- [Robertson and Ulrich, 1998] Robertson, D. and Ulrich, K.: Planning for Product Platforms. *Sloan Management Review*, Vol. 39 (4), 1998, pp. 19-31.
- [Rockafellar and Uryasev, 2001] Rockafellar, R.T. and Uryasev, S.: Optimization of Conditional Value-at-Risk. *Journal of Risk*, Vol. 2 (3), 2001, pp. 21-41.

- [Rommel, 1993] Rommel, G.: *Einfach Überlegen - Das Unternehmenskonzept, das die Schlanken schlank und die Schnellen schnell macht*. Schäffer-Poeschel, Stuttgart, 1993.
- [Roozenburg and Eekels, 1995] Roozenburg, N.F.M. and Eekels, J.: *Product Design: Fundamentals and Methods*. John Wiley & Sons, Chichester, 1995.
- [Rudberg and Wikner, 2004] Rudberg, M. and Wikner, J.: Mass Customization in Terms of the Customer Order Decoupling Point. *Production Planning & Control*, Vol. 15 (4), 2004, pp. 445-458.
- [Rumbaugh et al., 1991] Rumbaugh, J., Blaha, M., Premerlani, W.J., Eddy, F. and Lorensen, W.: *Object-Oriented Modeling and Design*. Prentice-Hall, Englewood Cliffs, NJ, 1991.
- [Schuh, 1989] Schuh, G.: *Gestaltung und Bewertung von Produktvarianten - Ein Beitrag zur systematischen Planung von Serienprodukten*. VDI Verlag, Düsseldorf, 1989.
- [Schuh, 2005] Schuh, G.: *Produktkomplexität managen: Strategien - Methoden - Tools*. Hanser, Munich, 2005.
- [Schuh and Jonas, 1997] Schuh, G. and Jonas, I.: *Variantenreduzierung im Verbund - Praktikable Methode zum Variantenmanagement: Ein Leitfaden zur Beherrschung der Variantenvielfalt*. ViA Verbundinitiative Automobil Nordrhein-Westfalen, Düsseldorf, 1997.
- [Schuh and Tanner, 1998] Schuh, G. and Tanner, H.R.: Mastering Variant Variety Using the Variant Mode and Effects Analysis. *Proceedings of ASME 1998 DETC*, Atlanta, GA, 1998.
- [Sekolec, 2005] Sekolec, R.: *Produktstrukturierung als Instrument des Variantenmanagements in der methodischen Entwicklung modularer Produktfamilien*. VDI Verlag, Düsseldorf, 2005.

- [Simon, 1996] Simon, H.A.: *Sciences of the Artificial*. MIT Press, Cambridge, MA, 1996.
- [Simpson, 2003] Simpson, T.W.: Product Platform Design and Optimization: Status and Promise. *Proceedings of ASME 2003 DETC*, Chicago, IL, 2003.
- [Simpson, 2004] Simpson, T.W.: Product Platform Design and Customization: Status and Promise. *Artificial Intelligence for Engineering Design, Analysis and Manufacturing*, Vol. 18 (1), 2004, pp. 3-20.
- [Sivard, 2000] Sivard, G.: *A Generic Information Platform for Product Families*. Ph.D. thesis, Royal Institute of Technology, Stockholm, 2000.
- [Stalk and Hout, 1990] Stalk, G. and Hout, T.M.: *Competing Against Time - How Time-Based Competition is Reshaping Global Markets*. FP The Free Press, New York, NY, 1990.
- [Sudjianto and Otto, 2001] Sudjianto, A. and Otto, K.N.: Modularization to Support Multiple Brand Platforms. *Proceedings of ASME 2001 DETC*, Pittsburgh, PA, 2001.
- [Suh, 1990] Suh, N.P.: *The Principles of Design*. Oxford University Press, New York, NY, 1990.
- [Suh, 2001] Suh, N.P.: *Axiomatic Design: Advances and Applications*. Oxford, New York, NY, 2001.
- [Sundgren, 1999] Sundgren, N.: Introducing Interface Management in New Product Family Development. *Journal of Product Innovation Management*, Vol. 16 (1), 1999, pp. 40-51.

- [Tatikonda, 1999] Tatikonda, M.V.: An Empirical Study of Platform and Derivative Product Development Projects. *Journal of Product Innovation Management*, Vol. 16 (1), 1999, pp. 3-26.
- [Tiihonen et al., 1998] Tiihonen, J., Lehtonen, T., Soininen, T., Pulkkinen, A., Sulonen, R. and Riitahuhta, A.: Modeling Configurable Product Families. *Proceedings of 4th WDK Workshop on Product Structuring*, Delft, Netherlands, 1998.
- [Tittmann, 2000] Tittmann, P.: *Einführung in die Kombinatorik*. Spektrum Akademischer Verlag, Heidelberg, 2000.
- [Tschirky, 1998] Tschirky, H.P.: *Technologie-Management: Idee und Praxis*. Verlag Industrielle Organisation, Zurich, 1998.
- [Ullman, 2003] Ullman, D.G.: *The Mechanical Design Process*. McGraw-Hill, Boston, MA, 2003.
- [Ulrich, 1984] Ulrich, H.: *Management*. Haupt, Berne, 1984.
- [Ulrich, 1995] Ulrich, K.: The Role of Product Architecture in the Manufacturing Firm. *Research Policy*, Vol. 24 (4), 1995, pp. 419-440.
- [Ulrich and Tung, 1991] Ulrich, K. and Tung, K.: Fundamentals of Product Modularity. *Issues in Design/Manufacture Integration*, Vol. DE-39 (1), 1991, pp. 73-79.
- [Ulrich and Eppinger, 2003] Ulrich, K.T. and Eppinger, S.D.: *Product Design and Development*. McGraw-Hill, New York, NY, 2003.
- [Uzumeri and Sanderson, 1995] Uzumeri, M. and Sanderson, S.: A Framework for Model and Product Family Competition. *Research Policy*, Vol. 24 (1), 1995, pp. 583-607.

- [VDI2222-1, 1997] VDI2222-1: *Konstruktionsmethodik - Methodisches Entwickeln von Lösungsprinzipien*. Beuth-Verlag, 1997.
- [VDI2221, 1990] VDI2221: *Methodik zum Entwickeln und Konstruieren technischer Systeme und Produkte*. Beuth-Verlag, 1990.
- [VDI2225, 1998] VDI2225: *Konstruktionsmethodik - Technisch-wirtschaftliches Konstruieren - Technisch-wirtschaftliche Bewertung*. Beuth-Verlag, 1998.
- [Veen, 1992] Veen, E.A.v.: *Modelling Product Structures by Generic Bills-of-Materials*. Elsevier, Amsterdam, 1992.
- [Wheelwright and Clark, 1992] Wheelwright, S.C. and Clark, K.B.: *Revolutionizing Product Development Quantum Leaps in Speed, Efficiency and Quality*. Free Press, New York, NY, 1992.
- [Wiendahl, 2004] Wiendahl, H.-P.: *Variantenbeherrschung in der Montage - Konzept und Praxis der flexiblen Produktionsstufe*. Springer, Berlin, 2004.
- [Wilhelm, 1997] Wilhelm, B.: Platform and Modular Concepts at Volkswagen - Their Effects on the Assembly Process. *Experience in Automation and Work Organization*. K. Shimokawa et al., Springer, 1997, pp. 146-156.
- [Wüpping, 1992] Wüpping, J.: *Systematische Entwicklung und Nutzung von Baukastensystemen für Wrap-around-Verpackungsmaschinen*. Deutscher Fachverlag, Frankfurt, 1992.
- [Yin, 1994] Yin, R.K.: *Case Study Research Design and Methods*. SAGE, Thousand Oaks, CA, 1994.
- [Zwicky, 1989] Zwicky, F.: *Entdecken, Erfinden, Forschen im morphologischen Weltbild*. Baeschlin, Glarus, 1989.

Curriculum Vitae

Personal Data

Name: Björn Avak
Date of birth: April 17, 1980
Place of birth: Berlin, Germany
Nationality: German

Education

2004 - 2006 *ETH Zurich, Switzerland*
Doctoral studies
2003 - 2004 *Georgia Institute of Technology, Atlanta, USA*
Studies of Electrical and Computer Engineering
Master of Science
2000 - 2003 *University of Karlsruhe, Germany*
Studies of Electrical and Computer Engineering
1990 - 1999 *Pestalozzi-Gymnasium, Biberach, Germany*
High School
Abitur

Work Experience

2004 - 2006 *ETH Zurich, Switzerland*
Research assistant
2003 *DaimlerChrysler AG, Stuttgart, Germany*
Internship
1999 *Liebherr Home Appliances, Ochsenhausen, Germany*
Internship