

OVERVIEW OF GCOM

IGARSS11

Vancouver, Canada

July29,2011

Haruhisa Shimoda, Hiroshi Murakami

Taikan Oki, Yoshiaki Honda,

Tamotsu Igarashi

EORC, JAXA

Background

- **Minister of MEXT committed at Earth Observation Summit on Apr. 2004**
 - **Global Warming, Carbon Cycle**
 - **Climate Change, Water Cycle**
 - **Disaster mitigation**
 - **Future Earth Observation system must reflect**
 - **Reliability**
 - **Continuity**
 - **User oriented**
 - **“Stable and continuous social infrastructure”**
- Contribution to GEOSS**

Council for Science and Technology Policy (CSTP)

- 3rd Science and Technology Basic Plan
- Total budget of \$240B in 5 years
- Strategic fields : Environment, Life science, Information/communication, Nano-technology
- Ocean-Earth Observation Exploration System
- One of the 5 national critical technology

GEOSS 10 year implementation plan



Earth System Model

- Ocean
- Cryosphere
- Land
- Atmosphere
- Solid Earth
- Biosphere

Prediction & Analysis
 High speed computing & communication
 Visualization

Other data
 Socio-economic data

Assimilation

Earth observation system

- In-situ observation
- Airborne observation
- Satellite observation

Interoperability criterion
Observation

Essential Climate Variables (ECV)
 Require continuous satellite products

Policy decision support

- Evaluation
- Decision support system

Policy decision



9 Societal benefit areas



Value optimization, Elimination of gap areas,
 Continuous feedback for human activity understanding

JAXA's Long-Term Plan of Earth Observation

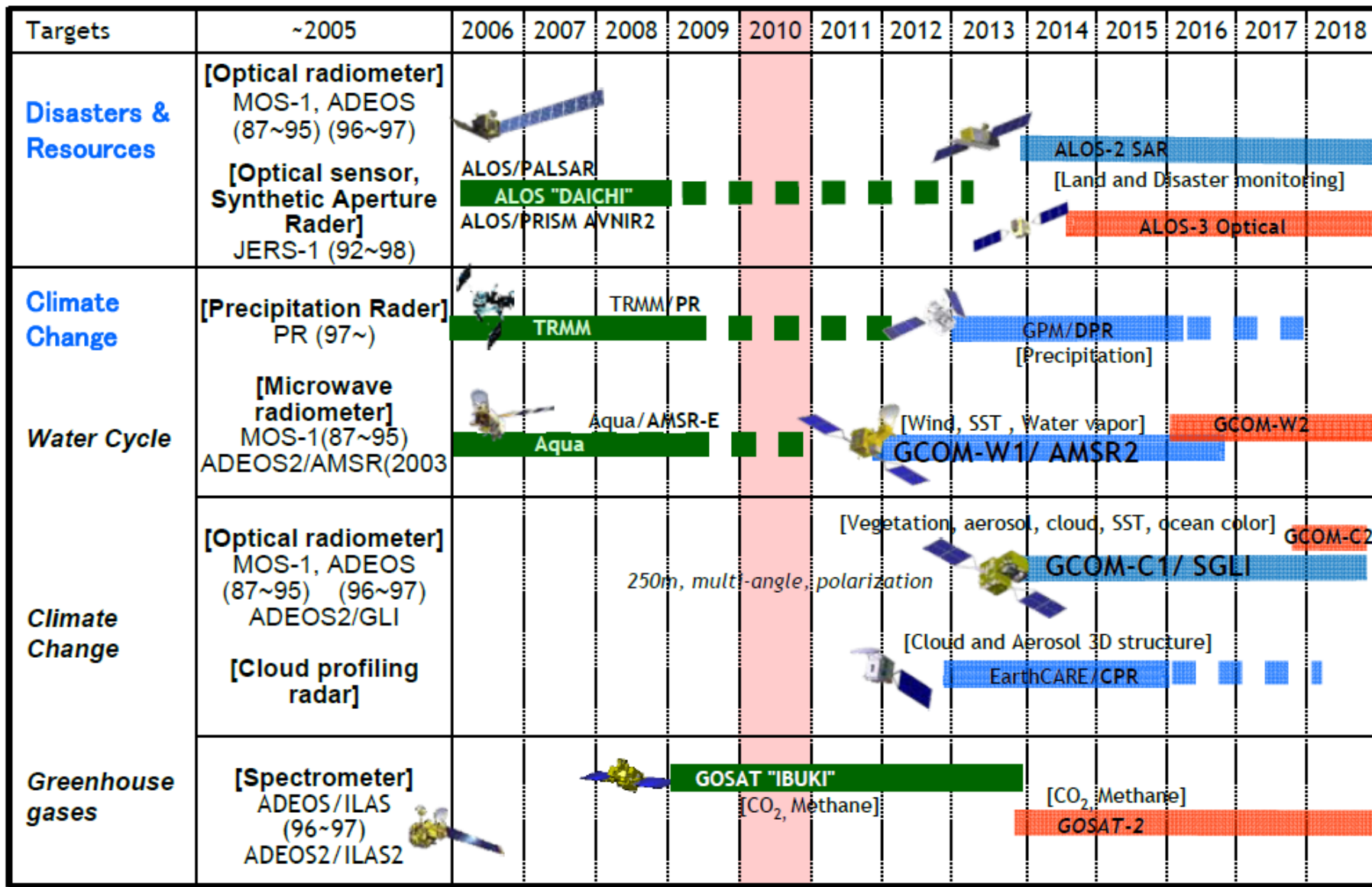

Mission status ■ On orbit ■ Phase B~ ■ Phase A ■ Extension

JAXA Future Environment Missions

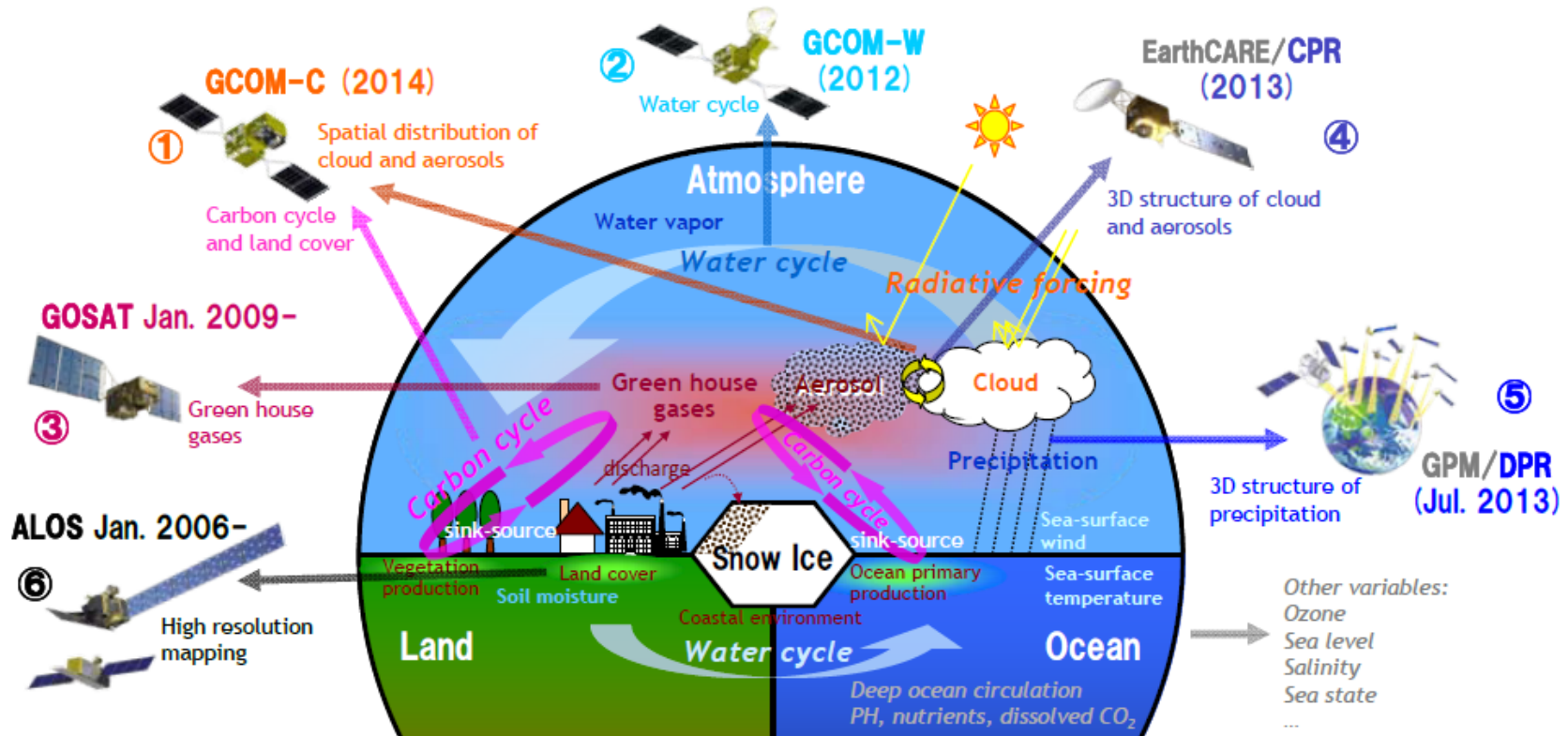

- ① GCOM-C:** Long-term observation of the horizontal distribution of aerosol, cloud, and ecosystem CO₂ absorption and discharge
- ② GCOM-W:** Long-term observation of water-cycle such as the snow/ice coverage, water vapor, and SST
- ③ GOSAT:** Observation of distribution and flux of the atmospheric greenhouse gases, CO₂ and CH₄
- ④ EarthCARE/CPR:** Observation of vertical structure of clouds and aerosols
- ⑤ GPM/DPR:** Accurate and frequent observation of precipitation with active and passive sensors
- ⑥ ALOS:** Fine resolution mapping by optical and SAR instruments

GCOM Mission

- **Continuation of ADEOS II**
- **Contribution to GEOSS**
- **Climate, Weather, Water, Ecosystem, Agriculture, etc. in GEOSS 9 areas**
- **Focus on Climate change / Global warming and Water cycle committed in Summit**
- **Contribution to operational fields like weather forecast, fisheries, etc.**
- **Long term continuous measurements**

Scientific Targets

- **Accurate estimation of aerosol radiative forcing**
- **Validation of climate models**
- **Accurate estimation of primary production**
- **Better understanding of coastal phenomena**
- **Better understanding of sea ice trend**

GCOM Observation Targets

Radiation budget

Cloud/aerosol changes
and Radiative forcing

Ice-albedo
feedback

Major unknown factor
in climate modeling

Carbon cycle

Carbon cycle and
vegetation production

Carbon and heat pool
and coastal
environment

Sink and pool of CO₂
(major greenhouse gas)

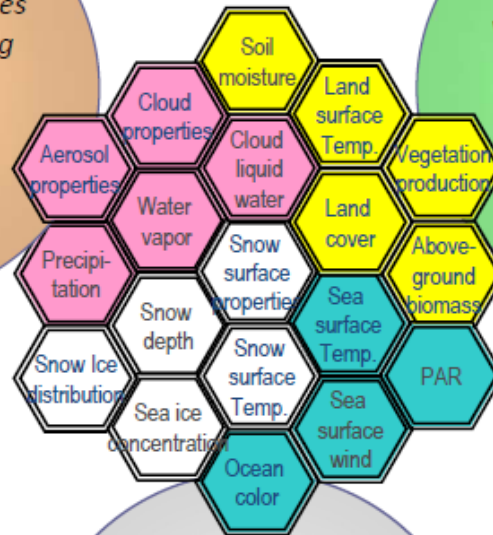

Water and energy
cycle in global scale

Water cycle changes
by global warming

Direct effect to
human activities
(severe weather, flood,
water resources)

Water/Energy cycle

Operational Applications

- **Input to NWP**
- **Extreme weather forecasting**
- **Fisheries**
- **Navigation**
- **Coastal management**
- **Crop yield estimation**
- **Monitoring forest decrease**
- **Monitoring volcano eruptions**
- **Monitoring forest fire**

GCOM satellites

- **GCOM-W1**
 - AMSR2 (Advanced Microwave Scanning Radiometer 2)
 - Planned to be launched on Feb., 2012
- **GCOM-C1**
 - SGLI (Second generation Global Imager)
 - Planned to be launched in fiscal 2014
- **Plan for the 2nd and 3rd generations**
 - GCOM-W2 (in 2015), GCOM-W3 (in 2019)
 - GCOM-C2 (in 2018), GCOM-C3 (in 2022)



GCOM-W1

- Orbit
 - Sun synchronous orbit
 - Height: about 700km
 - Local time of ascending node: 13:30
- Weight: about 1.99t
- Power : about 3.9kW
- Lifetime: 5 years
- Data transmission
 - Global observation data are stored and transmitted every orbit period
 - Observed data are transmitted to ground stations in real time

A-Train and GCOM-W1

- After invitation to A-Train constellation from NASA, JAXA and A-Train members studied the possibility of participation of GCOM-W1 to A-Train.
- Participation of GCOM-W1 to A-Train was approved by A-Train members last October. The position of GCOM-W1 is ahead of Aqua.
- Benefits of joining the A-train are:
 - Precise inter-calibration between AMSR-E and AMSR2; and
 - Synergy with A-Train instruments for new Earth science research.

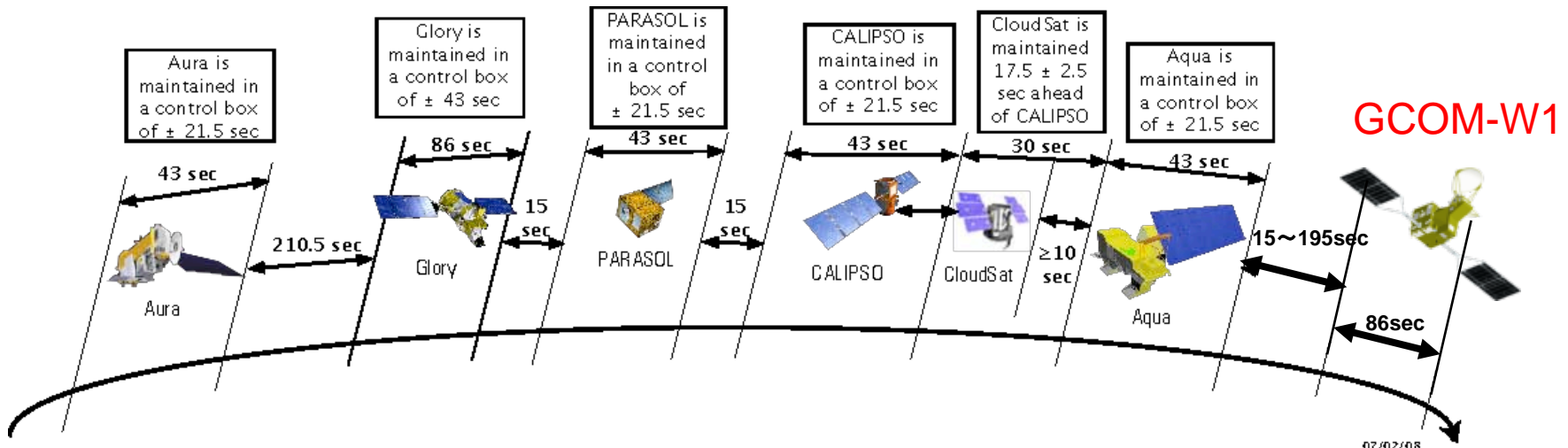

Downlink

- Freq : 8245MHz
- Polarization : RHCP
- Modulation : OQPSK
- Data Rate : 10Mbps (20Msps)
- Coding : CCSDS, Reed-Solomon, convolution

GCOM-W/1 satellite

GCOM-W (Water)

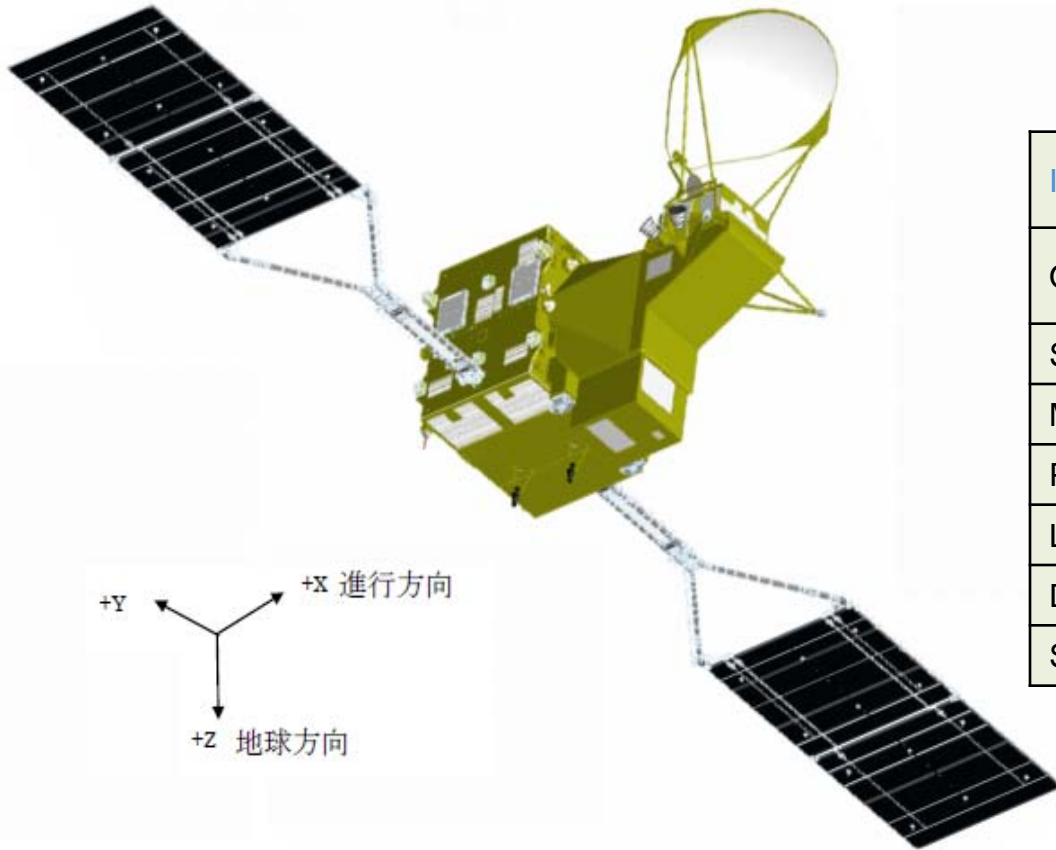

Instrument	Advanced Microwave Scanning Radiometer-2
Orbit	Sun Synchronous orbit Altitude: 699.6km (over the equator)
Size	5.1m (X) * 17.5m (Y) * 3.4m (Z)
Mass	1880kg
Power	Over 4050W
Launch	JFY2011 (CY2012 Winter)
Design Life	5-years
Status	Preliminary Design started in JFY2007

- *GCOM-W1/AMSR2 will contribute to long-term observation of global water and energy cycle.*
- *Continue AMSR-E observation (high spatial resolution, low-frequency channels, etc.).*
- *Construct reliable long-term dataset to contribute for understanding and monitoring of climate change.*
- *Contribute to operational use by providing continuous cloud-through SST, frequent and quantitative storm observation to maintain precipitation forecast accuracy.*

Basic requirements for AMSR 2

- Minimum modifications from AMSR on ADEOS-II to reduce risks/cost and keep the earliest launch date.
- Several essential improvements.
 - Improvement of calibration system including warm load calibration target.
 - Consideration to C-band radio frequency interference (RFI).
- Combination with SeaWinds-type scatterometer is **highly desired**.

Basic requirements for AMSR 2

- Antenna : 2.0m, offset parabolic antenna
- Channel sets
 - Identical to AMSR-E (no O₂ band channels)
 - 6.925, 7.3, 10.65, 18.7, 23.8, 36.5, 89.0GHz
 - Dual polarization
- Calibration
 - Improvements of hot load etc.
 - Enhance pre-launch calibration testing
- Orbit
 - A-Train
- Mission life
 - 5 years

Improvement of hot load

- Adoption of temperature controlled reflector over hot load
- Minimize the effect of thermal interference
- Design results shows the maximum temperature difference less than 2K
- Brightness temperature accuracy will be around 0.1K

Prototyping and testing

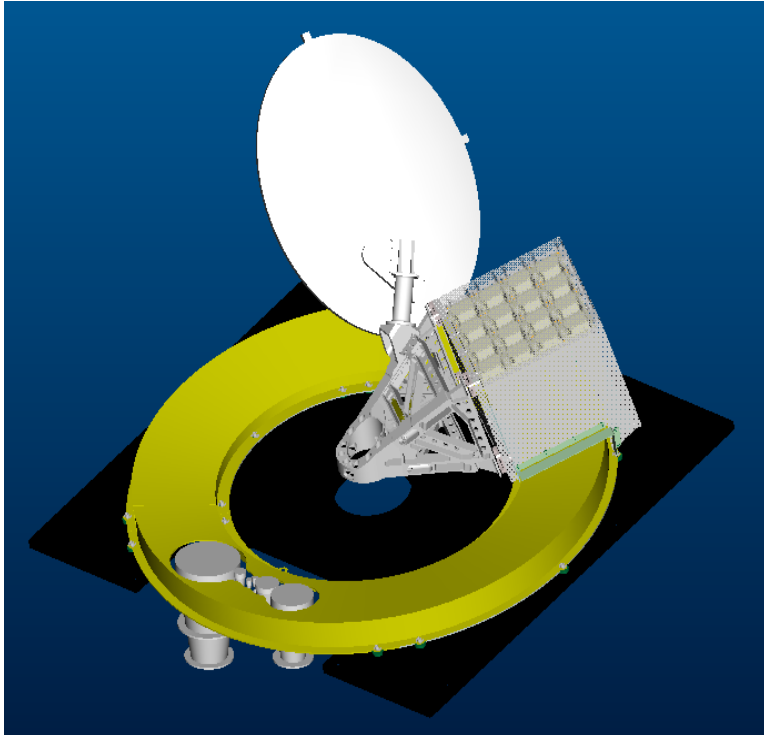

Calibration Assembly

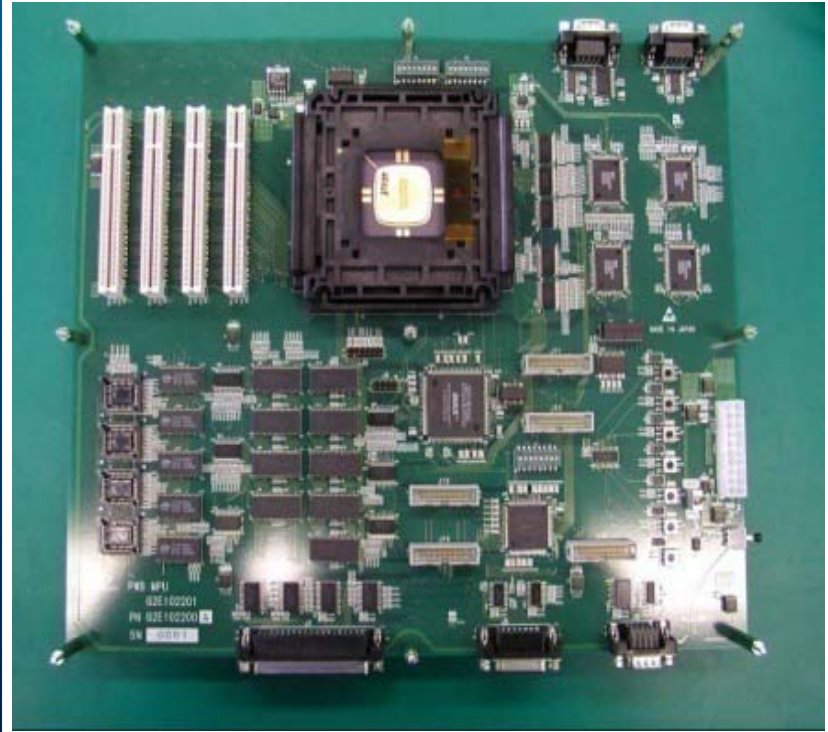

MPU testing board

Improvement of HTS(Hot Load)

- (1) Temperature inside HTS is kept constant (= 20 degrees C) using heaters on 5 walls of HTS and TCP.
- (2) Sunshields attached to HTS and TCP minimize the sun light reflection into HTS.
- (3) TCP thermally isolates HTS from SU structure (much colder than HTS).

HTS: High Temperature noise Source, TCP: Thermal Control Panel, SU: Sensor Unit

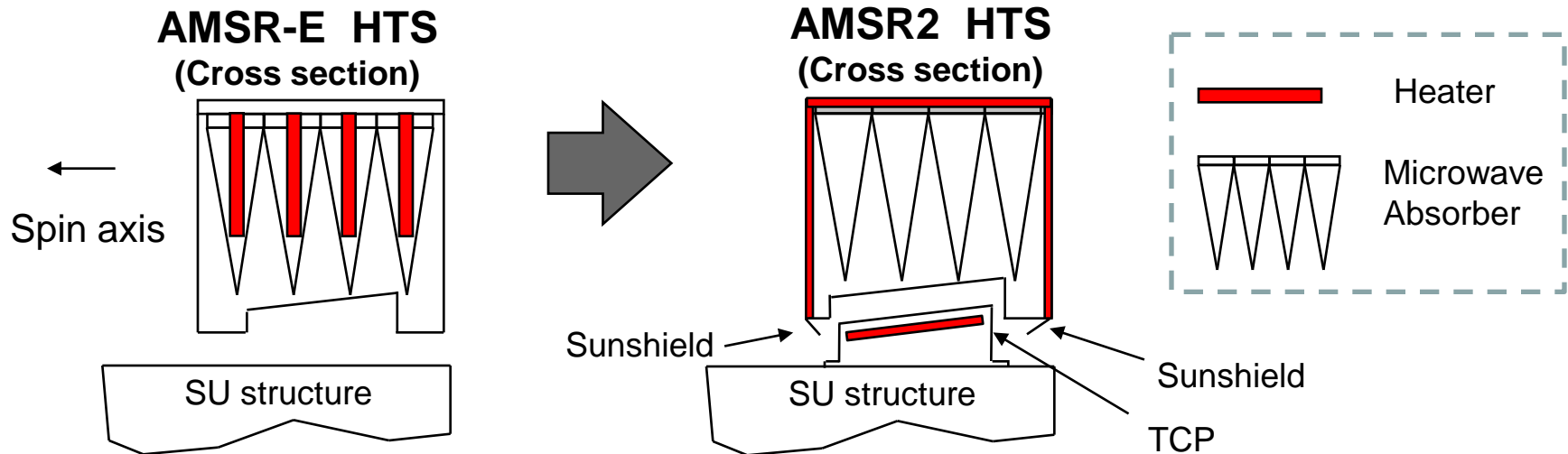

- ◆ Maximum temperature difference inside HTS : less than 2K
- ◆ Estimated brightness temperature accuracy :
 - 0.2 K (Variable bias during orbit, season, design life)
 - 0.1 K (Random due to quantization)

Temperature Resolution

Frequency	Resolution(target)
6.925	<0.34(0.3)
7.3	<0.43
10.65	< 0.7(0.6)
18.7	< 0.7(0.6)
23.8	< 0.6(0.55)
36.5	< 0.7(0.65)
89.0	< 1.2(1.1)

Overview of AMSR2 instrument



Deployed

Stowed

- Deployable main reflector system with 2.0m diameter.
- Frequency channel set is identical to that of AMSR-E except 7.3GHz channel for RFI mitigation.
- Two-point external calibration with the improved HTS (hot-load).
- Deep-space maneuver will be considered to check the consistency between main reflector and CSM.

GCOM-W1/AMSR2 characteristics	
Orbit	Sun Synchronous with 699.6km altitude (over the equator)
Launch	JFY2011
Design-Life	5-years
Local time	13:30 LTAN
Swath width	1450km
Antenna	2.0m offset parabola
Incidence angle	Nominal 55 degree

AMSR2 Channel Set					
Center Freq. [GHz]	Band width [MHz]	Polarization	Beam width [deg] (Ground res. [km])	Sampling interval [km]	
6.925 / 7.3	350	V and H	1.8 (35 x 62)	10	
10.65	100		1.7 (34 x 58)		
18.7	200		1.2 (24 x 42)		
23.8	400		0.65 (14 x 22)		
36.5	1000		0.75 (15 x 26)		
89.0	3000		0.35 (7 x 12)		
				0.15 (3 x 5)	5

Cross Calibration with AMSR-E

- AMSR-E and AMSR2 will remain in A-train at least 1 year.
- Cross calibration will be conducted during this 1 year period.
- New calibration parameters of AMSR-E will be determined.
- The whole AMSR-E products will be reprocessed using this new parameters.

products	IFOV	std. accr.	dynamic range
brightness temp.	5-50km	$\pm 1.5\text{K}$	2.7-340K
total prec. water	15km	$\pm 3.5\text{kg/m}^3$	0-70kg/m³
cloud liq. water	15km	$\pm 0.05\text{kg/m}^2$	0-1.0kg/m²
precipitation	15km	Ocean: 50% Land: $\pm 120\%$	0-20mm/h
SST	50km	$\pm 5\text{ }^\circ\text{C}$	-2-35$^\circ\text{C}$
sea surf. winds	15km	$\pm 1\text{m/s}$	0-30m/s
sea ice conc.	15km	$\pm 10\%$	0-100%
snow depth	30km	$\pm 20\text{cm}$	0-100cm
soil moisture	50km	$\pm 10\%$	0-40%

Oceanic geophysical parameters by AMSR

Global Monthly Mean in April 2003

AMSR 200304 Monthly TPW (kg/m²) Takeuchi Algorithm

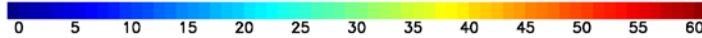
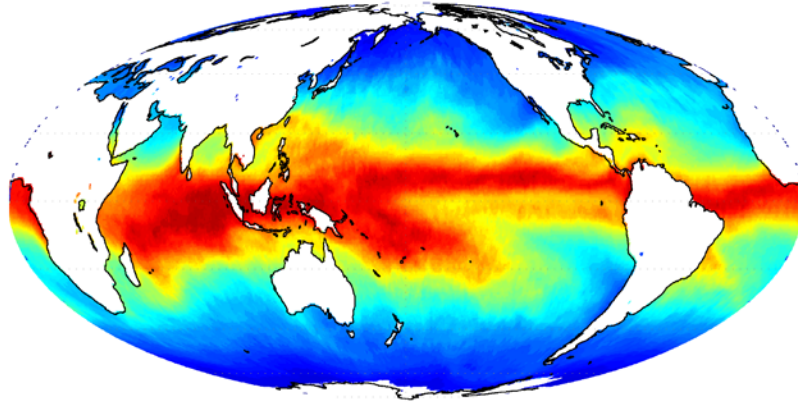

Total precipitable water

AMSR 200304 Monthly CLW (kg/m²) Wentz Algorithm

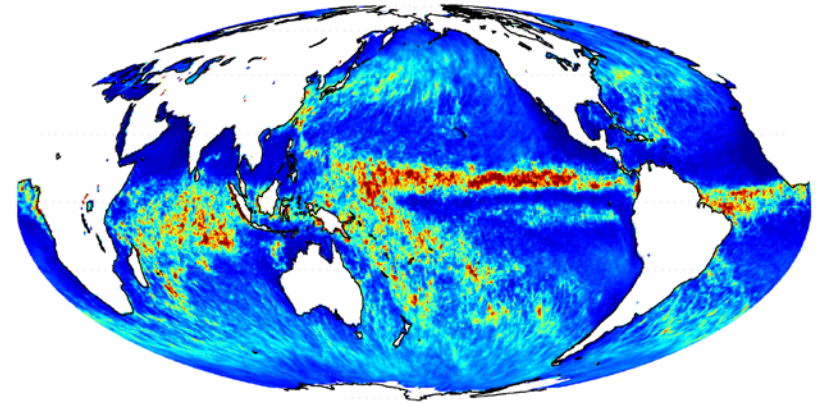

Cloud liquid water

AMSR 200304 Monthly SSW (m/s) Shibata Algorithm

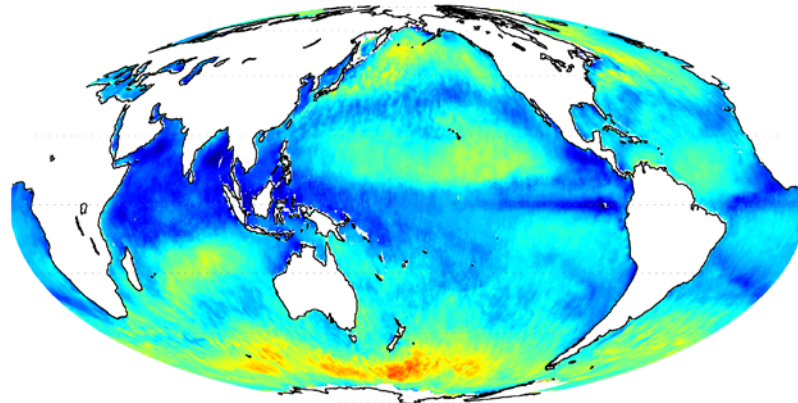

Sea surface wind speed

AMSR 200304 Monthly Precip. (mm) Liu Algorithm

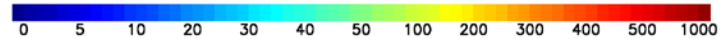
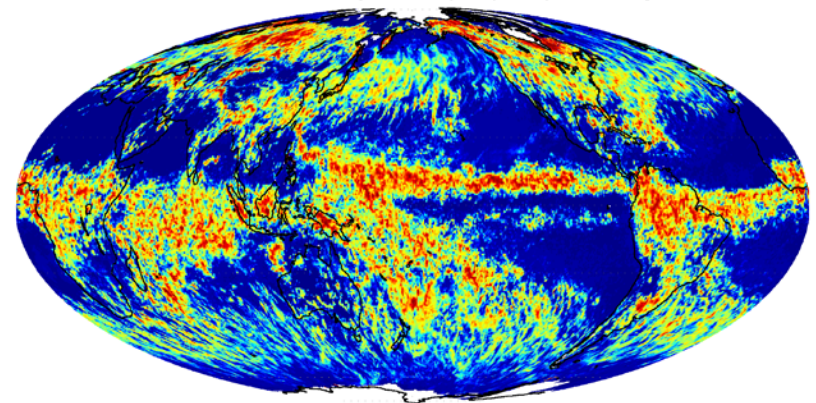

Precipitation

AMSR-E Soil Moisture

- C-band (7GHz) channels are currently best available frequency for retrieving global, long-term soil moisture content from satellite.
- Synergy with L-band radiometers (e.g., SMOS, SMAP) and high-resolution SAR instruments are desired.

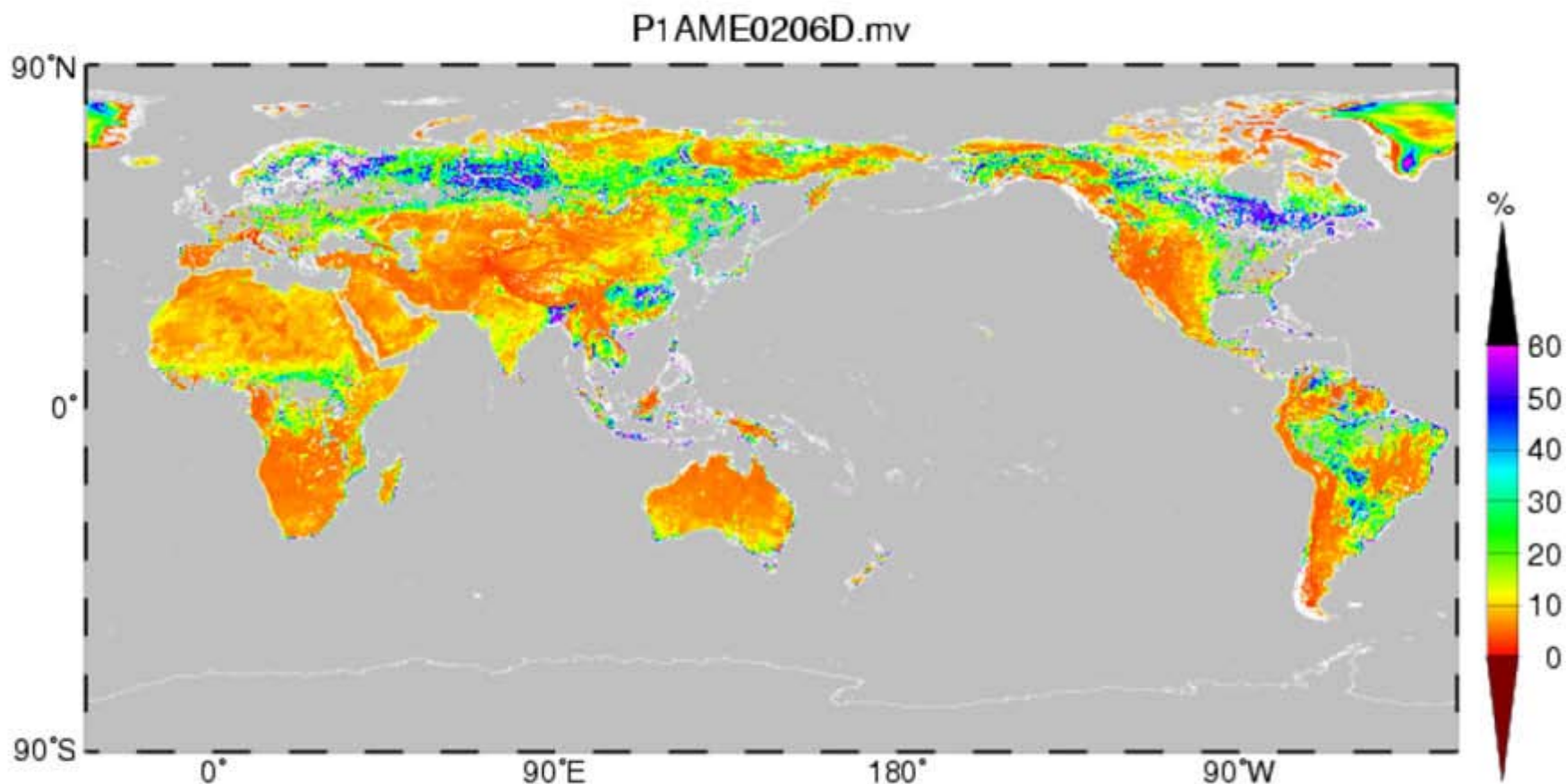

Soil moisture standard product is being generated by using 10GHz as a primary frequency due to the radio frequency interference issue in 6.9GHz band.

Soil Moisture and Precipitation

AMSR-E Soil Moisture

- L2, Descending
- Volumetric SoilMoisture [%]

Precipitation :

- Total amount of precipitation for 48 hours before AMSR-E observation.
- Data source: GSMAp MVK hourly (JST-CREST/GSMAp)

AQUA/AMSR-E SM May. 23, 2003 DES

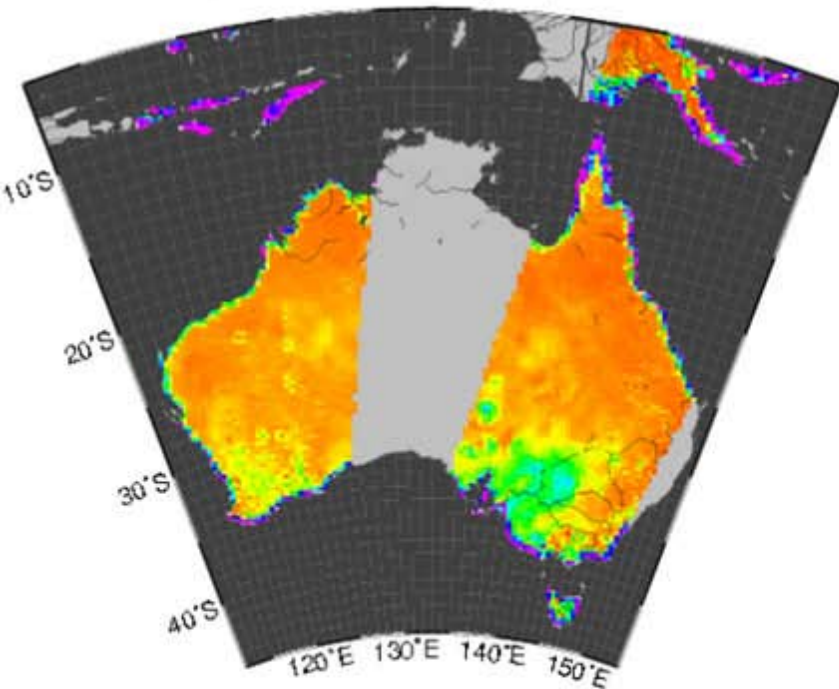

GSMAp MVK 2Days Precipitation May. 23 2003

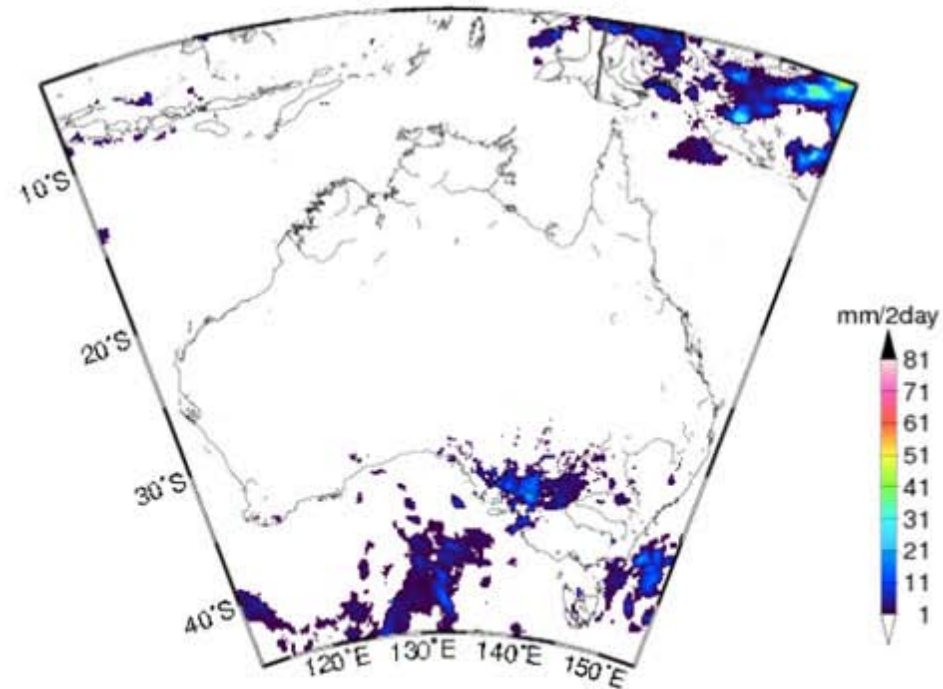

Soil Moisture Observation

- AMSR-E soil moisture anomalies over south-eastern Australia (green rectangle) averaged Sep.-Oct. 2005 and 2006 are compared to wheat production.

2005

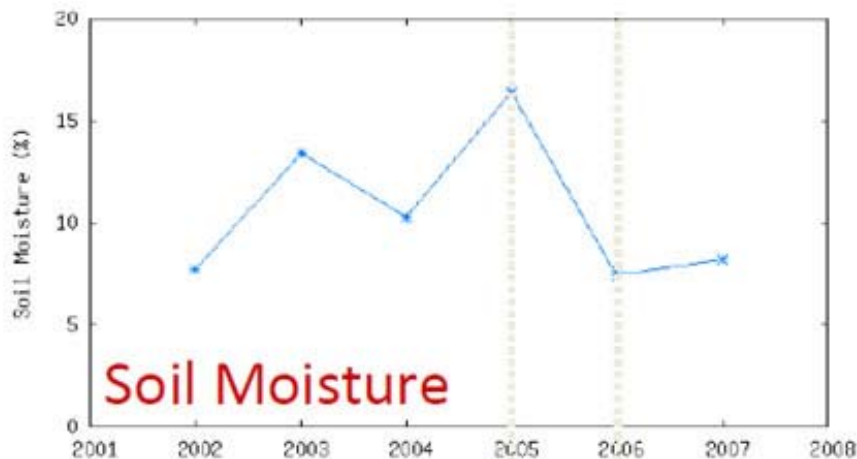
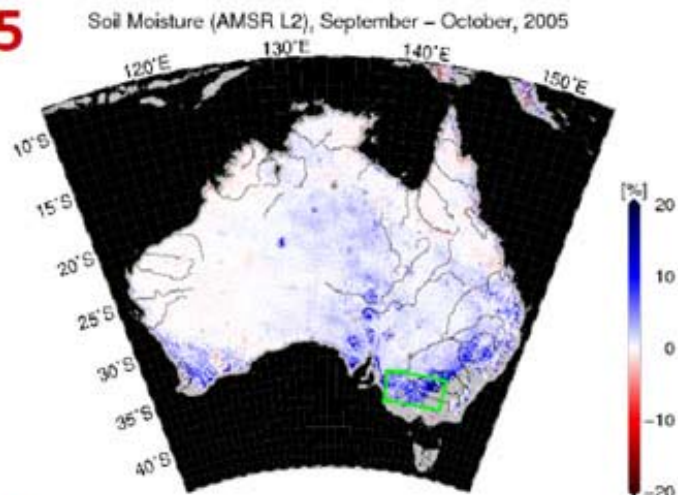

2006

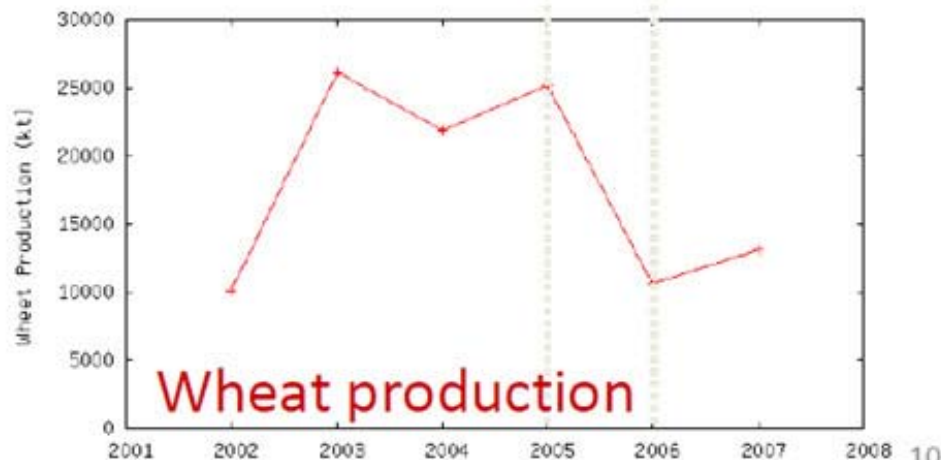
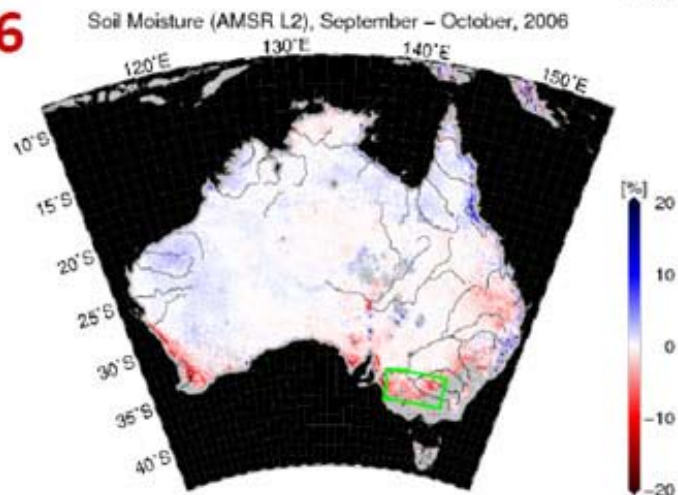

Source: Australian Bureau of Agricultural and Resource Economics

Microwave and IR SST Combination

- C-band (6.9GHz) is indispensable frequency for retrieving SST and soil moisture. Microwave measurement can provide cloud-through frequent SST mapping.
- Microwave and IR observations complement each other in terms of spatial resolution and error sources. Importance and needs of Merged SST from microwave and IR are increasing.

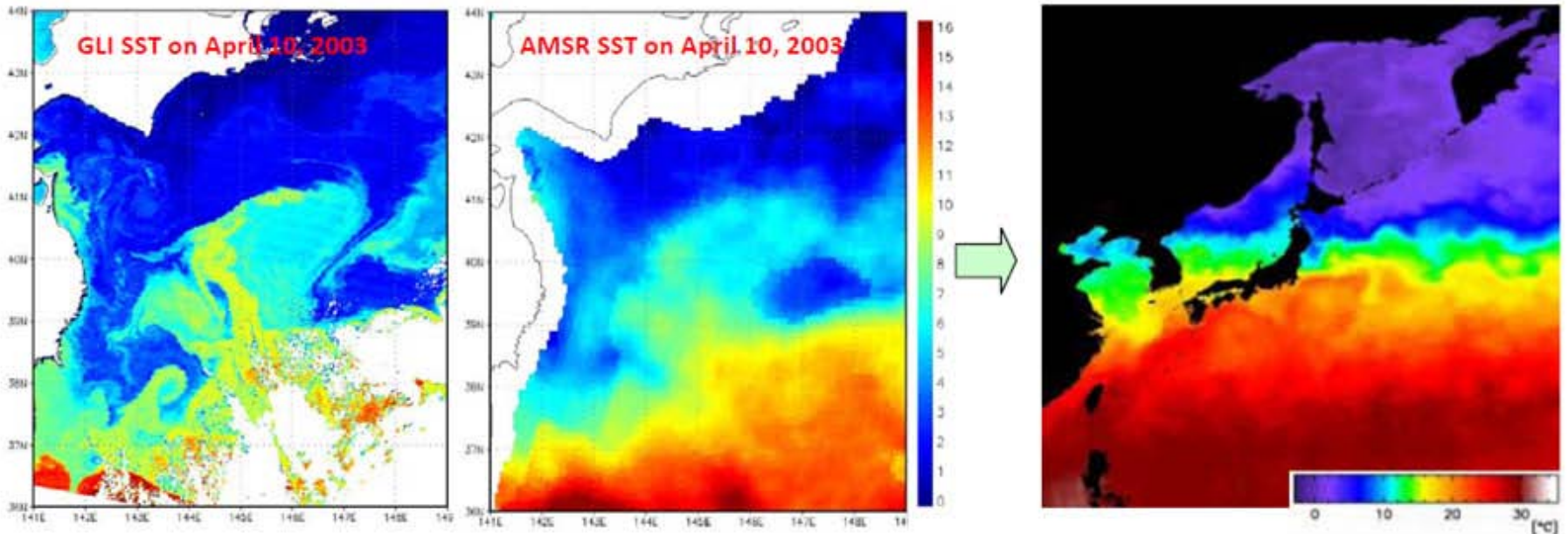

SST images around east coast of Japan on April 10, 2003, observed by GLI (left) and AMSR (right). Difference of spatial resolution and cloud effect are clearly seen in the figures.

Image of the New Generation Sea Surface Temperature (NGSST) for Open Ocean on May 10, 2005. Provided by NGSST development group led by Professor Kawamura of Tohoku University.

SST anomaly in northern high latitudes

SST Anomaly(AMSRE-Climatology)

Jul,2002

Period:Jul 01-29

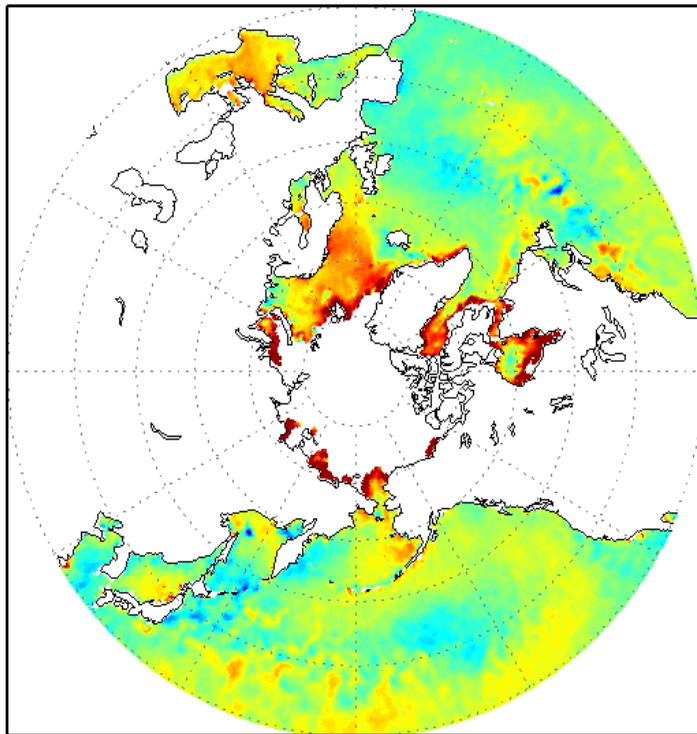

JAXA/EORC

SST Anomaly(AMSRE-Climatology)

Jul,2007

Period:Jul 01-31

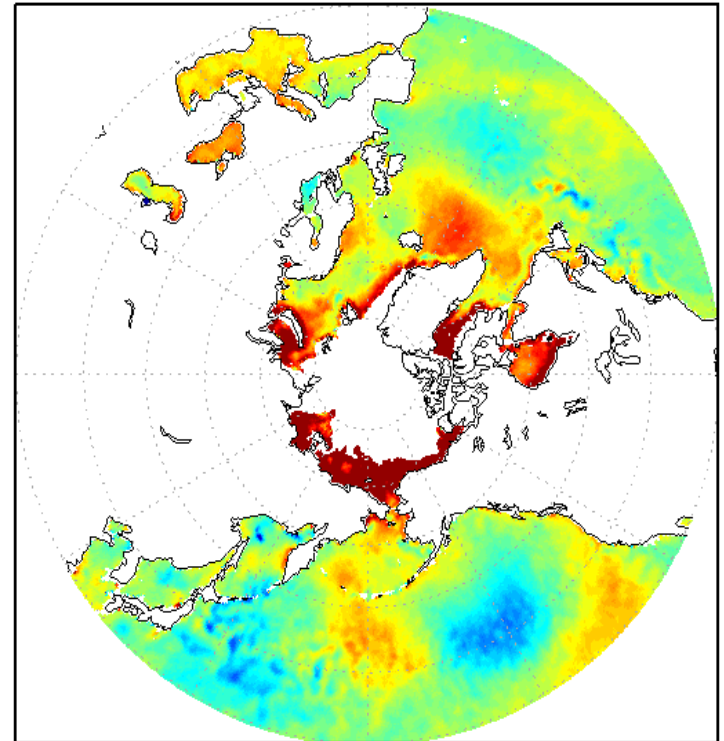

JAXA/EORC

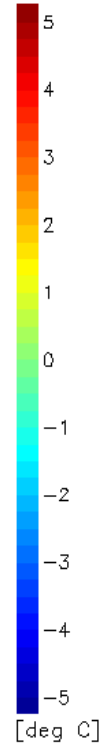

Monthly SST anomaly in northern high latitude oceans for July 2002 (left) and July 2007 (right).

Changes in AMSR-E sea ice

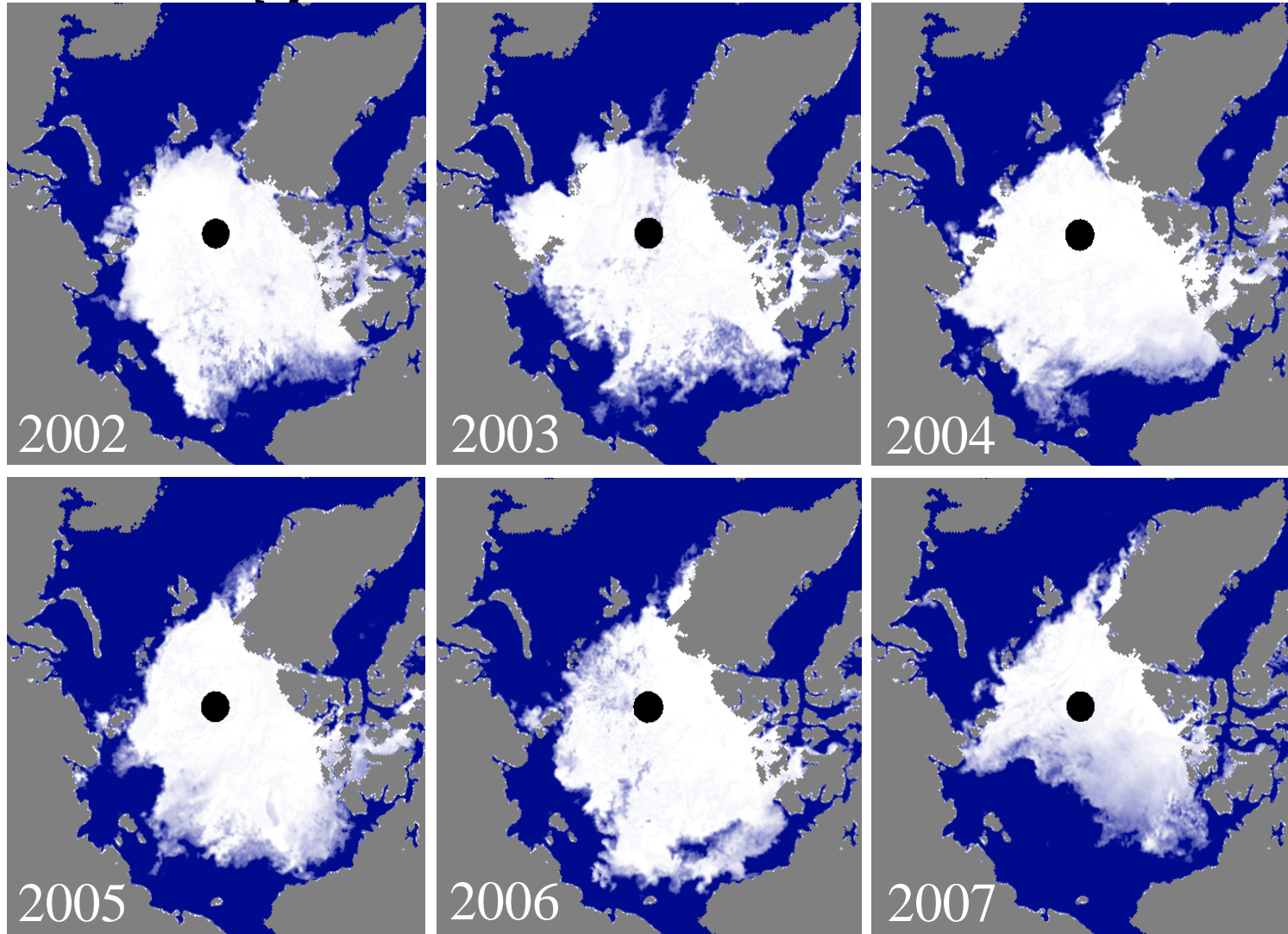

AMSR-E sea ice extent over northern polar region on August 20 of recent 6 years (2002-2007). Images were obtained from the Arctic Sea-Ice Monitor site maintained by the International Arctic Research Center (<http://www.ijis.iarc.uaf.edu/en/index.htm>).

Recent Status of Ice Extent

Sea Ice Extent : 8,314,219 km² (July 9, 2010)

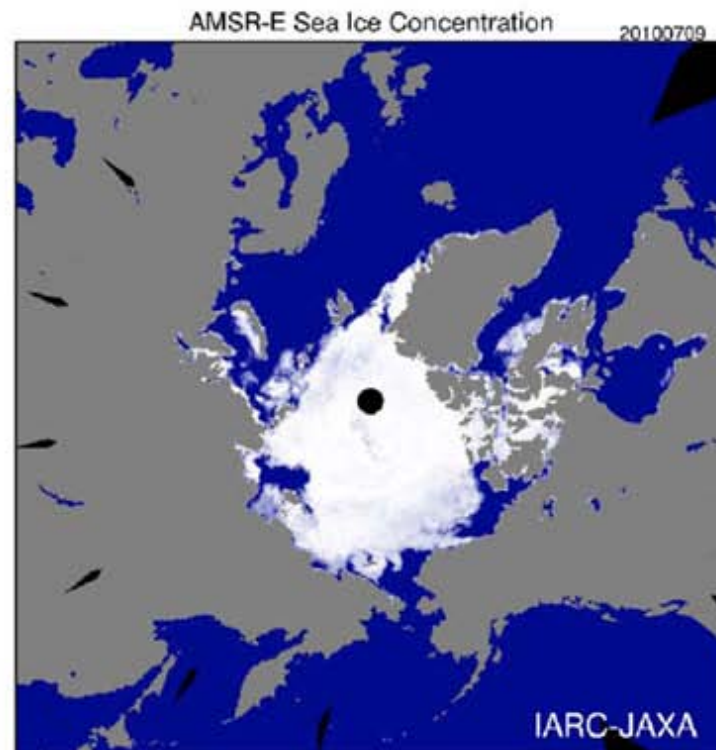
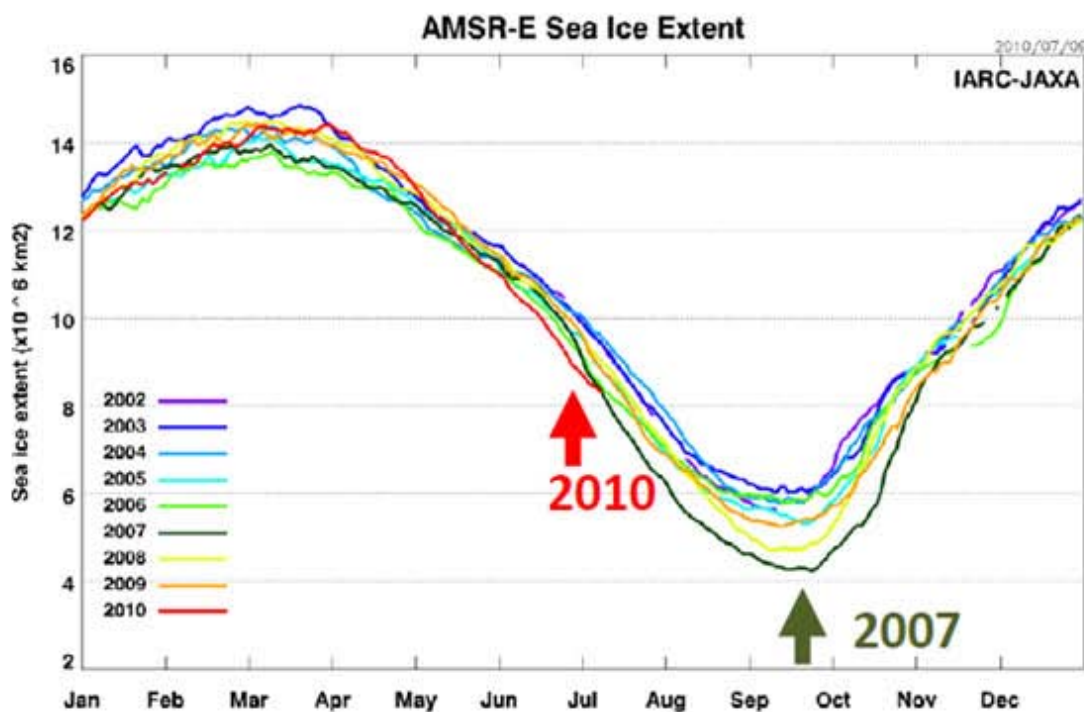

Time series of AMSR-E sea ice extent over Arctic Oceans. Daily updates are available at the Arctic Sea-Ice Monitor site maintained by the International Arctic Research Center (<http://www.ijis.iarc.uaf.edu/en/index.htm>).

Global Rainfall Map in Near Real Time

- Displaying global rainfall map merging TRMM, AMSR-E and other satellite information
- Available 4-hr after observation
- Browse images, 24-hr animation, displaying by Google Earth
- 0.1-degree lat/lon grid, hourly products
- Data are also available via password protected ftp site
- Based on JST/CREST GSMaP algorithm



<http://sharaku.eorc.jaxa.jp/GSMaP/>

GSMaP_NRT Observed Cyclone Attack in Myanmar (May 2008)

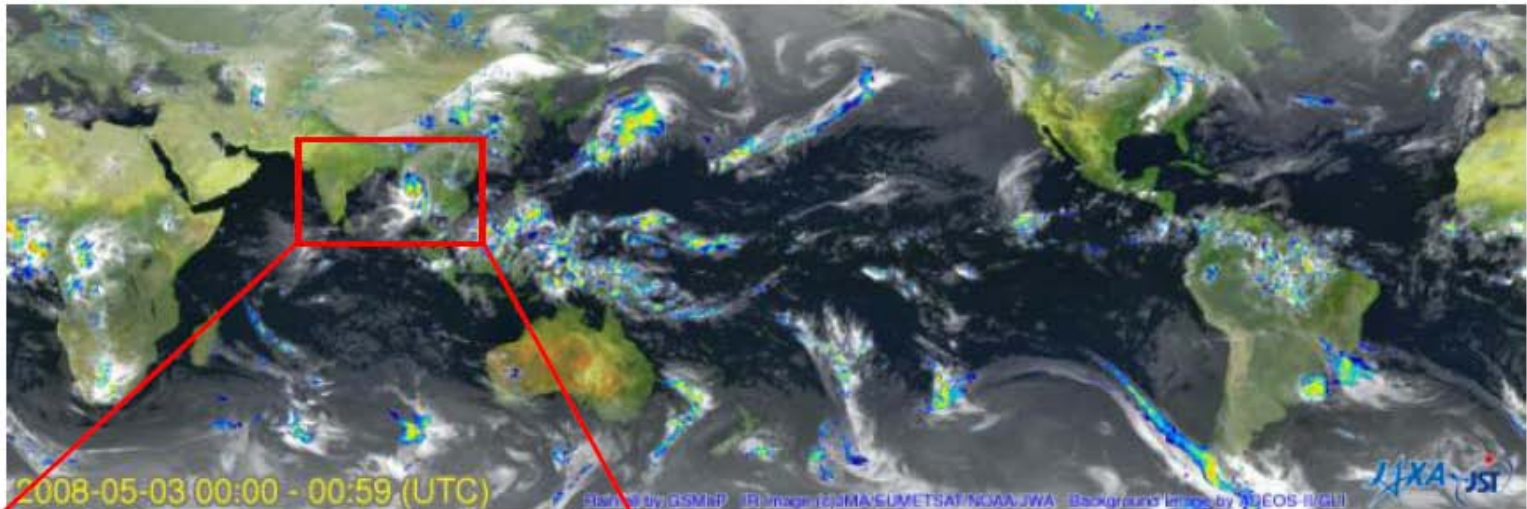

00Z
May 3,
2008

April 28 ~ May 3

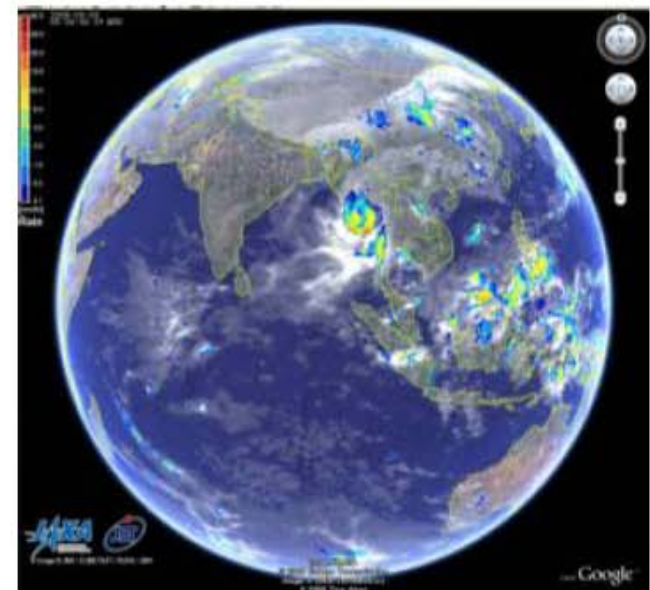
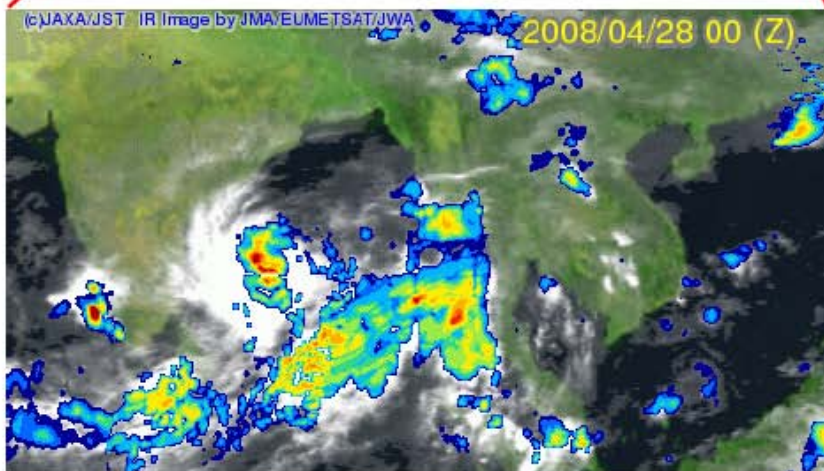

GCOM-C Science Targets

Radiation budget of the atmosphere-surface system

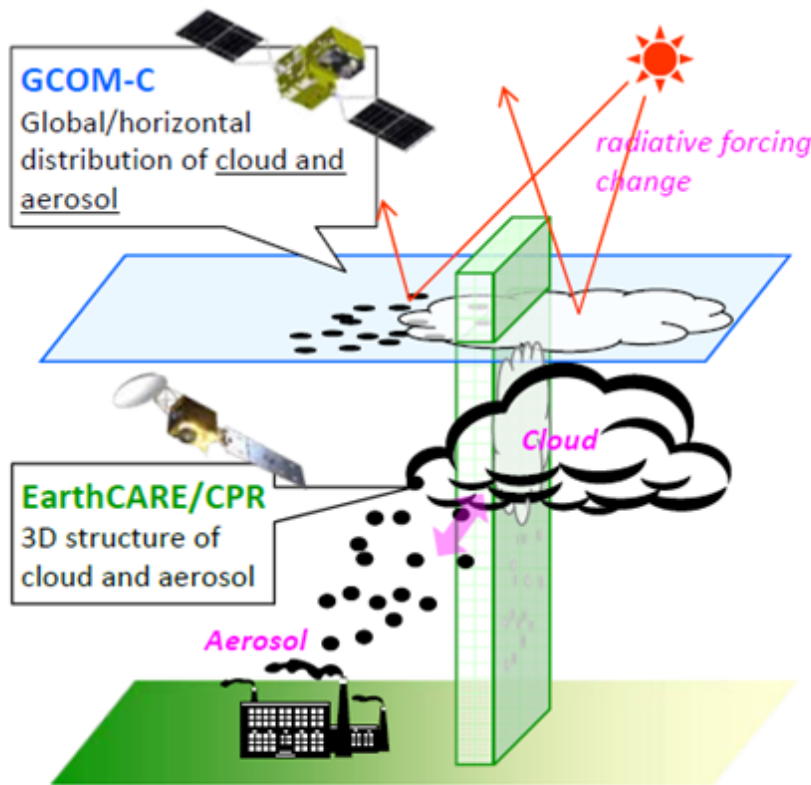

Today's the most significant factor: atmospheric CO₂

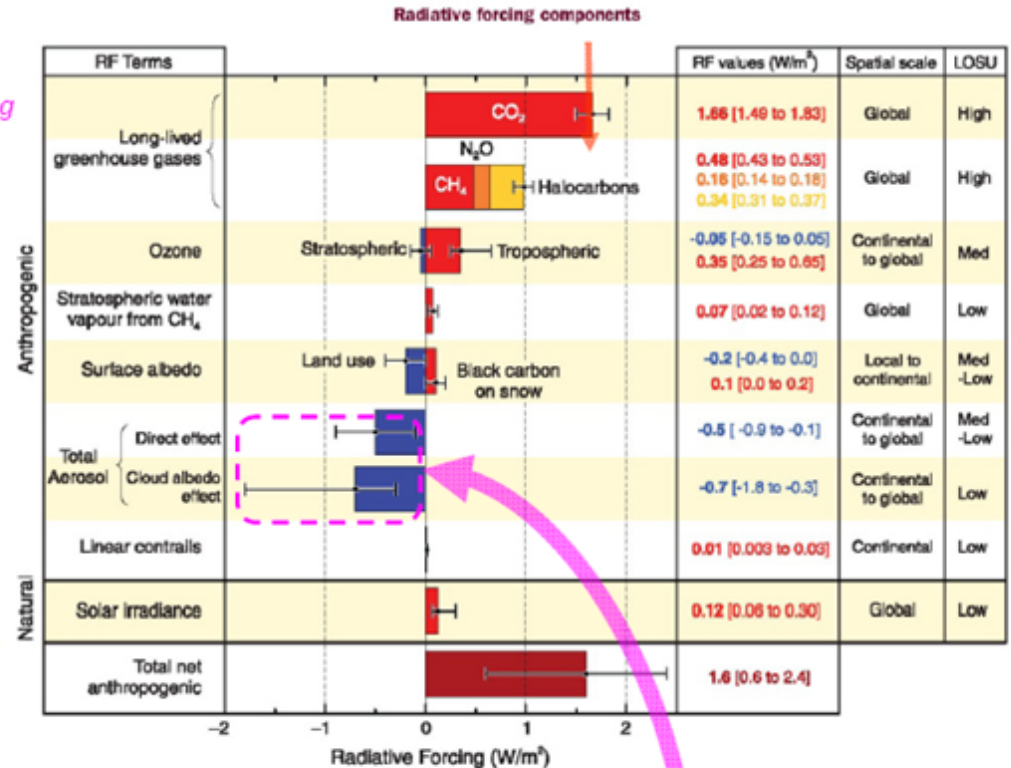

Monitoring and process investigation about cloud and aerosol by GCOM-C & EarthCARE

Figure 2.4. Global average radiative forcing (RF) in 2005 (best estimates and 5 to 95% uncertainty ranges) with respect to 1750 for CO₂, CH₄, N₂O and other important agents and mechanisms, together with the typical geographical extent (spatial scale) of the forcing and the assessed level of scientific understanding (LOSU). Aerosols from explosive volcanic eruptions contribute an additional episodic cooling term for a few years following an eruption. The range for linear contrails does not include other possible effects of aviation on cloudiness. (WG1 Figure SPM.2)

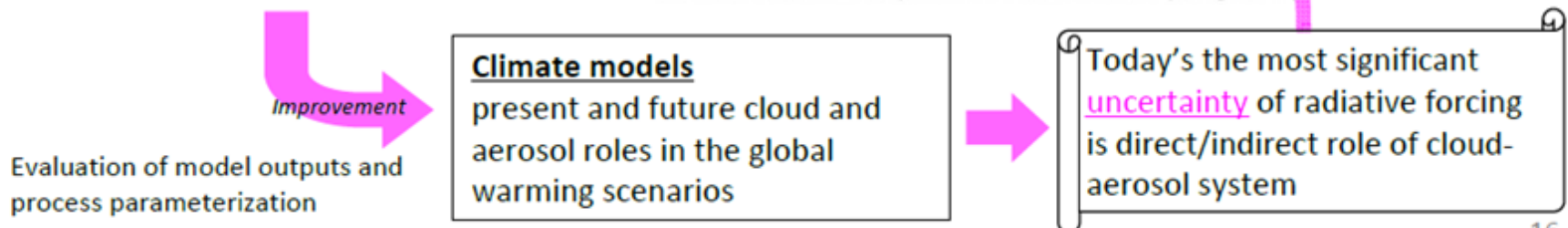

CGOM-C1

- Orbit
 - Sun synchronous orbit
 - Height: about 800km
 - Local time of descending node: 10:30
- Weight: about 2.1t
- Power : about 4kW
- Lifetime: 5 years
- Data transmission
 - Global observation data are stored and transmitted every orbit period
 - Observed data over Japanese islands are transmitted to JAXA ground station in real time

SGLI

- Wide spectrum coverage
- Near UV, VIS, NIR, SWIR, TIR
- Polarization measurements
- Multiple angle observation
- Multiple telescopes

VNR

- Composed of 3 telescopes to cover the total swath
- Each telescope covers 24 degree achieving 70 degree in total

Polarization

- Composed of 1 telescope for each channel
- IFOV is 55 degree
- Looking fore, nadir & aft
- One camera with tilt or two cameras?

Ch.	central wavelength [nm]	IFOV [m]	$\Delta\lambda$ [nm]	$L\lambda$ [W/m ² /str/ μ m]	L_{\max} [W/m ² /str/ μ m]	S/N
VN1	380	250	10	60	210	250
VN2	412	250	10	75	250	400
VN3	443	250	10	64	400	300
VN4	490	250	10	53	120	400
VN5	530	250	20	41	350	250
VN6	565	250	20	33	90	400
VN7	673.5	250	20	23	62	400
VN8	673.5	250	20	25	210	250
VN9	763	1000	12	40	350	400
VN10	868.5	250	20	8	30	400
VN11	868.5	250	20	30	300	200

Polarization channels (3 directions)

Ch.	central wavelength [nm]	IFOV [m]	$\Delta\lambda$ [nm]	$L\lambda$ [W/m ² /str/ μ m]	L_{\max} [W/m ² /str/ μ m]	S/N
673-P1	673.5	1000	20	25	250	250
673-P2	673.5	1000	20	25	250	250
673-P3	673.5	1000	20	25	250	250
868-P1	868.5	1000	20	30	300	250
868-P2	868.5	1000	20	30	300	250
868-P3	868.5	1000	20	30	300	250

IRS						
Ch.	central wavelength [μm]	IFOV[m]	$\Delta\lambda[\mu\text{m}]$	$L_\lambda[\text{W}/\text{m}^2/\text{s}^2/\text{str}/\mu\text{m}]$ or $T_{\text{std}}[\text{K}]$	$L_{\text{max}}[\text{W}/\text{m}^2/\text{str}/\mu\text{m}]$ or $T_{\text{max}}[\text{K}]$	S/Nor NEdT@300[K]
SW1	1.05	1000	0.02	57	248	500
SW2	1.38	1000	0.02	8	103	150
SW3	1.63	250	0.2	3	50	57
SW4	2.21	1000	0.05	1.9	20	211
T1	10.8	500	0.7	300	340	0.2
T2	12.0	500	0.7	300	340	0.2

2. GCOM-C products and SGLI design

- 2.8 SGLI design (VNR and IRS)

- SGLI system consists of two components: **SGLI-VNR** and **SGLI-IRS** to optimize optics for each wavelength range
- SGLI-VNR consists of **11-channel non-polarimetric telescope** and **2-channel along-track slant polarimetric telescope** systems.

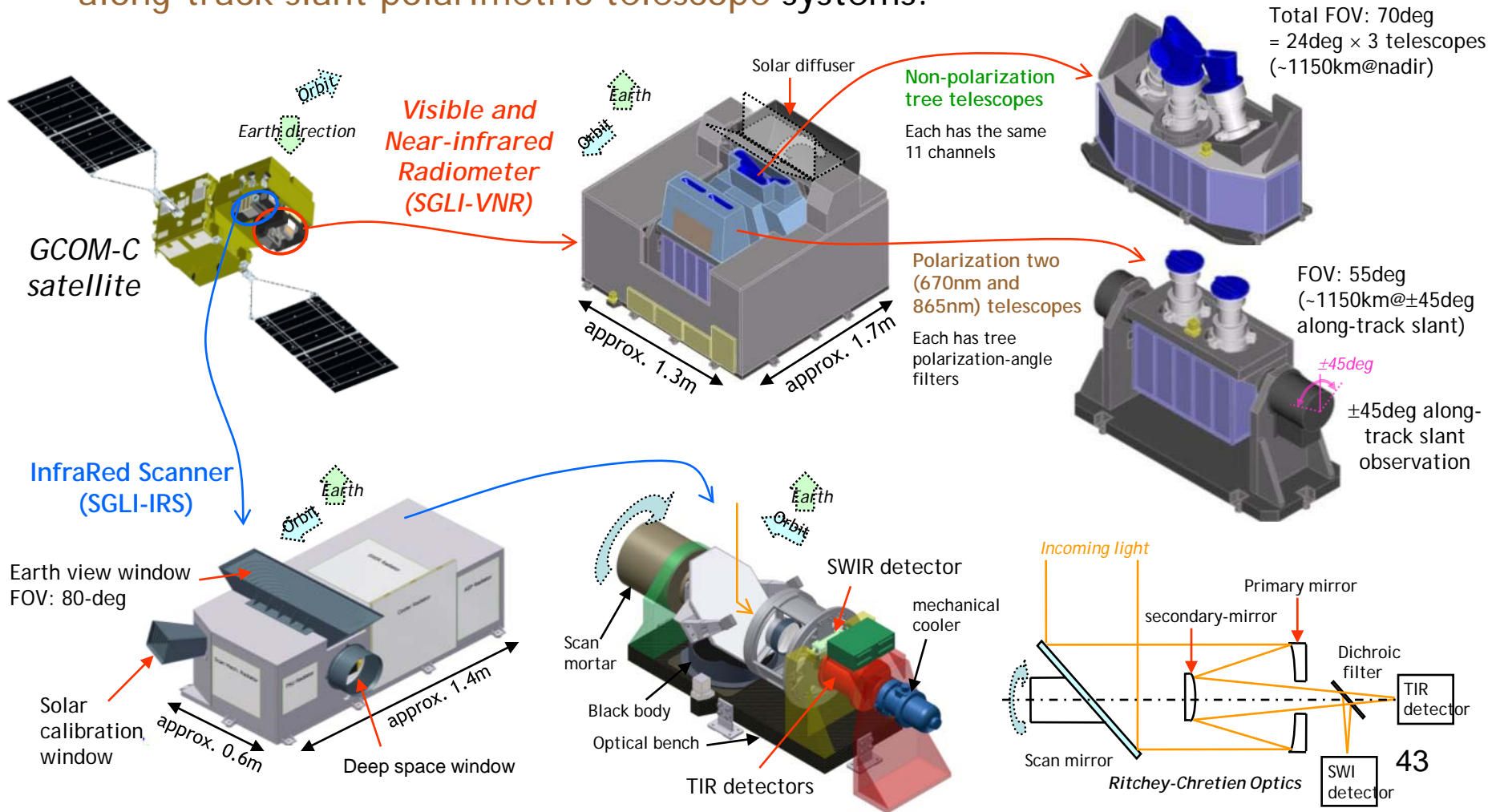

2. GCOM-C products and SGLI design

- 2.1 mission target and product groups

GCOM-C observation targets

Radiation budget

Carbon cycle

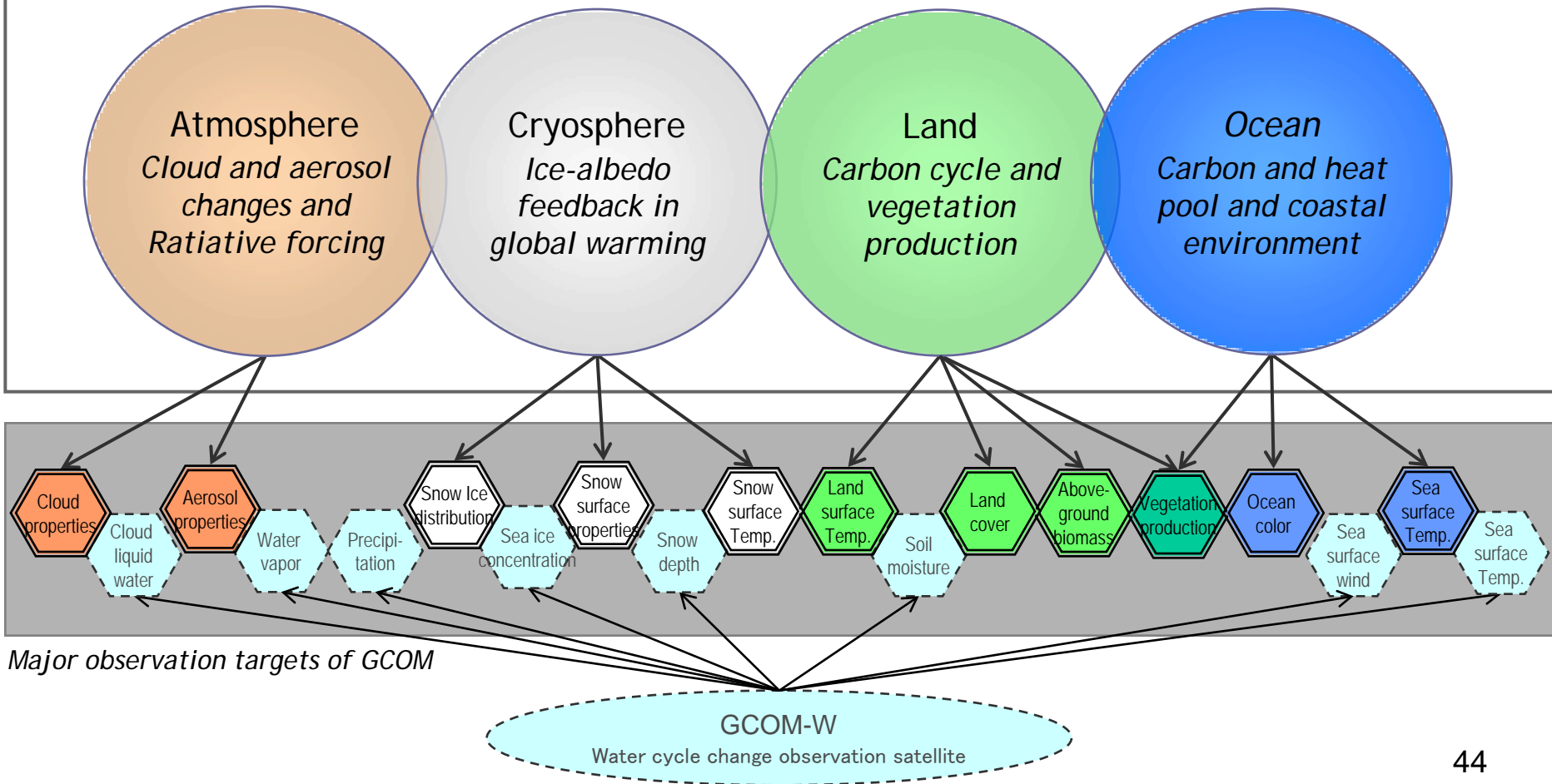

Standard products (land)

products	GSD	accuracy
radiance	250/1000m	5%, 0.5K
geom. corr. rad.	250m	0.5pixel
land surface refl.	250m	5%/10%* ¹
veg. index	250m	20%/15%* ²
veg. roughness. index	1km	20%/15%* ²
shadow index	1km	20%/15%* ²
land surf. temp	500m	2.5K
fAPAR	250m	30%/20%* ²
LAI	250m	30%
above ground biomass	1km	30%

*1 : >443nm / ≤443nm

*2 : grass land / forest

Research products (land)

products	GSD	accuracy
net primary prod.	1km	TBD
veg. water stress index	500m	TBD
fire	500m	TBD
land cover class.	250m	TBD
land surface albedo	1km	TBD

Standard products (atmosphere)

products	GSD	accuracy
cloud flag/type	1km	
cloud type & amount	1km/0.1°	15%
cloud top temp/altitude	1km/0.1°	3k/2km
opt. thick. of water cloud	1km/0.1°	100%
opt. thick. of cirrus	1km/0.1°	70%
aerosol over ocean	1km/0.1°	0.1
aerosol over land UV	1km/0.1°	0.15
aerosol over land pol.	1km/0.1°	0.15

Research products (atmosphere)

products	GSD	accuracy
geom. thickness of water clouds	1km/0.1°	N/A
land surface long wave radiant flux	1km/0.1°	N/A
land surface short wave radiant flux	1km/0.1°	N/A

Standard products (ocean)

products	GSD	accuracy
normalized water leav. rad.	250m/1km/4-9km *1	50%
atm. corr. parameter	250m/1km/4-9km	50%
PAR	250m/1km/4-9km	15%
chlorophyll-a	250m/1km/4-9km	-60-+150%
SS	250m/1km/4-9km	-60-+150%
CDOM	250m/1km/4-9km	-60-+150%
SST	500m/1km/4-9km	0.8K

***1 : 250m:coastal, 1km : open ocean, 4-9km : global**

Research products (ocean)

products	GSD	accuracy
euphotic zone depth	250m/1km/4-9km	N/A
intrinsic opt. char. of seawater	250m/1km/4-9km	N/A
primary production	500m/1km/4-9km	N/A
phytoplankton type	250m/1km/4-9km	N/A
red tide	250m/1km/4-9km	N/A
sensor fusion ocean color	250m/1km	N/A
sensor fusion SST	500m/1km	N/A

Standard products (cryosphere)

products	GSD	accuracy
snow & ice cover	250m/1km	7%
sea ice dist. in Okhotsk sea	250m	5%
snow/ice surface temp.	500m/1km	2K
snow particle size	250m/1km	50%

Research products (cryosphere)

products	GSD	accuracy
snow/sea ice class.	1km	N/A
snow cover over mountains	250m	N/A
snow particle size of semi surface	1km	N/A
surface snow particle size	250m/1km	N/A
snow/ice surface albedo	1km	N/A
snow impurity	250m/1km	N/A
ice sheet roughness	1km	N/A
ice sheet edge monitor	250m	N/A

250m ocean

50m RGB:22/21/20, 2003.5.26

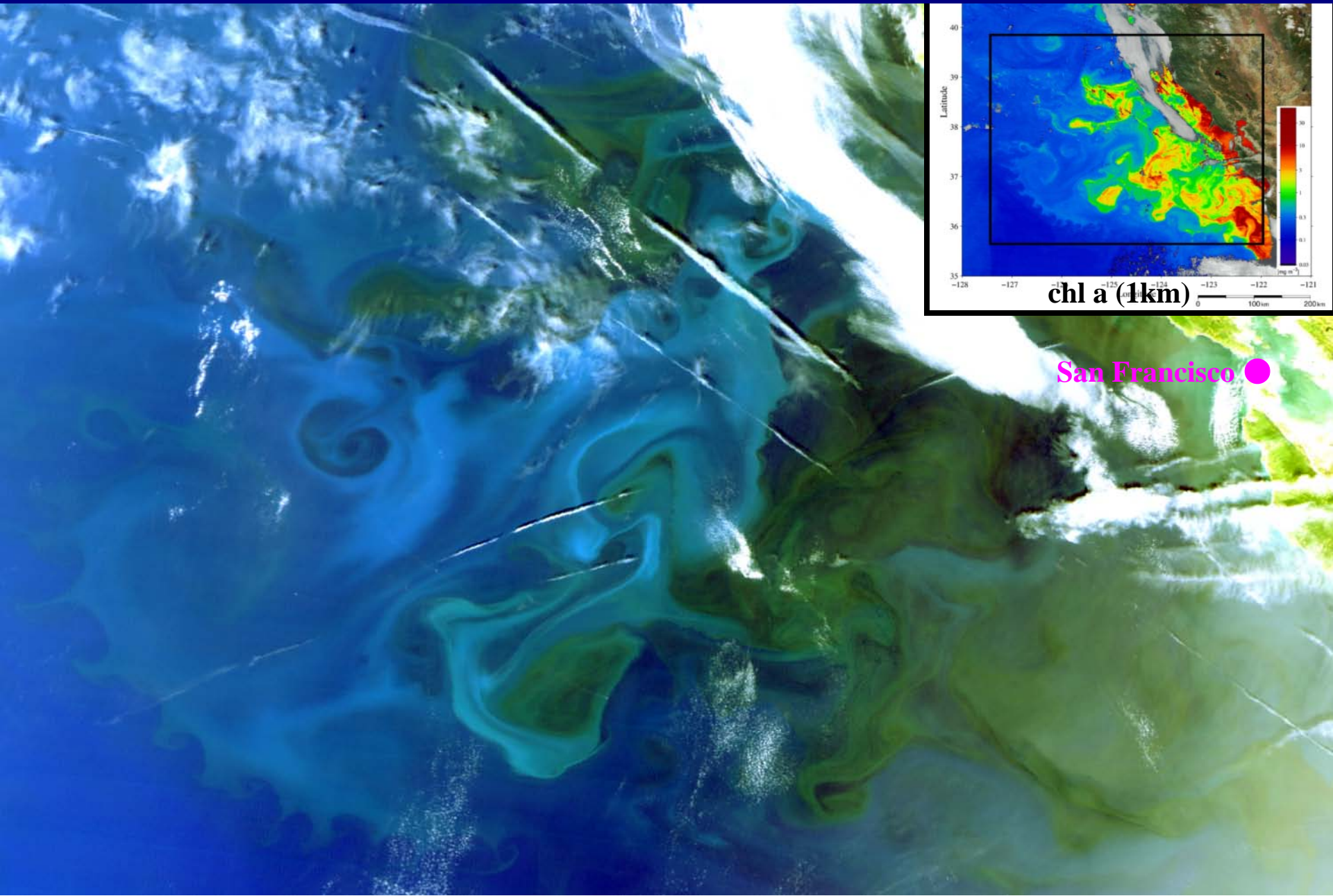

3. Examples of expected GCOM-C product

- 3.4 VNR 250m land and coastal observation

250m Ocean color chlorophyll-a and NDVI simulated using GLI 250m channels

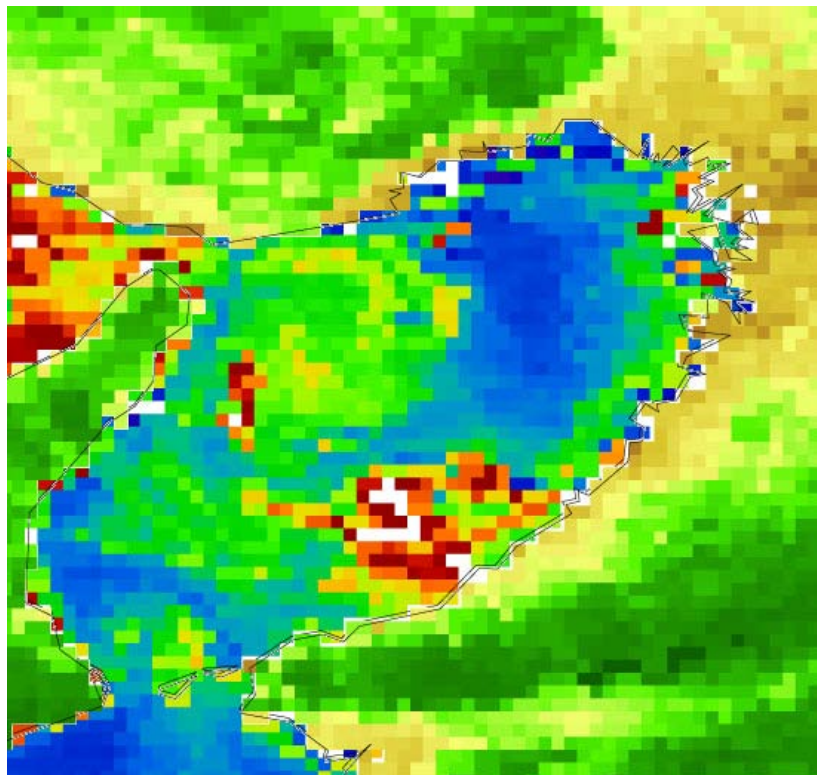

(a) GLI 1km Osaka Bay
(1 Oct. 2003, CHL by LCI)

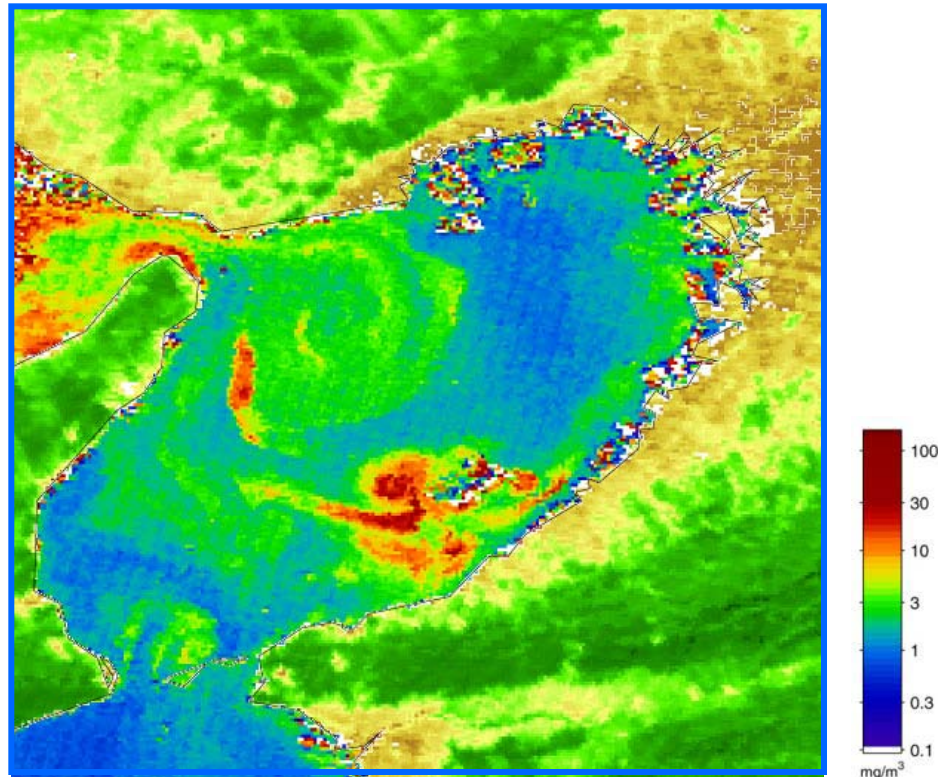

(b) GLI 250m Osaka Bay
(1 Oct. 2003, CHL by LCI)

SGLI 250m resolution will enable to detect more fine structure in the coastal area such as river outflow, regional blooms, and small current.

3. Examples of expected GCOM-C product

- 3.3 VNR 250m land cover classification

- SGLI's 250m channels (11CHs from 380nm to 1640nm) and once/2-day observation and can improve the land cover classification.

凡例	Legend
0. 不明 Unknown	13. 果樹 FrTree : Fruit Trees
1. 密生常緑広葉樹 CEBFor : Closed Evergreen Broadleaf Forest	14. モザイク(耕作地,未開墾地,庭園などの混成地) Mosaic : Including mixture of: cultivated land, natural land, garden, etc.
2. 中層常緑広葉樹 MEBFor : Medium Evergreen Broadleaf Forest	15. 水田と他の耕作地の複合 Crpid1 : Combination of rice land and other crop lands
3. 疎生常緑広葉樹 OEBFor : Open Evergreen Broadleaf Forest	16. 米作地 Crpid2 : Rice in all of year
4. 半落葉広葉樹 SOBFor : Semi Deciduous Broadleaf Forest	17. 洪水被害に遭う水田 Crpid3 : Rice land has one flood season
5. 落葉広葉樹 DBFore : Deciduous Broadleaf Forest	18. 耕作地 Crpid4 : Dry crop land
6. 常緑針葉樹 ENFore : Evergreen Needleleaf Forest	19. 市街地 Urban : Building Area
7. マングローブ林 Mangro : Mangrove Forest	20. 荒地 Barren : Dry Barren
8. 森林サバンナ Wd_Sav : Woody Savannas	21. 牧草と低木 BazanS : Grass and Shrub in Bazan Soil
9. 密生サバンナ CShrub : Closed Shrub	22. 砂,岩石 Sand : Sand, Rock
10. 疎生サバンナ OShrub : Open Shrub	23. 沼地と池(水産養殖地) WetLd1 : Swamp, Pond (Aquaculture land)
11. 牧草と低木 Grass1 : Grass and Shrub	24. 沖積土,湿った砂 WetLd2 : Warp, Wet Sand
12. 牧草と裸地 Grass2 : Grass and Bare Soil	25. 水 Water : Water

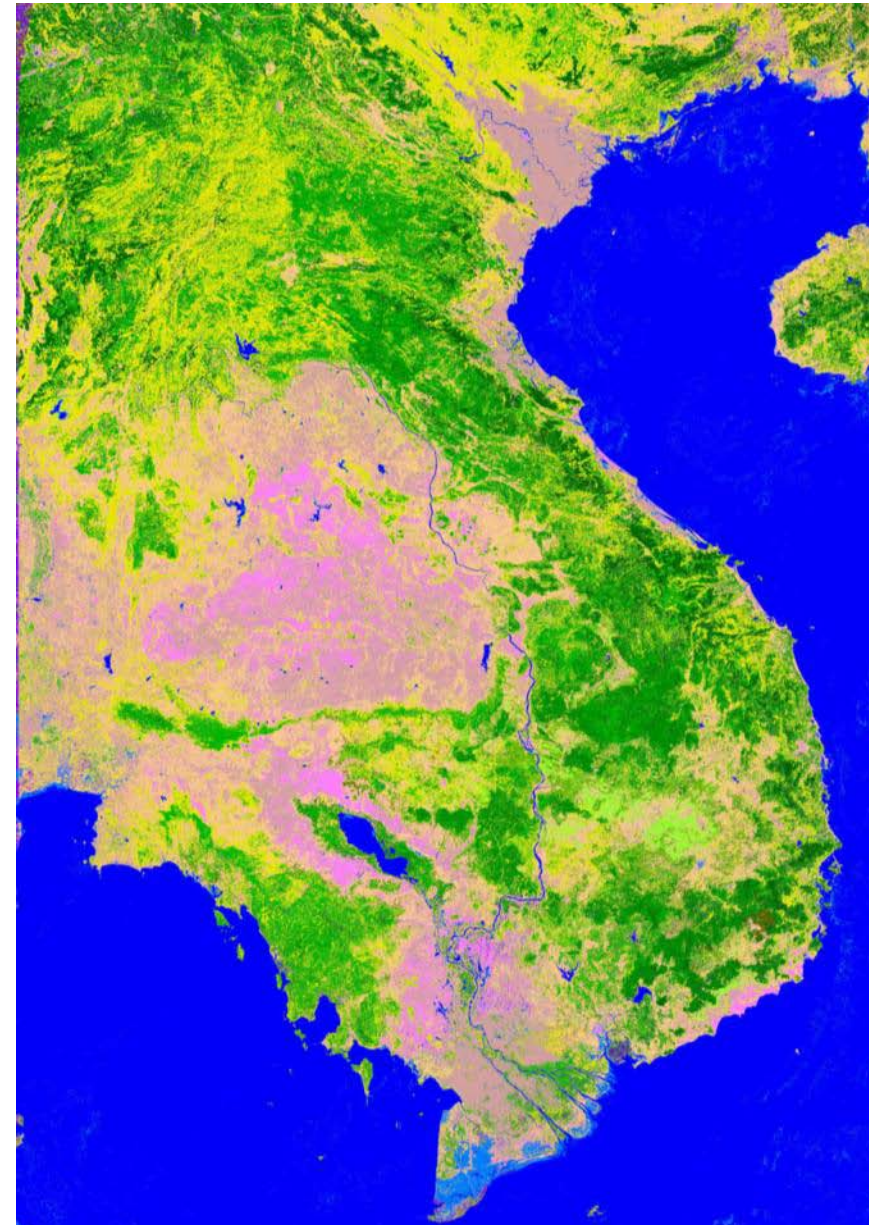

Classification to 25 class (IGBP: International Geosphere-Biosphere Program) using GLI 39 scenes (2003/04~2003/10)

(provided by Dr. Nguyen Dinh Duong, VAST(Vietnamese Academy of Science and Technology))

3. Examples of expected GCOM-C product

- 3.5 Thermal infrared 500m land and coastal observation

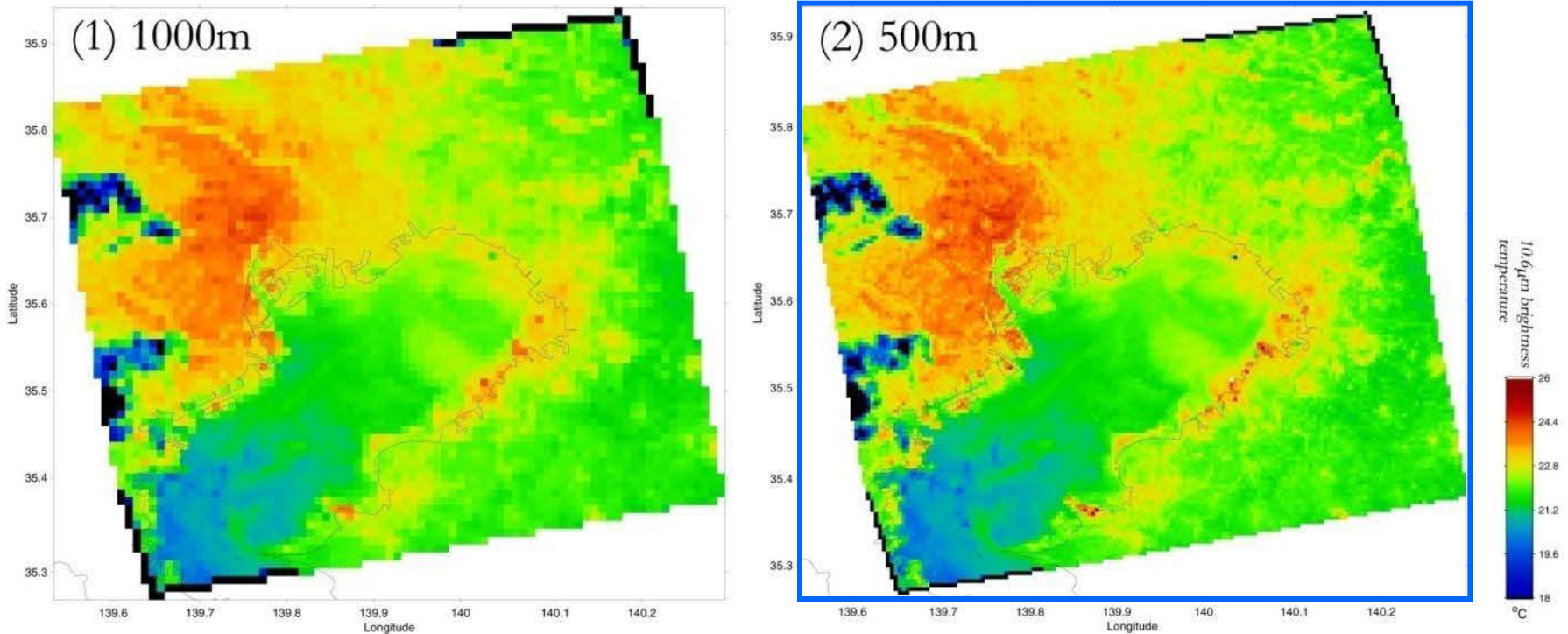

- The 500m and 1000m spatial resolution thermal infrared images are simulated using ASTER data (original resolution is 90m) (Tokyo Bay in the night on August 4, 2003).
- *SGLI 500m-resolution thermal infrared channels will enable detection of fine structures such as land and coastal surface temperature influenced by the city and the river flows.*

Examples of expected GCOM-C product

- 6. Land aerosol by Near-UV and polarization

• Near-UV aerosol

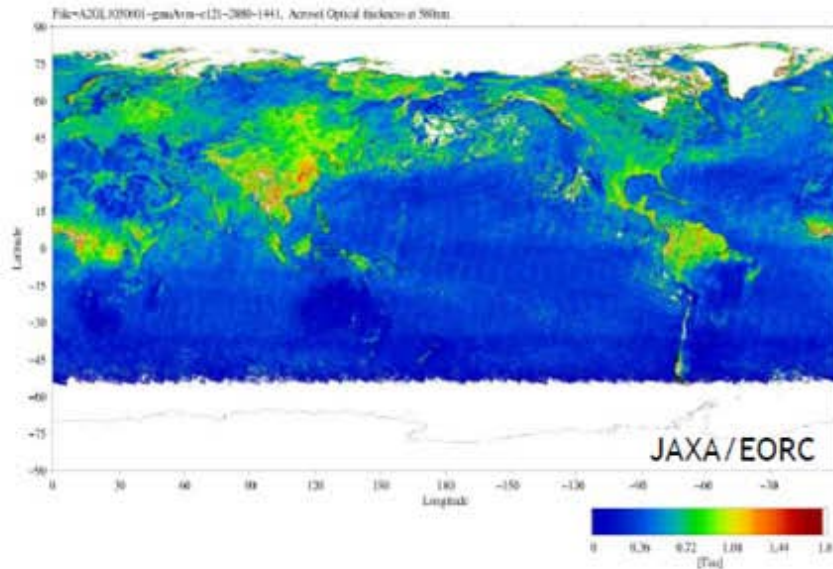

Global aerosol optical thickness in June 2003 using the GLI Near-UV (380nm) channel (NIR is used for the ocean area)

• Polarization aerosol

AOT June 2003 using POLDER-2

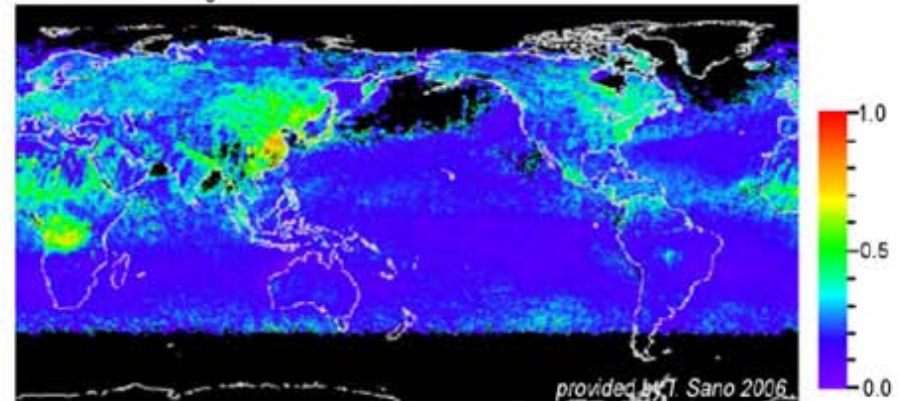

Global aerosol optical thickness in June 2003 using POLDER-2 polarization reflectance

- Not only over the ocean, SGLI will estimate **land-area aerosols using near-UV (380nm) and polarization channels** which are more sensitive to atmosphere scattering rather than land surface reflection.
- Combination of aerosol absorption by Near-UV and fine-mode aerosol properties by polarization.

Examples of expected GCOM-C product

- 9. Marine resource monitoring and management

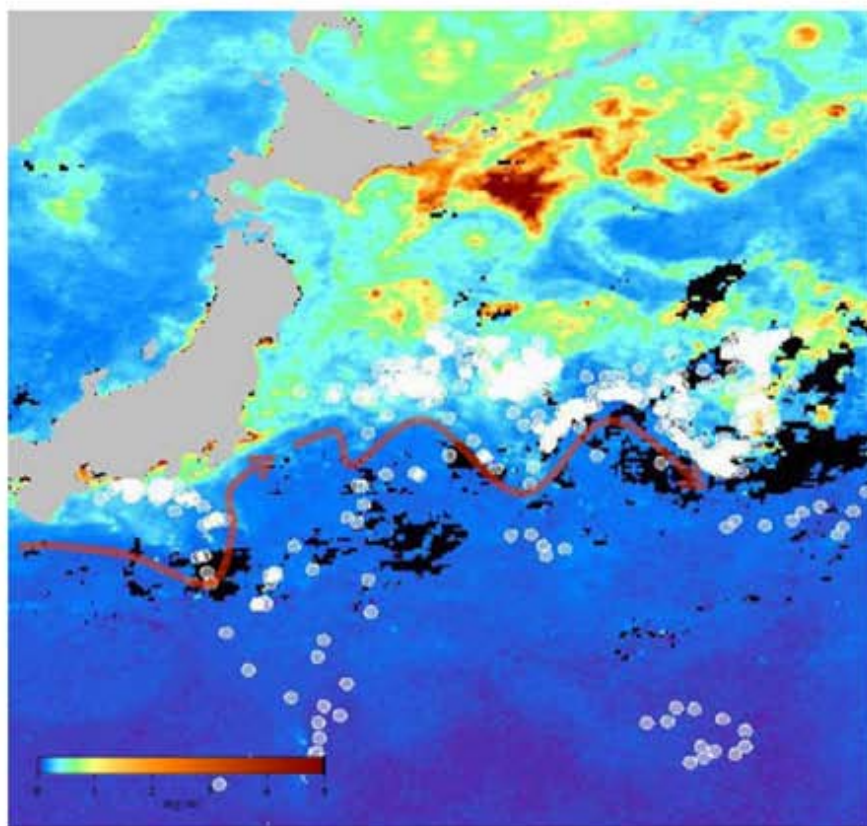

Chlorophyll-a concentration in the northwestern Pacific in June 2003 overlaid on fisheries of skipjack and tuna.

The fisheries of skipjack and tuna, warm-water migratory fish, appear to be influenced by the Kuroshio warm current and its extensions offshore Sanriku.

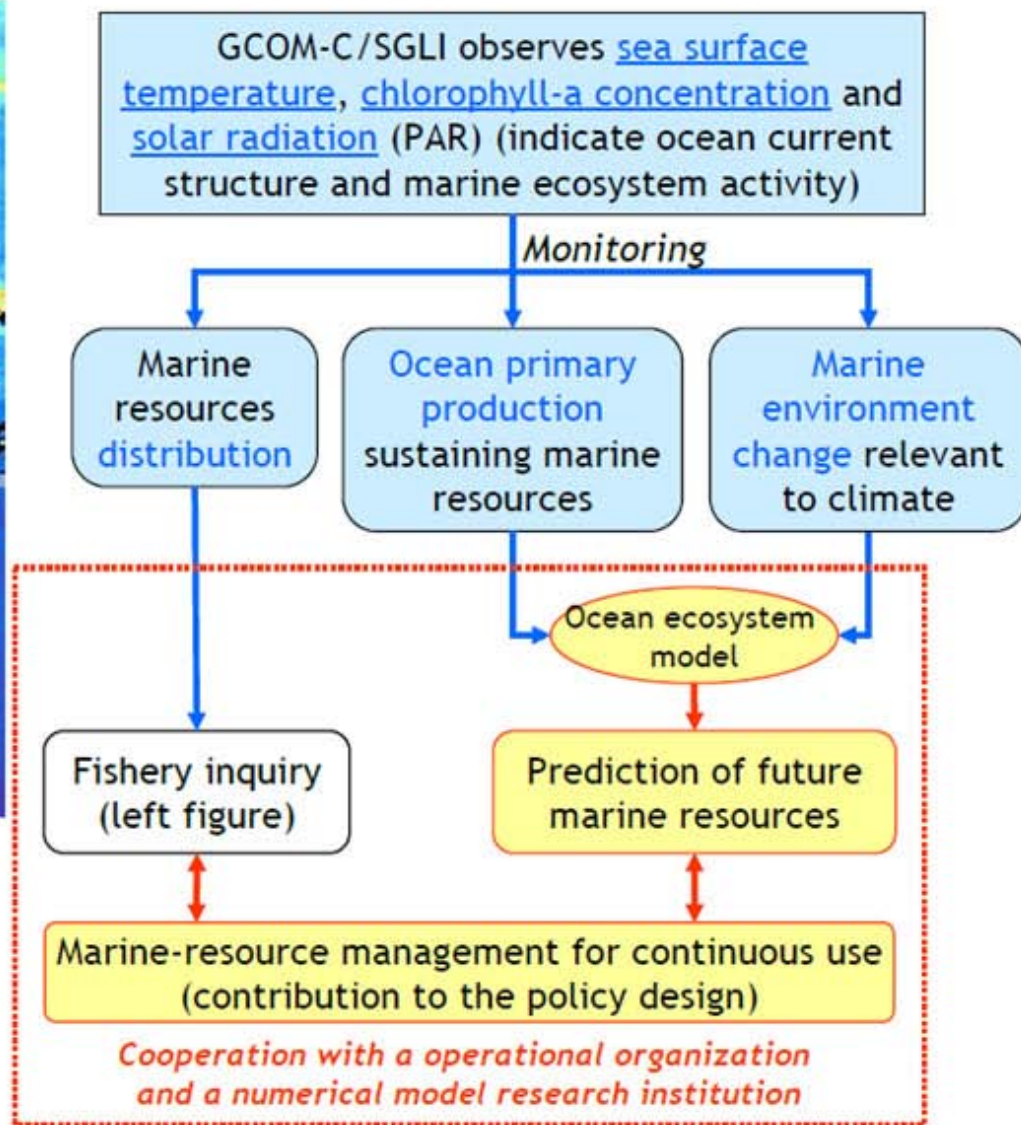

Recent status of GCOM-W1

- Project status
 - GCOM-W1 was approved to move to development phase (by SAC on August 8, 2007).
 - PDR was finished in June, 2008.
 - AMSR2 CDR1 was finished on July, 2008.
 - AMSR2 deltaCDR was held on November.
 - System CDR was finished on Oct, 2009.
 - AMSR2 PQR was finished on Sep. 2010
 - GCOM-W1 PQR was finished on June, 2011
 - Current target launch date is Feb. 2012.

Recent status of GCOM-C1

- GCOM-C1 is under phase B.
- GCOM-C1 was approved to go to a project within JAXA on July, 2008.
- SGLI PDR was finished on Dec. 2009.
- GCOM-C1 PDR was finished on Oct. 2010.

Research Announcements

- First RA for GCOM-W1 was issued on Jan. 2008.
- 35 PIs were selected.
- First GCOM Symposium/Workshop was held on 13-15, Jan. 2009 in Yokohama.
- First GCOM-C1 RA was issued on January, 2009. 28 PIs were selected.
- PI workshop including GPM & EarthCare PIs was held on Dec., 2010.
- Second RA for GCOM W1 is under review.

International Cooperation

- Discussions on the cooperation with NPOESS is underway with NOAA
- JAXA is proposing a joint science activity with NASA
- Provision of a scatterometer on GCOM-W2 is under discussion with JPL and NOAA

New Scatterometer on GCOM-W2

- Dual Frequency Scatterometer (DFS)
- Ku band and C band
- around 2m aperture
- All weather monitoring
- All wind speed monitoring

AMSR3 on GCOM-W2

- Addition of scatterometer
- Addition of high frequency channels (150-190GHz) for solid precipitation and water vapor sounding
- Also, join the A-train at least 1 year

GCOM-W2 Overview

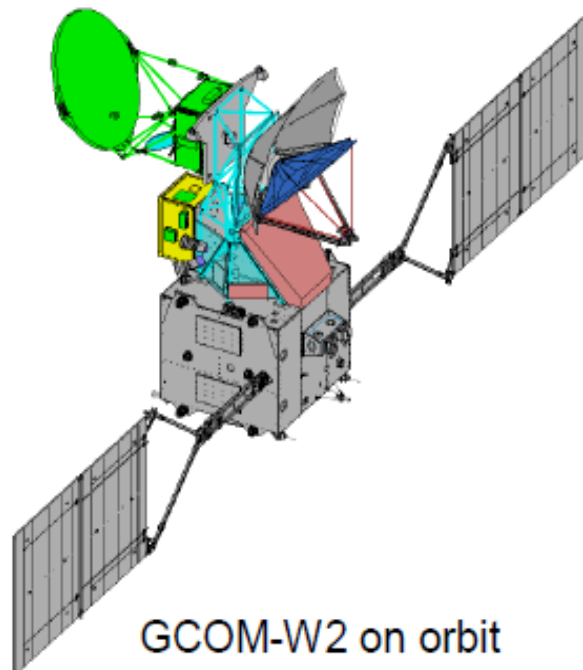
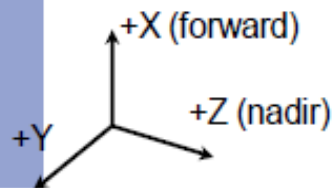

GCOM-W2 Overview

Mission instruments	<ul style="list-style-type: none"> • Advanced Microwave Scanning Radiometer 3(AMSR3) • Dual Frequency Scatterometer (DFS)
Observation orbit	Sun Synchronous Orbit (A-train orbit) Altitude 699.6km, Inclination 98.186deg
Local sun time	13:30 (ascending)
Dimensions	5.6m(X), 17.6m(Y), 5.2m(Z)
Spacecraft mass	2515kg (BOL)
Generation power	4050W (EOL, two wings)
Launch year and launcher	January 2016 / H-IIA
Design lifetime	Five years

GCOM-W2 Configuration

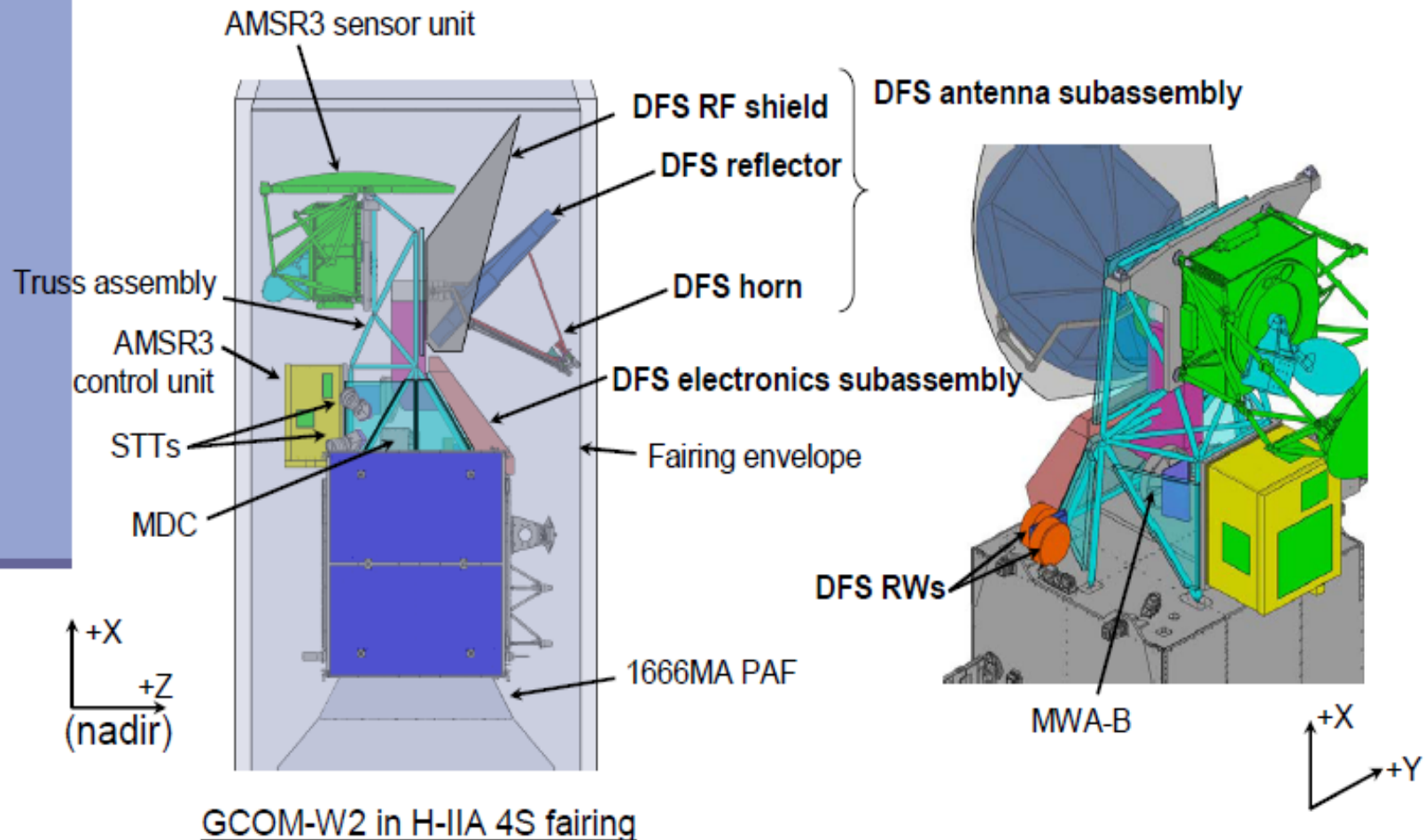

Conclusions

- AMSR2 will have the highest calibration capability within microwave imager.
- AMSR-E products will be reprocessed after the cross calibration with AMSR2.
- Long term high accuracy microwave imager products will be obtained.

Basic Law on Space

- Basic Law on Space has passed the Parliament last June
- Strategic Headquarters has been established (Minister level)
- All the space activities will go under the Cabinet Office
- Restructuring of JAXA
- Increased budget?

Influence of Great East Japan Earthquake

- GCOM-W1 PFM received no damage.
- Testing facilities have some damage.
- Testing facilities are now reopened.
- Launcher also received some damage.
- The new launch date is later than 14, Feb. 2012.