

The line drawings, etc., which have been made to illustrate the mechanism and to aid in the description of the machine, embrace Figs. 129 to 147. In connection with the present machine it will probably be best to examine some of the details first, and then to show the complete views when a general idea of the chief parts is understood. The uncut roll of paper A, Fig. 129, is placed on the wooden roller B, and carried over the peg cylinders C and D; it is then brought down to the wooden roller E, and secured to it by means of a thin iron rod which fits into a corresponding groove in the roller.

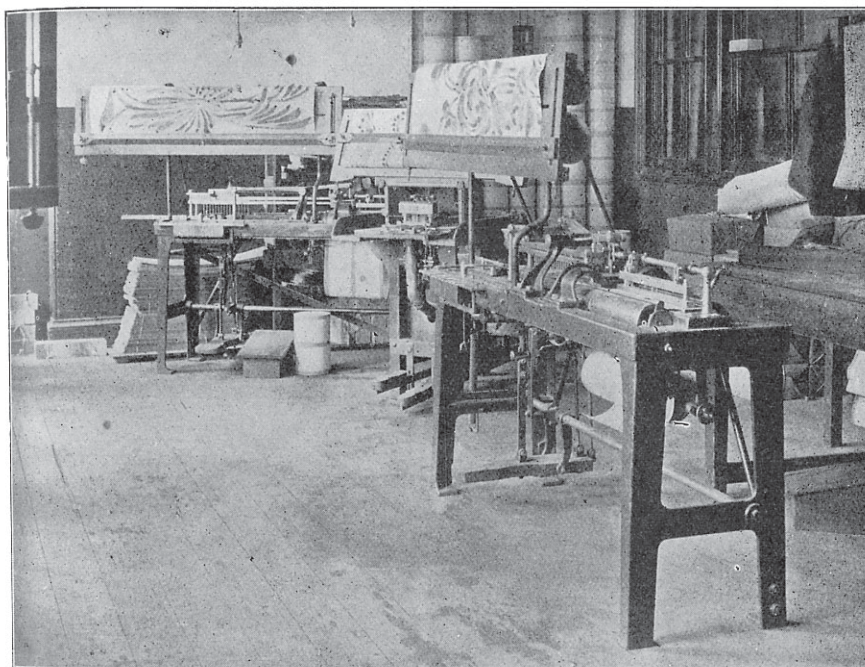

FIG. 128.

In the machine illustrated in Figs. 123 to 126 it was shown that the paper remained stationary until the cutting of the card was complete, when the paper was carried round to present the next blank portion, *i.e.* the equivalent of a card, in position. In the machine under notice we might mention that the card or paper itself moves sideways after each cut in a manner similar to that which takes place in the ordinary pitch piano machine. In addition to this sideways movement, the paper must be well under control so that it may be moved lengthways after each card or its equivalent has been cut. And it need hardly be pointed out that it is necessary to provide means for moving the paper backwards as well as

forwards ; it is, as a matter of fact, desirable and essential that the paper may be turned in either direction at will for any number of cards. The mechanism for these movements lengthwise—*i.e.* the movement imparted to the paper by the cylinders—shall be described first.

On the end of the peg cylinders C and D, Figs. 130 and 131, seen clearly in the latter view, are two pairs of plain discs—F and G for cylinder C, and H and J for cylinder D. The two pairs of discs F and G are kept at the

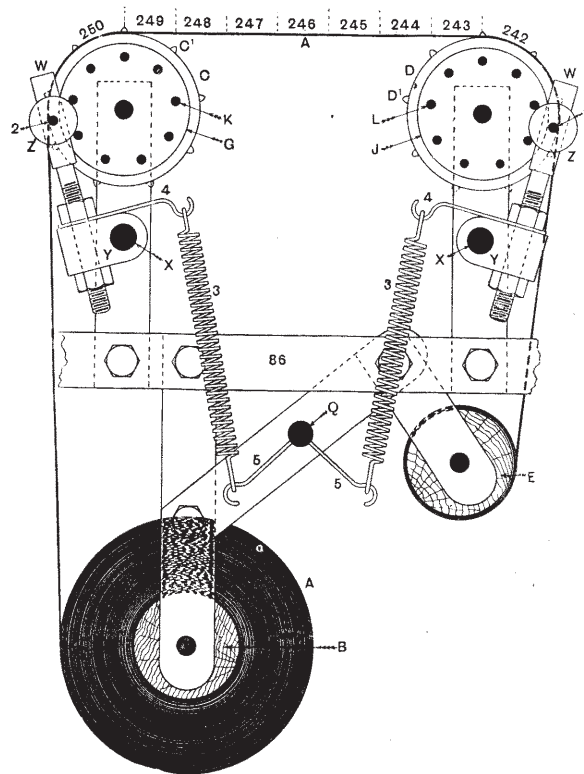

FIG. 129.

proper distance apart by nine pins K ; and similarly the discs H and J are kept apart by the nine pins L. These pins serve two purposes, as by means of them the cylinders C and D are rotated, while after having been rotated through one-ninth of a revolution the pins provide means in conjunction with other parts for keeping the cylinders steady.

A double-hooked flat bar M, Fig. 130, is supported by a pin N which is held by the flat bars O. These two flat bars are riveted to a short arm of the L-shaped lever P fulcrumed on the stud Q. This short arm and the two bars O thus form a kind of fork. The long arm of lever P passes through a

slotted bracket R, and is provided with a suitable handle S. Two springs T and U are set-screwed to the bars O so that each spring may tend to keep its respective end of the hooked bar M in the highest position—*i.e.* in close

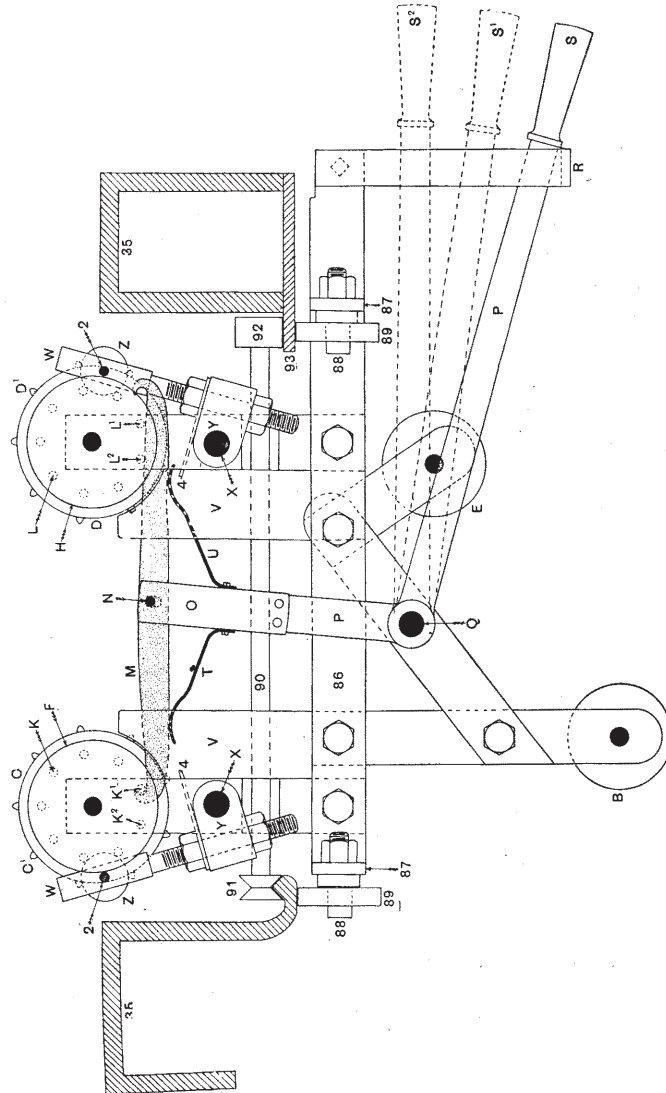

FIG. 130.

touch with the pins K or L, as the case may be. The necessary free movement of the hooked bar M is provided for by a slot in the centre of the bar which allows the latter to oscillate slightly on the pin N.

With the handle S in the lowest position, shown in solid in Fig. 130, it

M

is clear that the left-hand hook of the bar M will be in its extreme right position, and must therefore have pulled the pin K^1 so as to turn the cylinder C counter-clockwise through the distance of one card or pin. It will be observed that the right-hand hook of the bar M is quite clear of all the pins L. If the handle S be raised to the central position, shown at

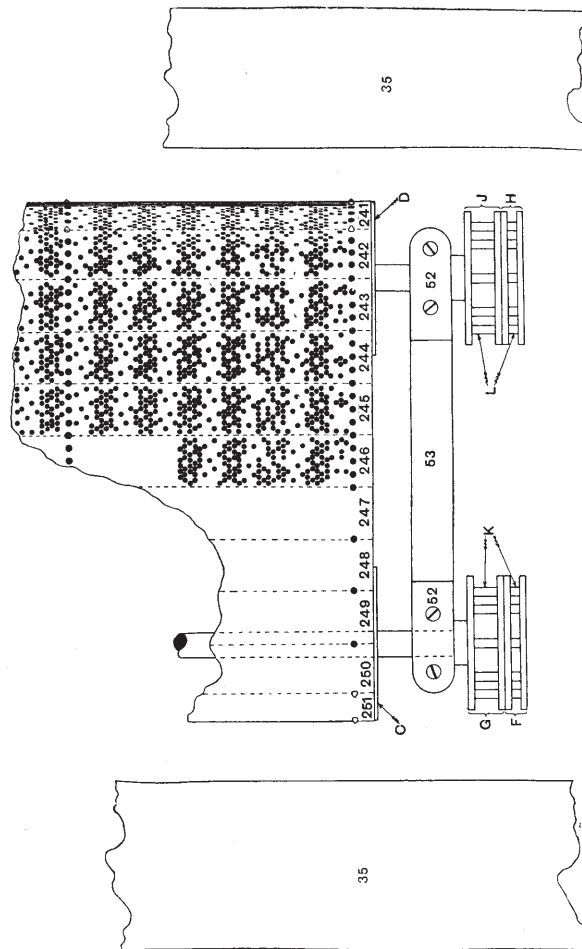

FIG. 131.

S^1 in dotted lines, the hooked bar M will be moved to the left; the right-hand hook will then have reached the next pin L^1 , and the left-hand hook will have left the pin K^1 and will have slipped over the pin K^2 , the spring T yielding to allow this. A further upward movement of the handle S from S^1 to S^2 will clearly cause the right-hand hook of bar M to pull the pin L^1 to the position at present occupied by the pin L^2 , and hence will rotate the

cylinder D clockwise through the distance of one card, or one pin. This movement will also result in the left-hand hook of bar M being taken clear of the pin K²—*i.e.* to a position corresponding to that occupied in the figure by the right-hand hook—and then this cylinder is free to rotate in the same direction as the other. The inoperative position of the handle S and all connecting parts is when the handle occupies the middle position S¹.

The two cylinders always move in unison, and thus carry the paper A, Fig. 129, forwards or backwards as desired, and of course for any number of successive cards in either direction. The hooked bar M, Fig. 130, slides between two pairs of supporting guides V so as to keep the hooked ends centrally situated between the discs F, Fig. 131, and the discs G respectively. Whichever way the cylinders C and D have turned, it is absolutely necessary that they should be forced into their proper positions, and then held there firmly during the whole time that the card is being cut. This essential condition is achieved by the action of the spring hammer W, fulcrumed at X, Fig. 130.

These parts will be more clearly seen in Fig. 129, where they are complete, and in which figure both discs F and H, Fig. 131, have been omitted, and so have the outer discs of G and J in order to show up the parts to advantage; the pins of G and H, however, are shown in Fig. 129. The spring hammer consists of the bolt W adjustable in the swinging bracket Y by means of the lock-nuts, and an anti-friction pulley Z fulcrumed at 2 in the bolt W. This apparatus is somewhat similar to and performs the same functions as the spring hammers in a jacquard machine—*i.e.* when the cylinder is rotating and has nearly reached its proper position, it is forced there by the pressure of the pulley Z through the action of spring 3 connected to hooks 4 and 5, the latter of which remains stationary.

The mechanism just described, which occupies the upper part of Fig. 130, is situated in a position approximately midway in the machine, but is capable of moving a distance equivalent to the length of the longest card which is used on the fine-pitch jacquard machines. The view of the mechanism in Fig. 130 is taken as looking towards the discs of the cylinders C and D, while the lower part of the same figure and Fig. 131 constitute one plan view of a part of both cylinders C and D and a number of cut and uncut cards bridging the gap between the two cylinders. We shall refer to Fig. 131 later.

We might now with advantage see how the piano keys operate the various rods and levers for the punches, and also see how the latter are operated in the headstock. The parts for this demonstration are illustrated in Figs. 132 to 136. Fig. 132 is a view of the headstock looking towards the discs of the cylinders C and D; the punches in the headstock are

arranged in two rows to cut holes in the card in the zigzag order as usual, and as illustrated in the small detached view at the bottom of the figure. There are two sets of punches, long ones 28 and short ones 27, enlarged views of which appear in Fig. 133 ; they are arranged as such simply for

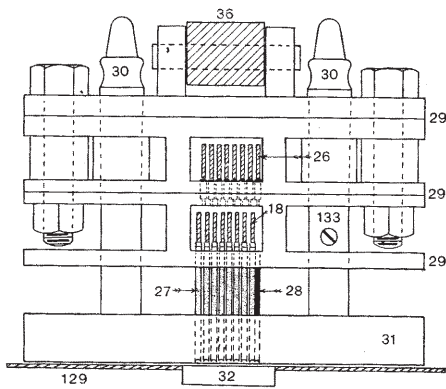

Fig. 132.

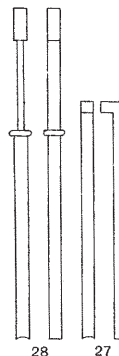

Fig. 133.

convenience, and the method of bringing each set into action is somewhat similar to that illustrated in Figs. 115 and 116.

Figs. 134 and 135 are side views of the headstock taken from the front of the machine ; these figures also show the connections to one of the rods

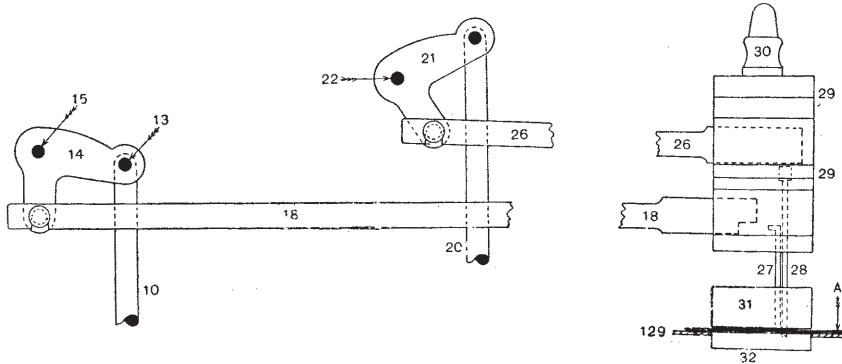

Fig. 134.

10, which is actuated directly from the piano-key lever 7, Fig. 136. Both rows of holes shown at the bottom of Fig. 132, or as many as are required in the two rows, are cut at the same time ; hence 16 piano keys with their corresponding levers and other connections are essential. Two sets of connections are shown in Figs. 134 and 135, but one piano key only is shown at 6, Fig. 136, while its position when pressed down is represented by the

dotted part 6¹. The key is fixed to one end of the key lever 7, fulcrumed at 8. The back end of the lever 7 is weighted as indicated at 9, so that the parts have always a tendency to keep the key 6 in its highest position, and they do so when the operator's finger is lifted from the key.

The lower end of an upright rod 10 passes through a hole near the weighted part of lever 7, then through holes in the table and in the horizontal plate 11 supported by two pillars 12. At a point immediately above the plate 11 the rod 10 is bent almost at right angles, Fig. 136, and then attached at 13, Figs. 134 and 135, to the bell-crank lever 14 fulcrumed at 15. The bell-crank lever is supported by and free to turn slightly in the slotted or forked plate 16, Fig. 136, which depends from the plate support 17. The exact position of the rod 10 with regard to its influence on the long bars 18 (shown broken in Figs. 134 and 135) is regulated by means of the lock-nuts 19, Fig. 136.

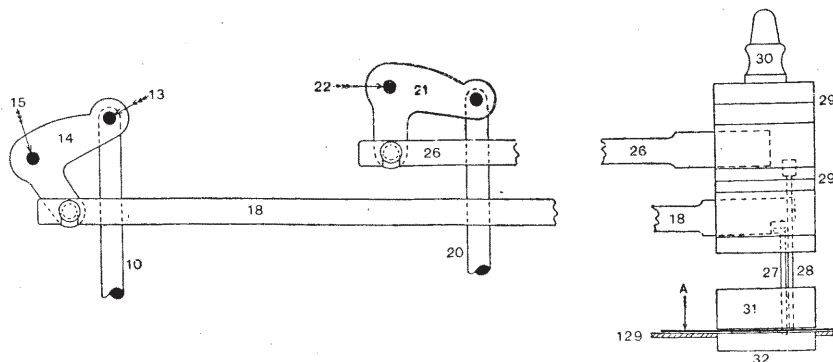

FIG. 135.

In the complete set there are 8 such rods 10, and these are operated by the first eight piano keys to the left of the machine. The next eight piano keys—*i.e.* Nos. 9 to 16—operate precisely similar levers to 7; but the rods 20, which correspond to and play the same part as rods 10, are bent at a bigger angle immediately above the plate 11, in order that they may be attached to the upper set of bell-crank levers 21, fulcrumed at 22. In Fig. 136 one of the rods 20 is also shown in its highest position at 20¹. The bell-crank levers 21 are also supported by forked plates 23 (see Fig. 137), which in turn depend from the horizontal plate support 24. The two plates 17 and 24 are supported by pillars 25. Attached to bell-crank levers 21, Figs. 134 and 135, are eight long bars 26 very similar to those marked 18, but occupying a higher plane. The horizontal plate supports 17 and 24, Fig. 136, are in reality joined, but they occupy different heights because the respective parts which they support have to operate the higher and lower sets of long bars 26 and 18, Figs. 134 and 135.

The free ends of bars 18 and 26 enter suitable recesses in the headstock (see Figs. 132, 134, and 135). Inside the upper recess is a grate which guides the free ends of the long bars 26 over their respective punches 28, Fig. 133, while the free ends of the lower long bars 18 are guided somewhat similarly over the tops of the short punches 27 in the lower recess, and pass between

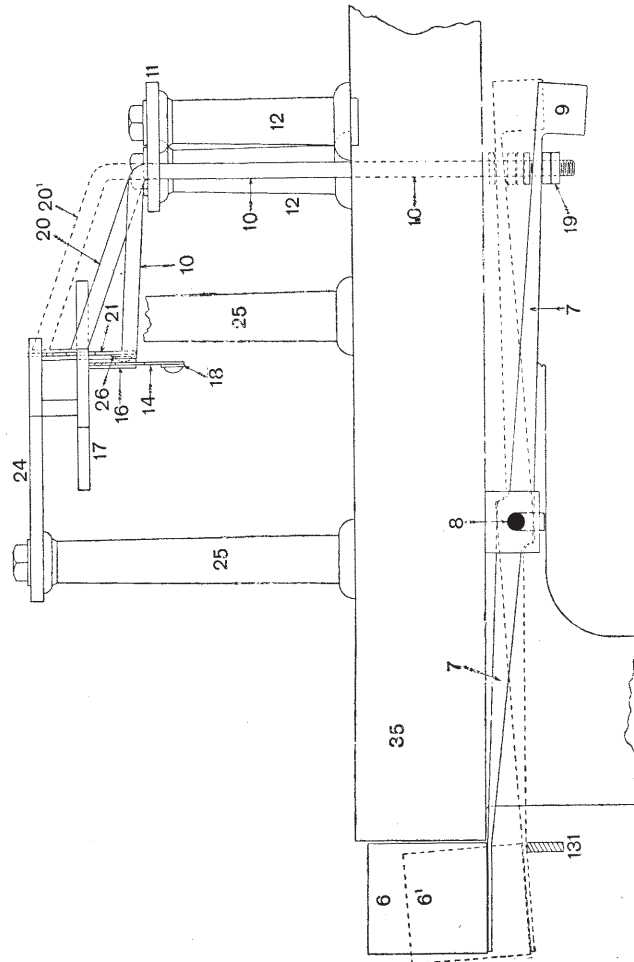

FIG. 136.

the thin parts of the long punches. The views of the long punches in Fig. 133 will show that this is possible. It will be evident that when the bell-crank levers 14 and 21, Figs. 134 and 135, are raised in virtue of the downward movement of the corresponding piano keys 6, Fig. 136, the long bars 18 and 26 will be carried forward—*i.e.* to the right in Figs. 134 and 135—and their extreme free ends will be placed respectively over the top of one

short punch 27 and one long punch 28. In Fig. 134 the lower long bar 18 is in its normal position—*i.e.* with the piano key up—whereas the upper long bar 26 has been moved about $\frac{9}{16}$ in. to the right by the bell-crank lever 21, because the corresponding piano key 6, Fig. 136, has been pressed down and the rod 20 raised. The end of the long bar 26, Fig. 134, is consequently over a long punch 28. In Fig. 135 the conditions are reversed—that is, the end of the lower long bar 18 is over the top of a short punch 27, while the upper long bar 26 is in its normal position.

In Fig. 134 it will be seen that the long punch 28 has been forced through the card or paper A, and the short punch has remained stationary on the paper while the plates 29 of the headstock have moved downwards to their lowest positions. Conversely, in Fig. 135 the short punch 27 has been forced through the paper, while the long punch 28 was unaffected. The plates 29 of the headstock move up and down on two pillar-rods 30 under the influence of the treadle and intermediate connections. Plate 31 is a guide plate or block, and the paper A is cut between this plate and the lower plate 32.

Fig. 137 is a front elevation of the complete machine; Fig. 138 is an end elevation looking from the left of Fig. 137; Fig. 139 is an elevation of the opposite end; Fig. 140 is a complete plan; while Fig. 141 is also a plan, but with certain parts removed to show details of the mechanism more clearly. In these views the keys are in solid black and stippled alternately, to facilitate the fingering; and in order to enable one to follow the connection, the rods 10 and 20 are similarly marked, although it must be remembered that the rods 10 and the first eight keys operate one row of punches, while the rods 20 and the other set of keys operate the other row of punches. The point-paper design, as already indicated, is pinned on the board 33 with the first thread of the design on the left, and the first pick at the bottom. In this particular machine the reading board is supported by brackets 34 fixed to any convenient part of the table or frame 35 (see also Fig. 128).

The downward movement of the plates 29, Figs. 138 and 139, of the headstock is due to the similar downward movement of the end of the short arm of lever 36, Figs. 137 and 141, fulcrumed on a pin 37, and between the two brackets 38; the latter are bolted to the top of the table 35. A pin or stud 39 connects the long arm of lever 36 with a small bracket 40 on the upper end of rod 41. The rod 41, Figs. 137 and 138, is attached to a forked bracket 42 near the end of the treadle 43, and the latter is fulcrumed on a pin 44 held by two brackets 45. From these connections and parts it is obvious that when the end of the treadle 43 is depressed, the plates 29 of the headstock will descend. The upward movement of the treadle and of the plates of the headstock is obtained by the action of the spring 46, Figs. 138 and 139. This spring encircles the rod 47, which is connected to the bracket

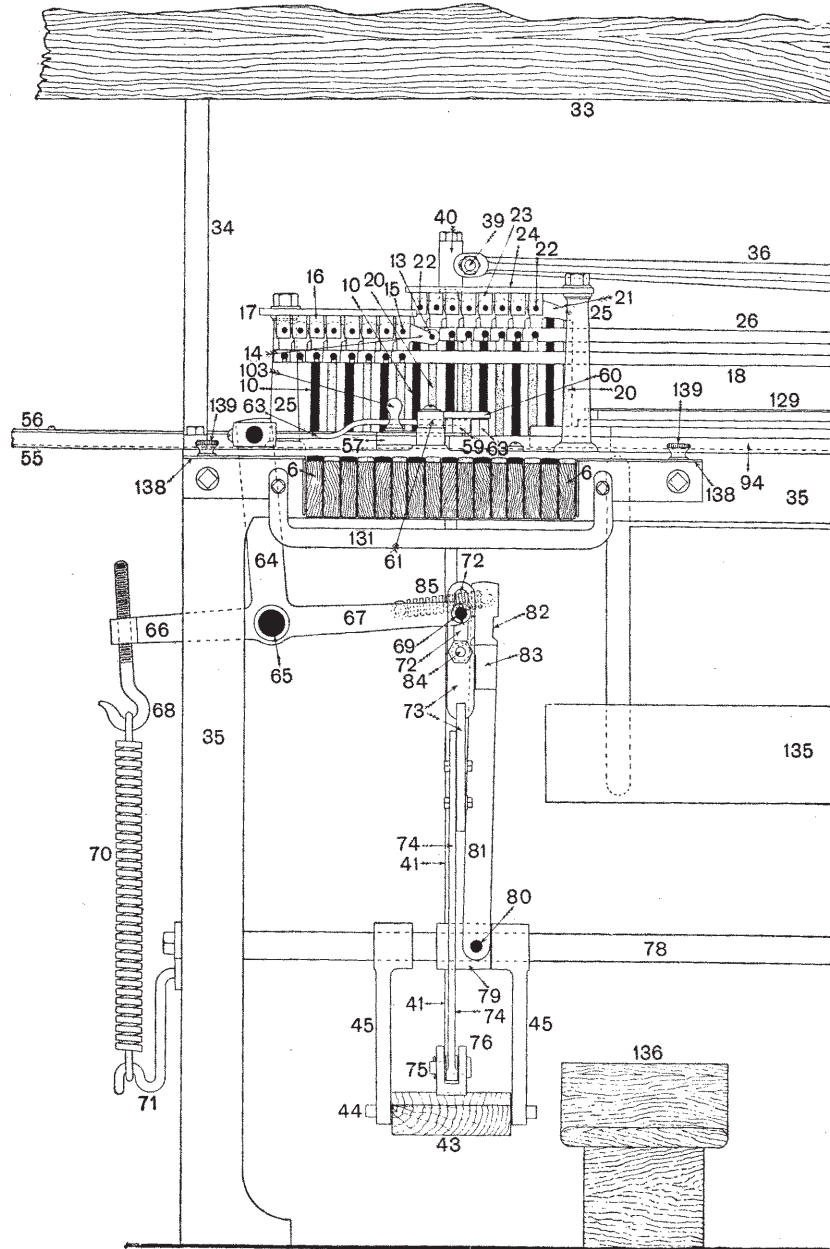

FIG. 137.

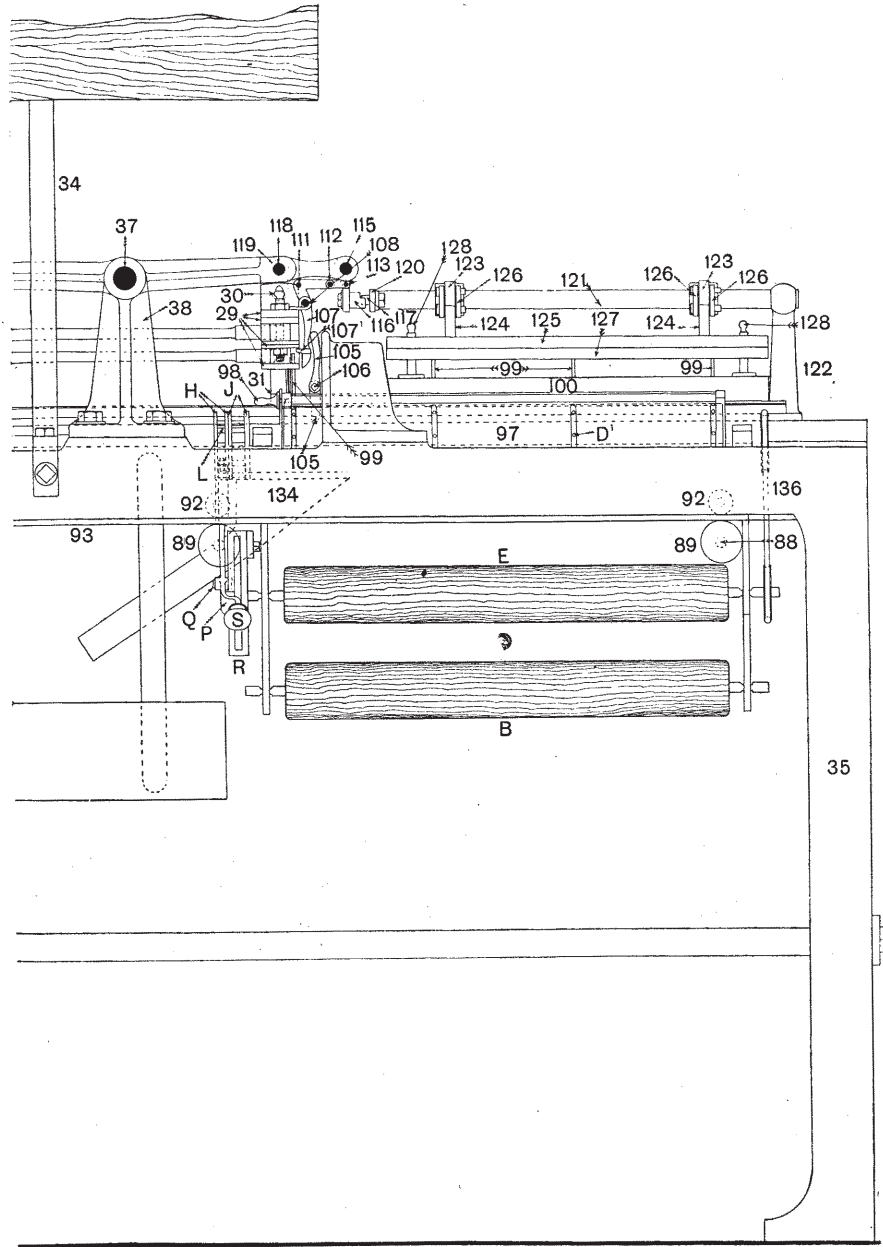

FIG. 137.

48 on a stud 49; the latter projects from the rear end of the treadle 43.

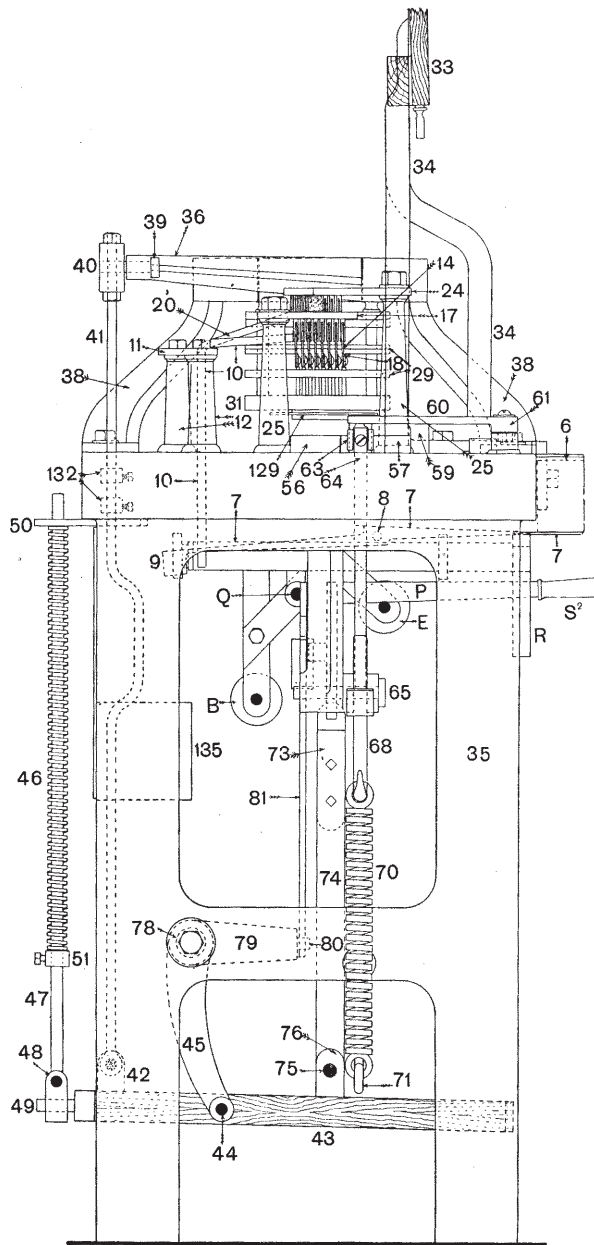

FIG. 138.

Before the above action of drawing the cylinders, etc., to the left takes

The upper end of rod 47 passes through a hole in the plate 50, which is bolted to the underside of the table, and thus acts as the upper check to the spring 46. A collar 51 can be adjusted on the rod 47 to enable the spring to possess the necessary force for returning the treadle 43 and plates 29 of the headstock safely to their highest positions.

It will be understood from what has been said that the necessary holes in two zig-zag rows of the paper are cut at each downward movement of the plates of the headstock, and that after such movement, and before the next downward movement takes place, the paper, together with the two cylinders C and D, Fig. 129, and all other essential connections, must be drawn forwards or to the left in Figs. 137, 140, and 141, a distance equal to the space occupied by two rows of holes.

place, it is necessary that the ends of all punches 27 and 28, Fig. 132, which for the moment are through the paper, should be raised clear of the paper, otherwise it is quite evident that the punches would tear the paper. The mechanism which is introduced to delay the movements of the above parts until the punches are safely withdrawn from the paper, works in conjunction with and by the action of the treadle 43; it is illustrated in Fig. 131 and Figs. 137 to 141. The two cylinders C and D are supported in suitable bushes in the brackets 52, the two pairs of brackets being connected by cross-rails 53. One end of the rack 54, Fig. 141, is bent at right angles and bolted to the nearer cross-rail 53, or it may be connected to both cross-rails as illustrated. The rack 54 slides on the base of the rack guide case 55, which may be closed at the base, or part may be cut away just as desired. In either case, the cover 56 is screwed to the top of the case.

In Fig. 141 the cover of the case is omitted, and so is the cover of the

pawl box 57, in order to illustrate more clearly the function of the mechanism. The pawl 58, which imparts motion to the rack 54, is fulcrumed at 59 near the middle of lever 60, which in turn is fulcrumed at 61. The other end of lever 60 is attached at 62 to the bar 63, and the opposite end of bar 63 is forked to receive the end of the vertical arm 64, Figs. 137 and 138, of a three-armed lever fulcrumed at 65. The two horizontal arms 66 and 67

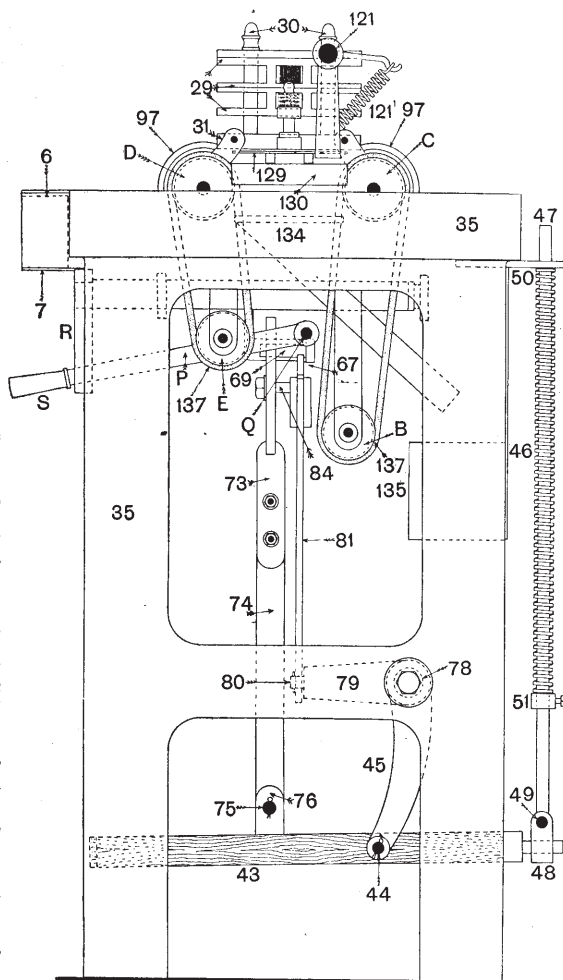

FIG. 139.

are attached respectively to the screwed hook 68 and the stud 69. The

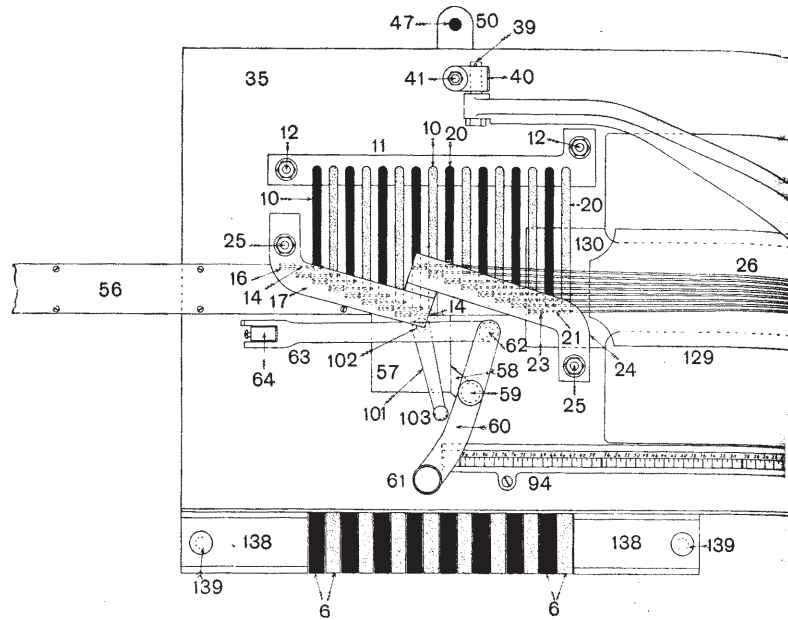

FIG. 140.

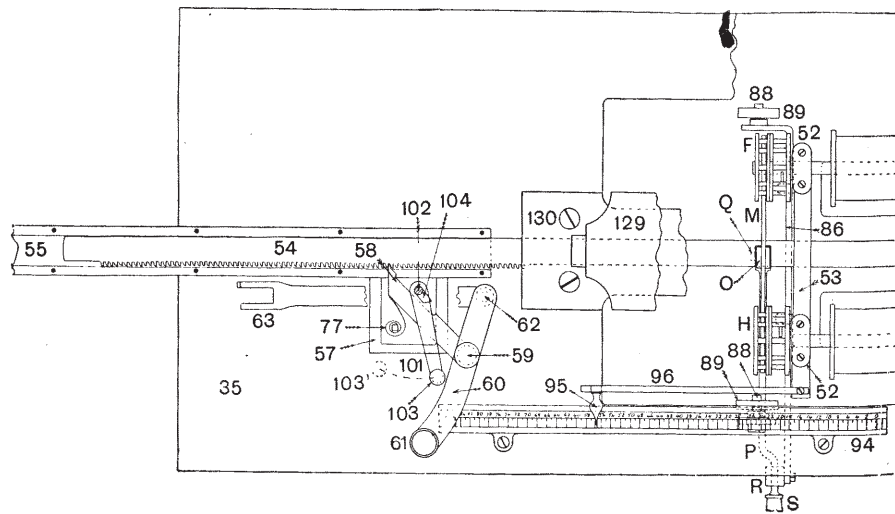

FIG. 141.

hook 68, and therefore the three-armed lever 64, 66, and 67, Fig. 137, are kept in the position shown by the action of spring 70, and the latter is

hooked as shown to 68 and to the bottom hook 71, which is bolted to the frame. The stud 69 projects from the side of the lever 67 and enters the

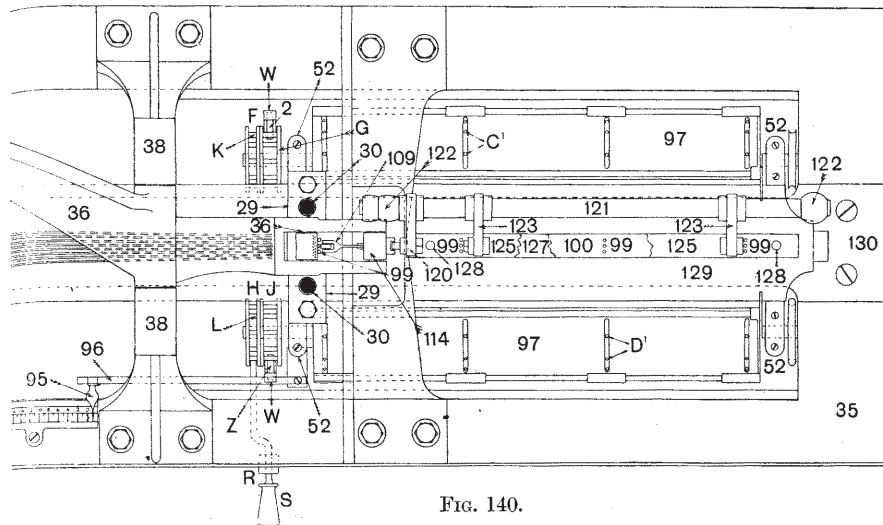

FIG. 140.

slot 72 in the bar 73. The latter is bolted to the bar 74, so that means of adjusting the combined length of the two are provided. The lower end of

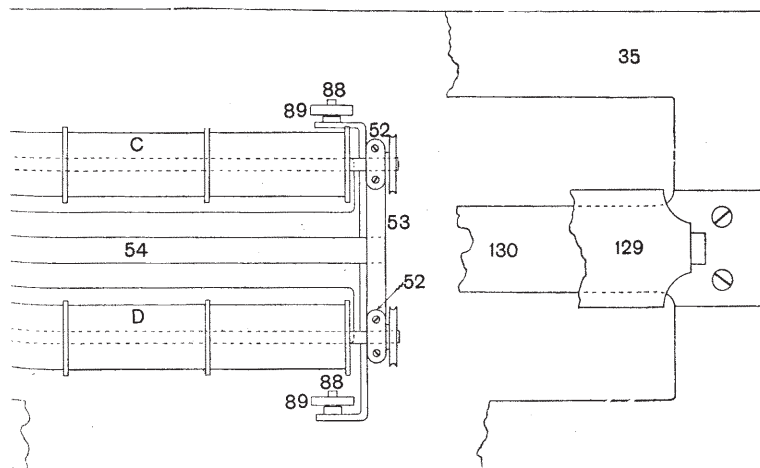

FIG. 141.

bar 74 is held by a pin 75 in a forked bracket 76, and the latter is securely fixed to the upper surface of the treadle 43.

After the operator has selected the proper keys 6, Figs. 137 and 140, according to the marks on the 16 vertical rows of the design-paper, she presses the keys down, and from what has been said it is clear that the free ends of the corresponding long bars 18 and 26 will cover their respective punches. She then depresses the treadle 43, which, in addition to causing the punches to pass through the paper, will evidently rotate slightly the three-armed lever 64, 66, and 67 clockwise. The upper end of the vertical arm 64 will thus cause the bar 63, Fig. 141, and through it the pawl 58, to move to the right, taking the pawl 58 from the position shown in Fig. 141 to the position occupied by the next tooth on the right. The pawl 58 is kept in touch with the teeth of the rack 54 by the scroll spring 77. It is quite evident that when the operator releases the pressure on the treadle 43, the spring 46, Figs. 138 and 139, will bring back the treadle to its highest position, and, as previously mentioned, will also cause the punches to be raised clear of the paper. It is equally evident that the three-armed lever, as well as the rack, would move at the same time unless special provision were made to prevent it. The arm 67, Fig. 137, of the three-armed lever must remain in its lowest position until the punches have been raised safely into the block 31. This requirement is obtained in the following manner: Projecting from the stay rod 78, upon which the brackets 45 are fixed, is a bracket 79. A stud 80 projects from the face of bracket 79, and upon this stud is placed the lower end of the flat bar 81. The upper end of this bar is recessed at 82 as shown, and at both sides, although one side only can act. A small plate 83 is riveted to bar 81. A stud 84 is fixed to the lever 73 near the bottom of the slot 72, and a spring 85 joins the upper end of bar 81 to the lever 67, the former being thus kept in close contact with the various parts. As the treadle 43 is descending, the top part of the slot 72 approaches and ultimately comes in contact with the stud 69 in the lever 67. The stud 69 therefore begins to move in unison with the bar 73 until it has descended sufficiently far to allow the recess 82 to slip over a corresponding part in the stud 69—the spring 85, of course, drawing the bar 81 with the recess into contact.

With the upward movement of the treadle 43 the bar 73 rises, but the stud 69, and therefore the three-armed lever, is unaffected until the stud 84 comes in contact with the curved part of 83. Any further upward movement of the stud 84 will force the bar 81 outwards through the projecting part on piece 83, and thus release the stud 69. Immediately the latter is free to move, the spring 70 pulls down the arm 66, and therefore moves the bar 63, Fig. 141, and the pawl 58 to the left. This will clearly enable the pawl to take the rack with it, together with the two cylinders, paper, and all connections, a distance of one tooth or two zigzag rows.

The cylinders C and D, Fig. 141, and all connected parts are capable

of being moved the full length of the cut portion of the longest cards, or rather widest paper; and in order to enable this movement to be conducted with accuracy and with as little friction as possible, eight anti-friction pulleys (six plain pulleys, and two V-grooved pulleys) are employed. The arrangement of the pulleys is best seen in Fig. 130, where the cylinders and all parts are shown connected directly or indirectly with the flat bar 86. At the correct distance apart on the flat bar 86, and at right angles to its face, are two projecting parts 87, which are provided with pins 88, upon which rotate two of the anti-friction pulleys 89. Parallel to the bar 86, and in a higher plane, is a small shaft 90 on one end of which is a V-grooved pulley 91, and on the other end an anti-friction pulley 92. The two pulleys on the right, 89 and 92, rotate against the lower and upper surfaces of a plate 93, which is bolted to the frame and projects as shown; while another pulley 89, on the opposite or left side in the illustration, rotates against the underside of a specially shaped part of the frame 35, the upper surface of this part being made in the form of an inverted V, and on which runs the V-grooved pulley 91. A similar set of four pulleys is arranged near the end of the cylinders C and D; the grooved pulleys 91 prevent any side movement on the part of the mechanism, and thus enable the cutting to be accurately spaced.

The number indicator 94, Figs. 140 and 141, is screwed to the top of the table 35; and as the cylinders move after each two rows have been cut, the pointer 95, which is attached to the cylinder support 53 by the narrow flat bar 96, moves in unison with the remaining parts, and indicates the rows which are under the punches 27 and 28.

The roll of paper is usually delivered with peg holes cut between each pair of cards as illustrated in Figs. 142, 143, and 144; such paper is made by French and German as well as British firms. The cards in Figs. 142 and 143 are reduced to two-fifths of the actual size, and are for 896's jacquards, while the card in Fig. 144, shown one-fourth the actual size, is for a 1344's jacquard. In all three cases the foundation of the strengthening strips is cloth. In Figs. 142 and 143 a scrim made from high-count cotton yarns in a low sett is used, and this is fixed on to the strengthening strip paper before it is attached to the proper paper—probably in wide widths and then cut up into strips of the proper width. In the strips of the card in Fig. 144 the foundation cloth is made from high-count cotton yarns in a comparatively fine sett, and then this cloth is heavily loaded, and finally embossed to represent a twill cloth. The advantage of the card in Fig. 143 is that the position of every needle in the jacquard machine or hole on the paper is printed on the paper, and hence this improvement facilitates the location of the position of any needle of the jacquard machine or square of the design-paper.

Before placing the paper over the cylinders C and D it is necessary to swing back the brass covers 97, Figs. 137 and 140, which, when in position, are concentric with the peripheries of the cylinders, and are held there securely by a long rod at the end of which is a small handle 98. The

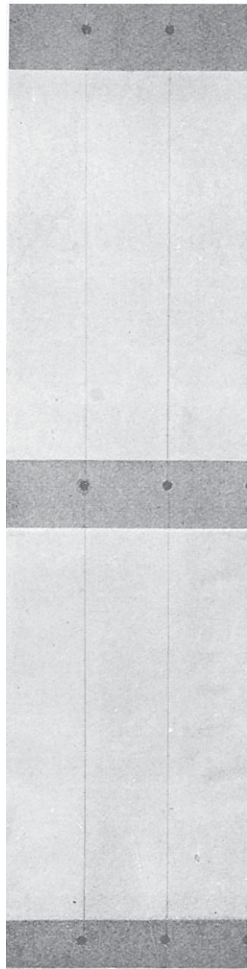

FIG. 142

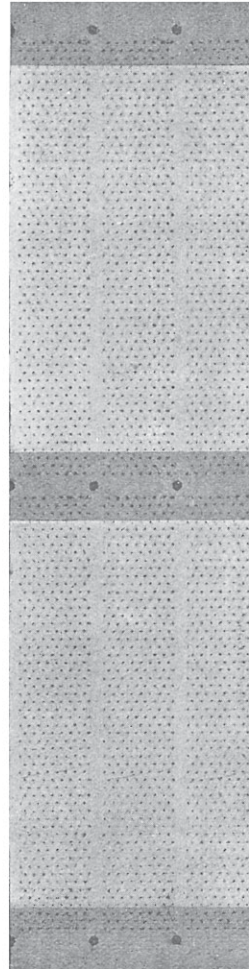

FIG. 143.



FIG. 144.

withdrawal of this handle about $\frac{1}{2}$ in. liberates the upper head of the cover from the side brackets, and since the covers are hinged at the lower edges they may then be easily turned outwards.

The pitch of the paper, or rather the width required for each card, and the pitch of the holes in the paper illustrated in Figs. 142, 143, and

144, are the same as the pitch of the pegs C^1 and D^1 on the circumferences of cylinders C and D, Fig. 130. When the design is cut on the card as illustrated in Fig. 122, there are three additional peg holes on each strengthening strip for each card. These extra holes are for use on the jacquard machine if from any cause the normal ones, or those shown in Figs. 142, 143, and 144, become damaged, and these extra holes are cut in the piano card-cutting machine. For a 1344's jacquard machine there are four strengthening strips on the paper, see Fig. 144; consequently the piano machine must be provided with four sets of peg punches, three punches in each set. These are shown at 99, Figs. 137 and 140. Three of the sets are in the peg-hole punching block 100, while the remaining set is in the headstock and immediately to the right of the two rows of ordinary punches 27 and 28.

In order to make the description of the operation of cutting as simple and intelligible as possible, we shall imagine that the last row of one card has been cut, and that therefore the cylinders C and D, Figs. 137, 140, and 141, and all connected parts, will be at the extreme left position, with the index pointer 95 over the last mark on the scale. This done, it is now necessary to move the cylinders, paper, etc., to the other extreme end, or starting point, but before this can be done the pawl 58, Fig. 141, must be withdrawn from contact with the rack 54. A lever 101, fulcrumed at 102, is provided with a small handle 103. A small cam 104, integral with the lever 101, is also on fulcrum 102; and when the handle 103 is moved to the position indicated by 103¹, the cam 104 will have forced out pawl 58 quite clear of the teeth of the rack 54.

The position occupied by the cam 104, when the handle 103 is rotated to the point marked 103¹, is such that the pawl 58 cannot be forced in by the scroll spring 77, since the force of the latter against the cam is directed through the fulcrum 102.

The treadle 43, Figs. 137, 138, and 139, is kept down when the last row in the card or paper has been punched; then the operator turns the small handle 103, Fig. 141, as described, to release the pawl, lifts up the handle S, Fig. 130, from the central position S^1 to the top position S^2 , which rotates the cylinders C and D towards the operator, or in what we have termed the forward direction, and brings the next blank card into position; finally she pushes the handle S to the right in order to place all parts at the other extreme end ready for the cutting of the next card.

There is a small projection fixed to a convenient part of the back cylinder D, and just before the cylinders reach the starting point on the extreme right this projecting part reaches and touches the lower arm of the lever 105, fulcrumed at 106, Fig. 137. It is therefore evident that the last slight movement of the cylinders towards the right will cause

the projecting part to force the lower arm of the lever 105 to the right, and the upper arm of the same lever to the left. Simultaneously the lower arm of lever 107, fulcrumed at 108, will be forced to the left and its upper arm to the right.

A view of this section of the mechanism on a much larger scale is seen in Fig. 145, in which the ordinary long and short punches 28 and 27, one of each, as well as one of the three peg punches 99, are shown in the headstock. In this view the cylinders are supposed to have reached their extreme positions, and the above-mentioned levers 105 and 107 have

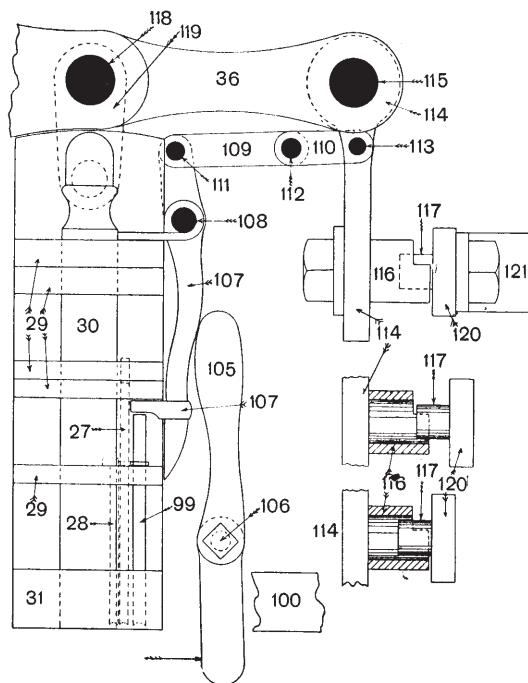

FIG. 145.

been moved from the positions indicated in Fig. 137, so that the overhanging part of the lever 107 has been forced over the top of the three peg punches 99 (only one shown) in the headstock. And at the same moment the upper arm of lever 107 will have forced the links 109 and 110 to the right. Pins 111 and 112 join the parts 107, 109, and 110. The latter, through pin 113, will have caused the pendent arm 114, which is loose upon the pin 115, to move to the right, and hence to carry the short tube 116 towards the pin 117 in such a way that the end of the latter will enter the tube

as shown. The two detached views immediately under these parts in Fig. 145 show sectional views of the tube, part of the upper portion of which is cut away, with the pin 117 in the tube in one view, and out of it in the other.

With the parts in the positions indicated in Fig. 145 it is quite evident that when the treadle 43, Fig. 137, is depressed, and the end of lever 36 caused to move downwards, the headstock will be forced down by means of the pin 118 and the link 119, Fig. 145, and at the same time the three peg punches 99 in the headstock will be forced through the paper by the projecting part of the lever 107. It is also evident that since the pin 117

is inside the tube 116, the upper part of the tube will carry the pin downwards, as well as the lever 120 to which the pin is bolted.

Referring now to Figs. 137 and 140, it will be seen that the lever 120 is fulcrumed on a long rod 121 supported by pillars 122. Two similar levers 123 are fixed to the same rod 121, and these are connected to the upright rods 124, Fig. 137, rising from the upper block 125, by means of links 126. Consequently, when the lever 120 is carried down by the action of the tube 116 on the pin 117, it is evident that the rod 121 will be partially rotated, and sufficiently far to enable the connections to impart a downward movement to the blocks 125 and 127; these move vertically on the slides 128, and thus force the remaining three sets of punches, nine punches in all, through the strengthening strips of the paper for that particular card.

We hardly need mention the fact that the parts 120 to 128 are operated once only for each card, and that immediately the foot pressure is removed from the treadle 43 the cylinders are moved by the pawl 58 and the rack 54, Fig. 141, the small projecting part on the back cylinder being withdrawn from the lower arm of lever 105, Fig. 145. When this happens a small spring causes the lower arm of lever 107 to withdraw the projecting part from the peg punch 99 in the headstock, and, of course, simultaneously to break the contact between the tube 116 and the pin 117, while a spiral spring 121¹, Fig. 139, brings rod 121 to its normal position. During the operation of punching for the remainder of the card, the tube 116, Figs. 137 and 145, can descend each time with the headstock without affecting the pin 117 and connected parts, as will be clearly seen in the right-hand detached illustration near the bottom of Fig. 145.

The first move of the cylinders to the left carries the pointer 95, Fig. 140, from the double mark on the scale to No. 0. The peg holes which have just been cut by the peg punches in the headstock will now be under the two rows of ordinary punches in the headstock; hence, with the pointer at No. 0 there must be a blank tread, after which the pointer 95 moves to No. 1 (even numbers only are marked on the scale). There are then 28 treads in regular succession representing $28 \times 16 = 448$ positions on the paper for 448 needles in the jacquard machine. Then another double line appears on the scale, and this represents another blank tread, because the middle of the second strengthening strip is then under the two rows of ordinary punches in the headstock.

The second division—*i.e.* from No. 29 to No. 56 on the scale—represents the next 448 positions or needles, and these are cut similarly to the first section. If the jacquard machine to be used contains 896 needles—that is, for a card similar in size to those in Figs. 142 and 143—the cutting is finished when the pointer 95 reaches No. 56 on the scale, Fig. 140,

and the cylinders are returned to the starting point as already described. If, however, the card is similar to that in Fig. 144, and for a 1344's jacquard, the operation is continued, starting with a final blank tread at the position indicated by the pointer 95 in Fig. 141, which shows that all parts have moved to the left for this distance. For such a card the cutting would finish at No. 84 on the scale—that is, $84 \times 16 = 1344$ needles. As the paper is moving from one end to the other it is supported by a long wide brass plate 129, Fig. 140, and the latter is in turn supported by the bridge 130.

In order that the correct travel may be imparted to the various levers from the keys 6 to the headstock, the levers are checked in their downward movement by the bar 131 bolted to the frame 35, Figs. 136 and 137. Provision is also made to limit the movement of the treadle 43 and the headstock by the collars 132, Fig. 138, on the rod 41, while a further check is introduced in the headstock as shown by the screw 133, Fig. 132.

All the cuttings from the under-block 32, Fig. 132, of the headstock fall into the funnel 134, Fig. 137, and ultimately into the box 135. A footstool 136 is usually placed as shown. Circular leather driving belts 137 are provided to help to draw forward the paper, and in general to keep it at the proper tension without undue stress.

It is sometimes desired to use fewer needles, say 12 rows instead of 16. When this is the case it is very desirable to cover up those keys which are to remain idle, and the rows to be cast out are the two outside rows on each side of the card—that is, the outer ones in each of the two zigzag rows. Thus, the following numbers in Fig. 146 represent one pair of rows, or 16, and those numbers crossed out represent the rows not in use :

ø	10	11	12	13	14	15	16
x	2	3	4	5	6	7	ø

FIG. 146.

The 1st and 16th keys are covered by sliding the plates 138, Figs. 137 and 140, over them, and then fastening the plates in position by the milled head screws 139. Another plate secured near to or on the fulcrum 61 in the same figures can be rotated until it covers the 8th and 9th keys. A larger number of keys at the ends can be covered by the plates 138 if fewer rows have to be in use.

In Fig. 129 the seven cards on the cylinders, or rather between them, are marked 243 to 249 inclusive. These are supposed to be the corresponding picks in a design, and it is quite clear that the 246th card is in a position immediately under the punches and in the course of being cut. The picks 241 to 246 are represented on the first six lines of the design in each group in Fig. 147, the pick marked with an arrow being the 246th,

which is only partially cut in Figs. 130 and 131. It will be noticed that there are 448 threads represented on the design-paper, in Fig. 147, and these represent all those in the first section of the card. It will also be

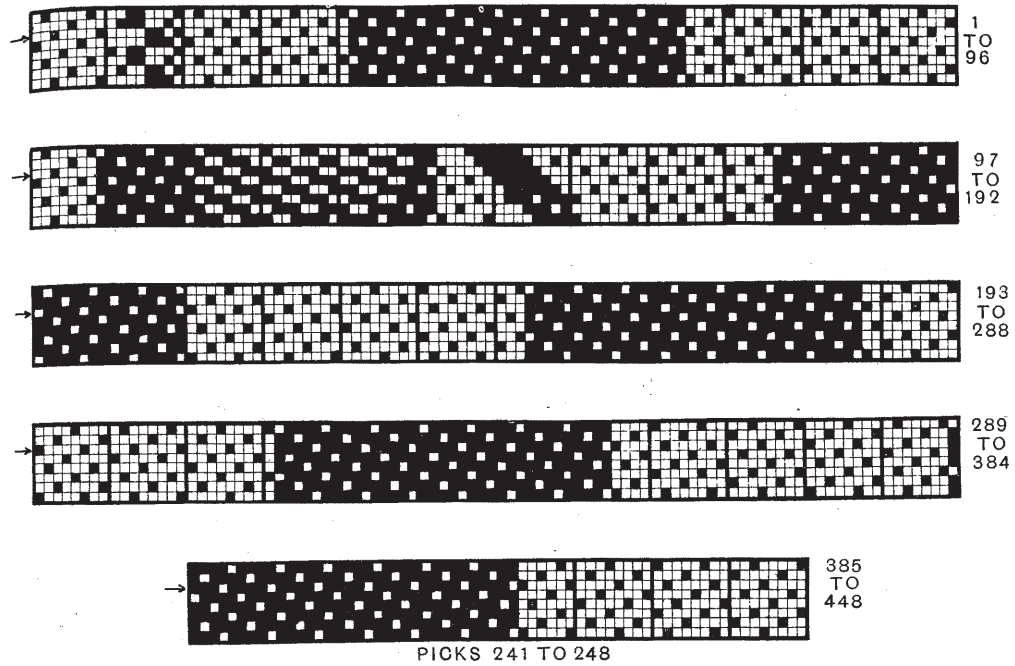

FIG. 147.

noticed that when one reads each pick from end to end, the corresponding marks on the threads will appear on the cards as below, starting at *,

	25	26	27	28	29	30	31	32
	17	18	19	20	21	22	23	24
	9	10	11	12	13	14	15	16
*	1	2	3	4	5	6	7	8

and so on, reading upwards on the card.

It has already been pointed out that neither lacing nor lace holes are required, as the total number of cards required is in one length of paper.

CHAPTER IX

READING-BOARDS ; CARD-CUTTING MACHINE FOR THE LACE TRADE

IN practically all piano and similar card-cutting machines the reading-board is supported by some convenient part of the framework of the machine, somewhat as illustrated in Figs. 67, 68, 69, 127, 128, 137, and 138. When cutting from two large sheets at the same time—say, when the design is intended for a 1200's jacquard machine of a fine or medium pitch type—it is obviously impossible to have the 150 blocks or bars of eight threads, or the 100 blocks of twelve threads, in one straight line, unless the blocks are exceedingly small. Even if the blocks were reduced to a convenient size for the purpose of having them on the same line, the designing and the reading would be conducted under very trying conditions, and hence the arrangement would be scarcely practicable. Therefore, when cutting from designs which are too wide to be read conveniently, the design-paper is in two portions, and each card is cut from the corresponding lines of the two pieces of point-paper, and consequently there are two straight edges, one in the lower part of the board and one in the upper part.

The process of cutting from two such designs is, even under the best arrangement, rather complicated and difficult, particularly if the operation sets up a pronounced vibration in the board. The usual method of supporting the reading-board is, on the whole, a suitable and convenient method, and is perhaps as good an arrangement as can be adopted when the machines have to be moved from place to place. When, however, a permanent position has been chosen and fixed for any particular machine, it would probably be an advantage to support the reading-board independently of the machine. This would not only give the card-cutter more freedom in performing the various operations, but would also eliminate the vibration which always obtains when the cutting is in progress ; at the same time the permanent steadiness of the board would enable the operative to read more easily and more quickly, and the marks on the design-paper would not affect the eyes as much as they do when vibration

is present. With an independent support for the reading-board the eyes would be less fatigued, and greater production should result. These statements refer only to those machines where the reading and punching are proceeding simultaneously, or nearly so; for the plate machines, such as that illustrated at Figs. 88, 90, and 91, the arrangement illustrated is probably the best.

In all cases, however, one straight-edge at least is required. There are different methods employed for the movement or the use of the straight-edge. That illustrated on the reading-board in the above-mentioned Figs. 68 and 69 is moved positively in both directions, each side having

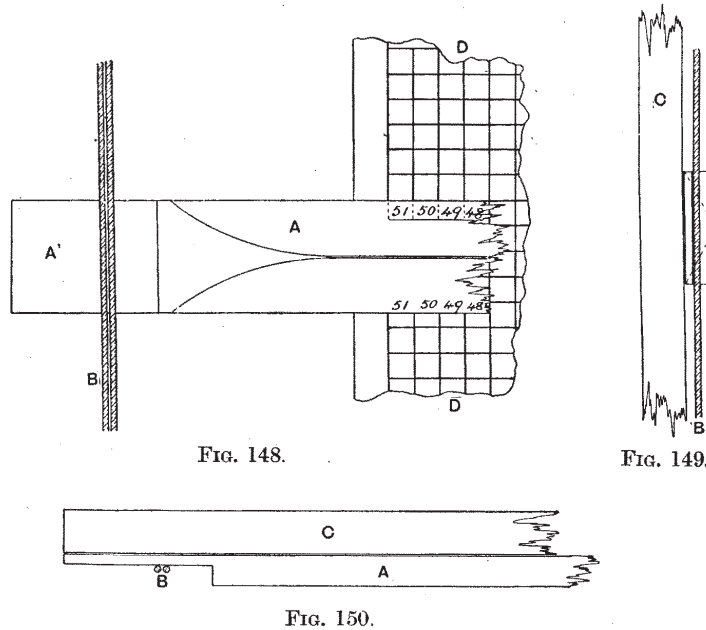

its separate adjustment. There is probably less chance of the straight-edge getting out of line with this type than with any other. The only objection to its use is the slowness of the movement when the cutter has to return it each time it reaches its limit on the board. For this reason some cutters dispense altogether with the screw adjustment, and fit up a simple and inexpensive arrangement such as that illustrated in Figs. 148 to 150, which show respectively portion of the front elevation, portion of the side elevation, and plan.

The straight-edge A is bevelled as usual, and is indicated by the dotted lines in Fig. 149. Each end A¹ is cut away as shown in Fig. 150, and two cords B are passed in front of the cut-away part; the upper ends of the

ords are passed over the top of the reading-board C, and the lower ends under the table, and then the ends are tied firmly together. The cords B thus hold the straight-edge A securely against the reading-board C, upon which the design-paper D is pinned as usual. The straight-edge can be moved easily and quickly after each line has been cut, and it is quite clear that when it is required to move it from its lowest position to its highest position it is only necessary to push it upwards—an operation which is done almost as quickly as the movement from one line to another.

Some cutters, and perhaps most of them, read from the upper edge of the straight-edge A, Fig. 148, where the last four large blocks of the design-paper are represented by the numbers 48, 49, 50, and 51; other cutters, on the other hand, read from the lines of the design-paper under the lower edge of the reading-board. The reading-board is numbered here also with the last four blocks. In the latter method the cutter can see the parts of the design which are to be cut next, but in the former case it is evident that the immediate uncut continuation of the design is under the straight-edge. When a standard size of design-paper is used, the straight-edge A is often painted white, ruled to the same pitch as the design-paper, and numbered in pencil for the guidance of the cutter.

A broad metal straight-edge is often used for a guide, and this metal edge, which is a fixture, is kept close in touch with the design-paper and the reading-board by means of two flat springs—one near each end. The card-cutter then moves the design-paper after each line has been cut, instead of moving the straight-edge. In this case the paper is not pinned to the board. The reading is thus always on the same line, and this line may be chosen at the most convenient height to suit the cutter. So long as the broad metal edge or plate grips the paper securely there is little danger of going wrong, provided also that the paper is moved carefully after each line has been cut, and the design-paper marked or checked on every cut line.

The production in regard to different pitches of cards and from different kinds of card-cutting machines for one or two particular kinds of designs has already been mentioned. It will be understood, however, that the speed of cutting is regulated not only by the skill of the operator, but also by the intricacy of the design; in other words, the speed of cutting is regulated by the speed with which the various blocks of the design can be read. It has been shown that the selection of the keys by the fingers and thumbs of both hands naturally follows the reading of the squares of the design by the eyes, and, subsequently, the feet complete the cycle of operations for each short row (or double row in some cases) on the card. Three distinct operations are thus involved in this very important process. However quickly the feet may be moved, it is obvious that the two previous

selections must be accurately made before the actual cutting takes place, and consequently the cutting speed is regulated in the first place by the quickness of reading, and in the second place by the rapidity with which the proper keys for each line can be selected. Hence it is only in connection with the simplest types of design that the reading and fingering can approach the maximum speed of tramping. This limitation probably accounts for the fact that, comparatively speaking, very few power cutting machines are in use in this country for the ordinary textile trade. A power machine, used in America, is illustrated in Fig. 119.

In the lace trade, however, the reading is by means of numbers, and for this particular class of design the power cutting machine has been used with some degree of success—indeed, it is said to be giving every satisfaction. But even in this case there will evidently be some difficulty in reading the numbers on the design, and selecting the proper keys in the headstock, with the same constancy as that which obtains in regard to the regular rising and falling of the punch box. As a matter of fact, although the machines may be driven by power, the essential relation between the punch box and the card carriage should be capable of being controlled in some way or other by the operator.

The parts necessary for the successful use of power in connection with card-cutting appear to be embodied in the power-operated card-cutting machine introduced about the year 1915 by Messrs. W. Martin & Son, Jacquard Works, Nottingham. Although this machine was invented with the sole object of being used in the lace trade, we see no reason why, with simple modifications, it should not be used for designs such as those for common-harness damasks, certain quilts, tapestries, double plains, and similar cloths, where the designs are for the most part in solid masses of colour and in unpainted and weaveless areas.

A general view of the front of the above power-cutting machine with the headstock and the reading-board appears in Fig. 151. An ordinary design appears on the reading-board, but, as already stated, the actual working design appears in numbers. In the first place, it should be mentioned that this machine and others for the lace trade differ from all ordinary card-cutting machines in that two cards are introduced side by side, and are cut simultaneously; the guides for the two cards are seen clearly at the foot of the headstock in Fig. 151 and in Fig. 153. Our remarks concerning the use of a machine similar to this for the ordinary textile trade imply, naturally, the changes which would be necessary to arrange for the cutting of only one card at a time of the desired pitch, but otherwise the present parts appear quite satisfactory, necessary, and sufficient.

The arrangements for driving the machine by power are illustrated in

Figs. 152 and 153. The short shaft A, Fig. 152, and the cone pulley B are operated as usual by the fast and loose pulleys C. A short belt, not shown, passes partially round the cone pulley B and a similar cone pulley D on the shaft E. This belt is under the control of a belt-fork, which is moved laterally by means of the left treadle F, Figs. 151 to 153, and a cord G. The cord G passes over two grooved pulleys, as shown in Figs. 151 and 153, and is then attached to the rod H, Fig. 152, and the latter in turn is fixed to the belt-fork. It will thus be seen that, although a constant

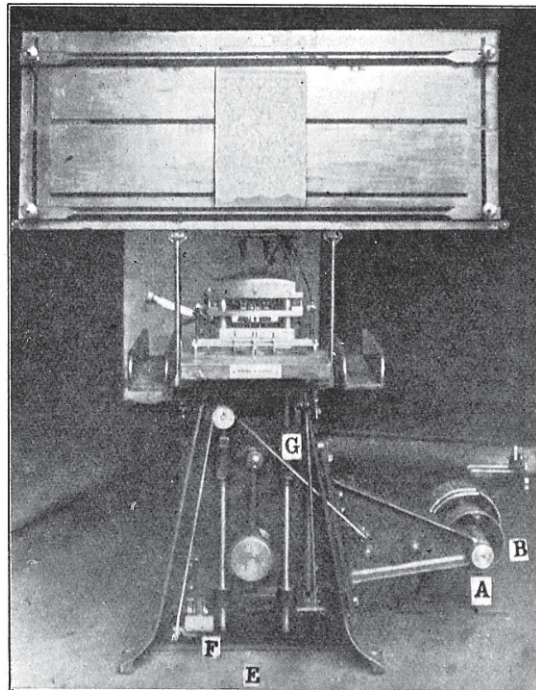

FIG. 151.

speed is imparted to the shaft A, the speed of the shaft E may be regulated by the movement of the left treadle F and the consequent movement of the belt on the cone pulleys B and D. The normal position of the belt is for the slow speed, but for very simple designs the speed may be increased by depressing the left treadle, and the mechanism can be humoured to requirements.

On the end of the shaft E, and near the front of the machine, Figs. 151 and 153, is fixed an eccentric J, which is attached as shown to the lower cross-head K. The latter is adjustably fixed by nuts L (see Fig. 154) to the two bars M, the lower ends of which are guided as shown by bracket N, while their upper ends are fixed to the upper crosshead O, Figs. 153 and 154. As the eccentric J rotates, the crosshead O receives the usual up-and-down motion. This eccentric obviously takes the place of the ordinary treadles, and it has already been pointed out that the downward movement of the left treadle in the foot-power machine causes the upper crosshead or headstock to rise, and at the same time causes the carriage and the card to move backwards one division. It is evident that even with the most skilful operative it would be a great disadvantage if the

carriage in the power-driven machine moved, without exception, one division backwards for every revolution of the eccentric. One of the chief features of the machine under notice is that, although the eccentric and the headstock move uniformly, the movement of the carriage is absolutely under the control of the operative, taking place only when and if one or more keys of the headstock are pressed in; in fact, if, for any reason, the selection of the proper keys cannot be accomplished by the time that the eccentric begins to draw down the headstock O, and if no keys happen to be pushed in, the downward movement of the headstock has no effect upon the carriage.

The bars M are attached in a suitable way to the headstock O, upon which is the usual wooden cap P, Fig. 154. This view is a longitudinal elevation of the machine and carriage, and, taken in conjunction with Figs. 155 and 156, will explain the chief parts of the mechanism. Two

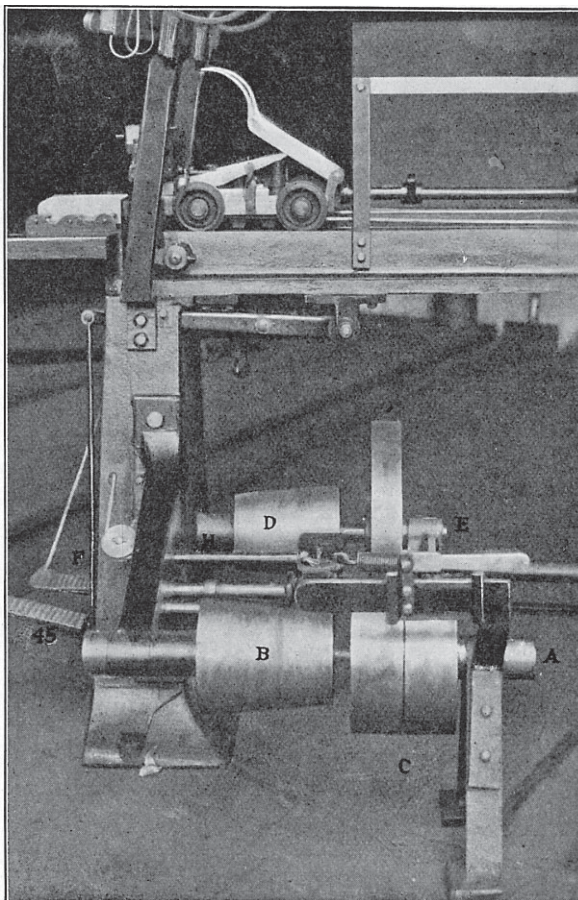

FIG. 152.

studs or pins Q, one at each end of O, pass through holes in the withdrawal plate R. The plate R can slide easily down and up on the two bars M, and its upper surface supports all the ordinary punches S and the large dummy punch or spacing punch T. Between the upper punch plate U and the withdrawal plate R are two spiral springs V which encircle the bars M, and serve to raise the withdrawal plate R to its

highest and normal position after it has been depressed by any of the punches S or T.

Secured to the withdrawal plate R are two plates W and W¹, Fig. 156, and these plates are provided with pins X and X¹. A connecting-rod Y joins the pin X to the short arm of lever Z fulcrumed at 2; while in a similar manner the connecting-rod Y¹ joins pin X¹ to a short lever Z¹, also fulcrumed at 2. The long arm of lever Z is attached at 3 to a connecting-

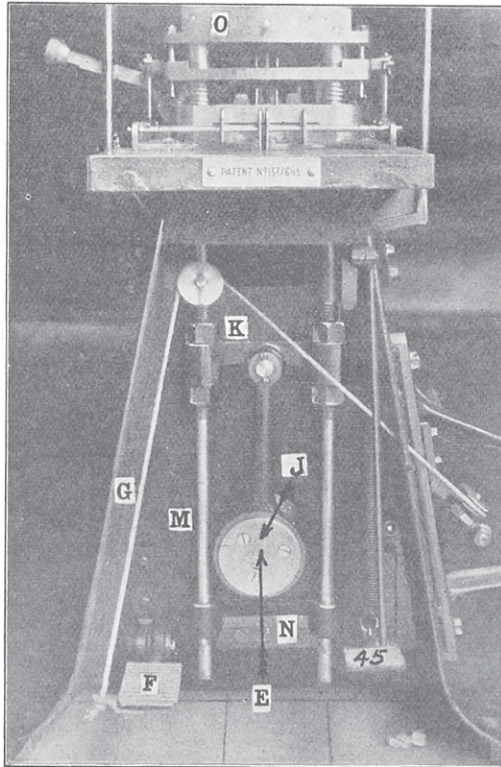

FIG. 153.

rod 4, and the latter is attached to a link 5, which in turn is jointed to the lower arm of the bell-crank lever 6 fulcrumed at 7. Finally, a connecting link 8 joins the upper arm of the bell-crank lever 6 to a short arm 9 which forms part of a rocking-shaft 10. This shaft 10 extends nearly the full length of the machine, as shown in Fig. 154, and its upper surface is provided with a web 11, as indicated in Figs. 154, 155, and 156.

The two prongs of a forked bracket 12 fulcrumed at 13, Fig. 155, drop over the web 11, and hence the bracket 12 is under the influence of the web 11. Projecting from the same stud on fulcrum 13 is a short arm 14, and the end of this arm enters a suitable slot in a

rectangular sliding plate 15, Figs. 154 and 155. This sliding plate 15 is provided with two oblique slots 16 and 16¹; two small pins 17 and 17¹ fixed to the catches or dogs 18 and 18¹ project into these oblique slots 16 and 16¹ of the sliding plate 15. The bottom ends of the catches 18 and 18¹ act upon the teeth of the rack 19, and thus control the movement of the carriage. In Fig. 154 the catch 18¹ is in contact with the teeth of the rack 19, while the catch 18 is quite clear.

The card 20 and the second card immediately alongside of it are between

the punch plates U and U¹, and are gripped in the usual manner by the rat-trap 21 on the short arm of lever 22 fulcrumed at 23; the necessary pressure to the lever 22 is imparted by the volute spring 24. The rat-trap is released in the well-known manner by the downward movement of lever 25 fulcrumed at 26. The carriage itself is supported by four wheels 27, while a similar number but smaller set of wheels 28 are attached to the pendent brackets 29; these two sets of wheels run on the upper and lower planed surfaces of the frame 30, and thus provide an easy and smooth movement for the carriage.

We might now consider the working of the machine so far as the headstock is concerned. When any of the keys 31, 32, or 33 are pushed in, their ends pass over the tops of their respective punches S, and when the headstock descends the shoulders of the punches force down the withdrawal plate R. The downward movement of the plate R naturally oscillates lever Z, Fig. 154,

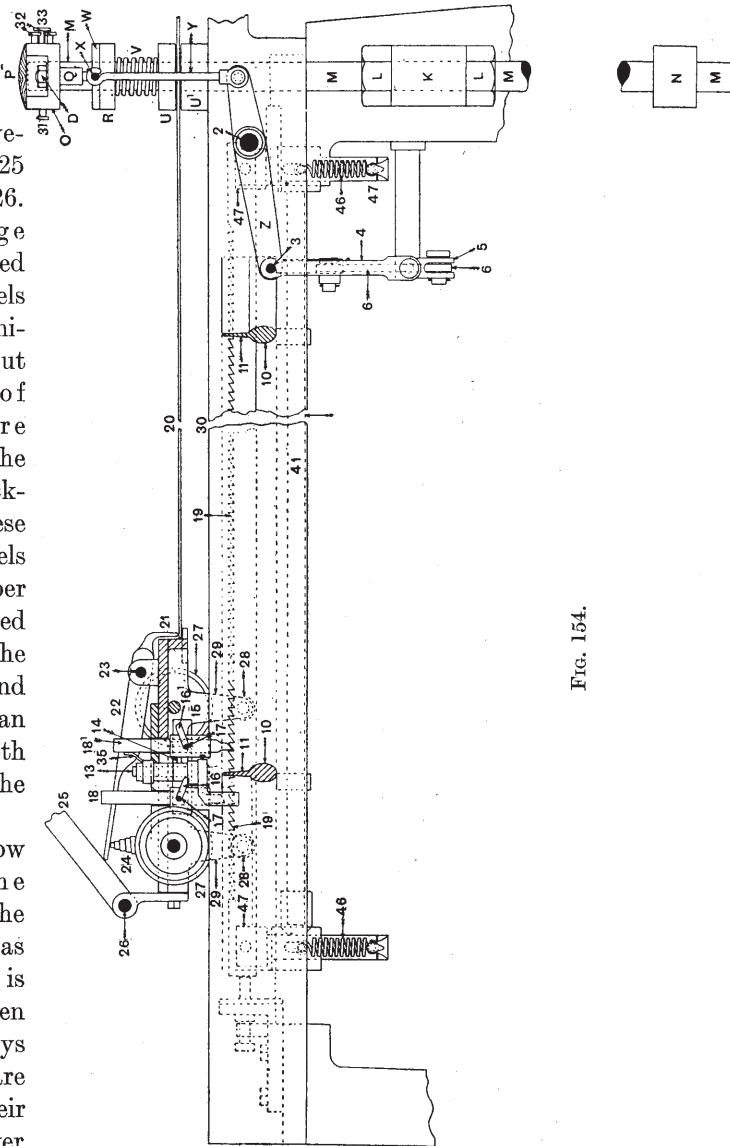

Fig. 154.

about its fulcrum 2, and the further connections from the long arm of lever Z cause the bell-crank lever 6 to rotate slightly counter-clockwise, Figs. 155 and 156, and thus impart a clockwise movement to the rod 10 and its web 11. The stud 34, Fig. 155, is introduced to enable the proper degree of backward movement to be allowed to bell-crank lever 6.

The web 11 thus moves the forked lever 12 as well as the short arm 14, and the end of the latter causes the sliding rectangular plate 15, Fig. 154, to move to the left. In doing so, it is clear that the oblique slot 16¹ will cause the pin 17¹ to withdraw the catch 18¹ from the teeth of the rack 19, but at the same time the oblique slot 16 will cause the pin 17 to force the catch 18 into contact with the teeth of rack 19. The point of the descend-

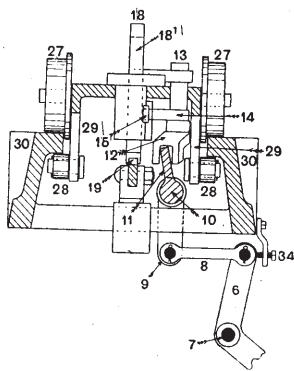

FIG. 155.

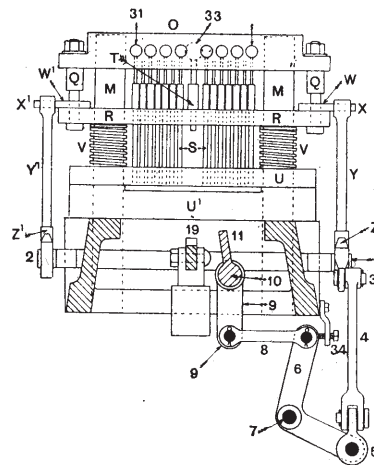

FIG. 156.

ing catch 18 reaches the tooth of the rack just before the catch 18¹ leaves the straight part of its tooth. This is necessary, for the carriage must remain stationary until the punching of that particular row is complete, and, indeed, until the punches are withdrawn from the cut portion of the card.

When the headstock O is rising, the springs V force the withdrawal plate R to its highest position, and thus bring back the web 12 and the sliding rectangular plate 15 to their normal positions—those shown in Fig. 154. While this is taking place, the catch 18 is naturally rising and the catch 18¹ falling. It is clear, however, that the catch 18¹ must not take the same tooth with which it was in contact the last time it was down. When the catch 18¹ is rising, it receives a slight clockwise movement in virtue of the pressure of the flat spring 35, and thus the lower end of the catch is moved to the left, and in descending the point of the catch comes

in contact with the sloping part of the next tooth—*i.e.* the one on the left of that with which the catch is at present in contact. The weight at the end of the cord is then free to draw the carriage backwards until the catch 18¹ assumes the vertical position, and these actions take place, one row at a time, so long as one or more punches is or are covered by their respective keys. If, however, no key is pressed in, it is evident that no movement will be imparted to the withdrawal plate R, and hence the thin parts of the studs Q, Fig. 156, of the headstock or crosshead O will simply slide down and up the holes in the withdrawal plate R. It is this unique arrangement of connections between the punches and the carriage which overcomes the practical difficulties which obtain in certain power-driven machines of the ordinary type.

In the above-mentioned lace trade, and also in connection with the particular types of fabrics which have been mentioned as being suitable for this power machine, there are several places on the design where no punching is required on the corresponding rows of the card; these similar numbers or blanks in the lace designs, or the blank masses in the other designs, may extend for several complete blocks, and since there is no alteration required in the lace design, and no weave or mark of any kind on the ground portion of ordinary designs, or of uncut, painted portions in some tapestry designs, there is no ordinary punch to be operated. A punch of some kind, however, is absolutely necessary to impart the desired movement to the withdrawal plate R and to the catches 18 and 18¹ of the carriage; hence, a dummy or spacing punch T, Fig. 156, is introduced, and this punch is operated by the large key 33 at the front of the headstock. Consequently, for all blank rows in the design-paper or their equivalents, it is only necessary to push in the key 33, and the dummy or spacing punch T then fulfils the desired function for the row-by-row movement of the carriage.

Fig. 157 is a more or less diagrammatic view of the keys and punches. The 14 ordinary punches S—two sets of 7—are operated by the 14 keys marked 31 and 32, while the two peg-hole punches 36 are operated by the two keys 37. The operative, therefore, moves the 8 keys 31 at the back of the headstock by his fingers, while his two thumbs control the remaining 8 keys at the front—4 with each thumb.

After all the rows in the card have been cut, it is necessary to break the connection between the catch 18¹ and the teeth of the rack 19, Fig. 154. This is done as follows: Fixed near the right-hand end of the rack 19 is a bracket 38, Fig. 158. The upper surface of the projection of this bracket is inclined as illustrated, and upon this inclined surface rests an antifriction roller 39. The roller 39 rotates on the pin of bracket 40, and is supported by the rod 41, while a light rod 42 is fixed to the bracket. A chain 43

passes over the pulley 44, and connects the rod 42 with the right treadle 45, Fig. 153. Hence, when the right treadle is depressed, the rod 41, Fig. 158, and bracket 40 are pulled to the right, the antifriction roller 39 acts upon the inclined surface of bracket 38, and the rack 19 is caused to descend clear of the catch 18¹, Fig. 154. The carriage may then be pulled forward to any particular row on the cards, or to the starting point near the headstock.

When the pressure on the right treadle 45 is withdrawn, the springs 46, Fig. 154, which were extended in virtue of the downward movement of the rack 19 and its supports 47, raise the rack to its normal position.

It should be mentioned that the cards which have been cut up to the present in the above machine are for use on what is known as the

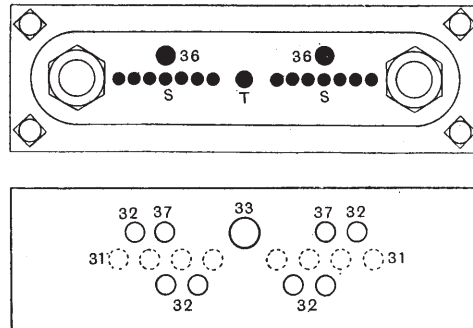

FIG. 157.

“Lever’s lace machine,” which is quite different from the machine which is used for the lace-curtain trade. The jacquard machine for the latter fabrics is situated and operated very similarly to those used for ordinary weaving, whereas the jacquard for the Lever’s lace machine is at the end of the machine. Its action is also quite different from the usual jacquard in that the holes

in the card, or rather the blanks, actuate what are known as “droppers,” and these in turn operate a series of steel thread bars. The number of thread bars in the machine varies according to the kind of lace which is being made, and one short

row on the card is required for each thread bar. For example, 120 rows on the card are required for 120 thread bars. Moreover, the holes, or rather blanks, in the card have different values according to the distance that the thread bars have to move. The thread bars naturally move according to the pattern, and their movements are in terms of “gaits.” Thus, a 10-point machine has 20 gaits per inch; an 11-point machine has 22 gaits per inch, and so on. Three of the holes in each short row of the card represent 8 gaits each, or 8 units of motion; while

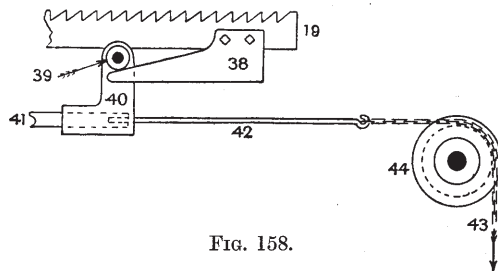

FIG. 158.

the remaining four holes in each short row represent, respectively, 4 gaits, 2 gaits, 1 gait, and $\frac{1}{2}$ gait. Consequently, each short row on the card represents, as a maximum, $31\frac{1}{2}$ gaits. If, say, droppers to the value of 23 gaits are required, the cutter presses in the keys which allow droppers to the value of 23 to be pushed into action with the thread bar. To do this, however, it is necessary to make a mental calculation, thus—

$$31\frac{1}{2} - 23 = 8\frac{1}{2} \text{ gaits to be cut ;}$$

and he therefore presses in one key for an 8 gait and one key for $\frac{1}{2}$ gait, which leaves blanks the value of which amount to 23 gaits.

The two cards which are punched at the same time differ in the cutting—one card is for the front motion of the machine, and the other card is for the back motion. Similar mental calculations have to be made for both-cards. We shall probably deal more fully with this branch when the time arrives for describing the various types of jacquard machines.

A fairly extensive range of the methods employed for the preparation of jacquard cards by various types of card-cutting machines has been illustrated and described, and it is quite evident that, even at the best, the processes of reading the marks on the design-paper, and the subsequent operations of fingering and stamping, are not only lengthy, but also, on the whole, tedious ones.

So far as the writer's knowledge goes, no really efficient mechanical arrangement has been introduced to supersede this almost universal method of reading and cutting for cards to be used on jacquard looms. With the advent of electricity for industrial purposes the attention of inventive minds was turned, *inter alia*, to that of solving the card-cutting operation electrically, and some very ingenious and praiseworthy efforts were made towards this end. Perhaps the two best-known systems were those known respectively as the Szczepanik and the Zerkowitz—both obviously of Continental origin. An exhaustive account of these systems cannot be attempted here, but it would be inadvisable, in a work of this kind, not to mention these meritorious attempts to solve a difficult problem, especially when it is quite likely that the subject will again claim consideration.

The above two systems have very little in common unless we suggest that the failure of both was due, not so much to the inability of the apparatus to cut the cards, as to the difficulty of preparing the surface from which the electrical contacts were made, and the equally important difficulty of carrying out the combined processes of selecting and cutting at a cost which was low enough to tempt manufacturers and others interested to substitute the processes for those which were established, and which still remain supreme.

Notwithstanding these serious, and at the time effective, drawbacks to the introduction of electrical apparatus, the writer is of the opinion that, with the gradually increasing facilities offered by ever-advancing additions to electrical apparatus, it is quite possible that the combined efforts of electricians, chemists, and textile experts will succeed in placing a practicable electrical card-cutting machine on the market. It was on the advice of the writer that the experiments were discontinued in connection with the Szczepanik system, and this course was not decided upon without a reasonable knowledge of the difficulties which then existed. The scheme was not sufficiently developed to enable the apparatus to compete with the existing mechanical methods; and besides, at the time, a more important branch was in a higher, though still imperfect, stage of development.

One very serious fault in connection with the introduction of revolutionary-like apparatus is that those directly connected are prone to claim advantages far in excess of the capabilities of the apparatus, even at its best. It is a much safer plan, and one more likely to inspire confidence, to attempt to capture the trade for the simpler work—the other will follow if the apparatus is capable of conducting it satisfactorily, economically, and quickly.

CHAPTER X

READING-IN FRAMES AND CARD-PUNCHING MACHINES FOR LACE, TAPESTRY, AND SIMILAR TRADES

IN connection with certain methods of card-cutting and repeating mechanism, the piano card-cutting machine is displaced by a type of "reading-in" frame which is provided with a number of vertical cords or strings equal to the number of needles in the jacquard. Then individual horizontal or cross cords are interlaced amongst the vertical cords in a manner somewhat similar to, but more simply than, that which obtained in connection with the draw-boy jacquard. Thus, Fig. 159 illustrates on a small scale the principle employed. The vertical cords A, equal in practice to the number of needles in the jacquard, are kept separate by means of the pegs or pins B, and the point-paper design placed behind the cords so that the latter may pass over and partially cover the vertical rows of small squares; if necessary, the design can be placed over the cords, and the pins B marked in some way to facilitate the selection of the cords with respect to the painted and unpainted squares of the point-paper design. In some districts the point-paper designs are still mentioned as containing a certain number of cords; this distinction is probably due to the relation between the design-paper and the vertical cords in Fig. 159.

The reader-in places a horizontal cord, say C, Fig. 159, amongst the vertical cords A, according to the marks and blanks of the point-paper design. When this cord C has been inserted, it is slid downwards on the vertical cords A, and a second cord D, for the second pick of the design, is interwoven amongst the vertical cords A. For example, the two cords C and D represent the picking out for the two detached picks immediately under the design.

The reading-in may start either at the top of the design (the last pick) or at the bottom of the design (the first pick). Such a method is employed in connection with the preparation of cards for jacquards used in the manufacture of certain kinds of lace curtains, but, as will be pointed out

shortly, the method for this particular branch of the textile industry is being replaced by more modern processes.

When all the picks of the design have been provided with a corresponding number of horizontal cords, C, D, etc., Fig. 159, the combined cords are taken to work in conjunction with apparatus somewhat similar in principle to the mechanism in Figs. 345 to 349. The sheet of cords in Fig. 159 is placed flat on a table, the upper ends of the warp cords (the original vertical cords A) secured firmly to the table or other suitable support, and the lower ends to another series of cords which are attached to the above-mentioned apparatus. Each cross-cord or pick is then

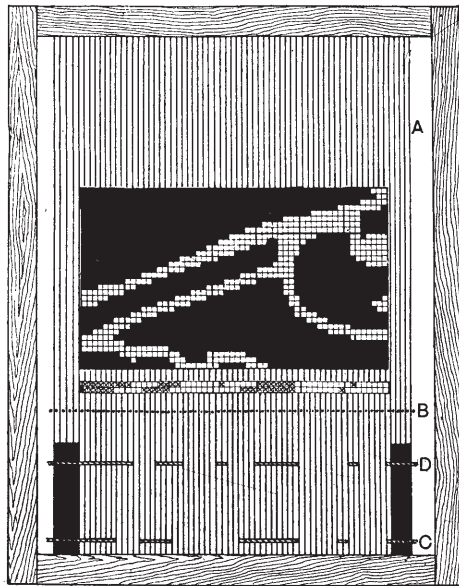

FIG. 159.

taken separately, and an iron bar inserted in the order amongst the threads; this iron bar is then pressed downwards to draw a number of cords equal to the number under the bar, with the object of preparing a plate of punches similar to those in plate 4 in Figs. 346 to 349.

This plate of punches is then taken to a powerful punching machine, usually provided with two cranks, which completes the punching of a whole card at a time, and by very similar means to those in connection with Fig. 307, or Figs. 324 to 327—that is, the card is placed between the punching plates, and then the complement of punches forced through the card

as the bottom plate is forced upwards by the two cranks.

The lashing or string system of reading-in, as demonstrated in Fig. 159, although being supplanted by more mechanical devices in the lace industry, is extensively practised on the Continent in the preparation of cards for tapestry and other designs on a large number of cords, and in which the weaves used are difficult to insert on point-paper, or difficult to memorise by a card-cutter. When the reading-in is completed, the subsequent operation of punching the cards is conducted in different ways, as demonstrated in Chapter XVIII.; the reader, however, is advised to study the remainder of this chapter, which deals with analogous systems adopted in the lace industry, before considering the application of

the reading-in frames to the elaborate mechanism displayed in Chapter XVIII.

Fig. 160 illustrates one type of mechanism for the purpose as made by Messrs. William Benson, Ltd., Robin Hood Works, Nottingham. The necessary number of vertical strings A, together with their essential cross-cords, constitute the equivalent of the prepared simple illustrated in Fig. 399, and, as already mentioned, the cords for the lace trade are arranged horizontally to facilitate the selection of punches for the card-cutting machine. These two sets of cords are represented in Fig. 160 by the stretch A. The right-hand ends of the cords A are secured to the adjustable bolt B, while the left-hand ends of the same cords are fastened to the cords C; the latter in turn are hooked to the adjustable needles D of the automatic card-punching machine on the extreme left of the figure.

Two views of the automatic punching machine are illustrated in Figs. 161 and 162, the former view representing the feed side, while the latter view represents the delivery side. A non-automatic feed machine is also made by the above firm of engineers, and the card-punching machine used for this method is illustrated on the right in Fig. 163. The selecting or reading-in machine which is used in conjunction with the non-automatic card-punching machine is shown on the left in Fig. 163.

In both cases the selection of the necessary cords C, Fig. 160, for each card to be cut is made by apparatus similar to that described. But, whereas one operative can conduct the whole of the work in conjunction with the mechanism illustrated in Figs. 160 to 162, two operatives are

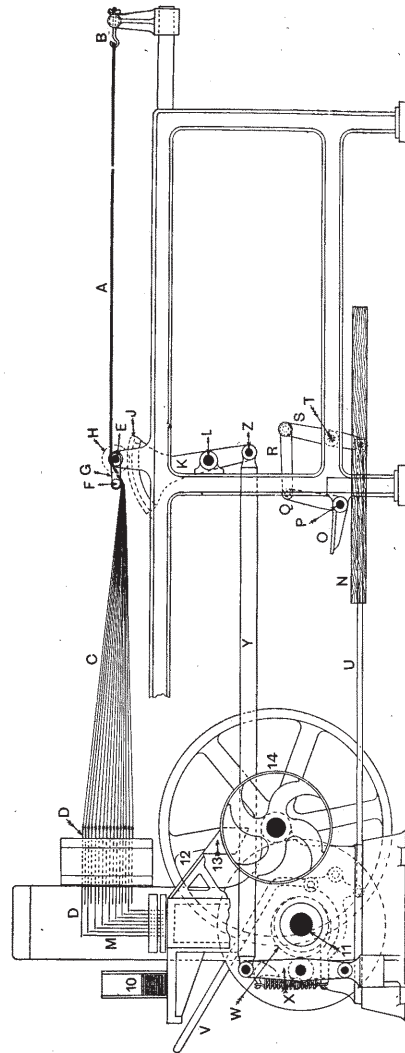

FIG. 160.

required for half the production of the same class of work with the machine illustrated in Fig. 163. The operative who attends to the latter card-punching machine removes the plate of selected punches from the machine on the left, places it in position on the feed table of the machine on the right, inserts the blank card, and the machine then punches all the required holes in the card at one stroke.

On referring to Fig. 160, it will be seen that all the original vertical cords A pass over a rod E and under a second rod F. The second rod, which is held in the movable bracket levers G (one only shown) fulcrumed

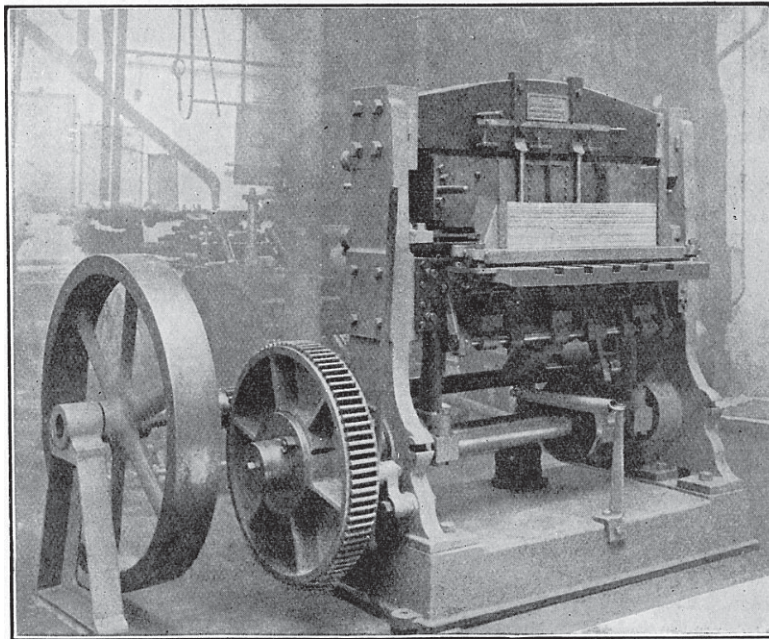

FIG. 161.

at E, is capable of being oscillated through the requisite angle by means of the pinion H and the rack J of the lever K, fulcrumed at L.

The rod F, Fig. 160, is inserted amongst the cords A according to the interlacing of the first cross-cord. Then, when the bracket levers G are moved counter-clockwise the affected cord C will clearly pull the corresponding horizontal needles D clear of the upper ends of the vertical needles M. When the selection has been made by placing the rod F amongst the cords A, the operative, who stands on the platform N, presses down the treadle O fulcrumed at P; this action operates lever Q, link R, lever S fulcrumed at T, and rod U, and this rod, through suitable con-

nections, releases a driving bolt which engages with studs, and causes the machine on the left to make one revolution, after which a cam withdraws the driving bolt. The machine may also be started by means of the handle V. It will be seen that when the machine on the left starts, a cam W, acting on an anti-friction roller X, causes the latter to impart motion to the rod Y, and hence to lever K, since rod Y is attached to the latter at Z. This operation is repeated for every cross-cord, that is, for every pick of the point-paper design. The stretch between the horizontal needles D, Fig. 160, and the rod F is much greater than is represented in the figure.

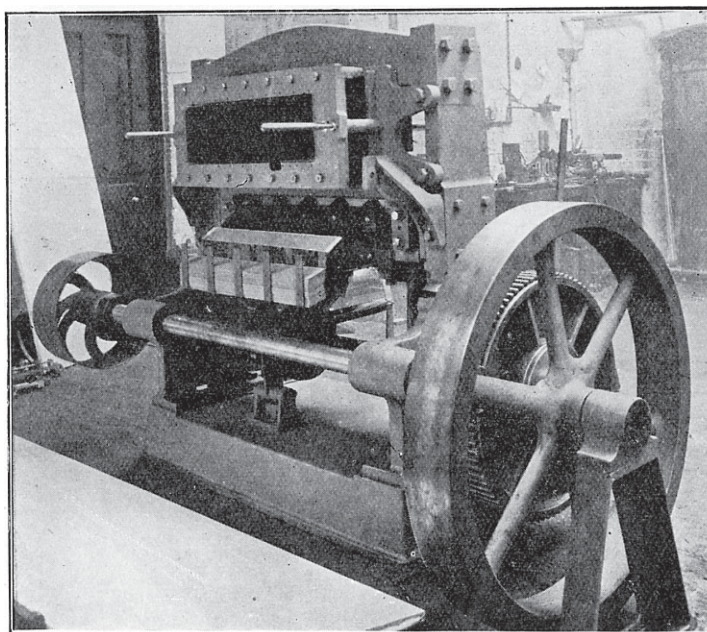

FIG. 162.

In Fig. 160, eight vertical needles M only are shown along with a corresponding number of horizontal needles D. The actual construction of these parts differs slightly from that illustrated in Fig. 160, and a better idea of the arrangement will be obtained from the enlarged view in Fig. 164, where the ends of the cords A are shown attached to the hooked ends of the horizontal needles D. These needles are staggered in order to obtain more space, and thus to admit of stronger parts. There are two rows, or 32 horizontal needles D, for each pair of rows of vertical needles M, but 16 of each set only are shown in Fig. 164. But since the next 16 horizontal needles D are midway between those shown, it follows that

the corresponding 16 vertical needles will be rather shorter than the row illustrated; each pair of rows is similar, and around each horizontal needle D is a spiral spring 2, behind which is a pin or collar, so that after

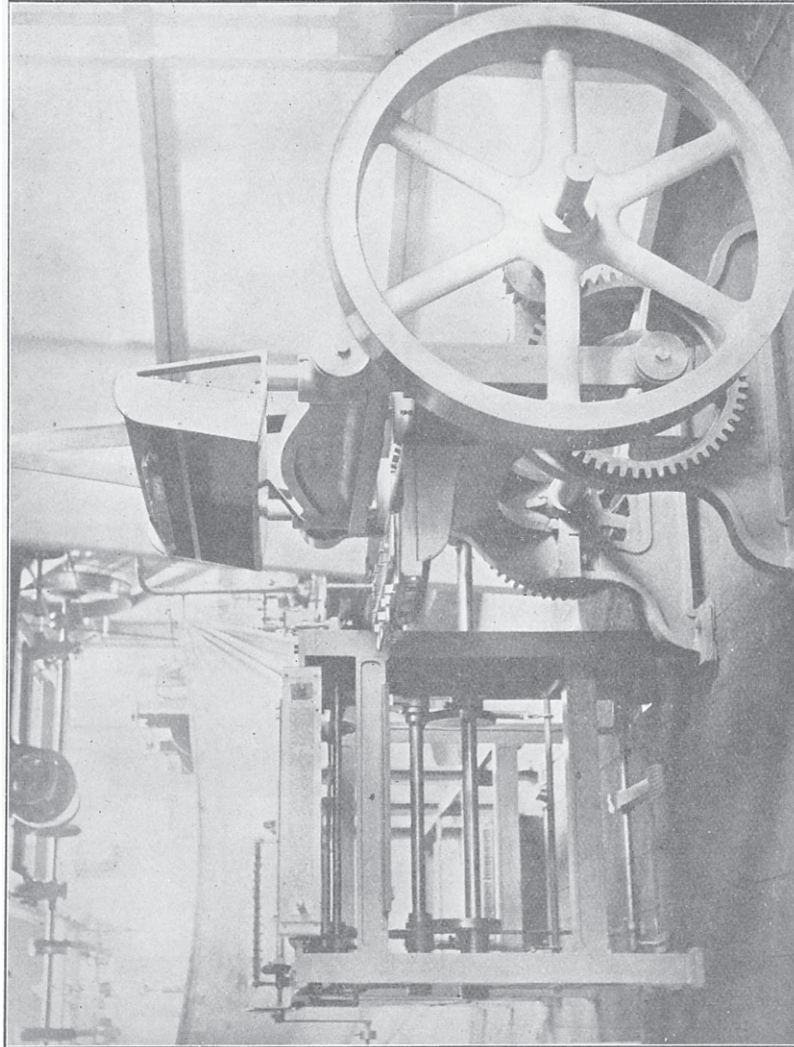

FIG. 163.

the horizontal needle has been drawn forward by a cord C, the compressed spring 2 carries it back to its normal position. Suitable guides as shown are provided for both sets of needles.

The actual punches 3 are located in the fixed block 4 and the upper movable block 5, while the card 6 to be punched occupies a position between the upper movable block 5 and the lower movable block 7. The lower block 7 is operated by the cranks shown clearly in Fig. 161, connecting rods 8, Fig. 164, and blocks 9.

As illustrated in Fig. 164, one full row of 16 horizontal needles D is shown with the free ends of the needles over the 16 vertical needles M, and the card 6 is in position between blocks 5 and 7; hence, when the block 7 is raised by the cranks, the block 5 will also be raised, as well as

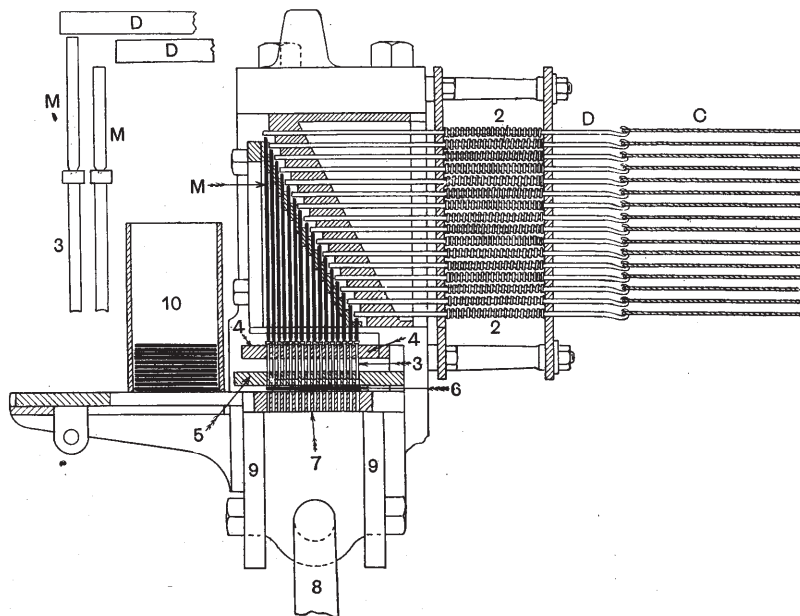

FIG. 164.

the card 6. The punches 3, however, are held stationary by the ends of the horizontal needles D, and, consequently, the lower ends of the punches 3 are forced through the card 6, and enter the holes of the lower block 7, carrying the punched-out discs of cardboard with them. If, however, all the 16 horizontal needles D had been drawn to the right by the movement of the corresponding cords C, Figs. 160 and 164, the upward movement of the blocks 7 and 5, and card 6, Fig. 164, would enable the card to carry upward the punches 3 and the vertical needles M, since under this condition there is nothing to hold the latter firmly in position.

The above description represents two extremes—a full row punched and a full row left blank—but any number of rows or partial rows, in any

order, can be punched or missed as desired. An enlarged detached view of two punches 3, two vertical needles M, and parts of two horizontal needles D, appears in the upper left-hand corner of Fig. 164. The upper needle D is in the active position, while the lower needle D has been withdrawn.

After each card has been cut in the automatic machine, the next card to be cut, the lowest one in the magazine 10, is automatically carried forward, through a slot opposite the lowest card and near the base of the magazine, by means of slides which operate in grooves in the table; these grooves are clearly shown in Fig. 161.

The card is fed in by means of a spring and suitable levers, while a cam on the shaft 11, Fig. 160, withdraws the slides. As the new blank card is being placed in position—that occupied by the card 6 in Fig. 164—it pushes out the newly punched card, and the latter slides down the incline 12, Fig. 160, and drops into the receptacle 13. In Fig. 162, a card newly punched is shown descending the slide 12 towards the other cut cards in the receptacle.

Messrs. Benson's most modern type of apparatus for the preparation of jacquard cards is illustrated in Fig. 165. The automatic card-punching machine on the left is identical with that shown in Fig. 160; the driving pulleys 14 in the latter view are omitted in Fig. 165, but the pitch circle of the small pinion 15 and that of the large wheel 16 on the main shaft 11 are shown.

The difference between the views in Figs. 160 and 165 lies in the method of selecting the horizontal needles D by means of the cords C. In Fig. 165 the cords C play the same part as harness cords in jacquards, and may be tied up to the horizontal needles similarly to harness ties in order to minimise the number of needles and hooks used in the jacquard machine on the right when repetition of pattern occurs.

The cords C are attached to the bottom bends of the hooks 17 of the jacquard; these hooks are arranged horizontally as shown, and the normal positions of their upper or right-hand bends or hooks are off the knives 19 of the griffe 20. A corresponding number of needles 18 are loosely attached to the hooks 17 in order to move the latter on or off the knives 19 of the griffe 20 as desired. The griffe can be adjusted by means of the hand-wheel 21, a pair of bevel pinions, rod 22, and a suitable screw. The lower ends of the needles 18 project through the needle-board 23.

When this apparatus is used the pattern is cut on a common straw-board card by means of a piano card-cutting machine. Then these cards may be fed by a boy on to the 12-sided cylinder 24, which is connected by link 25, bell-crank lever 26, and other rods and levers so as to be operated from a cam on the main shaft 11 of the automatic punching

machine. A somewhat similar arrangement of cam, levers, and rods enables the lever 27 to operate the griffe 20. The machine can be placed in and out of action by the treadle 28, lever 29, and rod 30.

Instead of placing the cards singly on the 12-sided cylinder 24, they may be joined together as at 31, or made into a similar chain by means of gummed tapes, in which case a 4-sided cylinder 32 replaces the 12-sided cylinder 24. When the cards are fed singly on to the latter cylinder, the speed is 20 cards per minute, but when formed into a chain they may be operated at 35 cards per minute by the 4-sided cylinder 32.

Some cards have 14 holes per row, others have 16 per row as indicated. The end of one of the latter is shown detached immediately above the punch press in Fig. 165. Various lengths of cards are used, sometimes 135 rows of 16, or more, or 2160 capacity, with two, three, or four lines of lacing according to the length of the card.

An excellent arrangement is that which embodies the patent reading-in machine by Mr. Archibald Frame, Jacquard Card Puncher, Darvel, Ayrshire, and the above-mentioned automatic punching machine, both of which are made by Messrs. William Benson, Ltd., Engineers, Nottingham. The patent reading-in machine is illustrated in Figs.

166 and 167; the former is a front view, while the latter view shows the two machines coupled up ready for work.

The cords A from the machine illustrated in Fig. 160 are attached to the long left-hand bends of a series of horizontal hooks of a jacquard;

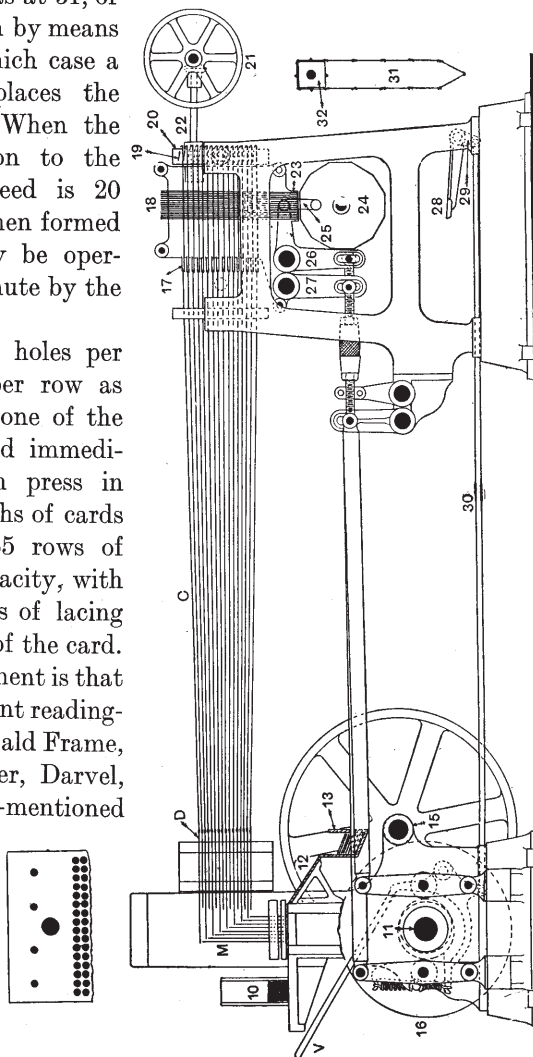

FIG. 165.

these hooks are shown behind the headstock of the modified piano machine in Fig. 166 ; the positions of several rows are illustrated, but only the first hook in each row is visible. The cords which bridge the gap between

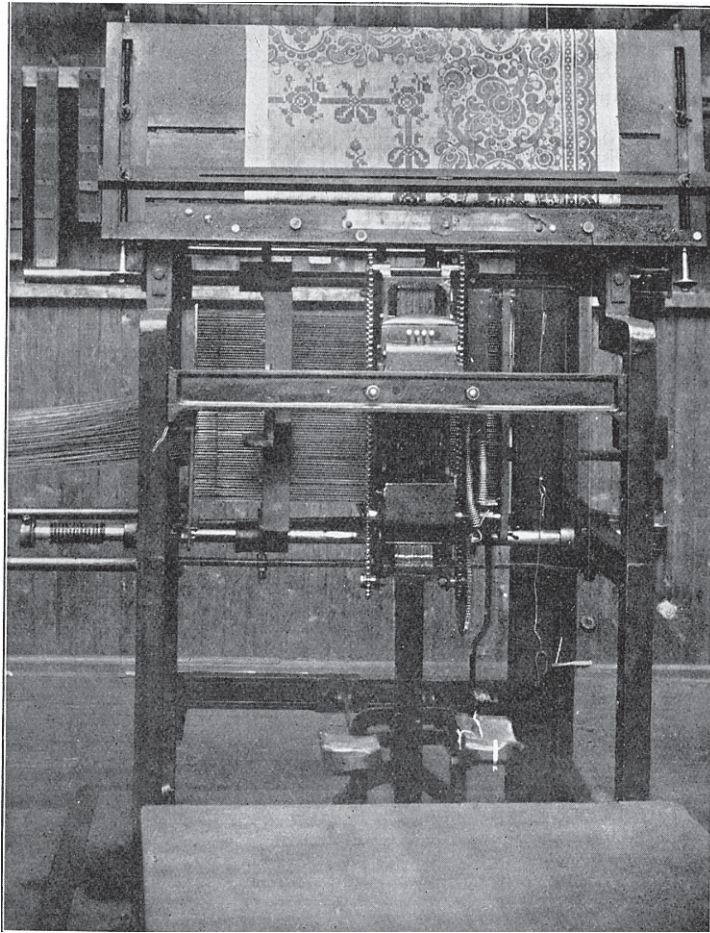

FIG. 166.

the above-mentioned hooks and the horizontal needles of the automatic punching machine are shown clearly in Fig. 167.

The headstock of the machine may have any convenient number of keys, and in the machine illustrated there are 12, of which 4 are at the front and 8 at the back. These keys are operated while reading the design, one short row at a time. Behind the headstock are 12 vertical

rods, each rod being provided with two flat springs behind and with a hinged horizontal arm in front. The horizontal arms are controlled by three-armed punchers or plungers, one arm of which carries the fulcrum,

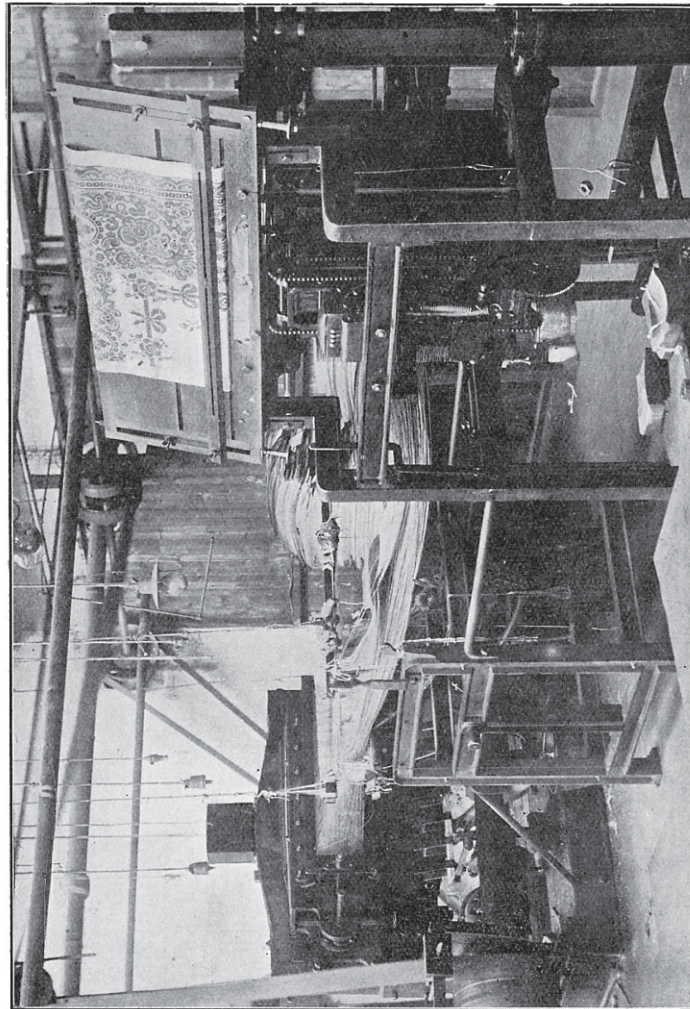

FIG. 167

another is capable of being acted upon directly by the key finger of the headstock, while the third determines whether the hinged horizontal arm shall be clear, or in the path, of a sliding part attached to, or rather moved by, the upper end of a bell-crank lever, the lower arm of which is connected by a rod to the foot-treadle. All hinged horizontal arms which are not depressed (*i.e.* arms corresponding to piano keys not pressed in) are pushed forward by the sliding part, and hence the corresponding vertical rods

are pushed forward in their slides, and returned to their normal positions by their flat springs. The 12 vertical rods act directly on a corresponding number of needles in an intermediate box, and these needles in turn act upon 12 needles (one short row) of a special jacquard, and move their hooks accordingly. These are the hooks shown in Fig. 166, to which the cords are attached.

The intermediate box of 12 needles is attached to two vertical spindles fixed to two light sprocket chains, and the latter are carried by sprocket wheels; the box is adapted to be moved upwards or downwards as desired by the foot-treadle and connections. Each short row of needles in the special jacquard can therefore have its necessary needles pushed in by the needles of the intermediate box, because the latter moves through the distance between each pair of short rows of needles of the special jacquard. These needles, and the hooks to which they are connected, remain where they have been placed by the needles of the intermediate box until the operative is ready to release them.

In this way the painted and unpainted small squares between each pair of heavily marked lines on the design-paper are recorded, as it were, on the needles and hooks of the special jacquard through the action of the above-mentioned key fingers, three-armed plungers, slide, vertical rods and the needles of the intermediate box. Some of the hooks have their short bends (those on the right) placed over the knives of a griffe, while other hooks are clear of the knives.

When the pick line of the design is completed, the operative touches the connection to the clutch mechanism of the automatic punching machine, when a complete card is cut, after which the card is ejected by the next card taken from the card magazine by the automatic feed mechanism.

CHAPTER XI

LACING AND WIRING CARDS BY HAND

AFTER all the cards for any particular design have been cut and numbered, it is necessary to join them together in such a way that they may be presented in successive order between the faces of the cylinder and the ends of the needles of the jacquard, and so enable the latter, in combination with the hooks, harness, etc., to reproduce the design on the cloth by the correct interweaving of the threads and picks.

The lacing of the cards in the form of an endless chain is absolutely essential, but the operation is often considered as being of secondary importance. This is a mistake, for imperfect lacing may result in imperfect lifts, and in a high percentage of wear and tear in the cards themselves. Carefulness and accuracy are just as essential in this branch as in any of the other branches concerned with the preparation of jacquard cards.

The correct degree of tension should be imparted to all the lacing twines, and at all sections, so that the cards will neither hang loosely over the pegs of the cylinder, nor yet have a tendency to draw each other up above the points of the pegs. Tightly laced cards are more troublesome than comparatively slackly laced ones; efforts, therefore, should be made to lace the cards so that they will drop easily on to the pegs of the cylinder, and not ride on the upper surfaces of the pegs. With constant work the lacing twine stretches slightly, as a rule, particularly if it is made of cotton; but the cards in a loose form fall more easily over the pegs on to the cylinder than do those which are laced too tightly. Sometimes the faces of one or more cylinders are rather deeper than others of the same denomination of machine, and this defect will clearly hinder satisfactory work. In order to counteract this defect, it is a good plan to have each face of the cylinder grooved where the three or more rows of lacing come, so that the cards may fit quite close to the cylinder.

There are two distinct ways of lacing jacquard cards—viz., by hand and by machine. Each method has its advocates, and there are advantages and disadvantages connected with both. It is natural to conclude that

the process of hand-lacing is very much slower than any of the mechanical processes. Although the hand-lacing is such a comparatively slow process, and necessitates a maximum number of knots on the twine, the process on the whole results in a very satisfactory set of cards, particularly if all

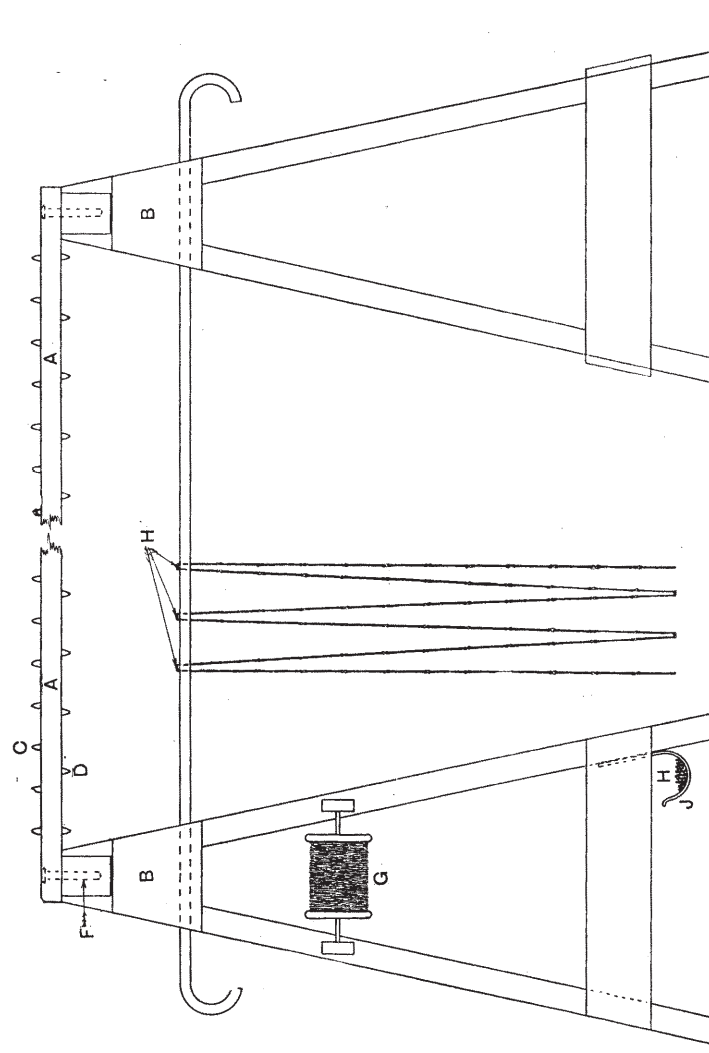

FIG. 168.

the lacing is done by the same person. It is, however, more costly than the machine lacing, but nevertheless it is largely practised by those firms who have not sufficient work to keep a machine employed continuously, and by many who have a considerable amount of lacing to do.

The cards are laced on what is almost invariably termed a "lacing frame." Several forms of these are in use, but the general requirements are such that there is very little difference between the frames themselves, and not much difference between the methods employed for supporting them. Figs. 168 to 170 are illustrative of the simple apparatus which is often used for this branch of the work. Fig. 168 is a front elevation, Fig. 169 is an end elevation, while Figs. 170 and 171 are plans of two different kinds of lacing frames on similar supports.

The frame A is often made rectangular in form, as shown in Figs. 170 and 171. Two long pieces of well-seasoned wood—say from 8 ft. to 10 ft. long, 3 in. to 3½ in. wide, and 1½ in. to 1¾ in. thick—are joined together by end pieces; the distance between the outer edges of the two long boards is slightly less than the length of the cards which are to be laced on the frame. Sometimes the end pieces are omitted, and the two separate long lengths of wood are placed the proper distance

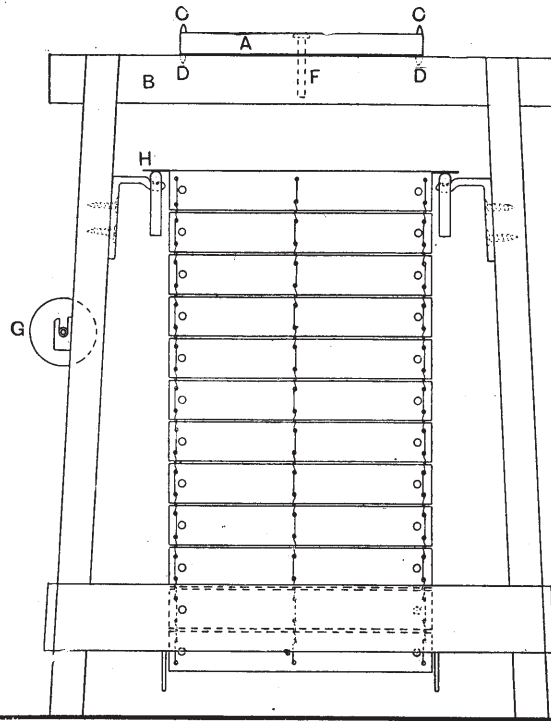

FIG. 169.

apart on the trestles B; this arrangement is often used when there are different lengths of cards to be laced, in order to obviate a multiplicity of frames. Since it is desirable—and, indeed, essential—that each card should be equidistant from its neighbours, it follows that some accurate method must be employed to preserve this constant distance between successive cards. There are two general ways of doing this:

1st. By inserting boxwood or other hard pegs C and D, Figs. 168 and 169, quite close to the outer edges of the two long wooden boards of the frame.

2nd. By inserting broad wire staples E, Fig. 171, equidistant along the two boards of the frame.

The frame as a whole, or the two detached boards if in this form, may be kept stationary by drilling a hole into each end of the frame or boards A, and a corresponding hole into the upper part of each trestle B. Then, by countersinking the hole in the frame A, a loose bolt F may be passed through the frame and into the trestle, so that the head of the bolt is flush with the upper surface of the frame, and hence will offer no obstruction to the free movement of the various lengths of cards when they are being removed from the frame, or when damaged sets are being drawn on to the frame to be repaired.

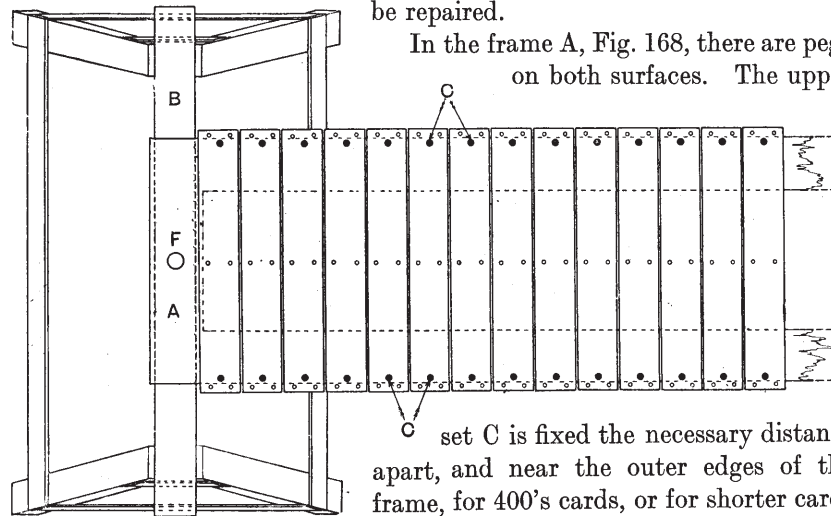

FIG. 170.

In the frame A, Fig. 168, there are pegs on both surfaces. The upper

set C is fixed the necessary distance apart, and near the outer edges of the frame, for 400's cards, or for shorter cards belonging to 8-row ordinary pitch jacquard machines. The lower set of pegs D is

fixed in a similar way, but sufficiently far apart to accommodate 12-row cards such as are used on most 600's and 900's machines. In Fig. 170 there are 14 cards of the 400's type on the pegs C, while in Fig. 171 there are 2 cards of the 600's type between the broad wire staples. It will be understood that in a similar board to that in Fig. 171, but intended for 400's cards, the wire staples E would be the same distance apart as the pegs C in Fig. 168. In the two views in Figs. 170 and 171 the cards are uncut except with regard to the peg holes for the jacquard cylinder, and the three sets of holes—two in each set—on each card for the three distinct rows of lacing. It will be observed that the two rows of pegs C on the same surface of the frame A are the same distance apart as the two pegs on each face of the jacquard cylinder; hence, if there is any mistake in the position of the peg-

hole on the card, or if the peg-hole should by any chance be omitted, the defect will be quickly recognised when an attempt is made to place the card on the pegs. On the other hand, no such provision is made in the frame which is illustrated in Fig. 171. It is seldom, however, that such mistakes occur even with comparatively inexperienced card-cutters. The chief advantage of the frame with the wire staples is that the cards are quickly placed between the wires before they are laced, and as quickly taken off the frame when the lacing is completed. Both methods are in general use, but the peg frame illustrated in Figs. 168 to 170 is obviously better adapted for keeping the cards in their correct position than is the wire frame in Fig. 171.

A complete hand-lacing frame of American design and manufacture is illustrated in Fig. 172. It embodies,

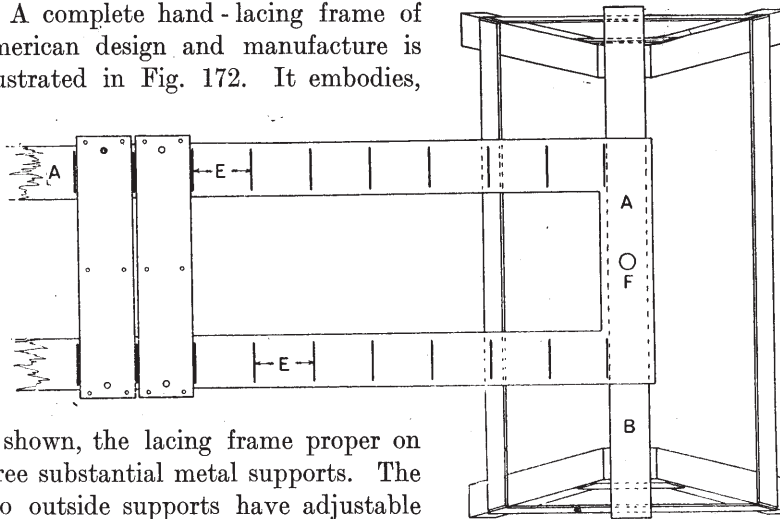

FIG. 171.

as shown, the lacing frame proper on three substantial metal supports. The two outside supports have adjustable stands for the lacing twine, while the middle support is provided with a double receptacle for the cards which are to be laced.

There are two distinct methods of placing the cards on the card frame :

1st. With the numbers of the cards facing the observer, and with the first card on the left as illustrated by the four bits of cards marked 1, 2, 3, and 4 in Fig. 173. The operator may naturally start from either side of the frame to set the cards, but if the number on the card is farthest removed from her or him, and the correct way up as illustrated in Fig. 173, the cards are placed for what is technically termed "forward lacing."

2nd. The cards may be placed with card No. 1 on the right hand and the remainder reading towards the left; they are then placed for what is technically termed "backward lacing."

The order in which the cards must be placed on the frames shall receive attention shortly; meanwhile we might assume that they are to be laced

forwards, and as illustrated by the four portions of cards in Fig. 173. First of all, it will be observed that there are two rows only of small holes shown on each card below the large peg-hole. The bottom row in each card is cut for the $\frac{2}{2}$ twill for the second row of the jacquard—*i.e.* needles 9 to 16. The upper row of holes on each card is opposite the 6th, 7th, and 8th positions of the first row of the jacquard. The three holes in this first row on each card form a convenient method of dispensing with the necessity

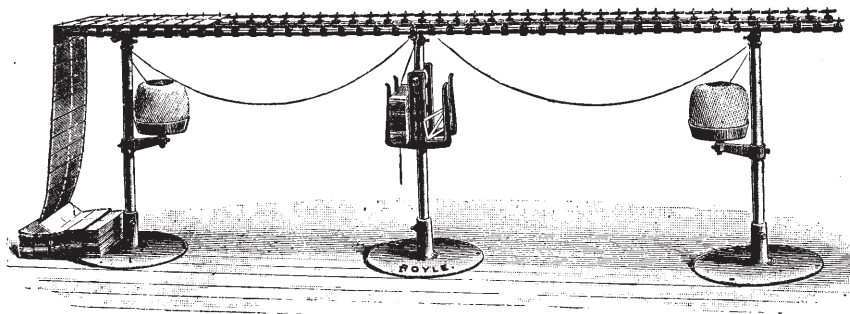

FIG. 172.

for cutting the selvage weave on all the cards for those machines where the selvages must be operated by the card itself. It will be understood that in some machines the selvages are operated direct by the cylinder and special needles and independent of the cards; the needles for this work are never covered by the end of the card, but are nearer the end of the cylinder, and controlled by empty holes or plugged holes according as the needles have to remain undisturbed or be pushed back. The above method of cutting holes on every card opposite those needles which control the

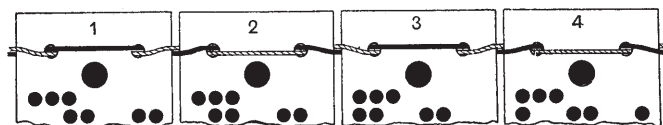

FIG. 173.

selvage threads, and other narrow tapes similar to selvages, is practically equivalent to the independent control of selvage threads; it differs from it only in that no cutting is required for the independent method, while every card must be cut opposite all needles employed for these simple weaves. The holes in the four faces of the cylinder must naturally be arranged to suit the weave required by plugging up the necessary holes—or, what is equivalent, inserting a tack at each of these places. Thus, suppose one single thread at each side of the cloth were required to weave plain merely as a catch-thread, while the adjoining threads—say 12 threads

in the warp at each side—were required to weave in the $\frac{2}{2}$ basket or hop-sack weave. The 8th needle might control the plain threads, both the same weave, while the 6th and 7th needles might weave respectively $\frac{2}{2}$ and $\frac{2}{2}$, two threads being drawn through each mail or arranged separately, if essential, and each hook controlling twelve threads—six at each side of the cloth. In many jacquard machines there are two rows of spare needles—one at each end—and when this happens the above selvage arrangements might, if desired, be attached to the hooks at both ends of the machine, and thus eliminate crossed harness cords. Four needles would clearly be required if two different threads of the plain weave were required in addition to the basket weave. In this case four holes instead of three would be cut on each card, and the cylinder arranged to suit. This arrangement of cutting all holes opposite the needles for the selvage threads clearly simplifies the cutting, prevents mistakes, increases production in card-cutting, and offers facilities for changing the order of lifting the selvage threads. Suppose, for example, that six needles were utilised for this purpose, two for the plain weave, or for some other convenient order on not more than four picks to the round if two or more colours of weft were used, and the remaining four needles for the narrow tapes adjoining the selvages. Six holes would be cut on every card opposite needles 3 to 8 in the first row; then any simple weave on four threads and four picks could be introduced into the tape portion of the selvage without altering the cards: simply withdraw the tacks and insert them according to the change of weave desired or necessary in that portion which is under the influence of the movements of needles 3 to 8 in the first row of the jacquard.

In each line of lacing, only one line of which is shown in Fig. 173, there are two separate twines, and in order that the method of lacing may be made as clear as possible, these two lines are shown in distinctive markings. The two twines serve two objects: first and foremost, that of joining up the cards into a continuous length; and, second, that of preventing end-long movement as much as possible. For preventing this displacement, or, rather, to minimise it, and to keep the cards in their proper positions, it is an invariable custom to cross the two twines one or more times for each card. In the illustration the twines are crossed only between the cards, and if this is sufficient for any particular set, the lacing is done in perhaps less time than if a different method of crossing were employed.

The operation of lacing shall now be considered in conjunction with Figs. 174 and 175. A suitable length of twine—flax cord, cotton tubing, or other material—is cut off, threaded through the eye of a blunt-ended needle, and then laced into all the holes and between each pair of cards, as is clearly illustrated in Fig. 174. This figure shows six cards for a 600's

jacquard machine, and a single twine is shown in each of the three rows of lacing holes. In practice, however, after one of these twines has been inserted in the manner illustrated, it is usual to lace the companion twine before anything is done with the two remaining rows of holes. The marking for this particular lacing twine is in imitation of twisted threads, while its companion is in solid black; see Fig. 175.

Another length of twine is then cut off and laced through the same holes, and between the cards, but in exactly the opposite way; in other words, the order of interlacing of the two twines is similar to the interweaving of two cutting threads. Although the direction of inserting the second lacing twine is always opposite to the direction of inserting the first lacing

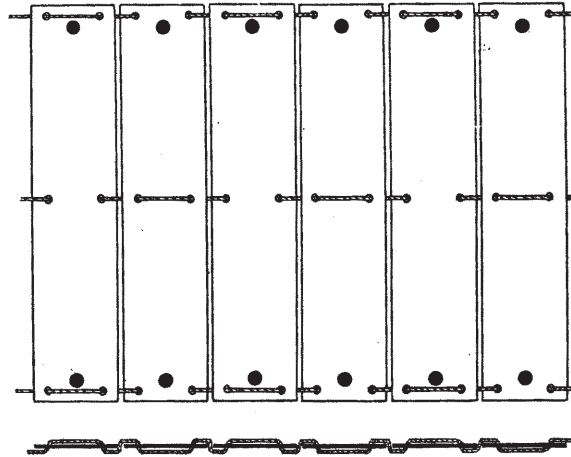

FIG. 174.

twine, the relative position of the former with respect to the latter may vary, as is exemplified in Fig. 175, where three distinct types of lacing are illustrated—two sets, A and B, laced forwards; and one set, C, laced backwards.

In A the solid black twine, or second lacing twine, is crossed from one side of the light twine to the other side every stitch—*i.e.* three times for every card.

In B and C the solid black twine is crossed from one side of the light twine to the other side twice only for each card, the manner of the crossing being plainly shown.

The method of lacing shown at A is certainly better than either of those shown at B or C, since it is calculated to hold the cards more securely in their positions. Not only so, this method of lacing prevents to some

extent the cards from slipping on the laces when the latter break at the loom. If the cards slip or slide on the laces, it is quite evident that the repairs cannot be made at the loom with the same security for future working as obtains when the cards near the broken twines do not slip.

The methods of lacing illustrated at B and C are performed rather more quickly than that shown at A. Methods B and C take the same time if we assume that the black thread is introduced first in B, and the light thread first in C. In the latter figure it will be seen that the light thread occupies the outside position on all the cards, and that the second lacing

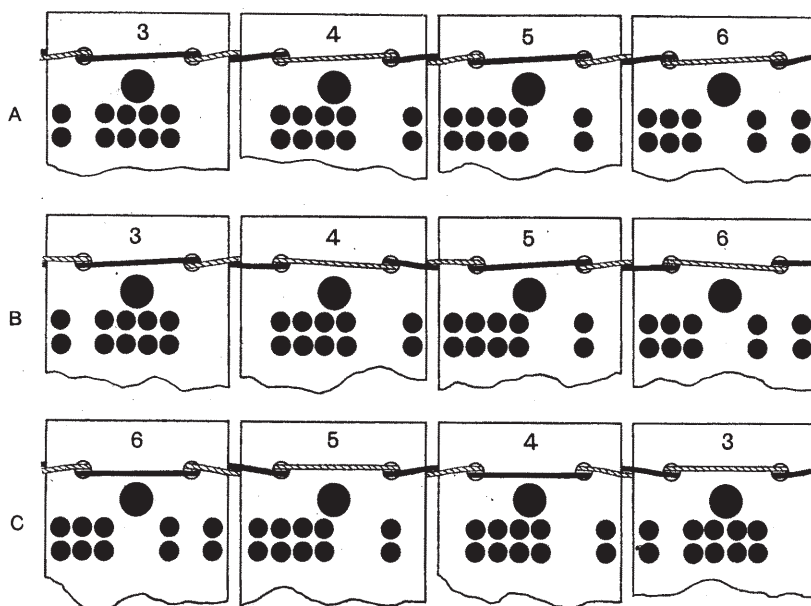

FIG. 175.

twine, the solid black one, occupies the outside position in the opening between each pair of cards; hence, no threading is necessary between the cards—the twine is simply drawn into position between them, and laced on the cards. It is obvious that the lacing at B can be performed similarly, but the twine must be crossed on the card. In A the second lacing twine must be laced between alternate pairs of cards. It need hardly be stated that these remarks refer to the two outside rows of lacing, for in all cases the twines of the middle row, or any intermediate rows, must be laced in every place. Although it is usual to lace each twine separately as indicated, some operatives become so skilful that they can use two needles at the same time, and thus proceed simultaneously with both lacing twines of one row.

All knots made by joining a new length of twine to the end of the finished length should be made on the top of the card, and preferably between the holes on the card; this is the most natural position to tie the ends together, and since no knots are under the card, the latter will be able to lie quite closely to the cylinder when it is in action, particularly if the faces of the cylinder are grooved as previously indicated. The lacing twine may be cut into suitable lengths and suspended ready for use, or it may be used from balls or from a bobbin, as illustrated at G, Figs. 168 and 169 and in Fig. 172. The man on the right in Fig. 127 appears to be wiring a set of cards. These cards, which have been cut, show the three lines of lacing quite distinctly.

Wiring.—Except for very short lengths of cards, it is essential to attach wires to the cards, at suitable distances apart, in order that the ends of the wires may rest upon the rails of the card cradle or support, and thus allow the cards to hang in groups, and also to occupy a minimum amount of room horizontally. The number of cards between each pair of wires depends, first, upon the depth of the card, and, second, upon the height of the jacquard and card cradle from the floor.

In Figs. 168 and 169 the cards are hanging twelve deep—that is, there is a wire H every twenty-four cards. The wires are tied after cards numbered 12, 36, 60, 84, etc., or every odd multiple of 12, and similarly with any other number. Thus, if the number of cards between each pair of wires is $2n$, the wires would be tied after card numbers $n, 3n, 5n \dots (2m+1)n$. The wires may be kept in any convenient and handy place; in Fig. 168 they are shown in a suitable holder J fixed to one of the trestles.

For $16\frac{1}{4}$ -in. cards the wires H are about 19 in. long, and although most of them are perfectly straight, they are sometimes made with a cranked part as illustrated in Fig. 176, or else with a similar crank in the middle of the wire. The crank illustrated coincides with the outside row of lacing which is laced first, and this provision clearly enables the wires to be tied so that their ends overhang the same distance, and thus secures uniformity. It also enables all the wires to rest on the sides of the card cradles satisfactorily, and to minimise defective working.

Fig. 176 also illustrates one method of attaching these wires to the cards. Each wire is placed on the top of the lacing between the proper cards while the latter are on the lacing frame. In the illustration the two cards marked A and B are much farther apart than they are in practice, in order that the tying may be more satisfactorily demonstrated. Each wire is tied at three places where there are three rows of lacing, and in general at every row of lacing. The wiring twine, although shown thick in the illustrations, should be thin but tough, and preferably waxed or lightly

tarred, and it should cross the wire and lacing so that the whole will be secure.

At C, Fig. 176, the wire H is shown on the top of the lacing, and the numbers 1, 2, 3, and 4 indicate the successive places into which the needle and cord are drawn. Thus, the needle first passes down at No. 1, then up at No. 2, across the top of the wire, and down at No. 3, and finally up at No. 4. The cord will then be as shown at D. The two ends of the cord are now tied twice on the top, one tie only being shown, at E. If the cards be turned over, the appearance of the under side of the cord will be as represented at F, and it will be seen that the cord does not cross the wire at this side. Nevertheless, the arrangement results in a satisfactory tie.

Another method of tying the wires is illustrated in Fig. 177. At C the

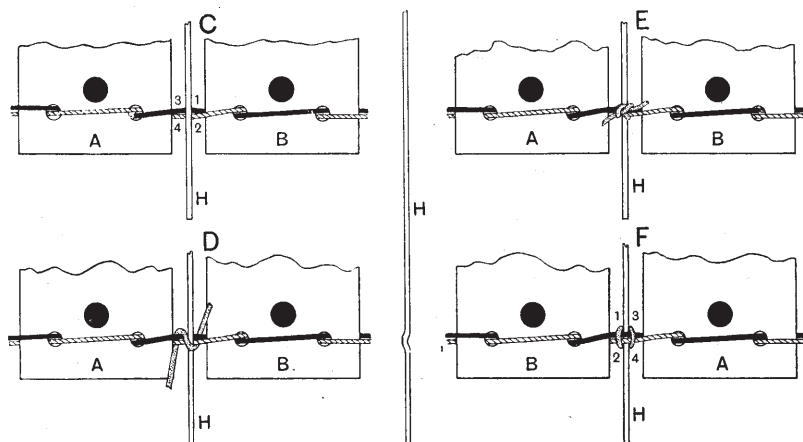

FIG. 176.

first position is shown with numbers to indicate the successive stages of the process. At D the cord, with the needle at the end N, shows that it first passed upwards through No. 1; it is then passed over the wire, down at No. 2, and up again at No. 3, as illustrated at E. The cord then crosses the wire again as shown at F, under the wire alone as depicted at G, after which the two ends, which are clearly at present under the wire, are tied securely at the top of the wire; the knots are not shown. The reverse side of the two cards A and B is shown at H, from which it will be seen that the wiring cord crosses the wire twice. The cord is thus crossed twice both above and below the wire.

As each length of laced and wired cards is finished, it is lifted off the pegs of the frame and deposited neatly in bundle form, the length of the bundle being determined by the positions of the wires. Thus if there are 20 cards between the wires, the bundle will be 10 cards in length.

Occasionally a roller is fixed on the end of each trestle, near the ends of the frame, to facilitate the transfer of cards to or from the frame. In Figs. 168 and 169 the laced and wired cards are suspended on two iron pipes under the frame; this arrangement minimises floor space, but the projecting wires, unless covered, are apt to catch the lacing twine as the operation proceeds.

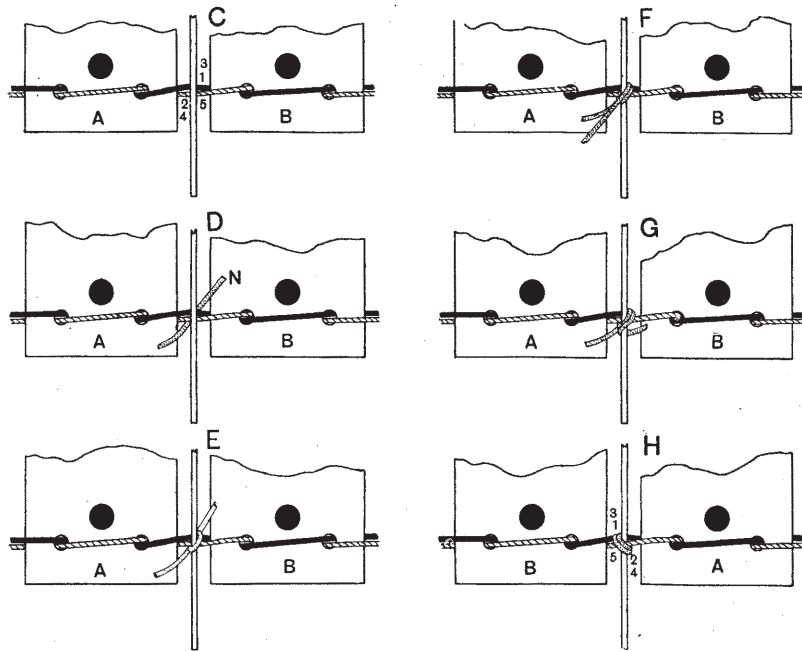

FIG. 177.

It will be gathered from the remarks which have been made, and from a general consideration of the jacquard machine, that the numbered end of the card faces the points of the needles when it is in action, and that the numbered end of the card is near the first row of hooks or the beginning of the 26-row side of 51-row cards. It should be mentioned that in some districts the first row of the jacquard is taken to be that one at the beginning of the 25-row side of similar machines.

CHAPTER XII

THE RELATION BETWEEN THE JACQUARD MACHINE AND THE COMBERBOARD OR HARNESS REED

WE have already had occasion to refer to the methods of reading the design and cutting the cards, but in order to supplement the reference and to remove any doubt as to what actually occurs, we introduce in Fig. 178 six small weaves to represent sheets of design paper. The first weave A, in the way of the warp, is the $\frac{4}{2} \frac{1}{1}$ twill to right, and since the small mark * indicates the junction of the first thread and the first pick, it follows that the threads Nos. 1 to 8 of the design are read in the direction of the arrow.

When the first thread of the warp is on the left hand of the weaver, and is drawn through a mail in the back row of the comberboard or harness reed, as illustrated in Figs. 3, 5, and 9, the jacquard cylinder and the cards are at the back of the loom over the warp for the Nor-

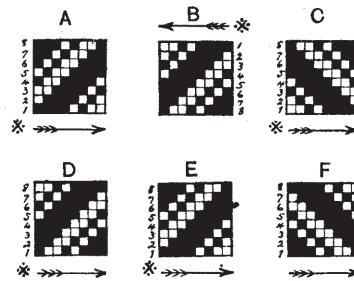

FIG. 178.

wich or straight tie. In this case the first hook is governed by a needle in the top row, and the hook is obviously in the back row. When the design A, Fig. 178, is taken to the piano card-cutting machine, it is turned through 180° , and placed on the reading-board in the position indicated at B, and the reading and cutting must be from right to left as shown by the arrow, although the numerical order of reading the rows of the design is clearly still from No. 1 thread onwards. Hence the first pick of the design is at the top in design B, and the straight edge would be immediately under this first pick line, and would be moved downwards after each pick.

If, for the same position of the cards and cylinder in the loom, the cutting starts from the bottom line of B, also from right to left, and the straight edge is moved upwards after each pick, it is clear that the last pick of the design will be cut first, and this card must obviously be

numbered accordingly. For example, the holes and blanks in the two rows on the four cards illustrated at A and B in Fig. 175, reading from the right hand to the left and downwards, correspond exactly with the marks and blanks of the picks 3, 4, 5, and 6 of design B, Fig. 178. The picks appear twice on each card. And evidently the same result could be obtained by cutting the cards in the order 6, 5, 4, 3, and arranging them as in Fig. 175. Consequently, when this or any other design is fixed on the reading-board, the cards may be cut in either of the following orders :

$$\begin{array}{l} 1, 2, 3, 4 \dots\dots\dots(n-2), (n-1), n \\ n, (n-1), (n-2) \dots\dots\dots 4, 3, 2, 1 \end{array}$$

—provided that care is taken to number the cards accordingly, so that they may be placed on the lacing frame in the order indicated at A or B, Fig. 175, or as in Fig. 173.

If, however, the same jacquard be placed on the loom in such a way that the cylinder and cards are at the front—that is, over the weaver's head—the first needle will be in the top row, but the hook which it governs will now be in the row at the front of the loom, and on the right-hand side of the weaver ; consequently the first needle and first hook of the machine will operate in reality the last thread of the warp, provided that the cloth is woven face side uppermost in the loom. At this stage it is assumed, for the sake of simplicity, that all the cloths are woven face upwards.

Now if the cards shown at A and B, Fig. 175, were operating the needles of the jacquard with the cylinder and cards at the front of the loom and over the weaver's head, as illustrated in Fig. 43, the twill and all the ornament of the design would be reversed in direction. Thus, the effect on the cloth would no longer be as illustrated at A, Fig. 178, but would appear as shown by design C in the same figure. It will be noticed that the order of movement in the threads in both designs A and C is $\frac{4-1}{2-1}$. Suppose, however, that the same eight cards (the middle four only of which are illustrated in Fig. 175) were laced backwards, that is, placed on the lacing frame so that the numbers would read 8, 7, 6, 5, 4, 3, 2, 1, from left to right, or in the order indicated by the four cards at C, Fig. 175, it will be found that the result in the cloth is identical with the design D, Fig. 178. This alteration will obviously have caused the twill to move to the right as in the original design A, but the movements of the threads in the two designs are different. Thus :

$$\begin{array}{l} \text{Each thread in design A is of the order } \frac{4-1}{2-1}, \text{ but} \\ \text{'' '' '' D '' '' } \frac{4-1}{1-2}. \end{array}$$

Evidently, then, the design on the cloth in the loom would be incorrect if viewed from the position occupied by the weaver. On the other hand, if

the cloth when removed from the loom were turned end for end—*i.e.* through 180° —the last pick inserted, or pick No. 8 of the design D, would be nearest the observer, and the effect in the cloth would then appear as indicated by the design E, Fig. 178, which is precisely the same as the original design A.

If, therefore, the cards which have been cut from the original design (say the twill A, Fig. 178) are laced backwards, and the first inserted pick considered, as it actually would be, the last horizontal line or pick of design A, the result in the cloth would remain unaltered, provided that the cloth is turned through 180° . The actual last thread of the warp would then become the first thread of the cloth. Hence, if all the threads of the warp are of the same count and colour, or if the colour scheme and threads are in the same order from the two selvages, any set of cards can be used as under :

1. Laced forwards when the cylinder and the cards are over the warp at the back of the loom, as in Figs. 10 and 44.
2. Laced backwards when the cylinder and the cards are over the weaver's head at the front of the loom, as in Fig. 43.

Similarly, if the cards which were cut from the design B, Fig. 178—*i.e.* design A turned through 180° —were laced backwards and placed on the loom with the cylinder and cards over the warp, the direction of the twill would be reversed, and would appear on the cloth as exemplified by the design F, Fig. 178. The order of the movements in this design is $\frac{+1}{-1} \frac{-2}{+2}$, but when turned through 180° it is $\frac{+2}{-2} \frac{+1}{-1}$, and identical with the design C.

Now suppose that the harness is drawn in with the first thread of the warp—that on the left hand of the weaver—in the front row of the comberboard or harness-reed, as in the lower diagram in Fig. 3, and that the cards and cylinder are at the back of the loom over the warp. The first needle in the jacquard would now be in the bottom row of the machine, and the first hook would naturally be in the front row over the weaver's head. In this case the design A, Fig. 178, would be placed on the reading-board in the same position as it appears in the illustration, and the reading and cutting would proceed from left to right. The straight edge would then be brought into line with the first pick—that is, under the first or bottom horizontal line of small squares of the design A, Fig. 178, and would be moved upwards one pick after each card was cut. The cards would be numbered 1, 2, 3, 4 . . . n , and it is clear that with this arrangement all the horizontal rows of small squares which had to be cut would be in sight—that is, not covered by the straight edge.

In a similar manner to that already described with reference to the loom where the draft of the harness is from back to front, it is also

necessary, when the harness is drawn from front to back, and when the cards occupy a position over the weaver's head, to have the cards from the design A, Fig. 178, laced backwards, 8, 7, 6, 5, 4, 3, 2, 1, in which case the effect on the cloth in the loom would be identical with the design shown at B, which is obviously a very similar effect to that shown in design A, and exactly the same if the design is viewed from the opposite end. The effect in the cloth would again be quite correct, if we consider the right-hand thread in the warp as the first thread with the cloth turned through 180° .

To illustrate still further the connection between the various points of the design and the needles, hooks, and threads of the loom, we shall assume that all the warp threads are white and that all the weft threads are black ;



FIG. 179.

this assumption will help considerably in regard to the consideration of the ornament on the upper and the lower surfaces of the cloth. Fig. 179 illustrates the ornament which is enclosed in the section B E in Figs. 108 and 109, with the exception of a small square area in each corner ; in these corners we have inserted the numerals 1, 2, 3, and 4. The correct view of the lion rampant obtains, of course, when Fig. 179 is turned 90° counter-clockwise ; the position illustrated, however, is correct so far as the design in Fig.

108 is concerned. The ground part of some point-paper designs is coloured and the figure left unpainted ; in most cases, however, it is usual to paint the ornament and leave the ground in the natural colour of the paper. This has been done in Fig. 179, although it is on plain paper and not on design paper ; the method therefore coincides in principle with that which was followed in the preparation of the actual point-paper design for Fig. 108.

When two distinct shades of yarn are used in weaving, it is, in general, better to employ the light-coloured yarn for the warp and the dark-coloured yarn for the weft : there are occasions when the reverse may be necessary. If the light-coloured yarn were used for warp, and Fig. 179 were transferred to design paper, the upper surface of the cloth would have a lion rampant developed in light warp on a dark ground, because painted areas

on the design paper are usually, although not invariably, cut to indicate warp threads on the upper surface of the cloth in the loom.

It has been stated elsewhere that damask designs, as well as several other types of designs, are woven face downwards, hence with light-coloured warp and dark-coloured weft the under side of the cloth in the loom woven from Fig. 179 would be represented by a dark figure on a light ground, because the figure would be developed by the dark weft. It will be found to be more convenient for demonstration purposes to reverse the method of painting, but before doing this we shall consider the disposition of the jacquards and comberboards.

With the Norwich or straight tie, the jacquard cards and the cylinder may occupy, as already mentioned, one of two positions, viz. :

1. At the back of the loom, where the cards would hang over the warp threads.
2. At the front of the loom, where the cards would hang over the woven cloth or above the weaver's head.

With the London tie, or quarter-twist tie, the jacquard cards and the cylinder are always at one or other end of the loom.

The positions of two groups of jacquard looms, four in each group for the Norwich tie, are illustrated in Figs. 180 and 181. In these diagrams the rectangles A, B, C, D, E, F, G, and H indicate the bottom board of the jacquard machine, while the narrower rectangles *a*, *b*, *c*, *d*, *e*, *f*, *g*, and *h* indicate the respective cylinders. The comberboards are under the bottom boards of the jacquards, and since the long sides of the comberboards and the long sides of the bottom boards of the jacquards are parallel to each other, it follows that the diagrams represent the Norwich or straight tie. The set-on handles for the eight looms are represented by two groups of solid circles S, four in each group, which therefore indicate the positions of the driving pulleys. Occasionally, and particularly for certain wide looms, there are pulleys at both ends, but the above disposition represents the usual arrangement for the bulk of looms.

In 51-row jacquard machines it is customary to have 26 rows of needles and hooks in one section and 25 rows in the other section, and when viewing the cylinder in the direction of the arrows in Figs. 180 and 181, the 26 row is on the right-hand side—*i.e.* where the small letters *a* to *h* are situated. The actual positions of No. 1 needle, hook, and thread depend upon custom, and vary in different districts.

In the first place, the threads of the warp may be drawn through the mails of the harness cords in two distinct ways :

1. From the back row of the comberboard or harness-reed to the front row, as exemplified in Fig. 180.

2. From the front row of the comberboard or harness-reed, as shown in Fig. 181.

The holes in the comberboard (eight in the illustrations for a 400's or

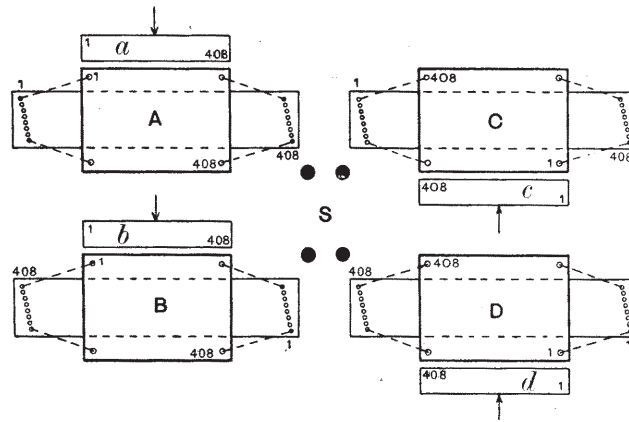

FIG. 180.

8-row machine, actual number 408 needles and hooks) are shown at an angle for clearness only; it will be understood that they appear practically, and in most cases absolutely, straight in practice. The order chosen makes no difference, of course, to the position of the outside threads, but

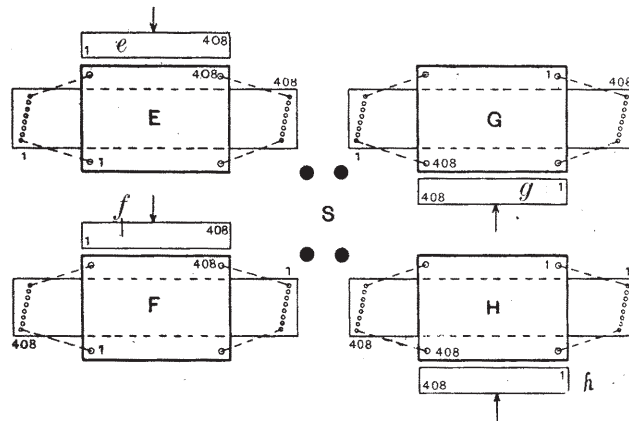

FIG. 181.

the two methods of drawing the threads demand attention and care in connection with all other parts and operations.

In the eight diagrams in Figs. 180 and 181 we have marked the positions of the first and last hooks (Nos. 1 and 408) in the machines, while the

corresponding positions of the holes in the upper face of the cylinders are also indicated by similar numbers. The dotted lines from the machine to the comberboard show which threads of the warp are controlled by the needles and hooks. Thus :

In looms A, D, E, and H, No. 1 hook controls No. 1 thread.
 „ B, C, F, and G, „ 1 „ „ No. 408 „

Fig. 1 shows the disposition of the chief parts of the jacquard as illustrated in looms A, D, E, and H, Fig. 180, while Fig. 2 shows the disposition of similar parts as illustrated in Fig. 181. The letters C and W in Figs. 1 and 2 indicate respectively the positions of the cards and the weaver ; they are on opposite sides of the comberboard in Fig. 1, but on the same side of the comberboard in Fig. 2.

Figs. 182 to 189 have been prepared specially to demonstrate the alterations which take place in the delineation of the ornament illustrated in Fig. 179, according to the position of the jacquard cylinder with respect to the loom, and to the method of cutting and lacing the cards. The illustrations, with the explanations, might constitute a scheme of instructions for cutting cards from different types of designs and for differently arranged looms.

The reader is asked to consider these figures as representing point-paper designs as well as representations of woven effects in the cloth, and, for simplicity, to consider each separate figure as occupying all the threads of the warp, unless otherwise stated. We might, for example, consider that each illustration is to occupy 408 threads, so that the number may correspond with that in the comberboards of Figs. 180 and 181.

The ornament in Fig. 182, with the exception of the size of the four numerals, is identical in outline with that in Fig. 179 ; it differs from it in that the black and white masses have changed places, and the numeral 3 has been altered in shape in order to make it unsymmetrical in all ways. Assuming that figured portions on the point-paper design had been left unpainted, and the ground portions painted as in Fig. 182, and that unpainted masses had been cut on the cards, it is clear that the ornament would be developed on the surface of the cloth with the white warp threads, and the ground of the fabric developed with the black weft.

Consider first the case where the cards have been cut and used on the cylinders of looms A and D, Fig. 180, with the face side of the cloth upwards in the loom. In these two looms the first thread of the warp is on the weaver's left ; while the last, or 408th, thread is on the weaver's right. If, while cutting the cards, the point-paper design in Fig. 182 were upside down, and the lines were read from right to left, the woven effect on the upper side of the cloth in the loom would be identical with Fig. 182, and

the numerals, as well as the remainder of the ornament, would be correct. By lacing the cards backwards the effect would be altered to that illustrated in Fig. 183; and although the lion rampant and the floral ornament would change only in direction if the cloth were turned through 180° , it will be evident that the numerals are also changed, and would consequently be quite wrong. Indeed, if we imagine that Figs. 182 to 185 represent one complete cloth in which the harness is centre-tied exactly at the middle,

FIG. 182.

FIG. 184.

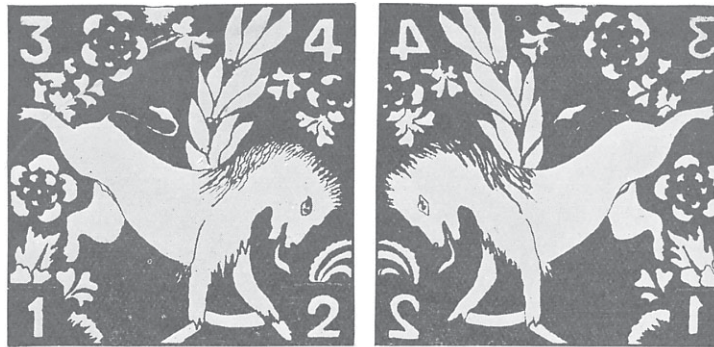

FIG. 183.

FIG. 185.

and the cards rotated forwards for half the number of picks and then backwards for the remaining half, we see a further demonstration of the case which has already been fully discussed in connection with Figs. 35 to 37, where it was shown that letters, numerals, and the like, which do not happen to be symmetrical, should be developed only by single and repeating ties, and not by centre-tied harness, nor by the combination of forward and reverse working of the cards.

Now consider the same set of cards used on the cylinders of looms B and C, Fig. 180. In these two looms the extreme right-hand thread of

the warp, that on the weaver's right, although marked 408, is really the first thread, because it is operated by No. 1 needle and hook, while the extreme left-hand thread is the last thread, because it is controlled by No. 408 needle and hook; hence the direction of all the ornament in Fig. 182 would be reversed on the cloth, and would appear as in Fig. 184. This shows conclusively that, although the animate and floral ornament might be acceptable, the numerals are all wrong. If, however, the same cards are laced backwards, the order of all the picks in Fig. 184 would be reversed, and the effect in the cloth would be identical with Fig. 185. This figure is, of course, upside down; but if the cloth be turned through 180° , the effect presented is precisely the same as that in Fig. 182. It will be understood that the above remarks refer, as already intimated, to a self-coloured warp; if differently coloured threads were required to develop the various parts of the design, the order of the colours in looms B and C, Fig. 180, would be reverse to that in looms A and D, in order that the weave structure and the colour scheme may work in unison.

From the above remarks it will be seen that if the cloth is woven face uppermost in the loom, the conditions are—

Cloth woven face upwards in loom. Design upside down on reading-board and cards cut from right to left.	A.	The cards should be laced forwards when the cylinder and the cards are over the warp beam at the back of the loom, as at A and D, Fig. 180.
		B.

We might, again, consider that Figs. 182 to 185 represent a complete cloth with the figures on the upper side of the cloth in the loom developed by white warp on a black weft ground. When such a cloth, composed of simple weaves and of single structure, is turned over from left to right, or *vice versa*, to exhibit what was the under side of the cloth in the loom, the result is obviously black weft figures on a white warp ground, as depicted in Figs. 186 to 189, the selvages having changed sides. The four designs in Figs. 186 to 189 are really exactly the same as those in Figs. 182 to 185, with the black and white masses changed, but it is the point of view of the front and back of the fabric that should claim sole attention here.

Suppose, for example, that the cloth upon which the figures are displayed should be woven face downwards in the loom; and that the design on the face side should be black weft on a white warp ground. To simplify matters again, consider only the ornament in Fig. 186 as being the correct design but on the under side of the loom, and that the cards had to be cut from the point-paper design represented by Fig. 182, unpainted portions of Fig. 182 being cut as before. With these conditions, and the cards cut from right to left as previously with the design turned through 180° on

the reading-board of the card-cutting machine, we should have developed on the upper surface of the cloth in looms A and D, Fig. 180 :

1. The effect in Fig. 182 when the cards are laced forwards.
 2. " " " 183 " " backwards.
- The reverse surface of Fig. 182 is that shown at Fig. 188.
 " " " 183 " " Fig. 189.

FIG. 186.

FIG. 188.



FIG. 187.

FIG. 189.

If now Fig. 189 be turned through 180° , the ornament and numerals would appear exactly the same as the ornament and numerals in Fig. 186, and precisely the same as the corresponding parts in Fig. 182, but black and white masses would have changed places.

With the same conditions, and the cards again cut from right to left from the design in Fig. 182 inverted, we should have on the upper surface of the cloth in looms B and C, Fig. 180 :

3. The effect in Fig. 184 when the cards are laced forwards.
 4. " " " 185 " " backwards.
- The reverse surface of Fig. 184 is that shown at Fig. 186.
 " " " 185 " " Fig. 187.

And the ornament and numerals in Fig. 186 are exactly the same as those in Fig. 189 when the latter is turned through 180° , and just the same as the corresponding parts in Fig. 182, but black and white masses have changed places.

It would thus appear that if the point-paper design corresponding to Fig. 182 is inverted on the reading-board, and the cards are cut from right to left from unpainted portions, the under surface of the cloth in the loom is correct under the following conditions :

Cloth woven face downwards in loom. Design upside down on reading-board and cards cut from right to left.	}	C. The cards should be laced backwards when the cylinder and the cards are over the warp beam at the back of the loom, as at A and D, Fig. 180.
		D. The cards should be laced forwards when the cylinder and the cards are over the weaver's head at the front of the loom, as at B and C, Fig. 180.

In some linen damask factories where the cloths are woven face downwards, all the cards for mottoes, names, and the like are laced backwards (and not forwards as mentioned in part D), and the cloths woven in looms in which the cylinder and the cards are over the weaver's head. In such cases, however, the design is made for the right-hand corner of the cloth—that is, similar to the effect in Fig. 184 instead of as Fig. 182—and the design placed the right way up on the reading-board. The use of the same type of loom, with reference to the position of the cylinder, is the practice adopted with the object of preventing any alteration in the lacing of the cards. In other factories, on the other hand, such cloths are woven in any suitable loom which happens to be at liberty, and the cards laced according to the position of the cylinder of the jacquard with respect to the loom.

It will be seen that no alteration in the relative positions of the parts of the design will take place whether the figure or the ground of the design is painted on the point-paper ; the ground was assumed to have been painted in the foregoing description. If, however, we assume black warp and white weft, with figure parts painted on the design-paper, the results will be identical with those described in the foregoing discussion. It is only in special cases or special types of designs that the painting has anything to do with the actual colour scheme of the warp or weft. As a matter of fact, both warp and weft are the same colour in a great number of figured cloths.

As already stated, the foregoing description has reference to the case where the design is turned through 180° , and therefore placed upside down on the reading-board of the piano card-cutting machine, as exemplified in the diagram in Fig. 190. Hence, the actual first pick, or first horizontal line of the design, is at the top, and, if the cards are cut in the natural order of numbering, the horizontal straight-edge would be moved down-

wards in the direction of the arrow A as the cutting proceeded. The direction of reading and cutting was taken to be from right to left as indicated by the arrow B.

If, however, the design be placed the right way up on the reading-board of the piano card-cutting machine, as indicated in the diagram in Fig. 191, the first pick or first horizontal row of small squares would clearly be at the bottom, and the straight-edge may be moved upwards, line after line, as indicated by the arrow C. It need hardly be said that the straight-edge may be moved either up or down for either disposition of the point-paper design, and according to which arrangement happens to be suitable for the operator; the only thing to remember is that the numbering of the cards must correspond to the numbers of the picks. In both cases, as demonstrated in Figs. 190 and 191, the numbering would

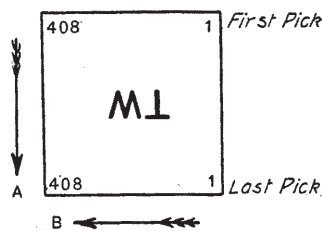

FIG. 190.

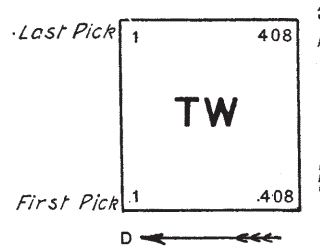

FIG. 191.

be: 1, 2, 3 . . . 408. Should the movement of the straight-edge be changed in both cases, the numbers would be: 408, 407 . . . 3, 2, 1.

Now let us suppose that the design-paper is placed the right way up on the reading-board, as exemplified in the diagram in Fig. 191, and that the horizontal rows of small squares, or picks, are read, as in the first case, from right to left as indicated by the arrow D; everything would be reversed as compared with the results from the other diagram, and we should have the following:

- | | | |
|---|---|---|
| Cloth woven face upwards in loom. Design right side up on reading-board and cards cut from right to left. | { | E. The cards are laced backwards when the cylinder and the cards are over the warp beam at the back of the loom, as at A and D, Fig. 180. |
| | | F. The cards are laced forwards when the cylinder and the cards are over the weaver's head at the front of the loom, as at B and C, Fig. 180. |
| And | | |
| Cloth woven face downwards in loom. Design right side up on reading-board and cards cut from right to left. | { | G. The cards are laced forwards when the cylinder and the cards are over the warp beam at the back of the loom, as at A and D, Fig. 180. |
| | | H. The cards are laced backwards when the cylinder and cards are over the weaver's head at the front of the loom, as at B and C, Fig. 180. |

The complete particulars for both kinds of looms in Fig. 180, and for right to left cutting of the cards, appear in Table V. :

TABLE V.

Cloth Woven FACE UPWARDS.	Looms A and D.	Looms B and C.
DESIGN UPSIDE DOWN ON BOARD : Direction of reading design Method of lacing cards Order of coloured threads in the loom .	RIGHT TO LEFT. FORWARDS. LEFT TO RIGHT.	Right to left. Backwards. Right to left.
DESIGN RIGHT SIDE UP ON BOARD : Direction of reading design Method of lacing cards Order of coloured threads in the loom .	Right to left. Backwards. Right to left.	RIGHT TO LEFT. FORWARDS. LEFT TO RIGHT.
Cloth Woven FACE DOWNWARDS.	Looms A and D.	Looms B and C.
DESIGN UPSIDE DOWN ON BOARD : Direction of reading design Method of lacing cards Order of coloured threads in the loom .	RIGHT TO LEFT. BACKWARDS. LEFT TO RIGHT.	Right to left. Forwards. Right to left.
DESIGN RIGHT SIDE UP ON BOARD : Direction of reading design Method of lacing cards Order of coloured threads in the loom .	Right to left. Forwards. Right to left.	RIGHT TO LEFT. BACKWARDS. LEFT TO RIGHT.

When the warp contains differently coloured threads the arrangement in small capitals appears to be the best, because the order of warping the coloured threads need not be altered to suit the changed conditions in the loom. If, however, all the threads of the warp are the same colour, as in many types of linen, cotton, and silk figured fabrics—*e.g.* damasks—the simpler way when changing from looms A and D to looms B and C is to use the same or a similar set of cards, but to lace them backwards. The great advantage of the latter method is that the same set of cards can be utilised for both kinds of looms when the cards are laced in the correct order, whereas in the other method it is necessary to consider the relation between the colours of the threads and the positions of the needles and hooks which control them. It is of course just as easy to cut the cards with the design one way on the board as the other way; and if one loom only had to be provided with a set of cards, there would be little to choose between the methods. On the other hand, however, if several looms were to be engaged on the same pattern, and with self-coloured

warps, a distinct advantage would obtain when one set of cards only had to be cut on the piano card-cutting machine, and all the remaining sets prepared on the card-repeating machine, using this first set as a pilot set.

When the designs are comparatively short in the way of the weft, and two sets of cards for different looms can be accommodated between two ordinarily pitched looms, and the cards therefore always arranged over the warp beams, the above-mentioned difficulties never appear; but there is not sufficient space for two very long sets of cards between ordinarily pitched looms; indeed, there is often little enough space for the cards for one design and loom, and particularly is this the case for certain types of cross-bordered fabrics and the equivalent of such—*e.g.* those illustrated in Figs. 37, 39, 40, and 41. For work of this kind two sets of cards are invariably required, each set containing hundreds of cards.

The method of drawing the warp threads from back to front of the comberboard or harness-reed, as illustrated in Fig. 180, is practised in many centres where jacquard weaving is extensively conducted; in other centres the method of drawing in the threads is that illustrated in looms E to H, Fig. 181. For such an arrangement of draft it is usual to read the design from left to right when cutting the cards, because the bottom needle of the jacquard—that which controls the hook marked No. 8 in Fig. 1—controls the thread nearest the weaver. And since the draft in the harness is reversed, and the order of cutting is reversed as exemplified in Figs. 190 and 191, the above particulars will do for both orders.

The various positions of the needles and hooks relative to the comberboard or harness-reed, and with respect to the two methods of drawing the warp threads through the mail of the harness in conjunction with the Norwich or "Straight" system of harness tie, are illustrated fully in Figs. 180 and 181. With the London or "Crossed" tie, in which the harness cords have a quarter twist, the long sides of the jacquard and cylinder are at right angles to the long sides of the comberboard or harness-reed, as exemplified in Figs. 192 and 193; eight different diagrams are again exhibited. The first four (J, K, L, and M in Fig. 192) are typical of the back-to-front method of drawing in the threads, while the remaining four (N, O, P, and Q, Fig. 193) are representative of the front-to-back method of drawing in the threads. If we place the 16 diagrams from Figs. 180, 181, 192, and 193 as under—

A	B	C	D	E	F	G	H
J	K	L	M	N	O	P	Q.

we may assume that to all intents and purposes the two in each vertical row are identical. Thus if we examine the position and numbers and the method of drawing in the threads in diagram A, Fig. 180, and compare

these with the corresponding parts of diagram J, Fig. 192, we shall find them exactly the same. Further, if we assume that the bottom board of the jacquard A, Fig. 180, is turned one-quarter counter-clockwise, the

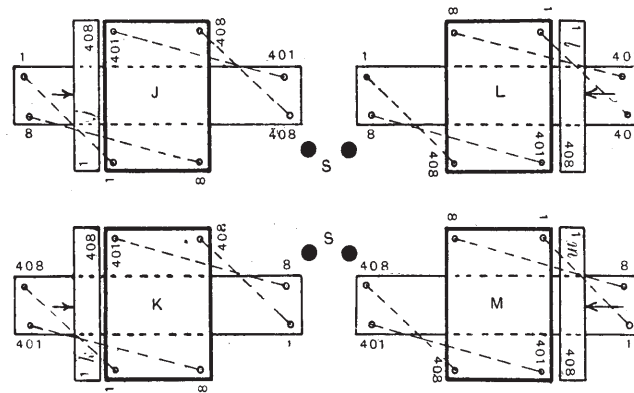

Fig. 192.

parts will appear identically with those at J in Fig. 192. Hence any set of cards which were used on cylinder *a*, Fig. 180, could be transferred to cylinder *j*, Fig. 192, and the cloths produced in the two looms would be absolutely identical so far as the outline and weaves of the design were

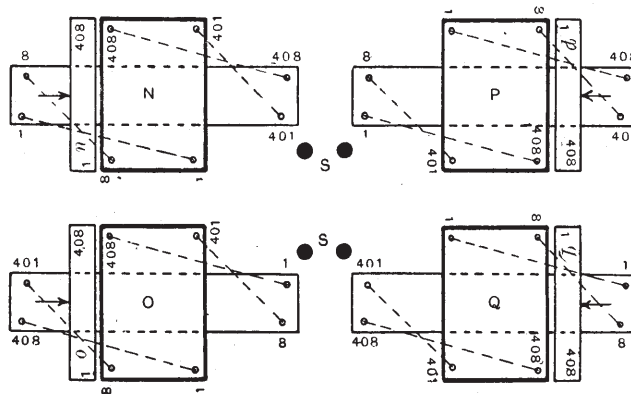

Fig. 193.

concerned. It will also be observed that in both diagrams the looms are right-hand ones, because the handle is on the right-hand side of the weaver. The two left-hand looms, B, Fig. 180, and K, Fig. 192, may be compared in the same way, and so may all the other machines represented by the vertical pairs in the above letters A to Q. The solid black circles S in

Figs. 192 and 193 represent, as in Figs. 180 and 181, the positions of the set-on or control handles, and it will be seen that in the three figures all positions are illustrated.

We have now explained at length the conditions regarding the relation between the first thread of the cloth and the so-called leading hook and needle of the jacquard for all positions of the jacquard with respect to the comberboard or harness-reed, and for the two distinct methods of drawing in the warp threads through the mails of the harness. In regard to the draft of the harness, we have assumed the simplest of all cases—*i.e.* that in which the number of hooks in the jacquard is exactly the same as the number of threads in the warp. Modifications of drafting have to be introduced for certain kinds of fabrics, but this branch of the subject has already been considered.

When the jacquard is placed above the loom so that the long rows of hooks are parallel to the short rows of the comberboard or harness-reed—*i.e.* for the London or crossed tie—the cards must obviously be near one end of the loom, as demonstrated in Figs. 192 and 193. The pulleys for one row of looms, right and left hand, are all in one row, and it is a common and almost invariable practice to have all the different sets of cards for one row of looms on one side, usually nearest the pass, *i.e.* furthest removed from the set-on positions. S; occasionally, however, the cards are on the driving side. If the cards are at the opposite end to the driving end, it follows that in a right-hand loom the cards of the jacquard will be on the left-hand side of the loom and of the weaver, whereas in a left-hand loom the cards will be on the right-hand side of the loom and the weaver. Under such conditions it will be found that the connection between the hooks and threads in a right-hand loom, arranged for the London tie, corresponds with that in a loom arranged for the Norwich tie, where the cards are over the warp at the back of the loom. And naturally the conditions for a left-hand loom, London tie, correspond with those of a loom with the Norwich tie and the cards over the weaver's head. The remarks on page 18⁶, however, in connection with London ties, should be kept in mind.

CHAPTER XIII

MECHANICAL METHODS OF LACING AND STITCHING CARDS

THERE are two distinct methods employed for this important work :

1. Where two sets of cords or lacing twine, single or double, are interlocked to hold the cards more or less securely between them.
2. Where two sets of tapes, one set under the cards and the other set over the cards, are secured to the cards by a system of sewing or stitching.

The order in which these machines are taken in this work does not necessarily indicate a difference in the respective merits of the various machines, but is adopted solely to suit the requirements of the author. Each well-known machine is extensively employed, and all are capable of producing satisfactorily laced cards.

The main requirements of mechanical lacers are—

1. An automatic or semi-automatic feeder or method of carrying the cards to the lacing mechanism, and of delivering them after they are laced.
2. Lock-stitch mechanism, if ordinary needles are used, and in all other cases if possible.
3. Thread take-up mechanism to reduce the stress to a minimum, and still to impart the necessary degree of tension to the lacing twines.
4. Provision for all the required rows of lacing to be performed simultaneously.

The modern card-lacing machine as made by the Singer Manufacturing Company Limited will be described and illustrated first, but before describing the complete machine we purpose introducing a few of the chief parts by means of which the above desirable and requisite functions are performed.

Three positive box cams, all secured to the main shaft of the machine, are employed for this purpose ; they are—

- A, Fig. 194, for operating the needles and the thread take-up levers.
 B, Fig. 195, for operating the shuttle carriers and the shuttles.
 C, Fig. 196, for operating the card feed wheels.

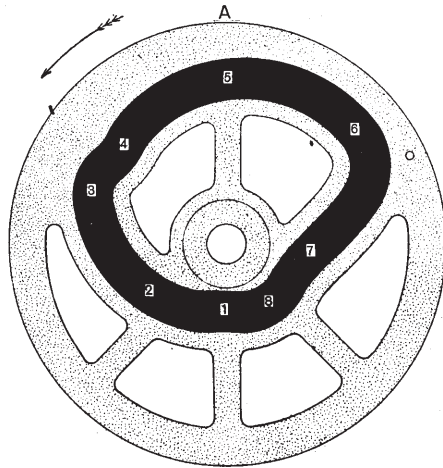

FIG. 194.

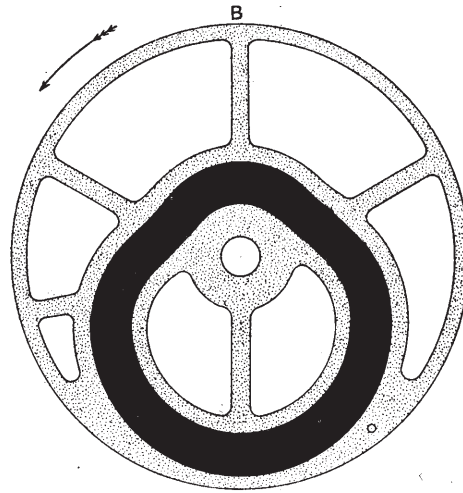

FIG. 195.

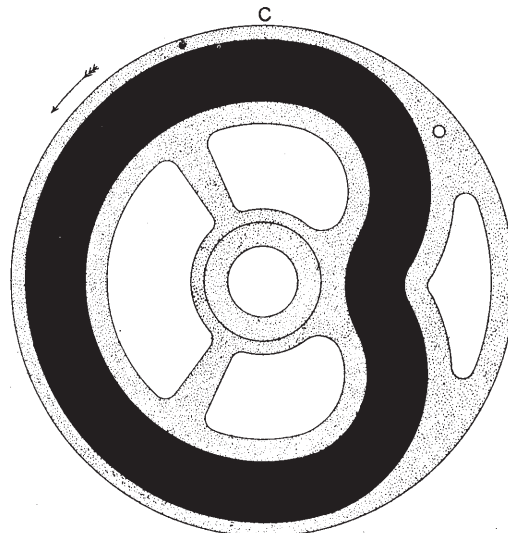

FIG. 196.

These three cams are essential whether the machine is driven by power or by foot, and the positions which they occupy are indicated in Figs.

197 and 198, as well as in subsequent illustrations. The main shaft D extends the full length of the machine, and when the machine is arranged to be driven by power the main shaft carries the loose and fast pulleys E and F, as shown in Fig. 197. This is a perspective view of the front of a 5-head machine, while Fig. 198 is a similar view of a 4-head machine intended to be driven by foot-power, and which requires one pulley only—the fast one.

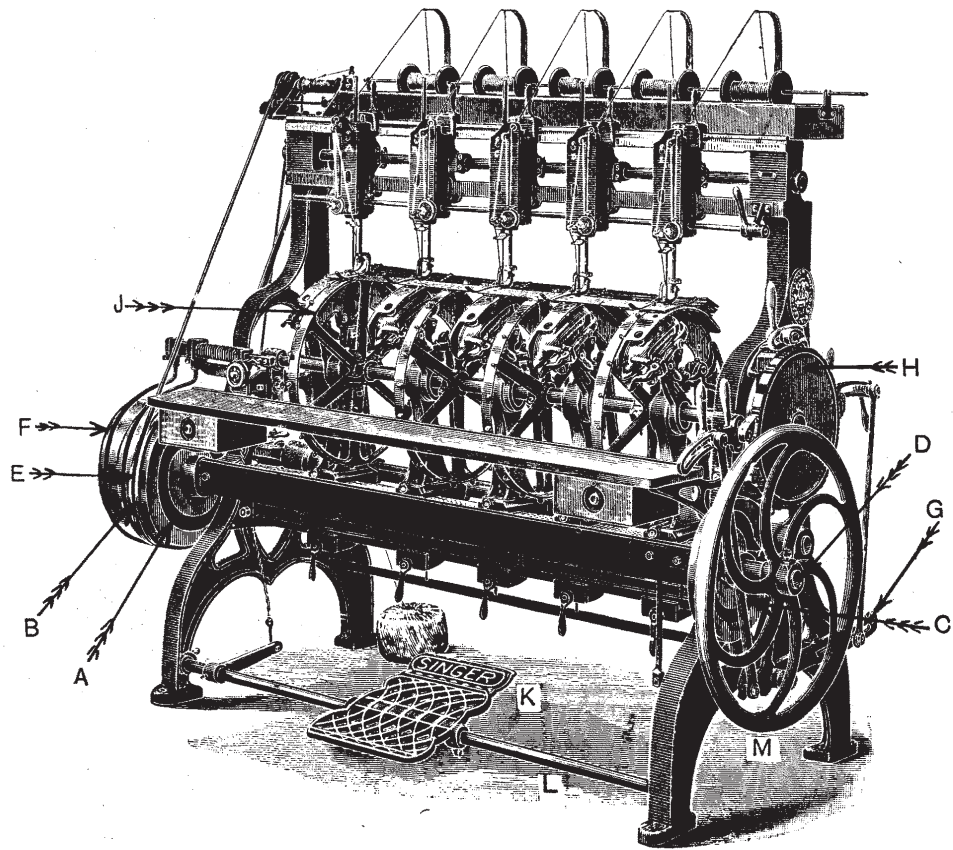

FIG. 197.

Fig. 198 shows clearly the cam C which actuates the three-armed lever G, shown separately in Fig. 199. The lever G, by means of connecting-rods and pushing pawls, drives the feed ratchet wheel H, and hence the feed-wheels J and J'. The arrangement for driving the machine by foot-power is shown in Fig. 198. The treadle K on shaft L must obviously be operated by the attendant, and the oscillations imparted thereto are made to drive the balance and hand wheel M through the lever N, the

connecting arm O, and a suitable crank on the end of the shaft P. On the opposite end of the shaft P is a pulley Q from which the main shaft D is driven by the belt R.

In power-driven machines the balance and hand wheel M is placed on the main shaft D, as shown in Fig. 197. In machines which are built specially and solely for power work it is a usual practice to dispense with the shaft P and the pulley Q, Fig. 198, and in the subsequent line drawings, as well as in Fig. 197, these parts are omitted.

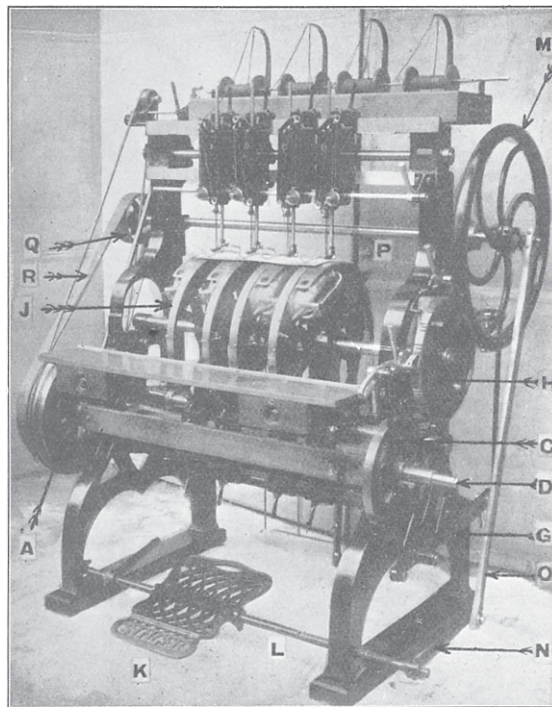

FIG. 198.

The speed of the machine depends chiefly upon the dexterity of the attendant, for since the feed-wheels J and J¹ move intermittently on the shaft D, which moves at a constant speed, it is evident that a card must always be in position to be drawn forward under the needles, otherwise a gap would result and the machine would have to be stopped. A good speed for this class of machine is 60 to 70 revs. per min. of the main shaft D, and, of course, of each of the cams A, B, and C, Figs. 194 to 196, which rotate with it.

Perhaps the most satisfactory way of describing the machine will be to take the mechanism for each individual operation separately, and then to show how all the parts must move in unison with each other to produce correct work.

Complete views of the mechanism are displayed in Figs. 200 to 214. Fig. 200 is an elevation of the driving end; Fig. 201 is an elevation of the opposite end; Fig. 202 is a front elevation of a three-head machine—the type required for lacing jacquard cards for 400's and 600's machines of the ordinary pitch. The remaining figures refer more particularly to sectional views and to special parts.

The feed-wheels J and J¹ are made in halves, as illustrated in the special view in Fig. 203 ; each pair is fixed together by set-screws as shown on the feed-shaft S. A box-key, shown suspended from two screw-nails in Fig. 202, is provided for this purpose, since it is sometimes necessary to change the positions of the wheels on the shafts, and at other times it is necessary to remove the set of wheels for the purpose of introducing another set to lace cards of a different width.

The two outer feed-wheels J, Fig. 203, are provided with a number of pegs or studs T which pass through the peg holes—one at each end of the card—in the usual manner ; if there are intermediate peg holes, as is sometimes the case in long cards, an intermediate peg wheel is used with similar pegs fixed at the proper position on the shaft. In general, there are the same number of peg feed-wheels as there are peg holes in the length of the card. The total number of feed-wheels, however, is determined by the number of rows of lacing, and from what has been already said

about this subject it is clear that for 8-row 400's and 12-row 600's jacquard cards of the ordinary pitch there are three sets of lacing twines ; hence, for such cards, a third feed-wheel, the middle one marked J¹ in Figs. 202 and 203, is provided for the centre line of lacing. It is obvious,

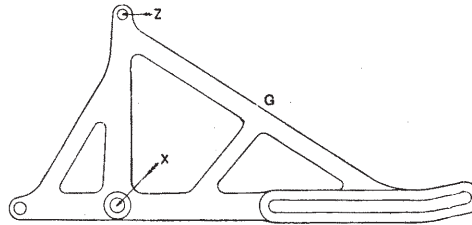

FIG. 199.

however, that pegs must not be inserted in the middle wheel J¹, since there are no corresponding peg holes in the card. This feed-wheel, however, is provided with thin metal projections T¹, Fig. 203, which are fixed on the periphery of the feed-wheel J¹ in such a way that each one is midway between the pegs T on the periphery of the feed-wheels J ; thus the cards 26 lie between these thin metal projections, while the peg holes on the cards fit on the pegs T. The arrangement is clearly shown in the figure where the end bits of two cards are on the pegs T of the feed-wheel J on the left, and the middle bits of the same two cards are between the thin metal projections T¹ on the feed-wheel J¹ on the right.

The distance between each pair of pegs T and each pair of projections T¹ obviously depends upon the width of the card. If there are two peg holes in each end of the card it is unnecessary to introduce a peg for each hole ; one is quite sufficient at a place to carry the cards forward. The circumference of the feed-wheels for all widths of cards is practically the same, differing only by a fraction of an inch, and hence the number of pegs in the circumference of the feed-wheel is practically inversely

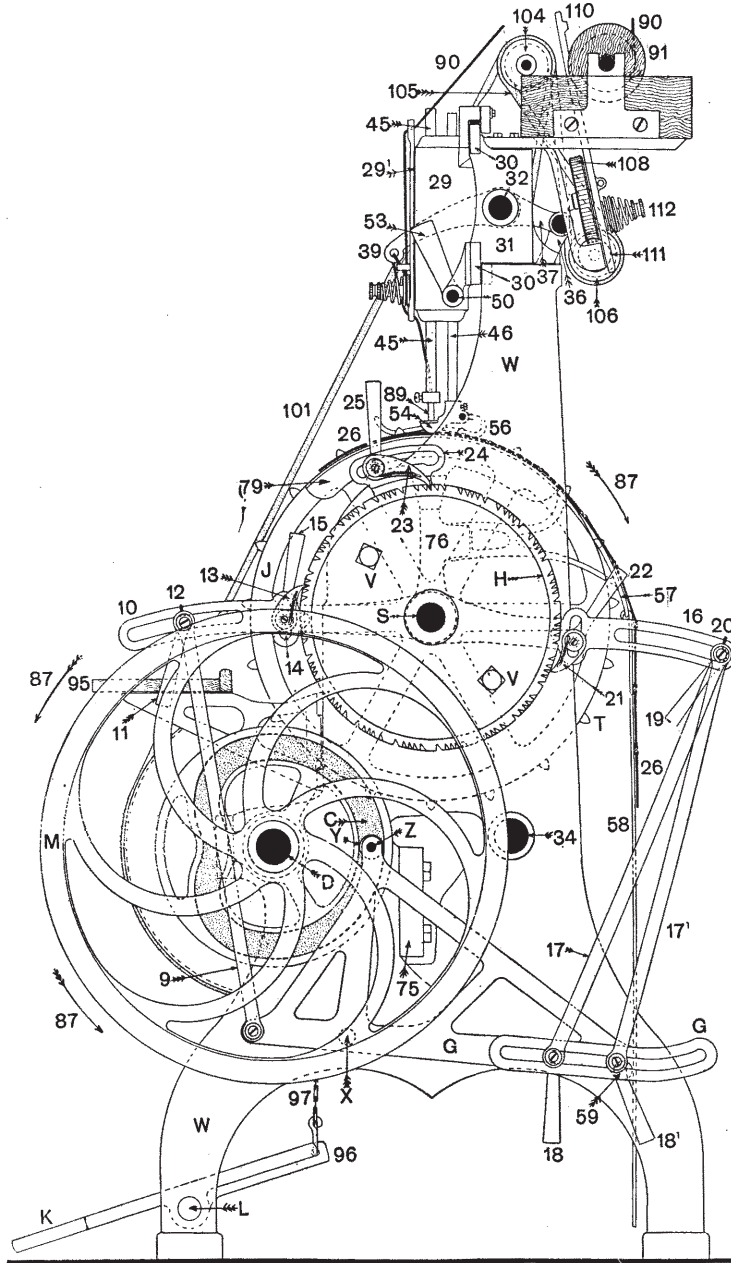

FIG. 201.

proportional to the width of the card. The actual numbers for three common types are as under :

For 8-row ordinary pitch cards (400's) there are 21 pegs ;

For 12-row ordinary pitch cards (600's) there are 15 pegs ;

For 8-row Brussels-carpet jacquard there are 19 pegs ;

and so on for the other less-widely used machines.

Fixed near the end of the feed-shaft S, Fig. 202, is the feed ratchet carrier disc U, and to this disc is fixed the feed ratchet wheel H by means of set-screws V, Fig. 201. The feed-wheels J and J¹ as a body and the feed ratchet wheel H must obviously move forward intermittently through distances which are equal to the gaps between the holes on the cards themselves and the gaps between the outside holes of the cards and the opening between each pair of cards. These distances vary in different cards, and are not all the same on any card ; hence the movement of the feed-wheels J and

J¹ is of rather a complicated character. When, however, the correct distance has been fixed, the various movements are very accurate, and there is little or no danger of any faulty distances. It will be understood,

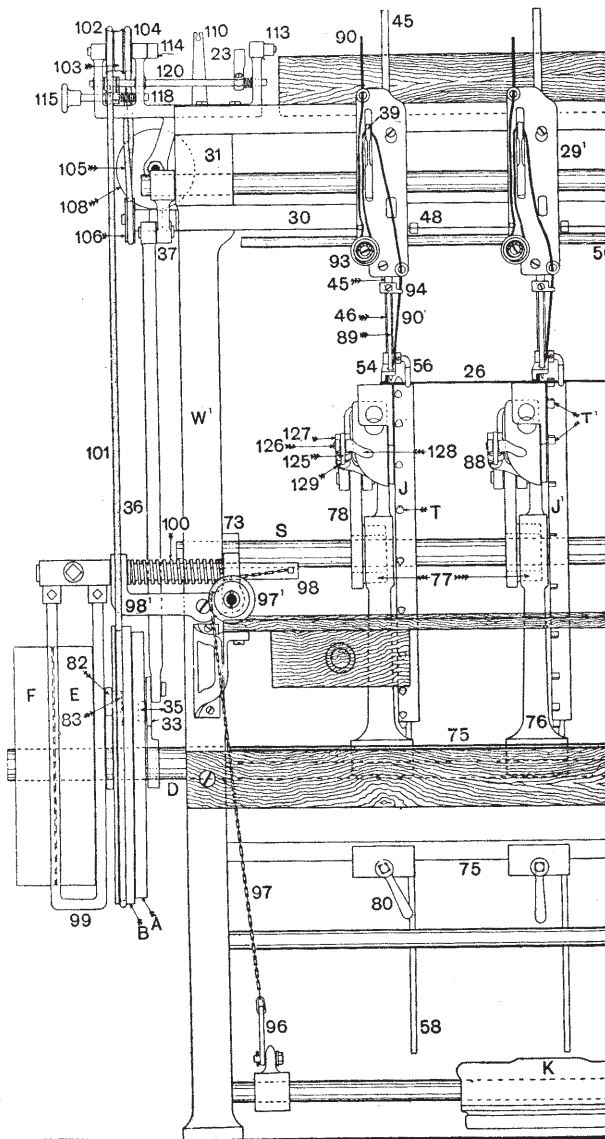

FIG. 202.

of course, that the movement of the feed-wheels takes place only when the needles are above the card.

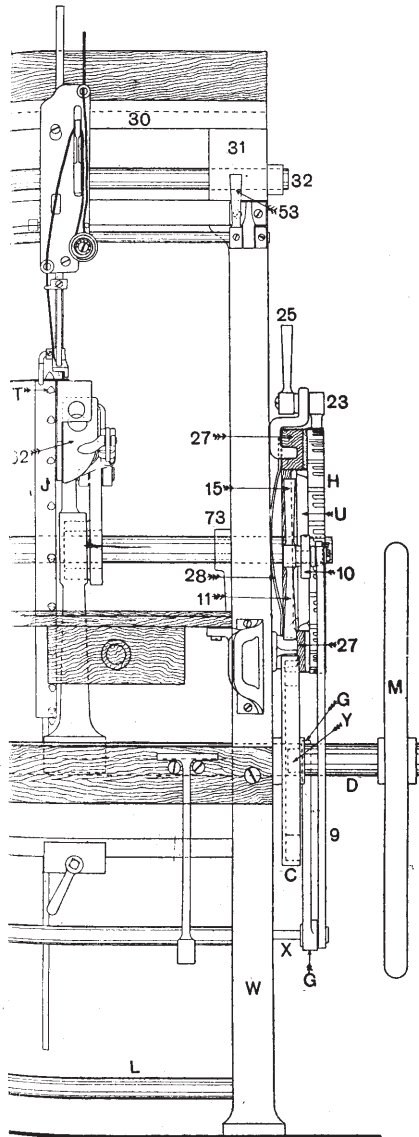

FIG. 202.

23 is adjustably fixed in the slot of the bracket 24 by handle 25. Each pawl 13, 21, and 23 is provided with a light spring as shown, which tends to keep the point of the pawl in close contact with the feed ratchet wheel H.

To simplify the description as much as possible, we shall assume in all cases, when considering the movements of the cams, that the observer is at that end of the machine illustrated in Fig. 201. In this view the feed ratchet wheel cam C is between the frame W and the balance-wheel M (see also Fig. 202), while the three-armed lever G, fulcrumed on a stud X in the frame W, is between the cam C and the balance-wheel M.

The vertical arm of the three-armed lever G carries an anti-friction roller Y, supported on a pin Z, and hence capable of rotating freely in the groove of the cam C. A connecting-rod 9, Figs. 201 and 202, joins the short arm of lever G to the pawl lever 10, and is fixed in the proper position in the concentric slot of pawl lever 10 by the handle 11, while a small projecting pin or pointer 12 serves to locate the proper position with respect to marked places on the upper surface of the pawl lever 10. This lever is fulcrumed loosely on the feed-shaft S, Fig. 201, and its pawl 13 is fixed in the vertical slot 14 of the pawl lever 10 by means of the handle 15. In the slot of the long arm of lever G, and in the slot of another pawl lever 16, Fig. 201, is fixed a connecting-rod 17 by handles 18 and 19, while a similar indicator 20 is provided in the upper end of the connecting-rod 17. Similarly, the pawl lever 16 is fulcrumed loosely on the feed-shaft S, and is provided with an adjustable pawl 21 and fixing handle 22. Finally, a retaining catch

The positions of the various parts in Fig. 201 and the type of feed ratchet wheel illustrated there, and in the complete view in Fig. 204, are

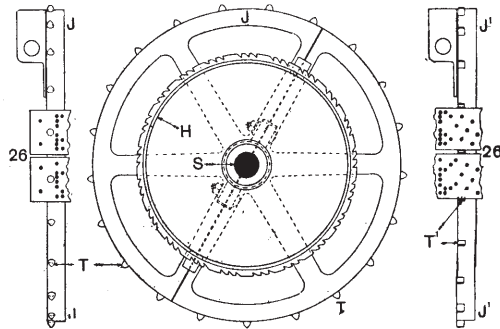

FIG. 203.

those which are necessary for the 8-row Brussels carpet jacquard cards. When the same lacing machine is intended to be employed for lacing different sizes of cards it is necessary to have, as already indicated, suitable feed-wheels J and J' for each set, as well as a differently cut feed ratchet wheel H to give the correct movements to the group of feed-

wheels. In addition, it is necessary to move the upper end of connecting-rod 9 to the proper position in the slot of the pawl lever 10, and to move both ends of the connecting-rod 17 in the slots of levers G and 16. It is obviously impossible to show all the positions, but in Fig. 201 the lower end of the rod 17 has been moved as indicated by 17¹ and the handle 18¹ to the approximate position which would obtain when the machine was arranged to lace cards for an ordinary 8-row 400's jacquard.

If the reader refers to the Brussels-carpet jacquard card illustrated in Fig. 99, he will see that on each card, and in every short row for lacing, there are four holes. These holes, with the gap between each pair of cards, make it essential that each lacing needle shall pass down and up five times each way for each card. Hence the sequence of the teeth in the feed ratchet wheel H is five, as is shown clearly by the Roman numerals on the elevation and plan of a section of the feed ratchet wheel, lettered H in Fig.

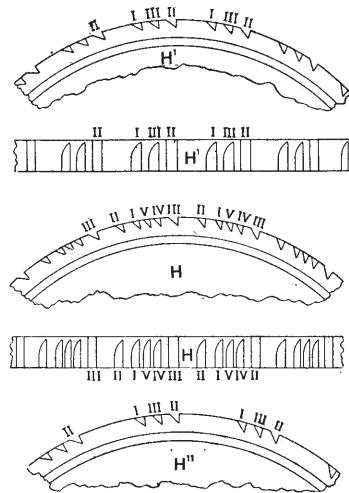

FIG. 204.

204. It will also be observed that one tooth only in each set, that marked III., is cut right across the face of the wheel—the others extend only partially across, and hence leave perfect concentric sections between each pair of fully-cut teeth III. The similar elevation and plans of sections of feed ratchet wheels lettered H¹, and the elevation H¹¹, repre-

sent those which are used respectively for 400's and 600's cards, and for similar pitch 8-row and 12-row cards of different lengths. In both of these wheels there are two partially-cut teeth and one fully-cut tooth in each sequence, because in these cards there are only two lacing holes in the short row of cards and the usual gap between each pair of cards. In the five movements indicated by Roman numerals for the Brussels-carpet jacquard card, the middle number III. is for the comparatively long movement in the middle of the short rows on the card. In the 400's and 600's cards the three movements are represented by three Roman numerals and the middle number II. is that for the long stitch on the card.

To return to Fig. 201. It should be mentioned at once that the right-hand pawl 21 extends across the full width of the face of the feed ratchet wheel H, and can thus enter only into that tooth, or rather the recess III., which is fully cut. Moreover, it is this pawl which imparts the greatest movement to the feed ratchet wheel H, and hence to the feed-wheels J and J¹ and the card 26. The cards in Fig. 203 have been made with two lacing holes only in the width: this has been done for the sake of showing up the lacing rows distinctly; and although the feed ratchet wheel is for the Brussels-carpet jacquard cards, these sections of cards may be looked upon as being for a 400's jacquard machine of the ordinary pitch. The big movement for such a card, and the still bigger movement for the corresponding place in a 600's card, are both obviously greater than the corresponding movement required for the central portion of the Brussels-carpet card; this is easily seen by comparing the gaps immediately to the right of the recesses numbered III. and II. in the sections lettered H, H¹, and H¹¹ in Fig. 204.

Without referring particularly to the movements of the needle, it will be seen that in Fig. 201 it is near its lowest position, and consequently no movement of the feed ratchet wheel H or the feed-wheels J and J¹ is possible. As a matter of fact, the needle is down below the card for a comparatively long period, so that the feed ratchet wheel H and the feed-wheels J and J¹ are kept stationary for this period by that part of the cam C, Fig. 196, which forms part of a true circle for approximately half a revolution. The anti-friction roller Y, Fig. 201, is therefore on its extreme right; whereas, when the cam C has rotated to the position indicated in Fig. 196, the bowl Y will be in the extreme left position—*i.e.* nearer the shaft D, Fig. 201—and the long and short arms of the three-armed lever G will thus have carried their respective pawl levers 10 and 16 to their lowest and highest positions ready for one or other of the pawls 13 and 21 to act on the feed ratchet wheel H. In Fig. 201 these arms have already acted, and are in their highest and lowest positions. The shaft D rotates counter-clockwise, as viewed from Fig. 201; hence, as the

anti-friction roller Y is approaching the shaft D the pawls 13 and 21 are moving to the active position, whereas when the anti-friction roller Y is moving towards the periphery of the cam C one of the pawls 13 or 21 is pushing the feed ratchet wheel clockwise through the distance required, such distance being determined by the particular part of the card which had been immediately under the needles.

Any position in the revolution of the main shaft D could naturally be selected as a starting point to describe the complete action; the one which we have taken is that represented in Fig. 201, where the needle is at present down between two cards of the Brussels type, or at that point lettered A in Fig. 205. The four holes in the card are lettered B, C, D, and E to the left, because these letters will appear in their proper alphabetical order as the card moves to the right. A further enlarged view of part of the face of the feed ratchet wheel H is also reproduced in this figure, but not to the same scale as the cards. The various sections for one round, or rather cycle, necessary for the movements for the lacing of one card are marked by Roman numerals, I., II., III., IV., and V., as before, and also, in addition, by small letters between the numerals. Since the movements of the shuttle, and also the needles, will be required shortly, we introduce the following table, which shows the extreme positions of both, as well as the positions of the pawls 13, 21, and 23, for each complete revolution of the main shaft D, Fig. 201 :

TABLE VI.

Letters on and between the Card 26.	Position of Needle.	Position of Shuttle.	Position of Left Pawl 13 on Wheel H.	Position of Top Pawl 21 on Wheel H.	Position of Right Pawl 23 on Wheel H.
A	Down	Back	V.	V.	<i>b.</i>
A	Up	Front	I.	V	<i>e.</i>
B	Down	Back	I.	I.	<i>a.</i>
B	Up	Front	II.	I.	<i>d.</i>
C	Down	Back	II.	II.	<i>e.</i>
C	Up	Front	<i>d.</i>	II.	III.
D	Down	Back	III.	III.	III.
D	Up	Front	IV.	III.	V.
E	Down	Back	IV.	IV.	<i>e.</i>
E	Up	Front	V.	IV.	<i>a.</i>

In all cases, for this wheel and for any other, the right pawl 21 operates only on the feed ratchet wheel when it can enter the fully-cut recess marked III. in H and II. in H¹ and H¹¹, Fig. 204; while since both pawls 13 and 21 move simultaneously, it follows that the left pawl 13 will, at this time, be ineffective on the broad part *d*, Fig. 205, between II. and III. The arrows from the various parts of the upper lacing twine in Fig. 205 to the recesses in the section of the feed ratchet wheel H show which tooth or

recess is acted upon for the length of twine between the letters. Pawl 13 acts on four of the short recesses, and pawl 21 on the fifth.

The movements of the feed ratchet wheel H for the 400's and 600's cards are much simpler than the above. In general, when these cards for 400's and 600's machines are being laced, and when pawls 13 and 21 are just ready to push the feed ratchet wheel, one or other of the pushing pawls will be in touch with a recess, but the one which for the moment is not in contact with a recess, or which is unable to enter a recess, is marked 0 in the following table to indicate that it can have no effect at this particular time. The Roman numerals show which recesses the various pawls are in contact with (refer to H¹ and H¹¹, Fig. 204):

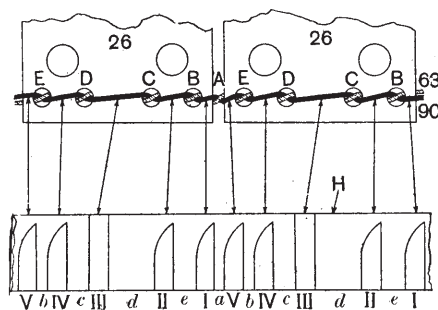

FIG. 205.

TABLE VII.

Pawl 13 . . .	III .. I .. 0 .. III .. I .. 0 .. III .. I .. 0 ..
Pawl 21 . . .	0 .. 0 .. II .. 0 .. 0 .. II .. 0 .. 0 .. II .. 0 .. II ..
Pawl 23 . . .	III .. I .. II .. III, .. I .. II .. III .. I .. II ..

From the lengths of the left and right arms of lever G, Figs. 199 and 201, it is obvious that the movement of pawl 13 will always be much less than the movement of pawl 21. It will also be quite clear that if all the distances between the holes on the cards, and between the outside holes and the gap between each pair of cards, were exactly the same, one pushing pawl only would be necessary, and arranged to operate a uniformly-cut feed ratchet wheel. The movements of the feed ratchet wheel H are limited to the correct distances by the pawls 13 and 21, and by the aid of a leather-faced wooden brake 27 and spring 28, Fig. 202. A small projection on the feed-shaft bracket 73 is provided with a set-screw by means of which the tension on the spring 28 may be adjusted.

NEEDLES AND THREAD TAKE-UP MECHANISM.—A separate head is required for each row of lacing; side elevations of these heads are numbered 29 and front covers 29¹ in Figs. 200 and 201, while complete views of the fronts of three heads are illustrated in Fig. 202. All the heads for one machine are supported by the two planed surfaces 30 of the upper cross-rail 31, and the needle bar rock shaft 32 passes behind all as shown.

Fulcrumed loosely on the shaft 34, Figs. 202, 209, and 210, is one end of a

lever 33; its opposite and free end carries an anti-friction roller 35, which runs in the groove of the box cam A. A connecting-rod 36 joins the free end of lever 33 to the crank 37 on the end of the needle bar rock shaft 32; hence, as the main shaft D revolves, the undulating outline of the positive cam A will impart a diverse series of oscillations to the needle bar rock shaft 32 and to all parts which are connected to it. In general, it will be gathered from the parts illustrated that as the anti-friction roller 35 moves downwards towards the centre of its disc 38, Figs. 209 and 210, the connecting-rod 36 will fall and cause the needle bar rock shaft 32 to move clockwise in Figs. 209, 210, and 201, and counter-clockwise in Fig. 200. In

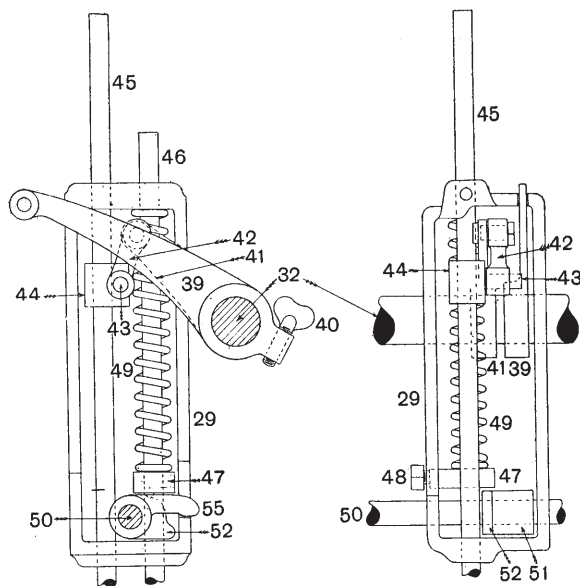

FIG. 206.

FIG. 207.

all cases, however, all subsequent attachments to the needle bar rock shaft 32 move upwards when the anti-friction roller 35 moves downwards. Conversely, when the roller 35 moves upwards towards the periphery of its disc 38, the connecting-rod 36 rises and all parts in the head 29 fall. No further explanation of these parts is desirable at present, since the actual movements will be better explained in conjunction with the movements of the shuttle. It is necessary, however, to

examine the connections between the needle bar rock shaft 32 and the various parts which are partially or wholly enclosed in the head 29. For this purpose Figs. 206 and 207 have been prepared; the former is a side elevation of the head, and the latter is a front elevation of the same—in both figures the front cover 29¹, Fig. 202, has been omitted.

On the needle bar rock shaft 32, and immediately behind each head, is fixed a thread take-up lever 39 by means of a wing-bolt 40, so that each take-up lever may be adjusted independently of any other to suit the degree of movement required at the extreme end of the lever. The lacing twine 90 passes through the hole in the end of the take-up lever 39, as exemplified in Figs. 200, 201, 202, 209, and 210. Each lever 39 moves in

opposite directions to, and reciprocally with, the crank 37 in the above five figures. Fixed near to each take-up lever 39, also on the needle bar rock shaft 32, by a set-screw, is a needle bar rock shaft crank 41, Figs. 206 and 207. Attached to the end of crank 41 is a link 42; the lower end of this link encircles a pin 43 which projects from the side of the collar 44. The latter is fixed by two set-screws to the needle bar 45. It will thus be seen that, as the needle bar rock shaft 32 oscillates, each needle bar 45 will rise and fall in unison with the similar movements of its companion thread take-up lever 39.

The presser foot bar 46 is immediately behind the needle bar 45; to the former, and near the bottom of the head 29, is fixed the bracket 47 by the set-screw 48. Between this bracket and the upper shell of the head 29 is a spiral spring 49 which encircles the presser foot bar 46. The presser bar rod 50 extends from the frame W, Fig. 202, through all the heads 29 as shown, while inside each head is a combined collar 51 and cam 52, Figs. 206 and 207, secured to the rod 50. Rod and cams are operated by the handle 53, Fig. 202. Thus, when the handle 53, Figs. 201 and 202,

is pressed downwards, the cam 52, Figs. 206 and 207, rotates slightly and raises the bracket 47, compresses the spiral spring 49, and a recess in the cam serves to hold the bracket 47 and the presser foot bar up with the presser foot 54 clear of the cards 26. Immediately, however, the handle 53 is raised, the cam 52 is lowered until the projecting piece 55 comes into contact with the bottom of the slot in the back shell of 29; while the cam 52 is being thus rotated, the pressure of the spiral spring 49 on the bracket 47 forces the latter and the presser foot downwards until the presser foot 54 reaches the card 26.

Attached to each presser foot 54, Figs. 200, 201, 202, 209, and 210, by a small set-screw, is a curved card wire guide 56. These card guides ensure that the cards shall be guided safely under each presser foot 54.

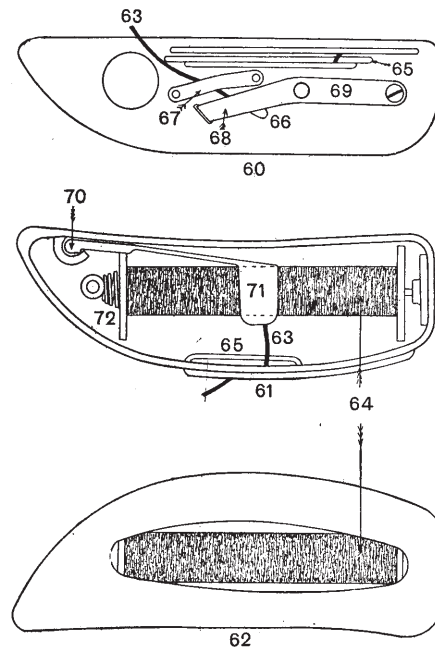

FIG. 208.

The travel of the shuttle carrier is constant so far as distance is concerned, and the distance between the carrier when it is vertical and the presser foot 54 must also be constant, no matter what set of feed-wheels are in use, in order to preserve the correct relation between the needles and the shuttles. It has already been mentioned that there is a slight difference between the diameters of the various sets of feed-wheels J and J¹, and hence it is necessary to provide means for raising and lowering the set without interfering with the mechanism which governs the movements of the shuttle carriers.

All the feed-wheels J and J¹, for one set, are, as previously mentioned, on the feed-wheel shaft S, Fig. 202, and the oscillating shuttle carrier also works upon this shaft as a centre, or rather as an approximate centre. The feed-wheel shaft S is supported by two brackets 73, one on frame W and the other on frame W¹, Figs. 200 and 202. These brackets 73 can be raised or lowered, within the required limits, by the milled-head screws 74; and when the two brackets and the shaft S have been adjusted correctly to place the feed-wheels J and J¹ at

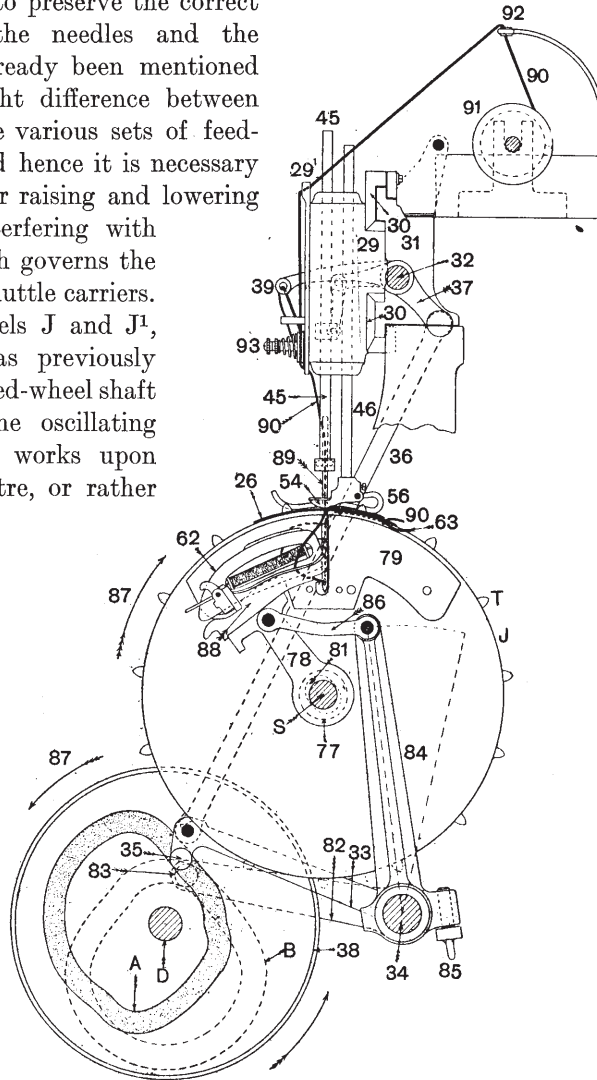

FIG. 210.

their correct height with respect to the shuttle carriers and needles, the brackets 73 are securely fixed to the frames W and W¹ by set-screws.

Secured to one of the main cross-rails 75, Figs. 200, 201, and 202,

are two, three, or more upright brackets 76, shown only in Fig. 202. The boss near the upper end of each of these brackets is bored out to receive the projecting boss 77 of the vibrating lever 78, while the bracket 76 is prolonged above the boss to provide supports for the shuttle face-plate 79—seen best in Figs. 209 and 210—and for the card lifters 57, Fig. 201. It is, of course, understood that the brackets 76 are capable of being slid along the planed bearings of the cross-rail 75 and fixed at any place by the hand-screws 80. The brackets and the shuttle carriers can thus be placed in their correct positions with regard to the rows of lacing, and the heads 29 can be moved in a similar way along the planed surfaces 30, and fixed by similar hand-screws not shown in the drawings but clearly visible above the heads 29 in Figs. 197 and 198.

Although the boss 77, Figs. 209 and 210, of the vibrating lever 78 is turned down to fit the hole in the boss of bracket 76, the hole 81 in the boss 77 is not circular, but is lengthened into a kind of ellipse, as shown. Hence the boss of bracket 76 is capable of keeping the boss 77 of the vibrating lever 78 in one fixed horizontal frame, while the feed-wheel shaft S can be raised or lowered through the necessary distance in virtue of the elliptical hole 81.

The shuttle carrier is operated as follows from the cam B, Figs. 200, 209, and 210. A lever 82 is fixed to the shaft 34, and an anti-friction roller 83 fits neatly into the groove of the positive cam B as shown. Along the shaft 34, and at the proper intervals, appear a number of shuttle rock-shaft levers 84, each of which is secured to the shaft 34 by the hand-screws 85, shown only in Figs. 209 and 210. The upper end of each of these levers 84 is joined to the corresponding upper end of vibrating lever 78 by a link 86. Hence it is evident that, as the parts revolve in the direction of the arrows 87, the recessed cam B will cause the levers 82 and 84 to oscillate, and will cause the latter to move through the angle enclosed by the dotted lines in Fig. 210. In doing so, the links 86 and the vibrating levers 78 will be moved to right and left alternately. The shuttle carrier 88 is fixed to the upper part of the vibrating lever 78; consequently, the shuttle is carried twice between the two extremes for each revolution of the cam B and the main shaft D.

Fig. 209 illustrates the back position of the shuttle and shuttle carrier, and at this time the needle 89, which is fixed to the needle bar 45 in the usual way, is down as illustrated. The upper lacing twine 90, from the bobbin 91, is first passed through the eye 92 of the upper guide, then through the upper eye in the front head cover 29¹, behind the guide pin and between the plates of the tension device 93, Fig. 202, up again and through the eye of the thread take-up lever 39, then down and through an eye near the bottom of the front cover 29¹, and through the eye in the

needle bar stud 94, and finally through the eye of the needle 89. The eye of the needle takes the lacing twine to the position shown in Fig. 209, and here two lengths of twine extend from the eye of the needle to the cards; one length is shown in dotted lines behind the needle, while the other length is shown solid in front of the needle. At the particular time indicated in Fig. 209 these two lengths of twine are comparatively straight and taut; but it is obvious that a gap must be made between the outer or solid-marked length of lacing twine and the needle 89 in order that the tip of the shuttle 62 may enter between the two lengths, and so enable the upper lacing twine to be locked on the underside of the card by the spool twine 63 when the needle 89 rises to its highest point.

As already mentioned, the needle is controlled by the positive cam A, and it will be advisable to study the cam illustrated in Fig. 194 in conjunction with Figs. 209 and 210. When point 1 of the cam A is in touch with the anti-friction roller 35, the needle is up; at point 2 the needle is moving down, while between points 1 and 2 the shuttle reaches the back position—that shown in Fig. 209; at point 3 the needle is nearly in its lowest position. The needle moves down a little from this point, then rises slightly at point 4 to form the slack in the length marked solid in front of the needle, and immediately after this point the cam B causes the shuttle to commence its travel. From point 4 to point 5 the needle goes almost to its extreme low position to relieve the tension on the upper lacing twine, as the thick part of the shuttle is passing between the twine and the needle, and so requires a longer length to avoid unnecessary friction. At point 6 the needle is full down, and the shuttle has reached the other side. At point 7 the needle is rising from its lowest position, and when it is about $\frac{1}{2}$ in. up it is drawing the lacing twine over the back of the shuttle as illustrated in Fig. 210. Finally, at 8 the needle is approaching the highest position.

To supplement the above description, and also to enable the reader to gather a better idea of the relative movements of the needle and shuttle, we append in Table VIII. particulars of the times for one complete revolution of shaft D, starting at a marked position of the balance-wheel when the needle is about $\frac{3}{8}$ in. from its lowest position and the shuttle is in the back position.

TABLE VIII.

At 360°	the needle is about $\frac{3}{8}$ in. from the lowest position.
From 360° to 30°	the needle is rising a little, say $\frac{1}{8}$ in. to $\frac{3}{16}$ in., to form a loop on the lacing twine for the tip of the shuttle to enter.
At 30°	the needle commences to go down.
„ 80°	„ is full down.
„ 90°	„ commences to rise.

- At 180° the needle is nearly at the top.
 „ 225° „ after a slight pause commences to move upwards again.
 „ 240° „ reaches the highest position and almost immediately commences the return journey.
 From 240° to 360° the needle is moving downwards to the first point of observation.
 At 360° the shuttle commences to move from full back position.
 „ 30° the shuttle tip is entering the loop between the needle and the lacing twine.
 „ 90° the shuttle is midway in its travel.
 „ 120° the shuttle is at the front.
 „ 135° the lacing twine is slipping over the back of the shuttle.
 „ 210° the shuttle commences to move back.
 „ 330° the point of the shuttle is passing the plane of the needle.
 „ 345° the shuttle is full back.
 „ 360° first point of observation.

With respect to these degrees it should be stated that the feed ratchet wheel H commences to move at 195°.

It will be seen that the lacing twine 63 from the shuttle 62, Figs. 209 and 210, simply passes through the loop formed by the upper lacing twine 90; that when the needle is above the card the latter is taken forward by the feed-wheels J and J¹, and the shuttle reaches the back position. The lacing twine 63 under the card is shown in dotted lines, and it extends to the spool in the shuttle. After the shuttle and twine 63 have passed through the loop, the upper lacing twine 90 is drawn tight by the combined action of the needle 89 and the thread take-up lever 39, and hence the spool twine 63 prevents the loop of the upper twine 90 from being carried upwards beyond the underside of the card 26. When the shuttle is moved to the back position, and the card has been moved through one of the divisions, the lacing twine 63 is naturally again on the right, as illustrated in Fig. 209, and ready again to move forward at the proper time to intercept the upward moving loop of the upper lacing twine 90.

It will be understood that the thread take-up lever 39 plays an important part in the regulation of the tension on the lacing twine. It will also be seen that, since the thread take-up lever 39 and the needle bar lever 41, Fig. 206, move in unison with the needle bar rock shaft 32, the movements of the needle and the thread take-up lever will practically coincide, although the latter naturally moves through a greater distance than the former.

The operator sits in front of the machine, Fig. 202, with a pile of cut and numbered cards on the table 95, and, when all is ready for starting, she presses down the back part of treadle K, on shaft L, and this movement will clearly cause the lever 96, also fulcrumed on shaft L, to pull down the chain 97¹; the upper part of this chain 97¹ runs in the groove of a pulley 97, while the extreme end of the chain is attached to a stud in the belt fork shipper bracket 98¹. The belt fork 99 being fixed to the outer end of the sliding bar 98 of shipper bracket 98¹, it follows that the belt fork