

***American National Standard
Voluntary Industry Performance Standards
for Pressure and Velocity
of Centerfire Rifle Ammunition
for the Use of Commercial Manufacturers***

American National Standards Institute

Headquarters

11 West 42nd Street, 13th Floor

New York, NY 10036

Tel: 212 642-4900 Fax: 212 398-0023

**American National Standard
Voluntary Industry Performance Standards
for Pressure and Velocity
of Centerfire Rifle Ammunition
for the Use of Commercial Manufacturers**

Sponsor

Sporting Arms and Ammunition Manufacturers' Institute, Inc.

Members

**Beretta USA Corporation
Broadsword Group LLC
Browning Arms Company
CCI/Speer Ammunition
Colt's Manufacturing Company LLC
COR-BON/Glaser LLC
Federal Cartridge Company
FIOCCHI of America, Inc.
Glock
Hodgdon Powder Company
Hornady Manufacturing Company
Kahr Arms**

**Marlin Firearms Company
North American Arms, Inc.
O.F. Mossberg & Sons, Inc.
Olin Corporation/Winchester Division
Remington Arms Company, LLC
SIG SAUER, Inc.
Smith & Wesson Holding Corp.
St. Marks Powder, Inc.
Sturm, Ruger & Co., Inc.
Taurus Holdings, Inc.
Weatherby, Inc.**

Associate Members:

**Alliant Powder
Nosler, Inc
Ruag Ammotech USA, Inc.
Savage Arms, Inc.**

Supporting Members:

**Advanced Tactical Armament Concepts, LLC
Barnes Bullets, LLC
Black Hills Ammunition, Inc.
Doubletap Ammunition, Inc.
Kent Cartridge, America
Knight Rifles
LCT Pro Shop
One Shot, Inc.
ProGrade Ammo Group LLC
Southern Ballistic Research, LLC d/b/a SBR**

**Approved December 14, 2015
American National Standards Institute**

Abstract In the interests of safety and interchangeability, this Standard provides pressure and velocity performance and dimensional characteristics for centerfire rifle sporting ammunition. Included are procedures and equipment for determining these criteria.

American National Standard

Approval of an American National Standard requires verification by ANSI that the requirements for due process, consensus, and other criteria for approval have been met by the standards developer.

Consensus is established when, in the judgment of the ANSI Board of Standards Review, substantial agreement has been reached by directly and materially affected interests. Substantial agreement means much more than a simple majority, but not necessarily unanimity. Consensus requires that all views and objections be considered, and that a concerted effort be made toward their resolution.

The use of American National Standards is completely voluntary; their existence does not in any respect preclude anyone, whether he has approved the standards or not, from manufacturing, marketing, purchasing, or using products, processes, or procedures not conforming to the standards.

The American National Standards Institute does not develop standards and will in no circumstances give an interpretation of any American National Standard. Moreover, no person shall have the right or authority to issue an interpretation of an American National Standard in the name of the American National Standards Institute. Requests for interpretation should be addressed to the secretariat or sponsor whose name appears on the title page of this standard.

CAUTION NOTICE: This American National Standard may be revised or withdrawn at any time. The procedures of the American National Standards Institute require that action be taken to reaffirm, revise, or withdraw this standard no later than five years from the date of approval. Purchasers of American National Standards may receive current information of all standards by calling or writing the American National Standards Institute.

Published by

***Sporting Arms and Ammunition Manufacturers' Institute, Inc.
Flintlock Ridge Office Center
11 Mile Hill Road, Newtown, Connecticut 06470-2359***

Copyright © 2015 by
Sporting Arms and Ammunition Manufacturers' Institute, Inc.
All rights Reserved.

No part of this publication may be reproduced in any form,
in an electronic retrieval system or otherwise, without
the prior written permission of the publisher.

Printed in the United States of America

(This foreword is not part of the American National Standard Z299.4)

Foreword

The development of this voluntary industry performance standard was initiated under the auspices of the Sporting Arms and Ammunition Manufacturers' Institute, Inc. (SAAMI). A Products Standards Task Force was established by the Institute in 1975 and charged with the drafting of this and other standards with their subsequent periodic revisions.

The material presented provides the commercial manufacturer of factory-loaded ammunition with pressure and velocity performance and dimensional characteristics. Included are procedures and equipment for determining these criteria. For the purpose of this standard a commercial manufacturer is defined as one who produces ammunition by fabricating component parts from raw materials as opposed to remanufacture with parts originally made by others.

This standard for Centerfire Rifle Sporting Ammunition was first published in 1979 and periodically updated until this revision in 2015. Changes in the standard with each revision include minor adjustments of velocities, the addition of new load offerings, and updating of recommended equipment sources and the latest procedures for reporting reference ammunition assessments.

Suggestions for improvement of this standard will be welcome. They should be sent to: The Sporting Arms and Ammunition Manufacturers' Institute, Inc., Flintlock Ridge Office Center, 11 Mile Hill Road, Newtown, Connecticut 06470-2359.

Consensus for this standard was achieved by use of the Canvass Method.

The following individuals and organizations recognized as having an interest in the standardization of safety requirements for factory-loaded sporting ammunition were contacted prior to the approval of this standard. Inclusion in this list does not necessarily imply that the individual or organization concurred with the submittal of the standard to ANSI:

Aberdeen Proving Grounds – P. Donahue
Association of Firearm and Toolmark Examiners – L. Haag
Association of Firearm and Toolmark Examiners – J. Hamby, M.A.
Boone Ballistics, LLC – B. Boone
BPI Outdoors/Bergara Barrel and Custom Rifle Division – M. Hendricks
Bureau of Alcohol, Tobacco, Firearms and Explosives – E. Griffith
Department of Homeland Security; National Armory – L. Johnson
Federal Bureau of Investigation – A. S. Patterson
Federal Law Enforcement Training Center (FLETC) – C. Nester, Jr
Forensic Ammunition Service – G. Kass
H.P. White Laboratory – W. Mason
H-S Precision, Inc – T. Houghton
Independent Author, Editor and Firearms Manufacturer - R. Cofield
Independent Expert – K. Kees
Manson Precision Reamers; Division of Loon Lake Precision – D. Manson
Massachusetts Institute of Firearms Technology – C. Hildebrandt
National Institute of Standards & Technology – K. Rice
Natural Resources – Canada – R. Bowes
PCB Piezotronics – R. Metz
Royal Canadian Mounted Police – R. Poaps
Western Powders – D. Luhr

TABLE OF CONTENTS

<u>SECTION I – CHARACTERISTICS</u>	<u>PAGE</u>
Cartridges and Chambers	
Full and Abbreviated Names	1
Velocity & Pressure	
Velocity Data Interpretation	5
Factors Affecting Pressure Measurements.....	6
Explanation of Pressure Terminology	8
Explanation of Pressure Measuring Systems	10
Velocity & Pressure Data – Crusher	11
Velocity & Pressure Data – Transducer.....	23
Bullet Type Abbreviations.....	35
Primer	
Primers and Primer Pockets	36
Cartridge and Chamber Drawings	
6 x 45mm	37
6mm Remington.....	38
6.5 Creedmoor.....	39
6.5 Grendel.....	40
6.5 x 55 Swedish.....	41
6.8mm Remington SPC	42
7mm Mauser (7x57).....	43
7mm Remington Magnum	44
7mm Remington Short Action Ultra Magnum	45
7mm Remington Ultra Magnum	46
7mm Shooting Times Westerner	47
7mm Weatherby Magnum	48
7mm Winchester Short Magnum.....	49
7mm-08 Remington	50
7 x 64 Brenneke	51
7-30 Waters	52
7.62 x 39.....	53
8mm Mauser (8 x 57).....	54
8mm Remington Magnum	55
9.3 x 62.....	56
17 Hornet	57
17 Remington.....	58
17 Remington Fireball	59
204 Ruger.....	60
218 Bee	61
22 Hornet	62
22-250 Remington	63
220 Swift.....	64
221 Remington Fireball	65
222 Remington.....	66
222 Remington Magnum	67
223 Remington.....	68

223 Winchester Super Short Magnum	69
225 Winchester	70
243 Winchester	71
243 Winchester Super Short Magnum	72
25 Winchester Super Short Magnum	73
25-06 Remington	74
25-20 Winchester	75
25-35 Winchester	76
250 Savage	77
257 Roberts	78
257 Roberts +P	78
257 Weatherby Magnum	79
26 Nosler	80
260 Remington	81
264 Winchester Magnum	82
27 Nosler	83
270 Weatherby Magnum	84
270 Winchester	85
270 Winchester Short Magnum	86
28 Nosler	87
280 Ackley Improved	88
280 Remington	89
284 Winchester	90
30 Carbine	91
30 Nosler	92
30 Remington AR	93
30 Thompson Center	94
30-06 Springfield	95
30-30 Winchester	96
30-40 Krag	97
300 AAC Blackout	98
300 Holland & Holland Magnum	99
300 Remington Short Action Ultra Magnum	100
300 Remington Ultra Magnum	101
300 Ruger Compact Magnum	102
300 Savage	103
300 Weatherby Magnum	104
300 Winchester Magnum	105
300 Winchester Short Magnum	106
303 British	107
307 Winchester	108
308 Marlin Express	109
308 Winchester	110
32 Winchester Special	111
32-20 Winchester	112
325 Winchester Short Magnum	113
33 Nosler	114
338 Federal	115
338 Lapua Magnum	116

338 Marlin Express	117
338 Remington Ultra Magnum	118
338 Ruger Compact Magnum	119
338 Winchester Magnum	120
340 Weatherby Magnum	121
348 Winchester	122
35 Nosler	123
35 Remington	124
35 Whelen	125
350 Remington Magnum	126
356 Winchester	127
358 Winchester	128
36 Nosler	129
370 Sako Magnum	130
375 Holland & Holland Magnum	131
375 Remington Ultra Magnum	132
375 Ruger	133
375 Winchester	134
376 Steyr	135
38-40 Winchester	136
38-55 Winchester	137
405 Winchester	138
416 Remington Magnum	139
416 Rigby	140
416 Ruger	141
416 Weatherby Magnum	142
44 Remington Magnum	143
44-40 Winchester	144
444 Marlin	145
45-70 Government	146
450 Bushmaster	147
450 Marlin	148
457 Wild West Guns	149
458 Lott	150
458 Winchester Magnum	151
470 Nitro Express	152
475 Turnbull	153
500 Nitro Express 3"	154

Miscellaneous

Dummy Cartridge – Gun Functioning	155
Dummy Cartridge – Display	156
Tolerance – Bullet Weight	157

SECTION II - PROCEDURES

Velocity and Pressure

Procedure: Velocity & Copper Crusher Pressure Testing	158
Velocity & Pressure Barrels: Qualification	164
Velocity & Pressure Barrels: Mounting in Receivers	165

Procedure: Use of Piston Hole Gauges	166
Procedure: Piezoelectric Transducer Calibration.....	167
Transducer Calibration: Increments and Ranges	170
Transducer Calibration: Equipment Interconnection.....	175
Transducer Calibration: Least Square Line Computation	176
Firing Test: Equipment Interconnection	178
Reference Ammunition	
Use	180
Secondary Reference Ammunition	182
New Lots	183
Identification Protocol	186
Periodic Assessment	187

SECTION III – EQUIPMENT

Equipment: Velocity & Copper Crusher Pressure Testing	191
Equipment: Velocity & Conformal Piezoelectric Pressure Testing	193
Copper Crushers	
Usage of Crusher Cylinders in Pressure Testing	195
Sample Tarage Tables.....	196
Crusher Cylinders: Dimensions	198
Gas Checks	
Equipment: 0.146” and 0.206” Gas Checks.....	200
Equipment: Gas Check Tools – Seating and Knockout.....	201
Pistons & Piston Holes	
Equipment: Pistons and Piston Holes	202
Equipment: Piston Hole Gauges	209
Piston Oil – Piston and Gas Check	211
Headspace Gauges	
Headspace Gauges	212
Reference Ammunition	
Equipment: Reference Ammunition Supply	221
Equipment: Reference Ammunition Order Procedure.....	222
Miscellaneous	
Supplier Contact Information	223
Equipment: Schematic Layout of Velocity Screens	224
Equipment: Universal Receiver Collar and Test Barrel	225
Universal Receiver Test Barrel: Installation of Pressure Transducers	227
Equipment: Transducer Calibration Fixture Plug with O-ring Seal	229
Transducer Location Criteria	230
Standard V&P Test Barrels - General	
Procedures for Dimensioning Chambers	231
Procedures for Measuring Barrel Length.....	232
Standard Velocity and Pressure Test Barrels	
6 x 45mm	233
6mm Remington.....	234
6.5 Creedmoor.....	235
6.5 Grendel.....	236
6.5 x 55 Swedish.....	237

6.8mm Remington SPC	238
7mm Mauser (7x57).....	239
7mm Remington Magnum	240
7mm Remington Short Action Ultra Magnum	241
7mm Remington Ultra Magnum	242
7mm Shooting Times Westerner	243
7mm Weatherby Magnum	244
7mm Winchester Short Magnum	245
7mm-08 Remington	246
7 x 64 Brenneke	247
7-30 Waters	248
7.62 x 39.....	249
8mm Mauser (8 x 57).....	250
8mm Remington Magnum	251
9.3 x 62.....	252
17 Hornet	253
17 Remington.....	254
17 Remington Fireball	255
204 Ruger.....	256
218 Bee	257
22 Hornet	258
22-250 Remington	259
220 Swift.....	260
221 Remington Fireball	261
222 Remington.....	262
222 Remington Magnum	263
223 Remington.....	264
223 Winchester Super Short Magnum	265
225 Winchester	266
243 Winchester	267
243 Winchester Super Short Magnum	268
25 Winchester Super Short Magnum	269
25-06 Remington	270
25-20 Winchester	271
25-35 Winchester	272
250 Savage	273
257 Roberts	274
257 Roberts +P.....	274
257 Weatherby Magnum.....	275
26 Nosler	276
260 Remington.....	277
264 Winchester Magnum	278
27 Nosler	279
270 Weatherby Magnum.....	280
270 Winchester	281
270 Winchester Short Magnum	282
28 Nosler	283
280 Ackley Improved	284
280 Remington.....	285

284 Winchester	286
30 Carbine	287
30 Nosler	288
30 Remington AR	289
30 Thompson Center	290
30-06 Springfield	291
30-30 Winchester	292
30-40 Krag	293
300 AAC Blackout	294
300 Holland & Holland Magnum	295
300 Remington Short Action Ultra Magnum	296
300 Remington Ultra Magnum	297
300 Ruger Compact Magnum	298
300 Savage	299
300 Weatherby Magnum	300
300 Winchester Magnum	301
300 Winchester Short Magnum	302
303 British	303
307 Winchester	304
308 Marlin Express	305
308 Winchester	306
32 Winchester Special	307
32-20 Winchester	308
325 Winchester Short Magnum	309
33 Nosler	310
338 Federal	311
338 Lapua Magnum	312
338 Marlin Express	313
338 Remington Ultra Magnum	314
338 Ruger Compact Magnum	315
338 Winchester Magnum	316
340 Weatherby Magnum	317
348 Winchester	318
35 Nosler	319
35 Remington	320
35 Whelen	321
350 Remington Magnum	322
356 Winchester	323
358 Winchester	324
36 Nosler	325
370 Sako Magnum	326
375 Holland & Holland Magnum	327
375 Remington Ultra Magnum	328
375 Ruger	329
375 Winchester	330
376 Steyr	331
38-40 Winchester	332
38-55 Winchester	333
405 Winchester	334

416 Remington Magnum	335
416 Rigby.....	336
416 Ruger.....	337
416 Weatherby Magnum.....	338
44 Remington Magnum	339
44-40 Winchester	340
444 Marlin.....	341
45-70 Government	342
450 Bushmaster.....	343
450 Marlin.....	344
457 Wild West Guns	345
458 Lott.....	346
458 Winchester Magnum.....	347
470 Nitro Express	348
475 Turnbull.....	349
500 Nitro Express 3”	350

SECTION IV – DEFINITIVE PROOF LOADS

Definition and Purpose	351
Proof Pressure Data Interpretation.....	352
Proof Pressure Data – Crusher	353
Proof Pressure Data – Transducer.....	357
Proof Load Supply	361
Proof Cartridge Identification.....	362
Definitive Proof Package Identification.....	363

CARTRIDGES AND CHAMBERS FULL AND ABBREVIATED NAMES

The following list presents the recommended full names and abbreviated names of the centerfire rifle cartridges and chambers currently supplied for various types of firearms.

These full or abbreviated names should be used on cartridge headstamps and on firearm markings to properly identify the caliber.

ORDER OF LISTING

Lists of centerfire rifle cartridges are arranged according to the following rules:

- 1) All Metric cartridges
 - a) First in ascending numerical order of approximate caliber designation,
 - b) Then in alphabetical order.

- 2) Followed by American cartridges
 - a) First in ascending numerical order of approximate caliber designation,
 - b) Then alphabetical order.

- 3) Within each of the above groups, cartridges are arranged in order of:
 - a) 2-digit numbers,
 - b) 2-digit numbers and a hyphen followed by more numbers,
 - c) 3-digit numbers.

For lists that present both cartridge name and several bullet weights, list in ascending numerical order of bullet weights.

Active Cartridges and Chambers

<u>Full Name</u>	<u>Abbreviated Name</u>
6 x 45mm	6 x 45mm
6mm Remington.....	6mm Rem
6.5 Creedmoor.....	6.5 Creedmoor
6.5 Grendel.....	6.5 Gren
6.5 x 55 Swedish	6.5x55
6.8mm Remington SPC	6.8mm Rem SPC
7mm Mauser (7x57).....	7mm (7x57)
7mm Remington Magnum	7mm Rem Mag
7mm Remington Short Action Ultra Magnum	7mm Rem SA Ultra Mag
7mm Remington Ultra Magnum	7mm Rem Ultra Mag
7mm Shooting Times Westerner	7mm STW
7mm Weatherby Magnum	7mm Wby Mag
7mm Winchester Short Magnum	7mm WSM
7mm-08 Remington	7mm-08 Rem
7 x 64 Brenneke	7x64
7-30 Waters.....	7-30 Waters
7.62 x 39.....	7.62x39

8mm Mauser (8x57).....	8mm (8x57)
8mm Remington Magnum	8mm Rem Mag
9.3 x 62.....	9.3 x 62
17 Hornet	17 Hornet
17 Remington.....	17 Rem
17 Remington Fireball	17 Rem Fireball
204 Ruger.....	204 Ruger
218 Bee	218 Bee
22 Hornet	22 Hornet
22-250 Remington	22-250 Rem
220 Swift.....	220 Swift
221 Remington Fireball	221 Rem Fireball
222 Remington.....	222 Rem
222 Remington Magnum	222 Rem Mag
223 Remington.....	223 Rem
223 Winchester Super Short Magnum.....	223 WSSM
225 Winchester	225 Win
243 Winchester	243 Win
243 Winchester Super Short Magnum.....	243 WSSM
25 Winchester Super Short Magnum.....	25 WSSM
25-06 Remington	25-06 Rem
25-20 Winchester	25-20 Win
25-35 Winchester	25-35 Win
250 Savage	250 Sav
257 Roberts	257 Rob
257 Roberts +P.....	257 Rob +P*
257 Weatherby Magnum.....	257 Wby Mag
26 Nosler.....	26 Nosler
260 Remington.....	260 Rem
264 Winchester Magnum.....	264 Win Mag
27 Nosler.....	27 Nosler
270 Weatherby Magnum.....	270 Wby Mag
270 Winchester	270 Win
270 Winchester Short Magnum	270 WSM
28 Nosler.....	28 Nosler
280 Ackley Improved	280 Ack Imp
280 Remington.....	280 Rem
284 Winchester	284 Win
30 Carbine.....	30 Carb
30 Nosler.....	30 Nosler

* This ammunition is loaded to a higher pressure, as indicated by the +P marking on the case headstamp, to achieve higher velocity. Use only in firearms especially designed for this cartridge and so recommended by the manufacturer.

30 Remington AR	30 Rem AR
30 Thompson Center	30 TC
30-06 Springfield	30-06 Sprg
30-30 Winchester	30-30 Win
30-40 Krag	30-40 Krag
300 AAC Blackout.....	300 Blk
300 Holland &Holland Magnum	300 H&H Mag
300 Remington Short Action Ultra Magnum.....	300 Rem SA Ultra Mag
300 Remington Ultra Magnum	300 Rem Ultra Mag
300 Ruger Compact Magnum.....	300 RCM
300 Savage	300 Sav
300 Weatherby Magnum.....	300 Wby Mag
300 Winchester Magnum	300 Win Mag
300 Winchester Short Magnum	300 WSM
303 British.....	303 Brit
307 Winchester	307 Win
308 Marlin Express	308 Mar Exp
308 Winchester	308 Win
32 Winchester Special.....	32 Win Spl
32-20 Winchester	32-20 Win
325 Winchester Short Magnum	325 WSM
33 Nosler.....	33 Nosler
338 Federal.....	338 Fed
338 Lapua Magnum	338 Lapua Mag
338 Marlin Express	338 M E
338 Remington Ultra Magnum	338 Rem Ultra Mag
338 Ruger Compact Magnum.....	338 RCM
338 Winchester Magnum.....	338 Win Mag
340 Weatherby Magnum.....	340 Wby Mag
348 Winchester	348 Win
35 Nosler.....	35 Nosler
35 Remington.....	35 Rem
35 Whelen	35 Whelen
350 Remington Magnum	350 Rem Mag
356 Winchester	356 Win
358 Winchester	358 Win
36 Nosler.....	36 Nosler
370 Sako Magnum	370 Sako Mag
375 Holland & Holland Magnum	375 H&H Mag
375 Remington Ultra Magnum	375 Rem Ultra Mag
375 Ruger.....	375 Ruger
375 Winchester	375 Win
376 Steyr	376 Steyr

38-40 Winchester	38-40 Win
38-55 Winchester	38-55 Win
405 Winchester	405 Win
416 Remington Magnum	416 Rem Mag
416 Rigby.....	416 Rigby
416 Ruger.....	416 Ruger
416 Weatherby Magnum.....	416 Wby Mag
44 Remington Magnum	44 Rem Mag
44-40 Winchester	44-40 Win
444 Marlin.....	444 Mar
45-70 Government	45-70 Govt
450 Bushmaster.....	450 Bushmaster
450 Marlin.....	450 Marlin
457 Wild West Guns.....	45 WWG
458 Lott.....	458 Lott
458 Winchester Magnum.....	458 Win Mag
470 Nitro Express	470 NE
475 Turnbull.....	475 Turnbull
500 Nitro Express 3”.....	500 NE 3”

VELOCITY DATA INTERPRETATION

Velocity recommendations are stated on the basis of a nominal lot mean velocity as measured using equipment in accordance with the requirements of Section III and the procedures detailed in Section II. Due to the fact that sporting firearms for general distribution are typically manufactured to dimensional tolerances greater than those specified for test barrels, there should be no expectation that these velocities can be duplicated from any test utilizing firearms. This situation is further confounded by discrepancies in barrel length. Furthermore, once ammunition has left the control of the manufacturer, storage conditions outside those recommended by the manufacturer may cause variations in the velocity as measured using test equipment and procedures which conform to the requirements of this Standard.

The values presented on pages 11 through 34 are recommended values for the use of ammunition producers at the time of manufacture. It is the responsibility of the manufacturer to establish sample sizes, sampling frequencies, and tolerances to ensure the performance of the ammunition obtained by the ultimate user meets all applicable safety and functional standards. Of particular importance in establishing velocity tolerances is the understanding that velocities significantly higher than the nominal lot mean can cause actual maximum range performance to exceed expected values.

Ammunition tested subsequent to manufacture using equipment and procedures conforming to these guidelines can be expected to produce velocities within a tolerance of ± 90 fps of the tabulated values.

FACTORS AFFECTING PRESSURE MEASUREMENTS

Two principal methods of measuring centerfire rifle pressures are recognized: the copper crusher method and the piezoelectric transducer method. One or the other may be used or they may be used simultaneously.

There are three principal factors affecting pressure measurements. These are instrumentation, ammunition and procedure. The following lists present the items in each category that may cause difficulties in testing carried out with the two methods.

I. FACTORS IN COPPER CRUSHER TESTING

INSTRUMENTATION

1. Condition of test barrel (whether minimum or maximum bore, chamber size and headspace, amount of erosion at throat and bore).
2. Diameter of piston and piston hole.
3. Fit of piston in piston hole.
4. Location of piston hole.
5. Tightness of barrel mounting in Universal Receiver, if used.
6. Shape, size and protrusion of firing pin beyond breech face.
7. Force of firing pin blow.
8. Size, material and characteristics of the pressure-sensitive element of the gauge (copper crusher cylinders).
9. Type, size and condition of gas check.
10. Type of piston and gas check lubricant.
11. Quality and tolerance of piston hole gauges and headspace gauges.
12. Quality of crusher measuring instrument.

AMMUNITION

1. Condition of cartridge.
2. Position of powder in cartridge case.
3. Temperature of ammunition.

PROCEDURE

1. Failure to mount pressure barrel properly in Universal Receiver or other test action to assure minimum headspace.
2. Failure to rotate cartridge and close breech carefully to assure proper powder positioning.
3. Failure to wipe piston ends, crusher and setscrew face to remove excess oil.
4. Failure to center crusher cylinder on piston and properly adjust setscrew.
5. Failure to fire warming shots.
6. Overheating barrel by excessive rate of fire.
7. Failure to clean bore and control metal fouling.
8. Failure to clear barrel of brass disk blanked from the case wall and gas check from previous shot.

II. FACTORS IN PIEZOELECTRIC TRANSDUCER TESTING

INSTRUMENTATION

1. Condition of test barrel (whether minimum or maximum bore, chamber size and headspace, amount of erosion at throat and bore).
2. Fit of transducer in barrel.
3. Location of transducer.
4. Tightness of barrel mounting in Universal Receiver, if used.
5. Shape, size and protrusion of firing pin beyond breech face.
6. Force of firing pin blow.
7. Characteristics of the transducer.
8. Quality of the transducer.
9. Quality of the read-out system.

AMMUNITION

1. Condition of cartridge.
2. Position of powder in cartridge case.
3. Temperature of ammunition.

PROCEDURE

1. Failure to mount pressure barrel properly in Universal Receiver or other test action to assure minimum headspace.
2. Failure to rotate cartridge and close breech carefully to assure proper powder positioning.
3. Failure to fire warming shots.
4. Overheating barrel by excessive rate of fire.
5. Failure to clean bore and control metal fouling.
6. Failure to protect transducer against contamination, such as oil or water.
7. Transducer calibration.
8. Read-out system calibration.

EXPLANATION OF PRESSURE TERMINOLOGY

The SAAMI Pressure data outlined in this section is based on a Maximum Average Pressure (MAP) for each cartridge and a Coefficient of Variation of 4%. The Coefficient of Variation (CV) of 4% was based on the CV that exists for the 50,000 psi pressure level and is calculated by dividing the population standard deviation ($\sigma = 2,000$ psi) by the Maximum Average Pressure (MAP = 50,000 psi) which equals 0.04 (4%). All other pressure terminology is derived directly from these two terms.

SAAMI recognizes two pressure-measuring systems. The preferred system is the piezoelectric transducer system with the transducer flush-mounted in the chamber of the test barrel. Pressure developed by the burning propellant exerts force on the transducer through the cartridge case wall causing the transducer to deflect, creating a measurable electric charge. Pressures measured with this system are expressed in units of "pounds per square inch" (abbreviated psi).

The second, older system employs a copper crusher cylinder which is compressed by a piston fitted to a piston hole into the chamber of the test barrel. Pressure generated by the burning propellant acts on the base of the piston forcing the piston to move, thereby permanently compressing the copper cylinder. Pressures measured by this system are expressed in "Copper Units of Pressure (abbreviated as CUP).

Throughout the following text the pressure is expressed in terms of "pounds per square inch" (psi) however, it should be understood that the same procedures apply to pressures expressed in "Copper Units of Pressure" (CUP).

Maximum Average Pressure - is the recommended maximum pressure level for loading commercial sporting ammunition.

Standard Deviation (σ) - The Standard Deviation for each Maximum Average Pressure level is based on a Coefficient of Variation of 4%. This 4% Coefficient of Variation is maintained throughout the SAAMI pressure spectrum providing a realistic Standard Deviation for each pressure level. To obtain the Standard Deviation for a particular MAP, multiply the MAP by 0.04 (i.e., 50,000 psi x 0.04 = 2,000 psi).

Standard Error (σ_x) - The standard error is calculated by dividing the Standard Deviation (population S. D. = σ) by the square root of the sample size $\sigma_x = \sigma/\sqrt{n}$

Maximum Probable Lot Mean (MPLM) - The MPLM is calculated by adding two standard errors to the Maximum Average Pressure in order to assure there is a 97.5% probability that the Maximum Probable Lot Mean pressure is not exceeded. See Figure 1.

The SAAMI pressures are calculated based on a sample size of ten (10). The Maximum Probable Lot Mean represents the midpoint of the upper service pressure distribution. See Figure 1. For example, if the Maximum Average Pressure is 50,000 psi, the Maximum Probable Lot Mean (MPLM) is calculated as follows:

$$\text{MPLM} = \text{Maximum Average Pressure} + 2 \text{ standard errors}$$

$$\text{MPLM} = 50,000 \text{ psi} + [(50,000 \text{ psi} \times 0.04)/\sqrt{10}] \times 2$$

$$\text{MPLM} = 50,000 \text{ psi} + (633 \text{ psi} \times 2) = 50,000 \text{ psi} + 1266 \text{ psi} = 51,266 \text{ psi rounded to } 51,300 \text{ psi}$$

Maximum Probable Sample Mean (MPSM) - is the maximum expected average pressure that may be observed in the testing of product subsequent to its manufacture and is not intended for use as a loading control point. The Maximum Probable Sample Mean is positioned three (3) standard errors above the Maximum Probable Lot Mean i.e., $\text{MPLM} + 3 \sigma_{\bar{x}}$. See Figure 1. The Maximum Probable Sample Mean defined here is the value previously referred to in the ANSI/SAAMI Standards as the Maximum Product Average.

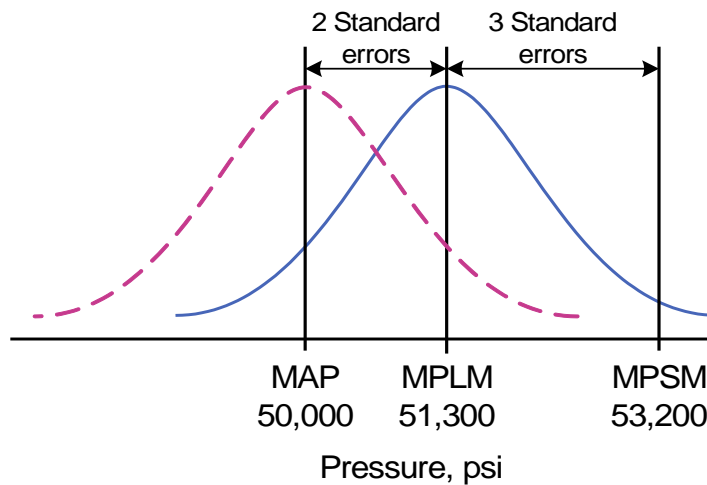

Figure 1

Maximum Extreme Variation - The maximum allowable sample E.V. (Extreme Variation or Range) is a statistic derived from the knowledge of the population Standard Deviation. Applying table figures from the Relative Range Tables (Biometrika Tables for Statisticians) we calculate the Maximum E.V. or Range as (population σ) x 5.16 (table constant for sample of 10 at 99.0% confidence level) i.e., $2,000 \text{ psi} \times 5.16 = 10,320 \text{ psi rounded down to } 10,300 \text{ psi}$.

EXPLANATION OF PRESSURE MEASURING SYSTEMS

The two SAAMI-recognized pressure-measuring systems for centerfire rifle cartridges are the copper crusher system and the piezoelectric transducer system.

A brief explanation of these two systems follows:

COPPER CRUSHER SYSTEM

This system employs a copper crusher cylinder that is compressed by a piston fitted to a piston hole into the chamber of the test barrel. The pressure developed by the gases from the burning propellant acts through the piston hole, allowing the gases to force the piston upward, and thereby permanently compressing the copper crusher cylinder. The Sporting Arms and Ammunition Manufacturers' Institute has adopted the pressure units designation of "Copper Units of Pressure" (abbreviated CUP) for this system. This designation applies only to values obtained using the particular crushers, target tables and methods outlined in this Standard.

PIEZOELECTRIC TRANSDUCER SYSTEM

This system employs a piezoelectric transducer flush mounted in the chamber of the test barrel. Pressure developed by the gases from the burning propellant exerts force on the transducer through the cartridge case wall causing the transducer to deflect, creating a measurable electric charge. This electrical charge is converted into a reading of pressure.

The Sporting Arms and Ammunition Manufacturers' Institute has adopted the pressure units designation of "pounds per square inch" (abbreviated psi) for this system. This designation applies to values obtained with transducers and methods as outlined in this Standard.

**VELOCITY AND PRESSURE:
 VELOCITY & PRESSURE DATA – CRUSHER**

Cartridge	Bullet Weight (gr.)	Velocity (fps) Nominal Mean Instrumental @ 15' Test Bbl.	Pressure Limits (CUP/100) ⁽¹⁾		
			Maximum Average Pressure (MAP)	Maximum Probable Lot Mean (MPLM)	Maximum Probable Sample Mean (MPSM)
6 x 45mm	80	2,500	CUP Pressures Not Established		
6mm Remington	75	3,400	520	533	553
	80	3,400			
	90	3,175			
	95	3,225			
	100	3,090			
6.5 Creedmoor	120	2,900	CUP Pressures Not Established		
	129	2,940	CUP Pressures Not Established		
	140	2,690	CUP Pressures Not Established		
6.5 Grendel	123	2,580	CUP Pressures Not Established		
6.5x55 Swedish	129	2,750	460	472	489
	140	2,550			
6.8mm Remington SPC		2,735	CUP Pressures Not Established		
	115	2,610	CUP Pressures Not Established		
		2,760	CUP Pressures Not Established		
7mm Mauser (7x57)	139	2,650	460	472	489
		2,820			
	145	2,680			
	154	2,600			
	160	2,500			
7mm Remington Magnum	175	2,420	520	533	553
	125	3,290			
	139	3,150			
		3,230			
	140	2,700			
		3,085			
	150	2,990			
		3,100			
	3,035				
	160-162	2,940			
	175	2,850			

⁽¹⁾ Based on sample size n=10.

**VELOCITY AND PRESSURE:
 VELOCITY AND PRESSURE DATA – CRUSHER (Cont'd)**

Cartridge	Bullet Weight (gr.)	Velocity (fps) Nominal Mean Instrumental @ 15' Test Bbl.	Pressure Limits (CUP/100) ⁽¹⁾		
			Maximum Average Pressure (MAP)	Maximum Probable Lot Mean (MPLM)	Maximum Probable Sample Mean (MPSM)
7mm Remington Short Action Ultra Magnum	140	3,165	CUP Pressures Not Established		
	150	3,095			
	160	2,950			
7mm Remington Ultra Magnum	140	3,415	CUP Pressures Not Established		
	150	3,315			
	160	3,190			
	175	3,015			
7mm Shooting Times Westerner	140	3,310	530	543	563
	150	3,280			
	160	3,250			
7mm Weatherby Magnum	140	3,165	CUP Pressures Not Established		
	175	2,840			
7mm Winchester Short Magnum	140	3,225	CUP Pressures Not Established		
	150	3,200			
	160	2,975			
7mm-08 Remington	120	2,990	520	533	553
	139	2,980			
	140	2,845			
7x64 Brenneke	140	2,950	505	518	537
	160	2,600			
7-30 Waters	120	2,700	400	410	425
7.62x39	123	2,350	500	513	532
8mm Mauser (8x57)	170	2,340	370	379	393
8mm Remington Magnum	185	3,065	540	554	574
	200	2,900			
	220	2,815			
9.3 x 62	286	2,360	CUP Pressures Not Established		
17 Hornet	15½	3,860	CUP Pressures Not Established		
	20	3,625			
17 Remington	20	4,250	520	533	553
	25	4,000			
17 Remington Fireball	20	3,970	CUP Pressures Not Established		
	25	3,850			

⁽¹⁾ Based on sample size $n=10$.

**VELOCITY AND PRESSURE:
 VELOCITY AND PRESSURE DATA – CRUSHER (Cont'd)**

Cartridge	Bullet Weight (gr.)	Velocity (fps) Nominal Mean Instrumental @ 15' Test Bbl.	Pressure Limits (CUP/100) ⁽¹⁾		
			Maximum Average Pressure (MAP)	Maximum Probable Lot Mean (MPLM)	Maximum Probable Sample Mean (MPSM)
204 Ruger	32	4,075	CUP Pressures Not Established		
	34	3,990			
	40	3,775			
	45	3,500			
218 Bee	46	2,725	400	410	425
22 Hornet	33	3,040	430	441	457
	34	2,985			
	35	3,040			
	45-46	2,655			
22-250 Remington	35	4,350	530	543	563
		4,450			
	40	3,975			
		4,125			
	45	4,000			
	50	3,800			
		4,000			
220 Swift	40	4,040	540	554	574
		4,170			
	50	3,840			
	55	3,650			
221 Remington Fireball	50	2,975	520	533	553
222 Remington	35	3,760	460	472	489
	40	3,370			
		3,570			
	50-52	3,110			
		3,345			
222 Remington Magnum	55	3,215	500	513	532

⁽¹⁾ Based on sample size $n=10$.

VELOCITY AND PRESSURE:
VELOCITY AND PRESSURE DATA – CRUSHER (Cont'd)

Cartridge	Bullet Weight (gr.)	Velocity (fps) Nominal Mean Instrumental @ 15' Test Bbl.	Pressure Limits (CUP/100) ⁽¹⁾		
			Maximum Average Pressure (MAP)	Maximum Probable Lot Mean (MPLM)	Maximum Probable Sample Mean (MPSM)
223 Remington	35	3,800 4,000	520	533	553
	40	3,650 3,770			
	42	3,450			
	45	3,550			
	50	3,410			
	53	3,305 3,465			
	55	3,050 3,215			
	60	3,080 3,200			
		3,000			
	62	3,080 3,240			
	64	3,000 3,070			
	69	2,985			
	75	2,775			
	77	2,670 2,785			
223 Winchester Super Short Magnum	55 64	3,850 3,600	CUP Pressures Not Established		
225 Winchester	55	3,540	500	513	532
243 Winchester	55	3,880	520	533	553
	58	3,730 3,925			
	75	3,325 3,580			
	80	3,325			
	85-87	3,300			
	90	3,110			
	95	3,050 3,175			
	100	2,950 3,050 3,080			

⁽¹⁾ Based on sample size $n=10$.

**VELOCITY AND PRESSURE:
 VELOCITY AND PRESSURE DATA – CRUSHER (Cont'd)**

Cartridge	Bullet Weight (gr.)	Velocity (fps) Nominal Mean Instrumental @ 15' Test Bbl.	Pressure Limits (CUP/100) ⁽¹⁾		
			Maximum Average Pressure (MAP)	Maximum Probable Lot Mean (MPLM)	Maximum Probable Sample Mean (MPSM)
243 Winchester Super Short Magnum	55	4,125	CUP Pressures Not Established		
	95	3,250			
	100	3,110			
25 Winchester Super Short Magnum	85	3,470	CUP Pressures Not Established		
	110	3,090			
	115	3,060			
	120	2,990			
25-06 Remington	85	3,510	530	543	563
	87	3,420			
	90	3,420			
	100	3,210			
	115	3,100			
	117	2,975			
	120	3,100			
25-20 Winchester	86	1,445	280	287	298
25-35 Winchester	117	2,210	370	379	393
250 Savage	87	3,010	450	461	478
	100	2,800			
257 Roberts	87	3,150	450	461	478
	100	2,880			
	117	2,630			
257 Roberts +P	100	2,980	500	513	532
	117	2,760			
		2,920			
257 Weatherby Magnum	87	3,845	535	549	569
	100	3,580			
	120	3,335			
26 Nosler	129	3,400	CUP Pressures Not Established		
260 Remington	120	2,880	CUP Pressures Not Established		
	140	2,725			
264 Winchester Magnum	100	3,300	540	554	574
	140	3,015			
27 Nosler	150	3,200	CUP Pressures Not Established		
270 Weatherby Magnum	100	3,745	535	549	569
	130	3,350			
	150	3,220			

⁽¹⁾ Based on sample size $n=10$.

**VELOCITY AND PRESSURE:
 VELOCITY AND PRESSURE DATA – CRUSHER (Cont'd)**

Cartridge	Bullet Weight (gr.)	Velocity (fps) Nominal Mean Instrumental @ 15' Test Bbl.	Pressure Limits (CUP/100) ⁽¹⁾		
			Maximum Average Pressure (MAP)	Maximum Probable Lot Mean (MPLM)	Maximum Probable Sample Mean (MPSM)
270 Winchester	100	3,300	520	533	553
	115	2,695			
		3,050			
	130	3,130			
		3,200			
	135	2,990			
	140	2,950			
		3,090			
		2,830			
		2,925			
	2,950				
	3,000				
	160	2,650			
270 Winchester Short Magnum	130	3,275	CUP Pressures Not Established		
	140	3,125			
	150	3,150			
28 Nosler	168	3,125	CUP Pressures Not Established		
280 Ackley Improved	140	3,260	CUP Pressures Not Established		
280 Remington	120	3,135	500	513	532
	139	3,100			
	140	2,985			
	150	2,875			
		2,975			
	165	2,800			
284 Winchester	125	3,125	540	554	574
	150	2,845			
30 Carbine ⁽²⁾	110	1,965	400	410	425
30 Nosler	210	2,950	CUP Pressures Not Established		
30 Remington AR	125	2,775	CUP Pressures Not Established		
30 Thompson Center	150	2,985	CUP Pressures Not Established		
	165	2,835			

⁽¹⁾ Based on sample size $n=10$.

⁽²⁾ Ballistics based on 20" barrel.

**VELOCITY AND PRESSURE:
 VELOCITY AND PRESSURE DATA – CRUSHER (Cont'd)**

Cartridge	Bullet Weight (gr.)	Velocity (fps) Nominal Mean Instrumental @ 15' Test Bbl.	Pressure Limits (CUP/100) ⁽¹⁾		
			Maximum Average Pressure (MAP)	Maximum Probable Lot Mean (MPLM)	Maximum Probable Sample Mean (MPSM)
30-06 Springfield	55 (saboted)	4,050	500	513	532
	110	3,300			
	125	2,645			
		3,125			
	150	2,900			
		2,960			
		3,065			
		3,080			
		3,015			
	165	2,790			
	165-168	2,690			
180	2,750				
	2,860				
200	2,540				
220	2,400				
30-30 Winchester	55 (saboted)	3,365	380	390	404
	125	2,125			
		2,550			
	140	2,500			
	150	2,370			
		2,440			
	160	2,285			
2,380					
170	2,180				
30-40 Krag	180	2,420	400	410	425
	220	2,150			
300 AAC Blackout ⁽²⁾	90	2,500	CUP Pressures Not Established		
	115	2,270			
	120	2,100			
	123	2,280			
	220	1,020			
300 Holland & Holland Magnum	150	3,110	540	554	574
	180	2,870			
	220	2,565			

⁽¹⁾ Based on sample size $n=10$.

⁽²⁾ Ballistics based on 16" barrel.

**VELOCITY AND PRESSURE:
 VELOCITY AND PRESSURE DATA – CRUSHER (Cont’d)**

Cartridge	Bullet Weight (gr.)	Velocity (fps) Nominal Mean Instrumental @ 15' Test Bbl.	Pressure Limits (CUP/100) ⁽¹⁾		
			Maximum Average Pressure (MAP)	Maximum Probable Lot Mean (MPLM)	Maximum Probable Sample Mean (MPSM)
300 Remington Short Action Ultra Magnum	150	3,190	CUP Pressures Not Established		
	165	3,065			
	180	2,950			
300 Remington Ultra Magnum	150	2,910	CUP Pressures Not Established		
		3,440			
	165	3,200			
		3,350			
	180	2,960			
	3,225				
	200	3,025	CUP Pressures Not Established		
300 Ruger Compact Magnum	150	3,280			
	165	3,120			
	180	2,980			
300 Savage	150	2,615	460	472	489
		2,740			
	180	2,340	CUP Pressures Not Established		
300 Weatherby Magnum	165	3,140			
	180	3,125			
	190	2,955			
	220	2,775			
300 Winchester Magnum		2,635	540		
	150	3,275			
		3,390			
		3,110			
	165	3,260			
		2,950			
	180	3,040			
		3,080			
	190	2,875			
		2,800			
200	2,930				
	220	2,665			
300 Winchester Short Magnum	150	3,300	CUP Pressures Not Established		
	165	3,120			
	180	2,970			

⁽¹⁾ Based on sample size $n=10$.

**VELOCITY AND PRESSURE:
 VELOCITY AND PRESSURE DATA – CRUSHER (Cont'd)**

Cartridge	Bullet Weight (gr.)	Velocity (fps) Nominal Mean Instrumental @ 15' Test Bbl.	Pressure Limits (CUP/100) ⁽¹⁾		
			Maximum Average Pressure (MAP)	Maximum Probable Lot Mean (MPLM)	Maximum Probable Sample Mean (MPSM)
303 British	150	2,685 2,820	450	461	478
	174	2,500			
	180	2,450			
	215	2,155			
	307 Winchester	150 180			
308 Marlin Express	140	2,800	CUP Pressures Not Established		
	160	2,645			
308 Winchester	55 (saboted)	3,750	520	533	553
	110	3,150			
	120	3,100			
	125	2,645 3,030			
	130	2,790			
	150	2,800 2,900 2,980			
	165	2,870 2,880			
	165-168	2,670			
	175	2,600			
	180	2,600			
	200	2,440			
	32 Winchester Special	165			
170		2,235			
32-20 Winchester	100	1,200	160	164	170
325 Winchester Short Magnum	180	3,050	CUP Pressures Not Established		
	200	2,940			
	220	2,830			
33 Nosler	250	2,850	CUP Pressures Not Established		
338 Federal	180	2,830	CUP Pressures Not Established		
	185	2,750			
	210	2,630			
338 Lapua Magnum	250	2,950	CUP Pressures Not Established		
	280	2,600			
	285	2,745			
	300	2,620			

⁽¹⁾ Based on sample size $n=10$.

**VELOCITY AND PRESSURE:
 VELOCITY AND PRESSURE DATA – CRUSHER (Cont'd)**

Cartridge	Bullet Weight (gr.)	Velocity (fps) Nominal Mean Instrumental @ 15' Test Bbl.	Pressure Limits (CUP/100) ⁽¹⁾		
			Maximum Average Pressure (MAP)	Maximum Probable Lot Mean (MPLM)	Maximum Probable Sample Mean (MPSM)
338 Marlin Express	200	2,550	CUP Pressures Not Established		
338 Remington Ultra Magnum	250	2,850	CUP Pressures Not Established		
338 Ruger Compact Magnum	185	2,970	CUP Pressures Not Established		
	200	2,940			
	225	2,760			
338 Winchester Magnum	185	3,075	540	554	574
	200	2,940			
	210	2,855			
	225	2,770			
	225	2,950			
	230	2,750			
	250	2,645			
300	2,800				
340 Weatherby Magnum	200	3,210	535	549	569
	210	3,200			
	225	2,860			
	250	2,950			
348 Winchester	200	2,505	400	410	425
35 Nosler	225	3,000	CUP Pressures Not Established		
35 Remington	150	2,275	350	359	372
	200	2,055			
	200	2,200			
35 Whelen	180	2,900	520	533	553
	200	2,660			
	250	2,385			
350 Remington Magnum	200	2,690	530	543	563
	225	2,635			
356 Winchester	200	2,370	520	533	553
	250	2,075			
358 Winchester	200	2,475	520	533	553
	250	2,215			
36 Nosler	250	2,925	CUP Pressures Not Established		
370 Sako Magnum	286	2,550	CUP Pressures Not Established		

⁽¹⁾ Based on sample size n=10.

**VELOCITY AND PRESSURE:
 VELOCITY AND PRESSURE DATA – CRUSHER (Cont'd)**

Cartridge	Bullet Weight (gr.)	Velocity (fps) Nominal Mean Instrumental @ 15' Test Bbl.	Pressure Limits (CUP/100) ⁽¹⁾		
			Maximum Average Pressure (MAP)	Maximum Probable Lot Mean (MPLM)	Maximum Probable Sample Mean (MPSM)
375 Holland & Holland Magnum	250	2,670	530	543	563
		2,890			
	2,680				
	2,850				
375 Remington Ultra Magnum	300	2,515			
	270	2,680	CUP Pressures Not Established		
375 Ruger	300	2,750	CUP Pressures Not Established		
	250	2,890	CUP Pressures Not Established		
	270	2,840	CUP Pressures Not Established		
375 Winchester	300	2,660	CUP Pressures Not Established		
	200	2,180	520	533	553
376 Steyr	250	1,885			
	270	2,580	CUP Pressures Not Established		
38-40 Winchester	180	1,150	140	144	149
38-55 Winchester	255	1,300	300	308	319
405 Winchester	300	2,200	CUP Pressures Not Established		
416 Remington Magnum	350	2,525	540	554	574
	400	2,400			
416 Rigby	400	2,370	CUP Pressures Not Established		
416 Ruger	400	2,410	CUP Pressures Not Established		
416 Weatherby Magnum	400	2,655	535	549	569
44 Remington Magnum ⁽²⁾	210	1,900			
	240	1,740	400	410	425
	275	1,565			
44-40 Winchester	200	1,175	130	133	138
	225	1,000			
444 Marlin	240	2,320			
	265	2,100	440	451	468
		2,400			

⁽¹⁾ Based on sample size $n=10$.

⁽²⁾ Ballistics based on 20" barrel.

**VELOCITY AND PRESSURE:
 VELOCITY AND PRESSURE DATA – CRUSHER (Cont'd)**

Cartridge	Bullet Weight (gr.)	Velocity (fps) Nominal Mean Instrumental @ 15' Test Bbl.	Pressure Limits (CUP/100) ⁽¹⁾		
			Maximum Average Pressure (MAP)	Maximum Probable Lot Mean (MPLM)	Maximum Probable Sample Mean (MPSM)
45-70 Government	250	2,025	280	287	298
	300	1,830			
		1,880			
	325	2,030			
	375	1,490			
	405	1,150			
		1,320			
450 Bushmaster	250	2,250	CUP Pressures Not Established		
	260	2,150			
450 Marlin	325	2,175	CUP Pressures Not Established		
	350	2,125			
457 Wild West Guns	435	1,950	CUP Pressures Not Established		
458 Lott	465	2,380	CUP Pressures Not Established		
	500	2,150			
458 Winchester Magnum	450	2,220	530	543	563
	500	2,025			
		2,240			
	510	2,025			
470 Nitro Express	500	2,150	350	359	372
475 Turnbull	500	1,900	CUP Pressures Not Established		
500 Nitro Express 3"	570	2,125	CUP Pressures Not Established		

⁽¹⁾ Based on sample size $n=10$.

**VELOCITY AND PRESSURE:
 VELOCITY & PRESSURE DATA – TRANSDUCER**

Cartridge	Bullet Weight (gr.)	Velocity (fps) Nominal Mean Instrumental @ 15' Test Bbl.	Pressure Limits (psi/100) ⁽¹⁾		
			Maximum Average Pressure (MAP)	Maximum Probable Lot Mean (MPLM)	Maximum Probable Sample Mean (MPSM)
6 x 45mm	80	2,500	550	564	585
6mm Remington	75	3,400	650	666	691
	80	3,400			
	90	3,175			
	95	3,225			
	100	3,090			
6.5 Creedmoor	120	2,900	620	636	660
	129	2,940			
	140	2,690			
6.5 Grendel	123	2,580	520	533	553
6.5x55 Swedish	129	2,750	510	523	542
	140	2,550			
		2,735			
6.8mm Remington SPC	115	2,610	550	564	585
		2,760			
7mm Mauser (7x57)	139	2,650	510	523	542
		2,820			
	145	2,680			
	154	2,600			
	160	2,500			
7mm Remington Magnum	175	2,420	610	625	648
	125	3,290			
	139	3,150			
		3,230			
	140	2,700			
		3,085			
	150	2,990			
		3,100			
	3,035				
	160-162	2,940			
	175	2,850			

⁽¹⁾ Based on sample size $n=10$.

**VELOCITY AND PRESSURE:
 VELOCITY AND PRESSURE DATA – TRANSDUCER (Cont'd)**

Cartridge	Bullet Weight (gr.)	Velocity (fps) Nominal Mean Instrumental @ 15' Test Bbl.	Pressure Limits (psi/100) ⁽¹⁾		
			Maximum Average Pressure (MAP)	Maximum Probable Lot Mean (MPLM)	Maximum Probable Sample Mean (MPSM)
7mm Remington Short Action Ultra Magnum	140	3,165	650	666	691
	150	3,095			
	160	2,950			
7mm Remington Ultra Magnum	140	3,415	650	666	691
	150	3,315			
	160	3,190			
	175	3,015			
7mm Shooting Times Westerner	140	3,310	650	666	691
	150	3,280			
	160	3,250 3,050			
7mm Weatherby Magnum	140	3,165	650	666	691
	175	2,840			
7mm Winchester Short Magnum	140	3,225	650	666	691
	150	3,200			
	160	2,975			
7mm-08 Remington	120	2,990	610	625	648
	139	2,980			
	140	2,845			
7x64 Brenneke	140	2,950	Piezo Pressures Not Established		
	160	2,600			
7-30 Waters	120	2,700	450	461	478
7.62x39	123	2,350	450	461	478
8mm Mauser (8x57)	170	2,340	350	359	372
8mm Remington Magnum	185	3,065	650	666	691
	200	2,900			
	220	2,815			
9.3 x 62	286	2,360	575	590	612
17 Hornet	15½	3,860	500	513	532
	20	3,625			
17 Remington	20	4,250	630	646	670
	25	4,000			
17 Remington Fireball	20	3,970	550	564	585
	25	3,850			

⁽¹⁾ Based on sample size $n=10$.

**VELOCITY AND PRESSURE:
 VELOCITY AND PRESSURE DATA – TRANSDUCER (Cont'd)**

Cartridge	Bullet Weight (gr.)	Velocity (fps) Nominal Mean Instrumental @ 15' Test Bbl.	Pressure Limits (psi/100) ⁽¹⁾		
			Maximum Average Pressure (MAP)	Maximum Probable Lot Mean (MPLM)	Maximum Probable Sample Mean (MPSM)
204 Ruger	32	4,075	575	590	612
	34	3,990			
	40	3,775			
	45	3,500			
218 Bee	46	2,725	Piezo Pressures Not Established		
22 Hornet	33	3,040	490	502	521
	34	2,985			
	35	3,040			
	45-46	2,655			
22-250 Remington	35	4,350	650	666	691
		4,450			
	40	3,975			
		4,125			
	45	4,000			
	50	3,800			
		4,000			
220 Swift	40	4,040	620	636	660
		4,170			
	50	3,840			
	55	3,650			
	60	3,600			
221 Remington Fireball	50	2,975	Piezo Pressures Not Established		
222 Remington	35	3,760	500	513	532
	40	3,370			
		3,570			
	50-52	3,110			
		3,345			
	55	3,000			
222 Remington Magnum	55	3,215	550	564	585

⁽¹⁾ Based on sample size $\eta=10$.

**VELOCITY AND PRESSURE:
 VELOCITY AND PRESSURE DATA – TRANSDUCER (Cont'd)**

Cartridge	Bullet Weight (gr.)	Velocity (fps) Nominal Mean Instrumental @ 15' Test Bbl.	Pressure Limits (psi/100) ⁽¹⁾						
			Maximum Average Pressure (MAP)	Maximum Probable Lot Mean (MPLM)	Maximum Probable Sample Mean (MPSM)				
223 Remington	35	3,800 4,000	550	564	585				
	40	3,650 3,770							
	42	3,450							
	45	3,550							
	50	3,410							
	53	3,305 3,465							
	55	3,050 3,215							
	60	3,080 3,200							
	62	3,000 3,080 3,240							
	64	3,000 3,070							
	69	2,985							
	75	2,775							
	77	2,670 2,785							
	223 Winchester Super Short Magnum	55				3,850	650	666	691
		64				3,600			
225 Winchester	55	3,540	Piezo Pressures Not Established						
243 Winchester	55	3,880	600	615	638				
	58	3,730 3,925							
	75	3,325 3,580							
	80	3,325							
	85-87	3,300							
	90	3,110							
	95	3,050 3,175							
	100	2,950 3,050							
		3,080							

⁽¹⁾ Based on sample size η=10.

**VELOCITY AND PRESSURE:
 VELOCITY AND PRESSURE DATA – TRANSDUCER (Cont'd)**

Cartridge	Bullet Weight (gr.)	Velocity (fps) Nominal Mean Instrumental @ 15' Test Bbl.	Pressure Limits (psi/100) ⁽¹⁾		
			Maximum Average Pressure (MAP)	Maximum Probable Lot Mean (MPLM)	Maximum Probable Sample Mean (MPSM)
243 Winchester Super Short Magnum	55	4,125	650	666	691
	95	3,250			
	100	3,110			
25 Winchester Super Short Magnum	85	3,470	650	666	691
	110	3,090			
	115	3,060			
	120	2,990			
25-06 Remington	85	3,510	630	646	670
	87	3,420			
	90	3,420			
	100	3,210			
	115	3,100			
	117	2,975			
25-20 Winchester	86	1,445	Piezo Pressures Not Established		
	117	2,210	Piezo Pressures Not Established		
250 Savage	87	3,010	Piezo Pressures Not Established		
	100	2,800	Piezo Pressures Not Established		
257 Roberts	87	3,150	540	554	574
	100	2,880			
	117	2,630			
257 Roberts +P	100	2,980	580	595	617
	117	2,760			
		2,920			
257 Weatherby Magnum	87	3,845	625	641	665
	100	3,580			
	120	3,335			
26 Nosler	129	3,400	650	666	691
260 Remington	120	2,880	600	615	638
	140	2,725			
264 Winchester Magnum	100	3,300	640	656	680
	140	3,015			
27 Nosler	150	3,200	650	666	691
270 Weatherby Magnum	100	3,745	625	641	665
	130	3,350			
	150	3,230			

⁽¹⁾ Based on sample size $n=10$.

**VELOCITY AND PRESSURE:
 VELOCITY AND PRESSURE DATA – TRANSDUCER (Cont'd)**

Cartridge	Bullet Weight (gr.)	Velocity (fps) Nominal Mean Instrumental @ 15' Test Bbl.	Pressure Limits (psi/100) ⁽¹⁾		
			Maximum Average Pressure (MAP)	Maximum Probable Lot Mean (MPLM)	Maximum Probable Sample Mean (MPSM)
270 Winchester	100	3,300	650	666	691
	115	2,695			
		3,050			
	130	3,130			
		3,200			
	135	2,990			
	140	2,950			
		3,090			
		2,830			
	150	2,925			
	2,950				
	3,000				
	160	2,650			
270 Winchester Short Magnum	130	3,275	650	666	691
	140	3,125			
	150	3,150			
28 Nosler	168	3,125	650	666	691
280 Ackley Improved	140	3,260	650	666	691
280 Remington	120	3,135	600	615	638
	139	3,100			
	140	2,985			
	150	2,875			
		2,975			
	165	2,800			
284 Winchester	125	3,125	560	574	595
	150	2,845			
30 Carbine ⁽²⁾	110	1,965	400	410	425
30 Nosler	210	2,950	650	666	691
30 Remington AR	125	2,775	550	564	585
30 Thompson Center	150	2,985	620	636	660
	165	2,835			

⁽¹⁾ Based on sample size $n=10$.
⁽²⁾ Ballistics based on 20" barrel.

**VELOCITY AND PRESSURE:
 VELOCITY AND PRESSURE DATA – TRANSDUCER (Cont'd)**

Cartridge	Bullet Weight (gr.)	Velocity (fps) Nominal Mean Instrumental @ 15' Test Bbl.	Pressure Limits (psi/100) ⁽¹⁾		
			Maximum Average Pressure (MAP)	Maximum Probable Lot Mean (MPLM)	Maximum Probable Sample Mean (MPSM)
30-06 Springfield	55 (saboted)	4,050	600	615	638
	110	3,300			
	125	2,645			
		3,125			
	150	2,900			
		2,960			
		3,065			
		3,080			
	165	3,015			
	165-168	2,790			
		2,690			
180	2,750				
	2,860				
200	2,540				
220	2,400				
30-30 Winchester	55 (saboted)	3,365	420	431	447
	125	2,155			
	140	2,550			
	150	2,370			
		2,440			
	160	2,285			
		2,380			
170	2,180				
30-40 Krag	180	2,420	Piezo Pressures Not Established		
	220	2,150			
300 AAC Blackout ⁽²⁾	90	2,500	550	564	585
	115	2,270			
	120	2,100			
	123	2,280			
	220	1,020			
300 Holland & Holland Magnum	150	3,110	580	595	617
	180	2,870			
	220	2,565			

⁽¹⁾ Based on sample size $n=10$.

⁽²⁾ Ballistics based on 16" barrel.

**VELOCITY AND PRESSURE:
 VELOCITY AND PRESSURE DATA – TRANSDUCER (Cont'd)**

Cartridge	Bullet Weight (gr.)	Velocity (fps) Nominal Mean Instrumental @ 15' Test Bbl.	Pressure Limits (psi/100) ⁽¹⁾		
			Maximum Average Pressure (MAP)	Maximum Probable Lot Mean (MPLM)	Maximum Probable Sample Mean (MPSM)
300 Remington Short Action Ultra Magnum	150	3,190	650	666	691
	165	3,065			
	180	2,950			
300 Remington Ultra Magnum	150	2,910	650	666	691
		3,440			
	165	3,200			
		3,350			
	180	2,960			
	3,225				
	200	3,025			
300 Ruger Compact Magnum	150	3,280	650	666	691
	165	3,120			
	180	2,980			
300 Savage	150	2,615	470	482	500
		2,740			
	180	2,340			
300 Weatherby Magnum	165	3,140	650	666	691
	180	3,125			
	190	2,955			
	220	2,775			
300 Winchester Magnum	150	2,635	640	656	680
		3,275			
		3,390			
	165	3,120			
		3,260			
		2,950			
	180	3,040			
		3,080			
	190	2,875			
	2,800				
	2,930				
	220	2,665			
300 Winchester Short Magnum	150	3,300	650	666	691
	165	3,120			
	180	2,970			

⁽¹⁾ Based on sample size $n=10$.

**VELOCITY AND PRESSURE:
 VELOCITY AND PRESSURE DATA – TRANSDUCER (Cont'd)**

Cartridge	Bullet Weight (gr.)	Velocity (fps) Nominal Mean Instrumental @ 15' Test Bbl.	Pressure Limits (psi/100) ⁽¹⁾		
			Maximum Average Pressure (MAP)	Maximum Probable Lot Mean (MPLM)	Maximum Probable Sample Mean (MPSM)
303 British	150	2,685 2,820	490	502	521
	174	2,500			
	180	2,450			
	215	2,155			
	150	2,705			
180	2,450				
308 Marlin Express	140	2,800	475	487	505
	160	2,645			
308 Winchester	55 (saboted)	3,750	620	636	660
	110	3,150			
	120	3,100			
	125	2,645 3,030			
	130	2,790			
	150	2,800 2,900			
	150	2,980			
	165	2,870 2,880			
	165-168	2,670			
	175	2,600			
	180	2,600			
	200	2,440			
32 Winchester Special	165	2,410	420	431	447
	170	2,235			
32-20 Winchester	100	1,200	Piezo Pressures Not Established		
325 Winchester Short Magnum	180	3,050	650	666	691
	200	2,940			
	220	2,830			
33 Nosler	250	2,850	650	666	691
338 Federal	180	2,830	620	636	660
	185	2,750			
	210	2,630			
338 Lapua Magnum	250	2,950	650	666	691
	280	2,600			
	285	2,745			
	300	2,620			

⁽¹⁾ Based on sample size $n=10$.

**VELOCITY AND PRESSURE:
 VELOCITY AND PRESSURE DATA – TRANSDUCER (Cont'd)**

Cartridge	Bullet Weight (gr.)	Velocity (fps) Nominal Mean Instrumental @ 15' Test Bbl.	Pressure Limits (psi/100) ⁽¹⁾		
			Maximum Average Pressure (MAP)	Maximum Probable Lot Mean (MPLM)	Maximum Probable Sample Mean (MPSM)
338 Marlin Express	200	2,550	460	472	489
338 Remington Ultra Magnum	250	2,850	650	666	691
338 Ruger Compact Magnum	185	2,970	650	666	691
	200	2,940			
	225	2,760			
338 Winchester Magnum	185	3,075	640	656	680
	200	2,940			
	210	2,855			
	225	2,770			
	225	2,950			
	230	2,750			
	250	2,645			
300	2,800				
340 Weatherby Magnum	200	3,210	625	641	665
	210	3,200			
	225	2,860			
	250	2,950			
348 Winchester	200	2,505	Piezo Pressures Not Established		
35 Nosler	225	3,000	650	666	691
35 Remington	150	2,275	335	343	356
	200	2,055			
	200	2,200			
35 Whelen	180	2,900	620	636	660
	200	2,660			
	250	2,385			
350 Remington Magnum	200	2,690	Piezo Pressures Not Established		
	225	2,635			
356 Winchester	200	2,370	Piezo Pressures Not Established		
	250	2,075			
358 Winchester	200	2,475	Piezo Pressures Not Established		
	250	2,215			
36 Nosler	250	2,925	650	666	691
370 Sako Magnum	286	2,550	600	615	638

⁽¹⁾ Based on sample size $n=10$.

**VELOCITY AND PRESSURE:
 VELOCITY AND PRESSURE DATA – TRANSDUCER (Cont'd)**

Cartridge	Bullet Weight (gr.)	Velocity (fps) Nominal Mean Instrumental @ 15' Test Bbl.	Pressure Limits (psi/100) ⁽¹⁾		
			Maximum Average Pressure (MAP)	Maximum Probable Lot Mean (MPLM)	Maximum Probable Sample Mean (MPSM)
375 Holland & Holland Magnum	250	2,670 2,890	620	636	660
	270	2,680 2,850			
	300	2,515 2,680			
375 Remington Ultra Magnum	270		650	666	691
	300	2,750			
375 Ruger	250	2,890	620	636	660
	270	2,840			
	300	2,660			
375 Winchester	200	2,180	Piezo Pressures Not Established		
	250	1,885			
376 Steyr	270	2,580	620	636	660
38-40 Winchester	180	1,150	Piezo Pressures Not Established		
38-55 Winchester	255	1,300	Piezo Pressures Not Established		
405 Winchester	300	2,200	460	472	489
416 Remington Magnum	350	2,525	650	666	691
	400	2,400			
416 Rigby	400	2,370	520	533	553
416 Ruger	400	2,410	620	636	660
416 Weatherby Magnum	400	2,655	Piezo Pressures Not Established		
44 Remington Magnum ⁽²⁾	210	1,900	360	369	383
	240	1,740			
	275	1,565			
44-40 Winchester	200	1,175	110	113	117
	225	1,000			
444 Marlin	240	2,320	420	431	447
	265	2,100 2,400			

⁽¹⁾ Based on sample size $n=10$.

⁽²⁾ Ballistics based on 20" barrel.

**VELOCITY AND PRESSURE:
 VELOCITY AND PRESSURE DATA – CRUSHER (Cont'd)**

Cartridge	Bullet Weight (gr.)	Velocity (fps) Nominal Mean Instrumental @ 15' Test Bbl.	Pressure Limits (psi/100) ⁽¹⁾		
			Maximum Average Pressure (MAP)	Maximum Probable Lot Mean (MPLM)	Maximum Probable Sample Mean (MPSM)
45-70 Government	250	2,025	280	287	298
	300	1,830			
		1,880			
	325	2,030			
	375	1,490			
450 Bushmaster	405	1,150	385	395	410
	250	2,250			
	260	2,150			
450 Marlin	325	2,175	435	446	463
	350	2,125			
457 Wild West Guns	435	1,950	435	446	463
458 Lott	465	2,380	625	641	665
	500	2,150			
458 Winchester Magnum	450	2,220	600	615	638
	500	2,025			
		2,240			
470 Nitro Express	510	2,025	410	420	436
475 Turnbull	500	2,150	420	431	447
500 Nitro Express 3"	500	1,900	385	395	410
	570	2,125			

⁽¹⁾ Based on sample size $n=10$.

BULLET TYPE ABBREVIATIONS

LEAD:

HPHollow Point
LLead
LHPLead Hollow Point
MPMetal Point

JACKETED:

BTBoat Tail
BTHPBoat Tail Hollow Point
FPFlat Point
FMJFull Metal Jacket
FMCFull Metal Case
HPHollow Point
JFJacketed Frangible
JFPJacketed Flat Point
JHPJacketed Hollow Point
JSPJacketed Soft Point
MCMetal Case
OTMOpen Tip Match
PPartition
PHPPlated Hollow Point
PSPPointed Soft Point
PTPolymer Tip
SSpitzer
SPSoft Point
XPeXpanding Point

SEMI-JACKETED:

SJHPSemi-Jacketed Hollow Point
SJSPSemi-Jacketed Soft Point

OTHER:

HCHard Cast
SolidIndicates a bullet constructed of a single material other than lead.

NOTE: The abbreviations presented here are those which are generic indications of construction features of a projectile. Abbreviations indicative of a specific manufacturer's brand or trademarked name are beyond the scope of this table.

PRIMERS AND PRIMER POCKETS

CUP MAY BE ROUNDED OR FLAT

“Small Rifle” Primer

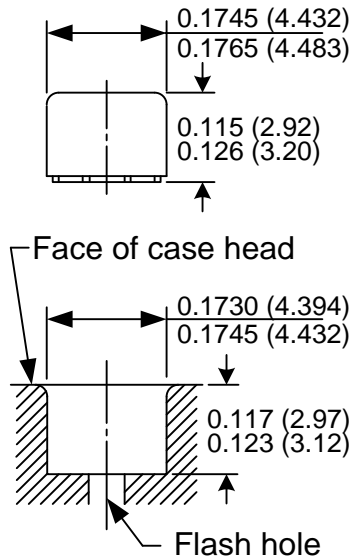

“Large Rifle” Primer

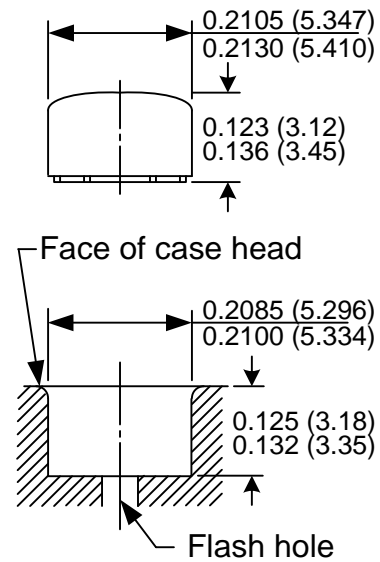

**PRIMERS TO BE SEATED FLUSH TO 0.008” (0.20)
BELOW FACE OF CARTRIDGE CASE HEAD**

NOTE

(XX.XX) = MILLIMETERS

NOTICE: This drawing is subject to change.
 Current version is available at www.saami.org.

MAXIMUM CARTRIDGE / MINIMUM CHAMBER

6x45MM

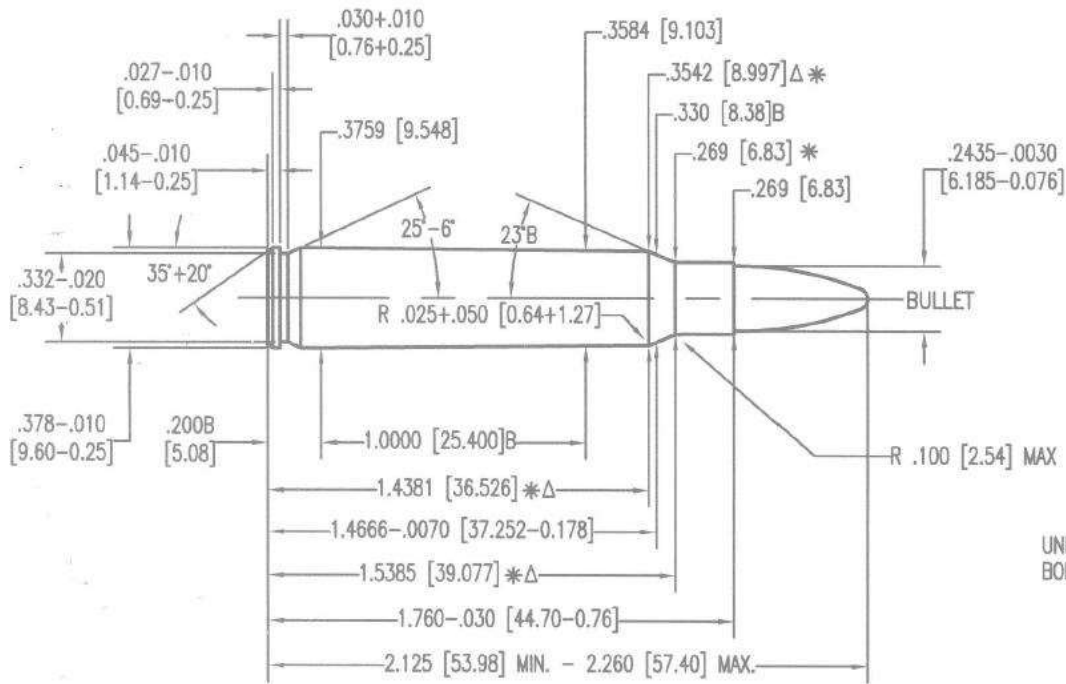

CARTRIDGE
 UNLESS OTHERWISE NOTED
 BODY DIA. -.008 [.20]

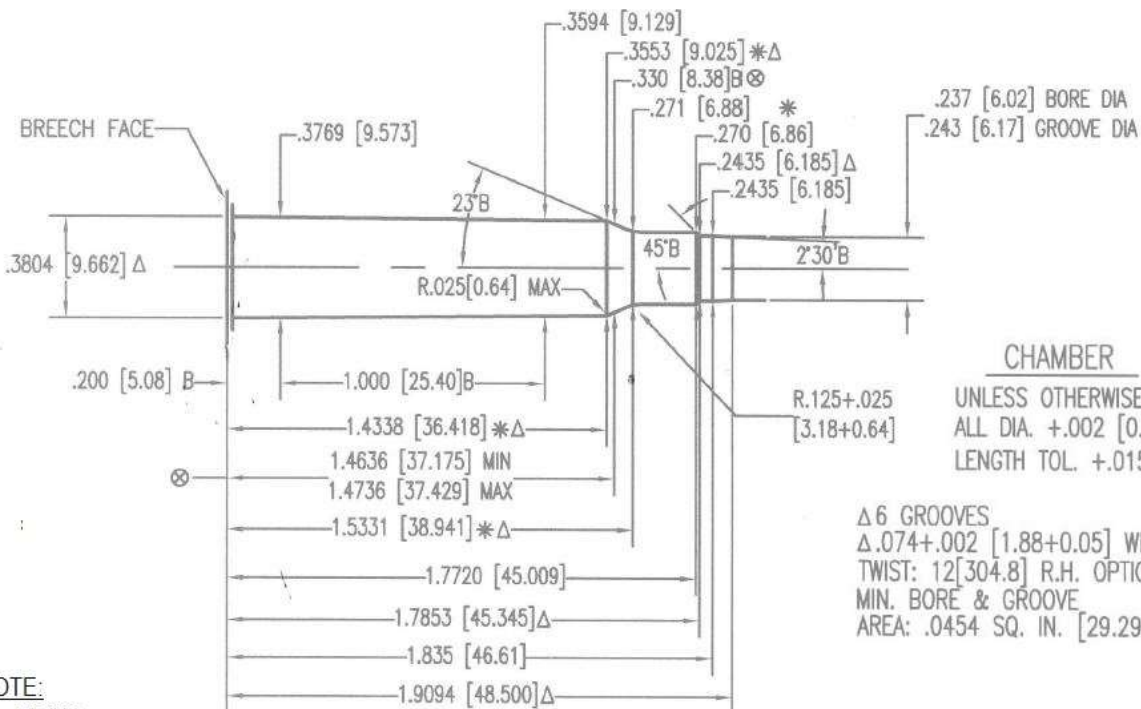

CHAMBER
 UNLESS OTHERWISE NOTED
 ALL DIA. +.002 [0.05]
 LENGTH TOL. +.015 [0.38]

Δ 6 GROOVES
 Δ .074+.002 [1.88+0.05] WIDE
 TWIST: 12[304.8] R.H. OPTIONAL
 MIN. BORE & GROOVE
 AREA: .0454 SQ. IN. [29.290 mm²]

NOTE:
 B = BASIC
 [XX.XX] = MILLIMETERS ⊗ = HEADSPACE DIMENSIONS Δ = REFERENCE DIMENSIONS
 * = DIMENSIONS ARE TO INTERSECTIONS OF LINES
 ALL CALCULATIONS APPLY AT MAXIMUM MATERIAL CONDITION (MMC)

6X45mm

NOTICE: This drawing is subject to change.
 Current version is available at www.saami.org.

MAXIMUM CARTRIDGE / MINIMUM CHAMBER

6MM REMINGTON

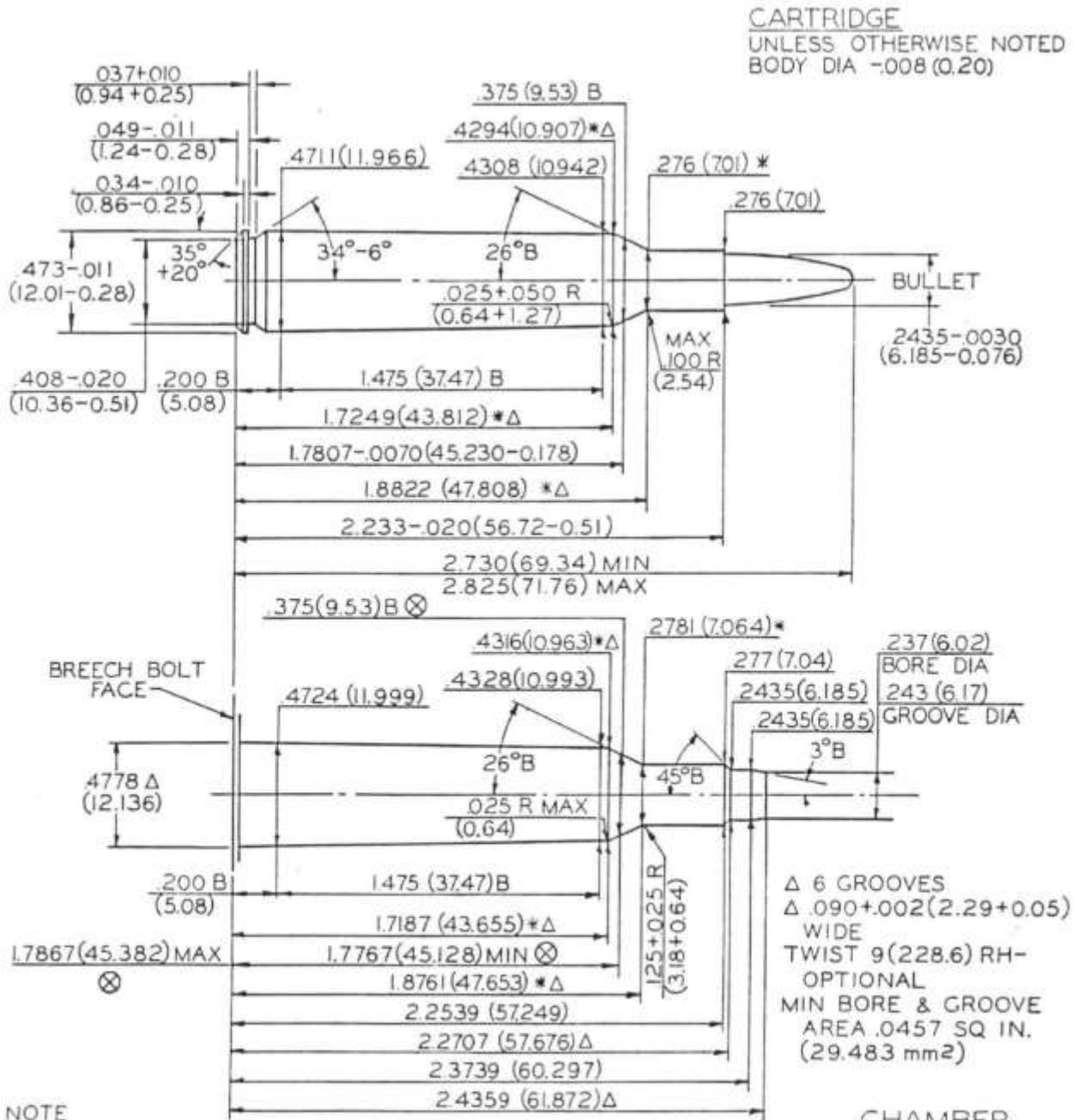

NOTE
 B=BASIC
 (XX.XX)=MILLIMETERS
 ⊗ = HEADSPACE DIMENSION
 Δ = REFERENCE DIMENSION
 * DIMENSIONS ARE TO INTERSECTION OF LINES
 ALL CALCULATIONS APPLY AT MAXIMUM MATERIAL CONDITION (MMC)

6mm REMINGTON

NOTICE: This drawing is subject to change.
 Current version is available at www.saami.org.

MAXIMUM CARTRIDGE / MINIMUM CHAMBER

6.5 CREEDMOOR

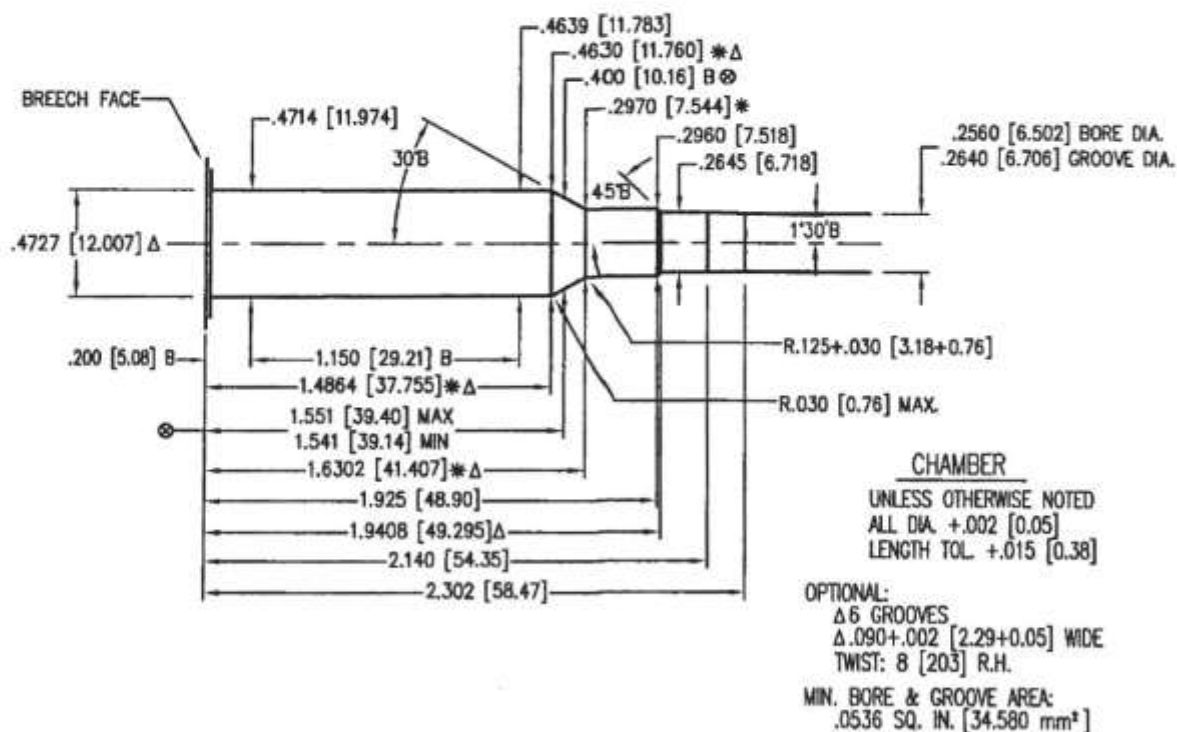
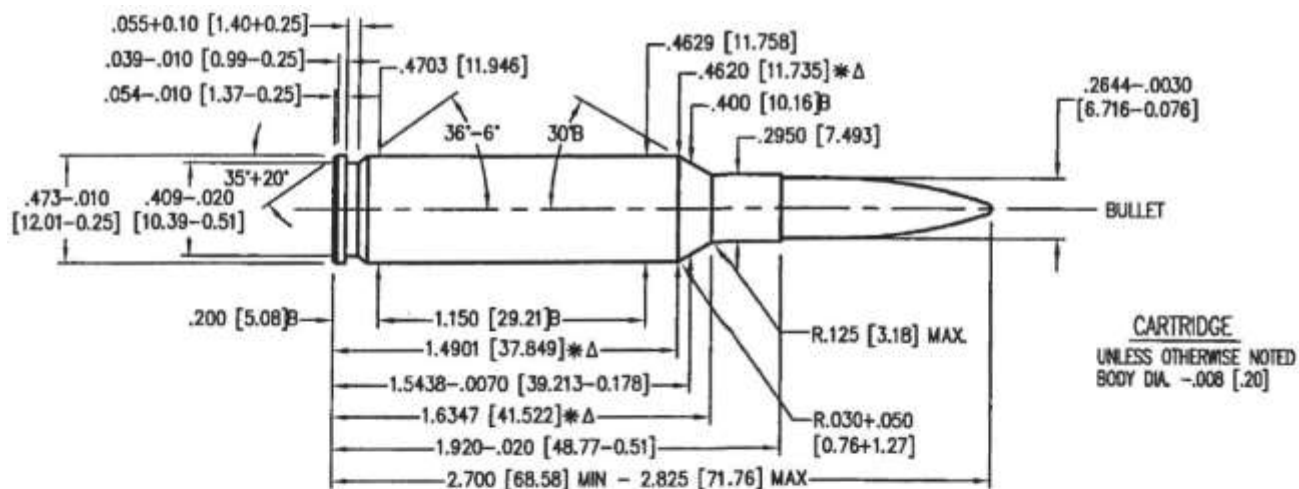

NOTE:
 B=BASIC
 [XX.XX]=MILLIMETERS ⊗ = HEADSPACE DIMENSION Δ = REFERENCE DIMENSION
 * DIMENSIONS ARE TO INTERSECTION OF LINES
 ALL CALCULATIONS APPLY AT MAXIMUM MATERIAL CONDITION (MMC)

NOTICE: This drawing is subject to change.
 Current version is available at www.saami.org.

MAXIMUM CARTRIDGE / MINIMUM CHAMBER

6.5 GRENDSEL

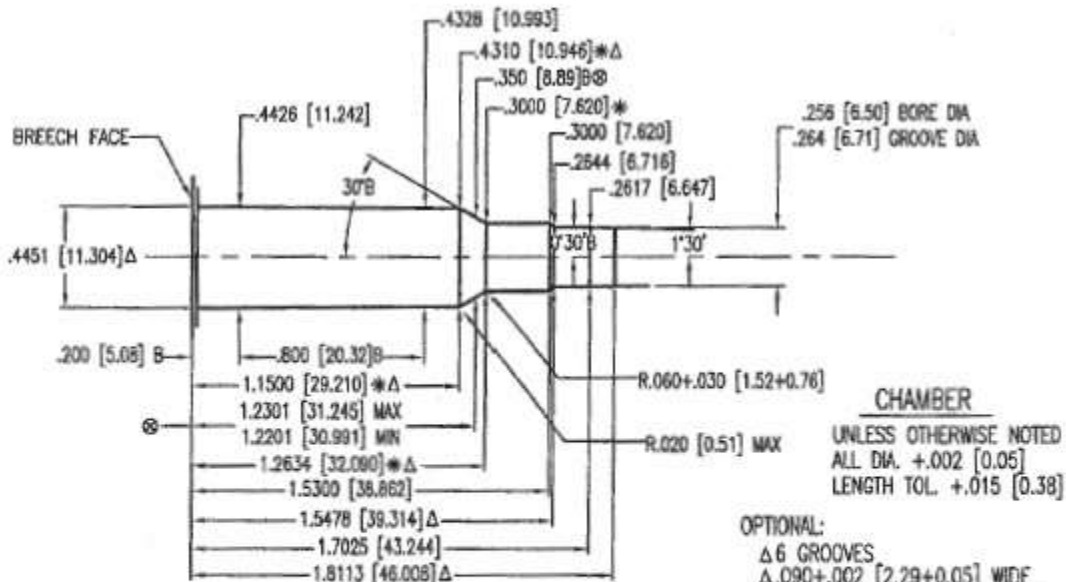
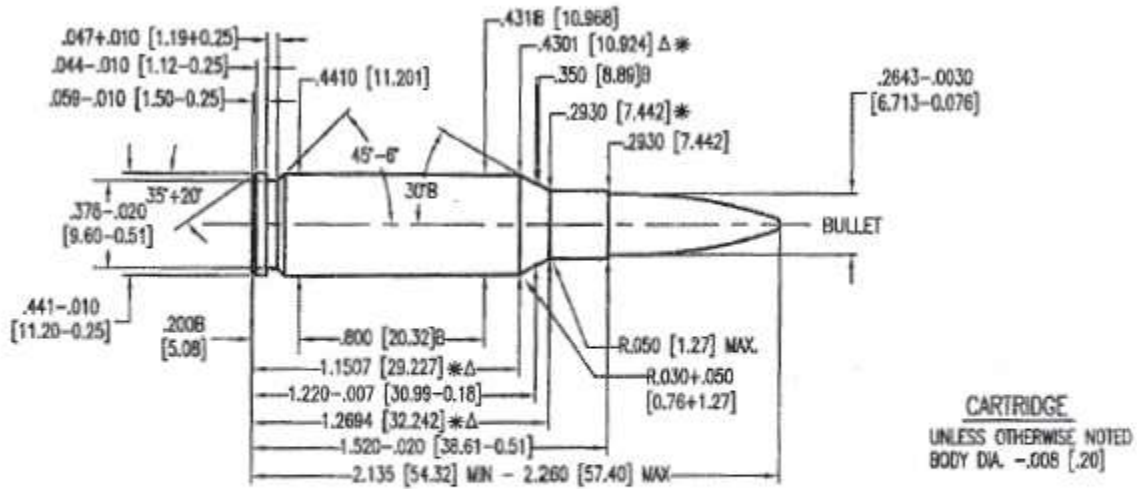

NOTE:
 B=BASIC
 [XX.XX]=MILLIMETERS
 ⊗ = HEADSPACE DIMENSION
 Δ = REFERENCE DIMENSION
 * DIMENSIONS ARE TO INTERSECTION OF LINES
 ALL CALCULATIONS APPLY AT MAXIMUM MATERIAL CONDITION (MMC)

OPTIONAL:
 Δ 6 GROOVES
 Δ .090+.002 [2.29+0.05] WIDE
 TWIST: 8 [203.2] R.H. OPTIONAL
 MIN. BORE & GROOVE
 AREA: .0536 SQ. IN. [34.581 mm²]

6.5 GRENDSEL

NOTICE: This drawing is subject to change.
 Current version is available at www.saami.org.

MAXIMUM CARTRIDGE / MINIMUM CHAMBER

6.5x55 SWEDISH

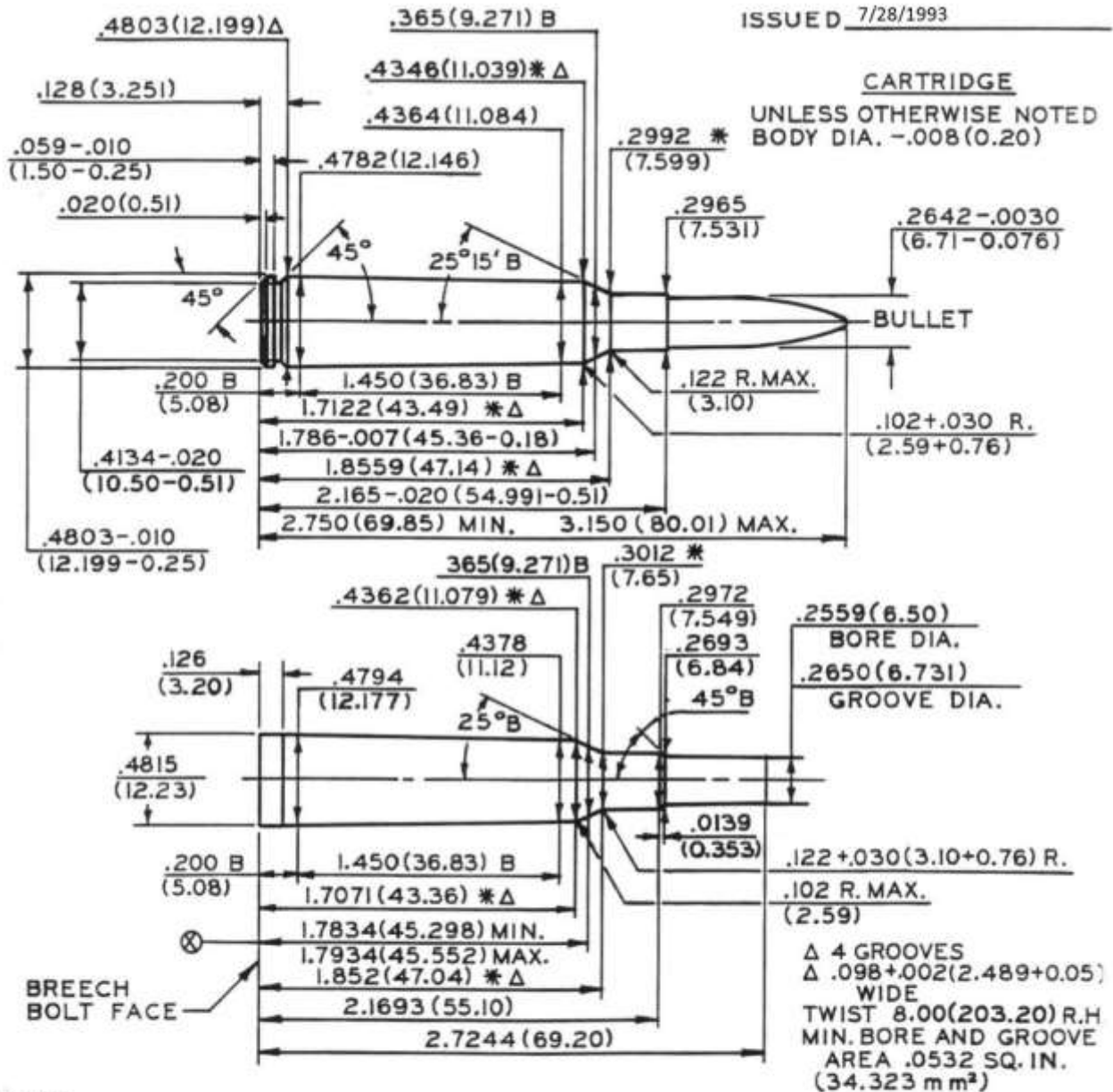

NOTICE: This drawing is subject to change.
 Current version is available at www.saami.org.

MAXIMUM CARTRIDGE / MINIMUM CHAMBER

6.8MM REMINGTON SPC

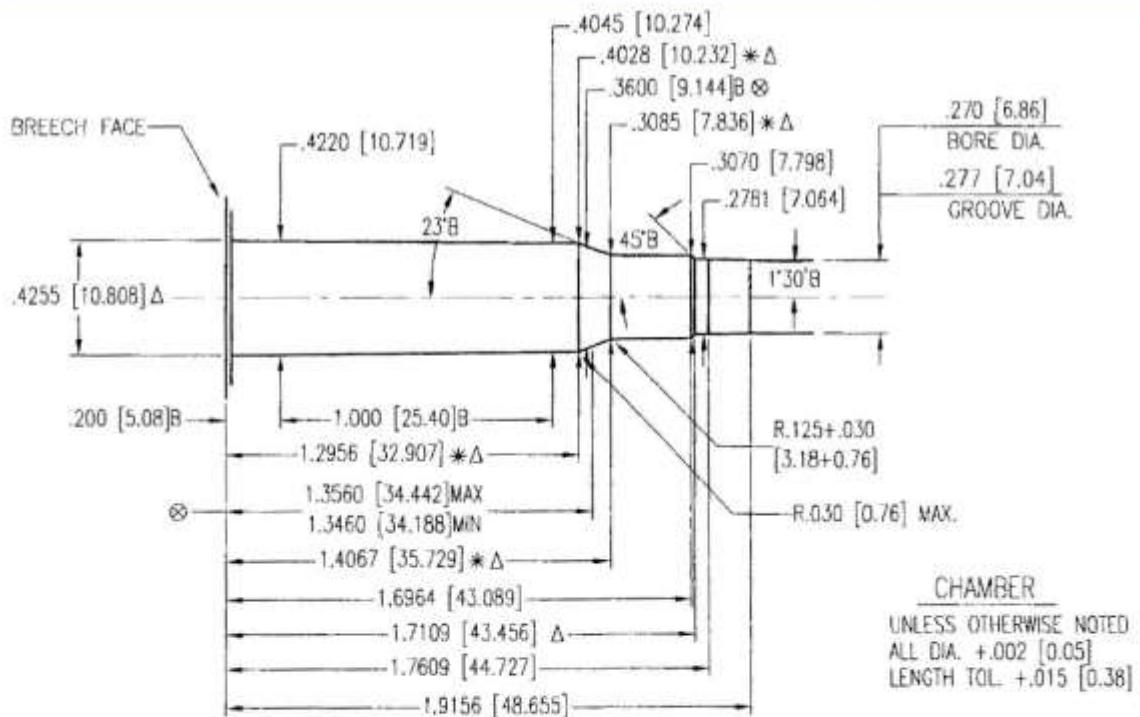
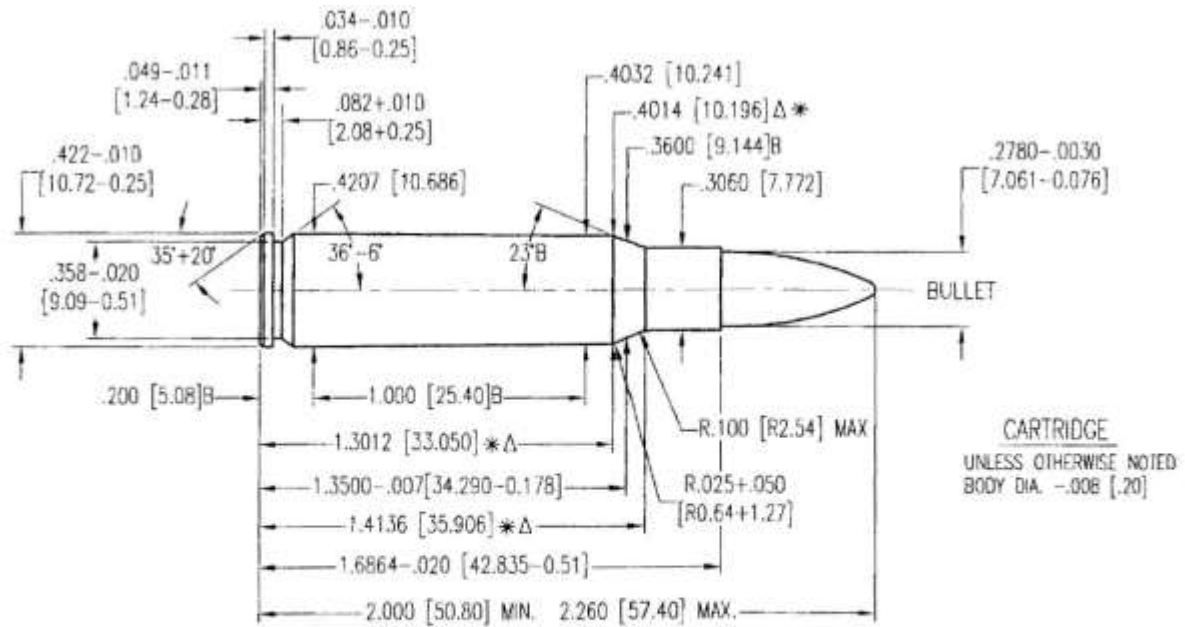

Δ 4 GROOVES
 Δ .160 ± 0.002 [4.06 ± 0.05] WIDE
 TWIST: 10 [254] R.H. OPTIONAL
 MIN. BORE & GROOVE
 AREA: .0596 SQ. IN. [38.451 mm²]

NOTE:
 B=BASIC
 [XX.XX]=MILLIMETERS
 ⊗ = HEADSPACE DIMENSION
 Δ = REFERENCE DIMENSION
 * DIMENSIONS ARE TO INTERSECTION OF LINES
 ALL CALCULATIONS APPLY AT MAXIMUM MATERIAL CONDITION (MMC)

6.8MM REMINGTON SPC

NOTICE: This drawing is subject to change.
 Current version is available at www.saami.org.

MAXIMUM CARTRIDGE / MINIMUM CHAMBER

7MM MAUSER (7X57)

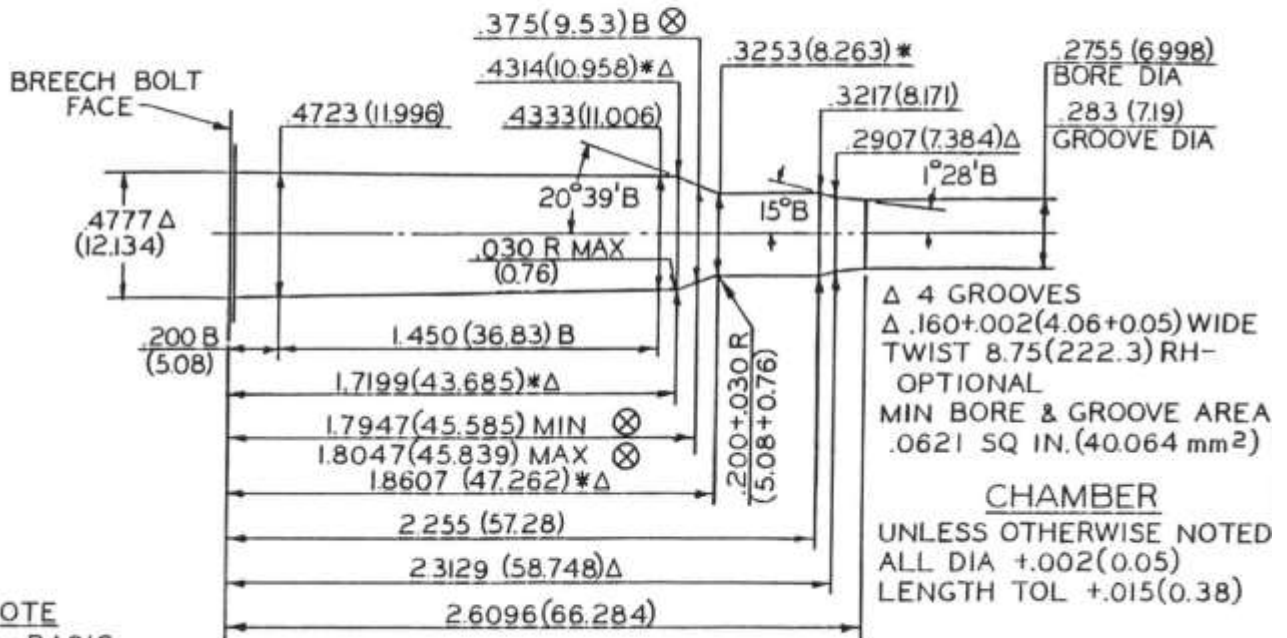
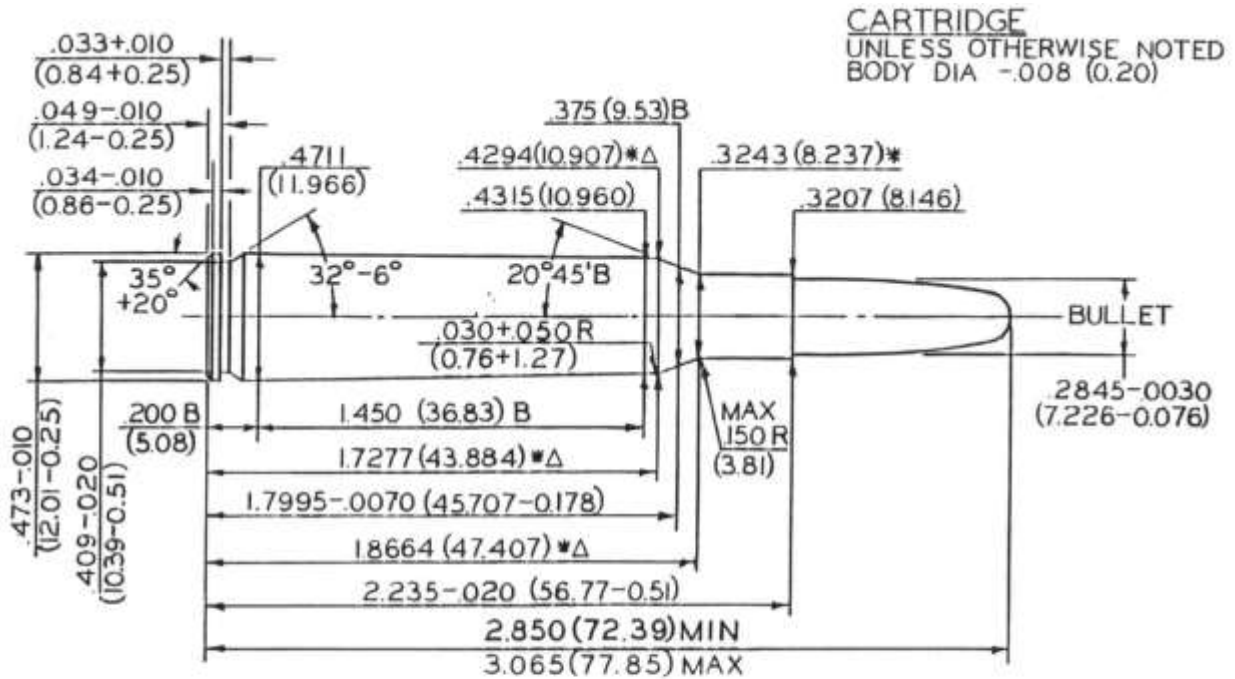

NOTE

B = BASIC

(XX.XX) = MILLIMETERS

* DIMENSIONS ARE TO INTERSECTION OF LINES

ALL CALCULATIONS APPLY AT MAXIMUM MATERIAL CONDITION (MMC)

\otimes = HEADSPACE DIMENSION

Δ = REFERENCE DIMENSION

7mm MAUSER (7x57)

NOTICE: This drawing is subject to change.
 Current version is available at www.saami.org.

MAXIMUM CARTRIDGE / MINIMUM CHAMBER

7MM REMINGTON MAGNUM

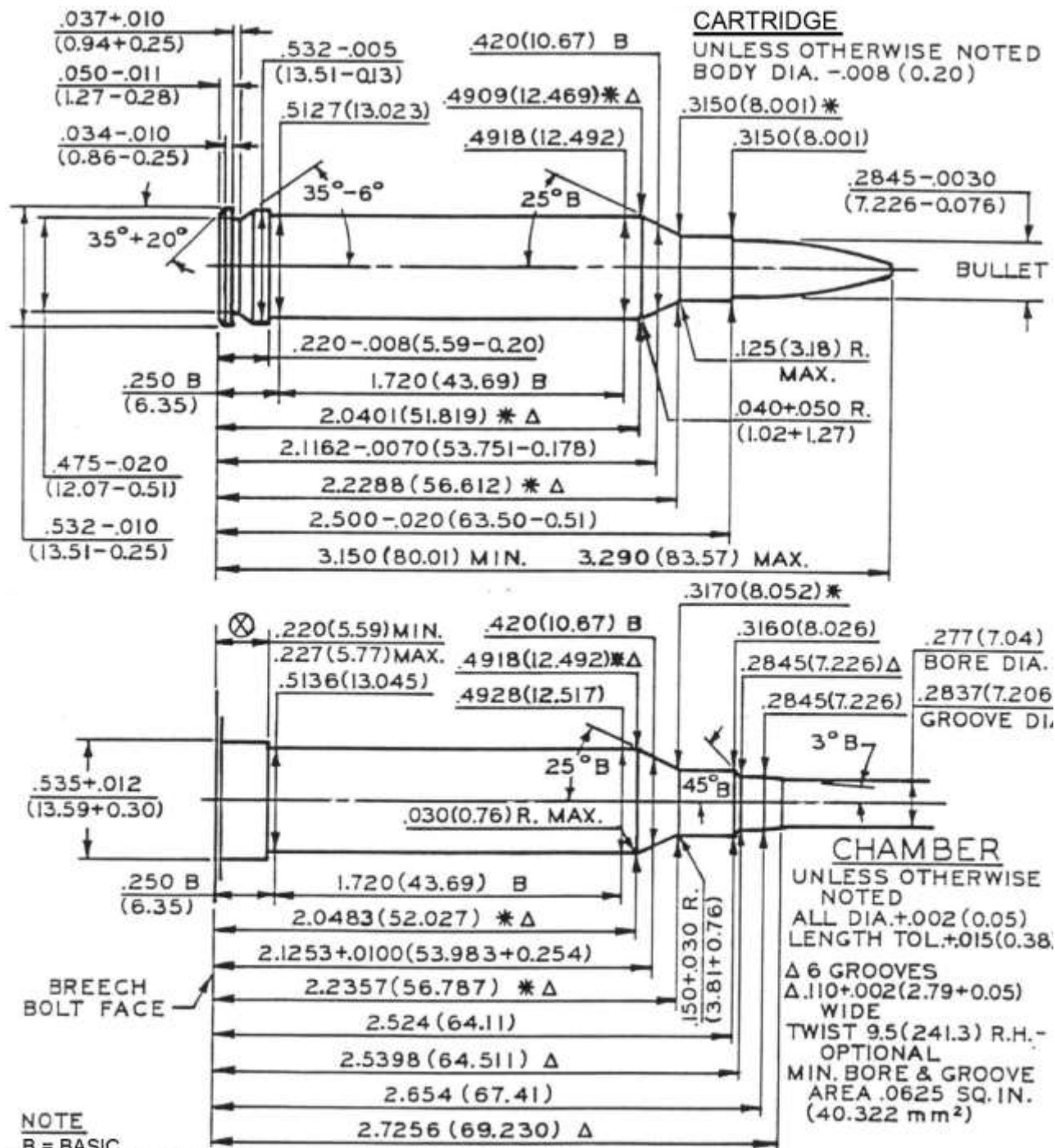

7-18-1990

7mm REMINGTON MAGNUM

NOTICE: This drawing is subject to change.
 Current version is available at www.saami.org.

MAXIMUM CARTRIDGE / MINIMUM CHAMBER
**7MM REMINGTON
 SHORT ACTION ULTRA MAGNUM**

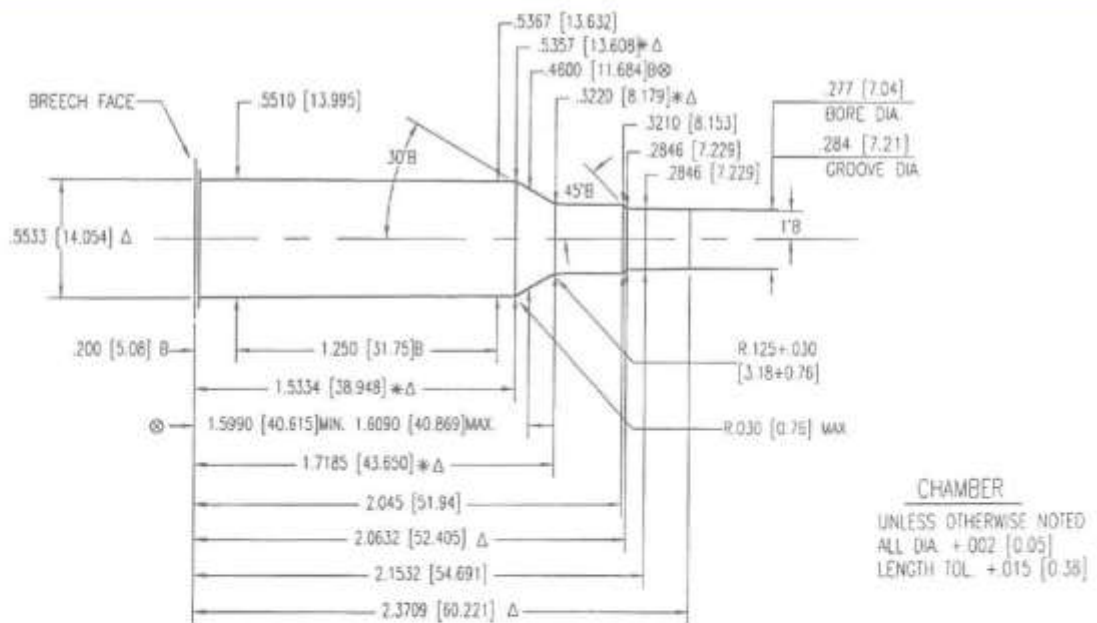
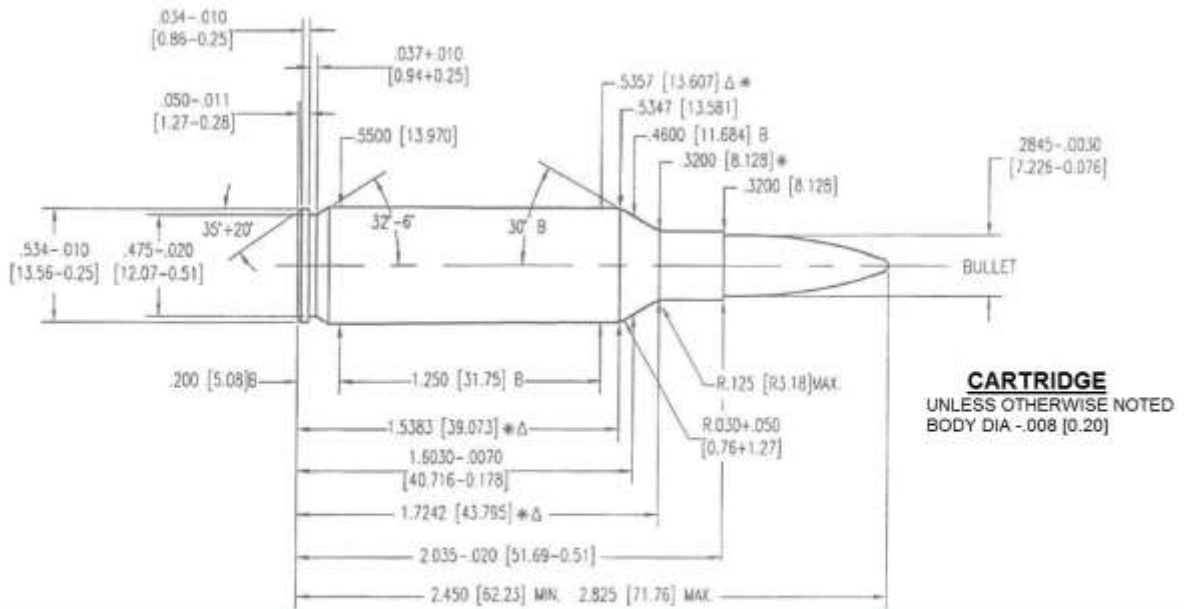

NOTE:
 B=BASIC
 [XX.XX]=MILLIMETERS
 ⊗ = HEADSPACE DIMENSION
 Δ = REFERENCE DIMENSION
 * DIMENSIONS ARE TO INTERSECTION OF LINES
 ALL CALCULATIONS APPLY AT MAXIMUM MATERIAL CONDITION (MMC)

Δ 6 GROOVES
 Δ .110+.002 [2.79+0.05] WIDE
 TWIST: 9.25 [236] R.H. OPTIONAL
 MIN. BORE & GROOVE
 AREA: .0626 SQ. IN. [40.390 mm²]

7mm REMINGTON SHORT ACTION ULTRA MAGNUM

NOTICE: This drawing is subject to change.
 Current version is available at www.saami.org.

MAXIMUM CARTRIDGE / MINIMUM CHAMBER
7MM REMINGTON ULTRA MAGNUM

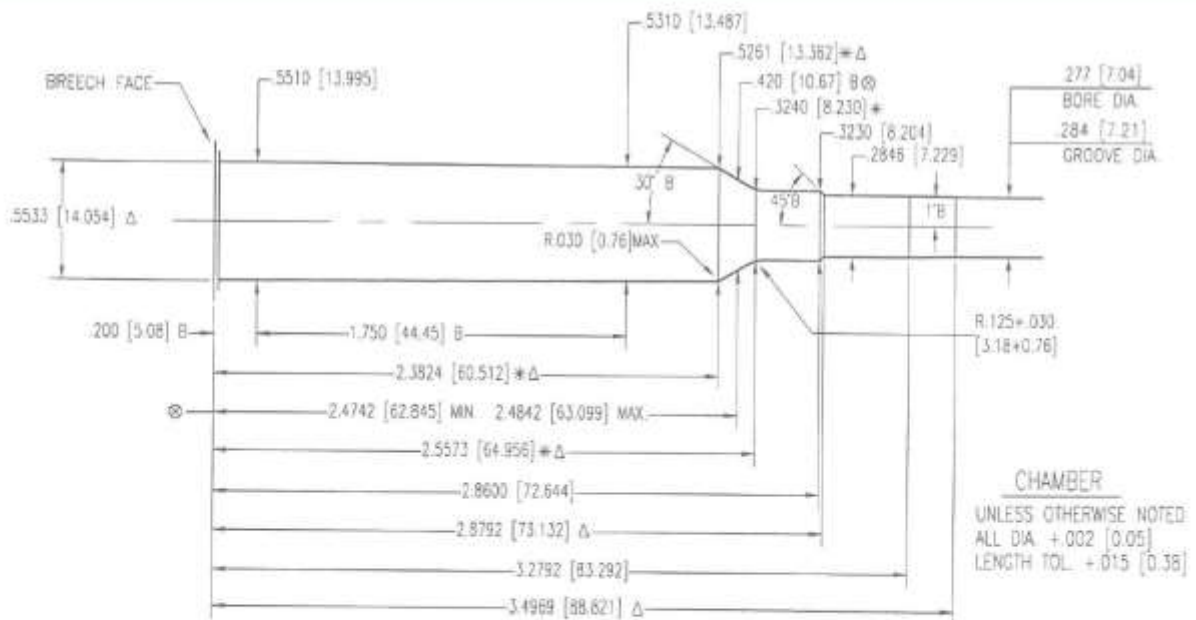
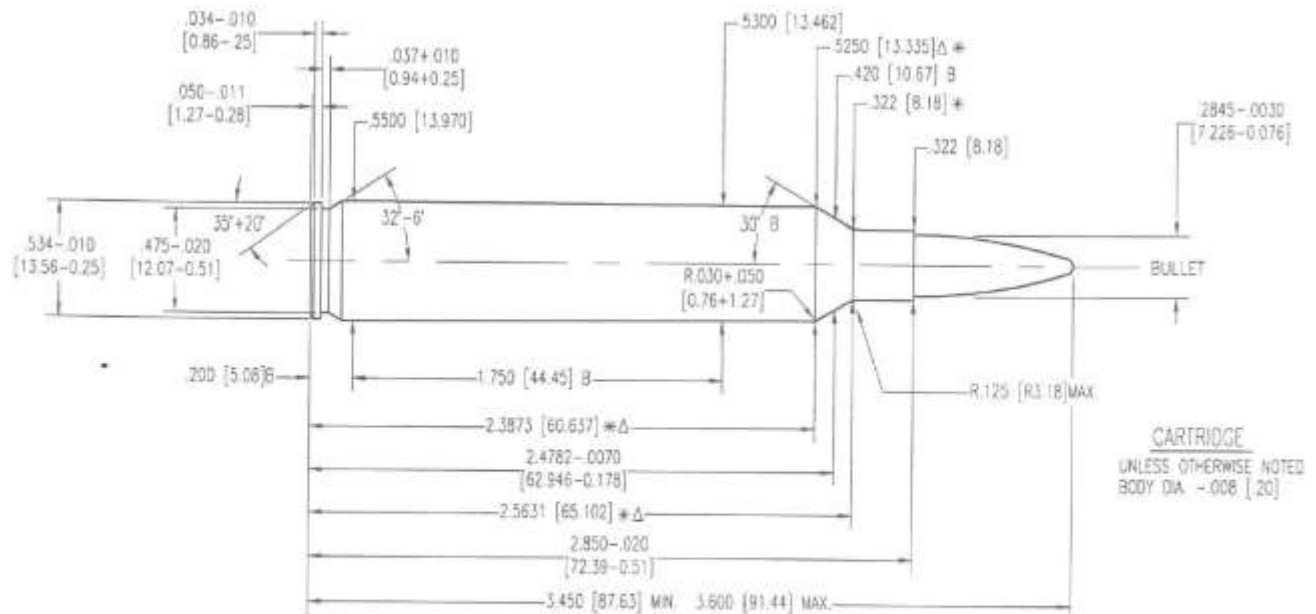

NOTE:
 B=BASIC
 [XX.XX]=MILLIMETERS
 ⊕ = HEADSPACE DIMENSION
 Δ = REFERENCE DIMENSION
 + DIMENSIONS ARE TO INTERSECTION OF LINES
 ALL CALCULATIONS APPLY AT MAXIMUM MATERIAL CONDITION (MMC)

Δ 6 GROOVES
 Δ.110 $+0.002$ [2.79 $+0.05$] WIDE
 TWIST: 9.5[241.3] R.H. OPTIONAL
 MIN. BORE & GROOVE
 AREA: .0625 SQ. IN [40.322 mm²]

7mm REMINGTON ULTRA MAGNUM

NOTICE: This drawing is subject to change.
 Current version is available at www.saami.org.

MAXIMUM CARTRIDGE / MINIMUM CHAMBER
7MM SHOOTING TIMES WESTERNER

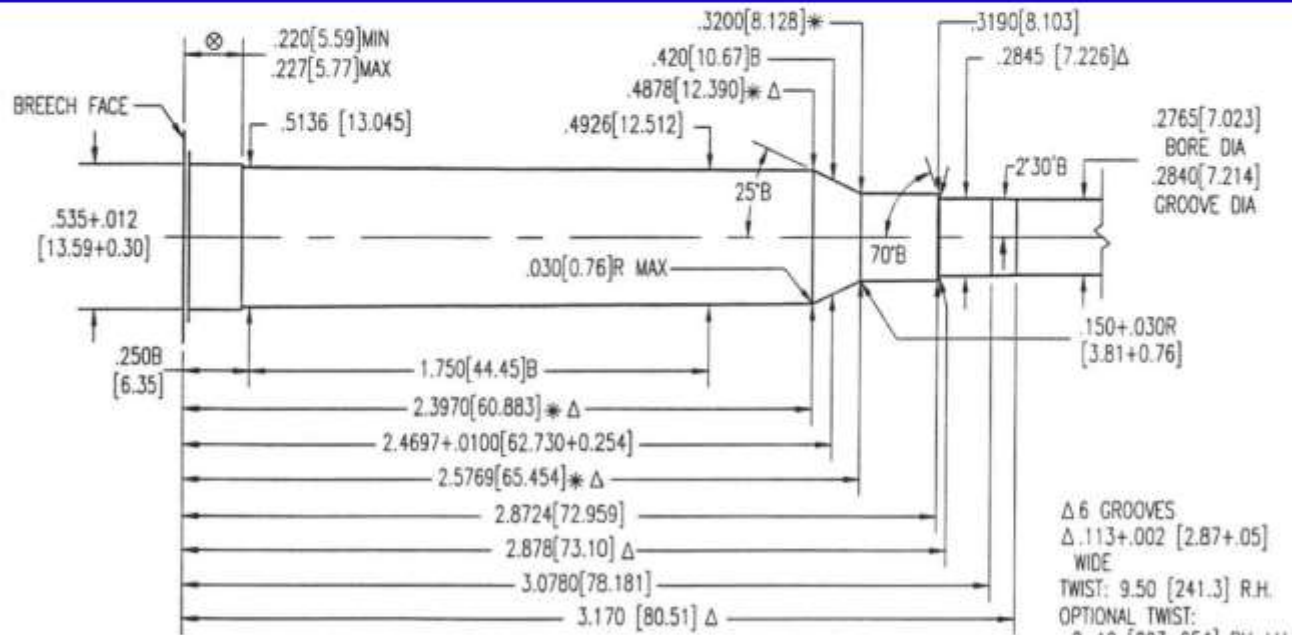
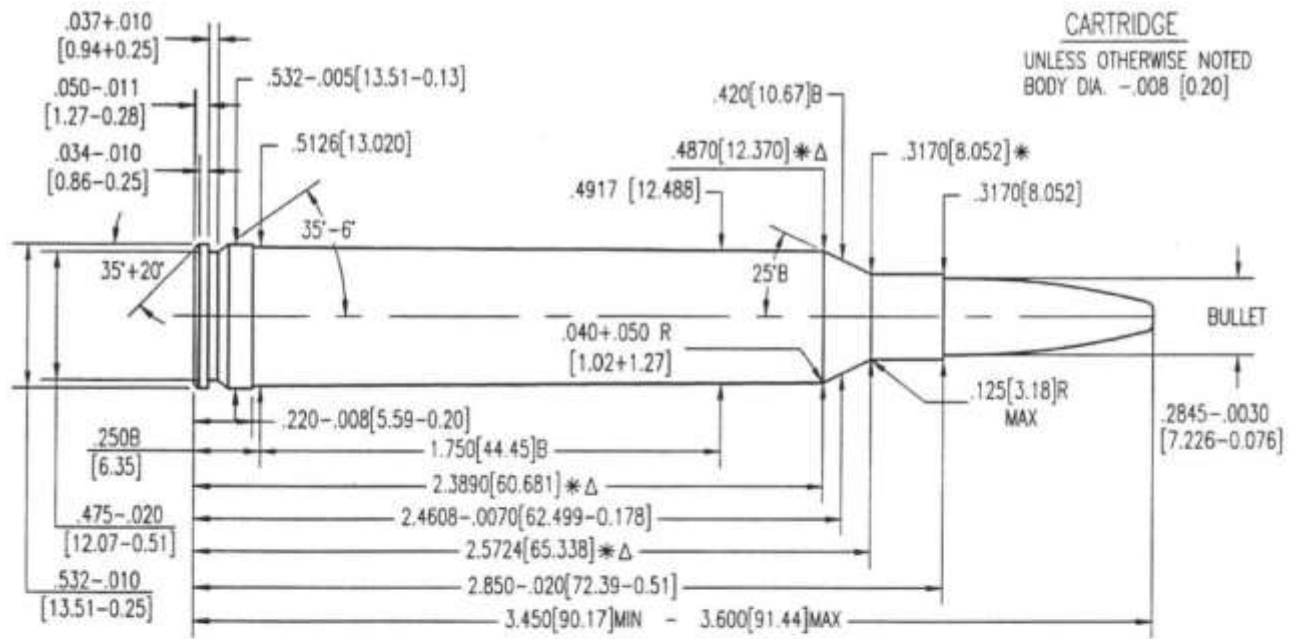

NOTE:
 B=BASIC
 [XX.XX]=MILLIMETERS
 ⊗ = HEADSPACE DIMENSION
 Δ = REFERENCE DIMENSION
 * DIMENSIONS ARE TO INTERSECTION OF LINES
 ALL CALCULATIONS APPLY AT MAXIMUM MATERIAL CONDITION (MMC)

Δ 6 GROOVES
 Δ .113 $+.002$ [2.87 $+0.05$]
 WIDE
 TWIST: 9.50 [241.3] R.H.
 OPTIONAL TWIST:
 8-10 [203-254] RH-LH
 MIN. BORE & GROOVE
 AREA: .0626 SQ. IN.
 [40.387 SQ. MM]

NOTICE: This drawing is subject to change.
 Current version is available at www.saami.org.

MAXIMUM CARTRIDGE / MINIMUM CHAMBER
7MM WEATHERBY MAGNUM

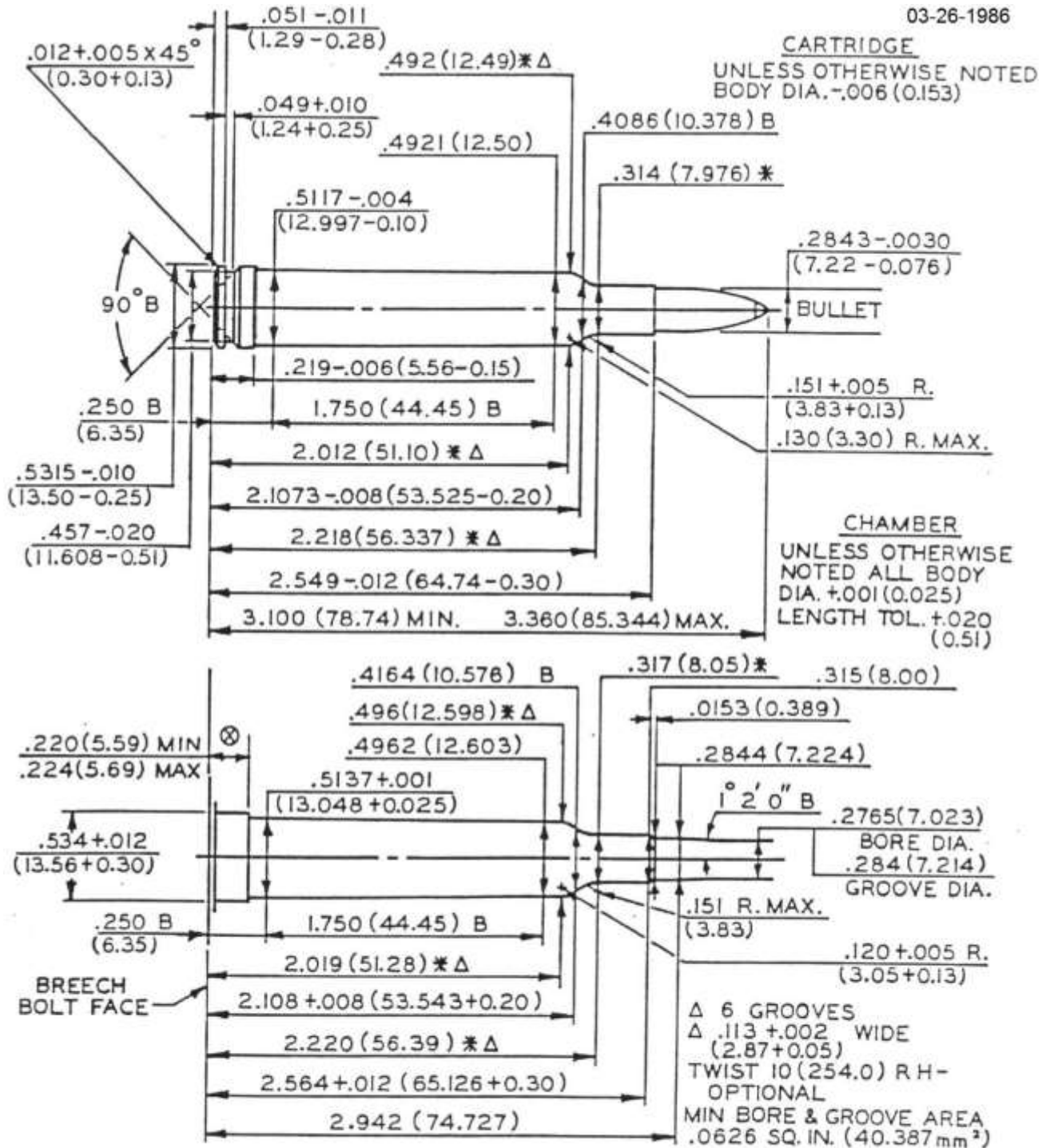

NOTICE: This drawing is subject to change.
 Current version is available at www.saami.org.

MAXIMUM CARTRIDGE / MINIMUM CHAMBER
7MM WINCHESTER SHORT MAGNUM

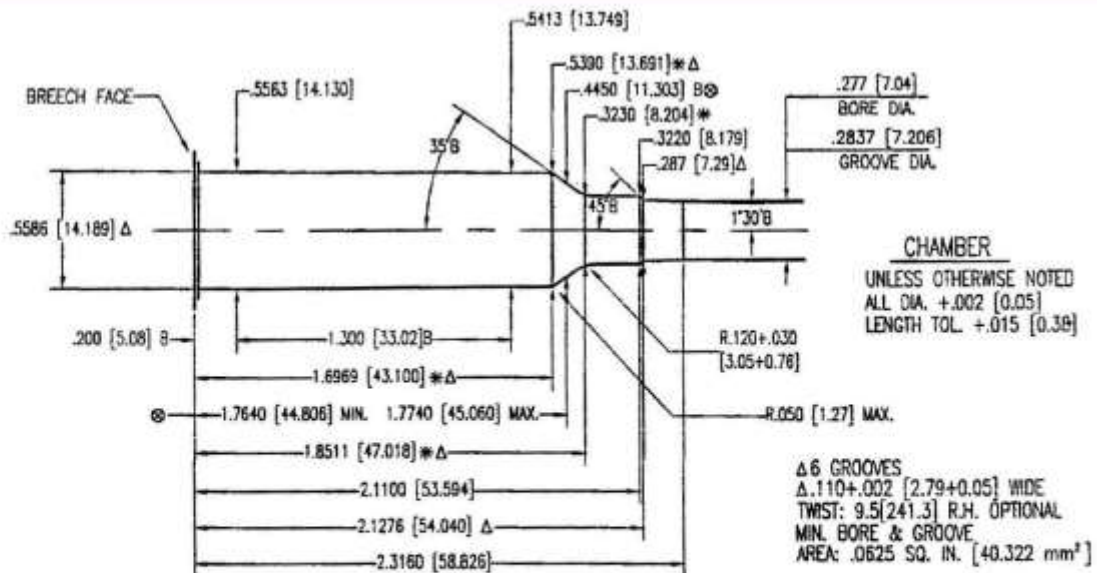
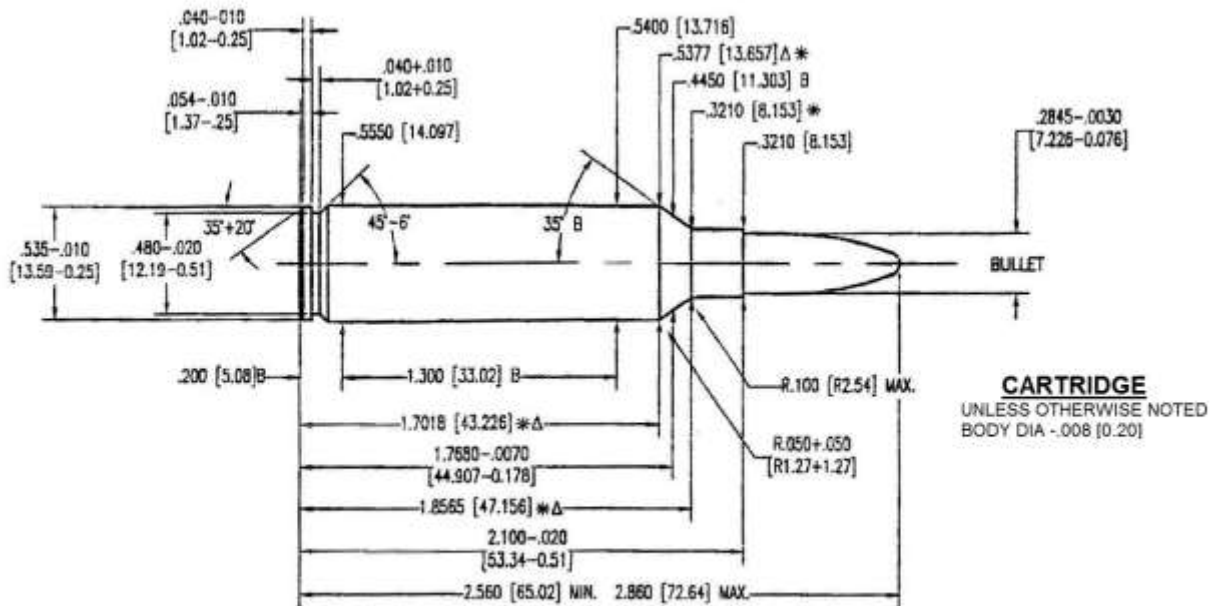

NOTE:
 B=BASIC
 [XX.XX]=MILLIMETERS
 ⊕ = HEADSPACE DIMENSION
 Δ = REFERENCE DIMENSION
 * DIMENSIONS ARE TO INTERSECTION OF LINES
 ALL CALCULATIONS APPLY AT MAXIMUM MATERIAL CONDITION (MMC)

7mm WINCHESTER SHORT MAGNUM

NOTICE: This drawing is subject to change.
 Current version is available at www.saami.org.

MAXIMUM CARTRIDGE / MINIMUM CHAMBER

7MM-08 REMINGTON

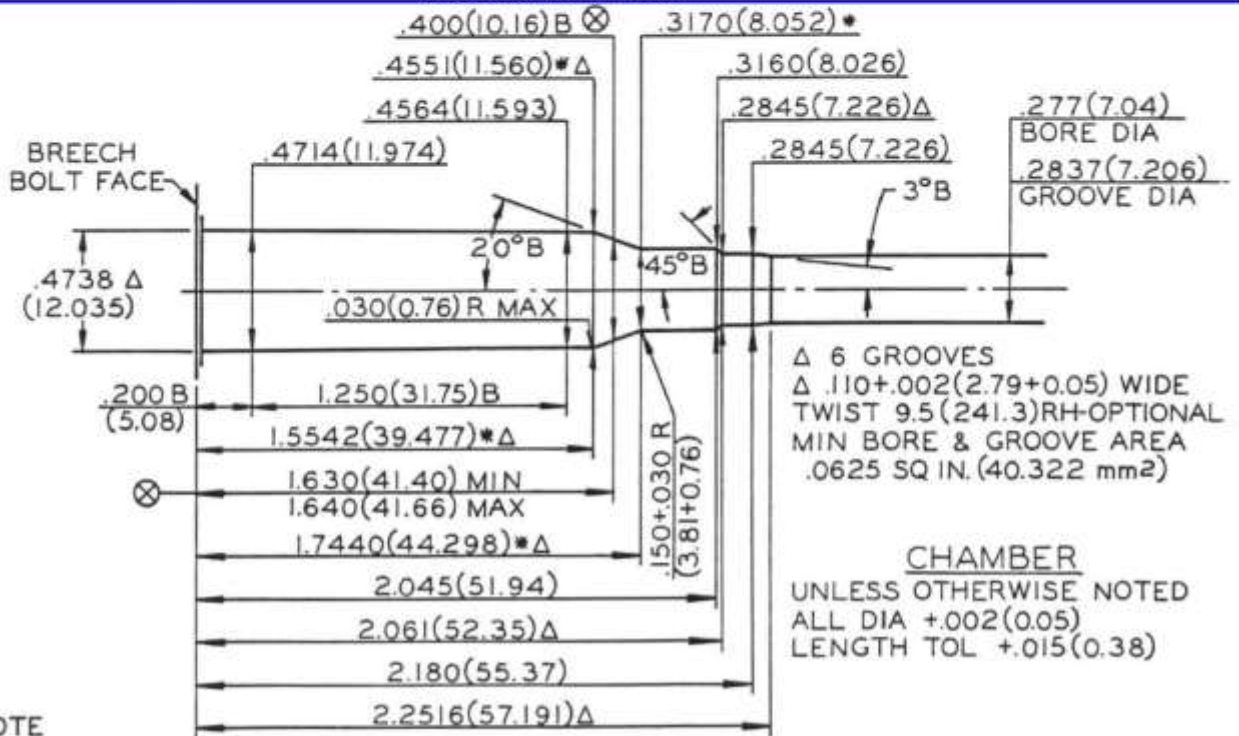
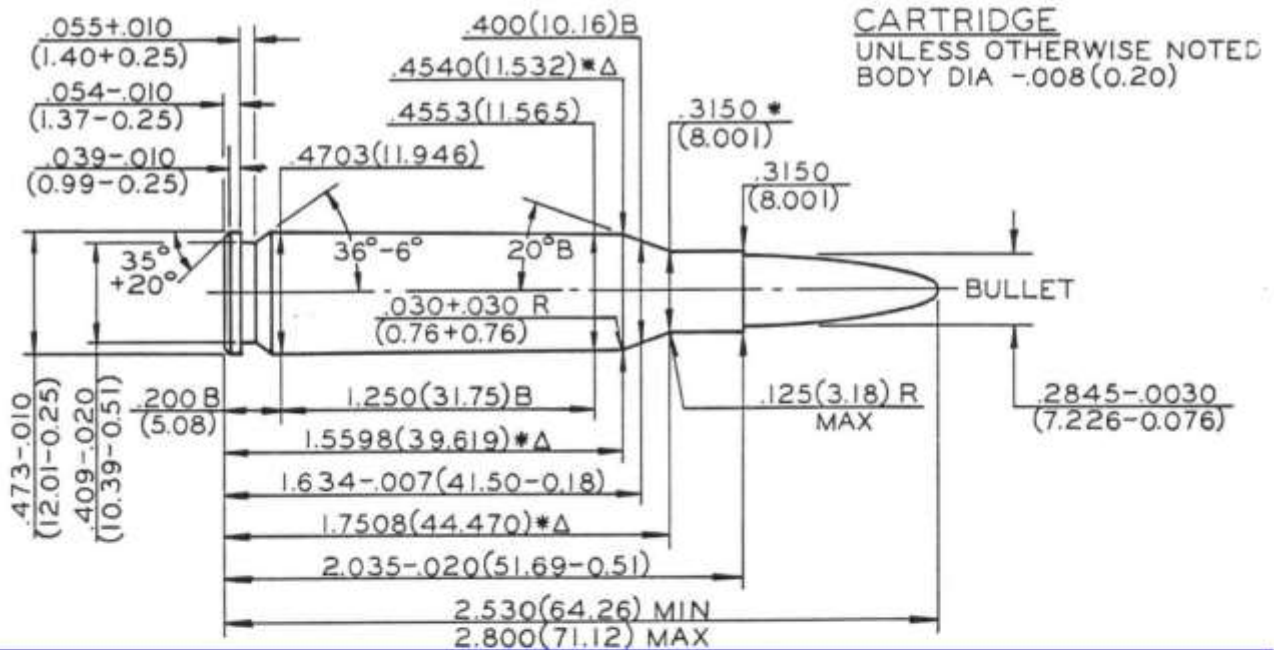

NOTE

B = BASIC
 * DIMENSIONS ARE TO INTERSECTION OF LINES
 ALL CALCULATIONS APPLY AT MAXIMUM MATERIAL CONDITION (MMC)

(XX.XX) = MILLIMETERS

⊗ = HEADSPACE DIMENSION
 Δ = REFERENCE DIMENSION

7mm-08 REMINGTON

NOTICE: This drawing is subject to change.
 Current version is available at www.saami.org.

MAXIMUM CARTRIDGE / MINIMUM CHAMBER

7X64 BRENEKE

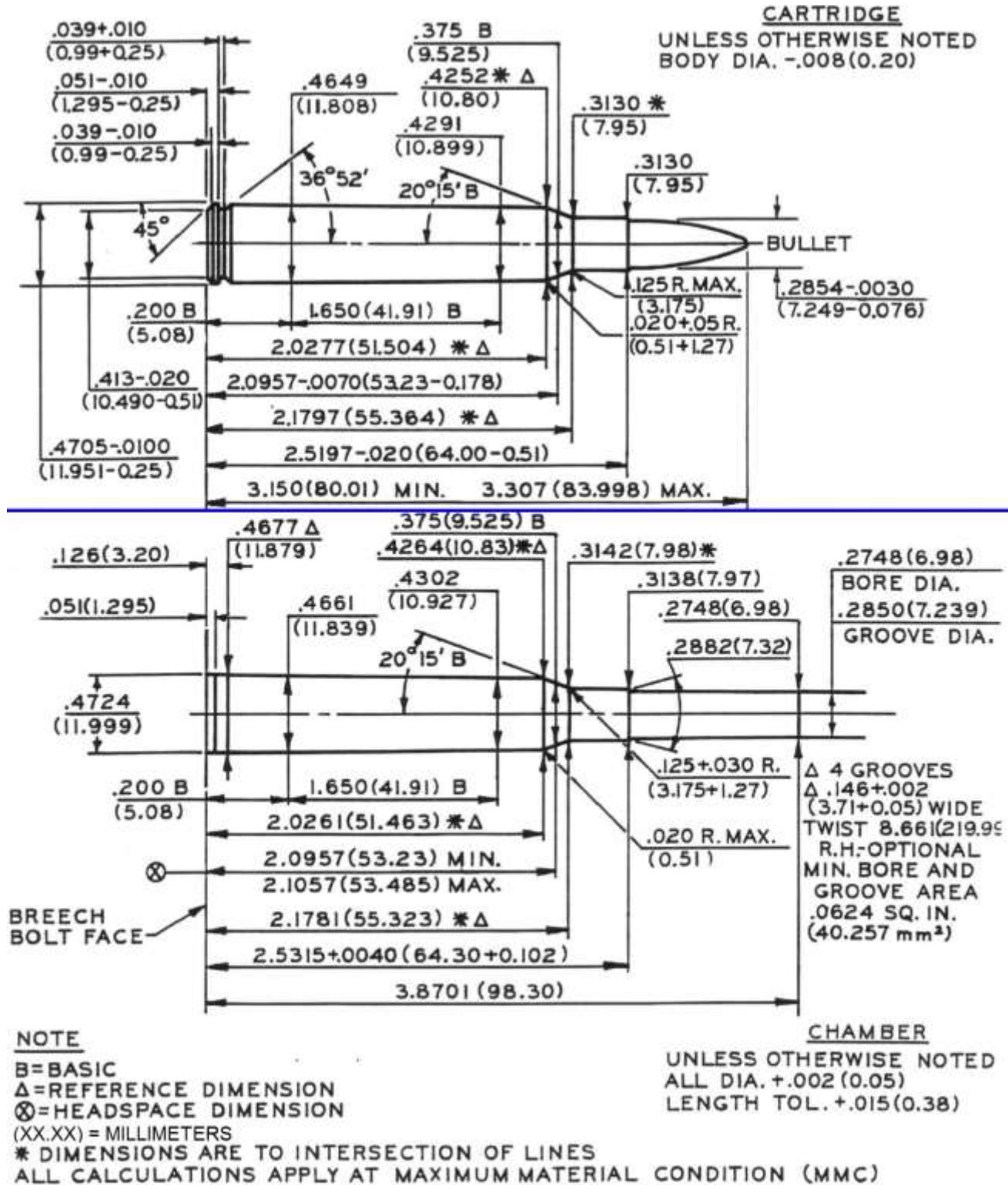

7X64 BRENEKE

NOTICE: This drawing is subject to change.
 Current version is available at www.saami.org.

MAXIMUM CARTRIDGE / MINIMUM CHAMBER

7-30 WATERS

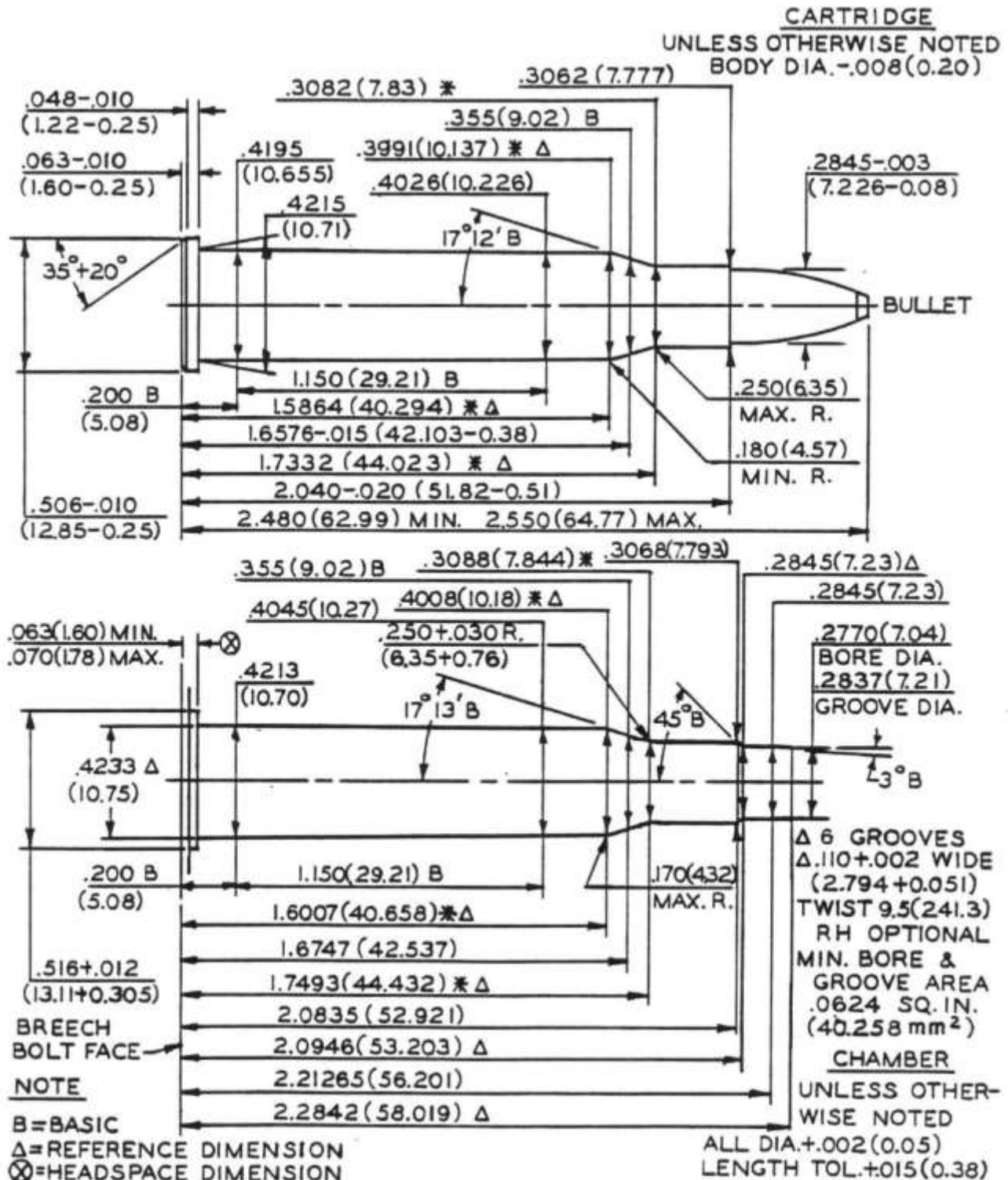

NOTICE: This drawing is subject to change.
 Current version is available at www.saami.org.

MAXIMUM CARTRIDGE / MINIMUM CHAMBER

7.62x39

Rev. 01/12/1994

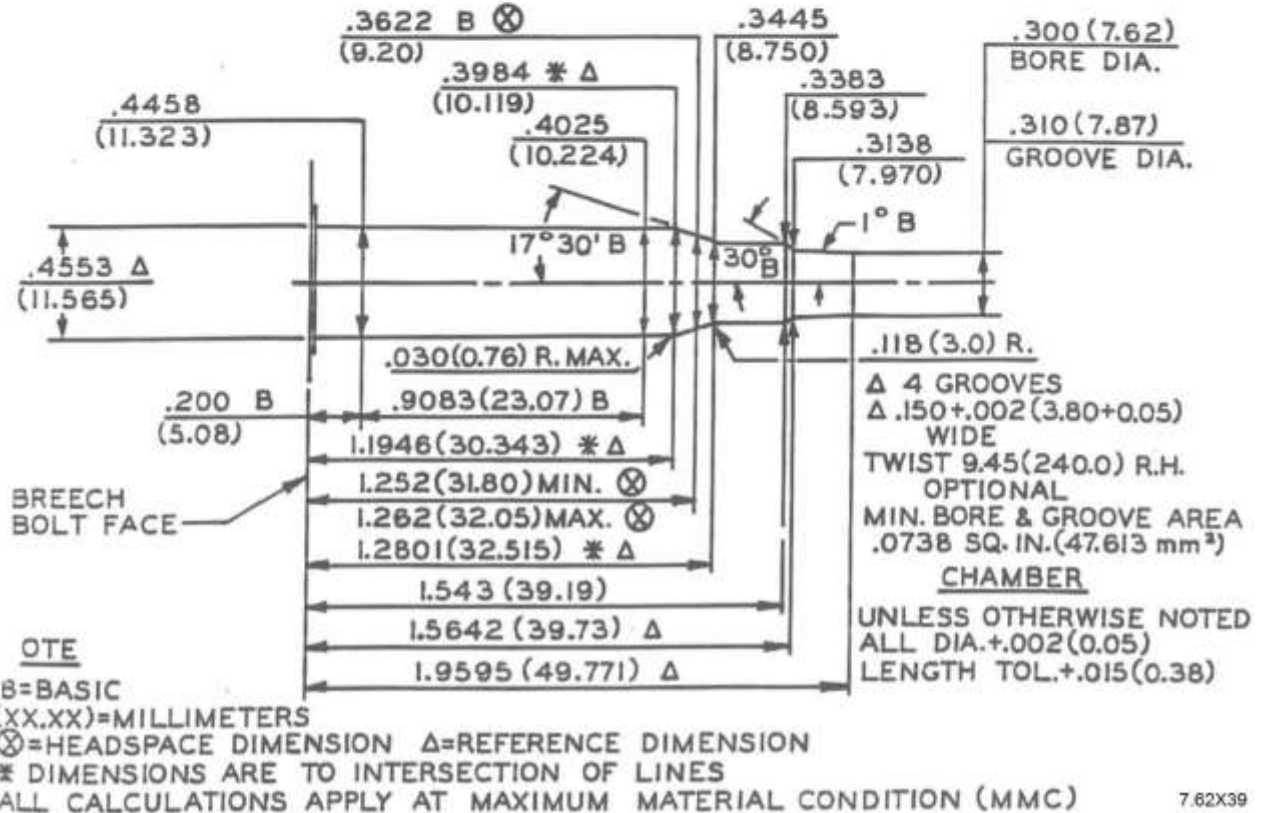
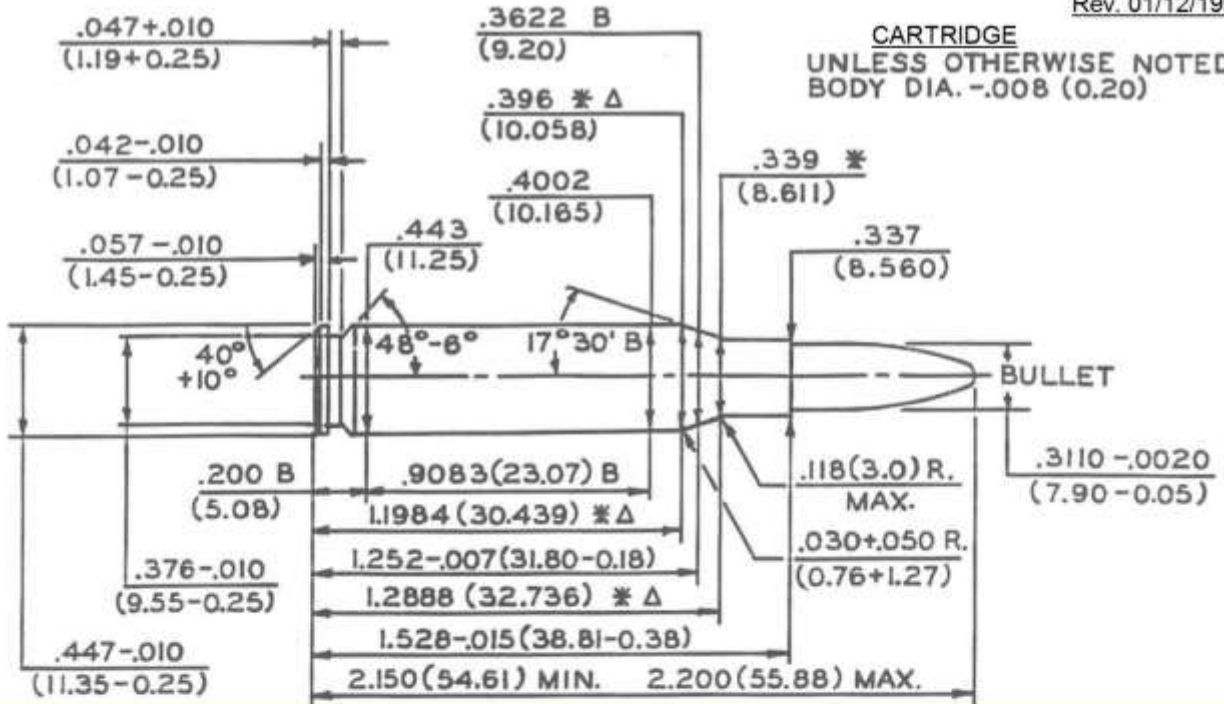

7.62X39

Note: This drawing is subject to change.
 Current version is available at www.saami.org.

MAXIMUM CARTRIDGE / MINIMUM CHAMBER

8MM MAUSER (8x57)

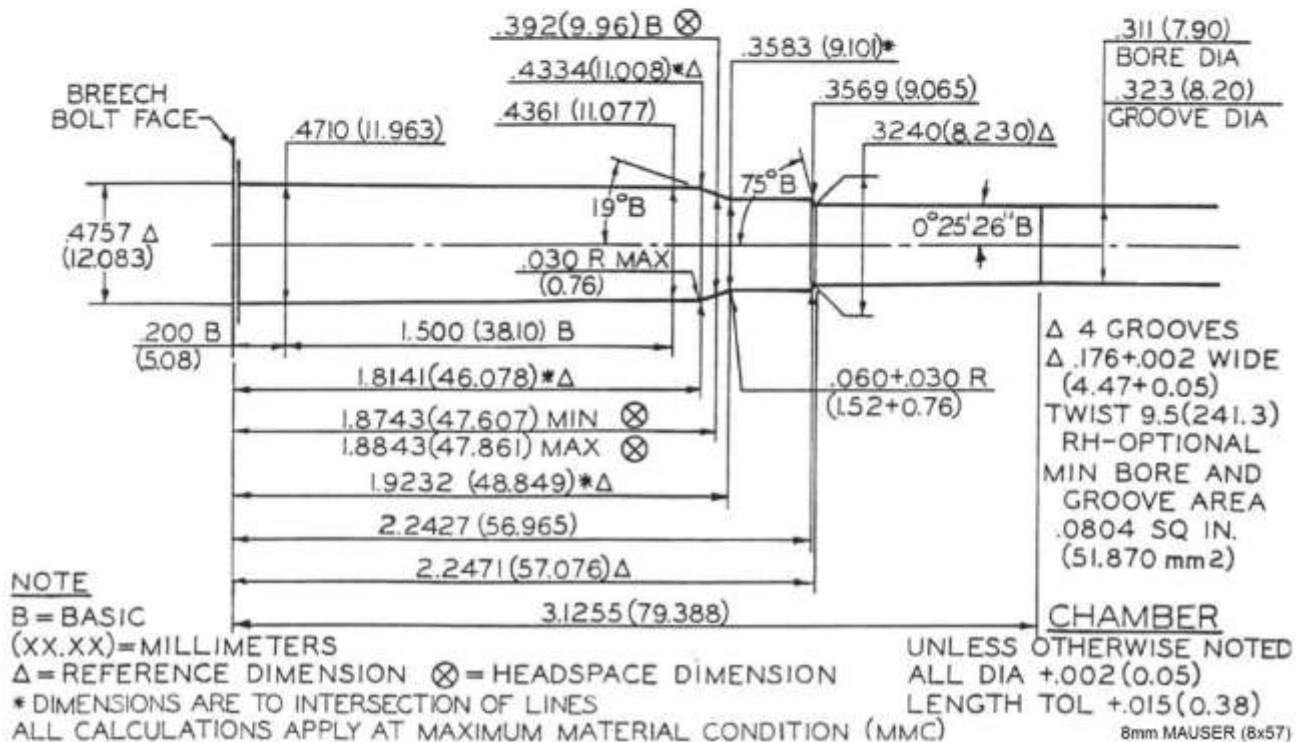
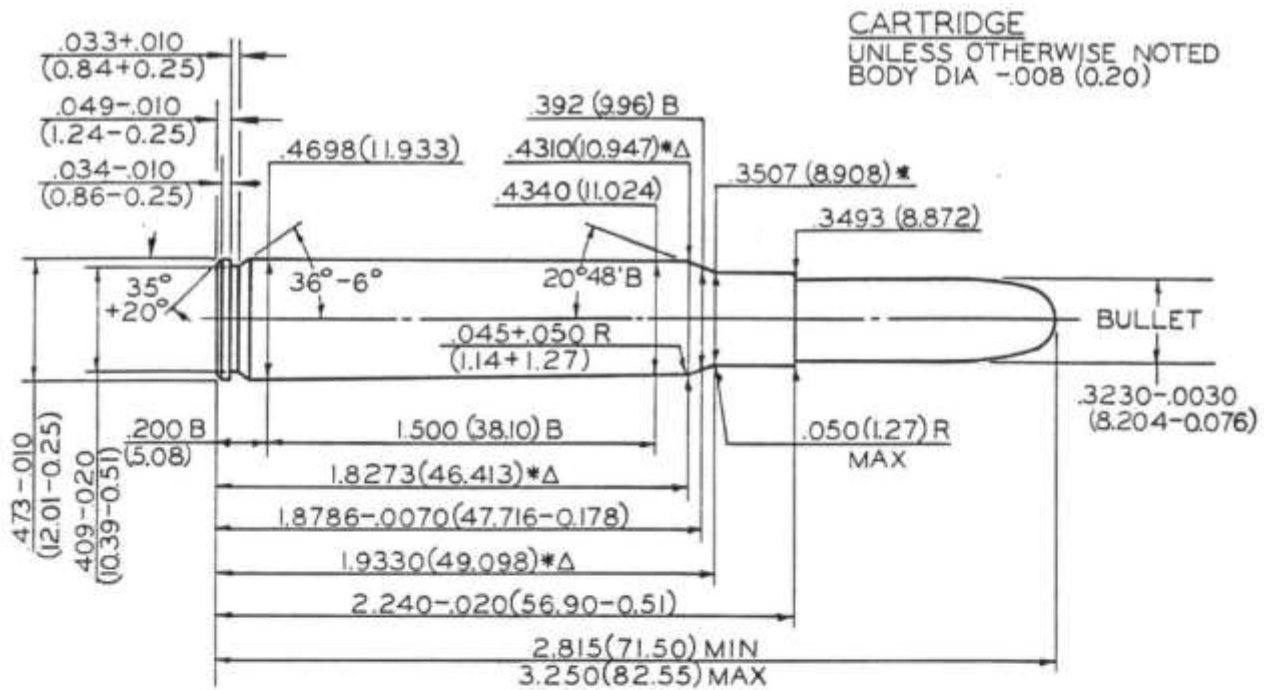

NOTICE: This drawing is subject to change.
 Current version is available at www.saami.org.

MAXIMUM CARTRIDGE / MINIMUM CHAMBER

8MM REMINGTON MAGNUM

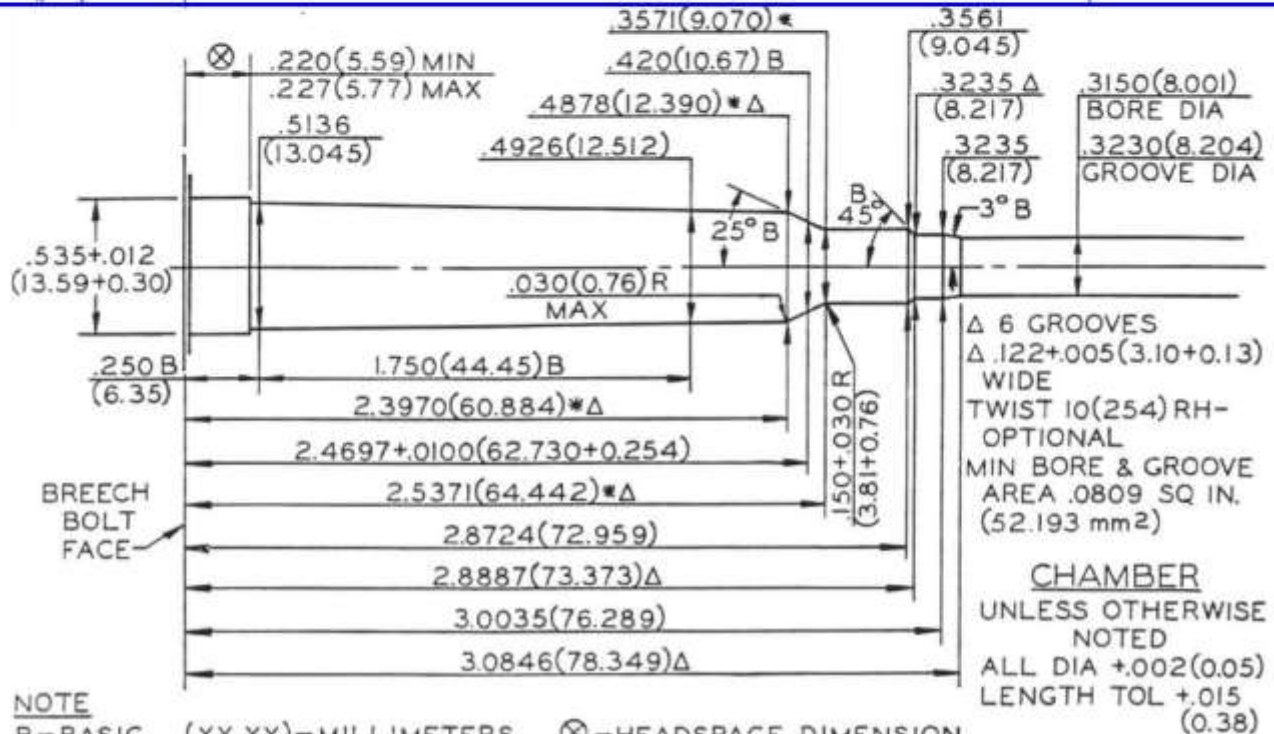
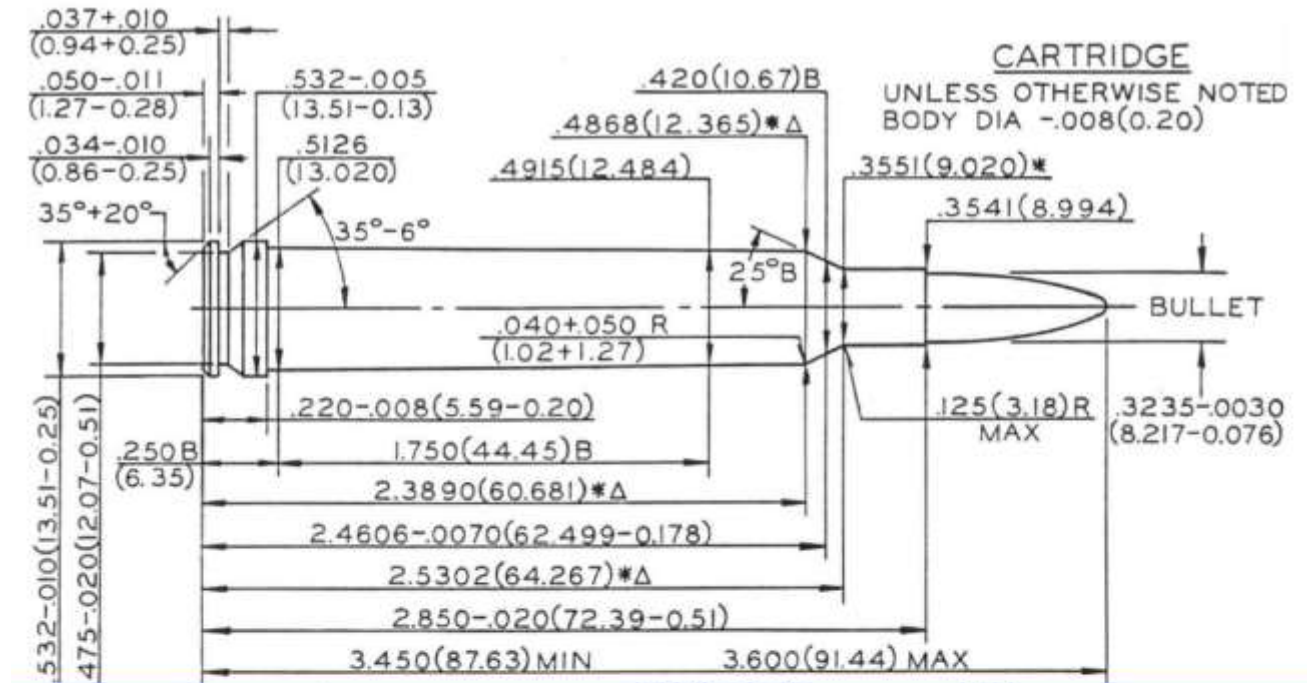

NOTE

B=BASIC (XX.XX)=MILLIMETERS ⊗=HEADSPACE DIMENSION
 * DIMENSIONS ARE TO INTERSECTION OF LINES Δ=REFERENCE DIMENSION
 ALL CALCULATIONS APPLY AT MAXIMUM MATERIAL CONDITION (MMC) 8mm REMINGTON MAGNUM

NOTICE: This drawing is subject to change.
 Current version is available at www.saami.org.

MAXIMUM CARTRIDGE / MINIMUM CHAMBER

17 HORNET

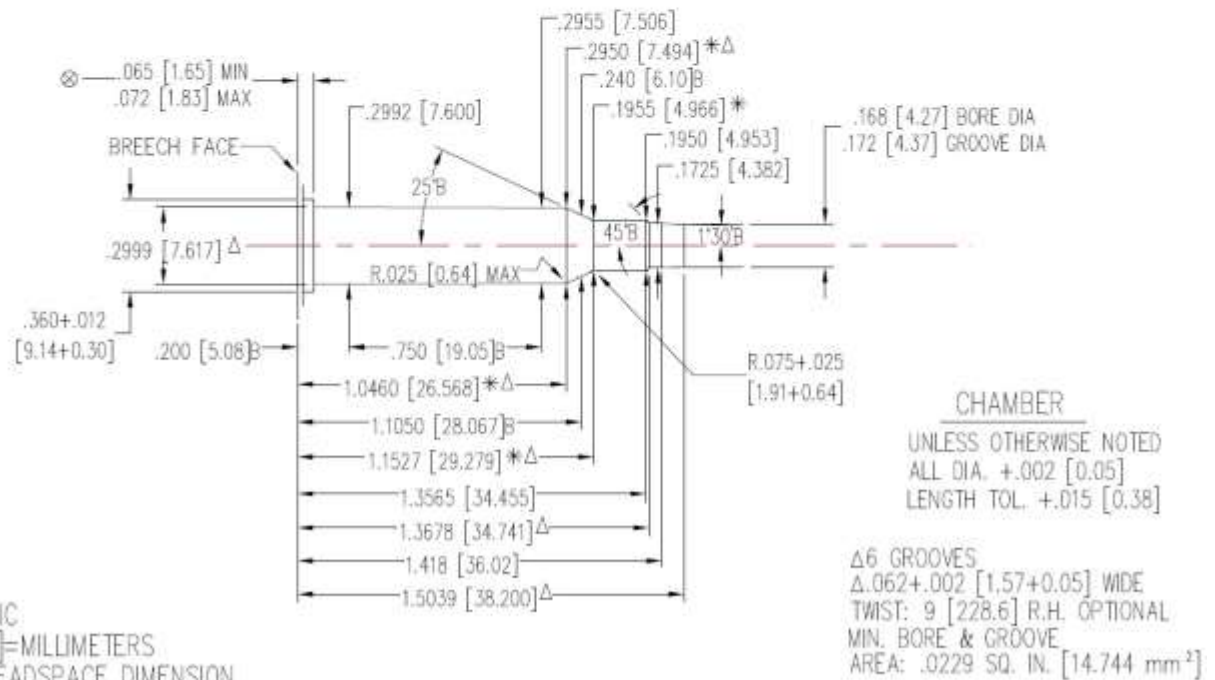
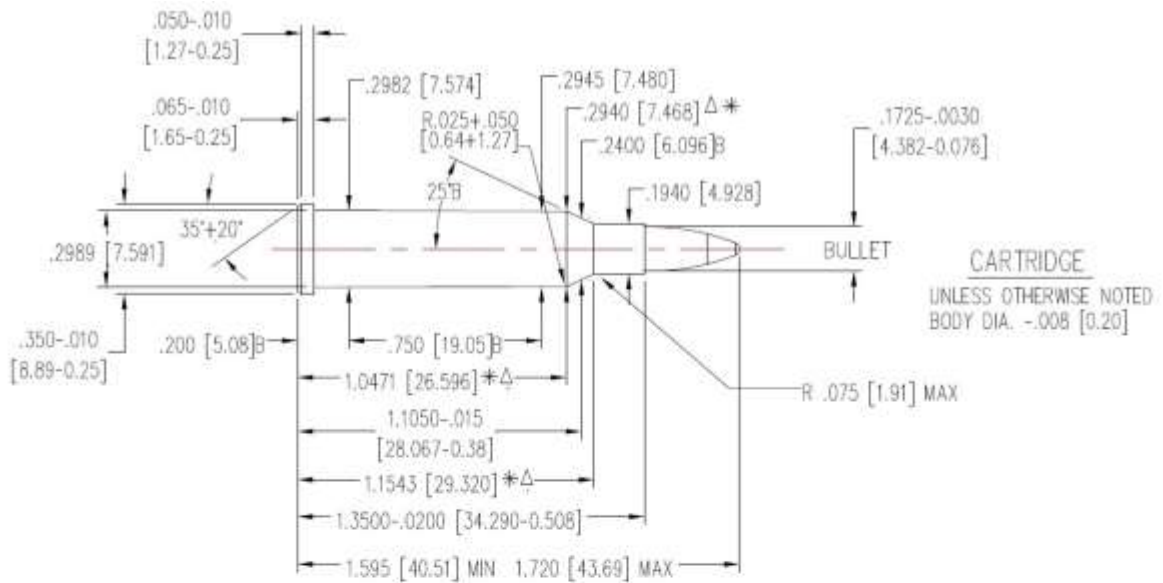

NOTE:
 β=BASIC
 [XX.XX]=MILLIMETERS
 ⊗ = HEADSPACE DIMENSION
 Δ = REFERENCE DIMENSION
 *DIMENSIONS ARE TO INTERSECTION OF LINES
 ALL CALCULATIONS APPLY AT MAXIMUM MATERIAL CONDITION (MMC)

CHAMBER
 UNLESS OTHERWISE NOTED
 ALL DIA. +.002 [0.05]
 LENGTH TOL. +.015 [0.38]
 Δ6 GROOVES
 Δ.062+.002 [1.57+0.05] WIDE
 TWIST: 9 [228.6] R.H. OPTIONAL
 MIN. BORE & GROOVE
 AREA: .0229 SQ. IN. [14.744 mm²]

17 HORNET

NOTICE: This drawing is subject to change.
 Current version is available at www.saami.org.

MAXIMUM CARTRIDGE / MINIMUM CHAMBER

17 REMINGTON

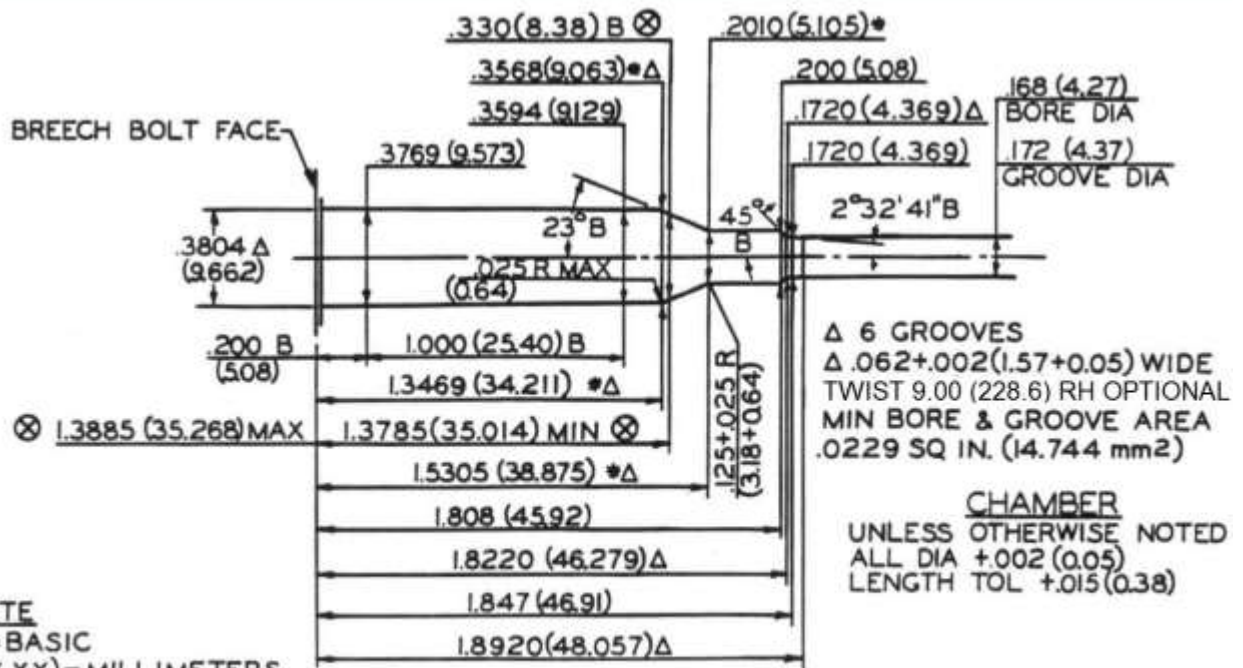
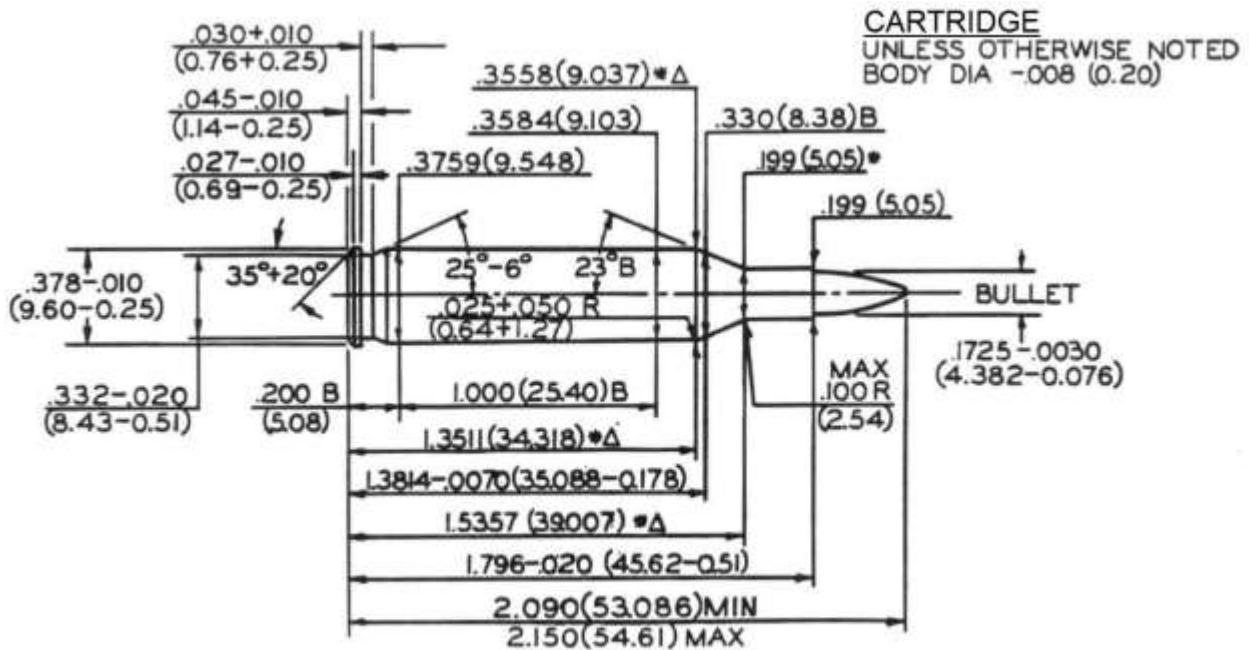

NOTE
 B = BASIC
 'XX.XX' = MILLIMETERS
 \otimes = HEADSPACE DIMENSION

* DIMENSIONS ARE TO INTERSECTION OF LINES Δ = REFERENCE DIMENSION
 ALL CALCULATIONS APPLY AT MAXIMUM MATERIAL CONDITION (MMC)

17 REMINGTON

NOTICE: This drawing is subject to change.
 Current version is available at www.saami.org.

MAXIMUM CARTRIDGE / MINIMUM CHAMBER

17 REMINGTON FIREBALL

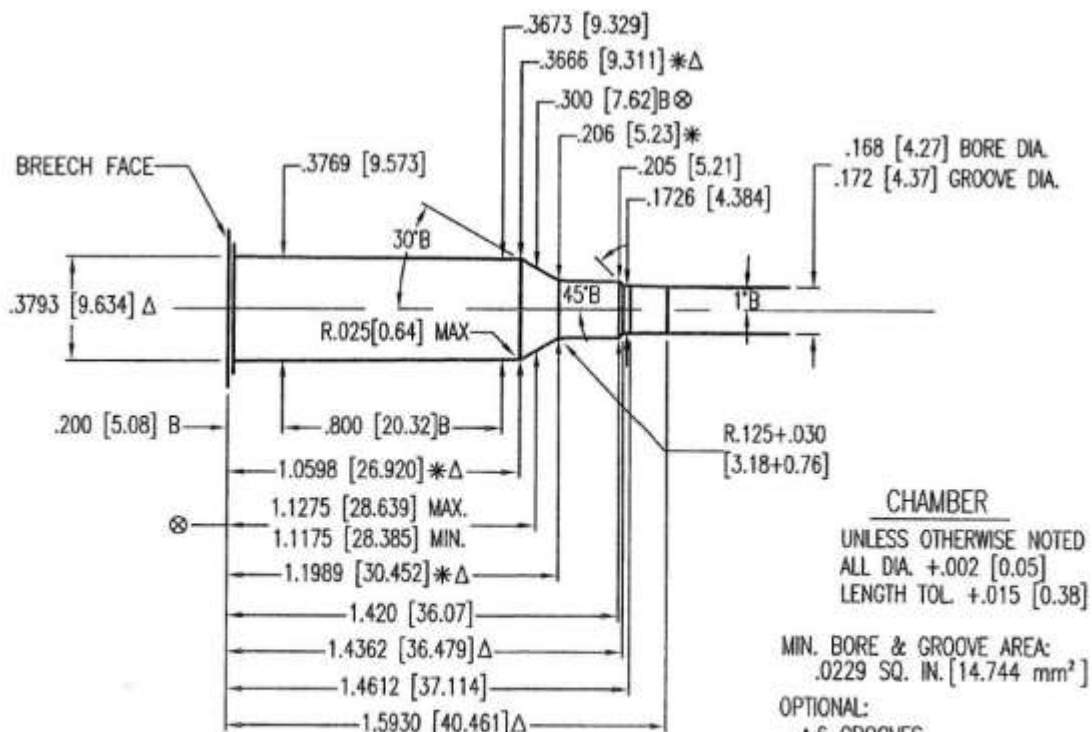
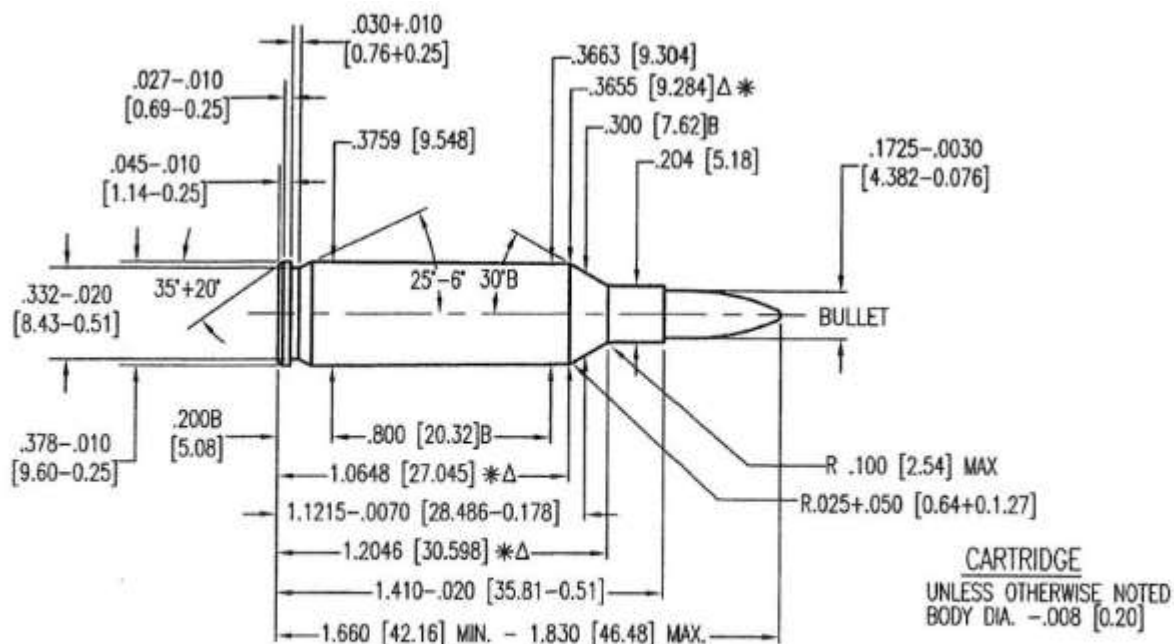

NOTE:
 B=BASIC [XX.XX]=MILLIMETERS
 ⊗ = HEADSPACE DIMENSION Δ = REFERENCE DIMENSION
 * DIMENSIONS ARE TO INTERSECTION OF LINES
 ALL CALCULATIONS APPLY AT MAXIMUM MATERIAL CONDITION (MMC)

17 REMINGTON FIREBALL

NOTICE: This drawing is subject to change.
 Current version is available at www.saami.org.

MAXIMUM CARTRIDGE / MINIMUM CHAMBER

204 RUGER

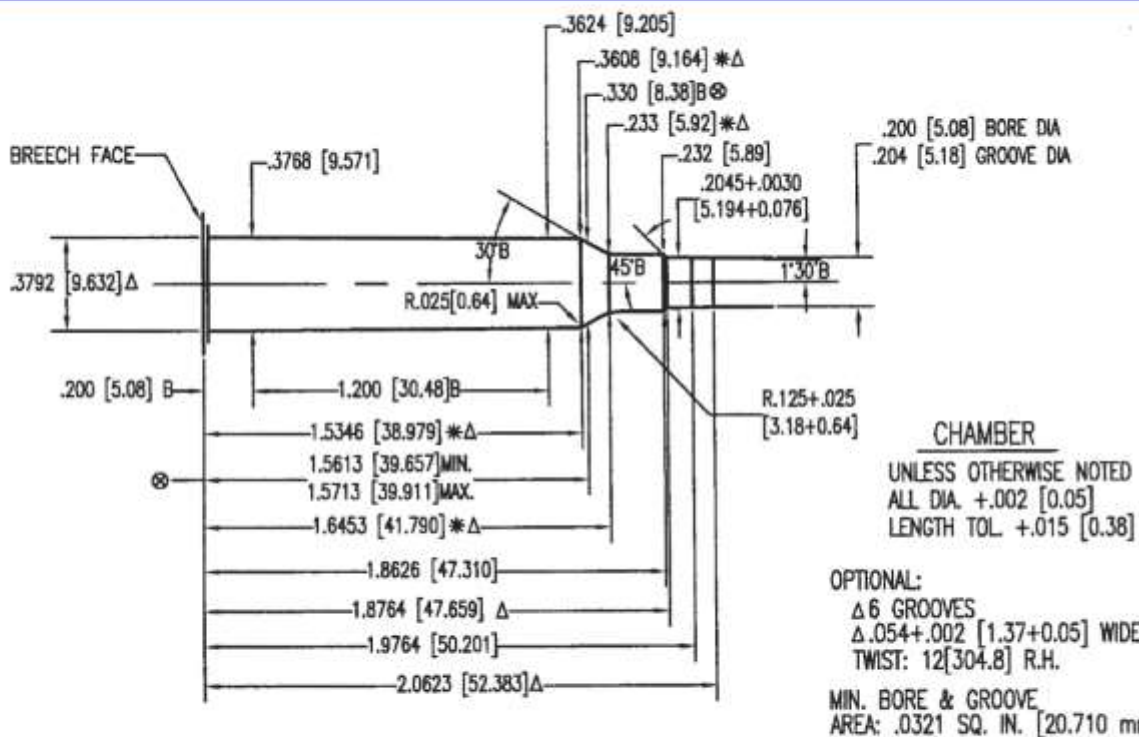
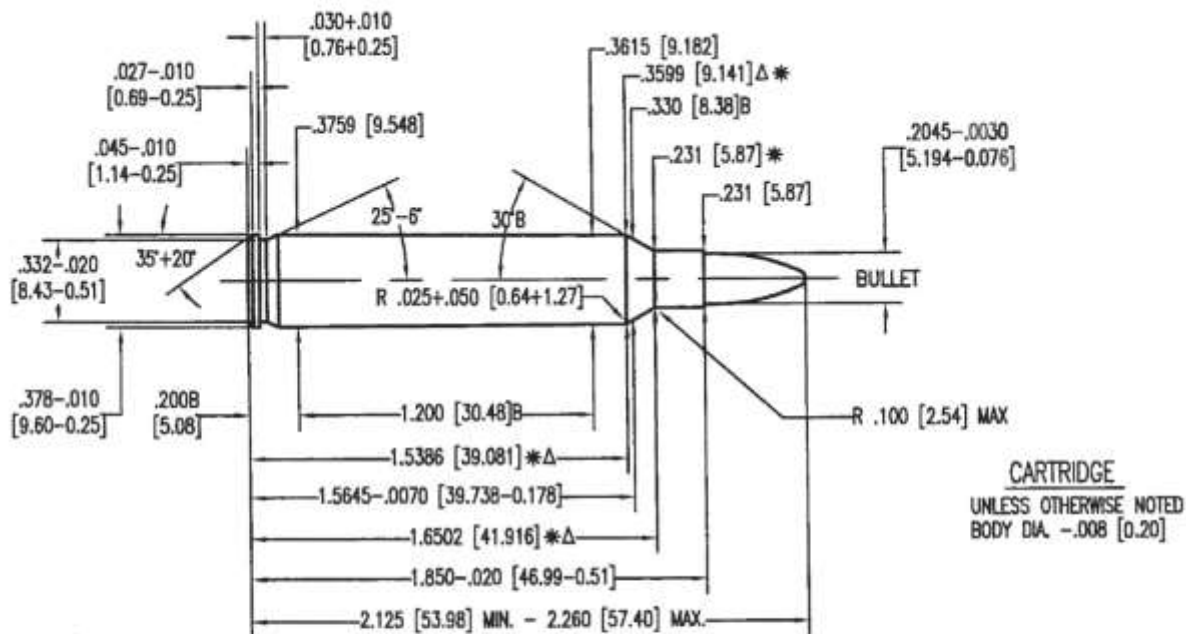

OPTIONAL:
 Δ 6 GROOVES
 Δ .054+.002 [1.37+0.05] WIDE
 TWIST: 12 [304.8] R.H.
 MIN. BORE & GROOVE
 AREA: .0321 SQ. IN. [20.710 mm²]

NOTE:
 B=BASIC
 [XX.XX]=MILLIMETERS
 ⊗ = HEADSPACE DIMENSION
 Δ = REFERENCE DIMENSION
 * DIMENSIONS ARE TO INTERSECTION OF LINES
 ALL CALCULATIONS APPLY AT MAXIMUM MATERIAL CONDITION (MMC)

NOTICE: This drawing is subject to change.
 Current version is available at www.saami.org.

MAXIMUM CARTRIDGE / MINIMUM CHAMBER

218 BEE

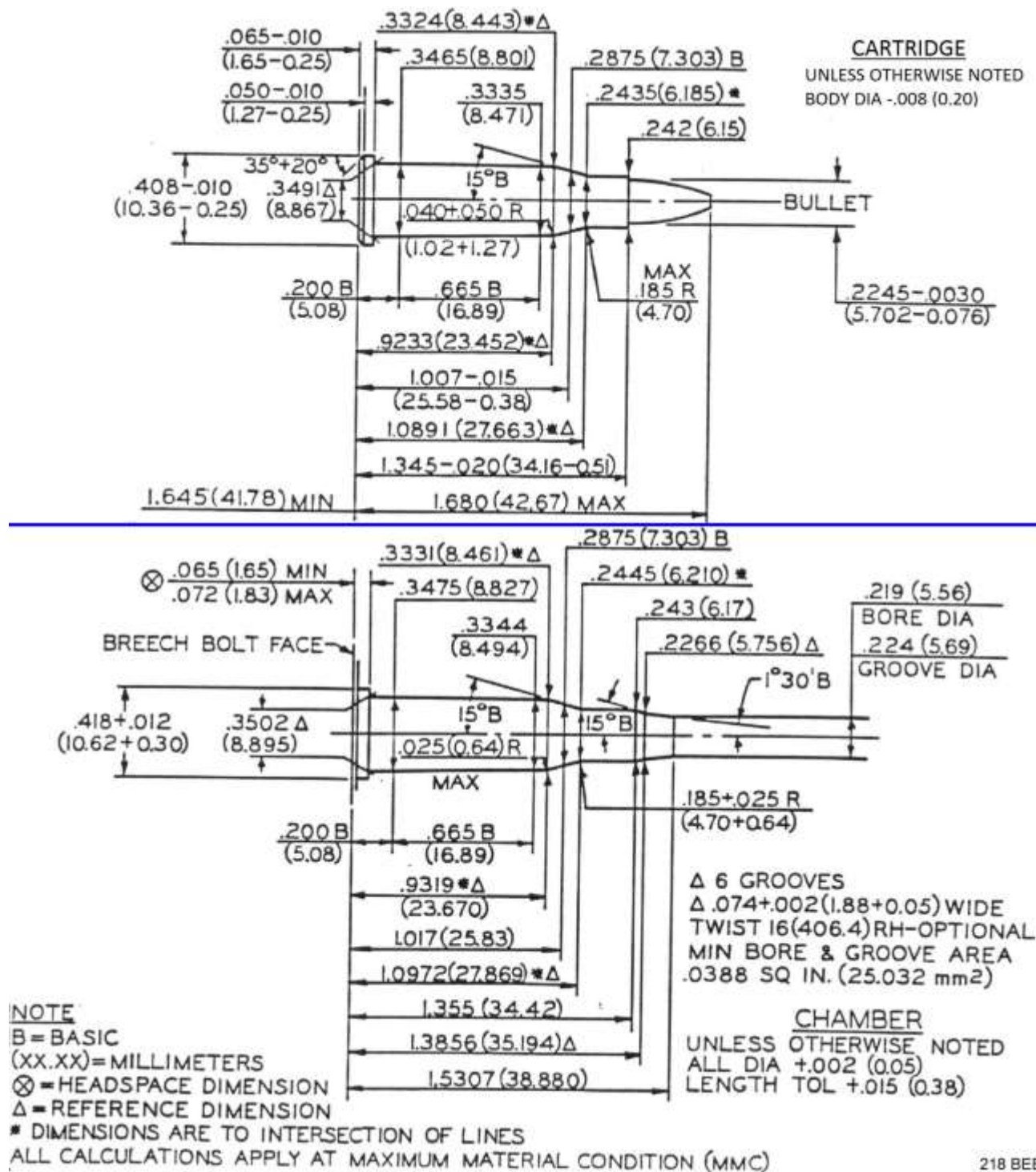

NOTICE: This drawing is subject to change.
 Current version is available at www.saami.org.

MAXIMUM CARTRIDGE / MINIMUM CHAMBER

22 HORNET

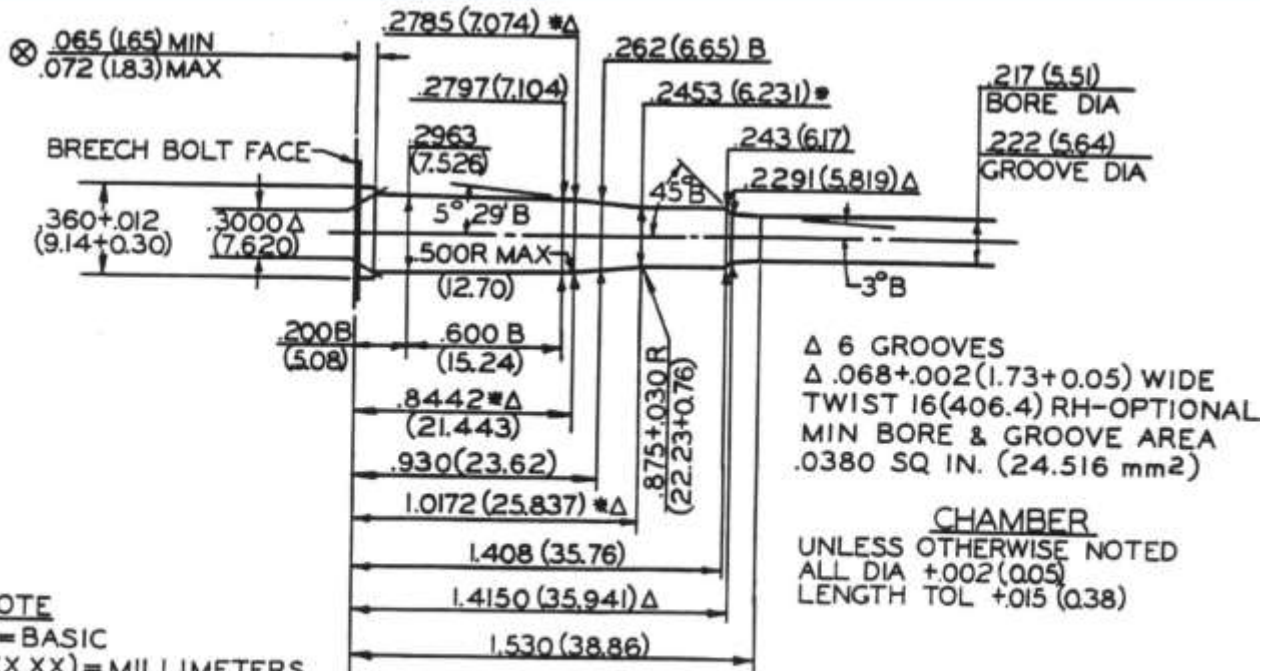
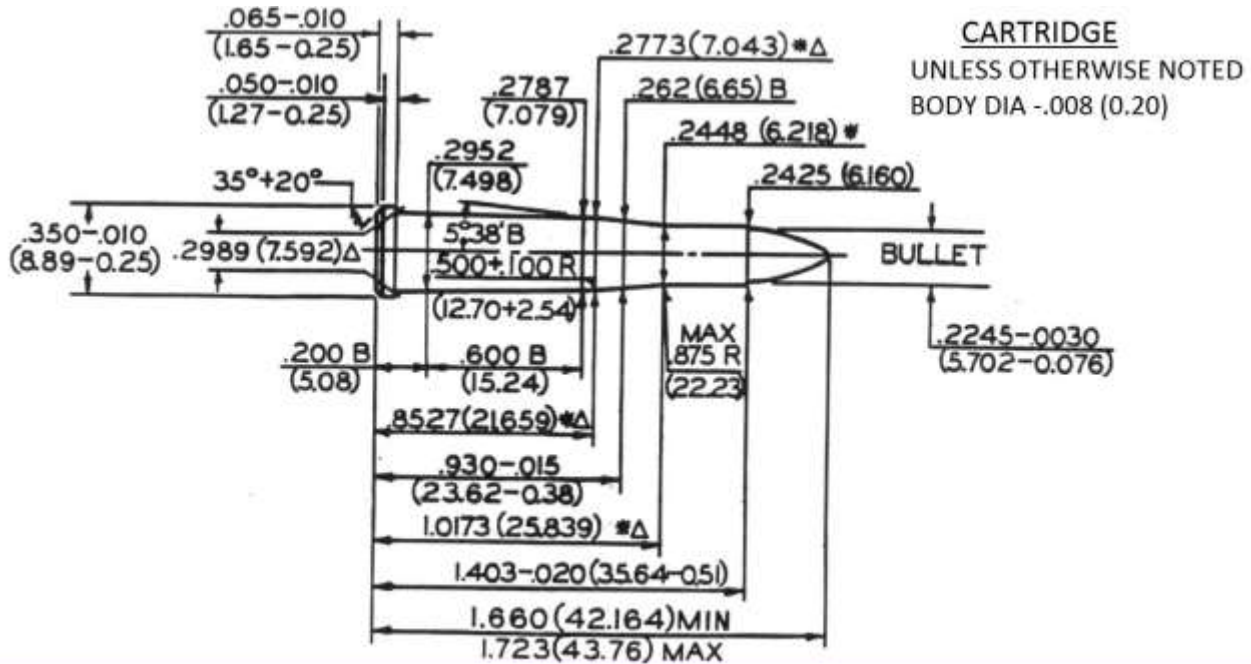

NOTE
 B = BASIC
 (XX.XX) = MILLIMETERS
 ⊗ = HEADSPACE DIMENSION

* DIMENSIONS ARE TO INTERSECTION OF LINES Δ = REFERENCE DIMENSION
 ALL CALCULATIONS APPLY AT MAXIMUM MATERIAL CONDITION (MMC)

22 HORNET

NOTICE: This drawing is subject to change.
 Current version is available at www.saami.org.

MAXIMUM CARTRIDGE / MINIMUM CHAMBER

22-250 REMINGTON

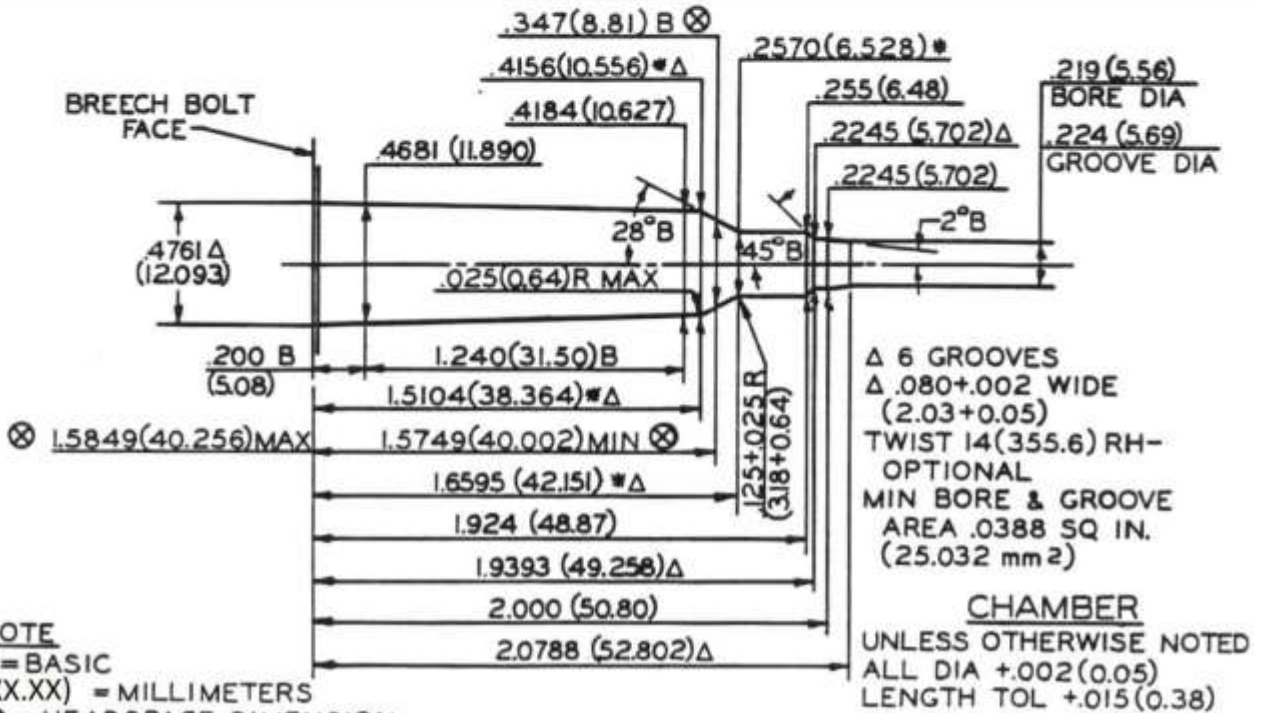
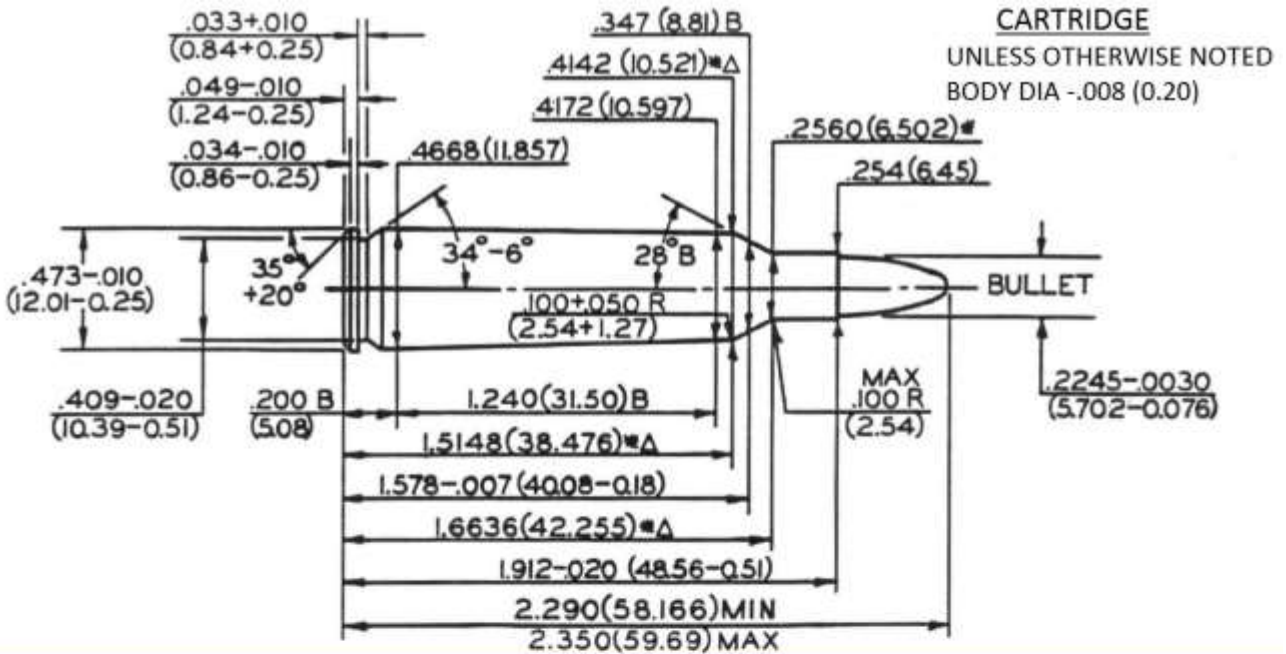

NOTE

B = BASIC
 (XX.XX) = MILLIMETERS

⊗ = HEADSPACE DIMENSION

* DIMENSIONS ARE TO INTERSECTION OF LINES

Δ = REFERENCE DIMENSION

ALL CALCULATIONS APPLY AT MAXIMUM MATERIAL CONDITION (MMC)

22-250 REMINGTON

NOTICE: This drawing is subject to change.
 Current version is available at www.saami.org.

MAXIMUM CARTRIDGE / MINIMUM CHAMBER

220 SWIFT

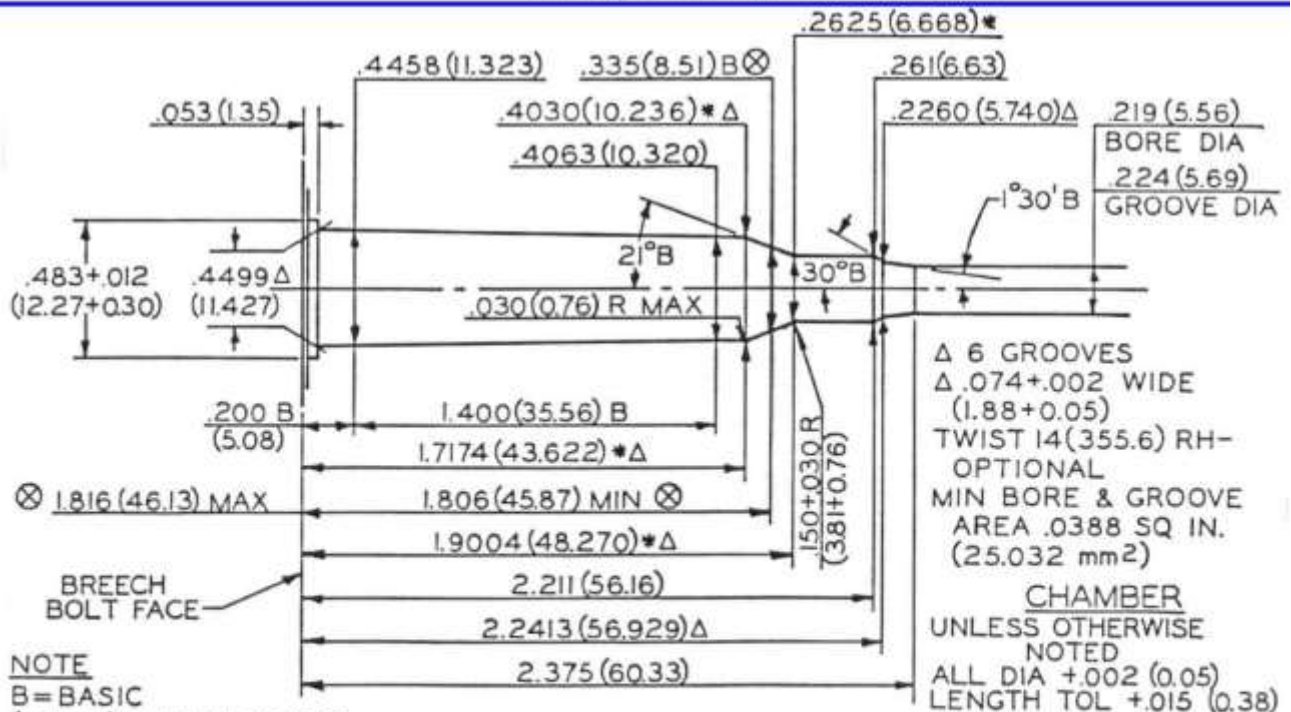
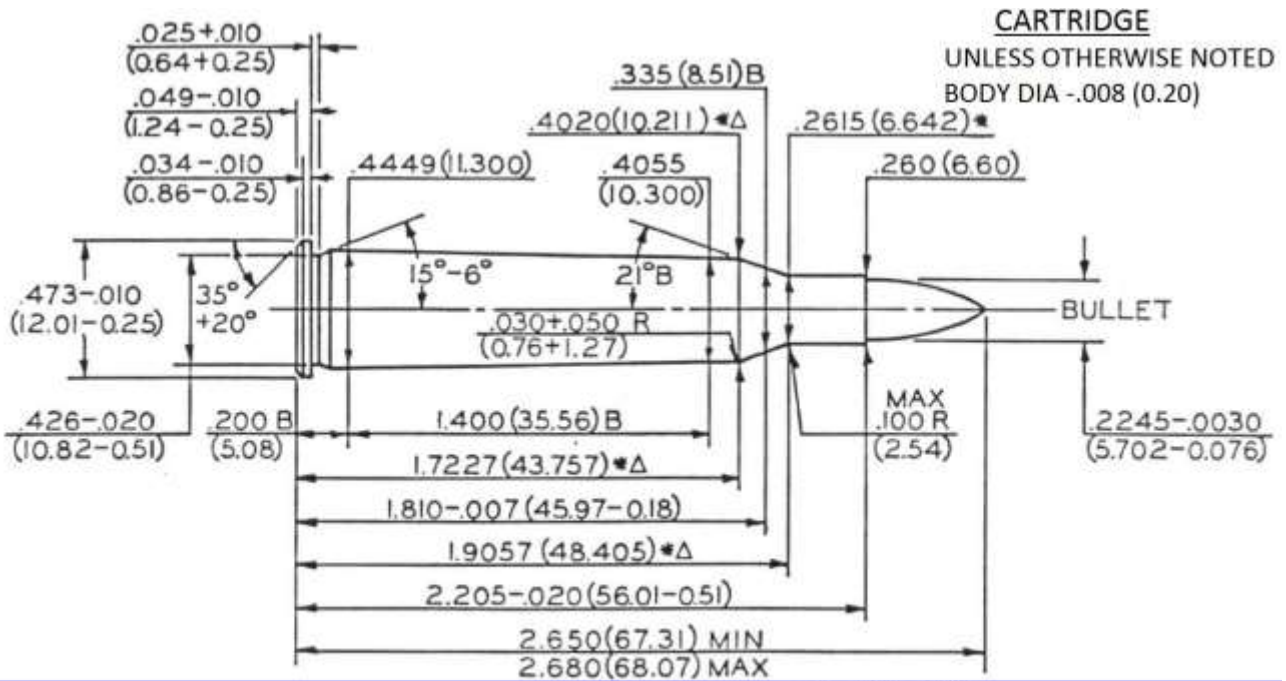

NOTE

B = BASIC

(XX.XX) = MILLIMETERS

⊗ = HEADSPACE DIMENSION

* DIMENSIONS ARE TO INTERSECTION OF LINES

Δ = REFERENCE DIMENSION

ALL CALCULATIONS APPLY AT MAXIMUM MATERIAL CONDITION (MMC)

220 SWIFT

NOTICE: This drawing is subject to change.
 Current version is available at www.saami.org.

MAXIMUM CARTRIDGE / MINIMUM CHAMBER

221 REMINGTON FIREBALL

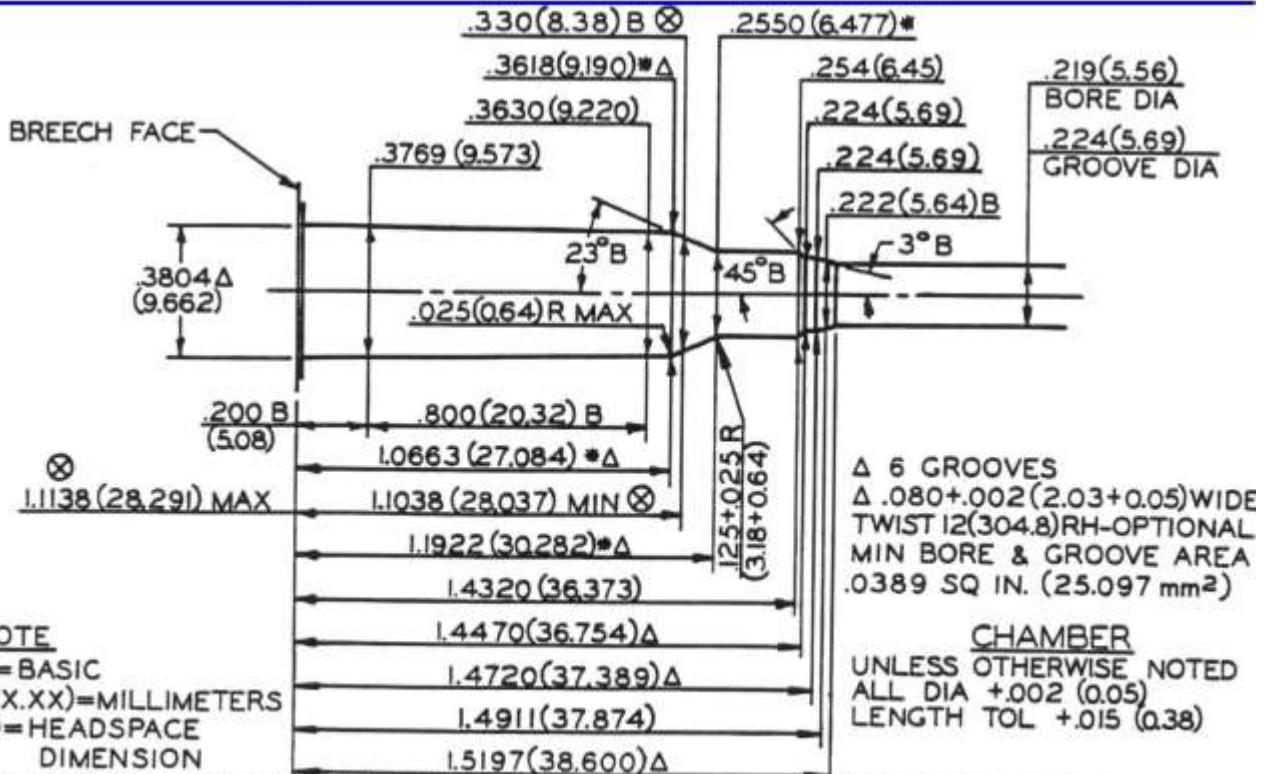
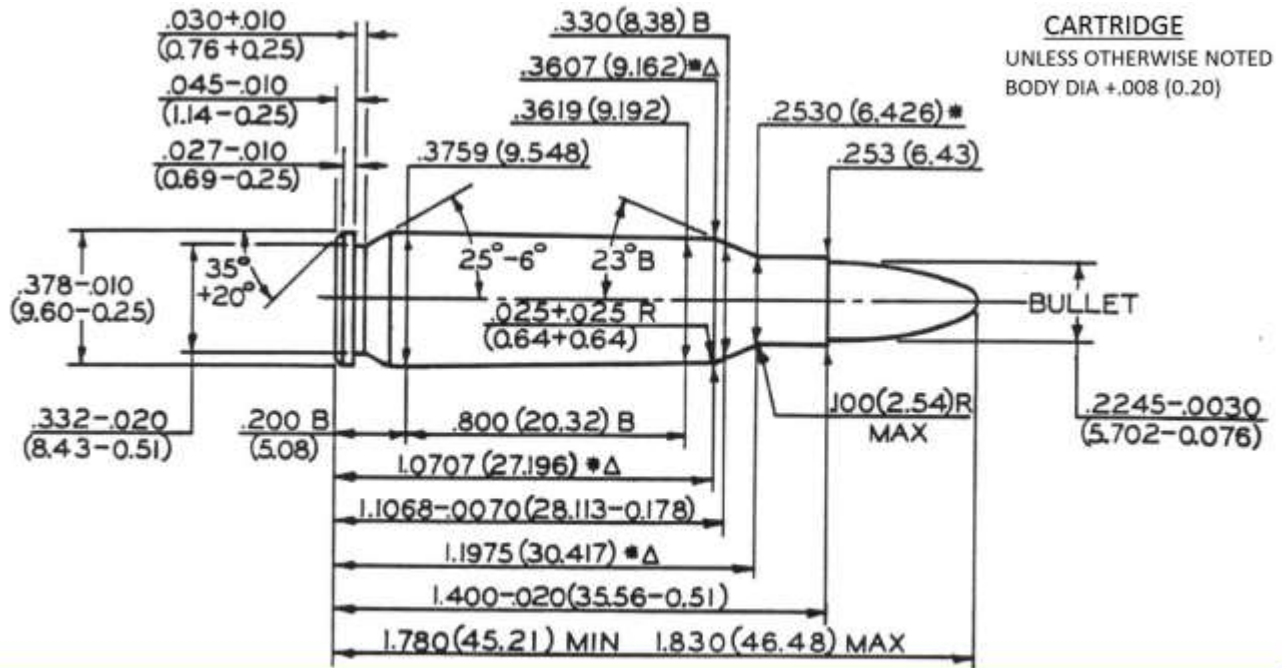

ALL CALCULATIONS APPLY AT MAXIMUM MATERIAL CONDITION (MMC) 221 REMINGTON FIREBALL

NOTICE: This drawing is subject to change.
 Current version is available at www.saami.org.

MAXIMUM CARTRIDGE / MINIMUM CHAMBER

222 REMINGTON

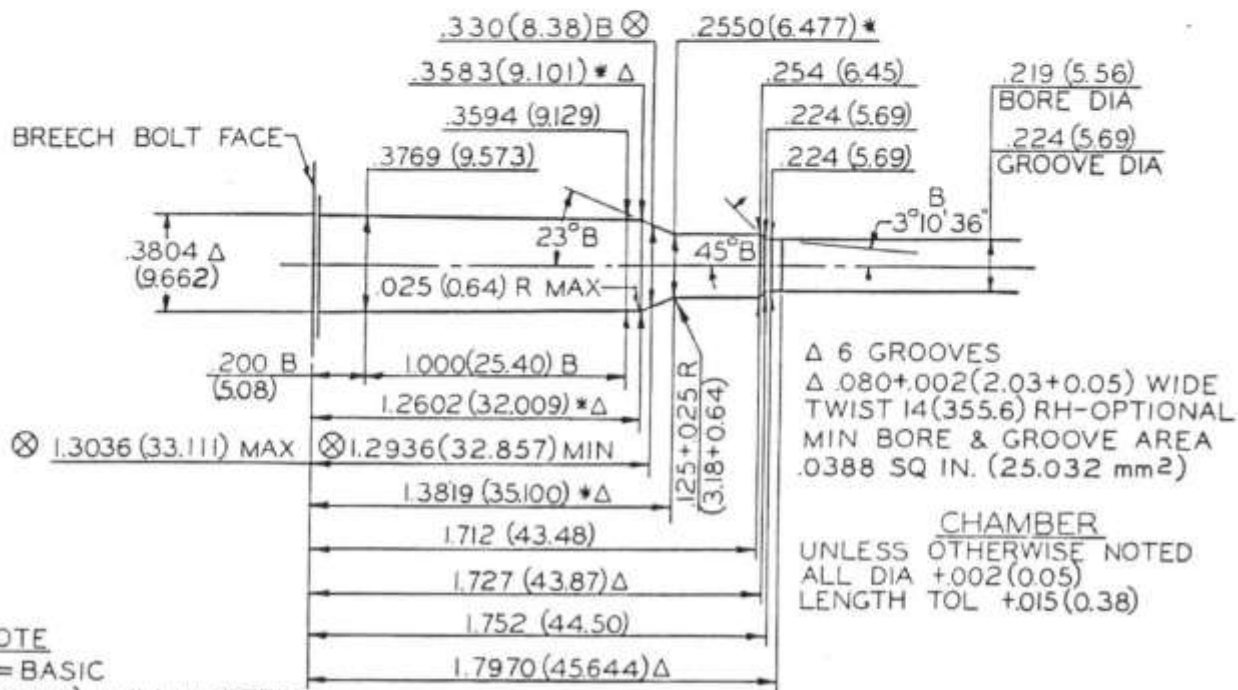
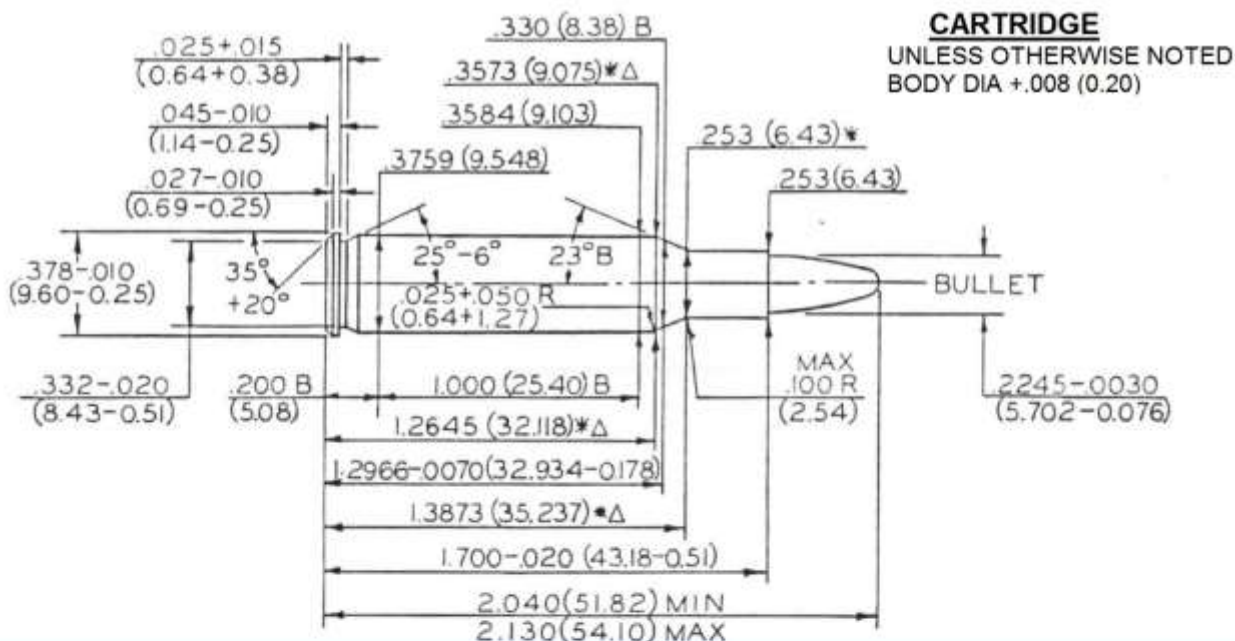

NOTE

B = BASIC
 (XX.XX) = MILLIMETERS

⊗ = HEADSPACE DIMENSION

* DIMENSIONS ARE TO INTERSECTION OF LINES Δ = REFERENCE DIMENSION
 ALL CALCULATIONS APPLY AT MAXIMUM MATERIAL CONDITION (MMC)

222 REMINGTON

NOTICE: This drawing is subject to change.
 Current version is available at www.saami.org.

MAXIMUM CARTRIDGE / MINIMUM CHAMBER

222 REMINGTON MAGNUM

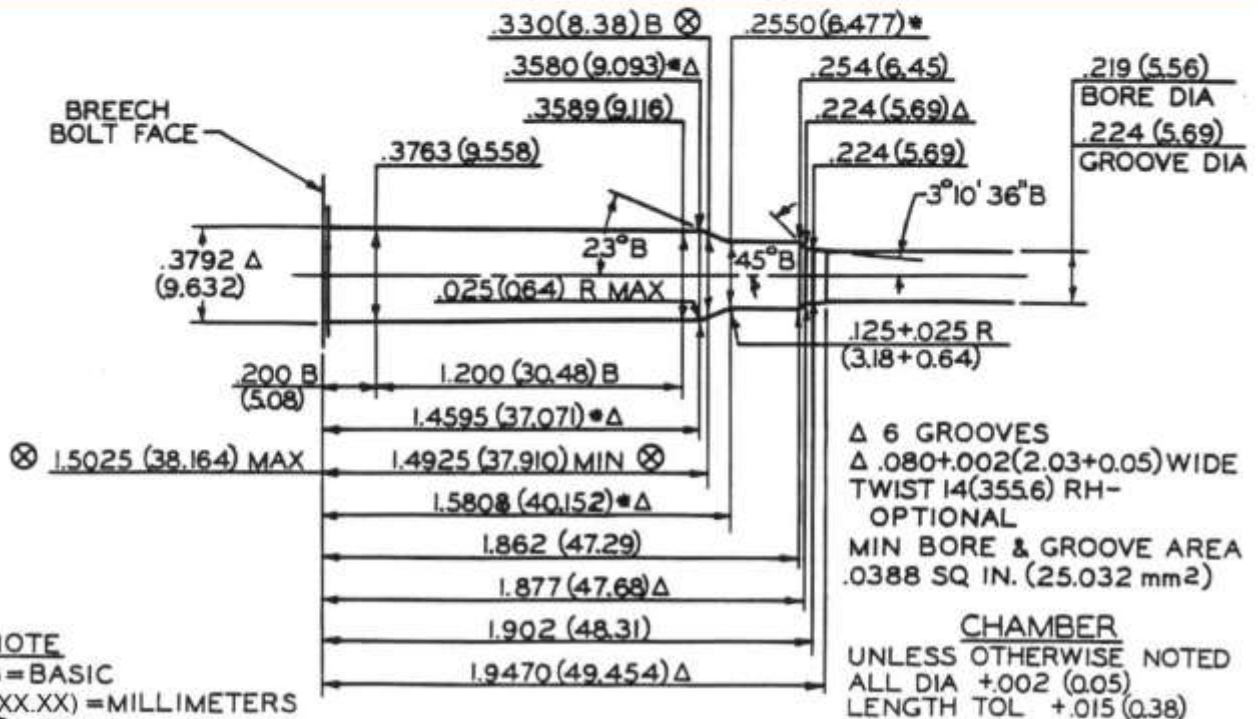
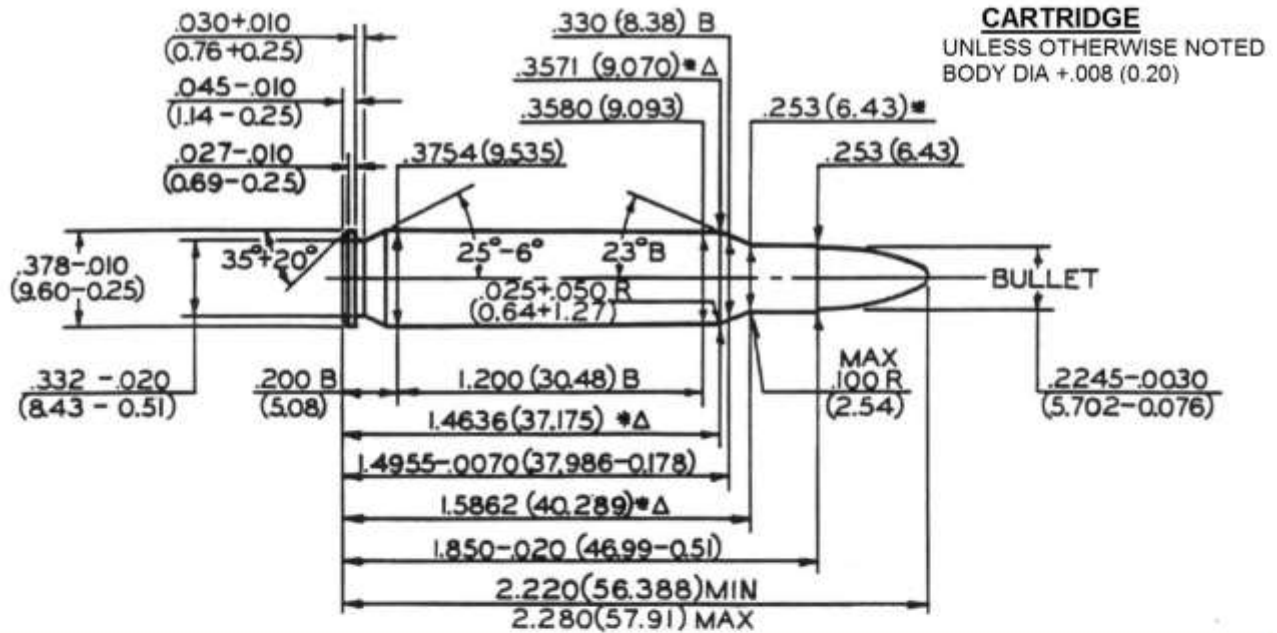

NOTE
 B=BASIC
 (XX.XX)=MILLIMETERS
 ⊗=HEADSPACE DIMENSION

* DIMENSIONS ARE TO INTERSECTION OF LINES Δ=REFERENCE DIMENSION
 ALL CALCULATIONS APPLY AT MAXIMUM MATERIAL CONDITION (MMC)

NOTICE: This drawing is subject to change.
 Current version is available at www.saami.org.

MAXIMUM CARTRIDGE / MINIMUM CHAMBER

223 REMINGTON

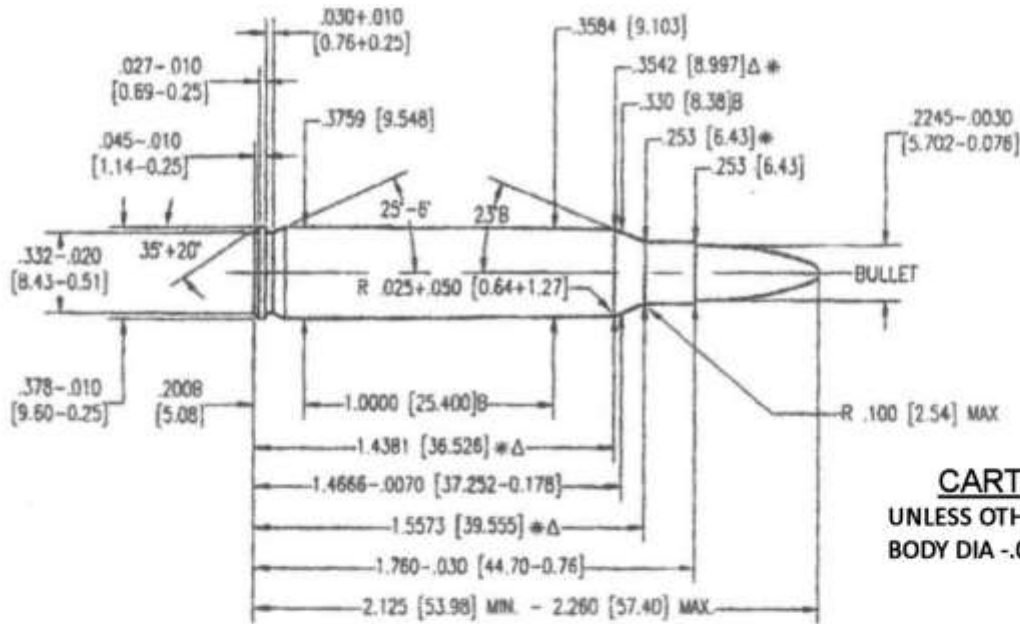

CARTRIDGE
 UNLESS OTHERWISE NOTED
 BODY DIA -.008 (0.20)

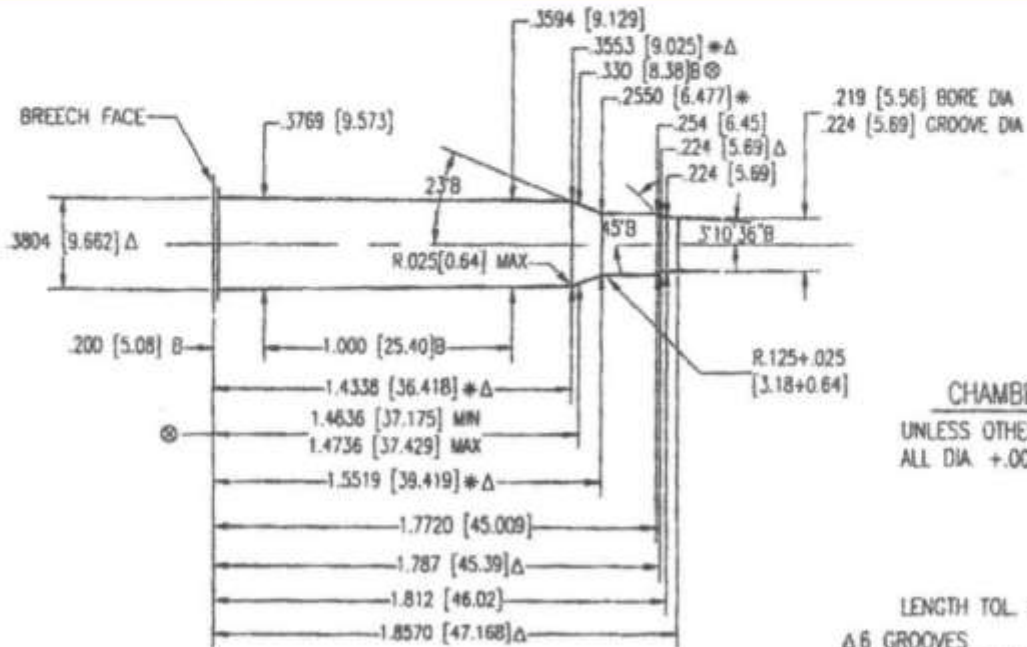

CHAMBER
 UNLESS OTHERWISE NOTED
 ALL DIA +.002 [0.05]

LENGTH TOL +.015 [0.38]

Δ 6 GROOVES
 Δ .074+.002 [1.88+0.05] WIDE
 TWIST: 12[304.8] R.H. OPTIONAL
 MIN. BORE & GROOVE
 AREA: .0388 SQ. IN. [25.032 mm²]

NOTE:
 B=BASIC
 [XX.XX]=MILLIMETERS
 ⊗ = HEADSPACE DIMENSION
 Δ = REFERENCE DIMENSION
 * DIMENSIONS ARE TO INTERSECTION OF LINES
 ALL CALCULATIONS APPLY AT MAXIMUM MATERIAL CONDITION (MMC)

223 REMINGTON

NOTICE: This drawing is subject to change.
 Current version is available at www.saami.org.

MAXIMUM CARTRIDGE / MINIMUM CHAMBER
223 WINCHESTER SUPER SHORT MAGNUM

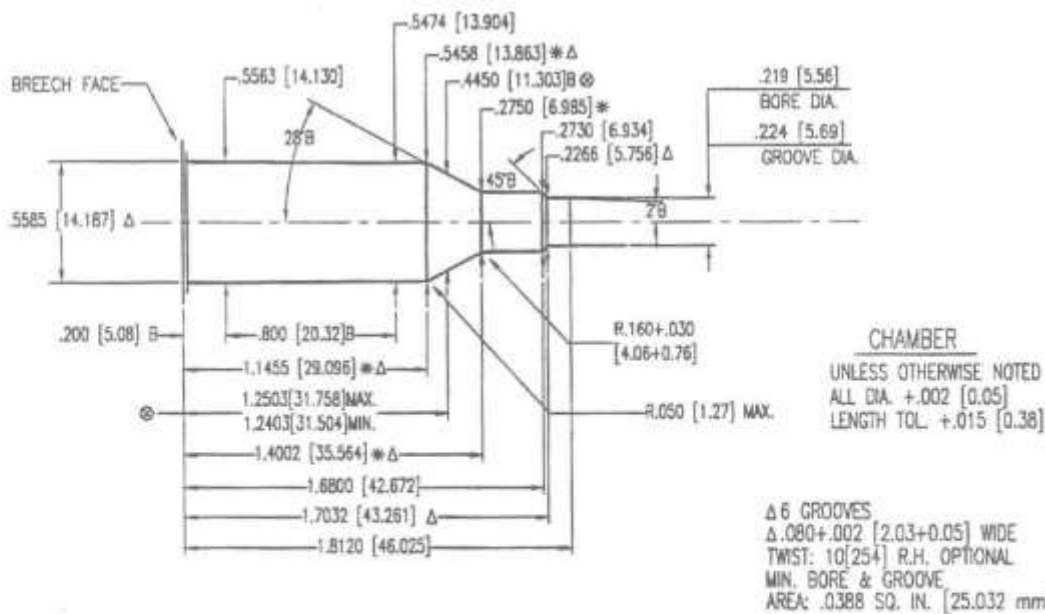
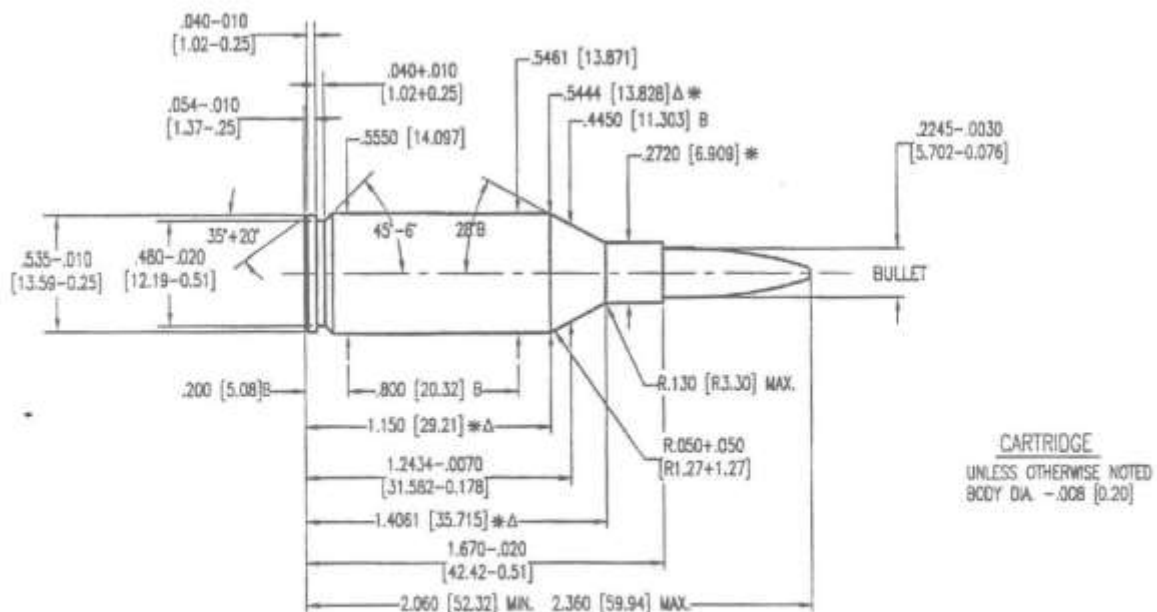

NOTE:
 B=BASIC
 [XX.XX]=MILLIMETERS
 ⊕ = HEADSPACE DIMENSION
 Δ = REFERENCE DIMENSION
 * DIMENSIONS ARE TO INTERSECTION OF LINES
 ALL CALCULATIONS APPLY AT MAXIMUM MATERIAL CONDITION (MMC)

223 WSSM

NOTICE: This drawing is subject to change.
 Current version is available at www.saami.org.

MAXIMUM CARTRIDGE / MINIMUM CHAMBER

225 WINCHESTER

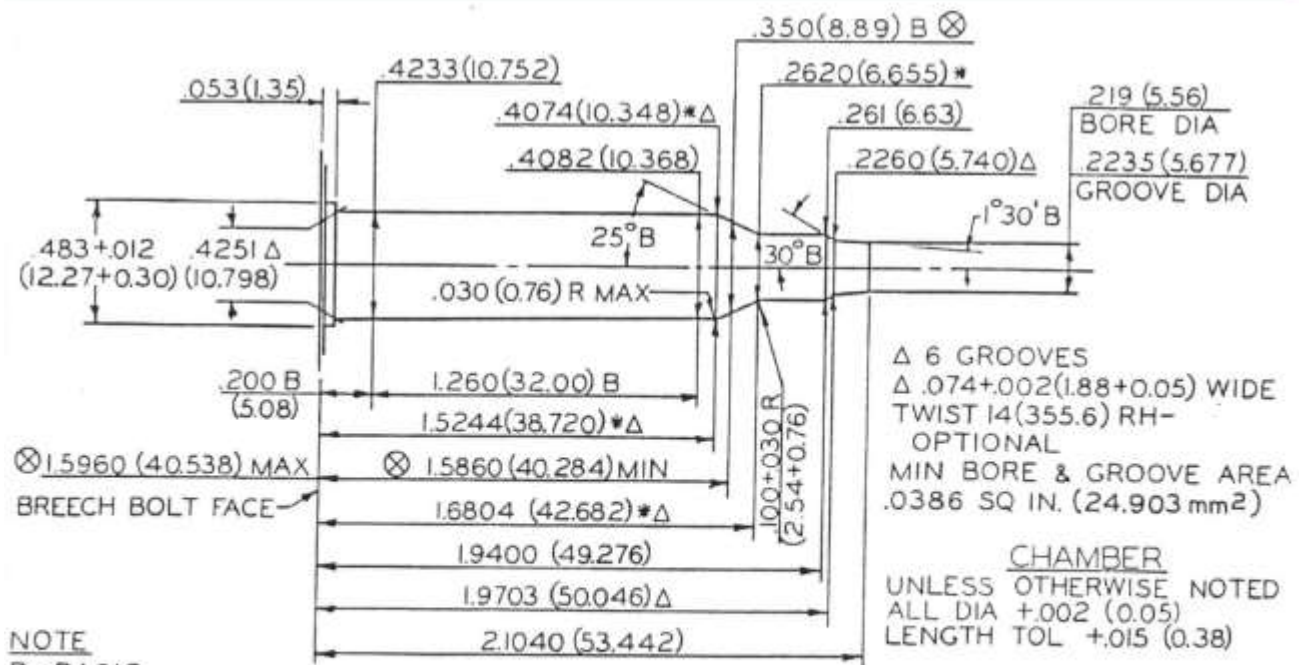
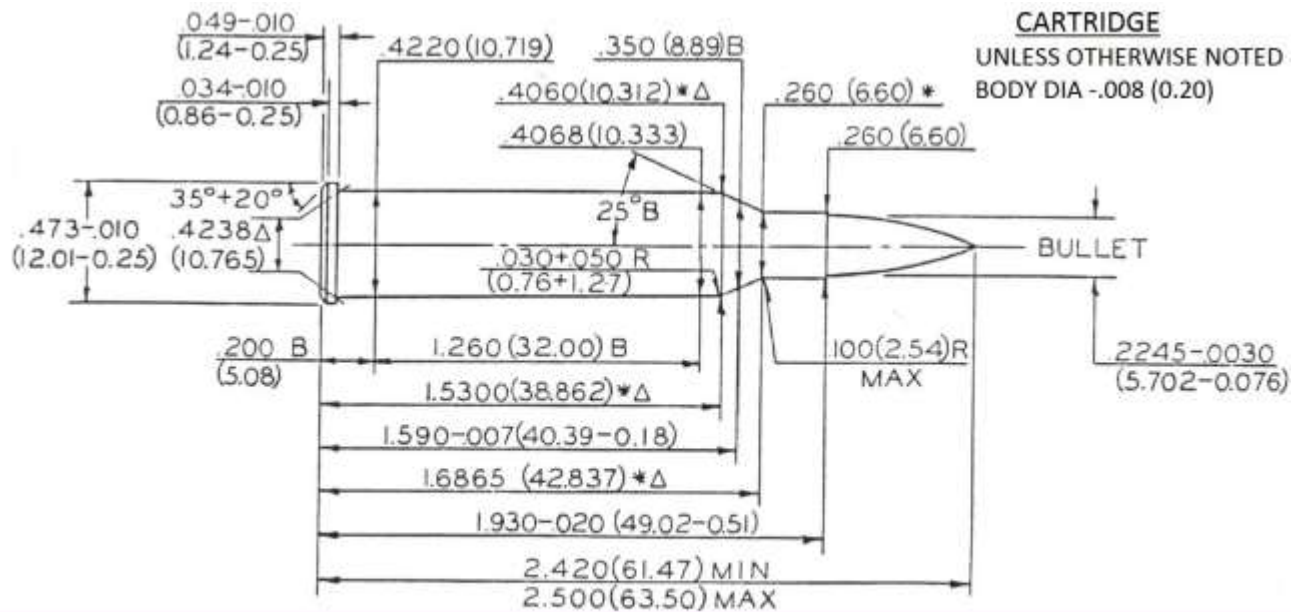

NOTE
 B=BASIC
 (XX.XX)=MILLIMETERS
 ⊗ = HEADSPACE DIMENSION
 * DIMENSIONS ARE TO INTERSECTION OF LINES
 Δ=REFERENCE DIMENSION
 ALL CALCULATIONS APPLY AT MAXIMUM MATERIAL CONDITION (MMC)

NOTICE: This drawing is subject to change.
 Current version is available at www.saami.org.

MAXIMUM CARTRIDGE / MINIMUM CHAMBER

243 WINCHESTER

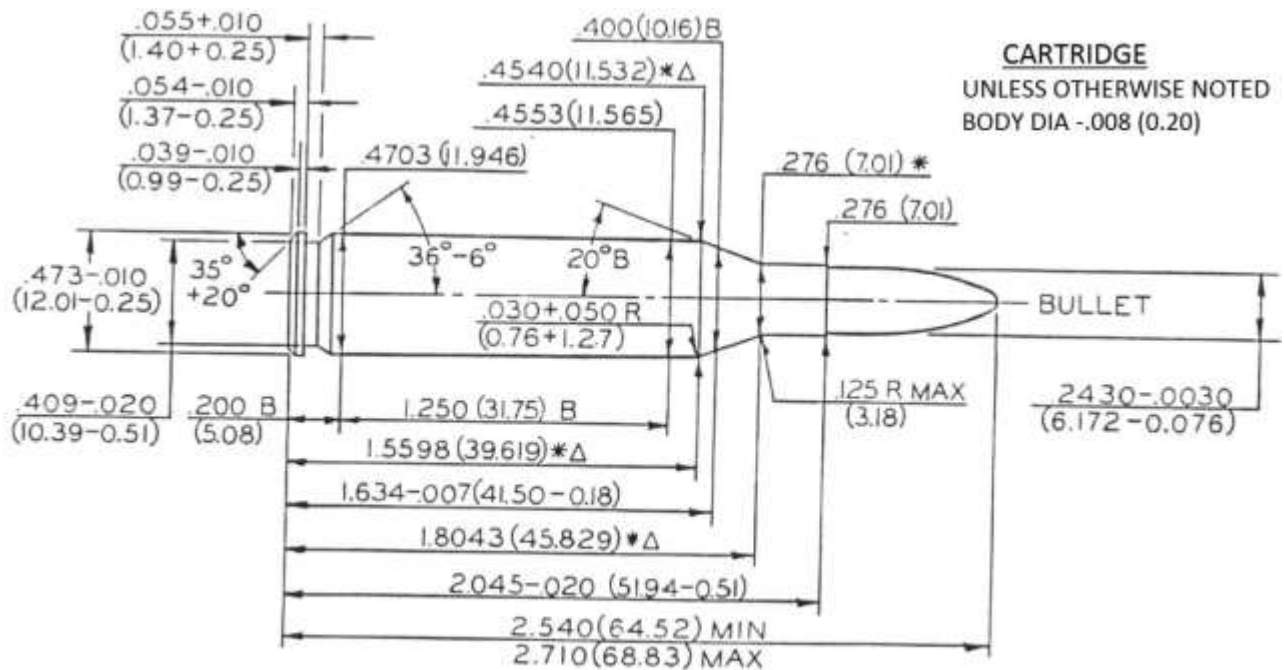

CARTRIDGE
 UNLESS OTHERWISE NOTED
 BODY DIA -.008 (0.20)



Δ 6 GROOVES
 Δ .068 + 0.002 (1.73 + 0.05) WIDE
 TWIST 10 (254) RH-
 OPTIONAL
 MIN BORE & GROOVE AREA
 .0453 SQ IN. (29.226 mm²)

CHAMBER
 UNLESS OTHERWISE NOTED
 ALL DIA +0.02 (0.05)
 LENGTH TOL +0.015 (0.38)

NOTE

B=BASIC
 (XX.XX)=MILLIMETERS
 ⊗ = HEADSPACE DIMENSION

* DIMENSIONS ARE TO INTERSECTION OF LINES. Δ=REFERENCE DIMENSION
 ALL CALCULATIONS APPLY AT MAXIMUM MATERIAL CONDITION (MMC)

NOTICE: This drawing is subject to change.
 Current version is available at www.saami.org.

MAXIMUM CARTRIDGE / MINIMUM CHAMBER
243 WINCHESTER SUPER SHORT MAGNUM

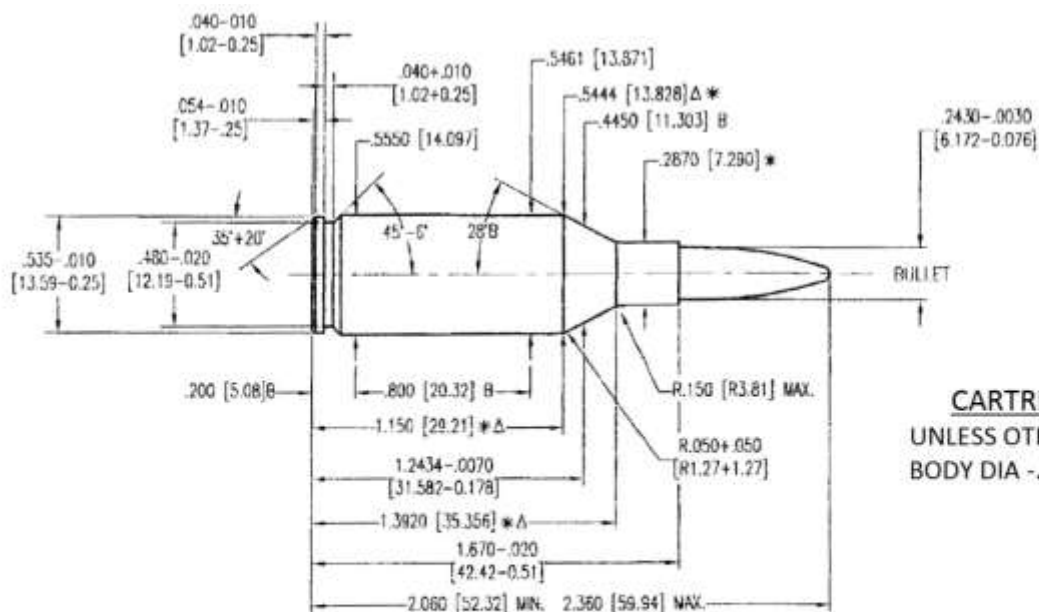

CARTRIDGE
 UNLESS OTHERWISE NOTED
 BODY DIA. -.008 (0.20)

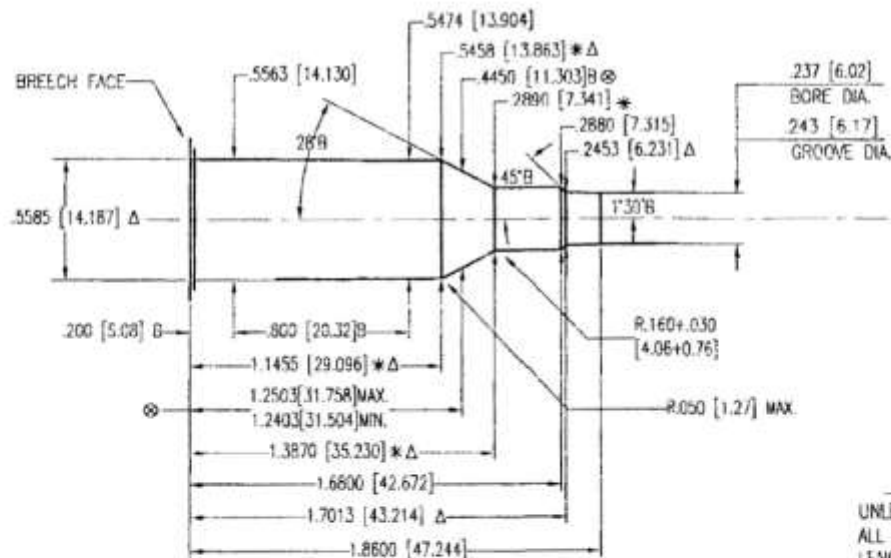

CHAMBER
 UNLESS OTHERWISE NOTED
 ALL DIA. +.002 [0.05]
 LENGTH TOL. +.015 [0.38]

NOTE:
 B = BASIC
 [XX.XX] = MILLIMETERS
 ⊕ = HEADSPACE DIMENSION
 Δ = REFERENCE DIMENSION
 * DIMENSIONS ARE TO INTERSECTION OF LINES
 ALL CALCULATIONS APPLY AT MAXIMUM MATERIAL CONDITION (MMC)

Δ 4 GROOVES
 Δ .100 +.002 [2.54 + 0.05] WIDE
 TWIST: 10 [254] R.H. OPTIONAL
 MIN. BORE & GROOVE
 AREA: .0453 SQ. IN. [29.225 mm²]

NOTICE: This drawing is subject to change.
 Current version is available at www.saami.org.

MAXIMUM CARTRIDGE / MINIMUM CHAMBER
25 WINCHESTER SUPER SHORT MAGNUM

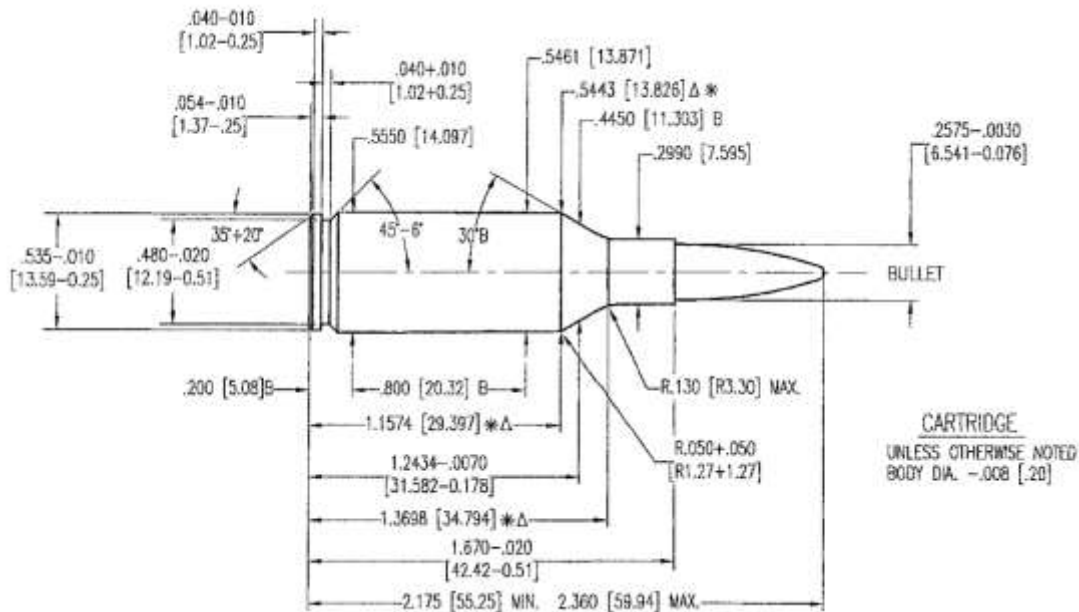

CARTRIDGE
 UNLESS OTHERWISE NOTED
 BODY DIA. -.008 [.20]

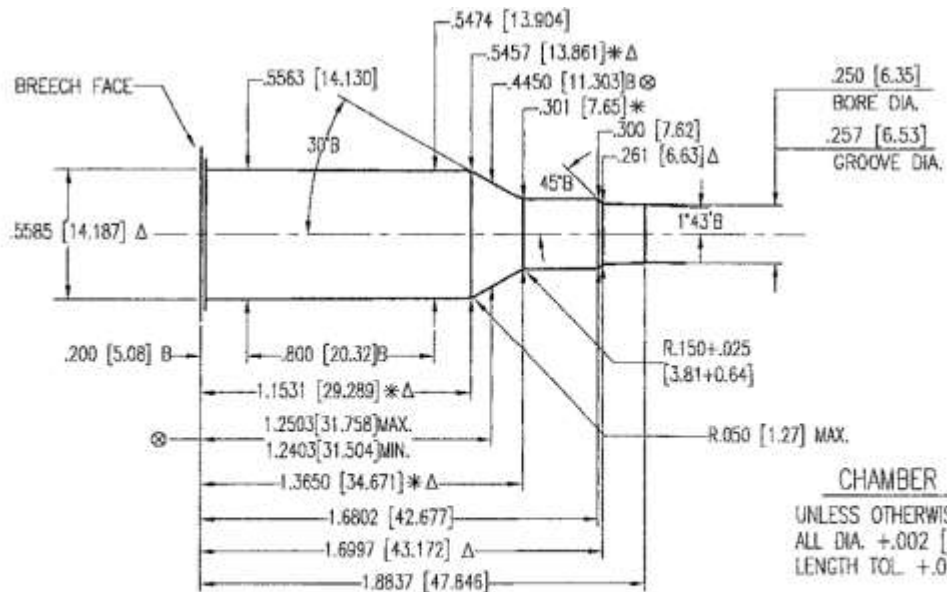

CHAMBER
 UNLESS OTHERWISE NOTED
 ALL DIA. +.002 [0.05]
 LENGTH TOL. +.015 [0.38]

Δ 6 GROOVES
 Δ .096+.002 [2.44+0.05] WIDE
 TWIST: 10[254] R.H. OPTIONAL
 MIN. BORE & GROOVE
 AREA: .0511 SQ. IN. [32.968 mm²]

NOTE:
 B=BASIC
 [XX.XX]=MILLIMETERS
 ⊗ = HEADSPACE DIMENSION
 Δ = REFERENCE DIMENSION
 * DIMENSIONS ARE TO INTERSECTION OF LINES
 ALL CALCULATIONS APPLY AT MAXIMUM MATERIAL CONDITION (MMC)

NOTICE: This drawing is subject to change.
 Current version is available at www.saami.org.

MAXIMUM CARTRIDGE / MINIMUM CHAMBER

25-06 REMINGTON

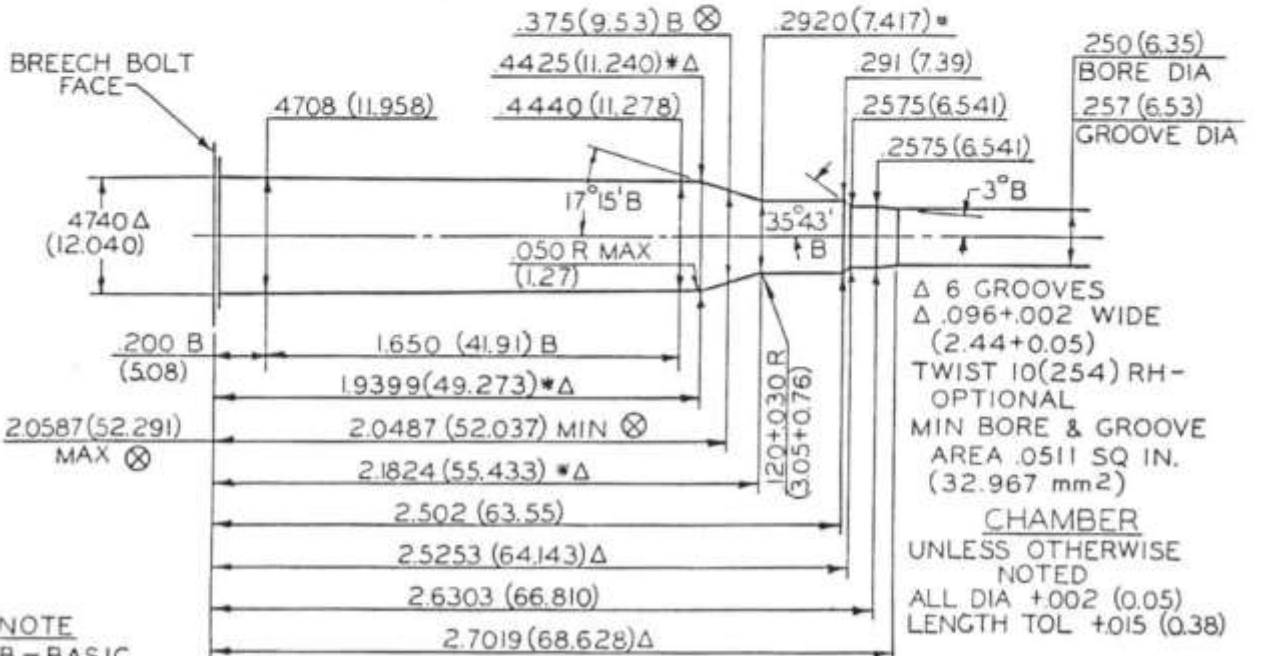
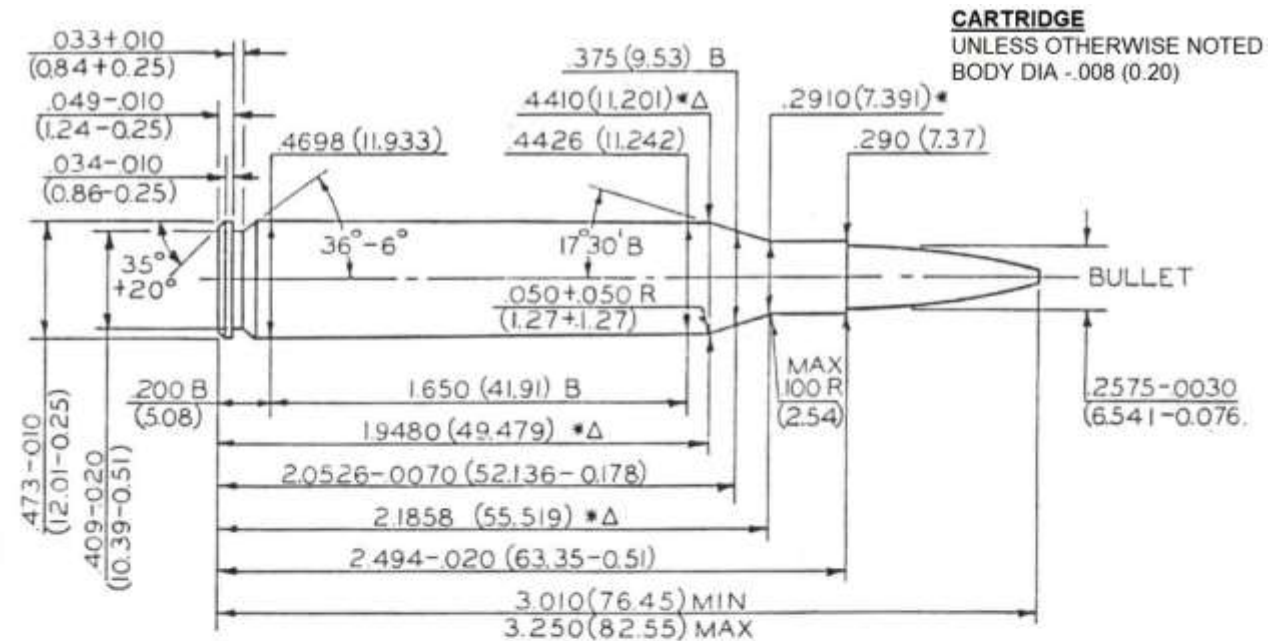

NOTE
 B = BASIC
 (XX.XX) = MILLIMETERS
 * DIMENSIONS ARE TO INTERSECTION OF LINES
 ALL CALCULATIONS APPLY AT MAXIMUM MATERIAL CONDITION (MMC)
 ⊗ = HEADSPACE DIMENSION
 Δ = REFERENCE DIMENSION

NOTICE: This drawing is subject to change.
 Current version is available at www.saami.org.

MAXIMUM CARTRIDGE / MINIMUM CHAMBER

25-20 WINCHESTER

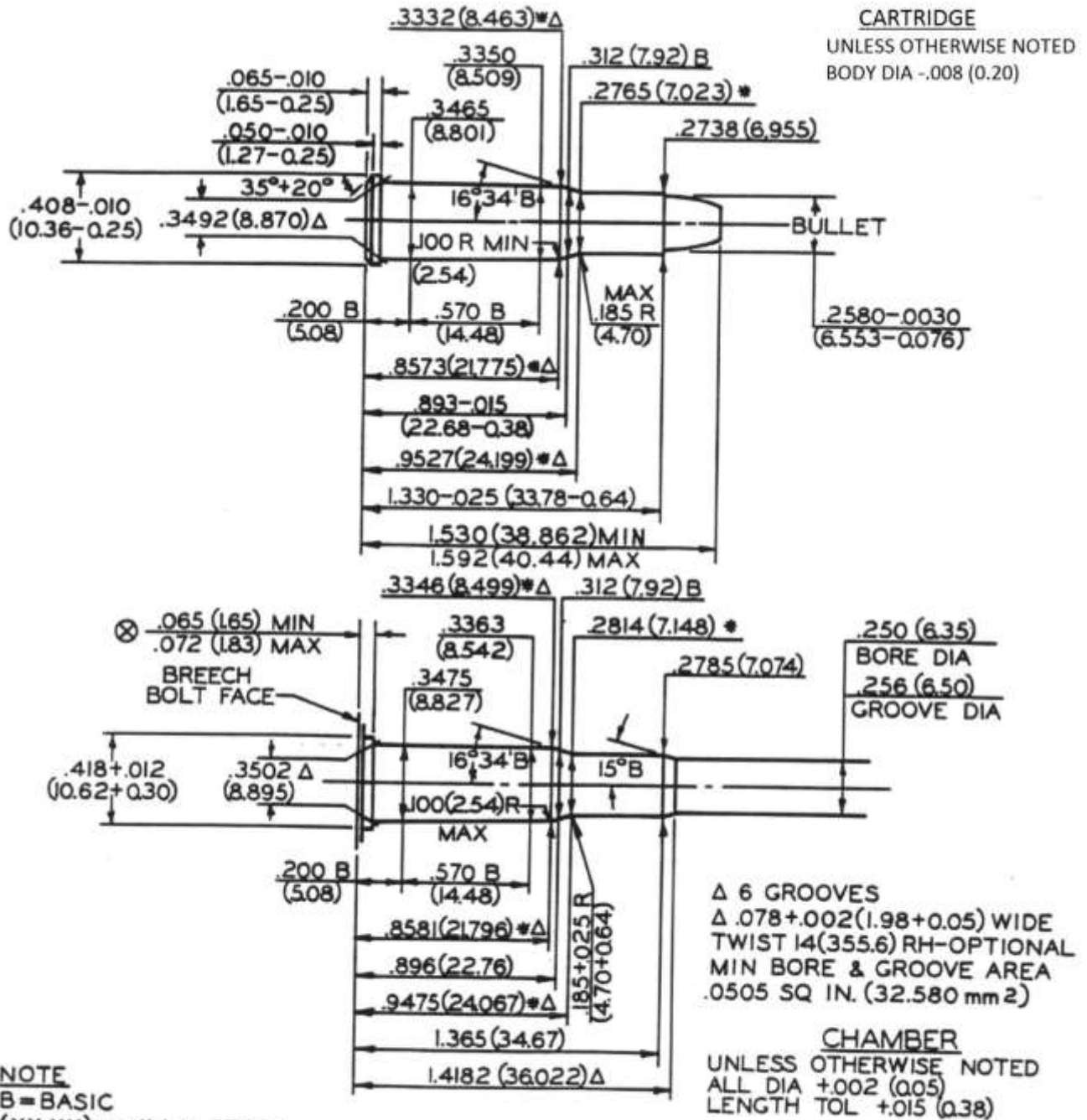

NOTICE: This drawing is subject to change.
 Current version is available at www.saami.org.

MAXIMUM CARTRIDGE / MINIMUM CHAMBER

25-35 WINCHESTER

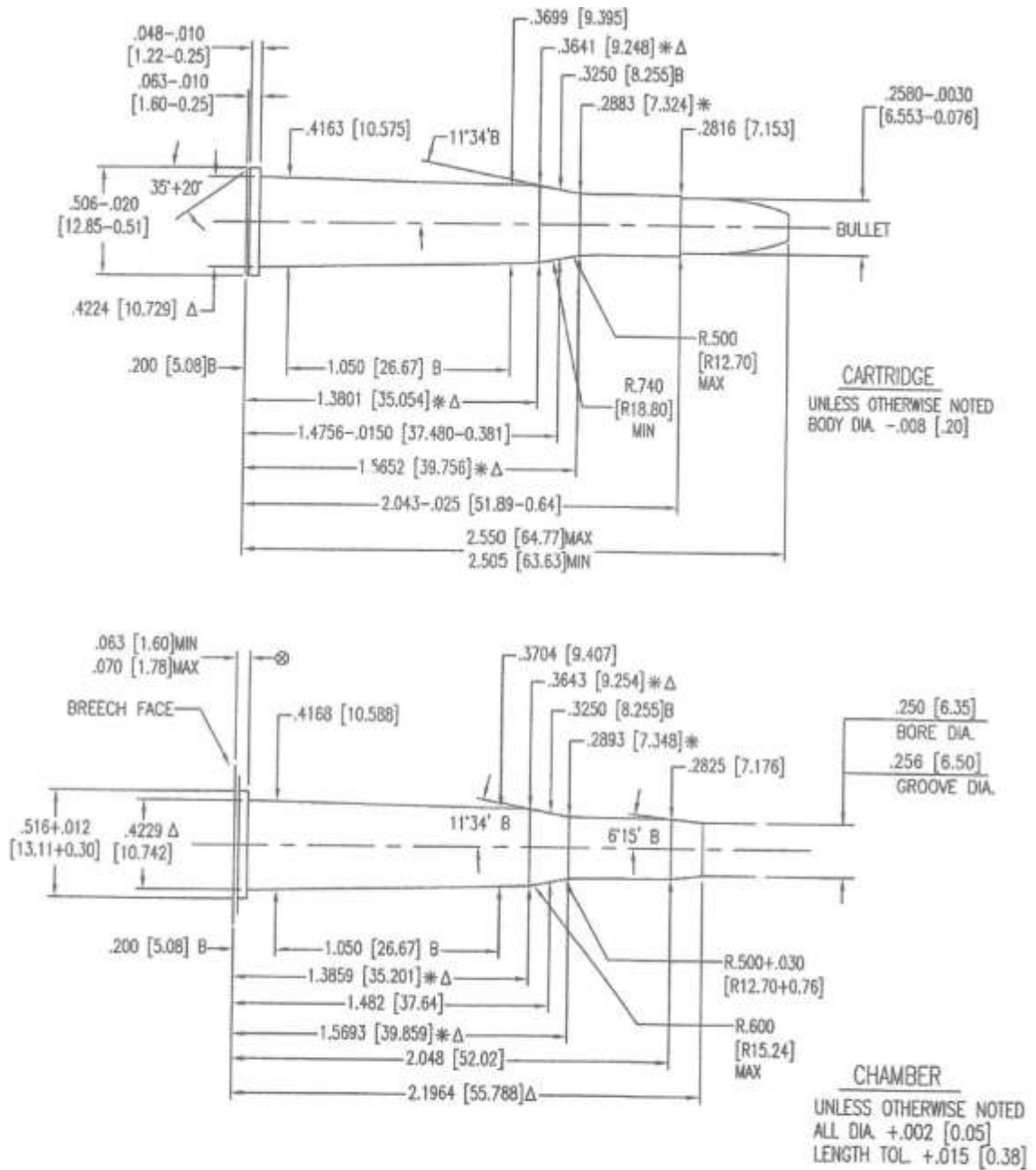

NOTE:
 B=BASIC
 [XX.XX]=MILLIMETERS
 ⊗ = HEADSPACE DIMENSION
 Δ = REFERENCE DIMENSION
 * DIMENSIONS ARE TO INTERSECTION OF LINES
 ALL CALCULATIONS APPLY AT MAXIMUM MATERIAL CONDITION (MMC)

Δ 6 GROOVES
 Δ .0786+0.0020 [1.996+0.051] WIDE
 TWIST: 8[203.2] R.H. OPTIONAL
 MIN. BORE & GROOVE
 AREA: .0505 SQ. IN. [32.580 mm²]

NOTICE: This drawing is subject to change.
 Current version is available at www.saami.org.

MAXIMUM CARTRIDGE / MINIMUM CHAMBER

250 SAVAGE

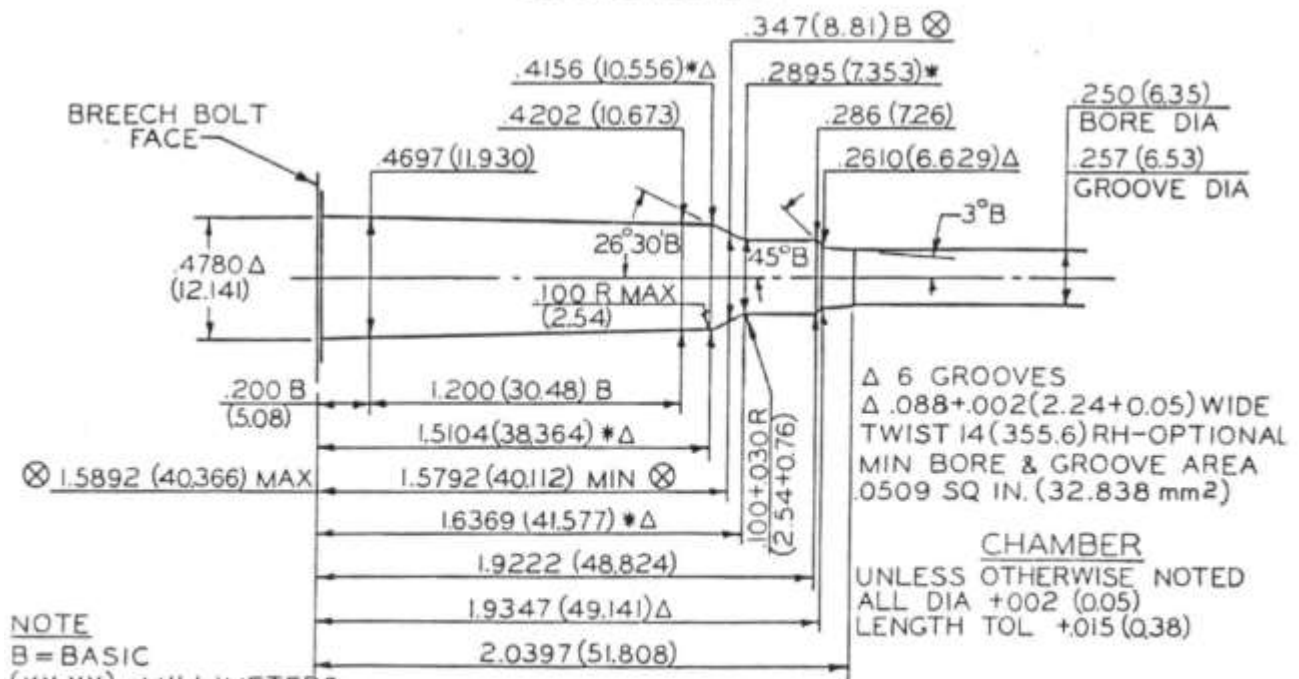
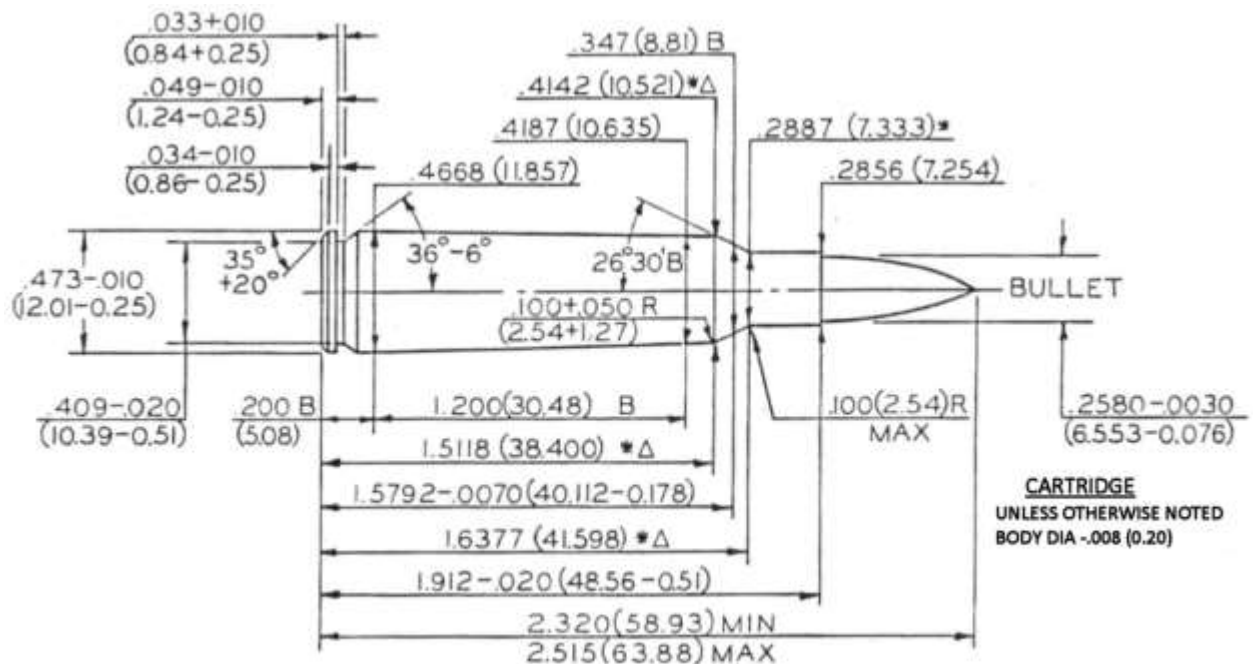

NOTE
 B = BASIC
 (XX.XX) = MILLIMETERS
 ⊗ = HEADSPACE DIMENSION
 Δ = REFERENCE DIMENSION
 * DIMENSIONS ARE TO INTERSECTION OF LINES
 ALL CALCULATIONS APPLY AT MAXIMUM MATERIAL CONDITION (MMC)

NOTICE: This drawing is subject to change.
 Current version is available at www.saami.org.

MAXIMUM CARTRIDGE / MINIMUM CHAMBER
257 ROBERTS / 257 ROBERTS +P

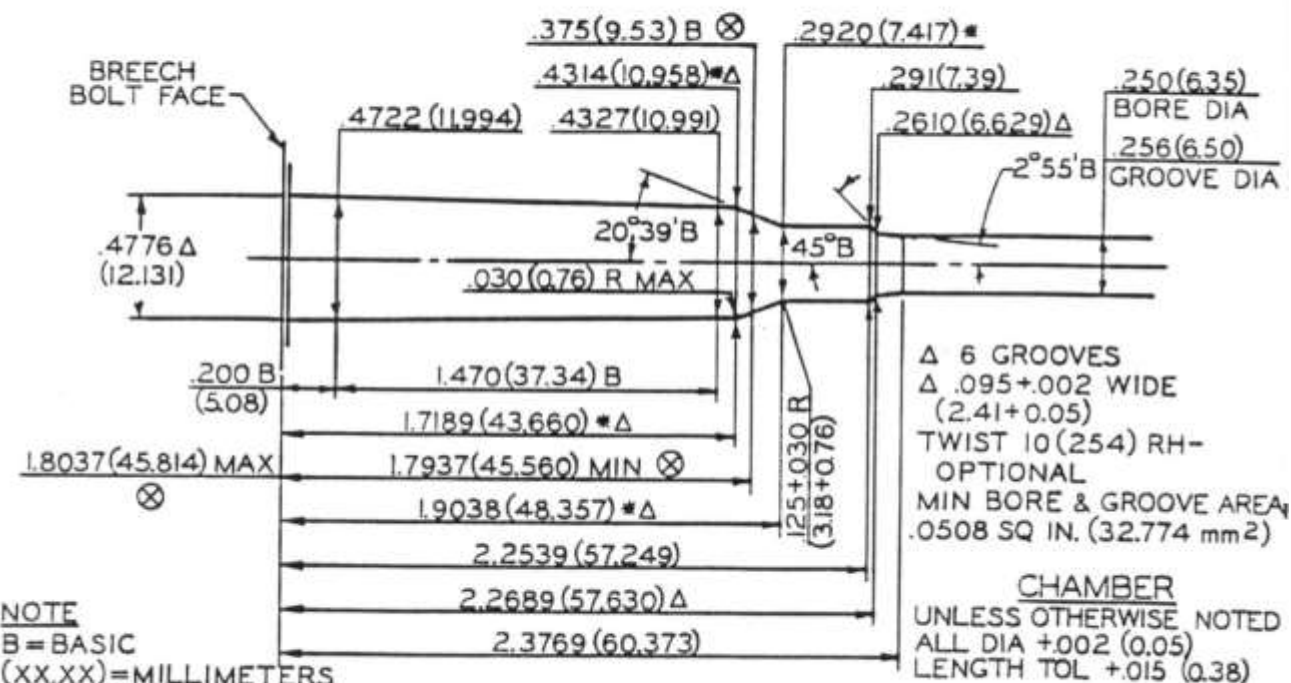
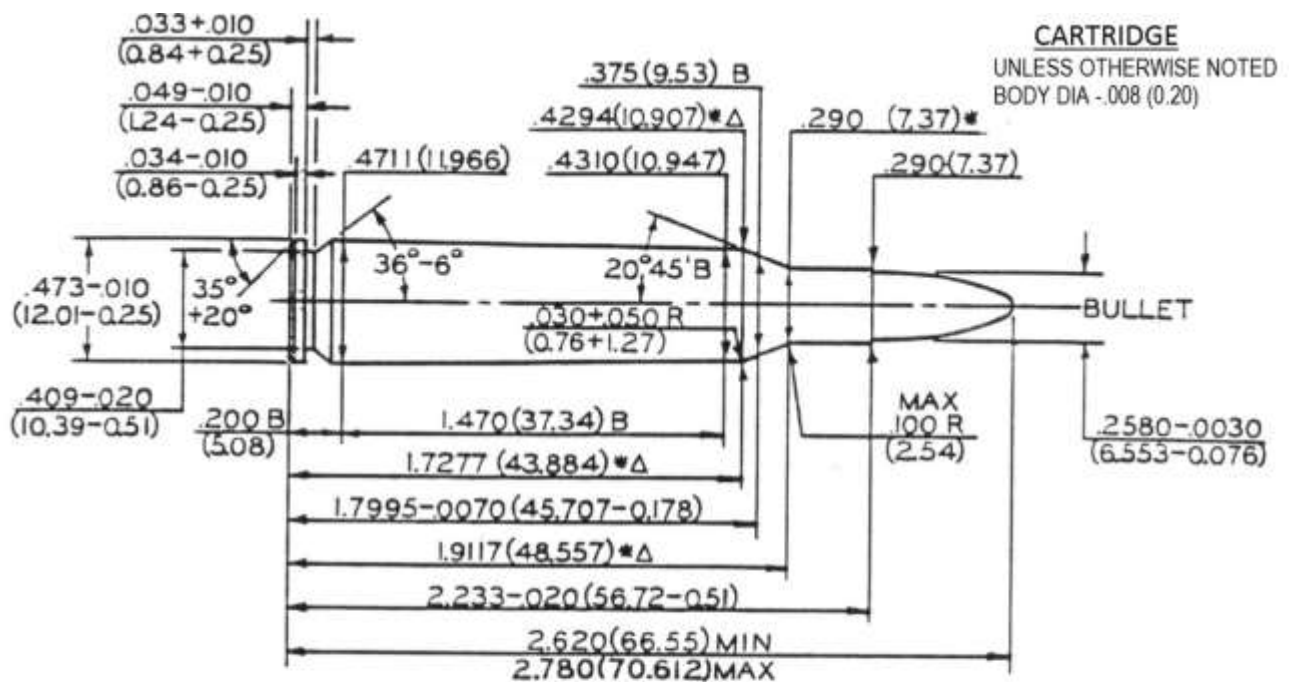

NOTE
 B = BASIC
 (XX.XX) = MILLIMETERS
 ⊗ = HEADSPACE DIMENSION
 Δ = REFERENCE DIMENSION
 * DIMENSIONS ARE TO INTERSECTION OF LINES
 ALL CALCULATIONS APPLY AT MAXIMUM MATERIAL CONDITION (MMC)

NOTICE: This drawing is subject to change.
 Current version is available at www.saami.org.

MAXIMUM CARTRIDGE / MINIMUM CHAMBER

257 WEATHERBY MAGNUM

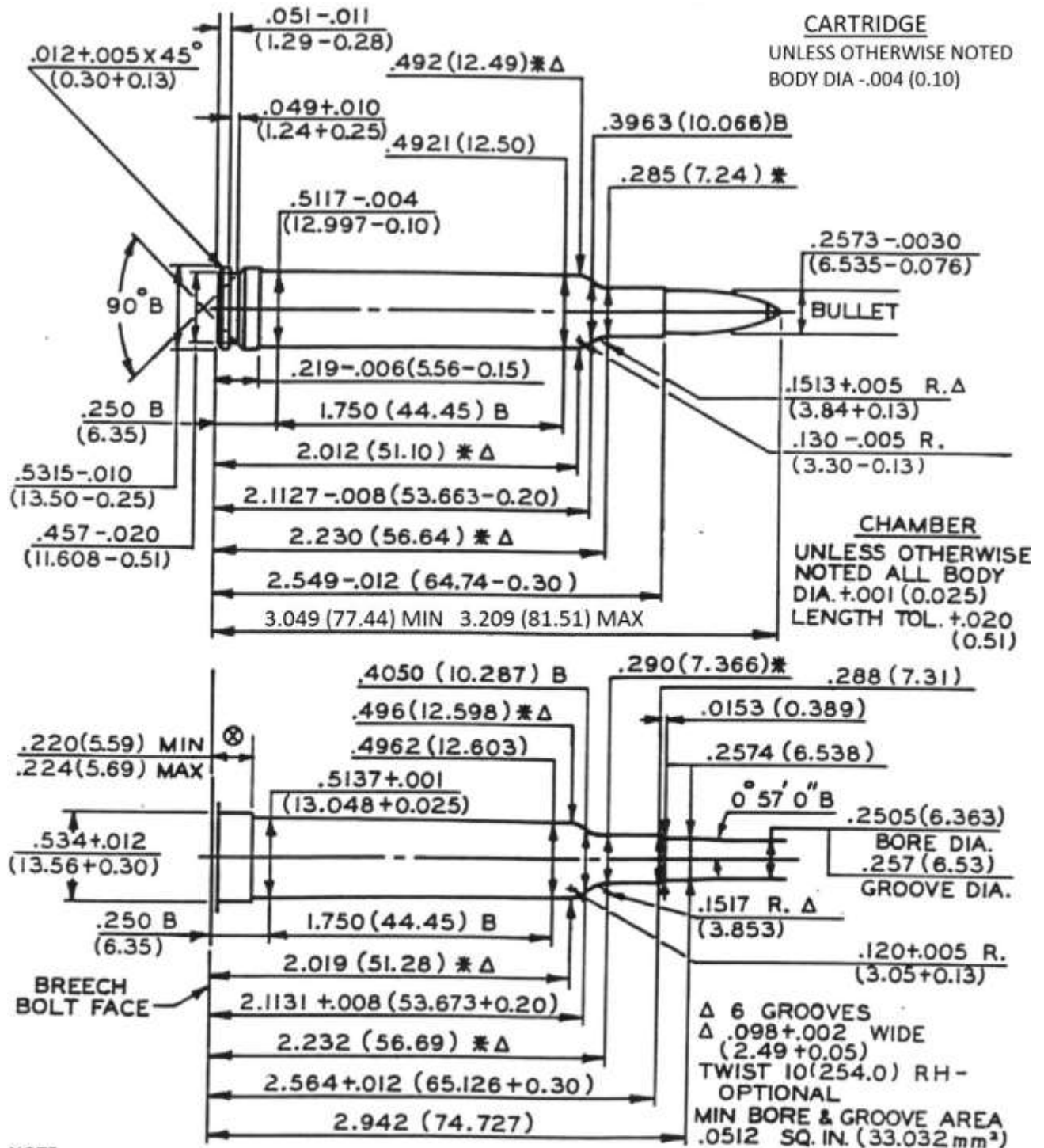

NOTICE: This drawing is subject to change.
 Current version is available at www.saami.org.

MAXIMUM CARTRIDGE / MINIMUM CHAMBER

26 NOSLER

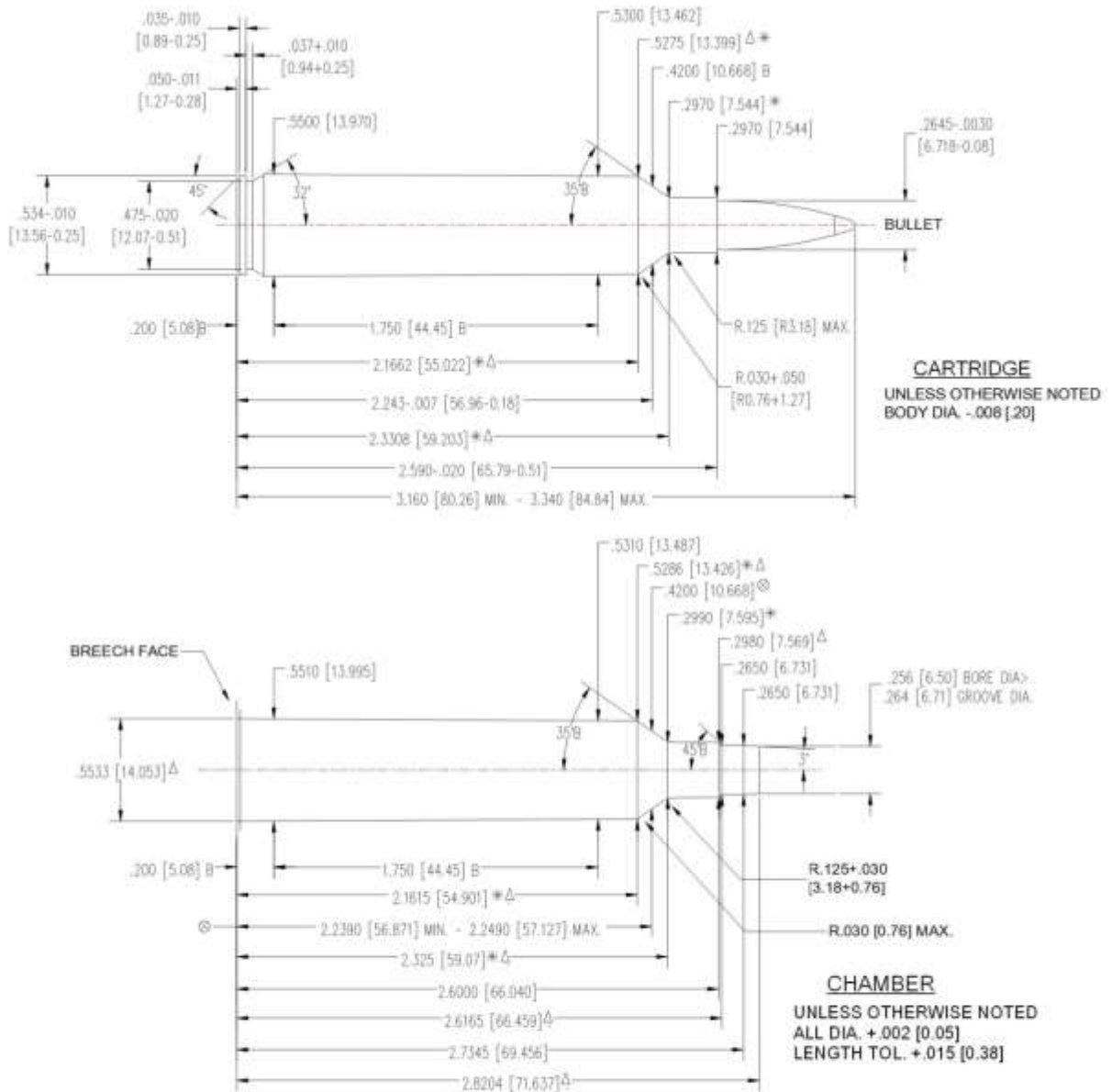

NOTE:
 B=BASIC
 [XX.XX]=MILLIMETERS
 ⊙ = HEADSPACE DIMENSION
 Δ = REFERENCE DIMENSION
 * DIMENSIONS ARE TO INTERSECTION OF LINES
 ALL CALCULATIONS APPLY AT MAXIMUM MATERIAL CONDITION (MMC)

Δ 6 GROOVES
 Δ $.095+0.02 [2.41+0.05]$ WIDE
 TWIST: 8[203] R.H. OPTIONAL
 MIN. BORE & GROOVE
 AREA: $.0538 \text{ SQ. IN. } [34.709 \text{ mm}^2]$

NOTICE: This drawing is subject to change.
 Current version is available at www.saami.org.

MAXIMUM CARTRIDGE / MINIMUM CHAMBER

260 REMINGTON

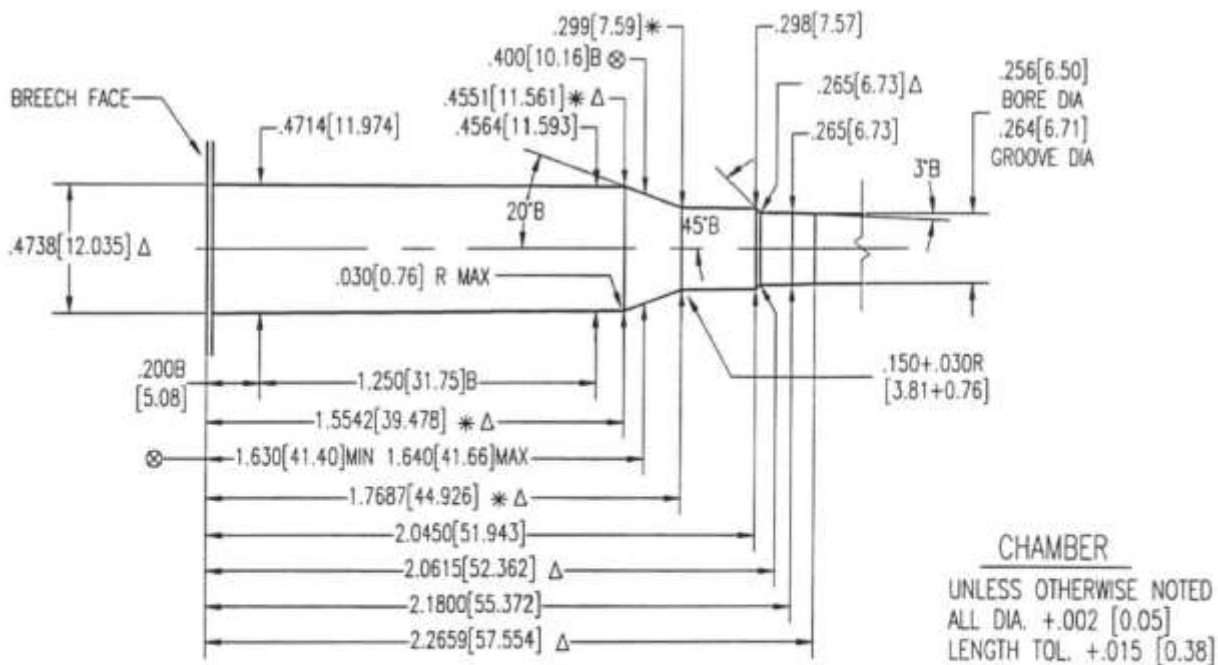
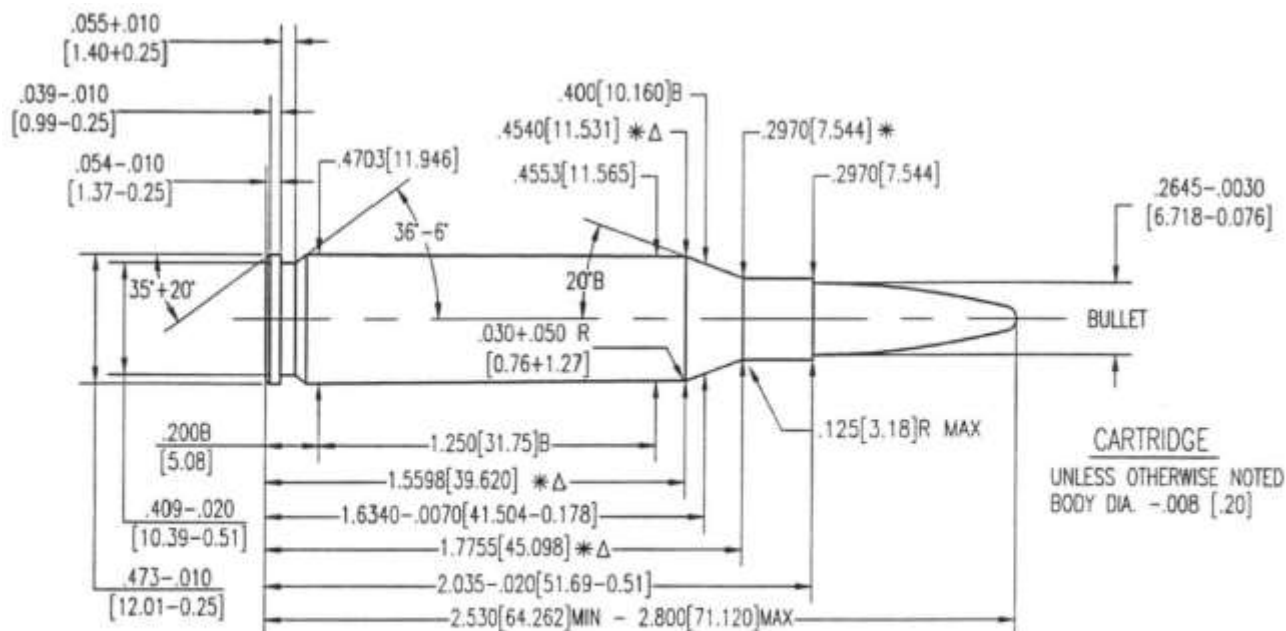

NOTE:
 B=BASIC
 [XX.XX]=MILLIMETERS
 ⊗ = HEADSPACE DIMENSION
 Δ = REFERENCE DIMENSION
 *DIMENSIONS ARE TO INTERSECTION OF LINES
 ALL CALCULATIONS APPLY AT MAXIMUM MATERIAL CONDITION (MMC)

Δ 6 GROOVES
 Δ .095+.002 [2.41+0.05] WIDE
 TWIST: 9[228] R.H. OPTIONAL
 MIN. BORE & GROOVE AREA: .0538 SQ. IN. [34.709 mm²]

NOTICE: This drawing is subject to change.
 Current version is available at www.saami.org.

MAXIMUM CARTRIDGE / MINIMUM CHAMBER

264 WINCHESTER MAGNUM

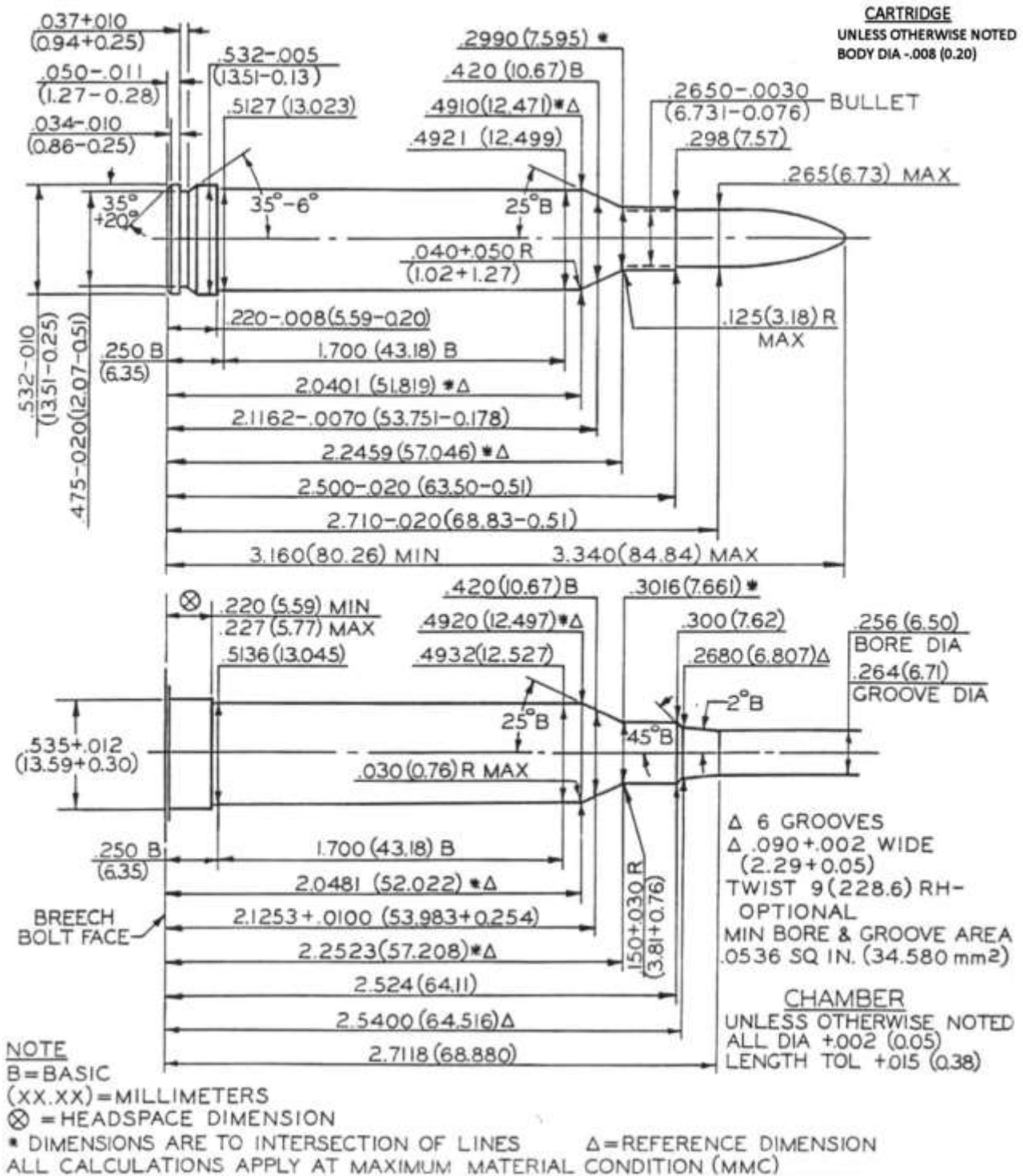

NOTICE: This drawing is subject to change.
 Current version is available at www.saami.org.

MAXIMUM CARTRIDGE / MINIMUM CHAMBER
27 NOSLER

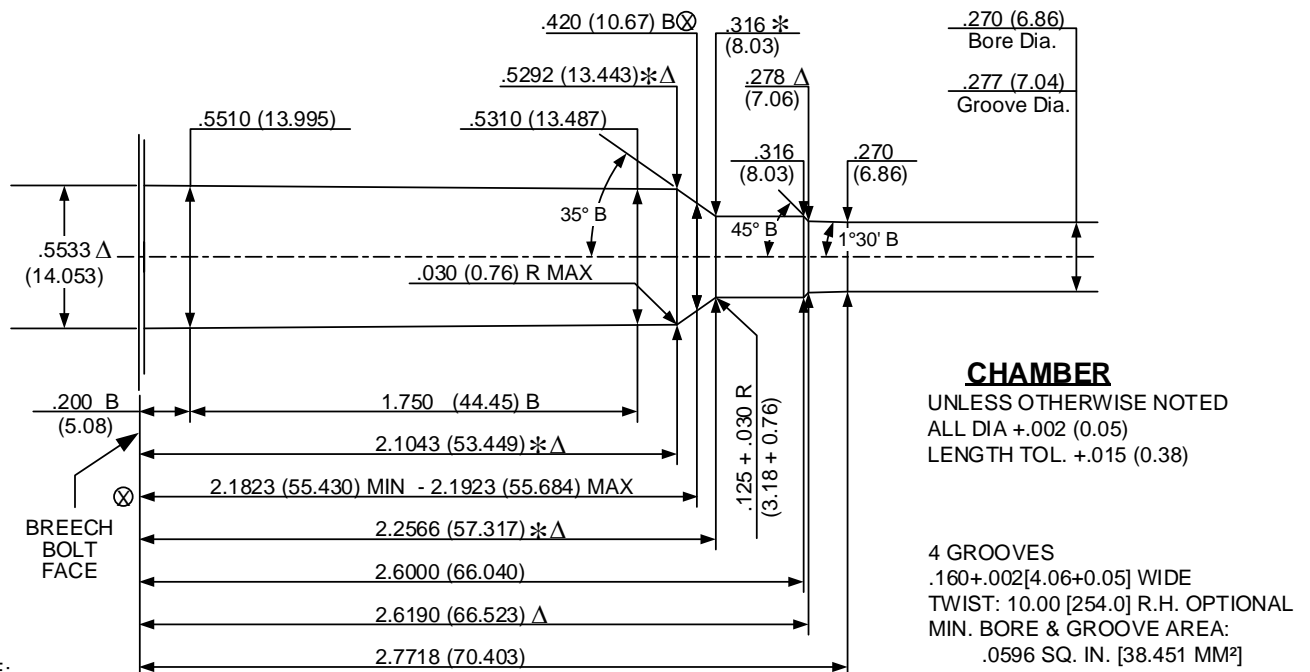
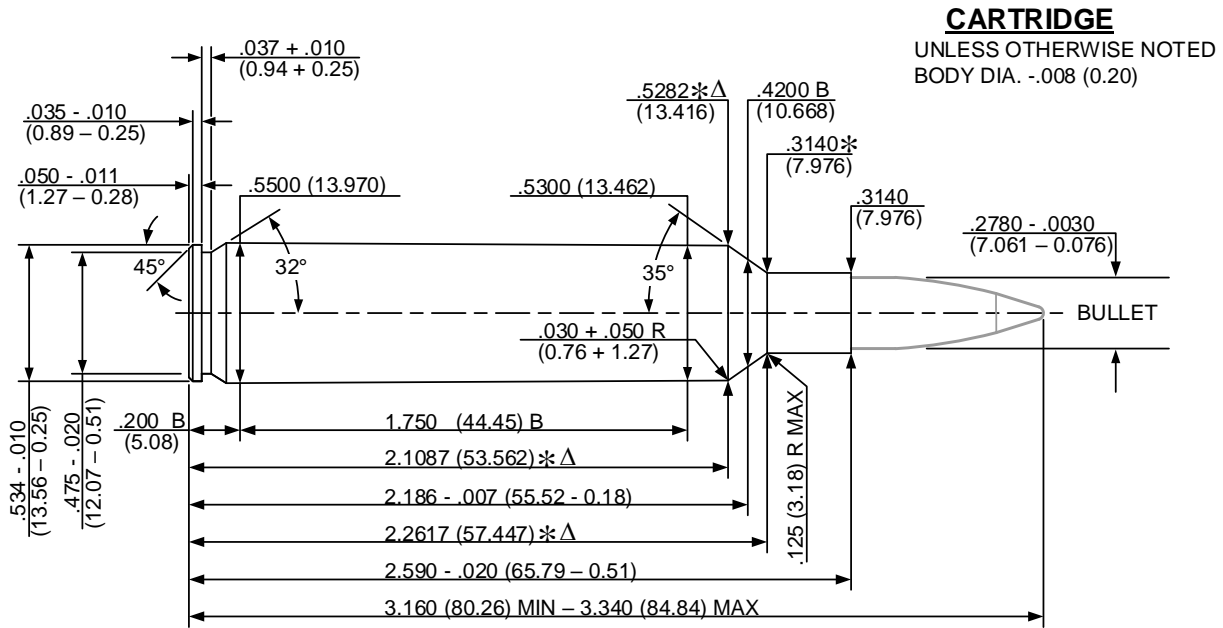

NOTE:
 B = BASIC
 (XX.XX) = MILLIMETERS
 ⊗ = HEAD SPACE DIMENSION
 Δ = REFERENCE DIMENSION
 * = DIMENSIONS ARE TO INTERSECTION OF LINES
 ALL CALCULATIONS APPLY AT MAXIMUM MATERIAL CONDITION (MMC)

NOTICE: This drawing is subject to change.
 Current version is available at www.saami.org.

MAXIMUM CARTRIDGE / MINIMUM CHAMBER
270 WINCHESTER SHORT MAGNUM

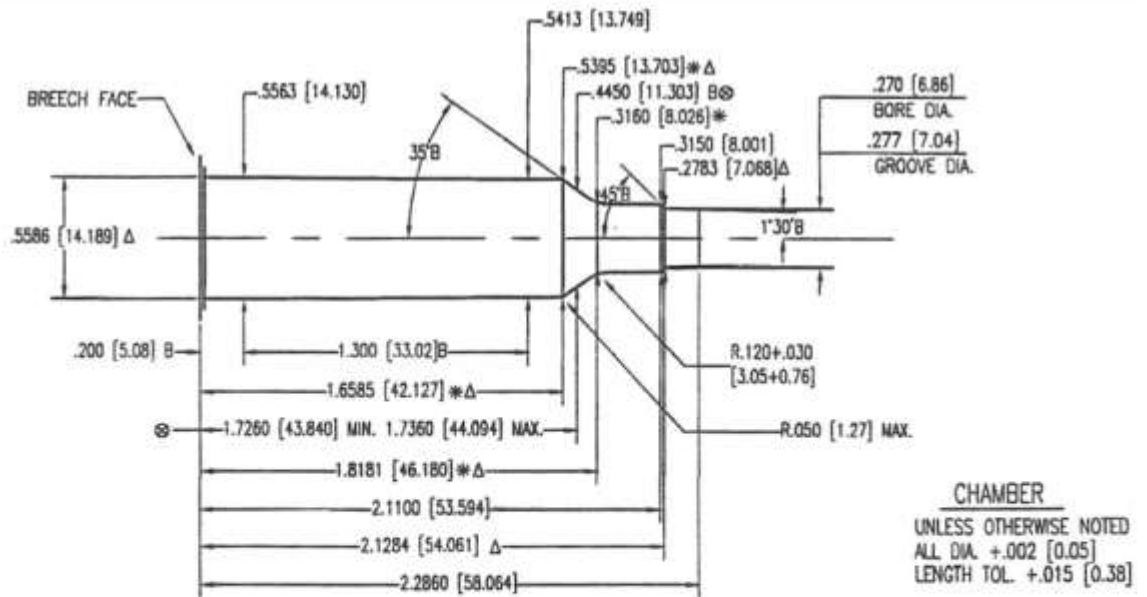
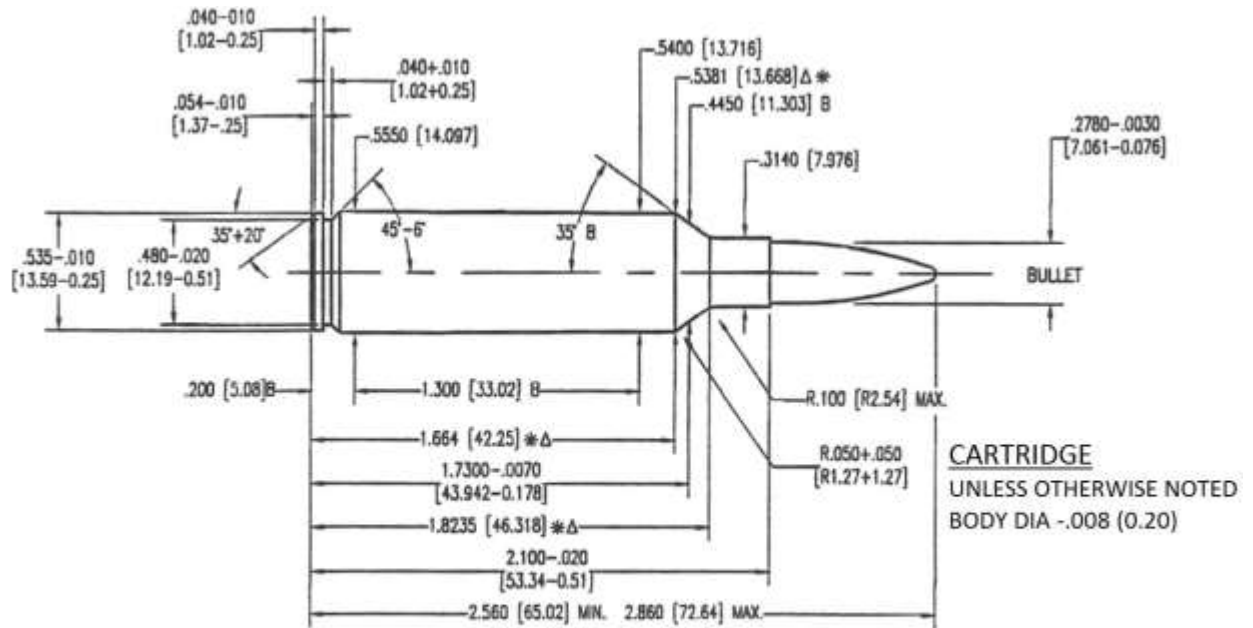

NOTE:
 B=BASIC
 [XX.XX]=MILLIMETERS
 ⊕ = HEADSPACE DIMENSION
 Δ = REFERENCE DIMENSION
 * DIMENSIONS ARE TO INTERSECTION OF LINES
 ALL CALCULATIONS APPLY AT MAXIMUM MATERIAL CONDITION (MMC)

Δ 4 GROOVES
 Δ.160+.002 [4.06+0.05] WIDE
 TWIST: 10[254] R.H. OPTIONAL
 MIN. BORE & GROOVE
 AREA: .0596 SQ. IN. [38.452 mm²]

NOTICE: This drawing is subject to change.
 Current version is available at www.saami.org.

MAXIMUM CARTRIDGE / MINIMUM CHAMBER

28 NOSLER

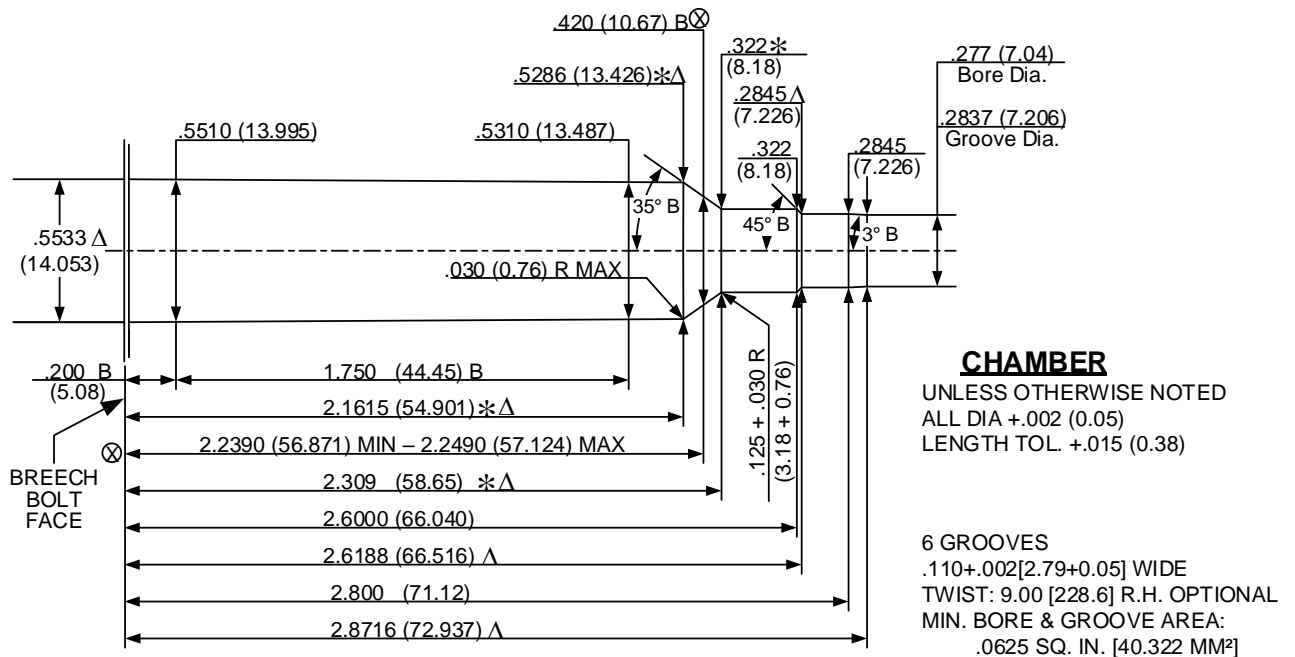
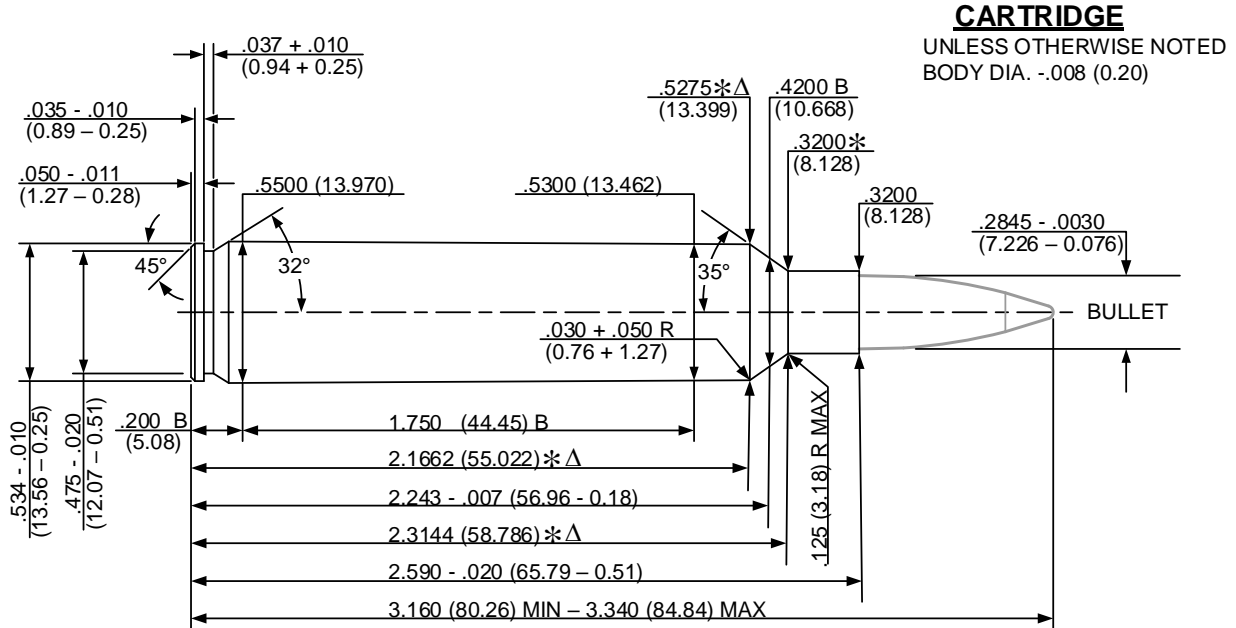

NOTE:
 B = BASIC
 (XX.XX) = MILLIMETERS
 ⊗ = HEAD SPACE DIMENSION
 Δ = REFERENCE DIMENSION
 * = DIMENSIONS ARE TO INTERSECTION OF LINES
 ALL CALCULATIONS APPLY AT MAXIMUM MATERIAL CONDITION (MMC)

NOTICE: This drawing is subject to change.
 Current version is available at www.saami.org.

MAXIMUM CARTRIDGE / MINIMUM CHAMBER

280 ACKLEY IMPROVED

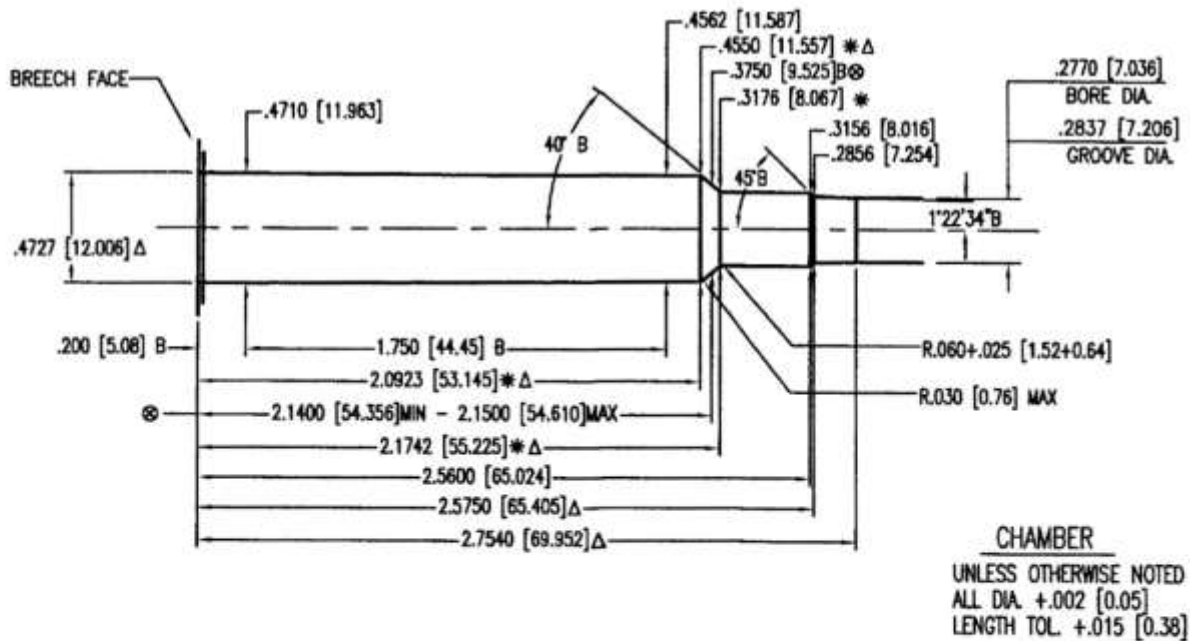
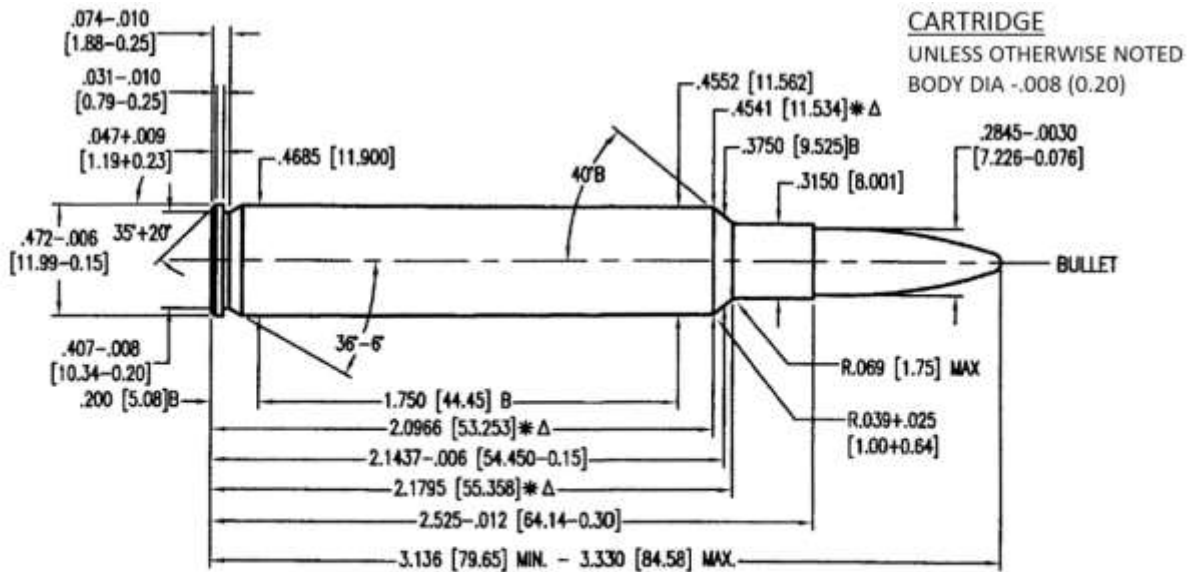

NOTE:
 B=BASIC
 [XX.XX]=MILLIMETERS
 ⊗ = HEADSPACE DIMENSION
 Δ = REFERENCE DIMENSION
 * DIMENSIONS ARE TO INTERSECTION OF LINES
 ALL CALCULATIONS APPLY AT MAXIMUM MATERIAL CONDITION (MMC)

MIN. BORE & GROOVE AREA:
 .0625 SQ. IN. [40.322 mm²]

OPTIONAL:
 Δ 4 GROOVES
 Δ .160+.002 [4.06+0.05] WIDE
 TWIST: 9 [228.6] R.H.

NOTICE: This drawing is subject to change.
 Current version is available at www.saami.org.

MAXIMUM CARTRIDGE / MINIMUM CHAMBER

280 REMINGTON
(7MM EXPRESS REMINGTON)

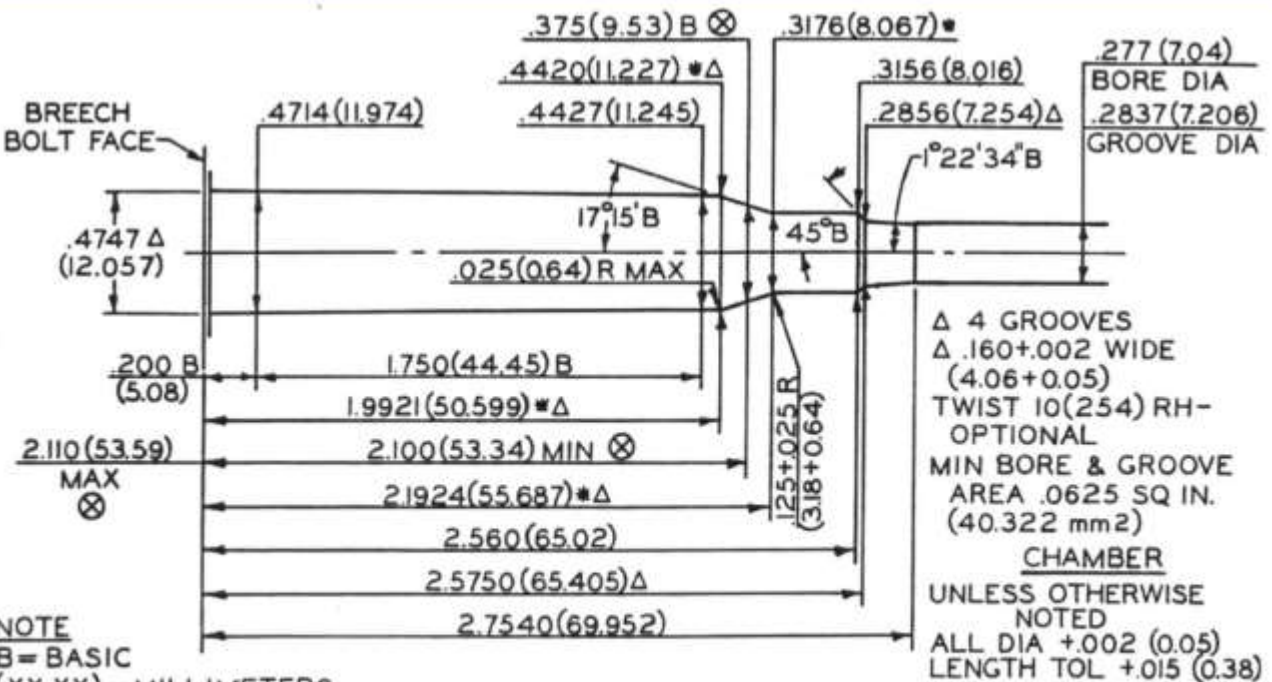
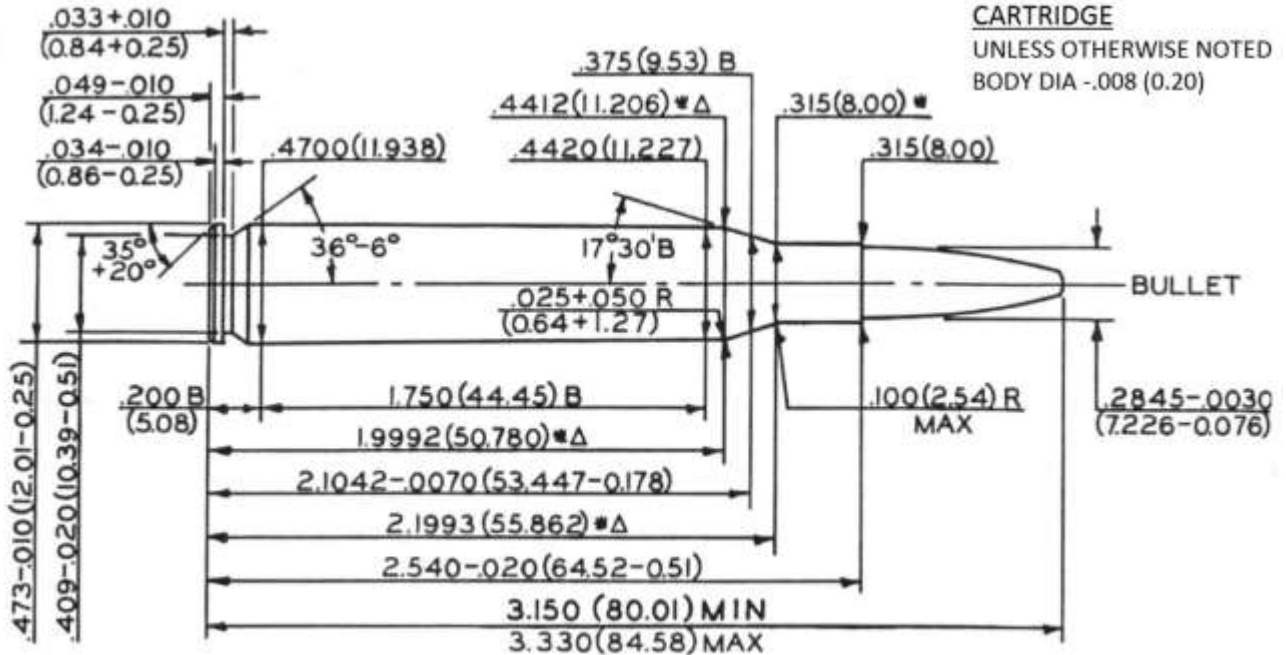

NOTE

B = BASIC
 (XX.XX) = MILLIMETERS

⊗ = HEADSPACE DIMENSION

* DIMENSIONS ARE TO INTERSECTION OF LINES Δ = REFERENCE DIMENSION
 ALL CALCULATIONS APPLY AT MAXIMUM MATERIAL CONDITION (MMC)

NOTICE: This drawing is subject to change.
 Current version is available at www.saami.org.

MAXIMUM CARTRIDGE / MINIMUM CHAMBER

284 WINCHESTER

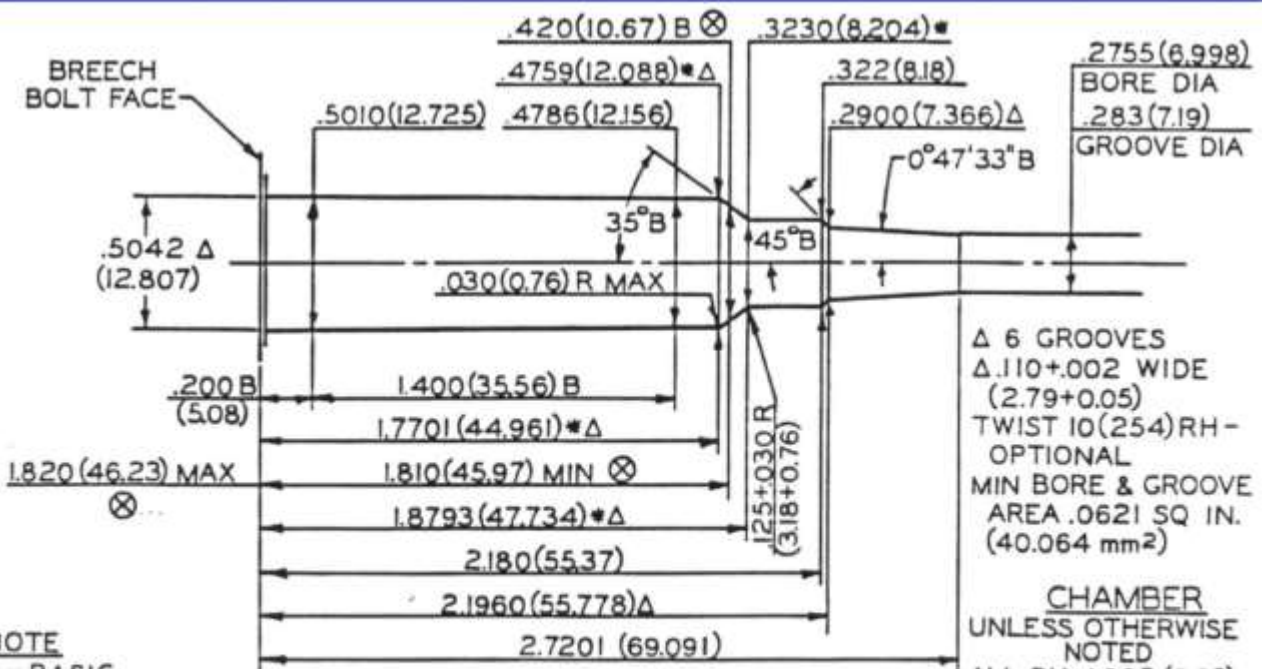
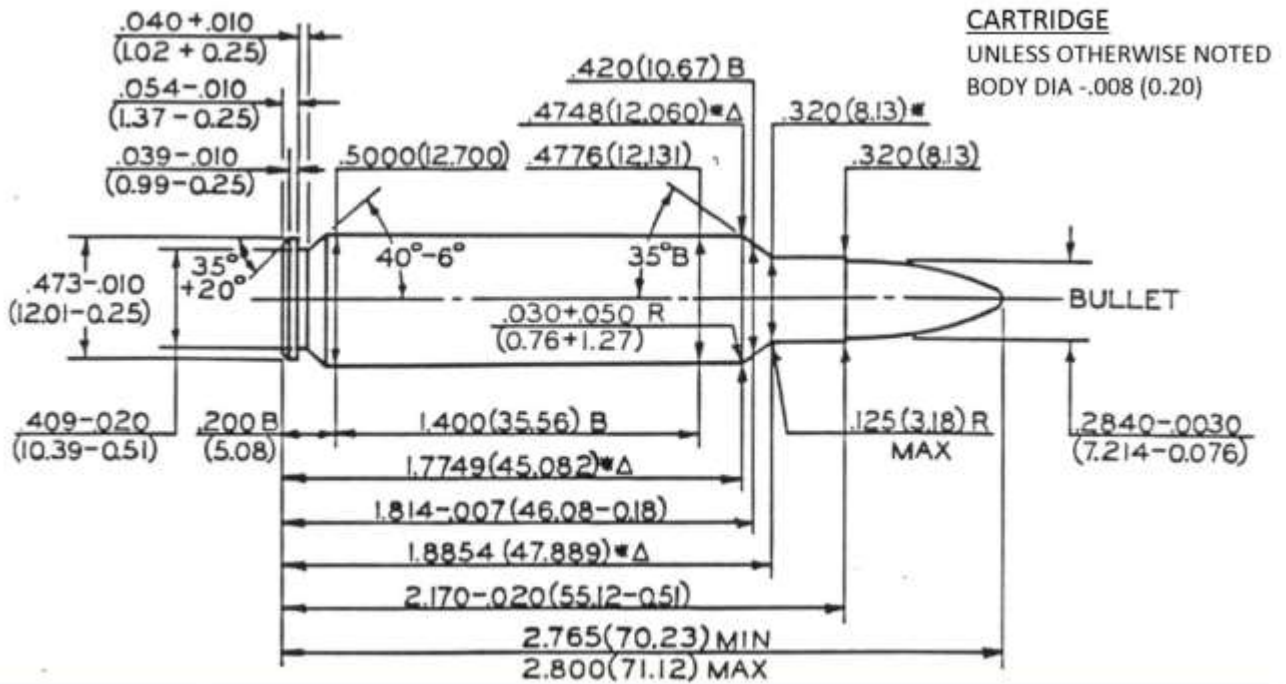

NOTE

B = BASIC

(XX.XX) = MILLIMETERS

⊗ = HEADSPACE DIMENSION

* DIMENSIONS ARE TO INTERSECTION OF LINES Δ = REFERENCE DIMENSION

ALL CALCULATIONS APPLY AT MAXIMUM MATERIAL CONDITION (MMC)

Δ 6 GROOVES
 Δ .110 + .002 WIDE
 (2.79 + 0.05)
 TWIST 10 (254) RH -
 OPTIONAL
 MIN BORE & GROOVE
 AREA .0621 SQ IN.
 (40.064 mm²)

CHAMBER
 UNLESS OTHERWISE
 NOTED
 ALL DIA +.002 (0.05)
 LENGTH TOL +.015
 (0.38)

NOTICE: This drawing is subject to change.
 Current version is available at www.saami.org.

MAXIMUM CARTRIDGE / MINIMUM CHAMBER

30 CARBINE

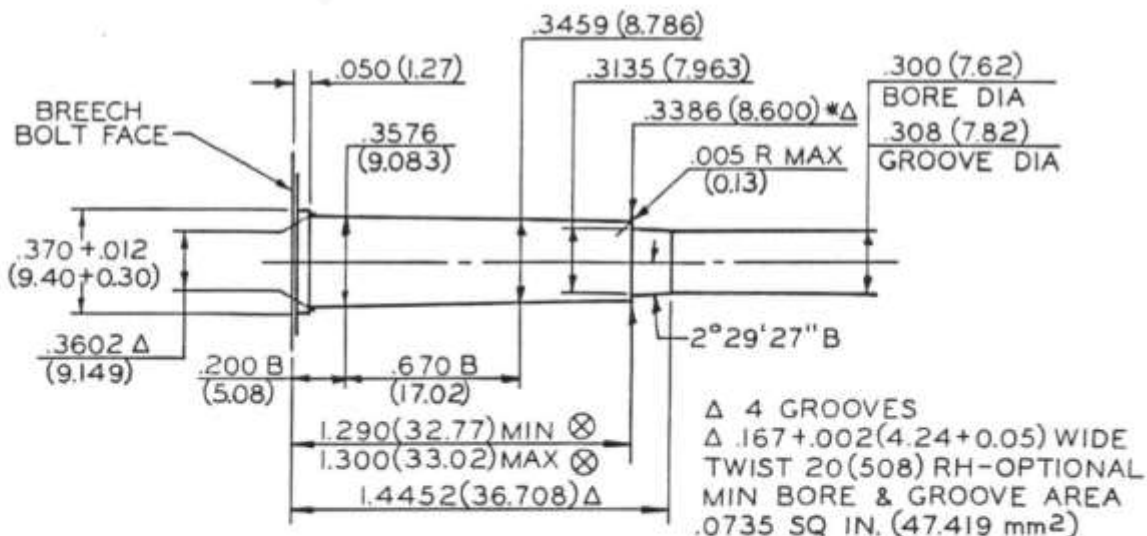
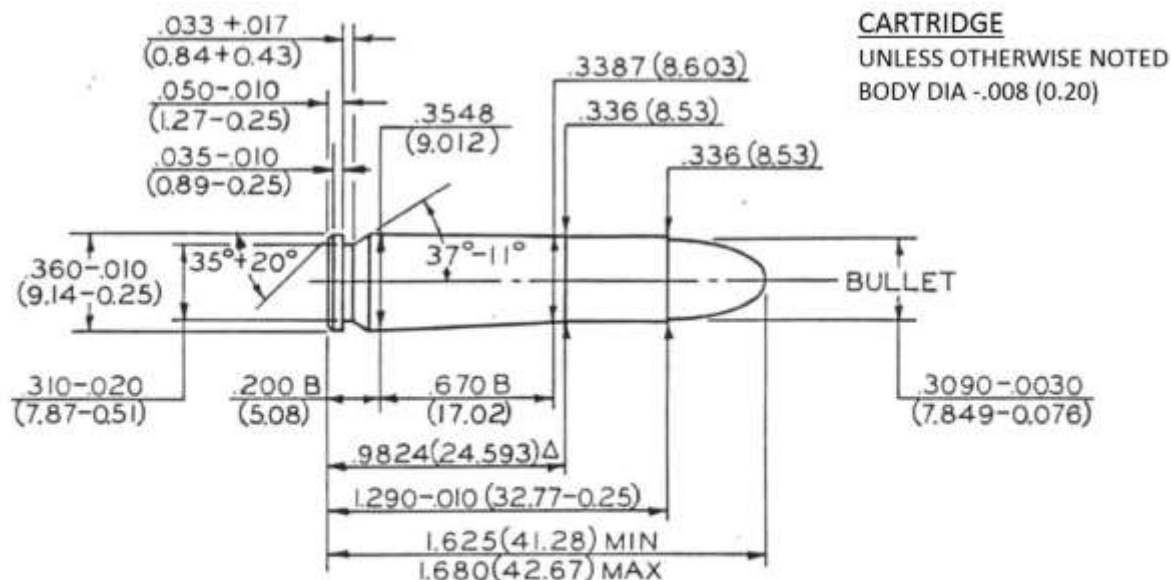

NOTE

B = BASIC

(XX.XX) = MILLIMETERS

⊗ = HEADSPACE DIMENSION

Δ = REFERENCE DIMENSION

* DIMENSIONS ARE TO INTERSECTION OF LINES

ALL CALCULATIONS APPLY AT MAXIMUM MATERIAL CONDITION (MMC)

NOTICE: This drawing is subject to change.
 Current version is available at www.saami.org.

MAXIMUM CARTRIDGE / MINIMUM CHAMBER

30 NOSLER

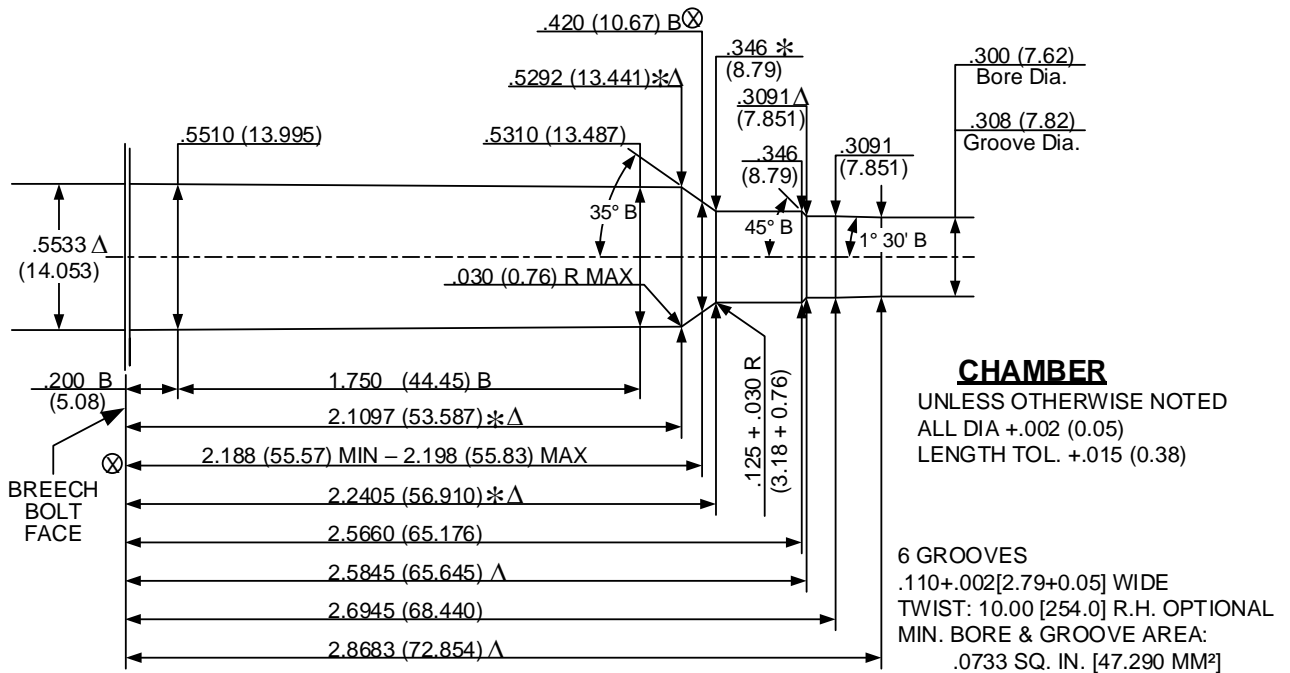
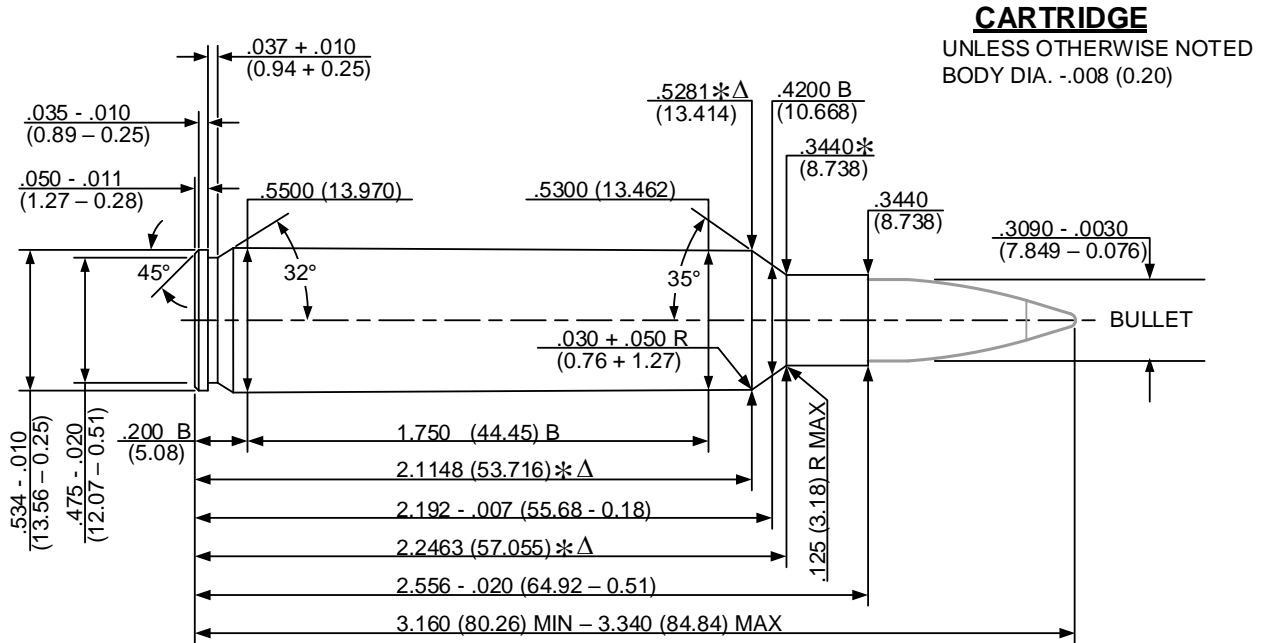

NOTE:
 B = BASIC
 (XX.XX) = MILLIMETERS
 ⊗ = HEAD SPACE DIMENSION
 Δ = REFERENCE DIMENSION
 * = DIMENSIONS ARE TO INTERSECTION OF LINES
 ALL CALCULATIONS APPLY AT MAXIMUM MATERIAL CONDITION (MMC)

NOTICE: This drawing is subject to change.
 Current version is available at www.saami.org.

MAXIMUM CARTRIDGE / MINIMUM CHAMBER

30 REMINGTON AR

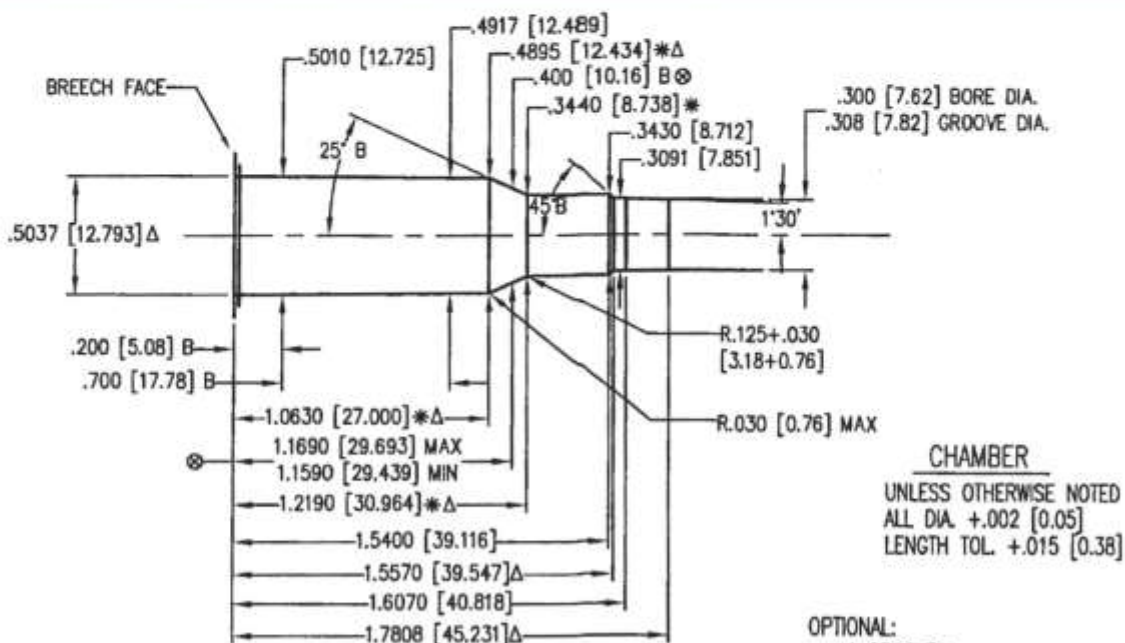
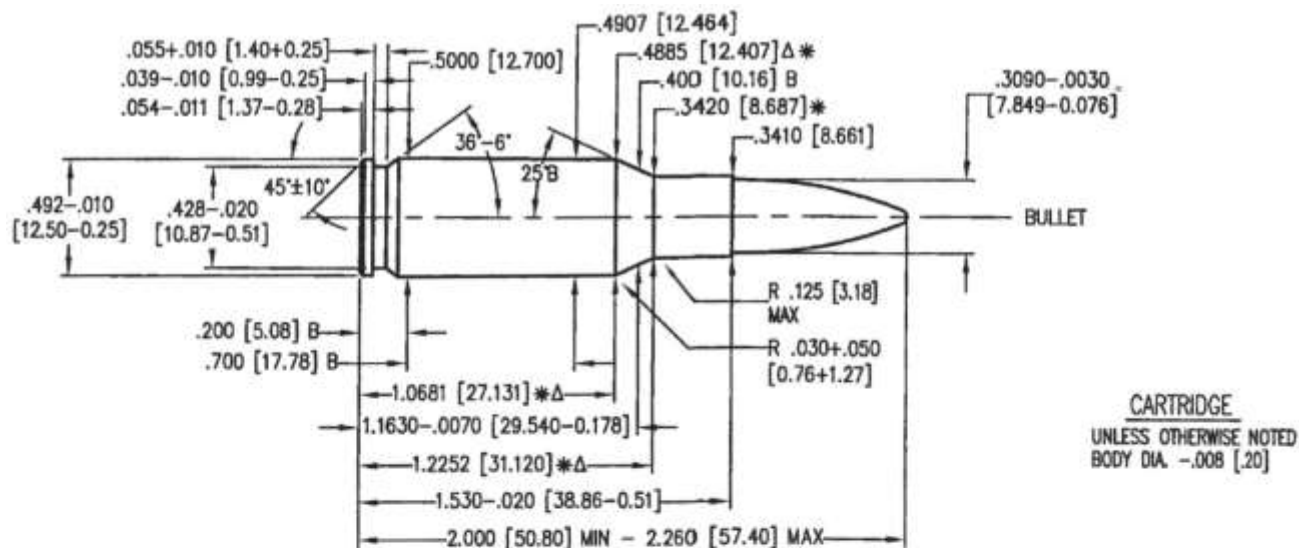

NOTE:
 B=BASIC
 [XX.XX]=MILLIMETERS
 ⊗ = HEADSPACE DIMENSION
 Δ = REFERENCE DIMENSION
 * DIMENSIONS ARE TO INTERSECTION OF LINES
 ALL CALCULATIONS APPLY AT MAXIMUM MATERIAL CONDITION (MMC)

OPTIONAL:
 Δ 4 GROOVES
 Δ .176+.002 [4.47+0.05] WIDE
 TWIST: 10 [254] R.H.
 MIN. BORE & GROOVE
 AREA: .0736 SQ. IN. [47.483 mm²]

NOTICE: This drawing is subject to change.
 Current version is available at www.saami.org.

MAXIMUM CARTRIDGE / MINIMUM CHAMBER

30 THOMPSON CENTER

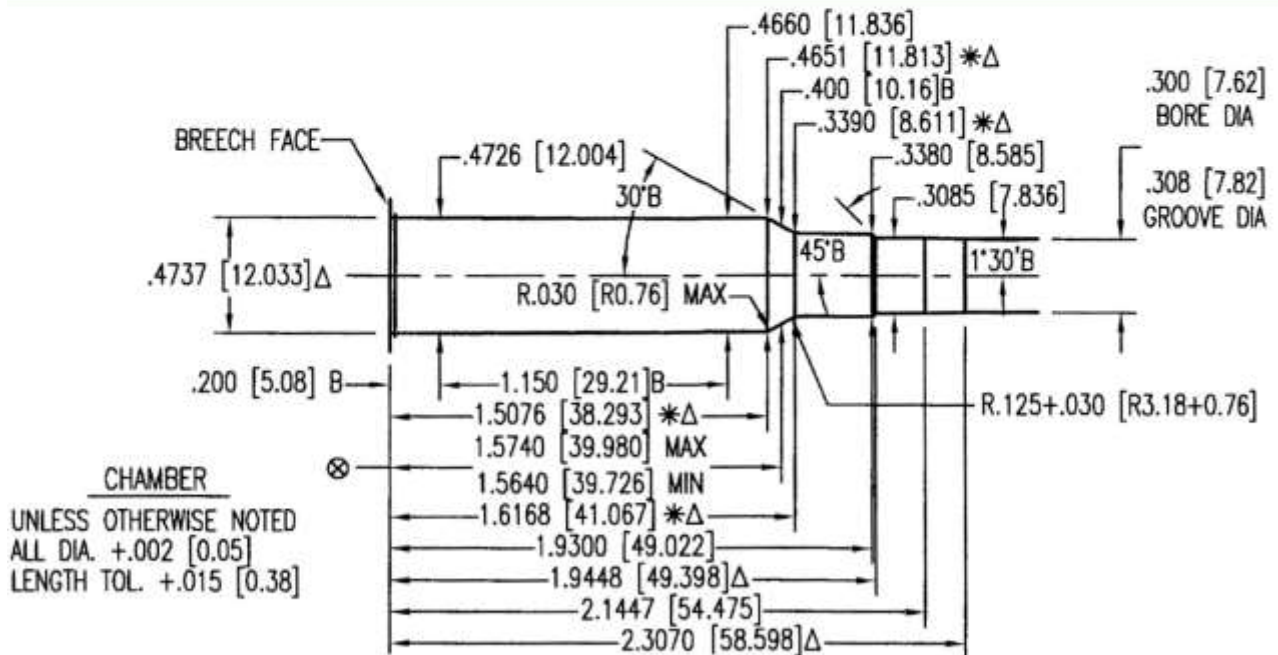
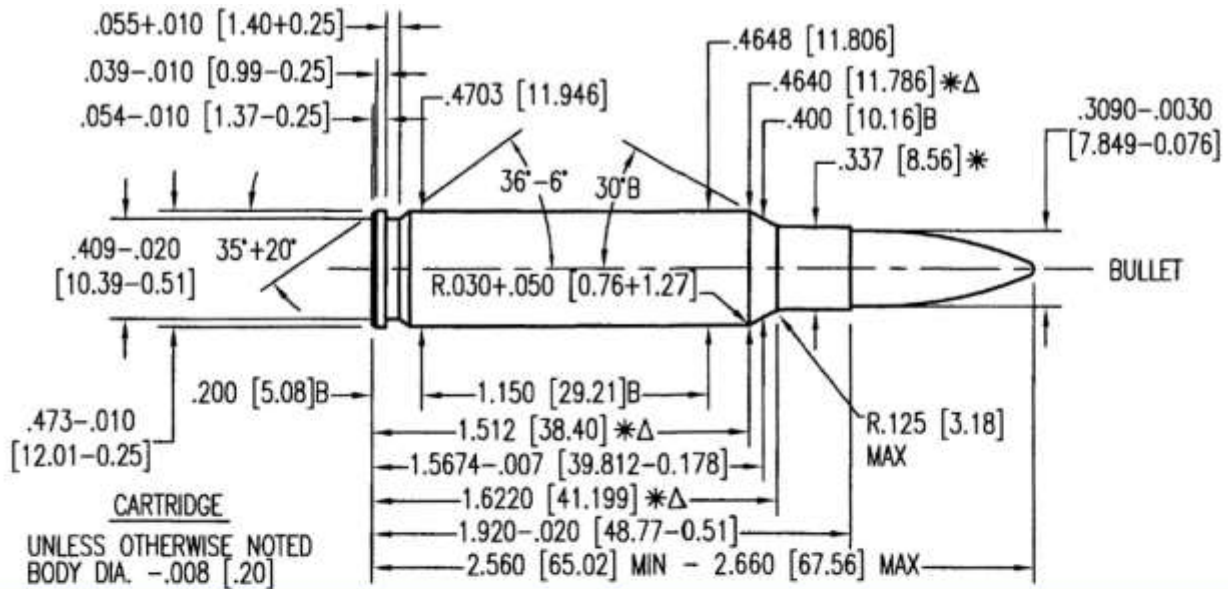

NOTE:

B=BASIC
 [XX.XX]=MILLIMETERS
 ⊗ = HEADSPACE DIMENSION
 Δ = REFERENCE DIMENSION
 * DIMENSIONS ARE TO INTERSECTION OF LINES
 ALL CALCULATIONS APPLY AT MAXIMUM MATERIAL CONDITION (MMC)

OPTIONAL:

Δ 4 GROOVES
 Δ.176+.002 [4.47+0.05] WIDE
 TWIST: 12 [304.8] R.H.
 MIN. BORE & GROOVE AREA:
 .0736 SQ. IN. [47.483 mm²]

NOTICE: This drawing is subject to change.
 Current version is available at www.saami.org.

MAXIMUM CARTRIDGE / MINIMUM CHAMBER

30-06 SPRINGFIELD

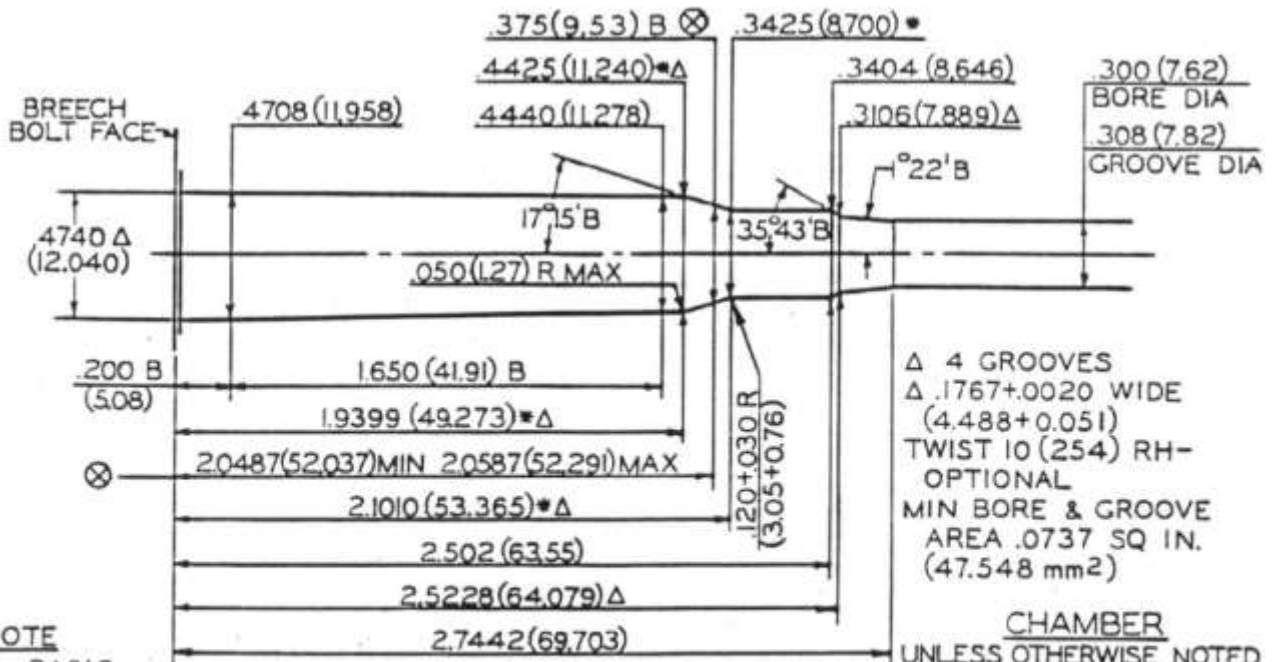
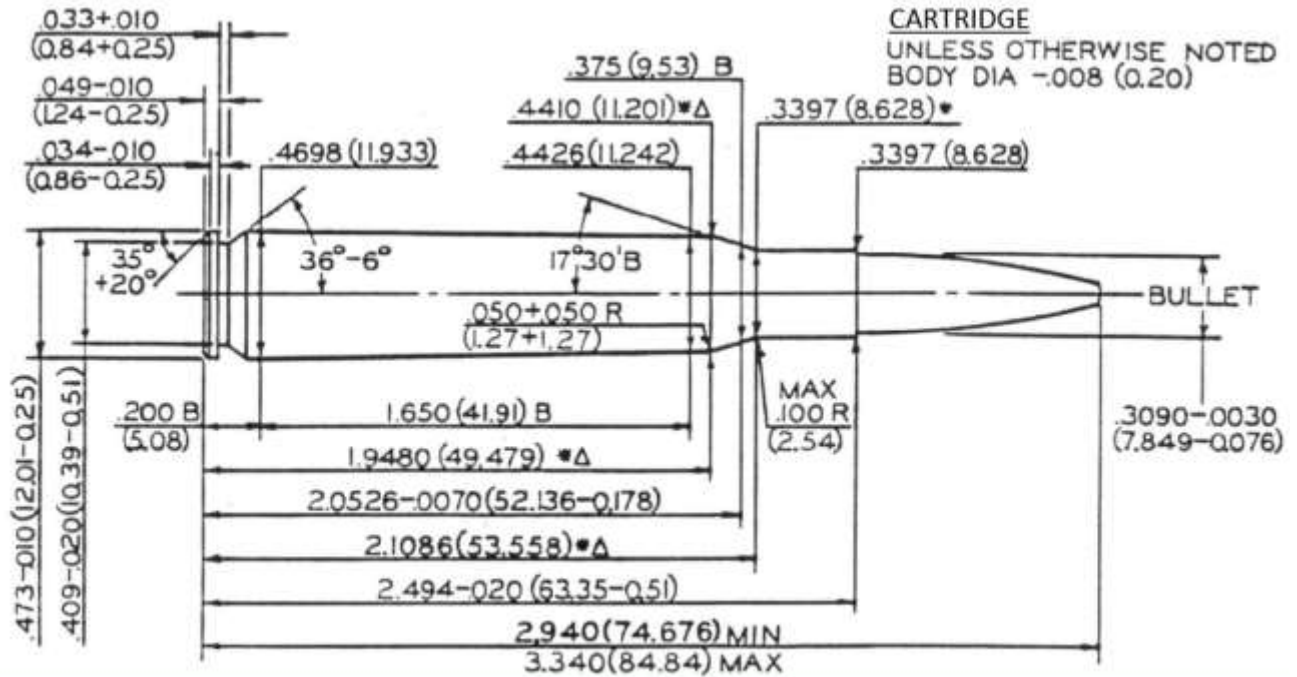

NOTE

B = BASIC

(XX.XX) = MILLIMETERS

⊗ = HEADSPACE DIMENSION

* DIMENSIONS ARE TO INTERSECTION OF LINES

Δ = REFERENCE DIMENSION

ALL CALCULATIONS APPLY AT MAXIMUM MATERIAL CONDITION (MMC)

CHAMBER

UNLESS OTHERWISE NOTED
 ALL DIA $+.002 (0.05)$
 LENGTH TOL $+.015 (0.38)$

NOTICE: This drawing is subject to change.
 Current version is available at www.saami.org.

MAXIMUM CARTRIDGE / MINIMUM CHAMBER

30-30 WINCHESTER

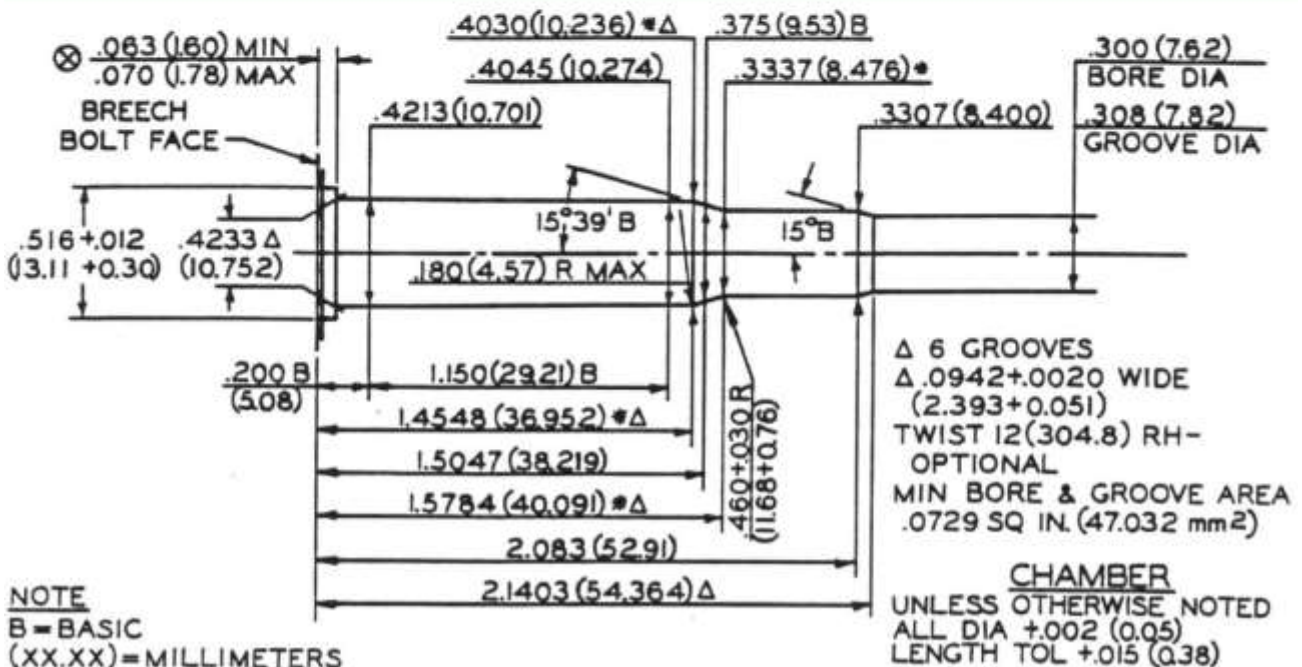
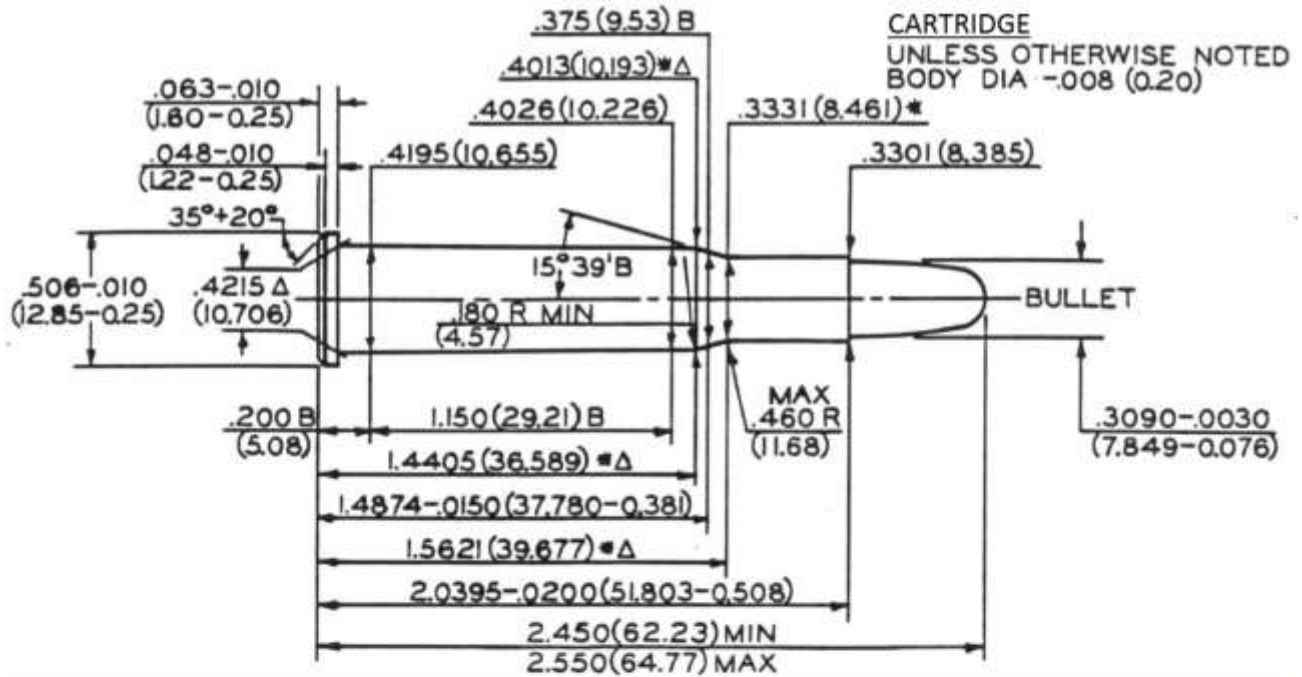

NOTE
 B = BASIC
 (XX.XX) = MILLIMETERS
 ⊗ = HEADSPACE DIMENSION
 Δ = REFERENCE DIMENSION
 * DIMENSIONS ARE TO INTERSECTION OF LINES
 ALL CALCULATIONS APPLY AT MAXIMUM MATERIAL CONDITION (MMC)

NOTICE: This drawing is subject to change.
 Current version is available at www.saami.org.

MAXIMUM CARTRIDGE / MINIMUM CHAMBER

30-40 KRAG

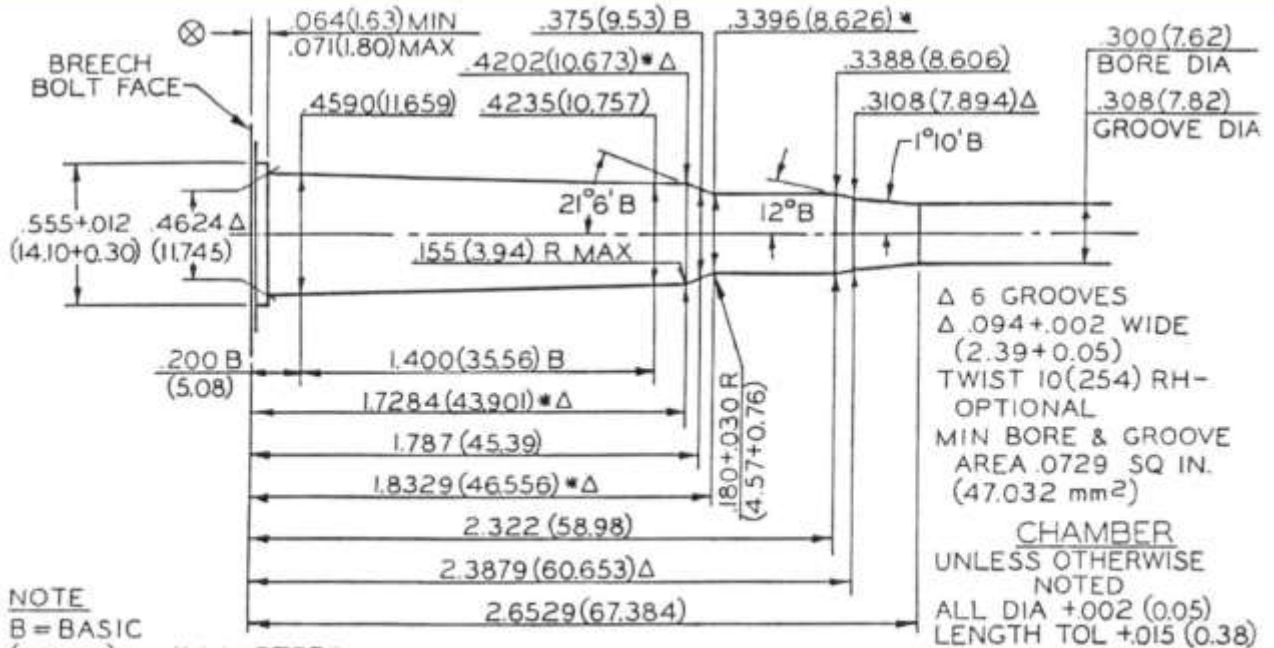
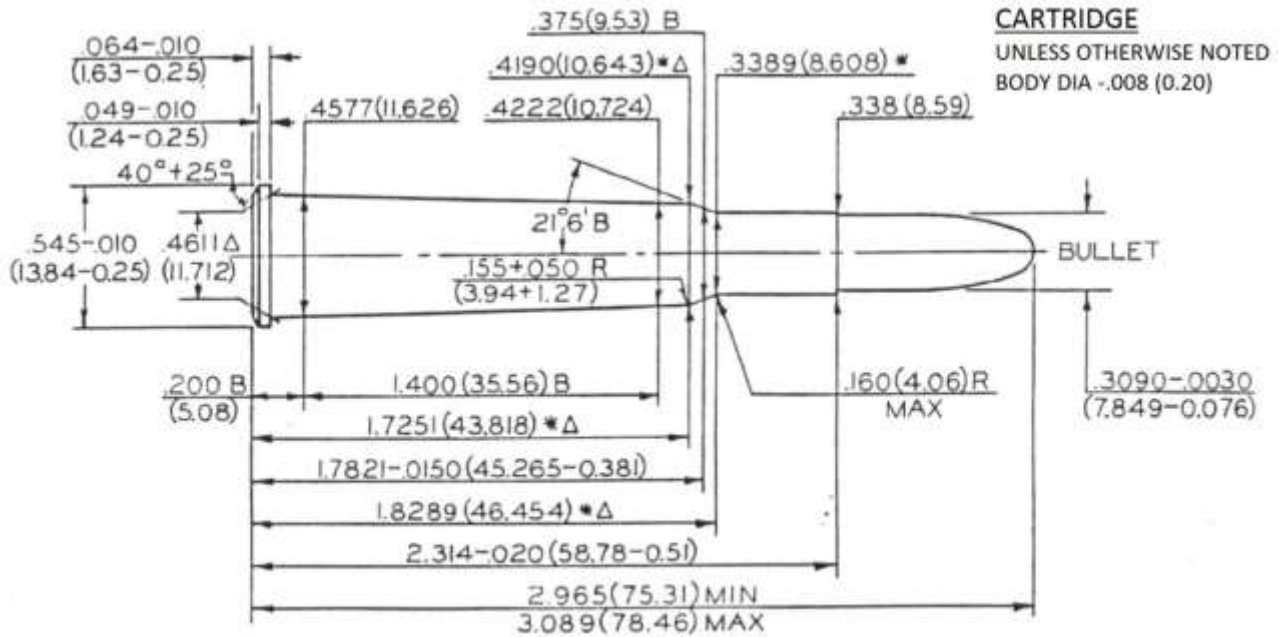

NOTICE: This drawing is subject to change.
 Current version is available at www.saami.org.

MAXIMUM CARTRIDGE / MINIMUM CHAMBER

300 AAC BLACKOUT

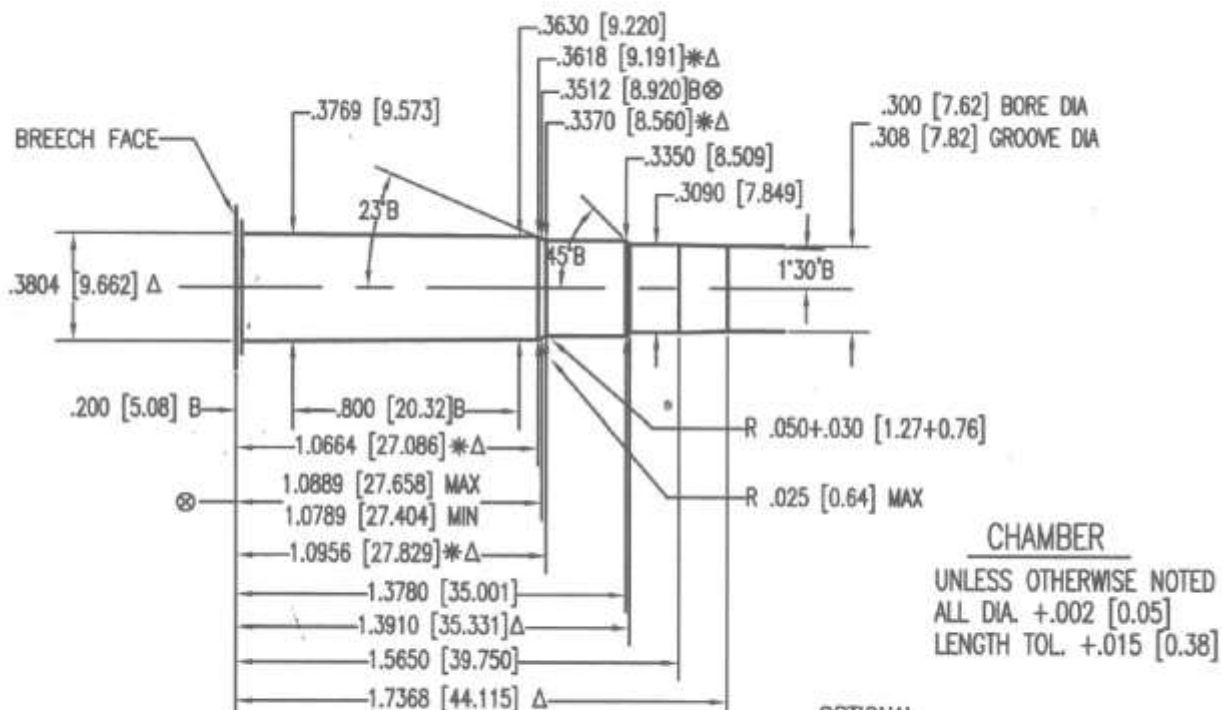
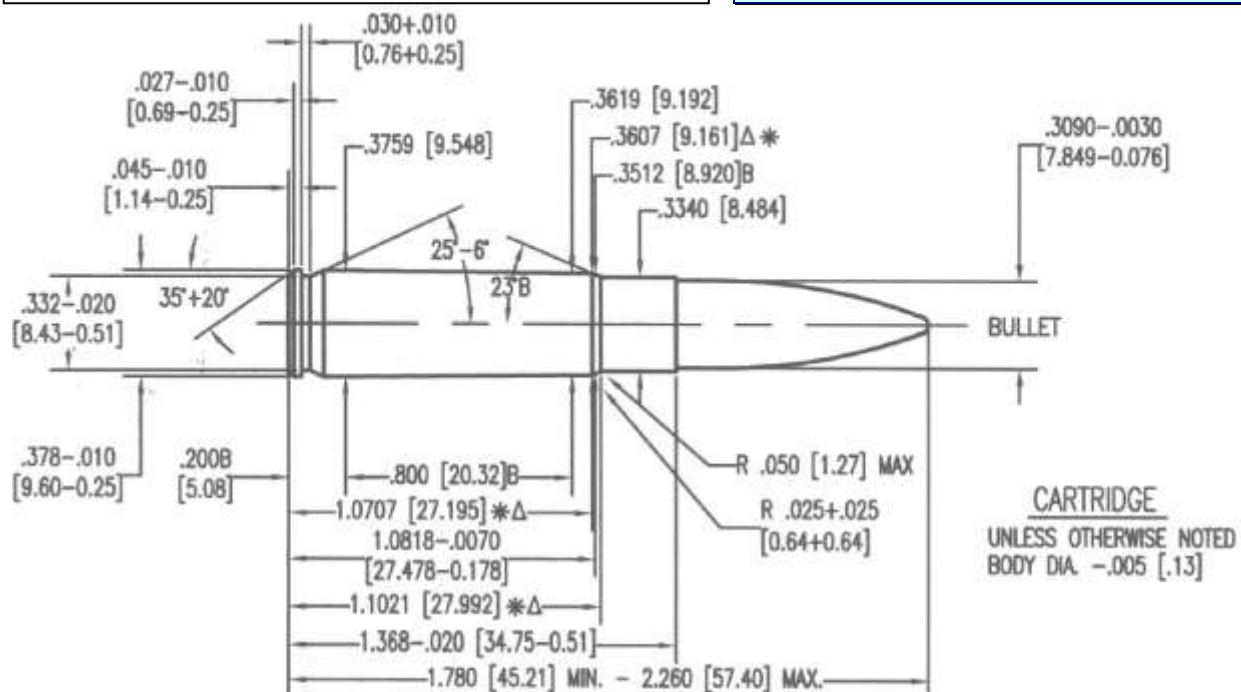

NOTE:
 B=BASIC
 [XX.XX]=MILLIMETERS
 ⊗ = HEADSPACE DIMENSION
 Δ = REFERENCE DIMENSION
 * DIMENSIONS ARE TO INTERSECTION OF LINES
 ALL CALCULATIONS APPLY AT MAXIMUM MATERIAL CONDITION (MMC)

OPTIONAL:
 Δ5 GROOVES
 Δ.146+.002 [3.71+0.05] WIDE
 TWIST: 8 [203.2] R.H.

MIN. BORE & GROOVE
 AREA: .0737 SQ. IN. [47.548 mm²]

NOTICE: This drawing is subject to change.
 Current version is available at www.saami.org.

MAXIMUM CARTRIDGE / MINIMUM CHAMBER

300 H&H MAGNUM

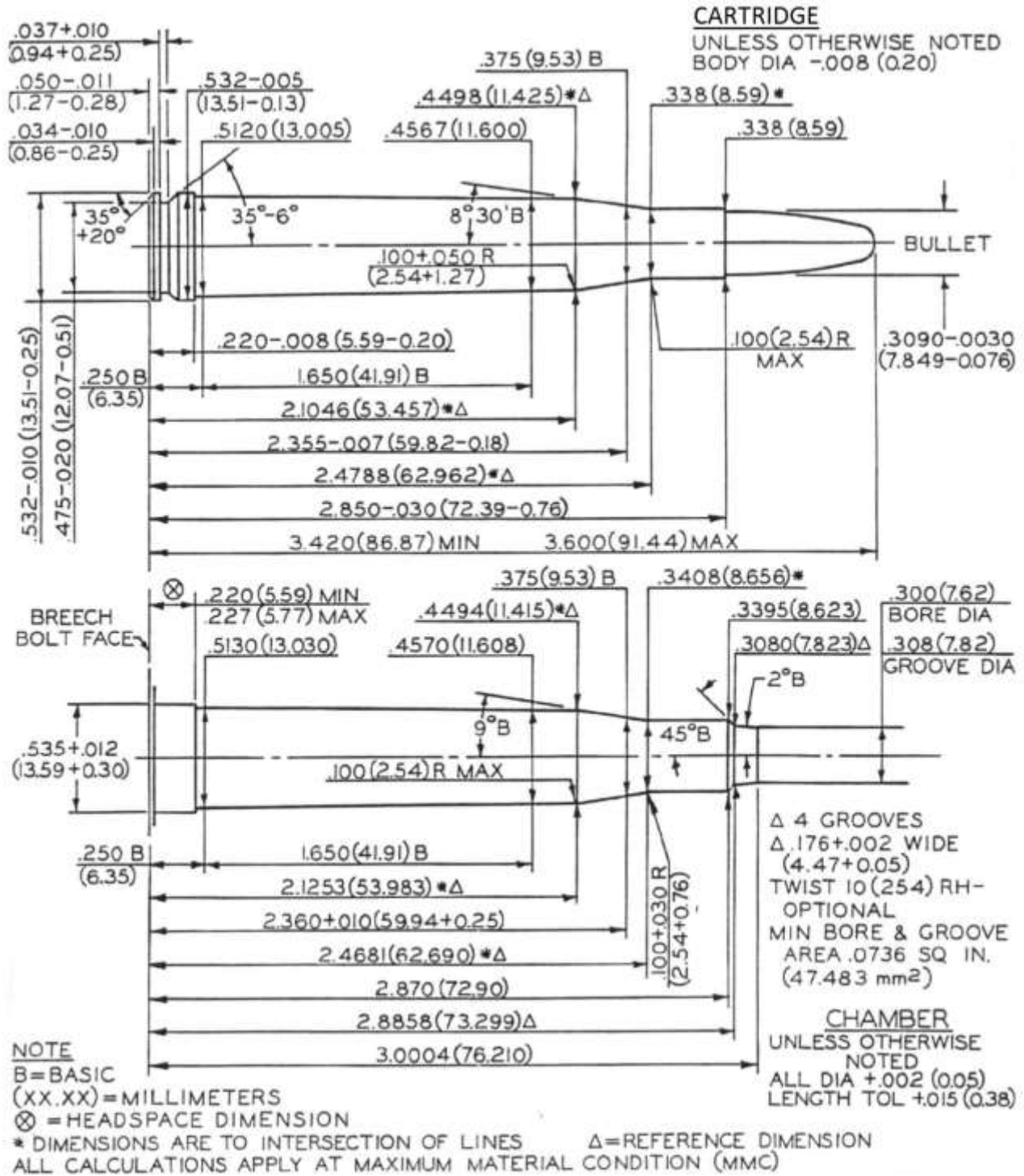

NOTICE: This drawing is subject to change.
 Current version is available at www.saami.org.

MAXIMUM CARTRIDGE / MINIMUM CHAMBER

**300 REMINGTON SHORT ACTION
 ULTRA MAGNUM**

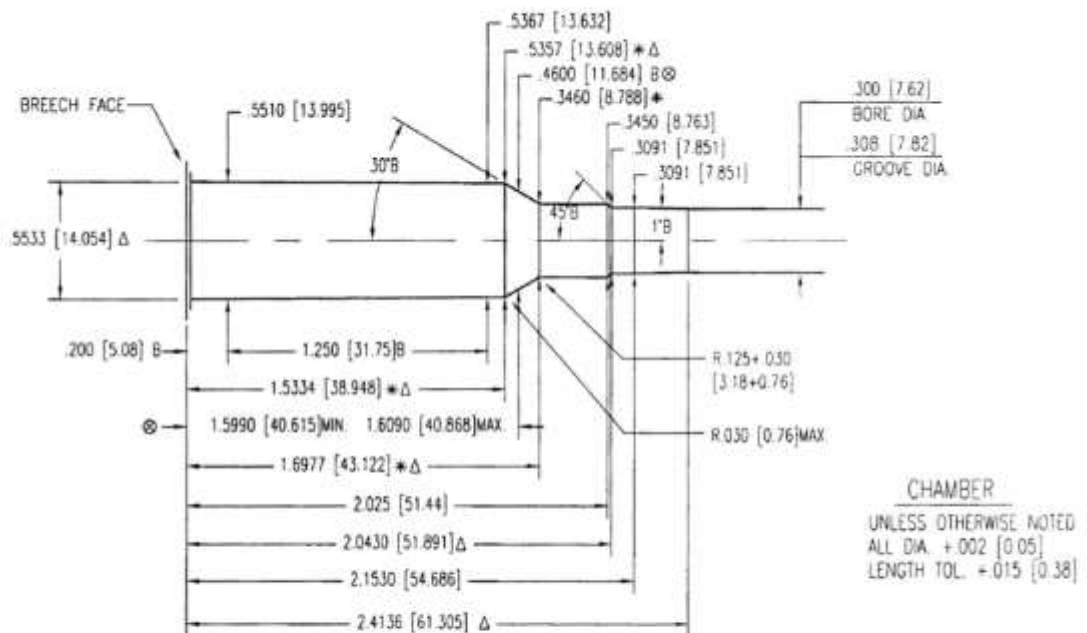
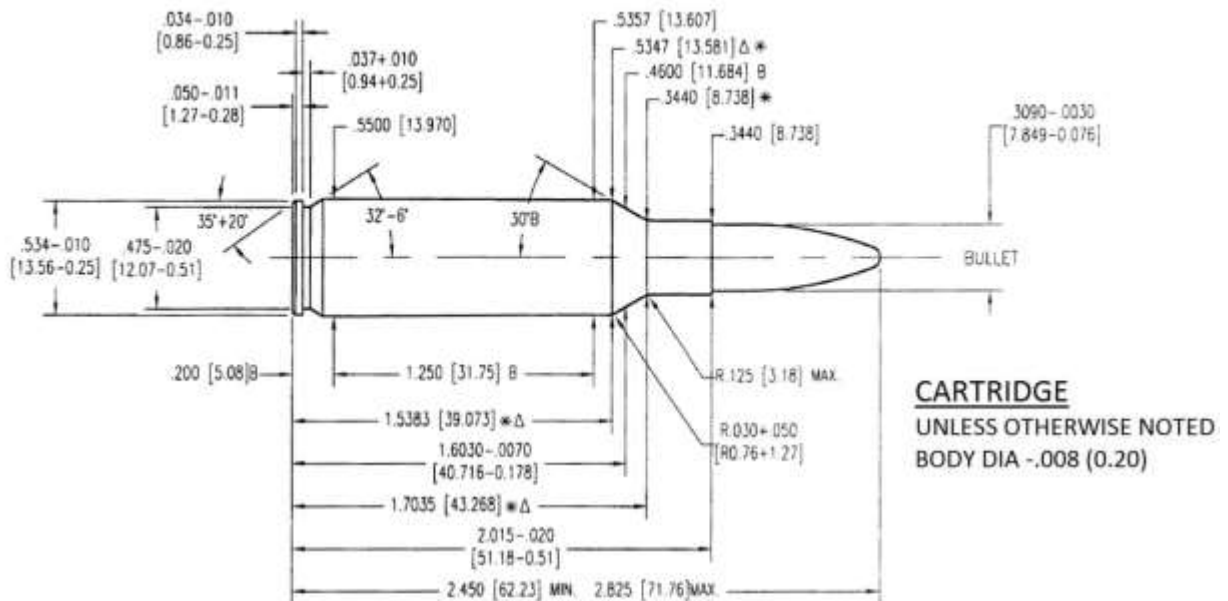

NOTE:
 B=BASIC
 [XX.XX]=MILLIMETERS
 ⊕ = HEADSPACE DIMENSION
 Δ = REFERENCE DIMENSION
 * DIMENSIONS ARE TO INTERSECTION OF LINES
 ALL CALCULATIONS APPLY AT MAXIMUM MATERIAL CONDITION (MMC)

Δ 6 GROOVES
 Δ .110+.002 [2.79+0.05] WIDE
 TWIST 10[254] R.H. OPTIONAL
 MIN. BORE & GROOVE
 AREA: .0733 SQ. IN. [47.290 mm²]

NOTICE: This drawing is subject to change.
 Current version is available at www.saami.org.

MAXIMUM CARTRIDGE / MINIMUM CHAMBER
300 REMINGTON ULTRA MAGNUM

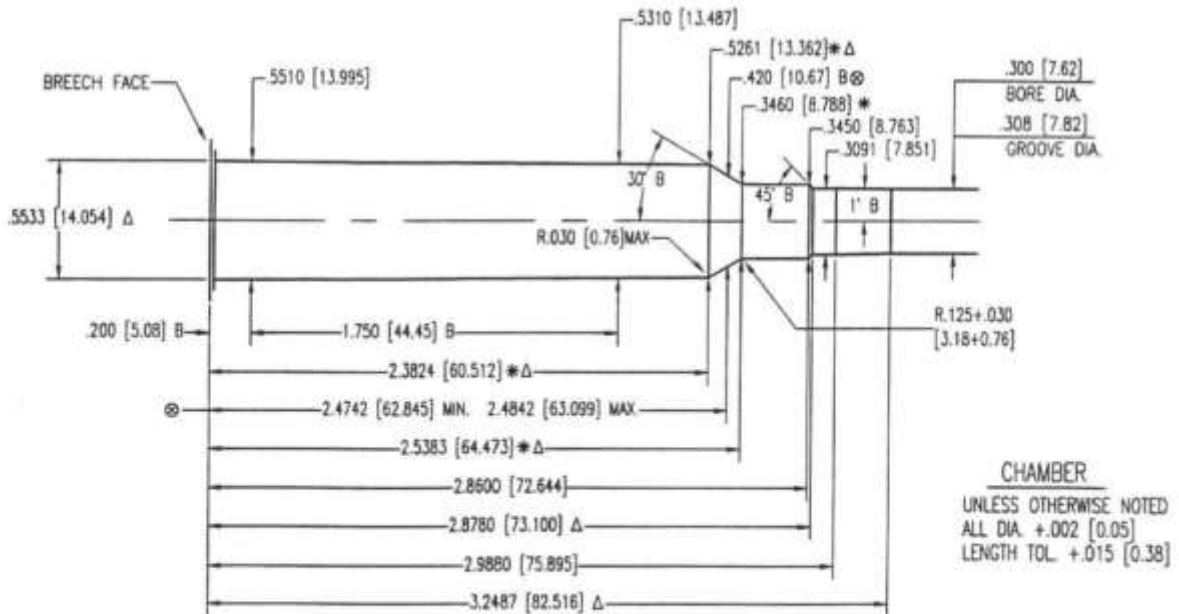
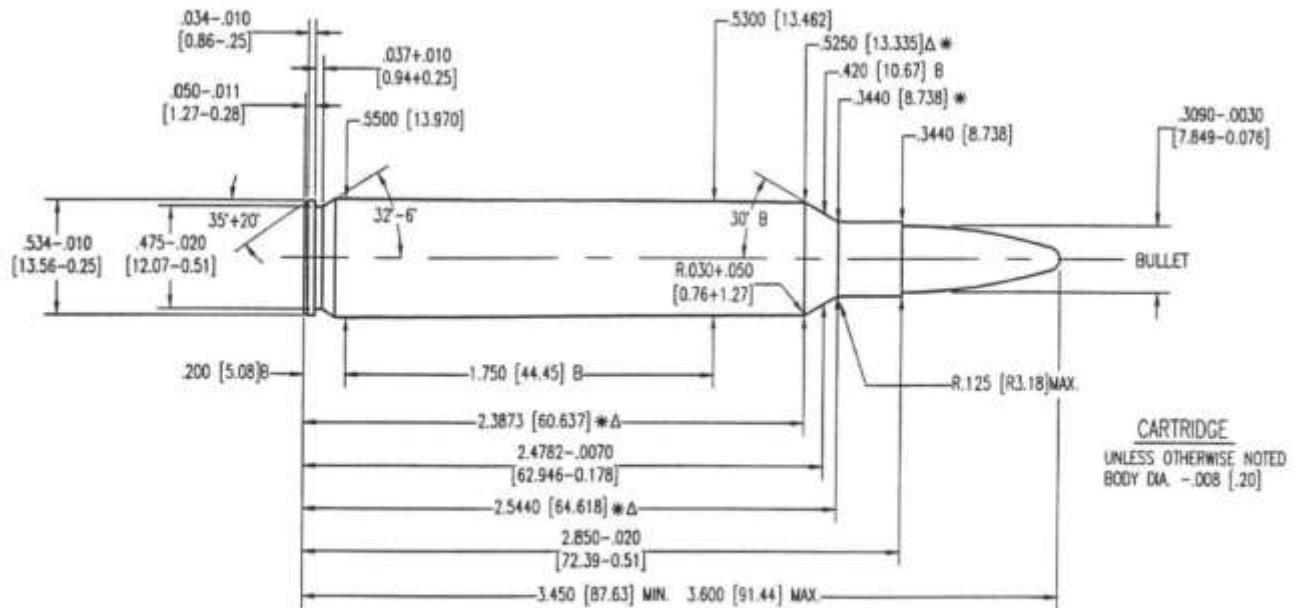

NOTE:
 B=BASIC
 [XX.XX]=MILLIMETERS
 ⊕ = HEADSPACE DIMENSION
 Δ = REFERENCE DIMENSION
 * DIMENSIONS ARE TO INTERSECTION OF LINES
 ALL CALCULATIONS APPLY AT MAXIMUM MATERIAL CONDITION (MMC)

Δ 6 GROOVES
 Δ .115+.002 [2.92+0.05] WIDE
 TWIST: 10[254] R.H. OPTIONAL
 MIN. BORE & GROOVE
 AREA: .0735 SQ. IN. [47.419 mm²]

NOTICE: This drawing is subject to change.
 Current version is available at www.saami.org.

MAXIMUM CARTRIDGE / MINIMUM CHAMBER
300 RUGER COMPACT MAGNUM

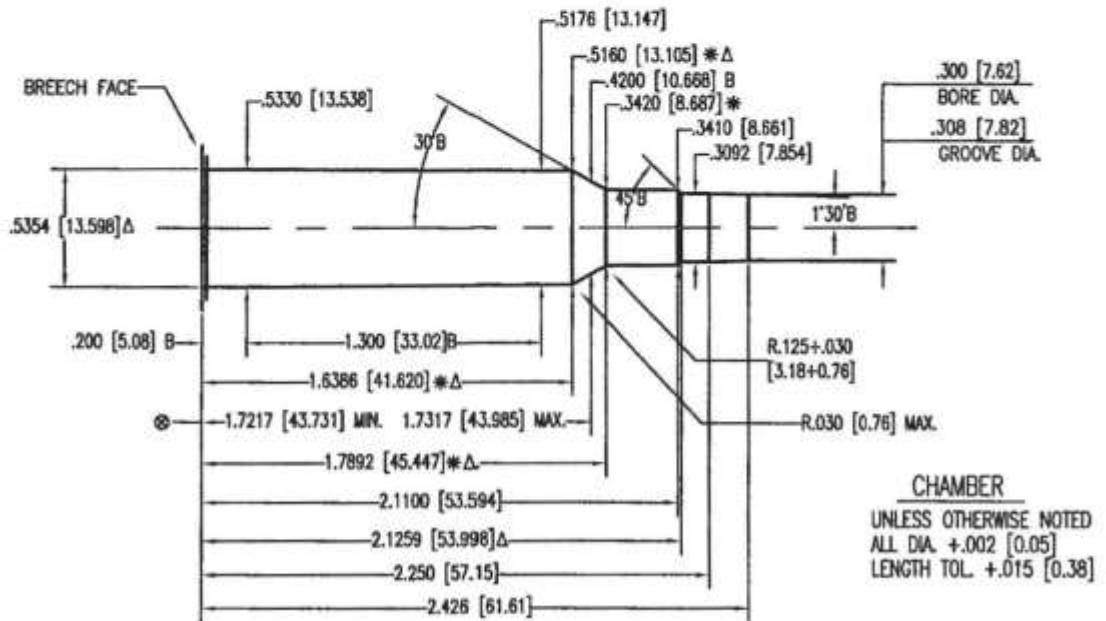
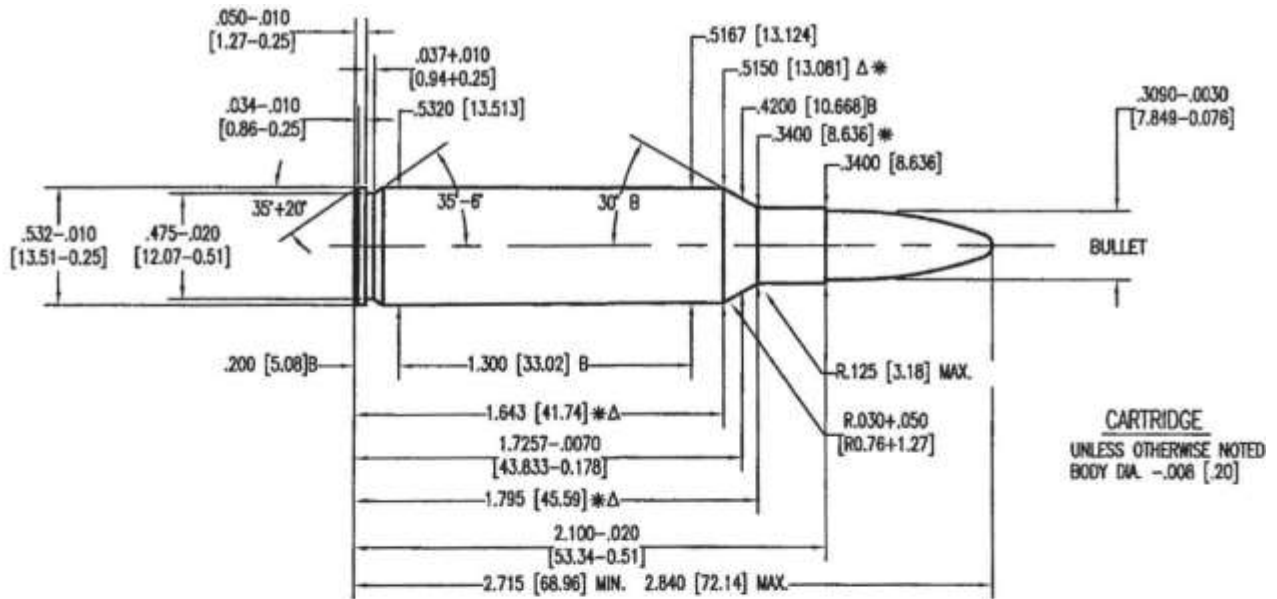

NOTE:
 B=BASIC
 [XX.XX]=MILLIMETERS
 ⊕ = HEADSPACE DIMENSION
 Δ = REFERENCE DIMENSION
 * DIMENSIONS ARE TO INTERSECTION OF LINES
 ALL CALCULATIONS APPLY AT MAXIMUM MATERIAL CONDITION (MMC)

Δ 6 GROOVES
 Δ .110 $+.002$ [2.79+0.05] WIDE
 TWIST: 10[254] R.H. OPTIONAL
 MIN. BORE & GROOVE
 AREA: .0733 SQ. IN. [47.290 mm²]

NOTICE: This drawing is subject to change.
 Current version is available at www.saami.org.

MAXIMUM CARTRIDGE / MINIMUM CHAMBER

300 SAVAGE

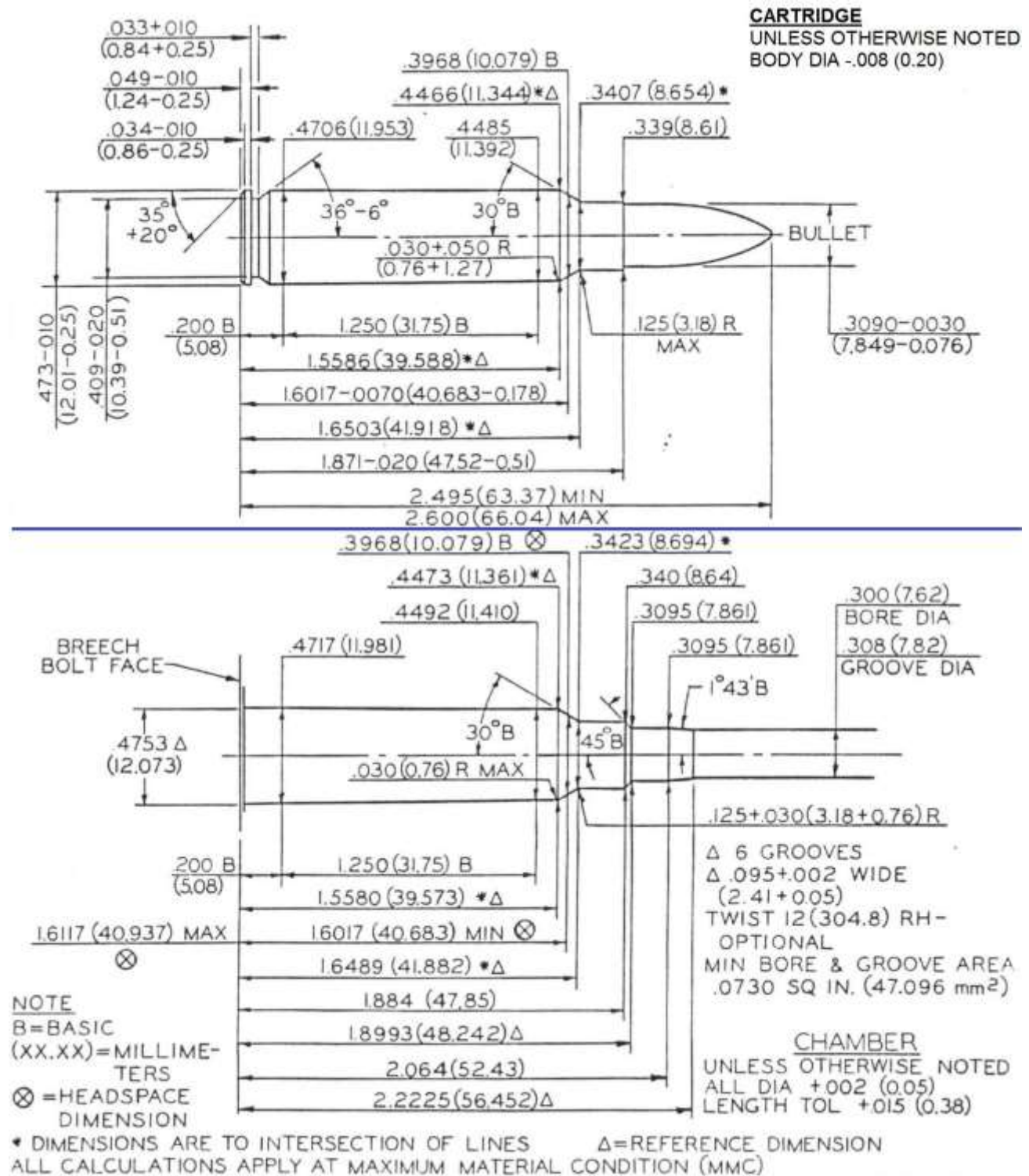

NOTICE: This drawing is subject to change.
 Current version is available at www.saami.org.

MAXIMUM CARTRIDGE / MINIMUM CHAMBER
300 WEATHERBY MAGNUM

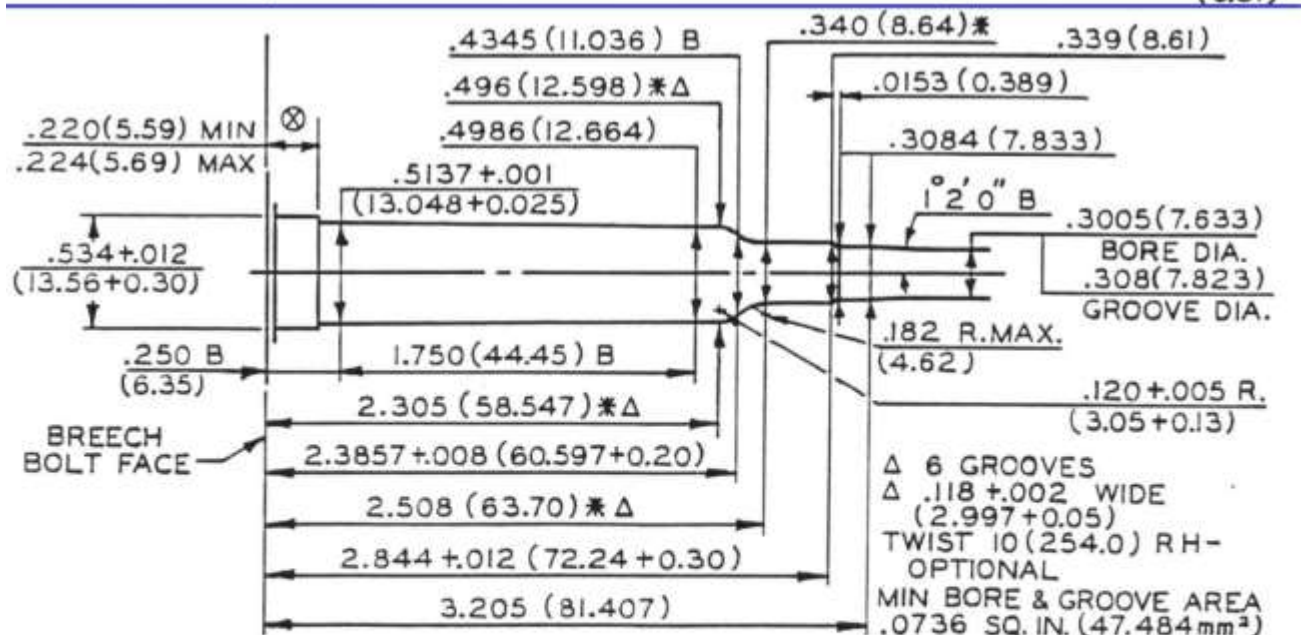
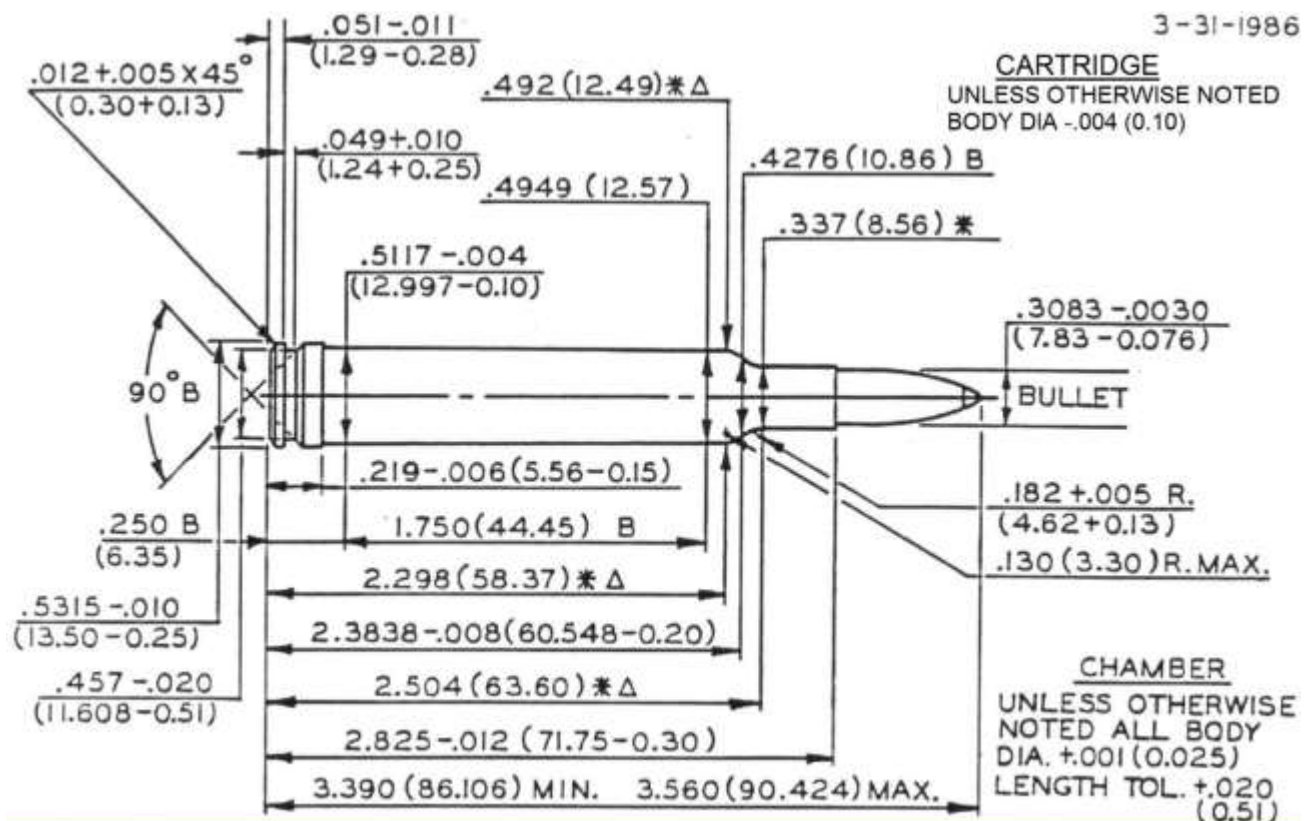

NOTE
 B=BASIC
 (XX.XX)=MILLIMETERS
 ⊗=HEADSPACE DIMENSION
 * DIMENSIONS ARE TO INTERSECTION OF LINES
 Δ REFERENCE DIMENSION
 ALL CALCULATIONS APPLY AT MAXIMUM MATERIAL
 CONDITION (MMC)

NOTICE: This drawing is subject to change.
 Current version is available at www.saami.org.

MAXIMUM CARTRIDGE / MINIMUM CHAMBER

300 WINCHESTER MAGNUM

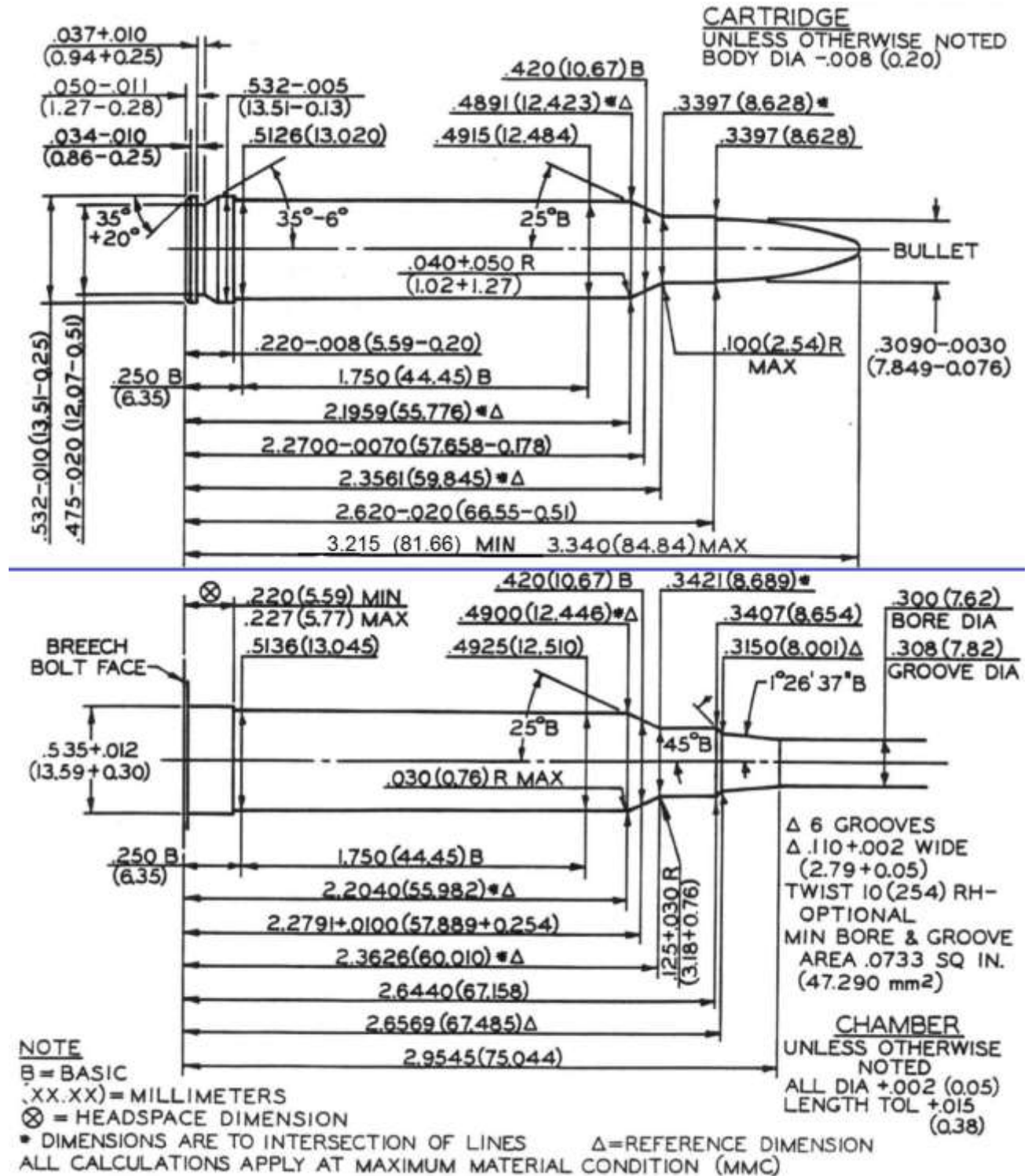

NOTICE: This drawing is subject to change.
 Current version is available at www.saami.org.

MAXIMUM CARTRIDGE / MINIMUM CHAMBER
300 WINCHESTER SHORT MAGNUM

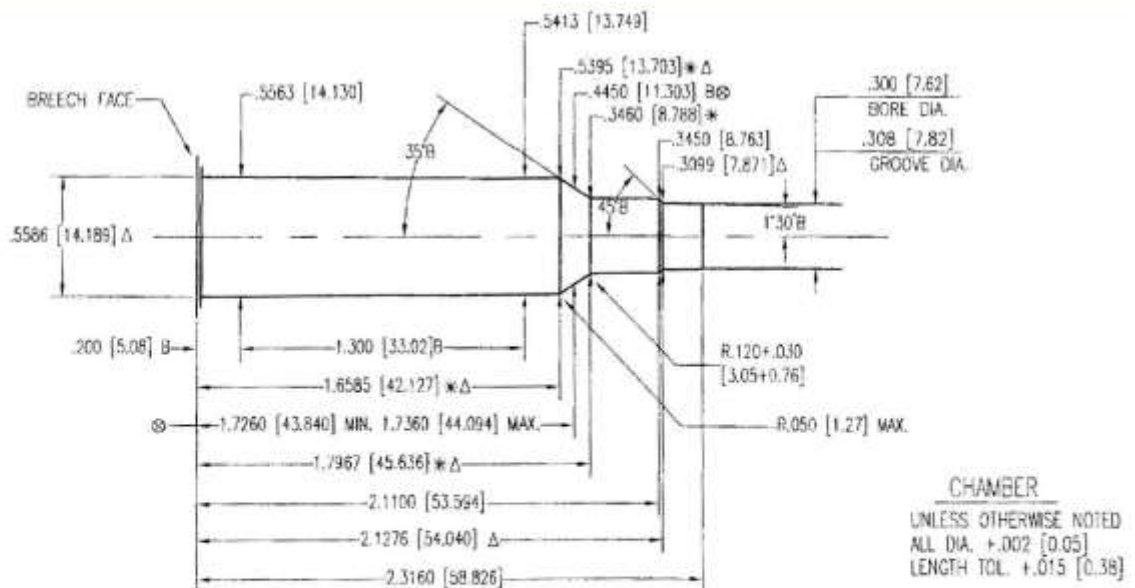
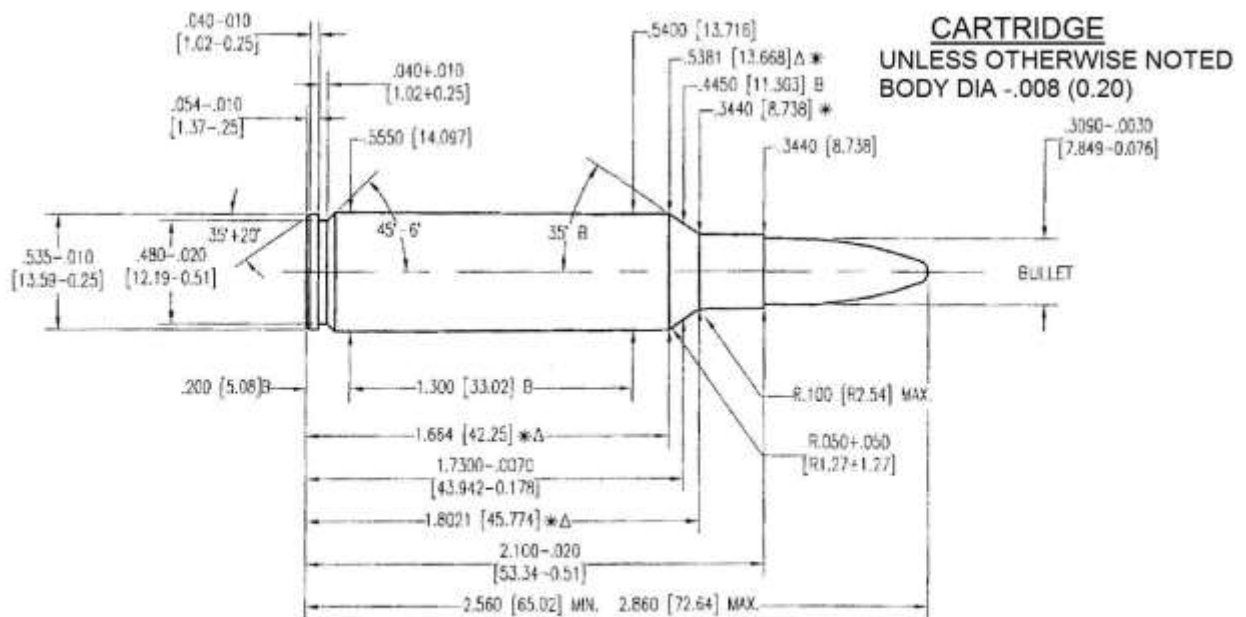

NOTE:
 B=BASIC
 [XX.XX]=MILLIMETERS
 ⊕ = HEADSPACE DIMENSION
 Δ = REFERENCE DIMENSION
 * DIMENSIONS ARE TO INTERSECTION OF LINES
 ALL CALCULATIONS APPLY AT MAXIMUM MATERIAL CONDITION (MMC)

Δ 4 GROOVES
 Δ 1.767^{+0.0020} [4.488^{+0.051}] WIDE
 TWIST: 10 [254] R.H. OPTIONAL
 MIN. BORE & GROOVE
 AREA: .0737 SQ. IN. [47.548 mm²]

NOTICE: This drawing is subject to change.
 Current version is available at www.saami.org.

MAXIMUM CARTRIDGE / MINIMUM CHAMBER

303 BRITISH

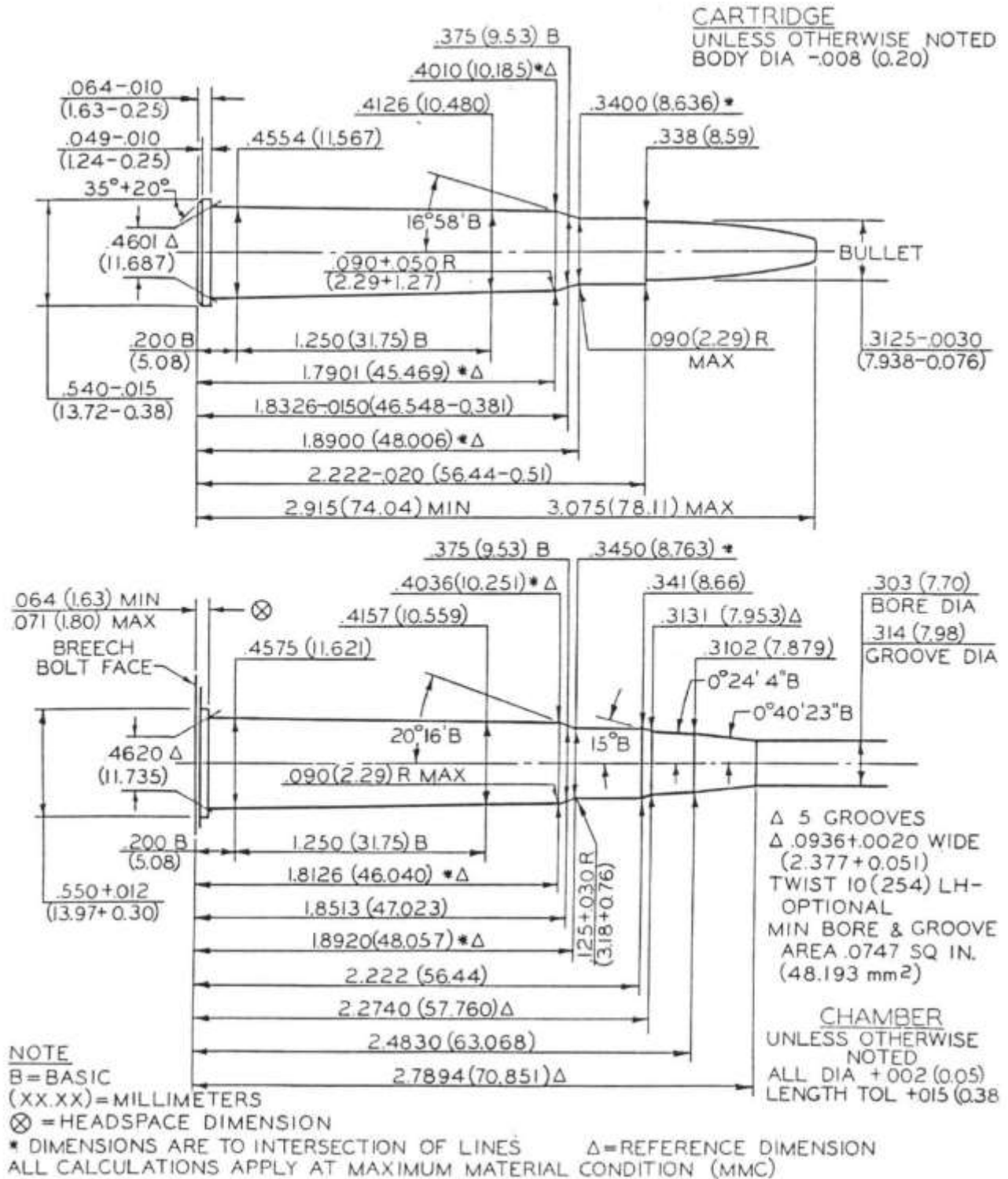

NOTICE: This drawing is subject to change.
 Current version is available at www.saami.org.

MAXIMUM CARTRIDGE / MINIMUM CHAMBER

307 WINCHESTER

11/08/1983

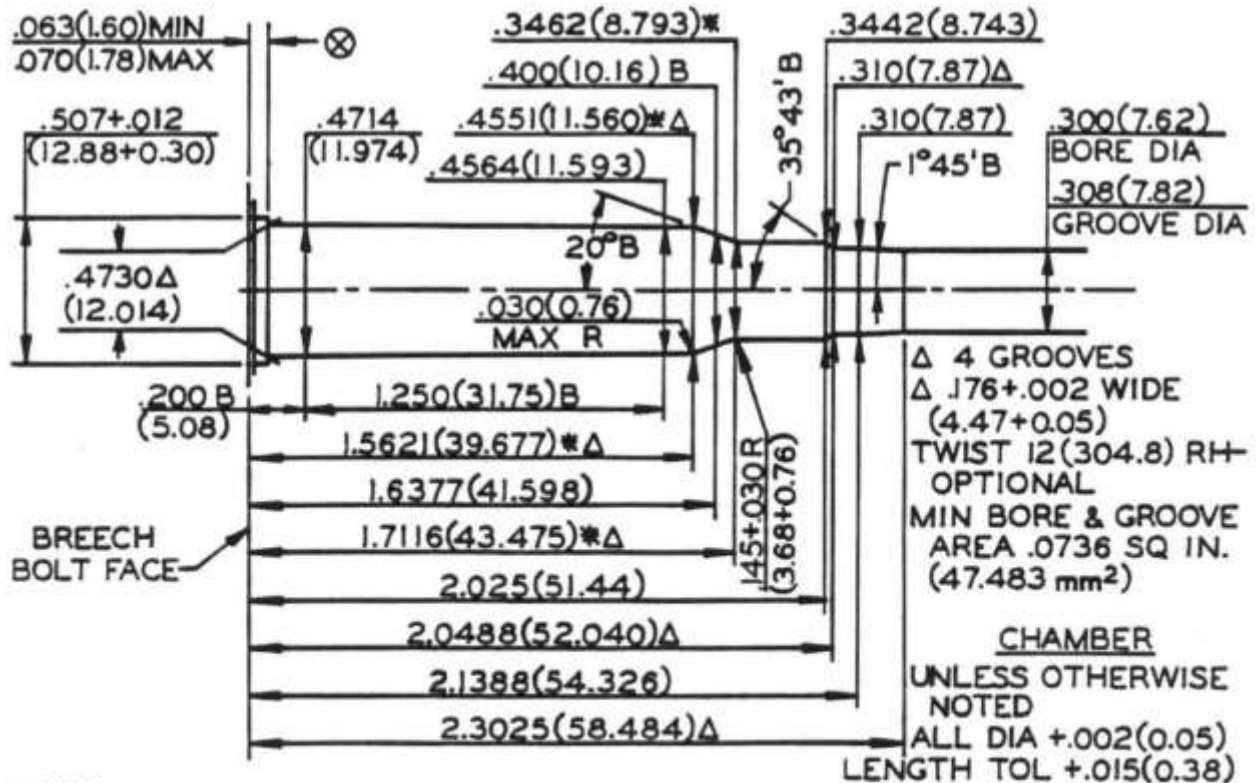
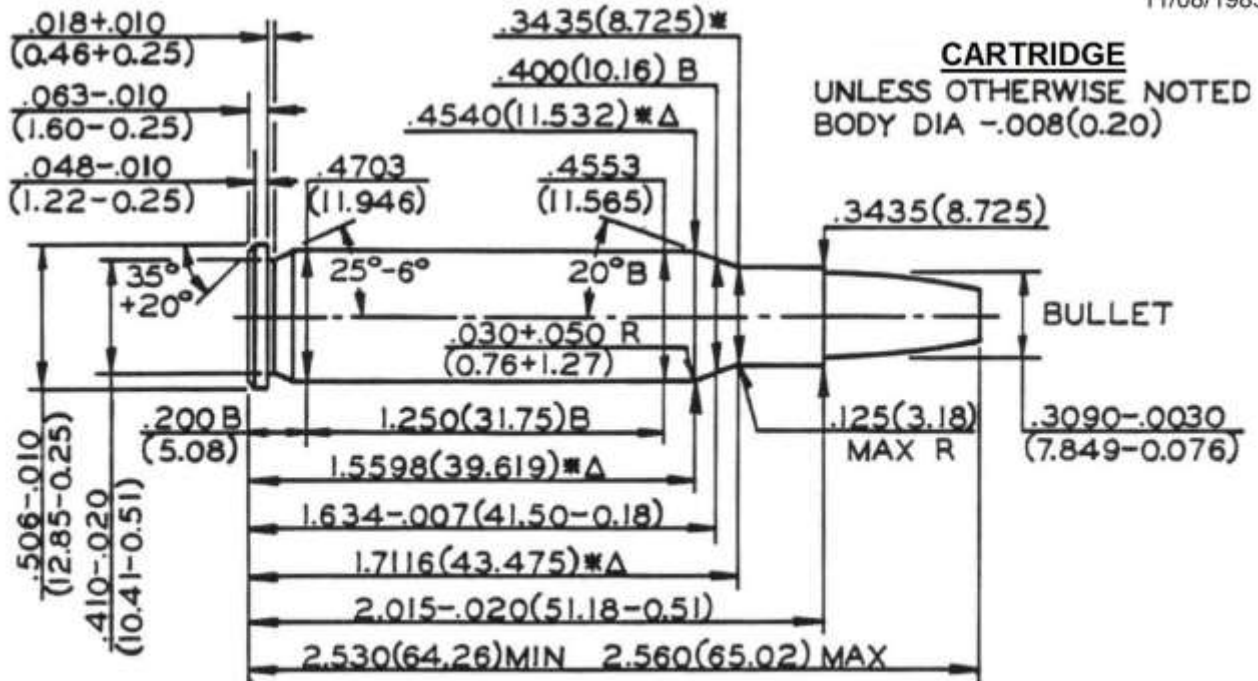

NOTE

B=BASIC Δ=REFERENCE DIMENSION ⊗=HEADSPACE DIMENSION
 * DIMENSIONS ARE TO INTERSECTION OF LINES (XX.XX)=MILLIMETERS
 ALL CALCULATIONS APPLY AT MAXIMUM MATERIAL CONDITION (MMC)

NOTICE: This drawing is subject to change.
 Current version is available at www.saami.org.

MAXIMUM CARTRIDGE / MINIMUM CHAMBER

308 MARLIN EXPRESS

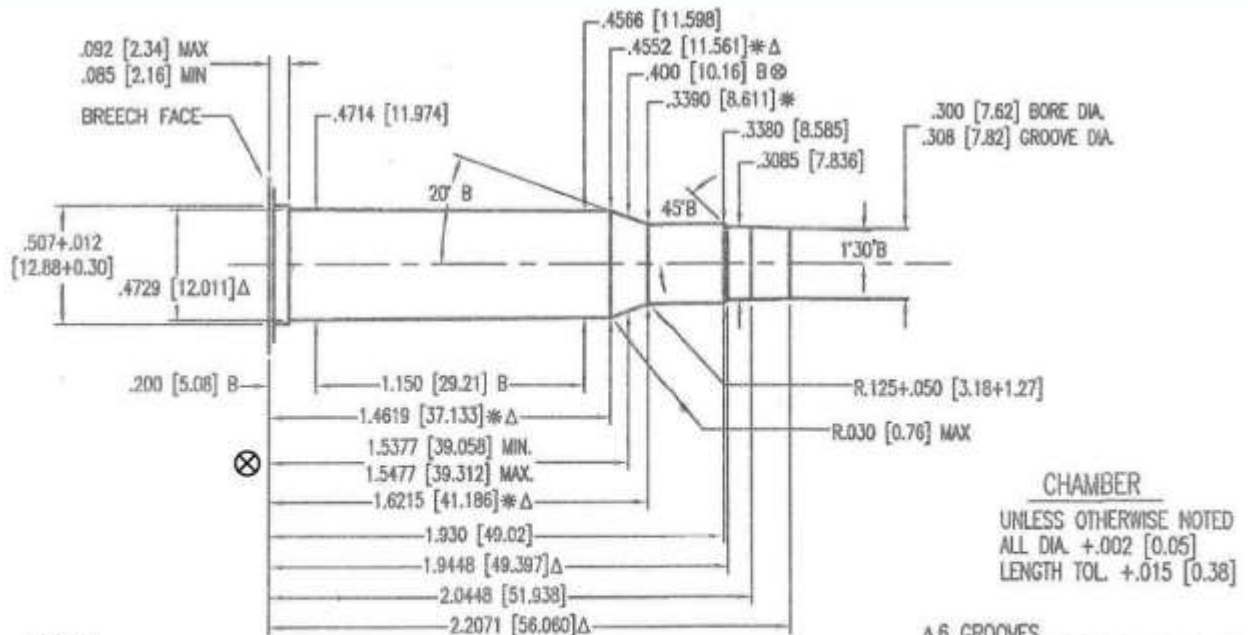
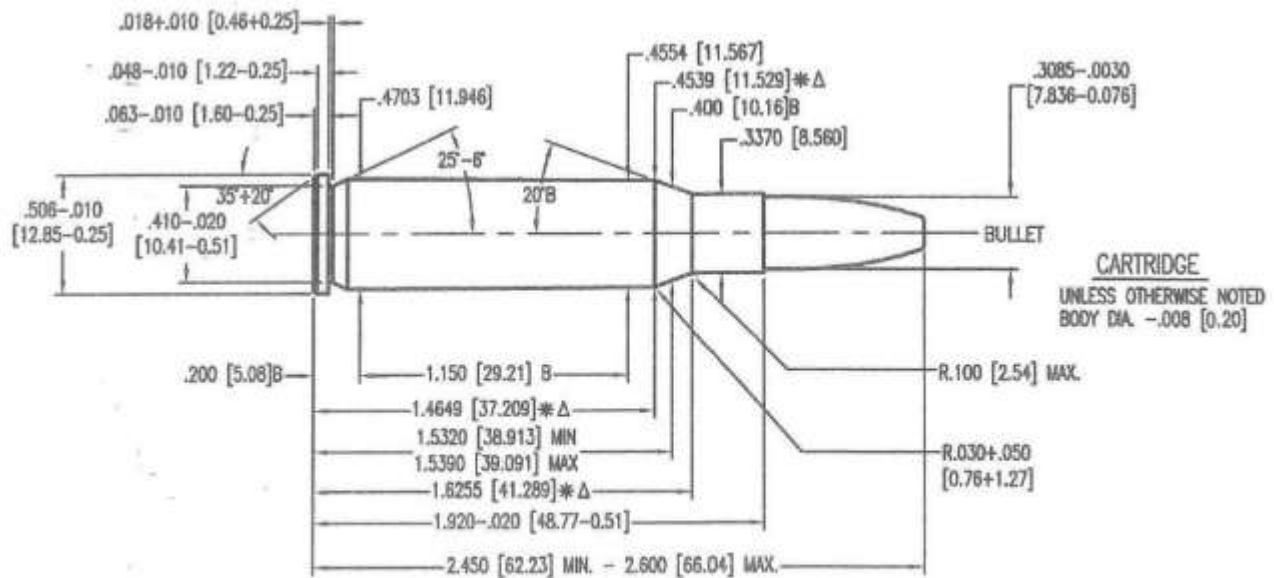

NOTE:
 B = BASIC
 ⊗ = HEADSPACE DIMENSION
 * DIMENSIONS ARE TO INTERSECTION OF LINES
 ALL CALCULATIONS APPLY AT MAXIMUM MATERIAL CONDITION (MMC)

(XX.XX) = MILLIMETERS
 Δ = REFERENCE DIMENSION

Δ 6 GROOVES
 Δ .0942+.0020 [2.393+0.051] WIDE
 TWIST: 12 [304.8] R.H. - OPTIONAL
 MIN. BORE & GROOVE AREA:
 .0729 SQ. IN. [47.032 mm²]

NOTICE: This drawing is subject to change.
 Current version is available at www.saami.org.

MAXIMUM CARTRIDGE / MINIMUM CHAMBER

308 WINCHESTER

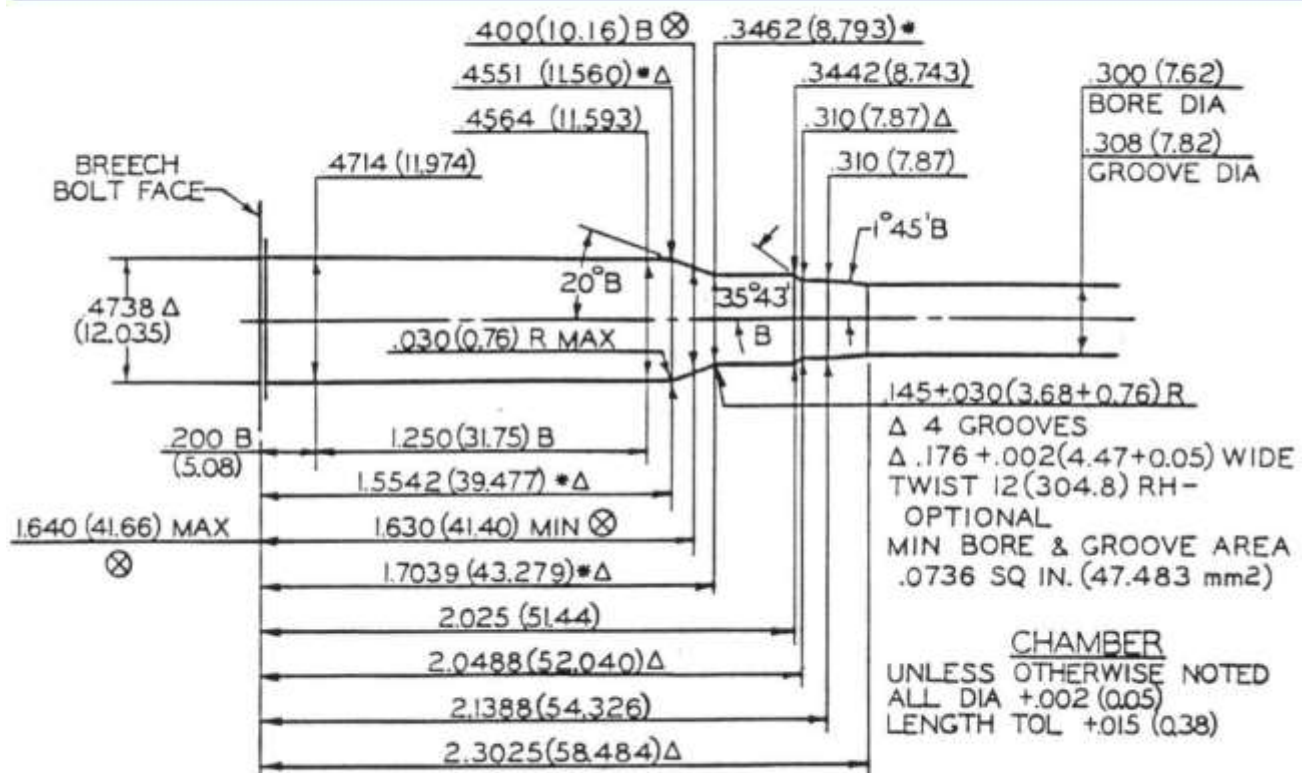
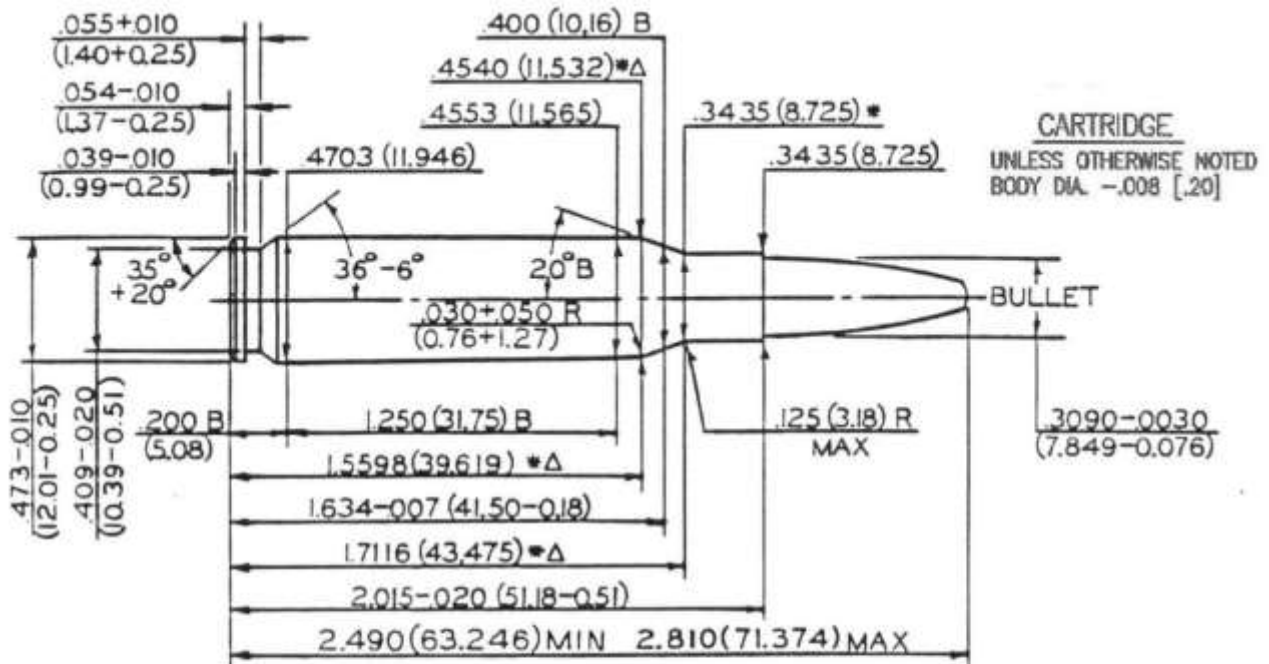

NOTE:
 B = BASIC
 ⊗ = HEADSPACE DIMENSION
 * DIMENSIONS ARE TO INTERSECTION OF LINES
 ALL CALCULATIONS APPLY AT MAXIMUM MATERIAL CONDITION (MMC)
 (XX.XX) = MILLIMETERS
 Δ = REFERENCE DIMENSION

NOTICE: This drawing is subject to change.
 Current version is available at www.saami.org.

MAXIMUM CARTRIDGE / MINIMUM CHAMBER

32 WINCHESTER SPECIAL

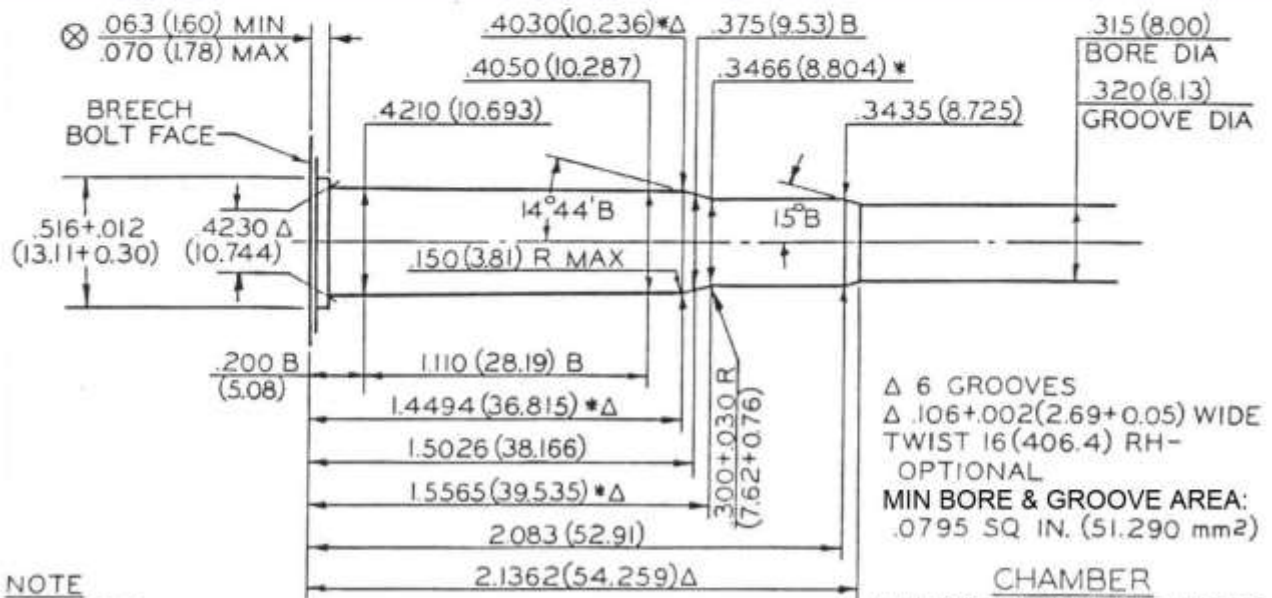
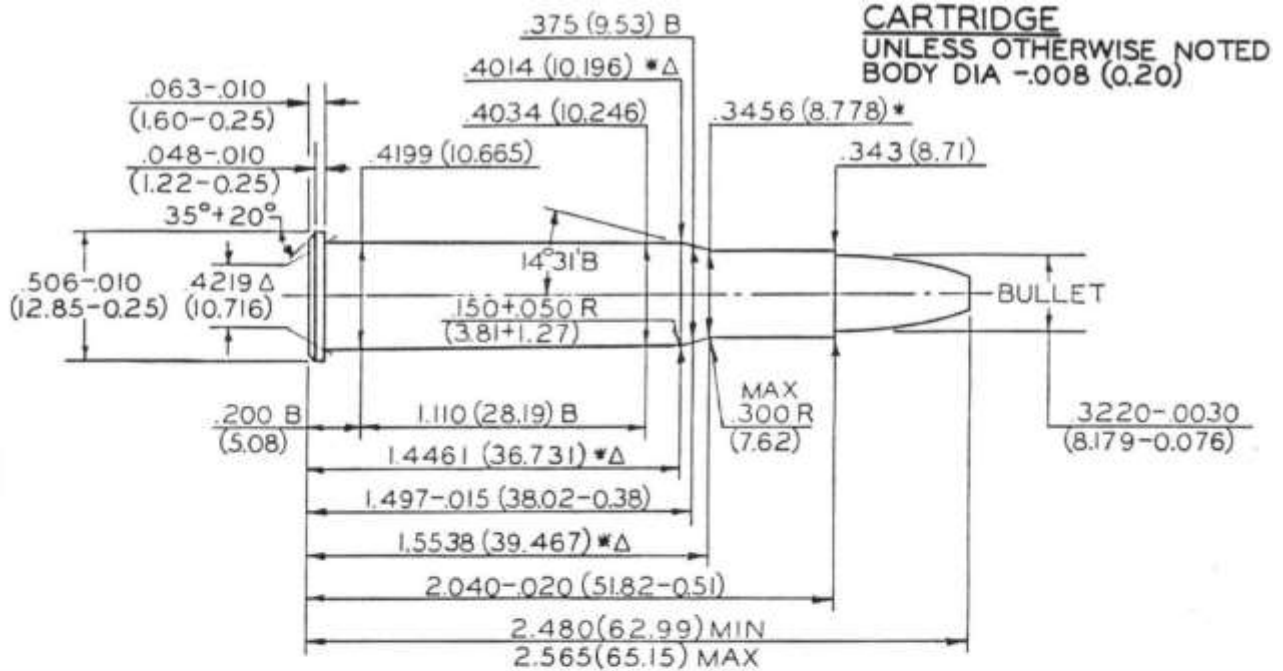

NOTE

- B = BASIC
- (XX.XX) = MILLIMETERS
- ⊗ = HEADSPACE DIMENSION
- Δ = REFERENCE DIMENSION
- * DIMENSIONS ARE TO INTERSECTION OF LINES
- ALL CALCULATIONS APPLY AT MAXIMUM MATERIAL CONDITION (MMC)

NOTICE: This drawing is subject to change.
 Current version is available at www.saami.org.

MAXIMUM CARTRIDGE / MINIMUM CHAMBER
325 WINCHESTER SHORT MAGNUM

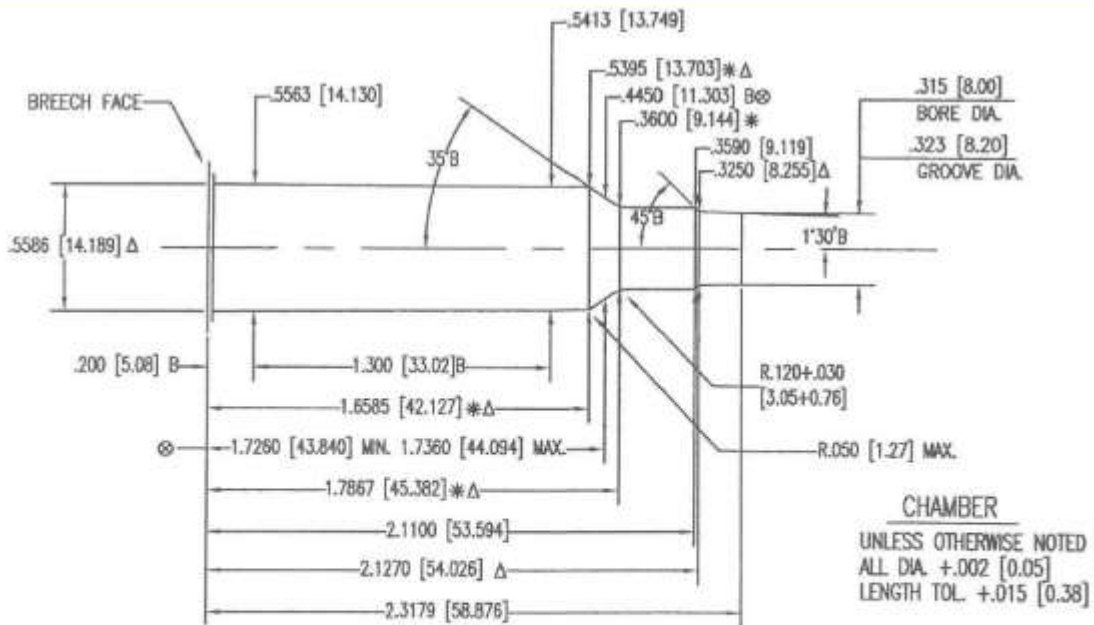
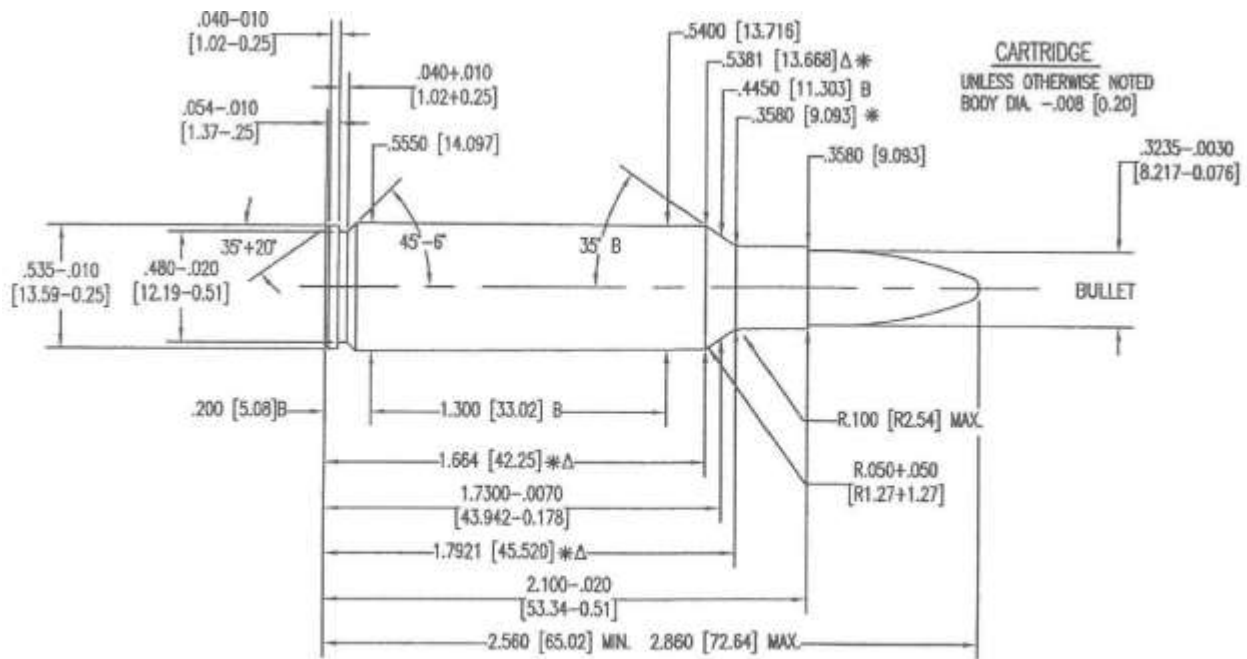

NOTE:
 B=BASIC
 [XX.XX]=MILLIMETERS
 ⊕ = HEADSPACE DIMENSION
 Δ = REFERENCE DIMENSION
 * DIMENSIONS ARE TO INTERSECTION OF LINES
 ALL CALCULATIONS APPLY AT MAXIMUM MATERIAL CONDITION (MMC)

CHAMBER
 UNLESS OTHERWISE NOTED
 ALL DIA. +.002 [0.05]
 LENGTH TOL. +.015 [0.38]

Δ 4 GROOVES
 Δ.1760+.0020 [4.470+0.051] WIDE
 TWIST: 10[254] R.H. OPTIONAL
 MIN. BORE & GROOVE
 AREA: .0809 SQ. IN. [52.193 mm²]

NOTICE: This drawing is subject to change.
 Current version is available at www.saami.org.

MAXIMUM CARTRIDGE / MINIMUM CHAMBER

33 NOSLER

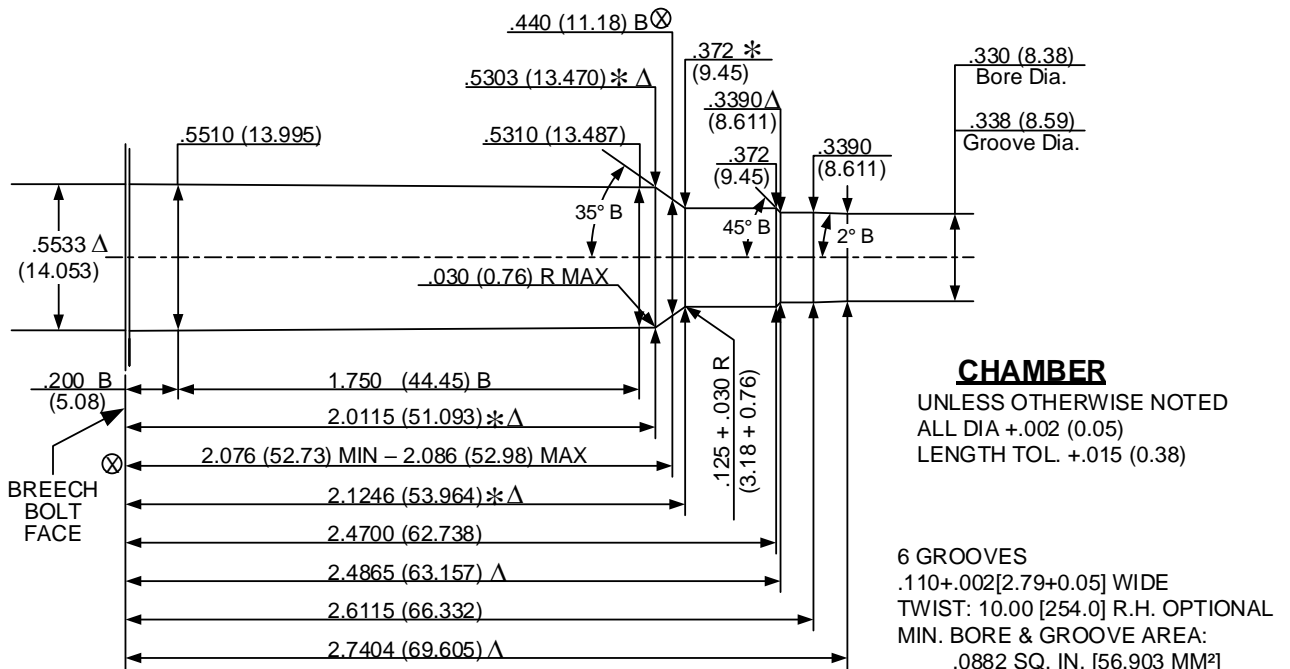
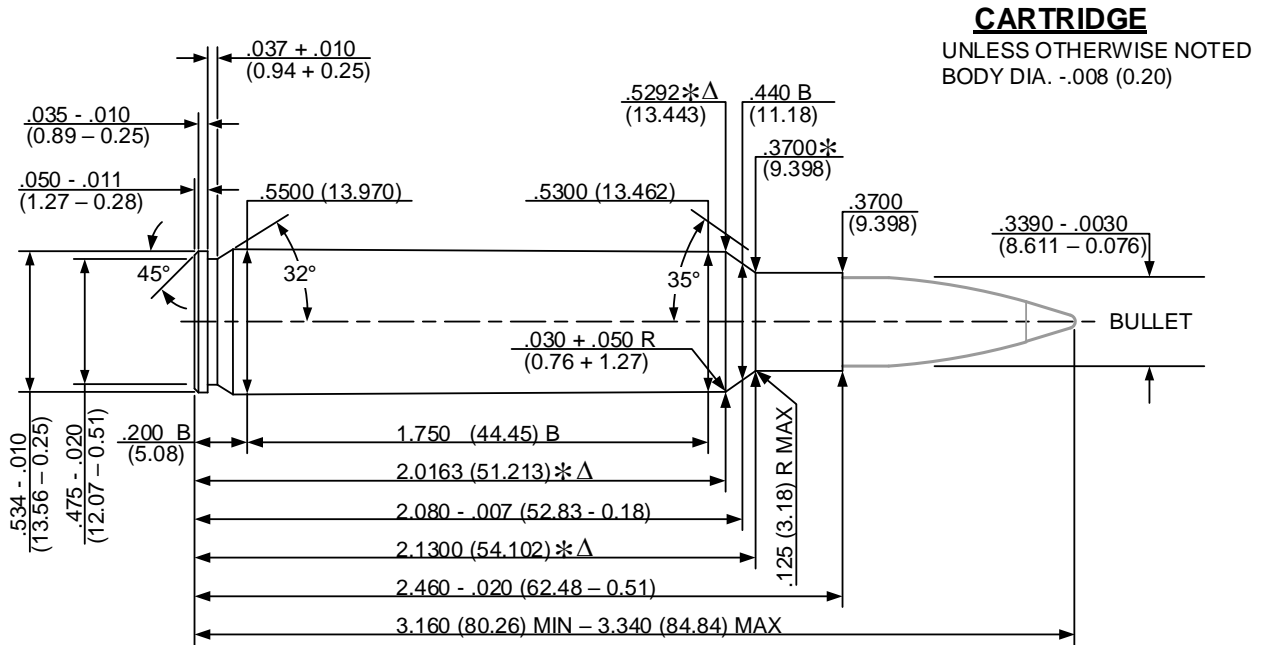

NOTE:
 B = BASIC
 (XX.XX) = MILLIMETERS
 ⊗ = HEAD SPACE DIMENSION
 Δ = REFERENCE DIMENSION
 * = DIMENSIONS ARE TO INTERSECTION OF LINES
 ALL CALCULATIONS APPLY AT MAXIMUM MATERIAL CONDITION (MMC)

NOTICE: This drawing is subject to change.
 Current version is available at www.saami.org.

MAXIMUM CARTRIDGE / MINIMUM CHAMBER

338 MARLIN EXPRESS

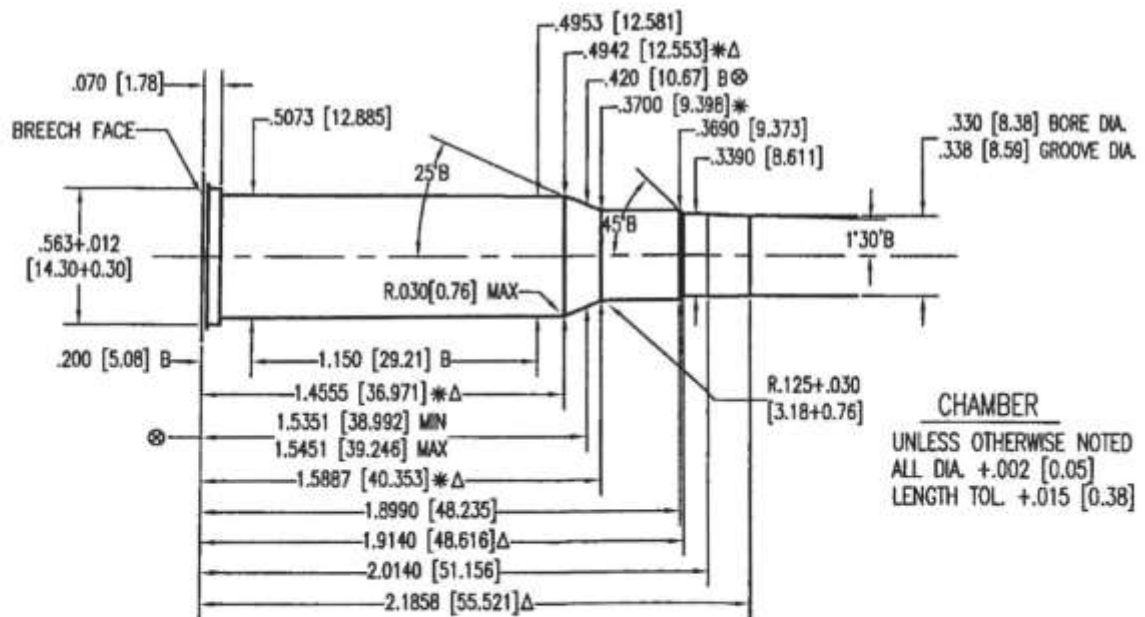
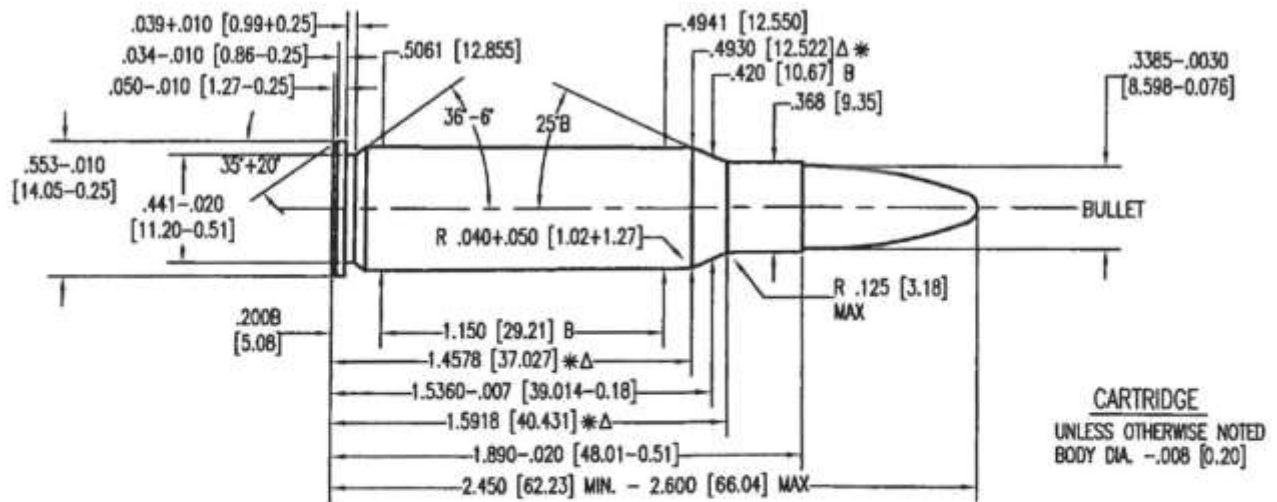

NOTE:
 B=BASIC
 [XX.XX]=MILLIMETERS
 ⊗ = HEADSPACE DIMENSION
 Δ = REFERENCE DIMENSION
 * DIMENSIONS ARE TO INTERSECTION OF LINES
 ALL CALCULATIONS APPLY AT MAXIMUM MATERIAL CONDITION (MMC)

OPTIONAL:
 Δ 6 GROOVES
 Δ $.110+0.002$ [2.79+0.05] WIDE
 TWIST: 12 [304.8] R.H.

MIN. BORE & GROOVE
 AREA: $.0882$ SQ. IN. [56.903 mm²]

NOTICE: This drawing is subject to change.
 Current version is available at www.saami.org.

MAXIMUM CARTRIDGE / MINIMUM CHAMBER
338 REMINGTON ULTRA MAGNUM

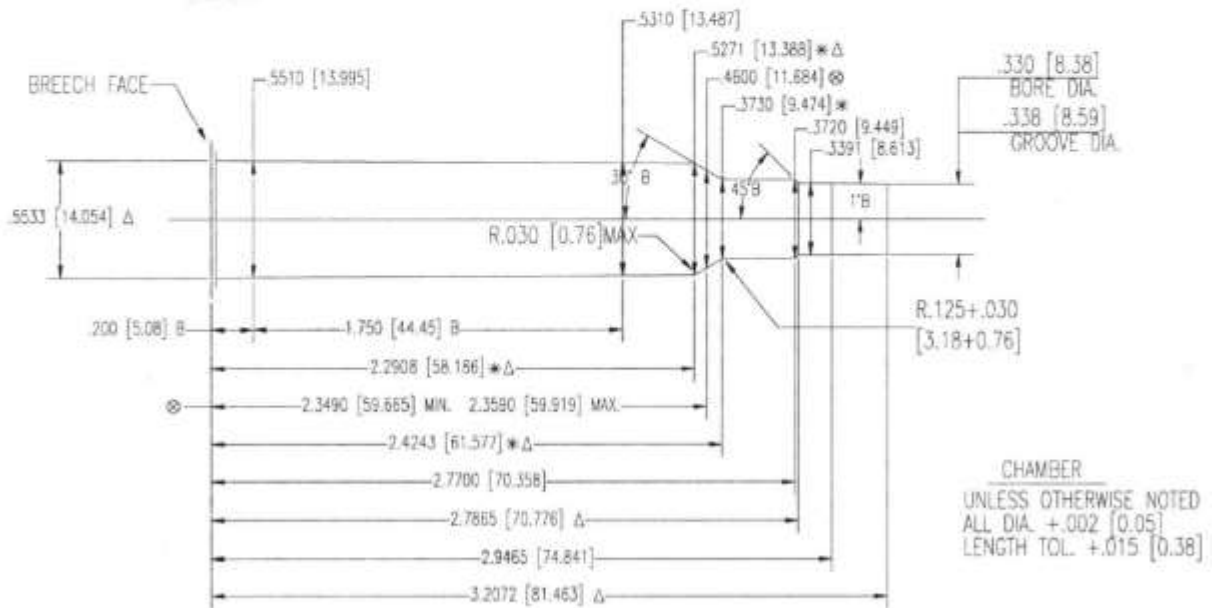
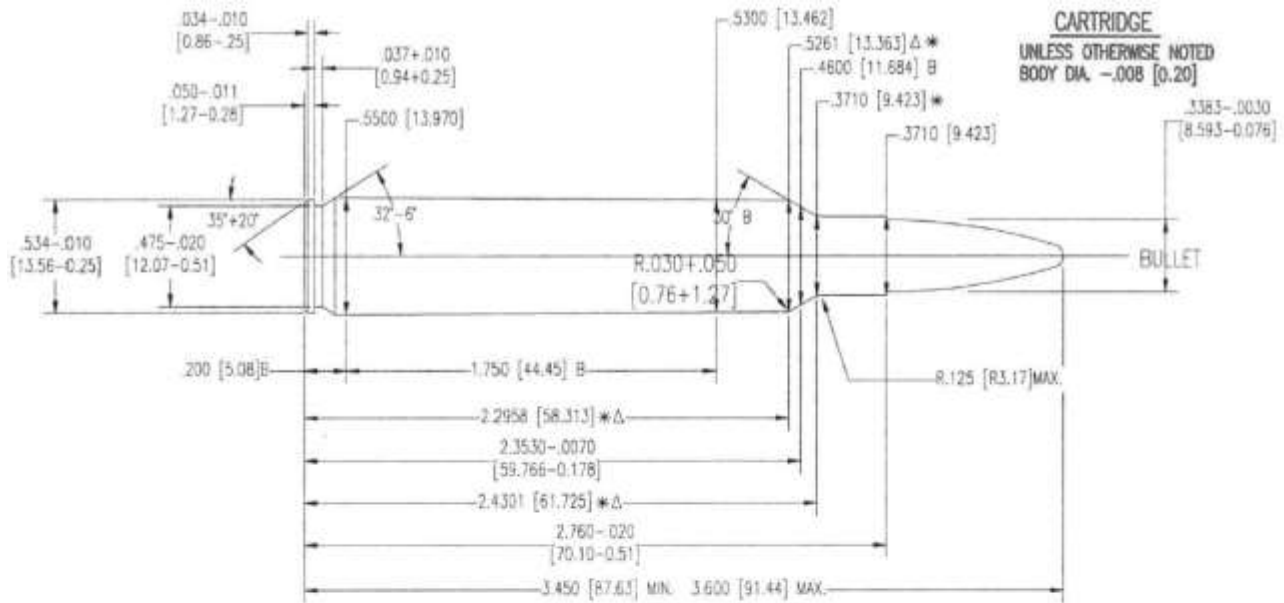

NOTE:
 B=BASIC
 [XX.XX]=MILLIMETERS
 ⊗ = HEADSPACE DIMENSION
 Δ = REFERENCE DIMENSION
 * DIMENSIONS ARE TO INTERSECTION OF LINES
 ALL CALCULATIONS APPLY AT MAXIMUM MATERIAL CONDITION (MMC)

Δ 6 GROOVES
 Δ.110±.002 [2.79±0.05] WIDE
 TWIST: 10[252] R.H. OPTIONAL
 MIN. BORE & GROOVE
 AREA: .0882 SQ. IN. [56.903 mm²]

NOTICE: This drawing is subject to change.
 Current version is available at www.saami.org.

MAXIMUM CARTRIDGE / MINIMUM CHAMBER
338 RUGER COMPACT MAGNUM

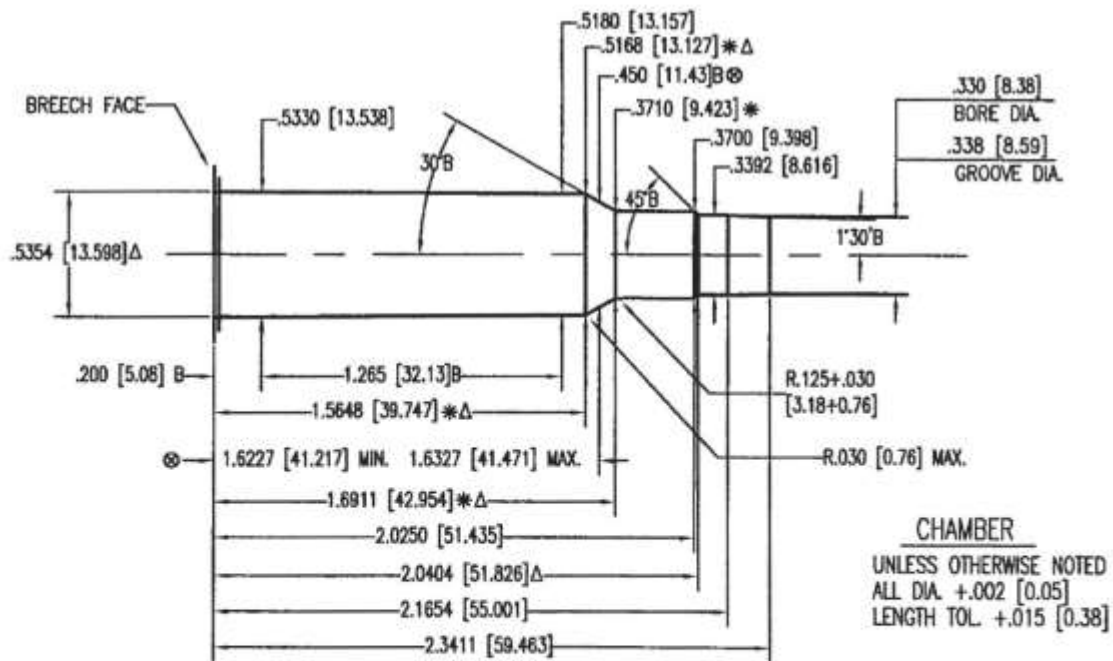
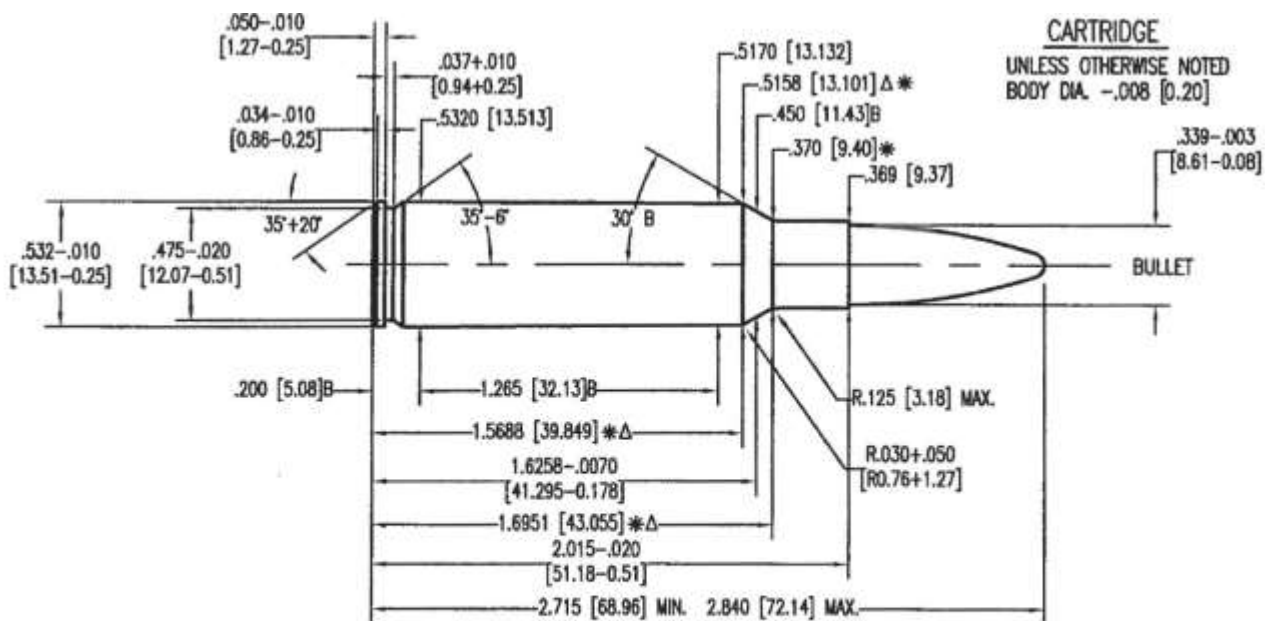

NOTE:
 B=BASIC
 [XX.XX]=MILLIMETERS
 ⊕ = HEADSPACE DIMENSION
 Δ = REFERENCE DIMENSION
 * DIMENSIONS ARE TO INTERSECTION OF LINES
 ALL CALCULATIONS APPLY AT MAXIMUM MATERIAL CONDITION (MMC)

Δ 6 GROOVES
 Δ .110+.002 [2.79+0.05] WIDE
 TWIST: 10[254] R.H. OPTIONAL
 MIN. BORE & GROOVE
 AREA: .0882 SQ. IN. [56.903 mm²]

NOTICE: This drawing is subject to change.
 Current version is available at www.saami.org.

MAXIMUM CARTRIDGE / MINIMUM CHAMBER

338 WINCHESTER MAGNUM

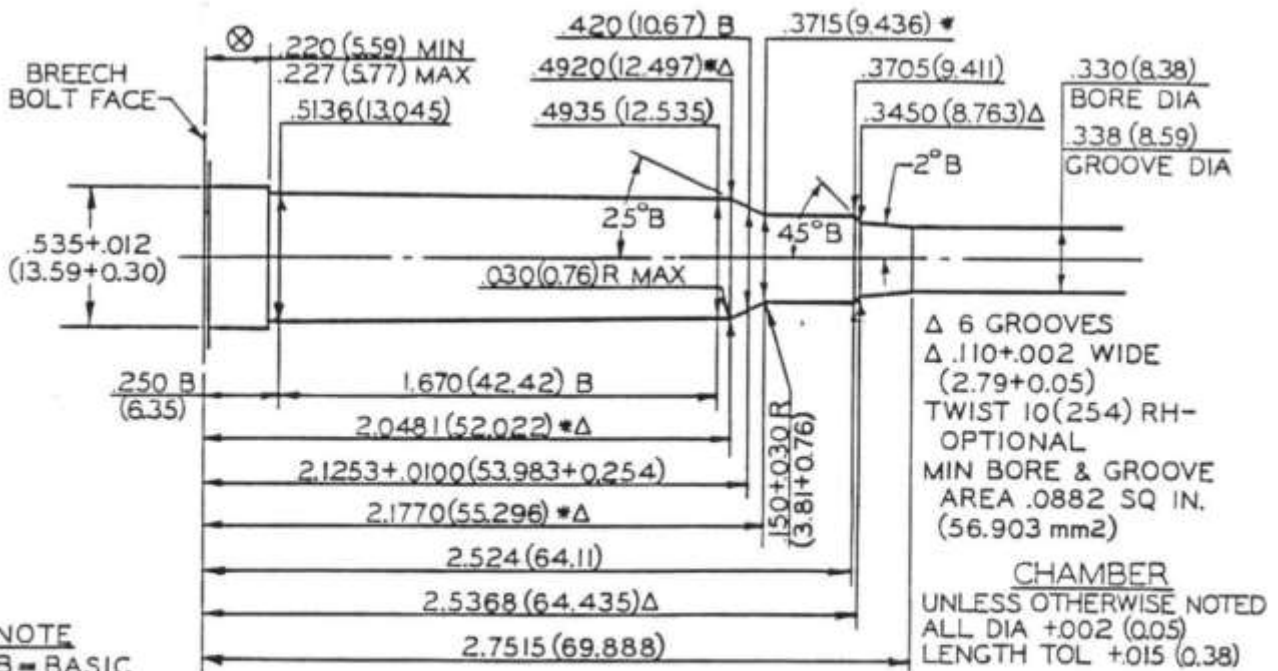
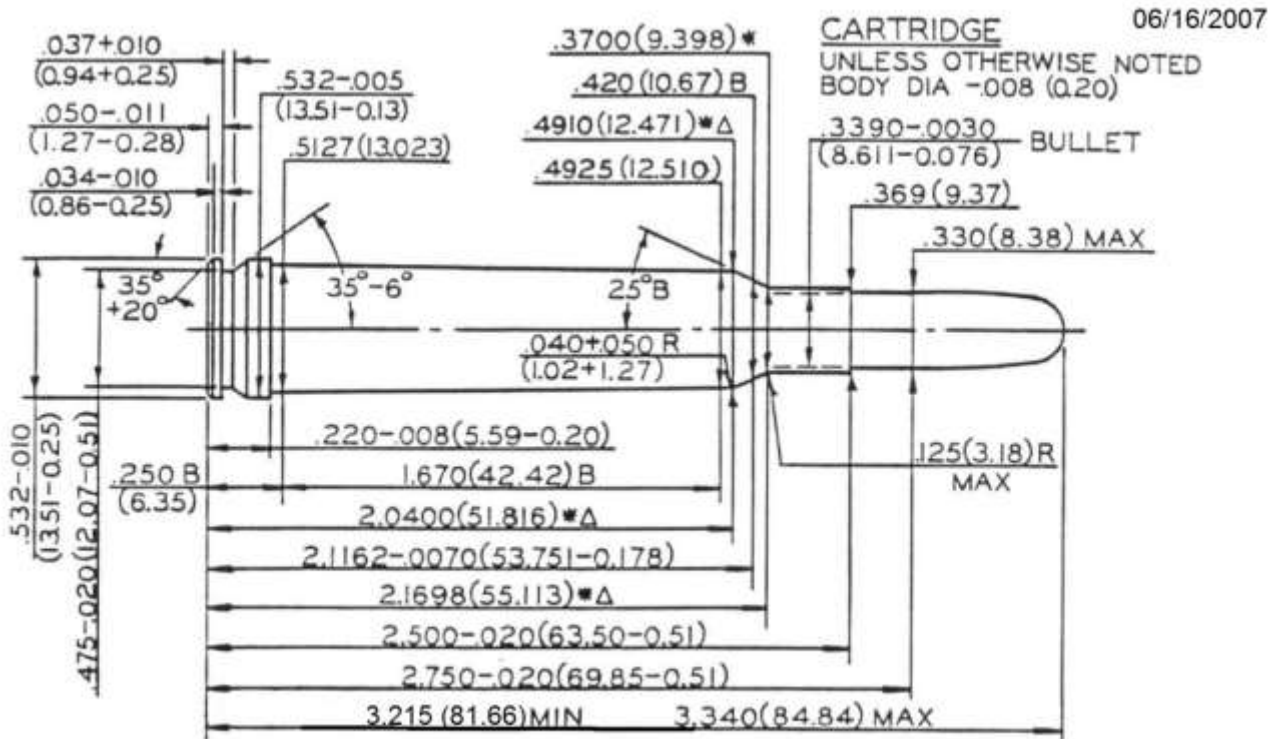

NOTE

- B = BASIC
- (XX.XX) = MILLIMETERS
- ⊗ = HEADSPACE DIMENSION
- * DIMENSIONS ARE TO INTERSECTION OF LINES Δ = REFERENCE DIMENSION
- ALL CALCULATIONS APPLY AT MAXIMUM MATERIAL CONDITION (MMC)

NOTICE: This drawing is subject to change.
 Current version is available at www.saami.org.

MAXIMUM CARTRIDGE / MINIMUM CHAMBER

340 WEATHERBY MAGNUM

01/2001

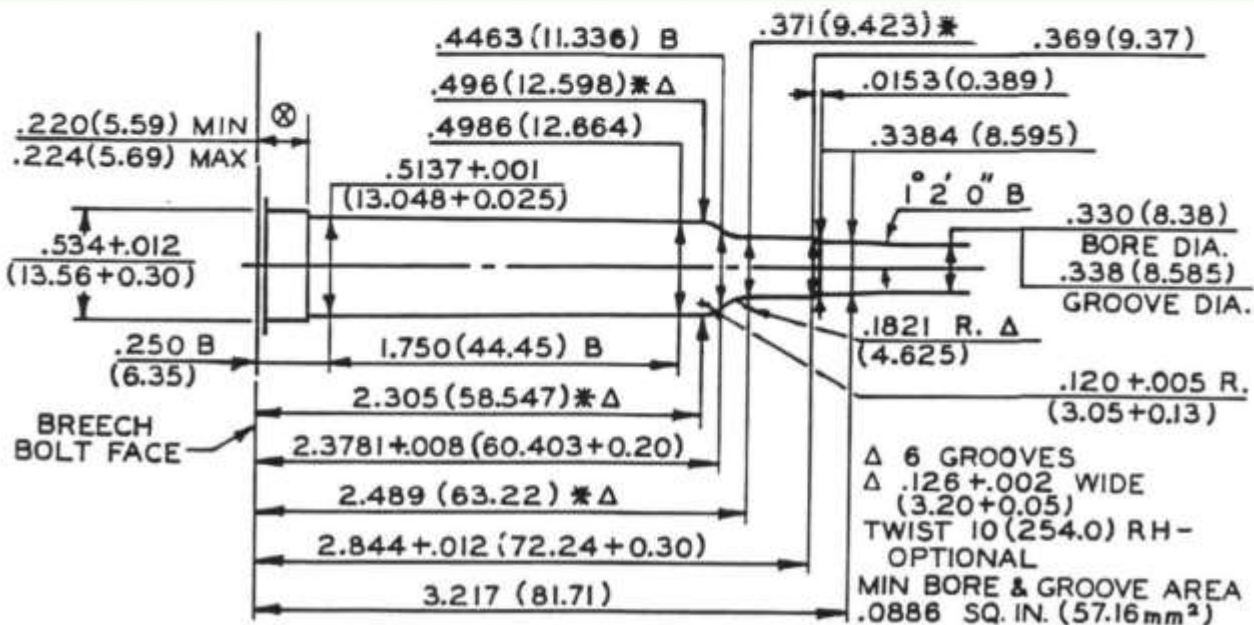
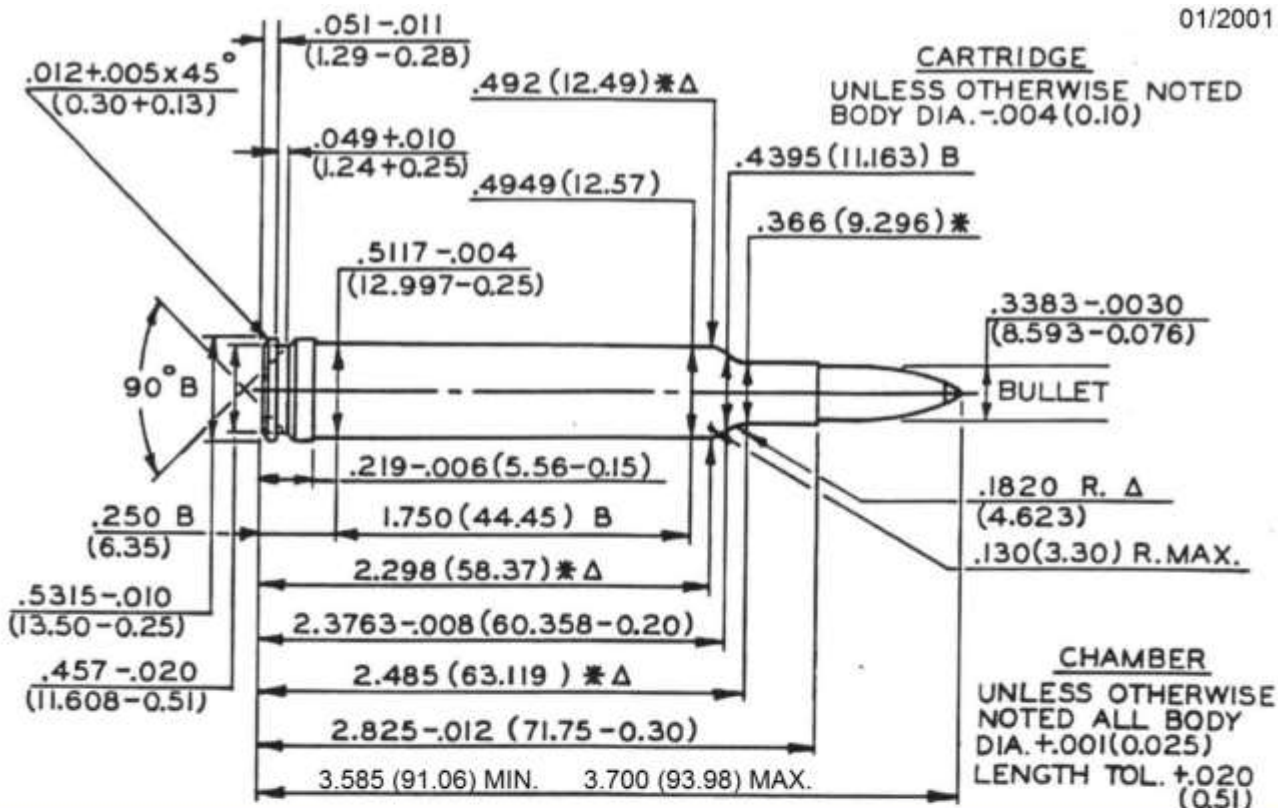

NOTE

- B=BASIC
- (XX.XX)=MILLIMETERS
- ⊗=HEADSPACE DIMENSION
- * DIMENSIONS ARE TO INTERSECTION OF LINES
- Δ REFERENCE DIMENSION
- ALL CALCULATIONS APPLY AT MAXIMUM MATERIAL CONDITION (MMC)

NOTICE: This drawing is subject to change.
 Current version is available at www.saami.org.

MAXIMUM CARTRIDGE / MINIMUM CHAMBER

348 WINCHESTER

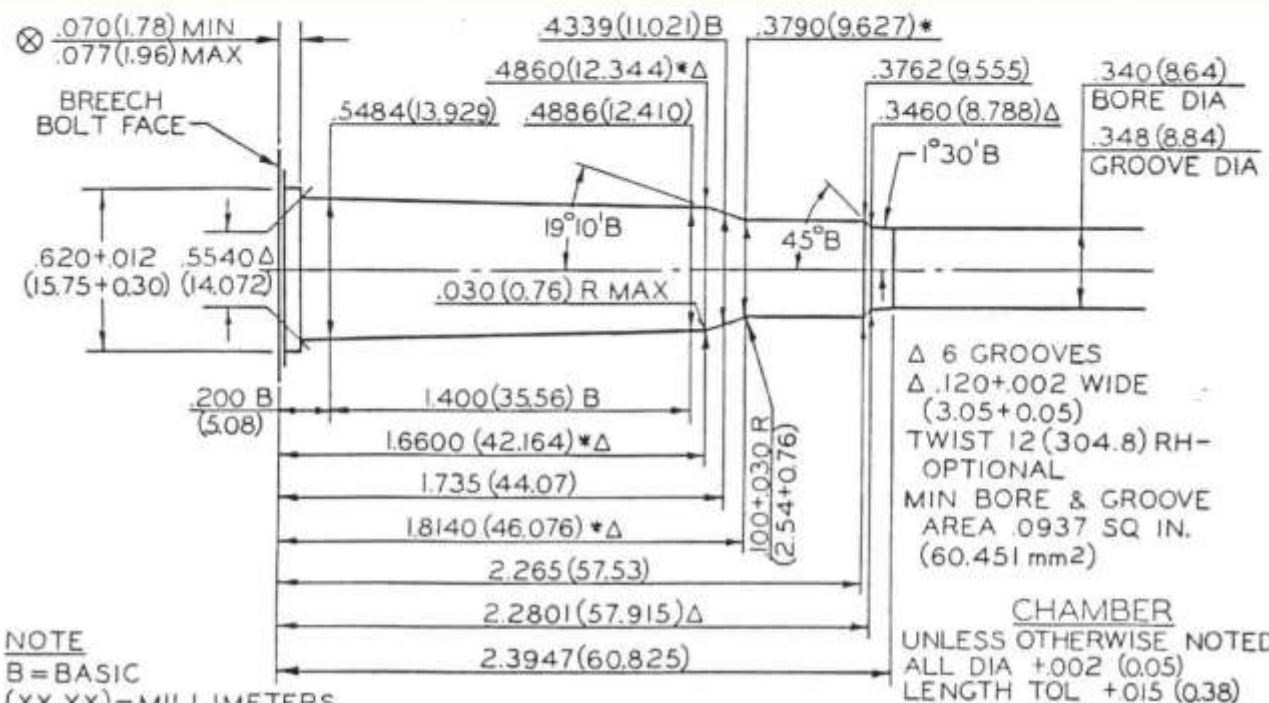
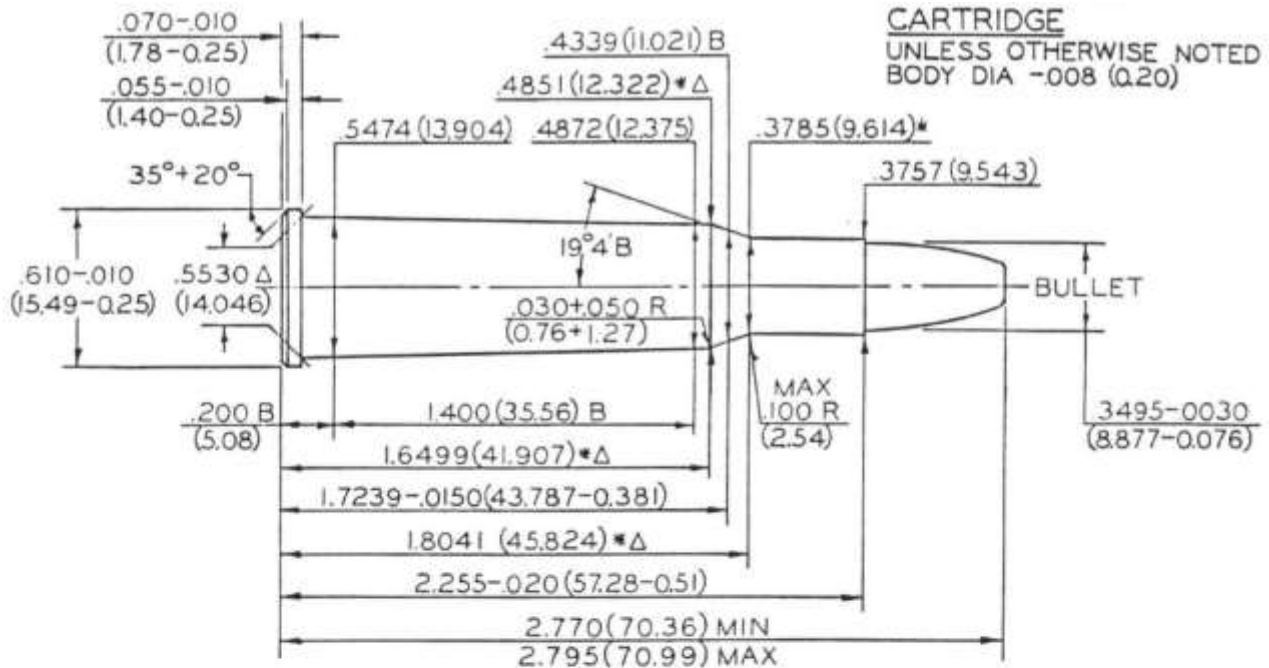

NOTICE: This drawing is subject to change.
 Current version is available at www.saami.org.

MAXIMUM CARTRIDGE / MINIMUM CHAMBER

35 NOSLER

CARTRIDGE

UNLESS OTHERWISE NOTED
 BODY DIA. -.008 (0.20)

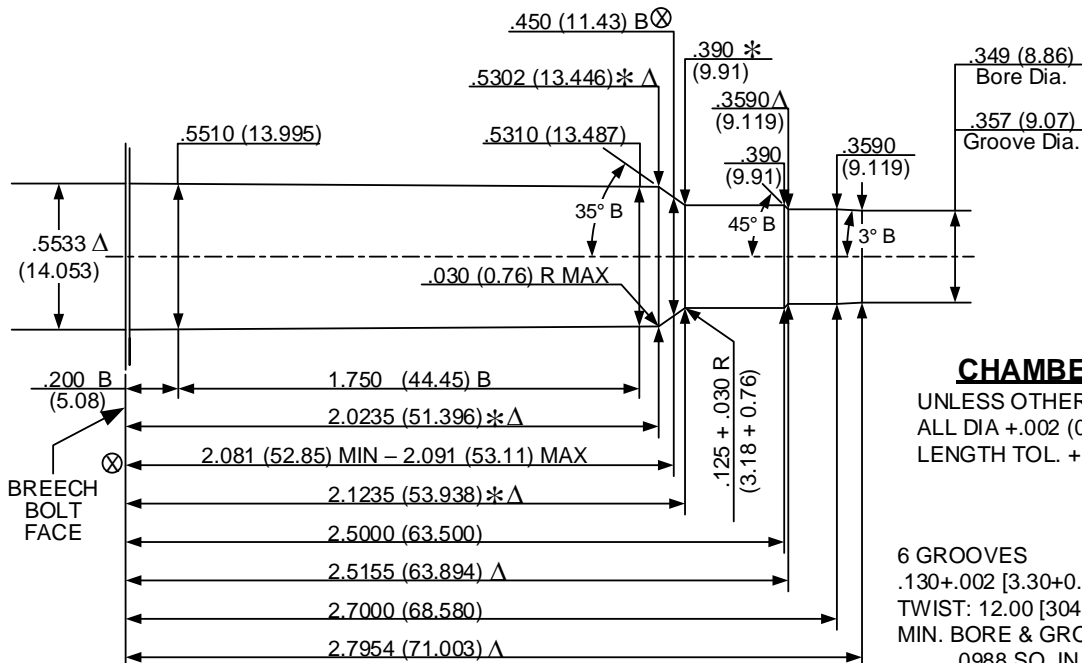
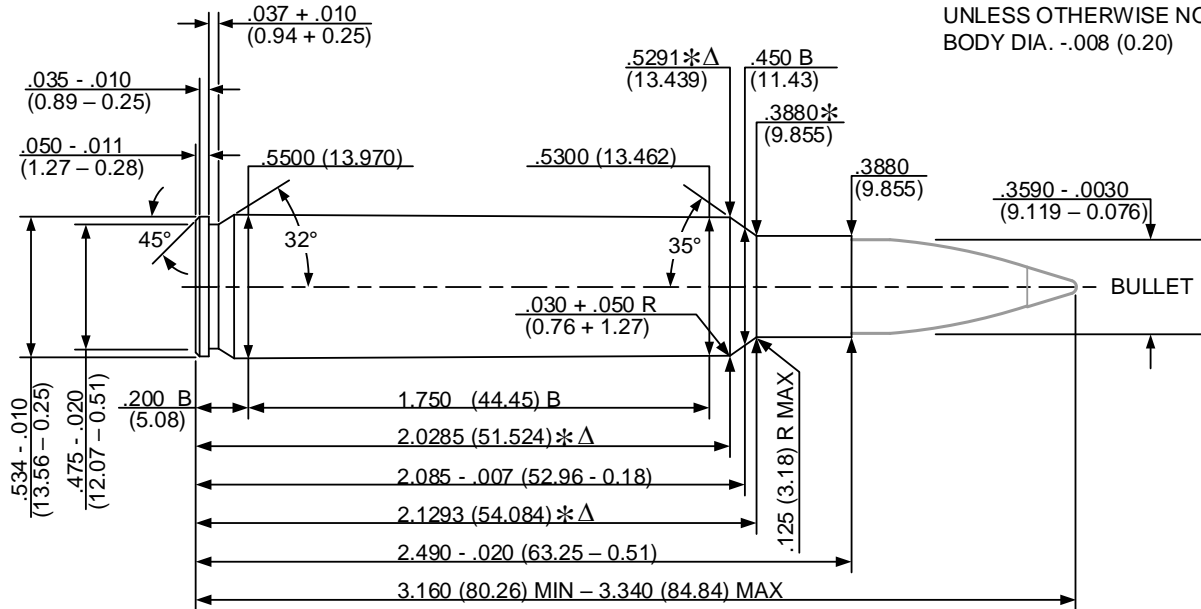

CHAMBER

UNLESS OTHERWISE NOTED
 ALL DIA +.002 (0.05)
 LENGTH TOL. +.015 (0.38)

6 GROOVES
 .130+.002 [3.30+0.05] WIDE
 TWIST: 12.00 [304.8] R.H. OPTIONAL
 MIN. BORE & GROOVE AREA:
 .0988 SQ. IN. [63.741 MM²]

NOTE:
 B = BASIC
 (XX.XX) = MILLIMETERS
 ⊗ = HEAD SPACE DIMENSION
 Δ = REFERENCE DIMENSION
 * = DIMENSIONS ARE TO INTERSECTION OF LINES
 ALL CALCULATIONS APPLY AT MAXIMUM MATERIAL CONDITION (MMC)

NOTICE: This drawing is subject to change.
 Current version is available at www.saami.org.

MAXIMUM CARTRIDGE / MINIMUM CHAMBER

35 REMINGTON

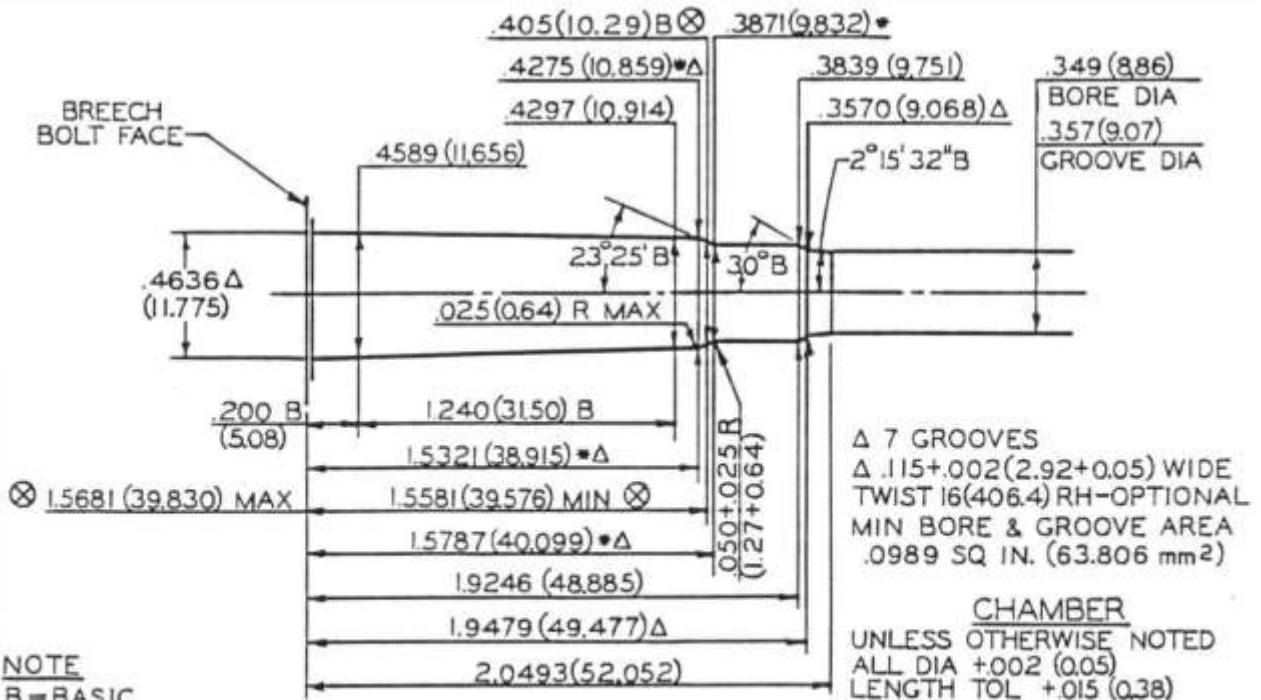
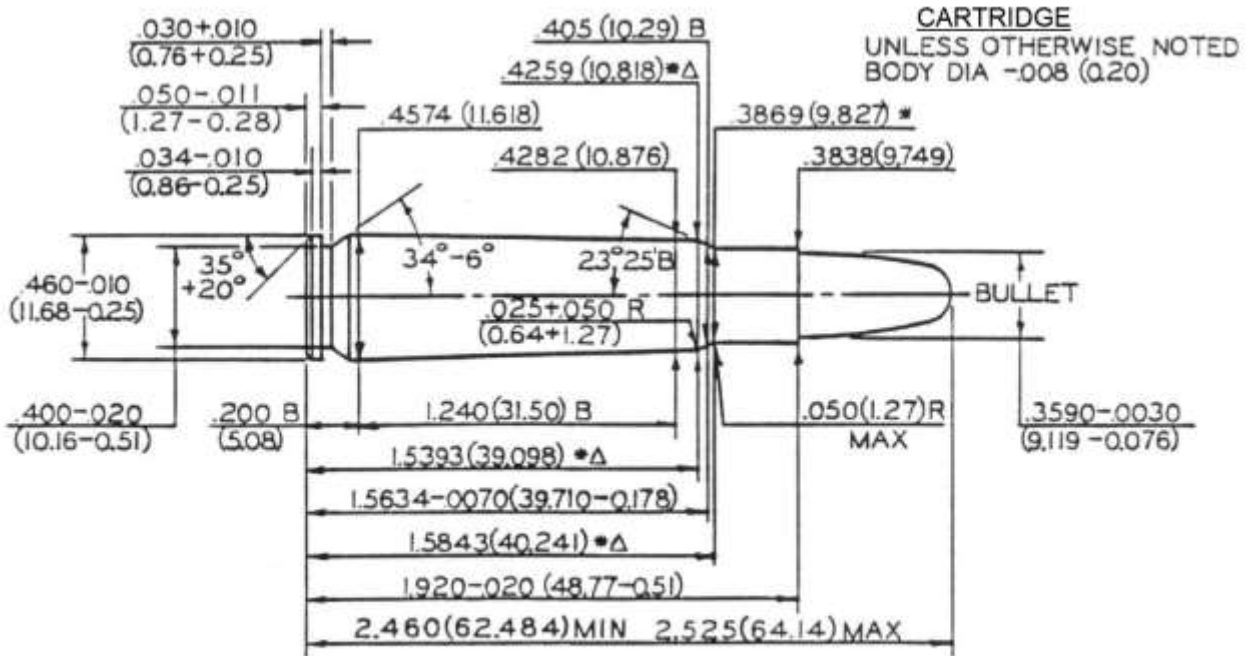

NOTE
 B=BASIC
 (XX.XX)=MILLIMETERS
 ⊗ =HEADSPACE DIMENSION
 * DIMENSIONS ARE TO INTERSECTION OF LINES Δ=REFERENCE DIMENSION
 ALL CALCULATIONS APPLY AT MAXIMUM MATERIAL CONDITION (MMC)

NOTICE: This drawing is subject to change.
 Current version is available at www.saami.org.

MAXIMUM CARTRIDGE / MINIMUM CHAMBER

35 WHELEN

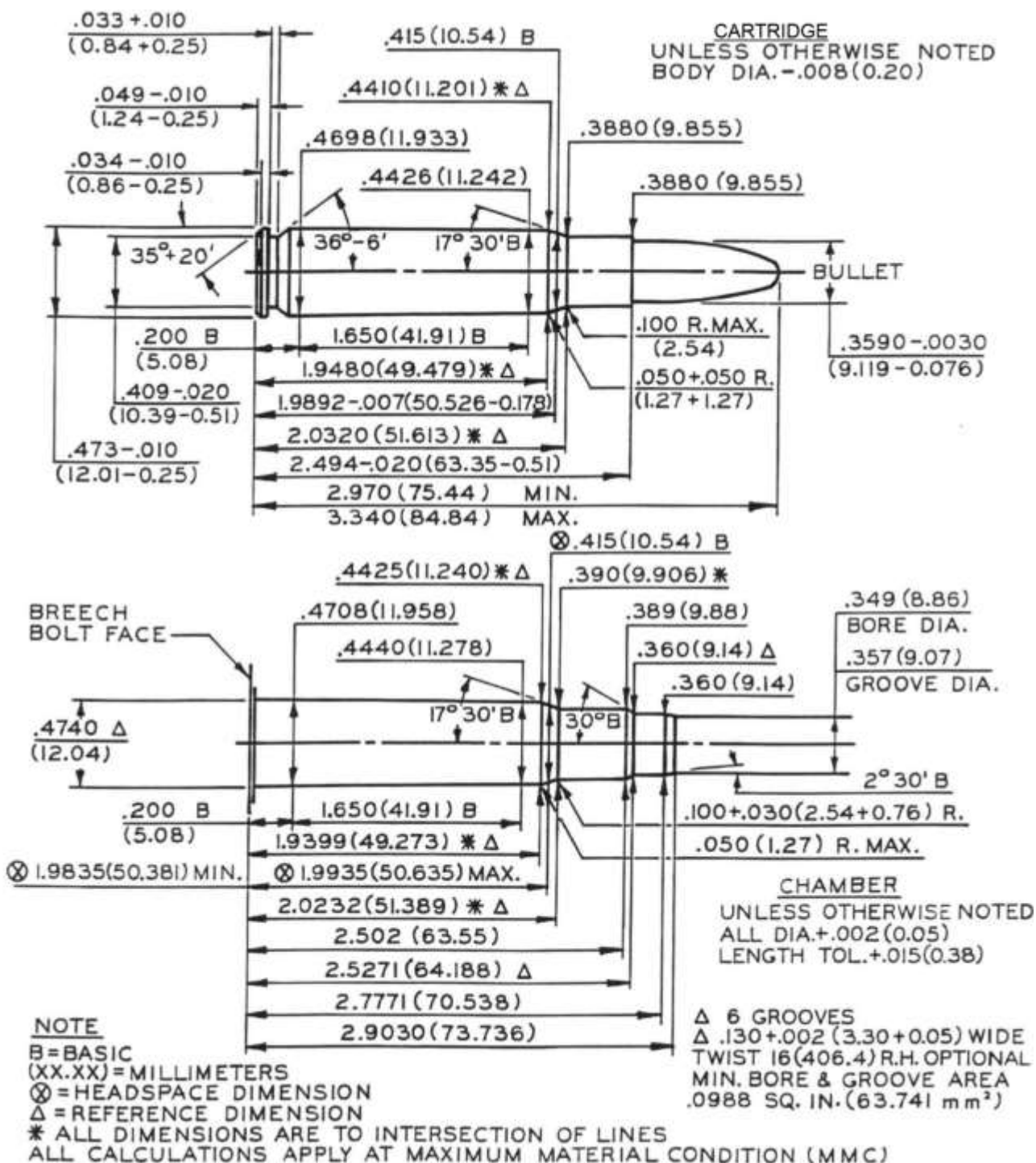

NOTICE: This drawing is subject to change.
 Current version is available at www.saami.org.

MAXIMUM CARTRIDGE / MINIMUM CHAMBER

350 REMINGTON MAGNUM

ISSUED 04/21/1980

REVISED 11/25/05

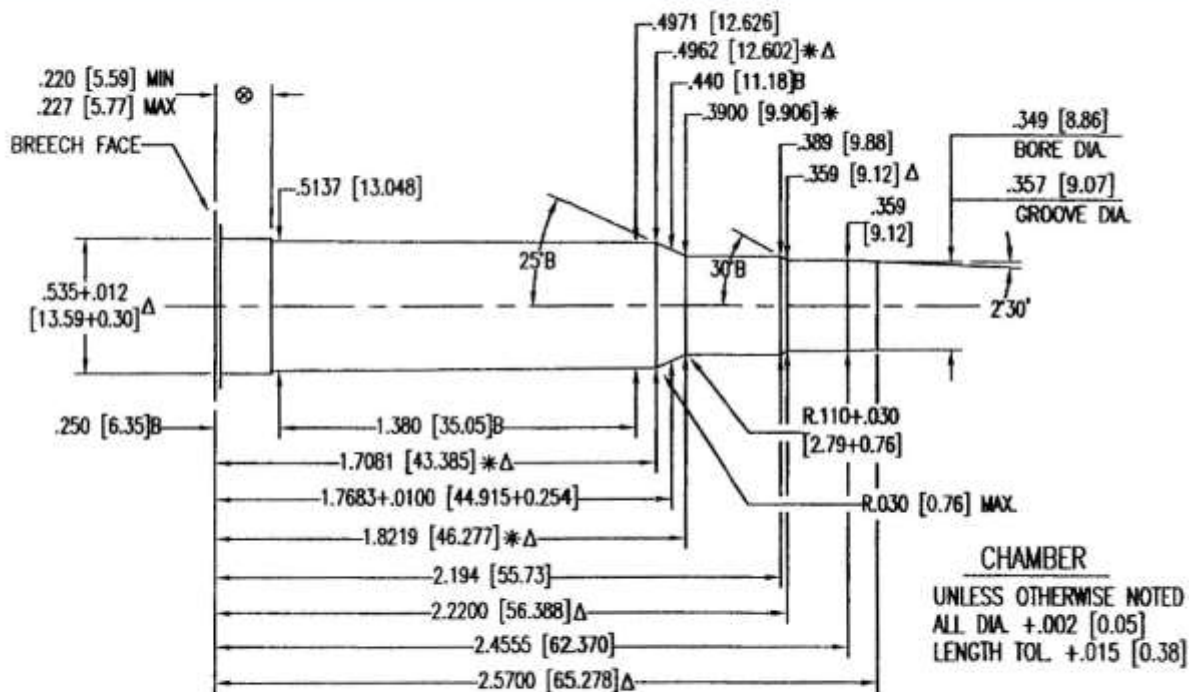
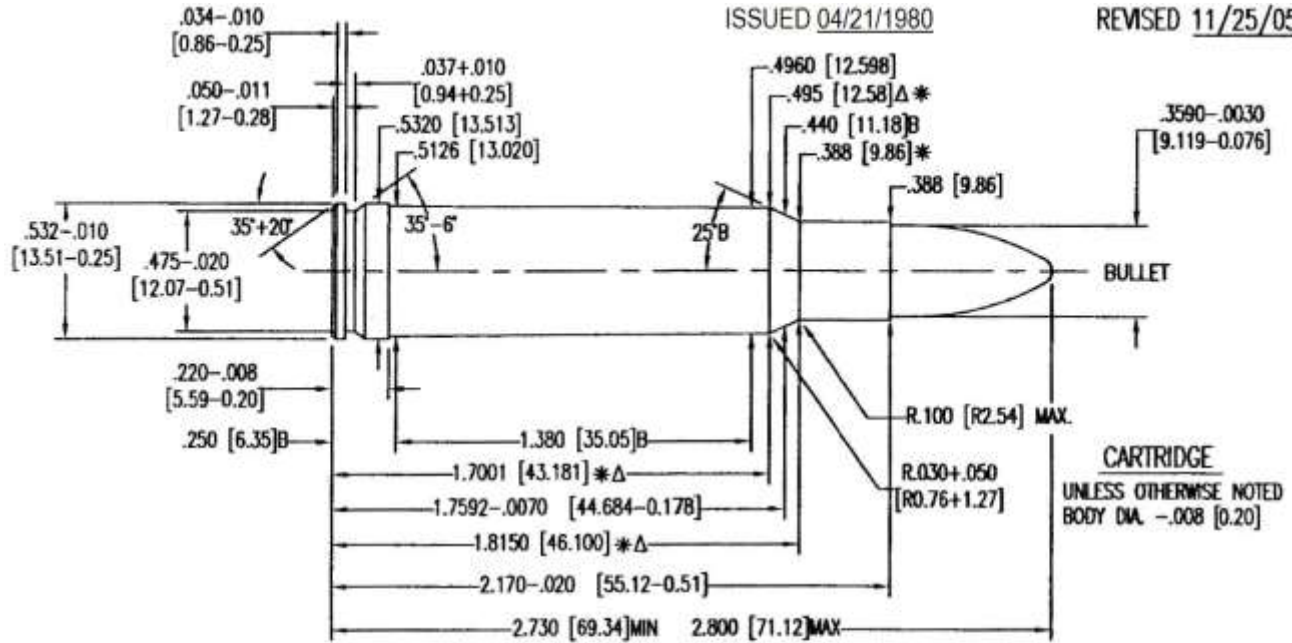

NOTE:
 B=BASIC [XX.XX]=MILLIMETERS
 ⊗ = HEADSPACE DIMENSION Δ = REFERENCE DIMENSION
 * DIMENSIONS ARE TO INTERSECTION OF LINES
 ALL CALCULATIONS APPLY AT MAXIMUM MATERIAL CONDITION (MMC)

Δ 6 GROOVES
 Δ.130+.002 [3.30+0.05] WIDE
 TWIST: 16 [406.4] R.H. OPTIONAL
 MIN. BORE & GROOVE
 AREA: .0988 SQ. IN. [63.741 mm²]

NOTICE: This drawing is subject to change.
 Current version is available at www.saami.org.

MAXIMUM CARTRIDGE / MINIMUM CHAMBER

356 WINCHESTER

11/08/1983

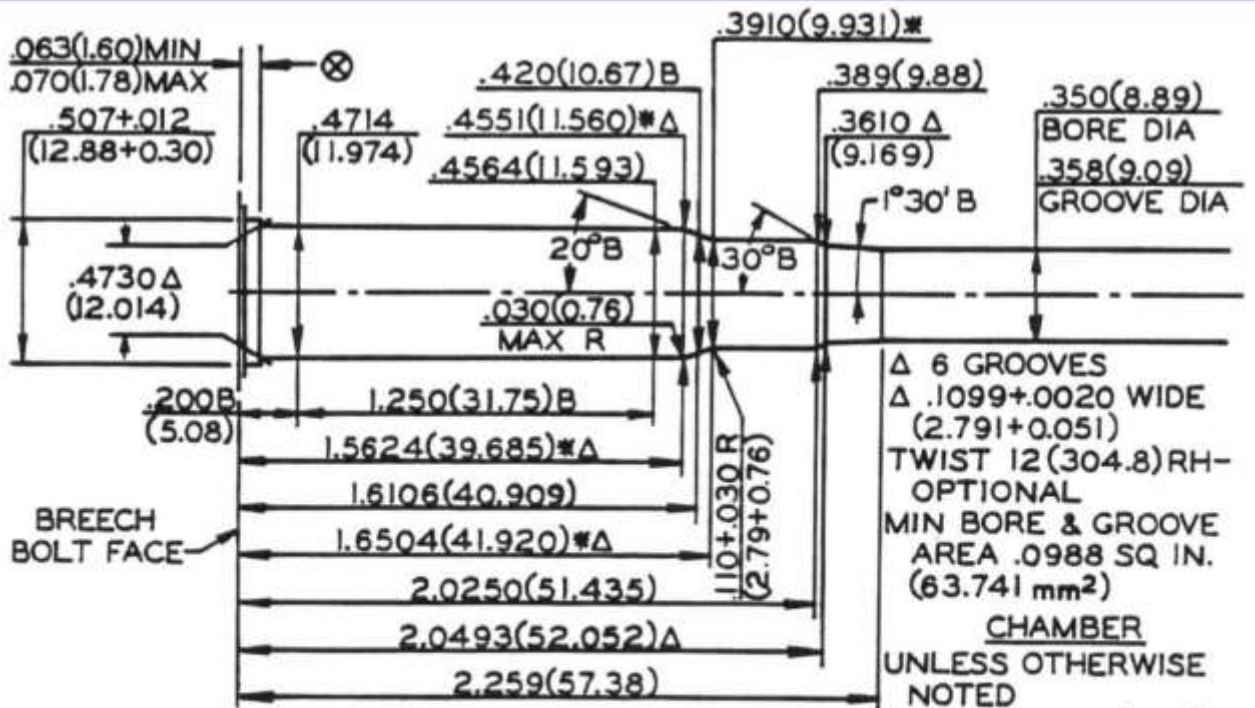
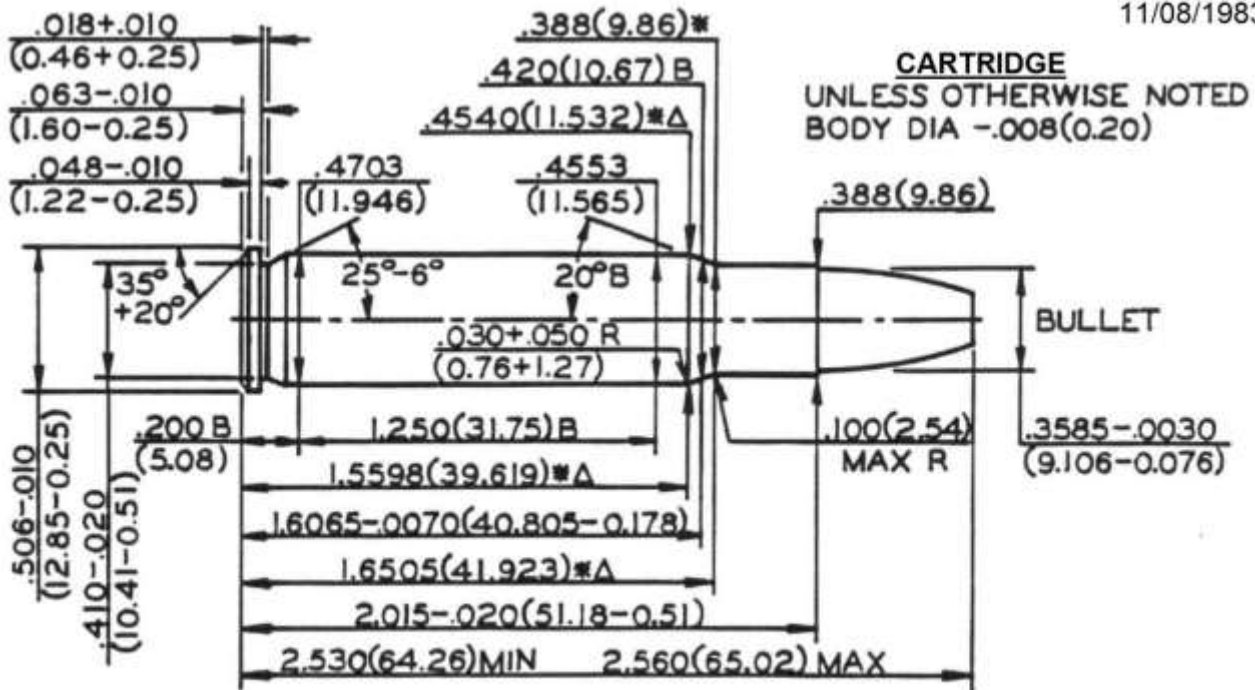

NOTE
 B=BASIC Δ=REFERENCE DIMENSION ⊗=HEADSPACE DIMENSION
 * DIMENSIONS ARE TO INTERSECTION OF LINES (XX.XX)=MILLIMETERS
 ALL CALCULATIONS APPLY AT MAXIMUM MATERIAL CONDITION (MMC)

NOTICE: This drawing is subject to change.
 Current version is available at www.saami.org.

MAXIMUM CARTRIDGE / MINIMUM CHAMBER

358 WINCHESTER

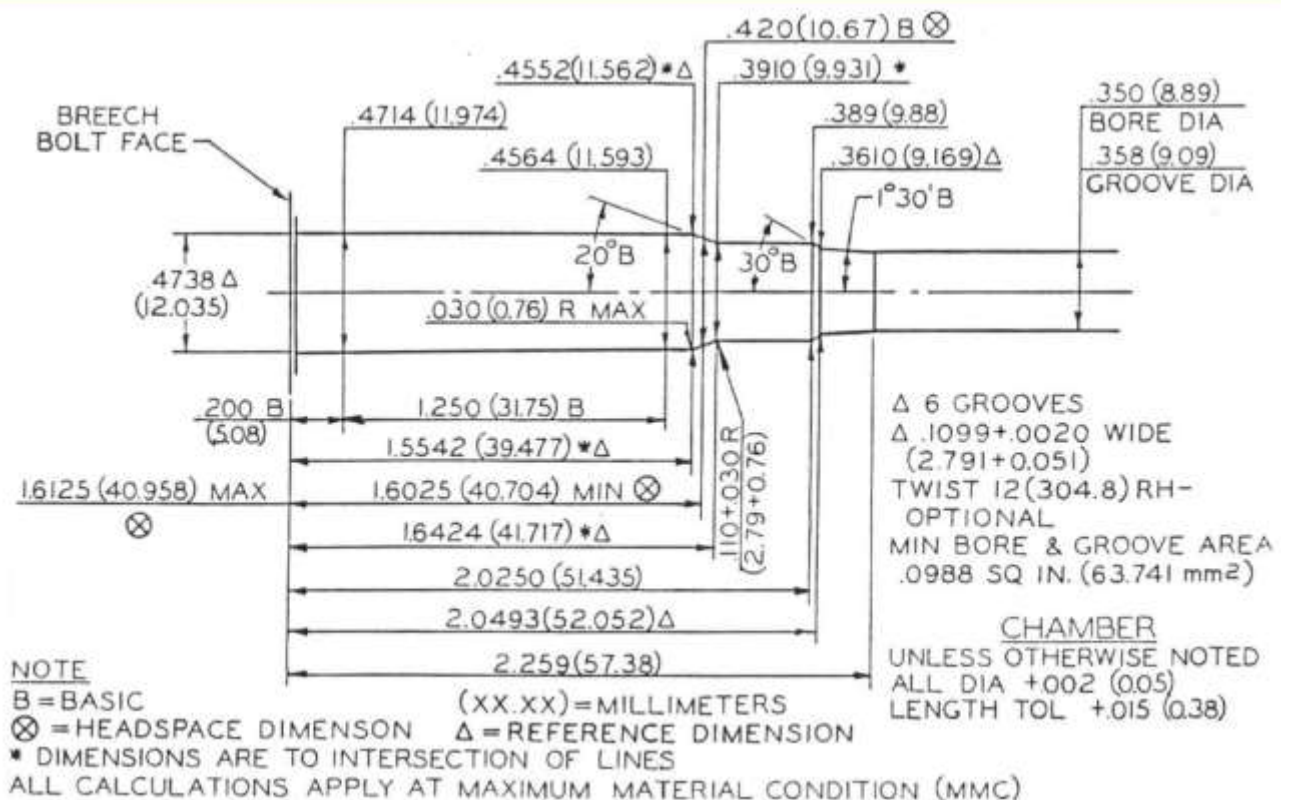
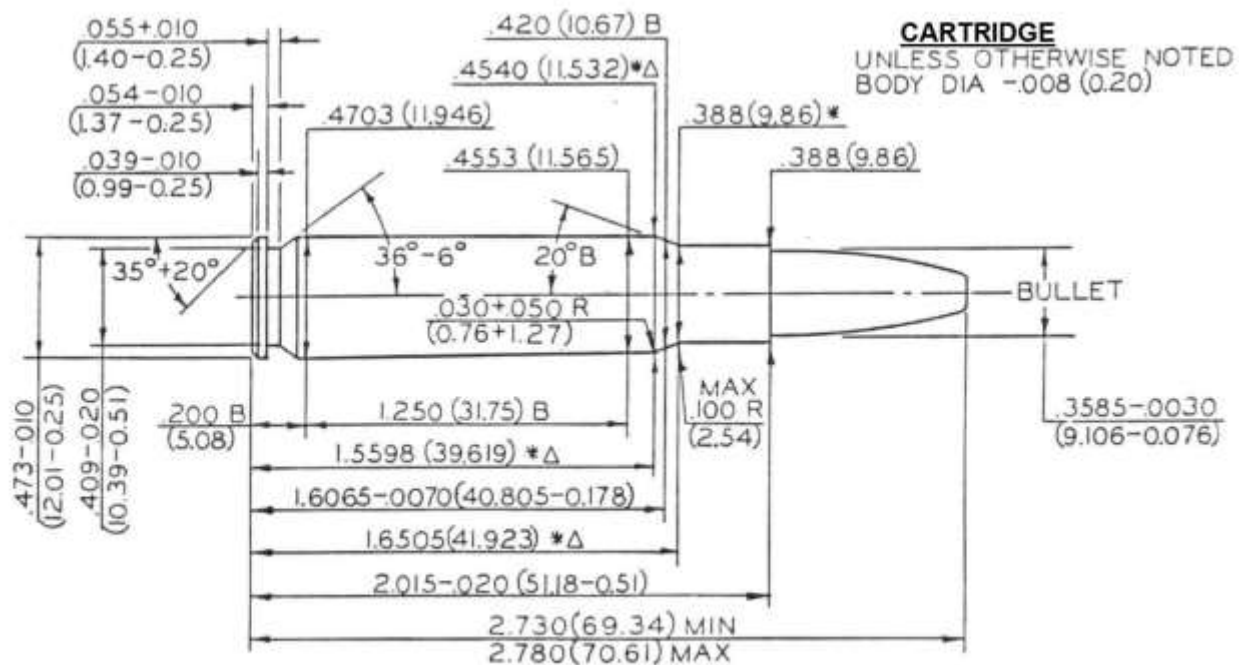

NOTICE: This drawing is subject to change.
 Current version is available at www.saami.org.

MAXIMUM CARTRIDGE / MINIMUM CHAMBER

370 SAKO MAGNUM

HIGHLIGHTED DIMENSIONS HAVE NO CORRESPONDING C.I.P. ANALOG.

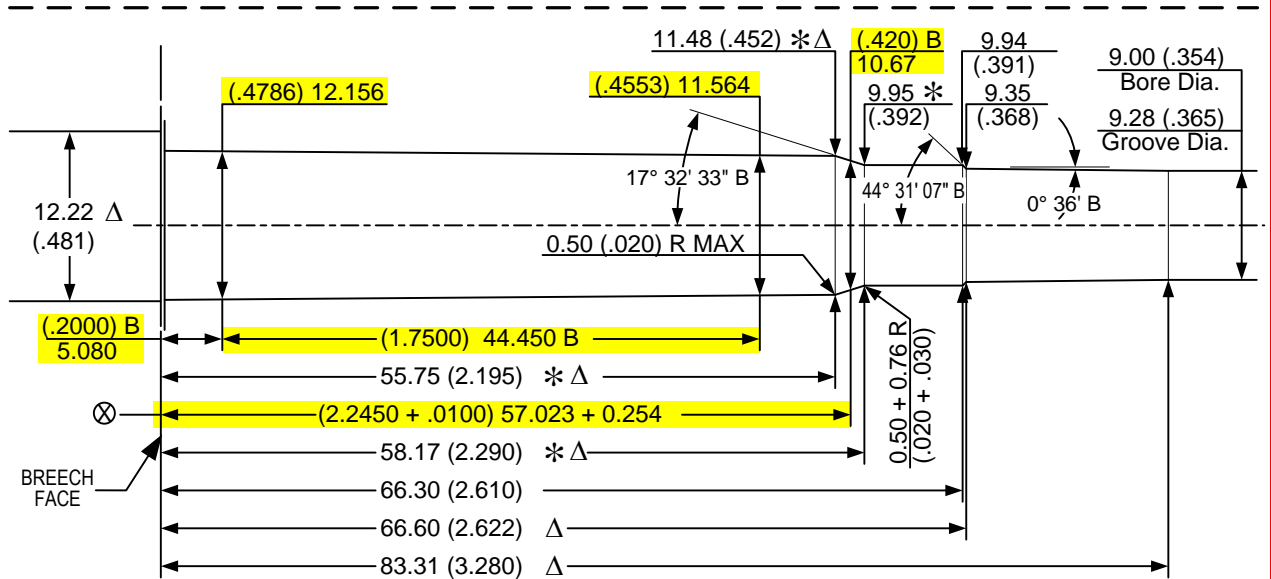
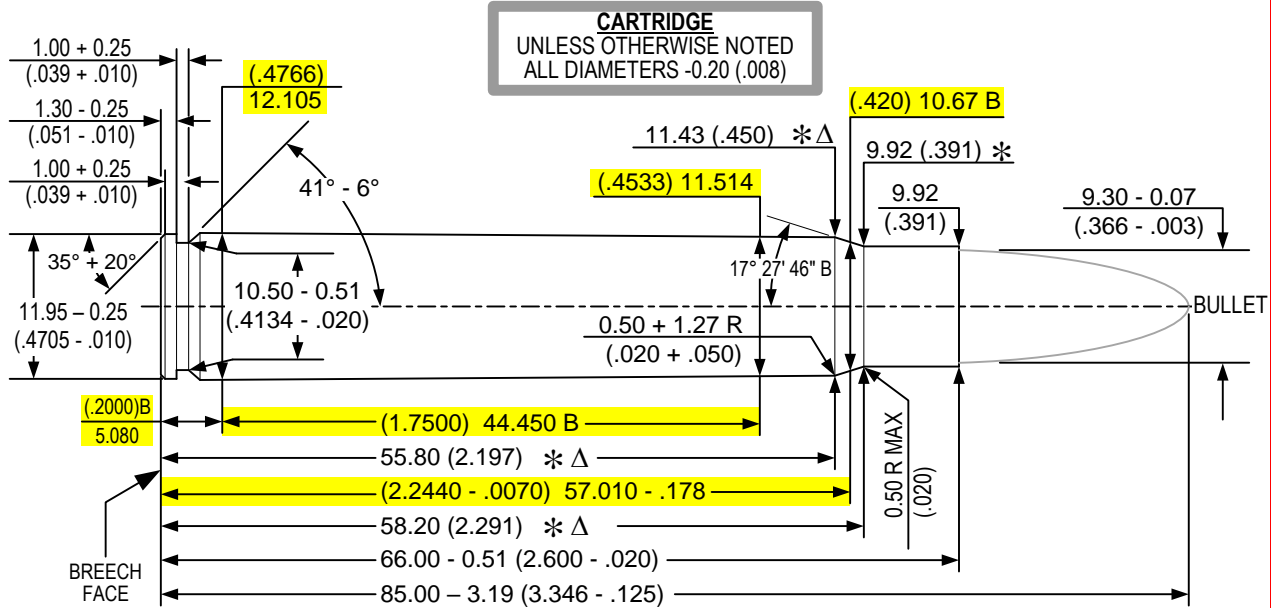

OPTIONAL:
 6 GROOVES TWIST: 360.0 (14.17) RH
 3.14 + 0.05 (.124 + .002) WIDE MIN. BORE & GROOVE AREA: 66.310 mm² (.1028 in²)

CHAMBER
 UNLESS OTHERWISE NOTED
 ALL DIA. +0.05 (.002)
 LENGTH TOL +0.38 (.015)

NOTE:
 B = BASIC Δ = REFERENCE DIMENSION ⊗ = HEADSPACE DIMENSION
 * DIMENSIONS ARE TO INTERSECTIONS OF LINES (XX.XXXX) = INCHES
 ALL CALCULATIONS APPLY AT MAXIMUM MATERIAL CONDITION (MMC)

METRIC (9.3 x 66 SAKO)

NOTICE: This drawing is subject to change.
 Current version is available at www.saami.org.

MAXIMUM CARTRIDGE / MINIMUM CHAMBER

375 H&H MAGNUM

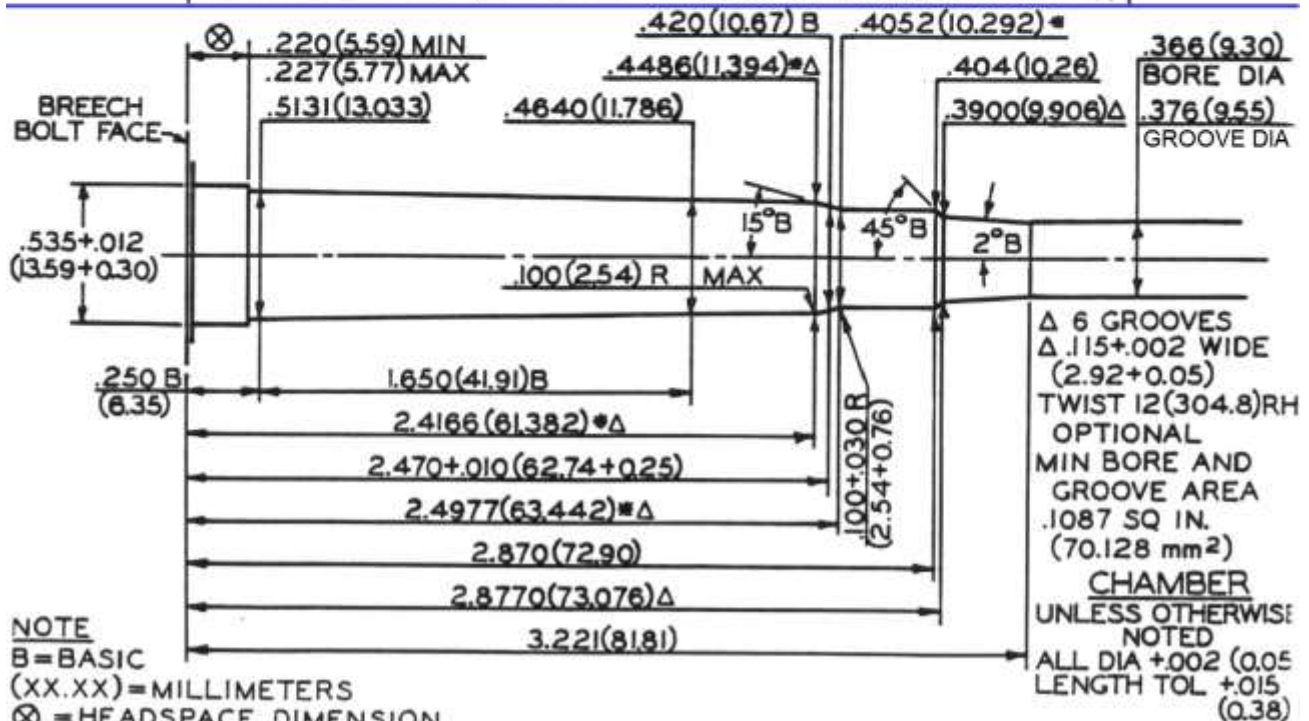
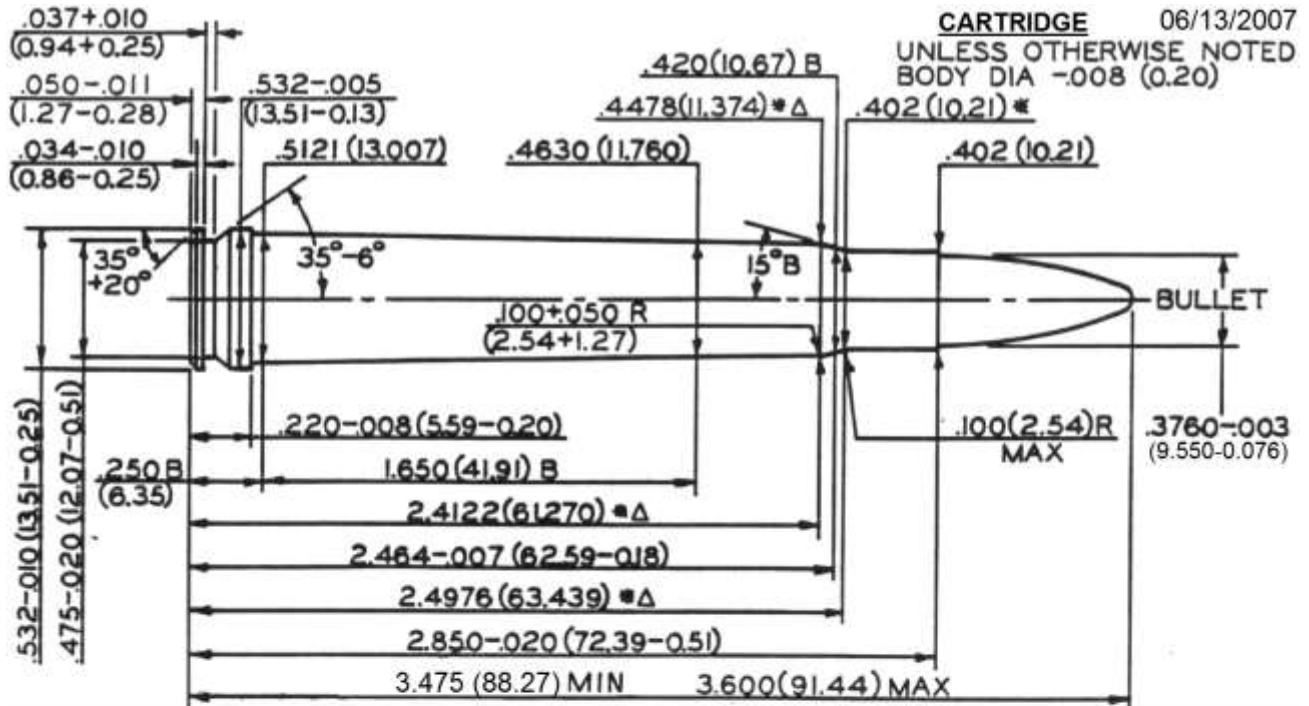

NOTE
 B=BASIC
 (XX.XX)=MILLIMETERS
 ⊗ =HEADSPACE DIMENSION
 * DIMENSIONS ARE TO INTERSECTION OF LINES Δ=REFERENCE DIMENSION
 ALL CALCULATIONS APPLY AT MAXIMUM MATERIAL CONDITION (MMC)

Δ 6 GROOVES
 Δ .115+0.002 WIDE
 (2.92+0.05)
 TWIST 12(304.8)RH
 OPTIONAL
 MIN BORE AND
 GROOVE AREA
 .1087 SQ IN.
 (70.128 mm²)
CHAMBER
 UNLESS OTHERWISE
 NOTED
 ALL DIA +.002 (0.05)
 LENGTH TOL +.015
 (0.38)

NOTICE: This drawing is subject to change.
 Current version is available at www.saami.org.

MAXIMUM CARTRIDGE / MINIMUM CHAMBER
375 REMINGTON ULTRA MAGNUM

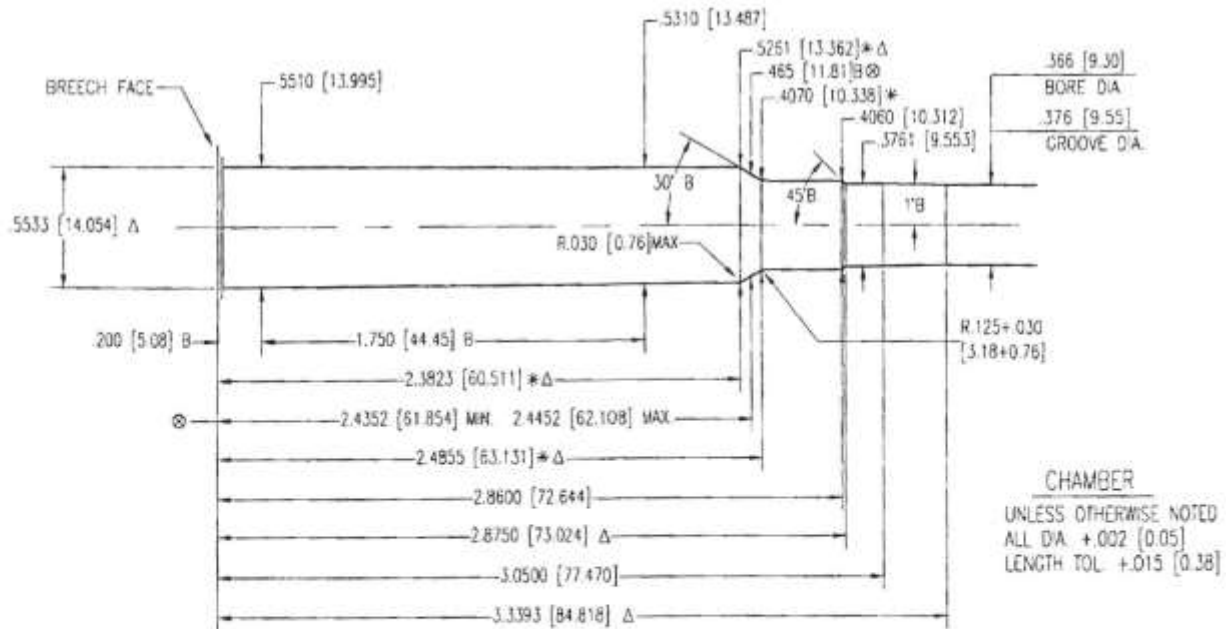
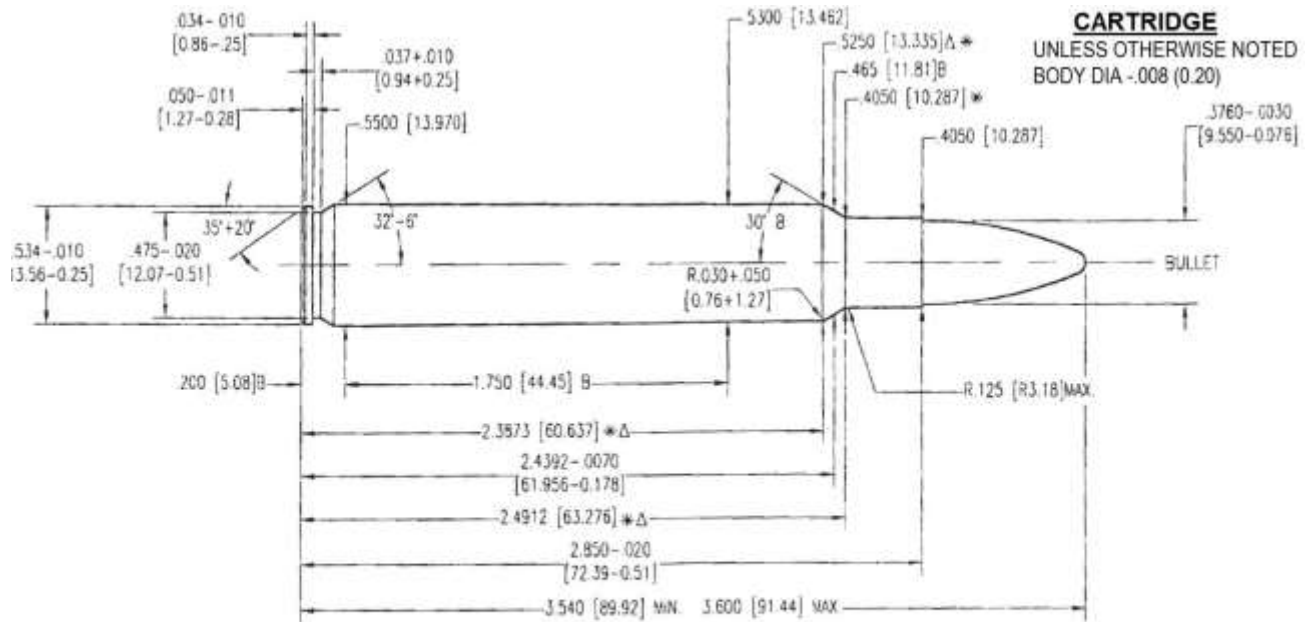

NOTE:
 B=BASIC
 [XX.XX]=MILLIMETERS
 ⊕ = HEADSPACE DIMENSION
 Δ = REFERENCE DIMENSION
 * DIMENSIONS ARE TO INTERSECTION OF LINES
 ALL CALCULATIONS APPLY AT MAXIMUM MATERIAL CONDITION (MMC)

Δ 6 GROOVES
 Δ .115+.002 [2.92+0.05] WIDE
 TWIST: 12 [304.8] R.H. OPTIONAL
 MIN. BORE & GROOVE
 AREA: .1087 SQ. IN. [70.128 mm²]

NOTICE: This drawing is subject to change.
 Current version is available at www.saami.org.

MAXIMUM CARTRIDGE / MINIMUM CHAMBER

375 RUGER

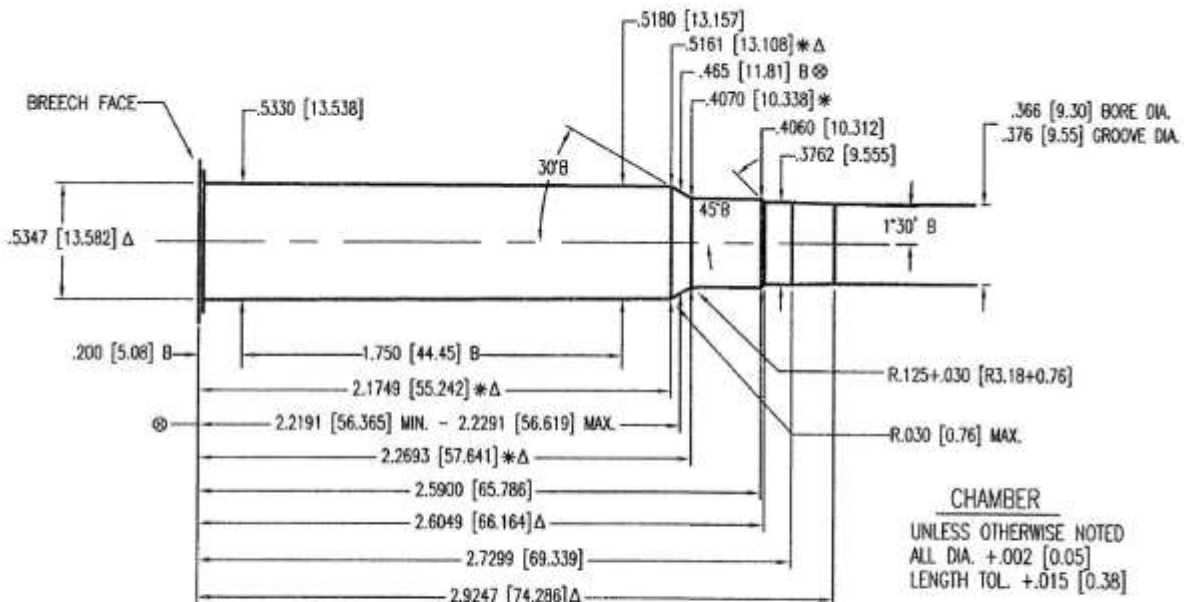
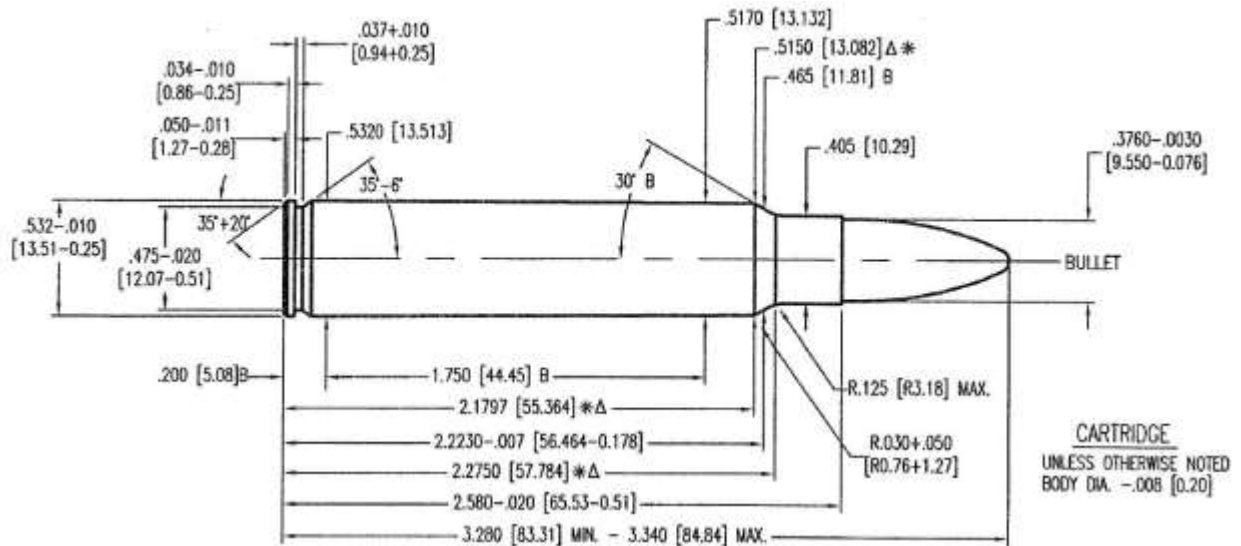

NOTE:
 B=BASIC
 [XX.XX]=MILLIMETERS
 ⊕ = HEADSPACE DIMENSION
 Δ = REFERENCE DIMENSION
 * DIMENSIONS ARE TO INTERSECTION OF LINES
 ALL CALCULATIONS APPLY AT MAXIMUM MATERIAL CONDITION (MMC)

Δ 6 GROOVES
 Δ .115+.002 [2.92+0.05] WIDE
 TWIST: 12 [304.8] R.H. OPTIONAL
 MIN. BORE & GROOVE
 AREA: .1087 SQ. IN. [70.128 mm²]

NOTICE: This drawing is subject to change.
 Current version is available at www.saami.org.

MAXIMUM CARTRIDGE / MINIMUM CHAMBER

376 STEYR

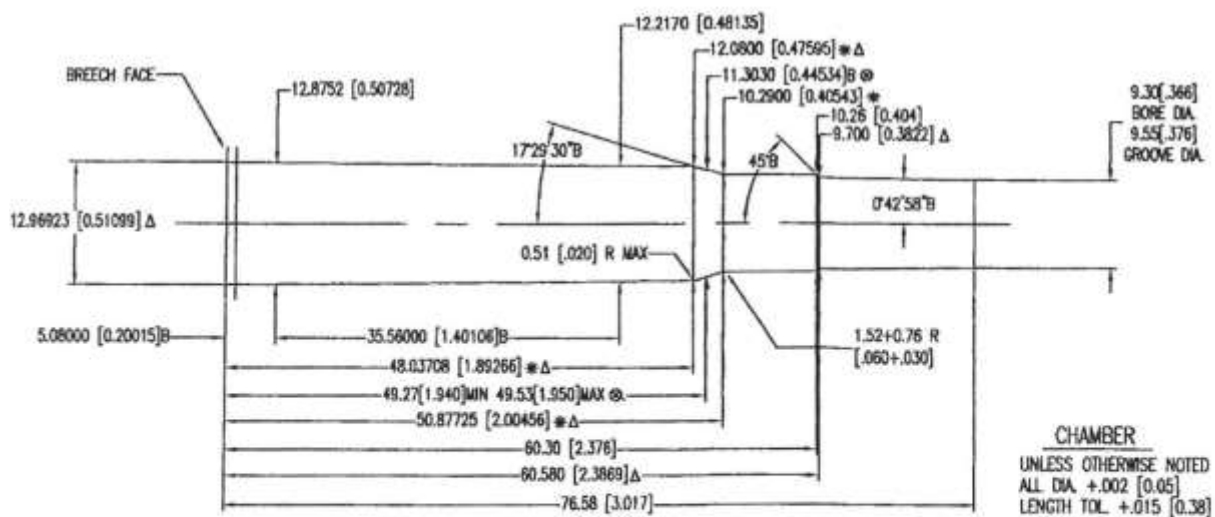
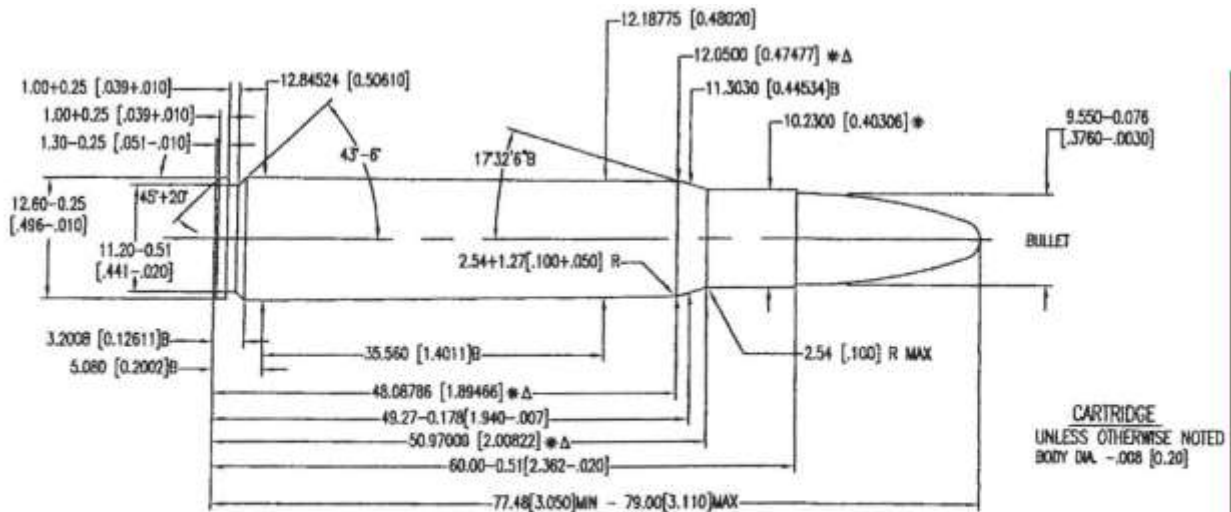

NOTE:
 B=BASIC
 [XX.XX] = INCHES
 @ = HEADSPACE DIMENSION
 Δ = REFERENCE DIMENSION
 * DIMENSIONS ARE TO INTERSECTION OF LINES
 ALL CALCULATIONS APPLY AT MAXIMUM MATERIAL CONDITION (MMC)

Δ 6 GROOVES
 Δ 2.92+0.05 [.115+.002] WIDE
 TWIST: 304.B [12] R.H. OPTIONAL
 MIN. BORE & GROOVE
 AREA: 70.128 mm² [.1087 SQ. IN.]

METRIC ORIGIN

METRIC ORIGIN

METRIC ORIGIN

METRIC ORIGIN

NOTICE: This drawing is subject to change.
 Current version is available at www.saami.org.

MAXIMUM CARTRIDGE / MINIMUM CHAMBER

38-40 WINCHESTER

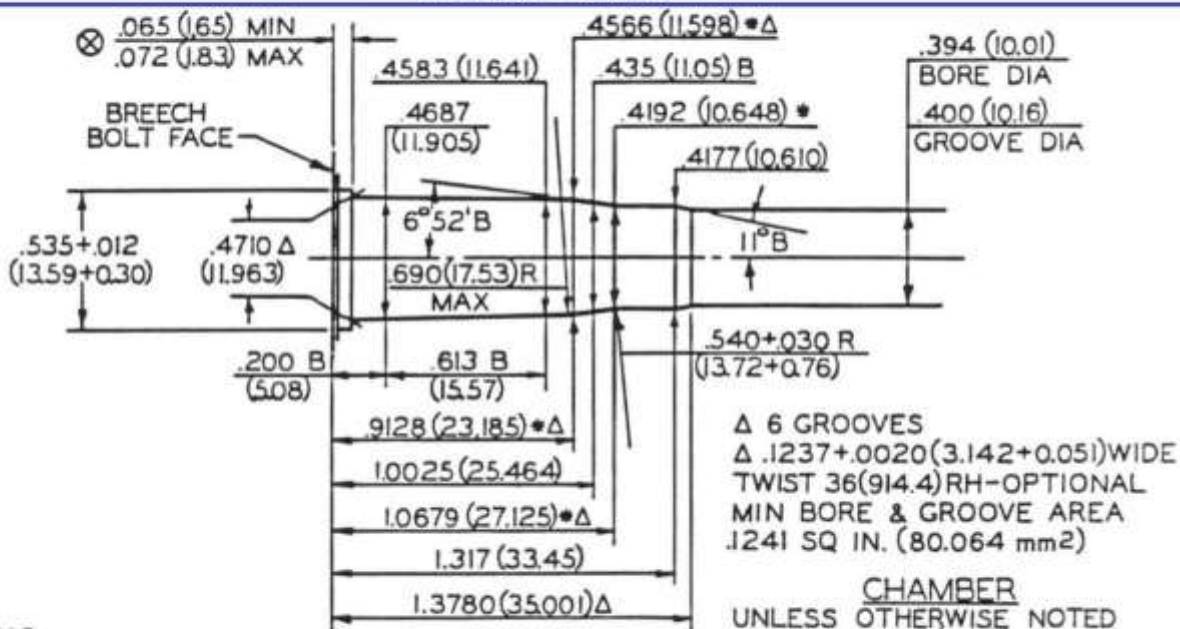
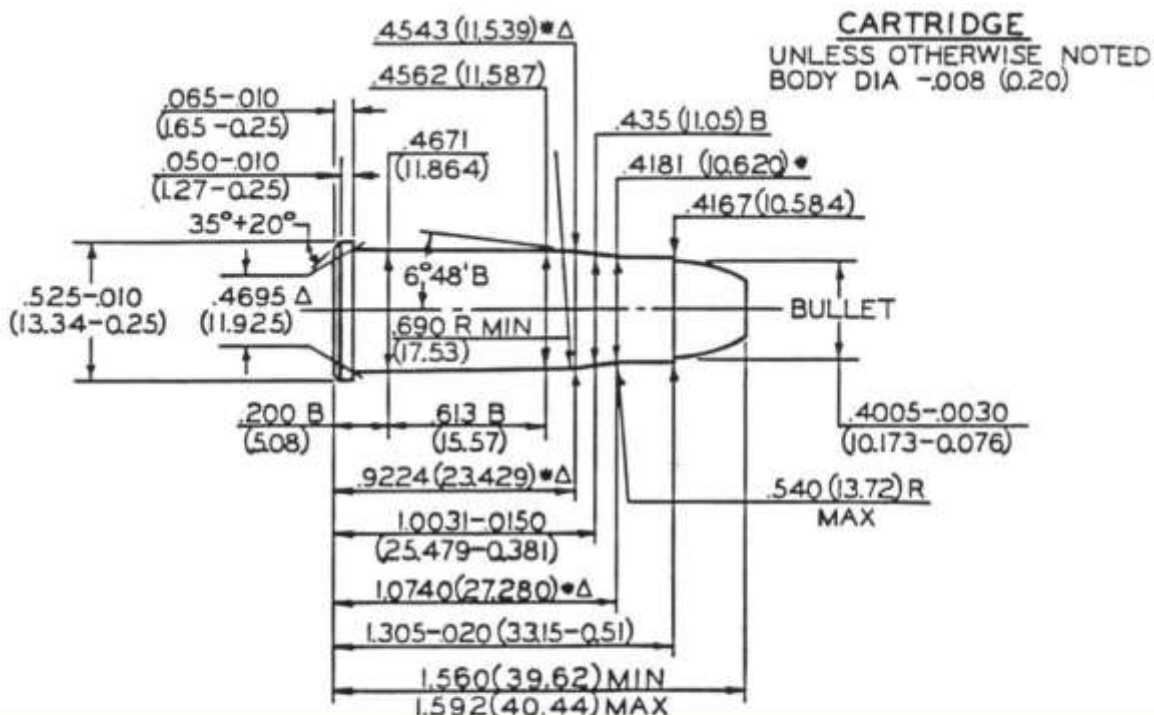

NOTE
 B = BASIC
 (XX.XX) = MILLIMETERS
 ⊗ = HEADSPACE DIMENSION
 Δ = REFERENCE DIMENSION
 * DIMENSIONS ARE TO INTERSECTION OF LINES
 ALL CALCULATIONS APPLY AT MAXIMUM MATERIAL CONDITION (MMC)

NOTICE: This drawing is subject to change.
 Current version is available at www.saami.org.

MAXIMUM CARTRIDGE / MINIMUM CHAMBER

38-55 WINCHESTER

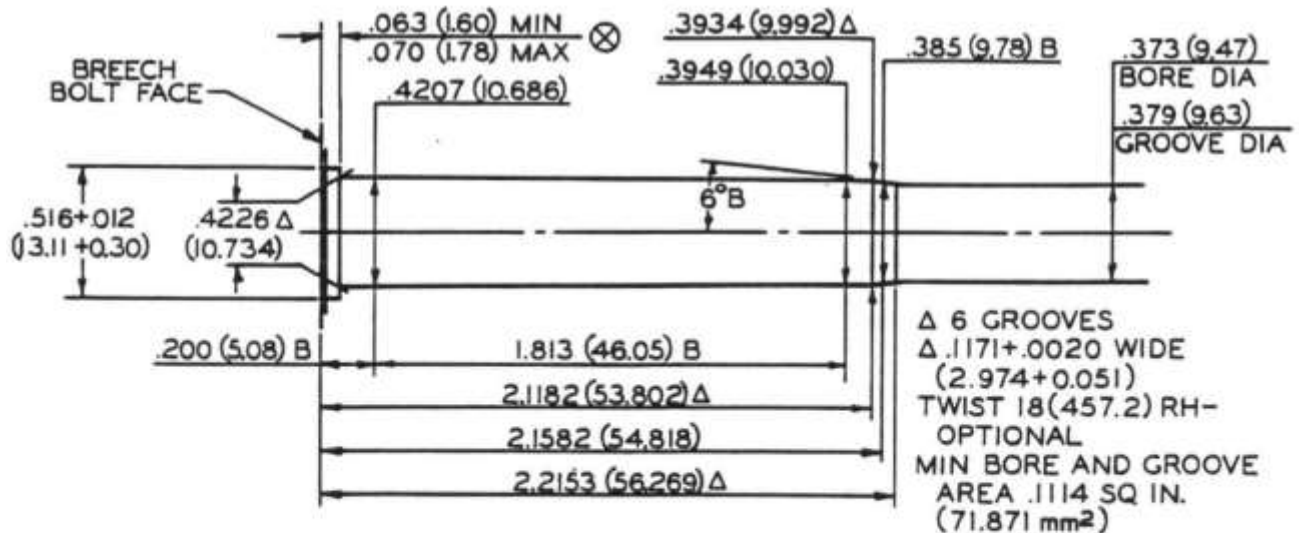
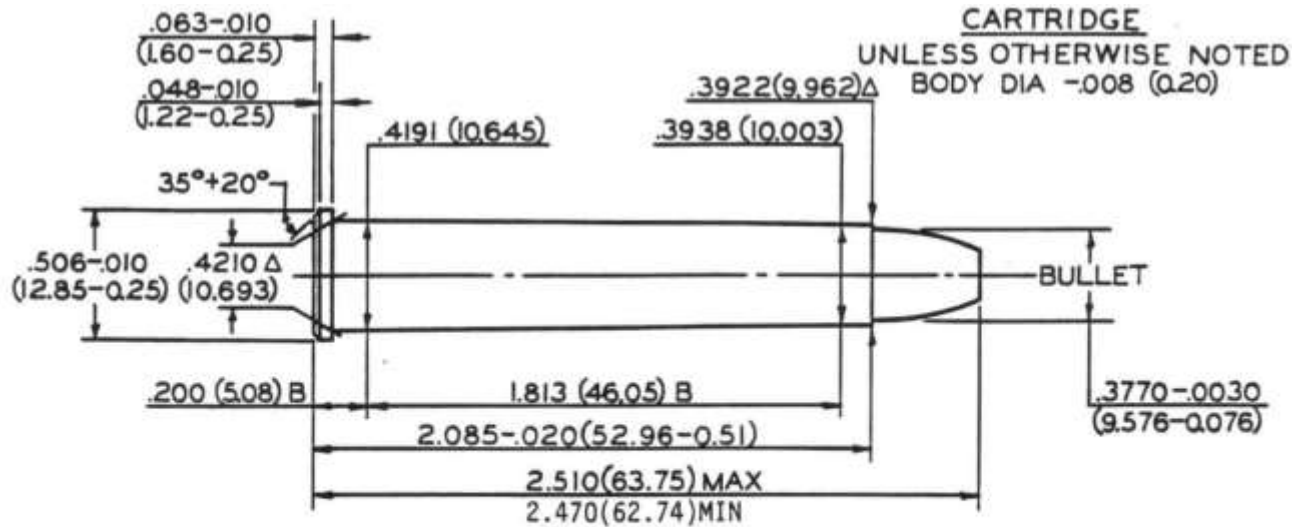

NOTE

B = BASIC

(XX.XX) = MILLIMETERS

⊗ = HEADSPACE DIMENSION

* DIMENSIONS ARE TO INTERSECTION OF LINES

Δ = REFERENCE DIMENSION

ALL CALCULATIONS APPLY AT MAXIMUM MATERIAL CONDITION (MMC)

NOTICE: This drawing is subject to change.
 Current version is available at www.saami.org.

MAXIMUM CARTRIDGE / MINIMUM CHAMBER

416 REMINGTON MAGNUM

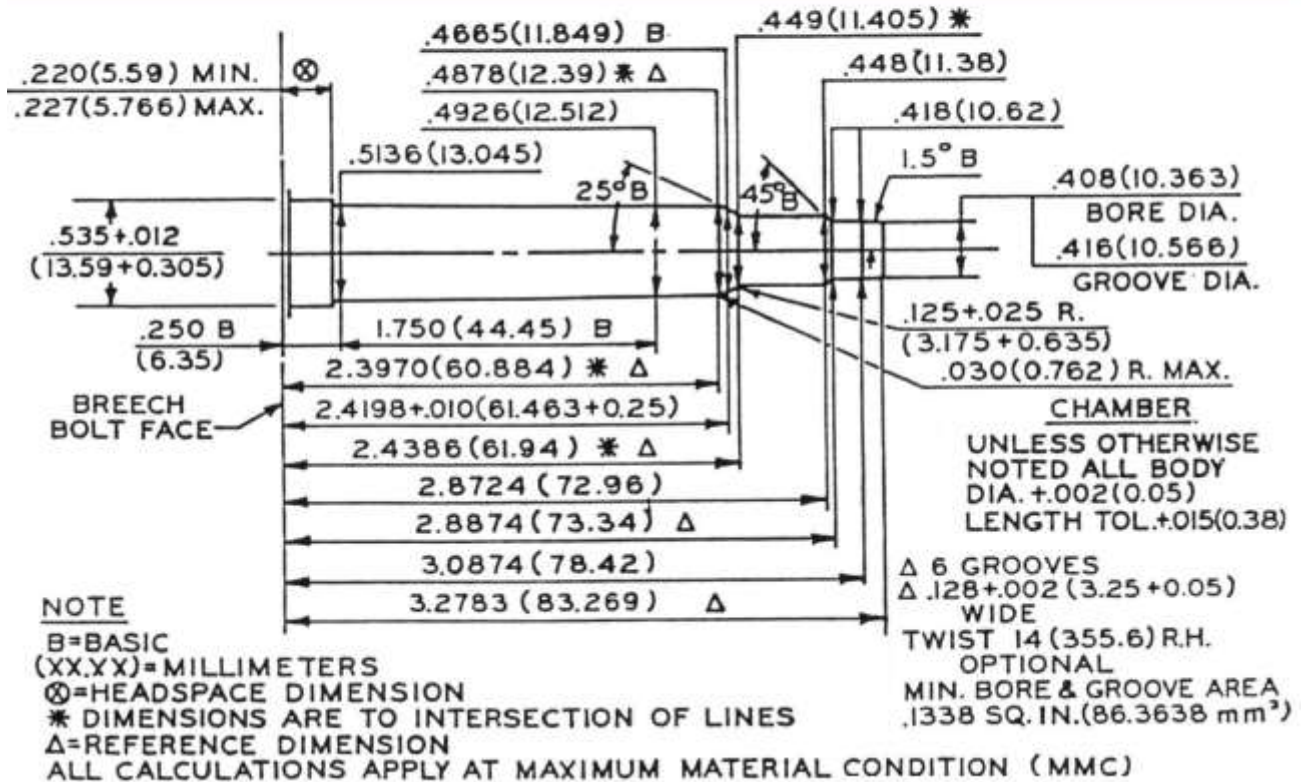
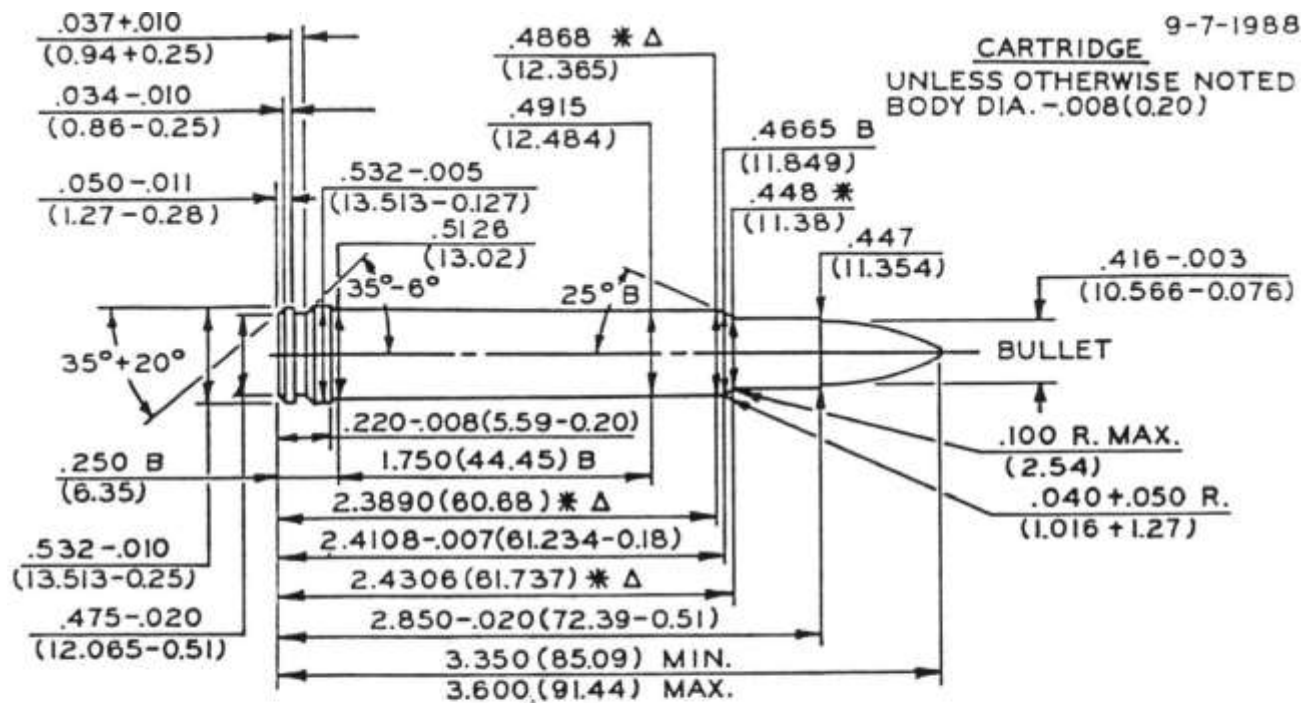

NOTICE: This drawing is subject to change.
 Current version is available at www.saami.org.

MAXIMUM CARTRIDGE / MINIMUM CHAMBER

416 RIGBY

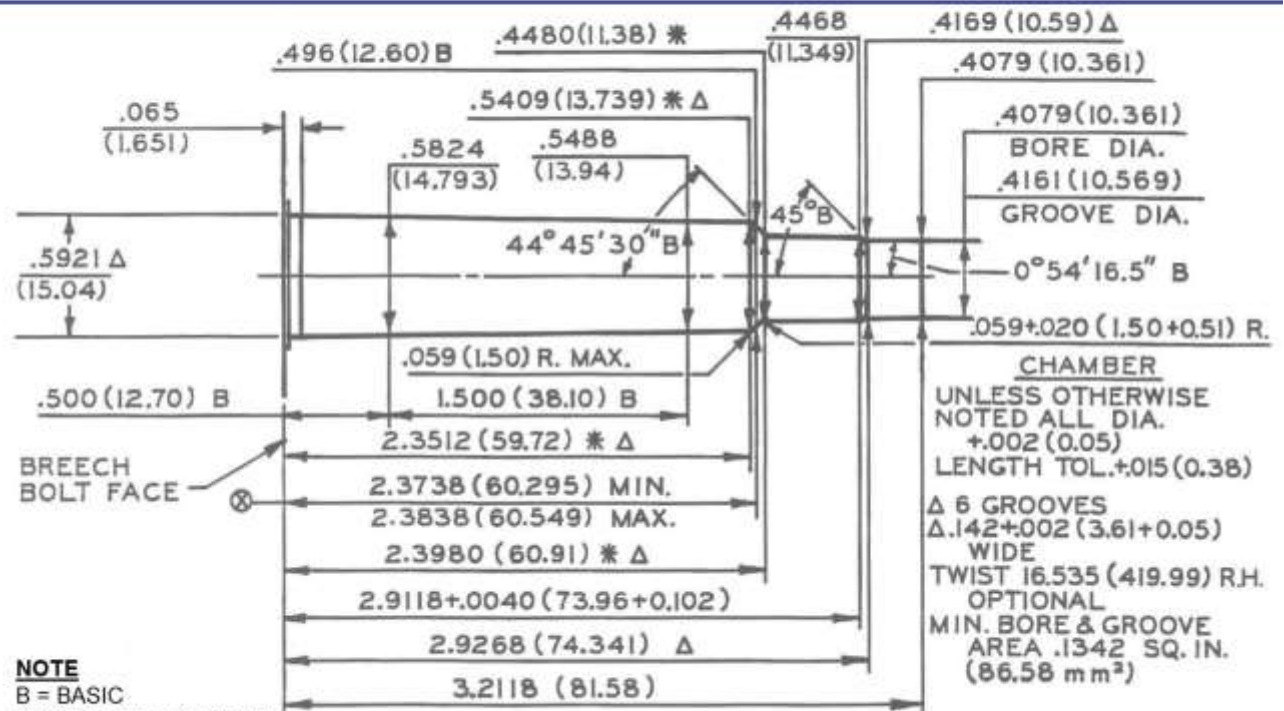
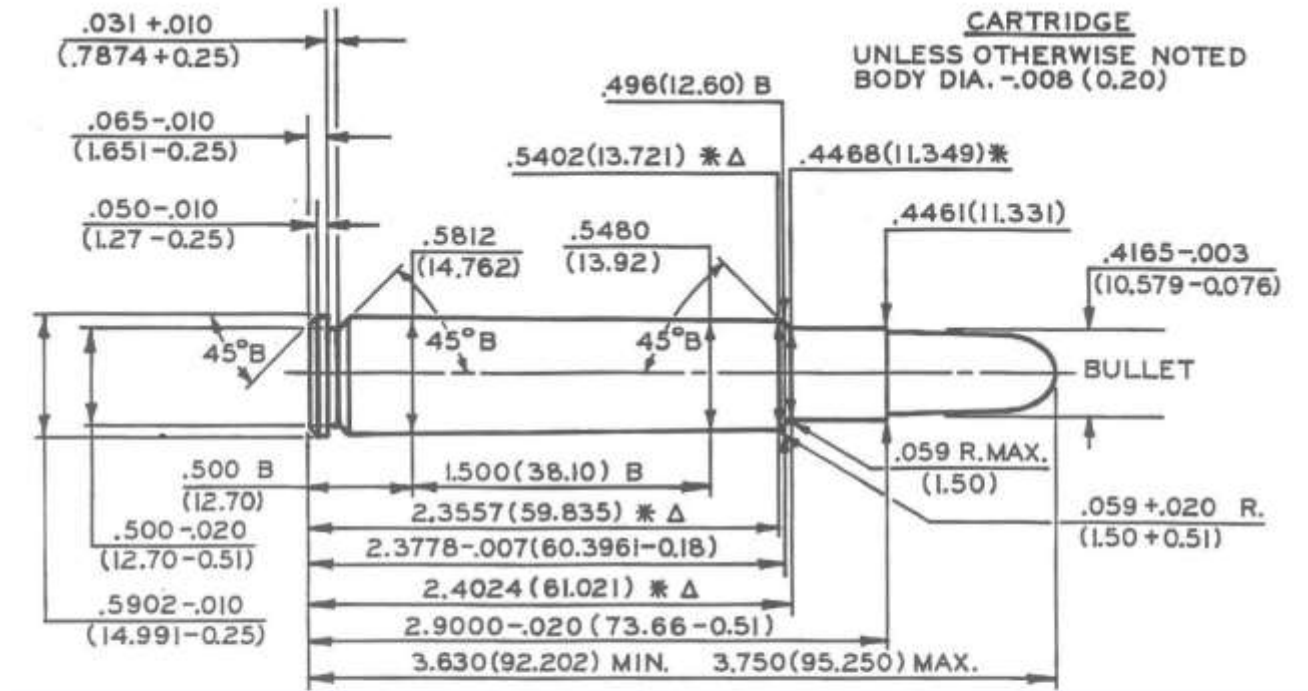

NOTE
 B = BASIC
 (XX.XX) = MILLIMETERS
 ⊗ = HEADSPACE DIMENSION Δ = REFERENCE DIMENSION
 * = DIMENSIONS ARE TO INTERSECTION OF LINES
 ALL CALCULATIONS APPLY AT MAXIMUM MATERIAL CONDITION (MMC)

NOTICE: This drawing is subject to change.
 Current version is available at www.saami.org.

MAXIMUM CARTRIDGE / MINIMUM CHAMBER

416 RUGER

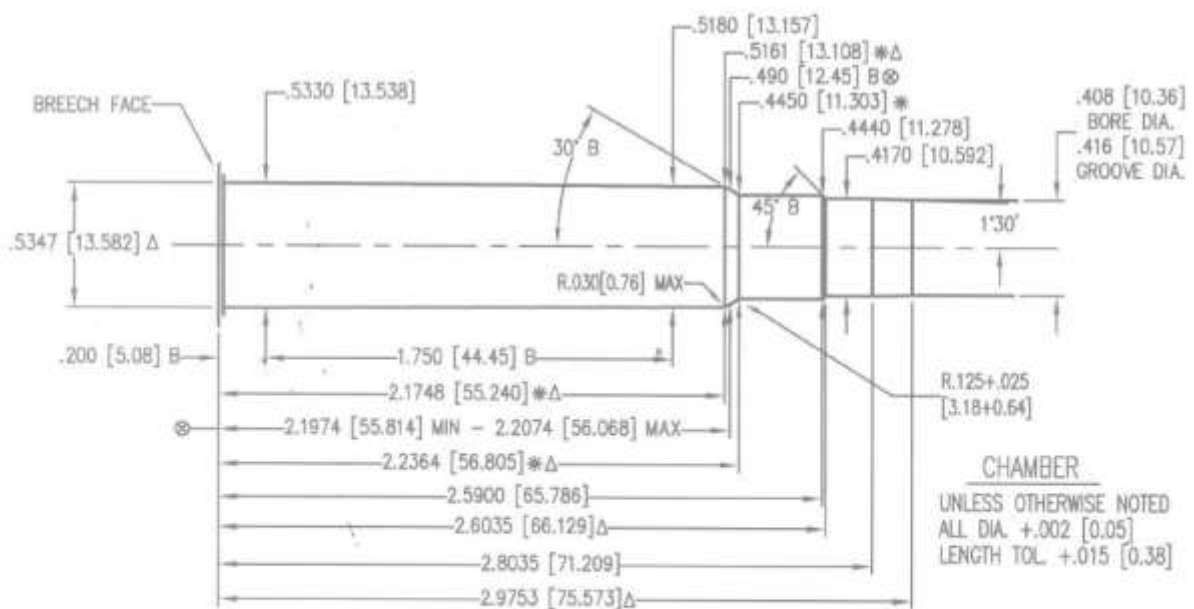
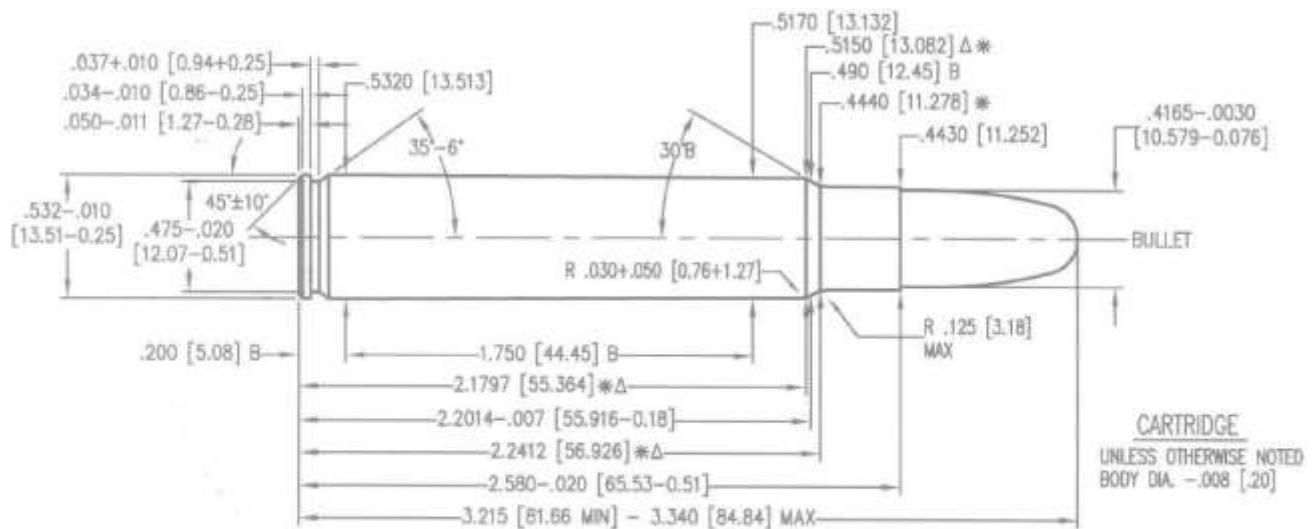

NOTE:
 B=BASIC
 [XX.XX]=MILLIMETERS
 ⊕ = HEADSPACE DIMENSION
 Δ = REFERENCE DIMENSION
 * DIMENSIONS ARE TO INTERSECTION OF LINES
 ALL CALCULATIONS APPLY AT MAXIMUM MATERIAL CONDITION (MMC)

OPTIONAL:
 Δ 6 GROOVES
 Δ.128+.002 [3.25+0.05] WIDE
 TWIST: 14 [355.6] R.H.
 MIN. BORE & GROOVE
 AREA: .1338 SQ. IN. [86.322 mm²]

NOTICE: This drawing is subject to change.
 Current version is available at www.saami.org.

MAXIMUM CARTRIDGE / MINIMUM CHAMBER

416 WEATHERBY MAGNUM

01/2001

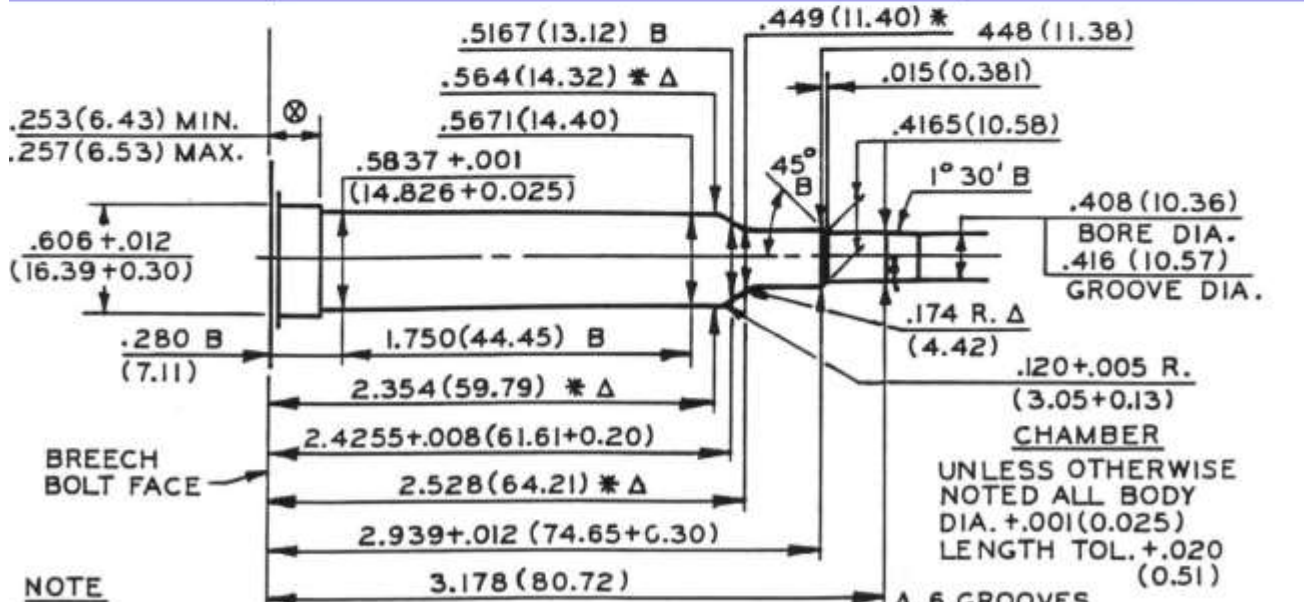
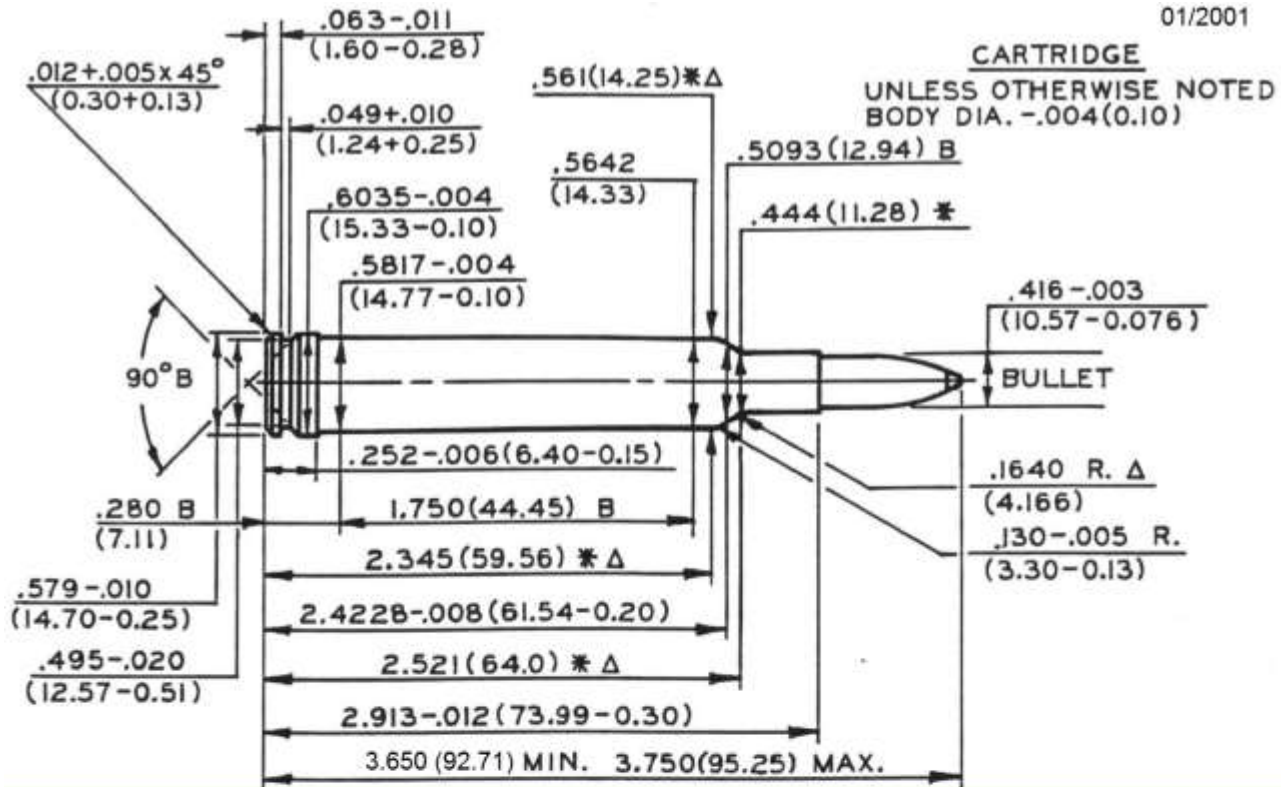

NOTE

B = BASIC
 (XX.XX) = MILLIMETERS
 ⊗ = HEADSPACE DIMENSION
 * DIMENSIONS ARE TO INTERSECTION OF LINES
 Δ REFERENCE DIMENSION
 ALL CALCULATIONS APPLY AT MAXIMUM MATERIAL
 CONDITION (MMC)

Δ 6 GROOVES
 Δ $.127+.002$ WIDE
 (3.226+0.05)
 TWIST 14 (355.6) R.H.
 OPTIONAL
 MIN. BORE & GROOVE AREA
 $.1338 \text{ SQ. IN. } (86.32 \text{ mm}^2)$

NOTICE: This drawing is subject to change.
 Current version is available at www.saami.org.

MAXIMUM CARTRIDGE / MINIMUM CHAMBER

44 REMINGTON MAGNUM

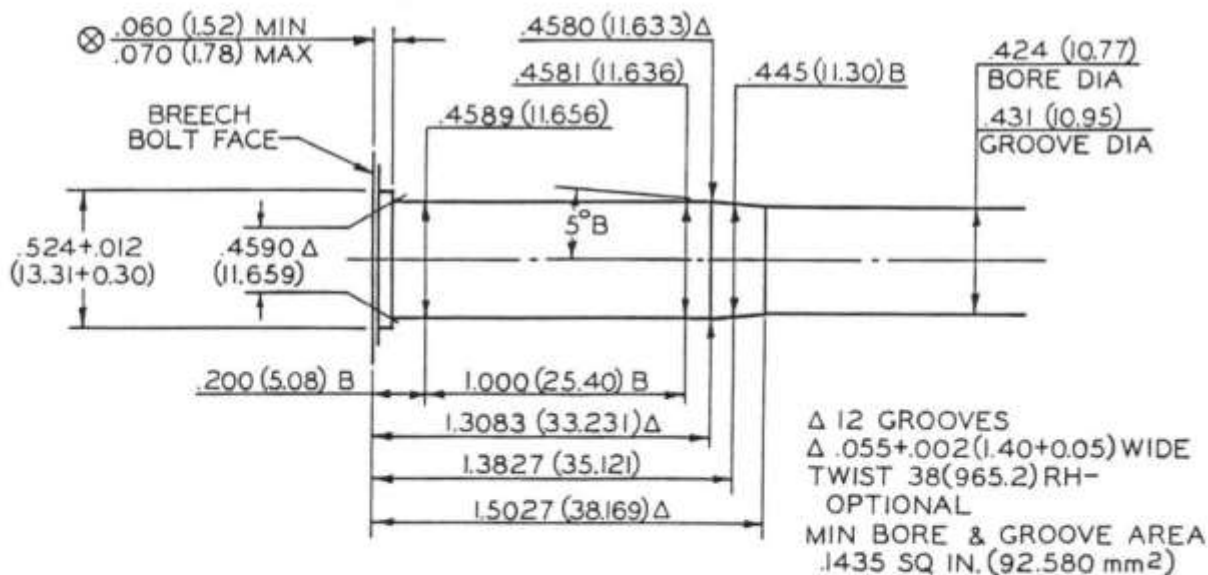
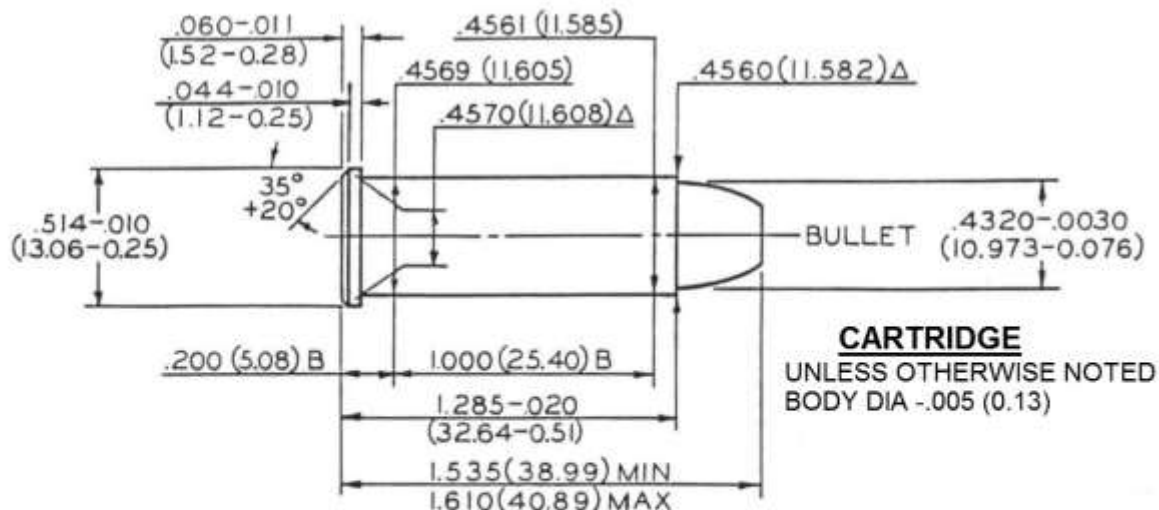

NOTE

- B = BASIC
- (XX.XX) = MILLIMETERS
- ⊗ = HEADSPACE DIMENSION
- Δ = REFERENCE DIMENSION
- * DIMENSIONS ARE TO INTERSECTION OF LINES
- ALL CALCULATIONS APPLY AT MAXIMUM MATERIAL CONDITION (MMC)

NOTICE: This drawing is subject to change.
 Current version is available at www.saami.org.

MAXIMUM CARTRIDGE / MINIMUM CHAMBER

44-40 WINCHESTER

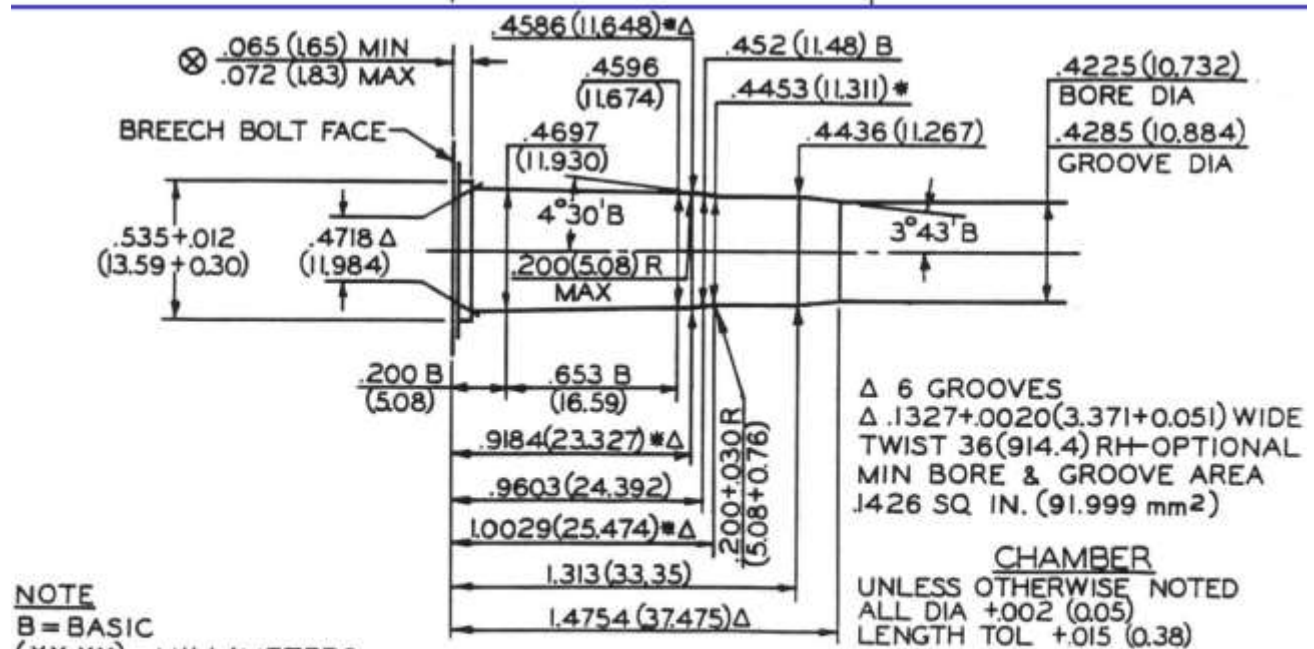
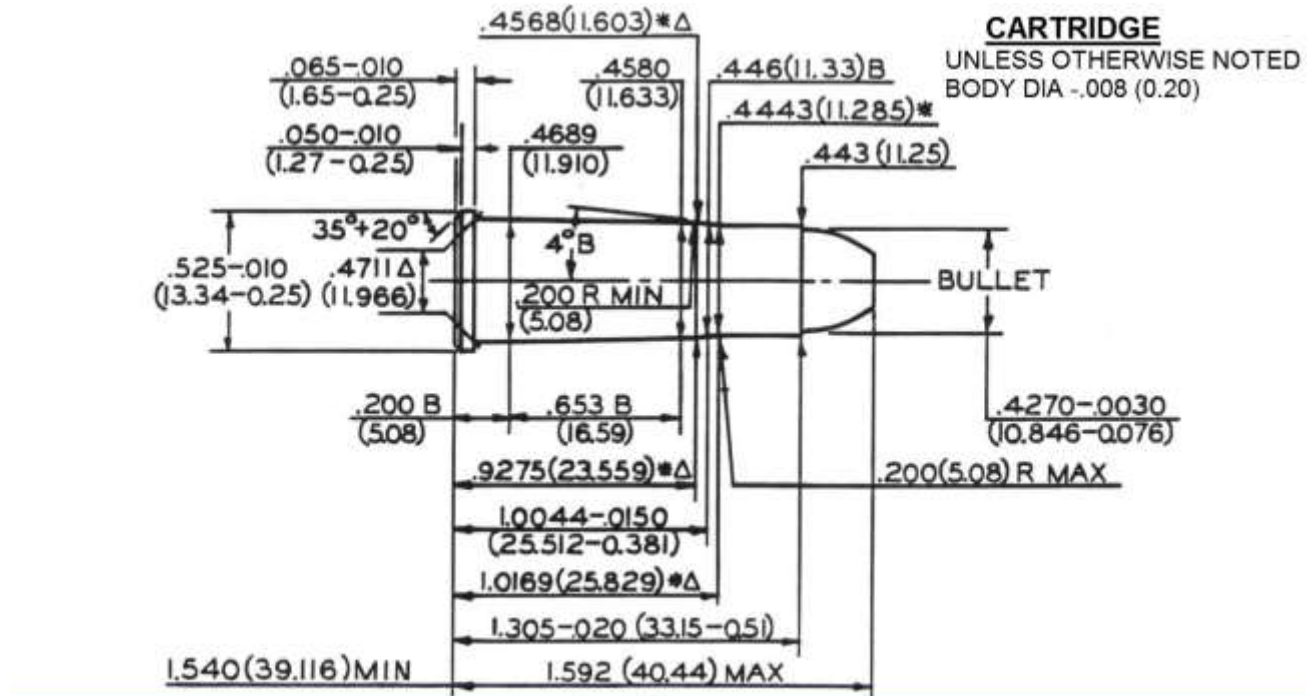

NOTE

- B = BASIC
- (XX.XX) = MILLIMETERS
- ⊗ = HEADSPACE DIMENSION
- Δ = REFERENCE DIMENSION
- * DIMENSIONS ARE TO INTERSECTION OF LINES
- ALL CALCULATIONS APPLY AT MAXIMUM MATERIAL CONDITION (MMC)

NOTICE: This drawing is subject to change.
 Current version is available at www.saami.org.

MAXIMUM CARTRIDGE / MINIMUM CHAMBER

444 MARLIN

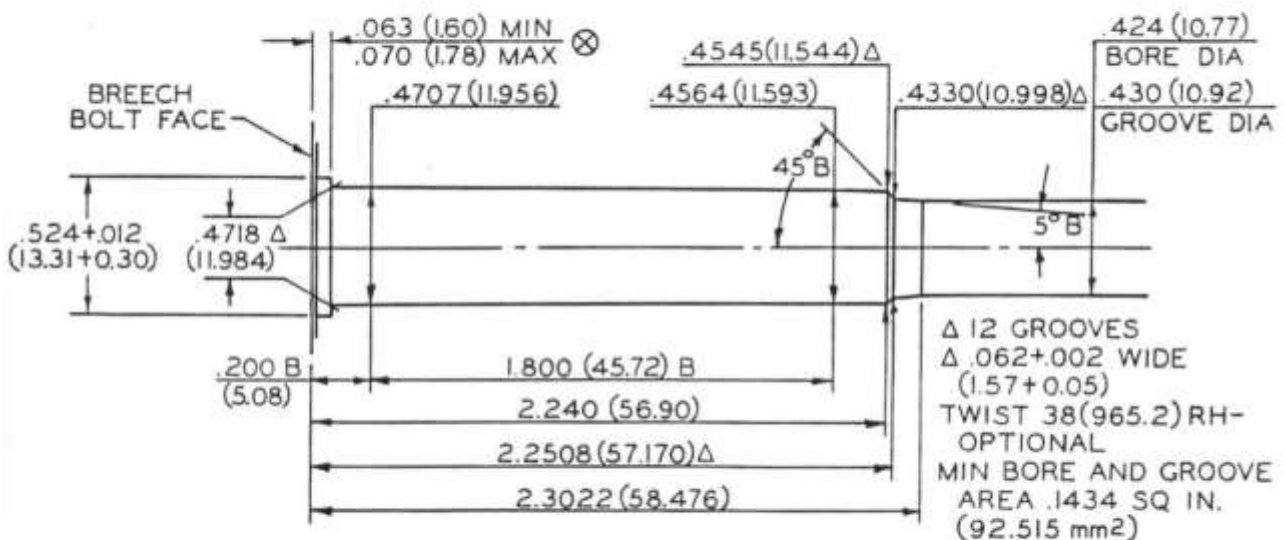
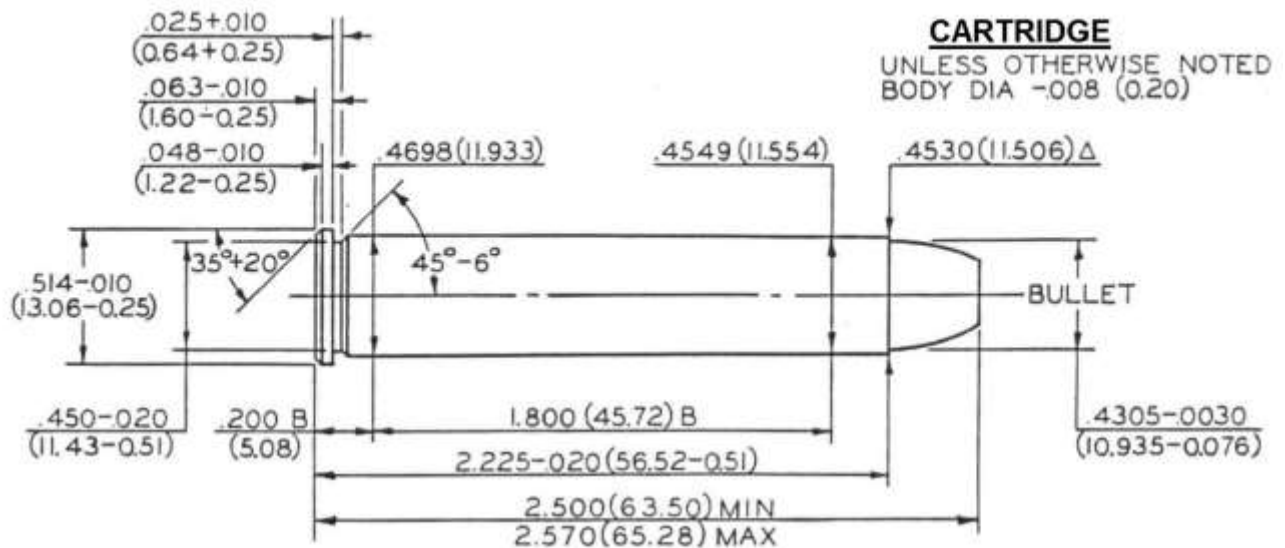

NOTE

- B = BASIC
- (XX.XX) = MILLIMETERS
- ⊗ = HEADSPACE DIMENSION
- Δ = REFERENCE DIMENSION
- * DIMENSIONS ARE TO INTERSECTION OF LINES
- ALL CALCULATIONS APPLY AT MAXIMUM MATERIAL CONDITION (MMC)

NOTICE: This drawing is subject to change.
 Current version is available at www.saami.org.

MAXIMUM CARTRIDGE / MINIMUM CHAMBER

45-70 GOVERNMENT

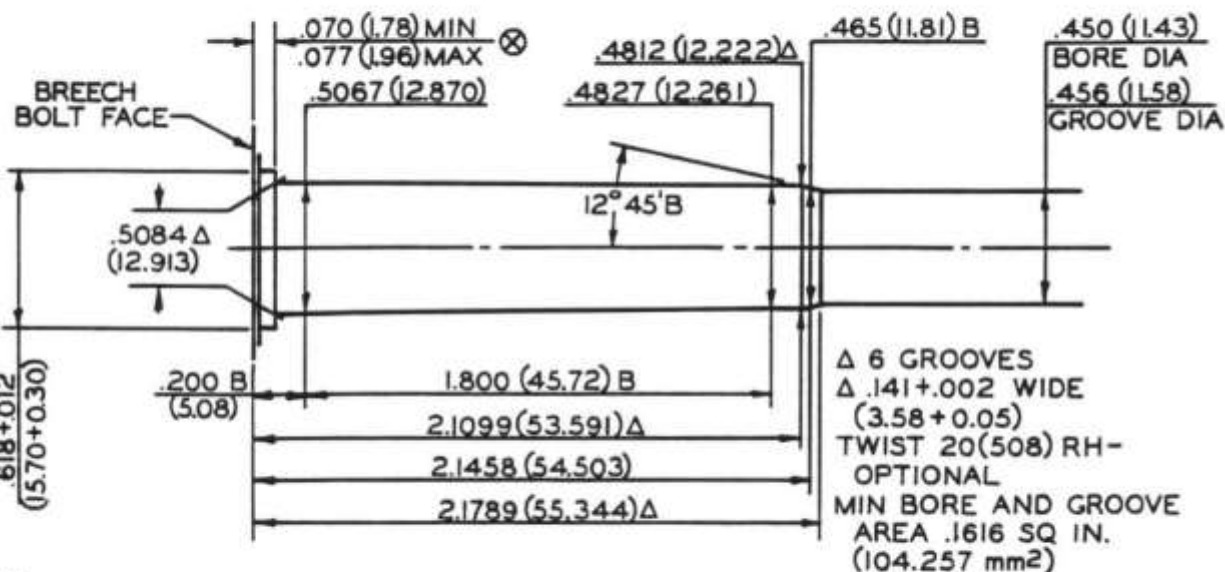
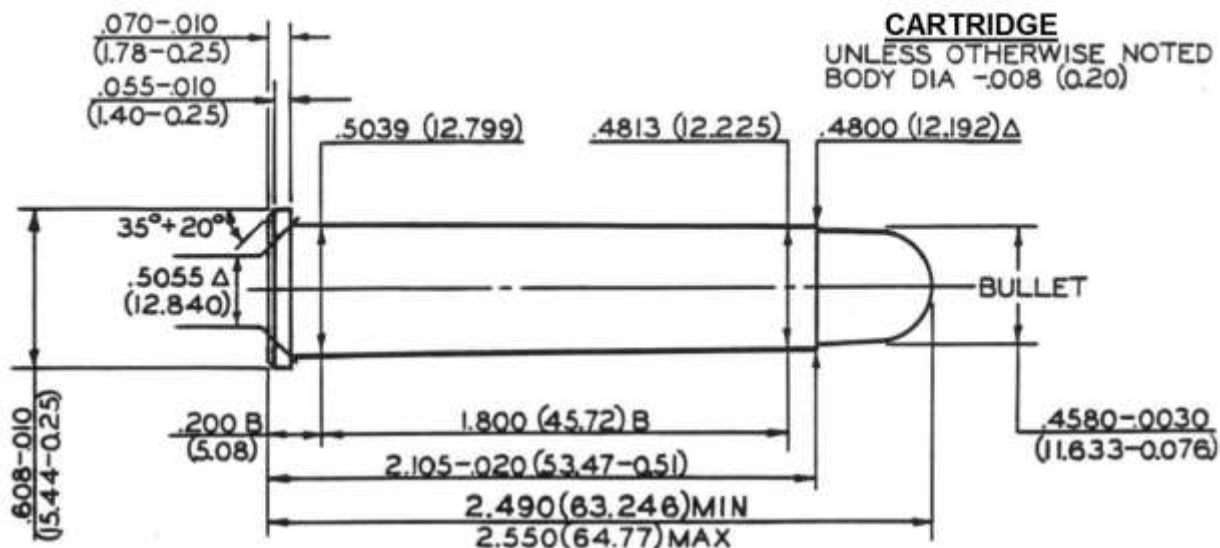

NOTE

B = BASIC
 (XX.XX) = MILLIMETERS
 ⊗ = HEADSPACE DIMENSION
 Δ = REFERENCE DIMENSION
 * DIMENSIONS ARE TO INTERSECTION OF LINES
 ALL CALCULATIONS APPLY AT MAXIMUM MATERIAL CONDITION (MMC)

CHAMBER

UNLESS OTHERWISE NOTED
 ALL DIA +.002 (0.05)
 LENGTH TOL +.015 (0.38)

NOTICE: This drawing is subject to change.
 Current version is available at www.saami.org.

MAXIMUM CARTRIDGE / MINIMUM CHAMBER

450 BUSHMASTER

ISSUED 02/01/2008

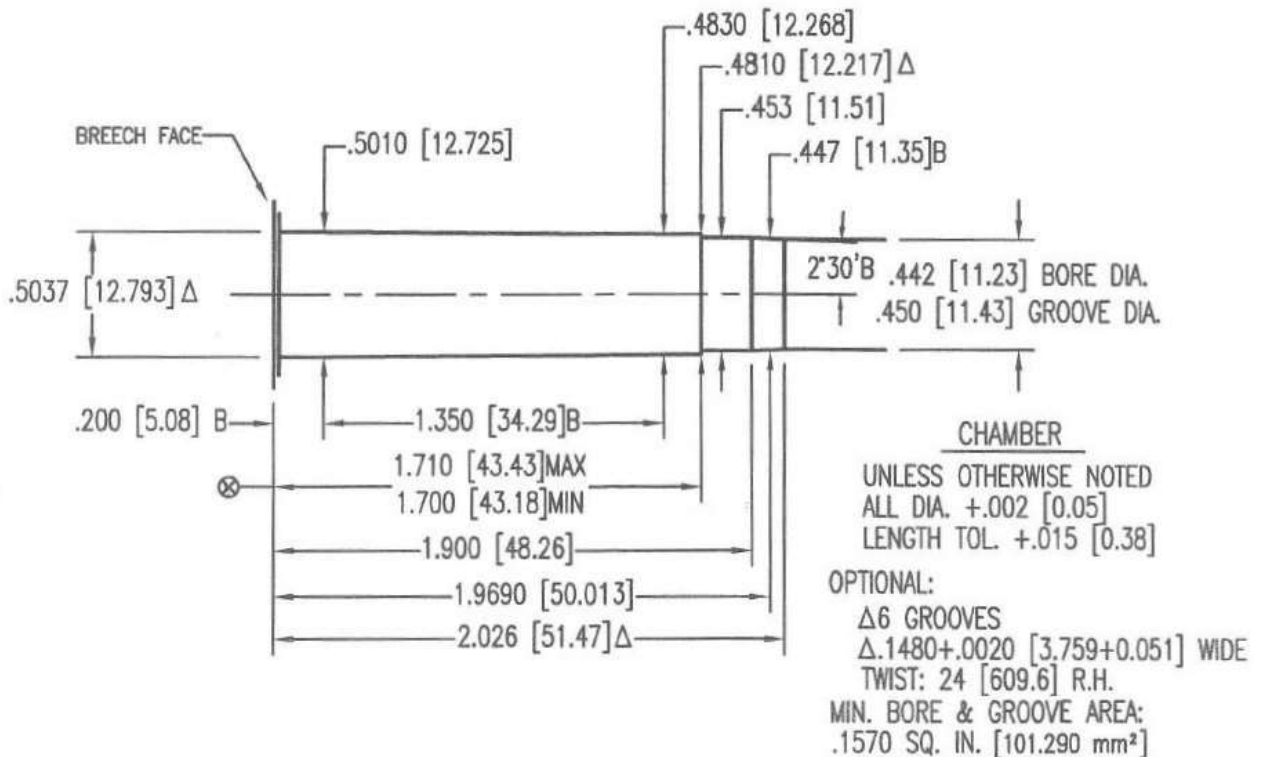
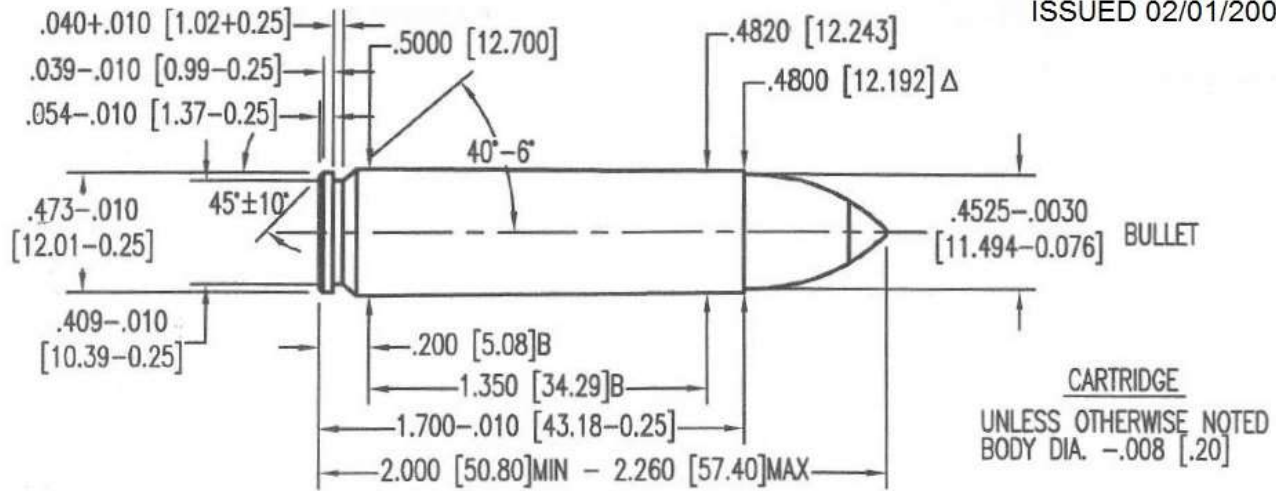

NOTE:

B = BASIC

[XX.XX] = MILLIMETERS

⊗ = HEADSPACE DIMENSION

⊗ = REFERENCE DIMENSION

✱ DIMENSIONS ARE TO INSECTION OF LINES

ALL CALCULATIONS APPLY AT MAXIMUM MATERIAL CONDITION (MMC)

450 BUSHMASTER

NOTICE: This drawing is subject to change.
 Current version is available at www.saami.org.

MAXIMUM CARTRIDGE / MINIMUM CHAMBER

450 MARLIN

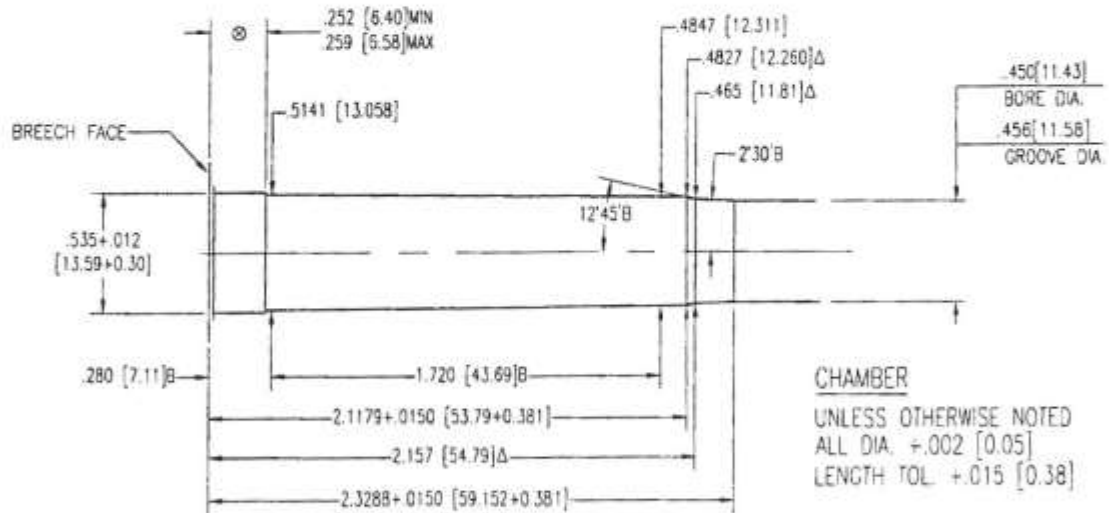
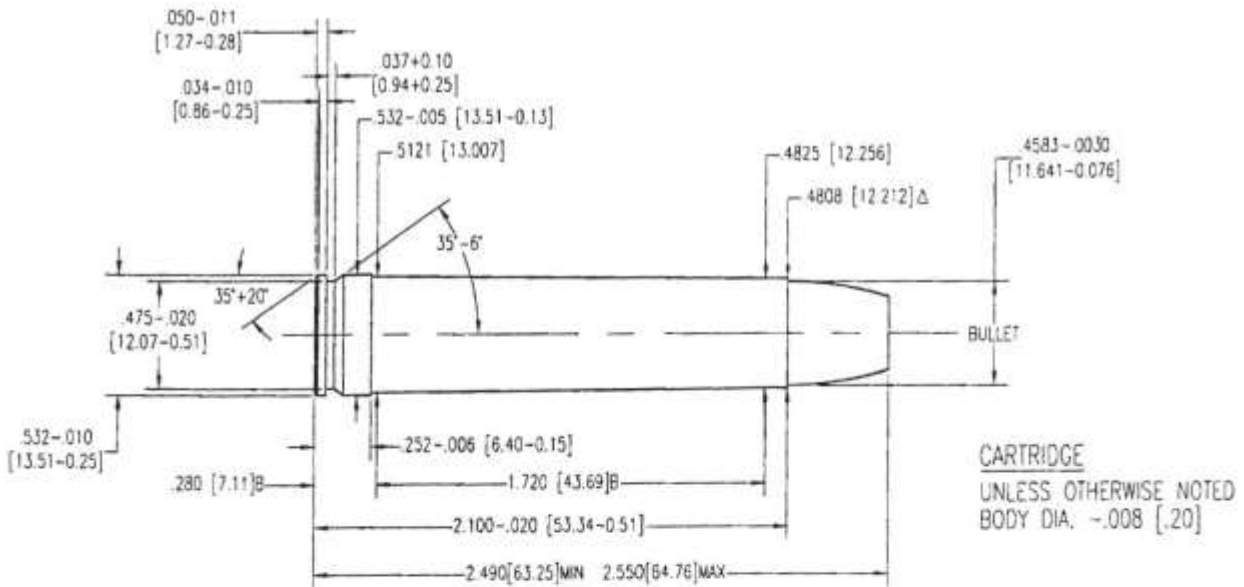

NOTE:
 B=BASIC
 [XX.XX]=MILLIMETERS
 ⊕ = HEADSPACE DIMENSION
 Δ = REFERENCE DIMENSION
 * DIMENSIONS ARE TO INTERSECTION OF LINES
 ALL CALCULATIONS APPLY AT MAXIMUM MATERIAL CONDITION (MMC)

6 GROOVES
 .141+.002 [3.58+0.05] WIDE
 TWIST: 20[508] RH - OPTIONAL
 MIN. BORE & GROOVE AREA:
 .1616 SQ. IN. [104.257 mm²]

NOTICE: This drawing is subject to change.
 Current version is available at www.saami.org.

MAXIMUM CARTRIDGE / MINIMUM CHAMBER

458 LOTT

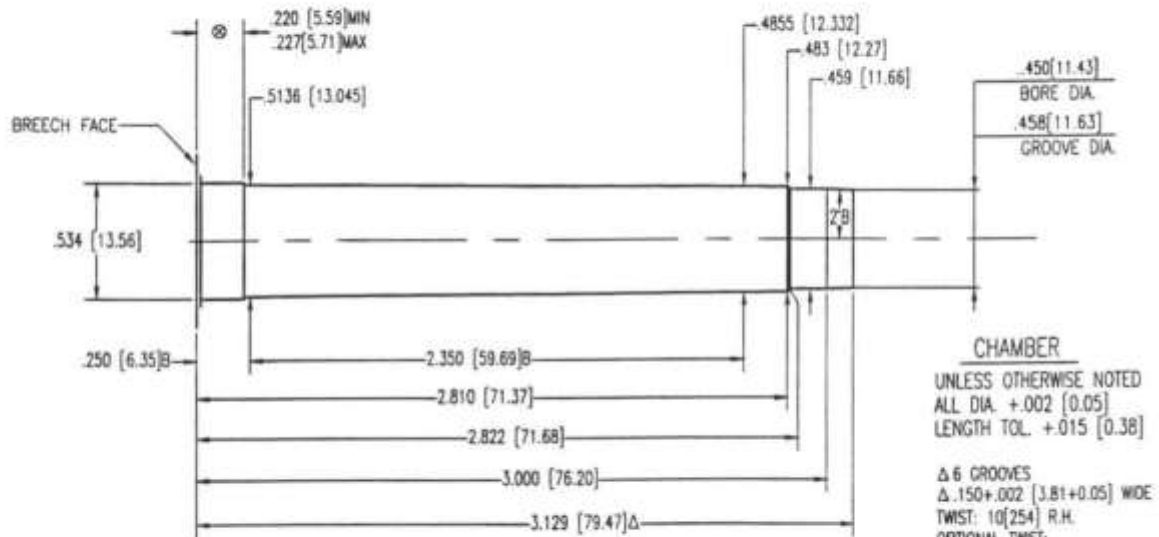
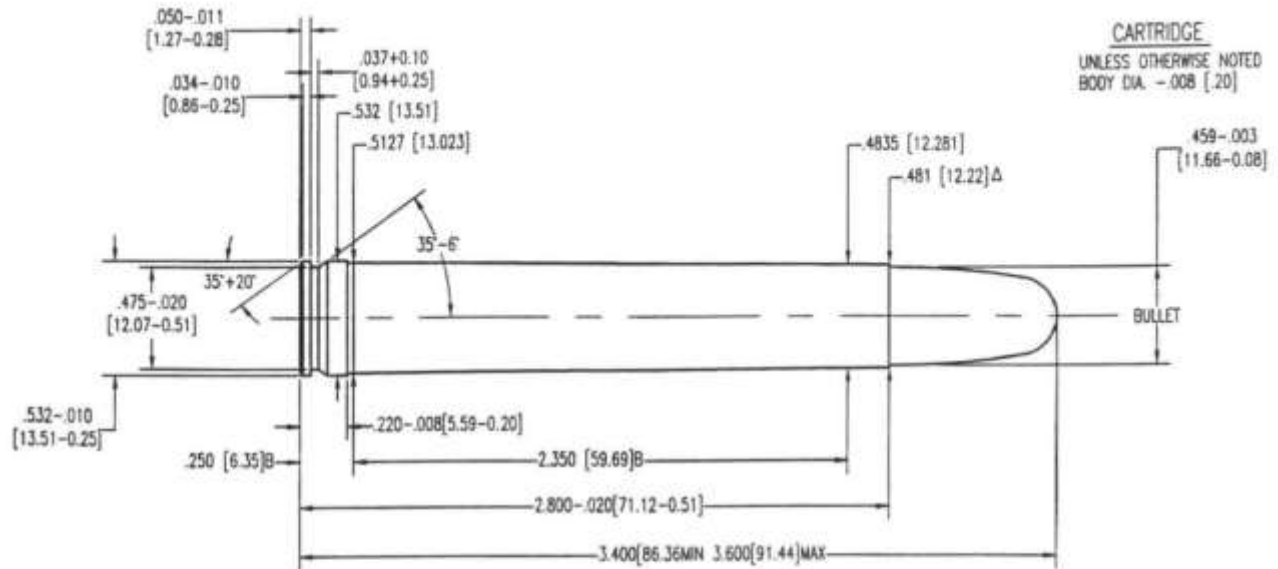

NOTE:
 B=BASIC
 [XX.XX]=MILLIMETERS
 \otimes = HEADSPACE DIMENSION
 Δ = REFERENCE DIMENSION
 *DIMENSIONS ARE TO INTERSECTION OF LINES
 ALL CALCULATIONS APPLY AT MAXIMUM MATERIAL CONDITION (VMC)

458 LOTT

NOTICE: This drawing is subject to change.
 Current version is available at www.saami.org.

MAXIMUM CARTRIDGE / MINIMUM CHAMBER

458 WINCHESTER MAGNUM

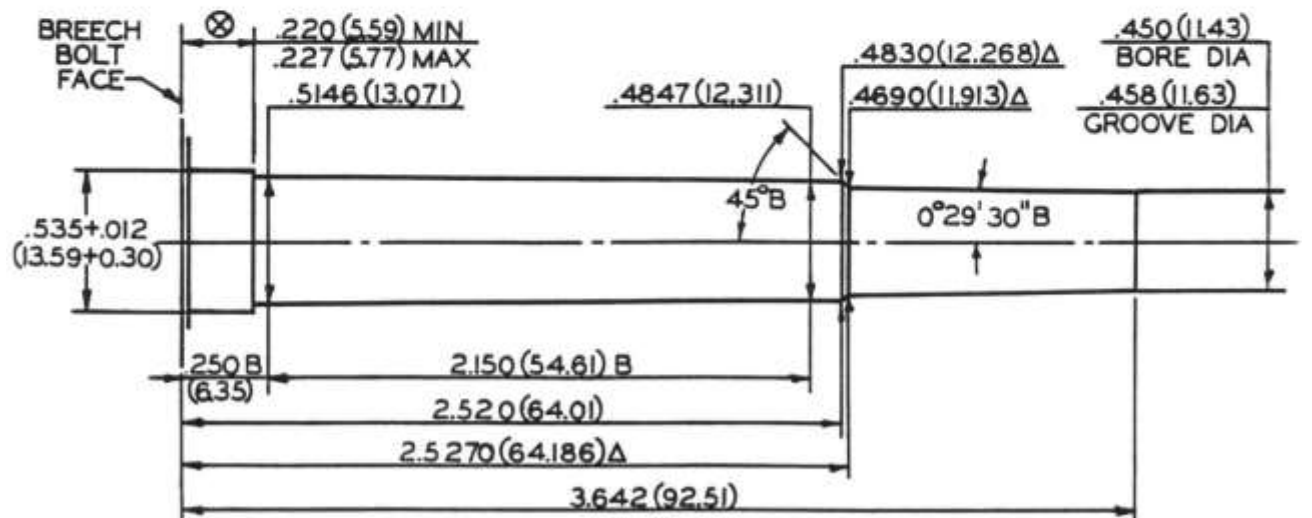
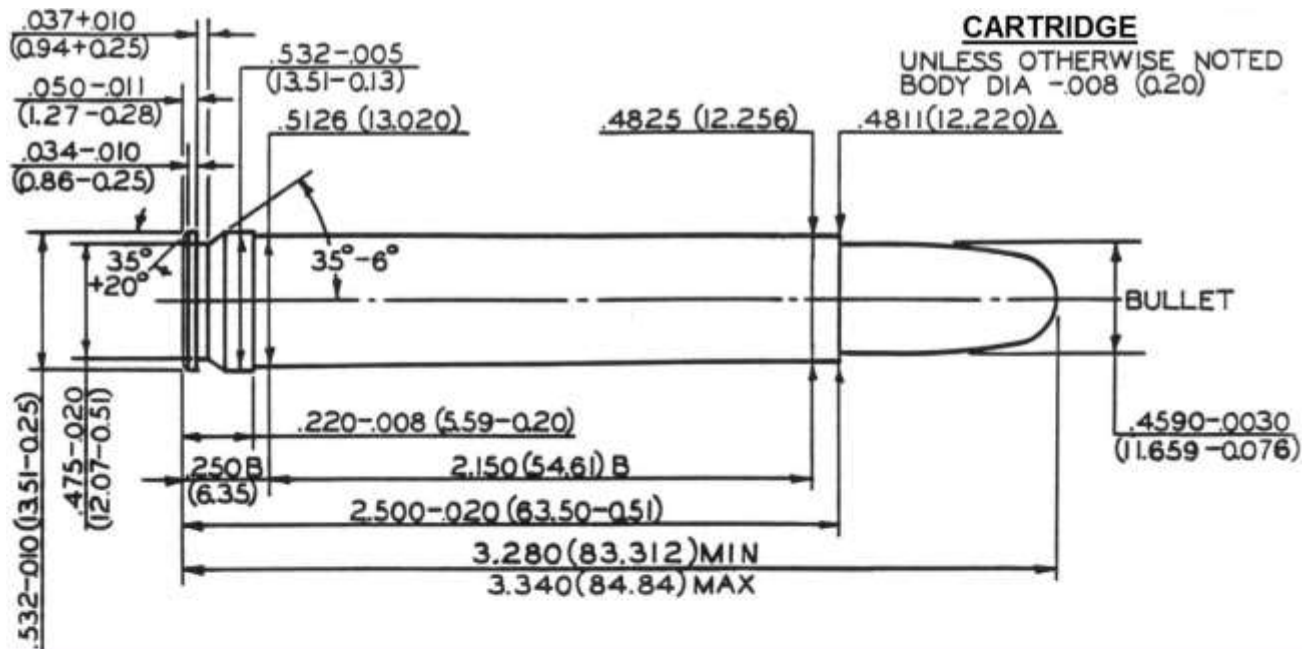

NOTE

- B = BASIC
- (XX.XX) = MILLIMETERS
- ⊗ = HEADSPACE DIMENSION
- Δ = REFERENCE DIMENSION
- DIMENSIONS ARE TO INTERSECTION OF LINES

Δ 6 GROOVES Δ .150+0.002(3.81+0.05) WIDE
 TWIST 14 (355.6) RH - OPTIONAL
 MIN BORE & GROOVE AREA .1627 SQ IN. (104.967 mm²)

CHAMBER

UNLESS OTHERWISE NOTED
 ALL DIA +0.02 (0.05) LENGTH TOL +.015 (0.38)

ALL CALCULATIONS APPLY AT MAXIMUM MATERIAL CONDITION (MMC)

458 WIN MAG

NOTICE: This drawing is subject to change.
 Current version is available at www.saami.org.

MAXIMUM CARTRIDGE / MINIMUM CHAMBER

470 NITRO EXPRESS

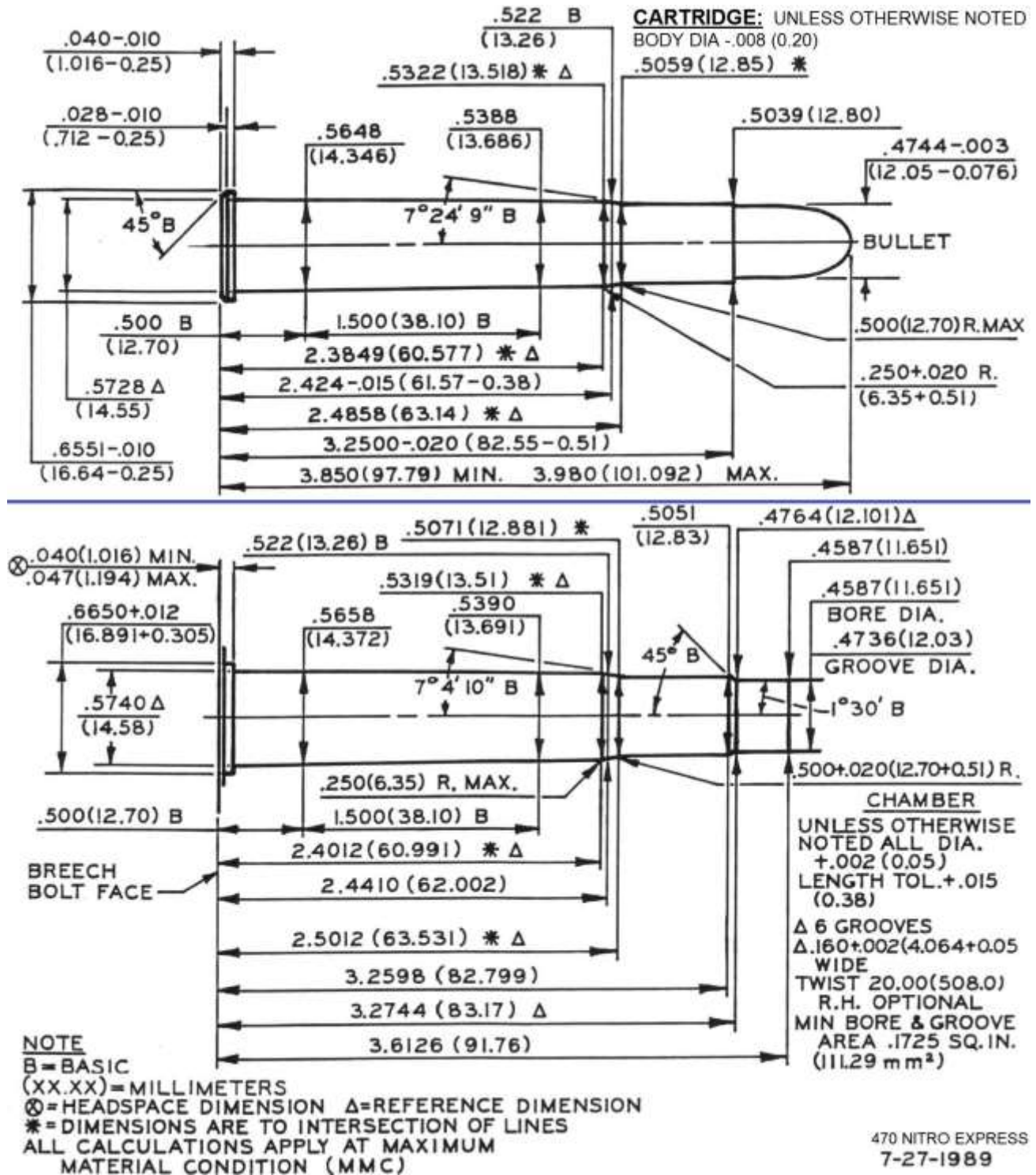

NOTICE: This drawing is subject to change.
 Current version is available at www.saami.org.

MAXIMUM CARTRIDGE / MINIMUM CHAMBER

475 TURNBULL

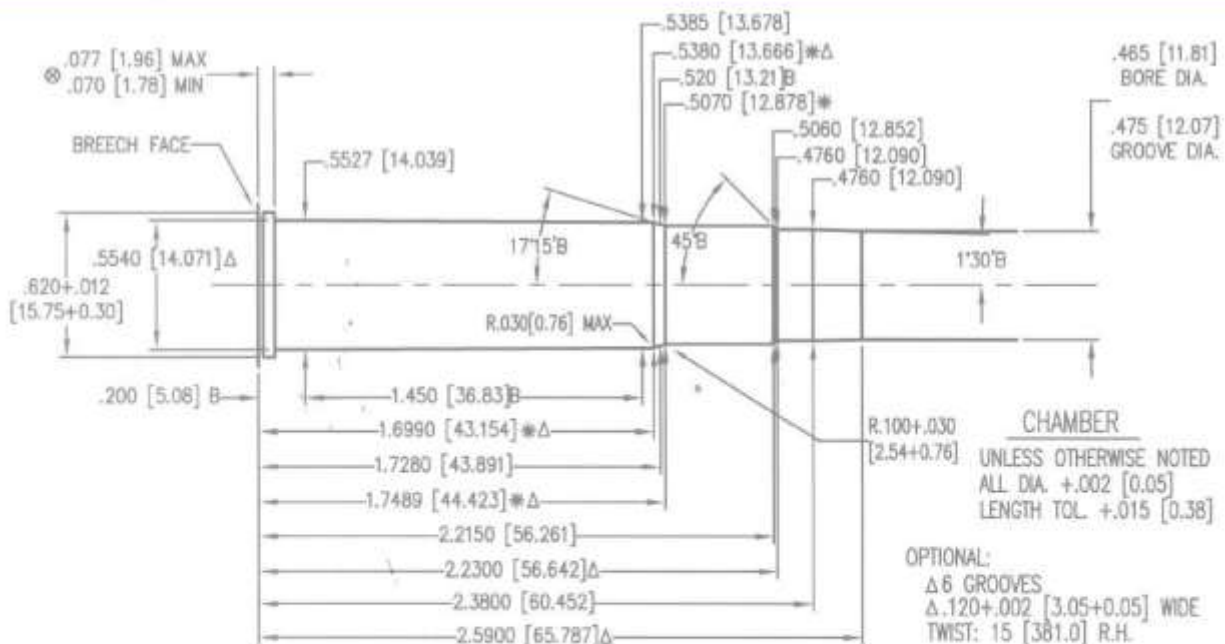
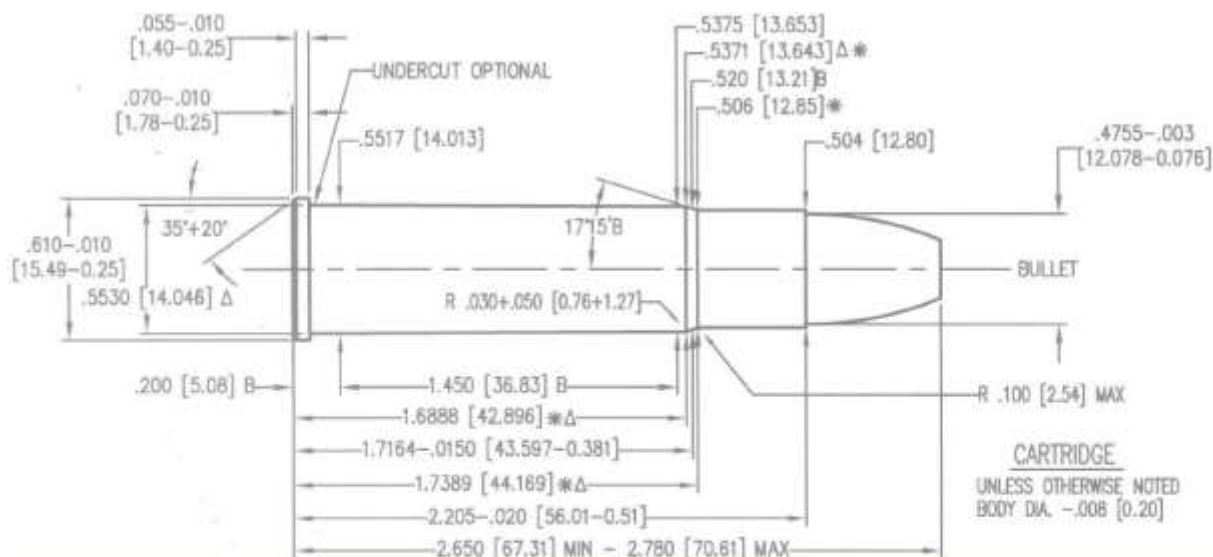

NOTE:
 B=BASIC [XX.XX]=MILLIMETERS
 \varnothing = HEADSPACE DIMENSION Δ = REFERENCE DIMENSION
 *DIMENSIONS ARE TO INTERSECTION OF LINES
 ALL CALCULATIONS APPLY AT MAXIMUM MATERIAL CONDITION (MMC)

475 TURNBULL

NOTICE: This drawing is subject to change.
 Current version is available at www.saami.org.

MAXIMUM CARTRIDGE / MINIMUM CHAMBER
500 NITRO EXPRESS 3"

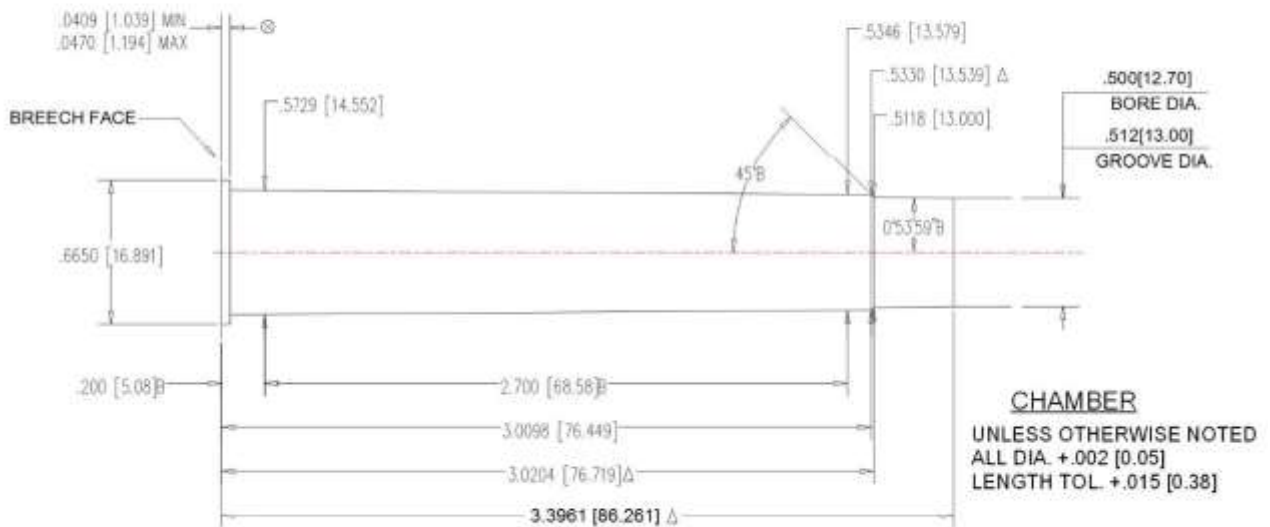
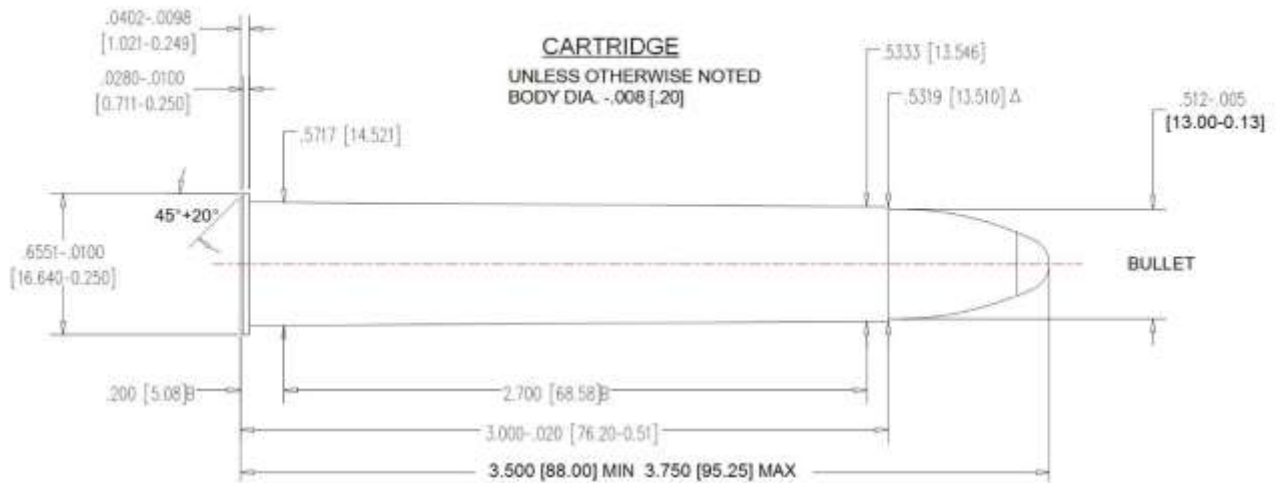

NOTE:
 B = BASIC
 ⊙ = HEADSPACE DIMENSION
 * = DIMENSIONS ARE TO INSECTIONS OF LINES
 ALL CALCULATIONS APPLY AT MAXIMUM MATERIAL CONDITION (MMC)

[XX.XX] = MILLIMETERS
 Δ = REFERENCE DIMENSIONS

Δ 7 GROOVES
 Δ .142+.002 [3.61+0.05] WIDE
 TWIST: 15[385] R.H.
 OPTIONAL TWIST: 10-20[254-508] RH-LH
 MIN. BORE & GROOVE AREA: .2022 SQ. IN. [130.52 mm²]
 500 NITRO EXPRESS 3"

DUMMY CARTRIDGE GUN FUNCTIONING

BASIC CARTRIDGE

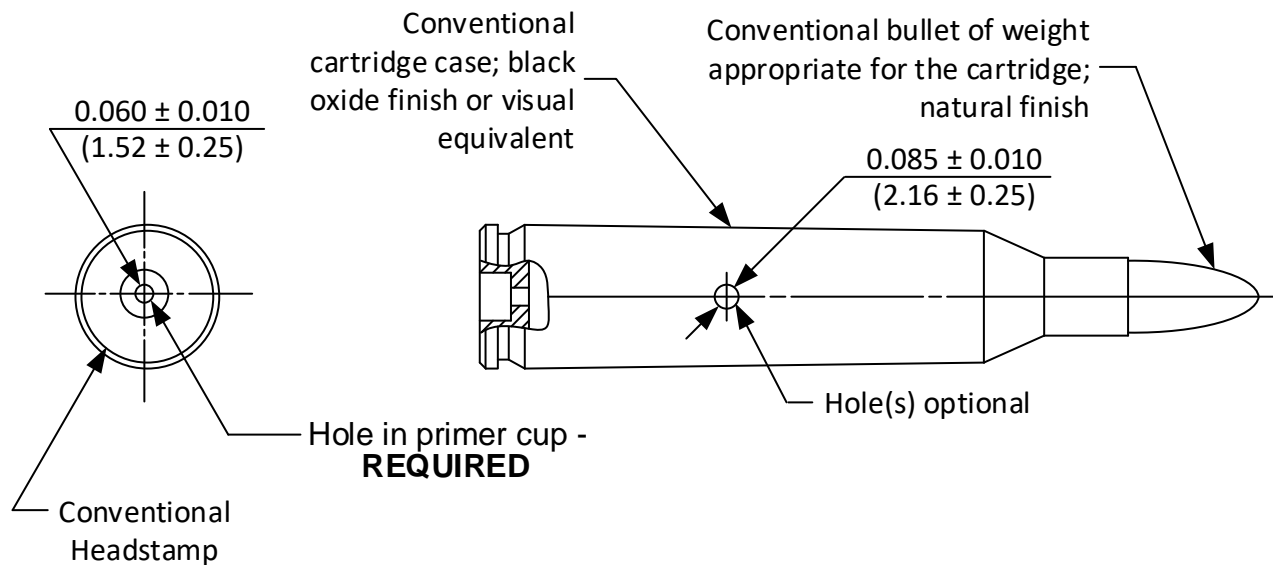

ALTERNATE CARTRIDGE

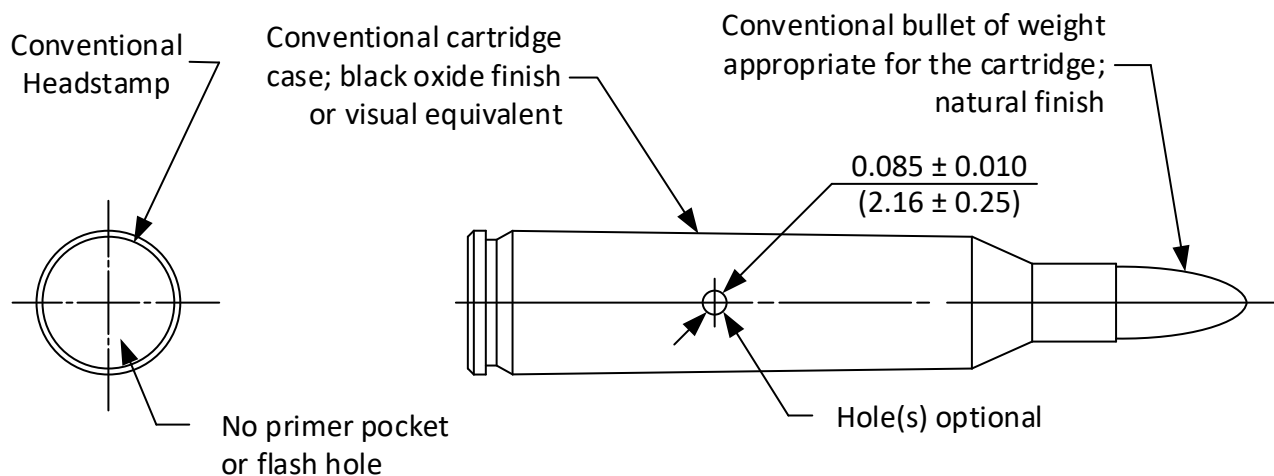

NOTE

Illustrates form only!

Pertinent dimensions shown on appropriate cartridge drawing.

(XX.XX) = millimeters

DUMMY CARTRIDGE DISPLAY

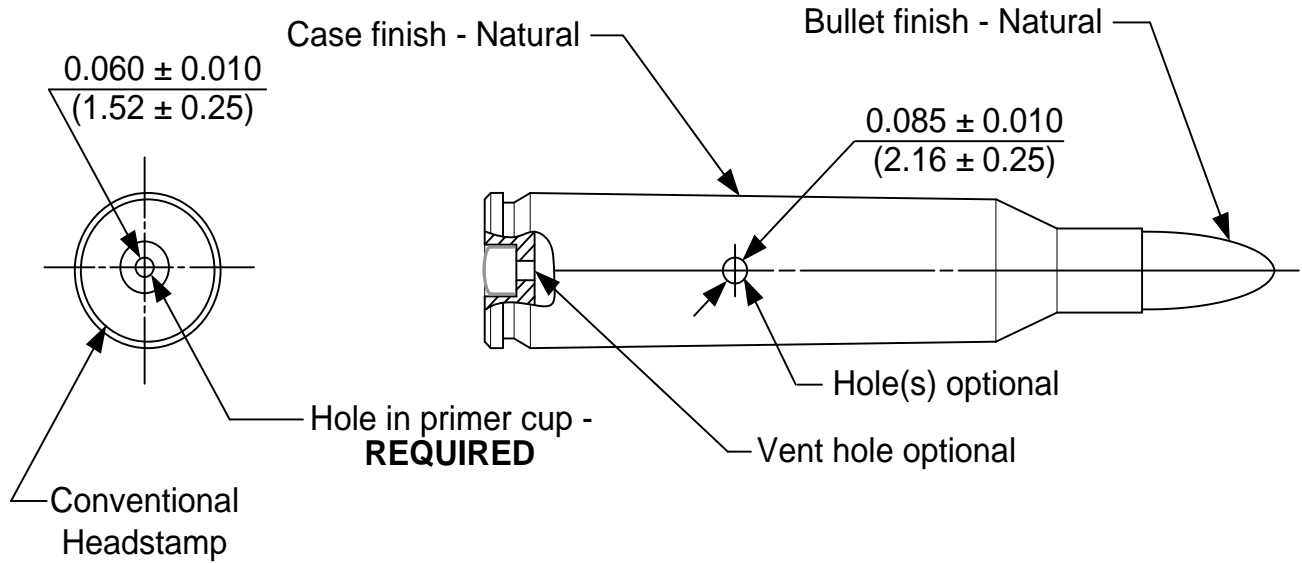

NOTE

Illustrates form only!

Pertinent dimensions shown on appropriate cartridge drawing.

(XX.XX) = millimeters

TOLERANCE – BULLET WEIGHT

1. Lead and lead-core bullets:

Less than 100 grains..... Nominal weight \pm 2.0%

Equal to or greater than 100 grains Nominal weight \pm 1.5%

2. Bullets of principally non-lead construction:

All bullet weights Nominal weight \pm 3.0%

**PROCEDURE:
 VELOCITY & PRESSURE TESTING**

I. SCOPE

- A. This procedure covers the testing of ammunition for assessment of velocity and pressure using either the copper crusher method of pressure measurement or with piezoelectric pressure transducers (“transducers”).

II. GENERAL

- A. When testing using copper crushers, velocities and pressures are measured separately. Velocity measurements should be made using a test barrel fitted with long pistons or velocity barrels (without piston holes). Pressure measurements should be made using test barrels fitted with short pistons and gas checks. Velocities observed during pressure testing with short pistons should be recorded for information.
- B. When testing using transducers, velocities and pressures are measured simultaneously.
- C. Recommended values for velocity and pressure of all centerfire rifle cartridges are tabulated in Section I. When required, a retest of double the original quantity may be fired with statistically equivalent tolerances.
- D. Velocities and pressures should be measured using horizontally-mounted test barrels in accordance with the drawings and descriptions listed in Section III.

III. EQUIPMENT

A. COMMON

<u>Item</u>	<u>Type</u>	<u>Alternate</u>
1. Universal receiver	“Frankford Arsenal”	or equivalent
2. Photoelectric screens	Oehler Model 55 or 57	or equivalent
3. Ballistic measurement system	Oehler Model 85	or equivalent

B. COPPER CRUSHER TESTING

<u>Item</u>	<u>Type</u>	<u>Alternate</u>
1. Test barrel	Piston type	Velocity barrel may be used in place of long piston measurements
2. Pistons	Short	---
3. Gas Checks	0.206”, oiled	---
4. Copper crushers	.146” x .400” or .225” x .400” as needed	---
5. Micrometer	Capable of measuring to 0.0005”	---
6. Tarage table	Specific for lot of crushers in use	---

C. TRANSDUCER TESTING

<u>Item</u>	<u>Type</u>	<u>Alternate</u>
1. Charge Amplifier	PCB, Model 443B02	or equivalent
2. Voltmeter, Peak Capture	PCB, Model 444A152	or equivalent
3. Transducer	PCB, Model 117BXXX	or equivalent
4. Low Noise Cable	PCB, Model 003AXXX	or equivalent

5. Integrated Data
Acquisition System

Oehler Research, Inc.,
System 85

or equivalent

IV. HANDLING OF AMMUNITION

- A. Cartridges to be tested should be placed in a vertical position with primer-end down in a recessed holding block.
- B. When the appropriate test barrel has been properly serviced and the chronograph reset, a cartridge should be lifted vertically from the block. It should be rotated slowly, end over end, in a vertical plane through 360° pausing momentarily when the powder is at the bullet end and again when the powder is at the primer end.
- C. The cartridge is then rotated slowly, a minimum amount to enter the chamber, keeping the primer end in the lowest possible position until inserted gently and carefully into the chamber.
- D. The cartridge should be seated in the chamber as far as practicable with the fingers. The bolt or breech mechanism should be closed gently in order not to disturb the position of the powder in the cartridge case. The object of this method of handling cartridges is to position the propellant powder at the primer end of the cartridge case by permitting it to fall gently against the primer while rotating the case.
- E. The rate of fire should not be rapid enough to cause excessive heating of the barrel. The time between rounds depends on the equipment, as the barrel may be cooled by a constant stream of air on the outside or by directing air through the bore after each ten rounds.
- F. Ammunition conditioning should be between 60° - 80°F (15.6° - 26.7°C).
- G. A minimum of one and up to three warming shots should be fired before firing each series for record. The velocity and/or pressure of these shots may be recorded, but should not be included in the record of the sample.

V. PRESSURE DETERMINATION

A. COPPER CRUSHER TESTING

- 1. Oiling of the gas check is extremely important as a poor gas seal will cause erosion of the piston hole and piston causing erroneous readings before the barrel bore and chamber are worn out. Use SAE 30 oil (see Section III). Gas checks should be placed in a shallow container of oil. Each gas check is then blotted on absorbent material before insertion in the piston hole.
- 2. Insert oiled gas check with open end toward the chamber into the piston hole and seat to approximately one-half of the depth of the hole with the seating tool (see Section III).
- 3. Dip piston shank in oil and drain until but one drop of oil remains. Scrape the remaining drop from the bottom of the piston or blot remaining oil on a flannel patch.
- 4. Insert piston in piston hole and seat on gas check manually. Do not force by striking or hammering.



CAUTION: The piston must be checked to make sure it slides freely, but not loosely, in the piston hole at all times. If the piston does not slide freely, it should be withdrawn from the piston hole and examined. Any black deposits should be removed with worn crocus cloth. If the piston is still not free in the piston hole, the hole should be cleaned with worn crocus cloth.

5. Insert cartridge to be tested in chamber of standard velocity and pressure test barrel in the manner described in paragraphs IV(B) through IV(D), above.
6. Using finger pressure, push the piston down into the piston hole until the piston/gas check is fully seated.
7. Center crusher cylinder appropriate for the cartridge under test upon the head of the piston. Slide the anvil bridge so as to center it over the crusher/piston and securely tighten the set screws on the bridge. Gently tighten the anvil against the crusher cylinder using light finger pressure.



CAUTION: Overtightening the anvil can cause precompression of the crusher cylinder and affect the subsequent pressure reading. Use care to not over-tighten the anvil.



CAUTION: The face of the piston head, face of set screw and faces of crusher must be free from oil.

8. The breech mechanism should be closed gently.
9. After firing the cartridge, the compressed crusher cylinder should be removed and measured for remaining length. Pressure is determined from this length by the use of the Tarage Table, furnished with the cylinders, for the piston diameter used.
10. The piston is removed and the gas check and the disk blanked from the cartridge case by internal gas pressure is removed after each shot by driving the gas check downward with the knockout tool (see Section III) into the fired cartridge case.
11. The fired cartridge case containing the gas check and disk blanked from the cartridge case is removed from the chamber.



CAUTION: The chamber and bore should be checked to make certain that the barrel is unobstructed before proceeding further.

12. For subsequent shots in a series, the procedure shown in paragraphs V(A)(1) through V(A)(10) are repeated.

B. PIEZO-ELECTRIC TRANSDUCER TESTING

1. EQUIPMENT PREPARATION

- 1.1 Refer to the SAAMI-recommended piezo pressure transducer installation in a pressure barrel illustrated in Section III.
- 1.2 The charge amplifier and peak capture voltmeter should have a certified calibration traceable to the National Institute of Standards and Technology.

2. INITIAL SET-UP

- 2.1 Turn on the electronic equipment and allow to stabilize as recommended by the manufacturer.
- 2.2 Inspect the transducer mounting cavity in the pressure barrel to assure that the seal seat is free of dirt and any other foreign matter.
- 2.3 Mount transducer with steel spacer rings into the test barrel as described in PCB Operating Instructions Manual.
- 2.4 Loosen, but do not remove, the slotted clamp.
- 2.5 Thread the transducer into the mounting port. Adjust the slotted clamp to allow guide pin to enter guide hole. Continue to turn transducer nut into the mounting port. When transducer bottoms, tighten the slotted clamp and torque the transducer as recommended by the manufacturer.
- 2.6 It is essential that the sensing surface of the transducer be flush with the chamber inside diameter. Care must be exercised to obtain correct depth as well as exact rotational alignment. Depth adjustment is accomplished by the use of various thickness spacers. In order to set the depth exactly it may be necessary to hone the spacers to the desired thickness.
- 2.7 Connect equipment as shown in on page 178
 - a. **NOTE:** Configurations 1 and 2 are interchangeable.

IMPORTANT: Always switch the amplifier to the “zero lock” mode by pressing the “ZERO” button before making connections to the Model 443B02, and allow switch to remain in this position during such connections. This protects the FET input stage against possible gate damage from excessive accumulated static charge.

- 2.8 Set the charge amplifier controls for short time constant, transducer sensitivity to the slope (m) obtained from the transducer least square line equation, output sensitivity to 0.100 mV/unit, and set the amplifier to operating mode (releasing the “zero lock” by pressing the “ZERO” button a second time).
- 2.9 Select digital peak meter, positive input, peak mode, and 10-volt range.
- 2.10 Take note of the transducer offset value (P) obtained from the least square line equation. This value will be used later in making final peak pressure determination.
 - (a) The offset value may also be dialed into an instrumentation system capable of providing direct peak pressures without data manipulation.

3. PROCEDURE

- 3.1 Reset all pressure instrumentation and assure that the peak meter digital display reads all zeros. Test rounds may now be fired.
- 3.2 For each round fired, the pressure reading on the digital display should be recorded and pressure instrumentation reset.

4. PEAK PRESSURE DETERMINATION

- 4.1 To determine peak pressures, add as required, the pressure offset value to the pressure readings obtained in the firing test. Adding the offset value is not required if it is dialed in on the peak meter.

VI. VELOCITY DETERMINATION

- A. Handling of the ammunition should be in accordance with the instructions in paragraph IV.
- B. Photoelectric screens should be arranged in accordance with the arrangement shown on page 224, “*Equipment: Schematic Layout of Velocity Screens*”.
- C. A table of time of flight vs. velocity should be used to determine instrumental velocity at 15 feet (4.57 m), nominal, from the gun muzzle (not required when using direct reading equipment).
- D. It is recommended that a blast shield be positioned between the muzzle of the Universal Receiver test barrel and the first velocity screen to minimize possibility of premature triggering of the velocity screens. With velocities below the speed of sound, the muzzle blast and/or muzzle flash will reach the screen before the bullet and may cause premature triggering of the screen. For example, premature triggering of the first screen will result in abnormally low velocity readings. Premature triggering of both screens will result in velocity readings which correspond to the speed of sound (approximately 1,120 fps at sea level and normal atmospheric conditions).
 - (i) The blast shield should be made of rigid, opaque material of sufficient strength to withstand the shock wave but not be resistant to the passage of the projectile.

VII. RECORDING OF TEST RESULTS

- A. The following data should be recorded for each series of shots fired for velocity and pressure.
 1. Ammunition Data
 - 1.1 Date of test
 - 1.2 Nominal cartridge identification
 - 1.3 Cartridge caliber
 - 1.4 Bullet weight and type
 - 1.5 Powder charge, type, and lot
 - 1.6 Priming
 - 1.7 Type of lubricant (if any)
 - 1.8 Code or date of loading
 2. Average velocity, uncorrected.
 3. Average pressure, uncorrected.
 4. Maximum and minimum individual velocity.
 5. Maximum and minimum individual pressure.
 6. Extreme variation (range) of velocity.
 7. Extreme variation (range) of pressure.
 8. Other statistical indication of variation (optional).
 9. Correction to results from firing Reference Ammunition (optional).
 10. Corrected average velocity (optional).
 11. Corrected average pressure (optional).
 12. Recommended values
 - 12.1 Average velocity

- 12.2 Average pressure
 - 12.3 Velocity and pressure variation
 - 13. Test firearm and range data
 - 13.1 Barrel length and serial number
 - 13.2 Barrel history
 - 13.3 Transducer serial number / copper crusher lot number
 - 13.4 Type of chronograph and screens
 - 14. Test personnel.
-

VIII. USE OF REFERENCE AMMUNITION

- A. Purpose
 - 1. Reference ammunition, assessed by firings at the ranges of member companies, is available for calibrating ranges, firearms and other equipment for velocity and pressure only.
 - B. Supply
 - 1. On request, the SAAMI Technical Office¹ will supply information on the manufacturer of specific Reference Ammunition. The method of identifying Reference Ammunition is shown in Section II.
 - 2. Requests for Reference Ammunition should be addressed to the manufacturer of the specific cartridge.
 - C. Assessment
 - 1. Details of the assessment tests are shown in Section II.
 - D. Clearing House
 - 1. Results of assessment tests of Reference Ammunition are tabulated, analyzed and distributed by the SAAMI Technical Office.
 - E. Corrections
 - 1. For method of applying corrections to tests of service loads see Section II.
 - F. Calibration
 - 1. For method of calibrating ranges and equipment, see Section II.
-

IX. TEST BARREL CLEANING

- A. Test barrels should be cleaned regularly using solvents, brushes and/or other equipment as dictated by the type and severity of fouling in the test barrel.

¹ Refer to Section III – page 223 for current contact information for the SAAMI Technical Office.

VELOCITY & PRESSURE BARRELS: QUALIFICATION

All barrels are not necessarily suitable for use in determining pressure or velocity levels, even though they may conform to the dimensions given on the appropriate Standard Velocity and Pressure Barrel drawing in this Standard. New barrels may require a number of rounds to be fired to remove sharp corners or burrs resulting from the manufacturing process. Barrels in service do not have an unlimited life and may become unserviceable from wear and erosion. There is no predictable number of rounds to which a barrel should be exposed before use for pressure and velocity determinations, nor is there a predictable round life for such equipment.

The following procedure is suggested for determining the suitability of any barrel for pressure and velocity test use:

Fire ten rounds of SAAMI Reference Ammunition following the procedures as shown in this Standard. The average velocity and pressure results of the test should be within the Inclusion Limits as given on the latest assessment of the lot fired.

In the case of a new barrel, the firing of more breaking-in shots may be indicated after which the Reference Ammunition test should be repeated.

In the case of barrels which have been in service, refurbishing of the piston and piston hole, removal of fouling, or other corrective procedures may be implemented followed by a retest.

VELOCITY & PRESSURE BARRELS: MOUNTING IN RECEIVERS

It is essential that close headspace be maintained in velocity-pressure testing equipment if reliable test results are to be achieved.

In mounting test barrels to Universal Receivers or test actions, a headspace not exceeding 0.003” (0.07 mm) over minimum should be maintained. This may be measured by headspace gauges, shim stock or feeler gauges, or a combination thereof whichever is most appropriate for the type of equipment being used.

Headspace adjustments with the Universal Receiver may be accomplished by several methods:

1. Formed shim stock behind the firing-pin plate.
2. Formed shim stock on the rear bearing shoulder of the Barrel Collar.
3. Adjustment of the Breech Block Locking Screws.

**PROCEDURE:
USE OF PISTON HOLE GAUGES**

Pressure barrel piston hole size should be checked periodically with piston hole gauges to determine whether or not erosion is present. Piston hole erosion can cause high or erratic pressure readings and low velocity readings.

Three piston hole gauges for each piston hole size (0.146” diameter, 0.206” diameter) constitute a set: 1) plug gauge, 2) longitudinal gauge and, 3) transverse gauge. Each gauge is double-sided, “go” and “no go”. The gauges are used as described below:

1. Attempt to insert the appropriate “no go” plug gauge into the top of the piston hole.
2. Insert the appropriate “no go” longitudinal gauge through the chamber, align it with the bottom of the piston hole, and attempt to insert the gauge upward into the hole.
3. Attempt to insert the appropriate “no go” transverse gauge into the bottom of the piston hole in the same manner as described above for the longitudinal gauge.
4. If the piston hole accepts any of the “no go” gauges, the hole diameter is larger than the maximum acceptable.

The probable cause of extreme piston hole erosion is poor gas sealing (improper use of gas checks and/or insufficient oiling).

In some cases, minor erosion does not seem to affect pressure and velocity readings. An analysis of test results will indicate whether or not repair is necessary.

PROCEDURE: PIEZOELECTRIC TRANSDUCER CALIBRATION

I. SCOPE

- A. This procedure covers the calibration of piezoelectric pressure transducers (“transducers”) for use in the measurement of ballistic pressures.

II. TEST EQUIPMENT

A.	<u>ITEM</u>	<u>TYPE</u>	<u>ALTERNATE</u>
1.	Digital Voltmeter	Fluke, Model 8440	or equivalent
2.	Charge Amplifier	PCB, Model 443B02	or equivalent
3.	Transducer Calibrator (Direct fluidic calibrator)	PCB Group; The Modal Shop, Inc., Model K9905D	or equivalent
4.	Insulation Tester	Kistler, Model 5491	or equivalent
5.	Transducer	PCB, Model 117BXXX	or equivalent
6.	Low Noise Cable	PCB, Model 003CXX	or equivalent
7.	Calibration Adapter	PCB, Model 090B Series	or equivalent

III. EQUIPMENT PREPARATION

- A. All instruments should be operational and calibrated per manufacturer specification.
- B. The transducer calibrator and instruments used to calibrate the charge amplifier and digital voltmeter should have a certified calibration traceable to the National Institute of Standards and Technology.
- C. Transducers should be properly maintained per manufacturer recommendations or stored in a desiccator when not in use.



CAUTION: When not in use, the cable, transducers, and instrument connectors should be stored with plastic caps to prevent contamination.

- D. Measure the internal resistance of the transducer and low noise cable. If the resistance is less than 10^{12} ohms, follow the steps detailed in paragraph IV(B), *Transducer Initialization*. If the resistance is in the 10^{12} to 10^{14} ohm range, proceed to paragraph V, *Transducer Calibration*.

IV. TRANSDUCER INITIALIZATION

- A. Clean transducer and low noise cable connectors using an acceptable solvent per the manufacturer’s recommendations.
- B. Bake-out transducer and low noise cable in a temperature controlled oven for 24 to 48 hours at 250°F (121°C).
- C. Allow oven to return to ambient temperature at a slow rate.
- D. After removing the transducer and cable from the oven, check the internal resistance of the transducer. The resistance should be in the 10^{12} to 10^{14} ohm range.
- E. Place protective caps on transducer and cable connectors to prevent contamination.

V. TRANSDUCER CALIBRATION

A. INITIAL SET-UP

1. Turn on the electronic equipment and allow it to stabilize as recommended by the manufacturer.
2. Inspect the transducer mounting cavity to assure that the seal seat is free of dirt and any other foreign matter.
3. Mount transducer with steel spacer rings into calibration fixture as described in PCB Operating Instructions Manual.
4. Loosen, but do not remove, the slotted clamp.
5. Thread the transducer into the mounting port. Adjust the slotted clamp to allow guide pin to enter guide hole. Continue to turn transducer nut into the mounting port. When transducer bottoms, tighten the slotted clamp and torque the transducer as recommended by the manufacturer.
6. It is essential that the sensing surface of the transducer be flush with the chamber inside diameter. Care must be exercised to obtain correct depth as well as exact rotational alignment. Depth adjustment is accomplished by the use of various thickness spacers. In order to set the depth exactly it may be necessary to hone the spacers to the desired thickness.
7. Mount calibration adapter with transducer on the calibrator.
8. Insert the cartridge case with an inert or fired primer into calibration adapter and complete fixture assembly as per PCB instruction manual. If the sample cartridge is a loaded round, it may be disassembled, the powder removed, and the primer in the empty case then fired. An optional procedure is to deprime the case and use the O-ring/plug seal shown in Section III – page 228. Cycle this case to the appropriate maximum pressure in order to “seat” the transducer.
9. Connect transducer and instrumentation as indicated in Figure 2 on page 175.
10. Set the charge amplifier sensitivity to 0.999 and set the time constant switch to LONG.
11. Set DVM to 10-volt range.

B. CALIBRATION

1. Adjust pressure readout indicator of the transducer calibrator to 0 psi with no pressure on hydraulic lines.
2. Insert a new cartridge case.
3. Reset charge amplifier and digital voltmeter (DVM) to obtain zero volts output.
4. Apply pressure in increments as indicated in Section II – pages 170-174. Calibration pressure range should cover the pressure ranges shown in Section II – pages 170-174. DO NOT exceed the maximum pressure established by the manufacturer for the fixture.
5. Record DVM reading after the pressure readout indicator is exactly at desired pressure level. Do not release the pressure until the highest pressure level, for the cartridge under test, has been reached. Read the pressure at each increment. Do not overshoot the pressure points!
6. After reaching the highest calibration pressure level, release the pressure slowly.
7. Replace the cartridge case in calibration adapter.
8. Repeat steps 1 through 7 until a minimum of ten valid data points are obtained.



CAUTION: Always INCREASE pressure to desired level, never decrease pressure to desired level.

9. Transducers need to be re-calibrated when changing brands of ammunition or if there have been changes in cartridge case processes and/or material.

C. DATA REDUCTION

1. Calculate the average value for the output voltages recorded at each pressure increment. Multiply these average values by the charge amplifier sensitivity (pC/V) to obtain the transducer charge output (Q) at these pressure increments (P).
2. Obtain a least square line equation using the transducer charge output (Q) as the dependent variable and pressure (P) as the independent variable. $Q = mP \pm q$.
3. A manual method of calculating the least square line equation is given in tabular form in Section II – page 176. It is recommended that when using this technique, all numbers be carried to the third decimal place.
4. Obtain the pressure (P) offset value when Q in the line equation is zero. Refer to Figure 4, page 177.

VI. CALIBRATION CHECK

- A. When the calibration calculations are complete, the sensitivity should be set on the charge amplifier. The digital voltmeter is set at zero. A new sample cartridge case is put in the calibration fixture and the hydraulic pressure increased to the highest pressure reached in the calibration. The digital voltmeter reading plus the offset should equal the hydraulic gauge reading. Check calibration again by inserting a second cartridge case. As a guideline, these values should agree within $\pm 1.5\%$ of the gauge reading. If the transducer does not meet this guideline then recheck the calculations and/or recalibrate.

VII. TRANSDUCER RECORDS

- A. Date of calibration
- B. The number of rounds to which the transducer has been exposed during test firing.
- C. Calibration pressure (P), charge amplifier voltage output (V), and transducer charge output (Q).
- D. Charge amplifier sensitivity.
- E. Least square line equation.
- F. Pressure offset, and transducer sensitivity (slope = m).
- G. Transducer identification.
- H. Date of next calibration.

**TRANSDUCER CALIBRATION:
 INCREMENTS AND RANGES**

The following increments and ranges are to be used for the calibration of transducers:

Cartridge	MAP (psi/100)	Pressure Increments (psi)	Pressure Range (psi)
6 x 45mm	550	5,000	35,000 – 60,000
6mm Remington	650	5,000	35,000 – 60,000
6.5 Creedmoor	620	5,000	35,000 – 60,000
6.5 Grendel	520	5,000	35,000 – 60,000
6.5x55 Swedish	510	5,000	35,000 – 60,000
6.8mm Remington SPC	550	5,000	35,000 – 60,000
7mm Mauser (7x57)	510	5,000	35,000 – 60,000
7mm Remington Magnum	610	5,000	35,000 – 60,000
7mm Remington Short Action Ultra Magnum	650	5,000	35,000 – 60,000
7mm Remington Ultra Magnum	650	5,000	35,000 – 60,000
7mm Shooting Times Westerner	650	5,000	35,000 – 60,000
7mm Weatherby Magnum	650	5,000	35,000 – 60,000
7mm Winchester Short Magnum	650	5,000	35,000 – 60,000
7mm-08 Remington	610	5,000	35,000 – 60,000
7 x 64 Brenneke	N/E ⁽¹⁾	N/E	N/E
7-30 Waters	450	5,000	25,000 – 50,000
7.62 x 39	450	5,000	25,000 – 50,000
8mm Mauser (8x57)	350	5,000	20,000 – 45,000
8mm Remington Magnum	650	5,000	35,000 – 60,000
9.3 x 62	575	5,000	35,000 – 60,000
17 Hornet	500	5,000	35,000 – 60,000
17 Remington	630	5,000	35,000 – 60,000
17 Remington Fireball	550	5,000	35,000 – 60,000
204 Ruger	575	5,000	35,000 – 60,000
218 Bee	N/E	N/E	N/E

¹ N/E = Not Established.

**TRANSDUCER CALIBRATION:
 INCREMENTS AND RANGES
 (Continued)**

Cartridge	MAP (psi/100)	Pressure Increments (psi)	Pressure Range (psi)
22 Hornet	490	5,000	35,000 – 60,000
22-250 Remington	650	5,000	35,000 – 60,000
220 Swift	620	5,000	35,000 – 60,000
221 Remington Fireball	N/E ⁽¹⁾	N/E	N/E
222 Remington	500	5,000	35,000 – 60,000
222 Remington Magnum	550	5,000	35,000 – 60,000
223 Remington	550	5,000	35,000 – 60,000
223 Winchester Super Short Magnum	650	5,000	35,000 – 60,000
225 Winchester	N/E	N/E	N/E
243 Winchester	600	5,000	35,000 – 60,000
243 Winchester Super Short Magnum	650	5,000	35,000 – 60,000
25 Winchester Super Short Magnum	650	5,000	35,000 – 60,000
25-06 Remington	630	5,000	35,000 – 60,000
25-20 Winchester	N/E	N/E	N/E
25-35 Winchester	N/E	N/E	N/E
250 Savage	N/E	N/E	N/E
257 Roberts	540	5,000	35,000 – 60,000
257 Roberts +P	580	5,000	35,000 – 60,000
257 Weatherby Magnum	625	5,000	35,000 – 60,000
26 Nosler	650	5,000	35,000 – 60,000
260 Remington	600	5,000	35,000 – 60,000
264 Winchester Magnum	640	5,000	35,000 – 60,000
27 Nosler	650	5,000	35,000 – 60,000
270 Weatherby Magnum	625	5,000	35,000 – 60,000
270 Winchester	650	5,000	35,000 – 60,000
270 Winchester Short Magnum	650	5,000	35,000 – 60,000
28 Nosler	650	5,000	35,000 – 60,000
280 Ackley Improved	650	5,000	35,000 – 60,000
280 Remington	600	5,000	35,000 – 60,000
284 Winchester	560	5,000	35,000 – 60,000

¹ N/E = Not Established.

**TRANSDUCER CALIBRATION:
 INCREMENTS AND RANGES
 (Continued)**

Cartridge	MAP (psi/100)	Pressure Increments (psi)	Pressure Range (psi)
30 Carbine	400	5,000	20,000 – 45,000
30 Nosler	650	5,000	35,000 – 60,000
30 Remington AR	550	5,000	35,000 – 60,000
30 Thompson Center	620	5,000	35,000 – 60,000
30-06 Springfield	600	5,000	35,000 – 60,000
30-30 Winchester	420	5,000	25,000 – 50,000
30-40 Krag	N/E ⁽¹⁾	N/E	N/E
300 AAC Blackout	550	5,000	35,000 – 60,000
300 Holland & Holland Magnum	580	5,000	35,000 – 60,000
300 Remington Short Action Ultra Magnum	650	5,000	35,000 – 60,000
300 Remington Ultra Magnum	650	5,000	35,000 – 60,000
300 Ruger Compact Magnum	650	5,000	35,000 – 60,000
300 Savage	470	5,000	30,000 – 55,000
300 Weatherby Magnum	650	5,000	35,000 – 60,000
300 Winchester Magnum	640	5,000	35,000 – 60,000
300 Winchester Short Magnum	650	5,000	35,000 – 60,000
303 British	490	5,000	35,000 – 60,000
307 Winchester	N/E	N/E	N/E
308 Marlin Express	475	5,000	30,000 – 55,000
308 Winchester	620	5,000	35,000 – 60,000
32 Winchester Special	420	5,000	25,000 – 50,000
32-20 Winchester	N/E	N/E	N/E
325 Winchester Short Magnum	650	5,000	35,000 – 60,000
33 Nosler	650	5,000	35,000 – 60,000
338 Federal	620	5,000	35,000 – 60,000
338 Lapua Magnum	650	5,000	35,000 – 60,000
338 Marlin Express	460	5,000	30,000 – 55,000
338 Remington Ultra Magnum	650	5,000	35,000 – 60,000
338 Ruger Compact Magnum	650	5,000	35,000 – 60,000
338 Winchester Magnum	640	5,000	35,000 – 60,000

¹ N/E = Not Established.

**TRANSDUCER CALIBRATION:
 INCREMENTS AND RANGES
 (Continued)**

Cartridge	MAP (psi/100)	Pressure Increments (psi)	Pressure Range (psi)
340 Weatherby Magnum	625	5,000	35,000 – 60,000
348 Winchester	N/E ⁽¹⁾	N/E	N/E
35 Nosler	650	5,000	35,000 – 60,000
35 Remington	335	5,000	20,000 – 45,000
35 Whelen	620	5,000	35,000 – 60,000
350 Remington Magnum	N/E	N/E	N/E
356 Winchester	N/E	N/E	N/E
358 Winchester	N/E	N/E	N/E
36 Nosler	650	5,000	35,000 – 60,000
370 Sako Magnum	600	5,000	35,000 – 60,000
375 Holland & Holland Magnum	620	5,000	35,000 – 60,000
375 Remington Ultra Magnum	650	5,000	35,000 – 60,000
375 Ruger	620	5,000	35,000 – 60,000
375 Winchester	N/E	N/E	N/E
376 Steyr	620	5,000	35,000 – 60,000
38-40 Winchester	N/E	N/E	N/E
38-55 Winchester	N/E	N/E	N/E
405 Winchester	460	5,000	30,000 – 55,000
416 Remington Magnum	650	5,000	35,000 – 60,000
416 Rigby	520	5,000	35,000 – 60,000
416 Ruger	620	5,000	35,000 – 60,000
416 Weatherby Magnum	N/E	N/E	N/E
44 Remington Magnum	360	5,000	20,000 – 45,000
44-40 Winchester	110	2,000	10,000 – 18,000
444 Marlin	420	5,000	25,000 – 50,000

¹ N/E = Not Established.

**TRANSDUCER CALIBRATION:
INCREMENTS AND RANGES
(Continued)**

Cartridge	MAP (psi/100)	Pressure Increments (psi)	Pressure Range (psi)
45-70 Government	280	5,000	15,000 – 40,000
450 Bushmaster	385	5,000	20,000 – 45,000
450 Marlin	435	5,000	25,000 – 50,000
457 Wild West Guns	435	5,000	25,000 – 50,000
458 Lott	625	5,000	35,000 – 60,000
458 Winchester Magnum	600	5,000	35,000 – 60,000
470 Nitro Express	410	5,000	25,000 – 50,000
475 Turnbull	420	5,000	25,000 – 50,000
500 Nitro Express 3”	385	5,000	20,000 – 45,000

**TRANSDUCER CALIBRATION:
EQUIPMENT INTERCONNECTION**

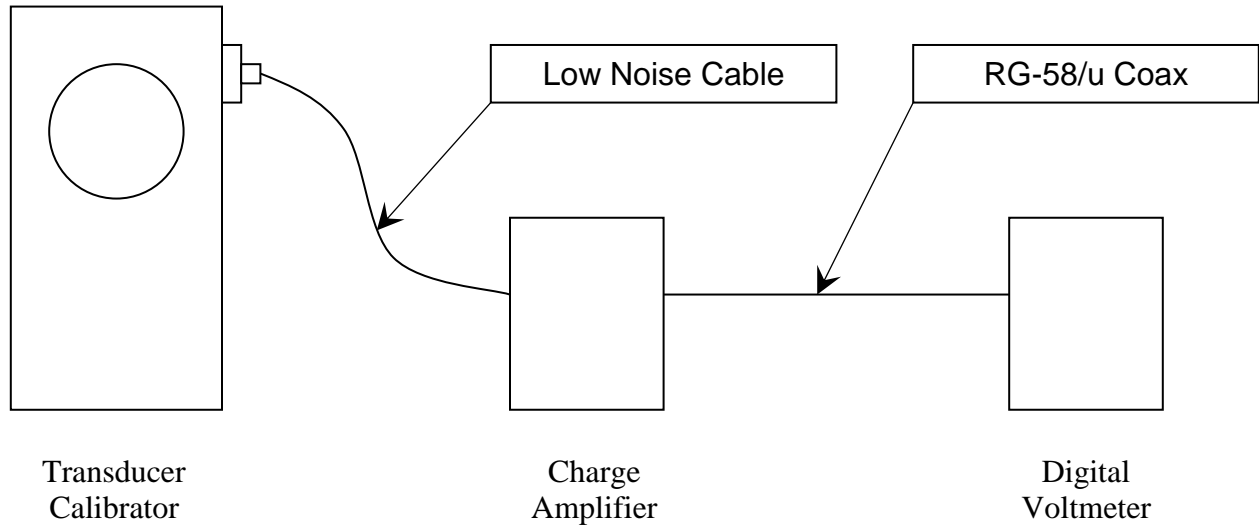

Figure 2

**TRANSDUCER CALIBRATION:
 LEAST SQUARE LINE COMPUTATION**

$$Q = mP + q$$

$$m = \frac{\sum(PQ) - \frac{\sum P \sum Q}{n}}{\sum P^2 - \frac{(\sum P)^2}{n}} \quad q = \frac{\sum P \sum(PQ) - \sum(P^2) \sum Q}{(\sum P)^2 - n \sum P^2}$$

Where:

n = Number of data points.

Q = Charge, in picocoulombs, pC.

m = Slope ($\Delta Q/\Delta P$); transducer sensitivity in pC/psi.

P = Pressure, in pounds per square inch, psi.

q = Charge intercept, in picocoulombs, pC.

V = Average output voltage at the indicated pressure, in volts, v.

S = Charge amplifier sensitivity.

$$Offset = \frac{q}{m}$$

	P	S	V	Q (SV)	(PQ)	P ²
TOTAL	$\Sigma P =$			$\Sigma Q =$	$\Sigma(PQ) =$	$\Sigma(P^2) =$

Figure 3

OUTPUT vs. PRESSURE

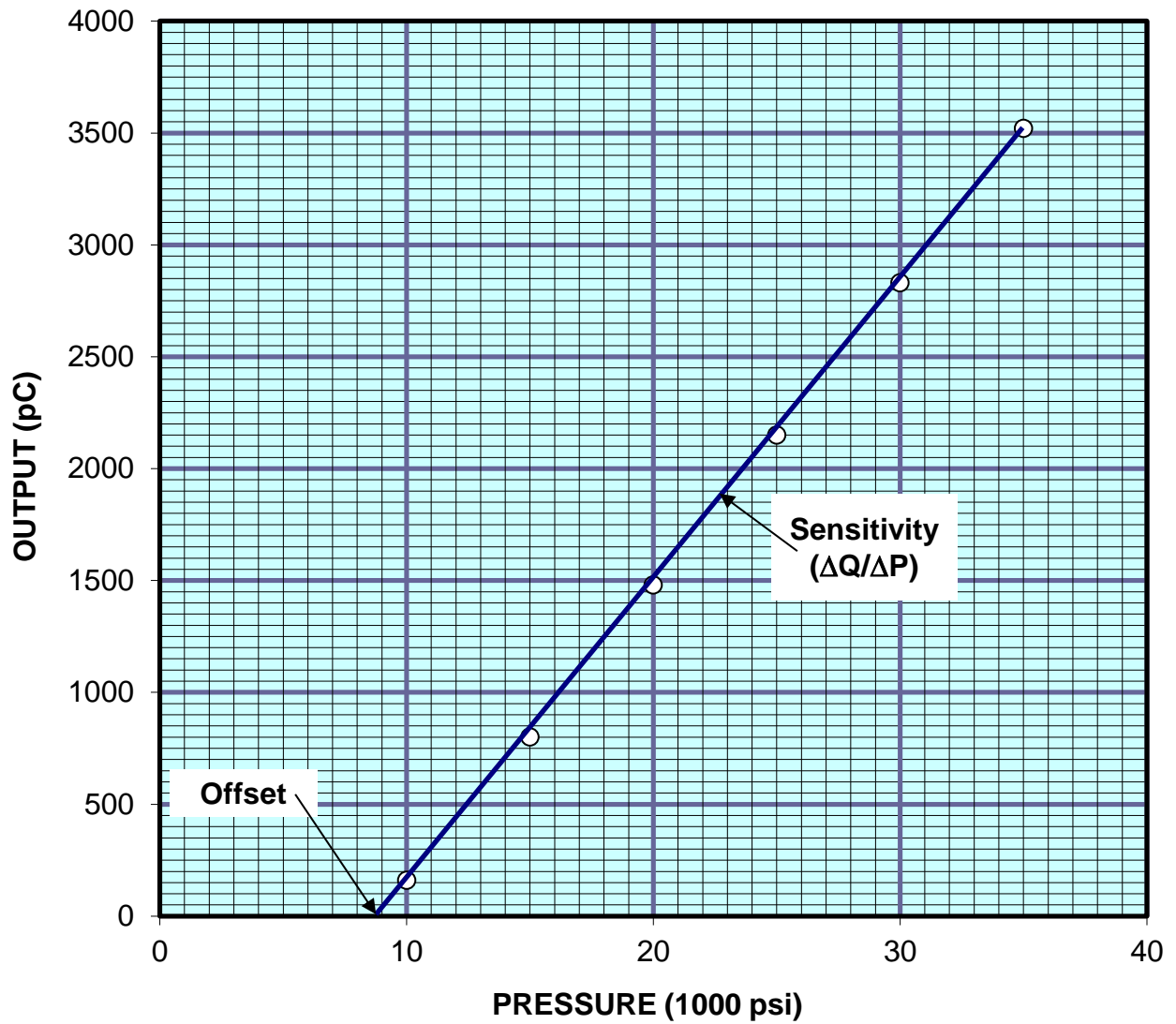

Figure 4

**FIRING TEST:
EQUIPMENT INTERCONNECTION**

Configuration 1

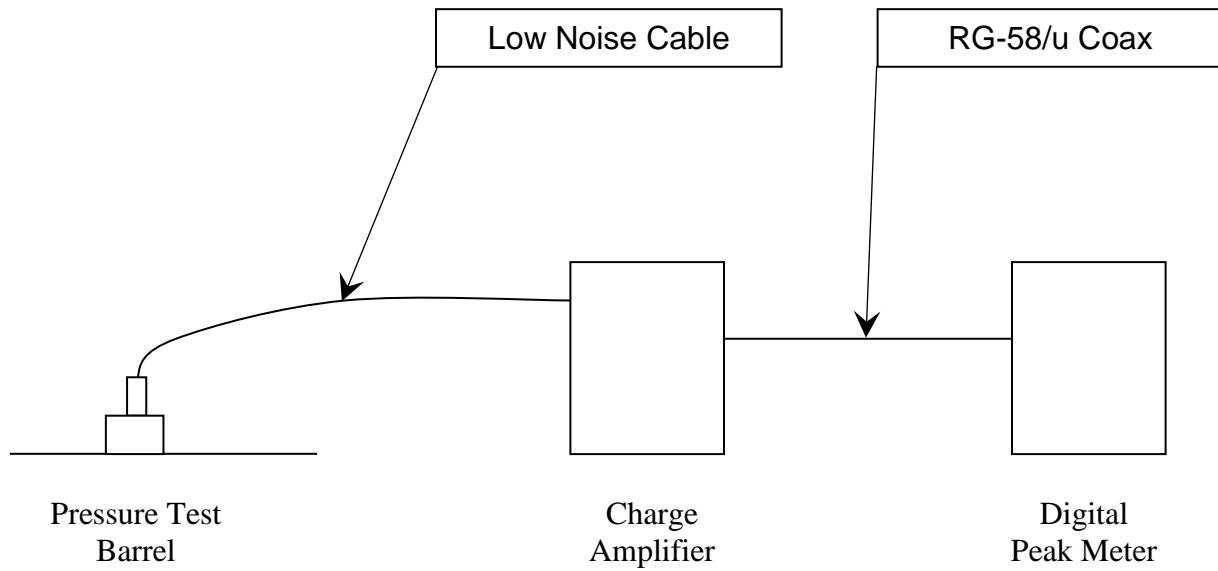

Figure 5

FIRING TEST:
EQUIPMENT INTERCONNECTION (cont'd)

Configuration 2

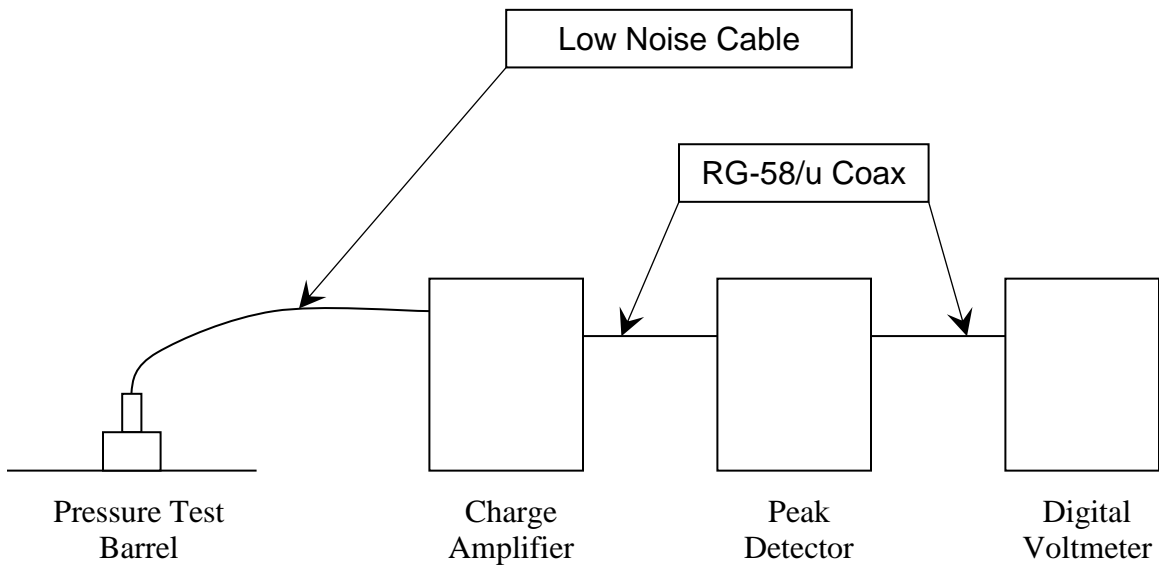

Figure 6

REFERENCE AMMUNITION: USE

A. PURPOSE

Reference Ammunition is for the purpose of relating pressure and velocity test results at all ranges.

B. PROCUREMENT

Reference Ammunition is procured as noted in Section III – page 221.

C. USE

The use and usefulness of Reference Ammunition in connection with the testing of ammunition for velocity and pressure is predicated upon two basic assumptions as follows:

1. Associated with a given batch of Reference Ammunition at a given time is an assessed average velocity, an assessed average pressure, as well as upper and lower limits for each, which the averages of any ten round test may be expected to fall within when:
 - a. The reference ammunition manufacturer has applied appropriate safeguards to assure homogeneity of the lot.
 - b. The ammunition is tested only after being conditioned under controlled temperature and humidity.
 - c. The ammunition is tested in equipment compliant with Section III recommendations.
 - d. The ammunition is handled in strict accordance with Section II recommendations.
 - e. All auxiliary measuring equipment has been set up in accordance with Section II recommendations and is in proper working condition.
2. Although there will be changes over time in the velocity and pressure assessments, the changes occur sufficiently slowly to be detected by periodic reassessments before they have achieved a magnitude sufficient to impair the usefulness of the reference rounds. In other words, the velocity and pressure assessments are reasonably stable with time.

The average velocity and pressure that may be developed by a sample of Reference Ammunition in any given standard test barrel under given test conditions may be different from the results obtained under the test conditions referred to above in assumption 1 due to minor equipment variations and statistical sampling error. Such values may be perfectly real, providing the auxiliary equipment introduces no errors.

In order to realize the benefits of Reference Ammunition, some rules must be adhered to. Nevertheless, each individual user must make the final judgments concerning how often it is used and the use of the data. It is important, therefore, that there be a clear realization of what it can and what it cannot tell the ammunition tester.

Reference Ammunition cannot guarantee the absolute accuracy of any test system. It does, however, provide simple and direct data from any given ammunition test equipment to determine how closely it relates to the acceptable, average system as used by SAAMI members.

In line with the preceding discussion, the following recommendations are made for the use of Reference ammunition:

- A. Each Reference Lot should be conditioned before use.
- B. How often Reference Ammunition is used shall be determined by the user's internal practices, taking into account such factors as historical knowledge of barrel life.
- C. The recommended minimum sample shall be ten rounds.
- D. In the event the observed average velocity and pressure of the sample falls within the *Inclusion Limits*, a correction may or may not be applied according to the procedure given in Step G at the discretion of the user.
- E. If one average is outside of the *Inclusion Limits* and the other within, the average that exceeds the limits shall be corrected according to the procedure given in Step G.
- F. If both averages are outside of the *Inclusion Limits*, both the velocity and pressure shall be corrected according to the procedure in Step G.
- G. If the correction is to be applied, the correction shall be the difference between the assessed value and the observed average of the test.

**REFERENCE AMMUNITION:
SECONDARY REFERENCE AMMUNITION**

Occasionally, a test station will have a need for an inordinately large supply of Reference Ammunition in considerable excess to the usual volume. In order to minimize the premature exhaustion of any particular lot, it is suggested that the station create its own secondary reference lot to fill the special need.

A secondary reference lot should consist of a supply of off-the-shelf ammunition, each box bearing the same manufacturer's code name. The secondary reference lot should be approximately equivalent in bullet weight, average velocity, and average pressure to the Reference Ammunition that it replaces.

REFERENCE AMMUNITION: NEW LOTS

I. GENERAL

Reference Ammunition lots have been established for those lots or loads designated by the Technical Committee. Responsibility for production of each of the selected lots is assigned to a member company that is responsible for maintaining a supply. A five-year supply is recommended. It is desirable that Reference Ammunition be consistent with Standard values for that particular round.

When a producer has prepared a new lot, it shall be his responsibility to announce the lot to the SAAMI Technical Office⁶, giving a tentative assessment and other data. (An example of the recommended format for this announcement appears later in this section.)

The producer shall supply, at the time of the announcement of the new lot, to each member of the Reference Ammunition Group that has the capability to test that cartridge, one box of the new lot for immediate test. A current list of the testing capabilities of the Reference Ammunition Group is available from the SAAMI Technical Office on request.

The SAAMI Technical Office will announce the availability of the new lot to the participating ranges, giving the tentative assessment and other pertinent data. (An example of the recommended format for this announcement appears later in this section.)

II. METHOD OF ASSESSMENT

Before announcing a new lot of reference ammunition to the SAAMI Technical Office, the manufacturer should make sufficient tests to determine Tentative Values of pressure and velocity for the new lot.

1. The test barrels shall conform to the SAAMI specifications for internal dimensions, length and piston / piezo gauge location. (Refer to Section III.)
2. Counter-chronographs and photoelectric screens shall be used in velocity measurements. (See Section III.)
3. Ammunition shall be conditioned for a minimum of 24 hours at $70^{\circ} \pm 2^{\circ}\text{F}$ ($21.1^{\circ} \pm 1.1^{\circ}\text{C}$) with relative humidity of $60\% \pm 5\%$ before firing.
4. For copper crusher assessments, only an approved crusher lot shall be used in pressure measurements. (See Section III – page 195 for proper crusher sizes.)

⁶ Refer to Section III - pages 223, for current contact information for the SAAMI Technical Office.

NEW REFERENCE LOT REPORTING FORM AND INSTRUCTIONS

These instructions pertain to the form shown in Section II, which is used for a Reference Ammunition producer to announce new lots to the SAAMI Technical Office, as well as for the SAAMI Technical Office to announce the new lot to participating ranges.

SUBJECT: T-4010 Reference Ammunition – Centerfire Rifle
New Reference Lot

TO: *When used by a producer:*
SAAMI Technical Office⁷

When used by SAAMI Technical Office to notify test stations:
Current address of all stations and personnel.

(1) Name and address of source
for procurement as shown
in Section III

SIGNED: Authorized Person
Producer Company Name
Address (including zip
code)

DATE:

⁷ Refer to Section III - page 223 for current contact information for the SAAMI Technical Office.

ANNOUNCEMENT OF NEW REFERENCE AMMUNITION LOT

SUBJECT: T-4010 Reference Ammunition – Centerfire Rifle
New Reference Lot

TO:

CARTRIDGE _____ Lot No. _____
Order Symbol _____

- TENTATIVE ASSESSMENT -

* CRUSHER *			
VELOCITY (ft/s)		PRESSURE (CUP in units of 100)	
(LONG Piston)		(SHORT Piston)	
AVERAGE:	σ :	AVERAGE:	σ :
* TRANSDUCER *			
VELOCITY (ft/s)		PRESSURE (psi in units of 100)	
AVERAGE:	σ :	AVERAGE:	σ :
		OFFSET:	

Lot number this lot replaces: _____

Please test the ammunition and report the results to the SAAMI Technical Office on the proper form (CFR Section II) as soon as possible.

SIGNED:

DATE:

REFERENCE AMMUNITION: IDENTIFICATION PROTOCOL

SAAMI Reference Ammunition

This ammunition is to be used only for calibration
of test gauges for velocity and pressure.

LOT NUMBERING SYSTEM (Typical numbers)

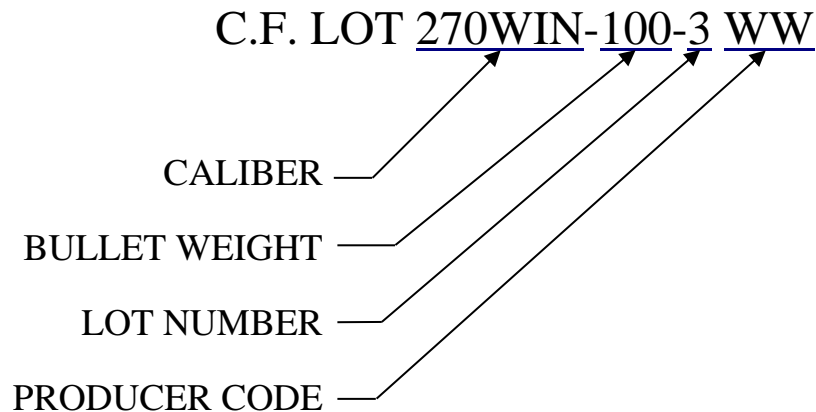

PRODUCER CODES

- A = A-Square OBSOLETE*
- B = Blount (Alliant Ammunition & Accessories; CCI/Speer) OBSOLETE*
- BB = Barnes Bullets
- CS = CCI/Speer
- F = Federal Cartridge Co.
- H = Hornady Manufacturing
- N = Nosler
- R = Remington Arms Company, LLC
- WW = Winchester Division, Olin Corporation

NOTE

BLACK LETTERING

REFERENCE AMMUNITION: PERIODIC ASSESSMENT

I. PROCUREMENT

Reference ammunition is procured as noted in Section III.

II. PERIODIC TESTS

A. STATIONS

1. All test conditions should conform as closely as possible to those prescribed in this Standard, and the following conditions should be met:
 - a) Tests should consist of ten (10) rounds for velocity and pressure fired during a single day.
 - b) Test barrels shall conform to SAAMI specifications for internal dimensions, length, and piston/transducer location.
 - c) Counter-chronographs and photoelectric screens (or equivalents) shall be used in velocity measurements. (See Section III.)
 - d) Ammunition shall be conditioned for 72 hours at $70^{\circ} \pm 2^{\circ}\text{F}$ ($21.1^{\circ} \pm 1.1^{\circ}\text{C}$) with relative humidity of $60\% \pm 5\%$ before firing.
 - e) Only an approved crusher lot and/or transducer shall be used in pressure measurements. (See Section III, page 195 for proper crusher sizes.)
2. Each station should report results of its firing in the test on approved forms to the SAAMI Technical Office¹. A sample of this report form is presented later in this subsection.

B. CLEARING HOUSE

1. The SAAMI Technical Office serves as the clearinghouse for all Reference Ammunition ballistics and related information. It shall be the responsibility of the SAAMI Technical Office to schedule testing and to assemble and distribute results of periodic tests. This should be done on the proper Reference Ammunition report form. (Sample, Section II)
2. The Reference Ammunition Report shall contain the average pressure, velocity, and related standard deviations as reported by each station for that lot. From this data, the SAAMI Technical Office will calculate and report the Raw Average, Corrected Average, and Inclusion Limits.
3. To obtain the Raw Averages, the SAAMI Technical Office shall include the 10-round averages for the pressure and velocity of all reporting stations and the first and second previous assessment value. If the 10-round average from any station

¹ Refer to Section III – page 223 for current contact information for the SAAMI Technical Office.

varies from the Raw Average by more than plus or minus 50 fps in velocity OR plus or minus 3,500 CUP/psi in pressure, the pressure or velocity data from that (those) station(s) should be discarded. The mean pressure and velocity data should be recalculated omitting the discarded data. The new mean is the “Corrected Average”. If the mean pressure value of a station is outside of the limits as defined above, but the velocity is in, the pressure data should be dropped and the velocity data retained. The converse is true as well. Using the Corrected Averages, the Inclusion Limits are determined as follows:

VELOCITY: MEAN = Same as Corrected Average

HIGH = MEAN + 50 fps

LOW = MEAN – 50 fps

PRESSURE: MEAN = Same as Corrected Average

HIGH = MEAN + 3,500 CUP/psi

LOW = MEAN – 3,500 CUP/psi

T-4010 STATION REPORT
 REFERENCE AMMUNITION – PERIODIC ASSESSMENT
 CENTERFIRE RIFLE

STATION _____

SAAMI REFERENCE LOT _____

DATE _____

PREVIOUS ASSESSMENT

Velocity _____

Pressure Barrel No. _____

Pressure _____

Rounds to-date _____

Velocity Barrel No. _____

Type of Gauge _____

Rounds to-date _____

No. _____

	VELOCITY	PRESSURE
1.		
2.		
3.		
4.		
5.		
6.		
7.		
8.		
9.		
10.		
AVERAGE		
OFFSET		
FINAL AVERAGE.		
$\sigma_{(n-1)}$		

TECHNICAL SERVICES REPORT – REFERENCE AMMUNITION

PERIODIC ASSESSMENT – CF Rifle

MAY – 2015

LOT NO: 30CARB-110-5WW

GAUGE: CRUSHER

	<u>VELOCITY</u>	σ	<u>PRESSURE</u>	σ
CCI/Speer	2,036	15.0	372	11.8
Federal	1,983	21.0	334	9.4
Hodgdon	2,015	5.0	412	17.2
Hornady Manufacturing	2,044	11.0	365	13.5
New River Energetics	2,004	14.0	328	10.0
Nosler	2,020	12.5	378	11.7
Remington – Lonoke	2,014	22.0	371	10.1
St. Marks Powder	2,046	10.0	370	28.0
Winchester	1,975	8.6	3337	17..9

1 st Previous Average	2,016		356	
2 nd Previous Average	2,013		350	

	<u>VELOCITY</u>	σ	<u>PRESSURE</u>	σ
Raw Average	2,015		361	
Corrected Average	2,015		356	
Inclusion Limits @ 99.95%				
Upper Limit	2,065		391	
Lower Limit	1,965		321	

ASSESSMENT 2,015 356

EQUIPMENT: VELOCITY & COPPER CRUSHER PRESSURE TESTING

NOTE: Refer to Section III – page 223, *Supplier Contact Information*, for detailed information on contacting the manufacturers of listed products and the SAAMI Technical Office.

1. Electronic Counter Chronograph – 100 kilohertz, minimum
 - a) Oehler Research
 - b) Electronic Counters, Inc.
 - c) Other equivalent.
2. Table of velocity vs. time of flight or electronic calculator.

NOTE: Items (1) and (2) may be replaced by a direct-reading velocity chronograph or integrated ballistic instrumentation system with equivalent accuracy and precision.
3. Photoelectric screens
 - a) Oehler Research
 - b) Electronic Counters, Inc.
 - c) Other equivalent.
4. Universal Receiver
 - a) Ulysses Machine Company
 - b) H-S Precision, Inc.
 - c) Other equivalent.
5. Test Barrel (Drawings of test barrels are presented in Section III).
 - a) H-S Precision, Inc.
 - b) Wiseman
 - c) Wilson Arms Company
 - d) Hart Rifle Barrels, Inc.
 - e) Krieger Barrels, Inc.
 - f) Or equivalent.
6. Piston (Section III)
7. Piston and piston hole gauges (Section III)
8. Oil, SAE 30
9. Gas check (Section III)
10. Gas check tools – seating and knockout (Section III)
11. Copper crushers
 - 0.146” x 0.400”
 - 0.225” x 0.400”Manufactured (Section III)
Winchester Division, Olin Corporation.
12. Tarage table (supplied with each lot of purchased crushers; see Section III, pages 196-197 for sample tables)

0.146" x 0.400" when used with 0.146" piston
0.146" x 0.400" when used with 0.206" piston
0.225" x 0.400" when used with 0.206" piston

13. Measuring device for compressed crushers

- a) Micrometer, 1" capacity, minimum, 0.0005" precision.
- b) Platform dial indicator, 1" capacity, minimum, 0.0005" precision.
- c) Other device capable of measuring lengths up to 0.500" with a minimum precision of 0.0005"

14. Reference ammunition. (Refer to Section III – page 221 for supply sources.)

**EQUIPMENT:
VELOCITY & CONFORMAL PIEZOELECTRIC PRESSURE TESTING**

NOTE: Refer to Section III – page 223, *Supplier Contact Information*, for detailed information on contacting the manufacturers of listed products and the SAAMI Technical Office.

1. Electronic Counter Chronograph – 100 kilohertz, minimum
 - a) Oehler Research
 - b) Electronic Counters, Inc
 - c) Other equivalent.
2. Table of velocity vs. time of flight or electronic calculator.

NOTE: Items (1) and (2) may be replaced by a direct-reading velocity chronograph or integrated ballistic instrumentation system with equivalent accuracy and precision.
3. Photoelectric screens
 - a) Oehler Research
 - b) Electronic Counters, Inc.
 - c) Other equivalent.
4. Universal Receiver
 - a) Ulysses Machine Company
 - b) H-S Precision, Inc.
 - c) Other equivalent.
5. Test Barrel (Drawings of test barrels are presented in Section III).
 - a) H-S Precision, Inc.
 - b) Wiseman
 - c) Wilson Arms Company
 - d) Hart Rifle Barrels, Inc.
 - e) Krieger Barrels, Inc.
 - f) Or equivalent.
6. Digital voltmeter
 - a) Fluke model 8440
 - b) Other equivalent
7. Charge amplifier with 20KHz low pass filter
 - a) PCB Piezotronics, Inc. model 443B02
 - b) Other equivalent
8. Peak meter
 - a) PCB Piezotronics, Inc. model 444A152
 - b) Other equivalent

NOTE: Items (6) and (8) or (6), (7), and (8) may be replaced by an integrated ballistic instrumentation system of equivalent accuracy and precision.

9. Piezoelectric transducer
 - a) PCB Piezotronics, Inc. model 117Bxx
 - b) Other equivalent
10. Low noise cable
 - a) PCB Piezotronics, Inc. model 003Cxx
 - b) Other equivalent
11. Transducer calibrator
 - a) PCB Group; The Modal Shop, Inc.; Model K9905D
 - b) Other equivalent
12. Calibration adapter
 - a) PCB Piezotronics, Inc. model 090B series
 - b) Other equivalent
13. Reference ammunition
Refer to Section III – page 221 for supply sources.

USAGE OF CRUSHER CYLINDERS IN PRESSURE TESTING

Copper crusher cylinders manufactured and qualified in accordance with SAAMI guidelines and of the nominal sizes listed below shall be used for pressure tests of centerfire rifle cartridges.

Crusher cylinders shall not be pre-compressed before use.

Sample tarage tables are shown on pages 196 and 197 for illustrative purposes; only the tarage table furnished with the particular lot of cylinders should be used.

Designation	Nominal Size	PISTON		Average Pressure Limits (CUP/100)
		Diameter	Area	
A	0.146" x 0.400"	0.206"	1/30 inch ²	Less than 240
C	0.225" x 0.400"	0.206"	1/30 inch ²	240 and greater

It is recommended that pressures be recorded in "Copper Units of Pressure", or "CUP".*

* - The designation "Copper Units of Pressure" ("CUP") was adopted by the Technical Committee at their meeting of January 8, 1969, to replace the previous designation of "pounds per square inch." Advances in the art of pressure-sensing devices had shown that pressures recorded by deformation of copper crusher cylinders are not necessarily a true measure of pounds per square inch for the transient phenomena encountered in sporting arms ammunition.

SAMPLE TARAGE TABLE
 COPPER CRUSHER CYLINDERS
 0.146" DIAMETER, 0.400" LONG
 FOR USE WITH 0.206" DIAMETER PISTON
 AREA = 1/30 SQUARE INCH

*CUP in units of 100

<u>Final Length</u>	<u>Pressure CUP*</u>	<u>Final Length</u>	<u>Pressure CUP*</u>	<u>Final Length</u>	<u>Pressure CUP*</u>	<u>Final Length</u>	<u>Pressure CUP*</u>
0.3995	14	0.3795	102	0.3595	155	0.3395	219
0.3990	20	0.3790	103	0.3590	156	0.3390	221
0.3985	25	0.3785	105	0.3585	157	0.3385	223
0.3980	30	0.3780	106	0.3580	158	0.3380	225
0.3975	33	0.3775	108	0.3575	159	0.3375	227
0.3970	35	0.3770	109	0.3570	160	0.3370	229
0.3965	38	0.3765	111	0.3565	161	0.3365	231
0.3960	41	0.3760	112	0.3560	162	0.3360	233
0.3955	44	0.3755	114	0.3555	163	0.3355	235
0.3950	46	0.3750	115	0.3550	164	0.3350	237
0.3945	49	0.3745	117	0.3545	165	0.3345	239
0.3940	51	0.3740	118	0.3540	166	0.3340	241
0.3935	53	0.3735	120	0.3535	167	0.3335	243
0.3930	55	0.3730	121	0.3530	168	0.3330	245
0.3925	57	0.3725	122	0.3525	169	0.3325	247
0.3920	59	0.3720	123	0.3520	170	0.3320	249
0.3915	61	0.3715	125	0.3515	172	0.3315	251
0.3910	63	0.3710	126	0.3510	173	0.3310	253
0.3905	65	0.3705	127	0.3505	174	0.3305	255
0.3900	67	0.3700	128	0.3500	175	0.3300	257
0.3895	69	0.3695	130	0.3495	177	0.3295	259
0.3890	70	0.3690	131	0.3490	179	0.3290	261
0.3885	72	0.3685	133	0.3485	181	0.3285	263
0.3880	73	0.3680	134	0.3480	183	0.3280	265
0.3875	75	0.3675	136	0.3475	185	0.3275	267
0.3870	76	0.3670	137	0.3470	187	0.3270	269
0.3865	78	0.3665	138	0.3465	189	0.3265	271
0.3860	80	0.3660	139	0.3460	192	0.3260	273
0.3855	82	0.3655	141	0.3455	194	0.3255	275
0.3850	83	0.3650	142	0.3450	196	0.3250	277
0.3845	85	0.3645	143	0.3445	198	0.3245	279
0.3840	87	0.3640	144	0.3440	200	0.3240	281
0.3835	89	0.3635	146	0.3435	202	0.3235	283
0.3830	91	0.3630	147	0.3430	204	0.3230	285
0.3825	93	0.3625	148	0.3425	206	0.3225	287
0.3820	94	0.3620	149	0.3420	209	0.3220	289
0.3815	96	0.3615	150	0.3415	211	0.3215	291
0.3810	97	0.3610	151	0.3410	213	0.3210	293
0.3805	99	0.3605	153	0.3405	215	0.3205	295
0.3800	100	0.3600	154	0.3400	217	0.3200	297

NOTE: Tarage tables are established for each lot of cylinders. Only the table furnished by the manufacturer with each shipment of cylinders should be used.

SAMPLE TARAGE TABLE
 COPPER CRUSHER CYLINDERS
 0.225" DIAMETER, 0.400" LONG
 FOR USE WITH 0.206" DIAMETER PISTON
 AREA = 1/30 SQUARE INCH

*CUP in units of 100

<u>Final Length</u>	<u>Pressure CUP*</u>	<u>Final Length</u>	<u>Pressure CUP*</u>	<u>Final Length</u>	<u>Pressure CUP*</u>	<u>Final Length</u>	<u>Pressure CUP*</u>
0.399	30	0.359	383	0.319	590	0.279	783
0.398	60	0.358	390	0.318	595	0.278	787
0.397	78	0.357	395	0.317	600	0.277	792
0.396	96	0.356	400	0.316	605	0.276	797
0.395	106	0.355	405	0.315	610	0.275	802
0.394	117	0.354	411	0.314	614	0.274	807
0.393	127	0.353	416	0.313	619	0.273	812
0.392	138	0.352	421	0.312	623	0.272	816
0.391	150	0.351	427	0.311	628	0.271	821
0.390	158	0.350	433	0.310	633	0.270	826
0.389	167	0.349	438	0.309	637	0.269	831
0.388	175	0.348	444	0.308	642	0.268	836
0.387	184	0.347	450	0.307	647	0.267	840
0.386	193	0.346	455	0.306	651	0.266	845
0.385	202	0.345	460	0.305	656	0.265	850
0.384	211	0.344	466	0.304	661	0.264	855
0.383	219	0.343	471	0.303	666	0.263	860
0.382	226	0.342	477	0.302	670	0.262	864
0.381	234	0.341	483	0.301	675	0.261	869
0.380	241	0.340	488	0.300	680	0.260	874
0.379	248	0.339	493	0.299	685	0.259	879
0.378	255	0.338	497	0.298	690	0.258	884
0.377	263	0.337	502	0.297	695	0.257	888
0.376	270	0.336	507	0.296	700	0.256	893
0.375	277	0.335	511	0.295	705	0.255	898
0.374	284	0.334	516	0.294	710	0.254	903
0.373	290	0.333	521	0.293	715	0.253	908
0.372	297	0.332	526	0.292	720	0.252	913
0.371	304	0.331	531	0.291	725	0.251	917
0.370	311	0.330	535	0.290	729	0.250	922
0.369	318	0.329	540	0.289	734		
0.368	325	0.328	545	0.288	739		
0.367	332	0.327	550	0.287	744		
0.366	339	0.326	555	0.286	749		
0.365	345	0.325	560	0.285	754		
0.364	351	0.324	565	0.284	759		
0.363	358	0.323	570	0.283	764		
0.362	364	0.322	575	0.282	768		
0.361	370	0.321	580	0.281	773		
0.360	376	0.320	585	0.280	778		

NOTE: Tarage tables are established for each lot of cylinders. Only the table furnished by the manufacturer with each shipment of cylinders should be used.

**CRUSHER CYLINDERS:
DIMENSIONS – 0.146” x 0.400”**

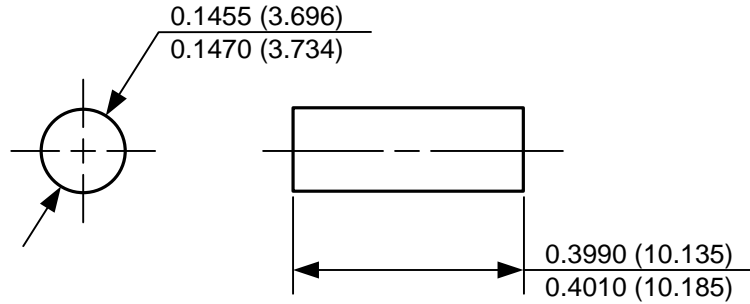

NOTES:

1. Material: Copper Development Association Alloy 102
2. (XX.XX) = Millimeters

**CRUSHER CYLINDERS:
DIMENSIONS – 0.225” x 0.400”**

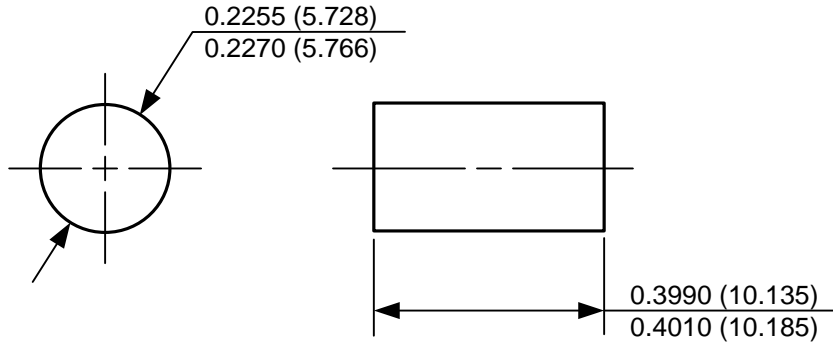

NOTES:

1. Material: Copper Development Association Alloy 102
2. (XX.XX) = Millimeters

**EQUIPMENT:
0.206" GAS CHECKS**

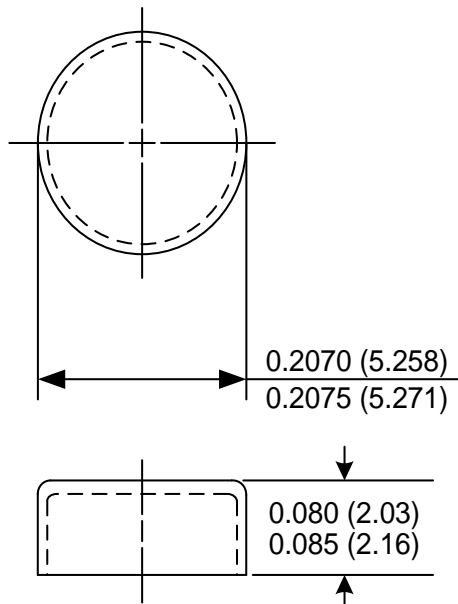

0.206" Gas Check
Material thickness
0.0110 – 0.0115 (0.279 – 0.292)

NOTES

1. Material – Copper Development Association Alloy 210
Grain size – 0.015 – 0.030mm
2. (X.XXX) = Millimeters

**EQUIPMENT:
 PISTONS AND PISTON HOLES**

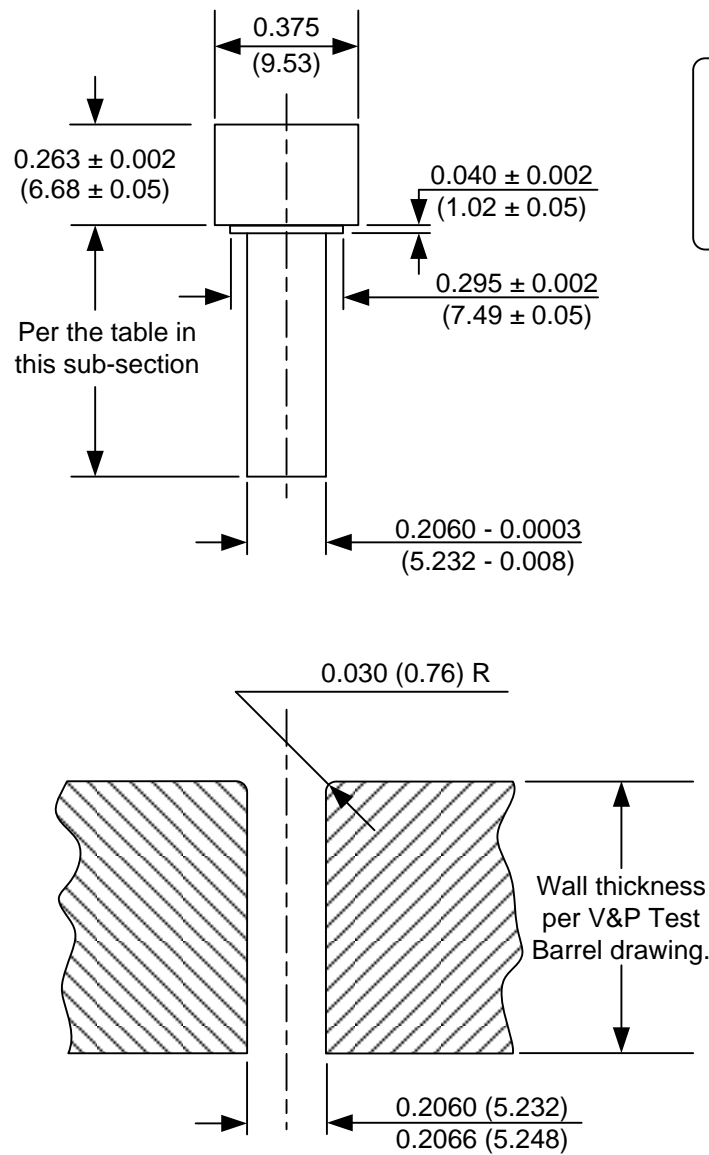

**SHORT PISTON

 PRESSURE
 TESTING**

NOTES:

1. Material – High carbon steel – heat treat R_c 62-63
2. Pistons to be suction fit in piston holes.
3. (XX.XX) = Millimeters.

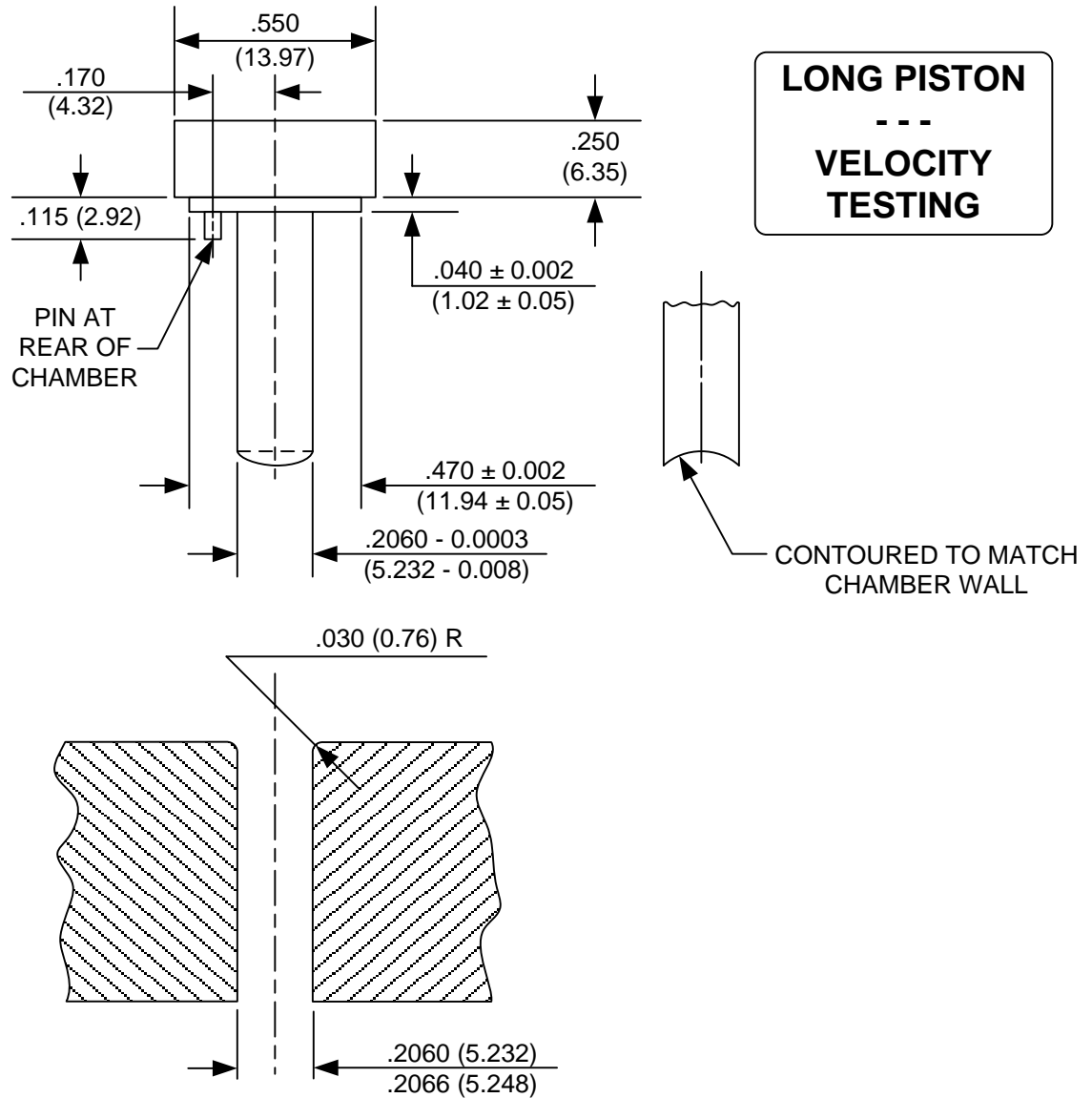

NOTES:

4. Material – High carbon steel – heat treat R_c 62-63
5. Pistons to be suction fit in piston holes.
6. (XX.XX) = Millimeters.

Due to the variation in the distance from the chamber wall to the outside edge of the test barrel caused by variation in cartridge diameters, “short” (pressure measurement) pistons for different cartridges are required to be different lengths. This table presents the appropriate short piston lengths for test barrels made in accordance with the drawings and other requirements in Section III.

Cartridge	Piston Diameter		Piston Length Recommendation	
	Inches	mm	Inches	mm
6x45mm	N/E			
6mm Remington	0.206	5.23	0.624	15.84
6.5 Creedmoor	N/E ¹			
6.5 Grendel	N/E			
6.5 x 55 Swedish	0.206	5.23	0.621	15.77
6.8mm Remington SPC	N/E			
7mm Mauser (7x57)	0.206	5.23	0.624	15.84
7mm Remington Magnum	0.206	5.23	0.602	15.29
7mm Remington Short Action Ultra Magnum	N/E			
7mm Remington Ultra Magnum	N/E			
7mm Shooting Times Westerner	0.206	5.23	0.605	15.36
7mm Weatherby Magnum	N/E			
7mm Winchester Short Magnum	N/E			
7mm-08 Remington	0.206	5.23	0.619	15.72
7 x 64 Brenneke	0.206	5.23	0.625	15.88
7-30 Waters	0.206	5.23	0.645	16.38
7.62 x 39	0.206	5.23	0.638	16.21
8mm Mauser (8x57)	0.206	5.23	0.623	15.83
8mm Remington Magnum	0.206	5.23	0.602	15.29
9.3 x 62	N/E			
17 Hornet	N/E			
17 Remington	0.206	5.23	0.666	16.92
17 Remington Fireball	N/E			

¹ N/E = Not Established

Cartridge	Piston Diameter		Piston Length Recommendation	
	Inches	mm	Inches	mm
204 Ruger	N/E ¹			
218 Bee	0.206	5.23	0.681	17.30
22 Hornet	0.206	5.23	0.708	17.98
22-250 Remington	0.206	5.23	0.630	16.01
220 Swift	0.206	5.23	0.637	16.19
221 Remington Fireball	0.206	5.23	0.666	16.91
222 Remington	0.206	5.23	0.666	16.92
222 Remington Magnum	0.206	5.23	0.666	16.91
223 Remington	0.206	5.23	0.666	16.90
223 Winchester Super Short Magnum	N/E			
225 Winchester	0.206	5.23	0.643	16.33
243 Winchester	0.206	5.23	0.619	15.72
243 Winchester Super Short Magnum	N/E			
25 Winchester Super Short Magnum	N/E			
25-06 Remington	0.206	5.23	0.621	15.77
25-20 Winchester	0.206	5.23	0.681	17.29
25-35 Winchester	0.206	5.23	0.658	16.70
250 Savage	0.206	5.23	0.630	16.00
257 Roberts	0.206	5.23	0.624	15.84
257 Roberts +P	0.206	5.23	0.624	15.84
257 Weatherby Magnum	0.206	5.23	0.601	15.26
26 Nosler	N/E			
260 Remington	N/E			
264 Winchester Magnum	0.206	5.23	0.602	15.29
27 Nosler	N/E			
270 Weatherby Magnum	0.206	5.23	0.601	15.26
270 Winchester	0.206	5.23	0.621	15.77
270 Winchester Short Magnum	N/E			
28 Nosler	N/E			
280 Ackley Improved	N/E			
280 Remington	0.206	5.23	0.621	15.76
284 Winchester	0.206	5.23	0.606	15.38

¹ N/E = Not established.

Cartridge	Piston Diameter		Piston Length Recommendation	
	Inches	mm	Inches	mm
30 Carbine	0.206	5.23	0.676	17.16
30 Nosler	N/E ¹			
30 Remington AR	N/E			
30 Thompson Center	N/E			
30-06 Springfield	0.206	5.23	0.621	15.77
30-30 Winchester	0.206	5.23	0.645	16.38
30-40 Krag	0.206	5.23	0.630	16.00
300 AAC Blackout	N/E			
300 Holland & Holland Magnum	0.206	5.23	0.605	15.37
300 Remington Short Action Ultra Magnum	N/E			
300 Remington Ultra Magnum	N/E			
300 Ruger Compact Magnum	N/E			
300 Savage	0.206	5.23	0.621	15.77
300 Weatherby Magnum	0.206	5.23	0.600	15.23
300 Winchester Magnum	0.206	5.23	0.602	15.29
300 Winchester Short Magnum	N/E			
303 British	0.206	5.23	0.633	16.09
307 Winchester	0.206	5.23	0.619	15.72
308 Marlin Express	N/E			
308 Winchester	0.206	5.23	0.619	15.72
32 Winchester Special	0.206	5.23	0.645	16.38
32-20 Winchester	0.206	5.23	0.677	17.20
325 Winchester Short Magnum	N/E			

¹ N/E = Not established.

Cartridge	Piston Diameter		Piston Length Recommendation	
	Inches	mm	Inches	mm
33 Nosler	N/E ¹			
338 Federal	N/E			
338 Lapua Magnum	N/E			
338 Marlin Express	N/E			
338 Remington Ultra Magnum	N/E			
338 Ruger Compact Magnum	N/E			
338 Winchester Magnum	0.206	5.23	0.602	15.29
340 Weatherby Magnum	0.206	5.23	0.600	15.23
348 Winchester	0.206	5.23	0.597	15.15
35 Nosler	N/E			
35 Remington	0.206	5.23	0.629	15.98
35 Whelen	0.206	5.23	0.621	15.77
350 Remington Magnum	0.206	5.23	0.601	15.27
356 Winchester	0.206	5.23	0.619	15.72
358 Winchester	0.206	5.23	0.619	15.72
36 Nosler	N/E			
370 Sako Magnum	N/E			
375 Holland & Holland Magnum	0.206	5.23	0.604	15.33
375 Remington Ultra Magnum	N/E			
375 Ruger	N/E			
375 Winchester	0.206	5.23	0.644	16.36
376 Steyr	N/E			
38-40 Winchester	0.206	5.23	0.620	15.75
38-55 Winchester	0.206	5.23	0.645	16.39

¹ N/E = Not established.

Cartridge	Piston Diameter		Piston Length Recommendation	
	Inches	mm	Inches	mm
405 Winchester	N/E ¹			
416 Remington Magnum	0.206	5.23	0.602	15.29
416 Rigby	N/E			
416 Ruger	N/E			
416 Weatherby Magnum	0.206	5.23	0.565	14.35
44 Remington Magnum	0.206	5.23	0.621	15.78
44-40 Winchester	0.206	5.23	0.619	15.73
444 Marlin	0.206	5.23	0.618	15.70
45-70 Government	0.206	5.23	0.602	15.29
450 Bushmaster	N/E			
450 Marlin	N/E			
457 Wild West Guns	N/E			
458 Lott	N/E			
458 Winchester Magnum	0.206	5.23	0.603	15.31
470 Nitro Express	0.206	5.23	0.578	14.68
475 Turnbull	N/E			
500 Nitro Express 3”	N/E			

¹ N/E = Not Established

**EQUIPMENT:
 PISTON HOLE GAUGES**

PLUG GAUGE

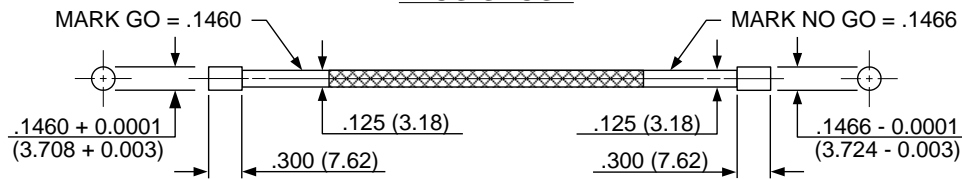

LONGITUDINAL GAUGE

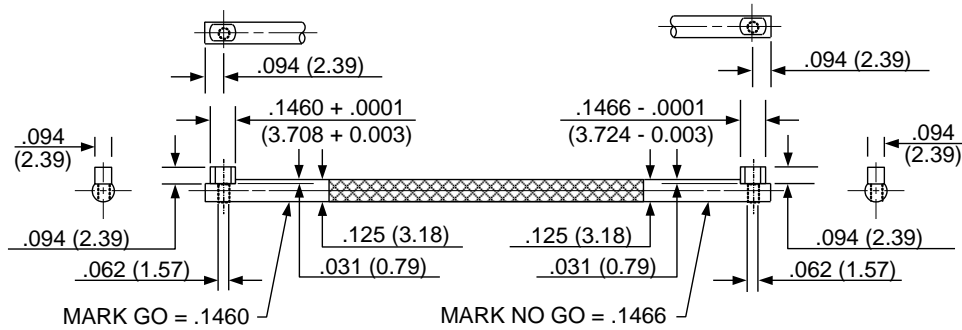

TRANSVERSE GAUGE

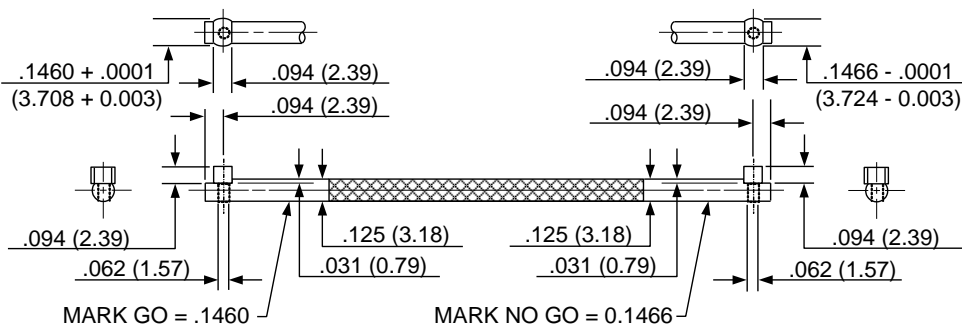

NOTES:

1. General tolerance $\pm .005$ (0.13)
2. Material – Oil hard drill rod AISI -O1 R_c 61-63
3. (XX.XX) = Millimeters

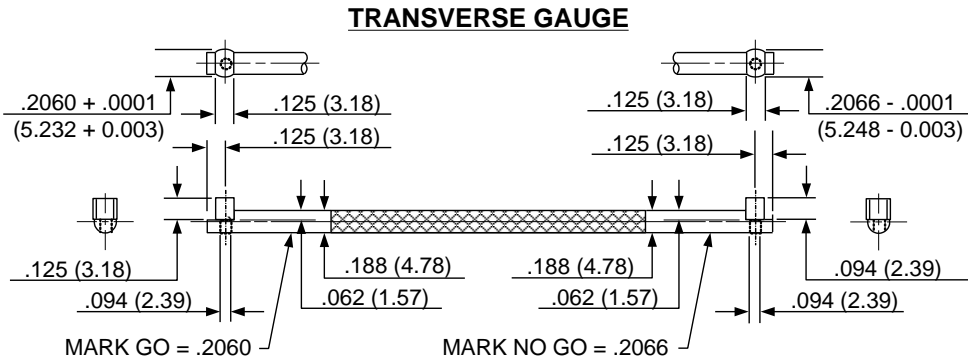
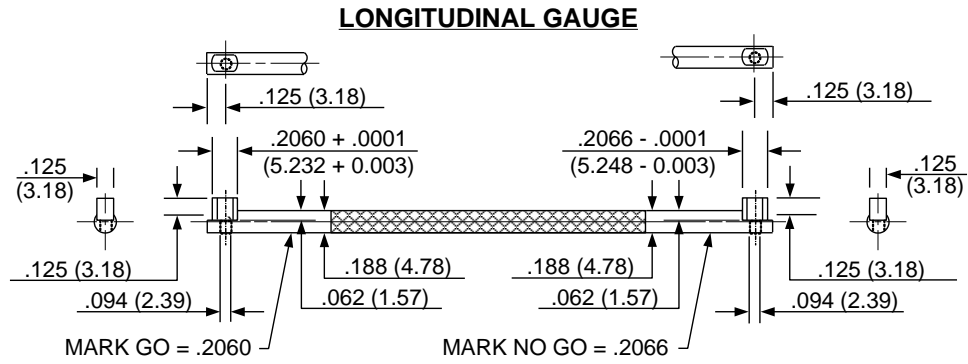
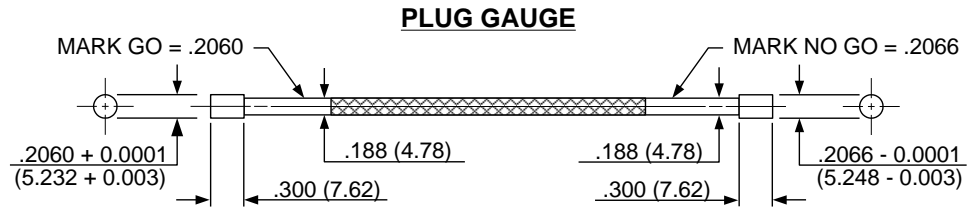

NOTES:

1. General tolerance $\pm .005$ (0.13)
2. Material – Oil hard drill rod AISI -O1 R_c 61-63
3. (XX.XX) = Millimeters

PISTON OIL – PISTON AND GAS CHECK

It is recommended that pistons and gas checks (other than those filled with gas check wax) be lubricated with the following oil:

SAE 30 or equivalent

Viscosity at 210°F (98.9°C)

58 Saybolt seconds universal, minimum

70 Saybolt seconds universal, maximum

The oil should be of non-detergent type.

HEADSPACE GAUGES

GAUGES FOR SHOULDER-BREECHING CARTRIDGES

FIGURE I
 SHOULDER-BREECHING CENTERFIRE RIFLE HEADSPACE GAUGES

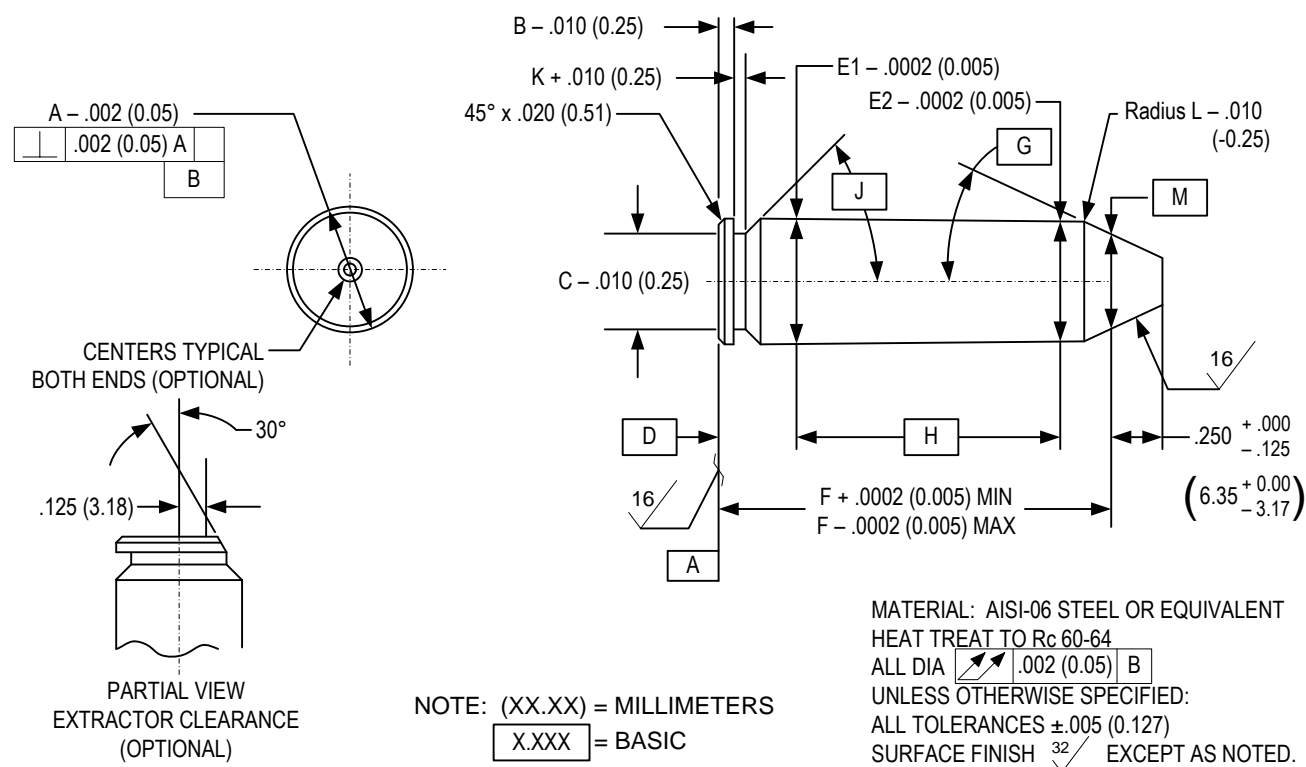

CARTRIDGE NAME	A	B	C	BASIC D	E1	E2	F		G	BASIC H		J	K	L	BASIC M
							MIN	MAX							
6 x 45mm	0.378 (9.60)	0.045 (1.14)	0.332 (8.43)	0.2000 (5.080)	0.3749 (9.522)	0.3574 (9.078)	1.4636 (37.175)	1.4736 (37.429)	23°	1.0000 (25.400)	25°	0.030 (0.76)	0.035 (0.89)	0.330 (8.38)	
6mm Remington	0.473 (12.01)	0.049 (1.24)	0.408 (10.36)	0.2000 (5.080)	0.4704 (11.948)	0.4308 (10.942)	1.7767 (45.128)	1.7867 (45.382)	26°	1.4750 (37.465)	31°	0.037 (0.94)	0.035 (0.89)	0.3750 (9.525)	
6.5 Creedmoor	0.473 (12.01)	0.054 (1.37)	0.409 (10.39)	0.2000 (5.080)	0.4694 (11.923)	0.4619 (11.732)	1.5410 (39.141)	1.5510 (39.395)	30°	1.150 (29.21)	36°	0.055 (1.40)	0.040 (1.02)	0.400 (10.16)	
6.5 Grendel															
6.5 x 55 Swedish	0.479 (12.17)	0.051 (1.30)	0.413 (10.49)	0.2000 (5.080)	0.4762 (12.095)	0.4357 (11.067)	1.7794 (45.197)	1.7894 (45.451)	25°	1.4500 (36.830)	45°	0.029 (0.74)	0.124 (3.15)	0.3650 (9.271)	
6.8mm Remington SPC	0.422 (10.72)	0.049 (1.24)	0.358 (9.09)	0.2000 (5.080)	0.4200 (10.668)	0.4025 (10.224)	1.3460 (34.188)	1.3560 (34.442)	23°	1.0000 (25.400)	33°	0.042 (1.07)	0.040 (1.02)	0.3600 (9.144)	

I. GAUGES FOR SHOULDER-BREECHING CARTRIDGES (Cont'd)

CARTRIDGE NAME	A	B	C	BASIC D	E1	E2	F		BASIC			K	L	BASIC M
							MIN	MAX	G	H	J			
7mm Mauser (7x57)	0.473	0.049	0.409	0.2000	0.4703	0.4313	1.7947	1.8047	20°39'	1.4500	29°	0.033	0.040	0.3750
	(12.01)	(1.24)	(10.39)	(5.080)	(11.946)	(10.955)	(45.585)	(45.839)		(36.830)		(0.84)	(1.02)	(9.525)
7mm Remington Short Action Ultra Magnum	0.534	0.050	0.475	0.2000	0.5490	0.5347	1.5990	1.6090	30°	1.2500	29°	0.037	0.040	0.4600
	(13.56)	(1.27)	(12.07)	(5.080)	(13.945)	(13.581)	(40.615)	(40.869)		(31.750)		(0.94)	(1.02)	(11.684)
7mm Remington Ultra Magnum	0.543	0.050	0.475	0.2000	0.5490	0.5290	2.4742	2.4842	30°	1.7500	29°	0.037	0.040	0.4200
	(13.79)	(1.27)	(12.07)	(5.080)	(13.945)	(13.437)	(62.845)	(63.099)		(44.450)		(0.94)	(1.02)	(10.668)
7mm Winchester Short Magnum	0.535	0.054	0.480	0.2000	0.5543	0.5393	1.7640	1.7740	35°	1.3000	42°	0.040	0.060	0.4450
	(13.59)	(1.37)	(12.19)	(5.080)	(14.079)	(13.698)	(44.806)	(45.060)		(33.020)		(1.02)	(1.52)	(11.303)
7mm-08 Remington	0.473	0.054	0.409	0.2000	0.4694	0.4544	1.6300	1.6400	20°	1.2500	33°	0.055	0.040	0.4000
	(12.01)	(1.37)	(10.39)	(5.080)	(11.923)	(11.542)	(41.402)	(41.656)		(31.750)		(1.40)	(1.02)	(10.160)
7 x 64 Brenneke	0.470	0.051	0.413	0.2000	0.4641	0.4282	2.0957	2.1057	20°15'	1.6500	33°	0.039	0.030	0.3750
	(11.94)	(1.30)	(10.49)	(5.080)	(11.788)	(10.876)	(53.231)	(53.485)		(41.910)		(0.99)	(0.76)	(9.525)
7.62 x 39	0.447	0.057	0.376	0.2000	0.4438	0.4005	1.2520	1.2620	17°30'	0.9083	45°	0.047	0.040	0.3622
	(11.35)	(1.45)	(9.55)	(5.080)	(11.273)	(10.173)	(31.801)	(32.055)		(23.071)		(1.19)	(1.02)	(9.200)
8mm Mauser (8x57)	0.473	0.049	0.409	0.2000	0.4690	0.4341	1.8743	1.8843	19°	1.5000	32°	0.033	0.040	0.3920
	(12.01)	(1.24)	(10.39)	(5.080)	(11.913)	(11.026)	(47.607)	(47.861)		(38.100)		(0.84)	(1.02)	(9.957)
9.3 x 62														
17 Remington	0.378	0.045	0.332	0.2000	0.3749	0.3574	1.3785	1.3885	23°	1.0000	22°	0.030	0.035	0.3300
	(9.60)	(1.14)	(8.43)	(5.080)	(9.522)	(9.078)	(35.014)	(35.268)		(25.400)		(0.76)	(0.89)	(8.382)
17 Remington Fireball														
204 Ruger	0.378	0.045	0.332	0.2000	0.3748	0.3604	1.5613	1.5713	30°	1.2000	22°	0.030	0.035	0.3300
	(9.60)	(1.14)	(8.43)	(5.080)	(9.520)	(9.154)	(39.657)	(39.911)		(30.480)		(0.76)	(0.89)	(8.382)
22-250 Remington	0.473	0.049	0.409	0.2000	0.4661	0.4164	1.5749	1.5849	28°	1.2400	31°	0.033	0.035	0.3470
	(12.01)	(1.24)	(10.39)	(5.080)	(11.839)	(10.577)	(40.002)	(40.256)		(31.496)		(0.84)	(0.89)	(8.814)
220 Swift	0.473	0.049	0.426	0.2000	0.4438	0.4043	1.8060	1.8160	21°	1.4000	12°	0.025	0.040	0.3350
	(12.01)	(1.24)	(10.82)	(5.080)	(11.273)	(10.269)	(45.872)	(46.126)		(35.560)		(0.64)	(1.02)	(8.509)
221 Remington Fireball	0.3780	0.045	0.332	0.200	0.3749	0.3610	1.1038	1.1138	23°	0.800	25°	0.030	0.035	0.330
	(9.601)	(1.14)	(8.43)	(5.08)	(9.522)	(9.169)	(28.037)	(28.291)		(20.32)		(0.76)	0.89	(8.38)
222 Remington	0.378	0.045	0.332	0.2000	0.3749	0.3574	1.2936	1.3036	23°	1.0000	22°	0.025	0.035	0.3300
	(9.60)	(1.14)	(8.43)	(5.080)	(9.522)	(9.078)	(32.857)	(33.111)		(25.400)		(0.64)	(0.89)	(8.382)
222 Remington Magnum	0.378	0.045	0.378	0.2000	0.3743	0.3569	1.4925	1.5025	23°	1.2000	22°	0.030	0.035	0.3300
	(9.60)	(1.14)	(9.60)	(5.080)	(9.507)	(9.065)	(37.910)	(38.164)		(30.480)		(0.76)	(0.89)	(8.382)
223 Remington	0.378	0.045	0.332	0.2000	0.3749	0.3574	1.4636	1.4736	23°	1.0000	22°	0.030	0.035	0.3300
	(9.60)	(1.14)	(8.43)	(5.080)	(9.522)	(9.078)	(37.175)	(37.429)		(25.400)		(0.76)	(0.89)	(8.382)
223 Winchester Super Short Magnum	0.535	0.054	0.480	0.2000	0.5543	0.5454	1.2403	1.2503	28°	0.8000	42°	0.040	0.060	0.4450
	(13.59)	(1.37)	(12.19)	(5.080)	(14.079)	(13.853)	(31.504)	(31.758)		(20.320)		(1.02)	(1.52)	(11.303)
225 Winchester	0.473	0.049		0.2000	0.4213	0.4062	1.5860	1.5960	25°	1.2600			0.040	0.3500
	(12.01)	(1.24)		(5.080)	(10.701)	(10.317)	(40.284)	(40.538)		(32.004)			(1.02)	(8.890)
243 Winchester	0.473	0.054	0.409	0.2000	0.4694	0.4544	1.6300	1.6400	20°	1.2500	33°	0.055	0.040	0.4000
	(12.01)	(1.37)	(10.39)	(5.080)	(11.923)	(11.542)	(41.402)	(41.656)		(31.750)		(1.40)	(1.02)	(10.160)
243 Winchester Super Short Magnum	0.535	0.054	0.480	0.2000	0.5543	0.5454	1.2403	1.2503	28°	0.8000	42°	0.040	0.060	0.4450
	(13.59)	(1.37)	(12.19)	(5.080)	(14.079)	(13.853)	(31.504)	(31.758)		(20.320)		(1.02)	(1.52)	(11.303)
25 Winchester Super Short Magnum	0.535	0.054	0.480	0.2000	0.5543	0.5454	1.2403	1.2503	30°	0.8000	42°	0.040	0.060	0.4450
	(13.59)	(1.37)	(12.19)	(5.080)	(14.079)	(13.853)	(31.504)	(31.758)		(20.320)		(1.02)	(1.52)	(11.303)
25-06 Remington	0.473	0.049	0.409	0.2000	0.4688	0.4420	2.0487	2.0587	17°15'	1.6500	33°	0.033	0.060	0.3750
	(12.01)	(1.24)	(10.39)	(5.080)	(11.908)	(11.227)	(52.037)	(52.291)		(41.910)		(0.84)	(1.52)	(9.525)
250 Savage	0.473	0.049	0.409	0.2000	0.4677	0.4182	1.5792	1.5892	26°30'	1.2000	33°	0.033	0.110	0.3470
	(12.01)	(1.24)	(10.39)	(5.080)	(11.880)	(10.622)	(40.112)	(40.366)		(30.480)		(0.84)	(2.79)	(8.814)

I. GAUGES FOR SHOULDER-BREECHING CARTRIDGES (Cont'd)

CARTRIDGE NAME	A	B	C	BASIC D	E1	E2	F		BASIC					
							MIN	MAX	G	H	J	K	L	BASIC M
257 Roberts	0.473	0.049	0.409	0.2000	0.4702	0.4317	1.7937	1.8037	20°39'	1.4700	33°	0.033	0.040	0.3750
257 Roberts +P	(12.01)	(1.24)	(10.39)	(5.080)	(11.943)	(10.965)	(45.560)	(45.814)		(37.338)		(0.84)	(1.02)	(9.525)
26 Nosler	0.534	0.050	0.475	0.2000	0.5509	0.5309	2.2390	2.2490	35°	1.7500	32°	0.037	0.040	0.4200
	(13.56)	(1.27)	(12.07)	(5.080)	(13.993)	(13.485)	(56.871)	(57.125)		(44.450)		(0.94)	(1.02)	(10.670)
260 Remington	0.473	0.054	0.409	0.2000	0.4694	0.4544	1.6300	1.6400	20°	1.2500	33°	0.055	0.040	0.4000
	(12.01)	(1.37)	(10.39)	(5.080)	(11.923)	(11.542)	(41.402)	(41.656)		(31.750)		(1.40)	(1.02)	(10.160)
27 Nosler	0.534	0.050	0.475	0.2000	0.5509	0.5309	2.1823	2.1923	35°	1.7500	32°	0.037	0.040	0.4200
	(13.56)	(1.27)	(12.07)	(5.080)	(13.993)	(13.485)	(55.430)	(55.684)		(44.450)		(0.94)	(1.02)	(10.670)
270 Winchester	0.473	0.049	0.409	0.2000	0.4688	0.4420	2.0487	2.0587	17°15'	1.6500	33°	0.033	0.040	0.3750
	(12.01)	(1.24)	(10.39)	(5.080)	(11.908)	(11.227)	(52.037)	(52.291)		(41.910)		(0.84)	(1.02)	(9.525)
270 Winchester Short Magnum	0.535	0.054	0.480	0.2000	0.5543	0.5393	1.7260	1.7360	35°	1.3000	42°	0.040	0.060	0.4450
	(13.59)	(1.37)	(12.19)	(5.080)	(14.079)	(13.698)	(43.840)	(44.094)		(33.020)		(1.02)	(1.52)	(11.303)
28 Nosler	0.534	0.050	0.475	0.2000	0.5509	0.5309	2.2390	2.2490	35°	1.7500	32°	0.037	0.040	0.4200
	(13.56)	(1.27)	(12.07)	(5.080)	(13.993)	(13.485)	(56.871)	(57.125)		(44.450)		(0.94)	(1.02)	(10.670)
280 Ackley Improved	0.472	0.047	0.407	0.200	0.4690	0.4542	2.1400	2.1500	40°	1.750	36°	0.027	0.035	0.375
	(11.99)	(1.19)	(10.34)	(5.08)	(11.913)	(11.537)	(54.356)	(54.610)		(44.45)		(0.69)	(0.89)	(9.53)
280 Remington	0.473	0.049	0.409	0.2000	0.4694	0.4407	2.1000	2.1100	17°15'	1.7500	33°	0.033	0.035	0.3750
	(12.01)	(1.24)	(10.39)	(5.080)	(11.923)	(11.194)	(53.340)	(53.594)		(44.450)		(0.84)	(0.89)	(9.525)
284 Winchester	0.473	0.054	0.409	0.2000	0.4990	0.4766	1.8100	1.8200	35°	1.4000	37°	0.040	0.040	0.4200
	(12.01)	(1.37)	(10.39)	(5.080)	(12.675)	(12.106)	(45.974)	(46.228)		(35.560)		(1.02)	(1.02)	(10.668)
30 Nosler	0.534	0.050	0.475	0.2000	0.5509	0.5309	2.1870	2.1977	35°	1.7500	32°	0.037	0.040	0.4200
	(13.56)	(1.27)	(12.07)	(5.080)	(13.993)	(13.485)	(56.871)	(57.125)		(44.450)		(0.94)	(1.02)	(10.670)
30 Remington AR	0.492	0.054	0.428	0.200	0.4990	0.4897	1.1590	1.1690	25°	0.700	36°	0.055	0.040	0.400
	(12.50)	(1.37)	(10.87)	(5.08)	(12.675)	(12.438)	(29.439)	(29.693)		(17.78)		(1.40)	1.02	(10.16)
30 Thompson Center	0.409	0.054	0.473	0.200	0.4706	0.4640	1.5640	1.5740	30°	1.150	36°	0.055	0.040	0.400
	(10.39)	(1.37)	(12.01)	(5.08)	(11.953)	(11.786)	(39.726)	(39.980)		(29.21)		(1.40)	1.02	(10.16)
30-06 Springfield	0.473	0.049	0.409	0.2000	0.4688	0.4420	2.0487	2.0587	17°15'	1.6500	33°	0.033	0.060	0.3750
	(12.01)	(1.24)	(10.39)	(5.080)	(11.908)	(11.227)	(52.037)	(52.291)		(41.910)		(0.84)	(1.52)	(9.525)
300 AAC Blackout														
300 Remington Ultra Magnum	0.543	0.050	0.475	0.2000	0.5490	0.5290	2.4742	2.4842	30°	1.7500	29°	0.037	0.040	0.4200
	(13.79)	(1.27)	(12.07)	(5.080)	(13.945)	(13.437)	(62.845)	(63.099)		(44.450)		(0.94)	(1.02)	(10.668)
300 Remington Short Action Ultra Magnum	0.534	0.050	0.475	0.2000	0.5490	0.5347	1.5990	1.6090	30°	1.2500	29°	0.037	0.040	0.4600
	(13.56)	(1.27)	(12.07)	(5.080)	(13.945)	(13.581)	(40.615)	(40.869)		(31.750)		(0.94)	(1.02)	(11.684)
300 Ruger Compact Magnum	0.532	0.050	0.475	0.200	0.5310	0.5156	1.7217	1.7317	30°	1.300	35°	0.037	0.040	0.420
	(13.51)	(1.27)	(12.07)	(5.08)	(13.487)	(13.096)	(43.731)	(43.985)		(33.02)		(0.94)	1.02	(10.67)
300 Savage	0.473	0.049	0.409	0.2000	0.4697	0.4472	1.6017	1.6117	30°	1.2500	33°	0.033	0.040	0.3968
	(12.01)	(1.24)	(10.39)	(5.080)	(11.930)	(11.359)	(40.683)	(40.937)		(31.750)		(0.84)	(1.02)	(10.079)
300 Winchester Short Magnum	0.535	0.054	0.480	0.2000	0.5543	0.5393	1.7260	1.7360	35°	1.3000	42°	0.040	0.060	0.4450
	(13.59)	(1.37)	(12.19)	(5.080)	(14.079)	(13.698)	(43.840)	(44.094)		(33.020)		(1.02)	(1.52)	(11.303)
308 Marlin Express														
308 Winchester	0.473	0.054	0.409	0.2000	0.4694	0.4544	1.6300	1.6400	20°	1.2500	33°	0.055	0.040	0.4000
	(12.01)	(1.37)	(10.39)	(5.080)	(11.923)	(11.542)	(41.402)	(41.656)		(31.750)		(1.40)	(1.02)	(10.160)
325 Winchester Short Magnum	0.535	0.054	0.480	0.2000	0.5543	0.5393	1.7260	1.7360	35°	1.3000	42°	0.040	0.060	0.4450
	(13.59)	(1.37)	(12.19)	(5.080)	(14.079)	(13.698)	(43.840)	(44.094)		(33.020)		(1.02)	(1.52)	(11.303)
33 Nosler	0.534	0.050	0.475	0.2000	0.5509	0.5309	2.0760	2.0860	35°	1.7500	32°	0.037	0.040	0.4400
	(13.56)	(1.27)	(12.07)	(5.080)	(13.993)	(13.485)	(56.871)	(57.125)		(44.450)		(0.94)	(1.02)	(11.180)
338 Remington Ultra Magnum	0.543	0.050	0.475	0.2000	0.5490	0.5290	2.3490	2.3590	30°	1.7500	29°	0.037	0.040	0.4600
	(13.79)	(1.27)	(12.07)	(5.080)	(13.945)	(13.437)	(59.665)	(59.919)		(44.450)		(0.94)	(1.02)	(11.684)

I. GAUGES FOR SHOULDER-BREECHING CARTRIDGES (Cont'd)

CARTRIDGE NAME	A	B	C	BASIC D	E1	E2	F		G	BASIC			K	L	BASIC M
							MIN	MAX		H	J				
338 Federal	0.473	0.054	0.409	0.200	0.4694	0.4544	1.6025	1.6125	20°	1.250	36°	0.055	0.040	0.420	
	(12.01)	(1.37)	(10.39)	(5.08)	(11.923)	(11.542)	(40.704)	(40.958)		(31.75)		(1.40)	1.02	(10.67)	
338 Lapua Magnum															
338 Marlin Express	0.553	0.050	0.441	0.200	0.5053	0.4933	1.5351	1.5451	25°	1.150	36°	0.039	0.040	0.420	
	(14.05)	(1.27)	(11.20)	(5.08)	(12.835)	(12.530)	(38.992)	(39.246)		(29.21)		(0.99)	1.02	(10.67)	
338 Ruger Compact Magnum	0.532	0.050	0.475	0.200	0.5310	0.5160	1.6227	1.6327	30°	1.265	35°	0.037	0.040	0.450	
	(13.51)	(1.27)	(12.07)	(5.08)	(13.487)	(13.106)	(41.217)	(41.471)		(32.13)		(0.94)	1.02	(11.43)	
35 Nosler	0.534	0.050	0.475	0.2000	0.5509	0.5309	2.0807	2.0907	35°	1.7500	32°	0.037	0.040	0.4500	
	(13.56)	(1.27)	(12.07)	(5.080)	(13.993)	(13.485)	(52.850)	(53.104)		(44.450)		(0.94)	(1.02)	(11.430)	
35 Remington	0.460	0.050	0.400	0.2000	0.4569	0.4277	1.5581	1.5681	23°25'	1.2400	31°	0.030	0.035	0.4050	
	(11.68)	(1.27)	(10.16)	(5.080)	(11.605)	(10.864)	(39.576)	(39.830)		(31.496)		(0.76)	(0.89)	(10.287)	
35 Whelen	0.473	0.049	0.409	0.2000	0.4688	0.4420	1.9835	1.9935	17°30'	1.6500	32°	0.033	0.060	0.4150	
	(12.01)	(1.24)	(10.39)	(5.080)	(11.908)	(11.227)	(50.381)	(50.635)		(41.910)		(0.84)	(1.52)	(10.541)	
358 Winchester	0.473	0.054	0.409	0.2000	0.4694	0.4544	1.6025	1.6125	20°	1.2500	33°	0.055	0.040	0.4200	
	(12.01)	(1.37)	(10.39)	(5.080)	(11.923)	(11.542)	(40.704)	(40.958)		(31.750)		(1.40)	(1.02)	(10.668)	
36 Nosler	0.534	0.050	0.475	0.2000	0.5509	0.5309	2.1976	2.2076	35°	1.7500	32°	0.037	0.040	0.4500	
	(13.56)	(1.27)	(12.07)	(5.080)	(13.993)	(13.485)	(55.819)	(56.073)		(44.450)		(0.94)	(1.02)	(11.430)	
370 Sako Magnum															
375 Remington Ultra Magnum	0.543	0.050	0.475	0.2000	0.5490	0.5290	2.4352	2.4452	30°	1.7500	29°	0.037	0.040	0.4650	
	(13.79)	(1.27)	(12.07)	(5.080)	(13.945)	(13.437)	(61.854)	(62.108)		(44.450)		(0.94)	(1.02)	(11.811)	
375 Ruger	0.532	0.050	0.475	0.200	0.5310	0.5160	2.2191	2.2291	30°	1.750	35°	0.037	0.040	0.465	
	(13.51)	(1.27)	(12.07)	(5.08)	(13.487)	(13.106)	(56.365)	(56.619)		(44.45)		(0.94)	1.02	(11.81)	
376 Steyr	0.496	0.051	0.441	0.200	0.5053	0.4794	1.9400	1.9500	17°29'30"	1.401	43°	0.039	0.030	0.445	
	(12.60)	(1.30)	(11.20)	(5.08)	(12.834)	(12.175)	(49.276)	(49.530)		(35.59)		(0.99)	0.76	(11.31)	
416 Ruger															
416 Rigby	0.590	0.065	0.500	0.5000	0.5804	0.5468	2.3738	2.3838	44°45'30"	1.5000	45°	0.033	0.040	0.4960	
	(14.99)	(1.65)	(12.70)	(12.700)	(14.742)	(13.889)	(60.295)	(60.549)		(38.100)		(0.84)	(1.02)	(12.598)	

II. GAUGES FOR BELT-BREACHING CARTRIDGES

FIGURE II
BELT-BREACHING CENTERFIRE RIFLE HEADSPACE GAUGES

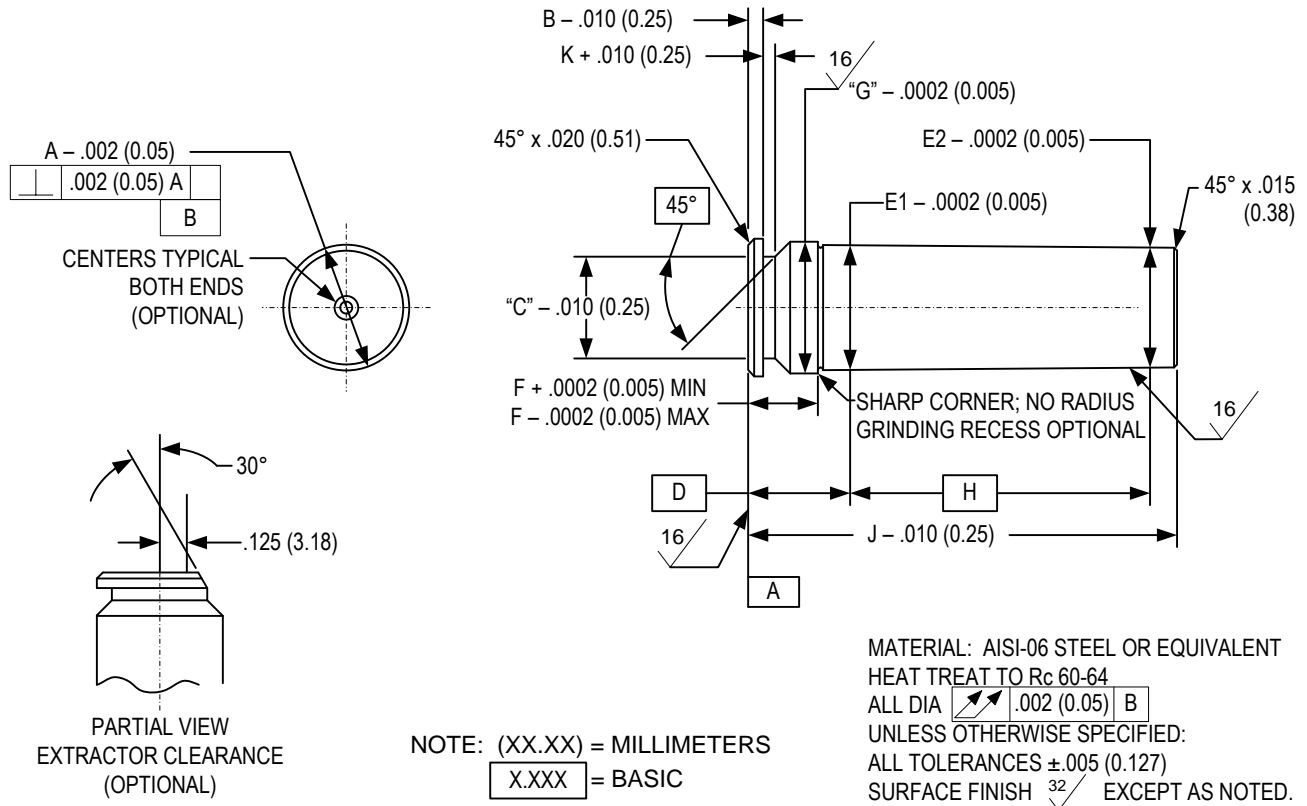

CARTRIDGE NAME	A	B	C	BASIC D	E1	E2	F		G	BASIC H	J	K
							MIN	MAX				
7mm Remington Magnum	0.532	0.050	0.475	0.250	0.5106	0.4898	0.220	0.227	0.532	1.720	2.010	0.037
	(13.51)	(1.27)	(12.07)	(6.35)	(12.969)	(12.441)	(5.59)	(5.77)	(13.51)	(43.69)	(51.05)	(0.94)
7mm Shooting Times Westerner	0.532	0.050	0.475	0.250	0.5106	0.4896	0.220	0.227	0.532	1.750	2.040	0.037
	(13.51)	(1.27)	(12.07)	(6.35)	(12.969)	(12.436)	(5.59)	(5.77)	(13.51)	(44.45)	(51.82)	(0.94)
7mm Weatherby Magnum	0.531	0.051	0.457	0.250	0.5107	0.4932	0.220	0.224	0.532	1.750	2.020	0.049
	(13.49)	(1.30)	(11.61)	(6.35)	(12.972)	(12.527)	(5.59)	(5.69)	(13.51)	(44.45)	(51.31)	(1.24)
8mm Remington Magnum	0.532	0.050	0.475	0.250	0.5106	0.4896	0.220	0.227	0.532	1.750	2.040	0.037
	(13.51)	(1.27)	(12.07)	(6.35)	(12.969)	(12.436)	(5.59)	(5.77)	(13.51)	(44.45)	(51.82)	(0.94)
257 Weatherby Magnum	0.531	0.051	0.457	0.250	0.5107	0.4932	0.220	0.224	0.532	1.750	2.014	0.049
	(13.49)	(1.30)	(11.61)	(6.35)	(12.972)	(12.527)	(5.59)	(5.69)	(13.51)	(44.45)	(51.16)	(1.24)

II. GAUGES FOR BELT-BREECHING CARTRIDGES (Cont'd)

CARTRIDGE NAME	A	B	C	BASIC D	E1	E2	F		G	BASIC H	J	K
							MIN	MAX				
264 Winchester Magnum	0.532	0.050	0.475	0.250	0.5106	0.4902	0.220	0.227	0.532	1.700	1.990	0.037
	(13.51)	(1.27)	(12.07)	(6.35)	(12.969)	(12.451)	(5.59)	(5.77)	(13.51)	(43.18)	(50.55)	(0.94)
270 Weatherby Magnum	0.531	0.051	0.457	0.250	0.5107	0.4932	0.220	0.224	0.532	1.750	2.014	0.049
	(13.49)	(1.30)	(11.61)	(6.35)	(12.972)	(12.527)	(5.59)	(5.69)	(13.51)	(44.45)	(51.16)	(1.24)
300 H&H Magnum	0.532	0.050	0.475	0.250	0.5100	0.4540	0.220	0.227	0.532	1.650	1.940	0.037
	(13.51)	(1.27)	(12.07)	(6.35)	(12.954)	(11.532)	(5.59)	(5.77)	(13.51)	(41.91)	(49.28)	(0.94)
300 Weatherby Magnum	0.531	0.051	0.457	0.250	0.5107	0.4956	0.220	0.224	0.532	1.750	2.040	0.049
	(13.49)	(1.30)	(11.61)	(6.35)	(12.972)	(12.588)	(5.59)	(5.69)	(13.51)	(44.45)	(51.82)	(1.24)
300 Winchester Magnum	0.532	0.050	0.475	0.250	0.5106	0.4895	0.220	0.227	0.532	1.750	2.040	0.037
	(13.51)	(1.27)	(12.07)	(6.35)	(12.969)	(12.433)	(5.59)	(5.77)	(13.51)	(44.45)	(51.82)	(0.94)
338 Winchester Magnum	0.532	0.050	0.475	0.250	0.5106	0.4905	0.220	0.227	0.532	1.670	1.960	0.037
	(13.51)	(1.27)	(12.07)	(6.35)	(12.969)	(12.459)	(5.59)	(5.77)	(13.51)	(42.42)	(49.78)	(0.94)
340 Weatherby Magnum	0.531	0.051	0.457	0.250	0.5107	0.4956	0.220	0.224	0.532	1.750	2.040	0.049
	(13.49)	(1.30)	(11.61)	(6.35)	(12.972)	(12.588)	(5.59)	(5.69)	(13.51)	(44.45)	(51.82)	(1.24)
350 Remington Magnum	0.532	0.050	0.475	0.250	0.5107	0.4941	0.220	0.227	0.532	1.380	1.670	0.037
	(13.51)	(1.27)	(12.07)	(6.35)	(12.972)	(12.550)	(5.59)	(5.77)	(13.51)	(35.05)	(42.42)	(0.94)
375 H&H Magnum	0.532	0.050	0.475	0.250	0.5101	0.4610	0.220	0.227	0.532	1.650	1.940	0.037
	(13.51)	(1.27)	(12.07)	(6.35)	(12.957)	(11.709)	(5.59)	(5.77)	(13.51)	(41.91)	(49.28)	(0.94)
416 Remington Magnum	0.532	0.050	0.475	0.250	0.5106	0.4896	0.220	0.227	0.532	1.750	2.040	0.037
	(13.51)	(1.27)	(12.07)	(6.35)	(12.969)	(12.436)	(5.59)	(5.77)	(13.51)	(44.45)	(51.82)	(0.94)
416 Weatherby Magnum	0.579	0.063	0.495	0.280	0.5807	0.5641	0.253	0.257	0.603	1.750	2.070	0.049
	(14.71)	(1.60)	(12.57)	(7.11)	(14.750)	(14.328)	(6.43)	(6.53)	(15.32)	(44.45)	(52.58)	(1.24)
450 Marlin	0.532	0.050	0.475	0.280	0.5111	0.4817	0.252	0.259	0.532	1.720	2.040	0.037
	(13.51)	(1.27)	(12.07)	(7.11)	(12.982)	(12.235)	(6.40)	(6.58)	(13.51)	(43.69)	(51.82)	(0.94)
458 Lott	0.532	0.050	0.475	0.250	0.5106	0.4825	0.220	0.227	0.532	2.350	2.640	0.037
	(13.51)	(1.27)	(12.07)	(6.35)	(12.969)	(12.256)	(5.59)	(5.77)	(13.51)	(59.69)	(67.06)	(0.94)
458 Winchester Magnum	0.532	0.050	0.475	0.250	0.5106	0.4817	0.220	0.227	0.532	2.150	2.440	0.037
	(13.51)	(1.27)	(12.07)	(6.35)	(12.969)	(12.235)	(5.59)	(5.77)	(13.51)	(54.61)	(61.98)	(0.94)

III. GAUGES FOR RIM-BREECHING CARTRIDGES

FIGURE III
RIM-BREECHING CENTERFIRE RIFLE HEADSPACE GAUGES

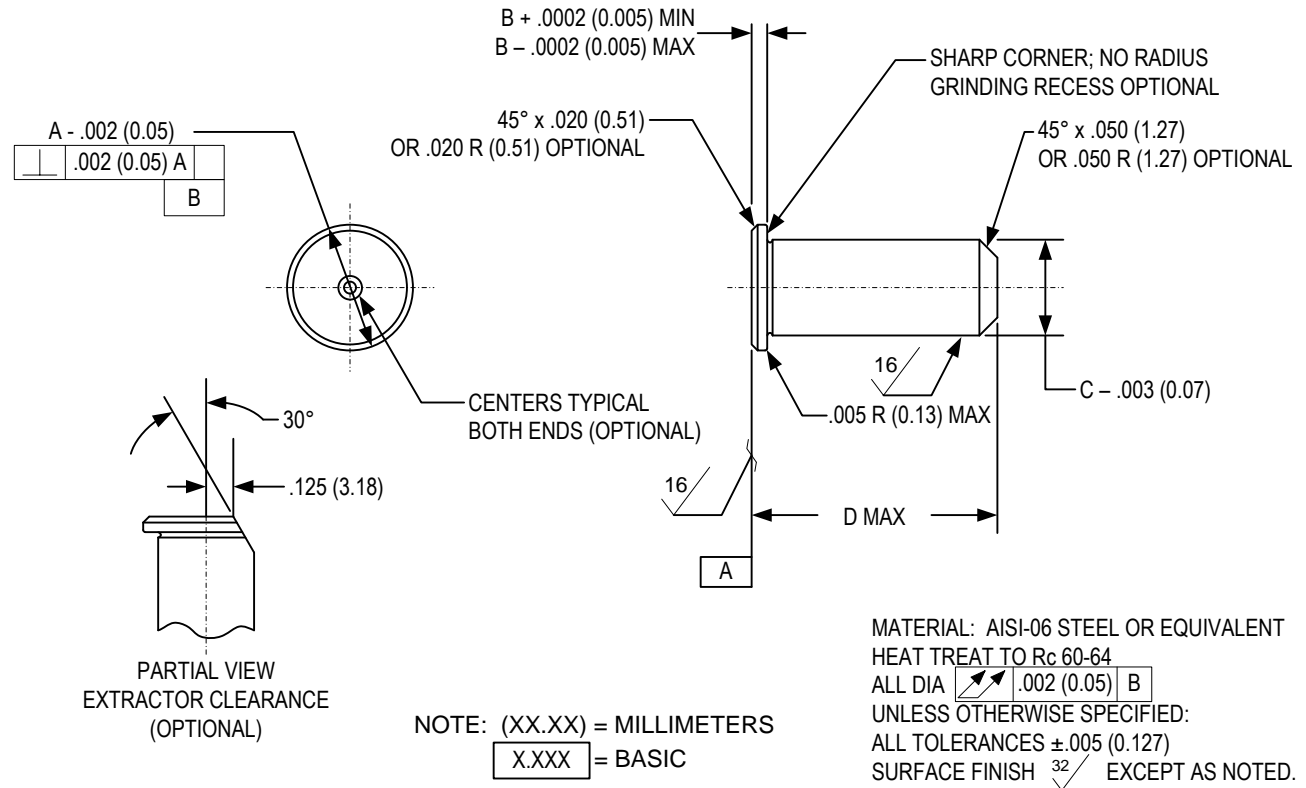

CARTRIDGE NAME	A	B		C	D
		MIN	MAX		
7-30 Waters	0.506 (12.85)	0.0630 (1.600)	0.0700 (1.778)	0.3981 (10.112)	1.5764 (40.041)
17 Hornet	0.408 (10.36)	0.0650 (1.651)	0.0720 (1.829)	0.3314 (8.418)	0.9133 (23.198)
218 Bee	0.408 (10.36)	0.0650 (1.651)	0.0720 (1.829)	0.3314 (8.418)	0.9133 (23.198)
22 Hornet	0.350 (8.89)	0.0650 (1.651)	0.0720 (1.829)	0.2763 (7.018)	0.8427 (21.405)
25-20 Winchester	0.408 (10.36)	0.0650 (1.651)	0.0720 (1.829)	0.3322 (8.438)	0.8573 (21.775)
25-35 Winchester	0.506 (12.85)	0.0630 (1.600)	0.0700 (1.778)	0.3631 (9.223)	1.3701 (34.801)
30-30 Winchester	0.506 (12.85)	0.0630 (1.600)	0.0700 (1.778)	0.4003 (10.168)	1.4305 (36.335)
30-40 Krag	0.545 (13.84)	0.0640 (1.626)	0.0710 (1.803)	0.4180 (10.617)	1.7151 (43.564)

III. GAUGES FOR RIM-BREECHING CARTRIDGES (Cont'd)

CARTRIDGE NAME	A	B		C	D
		MIN	MAX		
303 British	0.540 (13.72)	0.0640 (1.626)	0.0710 (1.803)	0.4000 (10.160)	1.7801 (45.215)
307 Winchester	0.506 (12.85)	0.0630 (1.600)	0.0700 (1.778)	0.4530 (11.506)	1.5498 (39.365)
32 Winchester Special	0.506 (12.85)	0.0630 (1.600)	0.0700 (1.778)	0.4014 (10.196)	1.4361 (36.477)
32-20 Winchester	0.408 (10.36)	0.0650 (1.651)	0.0720 (1.829)	0.3414 (8.672)	0.8712 (22.128)
348 Winchester	0.610 (15.49)	0.0700 (1.778)	0.0770 (1.956)	0.4841 (12.296)	1.6399 (41.653)
356 Winchester	0.506 (12.85)	0.0630 (1.600)	0.0700 (1.778)	.4530 (11.506)	1.5498 (39.365)
375 Winchester	0.506 (12.85)	0.0630 (1.600)	0.0700 (1.778)	0.3990 (10.135)	1.7900 (45.466)
38-40 Winchester	0.525 (13.34)	0.0650 (1.651)	0.0720 (1.829)	0.4533 (11.514)	0.9124 (23.175)
38-55 Winchester	0.506 (12.85)	0.0630 (1.600)	0.0700 (1.778)	0.3912 (9.936)	2.0750 (52.705)
405 Winchester	0.543 (13.79)	0.0730 (1.854)	0.0800 (2.032)	0.4350 (11.049)	2.5730 (65.354)
44 Remington Magnum	0.514 (13.06)	0.0600 (1.524)	0.0700 (1.778)	0.4550 (11.557)	1.2750 (32.385)
44-40 Winchester	0.525 (13.34)	0.0650 (1.651)	0.0720 (1.829)	0.4558 (11.577)	0.9175 (23.305)
444 Marlin	0.514 (13.06)	0.0630 (1.600)	0.0700 (1.778)	0.4520 (11.481)	2.2150 (56.261)
45-70 Government	0.608 (15.44)	0.0700 (1.7780)	0.0770 (1.9558)	0.4790 (12.167)	2.0950 (74.930)
457 Wild West Guns					
470 Nitro Express	0.6551 (16.640)	0.0400 (1.016)	0.0470 (1.194)	0.5312 (13.492)	2.3749 (60.322)
475 Turnbull	0.610 (15.49)	0.0700 (1.778)	0.0770 (1.956)	0.5371 (13.642)	1.6788 (42.642)
500 Nitro Express 3"	0.655 (16.64)	0.0409 (1.039)	0.0479 (1.217)	2.9990 (76.170)	2.9900 (75.950)

IV. GAUGES FOR MOUTH-BREACHING CARTRIDGES

FIGURE IV
 MOUTH-BREACHING CENTERFIRE RIFLE HEADSPACE GAUGES

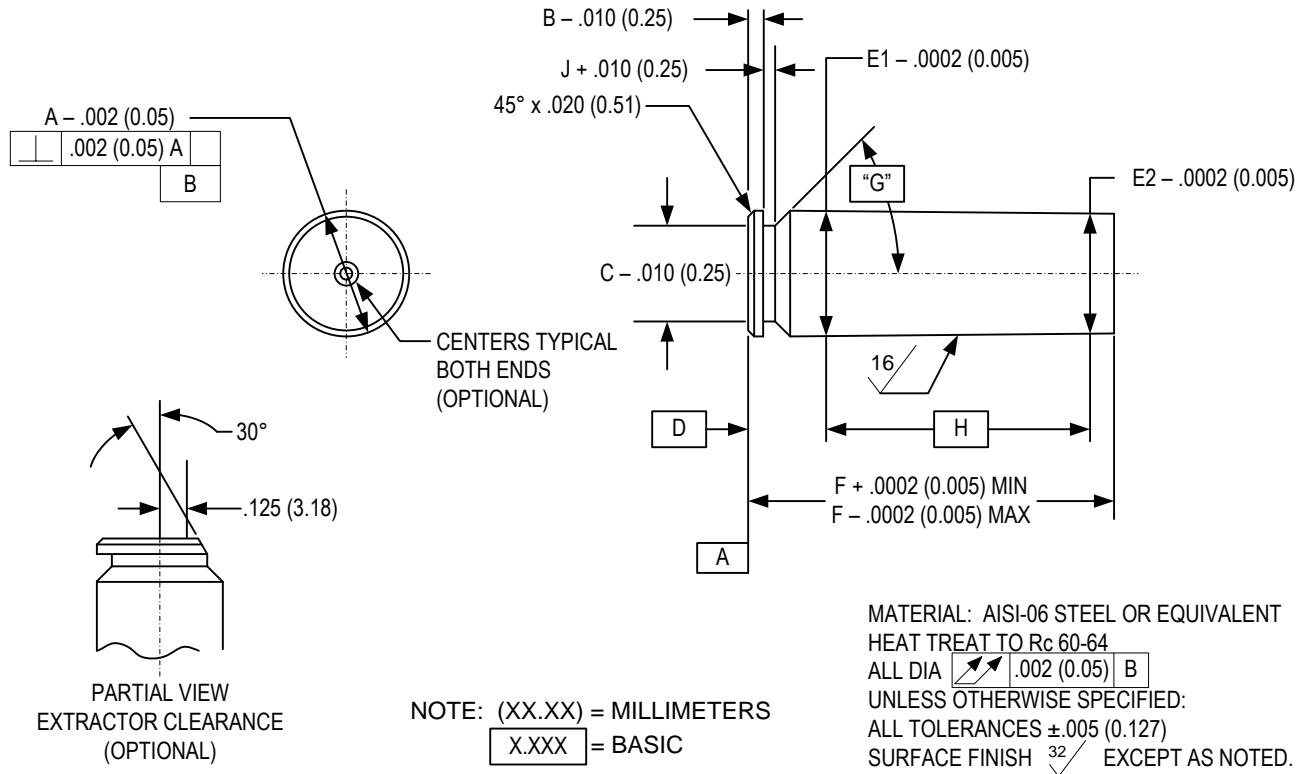

CARTRIDGE NAME	A	B	C	BASIC D	E1	E2	F		BASIC		J
							MIN	MAX	G	H	
30 Carbine	0.360	0.050	0.310	0.2000	0.3545	0.3428	1.2900	1.3000	32°	0.6700	0.033
	(9.14)	(1.27)	(7.87)	(5.080)	(9.004)	(8.707)	(32.766)	(33.020)		(17.018)	(0.838)
450 Bushmaster	0.473	0.054	0.409	0.2000	0.5009	0.4810	1.7000	1.7100	40°	1.3500	0.040
	(12.01)	(1.37)	(10.39)	(5.080)	(12.723)	(12.217)	(43.180)	(43.434)		(34.290)	(1.02)

**EQUIPMENT:
REFERENCE AMMUNITION SUPPLY**

NOTE: Refer to Section III – page 223, *Supplier Contact Information*, for detailed information on contacting the manufacturers of listed products and the SAAMI Technical Office.

Centerfire rifle reference ammunition for the verification of ranges, barrels, and other equipment may be obtained from the manufacturer. Contact the SAAMI Technical Office or see website for detailed information.

The SAAMI Technical Office maintains current assessment data. SAAMI policy does not allow the release of assessment values by the manufacturer of reference ammunition. All assessments are to be supplied by the SAAMI Technical Office.

**EQUIPMENT:
REFERENCE AMMUNITION ORDER PROCEDURE**

Each order should contain the following information, in the following order:

1. Number of rounds desired. (See NOTE, below.)
2. Appropriate order symbol, when given.
3. Designation “SAAMI Reference Ammunition”.
4. Cartridge name.
5. SAAMI lot number. (Current lot numbers are given on latest assessment value sheets issued by the SAAMI Technical Office.)

EXAMPLE:

100 rounds, Order symbol SA22H2
SAAMI Reference Ammunition
22 Hornet
SAAMI Lot 22HOR-46-11WW

NOTE: Recommended maximum order = 100 rounds. If an individual user has requirements for larger quantities, refer to Section II – page 182.

Manufacturers of SAAMI reference ammunition may limit the order quantities honored to the recommended maximum in order to prevent premature consumption of a lot.

It is up to the discretion of the manufacturer to produce lots of sufficient size to reasonably provide a five-year supply.

SUPPLIER CONTACT INFORMATION

Contact the SAAMI Technical Office using the information below or visit www.saami.org for a current list of supplier contact information.

SAAMI Technical Office *SAAMI Information*
11 Mile Hill Road
Newtown, CT 06470
Phone: 203-426-4358
E-mail:
Website: www.saami.org

**EQUIPMENT:
 SCHEMATIC LAYOUT OF VELOCITY SCREENS**

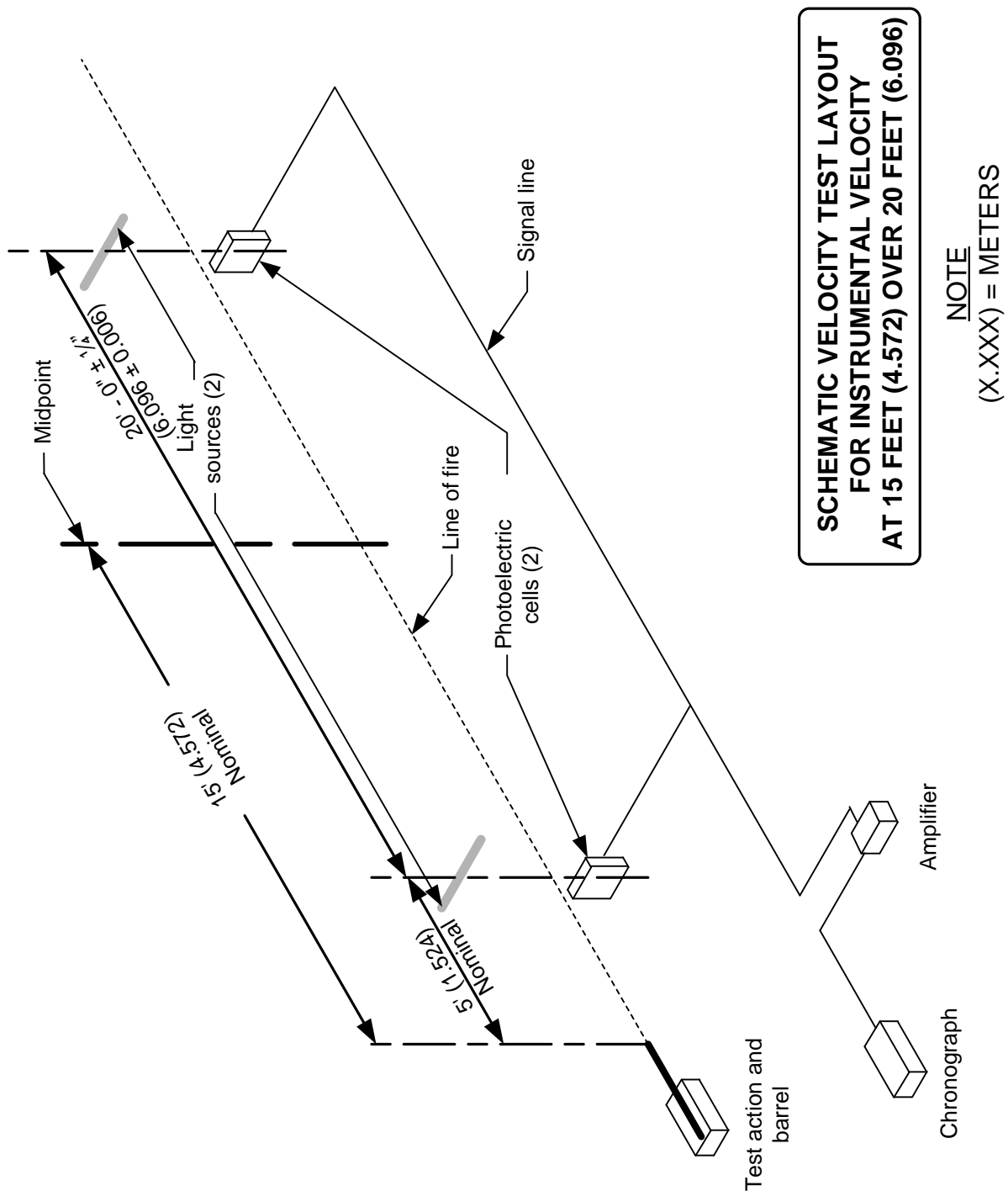

**EQUIPMENT:
UNIVERSAL RECEIVER COLLAR & TEST BARREL**

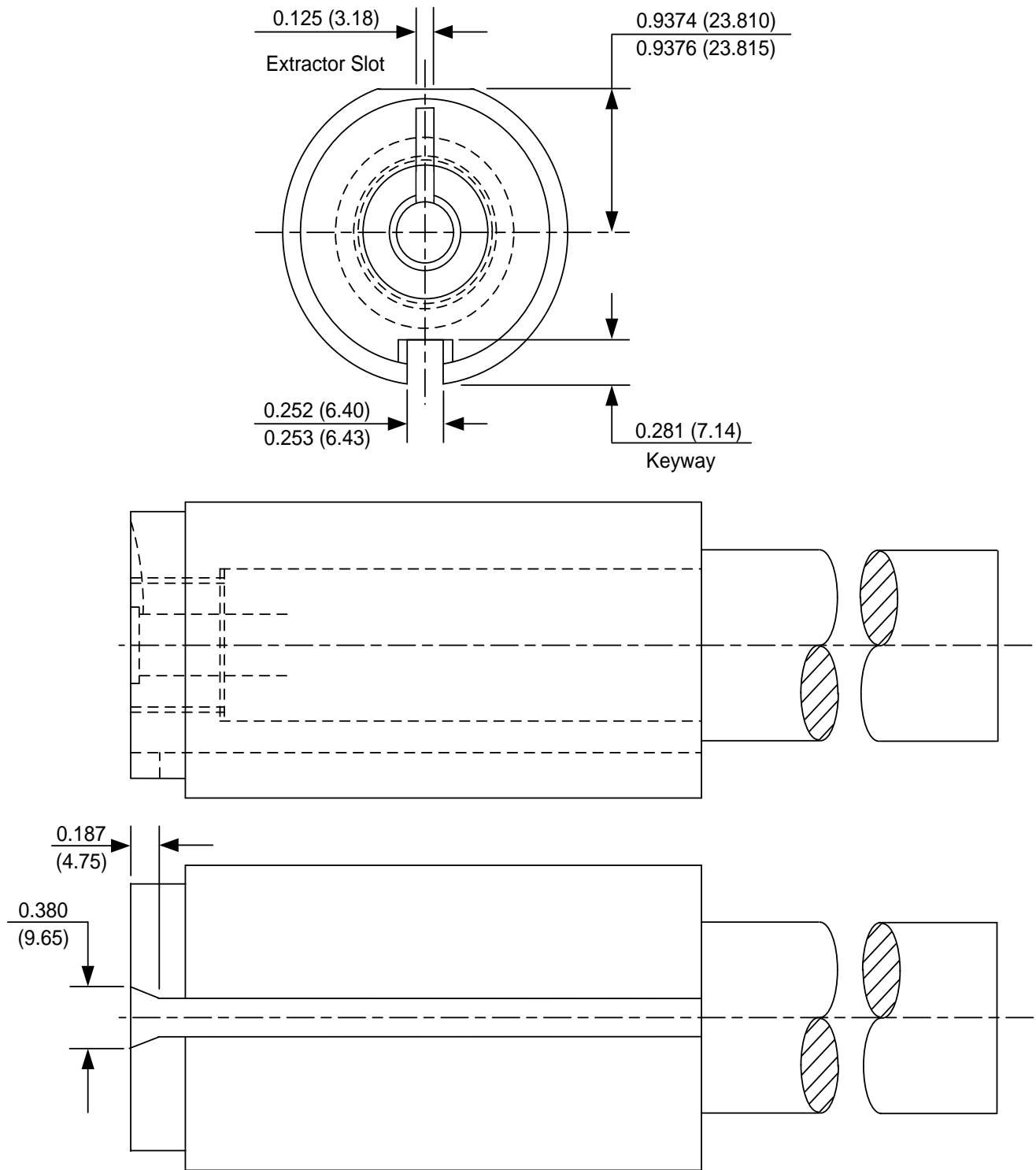

FOR DETAIL INFORMATION SEE FOLLOWING PAGE

NOTE: (XX.XX) = Millimeters

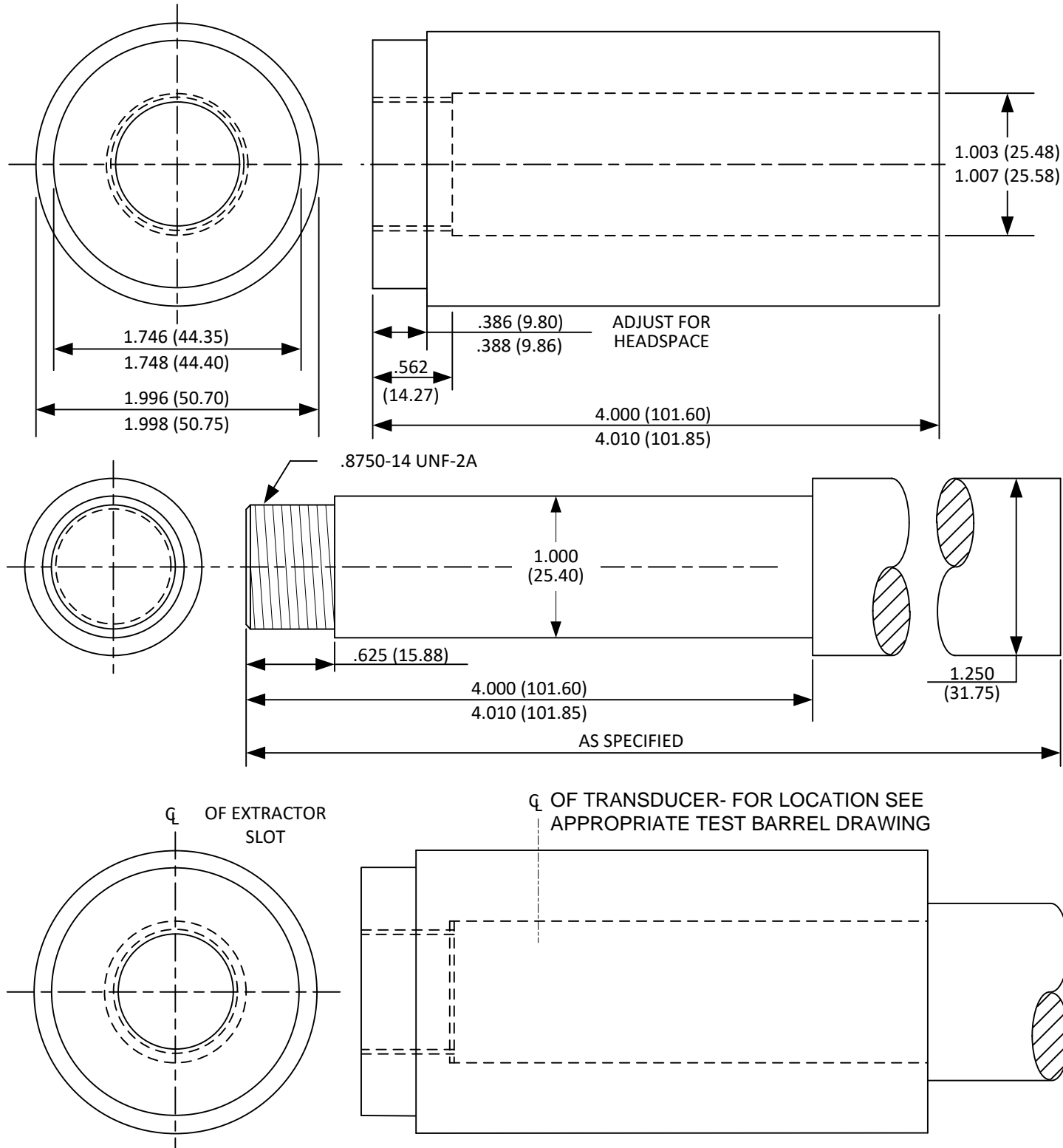

DRAW BARREL AND COLLAR TIGHT.
 TRANSDUCER HOLE AND HEAD CUTS MADE
 AFTER ASSEMBLY - SEE SUBSECTION 3475
 NOTE: (XX.XX) = MILLIMETERS

MATERIAL: RESULTURIZED 4140 STEEL HEAT
 TREAT PRIOR TO MACHINING TO BRINELL
 HARDNESS 277 TO 321 (R_c 29 TO 35)
 ACCEPTABLE ALTERNATE: 416 STAINLESS STEEL

**UNIVERSAL RECEIVER TEST BARREL:
 INSTALLATION OF PRESSURE TRANSDUCERS**

1. LARGE [.250 (6.35)] DIAMETER GAUGES

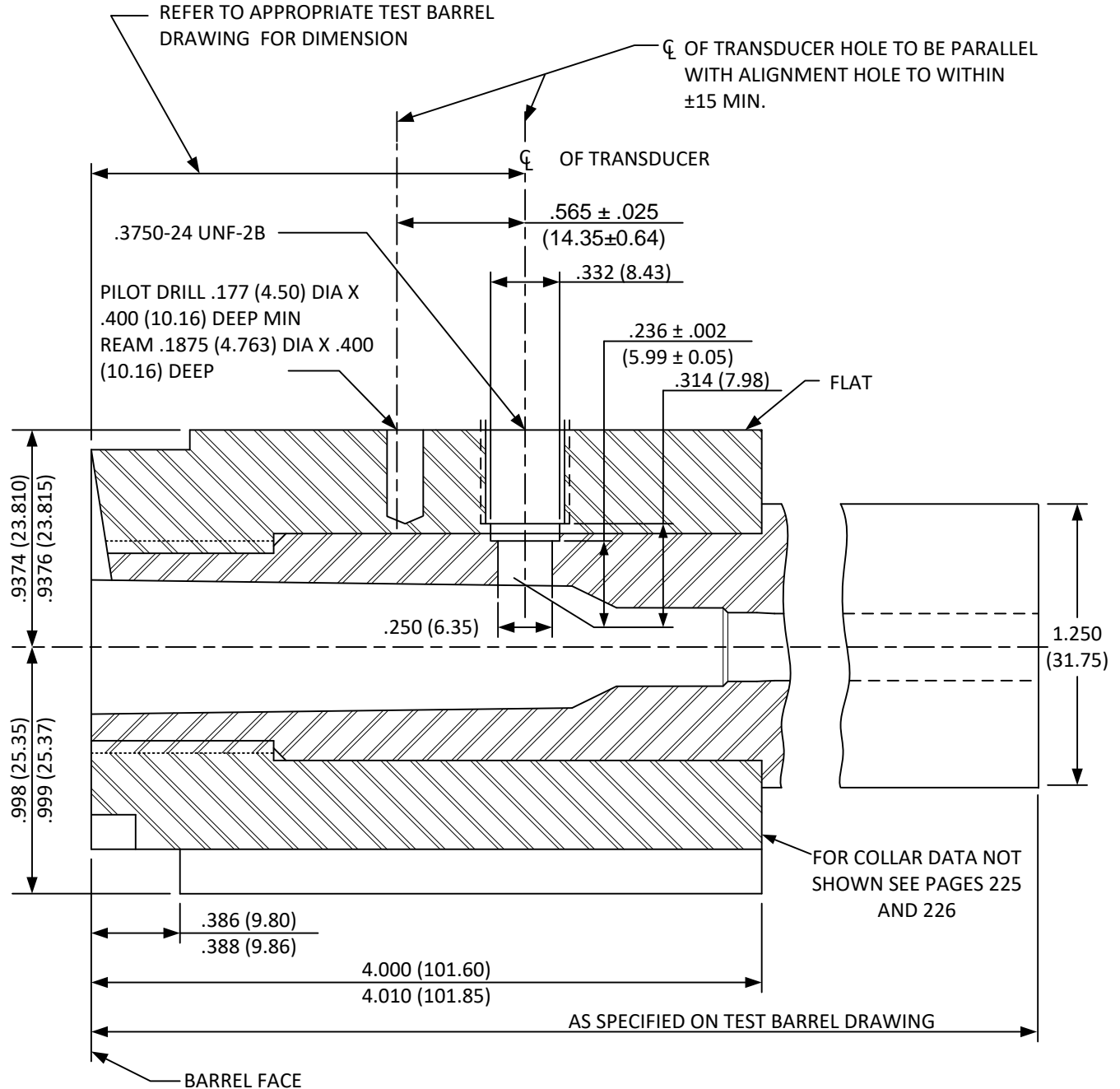

NOTE
 (XX.XX) = MILLIMETERS

**UNIVERSAL RECEIVER TEST BARREL:
 INSTALLATION OF PRESSURE TRANSDUCERS**

2. SMALL [.196 (4.98)] DIAMETER GAUGES

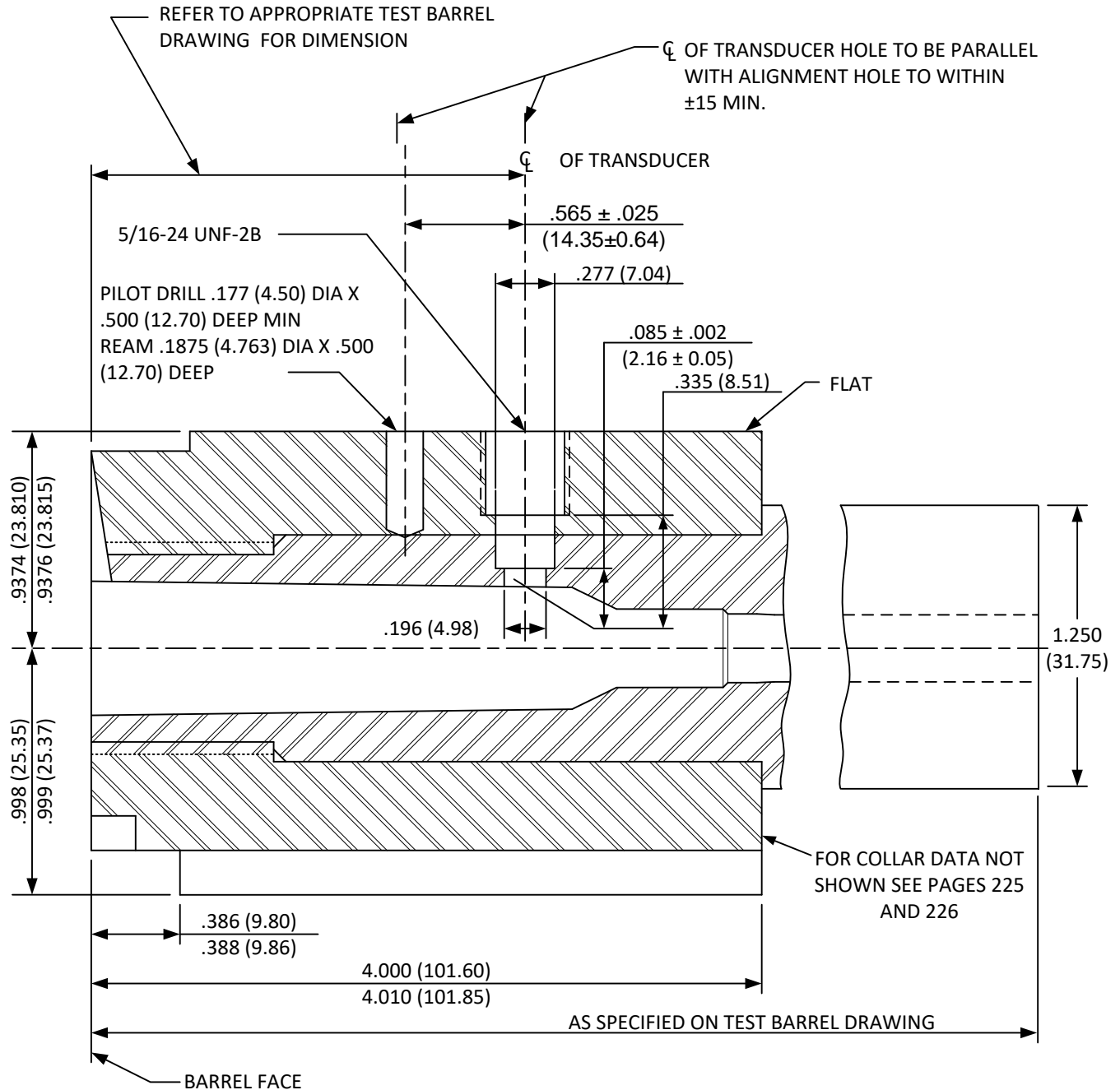

NOTE
 (XX.XX) = MILLIMETERS

**EQUIPMENT:
TRANSDUCER CALIBRATION FIXTURE PLUG
WITH O-RING SEAL (OPTIONAL)***

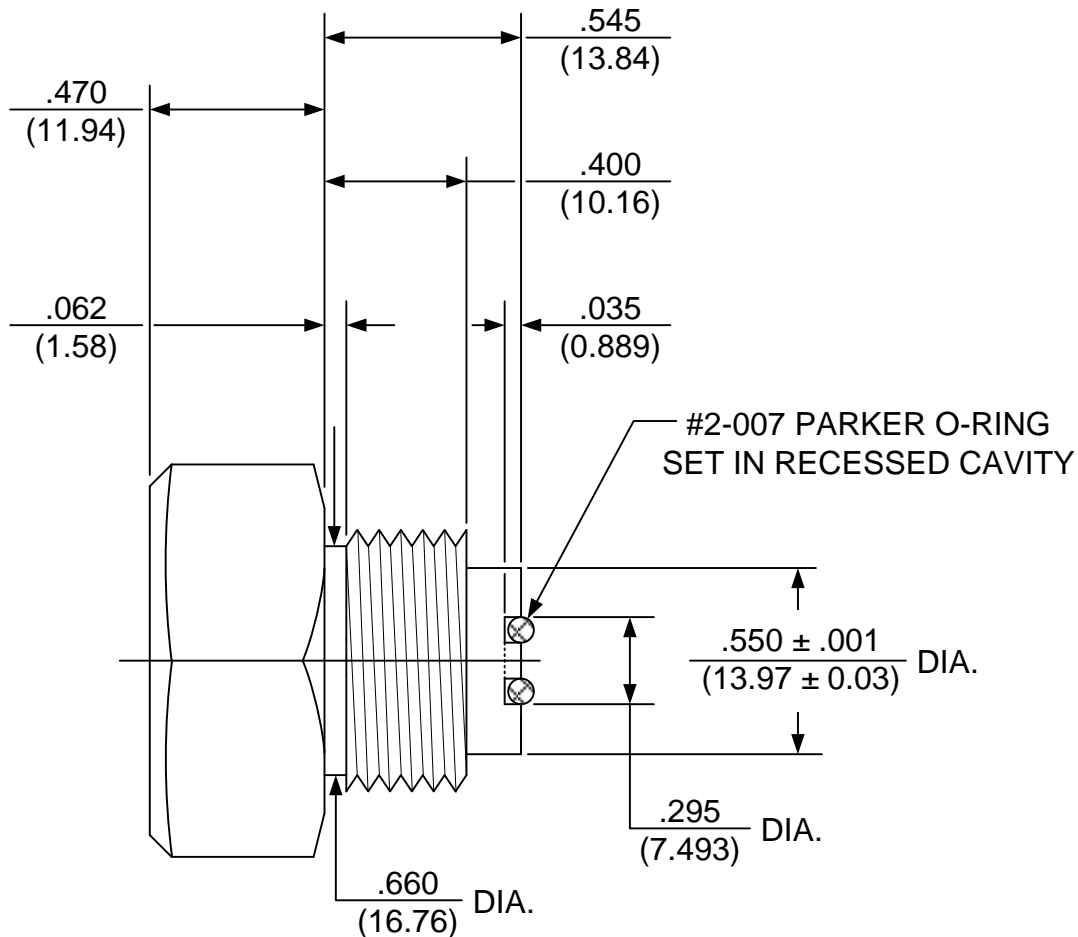

NOTES

MATERIAL: 3/4-16 UNF X 1 1/2 LONG R.H. (GRADE 8) STEEL HEX BOLT
ALL DIA. TO BE CONCENTRIC WITHIN .001 T.I.R.
UNLESS OTHERWISE NOTED ALL TOLERANCES ARE ± .005 (0.13)
* NOT TO EXCEED 65,000 PSI.

TRANSDUCER LOCATION CRITERIA

I. Transducer Location

The following criteria for transducer location positioning should be followed when designing new cartridges. In those cases where following the criteria will cause the transducer to be located over current or projected bullet heel locations, case cannellures, or other undesirable areas, the best alternate location should be chosen. In general, the location should be as close to the bullet heel as practical.

A. Straight-walled Cartridge Cases

The centerline of the transducer shall be located behind the heel of the bullet by an amount equal to one-half the transducer diameter plus 0.005” – 0.010” (0.13 mm – 0.25 mm). This criterion applies to both large diameter [0.250” (6.35 mm)] and small diameter [0.194” (4.93 mm)] transducers.

B. Bottleneck Cartridge Cases

The centerline of the transducer shall be located behind the shell case shoulder intersection by an amount of 0.175” (4.44 mm) for large diameter [0.250” (6.35 mm)] transducers and by 0.150” (3.80 mm) for small diameter [0.194” (4.93 mm)] transducers.

II. Transducer Diameter

A. Large Diameter [0.250” (6.35 mm)] Transducers

This size is selected when the chamber diameter at transducer centerline is equal to or greater than 0.350” (8.89 mm).

B. Small Diameter [0.194” (4.93 mm)] Transducers

This size is selected when the chamber diameter at transducer centerline is less than 0.350” (8.89 mm).

**STANDARD V&P TEST BARRELS - GENERAL:
PROCEDURES FOR DIMENSIONING CHAMBERS**

Chamber and bore dimensions of velocity and pressure test barrels shall conform to the dimensions of the chamber and bore at Maximum Material Condition (MMC) for each cartridge as originally introduced. Fabrication tolerances, however, are much reduced.

It is recognized that changes may be made to cartridge or chamber dimensions in order to improve the velocity-pressure relationship, accuracy or functioning in rifles as production experience indicates. However, none of these changes should be of such nature that they would cause a significant increase in pressure level of a given lot of ammunition.

No changes shall be made to velocity and pressure barrel dimensions which would result in a reduction of the recorded pressure level of any given lot of ammunition. This would result in the possibility of future lots of ammunition being loaded with increased powder charges, which would cause increased pressure in existing rifles.

Production barrels may be adapted for velocity and pressure testing provided that they conform to all dimensions shown on the appropriate test barrel drawing.

Except as noted below, all standard test barrels shall be 24.00 inches long (609.6 mm). Exterior ballistic data for all centerfire rifle cartridges shall be based on this length.

Exceptions - Test barrel lengths for the following calibers are as shown:

- 7.62x39 – 20.00 inches (508.0mm)
- 30 Carbine – 20.00 inches (508.0mm)
- 300 AAC Blackout – 16.00 inches (406.4 mm)
- 350 Remington Magnum – 20.00 inches (508.0mm)
- 44 Remington Magnum – 20.00 inches (508.0mm)

**STANDARD V&P TEST BARRELS - GENERAL:
PROCEDURES FOR MEASURING BARREL LENGTH**

Centerfire rifle test barrels are measured by inserting a rod down the bore from the muzzle until it touches the breech face with the action closed and the firing pin retracted.

A stop collar or other means is utilized to mark the point on the rod adjacent to the most forward part of the barrel or the bottom of the counterbore in barrels having a counterbore recess at the muzzle.

The rod is removed and the distance from the mark to the end of the rod is measured. This measurement is recorded as the barrel length.

6x45mm V&P Test Barrel

Issued: 01/18/2010

Revised: 08/16/2015

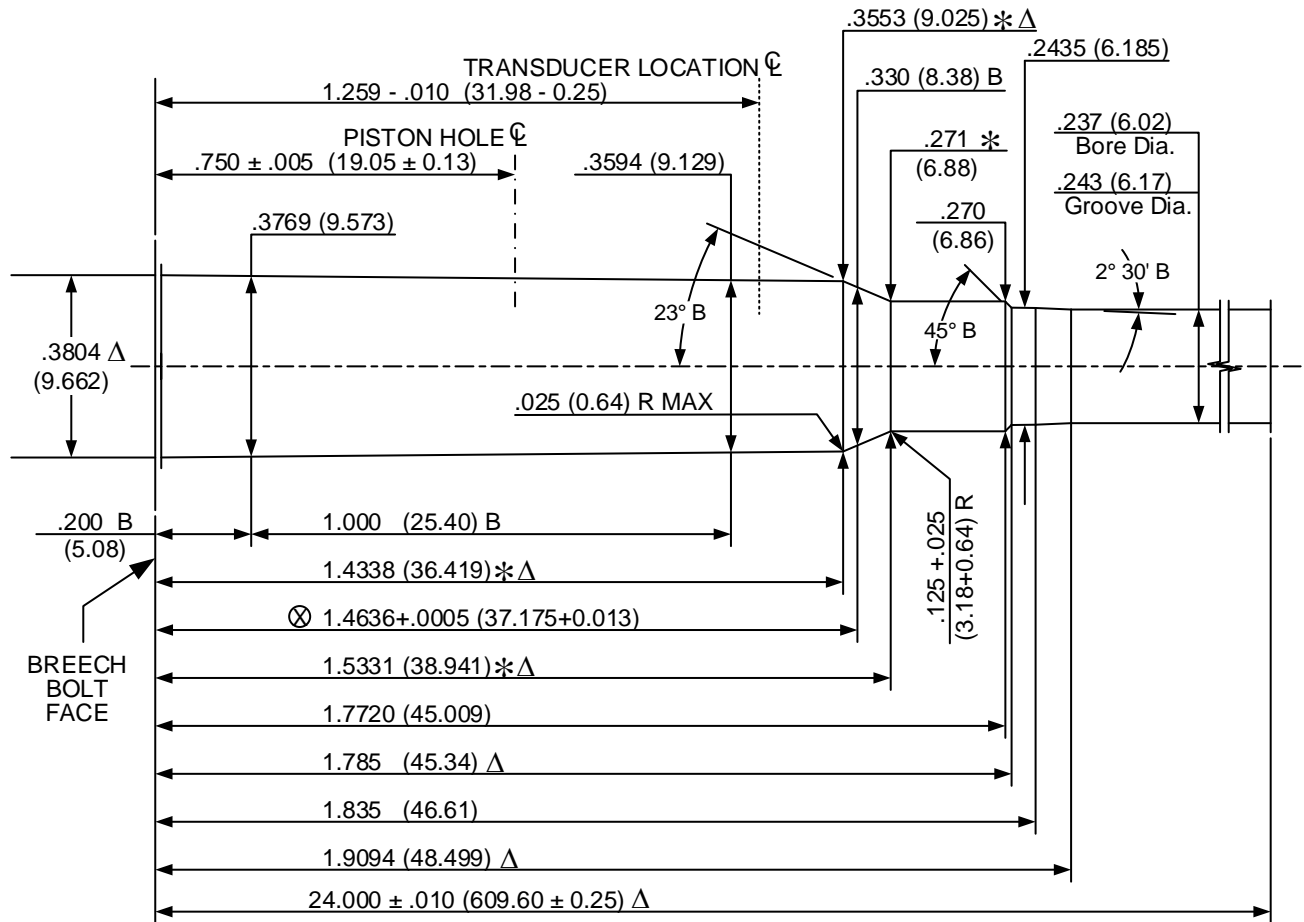

DO NOT SCALE FROM DRAWING

- NUMBER OF GROOVES: 6
- WIDTH OF GROOVES: .074 + .002 (1.88 + 0.05)
- TWIST RATE: 12.00 (304.8) R.H.
- DIAMETER OF PISTON HOLE: Crusher pressures not established
- TRANSDUCER DIAMETER: .250 (6.35)

LAND AND GROOVE DIMENSIONS TO BE WITHIN TOLERANCES THROUGHOUT LENGTH OF BARREL.

UNLESS OTHERWISE NOTED, ALL DIAMETERS +.0005 (0.013) LENGTH TOLERANCE + .005 (0.13)

NOTE:

- B = BASIC
- Δ = REFERENCE DIMENSION
- ⊗ = HEADSPACE DIMENSION
- * DIMENSIONS ARE TO INTERSECTIONS OF LINES
- (XX.XX) = MILLIMETERS
- ALL CALCULATIONS APPLY AT MAXIMUM MATERIAL CONDITION (MMC)

6mm Remington V&P Test Barrel

Issued: 05/20/1980

Revised: 08/16/2015

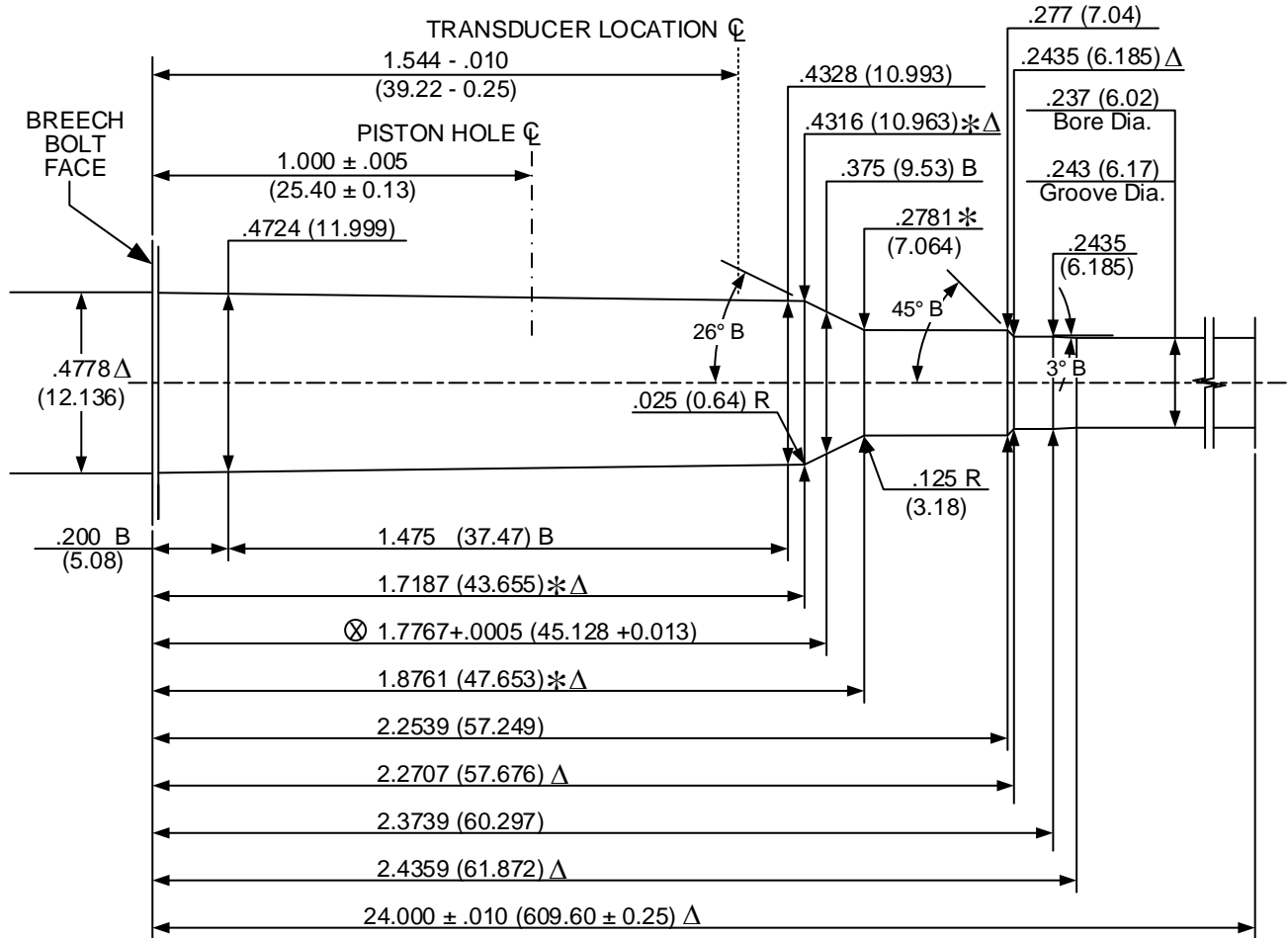

DO NOT SCALE FROM DRAWING

NUMBER OF GROOVES: 6
 WIDTH OF GROOVES: $.090 + .002$ (2.29 + 0.05)
 TWIST RATE: 9.00 (228.6) R.H.
 DIAMETER OF PISTON HOLE: $.206$ (5.23)
 TRANSDUCER DIAMETER: $.250$ (6.35)

LAND AND GROOVE DIMENSIONS TO BE WITHIN TOLERANCES THROUGHOUT LENGTH OF BARREL.

UNLESS OTHERWISE NOTED, ALL DIAMETERS $+.0005$ (0.013) LENGTH TOLERANCE $+.005$ (0.13)

NOTE:

B = BASIC Δ = REFERENCE DIMENSION \otimes = HEADSPACE DIMENSION
 * DIMENSIONS ARE TO INTERSECTIONS OF LINES (XX.XX) = MILLIMETERS
 ALL CALCULATIONS APPLY AT MAXIMUM MATERIAL CONDITION (MMC)

6.5 Creedmoor V&P Test Barrel

Issued: 06/17/2009

Revised: 08/16/2015

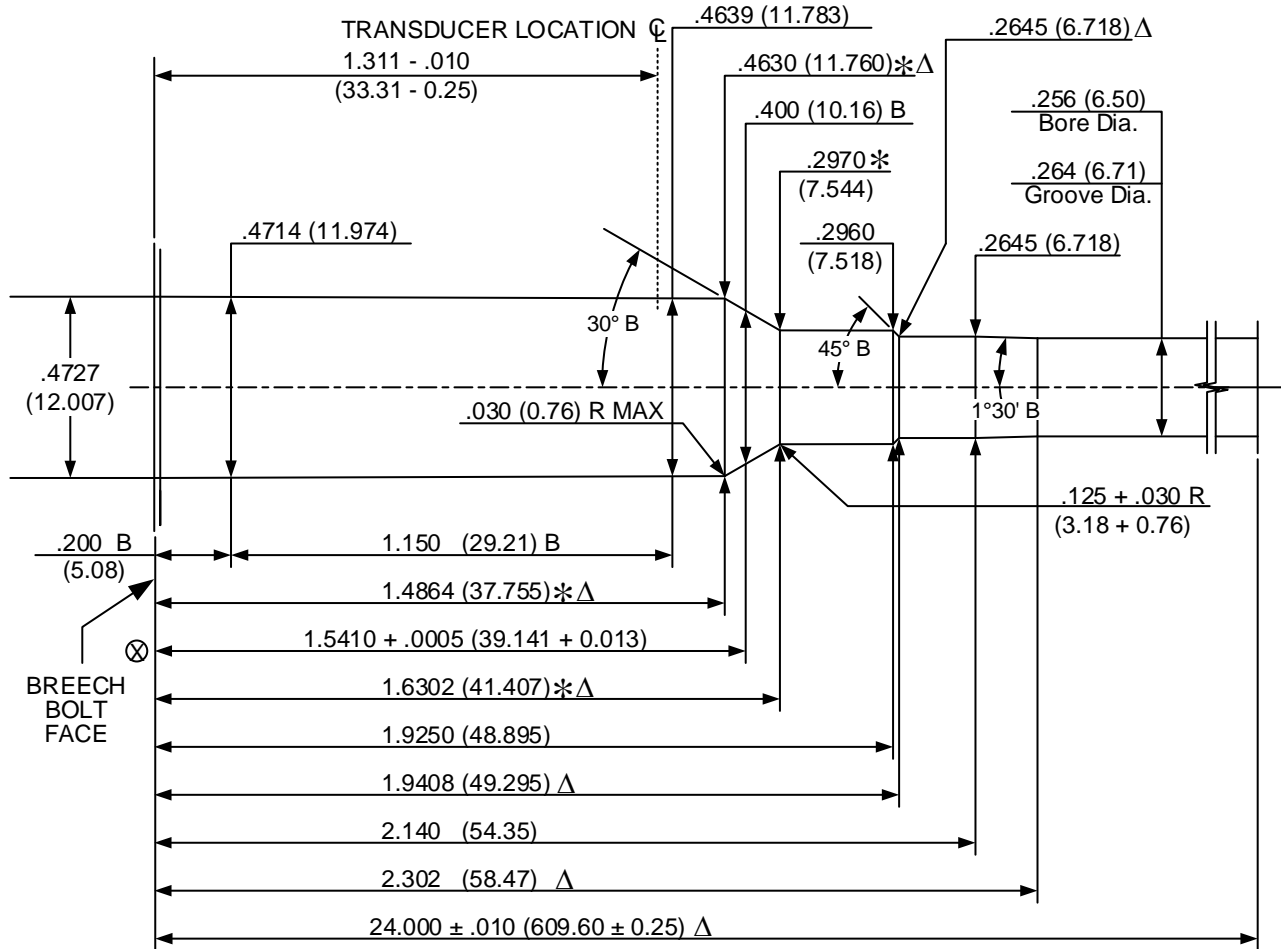

DO NOT SCALE FROM DRAWING

- NUMBER OF GROOVES: 6
- WIDTH OF GROOVES: .090 + .002 (2.29 + 0.05)
- TWIST RATE: 8.00 (203.2) R.H.
- DIAMETER OF PISTON HOLE: Crusher pressures not established.
- TRANSDUCER DIAMETER: .250 (6.35)

LAND AND GROOVE DIMENSIONS TO BE WITHIN TOLERANCES THROUGHOUT LENGTH OF BARREL.

UNLESS OTHERWISE NOTED, ALL DIAMETERS +.0005 (0.013) LENGTH TOLERANCE + .005 (0.13)

NOTE:

- B = BASIC
- Δ = REFERENCE DIMENSION
- ⊗ = HEADSPACE DIMENSION
- * DIMENSIONS ARE TO INTERSECTIONS OF LINES
- (XX.XX) = MILLIMETERS
- ALL CALCULATIONS APPLY AT MAXIMUM MATERIAL CONDITION (MMC)

6.5 Grendel V&P Test Barrel

Issued: 01/17/2011

Revised: 08/16/2015

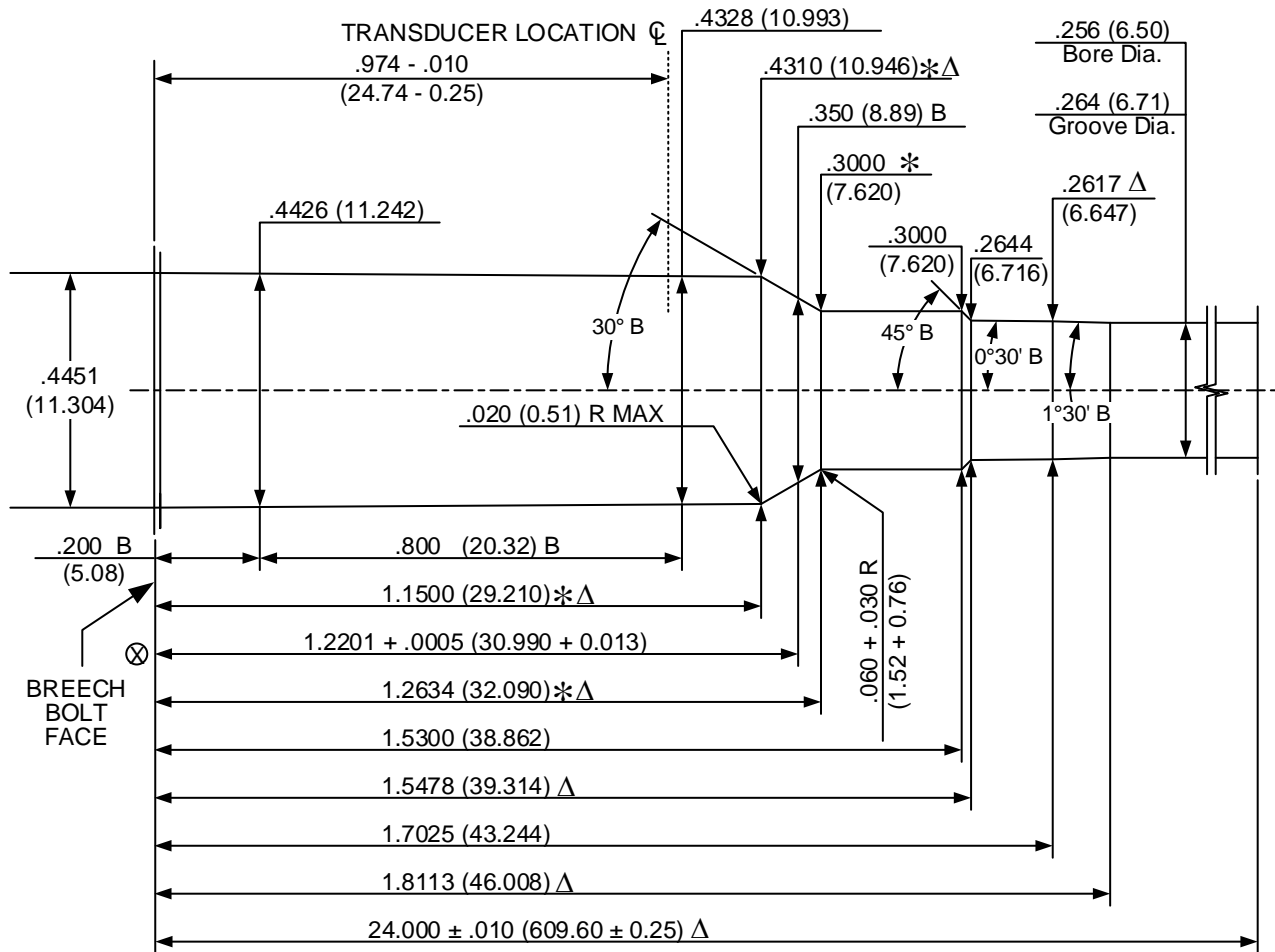

DO NOT SCALE FROM DRAWING

- NUMBER OF GROOVES: 6
- WIDTH OF GROOVES: .090 + .002 (2.29 + 0.05)
- TWIST RATE: 8.00 (203.2) R.H.
- DIAMETER OF PISTON HOLE: Crusher pressures not established.
- TRANSDUCER DIAMETER: .250 (6.35)

LAND AND GROOVE DIMENSIONS TO BE WITHIN TOLERANCES THROUGHOUT LENGTH OF BARREL.

UNLESS OTHERWISE NOTED, ALL DIAMETERS +.0005 (0.013) LENGTH TOLERANCE + .005 (0.13)

NOTE:

- B = BASIC
- Δ = REFERENCE DIMENSION
- ⊗ = HEADSPACE DIMENSION
- * DIMENSIONS ARE TO INTERSECTIONS OF LINES
- (XX.XX) = MILLIMETERS
- ALL CALCULATIONS APPLY AT MAXIMUM MATERIAL CONDITION (MMC)

6.5 x 55 Swedish V&P Test Barrel

Issued: 07/28/1993

Revised: 08/16/2015

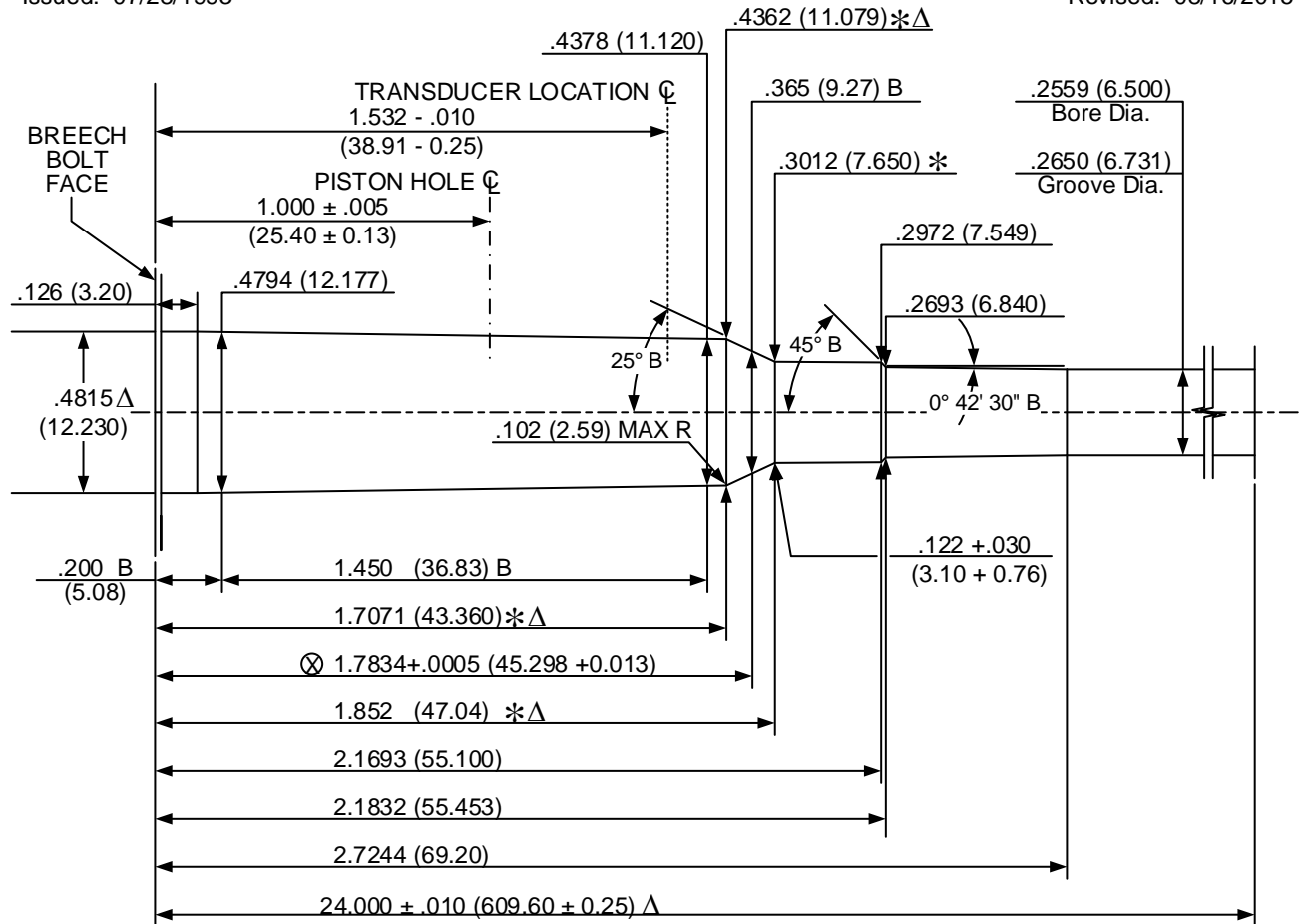

DO NOT SCALE FROM DRAWING

NUMBER OF GROOVES: 4
 WIDTH OF GROOVES: .098 + .002 (2.49 + 0.05)
 TWIST RATE: 8.00 (203.2) R.H.
 DIAMETER OF PISTON HOLE: .206 (5.23)
 TRANSDUCER DIAMETER: .250 (6.35)

LAND AND GROOVE DIMENSIONS TO BE
 WITHIN TOLERANCES THROUGHOUT
 LENGTH OF BARREL.

UNLESS OTHERWISE NOTED,
 ALL DIAMETERS +.0005 (0.013)
 LENGTH TOLERANCE + .005 (0.13)

NOTE:

B = BASIC Δ = REFERENCE DIMENSION ⊗ = HEADSPACE DIMENSION
 * DIMENSIONS ARE TO INTERSECTIONS OF LINES (XX.XX) = MILLIMETERS
 ALL CALCULATIONS APPLY AT MAXIMUM MATERIAL CONDITION (MMC)

6.8mm Remington SPC V&P Test Barrel

Issued: 06/23/2004

Revised: 08/16/2015

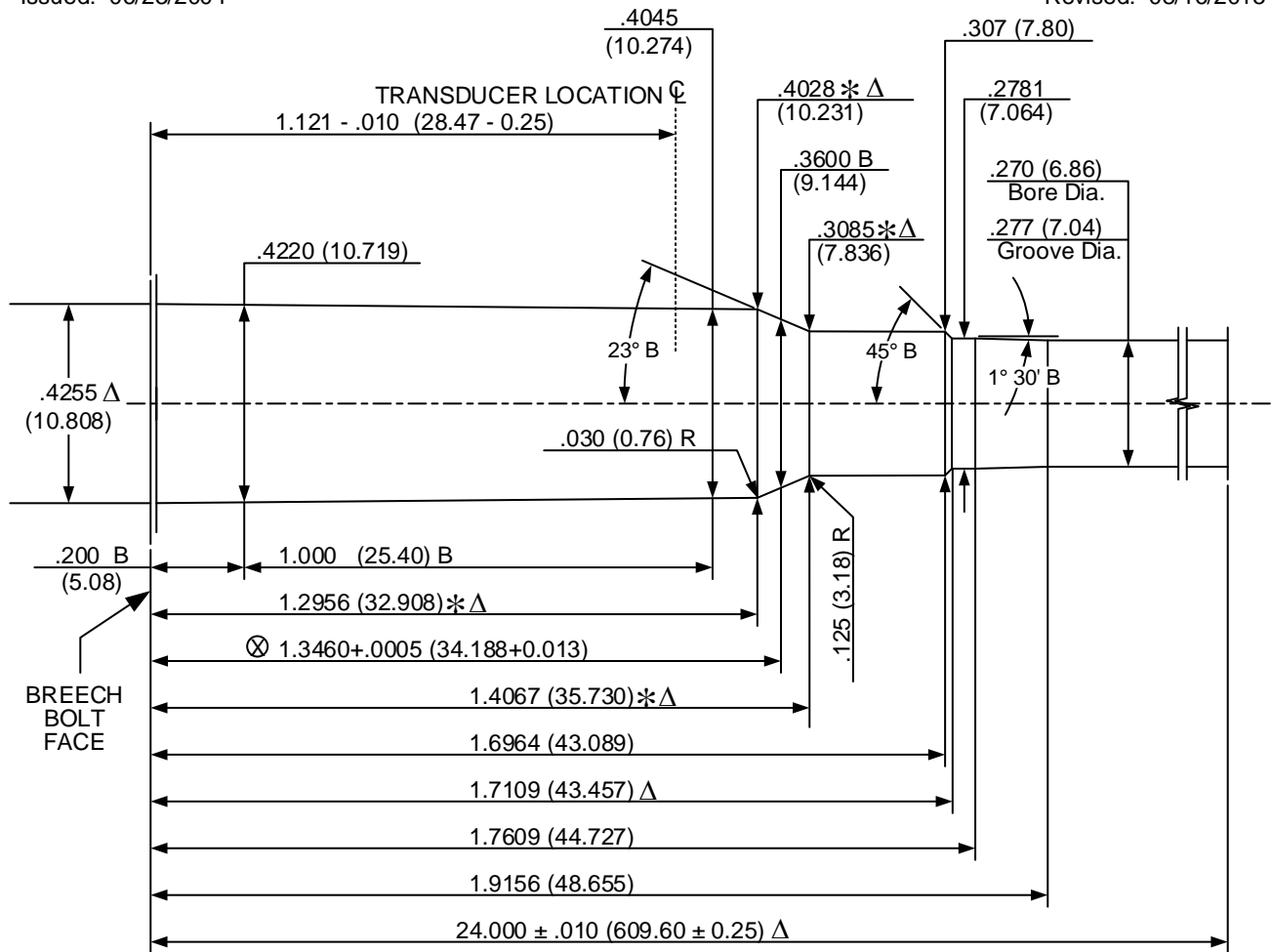

DO NOT SCALE FROM DRAWING

- NUMBER OF GROOVES: 4
- WIDTH OF GROOVES: .160 + .002 (4.06 + 0.05)
- TWIST RATE: 10.00 (254.0) R.H.
- DIAMETER OF PISTON HOLE: Crusher pressures not established
- TRANSDUCER DIAMETER: .250 (6.35)

LAND AND GROOVE DIMENSIONS TO BE WITHIN TOLERANCES THROUGHOUT LENGTH OF BARREL.

UNLESS OTHERWISE NOTED, ALL DIAMETERS +.0005 (0.013) LENGTH TOLERANCE + .005 (0.13)

NOTE:

- B = BASIC
- Δ = REFERENCE DIMENSION
- ⊗ = HEADSPACE DIMENSION
- * DIMENSIONS ARE TO INTERSECTIONS OF LINES
- (XX.XX) = MILLIMETERS
- ALL CALCULATIONS APPLY AT MAXIMUM MATERIAL CONDITION (MMC)

7mm Mauser (7 x 57) V&P Test Barrel

Issued: 01/29/1997

Revised: 08/16/2015

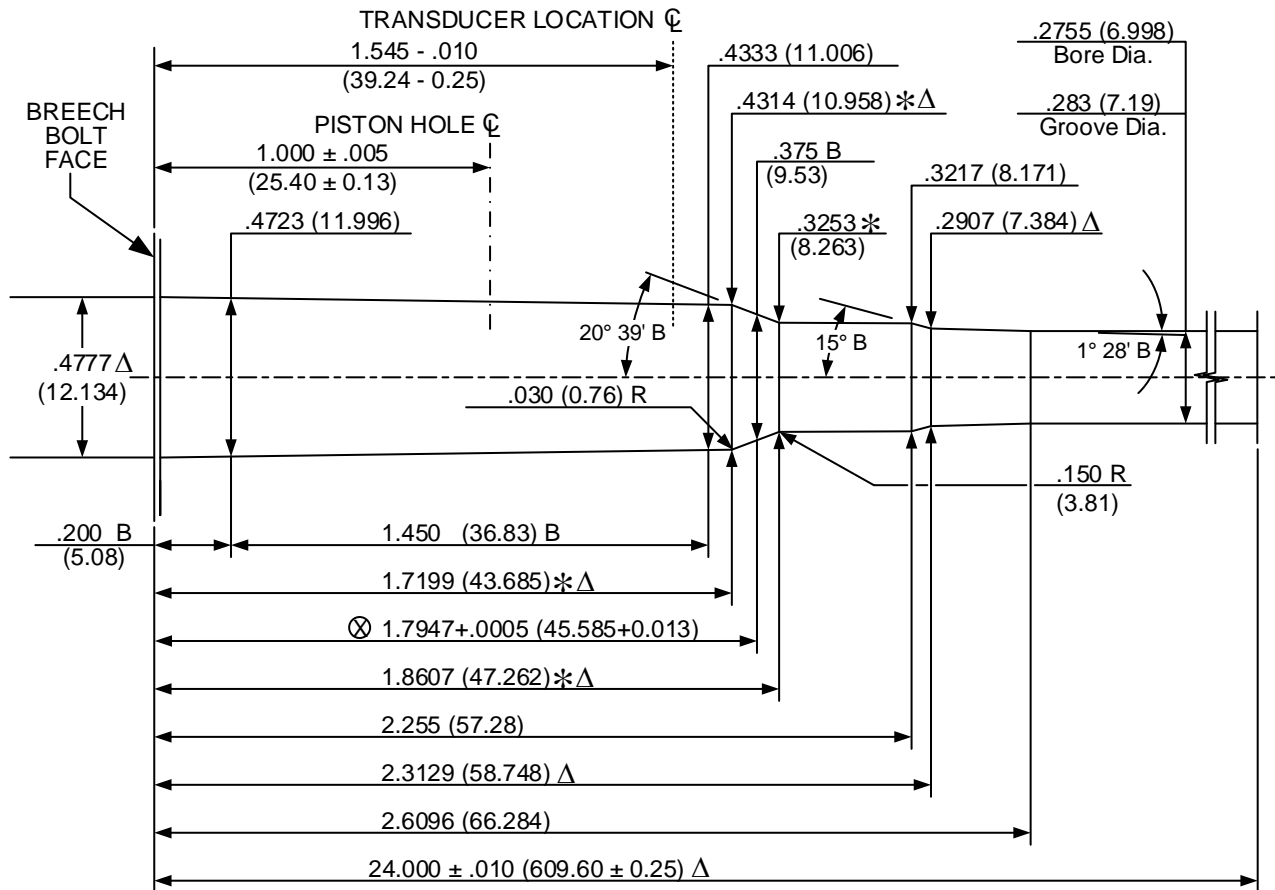

DO NOT SCALE FROM DRAWING

NUMBER OF GROOVES: 4
 WIDTH OF GROOVES: .160 + .002 (4.06 + 0.05)
 TWIST RATE: 8.75 (222.3) [Direction not specified]
 DIAMETER OF PISTON HOLE: .206 (5.23)
 TRANSDUCER DIAMETER: .250 (6.35)

LAND AND GROOVE DIMENSIONS TO BE
 WITHIN TOLERANCES THROUGHOUT
 LENGTH OF BARREL.

UNLESS OTHERWISE NOTED,
 ALL DIAMETERS +.0005 (0.013)
 LENGTH TOLERANCE + .005 (0.13)

NOTE:

B = BASIC Δ = REFERENCE DIMENSION ⊗ = HEADSPACE DIMENSION
 * DIMENSIONS ARE TO INTERSECTIONS OF LINES (XX.XX) = MILLIMETERS
 ALL CALCULATIONS APPLY AT MAXIMUM MATERIAL CONDITION (MMC)

7mm Remington Magnum V&P Test Barrel

Issued: 05/20/1980

Revised: 08/16/2015

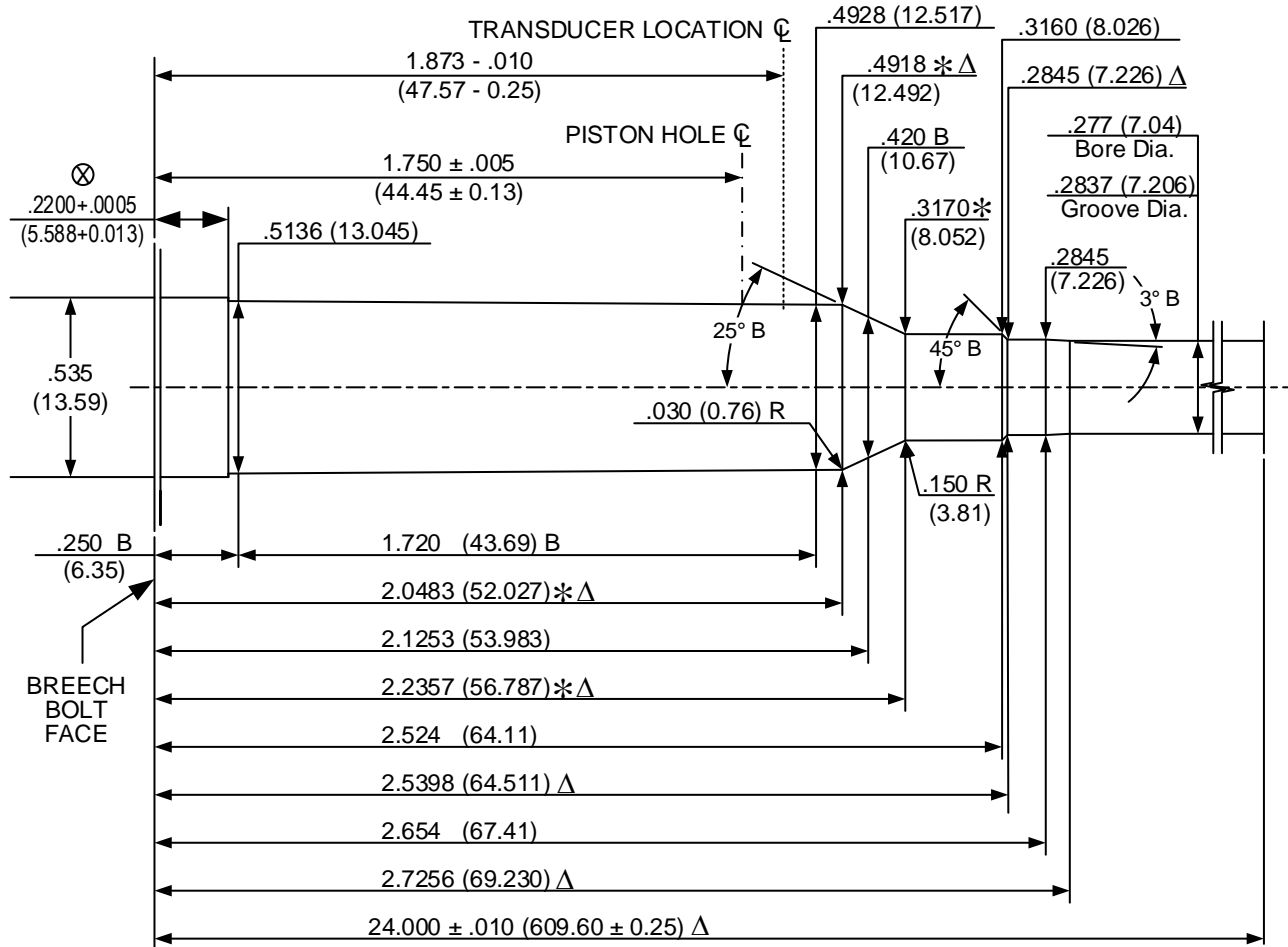

DO NOT SCALE FROM DRAWING

- NUMBER OF GROOVES: 6
- WIDTH OF GROOVES: $.110 + .002$ (2.79 + 0.05)
- TWIST RATE: 9.50 (241.3) R.H.
- DIAMETER OF PISTON HOLE: $.206$ (5.23)
- TRANSDUCER DIAMETER: $.250$ (6.35)

LAND AND GROOVE DIMENSIONS TO BE WITHIN TOLERANCES THROUGHOUT LENGTH OF BARREL.

UNLESS OTHERWISE NOTED, ALL DIAMETERS $+.0005$ (0.013) LENGTH TOLERANCE $+.005$ (0.13)

NOTE:

- B = BASIC
- Δ = REFERENCE DIMENSION
- \otimes = HEADSPACE DIMENSION
- * DIMENSIONS ARE TO INTERSECTIONS OF LINES
- (XX.XX) = MILLIMETERS
- ALL CALCULATIONS APPLY AT MAXIMUM MATERIAL CONDITION (MMC)

7mm Remington Ultra Magnum

Issued: 05/31/2003

Revised: 08/16/2015

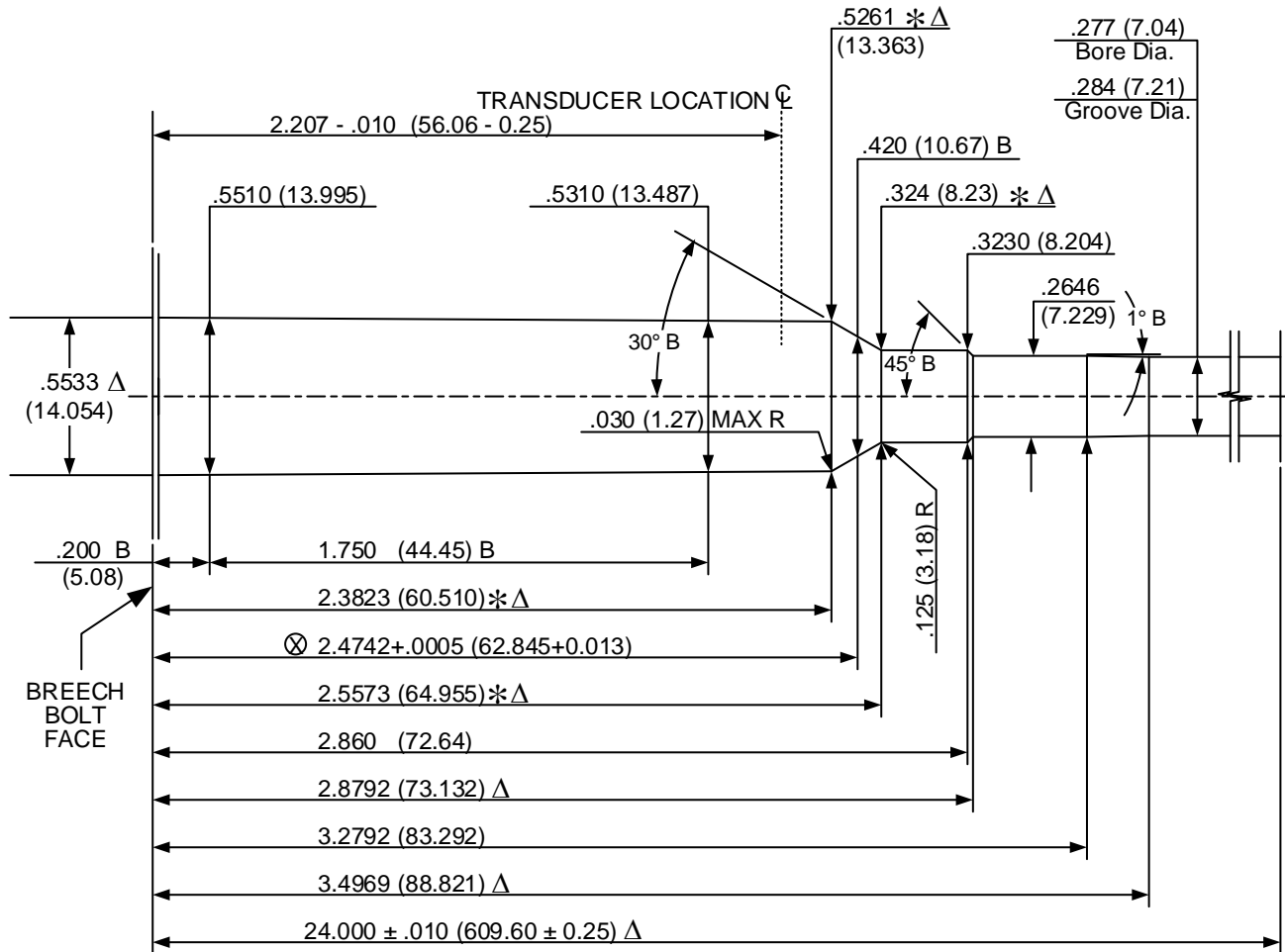

DO NOT SCALE FROM DRAWING

NUMBER OF GROOVES: 6
 WIDTH OF GROOVES: .110 + .002 (2.79 + 0.05)
 TWIST RATE: 9.50 (241.3) R.H.
 DIAMETER OF PISTON HOLE: Crusher pressures not established
 TRANSUDER DIAMETER: .250 (6.35)

LAND AND GROOVE DIMENSIONS TO BE
 WITHIN TOLERANCES THROUGHOUT
 LENGTH OF BARREL.

UNLESS OTHERWISE NOTED,
 ALL DIAMETERS +.0005 (0.013)
 LENGTH TOLERANCE + .005 (0.13)

NOTE:

B = BASIC Δ = REFERENCE DIMENSION ⊗ = HEADSPACE DIMENSION
 * DIMENSIONS ARE TO INTERSECTIONS OF LINES (XX.XX) = MILLIMETERS
 ALL CALCULATIONS APPLY AT MAXIMUM MATERIAL CONDITION (MMC)

7mm Shooting Times Westerner V&P Test Barrel

Issued: 09/16/1996

Revised: 12/28/2004

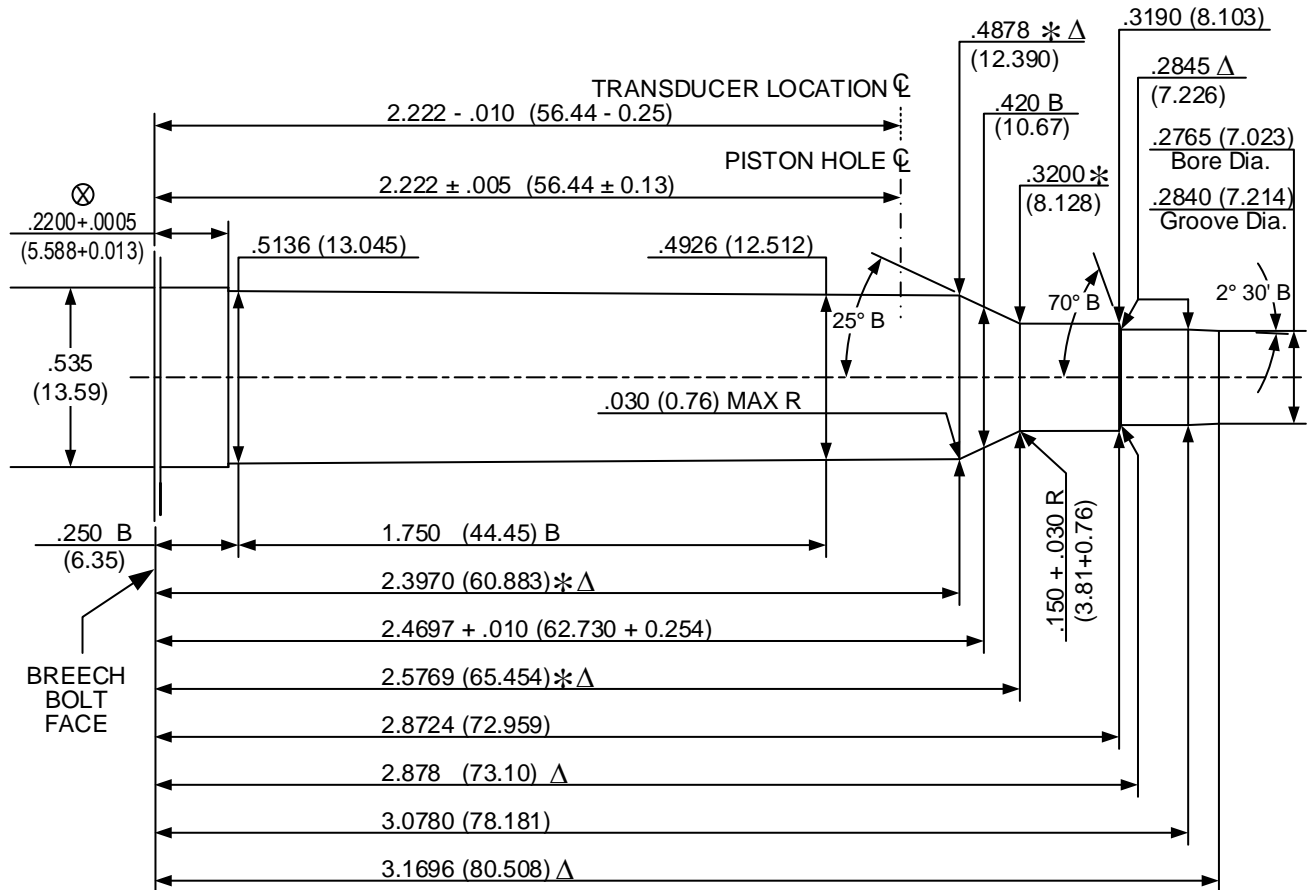

DO NOT SCALE FROM DRAWING

- NUMBER OF GROOVES: 6
- WIDTH OF GROOVES: .113 + .002 (2.87 + 0.05)
- TWIST RATE: 9.50 (241.3) R.H.
- BARREL LENGTH: 24.000 ± .010 (609.60 ± 0.25)
- DIAMETER OF PISTON HOLE: .206 (5.23)
- TRANSDUCER DIAMETER: .250 (6.35)

LAND AND GROOVE DIMENSIONS TO BE WITHIN TOLERANCES THROUGHOUT LENGTH OF BARREL.

UNLESS OTHERWISE NOTED, ALL DIAMETERS +.0005 (0.013) LENGTH TOLERANCE + .005 (0.13)

NOTE:

- B = BASIC
- Δ = REFERENCE DIMENSION
- ⊗ = HEADSPACE DIMENSION
- * DIMENSIONS ARE TO INTERSECTIONS OF LINES
- (XX.XX) = MILLIMETERS
- ALL CALCULATIONS APPLY AT MAXIMUM MATERIAL CONDITION (MMC)

7mm Weatherby Magnum V&P Test Barrel

Issued: 06/04/1991

Revised: 08/16/2015

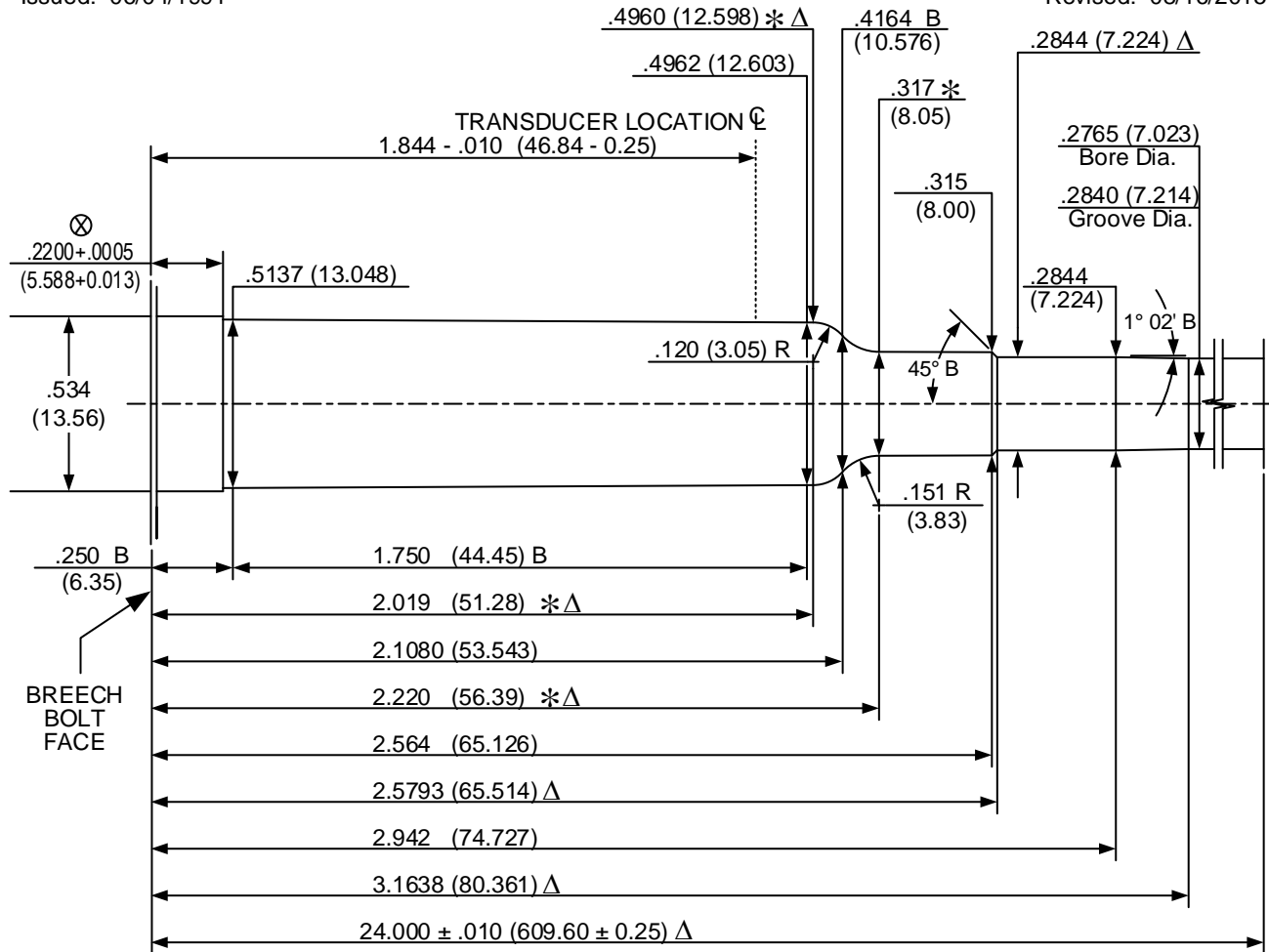

DO NOT SCALE FROM DRAWING

- NUMBER OF GROOVES: 6
- WIDTH OF GROOVES: .113 + .002 (2.87 + 0.05)
- TWIST RATE: 10.00 (254.0) R.H.
- DIAMETER OF PISTON HOLE: Crusher pressure not established.
- TRANSDUCER DIAMETER: .250 (6.35)

LAND AND GROOVE DIMENSIONS TO BE WITHIN TOLERANCES THROUGHOUT LENGTH OF BARREL.

UNLESS OTHERWISE NOTED, ALL DIAMETERS +.0005 (0.013) LENGTH TOLERANCE + .005 (0.13)

NOTE:

- B = BASIC
- Δ = REFERENCE DIMENSION
- ⊗ = HEADSPACE DIMENSION
- * DIMENSIONS ARE TO INTERSECTIONS OF LINES
- (XX.XX) = MILLIMETERS
- ALL CALCULATIONS APPLY AT MAXIMUM MATERIAL CONDITION (MMC)

7mm Winchester Short Magnum

Issued: 05/31/2003

Revised: 08/16/2015

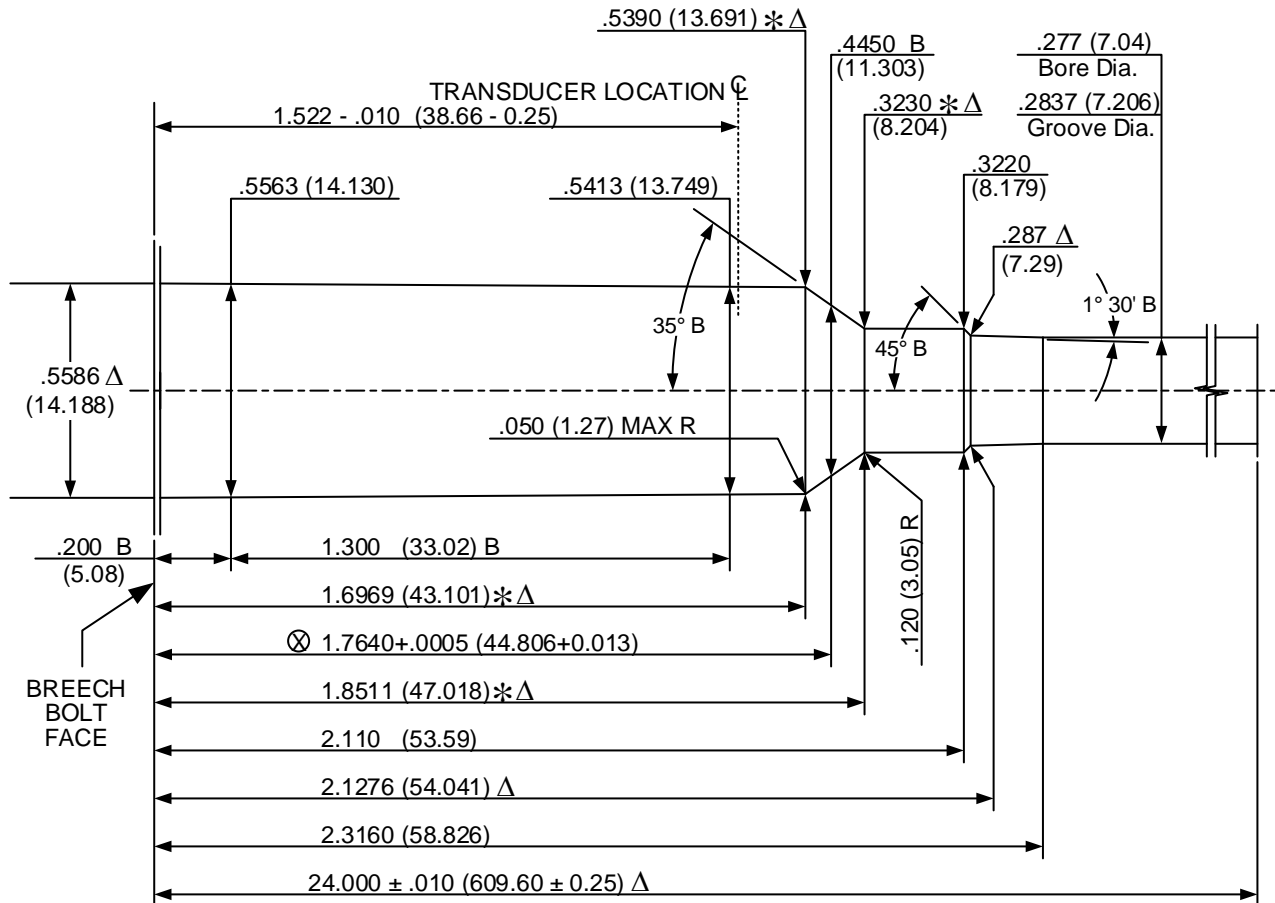

DO NOT SCALE FROM DRAWING

NUMBER OF GROOVES: 6
 WIDTH OF GROOVES: .110 + .002 (2.79 + 0.05)
 TWIST RATE: 9.50 (241.3) R.H.
 DIAMETER OF PISTON HOLE: Crusher pressures not established
 TRANSDUCER DIAMETER: .250 (6.35)

LAND AND GROOVE DIMENSIONS TO BE
 WITHIN TOLERANCES THROUGHOUT
 LENGTH OF BARREL.

UNLESS OTHERWISE NOTED,
 ALL DIAMETERS +.0005 (0.013)
 LENGTH TOLERANCE + .005 (0.13)

NOTE:

B = BASIC Δ = REFERENCE DIMENSION ⊗ = HEADSPACE DIMENSION
 * DIMENSIONS ARE TO INTERSECTIONS OF LINES (XX.XX) = MILLIMETERS
 ALL CALCULATIONS APPLY AT MAXIMUM MATERIAL CONDITION (MMC)

7mm-08 Remington V&P Test Barrel

Issued: 05/20/1980

Revised: 08/16/2015

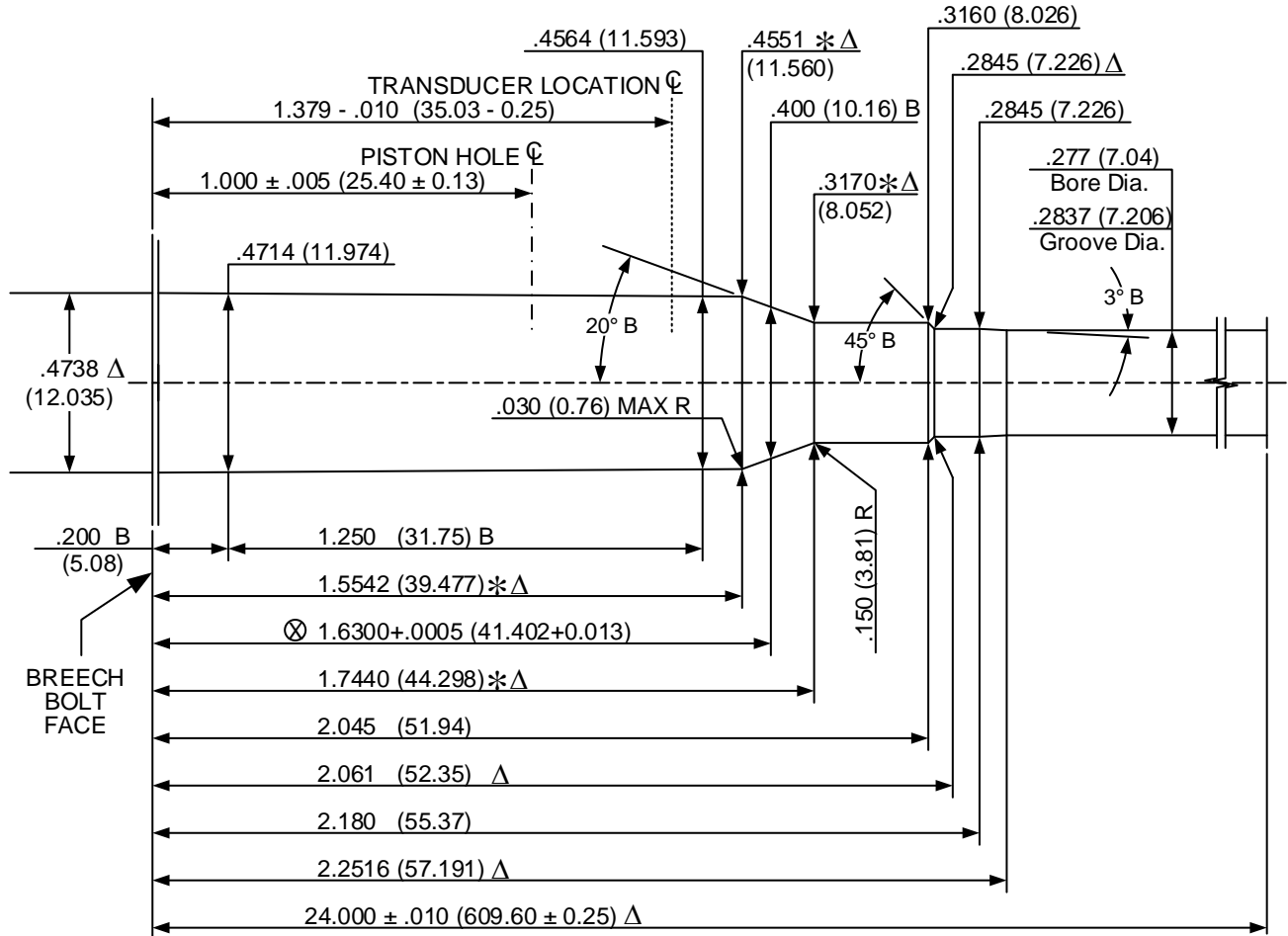

DO NOT SCALE FROM DRAWING

- NUMBER OF GROOVES: 6
- WIDTH OF GROOVES: .110 + .002 (2.79 + 0.05)
- TWIST RATE: 9.50 (241.3) R.H.
- DIAMETER OF PISTON HOLE: .206 (5.23)
- TRANSDUCER DIAMETER: .250 (6.35)

LAND AND GROOVE DIMENSIONS TO BE WITHIN TOLERANCES THROUGHOUT LENGTH OF BARREL.

UNLESS OTHERWISE NOTED, ALL DIAMETERS +.0005 (0.013) LENGTH TOLERANCE + .005 (0.13)

NOTE:

- B = BASIC
- Δ = REFERENCE DIMENSION
- \otimes = HEADSPACE DIMENSION
- * DIMENSIONS ARE TO INTERSECTIONS OF LINES
- (XX.XX) = MILLIMETERS
- ALL CALCULATIONS APPLY AT MAXIMUM MATERIAL CONDITION (MMC)

7 x 64 Brenneke V&P Test Barrel

Issued: 07/28/1993

Revised: 08/16/2015

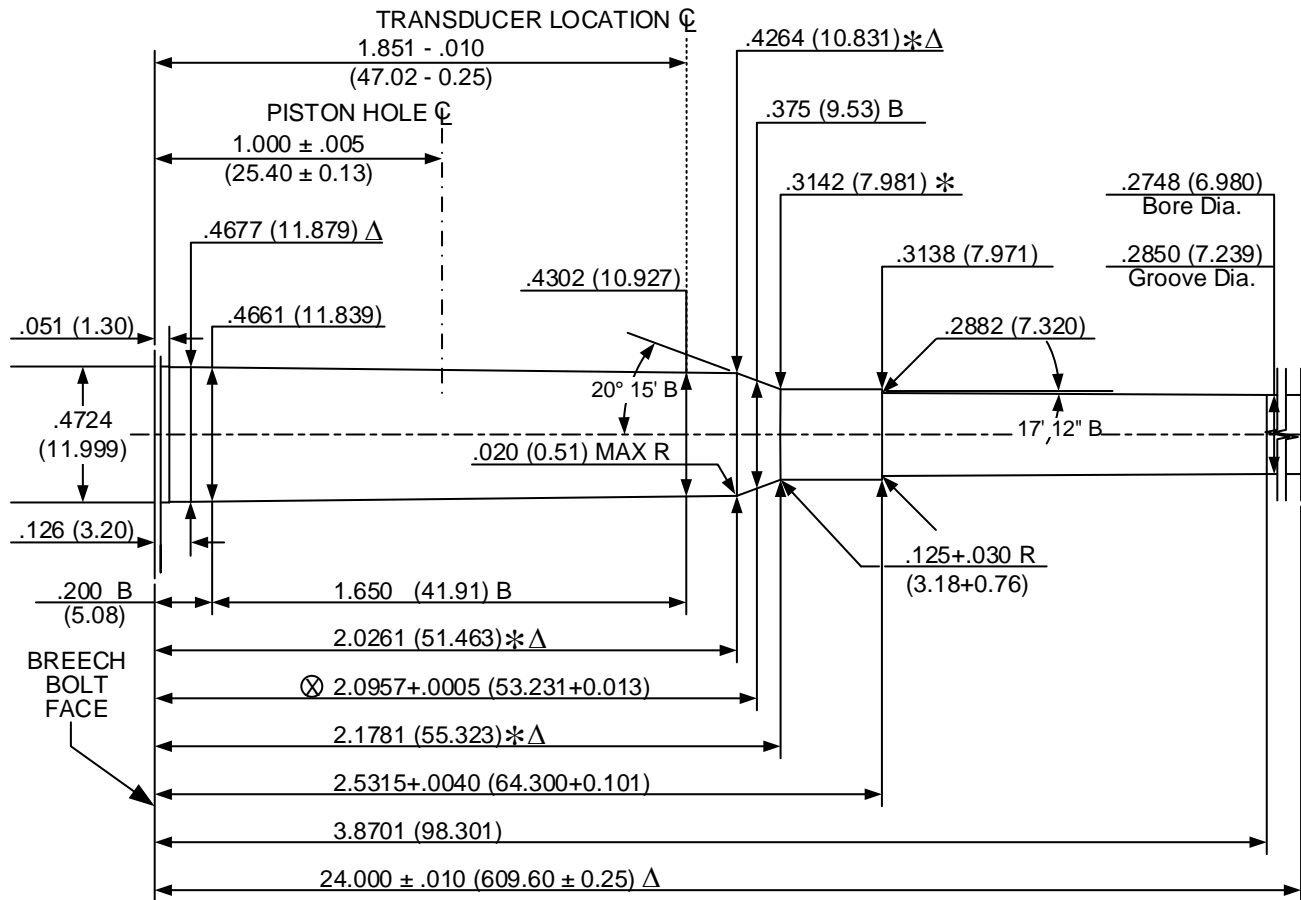

DO NOT SCALE FROM DRAWING

NUMBER OF GROOVES: 4
 WIDTH OF GROOVES: .146 + .002 (9.71 + 0.05)
 TWIST RATE: 8.661 (219.99) R.H.
 DIAMETER OF PISTON HOLE: .206 (5.23)
 TRANSDUCER DIAMETER: .250 (6.35)

LAND AND GROOVE DIMENSIONS TO BE
 WITHIN TOLERANCES THROUGHOUT
 LENGTH OF BARREL.

UNLESS OTHERWISE NOTED,
 ALL DIAMETERS +.0005 (0.013)
 LENGTH TOLERANCE + .005 (0.13)

NOTE:

B = BASIC Δ = REFERENCE DIMENSION ⊗ = HEADSPACE DIMENSION
 * DIMENSIONS ARE TO INTERSECTIONS OF LINES (XX.XX) = MILLIMETERS
 ALL CALCULATIONS APPLY AT MAXIMUM MATERIAL CONDITION (MMC)

7-30 Waters V&P Test Barrel

Issued: 03/26/1985

Revised: 08/16/2015

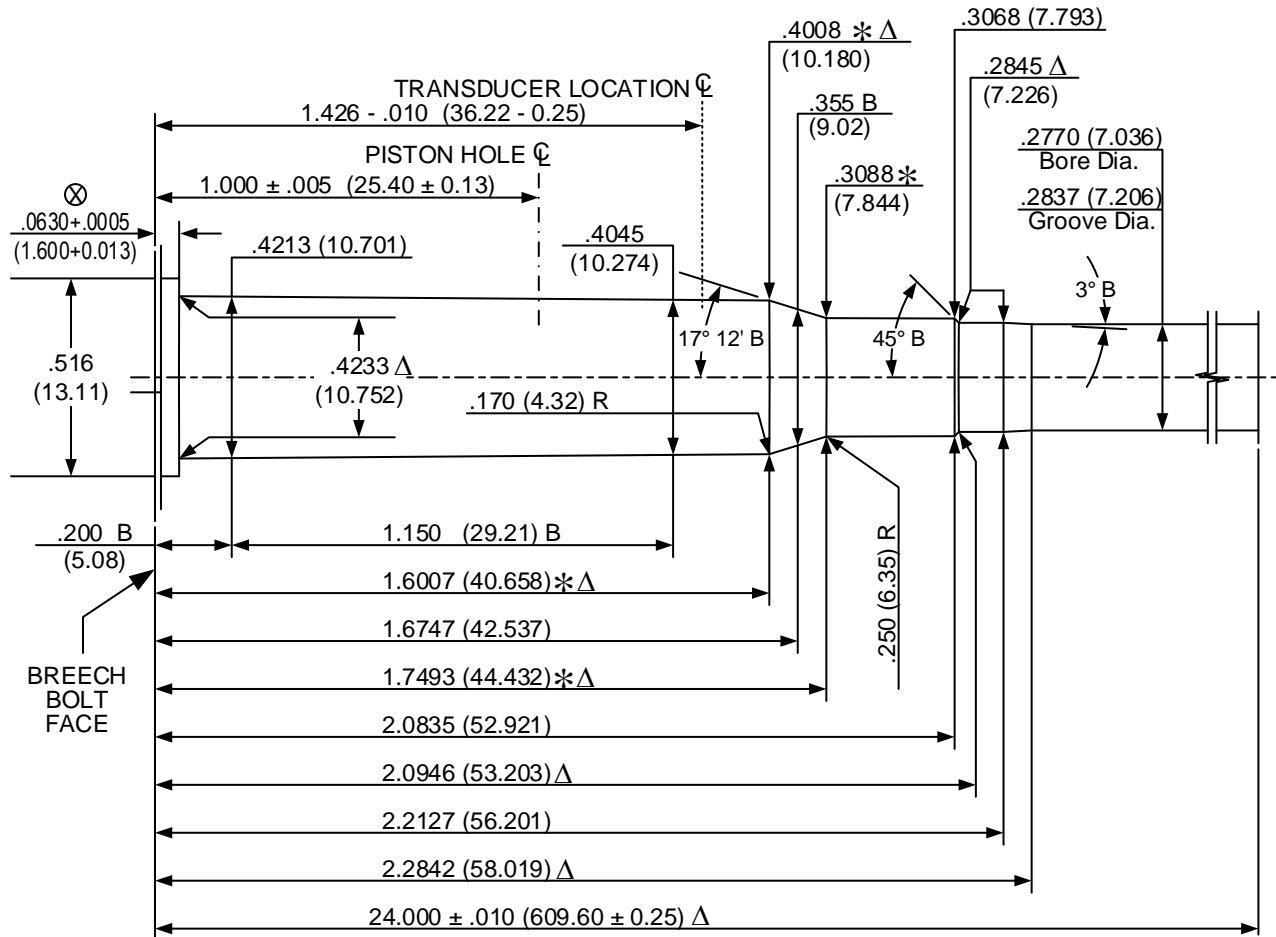

DO NOT SCALE FROM DRAWING

- NUMBER OF GROOVES: 6
- WIDTH OF GROOVES: .110 + .002 (2.79 + 0.05)
- TWIST RATE: 9.50 (241.3) R.H.
- DIAMETER OF PISTON HOLE: .206 (5.23)
- TRANSDUCER DIAMETER: .250 (6.35)

LAND AND GROOVE DIMENSIONS TO BE WITHIN TOLERANCES THROUGHOUT LENGTH OF BARREL.

UNLESS OTHERWISE NOTED, ALL DIAMETERS +.0005 (0.013) LENGTH TOLERANCE + .005 (0.13)

NOTE:

- B = BASIC
- Δ = REFERENCE DIMENSION
- ⊗ = HEADSPACE DIMENSION
- * DIMENSIONS ARE TO INTERSECTIONS OF LINES
- (XX.XX) = MILLIMETERS
- ALL CALCULATIONS APPLY AT MAXIMUM MATERIAL CONDITION (MMC)

7.62 x 39 V&P Test Barrel

Issued: 08/01/1988

Revised: 08/16/2015

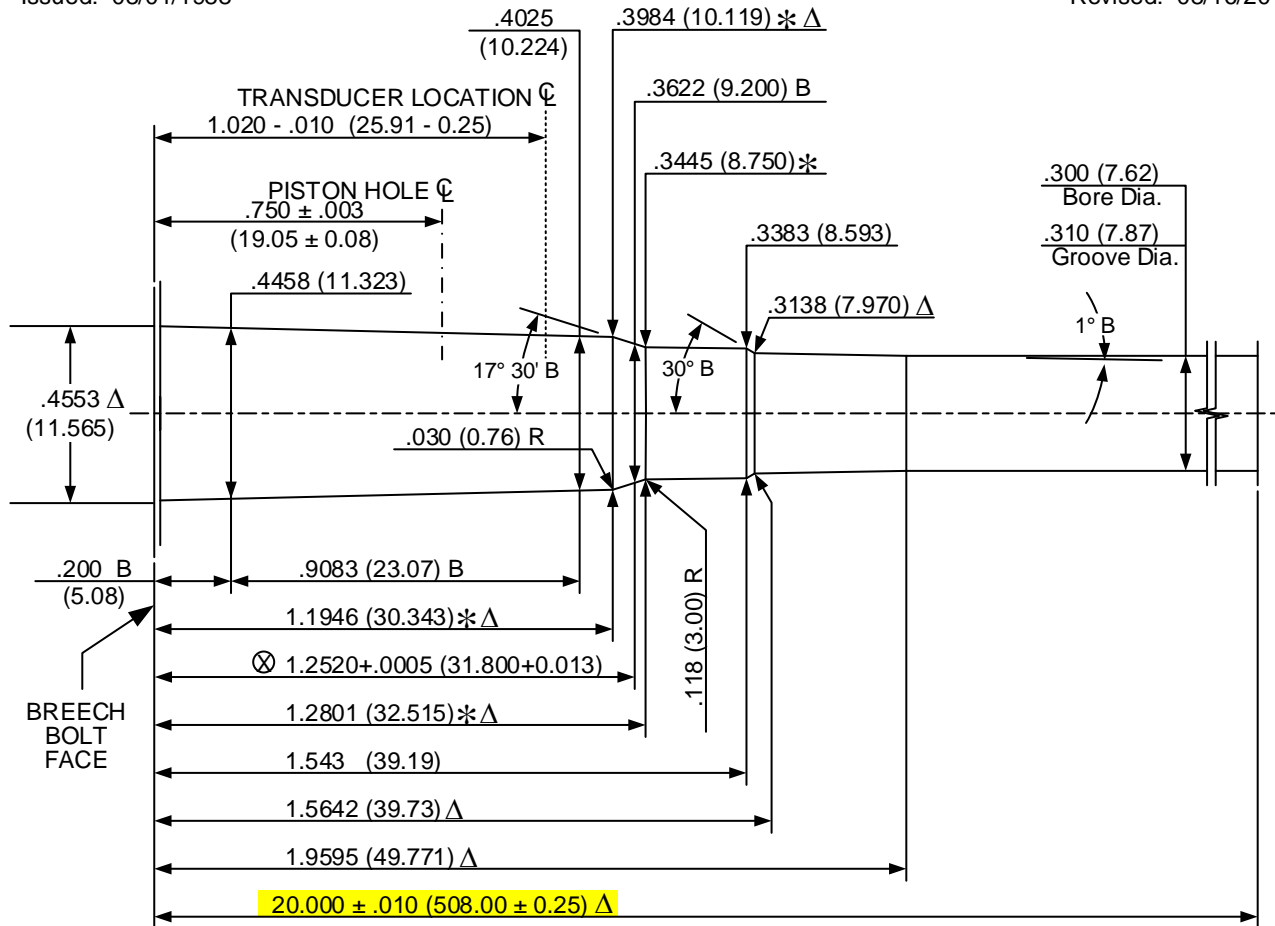

DO NOT SCALE FROM DRAWING

- NUMBER OF GROOVES: 4
- WIDTH OF GROOVES: .150 + .002 (3.81 + 0.05)
- TWIST RATE: 9.45 (240.0) R.H.
- DIAMETER OF PISTON HOLE: .206 (5.23)
- TRANSDUCER DIAMETER: .250 (6.35)

LAND AND GROOVE DIMENSIONS TO BE WITHIN TOLERANCES THROUGHOUT LENGTH OF BARREL.

UNLESS OTHERWISE NOTED, ALL DIAMETERS +.0005 (0.013) LENGTH TOLERANCE + .005 (0.13)

NOTE:

- B = BASIC
- Δ = REFERENCE DIMENSION
- \otimes = HEADSPACE DIMENSION
- * DIMENSIONS ARE TO INTERSECTIONS OF LINES
- (XX.XX) = MILLIMETERS
- ALL CALCULATIONS APPLY AT MAXIMUM MATERIAL CONDITION (MMC)

8mm Mauser (8 x 57) V&P Test Barrel

Issued: 05/20/1980

Revised: 08/16/2015

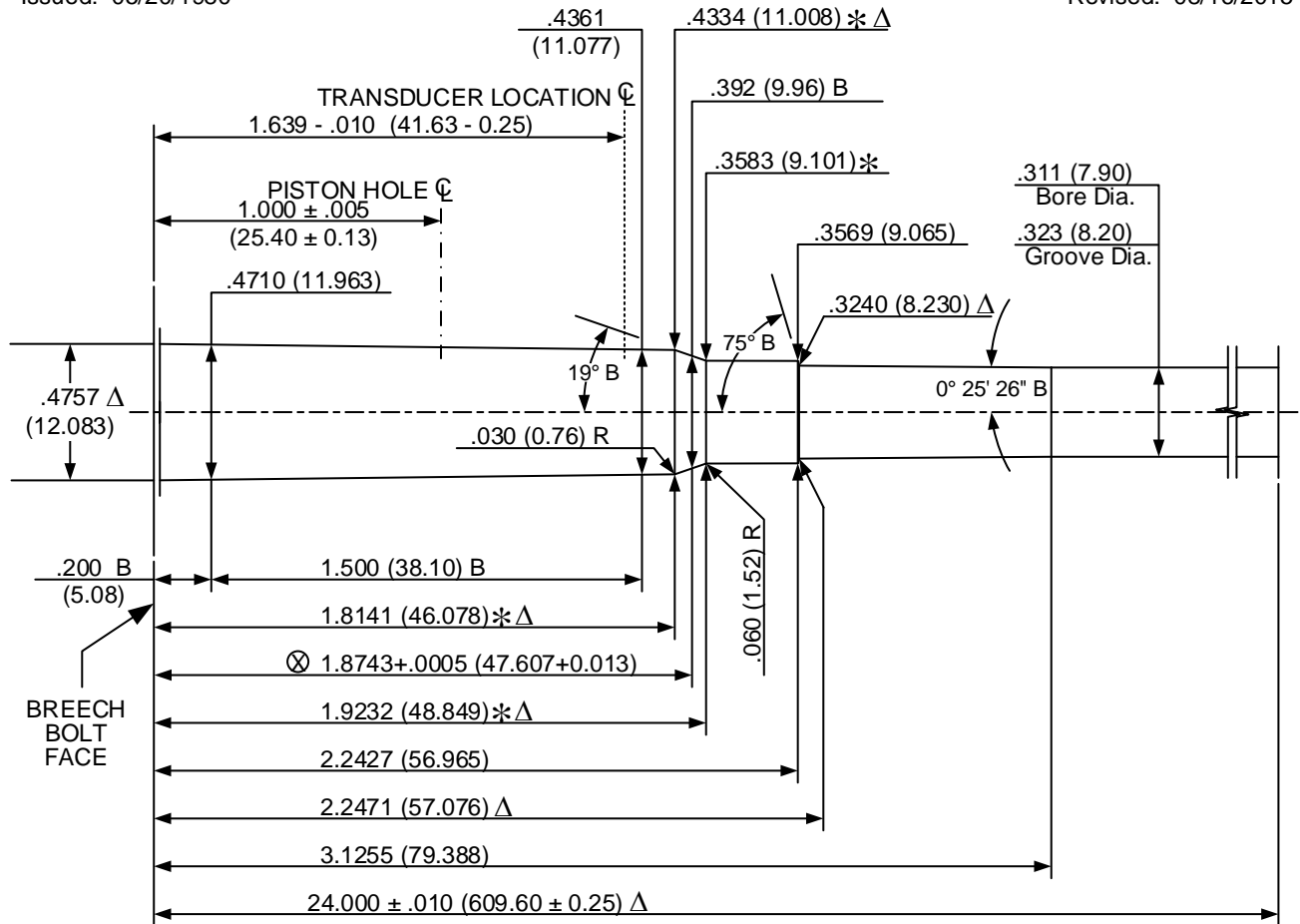

DO NOT SCALE FROM DRAWING

NUMBER OF GROOVES: 4
 WIDTH OF GROOVES: .176 + .002 (4.47 + 0.05)
 TWIST RATE: 9.5 (241.3) R.H.
 DIAMETER OF PISTON HOLE: .206 (5.23)
 TRANSDUCER DIAMETER: .250 (6.35)

LAND AND GROOVE DIMENSIONS TO BE
 WITHIN TOLERANCES THROUGHOUT
 LENGTH OF BARREL.

UNLESS OTHERWISE NOTED,
 ALL DIAMETERS +.0005 (0.013)
 LENGTH TOLERANCE + .005 (0.13)

NOTE:

B = BASIC Δ = REFERENCE DIMENSION ⊗ = HEADSPACE DIMENSION
 * DIMENSIONS ARE TO INTERSECTIONS OF LINES (XX.XX) = MILLIMETERS
 ALL CALCULATIONS APPLY AT MAXIMUM MATERIAL CONDITION (MMC)

8mm Remington Magnum V&P Test Barrel

Issued: 05/20/1980

Revised: 12/30/2004

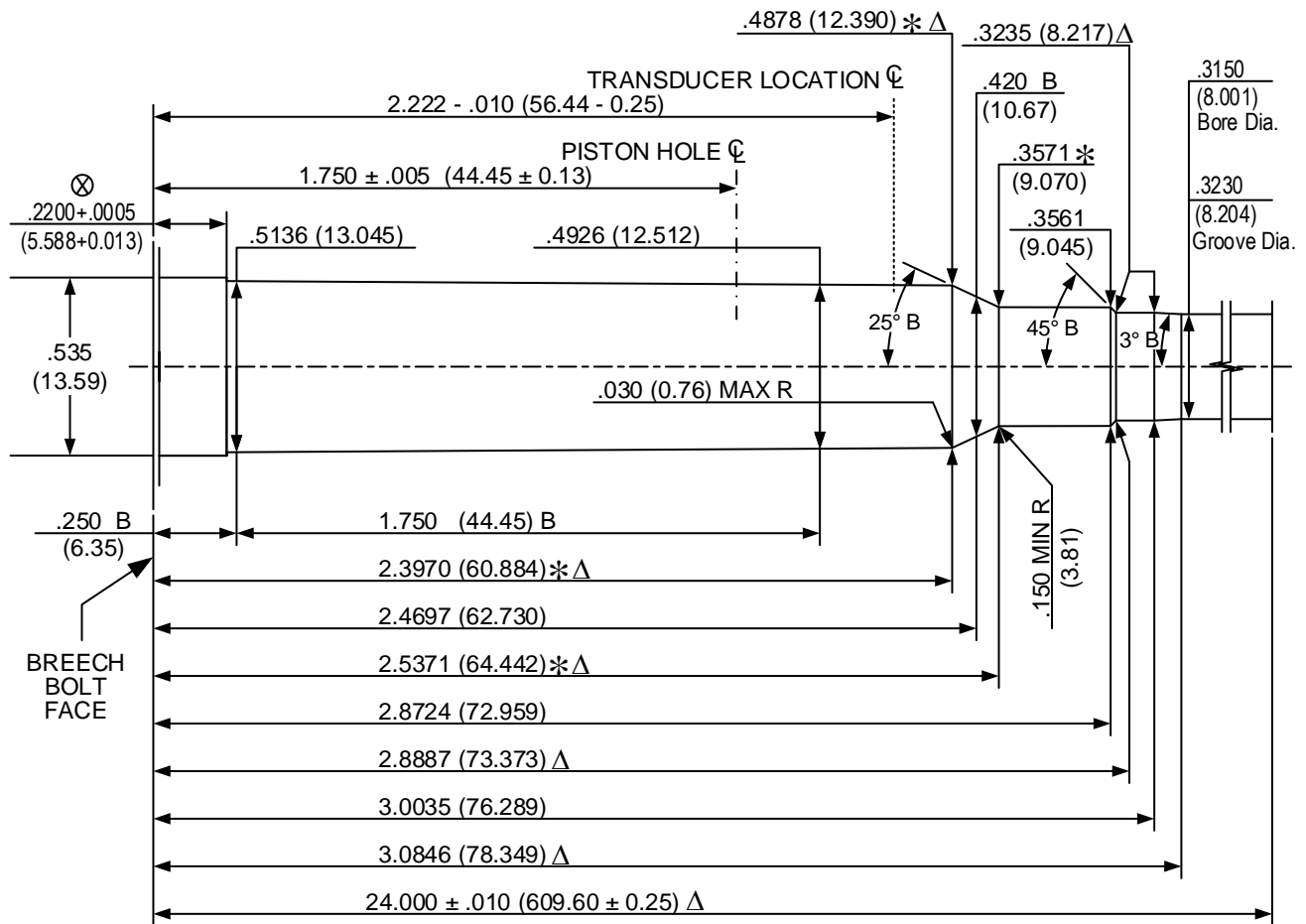

DO NOT SCALE FROM DRAWING

- NUMBER OF GROOVES: 6
- WIDTH OF GROOVES: $.122 + .005$ (3.10 + 0.13)
- TWIST RATE: 10.00 (254.0) R.H.
- DIAMETER OF PISTON HOLE: $.206$ (5.23)
- TRANSDUCER DIAMETER: $.250$ (6.35)

LAND AND GROOVE DIMENSIONS TO BE WITHIN TOLERANCES THROUGHOUT LENGTH OF BARREL.

UNLESS OTHERWISE NOTED, ALL DIAMETERS $+.0005$ (0.013) LENGTH TOLERANCE $+.005$ (0.13)

NOTE:

- B = BASIC
- Δ = REFERENCE DIMENSION
- ⊗ = HEADSPACE DIMENSION
- * DIMENSIONS ARE TO INTERSECTIONS OF LINES
- (XX.XX) = MILLIMETERS
- ALL CALCULATIONS APPLY AT MAXIMUM MATERIAL CONDITION (MMC)

9.3 x 62 V&P Test Barrel

Issued: 01/14/2013

Revised: 08/16/2015

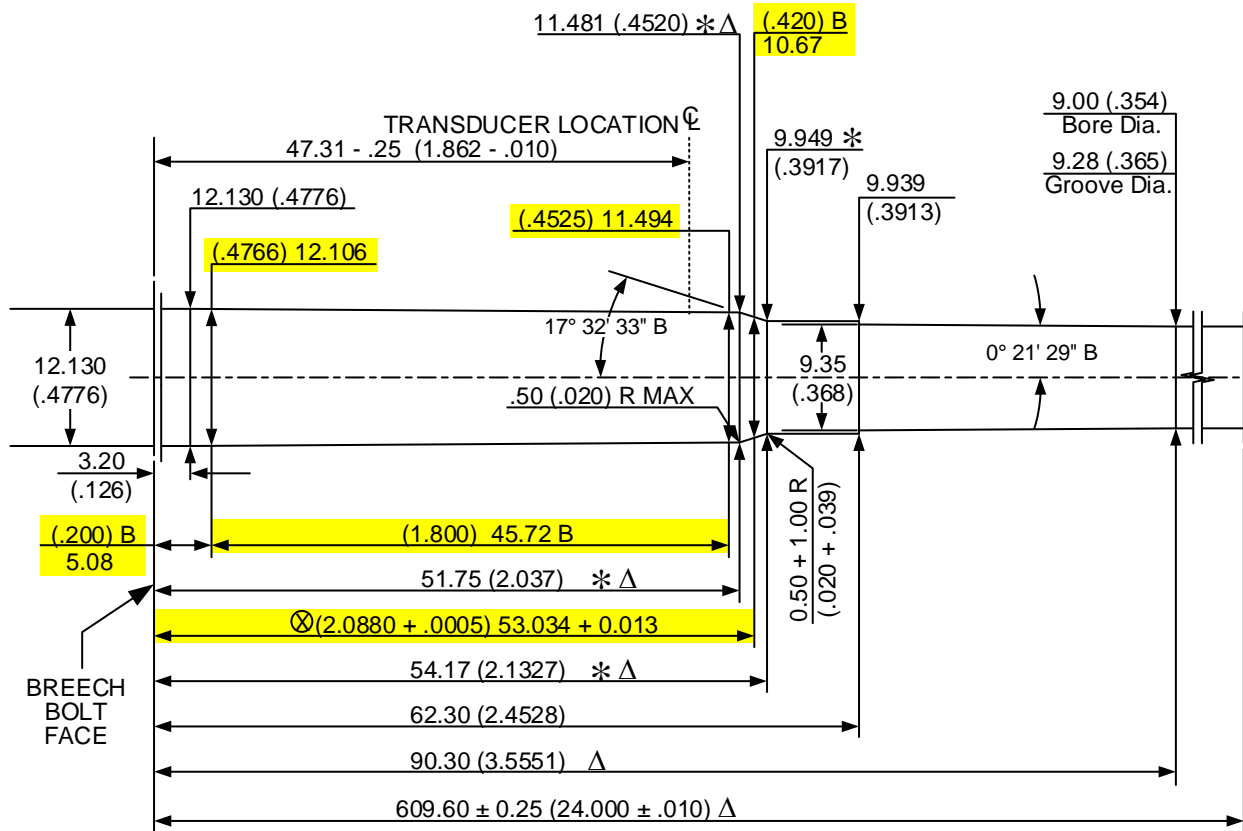

DO NOT SCALE FROM DRAWING

HIGHLIGHTED DIMENSIONS HAVE NO CORRESPONDING C.I.P. ANALOG. THE ENGLISH UNITS FOR THESE ARE THE ORIGINAL VALUES; METRIC VALUES ARE CALCULATED AND ROUNDED.

- NUMBER OF GROOVES: 4
- WIDTH OF GROOVES: 4.60 + .05 (.181 + 0.002)
- TWIST RATE: 360.0 (14.17) R.H.
- BARREL LENGTH: 609.60 ± 0.25 (24.000 ± .010)
- DIAMETER OF PISTON HOLE: Crusher pressure not established.
- TRANSDUCER DIAMETER: 6.35 (.250)

LAND AND GROOVE DIMENSIONS TO BE WITHIN TOLERANCES THROUGHOUT LENGTH OF BARREL.

UNLESS OTHERWISE NOTED, ALL DIAMETERS +0.013 (.0005) LENGTH TOLERANCE + 0.13 (.005)

NOTE:

- B = BASIC
- Δ = REFERENCE DIMENSION
- ⊗ = HEADSPACE DIMENSION
- * DIMENSIONS ARE TO INTERSECTIONS OF LINES
- (XX.XXXX) = INCHES
- ALL CALCULATIONS APPLY AT MAXIMUM MATERIAL CONDITION (MMC)

METRIC

17 Remington V&P Test Barrel

Issued: 05/20/1980

Revised: 12/30/2004

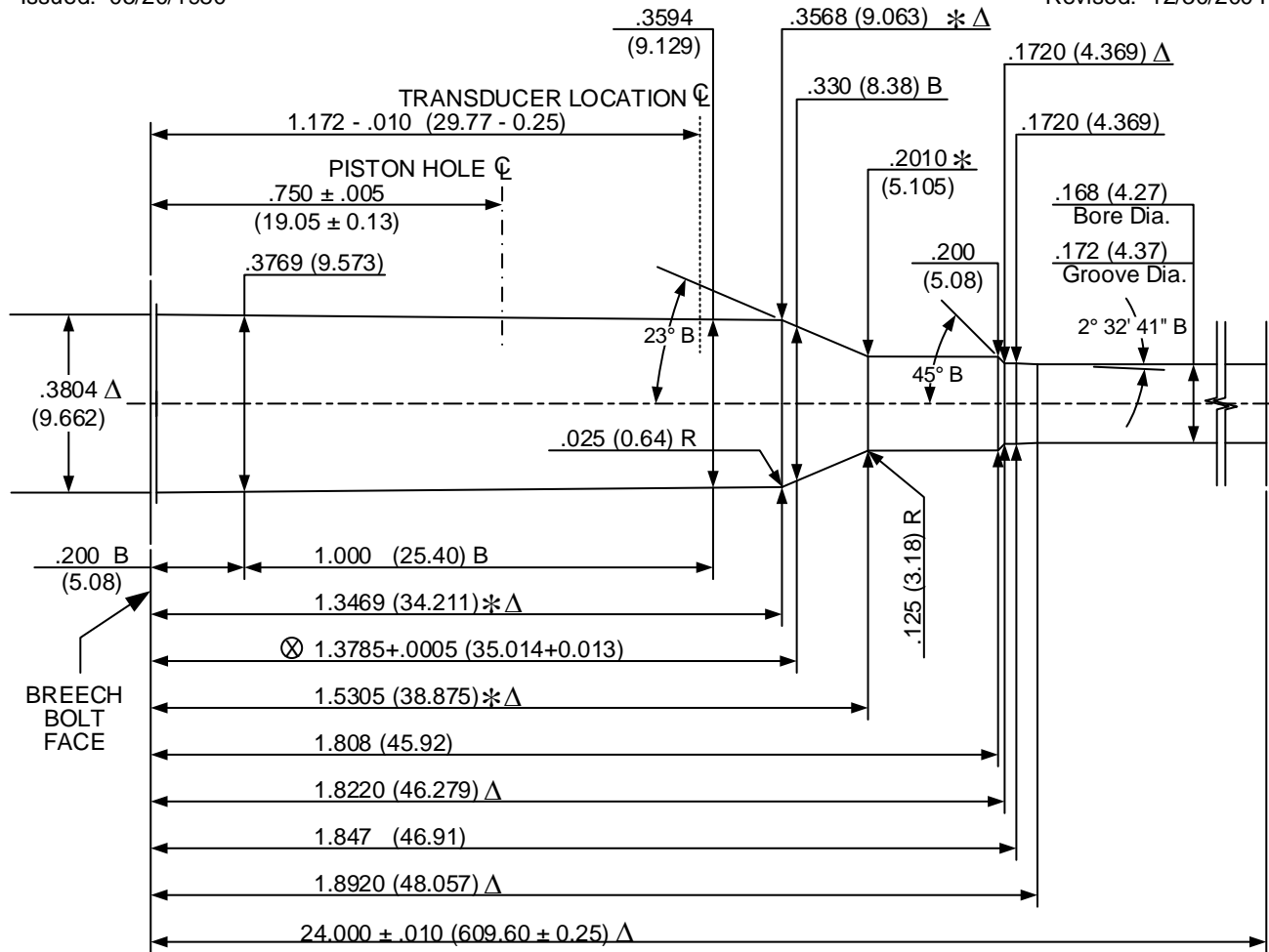

DO NOT SCALE FROM DRAWING

- NUMBER OF GROOVES: 6
- WIDTH OF GROOVES: .062 + .002 (1.57 + 0.05)
- TWIST RATE: 9.00 (228.6) R.H.
- DIAMETER OF PISTON HOLE: .206 (5.23)
- TRANSDUCER DIAMETER: .250 (6.35)

LAND AND GROOVE DIMENSIONS TO BE WITHIN TOLERANCES THROUGHOUT LENGTH OF BARREL.

UNLESS OTHERWISE NOTED, ALL DIAMETERS +.0005 (0.013) LENGTH TOLERANCE + .005 (0.13)

NOTE:

- B = BASIC
- Δ = REFERENCE DIMENSION
- ⊗ = HEADSPACE DIMENSION
- * DIMENSIONS ARE TO INTERSECTIONS OF LINES
- (XX.XX) = MILLIMETERS
- ALL CALCULATIONS APPLY AT MAXIMUM MATERIAL CONDITION (MMC)

17 Remington Fireball V&P Test Barrel

ISSUED: 01/04/2007

REVISED: 09/11/2007

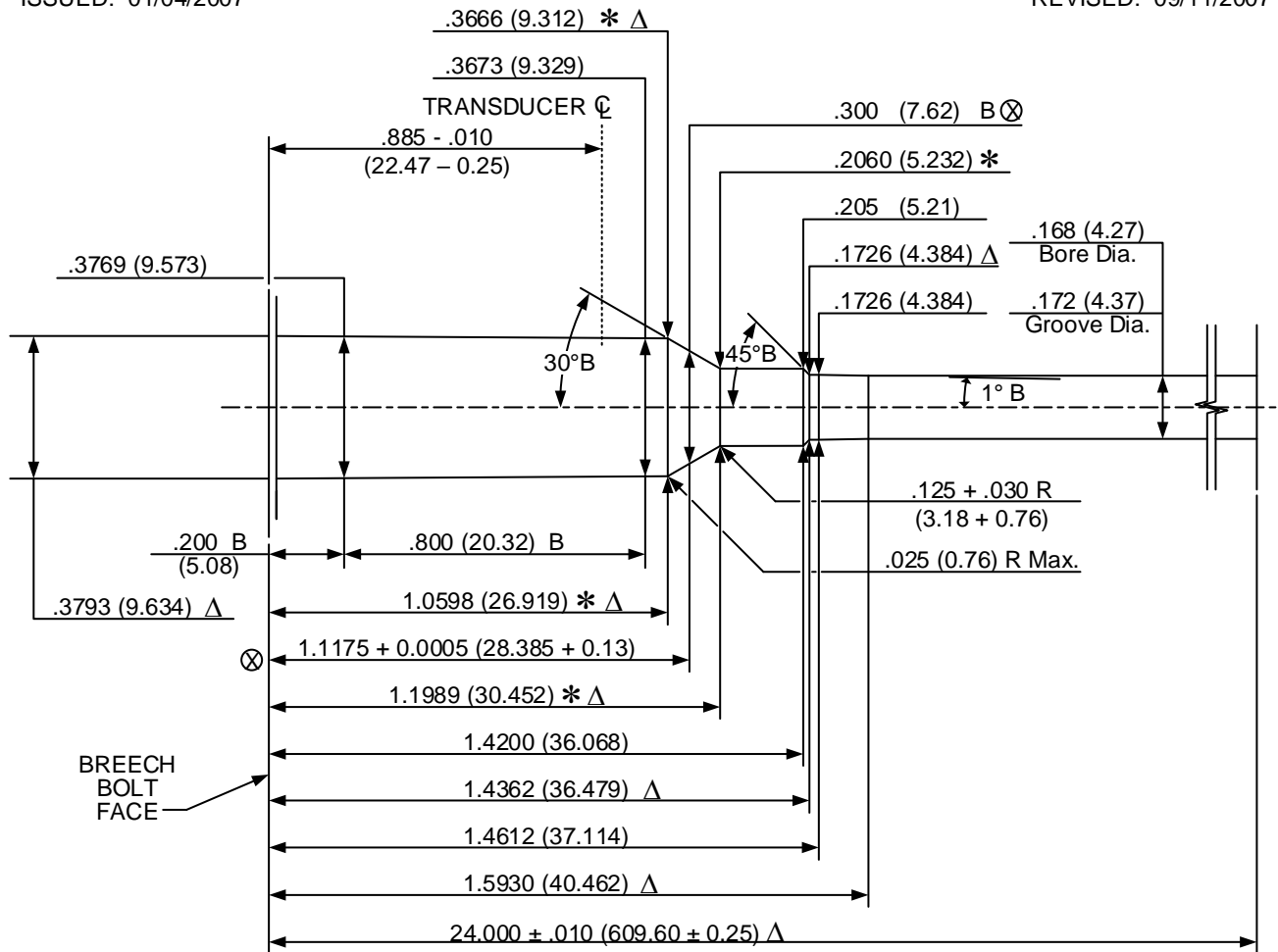

DO NOT SCALE FROM DRAWING

- NUMBER OF GROOVES: 6
- WIDTH OF GROOVES: .062 + .002 (1.57 + 0.05)
- TWIST RATE: 9.00 (228.6) R.H.
- DIAMETER OF PISTON HOLE: Crusher pressures not established.
- TRANSDUCER DIAMETER: .250 (6.35)

LAND AND GROOVE DIMENSIONS TO BE WITHIN TOLERANCES THROUGHOUT LENGTH OF BARREL.

UNLESS OTHERWISE NOTED, ALL DIAMETERS +.0005 (0.013) LENGTH TOLERANCE + .005 (0.13)

NOTE:

B = BASIC Δ = REFERENCE DIMENSION ⊗ = HEADSPACE DIMENSION
 * DIMENSIONS ARE TO INTERSECTIONS OF LINES (XX.XX) = MILLIMETERS
 ALL CALCULATIONS APPLY AT MAXIMUM MATERIAL CONDITION (MMC)

204 Ruger V&P Test Barrel

Issued: 06/12/2004

Revised: 12/31/2004

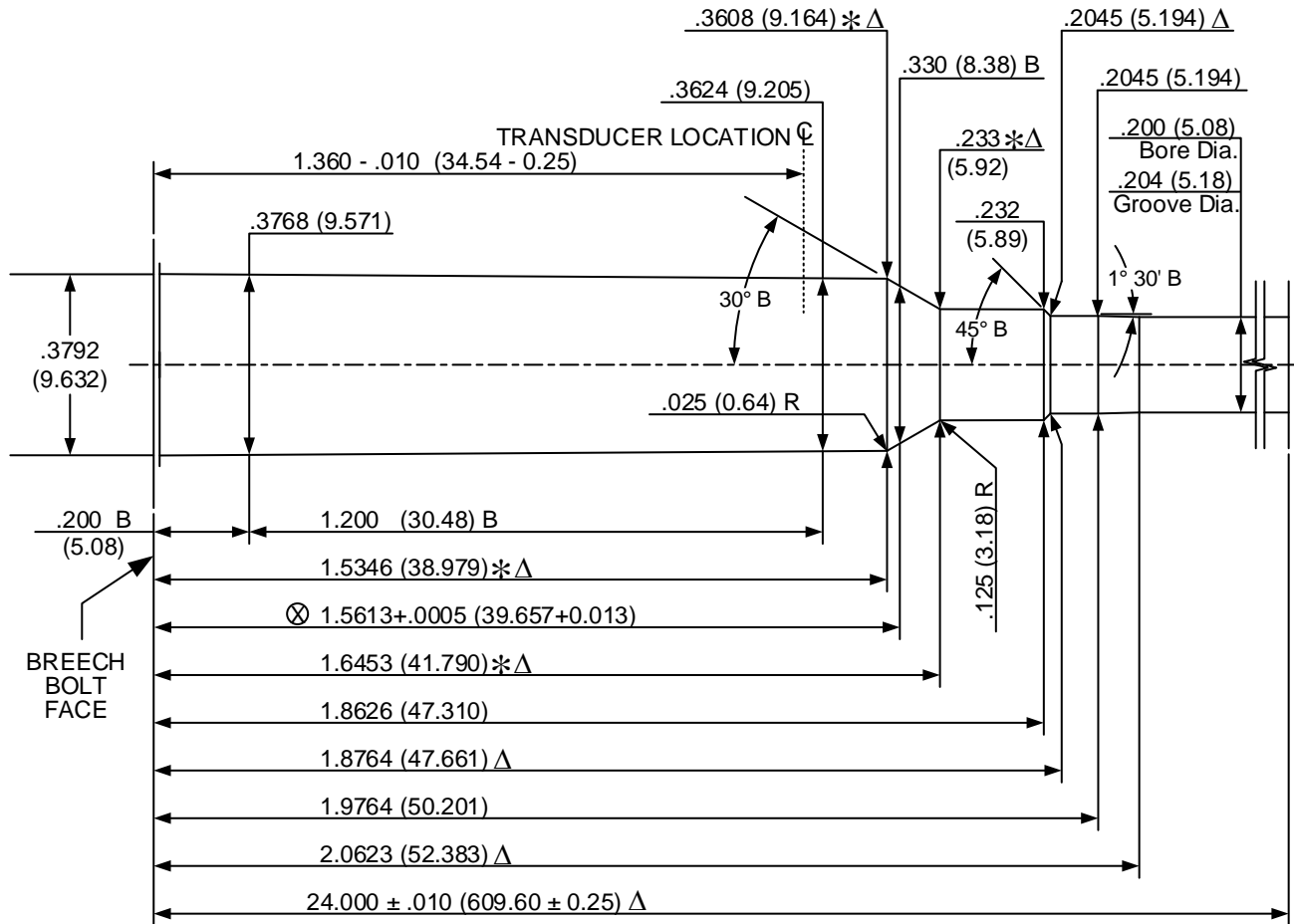

DO NOT SCALE FROM DRAWING

NUMBER OF GROOVES: 6
 WIDTH OF GROOVES: .054 + .002 (1.37 + 0.05)
 TWIST RATE: 12.00 (304.8) R.H.
 DIAMETER OF PISTON HOLE: Crusher pressures not established
 TRANSDUCER DIAMETER: .250 (6.35)

LAND AND GROOVE DIMENSIONS TO BE
 WITHIN TOLERANCES THROUGHOUT
 LENGTH OF BARREL.

UNLESS OTHERWISE NOTED,
 ALL DIAMETERS +.0005 (0.013)
 LENGTH TOLERANCE + .005 (0.13)

NOTE:

B = BASIC Δ = REFERENCE DIMENSION ⊗ = HEADSPACE DIMENSION
 * DIMENSIONS ARE TO INTERSECTIONS OF LINES (XX.XX) = MILLIMETERS
 ALL CALCULATIONS APPLY AT MAXIMUM MATERIAL CONDITION (MMC)

218 Bee V&P Test Barrel

Issued: 05/20/1980

Revised: 12/30/2004

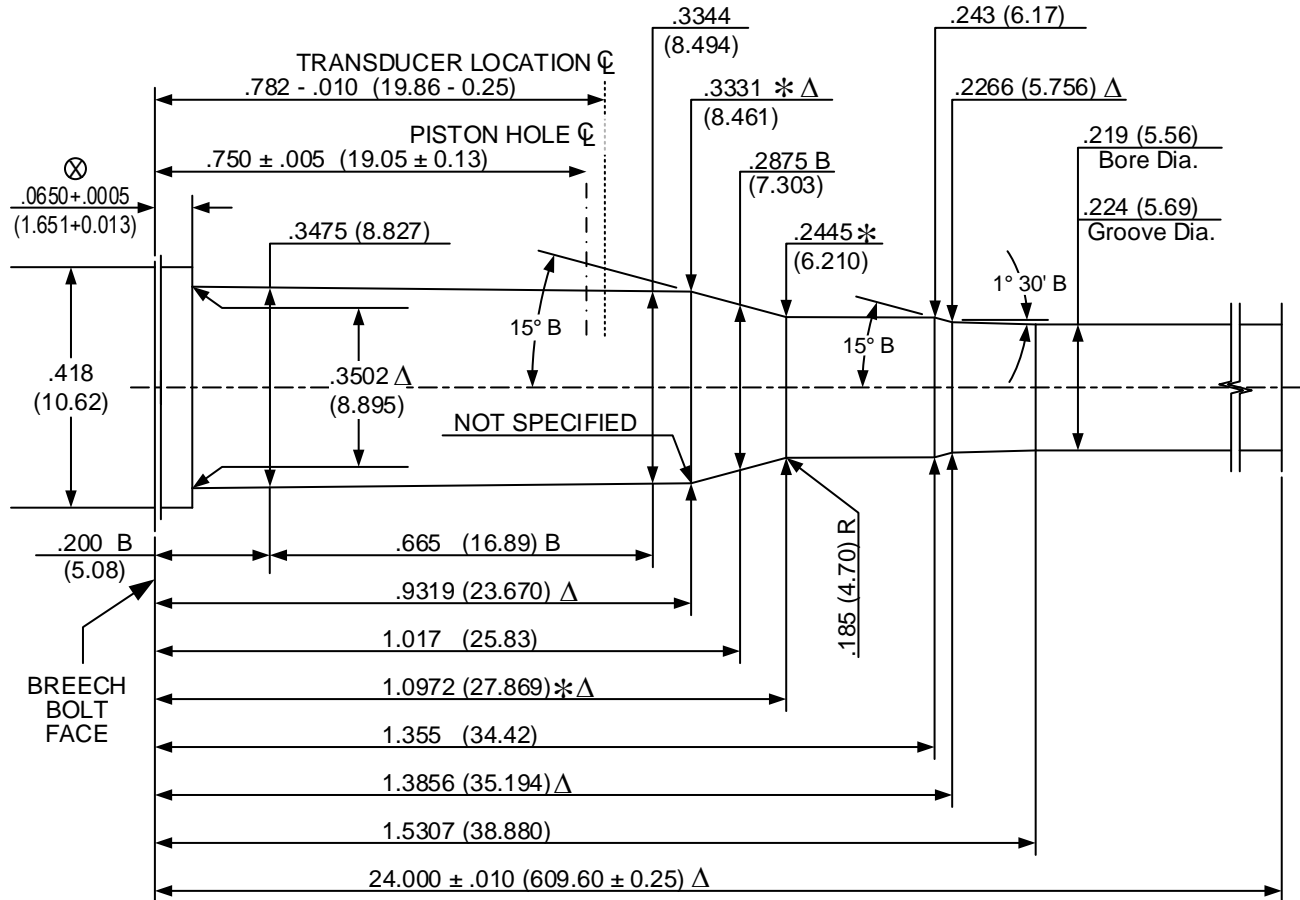

DO NOT SCALE FROM DRAWING

- NUMBER OF GROOVES: 6
- WIDTH OF GROOVES: .074 + .002 (1.88 + 0.05)
- TWIST RATE: 16.00 (406.4) R.H.
- DIAMETER OF PISTON HOLE: .206 (5.23)
- TRANSDUCER DIAMETER: .194 (4.93)**

LAND AND GROOVE DIMENSIONS TO BE WITHIN TOLERANCES THROUGHOUT LENGTH OF BARREL.

UNLESS OTHERWISE NOTED, ALL DIAMETERS +.0005 (0.013) LENGTH TOLERANCE + .005 (0.13)

NOTE:

- B = BASIC
- Δ = REFERENCE DIMENSION
- ⊗ = HEADSPACE DIMENSION
- * DIMENSIONS ARE TO INTERSECTIONS OF LINES
- (XX.XX) = MILLIMETERS
- ALL CALCULATIONS APPLY AT MAXIMUM MATERIAL CONDITION (MMC)

22 Hornet V&P Test Barrel

Issued: 05/20/1980

Revised: 12/30/2004

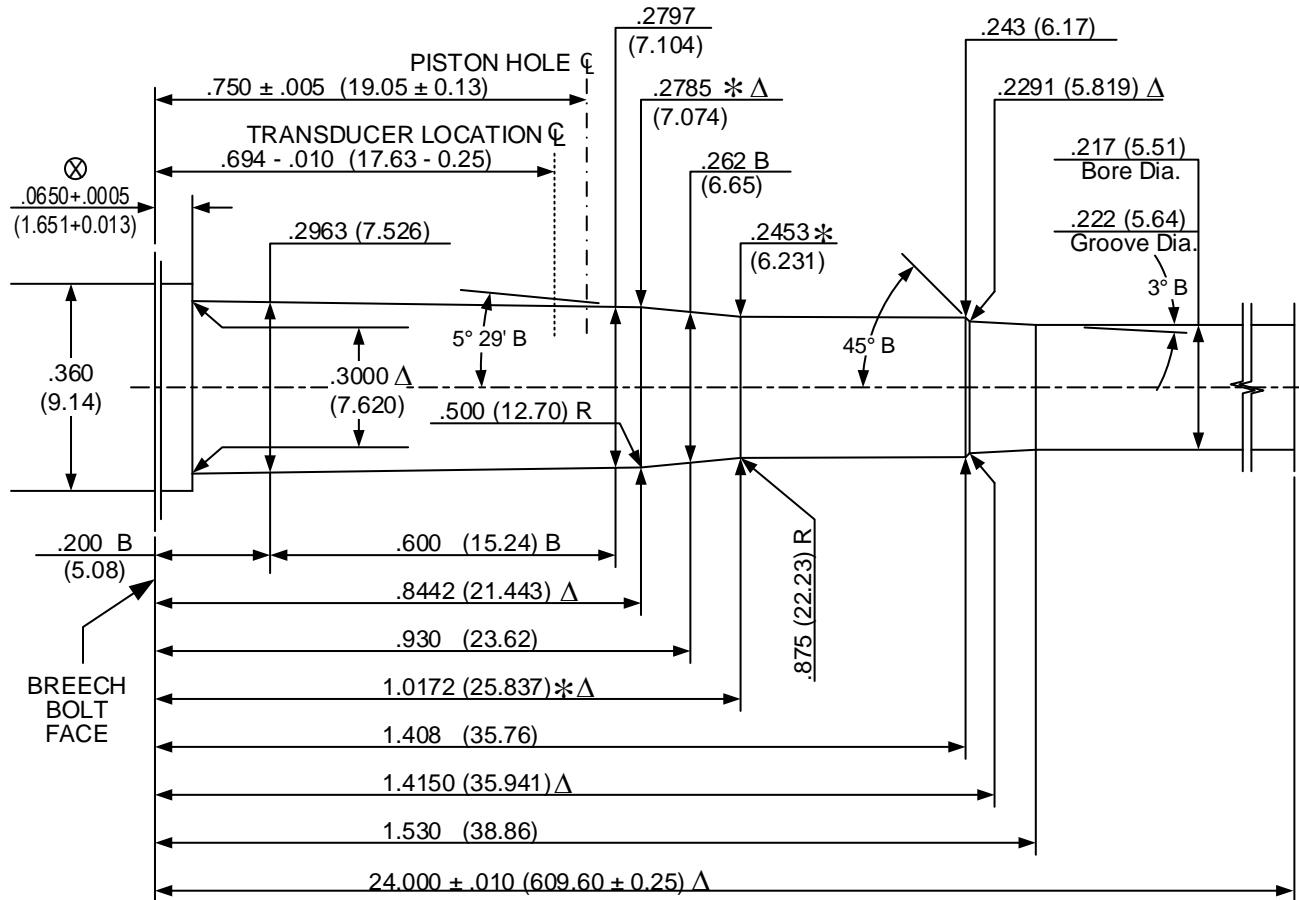

DO NOT SCALE FROM DRAWING

- NUMBER OF GROOVES: 6
- WIDTH OF GROOVES: .068 + .002 (1.73 + 0.05)
- TWIST RATE: 16.00 (406.4) R.H.
- DIAMETER OF PISTON HOLE: .206 (5.23)
- TRANSUDER DIAMETER: .194 (4.93)**

LAND AND GROOVE DIMENSIONS TO BE
 WITHIN TOLERANCES THROUGHOUT
 LENGTH OF BARREL.

UNLESS OTHERWISE NOTED,
 ALL DIAMETERS +.0005 (0.013)
 LENGTH TOLERANCE + .005 (0.13)

NOTE:

- B = BASIC
- Δ = REFERENCE DIMENSION
- ⊗ = HEADSPACE DIMENSION
- * DIMENSIONS ARE TO INTERSECTIONS OF LINES
- (XX.XX) = MILLIMETERS
- ALL CALCULATIONS APPLY AT MAXIMUM MATERIAL CONDITION (MMC)

22-250 Remington V&P Test Barrel

Issued: 05/20/1980

Revised: 12/31/2004

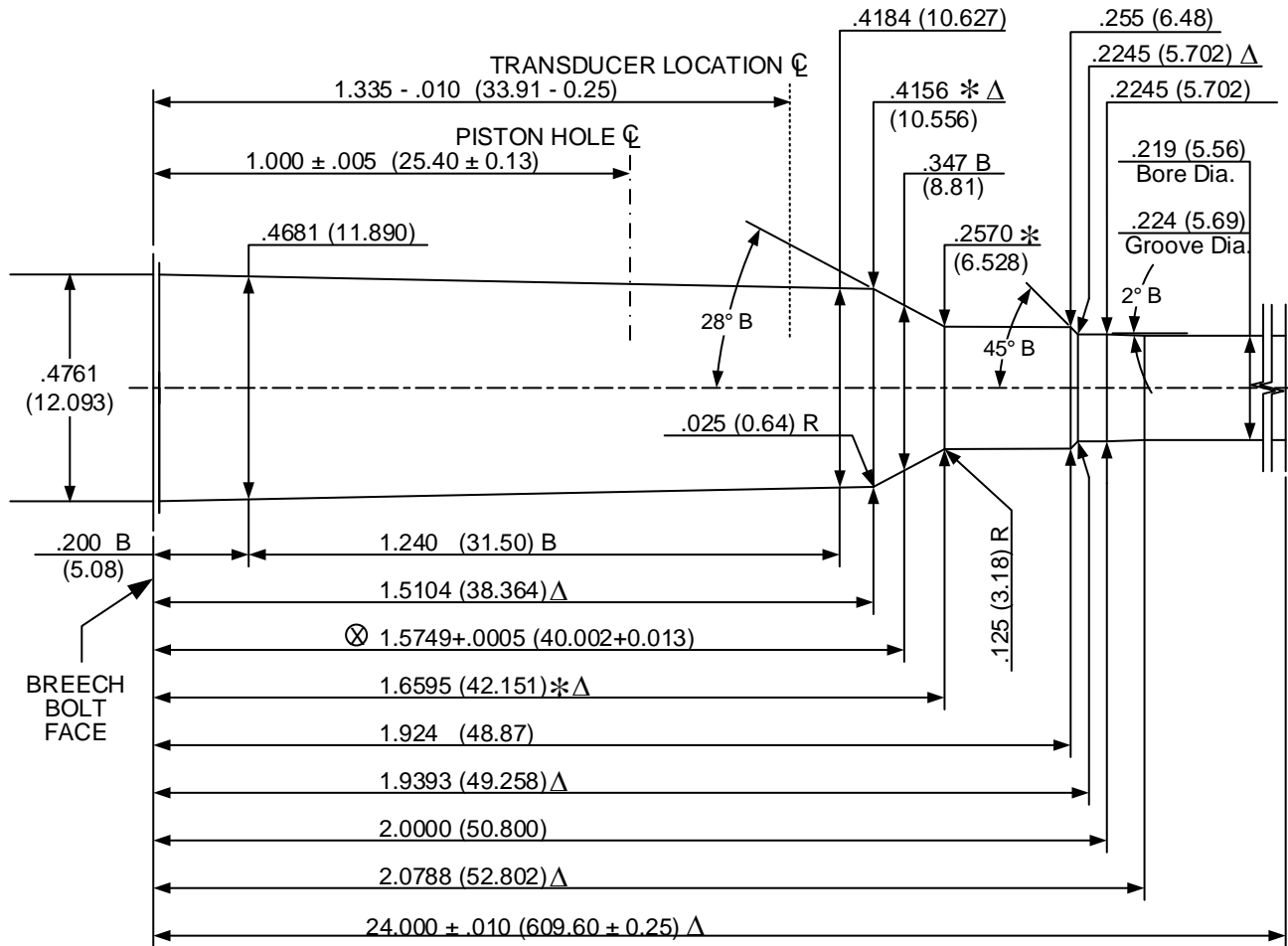

DO NOT SCALE FROM DRAWING

NUMBER OF GROOVES: 6
 WIDTH OF GROOVES: .080 + .002 (2.03 + 0.05)
 TWIST RATE: 14.00 (355.6) R.H.
 DIAMETER OF PISTON HOLE: .206 (5.23)
 TRANSDUCER DIAMETER: .250 (6.35)

LAND AND GROOVE DIMENSIONS TO BE
 WITHIN TOLERANCES THROUGHOUT
 LENGTH OF BARREL.

UNLESS OTHERWISE NOTED,
 ALL DIAMETERS +.0005 (0.013)
 LENGTH TOLERANCE + .005 (0.13)

NOTE:

B = BASIC Δ = REFERENCE DIMENSION ⊗ = HEADSPACE DIMENSION
 * DIMENSIONS ARE TO INTERSECTIONS OF LINES (XX.XX) = MILLIMETERS
 ALL CALCULATIONS APPLY AT MAXIMUM MATERIAL CONDITION (MMC)

220 Swift V&P Test Barrel

Issued: 05/20/1980

Revised: 12/30/2004

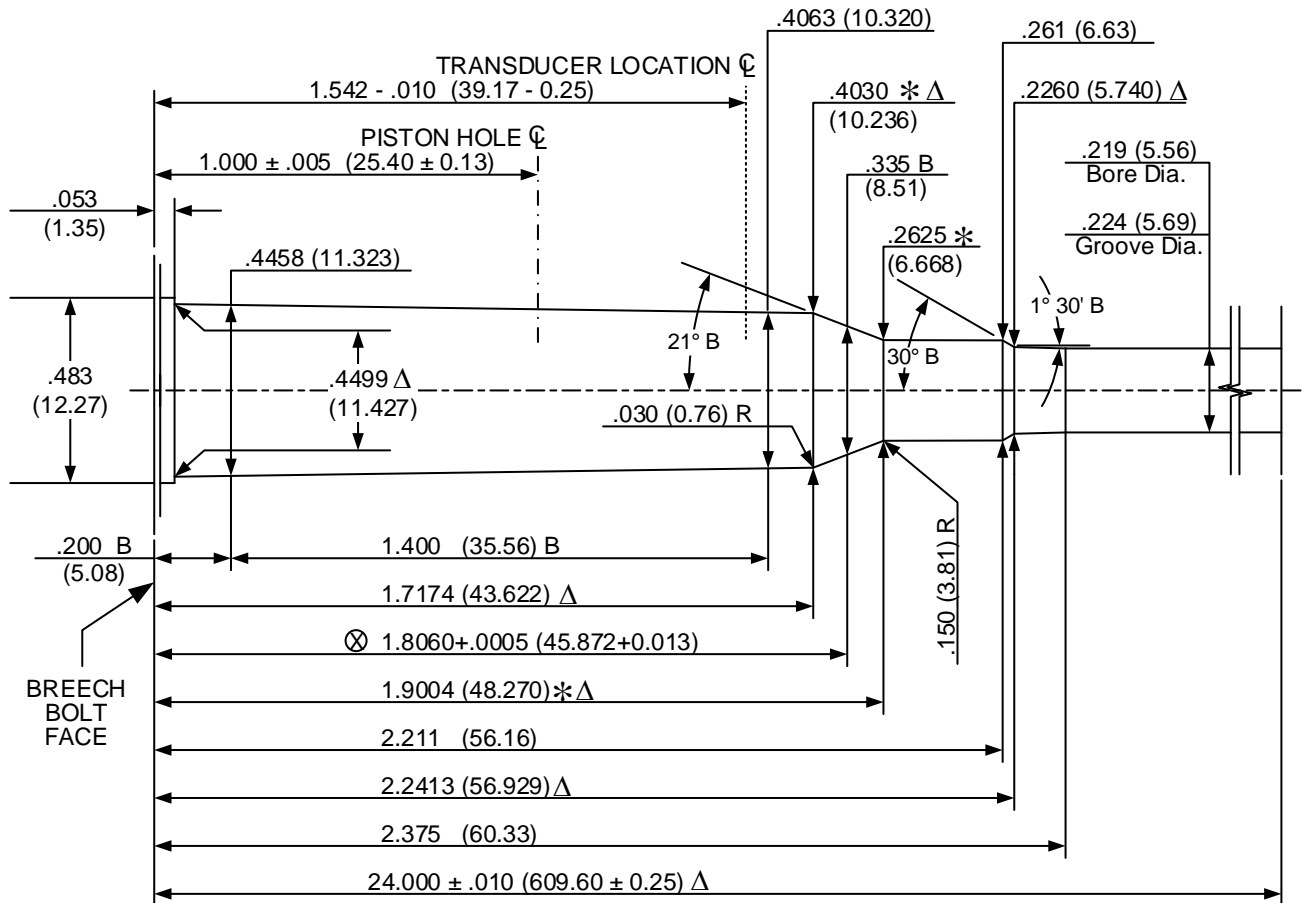

DO NOT SCALE FROM DRAWING

- NUMBER OF GROOVES: 6
- WIDTH OF GROOVES: .074 + .002 (1.88 + 0.05)
- TWIST RATE: 14.00 (355.6) R.H.
- DIAMETER OF PISTON HOLE: .206 (5.23)
- TRANSDUCER DIAMETER: .250 (6.35)

LAND AND GROOVE DIMENSIONS TO BE WITHIN TOLERANCES THROUGHOUT LENGTH OF BARREL.

UNLESS OTHERWISE NOTED, ALL DIAMETERS +.0005 (0.013) LENGTH TOLERANCE + .005 (0.13)

NOTE:

- B = BASIC
- Δ = REFERENCE DIMENSION
- ⊗ = HEADSPACE DIMENSION
- * DIMENSIONS ARE TO INTERSECTIONS OF LINES
- (XX.XX) = MILLIMETERS
- ALL CALCULATIONS APPLY AT MAXIMUM MATERIAL CONDITION (MMC)

221 Remington Fireball (Rifle) V&P Test Barrel

ISSUED: 01/16/2005

REVISED: - - / - - / - - - -

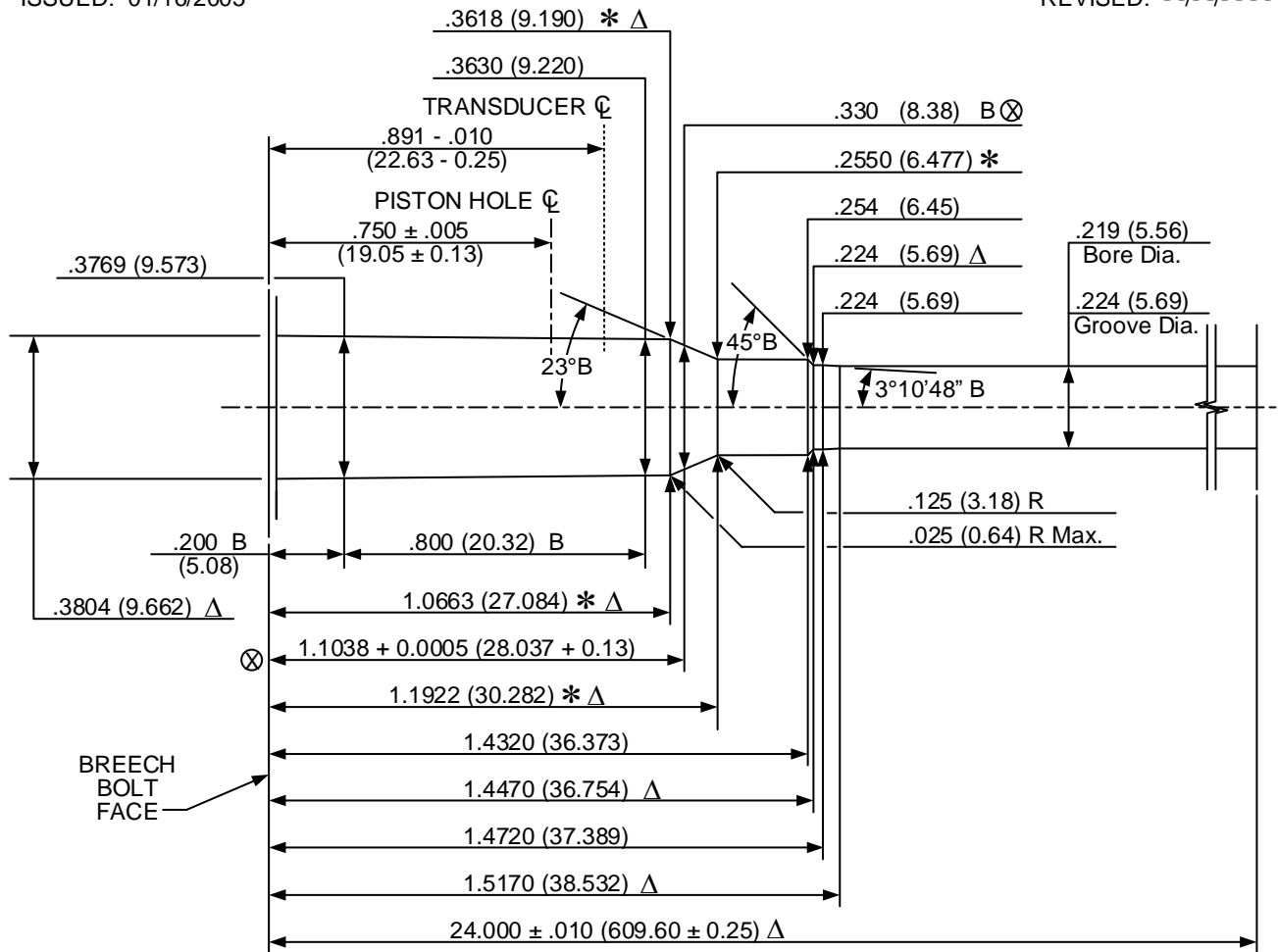

DO NOT SCALE FROM DRAWING

NUMBER OF GROOVES: 6
 WIDTH OF GROOVES: $.080 + .002$ (2.03 + 0.05)
 TWIST RATE: 14.00 (355.6) R.H.
 DIAMETER OF PISTON HOLE: $.206$ (5.23)
 TRANSDUCER DIAMETER: $.250$ (6.35)

RIFLE

LAND AND GROOVE DIMENSIONS TO BE WITHIN TOLERANCES THROUGHOUT LENGTH OF BARREL.

UNLESS OTHERWISE NOTED, ALL DIAMETERS $+.0005$ (0.013) LENGTH TOLERANCE $+.005$ (0.13)

NOTE:
 B = BASIC Δ = REFERENCE DIMENSION \otimes = HEADSPACE DIMENSION
 * DIMENSIONS ARE TO INTERSECTIONS OF LINES (XX.XX) = MILLIMETERS
 ALL CALCULATIONS APPLY AT MAXIMUM MATERIAL CONDITION (MMC)

222 Remington V&P Test Barrel

Issued: 05/20/1980

Revised: 12/31/2004

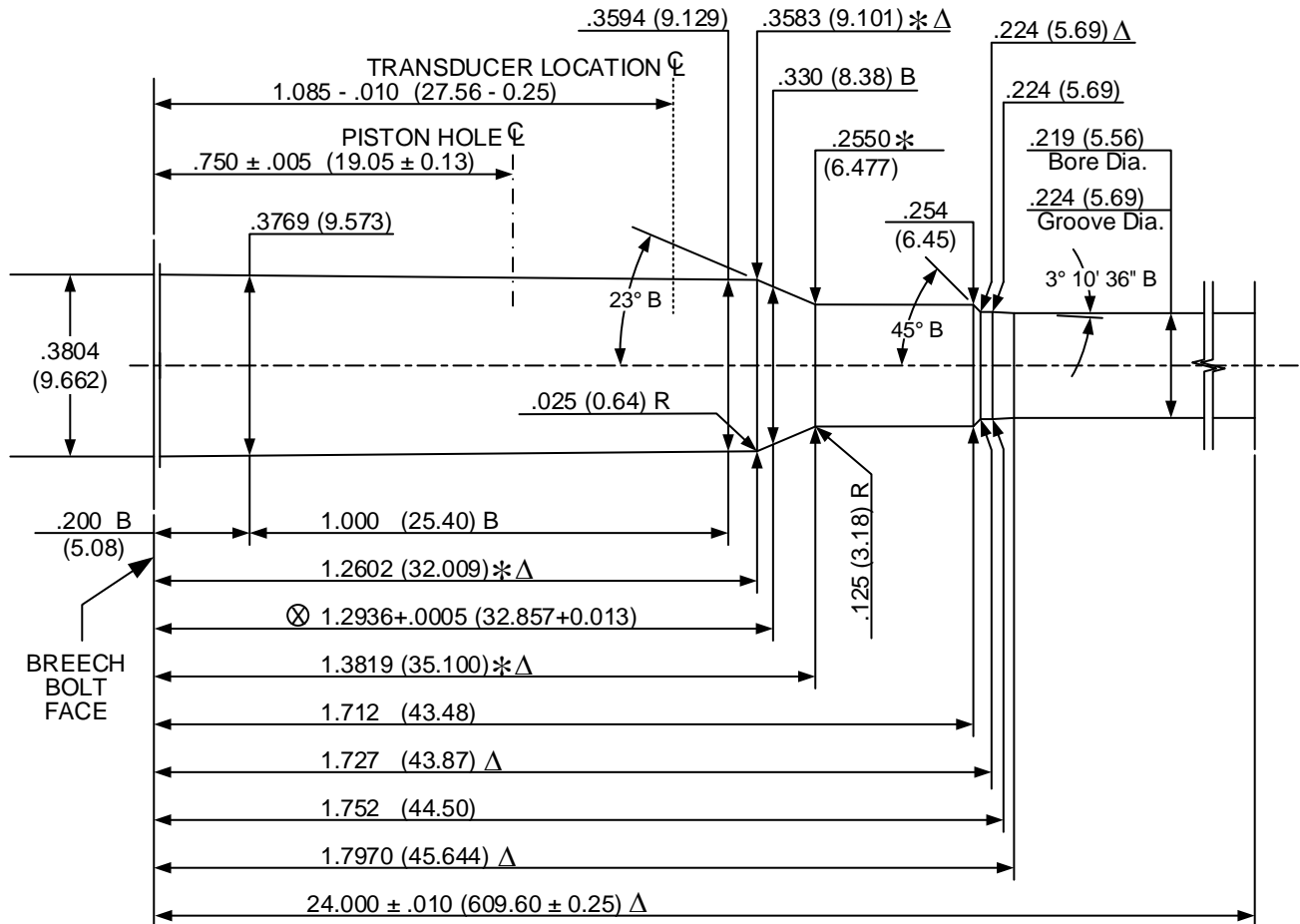

DO NOT SCALE FROM DRAWING

- NUMBER OF GROOVES: 6
- WIDTH OF GROOVES: .080 + .002 (2.03 + 0.05)
- TWIST RATE: 14.00 (355.6) R.H.
- DIAMETER OF PISTON HOLE: .206 (5.23)
- TRANSDUCER DIAMETER: .250 (6.35)

LAND AND GROOVE DIMENSIONS TO BE WITHIN TOLERANCES THROUGHOUT LENGTH OF BARREL.

UNLESS OTHERWISE NOTED, ALL DIAMETERS +.0005 (0.013) LENGTH TOLERANCE + .005 (0.13)

NOTE:

- B = BASIC
- Δ = REFERENCE DIMENSION
- ⊗ = HEADSPACE DIMENSION
- * DIMENSIONS ARE TO INTERSECTIONS OF LINES
- (XX.XX) = MILLIMETERS
- ALL CALCULATIONS APPLY AT MAXIMUM MATERIAL CONDITION (MMC)

222 Remington Magnum V&P Test Barrel

Issued: 05/20/1980

Revised: 12/31/2004

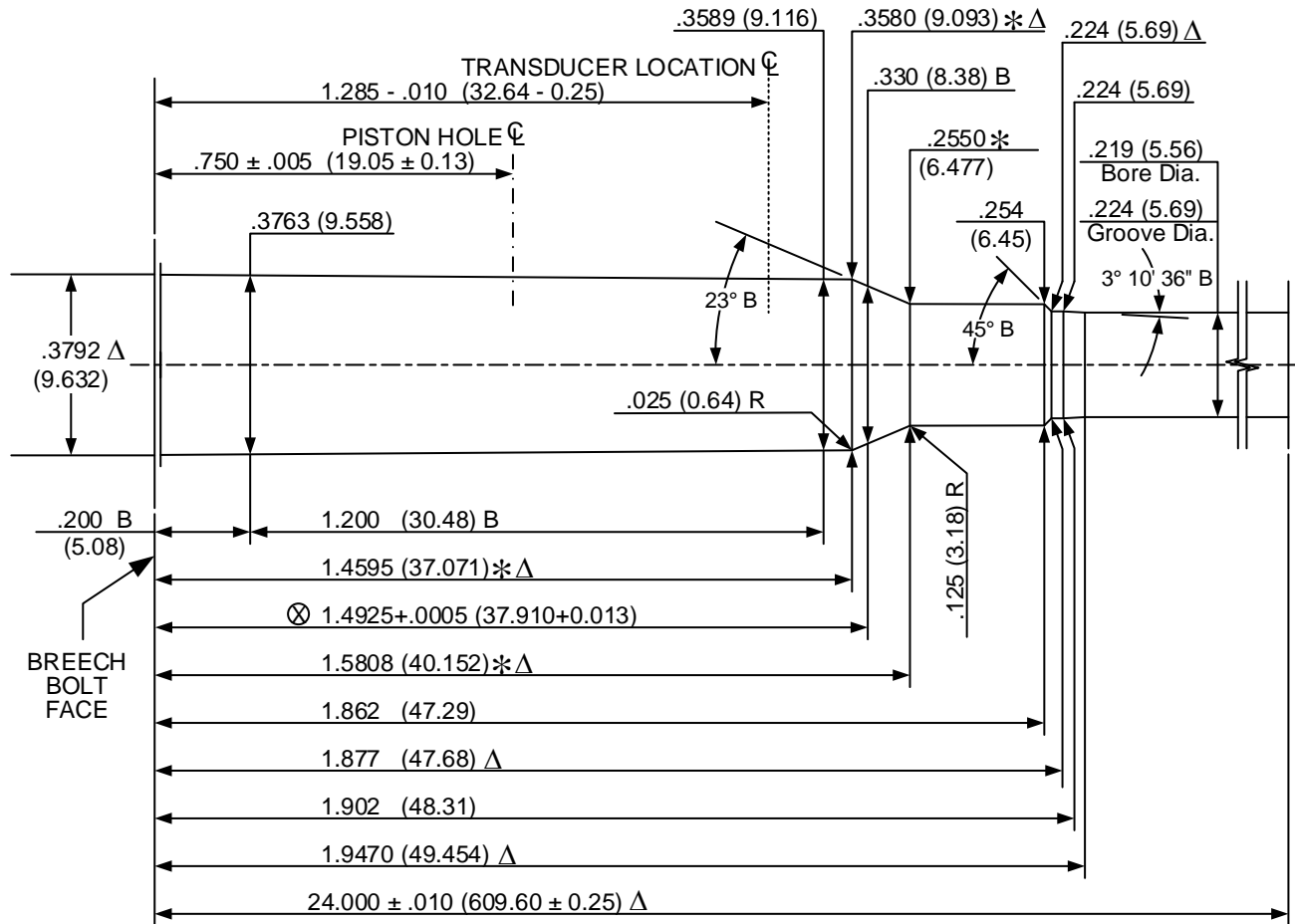

DO NOT SCALE FROM DRAWING

- NUMBER OF GROOVES: 6
- WIDTH OF GROOVES: .080 + .002 (2.03 + 0.05)
- TWIST RATE: 14.00 (355.6) R.H.
- DIAMETER OF PISTON HOLE: .206 (5.23)
- TRANSDUCER DIAMETER: .250 (6.35)

LAND AND GROOVE DIMENSIONS TO BE WITHIN TOLERANCES THROUGHOUT LENGTH OF BARREL.

UNLESS OTHERWISE NOTED, ALL DIAMETERS +.0005 (0.013) LENGTH TOLERANCE + .005 (0.13)

NOTE:

- B = BASIC
- Δ = REFERENCE DIMENSION
- ⊗ = HEADSPACE DIMENSION
- * DIMENSIONS ARE TO INTERSECTIONS OF LINES
- (XX.XX) = MILLIMETERS
- ALL CALCULATIONS APPLY AT MAXIMUM MATERIAL CONDITION (MMC)

223 Remington V&P Test Barrel

Issued: 05/20/1980

Revised: 12/31/2004

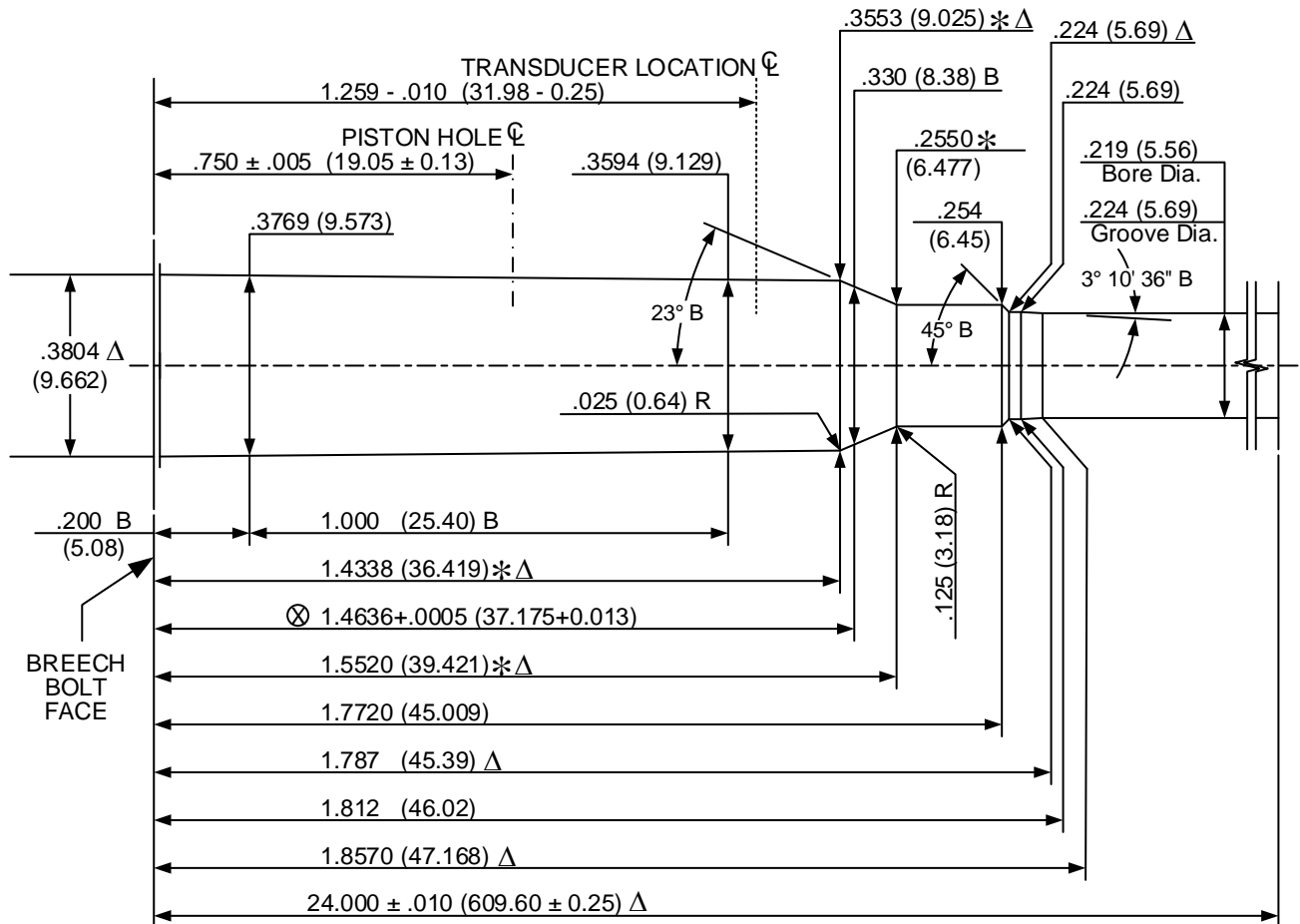

DO NOT SCALE FROM DRAWING

- NUMBER OF GROOVES: 6
- WIDTH OF GROOVES: .074 + .002 (1.88 + 0.05)
- TWIST RATE: 12.00 (304.8) R.H.
- DIAMETER OF PISTON HOLE: .206 (5.23)
- TRANSDUCER DIAMETER: .250 (6.35)

LAND AND GROOVE DIMENSIONS TO BE WITHIN TOLERANCES THROUGHOUT LENGTH OF BARREL.

UNLESS OTHERWISE NOTED, ALL DIAMETERS +.0005 (0.013) LENGTH TOLERANCE + .005 (0.13)

NOTE:

- B = BASIC
- Δ = REFERENCE DIMENSION
- ⊗ = HEADSPACE DIMENSION
- * DIMENSIONS ARE TO INTERSECTIONS OF LINES
- (XX.XX) = MILLIMETERS
- ALL CALCULATIONS APPLY AT MAXIMUM MATERIAL CONDITION (MMC)

223 Winchester Super Short Magnum V&P Test Barrel

Issued: 05/31/2003

Revised: 12/31/2004

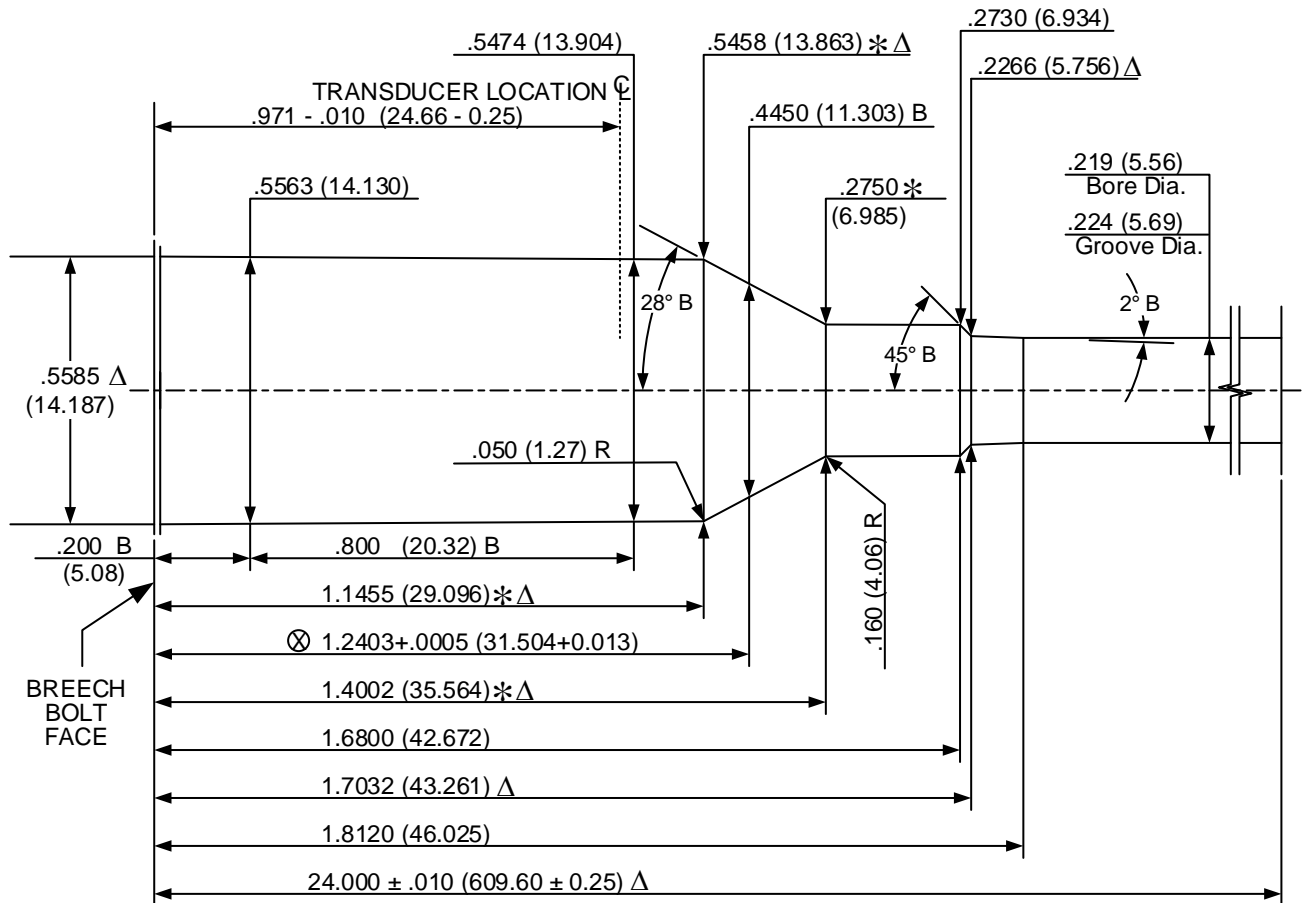

DO NOT SCALE FROM DRAWING

NUMBER OF GROOVES: 6
 WIDTH OF GROOVES: $.080 + .002$ (2.03 + 0.05)
 TWIST RATE: 10.00 (254.0) R.H.
 DIAMETER OF PISTON HOLE: Crusher pressures not established
 TRANSDUCER DIAMETER: $.250$ (6.35)

LAND AND GROOVE DIMENSIONS TO BE WITHIN TOLERANCES THROUGHOUT LENGTH OF BARREL.

UNLESS OTHERWISE NOTED, ALL DIAMETERS $+ .0005$ (0.013) LENGTH TOLERANCE $+ .005$ (0.13)

NOTE:

B = BASIC Δ = REFERENCE DIMENSION \otimes = HEADSPACE DIMENSION
 \ast DIMENSIONS ARE TO INTERSECTIONS OF LINES (XX.XX) = MILLIMETERS
 ALL CALCULATIONS APPLY AT MAXIMUM MATERIAL CONDITION (MMC)

225 Winchester V&P Test Barrel

Issued: 05/20/1980

Revised: 12/31/2004

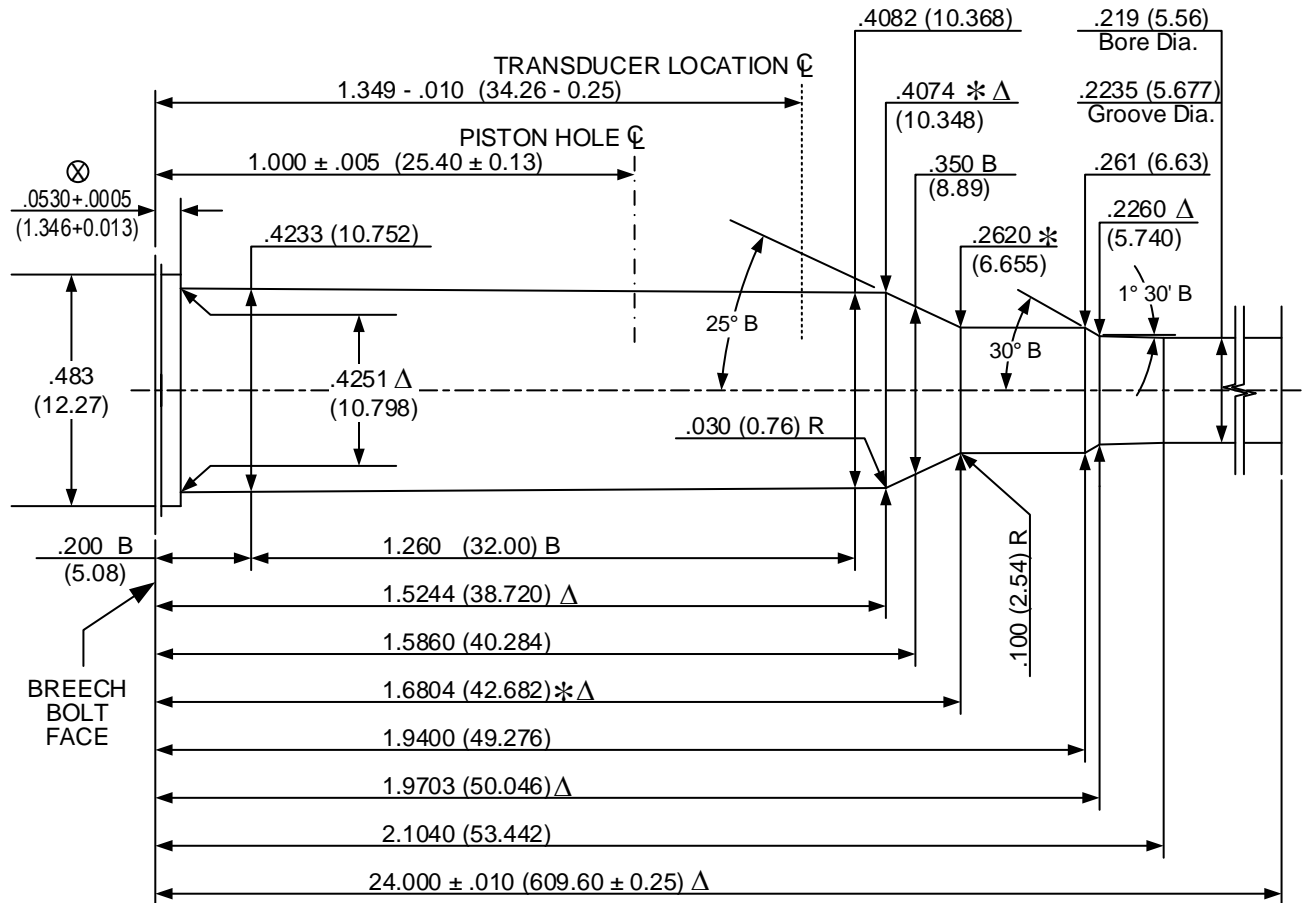

DO NOT SCALE FROM DRAWING

- NUMBER OF GROOVES: 6
- WIDTH OF GROOVES: .074 + .002 (1.88 + 0.05)
- TWIST RATE: 14.00 (355.6) R.H.
- DIAMETER OF PISTON HOLE: .206 (5.23)
- TRANSDUCER DIAMETER: .250 (6.35)

LAND AND GROOVE DIMENSIONS TO BE
 WITHIN TOLERANCES THROUGHOUT
 LENGTH OF BARREL.

UNLESS OTHERWISE NOTED,
 ALL DIAMETERS +.0005 (0.013)
 LENGTH TOLERANCE + .005 (0.13)

NOTE:

- B = BASIC
- Δ = REFERENCE DIMENSION
- ⊗ = HEADSPACE DIMENSION
- * DIMENSIONS ARE TO INTERSECTIONS OF LINES
- (XX.XX) = MILLIMETERS
- ALL CALCULATIONS APPLY AT MAXIMUM MATERIAL CONDITION (MMC)

243 Winchester V&P Test Barrel

Issued: 05/20/1980

Revised: 01/16/2005

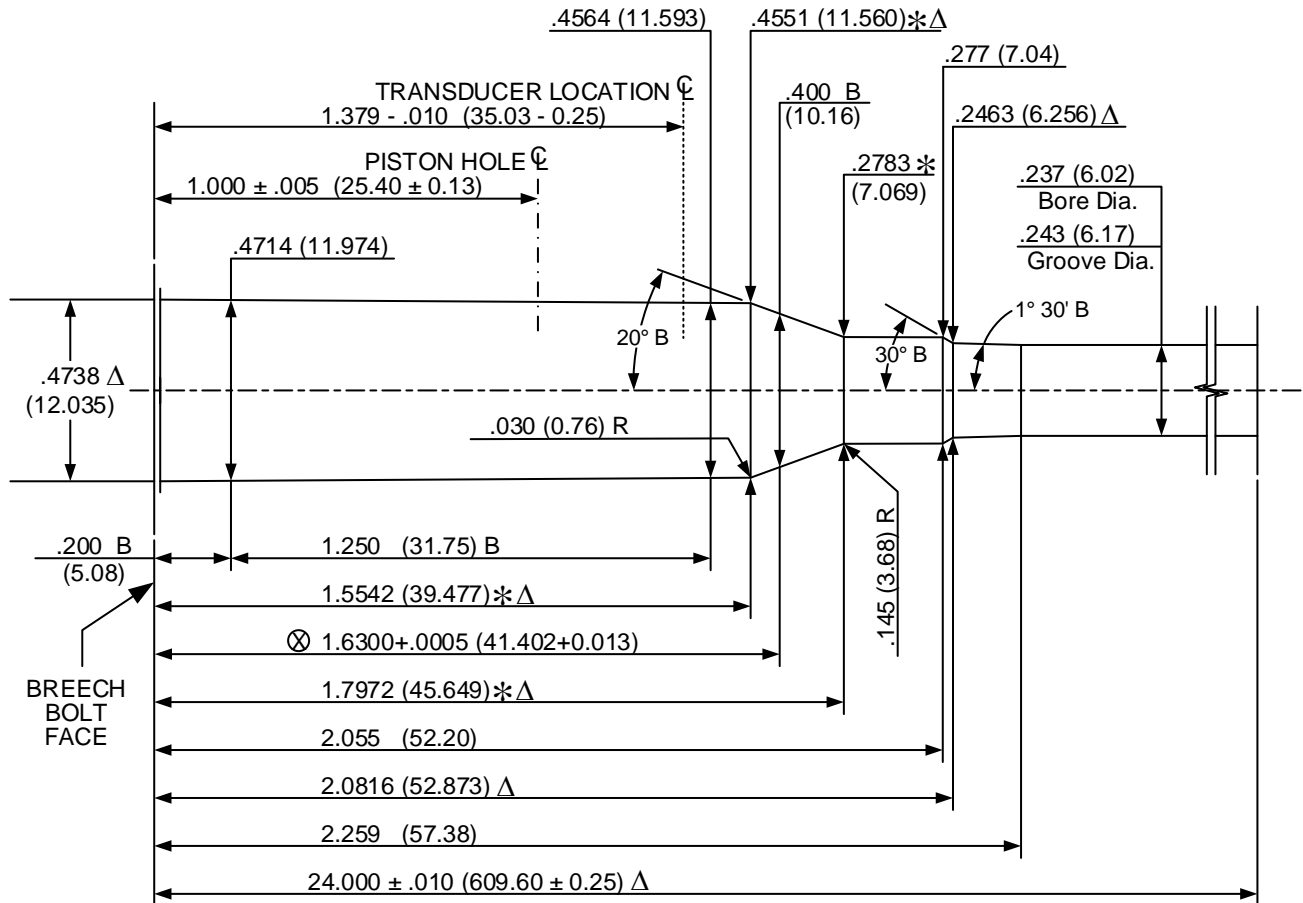

DO NOT SCALE FROM DRAWING

- NUMBER OF GROOVES: 6
- WIDTH OF GROOVES: .068 + .002 (1.73 + 0.05)
- TWIST RATE: 10.00 (254.0) R.H.
- DIAMETER OF PISTON HOLE: .206 (5.23)
- TRANSDUCER DIAMETER: .250 (6.35)

LAND AND GROOVE DIMENSIONS TO BE WITHIN TOLERANCES THROUGHOUT LENGTH OF BARREL.

UNLESS OTHERWISE NOTED, ALL DIAMETERS +.0005 (0.013) LENGTH TOLERANCE + .005 (0.13)

NOTE:

- B = BASIC
- Δ = REFERENCE DIMENSION
- ⊗ = HEADSPACE DIMENSION
- * DIMENSIONS ARE TO INTERSECTIONS OF LINES
- (XX.XX) = MILLIMETERS
- ALL CALCULATIONS APPLY AT MAXIMUM MATERIAL CONDITION (MMC)

243 Winchester Super Short Magnum V&P Test Barrel

Issued: 02/11/2004

Revised: 10/16/2005

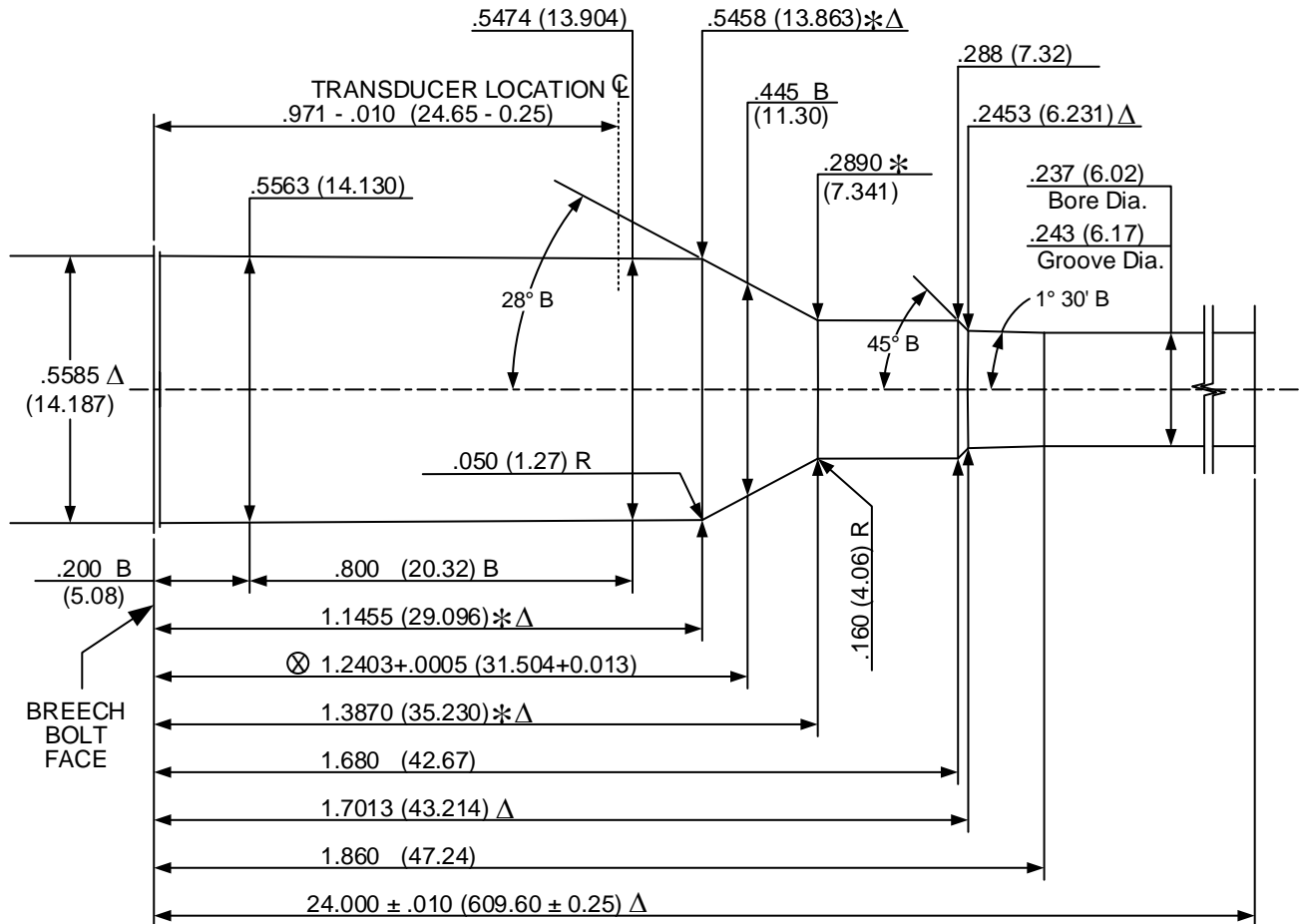

DO SCALE FROM DRAWING

- NUMBER OF GROOVES: 4
- WIDTH OF GROOVES: .100 + .002 (2.54 + 0.05)
- TWIST RATE: 10.00 (254.0) R.H.
- DIAMETER OF PISTON HOLE: Crusher pressures not established
- TRANSDUCER DIAMETER: .250 (6.35)

LAND AND GROOVE DIMENSIONS TO BE WITHIN TOLERANCES THROUGHOUT LENGTH OF BARREL.

UNLESS OTHERWISE NOTED, ALL DIAMETERS +.0005 (0.013) LENGTH TOLERANCE + .005 (0.13)

NOTE:

- B = BASIC
- Δ = REFERENCE DIMENSION
- ⊗ = HEADSPACE DIMENSION
- * DIMENSIONS ARE TO INTERSECTIONS OF LINES
- (XX.XX) = MILLIMETERS
- ALL CALCULATIONS APPLY AT MAXIMUM MATERIAL CONDITION (MMC)

25 Winchester Super Short Magnum V&P Test Barrel

Issued: 06/23/2004

Revised: 10/16/2005

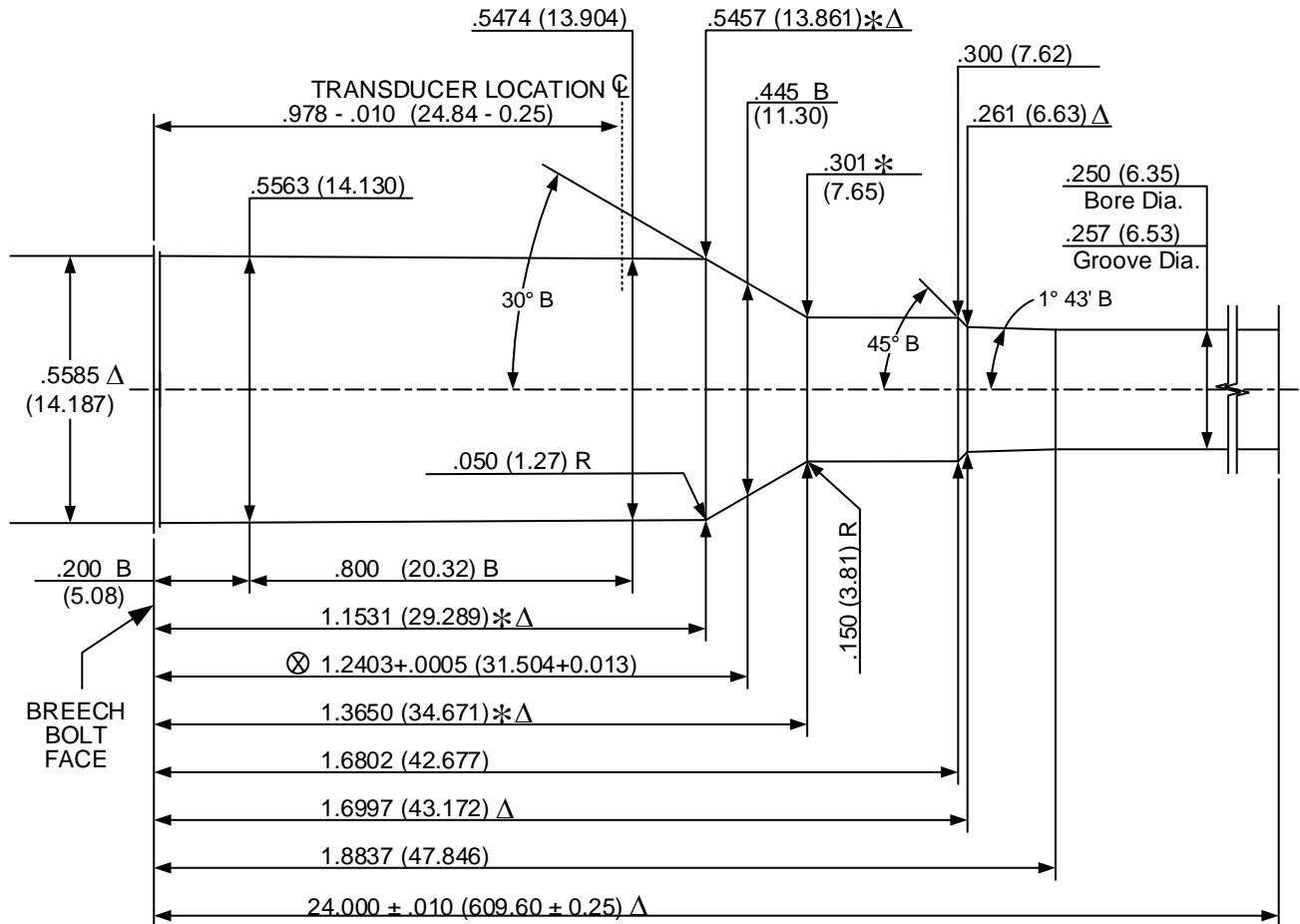

DO NOT SCALE FROM DRAWING

- NUMBER OF GROOVES: 6
- WIDTH OF GROOVES: .096 + .002 (2.44 + 0.05)
- TWIST RATE: 10.00 (254.0) R.H.
- DIAMETER OF PISTON HOLE: Crusher pressures not established
- TRANSDUCER DIAMETER: .250 (6.35)

LAND AND GROOVE DIMENSIONS TO BE WITHIN TOLERANCES THROUGHOUT LENGTH OF BARREL.

UNLESS OTHERWISE NOTED, ALL DIAMETERS +.0005 (0.013) LENGTH TOLERANCE + .005 (0.13)

NOTE:

- B = BASIC
- Δ = REFERENCE DIMENSION
- ⊗ = HEADSPACE DIMENSION
- * DIMENSIONS ARE TO INTERSECTIONS OF LINES
- (XX.XX) = MILLIMETERS
- ALL CALCULATIONS APPLY AT MAXIMUM MATERIAL CONDITION (MMC)

25-06 Remington V&P Test Barrel

Issued: 05/20/1980

Revised: 01/03/2005

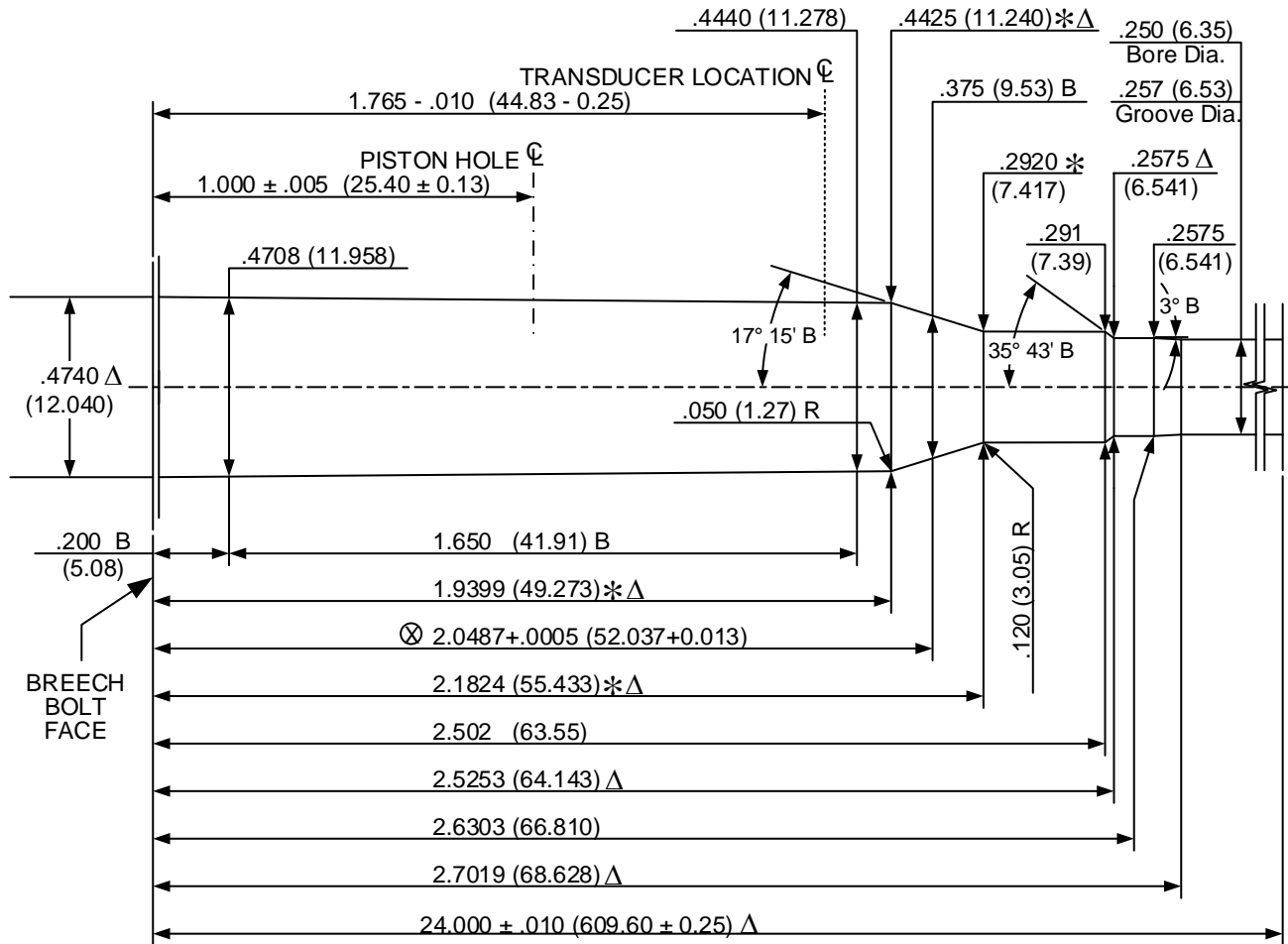

DO NOT SCALE FROM DRAWING

- NUMBER OF GROOVES: 6
- WIDTH OF GROOVES: .096 + .002 (2.44 + 0.05)
- TWIST RATE: 10.00 (254.0) R.H.
- DIAMETER OF PISTON HOLE: .206 (5.23)
- TRANSDUCER DIAMETER: .250 (6.35)

LAND AND GROOVE DIMENSIONS TO BE WITHIN TOLERANCES THROUGHOUT LENGTH OF BARREL.

UNLESS OTHERWISE NOTED, ALL DIAMETERS +.0005 (0.013) LENGTH TOLERANCE + .005 (0.13)

NOTE:

- B = BASIC
- Δ = REFERENCE DIMENSION
- ⊗ = HEADSPACE DIMENSION
- * DIMENSIONS ARE TO INTERSECTIONS OF LINES
- (XX.XX) = MILLIMETERS
- ALL CALCULATIONS APPLY AT MAXIMUM MATERIAL CONDITION (MMC)

25-35 Winchester V&P Test Barrel

Issued: - / - / 2005

Revised: - / - / - - -

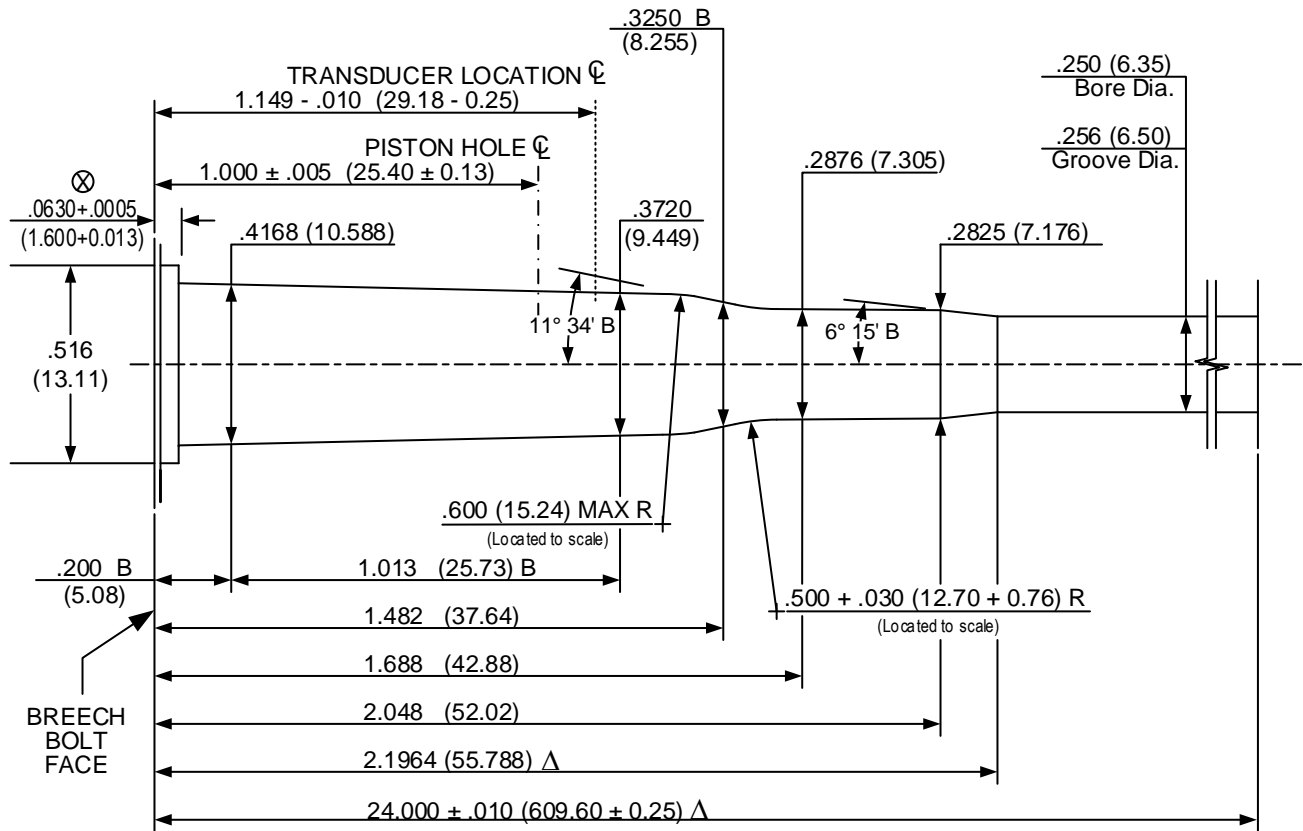

DO NOT SCALE FROM DRAWING

NUMBER OF GROOVES: 6
 WIDTH OF GROOVES: .0786 + .0020 (1.996 + 0.051)
 TWIST RATE: 8.00 (203.2) R.H.
 DIAMETER OF PISTON HOLE: .206 (5.23)
 TRANSDUCER DIAMETER: .250 (6.35)

LAND AND GROOVE DIMENSIONS TO BE WITHIN TOLERANCES THROUGHOUT LENGTH OF BARREL.

UNLESS OTHERWISE NOTED, ALL DIAMETERS +.0005 (0.013) LENGTH TOLERANCE + .005 (0.13)

NOTE:

B = BASIC Δ = REFERENCE DIMENSION ⊗ = HEADSPACE DIMENSION
 * DIMENSIONS ARE TO INTERSECTIONS OF LINES (XX.XX) = MILLIMETERS
 ALL CALCULATIONS APPLY AT MAXIMUM MATERIAL CONDITION (MMC)

250 Savage V&P Test Barrel

Issued: 05/20/1980

Revised: 09/03/2005

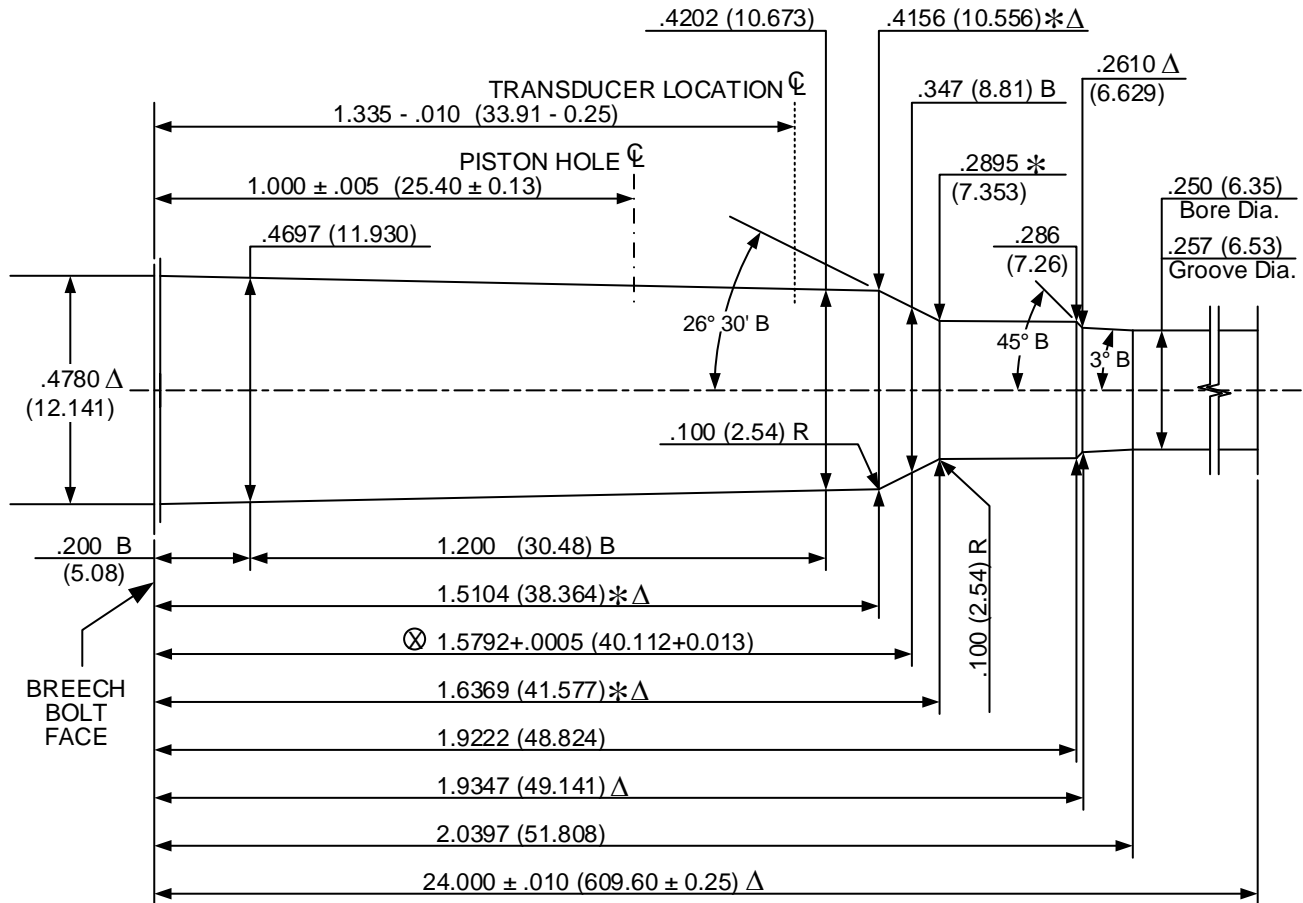

DO NOT SCALE FROM DRAWING

NUMBER OF GROOVES: 6
 WIDTH OF GROOVES: .088 + .002 (2.24 + 0.05)
 TWIST RATE: 14.00 (355.6) R.H.
 DIAMETER OF PISTON HOLE: .206 (5.23)
 TRANSDUCER DIAMETER: .250 (6.35)

LAND AND GROOVE DIMENSIONS TO BE
 WITHIN TOLERANCES THROUGHOUT
 LENGTH OF BARREL.

UNLESS OTHERWISE NOTED,
 ALL DIAMETERS +.0005 (0.013)
 LENGTH TOLERANCE + .005 (0.13)

NOTE:

B = BASIC Δ = REFERENCE DIMENSION ⊗ = HEADSPACE DIMENSION
 * DIMENSIONS ARE TO INTERSECTIONS OF LINES (XX.XX) = MILLIMETERS
 ALL CALCULATIONS APPLY AT MAXIMUM MATERIAL CONDITION (MMC)

257 Roberts / 257 Roberts +P V&P Test Barrel

Issued: 05/20/1980

Revised: 09/03/2005

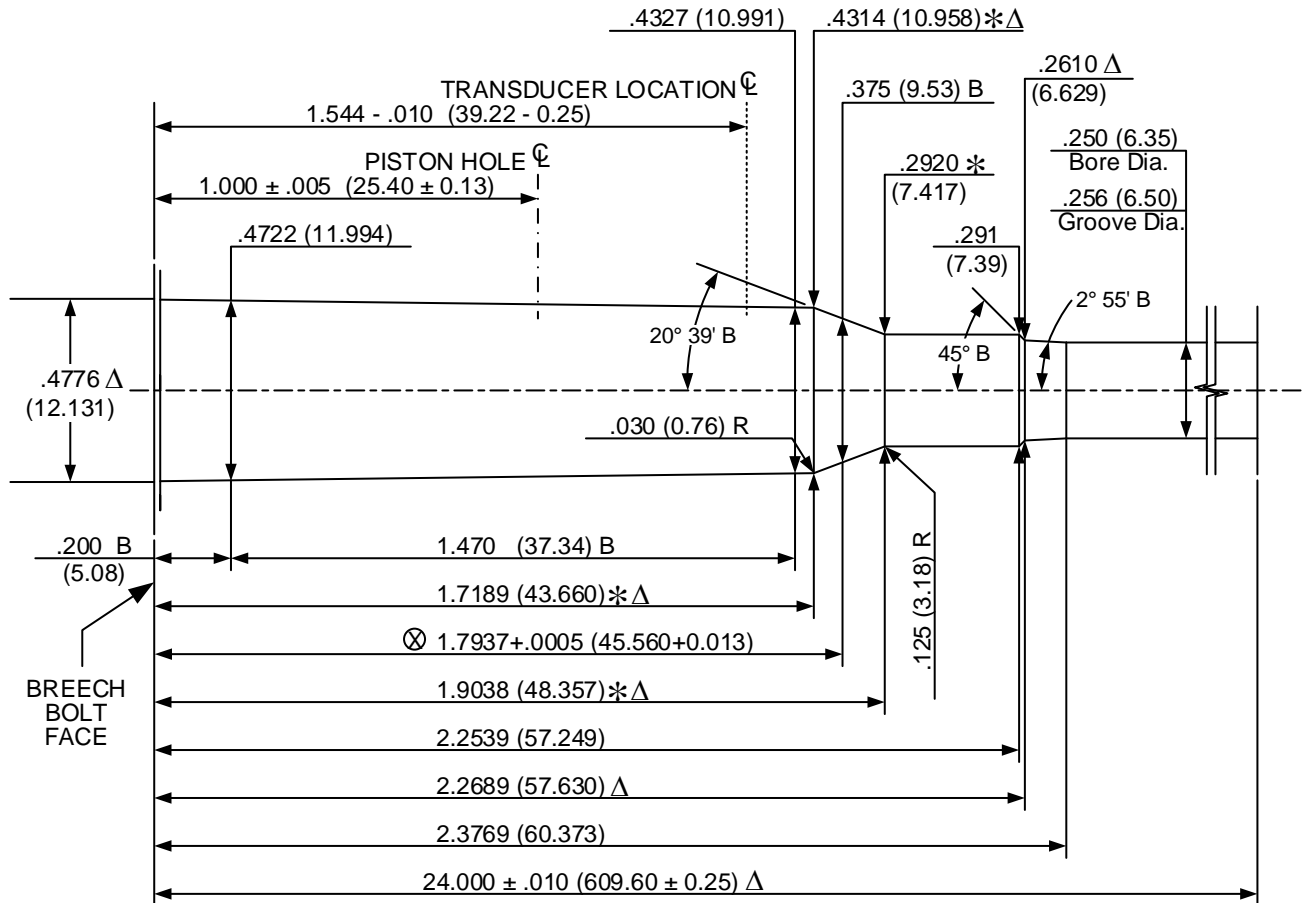

DO NOT SCALE FROM DRAWING

- NUMBER OF GROOVES: 6
- WIDTH OF GROOVES: .095 + .002 (2.41 + 0.05)
- TWIST RATE: 10.00 (254.0) R.H.
- DIAMETER OF PISTON HOLE: .206 (5.23)
- TRANSDUCER DIAMETER: .250 (6.35)

LAND AND GROOVE DIMENSIONS TO BE WITHIN TOLERANCES THROUGHOUT LENGTH OF BARREL.

UNLESS OTHERWISE NOTED, ALL DIAMETERS +.0005 (0.013) LENGTH TOLERANCE + .005 (0.13)

NOTE:

- B = BASIC
- Δ = REFERENCE DIMENSION
- ⊗ = HEADSPACE DIMENSION
- * DIMENSIONS ARE TO INTERSECTIONS OF LINES
- (XX.XX) = MILLIMETERS
- ALL CALCULATIONS APPLY AT MAXIMUM MATERIAL CONDITION (MMC)

257 Weatherby Magnum V&P Test Barrel

Issued: 01/12/1994

Revised: 09/03/2005

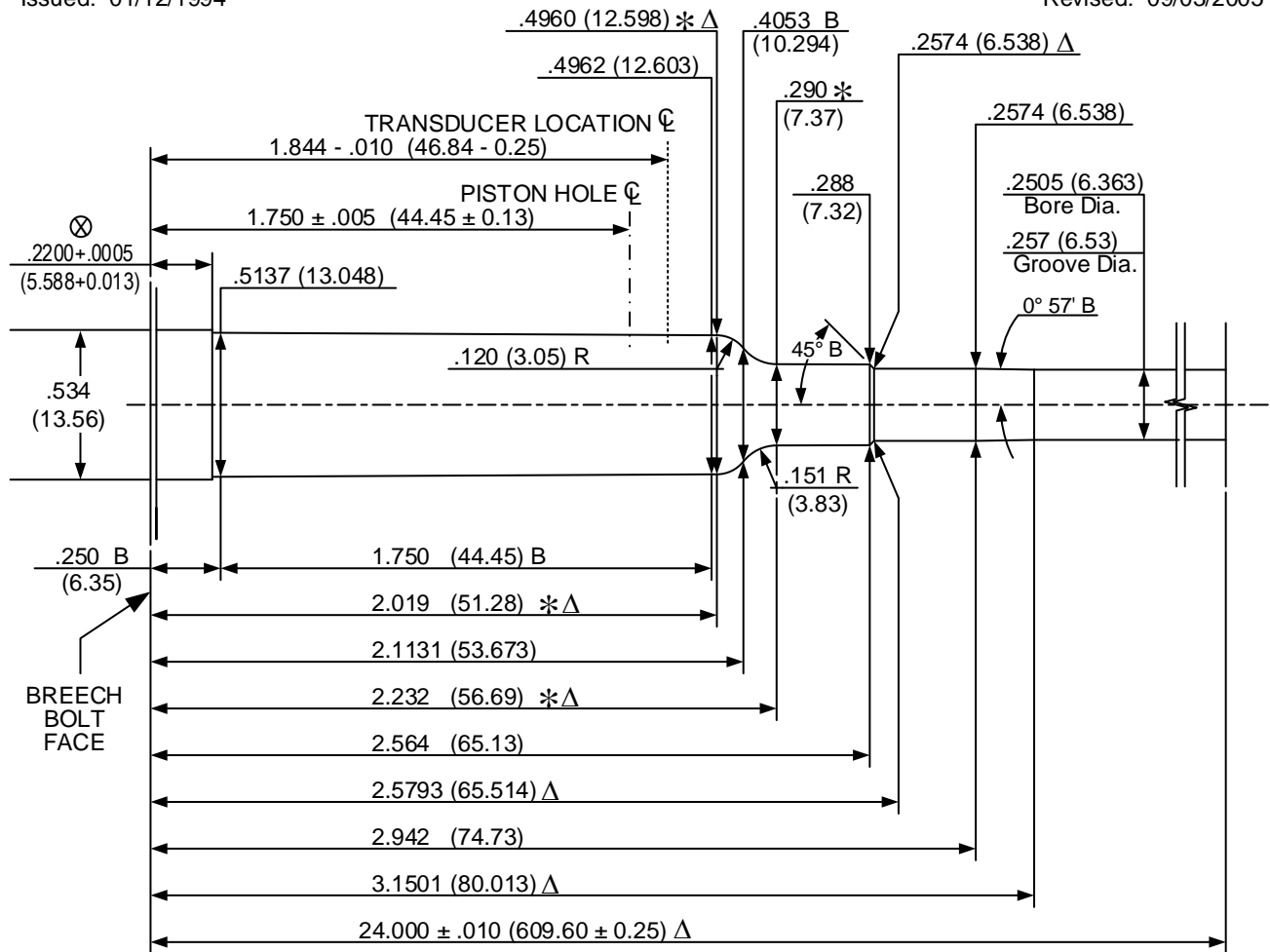

DO NOT SCALE FROM DRAWING

NUMBER OF GROOVES: 6
 WIDTH OF GROOVES: .098 + .002 (2.49 + 0.05)
 TWIST RATE: 10.00 (254.0) R.H.
 DIAMETER OF PISTON HOLE: .206 (5.23)
 TRANSDUCER DIAMETER: .250 (6.35)

LAND AND GROOVE DIMENSIONS TO BE
 WITHIN TOLERANCES THROUGHOUT
 LENGTH OF BARREL.

UNLESS OTHERWISE NOTED,
 ALL DIAMETERS +.0005 (0.013)
 LENGTH TOLERANCE + .005 (0.13)

NOTE:

B = BASIC Δ = REFERENCE DIMENSION ⊗ = HEADSPACE DIMENSION
 * DIMENSIONS ARE TO INTERSECTIONS OF LINES (XX.XX) = MILLIMETERS
 ALL CALCULATIONS APPLY AT MAXIMUM MATERIAL CONDITION (MMC)

26 Nosler V&P Test Barrel

Issued: 01/01/2014

Revised: 01/01/2014

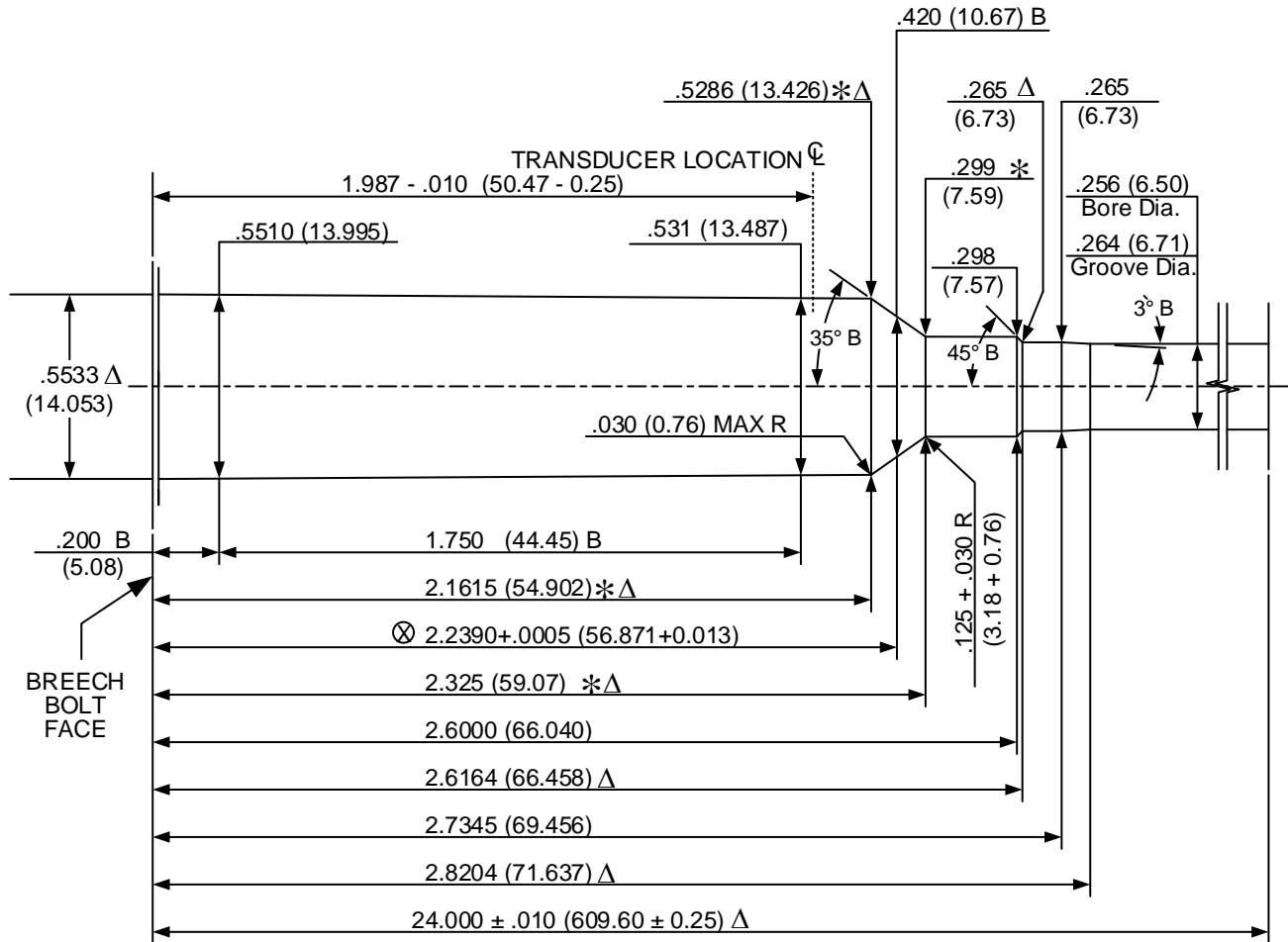

DO NOT SCALE FROM DRAWING

- NUMBER OF GROOVES: 6
- WIDTH OF GROOVES: .095 + .002 (2.41 + 0.05)
- TWIST RATE: 8.00 (203.2) R.H.
- DIAMETER OF PISTON HOLE: Crusher pressures not established
- TRANSDUCER DIAMETER: .250 (6.35)

LAND AND GROOVE DIMENSIONS TO BE
 WITHIN TOLERANCES THROUGHOUT
 LENGTH OF BARREL.

UNLESS OTHERWISE NOTED,
 ALL DIAMETERS +.0005 (0.013)
 LENGTH TOLERANCE + .005 (0.13)

NOTE:

- B = BASIC
- Δ = REFERENCE DIMENSION
- ⊗ = HEADSPACE DIMENSION
- * DIMENSIONS ARE TO INTERSECTIONS OF LINES
- (XX.XX) = MILLIMETERS
- ALL CALCULATIONS APPLY AT MAXIMUM MATERIAL CONDITION (MMC)

260 Remington V&P Test Barrel

Issued: 01/29/1997

Revised: 09/03/2005

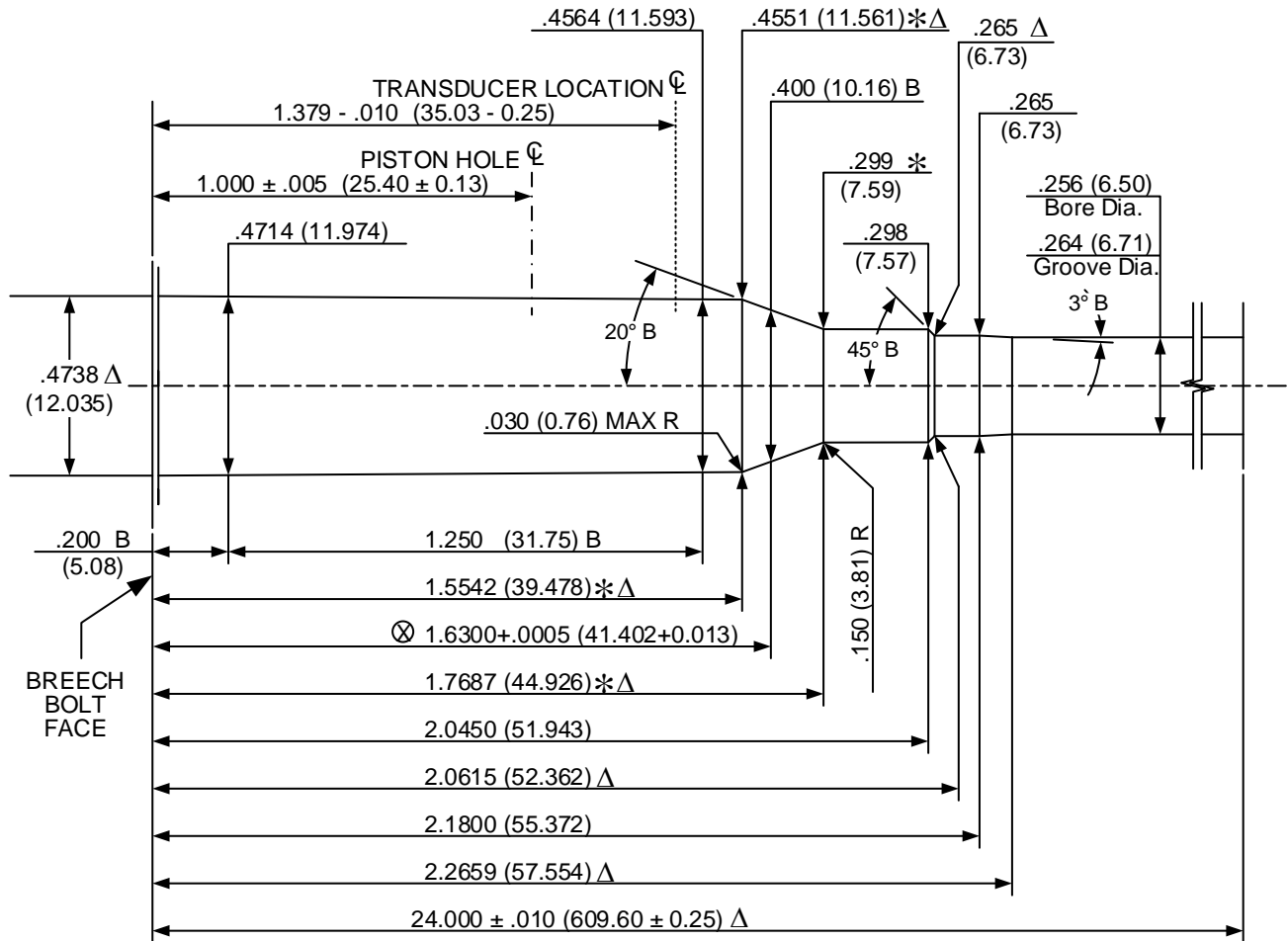

DO NOT SCALE FROM DRAWING

- NUMBER OF GROOVES: 6
- WIDTH OF GROOVES: .095 + .002 (2.41 + 0.05)
- TWIST RATE: 9.00 (228.6) R.H.
- DIAMETER OF PISTON HOLE: .206 (5.23)
- TRANSDUCER DIAMETER: .250 (6.35)

LAND AND GROOVE DIMENSIONS TO BE WITHIN TOLERANCES THROUGHOUT LENGTH OF BARREL.

UNLESS OTHERWISE NOTED, ALL DIAMETERS +.0005 (0.013) LENGTH TOLERANCE + .005 (0.13)

NOTE:

- B = BASIC
- Δ = REFERENCE DIMENSION
- ⊗ = HEADSPACE DIMENSION
- * DIMENSIONS ARE TO INTERSECTIONS OF LINES
- (XX.XX) = MILLIMETERS
- ALL CALCULATIONS APPLY AT MAXIMUM MATERIAL CONDITION (MMC)

27 Nosler V&P Test Barrel

Issued: 01/19/2015

Revised: - - / - - / - - - -

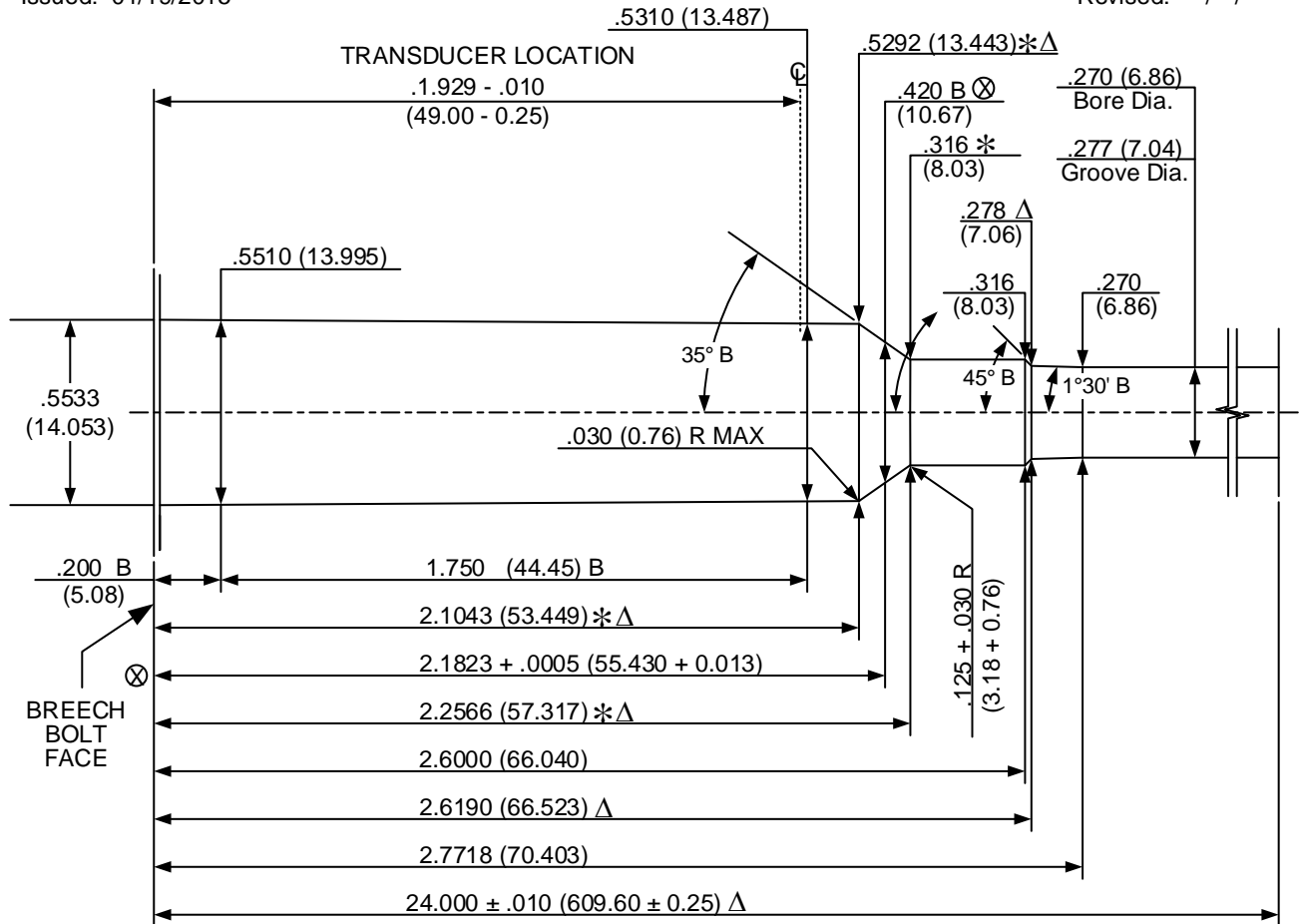

DO NOT SCALE FROM DRAWING

NUMBER OF GROOVES: 4
 WIDTH OF GROOVES: .160 + .002 (4.06 + 0.05)
 TWIST RATE: 10.00 (254.0) R.H.
 DIAMETER OF PISTON HOLE: Crusher pressures not established.
 TRANSDUCER DIAMETER: .250 (6.35)

LAND AND GROOVE DIMENSIONS TO BE
 WITHIN TOLERANCES THROUGHOUT
 LENGTH OF BARREL.

UNLESS OTHERWISE NOTED,
 ALL DIAMETERS +.0005 (0.013)
 LENGTH TOLERANCE + .005 (0.13)

NOTE:

B = BASIC Δ = REFERENCE DIMENSION ⊗ = HEADSPACE DIMENSION
 * DIMENSIONS ARE TO INTERSECTIONS OF LINES (XX.XX) = MILLIMETERS
 ALL CALCULATIONS APPLY AT MAXIMUM MATERIAL CONDITION (MMC)

270 Weatherby Magnum V&P Test Barrel

Issued: 09/16/1996

Revised: 09/03/2005

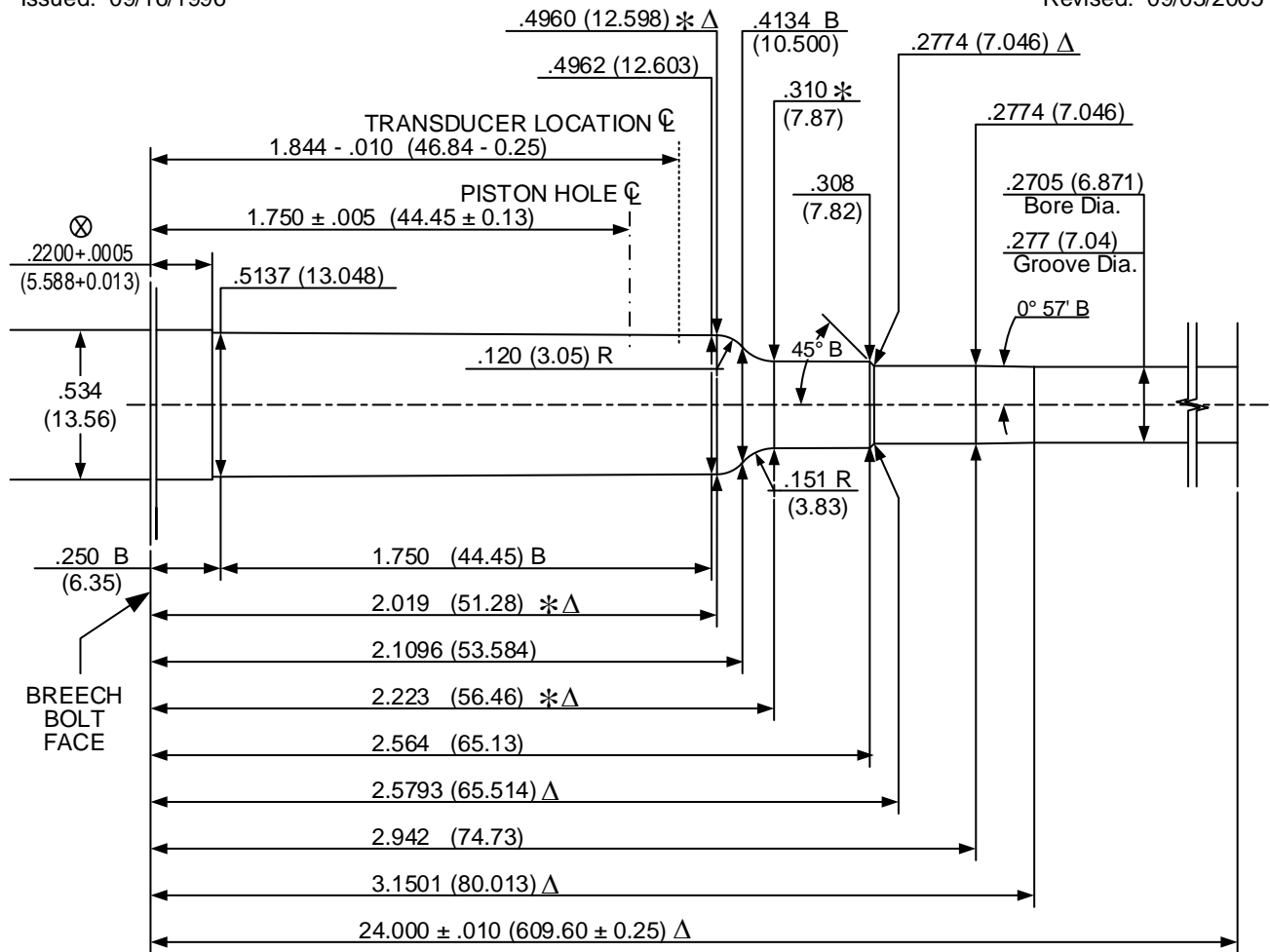

DO NOT SCALE FROM DRAWING

- NUMBER OF GROOVES: 6
- WIDTH OF GROOVES: .108 + .002 (2.74 + 0.05)
- TWIST RATE: 10.00 (254.0) R.H.
- DIAMETER OF PISTON HOLE: .206 (5.23)
- TRANSDUCER DIAMETER: .250 (6.35)

LAND AND GROOVE DIMENSIONS TO BE WITHIN TOLERANCES THROUGHOUT LENGTH OF BARREL.

UNLESS OTHERWISE NOTED, ALL DIAMETERS +.0005 (0.013) LENGTH TOLERANCE + .005 (0.13)

NOTE:

- B = BASIC
- Δ = REFERENCE DIMENSION
- ⊗ = HEADSPACE DIMENSION
- * DIMENSIONS ARE TO INTERSECTIONS OF LINES
- (XX.XX) = MILLIMETERS
- ALL CALCULATIONS APPLY AT MAXIMUM MATERIAL CONDITION (MMC)

270 Winchester V&P Test Barrel

Issued: 05/20/1980

Revised: 09/03/2005

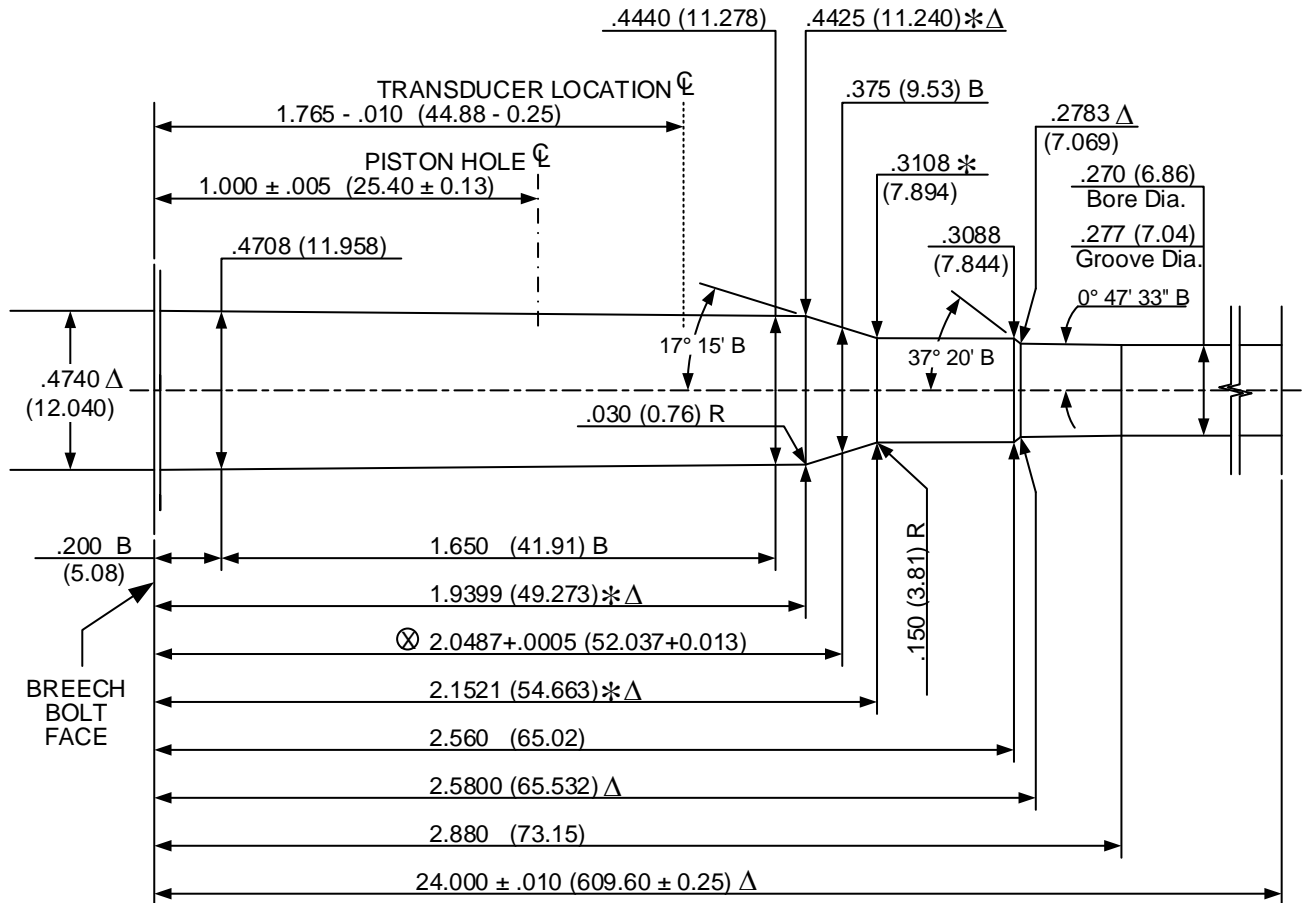

DO NOT SCALE FROM DRAWING

- NUMBER OF GROOVES: 4
- WIDTH OF GROOVES: .160 + .002 (4.06 + 0.05)
- TWIST RATE: 10.00 (254.0) R.H.
- DIAMETER OF PISTON HOLE: .206 (5.23)
- TRANSDUCER DIAMETER: .250 (6.35)

LAND AND GROOVE DIMENSIONS TO BE WITHIN TOLERANCES THROUGHOUT LENGTH OF BARREL.

UNLESS OTHERWISE NOTED, ALL DIAMETERS +.0005 (0.013) LENGTH TOLERANCE + .005 (0.13)

NOTE:

- B = BASIC Δ = REFERENCE DIMENSION ⊗ = HEADSPACE DIMENSION
- * DIMENSIONS ARE TO INTERSECTIONS OF LINES (XX.XX) = MILLIMETERS
- ALL CALCULATIONS APPLY AT MAXIMUM MATERIAL CONDITION (MMC)

270 Winchester Short Magnum V&P Test Barrel

Issued: 02/01/2002

Revised: 10/16/2005

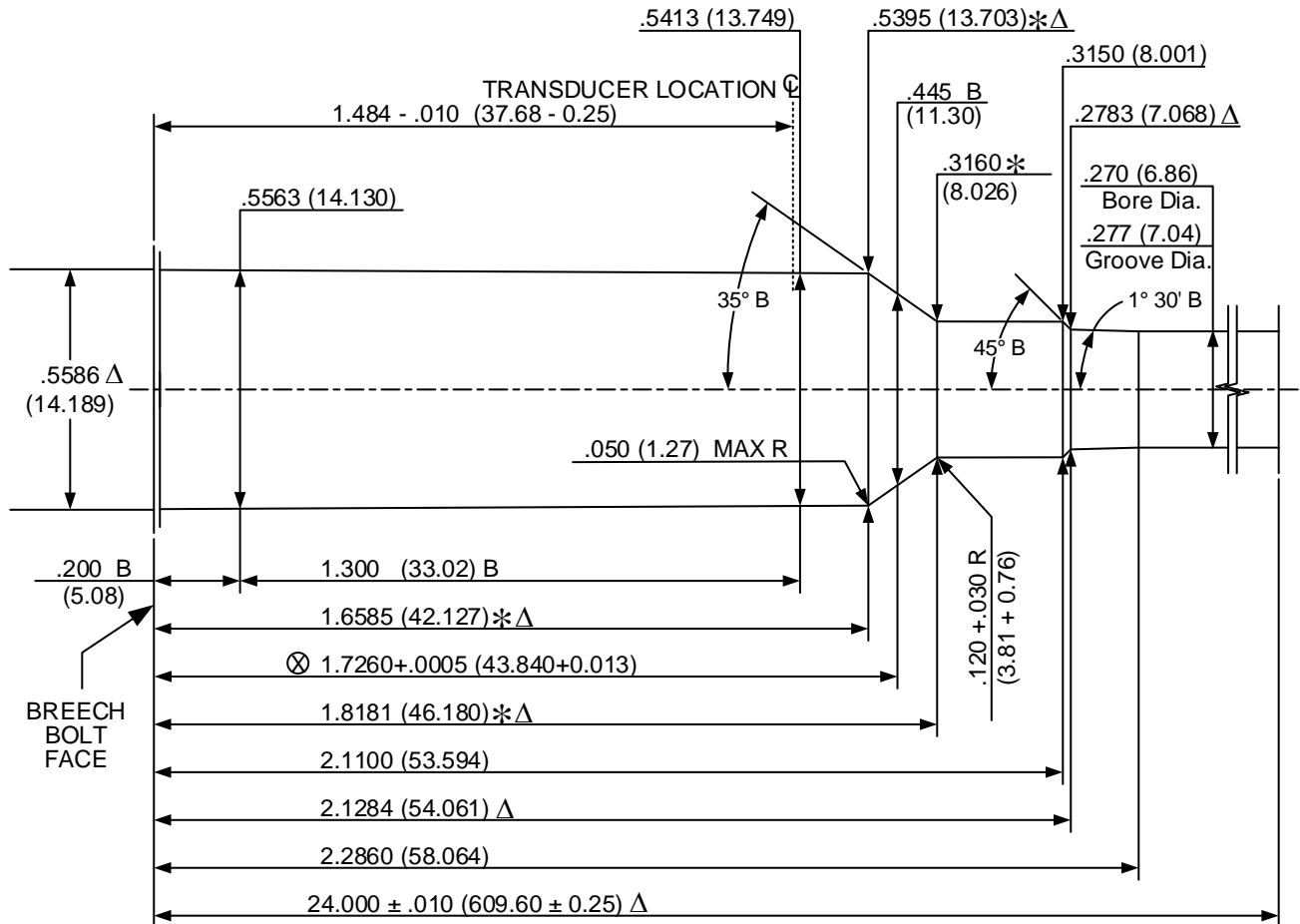

DO NOT SCALE FROM DRAWING

- NUMBER OF GROOVES: 4
- WIDTH OF GROOVES: .160 + .002 (4.06 + 0.05)
- TWIST RATE: 10.00 (254.0) R.H.
- DIAMETER OF PISTON HOLE: Crusher pressures not established
- TRANSDUCER DIAMETER: .250 (6.35)

LAND AND GROOVE DIMENSIONS TO BE WITHIN TOLERANCES THROUGHOUT LENGTH OF BARREL.

UNLESS OTHERWISE NOTED, ALL DIAMETERS +.0005 (0.013) LENGTH TOLERANCE + .005 (0.13)

NOTE:

- B = BASIC
- Δ = REFERENCE DIMENSION
- ⊗ = HEADSPACE DIMENSION
- * DIMENSIONS ARE TO INTERSECTIONS OF LINES
- (XX.XX) = MILLIMETERS
- ALL CALCULATIONS APPLY AT MAXIMUM MATERIAL CONDITION (MMC)

28 Nosler V&P Test Barrel

Issued: 01/19/2015

Revised: - - / - - / - - - -

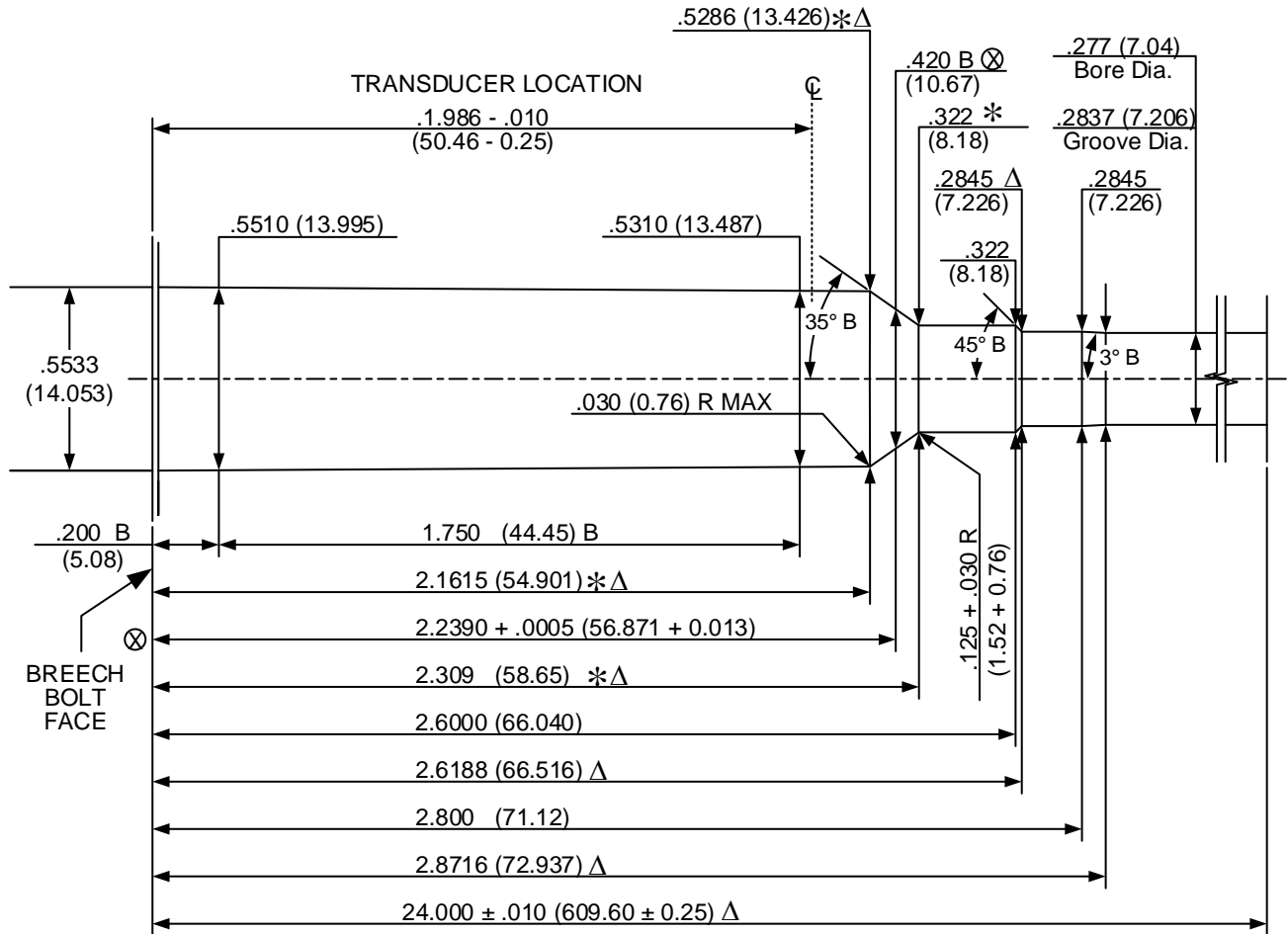

DO NOT SCALE FROM DRAWING

- NUMBER OF GROOVES: 6
- WIDTH OF GROOVES: .110 + .002 (2.79 + 0.05)
- TWIST RATE: 9.00 (228.6) R.H.
- DIAMETER OF PISTON HOLE: Crusher pressures not established.
- TRANSDUCER DIAMETER: .250 (6.35)

LAND AND GROOVE DIMENSIONS TO BE
 WITHIN TOLERANCES THROUGHOUT
 LENGTH OF BARREL.

UNLESS OTHERWISE NOTED,
 ALL DIAMETERS +.0005 (0.013)
 LENGTH TOLERANCE + .005 (0.13)

NOTE:

- B = BASIC
- Δ = REFERENCE DIMENSION
- ⊗ = HEADSPACE DIMENSION
- * DIMENSIONS ARE TO INTERSECTIONS OF LINES
- (XX.XX) = MILLIMETERS
- ALL CALCULATIONS APPLY AT MAXIMUM MATERIAL CONDITION (MMC)

280 Ackley Improved

Issued: 01/31/2008

Revised:

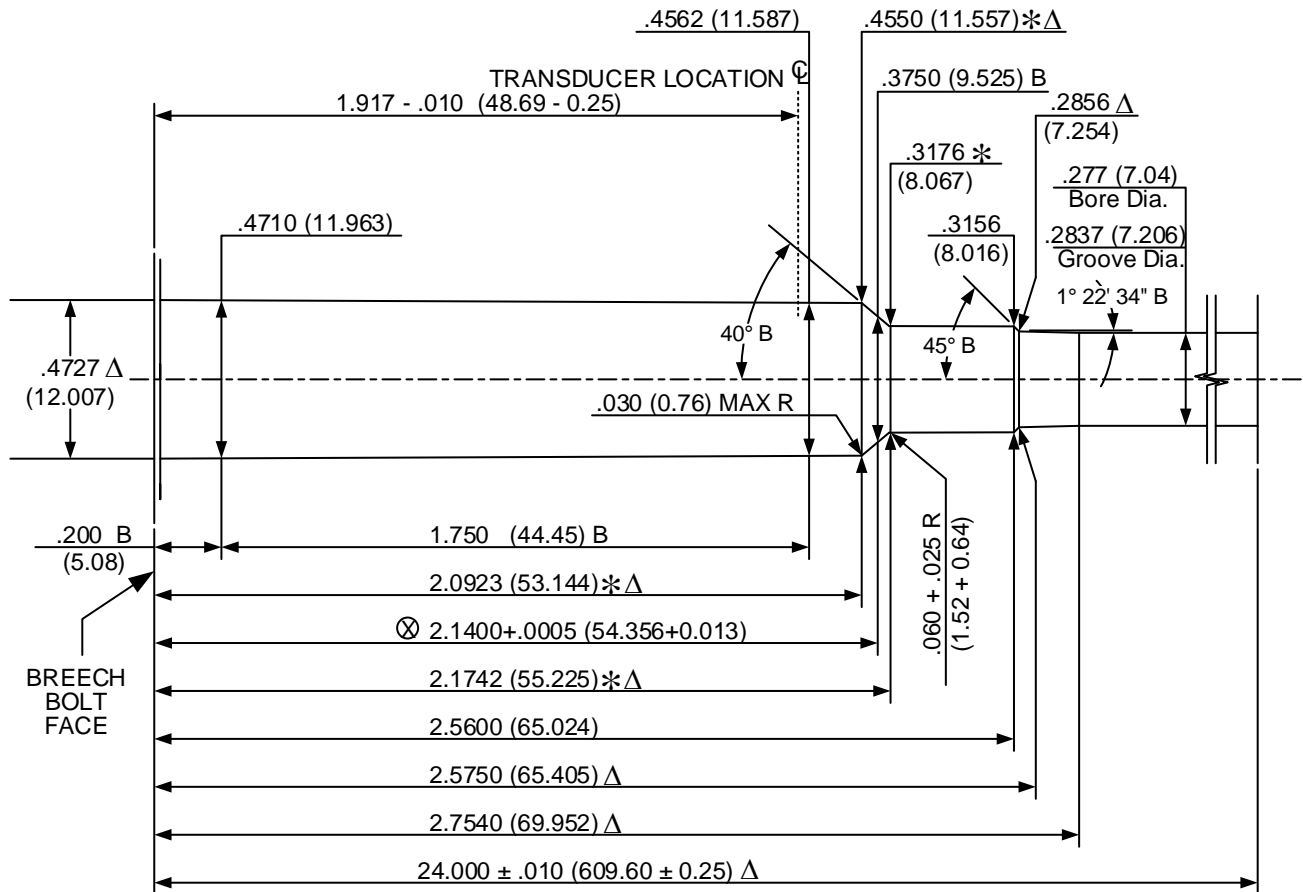

DO NOT SCALE FROM DRAWING

NUMBER OF GROOVES: 4
 WIDTH OF GROOVES: .160 + .002 (4.06 + 0.05)
 TWIST RATE: 9.00 (228.6) R.H.
 DIAMETER OF PISTON HOLE: Crusher pressures not established
 TRANSDUCER DIAMETER: .250 (6.35)

LAND AND GROOVE DIMENSIONS TO BE
 WITHIN TOLERANCES THROUGHOUT
 LENGTH OF BARREL.

UNLESS OTHERWISE NOTED,
 ALL DIAMETERS +.0005 (0.013)
 LENGTH TOLERANCE + .005 (0.13)

NOTE:

B = BASIC Δ = REFERENCE DIMENSION ⊗ = HEADSPACE DIMENSION
 * DIMENSIONS ARE TO INTERSECTIONS OF LINES (XX.XX) = MILLIMETERS
 ALL CALCULATIONS APPLY AT MAXIMUM MATERIAL CONDITION (MMC)

284 Winchester V&P Test Barrel

Issued: 05/20/1980

Revised: 09/04/2005

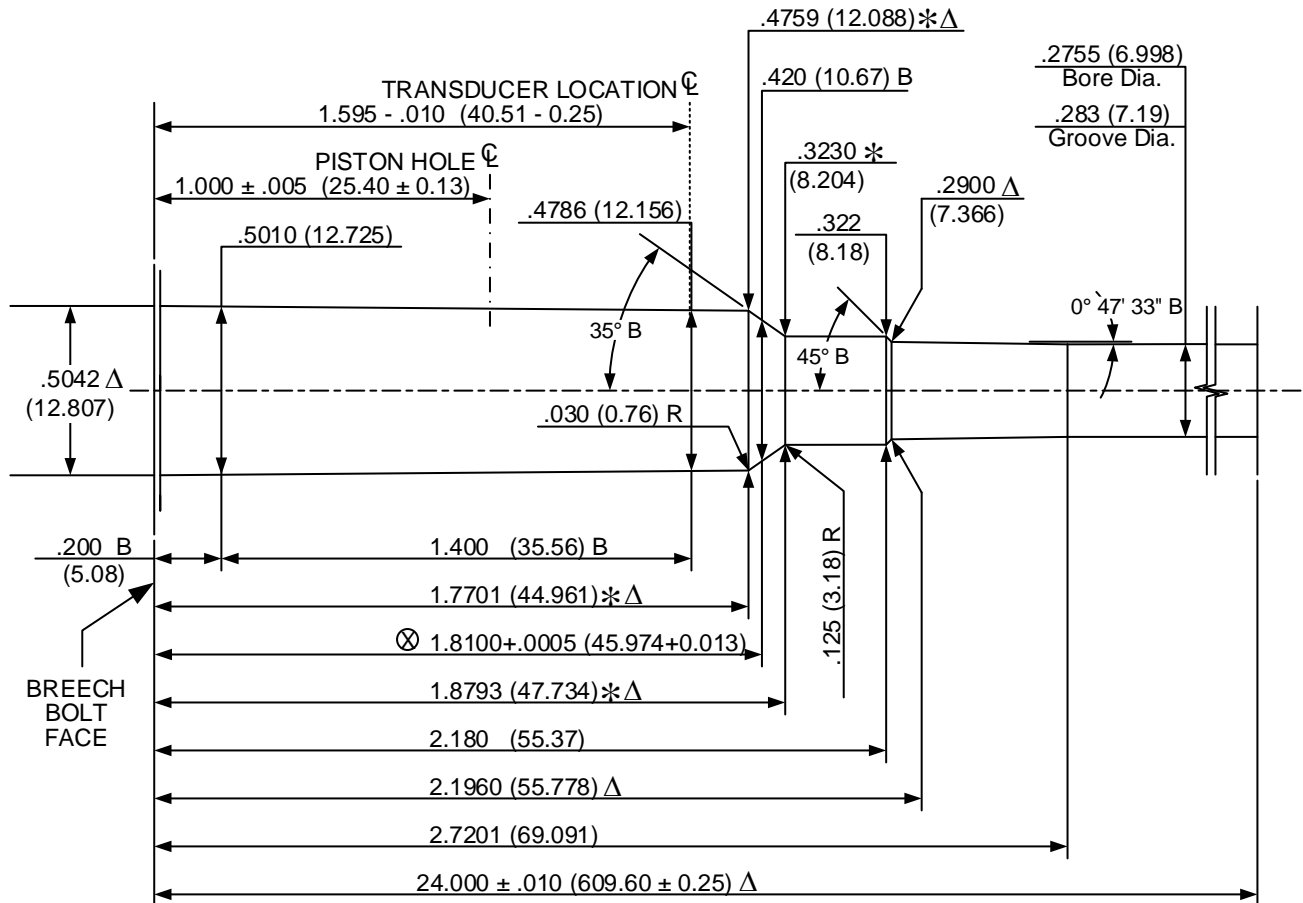

DO NOT SCALE FROM DRAWING

NUMBER OF GROOVES: 6
 WIDTH OF GROOVES: .110 + .002 (2.79 + 0.05)
 TWIST RATE: 10.00 (254.0) R.H.
 DIAMETER OF PISTON HOLE: .206 (5.23)
 TRANSDUCER DIAMETER: .250 (6.35)

LAND AND GROOVE DIMENSIONS TO BE
 WITHIN TOLERANCES THROUGHOUT
 LENGTH OF BARREL.

UNLESS OTHERWISE NOTED,
 ALL DIAMETERS +.0005 (0.013)
 LENGTH TOLERANCE + .005 (0.13)

NOTE:

B = BASIC Δ = REFERENCE DIMENSION ⊗ = HEADSPACE DIMENSION
 * DIMENSIONS ARE TO INTERSECTIONS OF LINES (XX.XX) = MILLIMETERS
 ALL CALCULATIONS APPLY AT MAXIMUM MATERIAL CONDITION (MMC)

30 Carbine V&P Test Barrel

Issued: 05/20/1980

Revised: 04/19/2009

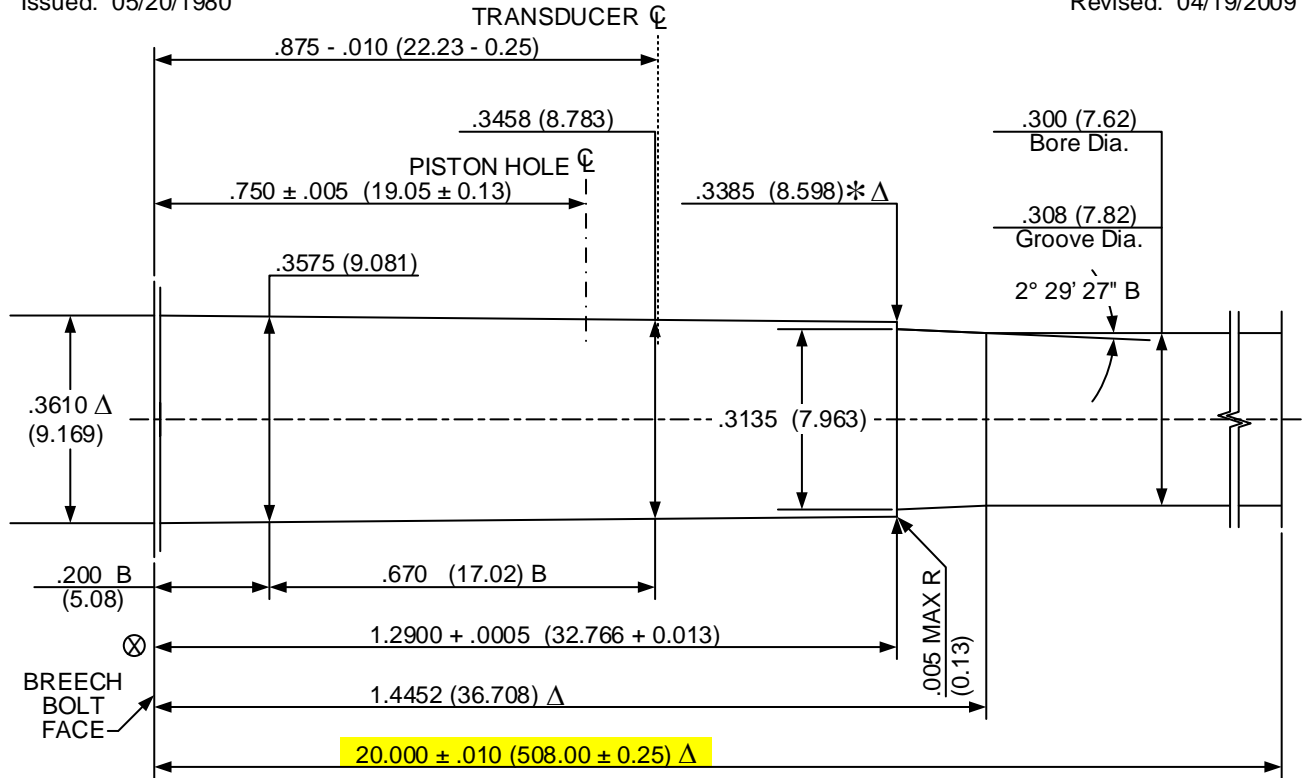

DO NOT SCALE FROM DRAWING

- NUMBER OF GROOVES: 4
- WIDTH OF GROOVES: .167 + .002 (4.24 + 0.05)
- TWIST RATE: 20.00 (508.0) R.H.
- DIAMETER OF PISTON HOLE: .206 (5.23)
- TRANSDUCER DIAMETER: .194 (4.93)**

LAND AND GROOVE DIMENSIONS TO BE WITHIN TOLERANCES THROUGHOUT LENGTH OF BARREL.

UNLESS OTHERWISE NOTED, ALL DIAMETERS +.0005 (0.013) LENGTH TOLERANCE + .005 (0.13)

NOTE:

- B = BASIC Δ = REFERENCE DIMENSION ⊗ = HEADSPACE DIMENSION
- * DIMENSIONS ARE TO INTERSECTIONS OF LINES (XX.XX) = MILLIMETERS
- ALL CALCULATIONS APPLY AT MAXIMUM MATERIAL CONDITION (MMC)

30 Nosler V&P Test Barrel

Issued: 01/19/2015

Revised: - - / - - / - - - -

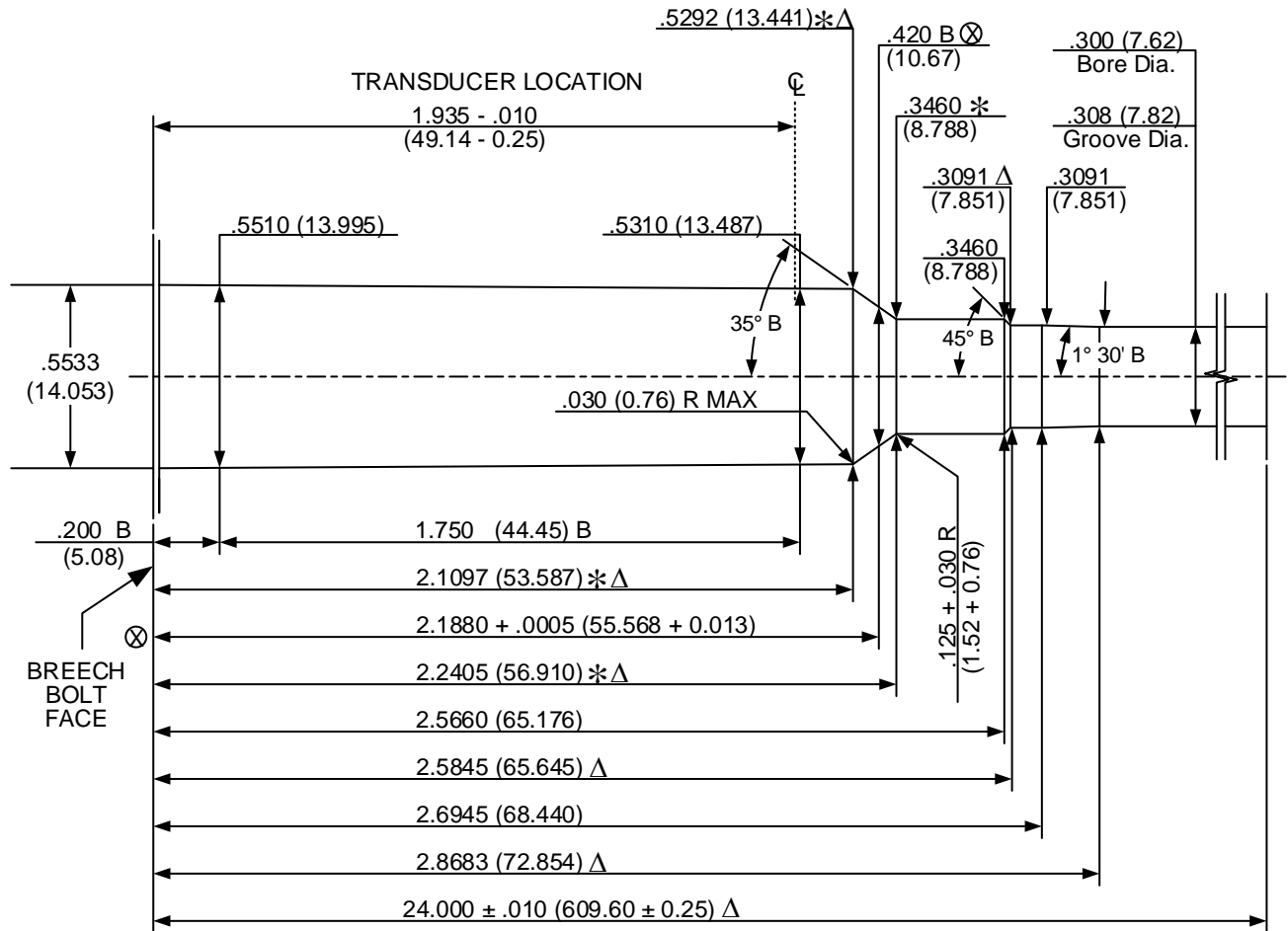

DO NOT SCALE FROM DRAWING

- NUMBER OF GROOVES: 6
- WIDTH OF GROOVES: .110 + .002 (2.79 + 0.05)
- TWIST RATE: 10.00 (254.0) R.H.
- DIAMETER OF PISTON HOLE: Crusher pressures not established.
- TRANSDUCER DIAMETER: .250 (6.35)

LAND AND GROOVE DIMENSIONS TO BE
 WITHIN TOLERANCES THROUGHOUT
 LENGTH OF BARREL.

UNLESS OTHERWISE NOTED,
 ALL DIAMETERS +.0005 (0.013)
 LENGTH TOLERANCE + .005 (0.13)

NOTE:

B = BASIC Δ = REFERENCE DIMENSION ⊗ = HEADSPACE DIMENSION
 * DIMENSIONS ARE TO INTERSECTIONS OF LINES (XX.XX) = MILLIMETERS
 ALL CALCULATIONS APPLY AT MAXIMUM MATERIAL CONDITION (MMC)

30 Remington AR V&P Test Barrel

Issued: 06/17/2009

Revised: - - / - - / - - - -

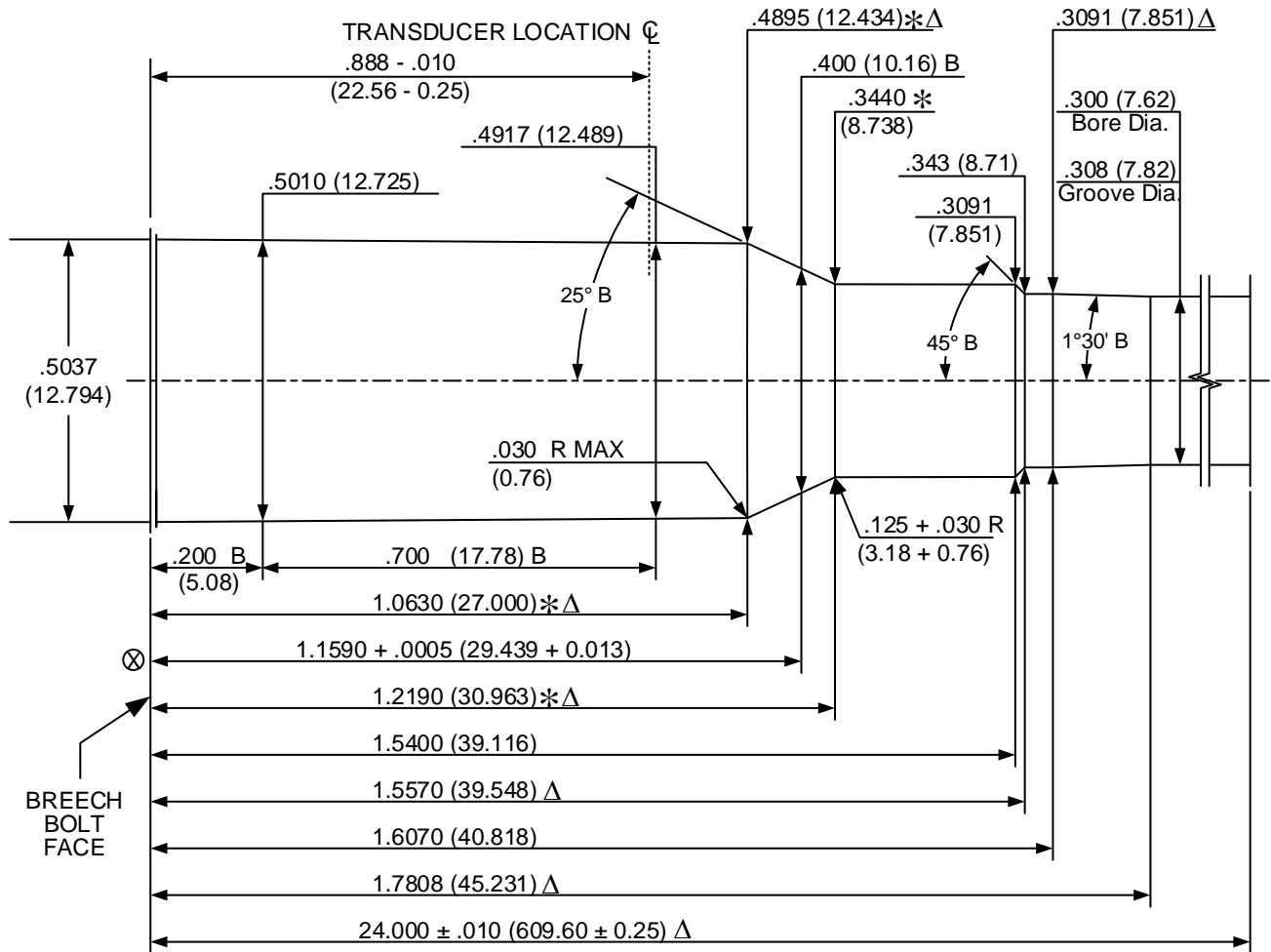

DO NOT SCALE FROM DRAWING

- NUMBER OF GROOVES: 4
- WIDTH OF GROOVES: .176 + .002 (4.47 + 0.05)
- TWIST RATE: 10.00 (254.0) R.H.
- DIAMETER OF PISTON HOLE: Crusher pressures not established.
- TRANSDUCER DIAMETER: .250 (6.35)

LAND AND GROOVE DIMENSIONS TO BE WITHIN TOLERANCES THROUGHOUT LENGTH OF BARREL.

UNLESS OTHERWISE NOTED, ALL DIAMETERS +.0005 (0.013) LENGTH TOLERANCE + .005 (0.13)

NOTE:

B = BASIC Δ = REFERENCE DIMENSION ⊗ = HEADSPACE DIMENSION
 * DIMENSIONS ARE TO INTERSECTIONS OF LINES (XX.XX) = MILLIMETERS
 ALL CALCULATIONS APPLY AT MAXIMUM MATERIAL CONDITION (MMC)

30 Thompson Center V&P Test Barrel

Issued: 01/31/2008

Revised:

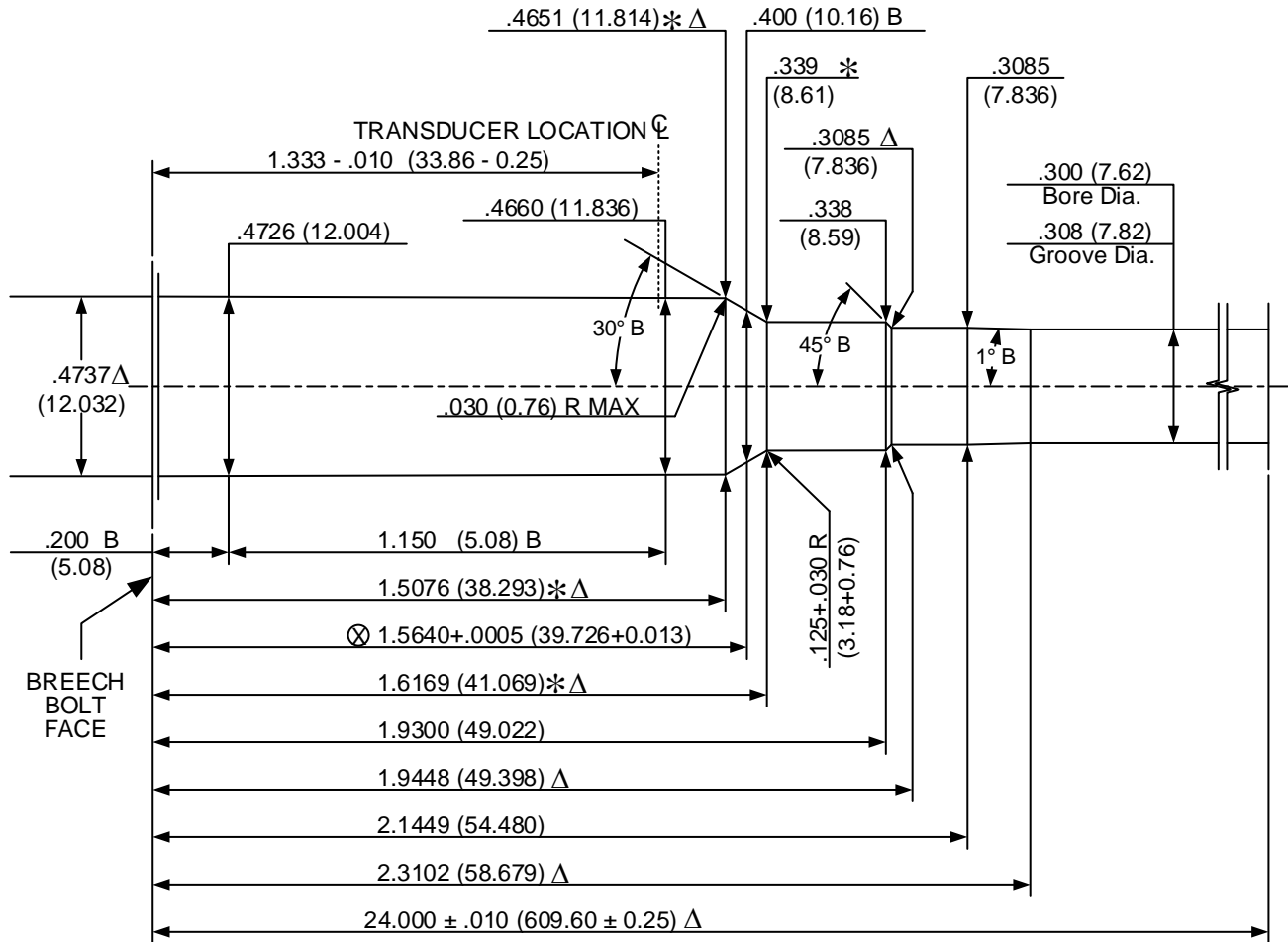

DO NOT SCALE FROM DRAWING

NUMBER OF GROOVES: 4
 WIDTH OF GROOVES: .176 + .002 (4.47 + 0.05)
 TWIST RATE: 12.00 (304.8) R.H.
 DIAMETER OF PISTON HOLE: Crusher pressures not established
 TRANSDUCER DIAMETER: .250 (6.35)

LAND AND GROOVE DIMENSIONS TO BE
 WITHIN TOLERANCES THROUGHOUT
 LENGTH OF BARREL.

UNLESS OTHERWISE NOTED,
 ALL DIAMETERS +.0005 (0.013)
 LENGTH TOLERANCE + .005 (0.13)

NOTE:

B = BASIC Δ = REFERENCE DIMENSION ⊗ = HEADSPACE DIMENSION
 * DIMENSIONS ARE TO INTERSECTIONS OF LINES (XX.XX) = MILLIMETERS
 ALL CALCULATIONS APPLY AT MAXIMUM MATERIAL CONDITION (MMC)

30-06 Springfield V&P Test Barrel

Issued: 05/20/1980

Revised: 09/05/2005

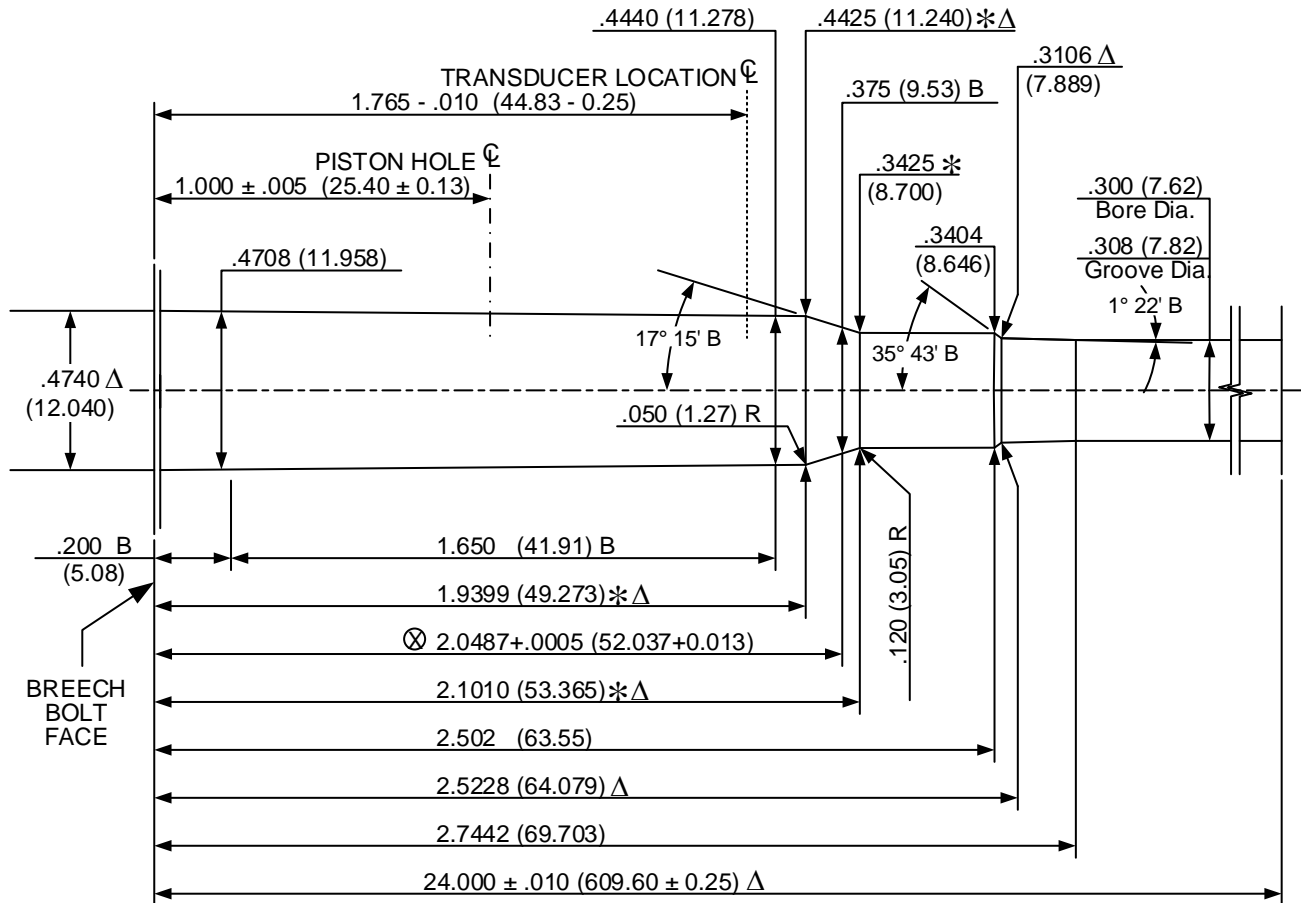

DO NOT SCALE FROM DRAWING

NUMBER OF GROOVES: 4
 WIDTH OF GROOVES: .1767 + .0020 (4.488 + 0.051)
 TWIST RATE: 10.00 (254.0) R.H.
 DIAMETER OF PISTON HOLE: .206 (5.23)
 TRANSDUCER DIAMETER: .250 (6.35)

LAND AND GROOVE DIMENSIONS TO BE
 WITHIN TOLERANCES THROUGHOUT
 LENGTH OF BARREL.

UNLESS OTHERWISE NOTED,
 ALL DIAMETERS +.0005 (0.013)
 LENGTH TOLERANCE + .005 (0.13)

NOTE:

B = BASIC Δ = REFERENCE DIMENSION \varnothing = HEADSPACE DIMENSION
 * DIMENSIONS ARE TO INTERSECTIONS OF LINES (XX.XX) = MILLIMETERS
 ALL CALCULATIONS APPLY AT MAXIMUM MATERIAL CONDITION (MMC)

30-30 Winchester V&P Test Barrel

Issued: 05/20/1980

Revised: 09/04/2005

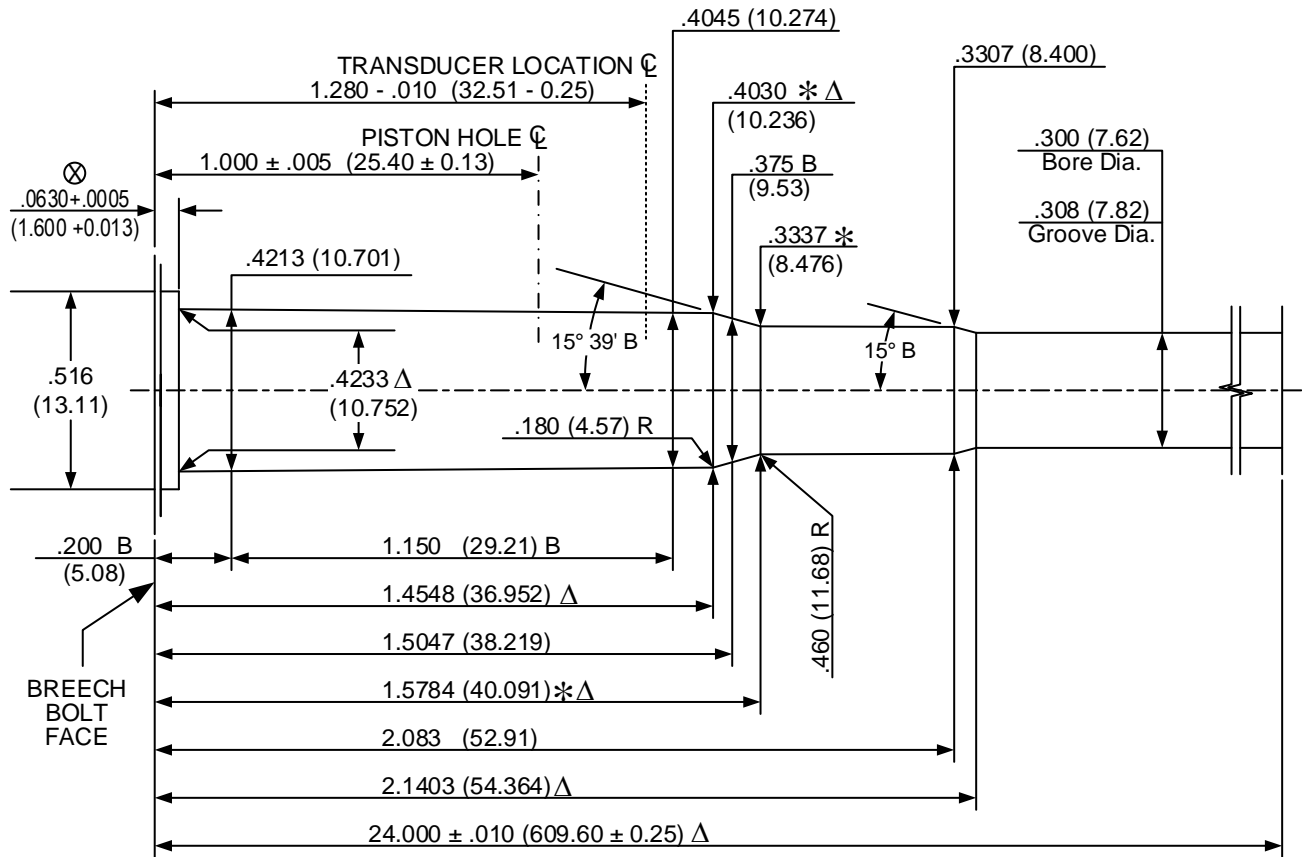

DO NOT SCALE FROM DRAWING

NUMBER OF GROOVES: 6
 WIDTH OF GROOVES: .0942 + .0020 (2.393 + 0.051)
 TWIST RATE: 12.00 (304.8) R.H.
 DIAMETER OF PISTON HOLE: .206 (5.23)
 TRANSDUCER DIAMETER: .250 (6.53)

LAND AND GROOVE DIMENSIONS TO BE WITHIN TOLERANCES THROUGHOUT LENGTH OF BARREL.

UNLESS OTHERWISE NOTED, ALL DIAMETERS +.0005 (0.013) LENGTH TOLERANCE + .005 (0.13)

NOTE:
 B = BASIC Δ = REFERENCE DIMENSION ⊗ = HEADSPACE DIMENSION
 * DIMENSIONS ARE TO INTERSECTIONS OF LINES (XX.XX) = MILLIMETERS
 ALL CALCULATIONS APPLY AT MAXIMUM MATERIAL CONDITION (MMC)

30-40 Krag V&P Test Barrel

Issued: 05/20/1980

Revised: 09/04/2005

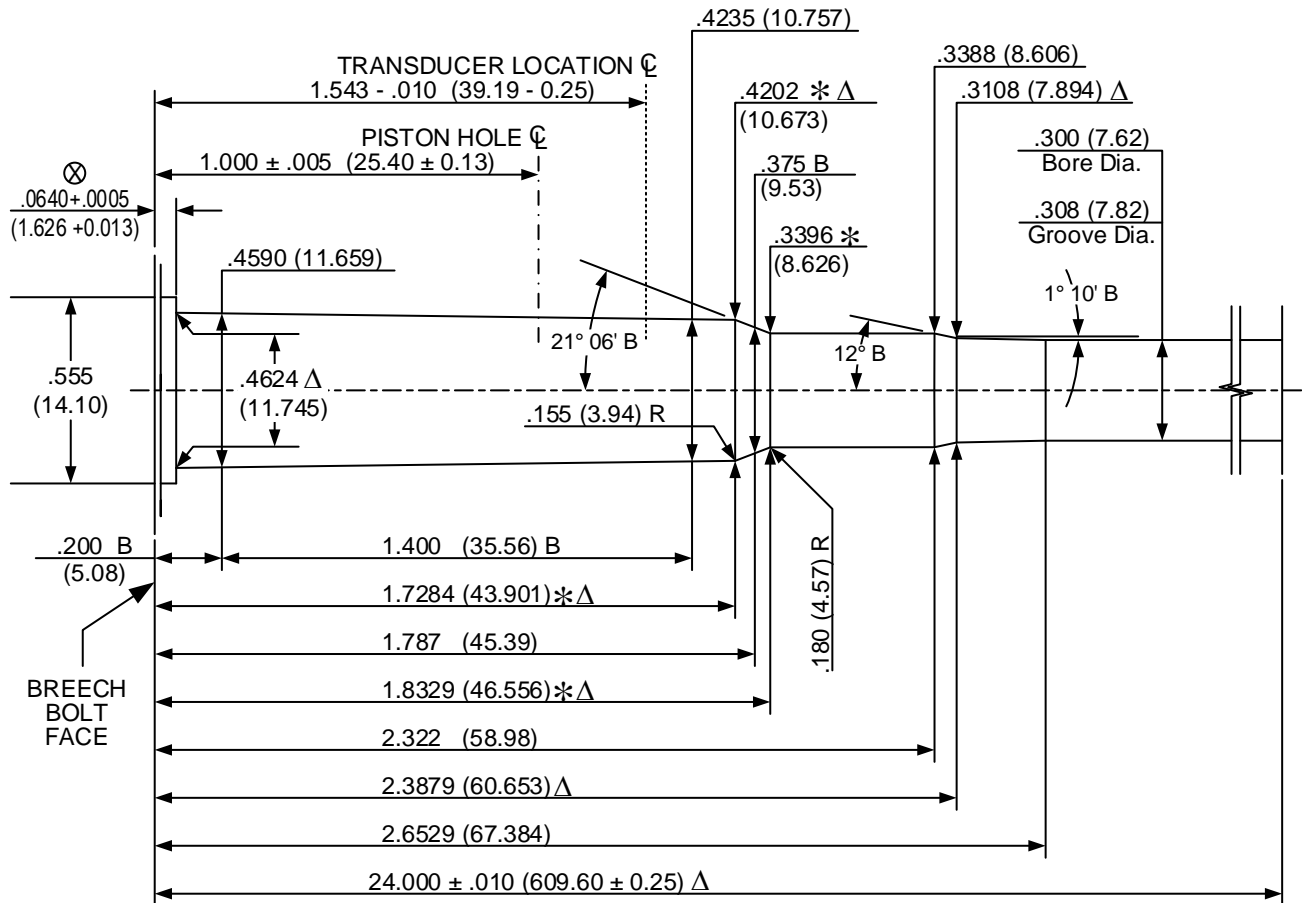

DO NOT SCALE FROM DRAWING

- NUMBER OF GROOVES: 6
- WIDTH OF GROOVES: .094 + .002 (2.39 + 0.05)
- TWIST RATE: 10.00 (254.0) R.H.
- DIAMETER OF PISTON HOLE: .206 (5.23)
- TRANSDUCER DIAMETER: .250 (6.53)

LAND AND GROOVE DIMENSIONS TO BE WITHIN TOLERANCES THROUGHOUT LENGTH OF BARREL.

UNLESS OTHERWISE NOTED, ALL DIAMETERS +.0005 (0.013) LENGTH TOLERANCE + .005 (0.13)

NOTE:

- B = BASIC
- Δ = REFERENCE DIMENSION
- ⊗ = HEADSPACE DIMENSION
- * DIMENSIONS ARE TO INTERSECTIONS OF LINES
- (XX.XX) = MILLIMETERS
- ALL CALCULATIONS APPLY AT MAXIMUM MATERIAL CONDITION (MMC)

300 Holland & Holland Magnum V&P Test Barrel

Issued: 05/20/1980

Revised: 09/05/2005

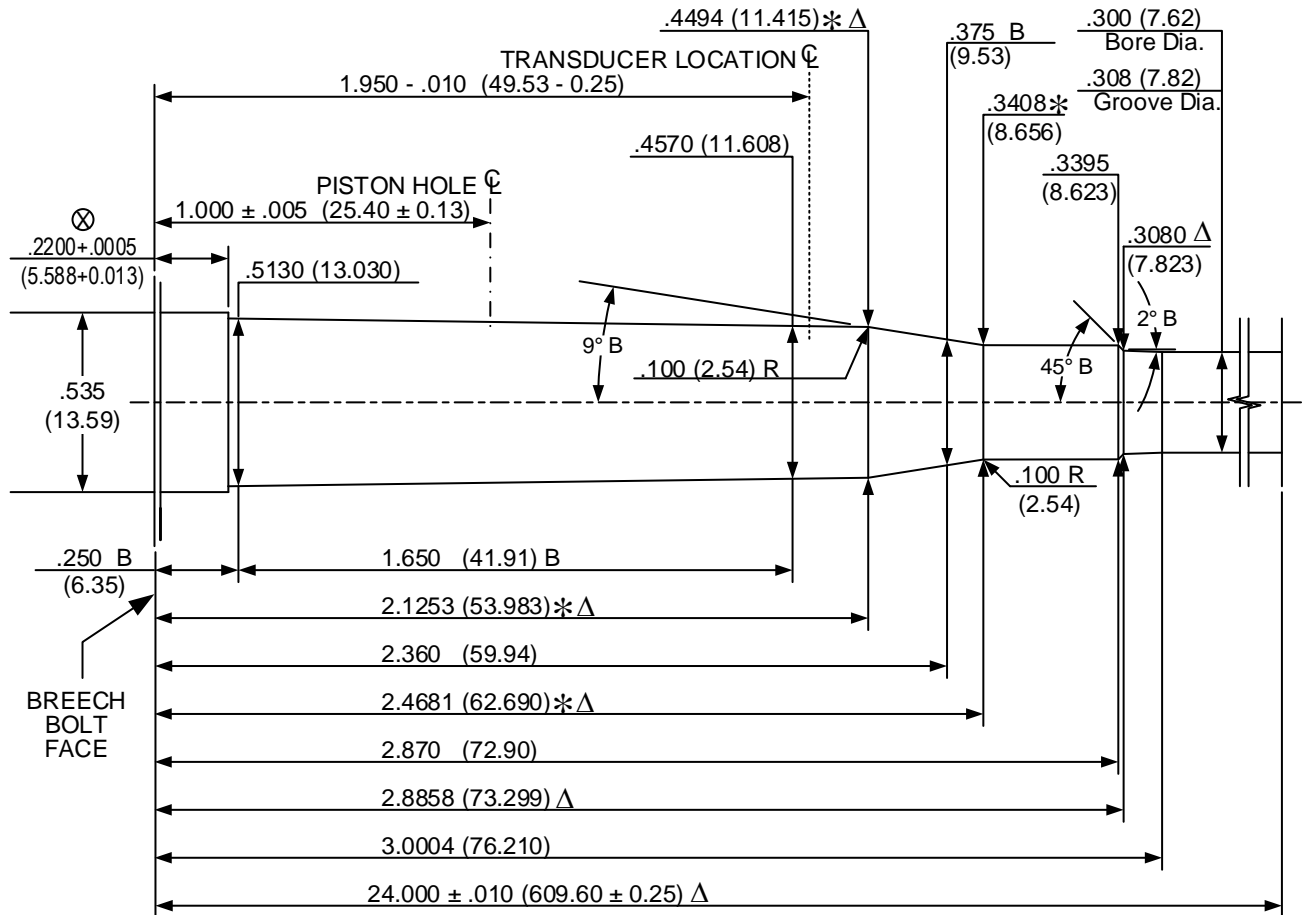

DO NOT SCALE FROM DRAWING

NUMBER OF GROOVES: 4
 WIDTH OF GROOVES: .176 + .002 (4.47 + 0.05)
 TWIST RATE: 10.00 (254.0) R.H.
 DIAMETER OF PISTON HOLE: .206 (5.23)
 TRANSDUCER DIAMETER: .250 (6.35)

LAND AND GROOVE DIMENSIONS TO BE
 WITHIN TOLERANCES THROUGHOUT
 LENGTH OF BARREL.

UNLESS OTHERWISE NOTED,
 ALL DIAMETERS +.0005 (0.013)
 LENGTH TOLERANCE + .005 (0.13)

NOTE:

B = BASIC Δ = REFERENCE DIMENSION ⊗ = HEADSPACE DIMENSION
 * DIMENSIONS ARE TO INTERSECTIONS OF LINES (XX.XX) = MILLIMETERS
 ALL CALCULATIONS APPLY AT MAXIMUM MATERIAL CONDITION (MMC)

300 Remington Short Action Ultra Magnum V&P Test Barrel

Issued: 02/01/2002

Revised: 11/28/2005

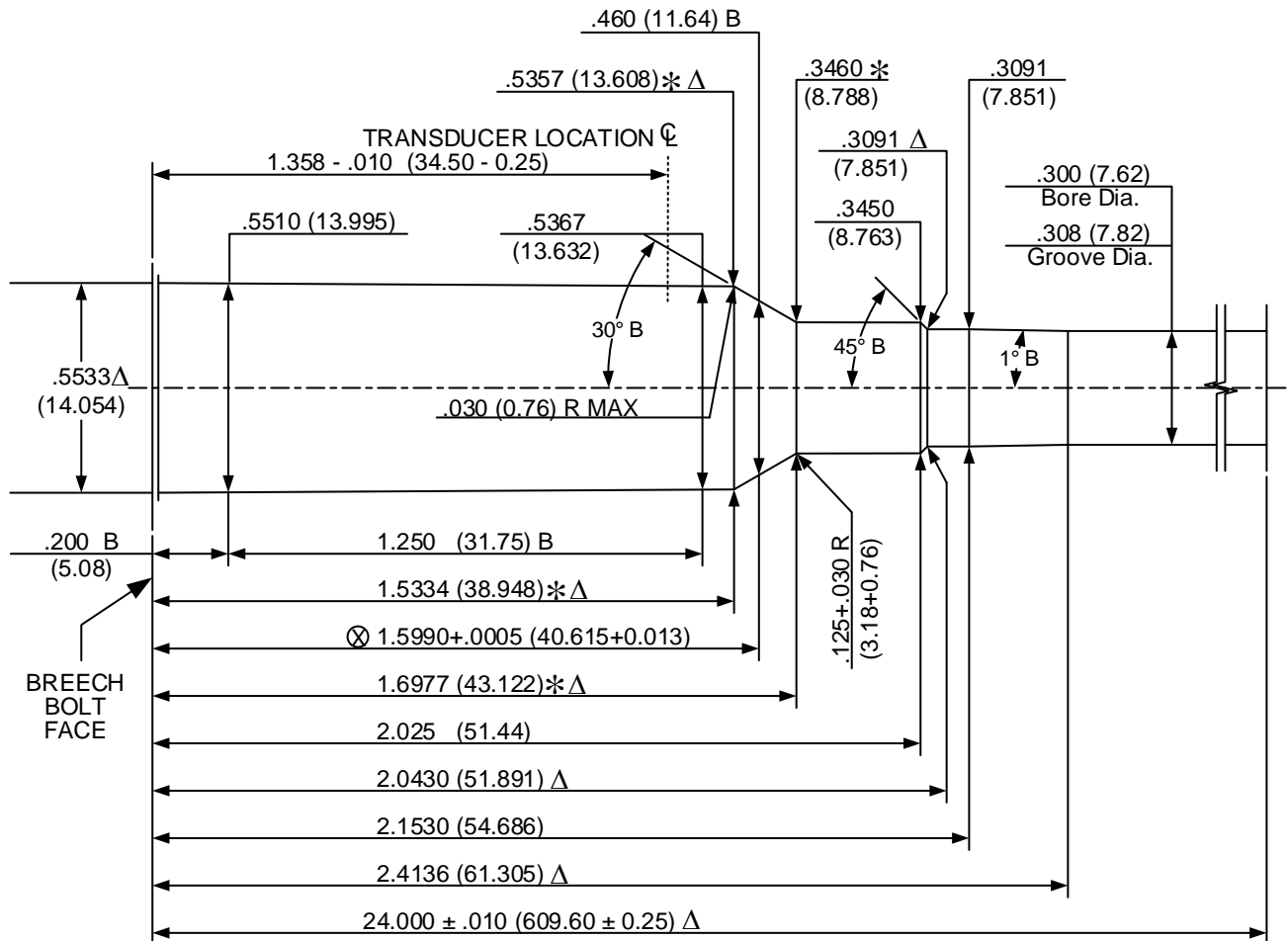

DO NOT SCALE FROM DRAWING

- NUMBER OF GROOVES: 6
- WIDTH OF GROOVES: .110 + .002 (2.79 + 0.05)
- TWIST RATE: 10.00 (254.0) R.H.
- DIAMETER OF PISTON HOLE: Crusher pressures not established
- TRANSDUCER DIAMETER: .250 (6.35)

LAND AND GROOVE DIMENSIONS TO BE WITHIN TOLERANCES THROUGHOUT LENGTH OF BARREL.

UNLESS OTHERWISE NOTED, ALL DIAMETERS +.0005 (0.013) LENGTH TOLERANCE + .005 (0.13)

NOTE:

- B = BASIC
- Δ = REFERENCE DIMENSION
- ⊗ = HEADSPACE DIMENSION
- * DIMENSIONS ARE TO INTERSECTIONS OF LINES
- (XX.XX) = MILLIMETERS
- ALL CALCULATIONS APPLY AT MAXIMUM MATERIAL CONDITION (MMC)

300 Remington Ultra Magnum V&P Test Barrel

Issued: 01/07/1999

Revised:

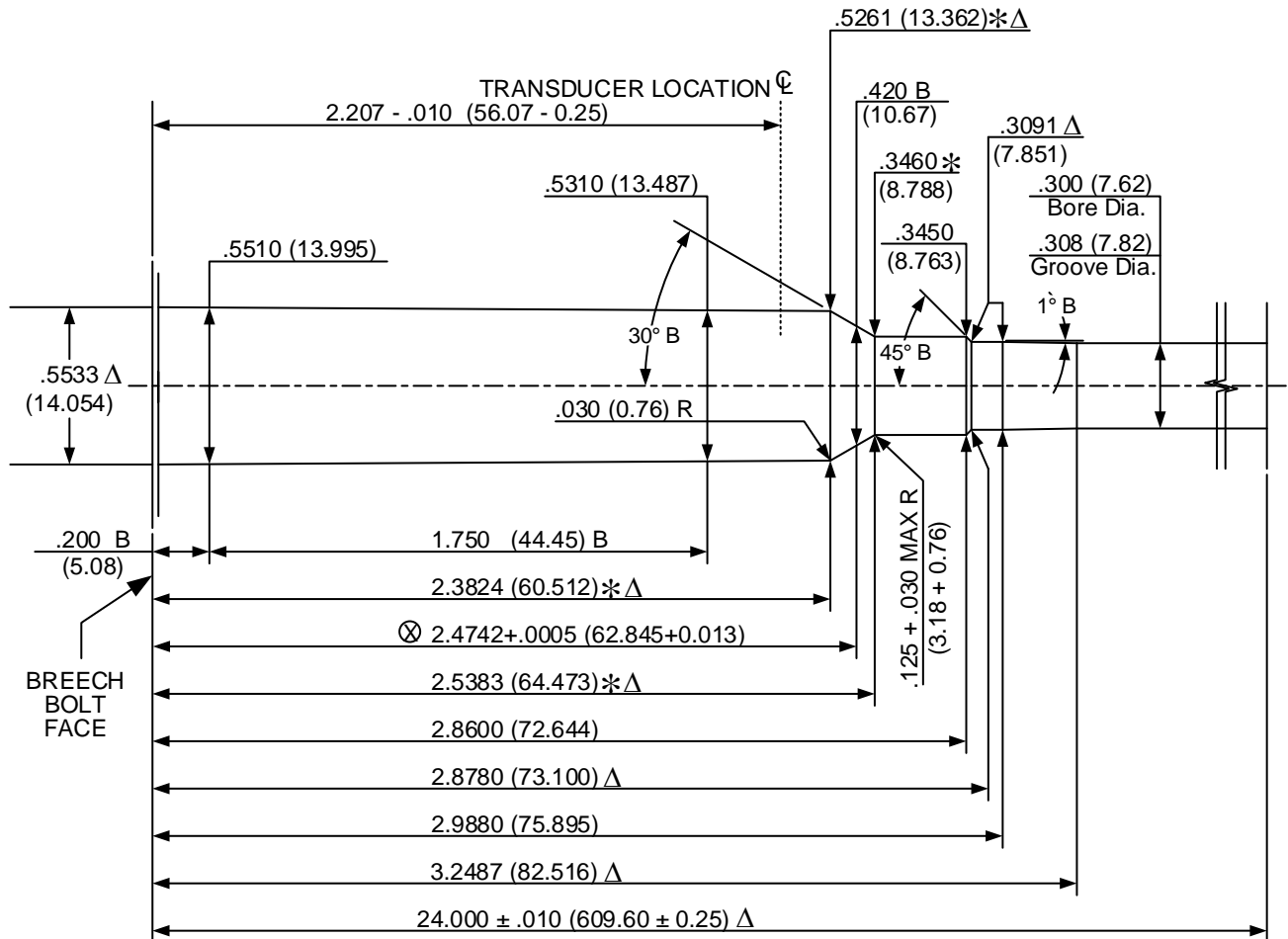

DO NOT SCALE FROM DRAWING

NUMBER OF GROOVES: 6
 WIDTH OF GROOVES: .115 + .002 (2.92 + 0.05)
 TWIST RATE: 10.00 (254.0) R.H.
 DIAMETER OF PISTON HOLE: Crusher pressure not established.
 TRANSDUCER DIAMETER: .250 (6.35)

LAND AND GROOVE DIMENSIONS TO BE
 WITHIN TOLERANCES THROUGHOUT
 LENGTH OF BARREL.

UNLESS OTHERWISE NOTED,
 ALL DIAMETERS +.0005 (0.013)
 LENGTH TOLERANCE + .005 (0.13)

NOTE:

B = BASIC Δ = REFERENCE DIMENSION ⊗ = HEADSPACE DIMENSION
 * DIMENSIONS ARE TO INTERSECTIONS OF LINES (XX.XX) = MILLIMETERS
 ALL CALCULATIONS APPLY AT MAXIMUM MATERIAL CONDITION (MMC)

300 Ruger Compact Magnum V&P Test Barrel

Issued: 12/30/2008

Revised: - - / - - / - - - -

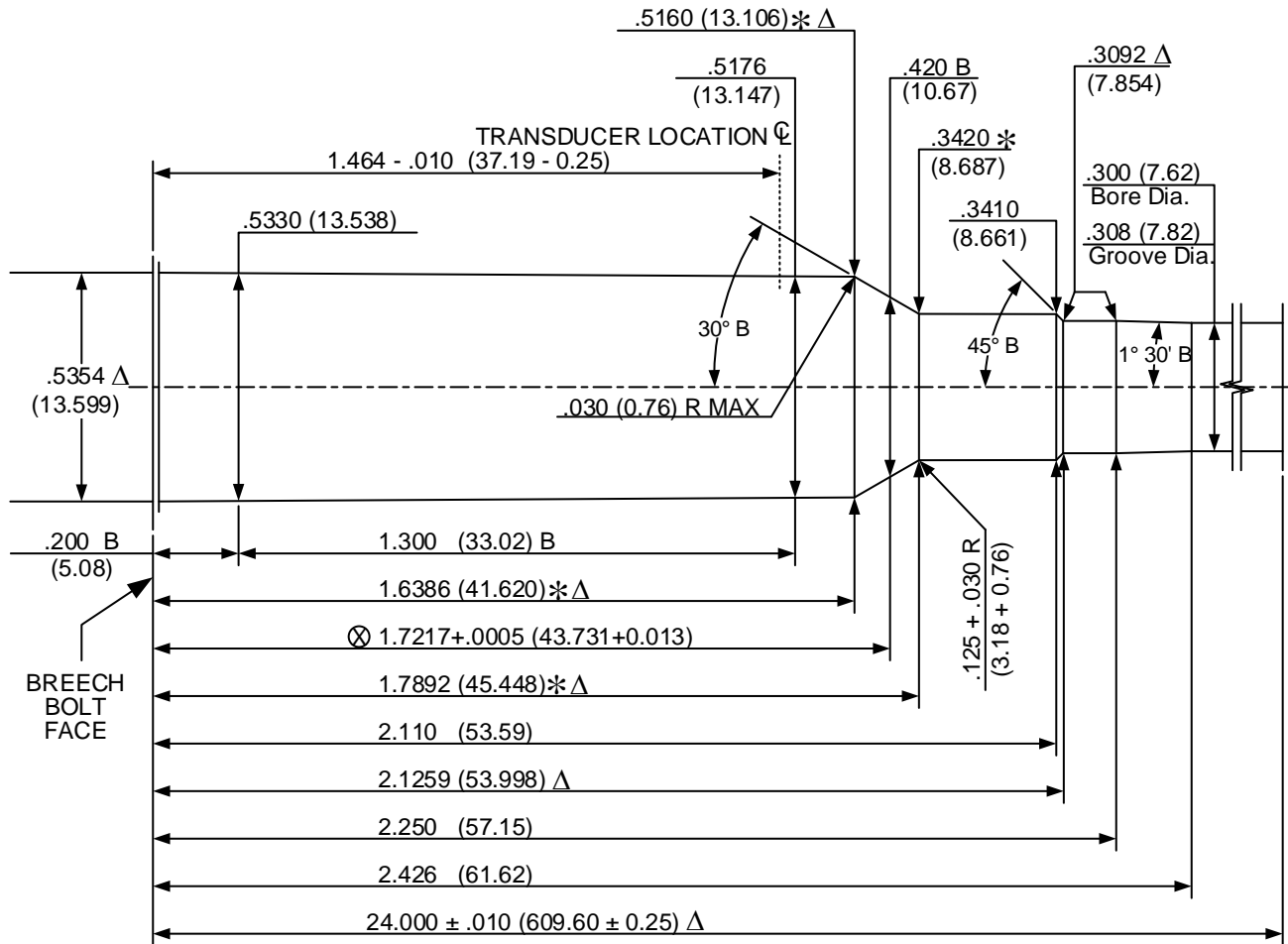

DO NOT SCALE FROM DRAWING

NUMBER OF GROOVES: 6
 WIDTH OF GROOVES: .110 + .002 (2.79 + 0.051)
 TWIST RATE: 10.00 (254.0) R.H.
 DIAMETER OF PISTON HOLE: Crusher pressures not established
 TRANSDUCER DIAMETER: .250 (6.35)

LAND AND GROOVE DIMENSIONS TO BE
 WITHIN TOLERANCES THROUGHOUT
 LENGTH OF BARREL.

UNLESS OTHERWISE NOTED,
 ALL DIAMETERS +.0005 (0.013)
 LENGTH TOLERANCE + .005 (0.13)

NOTE:

B = BASIC Δ = REFERENCE DIMENSION ⊗ = HEADSPACE DIMENSION
 * DIMENSIONS ARE TO INTERSECTIONS OF LINES (XX.XX) = MILLIMETERS
 ALL CALCULATIONS APPLY AT MAXIMUM MATERIAL CONDITION (MMC)

300 Savage V&P Test Barrel

Issued: 05/20/1980

Revised: 09/04/2005

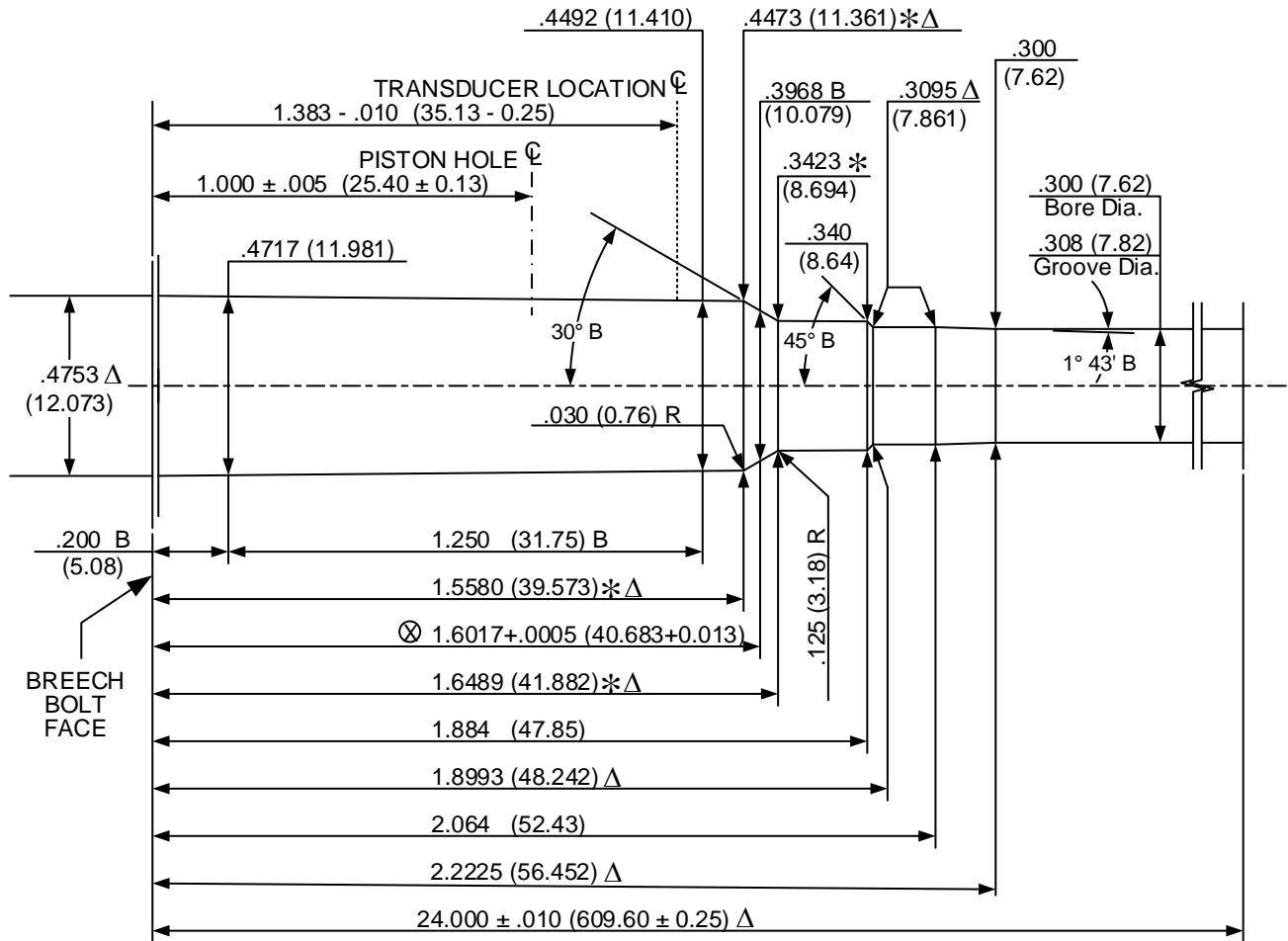

DO NOT SCALE FROM DRAWING

- NUMBER OF GROOVES: 6
- WIDTH OF GROOVES: .095 + .002 (2.41 + 0.05)
- TWIST RATE: 12.00 (304.8) R.H.
- DIAMETER OF PISTON HOLE: .206 (5.23)
- TRANSDUCER DIAMETER: .250 (6.35)

LAND AND GROOVE DIMENSIONS TO BE WITHIN TOLERANCES THROUGHOUT LENGTH OF BARREL.

UNLESS OTHERWISE NOTED, ALL DIAMETERS +.0005 (0.013) LENGTH TOLERANCE + .005 (0.13)

NOTE:

- B = BASIC
- Δ = REFERENCE DIMENSION
- ⊗ = HEADSPACE DIMENSION
- * DIMENSIONS ARE TO INTERSECTIONS OF LINES
- (XX.XX) = MILLIMETERS
- ALL CALCULATIONS APPLY AT MAXIMUM MATERIAL CONDITION (MMC)

300 Weatherby Magnum V&P Test Barrel

Issued: 02/01/1990

Revised: 09/04/2005

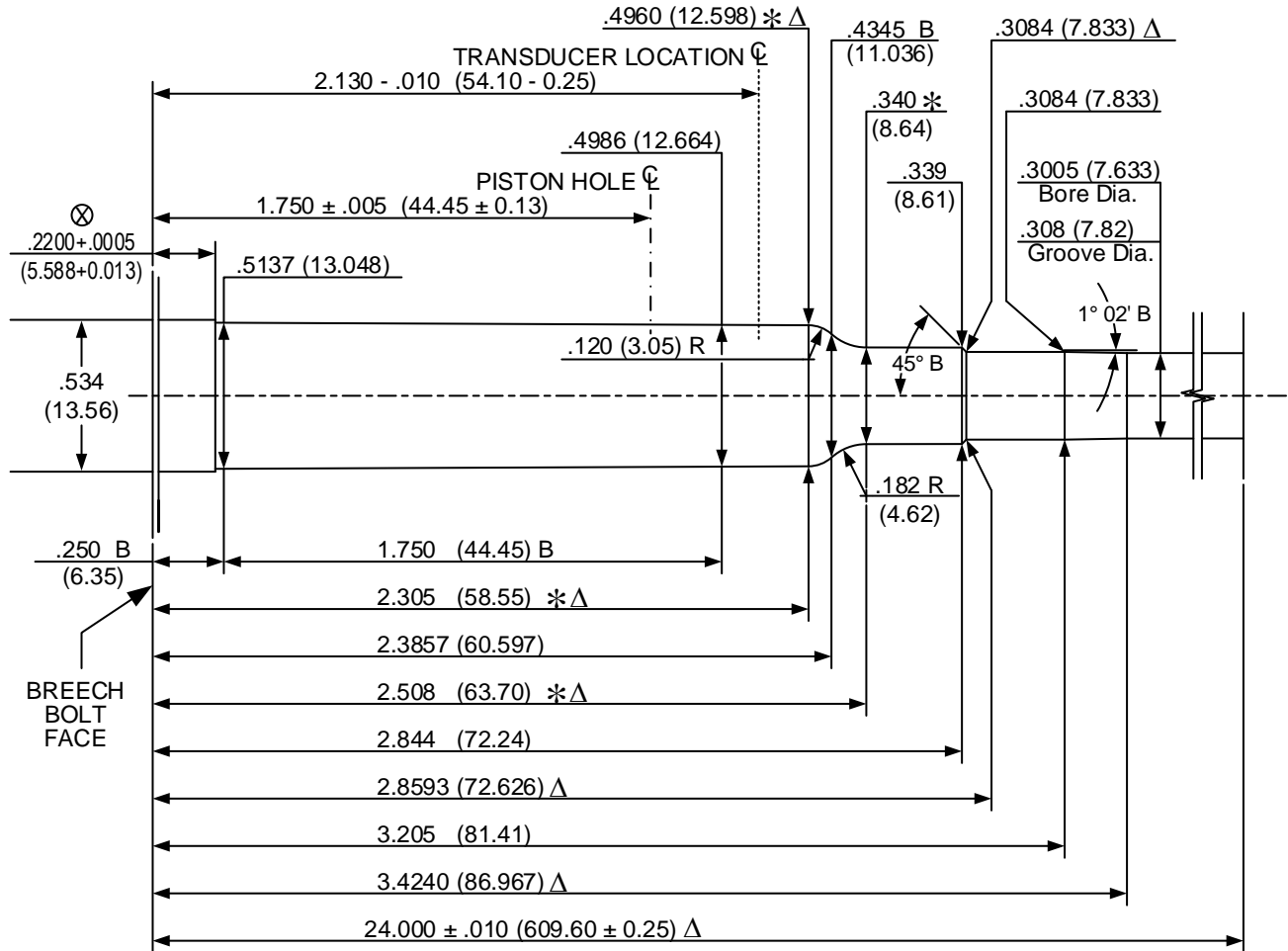

DO NOT SCALE FROM DRAWING

- NUMBER OF GROOVES: 6
- WIDTH OF GROOVES: .118 + .002 (3.00 + 0.05)
- TWIST RATE: 10.00 (254.0) R.H.
- DIAMETER OF PISTON HOLE: .206 (5.23)
- TRANSDUCER DIAMETER: .250 (6.35)

LAND AND GROOVE DIMENSIONS TO BE WITHIN TOLERANCES THROUGHOUT LENGTH OF BARREL.

UNLESS OTHERWISE NOTED, ALL DIAMETERS +.0005 (0.013) LENGTH TOLERANCE + .005 (0.13)

NOTE:

- B = BASIC Δ = REFERENCE DIMENSION ⊗ = HEADSPACE DIMENSION
- * DIMENSIONS ARE TO INTERSECTIONS OF LINES (XX.XX) = MILLIMETERS
- ALL CALCULATIONS APPLY AT MAXIMUM MATERIAL CONDITION (MMC)

300 Winchester Magnum V&P Test Barrel

Issued: 05/20/1980

Revised: 09/04/2005

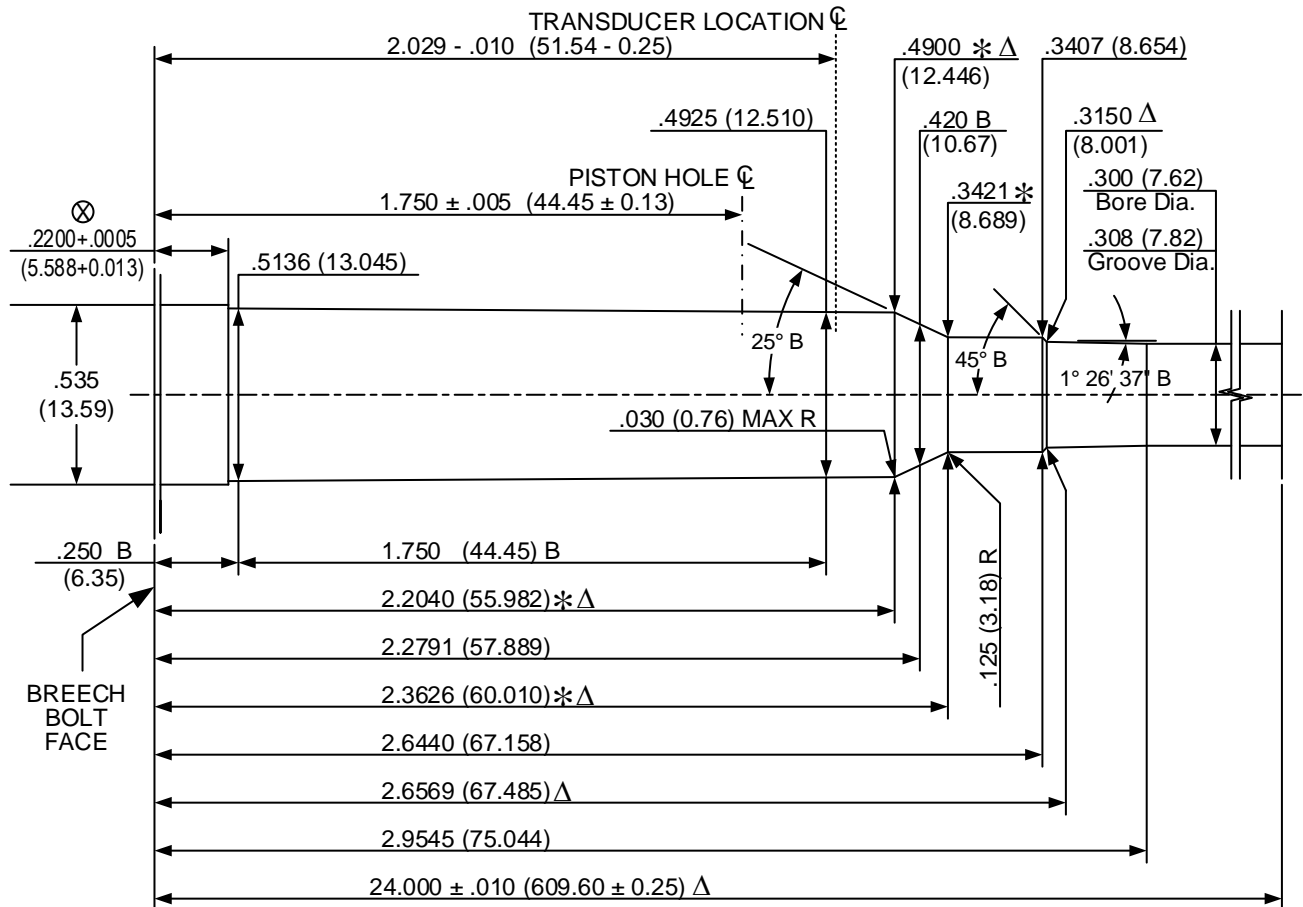

DO NOT SCALE FROM DRAWING

- NUMBER OF GROOVES: 6
- WIDTH OF GROOVES: .110 + .002 (2.79 + 0.05)
- TWIST RATE: 10.00 (254.0) R.H.
- DIAMETER OF PISTON HOLE: .206 (5.23)
- TRANSDUCER DIAMETER: .250 (6.35)

LAND AND GROOVE DIMENSIONS TO BE WITHIN TOLERANCES THROUGHOUT LENGTH OF BARREL.

UNLESS OTHERWISE NOTED, ALL DIAMETERS +.0005 (0.013) LENGTH TOLERANCE + .005 (0.13)

NOTE:

- B = BASIC
- Δ = REFERENCE DIMENSION
- ⊗ = HEADSPACE DIMENSION
- * DIMENSIONS ARE TO INTERSECTIONS OF LINES
- (XX.XX) = MILLIMETERS
- ALL CALCULATIONS APPLY AT MAXIMUM MATERIAL CONDITION (MMC)

300 Winchester Short Magnum V&P Test Barrel

Issued: 06/13/2001

Revised: 11/28/2005

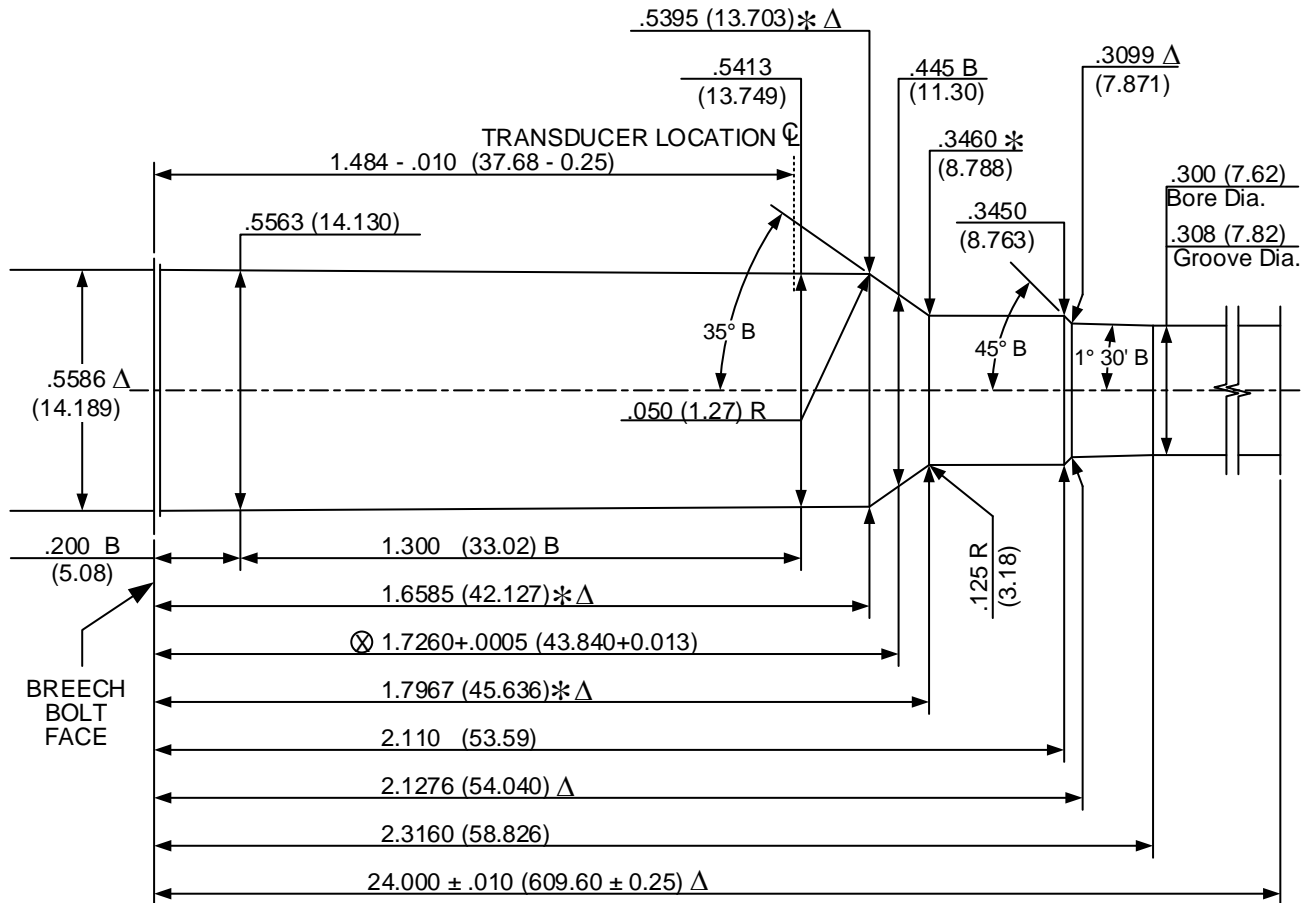

DO NOT SCALE FROM DRAWING

- NUMBER OF GROOVES: 4
- WIDTH OF GROOVES: .1767 + .0020 (4.488 + 0.051)
- TWIST RATE: 10.00 (254.0) R.H.
- DIAMETER OF PISTON HOLE: Crusher pressures not established
- TRANSDUCER DIAMETER: .250 (6.35)

LAND AND GROOVE DIMENSIONS TO BE WITHIN TOLERANCES THROUGHOUT LENGTH OF BARREL.

UNLESS OTHERWISE NOTED, ALL DIAMETERS +.0005 (0.013) LENGTH TOLERANCE + .005 (0.13)

NOTE:

- B = BASIC
- Δ = REFERENCE DIMENSION
- ⊗ = HEADSPACE DIMENSION
- * DIMENSIONS ARE TO INTERSECTIONS OF LINES
- (XX.XX) = MILLIMETERS
- ALL CALCULATIONS APPLY AT MAXIMUM MATERIAL CONDITION (MMC)

303 British V&P Test Barrel

Issued: 05/20/1980

Revised: 12/09/2005

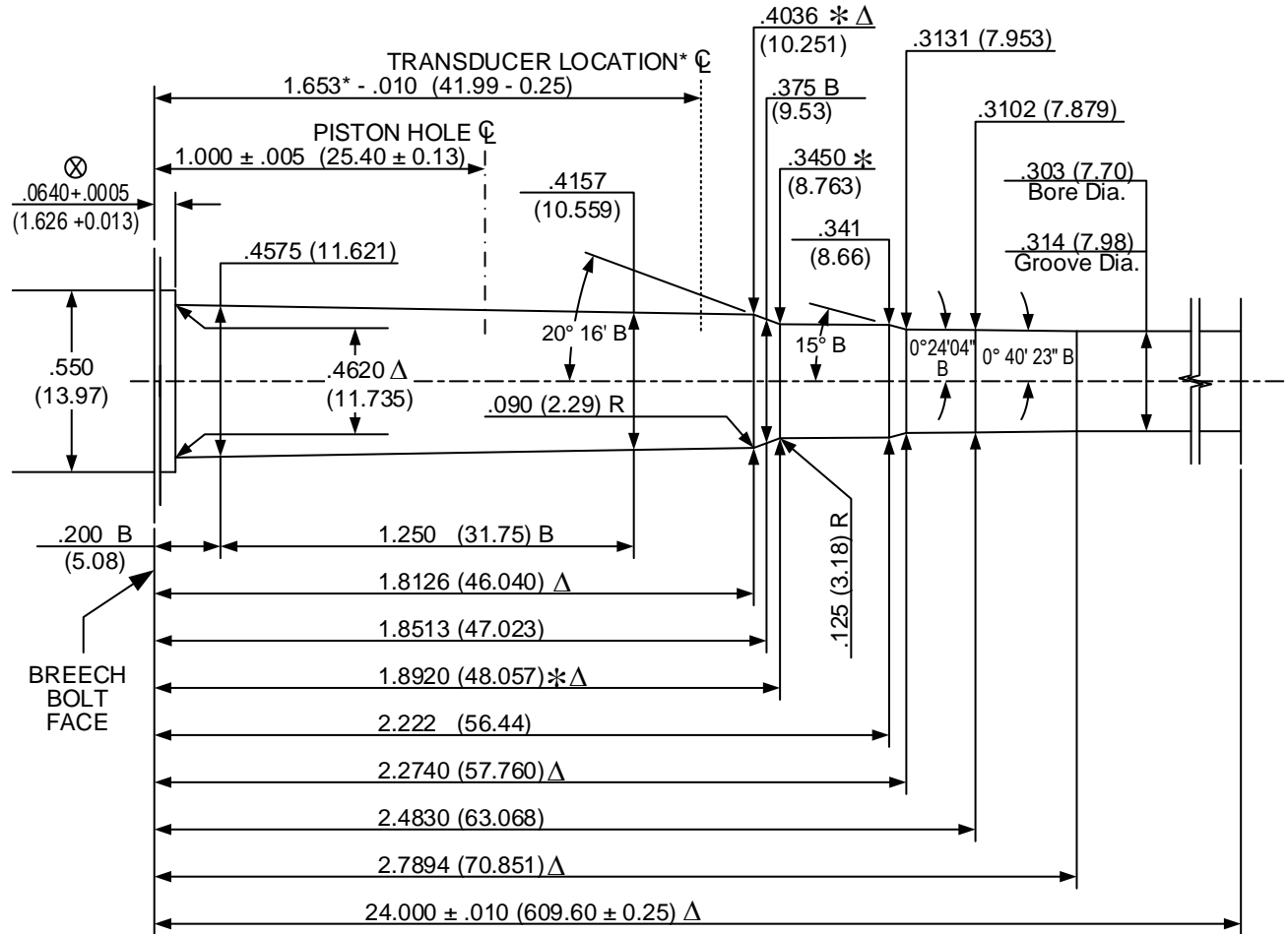

NOTE:

* - This transducer location is recognized as being inconsistent with the stated criteria for transducer centerline.

DO NOT SCALE FROM DRAWING

- NUMBER OF GROOVES: 5
- WIDTH OF GROOVES: .0936 + .0020 (2.377 + 0.051)
- TWIST RATE: 10.00 (254.0) L.H.
- DIAMETER OF PISTON HOLE: .206 (5.23)
- TRANSDUCER DIAMETER: .250 (6.53)

LAND AND GROOVE DIMENSIONS TO BE WITHIN TOLERANCES THROUGHOUT LENGTH OF BARREL.

UNLESS OTHERWISE NOTED, ALL DIAMETERS +.0005 (0.013) LENGTH TOLERANCE + .005 (0.13)

NOTE:

B = BASIC Δ = REFERENCE DIMENSION ⊗ = HEADSPACE DIMENSION
 * DIMENSIONS ARE TO INTERSECTIONS OF LINES (XX.XX) = MILLIMETERS
 ALL CALCULATIONS APPLY AT MAXIMUM MATERIAL CONDITION (MMC)

307 Winchester V&P Test Barrel

Issued: 11/08/1983

Revised: 09/05/2005

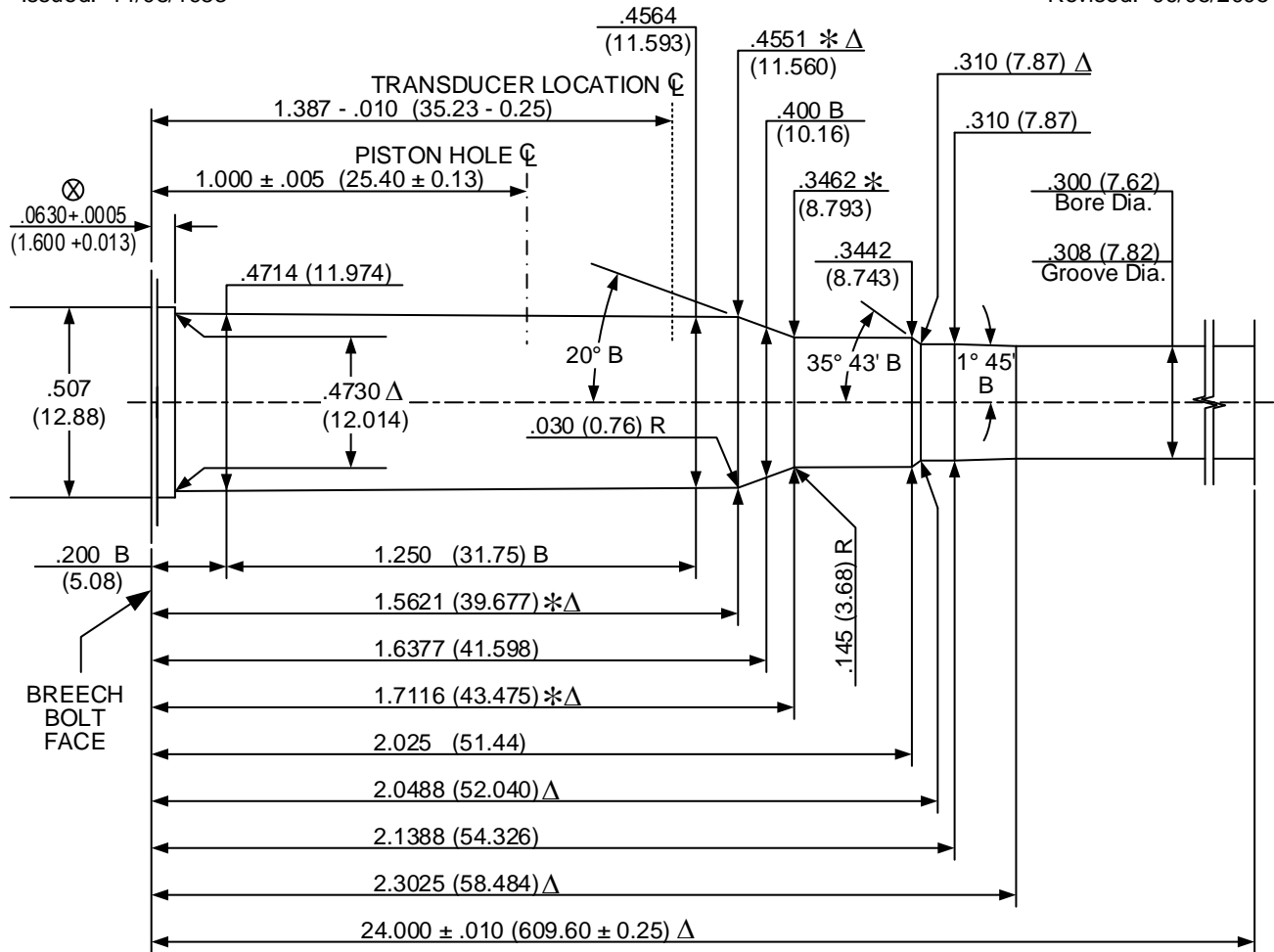

DO NOT SCALE FROM DRAWING

- NUMBER OF GROOVES: 4
- WIDTH OF GROOVES: .176 + .002 (4.47 + 0.05)
- TWIST RATE: 12.00 (304.8) R.H.
- DIAMETER OF PISTON HOLE: .206 (5.23)
- TRANSDUCER DIAMETER: .250 (6.53)

LAND AND GROOVE DIMENSIONS TO BE WITHIN TOLERANCES THROUGHOUT LENGTH OF BARREL.

UNLESS OTHERWISE NOTED, ALL DIAMETERS +.0005 (0.013) LENGTH TOLERANCE + .005 (0.13)

NOTE:

B = BASIC Δ = REFERENCE DIMENSION ⊗ = HEADSPACE DIMENSION
 * DIMENSIONS ARE TO INTERSECTIONS OF LINES (XX.XX) = MILLIMETERS
 ALL CALCULATIONS APPLY AT MAXIMUM MATERIAL CONDITION (MMC)

308 Marlin Express V&P Test Barrel

Issued: 01/05/2007

Revised: -/-/-/-

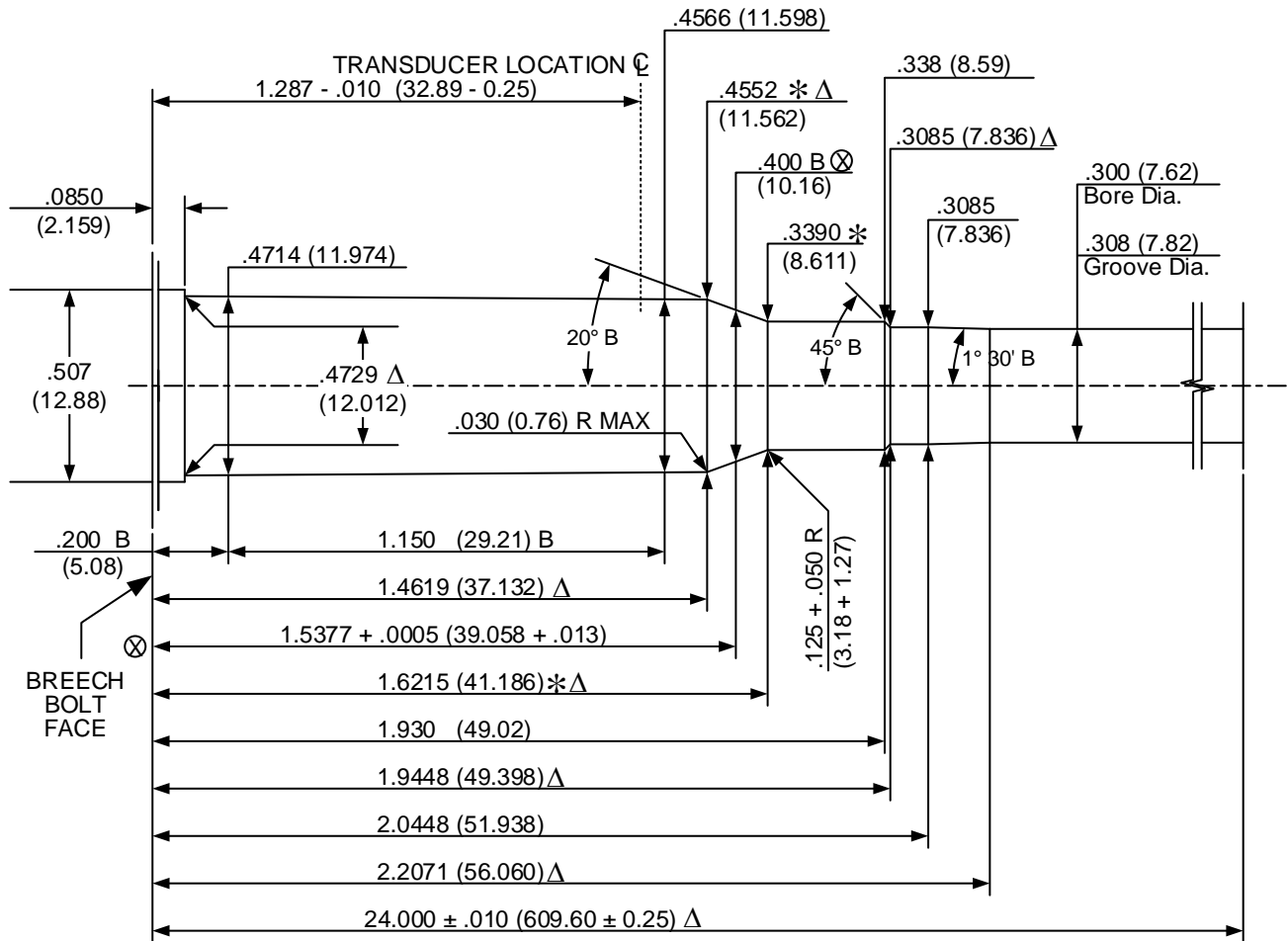

DO NOT SCALE FROM DRAWING

NUMBER OF GROOVES: 6
 WIDTH OF GROOVES: .0942 + .0020 (2.393 + 0.051)
 TWIST RATE: 12.00 (304.8) R.H.
 DIAMETER OF PISTON HOLE: Crusher pressures not established
 TRANSDUCER DIAMETER: .250 (6.53)

LAND AND GROOVE DIMENSIONS TO BE
 WITHIN TOLERANCES THROUGHOUT
 LENGTH OF BARREL.

UNLESS OTHERWISE NOTED,
 ALL DIAMETERS +.0005 (0.013)
 LENGTH TOLERANCE + .005 (0.13)

NOTE:

B = BASIC Δ = REFERENCE DIMENSION ⊗ = HEADSPACE DIMENSION
 * DIMENSIONS ARE TO INTERSECTIONS OF LINES (XX.XX) = MILLIMETERS
 ALL CALCULATIONS APPLY AT MAXIMUM MATERIAL CONDITION (MMC)

308 Winchester V&P Test Barrel

Issued: 05/20/1980

Revised: 09/05/2005

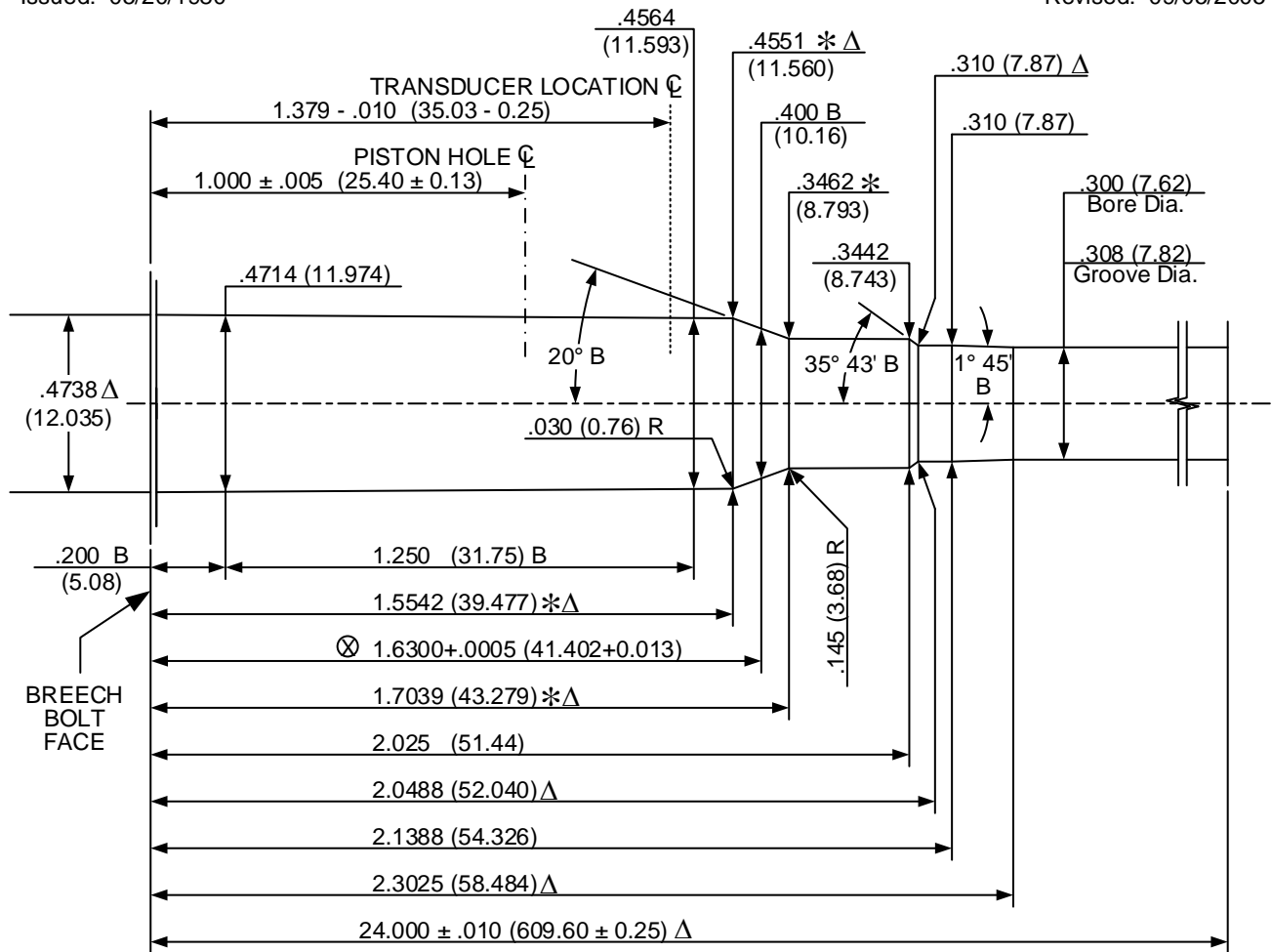

DO NOT SCALE FROM DRAWING

- NUMBER OF GROOVES: 4
- WIDTH OF GROOVES: .176 + .002 (4.47 + 0.05)
- TWIST RATE: 12.00 (304.8) R.H.
- DIAMETER OF PISTON HOLE: .206 (5.23)
- TRANSDUCER DIAMETER: .250 (6.53)

LAND AND GROOVE DIMENSIONS TO BE WITHIN TOLERANCES THROUGHOUT LENGTH OF BARREL.

UNLESS OTHERWISE NOTED, ALL DIAMETERS +.0005 (0.013) LENGTH TOLERANCE + .005 (0.13)

NOTE:

- B = BASIC
- Δ = REFERENCE DIMENSION
- ⊗ = HEADSPACE DIMENSION
- * DIMENSIONS ARE TO INTERSECTIONS OF LINES
- (XX.XX) = MILLIMETERS
- ALL CALCULATIONS APPLY AT MAXIMUM MATERIAL CONDITION (MMC)

32 Winchester Special V&P Test Barrel

Issued: 05/20/1980

Revised: 09/05/2005

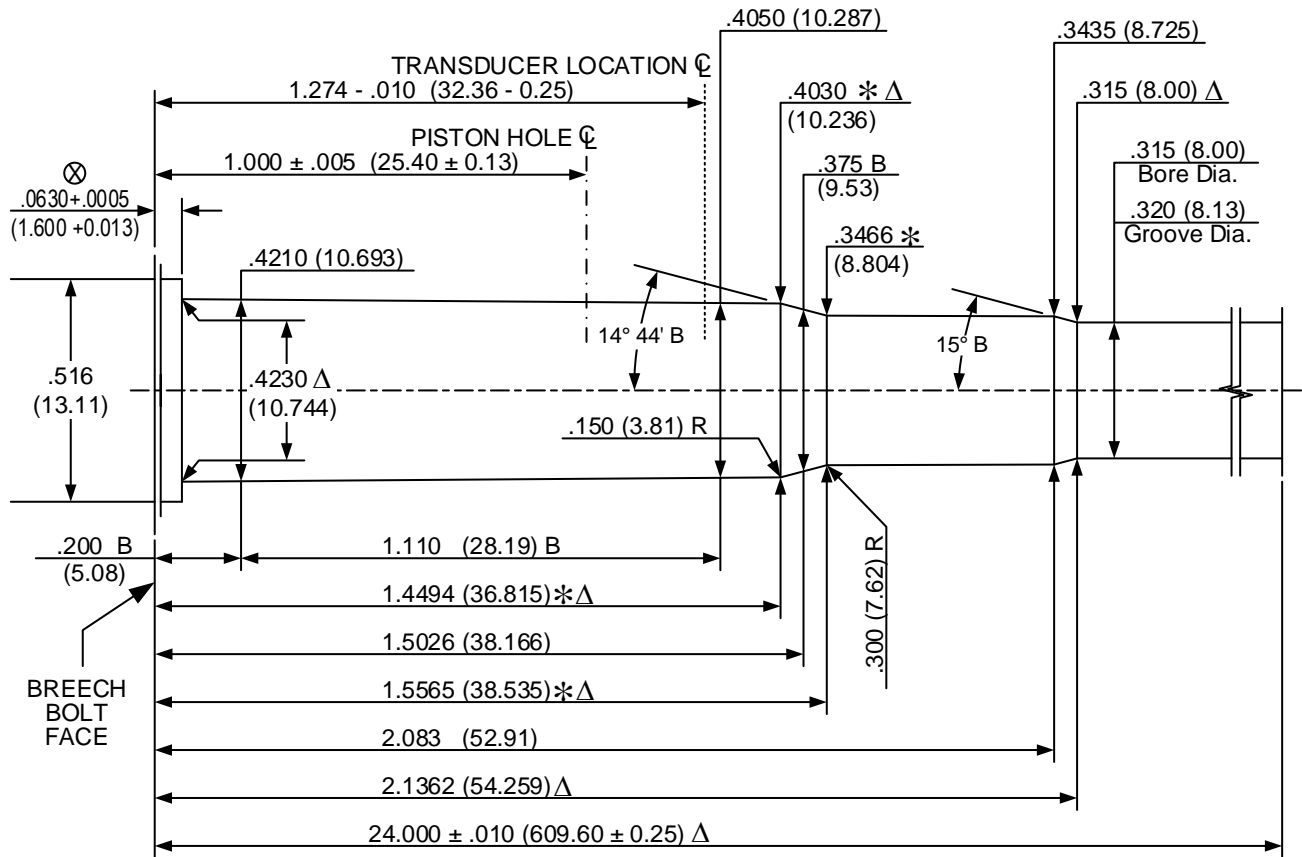

DO NOT SCALE FROM DRAWING

NUMBER OF GROOVES: 6
 WIDTH OF GROOVES: .106 + .002 (2.69 + 0.05)
 TWIST RATE: 16.00 (406.4) R.H.
 DIAMETER OF PISTON HOLE: .206 (5.23)
 TRANSDUCER DIAMETER: .250 (6.53)

LAND AND GROOVE DIMENSIONS TO BE WITHIN TOLERANCES THROUGHOUT LENGTH OF BARREL.

UNLESS OTHERWISE NOTED, ALL DIAMETERS +.0005 (0.013) LENGTH TOLERANCE + .005 (0.13)

NOTE:

B = BASIC Δ = REFERENCE DIMENSION ⊗ = HEADSPACE DIMENSION
 * DIMENSIONS ARE TO INTERSECTIONS OF LINES (XX.XX) = MILLIMETERS
 ALL CALCULATIONS APPLY AT MAXIMUM MATERIAL CONDITION (MMC)

32-20 Winchester V&P Test Barrel

Issued: 05/20/1980

Revised: 09/05/2005

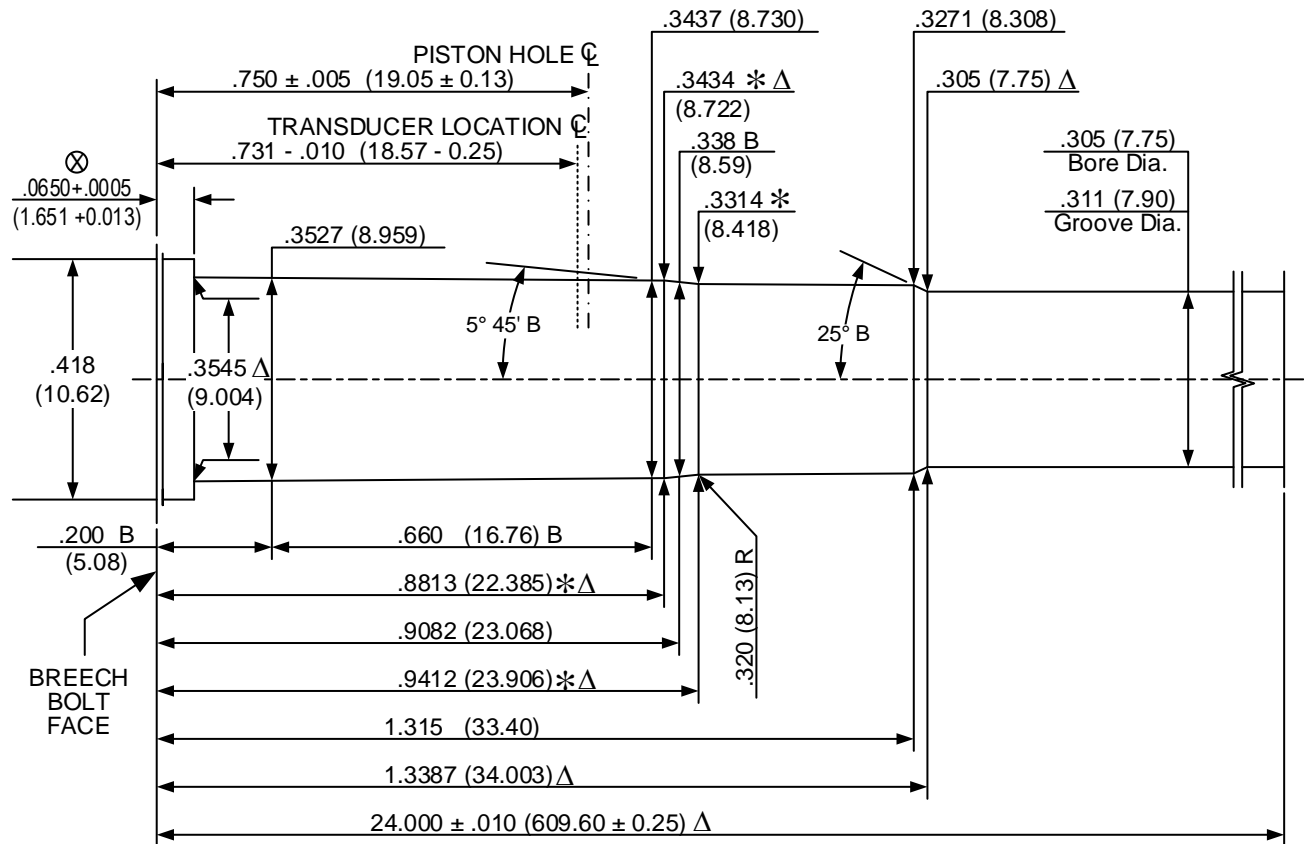

DO NOT SCALE FROM DRAWING

NUMBER OF GROOVES: 6
 WIDTH OF GROOVES: $.0958 + .0020$ (2.433 + 0.051)
 TWIST RATE: 20.00 (508.0) R.H.
 DIAMETER OF PISTON HOLE: $.206$ (5.23)
TRANSDUCER DIAMETER: $.194$ (4.93)

LAND AND GROOVE DIMENSIONS TO BE WITHIN TOLERANCES THROUGHOUT LENGTH OF BARREL.

UNLESS OTHERWISE NOTED, ALL DIAMETERS $+ .0005$ (0.013) LENGTH TOLERANCE $+ .005$ (0.13)

NOTE:
 B = BASIC Δ = REFERENCE DIMENSION \otimes = HEADSPACE DIMENSION
 * DIMENSIONS ARE TO INTERSECTIONS OF LINES (XX.XX) = MILLIMETERS
 ALL CALCULATIONS APPLY AT MAXIMUM MATERIAL CONDITION (MMC)

33 Nosler V&P Test Barrel

Issued: 01/19/2015

Revised: - - / - - / - - - -

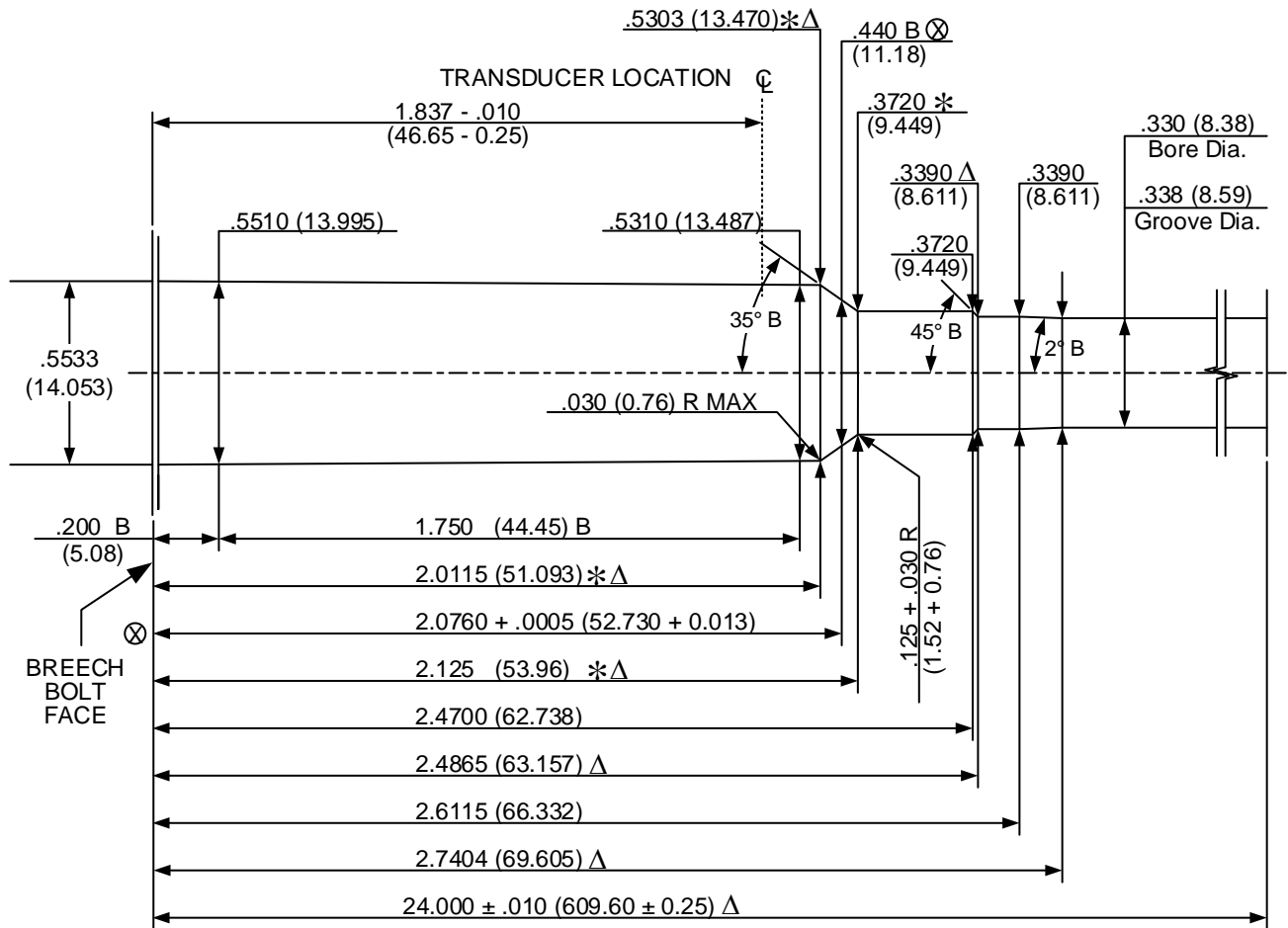

DO NOT SCALE FROM DRAWING

NUMBER OF GROOVES: 6
 WIDTH OF GROOVES: .110 + .002 (2.79 + 0.05)
 TWIST RATE: 10.00 (254.0) R.H.
 DIAMETER OF PISTON HOLE: Crusher pressures not established.
 TRANSDUCER DIAMETER: .250 (6.35)

LAND AND GROOVE DIMENSIONS TO BE
 WITHIN TOLERANCES THROUGHOUT
 LENGTH OF BARREL.

UNLESS OTHERWISE NOTED,
 ALL DIAMETERS +.0005 (0.013)
 LENGTH TOLERANCE + .005 (0.13)

NOTE:

B = BASIC Δ = REFERENCE DIMENSION ⊗ = HEADSPACE DIMENSION
 * DIMENSIONS ARE TO INTERSECTIONS OF LINES (XX.XX) = MILLIMETERS
 ALL CALCULATIONS APPLY AT MAXIMUM MATERIAL CONDITION (MMC)

338 Federal V&P Test Barrel

Issued: 06/28/2006

Revised: - - / - - / - - - -

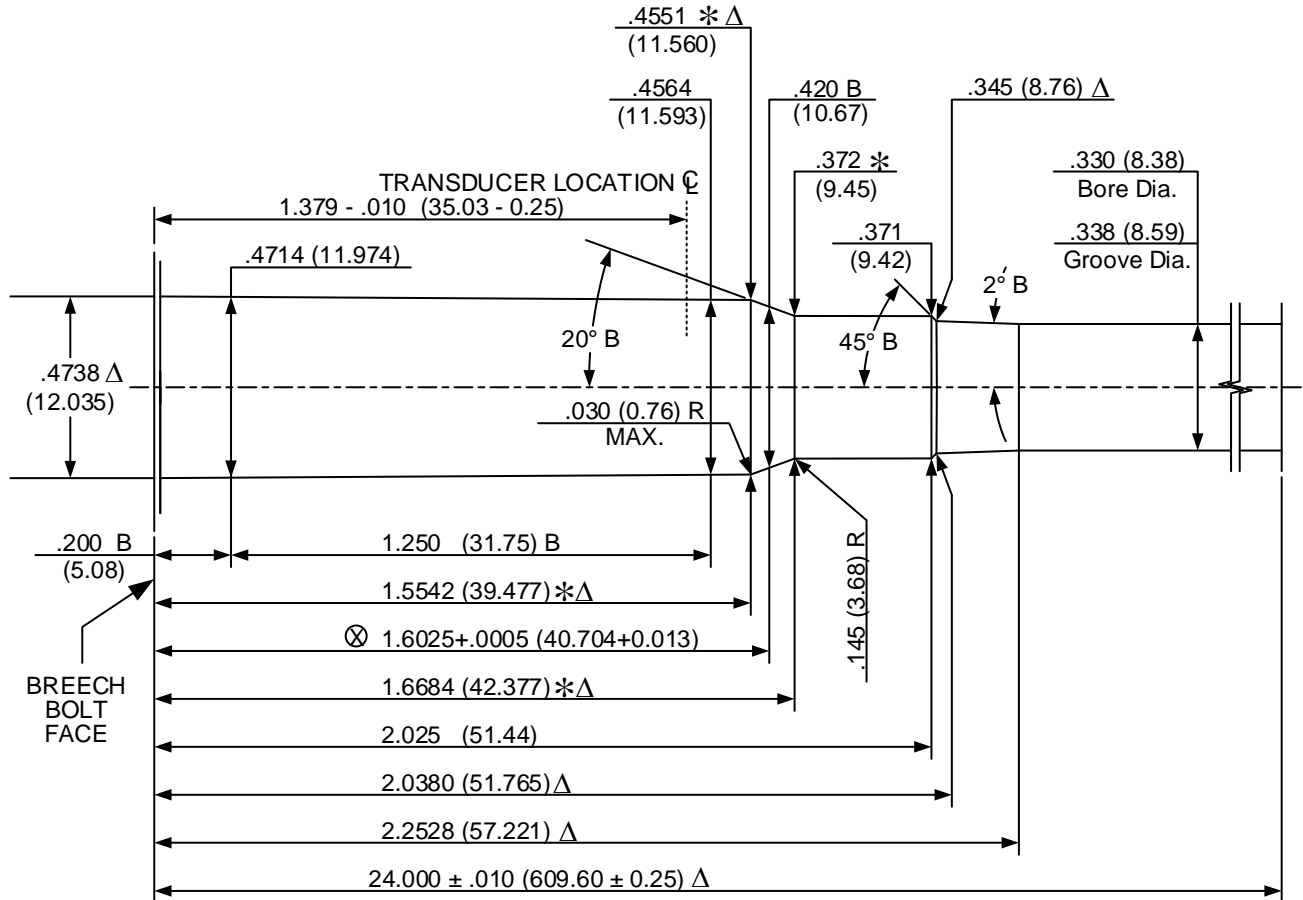

DO NOT SCALE FROM DRAWING

- NUMBER OF GROOVES: 6
- WIDTH OF GROOVES: .110 + .002 (2.79 + 0.05)
- TWIST RATE: 10.00 (254.0) R.H.
- DIAMETER OF PISTON HOLE: Crusher pressures not established.
- TRANSDUCER DIAMETER: .250 (6.53)

LAND AND GROOVE DIMENSIONS TO BE WITHIN TOLERANCES THROUGHOUT LENGTH OF BARREL.

UNLESS OTHERWISE NOTED, ALL DIAMETERS +.0005 (0.013) LENGTH TOLERANCE + .005 (0.13)

NOTE:

B = BASIC Δ = REFERENCE DIMENSION ⊗ = HEADSPACE DIMENSION
 * DIMENSIONS ARE TO INTERSECTIONS OF LINES (XX.XX) = MILLIMETERS
 ALL CALCULATIONS APPLY AT MAXIMUM MATERIAL CONDITION (MMC)

338 Lapua Magnum V&P Test Barrel

Issued: 06/12/2007

Revised:

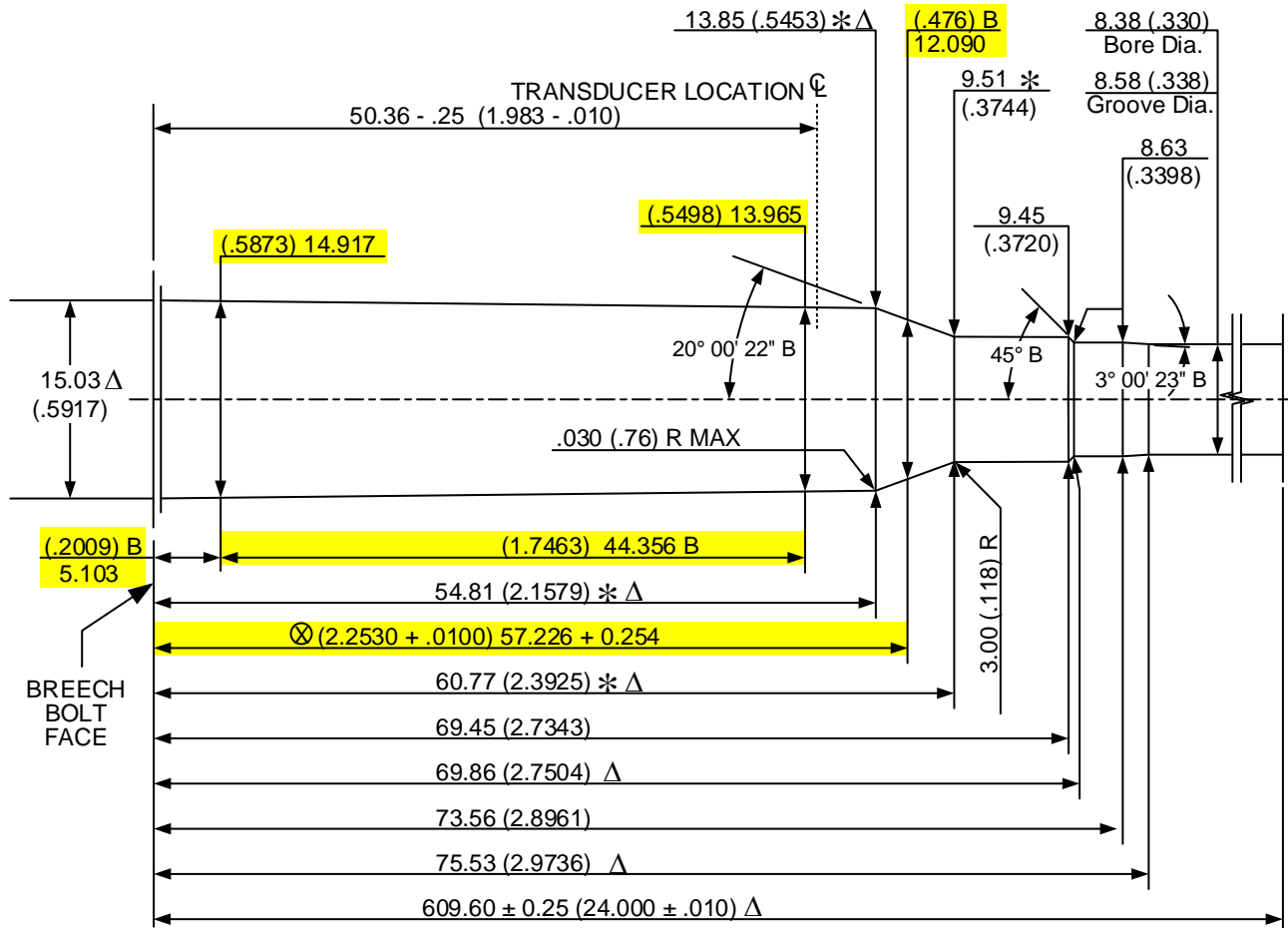

HIGHLIGHTED DIMENSIONS HAVE NO CORRESPONDING C.I.P ANALOG. THE ENGLISH UNITS FOR THESE ARE THE ORIGINAL VALUES; METRIC VALUES ARE CALCULATED AND ROUNDED.

DO NOT SCALE FROM DRAWING

- NUMBER OF GROOVES: 6
- WIDTH OF GROOVES: 2.79 + .05 (.110 + 0.002)
- TWIST RATE: 254.0 (10.00) R.H.
- DIAMETER OF PISTON HOLE: Crusher pressure not established.
- TRANSDUCER DIAMETER: 6.35 (.250)

LAND AND GROOVE DIMENSIONS TO BE WITHIN TOLERANCES THROUGHOUT LENGTH OF BARREL.

UNLESS OTHERWISE NOTED, ALL DIAMETERS +0.013 (.0005) LENGTH TOLERANCE + 0.13 (.005)

NOTE:

- B = BASIC
- Δ = REFERENCE DIMENSION
- ⊗ = HEADSPACE DIMENSION
- * DIMENSIONS ARE TO INTERSECTIONS OF LINES
- (XX.XXXX) = INCHES
- ALL CALCULATIONS APPLY AT MAXIMUM MATERIAL CONDITION (MMC)

METRIC METRIC METRIC

338 Marlin Express V&P Test Barrel

Issued: 06/17/2009

Revised: - - / - - / - - - -

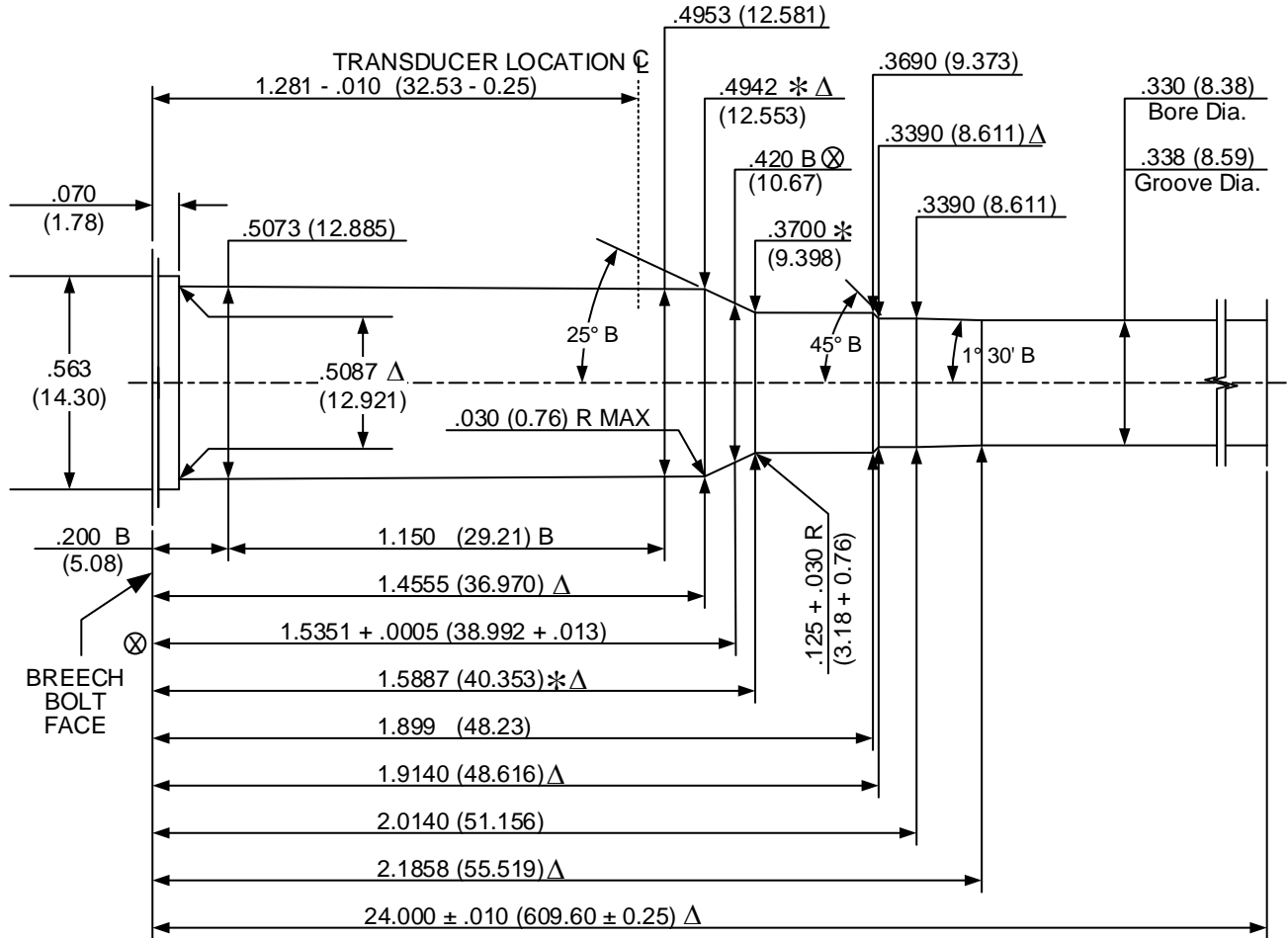

DO NOT SCALE FROM DRAWING

- NUMBER OF GROOVES: 6
- WIDTH OF GROOVES: .110 + .002 (2.79 + 0.05)
- TWIST RATE: 12.00 (304.8) R.H.
- DIAMETER OF PISTON HOLE: Crusher pressures not established
- TRANSDUCER DIAMETER: .250 (6.53)

LAND AND GROOVE DIMENSIONS TO BE WITHIN TOLERANCES THROUGHOUT LENGTH OF BARREL.

UNLESS OTHERWISE NOTED, ALL DIAMETERS +.0005 (0.013) LENGTH TOLERANCE + .005 (0.13)

NOTE:

- B = BASIC Δ = REFERENCE DIMENSION ⊗ = HEADSPACE DIMENSION
- * DIMENSIONS ARE TO INTERSECTIONS OF LINES (XX.XX) = MILLIMETERS
- ALL CALCULATIONS APPLY AT MAXIMUM MATERIAL CONDITION (MMC)

338 Remington Ultra Magnum V&P Test Barrel

Issued: 10/08/1999

Revised:

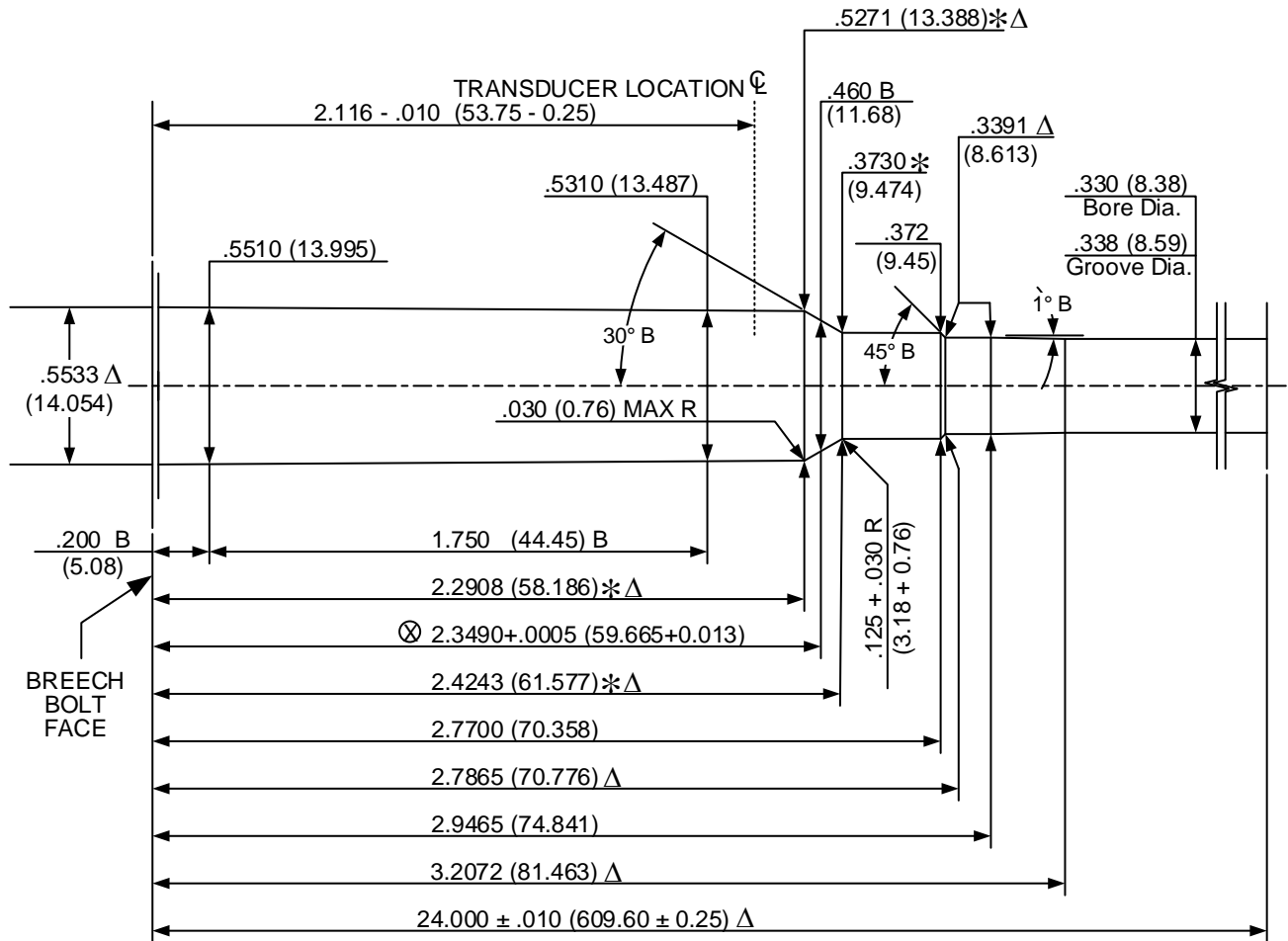

DO NOT SCALE FROM DRAWING

NUMBER OF GROOVES: 6
 WIDTH OF GROOVES: .110 + .002 (2.79 + 0.05)
 TWIST RATE: 10.00 (254.0) R.H.
 DIAMETER OF PISTON HOLE: Crusher pressure not established.
 TRANSDUCER DIAMETER: .250 (6.35)

LAND AND GROOVE DIMENSIONS TO BE
 WITHIN TOLERANCES THROUGHOUT
 LENGTH OF BARREL.

UNLESS OTHERWISE NOTED,
 ALL DIAMETERS +.0005 (0.013)
 LENGTH TOLERANCE + .005 (0.13)

NOTE:

B = BASIC Δ = REFERENCE DIMENSION ⊗ = HEADSPACE DIMENSION
 * DIMENSIONS ARE TO INTERSECTIONS OF LINES (XX.XX) = MILLIMETERS
 ALL CALCULATIONS APPLY AT MAXIMUM MATERIAL CONDITION (MMC)

338 Ruger Compact Magnum V&P Test Barrel

Issued: 01/30/2008

Revised: - - / - - / - - - -

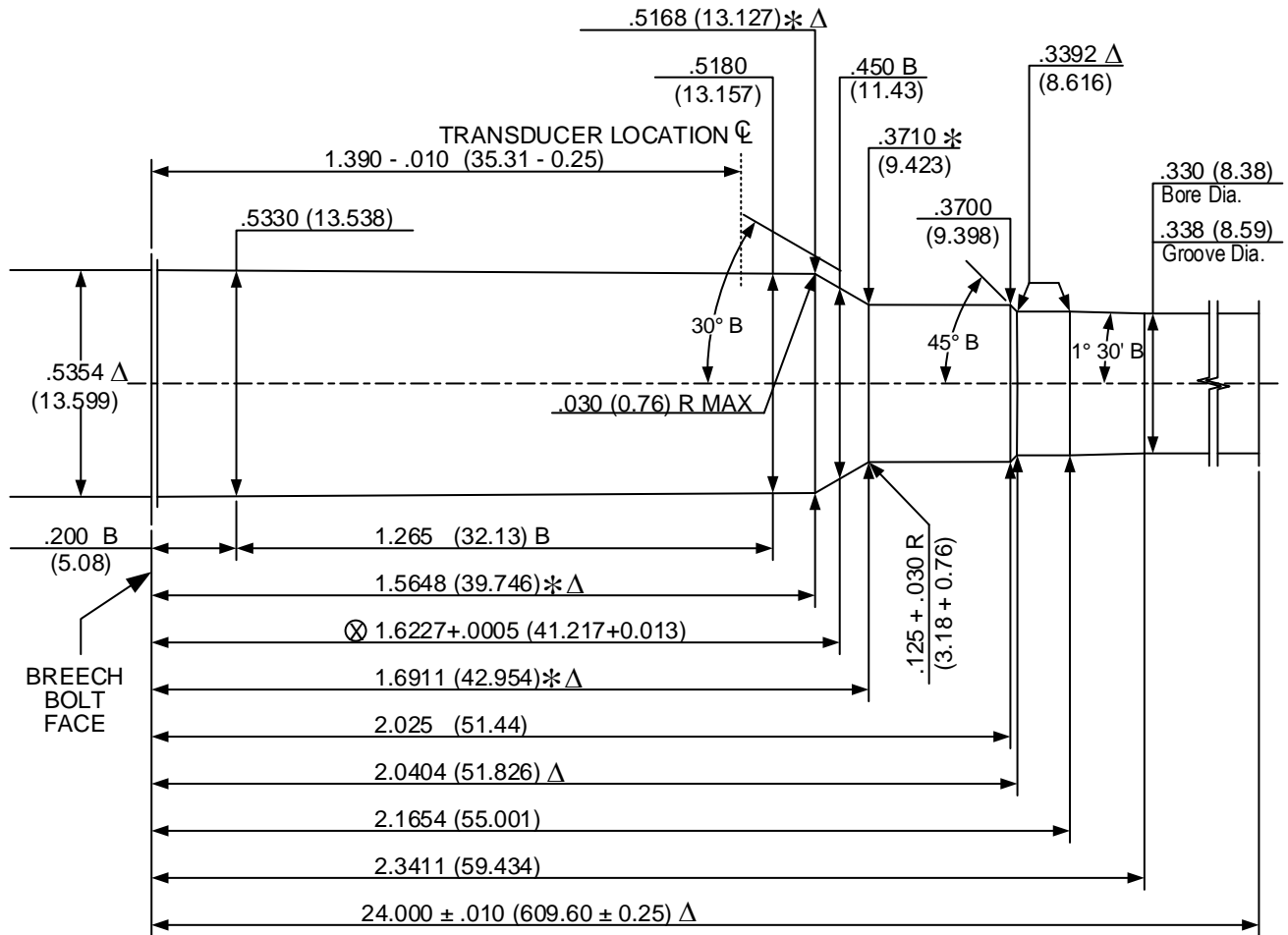

DO NOT SCALE FROM DRAWING

NUMBER OF GROOVES: 6
 WIDTH OF GROOVES: .110 + .002 (2.79 + 0.051)
 TWIST RATE: 10.00 (254.0) R.H.
 DIAMETER OF PISTON HOLE: Crusher pressures not established
 TRANSDUCER DIAMETER: .250 (6.35)

LAND AND GROOVE DIMENSIONS TO BE
 WITHIN TOLERANCES THROUGHOUT
 LENGTH OF BARREL.

UNLESS OTHERWISE NOTED,
 ALL DIAMETERS +.0005 (0.013)
 LENGTH TOLERANCE + .005 (0.13)

NOTE:

B = BASIC Δ = REFERENCE DIMENSION ⊗ = HEADSPACE DIMENSION
 * DIMENSIONS ARE TO INTERSECTIONS OF LINES (XX.XX) = MILLIMETERS
 ALL CALCULATIONS APPLY AT MAXIMUM MATERIAL CONDITION (MMC)

338 Winchester Magnum V&P Test Barrel

Issued: 05/20/1980

Revised: 09/21/2005

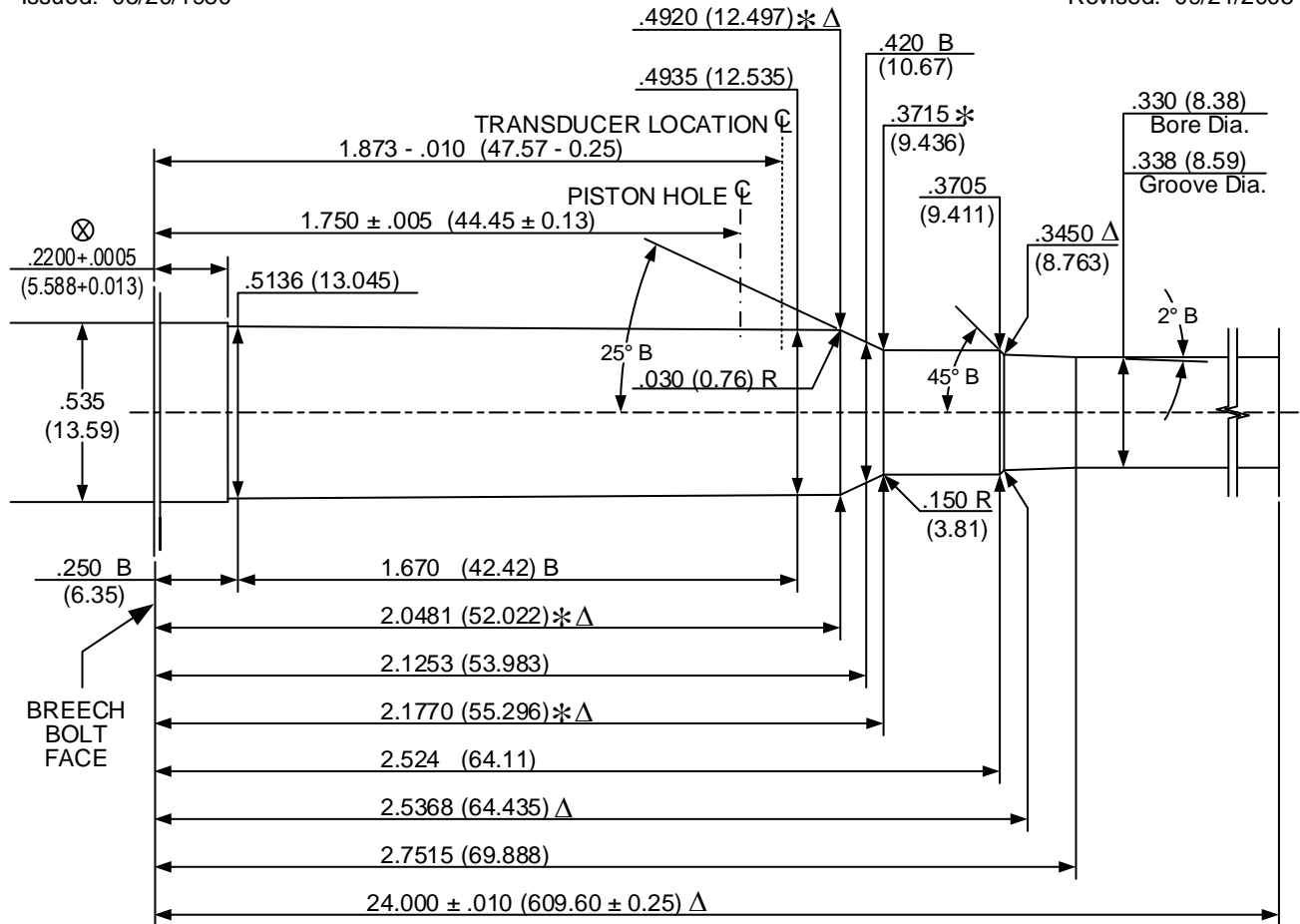

DO NOT SCALE FROM DRAWING

- NUMBER OF GROOVES: 6
- WIDTH OF GROOVES: .110 + .002 (2.79 + 0.05)
- TWIST RATE: 10.00 (254.0) R.H.
- DIAMETER OF PISTON HOLE: .206 (5.23)
- TRANSDUCER DIAMETER: .250 (6.35)

LAND AND GROOVE DIMENSIONS TO BE WITHIN TOLERANCES THROUGHOUT LENGTH OF BARREL.

UNLESS OTHERWISE NOTED, ALL DIAMETERS +.0005 (0.013) LENGTH TOLERANCE + .005 (0.13)

NOTE:

- B = BASIC Δ = REFERENCE DIMENSION ⊗ = HEADSPACE DIMENSION
- * DIMENSIONS ARE TO INTERSECTIONS OF LINES (XX.XX) = MILLIMETERS
- ALL CALCULATIONS APPLY AT MAXIMUM MATERIAL CONDITION (MMC)

340 Weatherby Magnum V&P Test Barrel

Issued: 01/12/1994

Revised: 09/04/2005

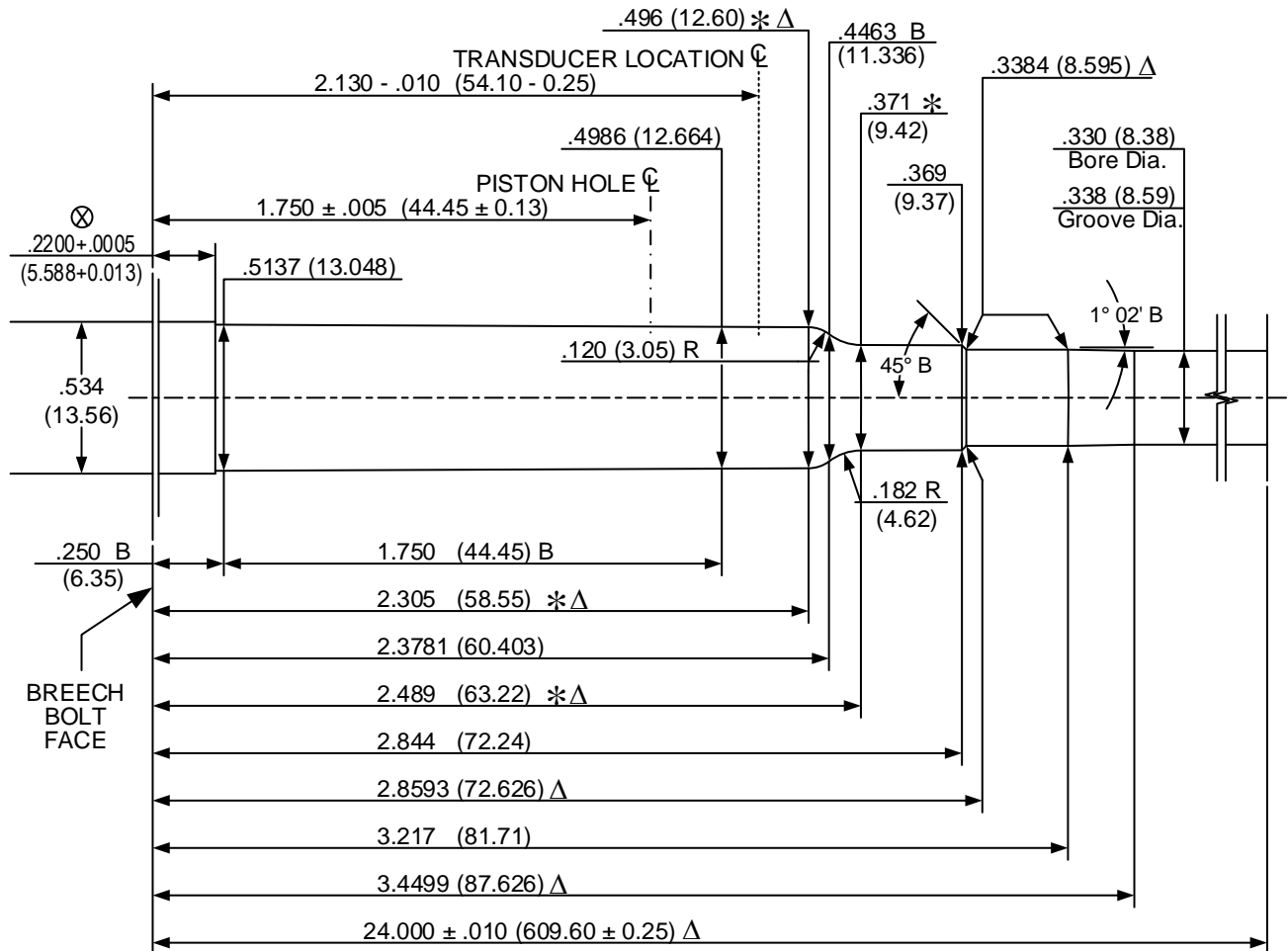

DO NOT SCALE FROM DRAWING

- NUMBER OF GROOVES: 6
- WIDTH OF GROOVES: .126 + .002 (3.20 + 0.05)
- TWIST RATE: 10.00 (254.0) R.H.
- DIAMETER OF PISTON HOLE: .206 (5.23)
- TRANSDUCER DIAMETER: .250 (6.35)

LAND AND GROOVE DIMENSIONS TO BE WITHIN TOLERANCES THROUGHOUT LENGTH OF BARREL.

UNLESS OTHERWISE NOTED, ALL DIAMETERS +.0005 (0.013) LENGTH TOLERANCE + .005 (0.13)

NOTE:

- B = BASIC
- Δ = REFERENCE DIMENSION
- ⊗ = HEADSPACE DIMENSION
- * DIMENSIONS ARE TO INTERSECTIONS OF LINES
- (XX.XX) = MILLIMETERS
- ALL CALCULATIONS APPLY AT MAXIMUM MATERIAL CONDITION (MMC)

348 Winchester V&P Test Barrel

Issued: 05/20/1980

Revised: 09/24/2005

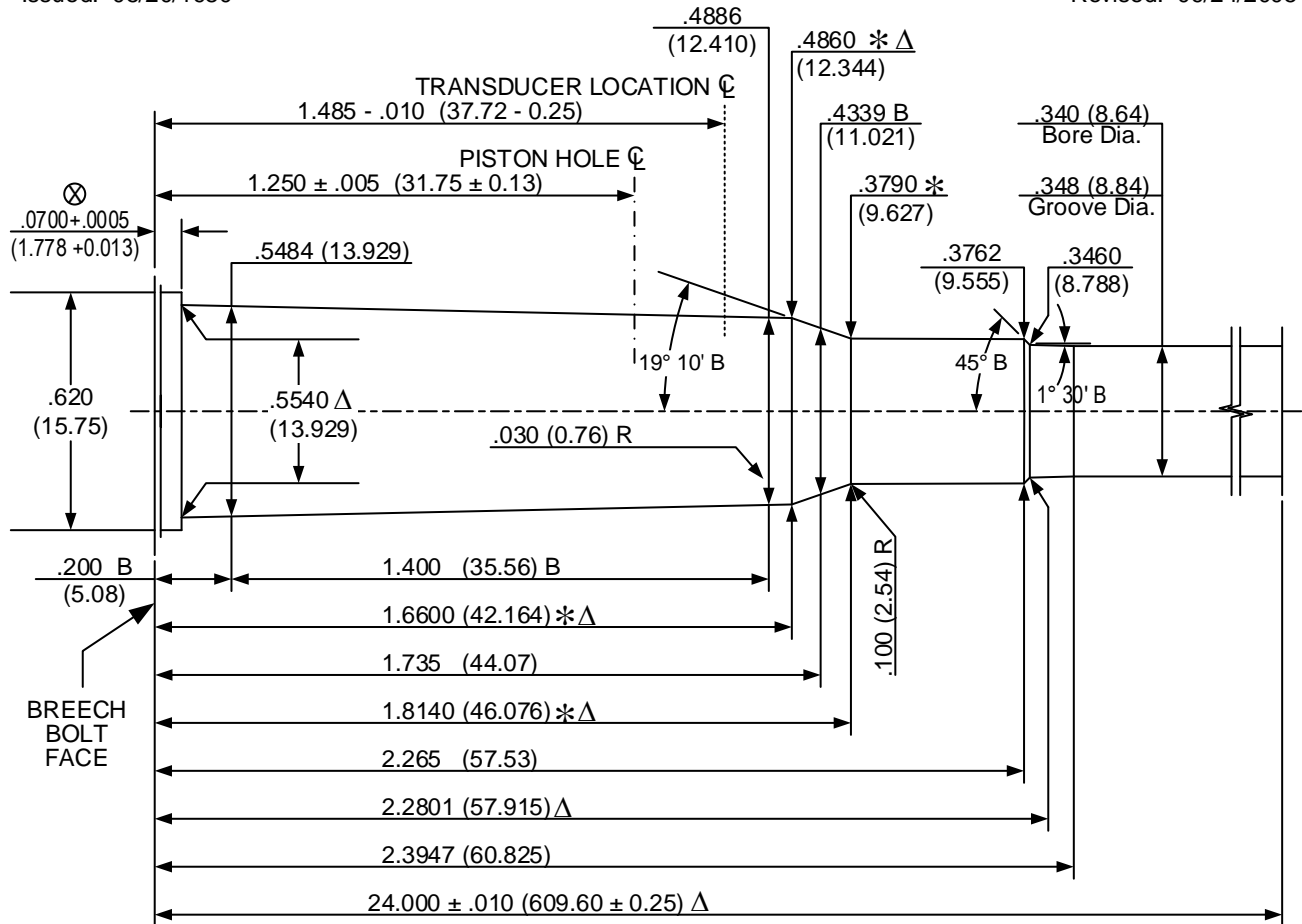

DO NOT SCALE FROM DRAWING

- NUMBER OF GROOVES: 6
- WIDTH OF GROOVES: .120 + .002 (3.05 + 0.05)
- TWIST RATE: 12.00 (304.8) R.H.
- DIAMETER OF PISTON HOLE: .206 (5.23)
- TRANSDUCER DIAMETER: .250 (6.53)

LAND AND GROOVE DIMENSIONS TO BE WITHIN TOLERANCES THROUGHOUT LENGTH OF BARREL.

UNLESS OTHERWISE NOTED, ALL DIAMETERS +.0005 (0.013) LENGTH TOLERANCE + .005 (0.13)

NOTE:

- B = BASIC
- Δ = REFERENCE DIMENSION
- ⊗ = HEADSPACE DIMENSION
- * DIMENSIONS ARE TO INTERSECTIONS OF LINES
- (XX.XX) = MILLIMETERS
- ALL CALCULATIONS APPLY AT MAXIMUM MATERIAL CONDITION (MMC)

35 Nosler V&P Test Barrel

Issued: 01/19/2015

Revised: - / - / - - -

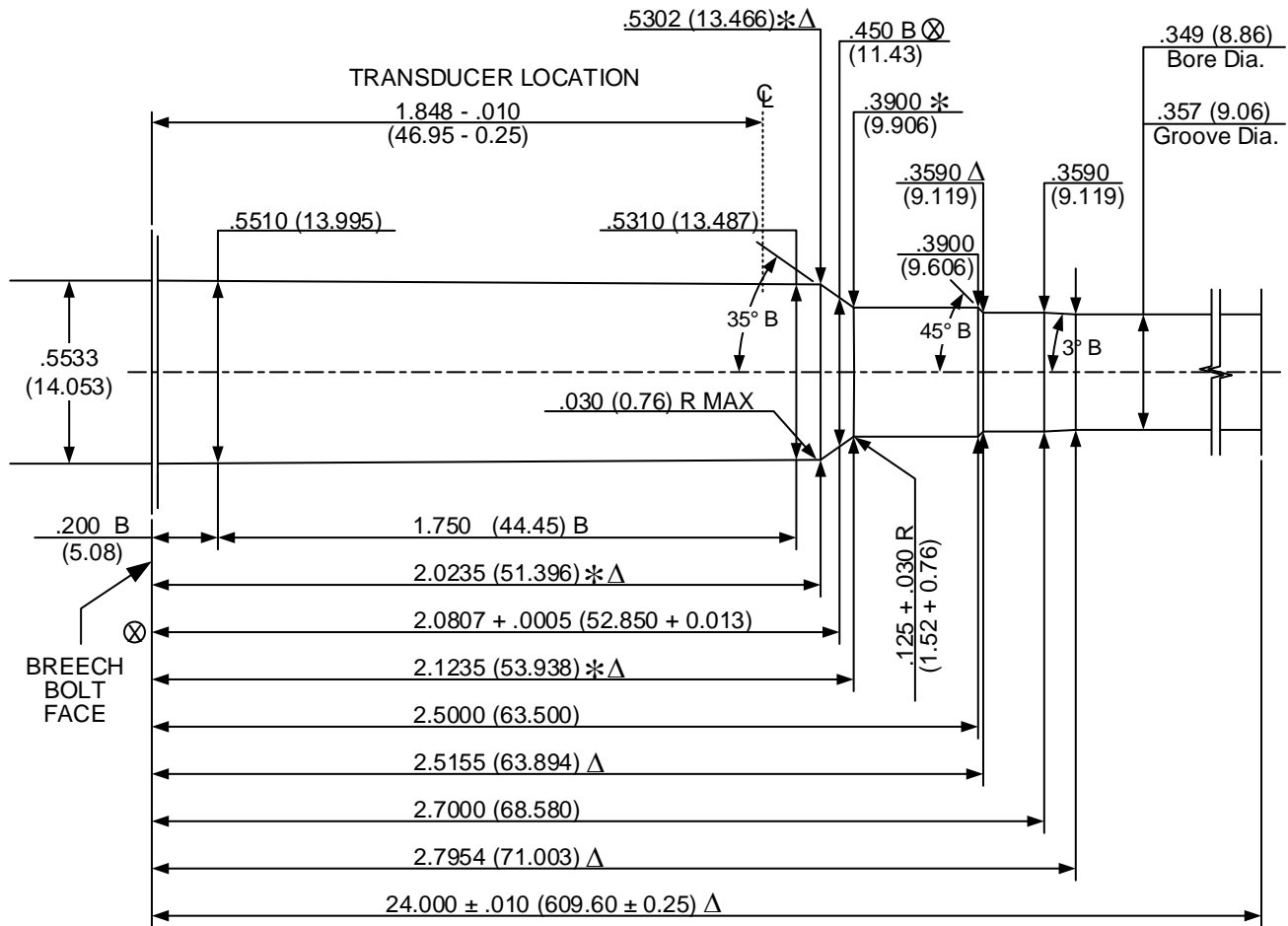

DO NOT SCALE FROM DRAWING

- NUMBER OF GROOVES: 6
- WIDTH OF GROOVES: .130 + .002 (2.79 + 0.05)
- TWIST RATE: 12.00 (304.8) R.H.
- DIAMETER OF PISTON HOLE: Crusher pressures not established.
- TRANSDUCER DIAMETER: .250 (6.35)

LAND AND GROOVE DIMENSIONS TO BE WITHIN TOLERANCES THROUGHOUT LENGTH OF BARREL.

UNLESS OTHERWISE NOTED, ALL DIAMETERS +.0005 (0.013) LENGTH TOLERANCE + .005 (0.13)

NOTE:

- B = BASIC
- Δ = REFERENCE DIMENSION
- ⊗ = HEADSPACE DIMENSION
- * DIMENSIONS ARE TO INTERSECTIONS OF LINES
- (XX.XX) = MILLIMETERS
- ALL CALCULATIONS APPLY AT MAXIMUM MATERIAL CONDITION (MMC)

35 Remington V&P Test Barrel

Issued: 06/04/1998

Revised: 10/07/2005

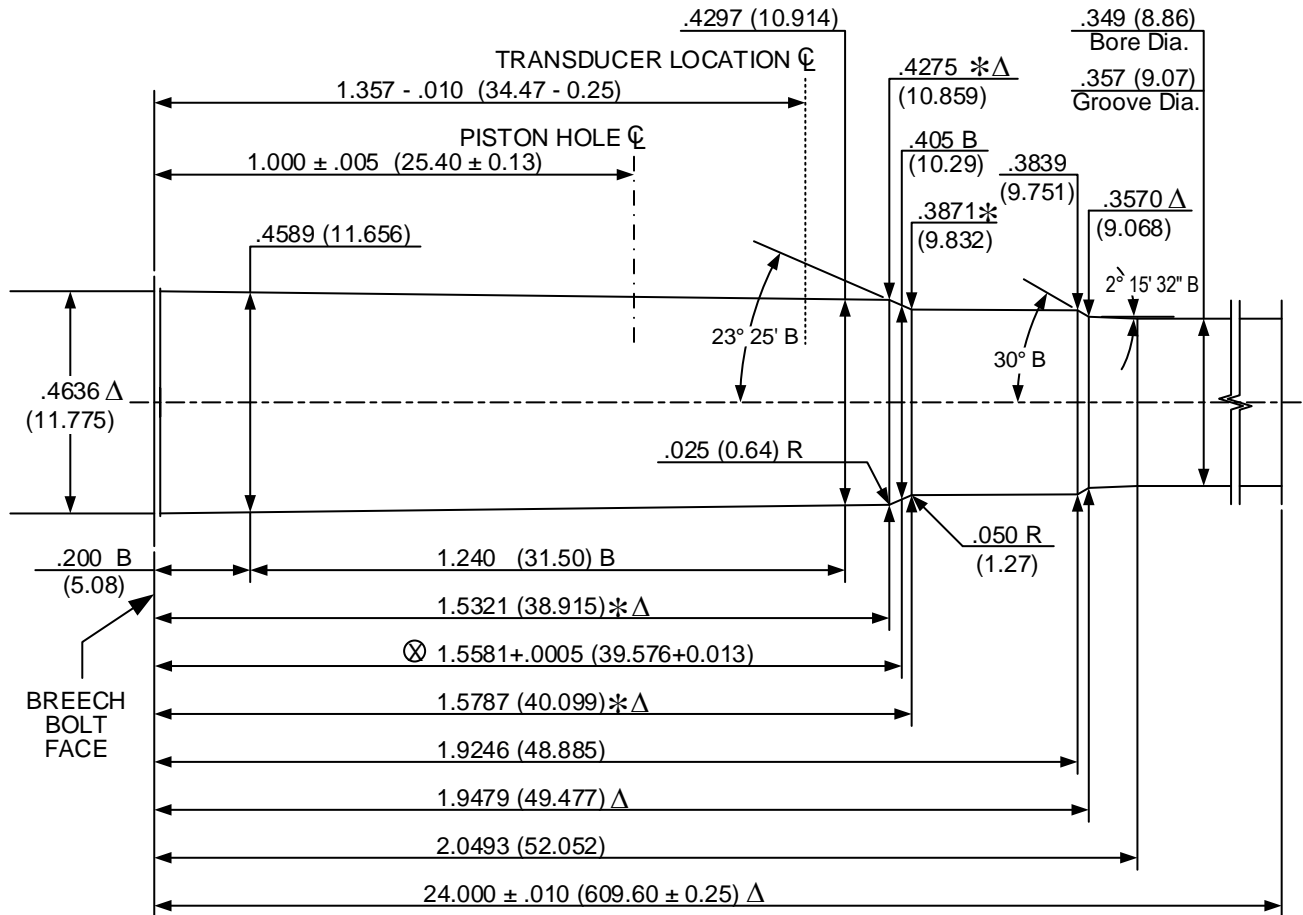

DO NOT SCALE FROM DRAWING

- NUMBER OF GROOVES: 7
- WIDTH OF GROOVES: .115 + .002 (2.92 + 0.05)
- TWIST RATE: 16.00 (406.4) R.H.
- DIAMETER OF PISTON HOLE: .206 (5.23)
- TRANSDUCER DIAMETER: .250 (6.35)

LAND AND GROOVE DIMENSIONS TO BE WITHIN TOLERANCES THROUGHOUT LENGTH OF BARREL.

UNLESS OTHERWISE NOTED, ALL DIAMETERS +.0005 (0.013) LENGTH TOLERANCE + .005 (0.13)

NOTE:

- B = BASIC Δ = REFERENCE DIMENSION ⊗ = HEADSPACE DIMENSION
- * DIMENSIONS ARE TO INTERSECTIONS OF LINES (XX.XX) = MILLIMETERS
- ALL CALCULATIONS APPLY AT MAXIMUM MATERIAL CONDITION (MMC)

35 Whelen V&P Test Barrel

Issued: 06/04/1998

Revised: 09/24/2005

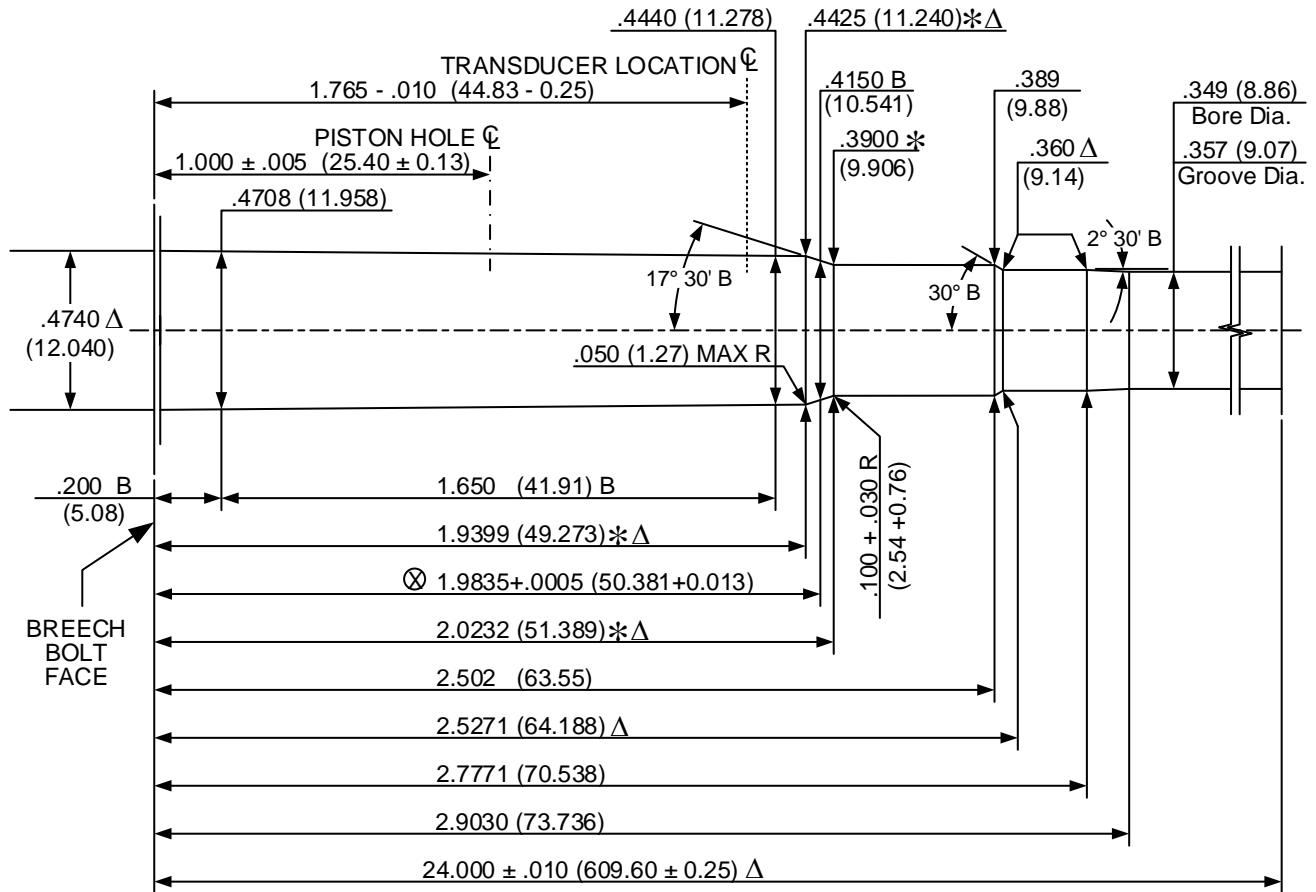

DO NOT SCALE FROM DRAWING

- NUMBER OF GROOVES: 6
- WIDTH OF GROOVES: .130 + .002 (3.30 + 0.05)
- TWIST RATE: 16.00 (406.4) R.H.
- DIAMETER OF PISTON HOLE: .206 (5.23)
- TRANSDUCER DIAMETER: .250 (6.35)

LAND AND GROOVE DIMENSIONS TO BE WITHIN TOLERANCES THROUGHOUT LENGTH OF BARREL.

UNLESS OTHERWISE NOTED, ALL DIAMETERS +.0005 (0.013) LENGTH TOLERANCE + .005 (0.13)

NOTE:

- B = BASIC
- Δ = REFERENCE DIMENSION
- ⊗ = HEADSPACE DIMENSION
- * DIMENSIONS ARE TO INTERSECTIONS OF LINES
- (XX.XX) = MILLIMETERS
- ALL CALCULATIONS APPLY AT MAXIMUM MATERIAL CONDITION (MMC)

350 Remington Magnum V&P Test Barrel

Issued: 05/20/1980

Revised: 09/25/2005

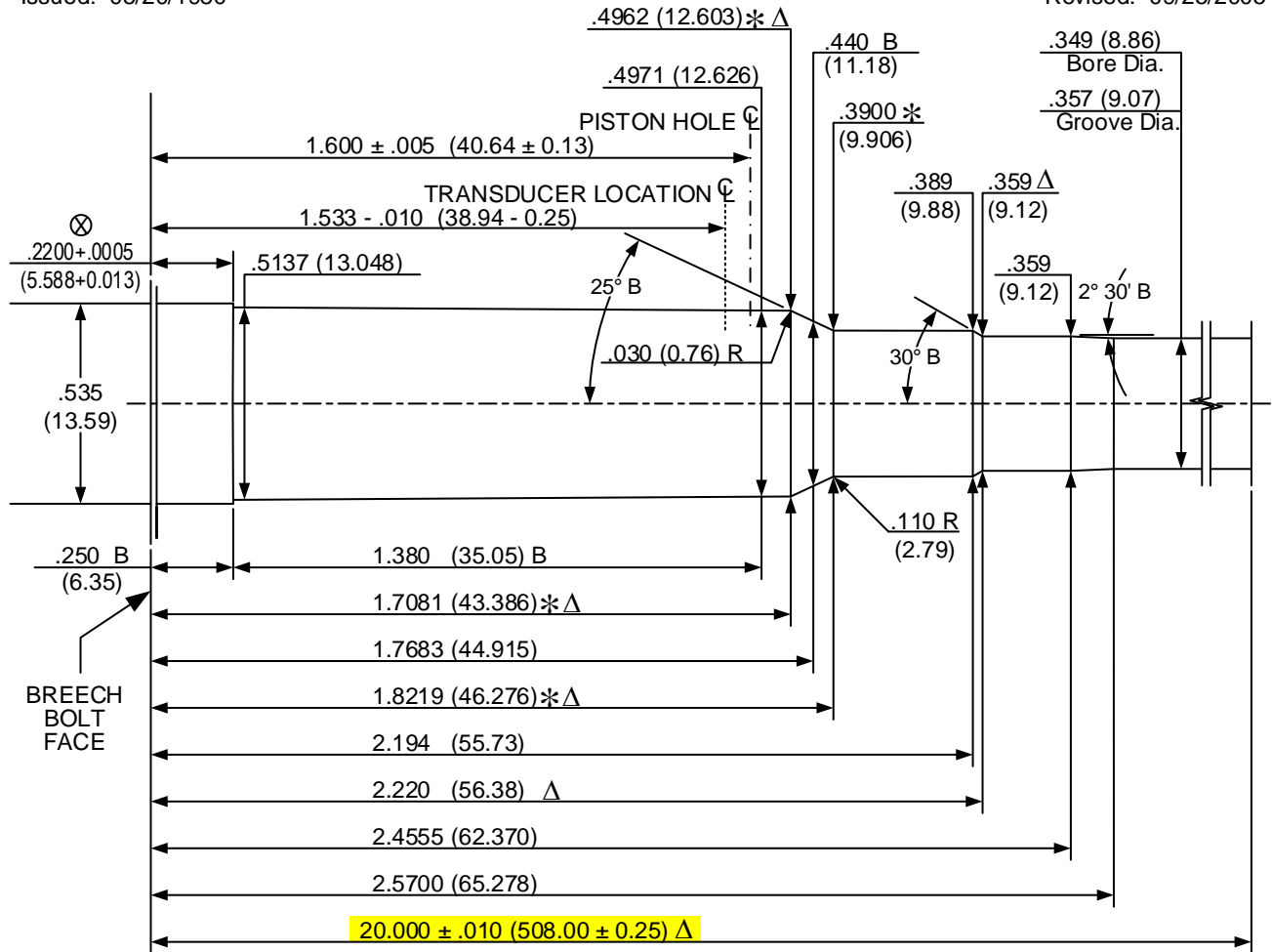

DO NOT SCALE FROM DRAWING

- NUMBER OF GROOVES: 6
- WIDTH OF GROOVES: .130 + .002 (3.30 + 0.05)
- TWIST RATE: 16.00 (406.4) R.H.
- DIAMETER OF PISTON HOLE: .206 (5.23)
- TRANSDUCER DIAMETER: .250 (6.35)

LAND AND GROOVE DIMENSIONS TO BE WITHIN TOLERANCES THROUGHOUT LENGTH OF BARREL.

UNLESS OTHERWISE NOTED, ALL DIAMETERS +.0005 (0.013) LENGTH TOLERANCE + .005 (0.13)

NOTE:

- B = BASIC Δ = REFERENCE DIMENSION ⊗ = HEADSPACE DIMENSION
- * DIMENSIONS ARE TO INTERSECTIONS OF LINES (XX.XX) = MILLIMETERS
- ALL CALCULATIONS APPLY AT MAXIMUM MATERIAL CONDITION (MMC)

356 Winchester V&P Test Barrel

Issued: 11/08/1983

Revised: 10/07/2005

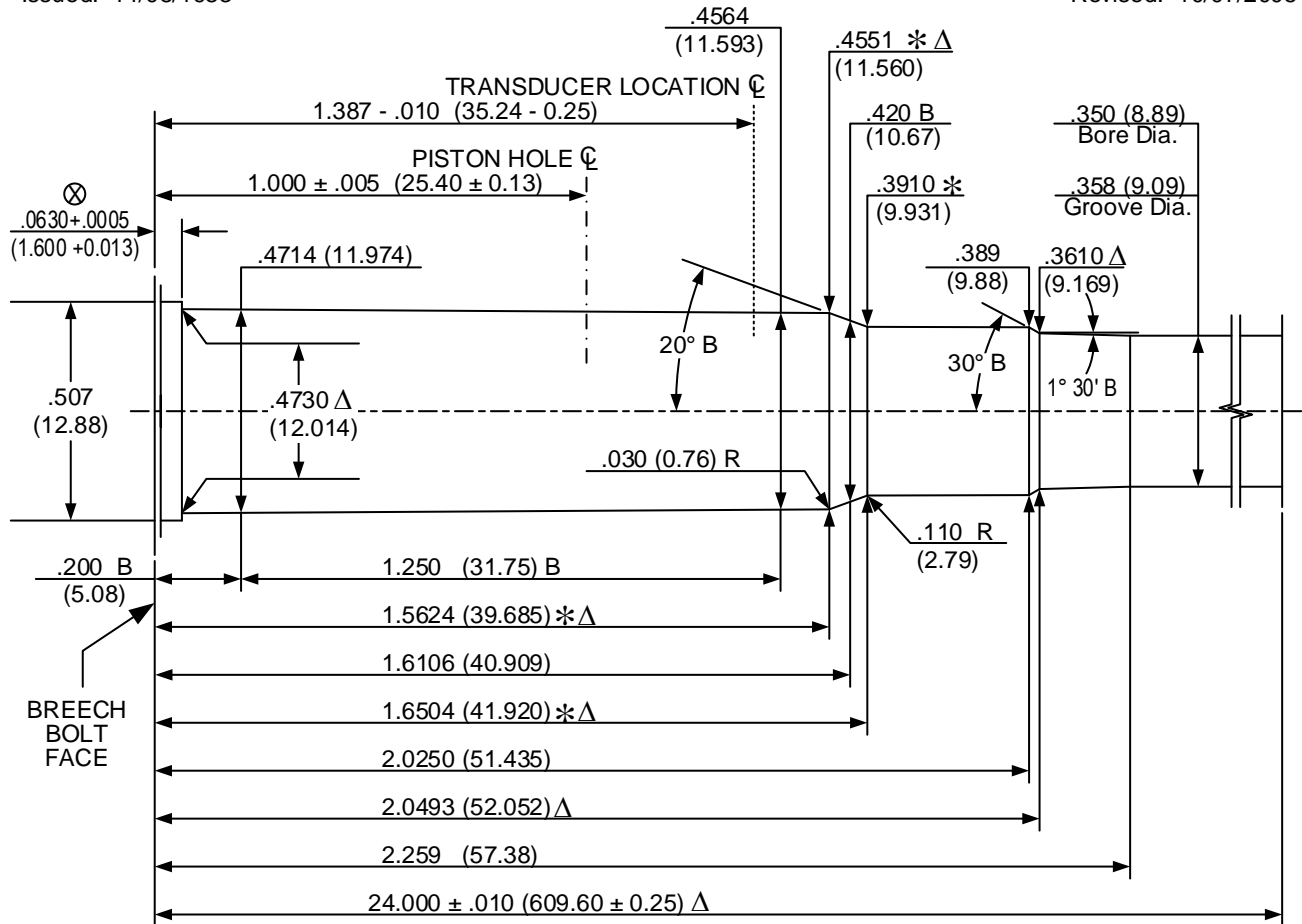

DO NOT SCALE FROM DRAWING

- NUMBER OF GROOVES: 6
- WIDTH OF GROOVES: .1099 + .002 (2.791 + 0.05)
- TWIST RATE: 12.00 (304.8) R.H.
- DIAMETER OF PISTON HOLE: .206 (5.23)
- TRANSDUCER DIAMETER: .250 (6.53)

LAND AND GROOVE DIMENSIONS TO BE WITHIN TOLERANCES THROUGHOUT LENGTH OF BARREL.

UNLESS OTHERWISE NOTED, ALL DIAMETERS +.0005 (0.013) LENGTH TOLERANCE + .005 (0.13)

NOTE:

B = BASIC Δ = REFERENCE DIMENSION ⊗ = HEADSPACE DIMENSION
 * DIMENSIONS ARE TO INTERSECTIONS OF LINES (XX.XX) = MILLIMETERS
 ALL CALCULATIONS APPLY AT MAXIMUM MATERIAL CONDITION (MMC)

358 Winchester V&P Test Barrel

Issued: 06/04/1998

Revised: 10/07/2005

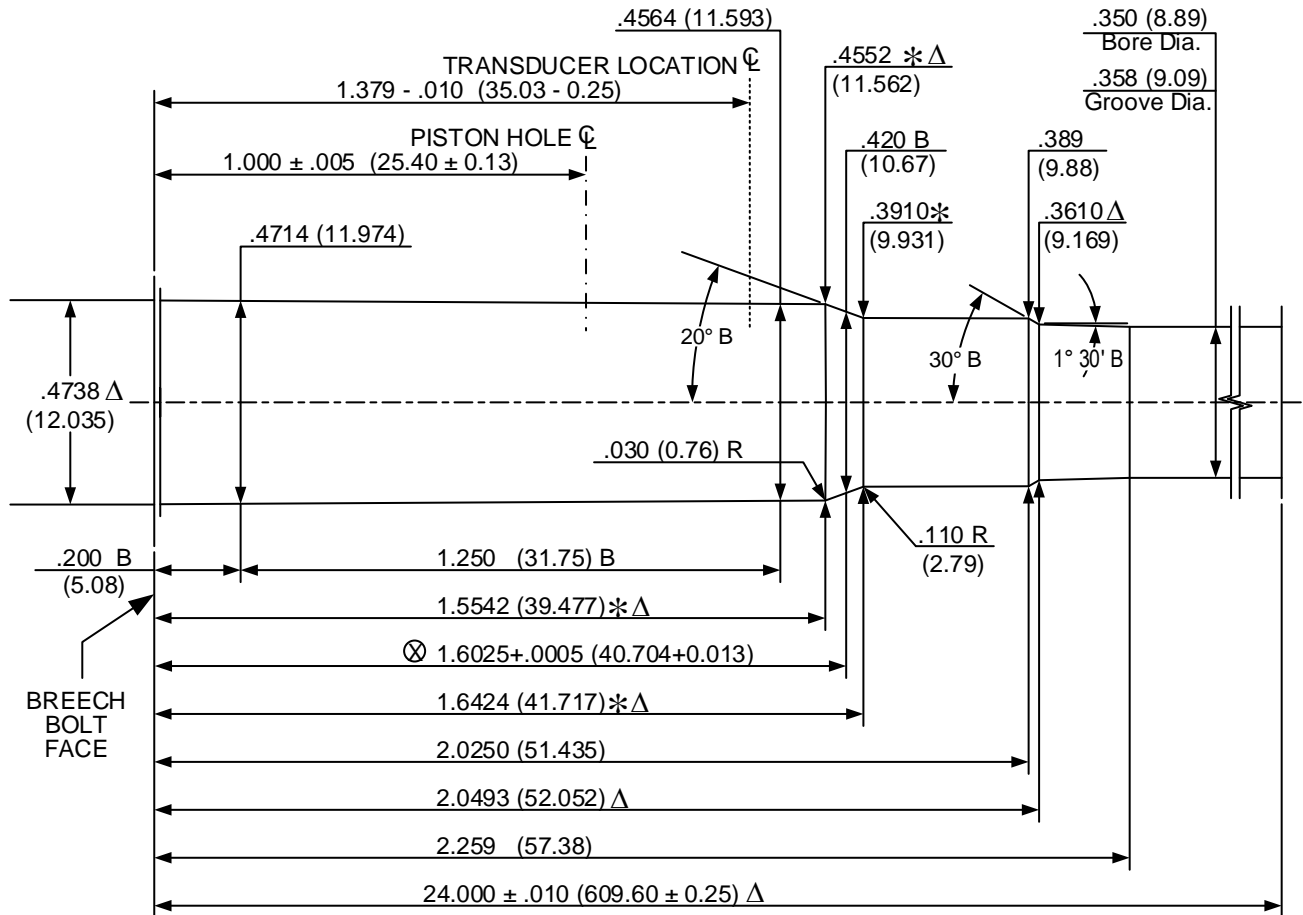

DO NOT SCALE FROM DRAWING

- NUMBER OF GROOVES: 6
- WIDTH OF GROOVES: .1099 + .0020 (2.791 + 0.051)
- TWIST RATE: 12.00 (304.8) R.H.
- DIAMETER OF PISTON HOLE: .206 (5.23)
- TRANSDUCER DIAMETER: .250 (6.35)

LAND AND GROOVE DIMENSIONS TO BE WITHIN TOLERANCES THROUGHOUT LENGTH OF BARREL.

UNLESS OTHERWISE NOTED, ALL DIAMETERS +.0005 (0.013) LENGTH TOLERANCE + .005 (0.13)

NOTE:

- B = BASIC
- Δ = REFERENCE DIMENSION
- ⊗ = HEADSPACE DIMENSION
- * DIMENSIONS ARE TO INTERSECTIONS OF LINES
- (XX.XX) = MILLIMETERS
- ALL CALCULATIONS APPLY AT MAXIMUM MATERIAL CONDITION (MMC)

36 Nosler V&P Test Barrel

Issued: 01/19/2015

Revised: - - / - - / - - - -

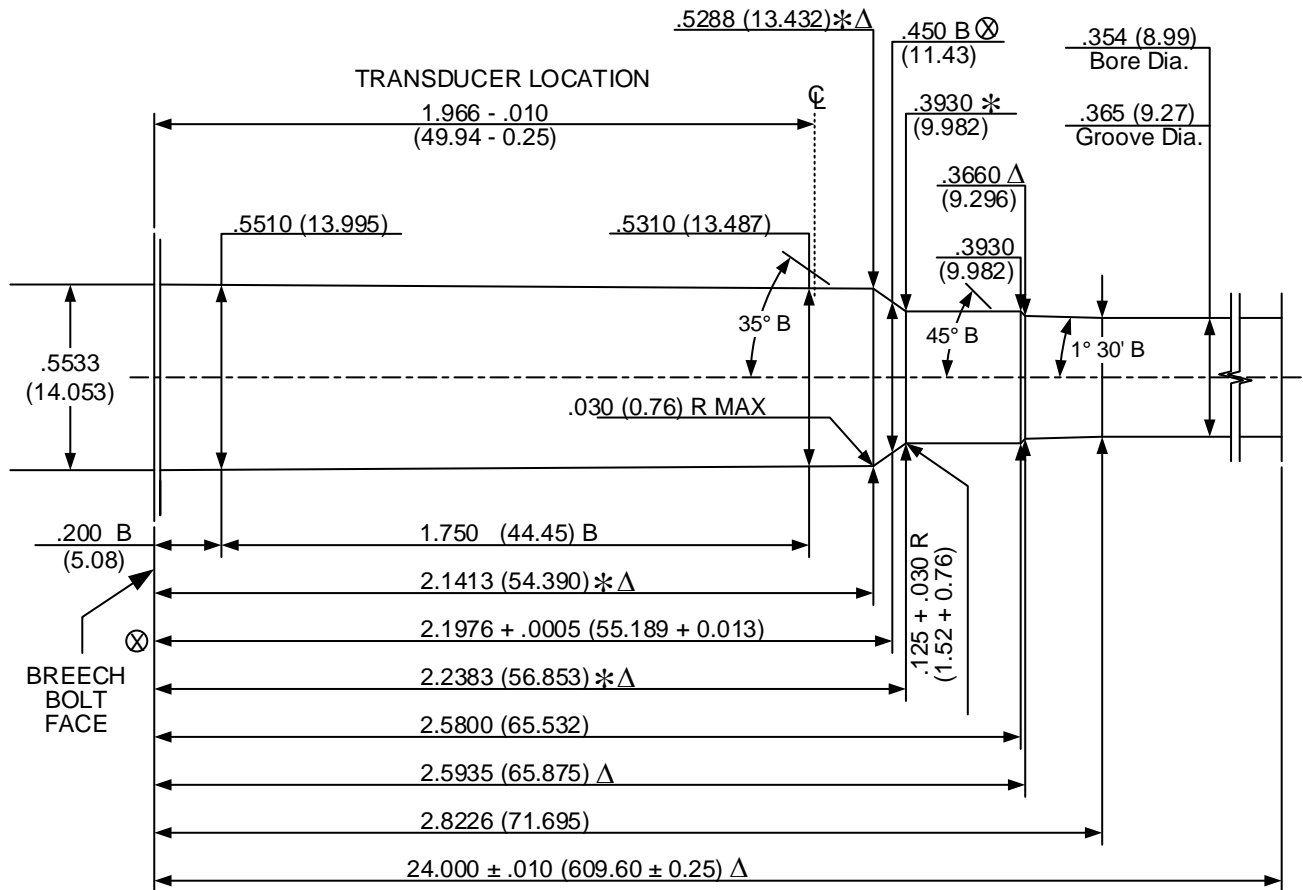

DO NOT SCALE FROM DRAWING

NUMBER OF GROOVES: 4
 WIDTH OF GROOVES: .181 + .002 (4.60 + 0.05)
 TWIST RATE: 14.00 (355.6) R.H.
 DIAMETER OF PISTON HOLE: Crusher pressures not established.
 TRANSDUCER DIAMETER: .250 (6.35)

LAND AND GROOVE DIMENSIONS TO BE
 WITHIN TOLERANCES THROUGHOUT
 LENGTH OF BARREL.

UNLESS OTHERWISE NOTED,
 ALL DIAMETERS +.0005 (0.013)
 LENGTH TOLERANCE + .005 (0.13)

NOTE:

B = BASIC Δ = REFERENCE DIMENSION ⊗ = HEADSPACE DIMENSION
 * DIMENSIONS ARE TO INTERSECTIONS OF LINES (XX.XX) = MILLIMETERS
 ALL CALCULATIONS APPLY AT MAXIMUM MATERIAL CONDITION (MMC)

370 Sako Magnum V&P Test Barrel

Issued: 01/18/2011

Revised: - - / - - / - - - -

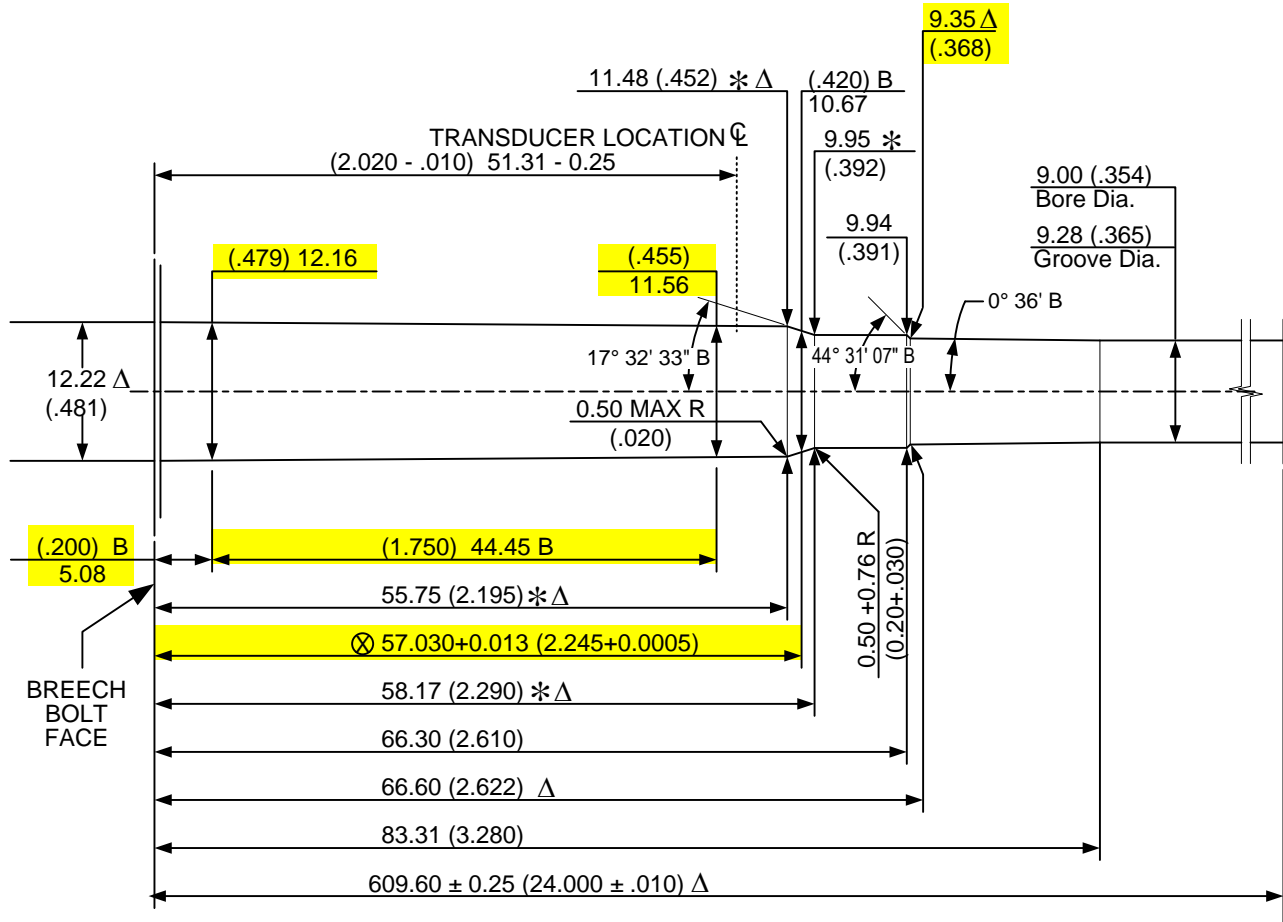

METRIC (9.3x66 SAKO)

DO NOT SCALE FROM DRAWING

HIGHLIGHTED DIMENSIONS HAVE NO CORRESPONDING C.I.P. ANALOG. THE ENGLISH UNITS FOR THESE ARE THE ORIGINAL VALUES; METRIC VALUES ARE CALCULATED AND ROUNDED.

NUMBER OF GROOVES: 6
 WIDTH OF GROOVES: 3.14 + 0.05 (.124 + .002)
 TWIST RATE: 360.00 (14.173) R.H.
 DIAMETER OF PISTON HOLE: Crusher pressures not established
 TRANSDUCER DIAMETER: .250 (6.35)

LAND AND GROOVE DIMENSIONS TO BE WITHIN TOLERANCES THROUGHOUT LENGTH OF BARREL.

UNLESS OTHERWISE NOTED, ALL DIAMETERS +0.013 (.0005) LENGTH TOLERANCE +0.13 (.005)

NOTE:

B = BASIC Δ = REFERENCE DIMENSION ⊗ = HEADSPACE DIMENSION
 * DIMENSIONS ARE TO INTERSECTIONS OF LINES (XX.XX) = INCHES
 ALL CALCULATIONS APPLY AT MAXIMUM MATERIAL CONDITION (MMC)

375 Holland & Holland Magnum V&P Test Barrel

Issued: 05/20/1980

Revised: 11/14/2005

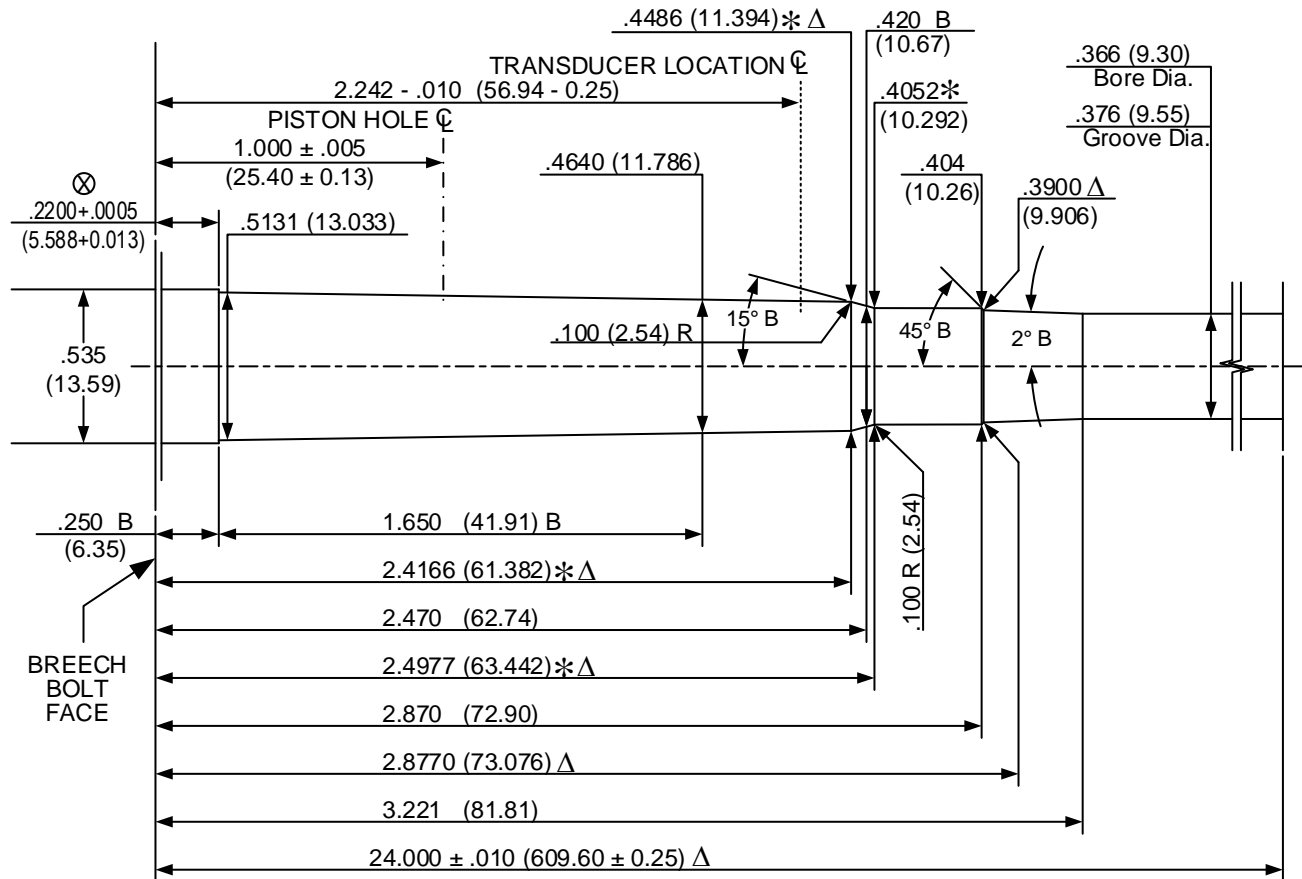

DO NOT SCALE FROM DRAWING

- NUMBER OF GROOVES: 6
- WIDTH OF GROOVES: .115 + .002 (2.92 + 0.05)
- TWIST RATE: 12.00 (304.8) R.H.
- DIAMETER OF PISTON HOLE: .206 (5.23)
- TRANSDUCER DIAMETER: .250 (6.35)

LAND AND GROOVE DIMENSIONS TO BE WITHIN TOLERANCES THROUGHOUT LENGTH OF BARREL.

UNLESS OTHERWISE NOTED, ALL DIAMETERS +.0005 (0.013) LENGTH TOLERANCE + .005 (0.13)

NOTE:

- B = BASIC Δ = REFERENCE DIMENSION ⊗ = HEADSPACE DIMENSION
- * DIMENSIONS ARE TO INTERSECTIONS OF LINES (XX.XX) = MILLIMETERS
- ALL CALCULATIONS APPLY AT MAXIMUM MATERIAL CONDITION (MMC)

375 Remington Ultra Magnum V&P Test Barrel

Issued: 01/10/2001

Revised: 11/28/2005

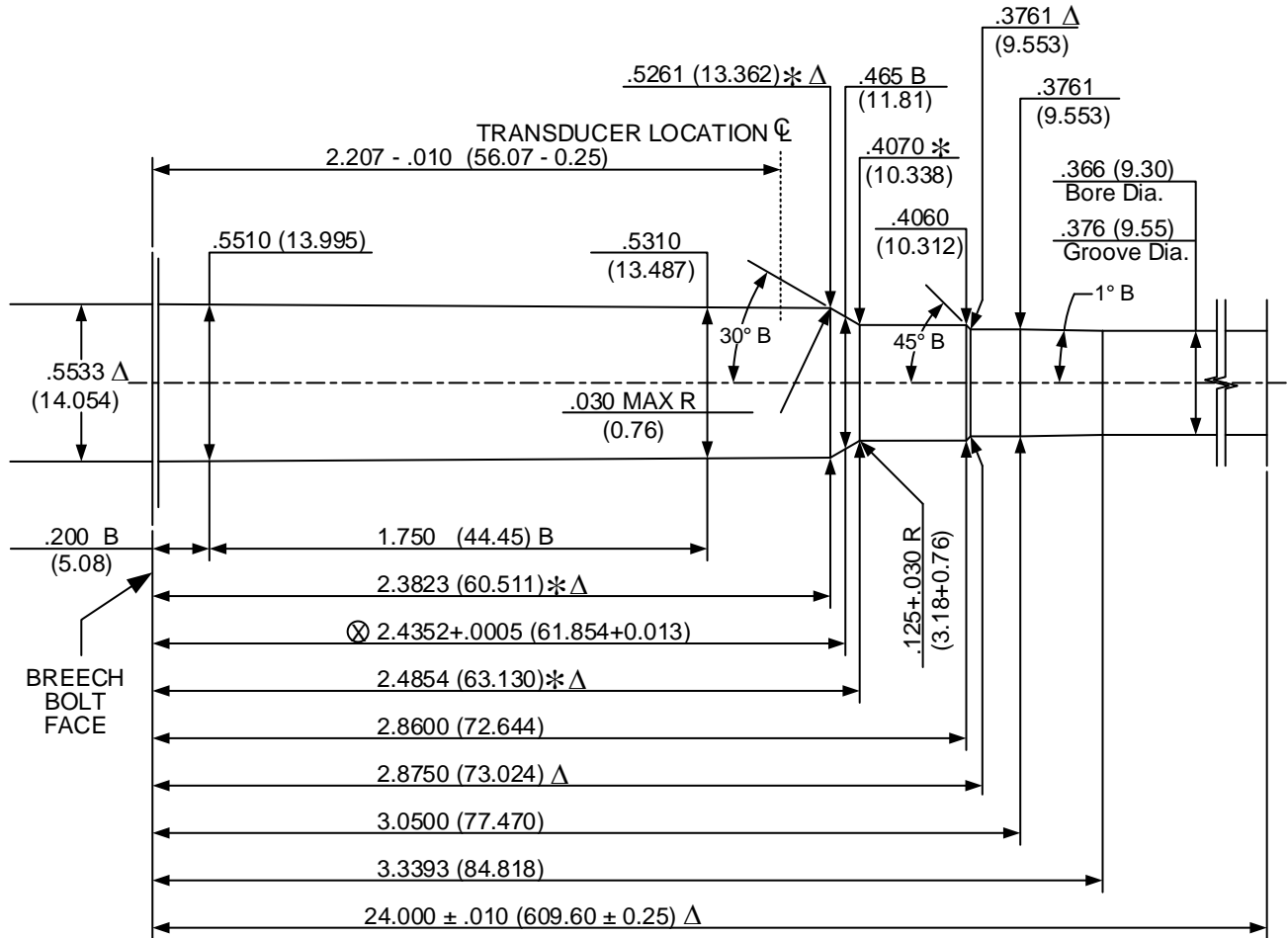

DO NOT SCALE FROM DRAWING

- NUMBER OF GROOVES: 6
- WIDTH OF GROOVES: .115 + .002 (2.92 + 0.05)
- TWIST RATE: 12.00 (304.8) R.H.
- DIAMETER OF PISTON HOLE: Crusher pressures not established
- TRANSDUCER DIAMETER: .250 (6.35)

LAND AND GROOVE DIMENSIONS TO BE WITHIN TOLERANCES THROUGHOUT LENGTH OF BARREL.

UNLESS OTHERWISE NOTED, ALL DIAMETERS +.0005 (0.013) LENGTH TOLERANCE + .005 (0.13)

NOTE:

- B = BASIC
- Δ = REFERENCE DIMENSION
- ⊗ = HEADSPACE DIMENSION
- * DIMENSIONS ARE TO INTERSECTIONS OF LINES
- (XX.XX) = MILLIMETERS
- ALL CALCULATIONS APPLY AT MAXIMUM MATERIAL CONDITION (MMC)

375 Ruger V&P Test Barrel

Issued: 01/06/2009

Revised: 12/21/2016

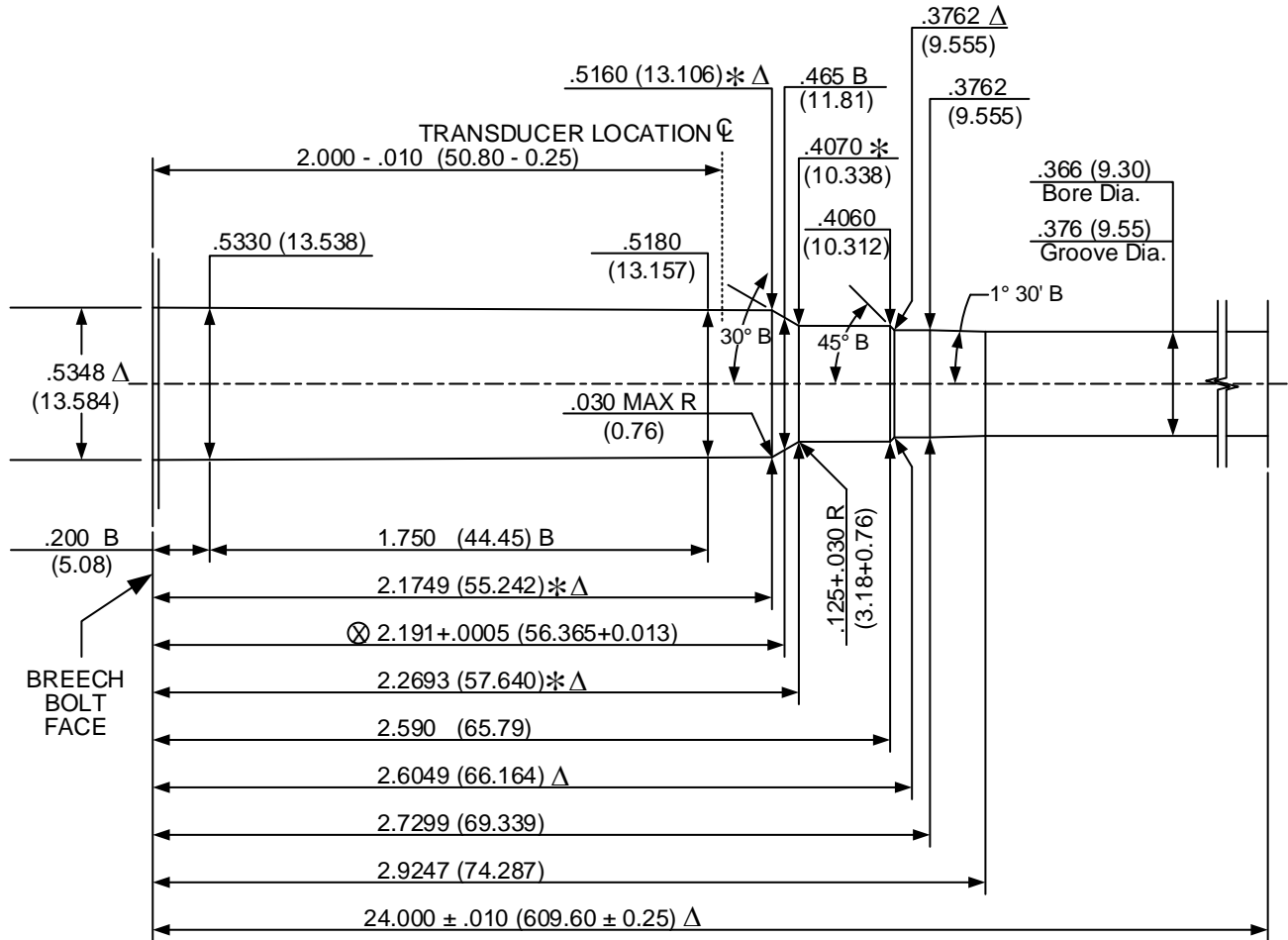

DO NOT SCALE FROM DRAWING

- NUMBER OF GROOVES: 6
- WIDTH OF GROOVES: .115 + .002 (2.92 + 0.05)
- TWIST RATE: 12.00 (304.8) R.H.
- DIAMETER OF PISTON HOLE: Crusher pressures not established
- TRANSDUCER DIAMETER: .250 (6.35)

LAND AND GROOVE DIMENSIONS TO BE WITHIN TOLERANCES THROUGHOUT LENGTH OF BARREL.

UNLESS OTHERWISE NOTED, ALL DIAMETERS +.0005 (0.013) LENGTH TOLERANCE + .005 (0.13)

NOTE:

- B = BASIC Δ = REFERENCE DIMENSION ⊗ = HEADSPACE DIMENSION
- * DIMENSIONS ARE TO INTERSECTIONS OF LINES (XX.XX) = MILLIMETERS
- ALL CALCULATIONS APPLY AT MAXIMUM MATERIAL CONDITION (MMC)

375 Winchester V&P Test Barrel

Issued: 05/20/1980

Revised: 11/14/2005

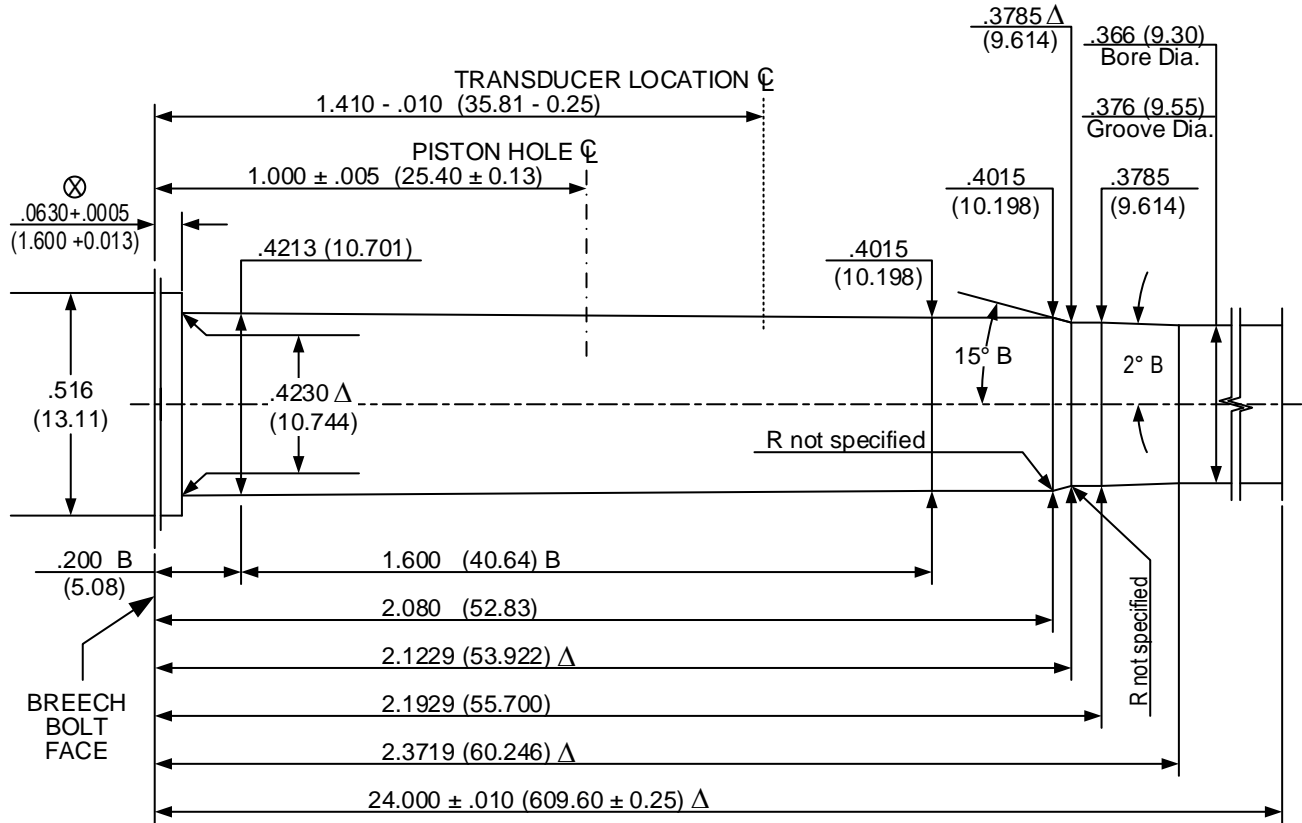

DO NOT SCALE FROM DRAWING

- NUMBER OF GROOVES: 6
- WIDTH OF GROOVES: .115 + .002 (2.92 + 0.05)
- TWIST RATE: 12.00 (304.8) R.H.
- DIAMETER OF PISTON HOLE: .206 (5.23)
- TRANSDUCER DIAMETER: .250 (6.53)

LAND AND GROOVE DIMENSIONS TO BE WITHIN TOLERANCES THROUGHOUT LENGTH OF BARREL.

UNLESS OTHERWISE NOTED, ALL DIAMETERS +.0005 (0.013) LENGTH TOLERANCE + .005 (0.13)

NOTE:

- B = BASIC Δ = REFERENCE DIMENSION ⊗ = HEADSPACE DIMENSION
- * DIMENSIONS ARE TO INTERSECTIONS OF LINES (XX.XX) = MILLIMETERS
- ALL CALCULATIONS APPLY AT MAXIMUM MATERIAL CONDITION (MMC)

376 Steyr V&P Test Barrel

Issued: 06/13/2001

Revised: 11/29/2005

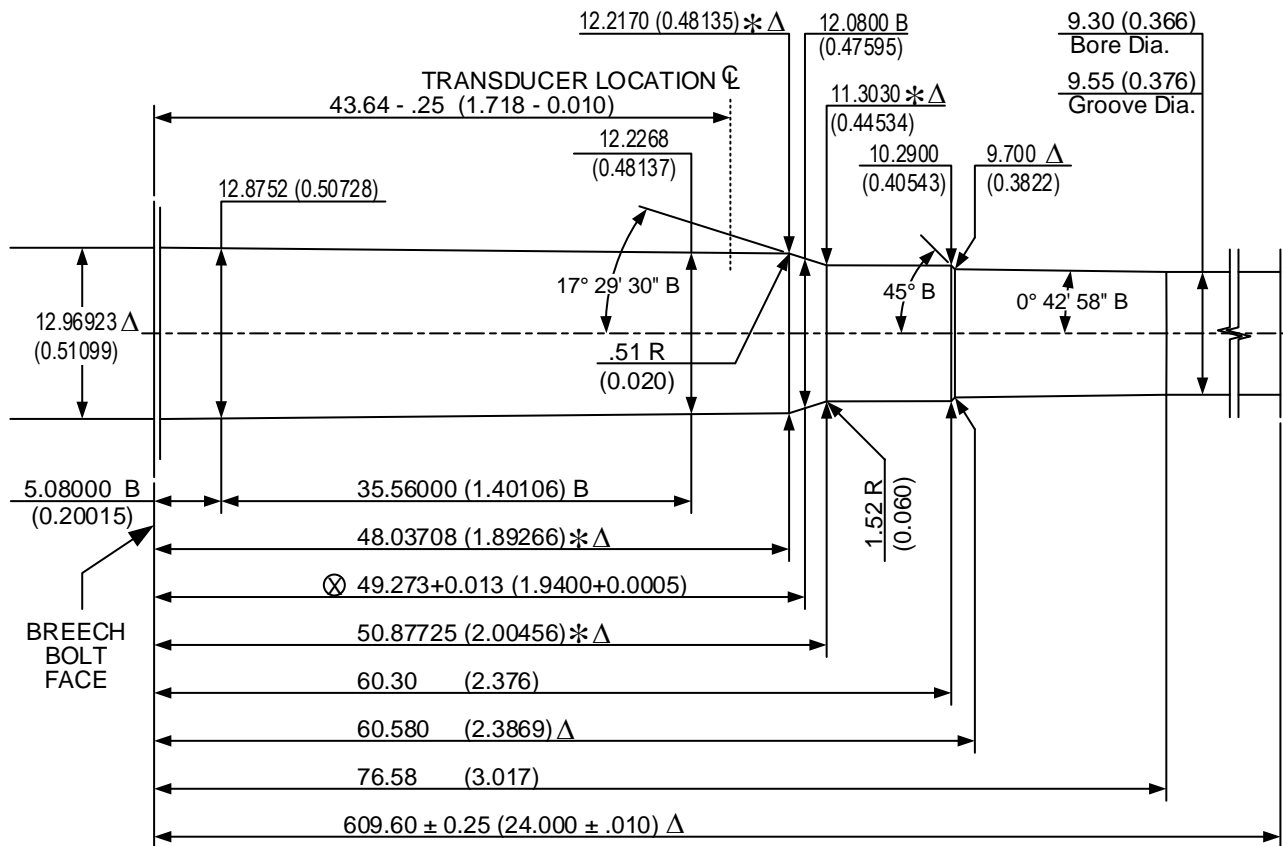

DO NOT SCALE FROM DRAWING

- NUMBER OF GROOVES: 6
- WIDTH OF GROOVES: 2.92 + .05 (0.115 + 0.002)
- TWIST RATE: 304.8 (12.00) R.H.
- DIAMETER OF PISTON HOLE: Crusher pressures not established
- TRANSDUCER DIAMETER: 6.35 (.250)

LAND AND GROOVE DIMENSIONS TO BE WITHIN TOLERANCES THROUGHOUT LENGTH OF BARREL.

UNLESS OTHERWISE NOTED, ALL DIAMETERS +0.013 (0.0005) LENGTH TOLERANCE +0.13 (0.005)

NOTE:

- B = BASIC Δ = REFERENCE DIMENSION ⊗ = HEADSPACE DIMENSION
- * DIMENSIONS ARE TO INTERSECTIONS OF LINES (XX.XX) = INCHES
- ALL CALCULATIONS APPLY AT MAXIMUM MATERIAL CONDITION (MMC)

METRIC METRIC METRIC METRIC METRIC METRIC

38-40 Winchester V&P Test Barrel

Issued: 05/20/1980

Revised: 09/03/2005

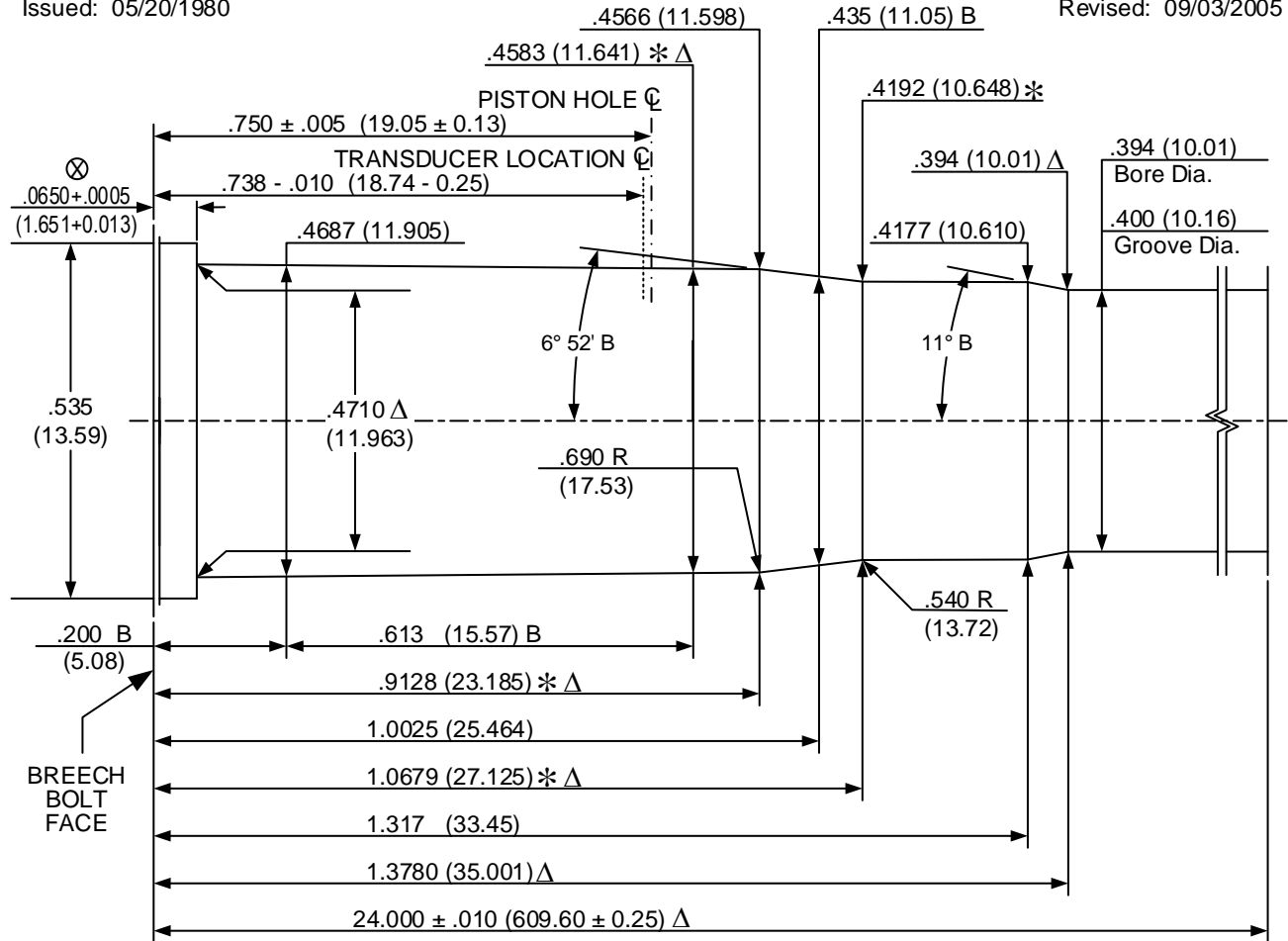

DO NOT SCALE FROM DRAWING

NUMBER OF GROOVES: 6
 WIDTH OF GROOVES: .1237 + .0020 (3.142 + 0.051)
 TWIST RATE: 36.00 (914.4) R.H.
 DIAMETER OF PISTON HOLE: .206 (5.23)
 TRANSDUCER DIAMETER: .250 (6.35)

LAND AND GROOVE DIMENSIONS TO BE
 WITHIN TOLERANCES THROUGHOUT
 LENGTH OF BARREL.

UNLESS OTHERWISE NOTED,
 ALL DIAMETERS +.0005 (0.013)
 LENGTH TOLERANCE + .005 (0.13)

NOTE:

B = BASIC Δ = REFERENCE DIMENSION ⊗ = HEADSPACE DIMENSION
 * DIMENSIONS ARE TO INTERSECTIONS OF LINES (XX.XX) = MILLIMETERS
 ALL CALCULATIONS APPLY AT MAXIMUM MATERIAL CONDITION (MMC)

38-55 Winchester V&P Test Barrel

Issued: 05/20/1980

Revised: 11/14/2005

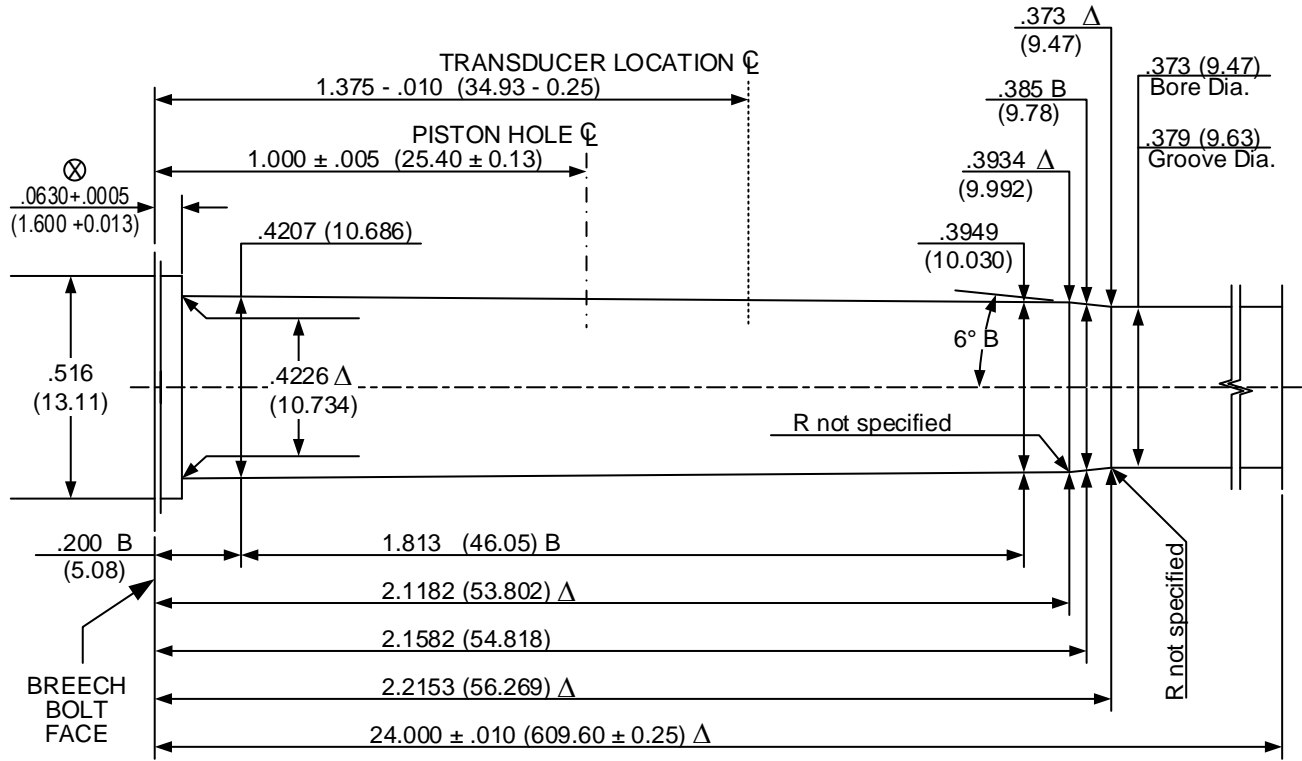

DO NOT SCALE FROM DRAWING

NUMBER OF GROOVES: 6
 WIDTH OF GROOVES: $.1171 + .002$ (2.974 + 0.051)
 TWIST RATE: 18.00 (457.2) R.H.
 DIAMETER OF PISTON HOLE: $.206$ (5.23)
 TRANSDUCER DIAMETER: $.250$ (6.53)

LAND AND GROOVE DIMENSIONS TO BE WITHIN TOLERANCES THROUGHOUT LENGTH OF BARREL.

UNLESS OTHERWISE NOTED, ALL DIAMETERS $+.0005$ (0.013) LENGTH TOLERANCE $+.005$ (0.13)

NOTE:
 B = BASIC Δ = REFERENCE DIMENSION \otimes = HEADSPACE DIMENSION
 * DIMENSIONS ARE TO INTERSECTIONS OF LINES (XX.XX) = MILLIMETERS
 ALL CALCULATIONS APPLY AT MAXIMUM MATERIAL CONDITION (MMC)

405 Winchester V&P Test Barrel

Issued: 01/24/1998

Revised: 11/18/2005

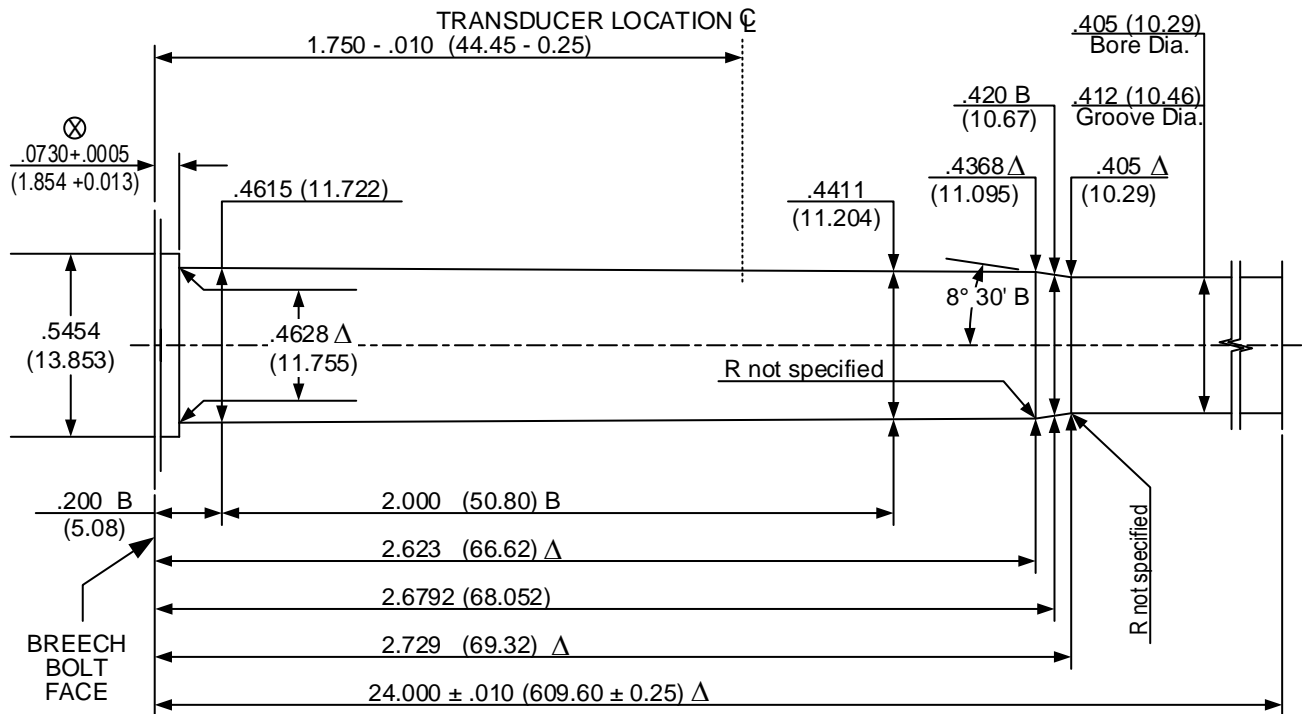

DO NOT SCALE FROM DRAWING

- NUMBER OF GROOVES: 6
- WIDTH OF GROOVES: .127 + .002 (3.23 + 0.05)
- TWIST RATE: 14.00 (255.6) R.H.
- DIAMETER OF PISTON HOLE: Crusher pressures not established
- TRANSDUCER DIAMETER: .250 (6.53)

LAND AND GROOVE DIMENSIONS TO BE WITHIN TOLERANCES THROUGHOUT LENGTH OF BARREL.

UNLESS OTHERWISE NOTED, ALL DIAMETERS +.0005 (0.013) LENGTH TOLERANCE + .005 (0.13)

NOTE:

B = BASIC Δ = REFERENCE DIMENSION ⊗ = HEADSPACE DIMENSION
 * DIMENSIONS ARE TO INTERSECTIONS OF LINES (XX.XX) = MILLIMETERS
 ALL CALCULATIONS APPLY AT MAXIMUM MATERIAL CONDITION (MMC)

416 Remington Magnum V&P Test Barrel

Issued: 04/10/1989

Revised: 11/18/2005

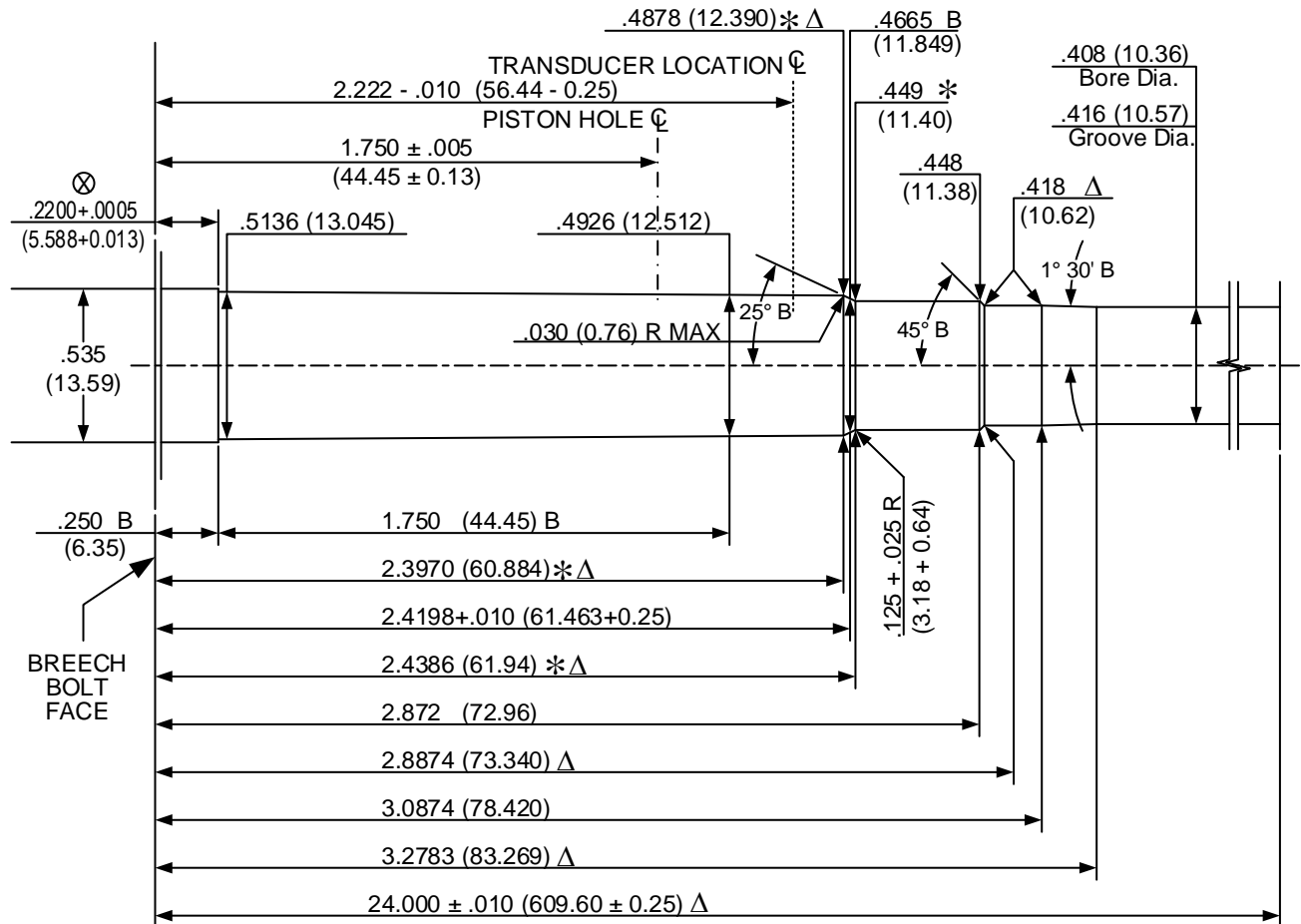

DO NOT SCALE FROM DRAWING

NUMBER OF GROOVES: 6
 WIDTH OF GROOVES: .128 + .002 (3.25 + 0.05)
 TWIST RATE: 14.00 (355.6) R.H.
 DIAMETER OF PISTON HOLE: .206 (5.23)
 TRANSDUCER DIAMETER: .250 (6.35)

LAND AND GROOVE DIMENSIONS TO BE WITHIN TOLERANCES THROUGHOUT LENGTH OF BARREL.

UNLESS OTHERWISE NOTED, ALL DIAMETERS +.0005 (0.013) LENGTH TOLERANCE + .005 (0.13)

NOTE:
 B = BASIC Δ = REFERENCE DIMENSION ⊗ = HEADSPACE DIMENSION
 * DIMENSIONS ARE TO INTERSECTIONS OF LINES (XX.XX) = MILLIMETERS
 ALL CALCULATIONS APPLY AT MAXIMUM MATERIAL CONDITION (MMC)

416 Rigby V&P Test Barrel

Issued: 09/08/1989

Revised: 11/20/2005

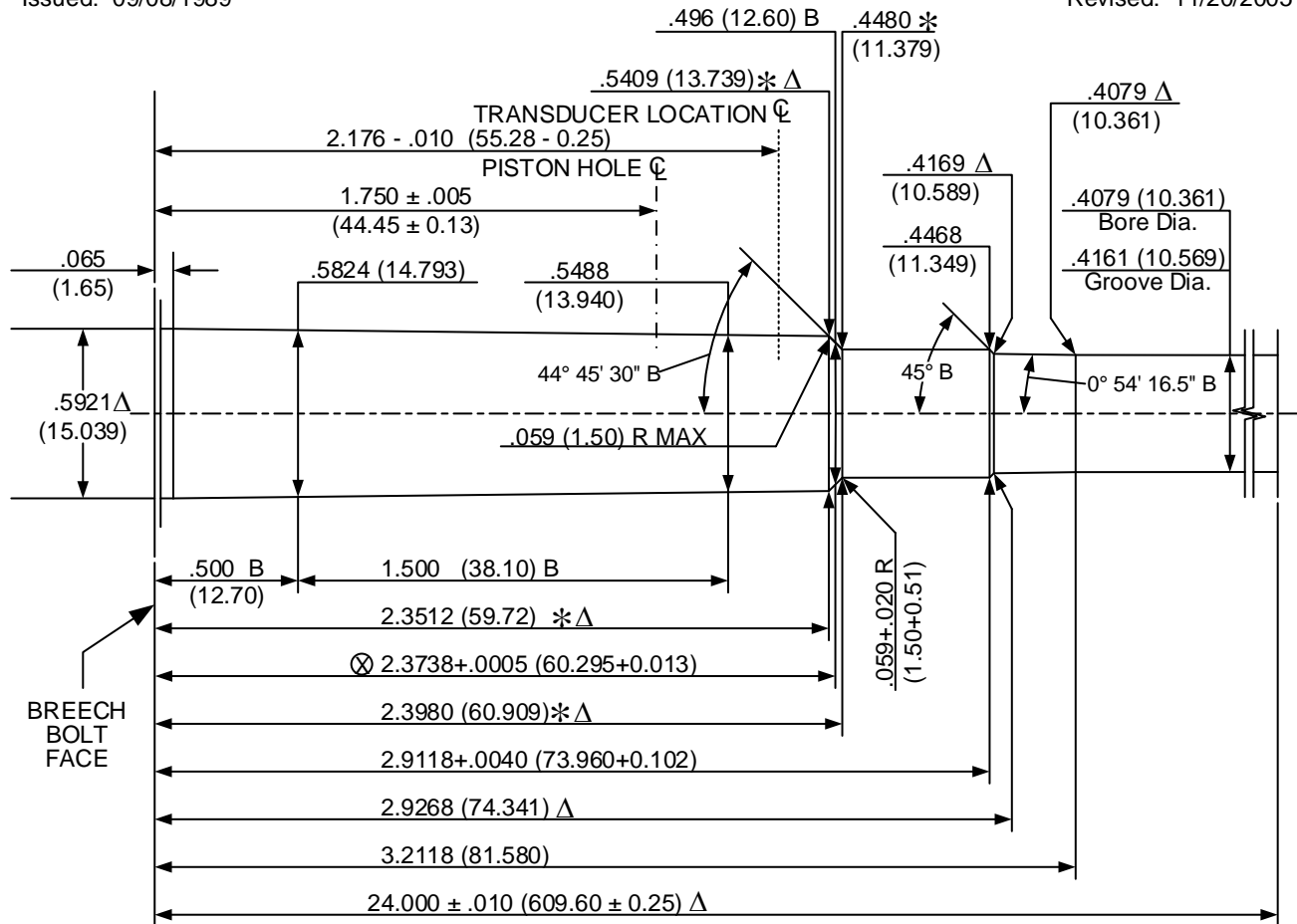

DO NOT SCALE FROM DRAWING

NUMBER OF GROOVES: 6
 WIDTH OF GROOVES: .142 + .002 (3.61 + 0.05)
 TWIST RATE: 16.535 (419.99) R.H.
 DIAMETER OF PISTON HOLE: .206 (5.23)
 TRANSDUCER DIAMETER: .250 (6.35)

LAND AND GROOVE DIMENSIONS TO BE
 WITHIN TOLERANCES THROUGHOUT
 LENGTH OF BARREL.

UNLESS OTHERWISE NOTED,
 ALL DIAMETERS +.0005 (0.013)
 LENGTH TOLERANCE + .005 (0.13)

NOTE:

B = BASIC Δ = REFERENCE DIMENSION ⊗ = HEADSPACE DIMENSION
 * DIMENSIONS ARE TO INTERSECTIONS OF LINES (XX.XX) = MILLIMETERS
 ALL CALCULATIONS APPLY AT MAXIMUM MATERIAL CONDITION (MMC)

416 Ruger V&P Test Barrel

Issued: 06/17/2009

Revised: -/-/-/-

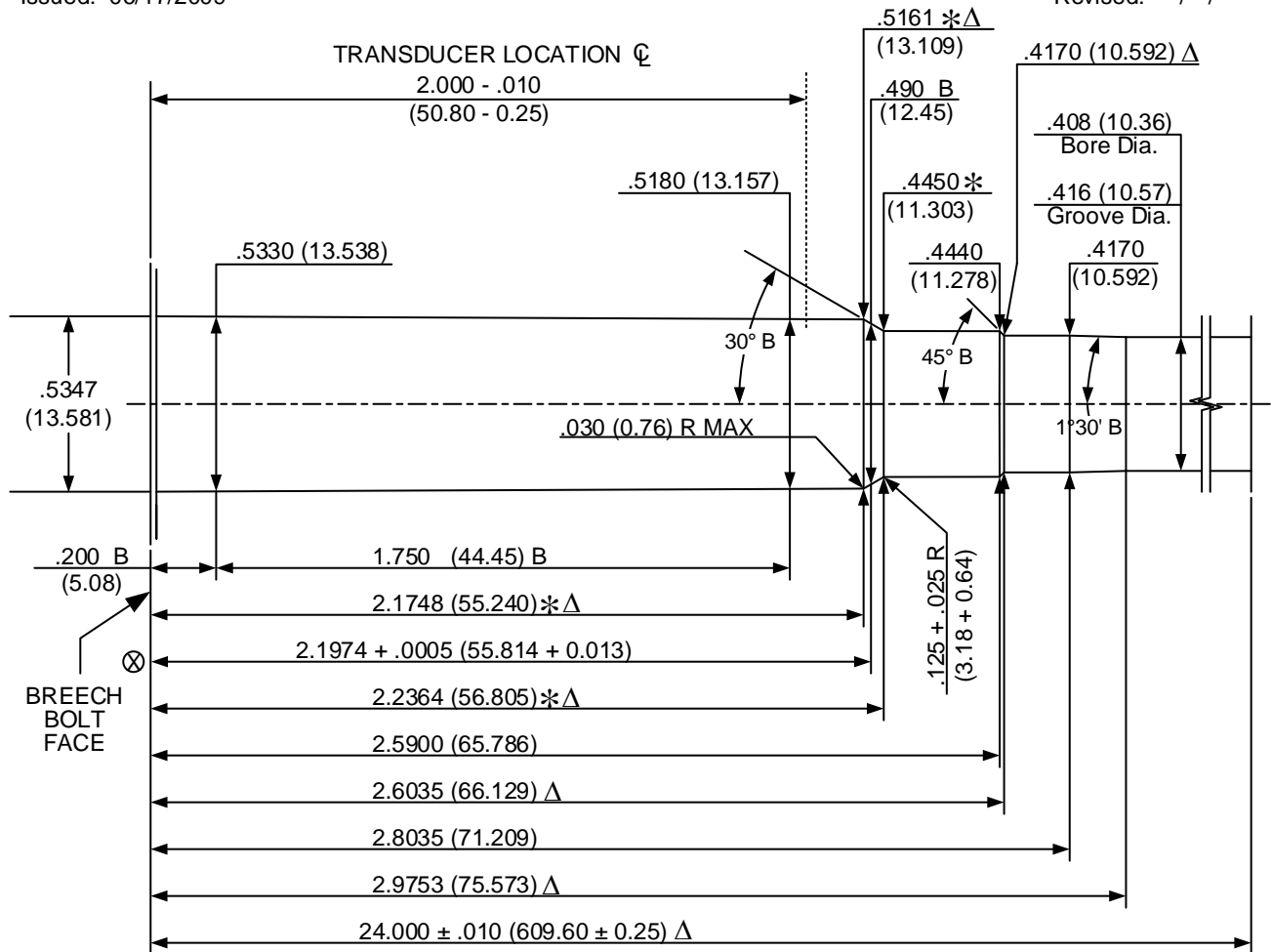

DO NOT SCALE FROM DRAWING

NUMBER OF GROOVES: 6
 WIDTH OF GROOVES: .128 + .002 (3.25 + 0.05)
 TWIST RATE: 14.00 (355.6) R.H.
 DIAMETER OF PISTON HOLE: Crusher pressures not established.
 TRANSDUCER DIAMETER: .250 (6.35)

LAND AND GROOVE DIMENSIONS TO BE WITHIN TOLERANCES THROUGHOUT LENGTH OF BARREL.

UNLESS OTHERWISE NOTED, ALL DIAMETERS +.0005 (0.013) LENGTH TOLERANCE + .005 (0.13)

NOTE:

B = BASIC Δ = REFERENCE DIMENSION \otimes = HEADSPACE DIMENSION
 * DIMENSIONS ARE TO INTERSECTIONS OF LINES (XX.XX) = MILLIMETERS
 ALL CALCULATIONS APPLY AT MAXIMUM MATERIAL CONDITION (MMC)

416 Weatherby Magnum V&P Test Barrel

Issued: 01/12/1994

Revised: 11/21/2005

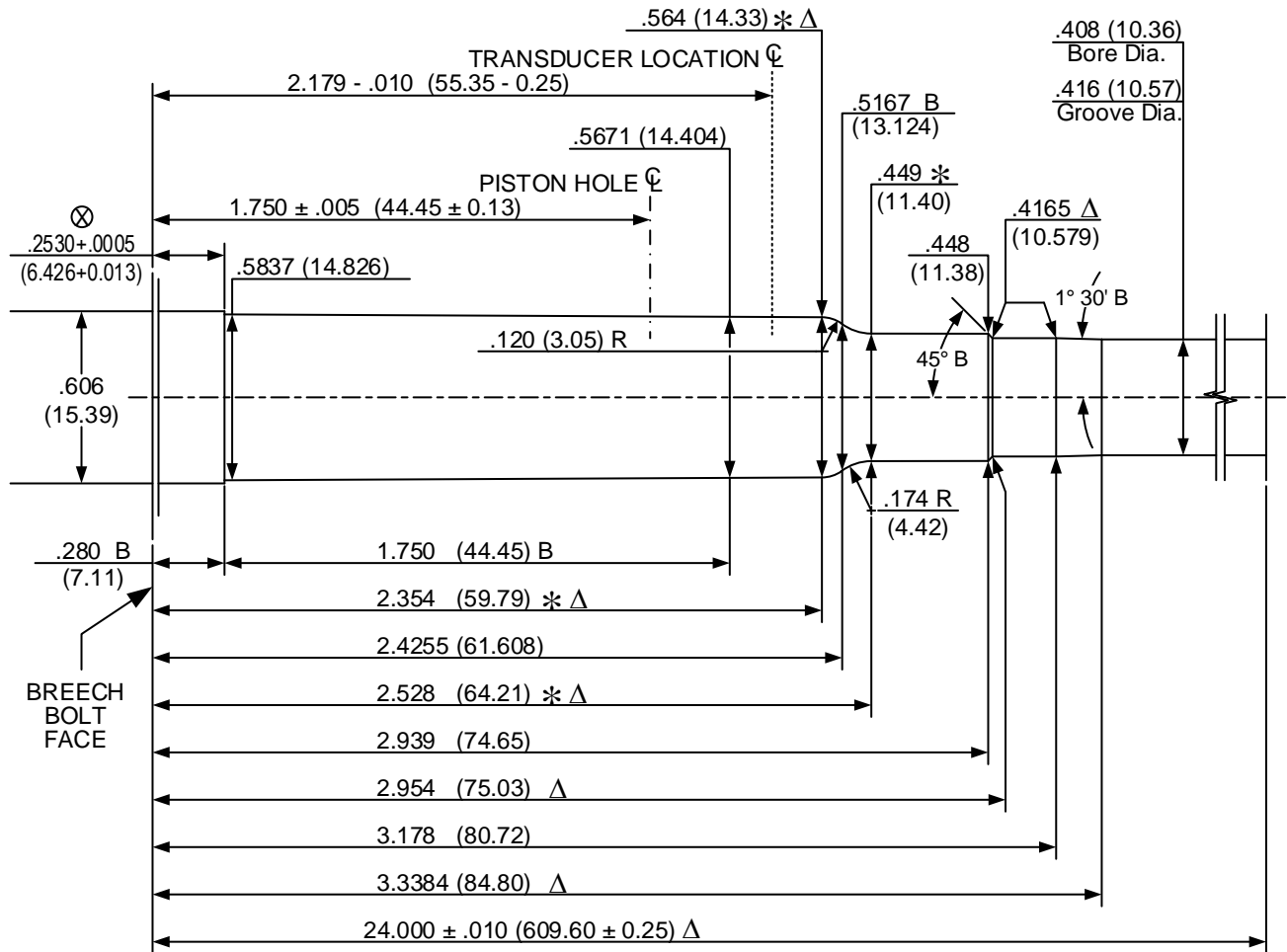

DO NOT SCALE FROM DRAWING

- NUMBER OF GROOVES: 6
- WIDTH OF GROOVES: .127 + .002 (3.23 + 0.05)
- TWIST RATE: 14.00 (355.6) R.H.
- DIAMETER OF PISTON HOLE: .206 (5.23)
- TRANSDUCER DIAMETER: .250 (6.35)

LAND AND GROOVE DIMENSIONS TO BE WITHIN TOLERANCES THROUGHOUT LENGTH OF BARREL.

UNLESS OTHERWISE NOTED, ALL DIAMETERS +.0005 (0.013) LENGTH TOLERANCE + .005 (0.13)

NOTE:

- B = BASIC Δ = REFERENCE DIMENSION ⊗ = HEADSPACE DIMENSION
- * DIMENSIONS ARE TO INTERSECTIONS OF LINES (XX.XX) = MILLIMETERS
- ALL CALCULATIONS APPLY AT MAXIMUM MATERIAL CONDITION (MMC)

44-40 Winchester V&P Test Barrel

Issued: 05/20/1980

Revised: 11/21/2005

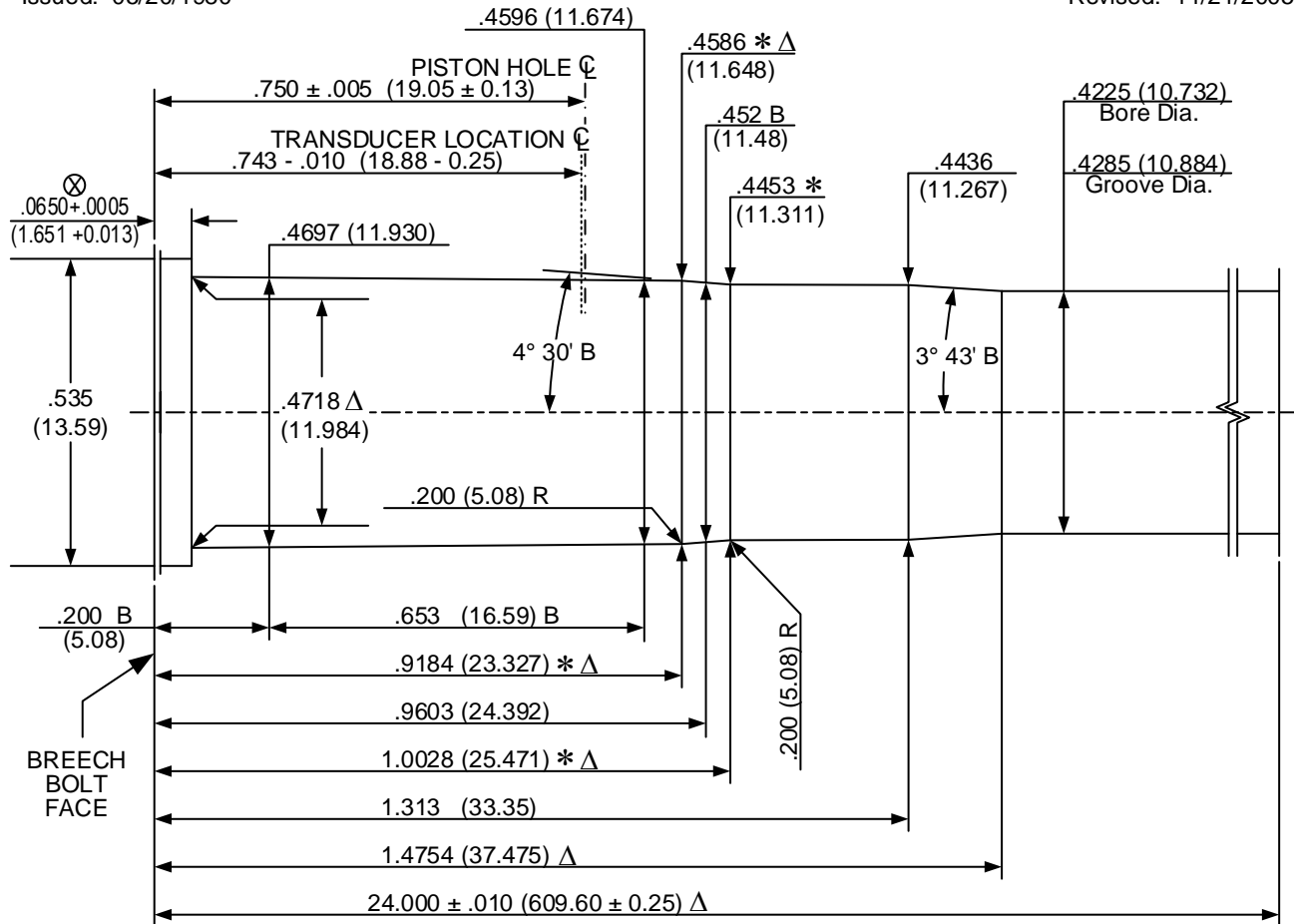

DO NOT SCALE FROM DRAWING

- NUMBER OF GROOVES: 6
- WIDTH OF GROOVES: .1327 + .0020 (3.371 + 0.051)
- TWIST RATE: 36.00 (914.4) R.H.
- DIAMETER OF PISTON HOLE: .206 (5.23)
- TRANSDUCER DIAMETER: .250 (6.53)

LAND AND GROOVE DIMENSIONS TO BE WITHIN TOLERANCES THROUGHOUT LENGTH OF BARREL.

UNLESS OTHERWISE NOTED, ALL DIAMETERS +.0005 (0.013) LENGTH TOLERANCE + .005 (0.13)

NOTE:

- B = BASIC
- Δ = REFERENCE DIMENSION
- ⊗ = HEADSPACE DIMENSION
- * DIMENSIONS ARE TO INTERSECTIONS OF LINES
- (XX.XX) = MILLIMETERS
- ALL CALCULATIONS APPLY AT MAXIMUM MATERIAL CONDITION (MMC)

444 Marlin V&P Test Barrel

Issued: 05/20/1980

Revised: 11/22/2005

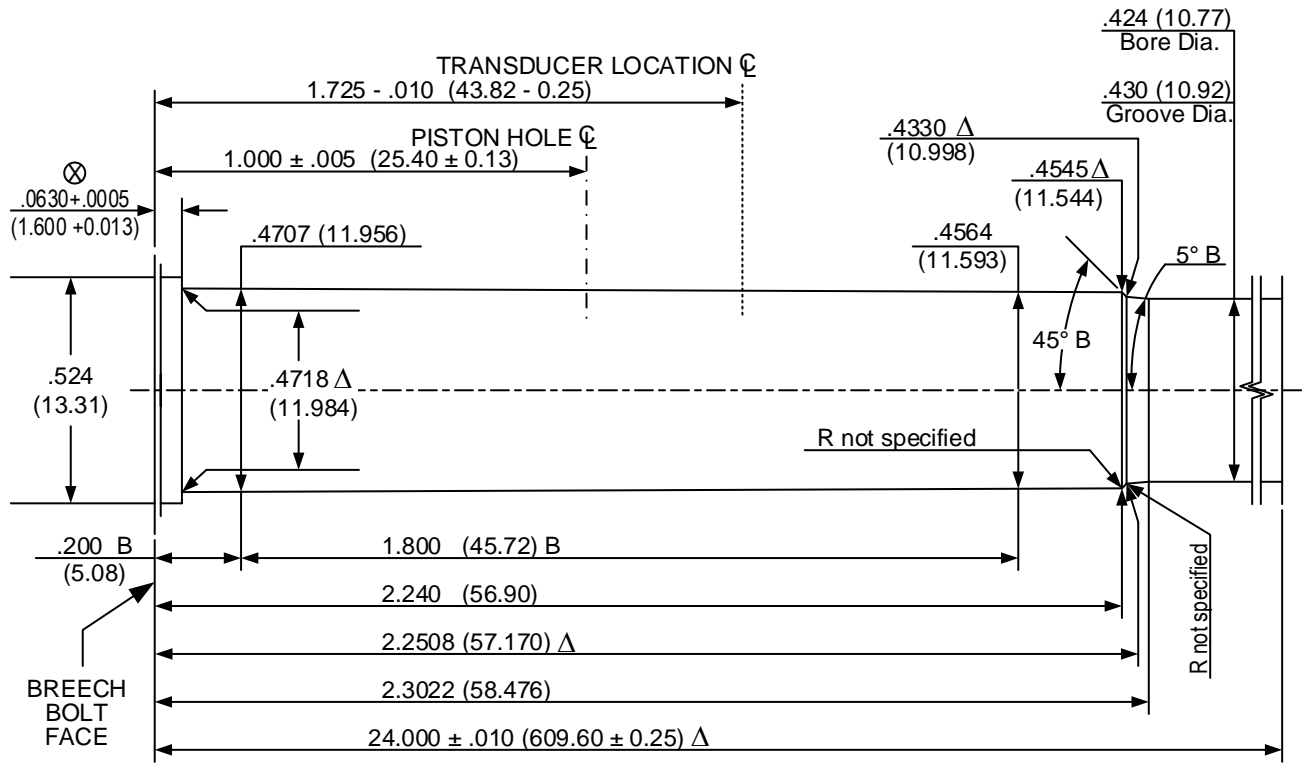

DO NOT SCALE FROM DRAWING

NUMBER OF GROOVES: 12
 WIDTH OF GROOVES: .062 + .002 (1.57 + 0.05)
 TWIST RATE: 38.00 (965.2) R.H.
 DIAMETER OF PISTON HOLE: .206 (5.23)
 TRANSDUCER DIAMETER: .250 (6.53)

LAND AND GROOVE DIMENSIONS TO BE WITHIN TOLERANCES THROUGHOUT LENGTH OF BARREL.

UNLESS OTHERWISE NOTED, ALL DIAMETERS +.0005 (0.013) LENGTH TOLERANCE + .005 (0.13)

NOTE:

B = BASIC Δ = REFERENCE DIMENSION ⊗ = HEADSPACE DIMENSION
 * DIMENSIONS ARE TO INTERSECTIONS OF LINES (XX.XX) = MILLIMETERS
 ALL CALCULATIONS APPLY AT MAXIMUM MATERIAL CONDITION (MMC)

45-70 Government V&P Test Barrel

Issued: 05/20/1980

Revised: 11/25/2005

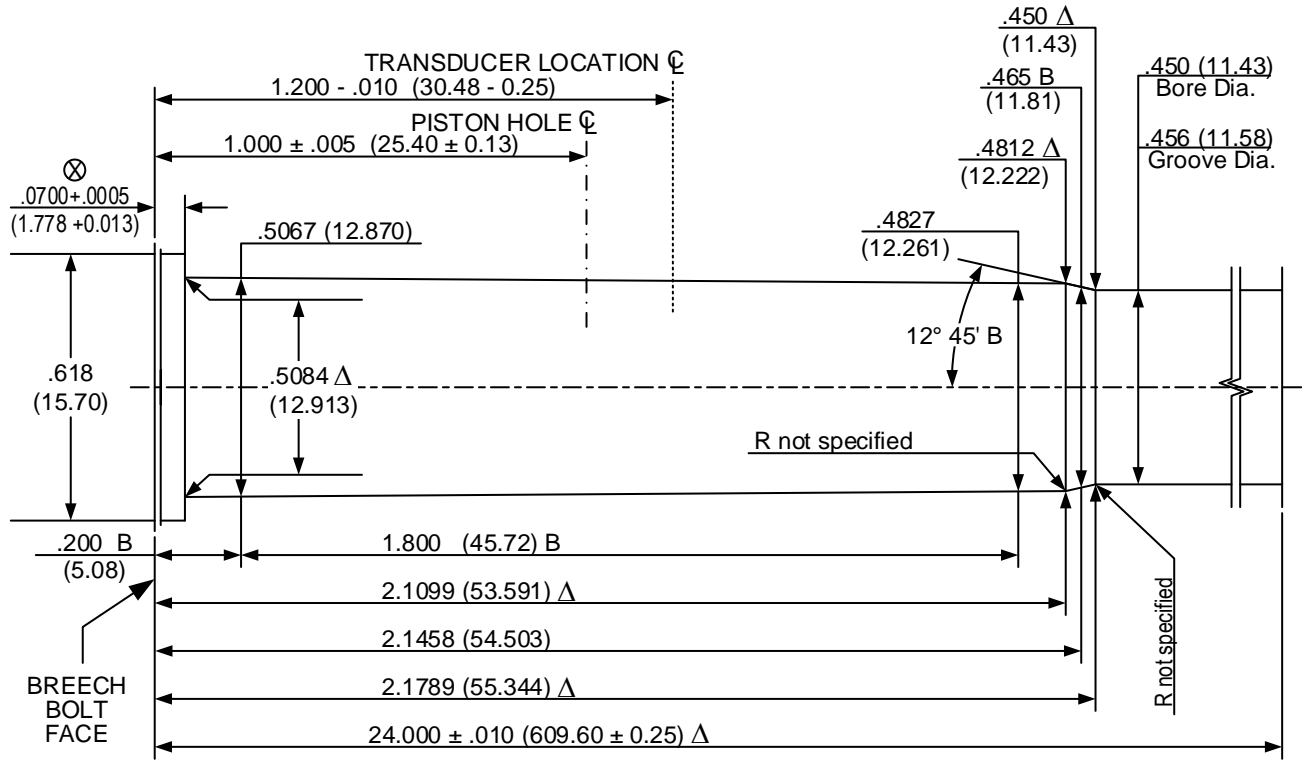

DO NOT SCALE FROM DRAWING

- NUMBER OF GROOVES: 6
- WIDTH OF GROOVES: .141 + .002 (3.58 + 0.05)
- TWIST RATE: 20.00 (508.0) R.H.
- DIAMETER OF PISTON HOLE: .206 (5.23)
- TRANSDUCER DIAMETER: .250 (6.53)

LAND AND GROOVE DIMENSIONS TO BE WITHIN TOLERANCES THROUGHOUT LENGTH OF BARREL.

UNLESS OTHERWISE NOTED, ALL DIAMETERS +.0005 (0.013) LENGTH TOLERANCE + .005 (0.13)

NOTE:

B = BASIC Δ = REFERENCE DIMENSION ⊗ = HEADSPACE DIMENSION
 * DIMENSIONS ARE TO INTERSECTIONS OF LINES (XX.XX) = MILLIMETERS
 ALL CALCULATIONS APPLY AT MAXIMUM MATERIAL CONDITION (MMC)

450 Bushmaster V&P Test Barrel

Issued: 09/09/2007

Revised: 02/01/2008

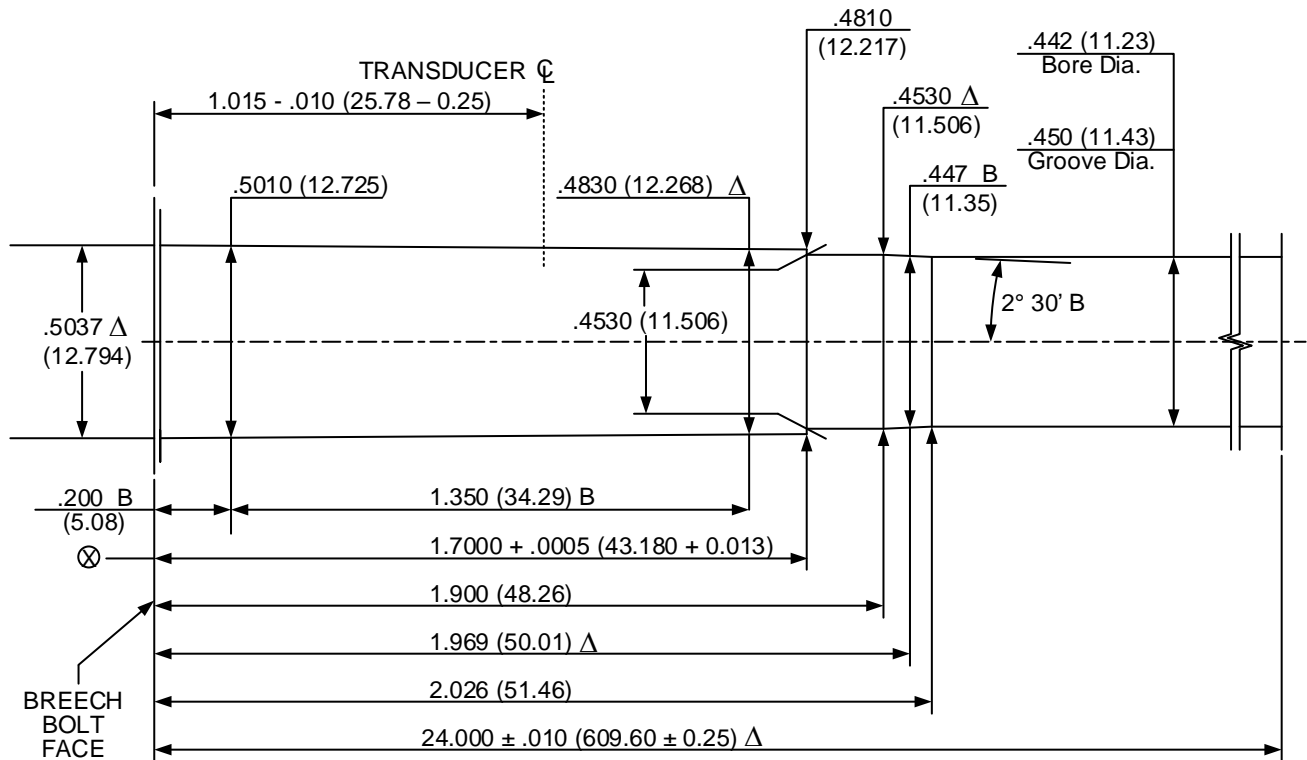

DO NOT SCALE FROM DRAWING

NUMBER OF GROOVES: 6
 WIDTH OF GROOVES: .148 + .002 (3.76 + 0.050)
 TWIST RATE: 24 (609.6) R.H.
 DIAMETER OF PISTON HOLE: Crusher pressures not established
 TRANSDUCER DIAMETER: .250 (6.35)

LAND AND GROOVE DIMENSIONS TO BE
 WITHIN TOLERANCES THROUGHOUT
 LENGTH OF BARREL.

UNLESS OTHERWISE NOTED,
 ALL DIAMETERS +.0005 (0.013)
 LENGTH TOLERANCE + .005 (0.13)

NOTE:

B = BASIC Δ = REFERENCE DIMENSION ⊗ = HEADSPACE DIMENSION
 * DIMENSIONS ARE TO INTERSECTIONS OF LINES (XX.XX) = MILLIMETERS
 ALL CALCULATIONS APPLY AT MAXIMUM MATERIAL CONDITION (MMC)

450 Marlin V&P Test Barrel

Issued: 01/10/2001

Revised: 11/29/2005

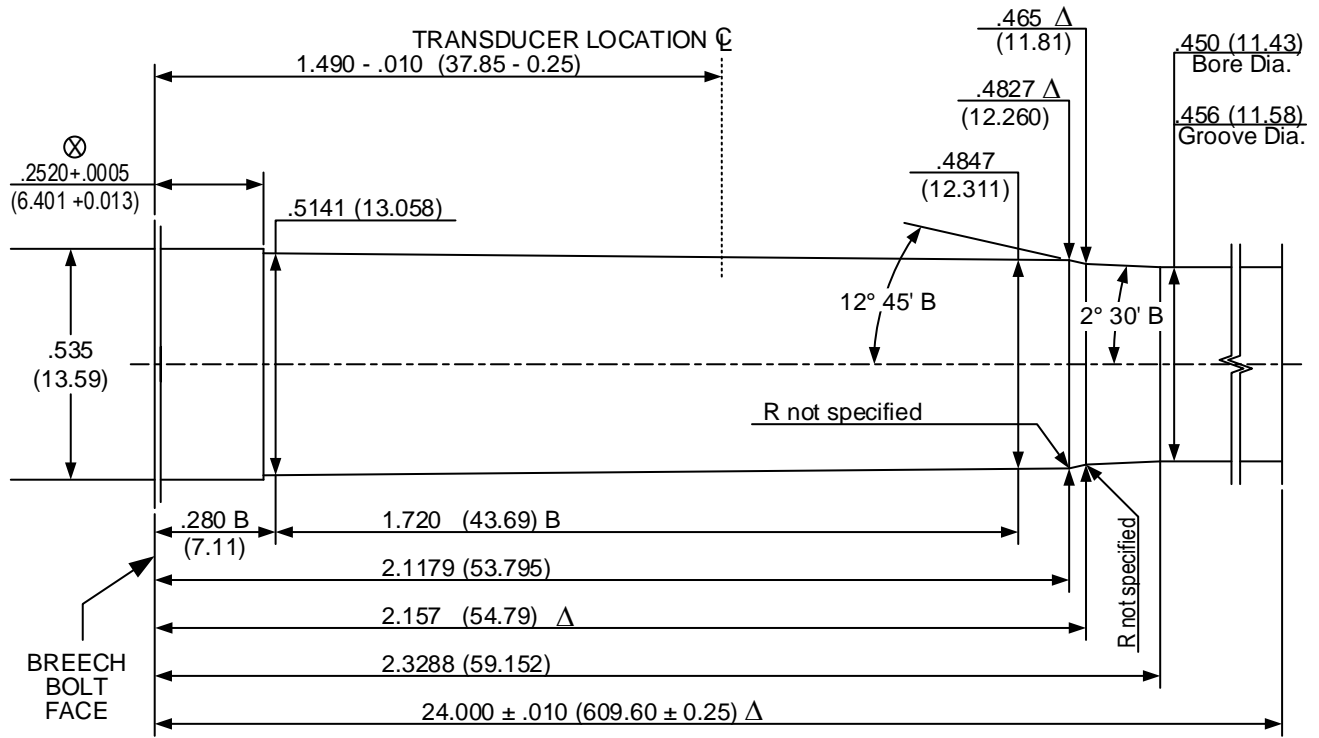

DO NOT SCALE FROM DRAWING

NUMBER OF GROOVES: 6
 WIDTH OF GROOVES: .141 + .002 (3.58 + 0.05)
 TWIST RATE: 20.00 (508.0) R.H.
 DIAMETER OF PISTON HOLE: Crusher pressures not established
 TRANSDUCER DIAMETER: .250 (6.53)

LAND AND GROOVE DIMENSIONS TO BE
 WITHIN TOLERANCES THROUGHOUT
 LENGTH OF BARREL.

UNLESS OTHERWISE NOTED,
 ALL DIAMETERS +.0005 (0.013)
 LENGTH TOLERANCE + .005 (0.13)

NOTE:

B = BASIC Δ = REFERENCE DIMENSION ⊗ = HEADSPACE DIMENSION
 * DIMENSIONS ARE TO INTERSECTIONS OF LINES (XX.XX) = MILLIMETERS
 ALL CALCULATIONS APPLY AT MAXIMUM MATERIAL CONDITION (MMC)

457 Wild West Guns V&P Test Barrel

Issued: 01/13/2014

Revised: -/-/-/-

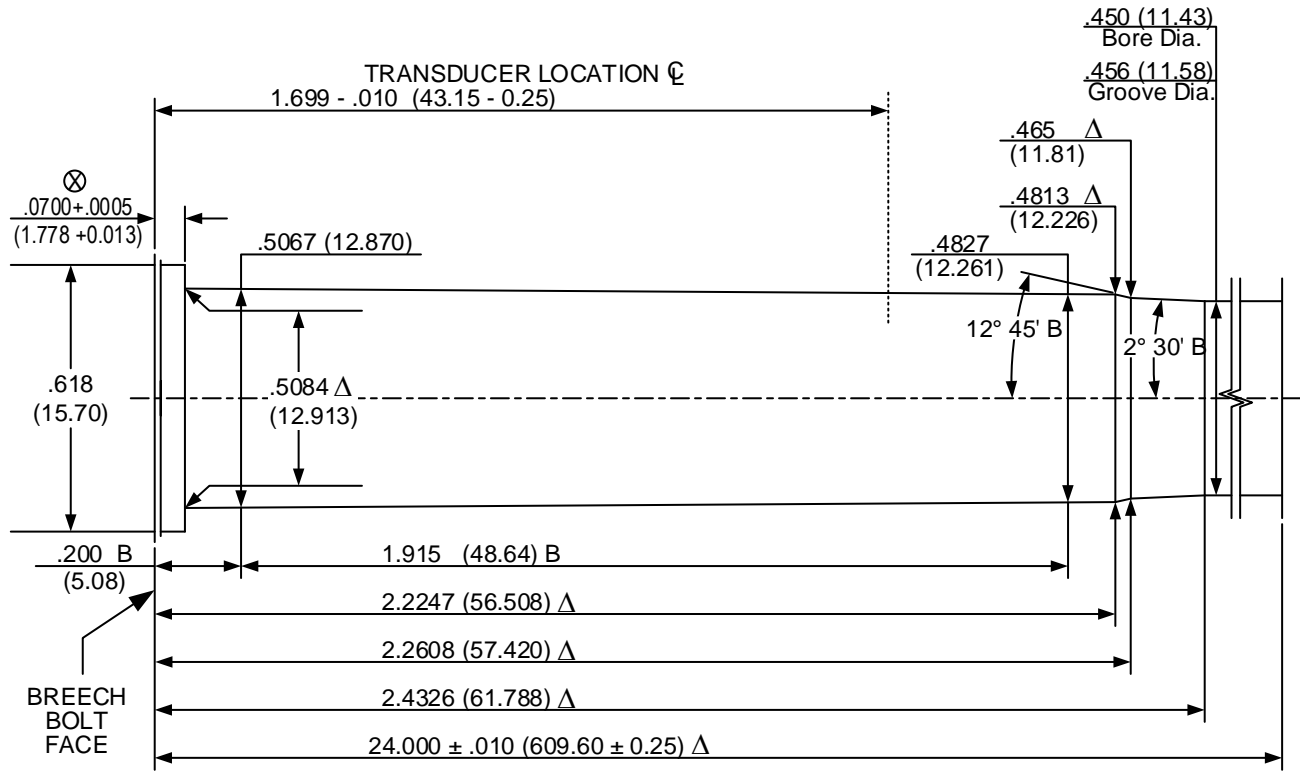

DO NOT SCALE FROM DRAWING

- NUMBER OF GROOVES: 6
- WIDTH OF GROOVES: .141 + .002 (3.58 + 0.05)
- TWIST RATE: 20.00 (508.0) R.H.
- DIAMETER OF PISTON HOLE: Crusher pressures not established
- TRANSDUCER DIAMETER: .250 (6.53)

LAND AND GROOVE DIMENSIONS TO BE WITHIN TOLERANCES THROUGHOUT LENGTH OF BARREL.

UNLESS OTHERWISE NOTED, ALL DIAMETERS +.0005 (0.013) LENGTH TOLERANCE + .005 (0.13)

NOTE:

B = BASIC Δ = REFERENCE DIMENSION ⊗ = HEADSPACE DIMENSION
 * DIMENSIONS ARE TO INTERSECTIONS OF LINES (XX.XX) = MILLIMETERS
 ALL CALCULATIONS APPLY AT MAXIMUM MATERIAL CONDITION (MMC)

458 Lott V&P Test Barrel

Issued: 06/04/1998

Revised: 11/25/2005

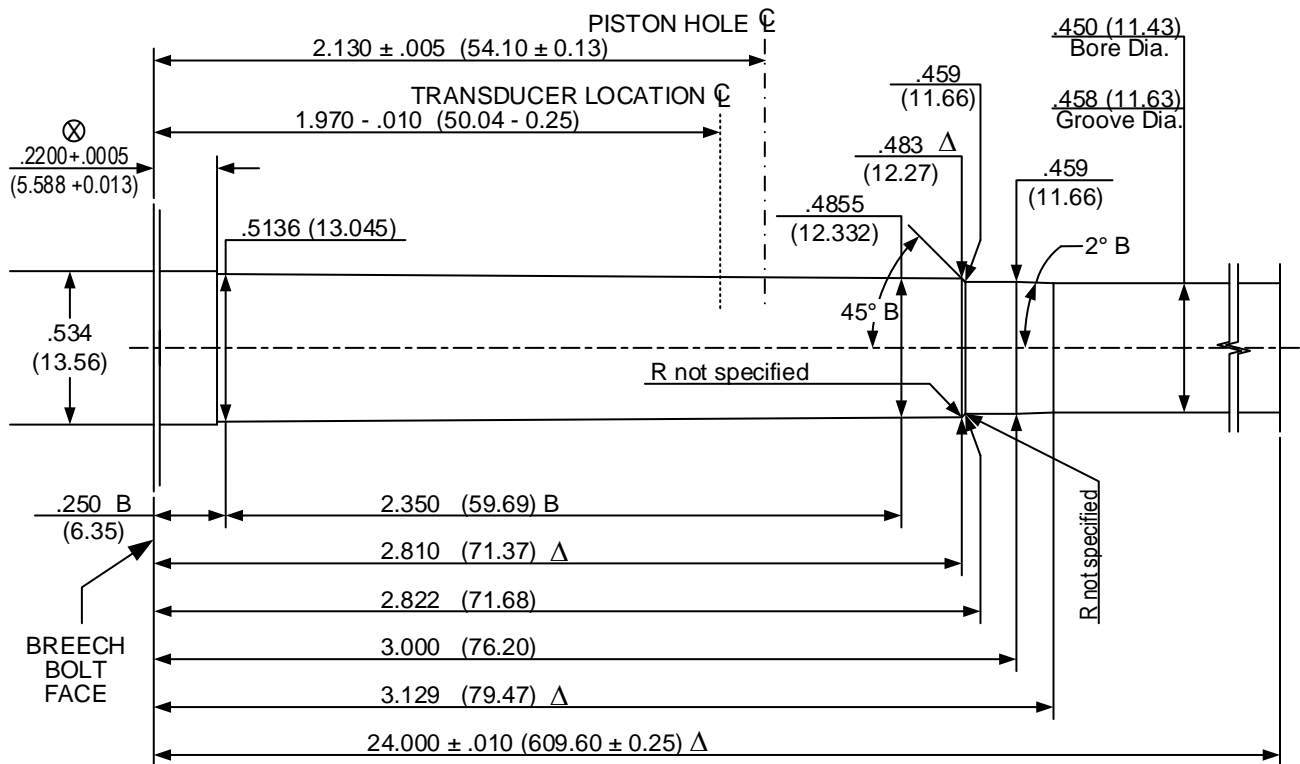

DO NOT SCALE FROM DRAWING

- NUMBER OF GROOVES: 6
- WIDTH OF GROOVES: .150 + .002 (3.81 + 0.05)
- TWIST RATE: 10.00 (254.0) R.H.
- DIAMETER OF PISTON HOLE: .206 (5.23)
- TRANSDUCER DIAMETER: .250 (6.53)

LAND AND GROOVE DIMENSIONS TO BE WITHIN TOLERANCES THROUGHOUT LENGTH OF BARREL.

UNLESS OTHERWISE NOTED, ALL DIAMETERS +.0005 (0.013) LENGTH TOLERANCE + .005 (0.13)

NOTE:

- B = BASIC
- Δ = REFERENCE DIMENSION
- ⊗ = HEADSPACE DIMENSION
- * DIMENSIONS ARE TO INTERSECTIONS OF LINES
- (XX.XX) = MILLIMETERS
- ALL CALCULATIONS APPLY AT MAXIMUM MATERIAL CONDITION (MMC)

458 Winchester Magnum V&P Test Barrel

Issued: 05/20/1980

Revised: 11/25/2005

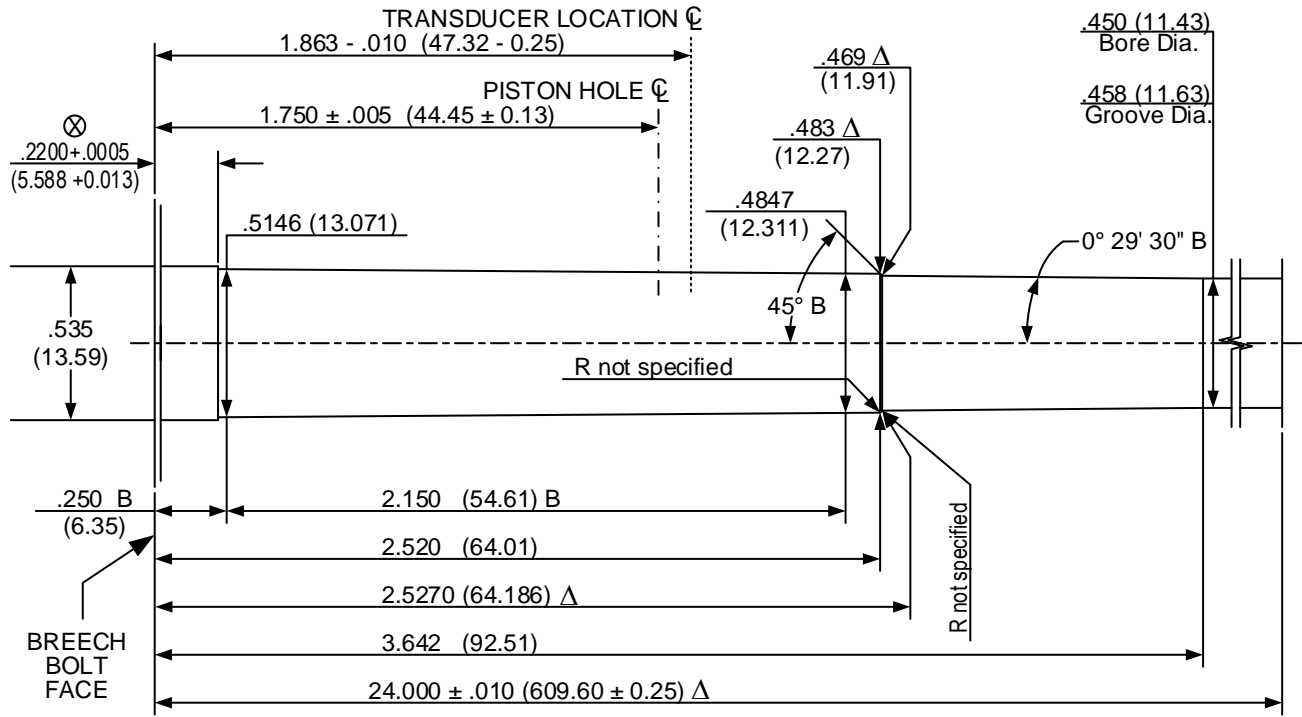

DO NOT SCALE FROM DRAWING

NUMBER OF GROOVES: 6
 WIDTH OF GROOVES: $.150 + .002$ (3.81 + 0.05)
 TWIST RATE: 14.00 (355.6) R.H.
 DIAMETER OF PISTON HOLE: $.206$ (5.23)
 TRANSDUCER DIAMETER: $.250$ (6.53)

LAND AND GROOVE DIMENSIONS TO BE WITHIN TOLERANCES THROUGHOUT LENGTH OF BARREL.

UNLESS OTHERWISE NOTED, ALL DIAMETERS $+ .0005$ (0.013) LENGTH TOLERANCE $+ .005$ (0.13)

NOTE:

B = BASIC Δ = REFERENCE DIMENSION $\textcircled{\otimes}$ = HEADSPACE DIMENSION
 * DIMENSIONS ARE TO INTERSECTIONS OF LINES (XX.XX) = MILLIMETERS
 ALL CALCULATIONS APPLY AT MAXIMUM MATERIAL CONDITION (MMC)

470 Nitro Express V&P Test Barrel

Issued: 09/08/1989

Revised: 02/05/2009

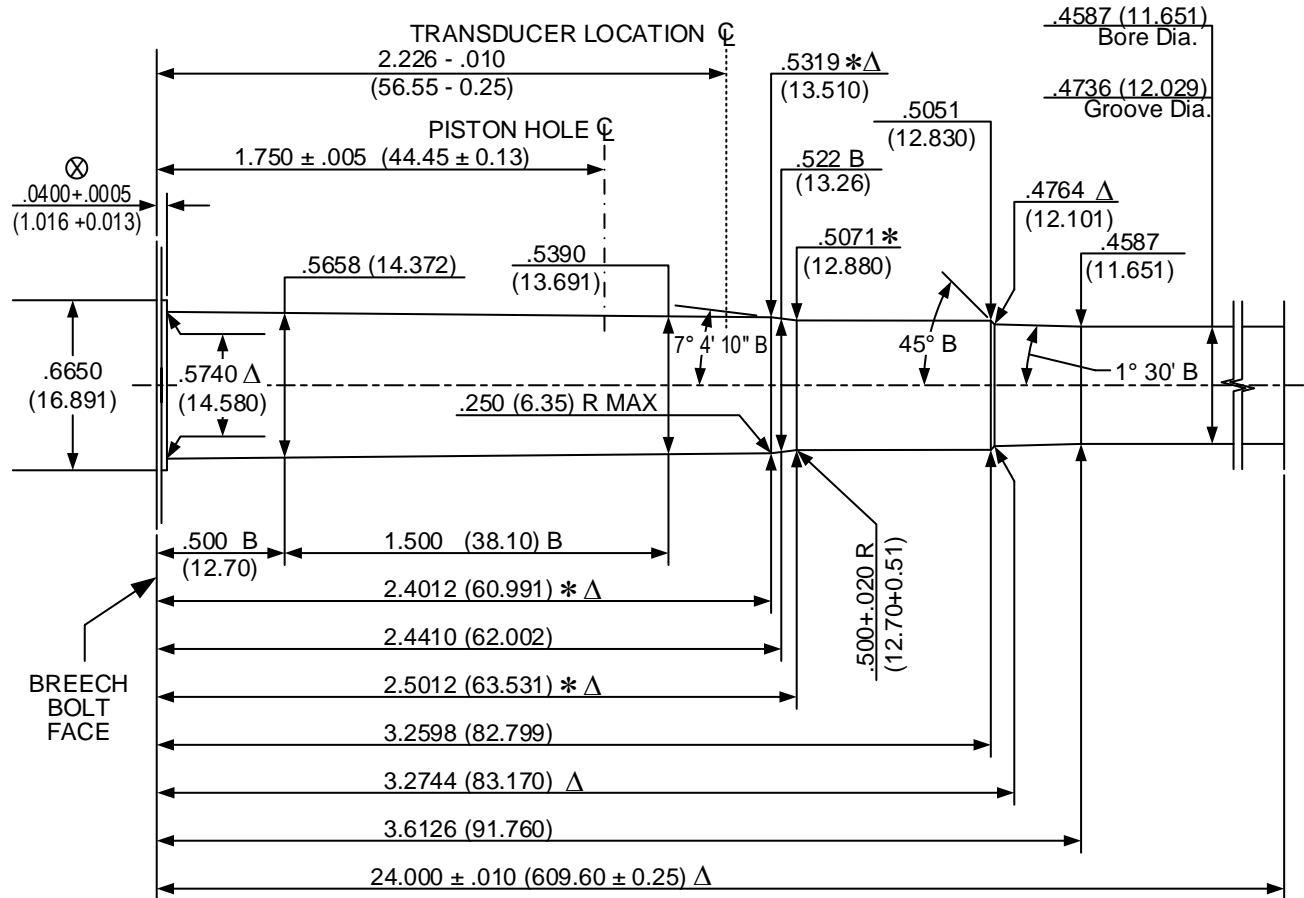

DO NOT SCALE FROM DRAWING

- NUMBER OF GROOVES: 6
- WIDTH OF GROOVES: .160 + .002 (4.06 + 0.05)
- TWIST RATE: 20.00 (508.0) R.H.
- DIAMETER OF PISTON HOLE: .206 (5.23)
- TRANSDUCER DIAMETER: .250 (6.35)

LAND AND GROOVE DIMENSIONS TO BE WITHIN TOLERANCES THROUGHOUT LENGTH OF BARREL.

UNLESS OTHERWISE NOTED, ALL DIAMETERS +.0005 (0.013) LENGTH TOLERANCE + .005 (0.13)

NOTE:

B = BASIC Δ = REFERENCE DIMENSION ⊗ = HEADSPACE DIMENSION
 * DIMENSIONS ARE TO INTERSECTIONS OF LINES (XX.XX) = MILLIMETERS
 ALL CALCULATIONS APPLY AT MAXIMUM MATERIAL CONDITION (MMC)

475 Turnbull V&P Test Barrel

Issued: 01/18/2010

Revised: -/-/- - - -

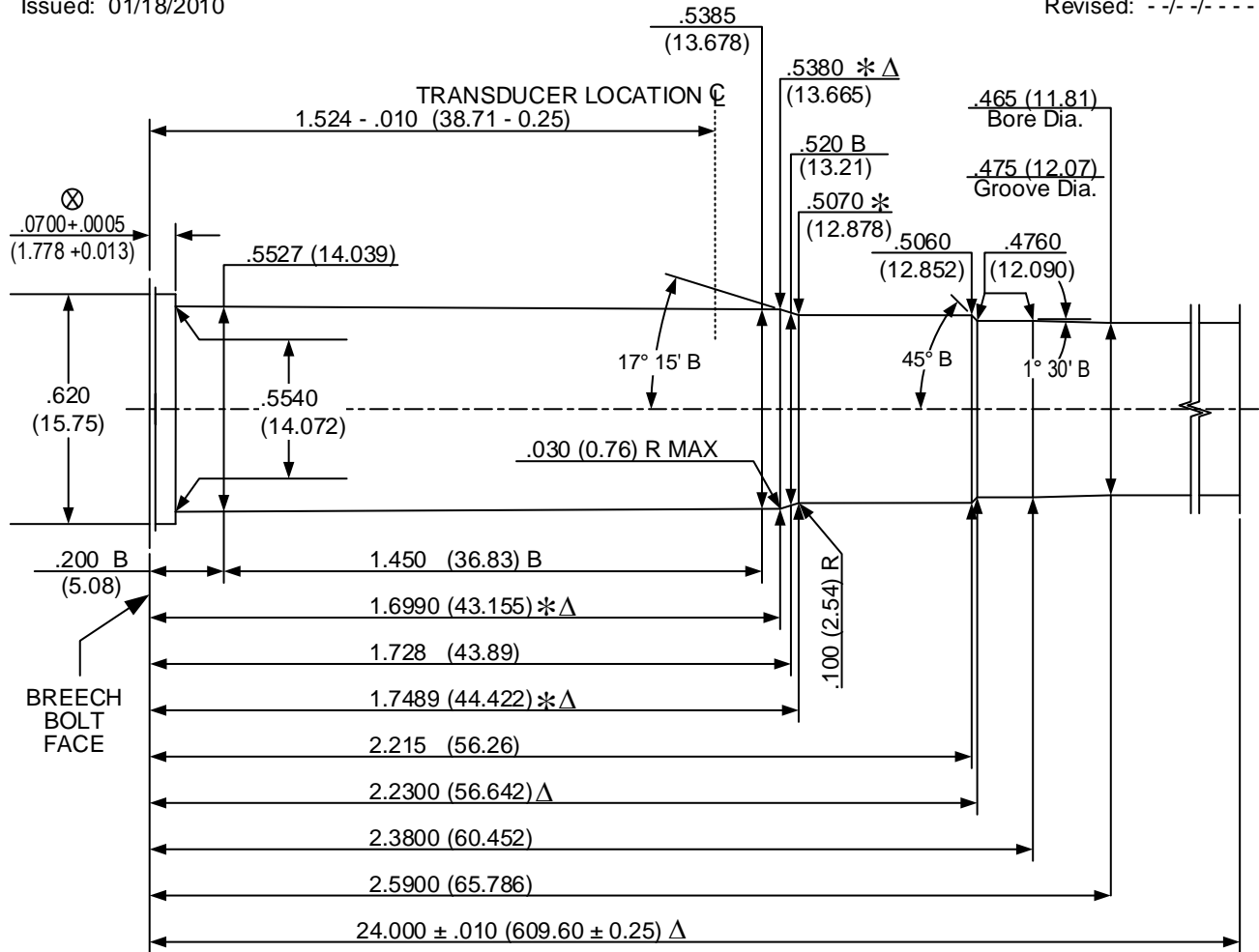

DO NOT SCALE FROM DRAWING

- NUMBER OF GROOVES: 6
- WIDTH OF GROOVES: .120 + .002 (3.05 + 0.05)
- TWIST RATE: 15.00 (381.0) R.H.
- DIAMETER OF PISTON HOLE: Crusher pressures not established
- TRANSDUCER DIAMETER: .250 (6.53)

LAND AND GROOVE DIMENSIONS TO BE WITHIN TOLERANCES THROUGHOUT LENGTH OF BARREL.

UNLESS OTHERWISE NOTED, ALL DIAMETERS +.0005 (0.013) LENGTH TOLERANCE + .005 (0.13)

NOTE:

B = BASIC Δ = REFERENCE DIMENSION ⊗ = HEADSPACE DIMENSION
 * DIMENSIONS ARE TO INTERSECTIONS OF LINES (XX.XX) = MILLIMETERS
 ALL CALCULATIONS APPLY AT MAXIMUM MATERIAL CONDITION (MMC)

500 Nitro Express 3" V&P Test Barrel

Issued: 01/02/2014

Revised: - / - / - - -

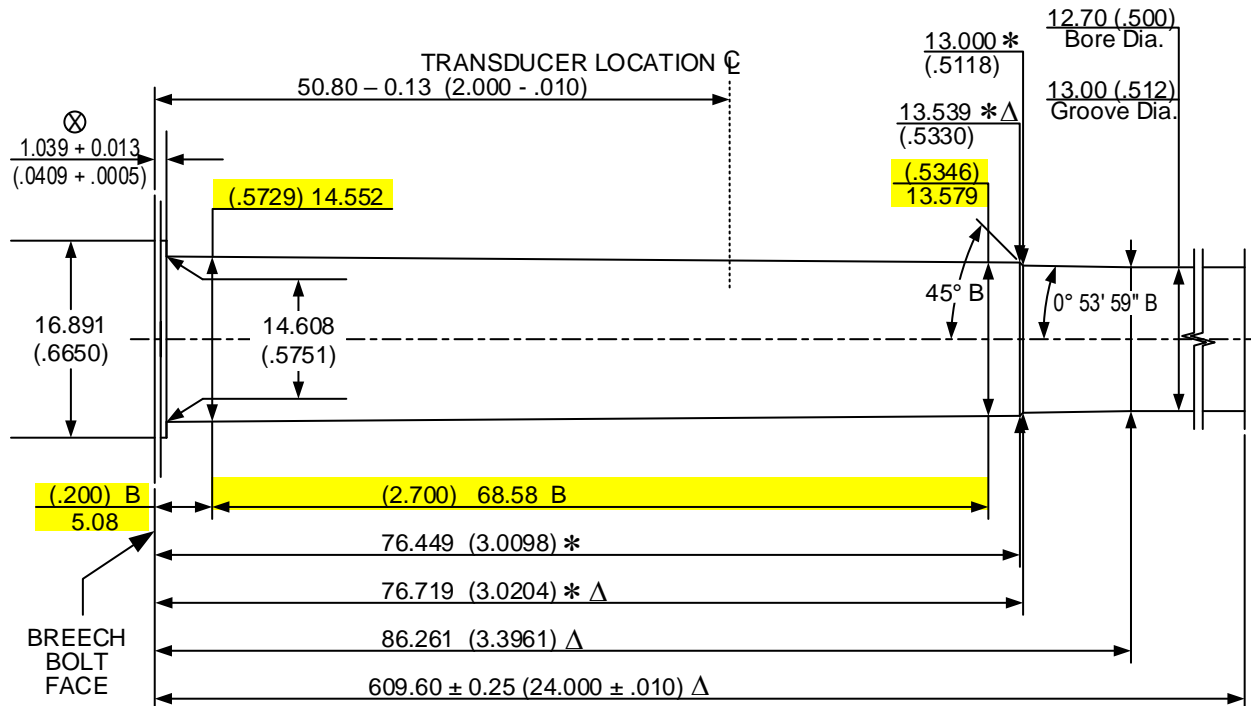

HIGHLIGHTED DIMENSIONS HAVE NO CORRESPONDING C.I.P. ANALOG. THE ENGLISH UNITS FOR THESE ARE THE ORIGINAL VALUES; METRIC VALUES ARE CALCULATED AND ROUNDED.

DO NOT SCALE FROM DRAWING

- NUMBER OF GROOVES: 7
- WIDTH OF GROOVES: 3.61 + 0.05 (.142 + .002)
- TWIST RATE: 381.0 (15.00) R.H.
- DIAMETER OF PISTON HOLE: Crusher pressures not established
- TRANSDUCER DIAMETER: 6.35 (.250)

LAND AND GROOVE DIMENSIONS TO BE WITHIN TOLERANCES THROUGHOUT LENGTH OF BARREL.

UNLESS OTHERWISE NOTED, ALL DIAMETERS +0.013(.0005) LENGTH TOLERANCE +0.13 (.005)

NOTE:

- B = BASIC
- Δ = REFERENCE DIMENSION
- ⊗ = HEADSPACE DIMENSION
- * DIMENSIONS ARE TO INTERSECTIONS OF LINES
- (XX.XXXX) = INCHES
- ALL CALCULATIONS APPLY AT MAXIMUM MATERIAL CONDITION (MMC)

METRIC

METRIC

METRIC

METRIC

DEFINITION AND PURPOSE

SAAMI Definitive Proof cartridges are cartridges commercially loaded by SAAMI member companies which develop pressure substantially exceeding those developed by normal service loads. The pressure levels are designed to assure gun safety when using ammunition loaded to service pressures in accordance with accepted American practices.

Proof cartridges are designed to stress firearms components which contain the cartridge in order to assure safety in the recommended use of the firearm during its service life.

It is important from the safety standpoint that Definitive Proof cartridges be used **only** for the proof of firearms. Adequate precaution must be taken to protect personnel performing firearms proof testing.

The supply of Definitive Proof cartridges will be the responsibility of the company that first introduced that particular caliber to the Institute. Definitive Proof Cartridges should be loaded with the heaviest bullet used at the time of introduction and the slowest powder which will meet the pressure values indicated for that particular cartridge to maintain effective pressure-distance relationship. Once established, the bullet weight for the proof load does not change unless the bullet becomes obsolete. All changes in Definitive Proof cartridges bullet weight must be approved by the Joint Technical Committee.

NOTE: The heat treatment of cartridge cases for definitive proof loads may be different from the treatment of service cases, at the option of the manufacturer.

Other case modifications to minimize firing casualties such as gas leakage around primers are also permissible. The use of such options must not affect the stressing of the firearm's components.

PROOF PRESSURE DATA - CRUSHER

Cartridge	Bullet Weight (grains)	SERVICE Maximum Average Pressure (CUP/100)	Pressure Values of Proof Cartridges ⁽¹⁾		
			Minimum Average (CUP/100)	Maximum Average (CUP/100)	Maximum E.V. (CUP/100)
6 x 45mm	80		Crusher Pressures Not Established		
6mm Remington	100	520	695	745	135
6.5 Creedmoor	140		Crusher Pressures Not Established		
6.5 Grendel	123		Crusher Pressures Not Established		
6.5 x 55 Swedish	140	460	615	660	119
6.8mm Remington SPC	115		Crusher Pressures Not Established		
7mm Mauser (7x57)	175	460	615	660	119
7mm Remington Magnum	175	520	695	745	135
7mm Remington Short Action Ultra Magnum			Crusher Pressures Not Established		
7mm Remington Ultra Magnum			Crusher Pressures Not Established		
7mm Shooting Times Westerner	160	530	710	760	137
7mm Weatherby Magnum			Crusher Pressures Not Established		
7mm Winchester Short Magnum			Crusher Pressures Not Established		
7mm-08 Remington	140	520	695	745	135
7 x 64 Brenneke	175	505	675	725	131
7-30 Waters	120	400	535	570	104
7.62 x 39	123	500	670	715	129
8mm Mauser (8x57)	170	370	495	530	96
8mm Remington Magnum	220	540	725	775	140
9.3 x 62	286		Crusher Pressures Not Established		
17 Hornet	20		Crusher Pressures Not Established		
17 Remington	25	520	695	745	135
17 Remington Fireball	20		Crusher Pressures Not Established		
204 Ruger	32		Crusher Pressures Not Established		
218 Bee	46	400	535	570	104
22 Hornet	45	430	575	615	111
22-250 Remington	55	530	710	760	137
220 Swift	60	540	725	775	140
221 Remington Fireball	50	520	695	745	135
222 Remington	55	460	615	660	119
222 Remington Magnum	55	500	670	715	129
223 Remington	64	520	695	745	135
223 Winchester Super Short Magnum			Crusher Pressures Not Established		
225 Winchester	55	500	670	715	129
243 Winchester	100	520	695	745	135
243 Winchester Super Short Magnum	100		Crusher Pressures Not Established		

⁽¹⁾ Based on sample size $\eta=10$.

PROOF PRESSURE DATA - CRUSHER (Continued)

Cartridge	Bullet Weight (grains)	SERVICE Maximum Average Pressure (CUP/100)	Pressure Values of Proof Cartridges ⁽¹⁾		
			Minimum Average (CUP/100)	Maximum Average (CUP/100)	Maximum E.V. (CUP/100)
25 Winchester Super Short Magnum	85		Crusher Pressures Not Established		
25-06 Remington	120	530	710	760	137
25-20 Winchester	86	280	375	400	73
25-35 Winchester	117	370	495	530	96
250 Savage	100	450	600	645	117
257 Roberts			Obsolete – Use 257 Roberts +P Only		
257 Roberts +P	117	500	670	715	129
257 Weatherby Magnum	120	535	715	765	139
26 Nosler	129		Crusher Pressures Not Established		
260 Remington	120		Crusher Pressures Not Established		
264 Winchester Magnum	140	540	725	775	140
27 Nosler	150		Crusher Pressures Not Established		
270 Weatherby Magnum	150	535	715	765	139
270 Winchester	150	520	695	745	135
270 Winchester Short Magnum	150		Crusher Pressures Not Established		
28 Nosler	168		Crusher Pressures Not Established		
280 Ackley Improved	140		Crusher Pressures Not Established		
280 Remington	165	500	670	715	129
284 Winchester	150	540	725	775	140
30 Carbine	110	400	535	570	104
30 Nosler	210		Crusher Pressures Not Established		
30 Remington AR	125		Crusher Pressures Not Established		
30 Thompson Center	150		Crusher Pressures Not Established		
30-06 Springfield	220	500	670	715	129
30-30 Winchester	170	380	510	545	99
30-40 Krag	180	400	535	570	104
300 AAC Blackout	220		Crusher Pressures Not Established		
300 Holland & Holland Magnum	180	540	725	775	140
300 Remington Short Action Ultra Magnum	180		Crusher Pressures Not Established		
300 Remington Ultra Magnum	200		Crusher Pressures Not Established		
300 Ruger Compact Magnum	180		Crusher Pressures Not Established		
300 Savage	180	460	615	660	119
300 Weatherby Magnum	220		Crusher Pressures Not Established		
300 Winchester Magnum	220	540	725	775	140
300 Winchester Short Magnum	180		Crusher Pressures Not Established		
303 British	180	450	600	645	117
307 Winchester	150	520	695	745	135
308 Marlin Express	160		Crusher Pressures Not Established		
308 Winchester	180	520	695	745	135

⁽¹⁾ Based on sample size $\eta=10$.

PROOF PRESSURE DATA - CRUSHER (Continued)

Cartridge	Bullet Weight (graiins)	SERVICE Maximum Average Pressure (CUP/100)	Pressure Values of Proof Cartridges ⁽¹⁾		
			Minimum Average (CUP/100)	Maximum Average (CUP/100)	Maximum E.V. (CUP/100)
32 Winchester Special	170	380	510	545	99
32-20 Winchester	100	160	215	225	42
325 Winchester Short Magnum	220	Crusher Pressures Not Established			
33 Nosler	250	Crusher Pressures Not Established			
338 Federal	210	Crusher Pressures Not Established			
338 Lapua Magnum	250	Crusher Pressures Not Established			
338 Marlin Express	200	Crusher Pressures Not Established			
338 Remington Ultra Magnum	250	Crusher Pressures Not Established			
338 Ruger Compact Magnum	225	Crusher Pressures Not Established			
338 Winchester Magnum	250	540	725	775	140
340 Weatherby Magnum	250	535	715	765	139
348 Winchester	200	400	535	570	104
35 Nosler	225	Crusher Pressures Not Established			
35 Remington	200	350	470	500	91
35 Whelen	250	520	695	745	135
350 Remington Magnum	250	530	710	760	137
356 Winchester	250	520	695	745	135
358 Winchester	200	520	695	745	135
36 Nosler	250	Crusher Pressures Not Established			
370 Sako Magnum	286	Crusher Pressures Not Established			
375 Holland & Holland Magnum	300	530	710	760	137
375 Remington Ultra Magnum	300	Crusher Pressures Not Established			
375 Ruger	300	Crusher Pressures Not Established			
375 Winchester	250	520	695	745	135
376 Steyr	270	Crusher Pressures Not Established			
38-40 Winchester	180	140	190	200	37
38-55 Winchester	255	300	405	430	78

⁽¹⁾ Based on sample size $\eta=10$.

PROOF PRESSURE DATA - CRUSHER (Continued)

Cartridge	Bullet Weight (grains)	SERVICE Maximum Average Pressure (CUP/100)	Pressure Values of Proof Cartridges ⁽¹⁾		
			Minimum Average (CUP/100)	Maximum Average (CUP/100)	Maximum E.V. (CUP/100)
405 Winchester	300		Crusher Pressures Not Established		
416 Remington Magnum	400	540	725	775	140
416 Rigby			Crusher Pressures Not Established		
416 Ruger	400		Crusher Pressures Not Established		
416 Weatherby Magnum	400	535	715	765	139
44 Remington Magnum	240	400	535	570	104
44-40 Winchester	200	130	175	185	34
444 Marlin	240	440	590	630	114
45-70 Government	405	280	375	400	73
450 Bushmaster	250		Crusher Pressures Not Established		
450 Marlin	350		Crusher Pressures Not Established		
457 Wild West Guns	435		Crusher Pressures Not Established		
458 Lott	465		Crusher Pressures Not Established		
458 Winchester Magnum	510	530	710	760	137
470 Nitro Express	500	350	470	500	91
475 Turnbull	500		Crusher Pressures Not Established		
500 Nitro Express 3"	570		Crusher Pressures Not Established		

⁽¹⁾ Based on sample size $n=10$.

PROOF PRESSURE DATA - TRANSDUCER

Cartridge	Bullet Weight (grains)	SERVICE Maximum Average Pressure (psi/100)	Pressure Values of Proof Cartridges ⁽¹⁾		
			Minimum Average (psi/100)	Maximum Average (psi/100)	Maximum E.V. (psi/100)
6 x 45mm	80	550	735	785	142
6mm Remington	100	650	870	930	168
6.5 Creedmoor	140	620	830	890	160
6.5 Grendel	123	520	695	745	135
6.5 x 55 Swedish	140	510	680	730	132
6.8mm Remington SPC	115	550	735	785	142
7mm Mauser (7x57)	175	510	680	730	132
7mm Remington Magnum	175	610	815	875	158
7mm Remington Short Action Ultra Magnum		650	870	930	168
7mm Remington Ultra Magnum		650	870	930	168
7mm Shooting Times Westerner		650	870	930	168
7mm Weatherby Magnum		650	870	930	168
7mm Winchester Short Magnum		650	870	930	168
7mm-08 Remington	140	610	815	875	158
7 x 64 Brenneke	175	Transducer Pressures Not Established			
7-30 Waters	120	450	600	645	117
7.62 x 39	123	450	600	645	117
8mm Mauser (8x57)	170	350	470	500	91
8mm Remington Magnum	220	650	870	930	168
9.3 x 62	220	575	770	825	149
17 Hornet	20	500	670	715	129
17 Remington	25	630	840	900	163
17 Remington Fireball	20	550	735	785	142
204 Ruger	32	575	770	825	149
218 Bee	46	Transducer Pressures Not Established			
22 Hornet	45	490	655	700	127
22-250 Remington	55	650	870	930	168
220 Swift	60	620	830	890	160
221 Remington Fireball	50	Transducer Pressures Not Established			
222 Remington	55	500	670	715	129
222 Remington Magnum	55	550	735	785	142
223 Remington	64	550	735	785	142
223 Winchester Super Short Magnum		650	870	930	168

⁽¹⁾ Based on sample size $n=10$.

PROOF PRESSURE DATA - TRANSDUCER (Continued)

Cartridge	Bullet Weight (grains)	SERVICE Maximum Average Pressure (psi/100)	Pressure Values of Proof Cartridges ⁽¹⁾		
			Minimum Average (psi/100)	Maximum Average (psi/100)	Maximum E.V. (psi/100)
225 Winchester	55	Transducer Pressures Not Established			
243 Winchester	100	600	800	860	155
243 Winchester Super Short Magnum	100	650	870	930	168
25 Winchester Super Short Magnum	85	650	870	930	168
25-06 Remington	120	630	840	900	163
25-20 Winchester	86	Transducer Pressures Not Established			
25-35 Winchester	117	Transducer Pressures Not Established			
250 Savage	100	Transducer Pressures Not Established			
257 Roberts		Obsolete – Use 257 Roberts +P Only			
257 Roberts +P	117	580	775	830	150
257 Weatherby Magnum	120	625	835	895	162
26 Nosler	129	650	870	930	168
260 Remington	120	600	800	860	155
264 Winchester Magnum	140	640	855	915	166
27 Nosler	150	650	870	930	168
270 Weatherby Magnum	150	625	835	895	162
270 Winchester	150	650	870	930	168
270 Winchester Short Magnum	150	650	870	930	168
28 Nosler	168	650	870	930	168
280 Ackley Improved	140	650	870	930	168
280 Remington	165	600	800	860	155
284 Winchester	150	560	750	800	145
30 Carbine	110	400	535	570	104
30 Nosler	210	650	870	930	168
30 Remington AR	125	550	735	785	142
30 Thompson Center	150	620	830	890	160
30-06 Springfield	220	600	800	860	155
30-30 Winchester	170	420	565	600	109
30-40 Krag	180	Transducer Pressures Not Established			
300 AAC Blackout	220	550	735	785	142
300 Holland & Holland Magnum	180	580	775	830	150
300 Remington Short Action Ultra Magnum	180	650	870	930	168
300 Remington Ultra Magnum	200	650	870	930	168
300 Ruger Compact Magnum	180	650	870	930	168
300 Savage	180	470	630	670	122
300 Weatherby Magnum	220	650	870	930	168
300 Winchester Magnum	220	640	855	915	166
300 Winchester Short Magnum	180	650	870	930	168
303 British	180	490	655	700	127

⁽¹⁾ Based on sample size $n=10$.

PROOF PRESSURE DATA - TRANSDUCER (Continued)

Cartridge	Bullet Weight (grains)	SERVICE Maximum Average Pressure (psi/100)	Pressure Values of Proof Cartridges ⁽¹⁾		
			Minimum Average (psi/100)	Maximum Average (psi/100)	Maximum E.V. (psi/100)
307 Winchester	150	Transducer Pressures Not Established			
308 Marlin Express	160	475	635	680	123
308 Winchester	180	620	830	890	160
32 Winchester Special	170	420	565	600	109
32-20 Winchester	100	Transducer Pressures Not Established			
325 Winchester Short Magnum	220	650	870	930	168
33 Nosler	250	650	870	930	168
338 Federal	210	620	830	890	160
338 Lapua Magnum	250	650	870	930	168
338 Marlin Express	200	460	615	660	119
338 Remington Ultra Magnum	250	650	870	930	168
338 Ruger Compact Magnum	225	650	870	930	168
338 Winchester Magnum	250	640	855	915	166
340 Weatherby Magnum	250	625	835	895	162
348 Winchester	200	Transducer Pressures Not Established			
35 Nosler	225	650	870	930	168
35 Remington	200	335	450	480	87
35 Whelen	250	620	830	890	160
350 Remington Magnum	250	Transducer Pressures Not Established			
356 Winchester	250	Transducer Pressures Not Established			
358 Winchester	200	Transducer Pressures Not Established			
36 Nosler	250	650	870	930	168
370 Sako Magnum	286	600	800	860	155
375 Holland & Holland Magnum	300	620	830	890	160
375 Remington Ultra Magnum	300	650	870	930	168
375 Ruger	300	620	830	890	160
375 Winchester	250	Transducer Pressures Not Established			
376 Steyr	270	620	830	890	160
38-40 Winchester	180	Transducer Pressures Not Established			
38-55 Winchester	255	Transducer Pressures Not Established			

⁽¹⁾ Based on sample size $n=10$.

PROOF PRESSURE DATA - TRANSDUCER (Continued)

Cartridge	Bullet Weight (grains)	SERVICE Maximum Average Pressure (psi/100)	Pressure Values of Proof Cartridges⁽¹⁾		
			Minimum Average (psi/100)	Maximum Average (psi/100)	Maximum E.V. (psi/100)
405 Winchester	300	460	615	660	119
416 Remington Magnum	400	650	870	930	168
416 Rigby		520	695	745	135
416 Ruger	400	620	830	890	160
416 Weatherby Magnum	400	Transducer Pressures Not Established			
44 Remington Magnum	240	360	480	515	93
44-40 Winchester	200	110	150	155	29
444 Marlin	240	420	565	600	109
45-70 Government	405	280	375	400	73
450 Bushmaster	250	385	515	550	100
450 Marlin	350	435	580	620	113
457 Wild West Guns	325	435	580	620	113
458 Lott	465	625	835	895	162
458 Winchester Magnum	510	600	800	860	155
470 Nitro Express	500	410	550	585	106
475 Turnbull	500	420	565	600	109
500 Nitro Express 3"	570	385	515	550	100

⁽¹⁾ Based on sample size $n=10$.

PROOF LOAD SUPPLY

NOTE: Refer to Section III – page 223, *Supplier Contact Information*, for detailed information on contacting the manufacturers of listed products and the SAAMI Technical Office.

Centerfire rifle Definitive Proof Loads should be used for one purpose only: the proof testing of Centerfire rifles.

A list of current suppliers may be obtained from the SAAMI Technical Office.

PROOF CARTRIDGE IDENTIFICATION

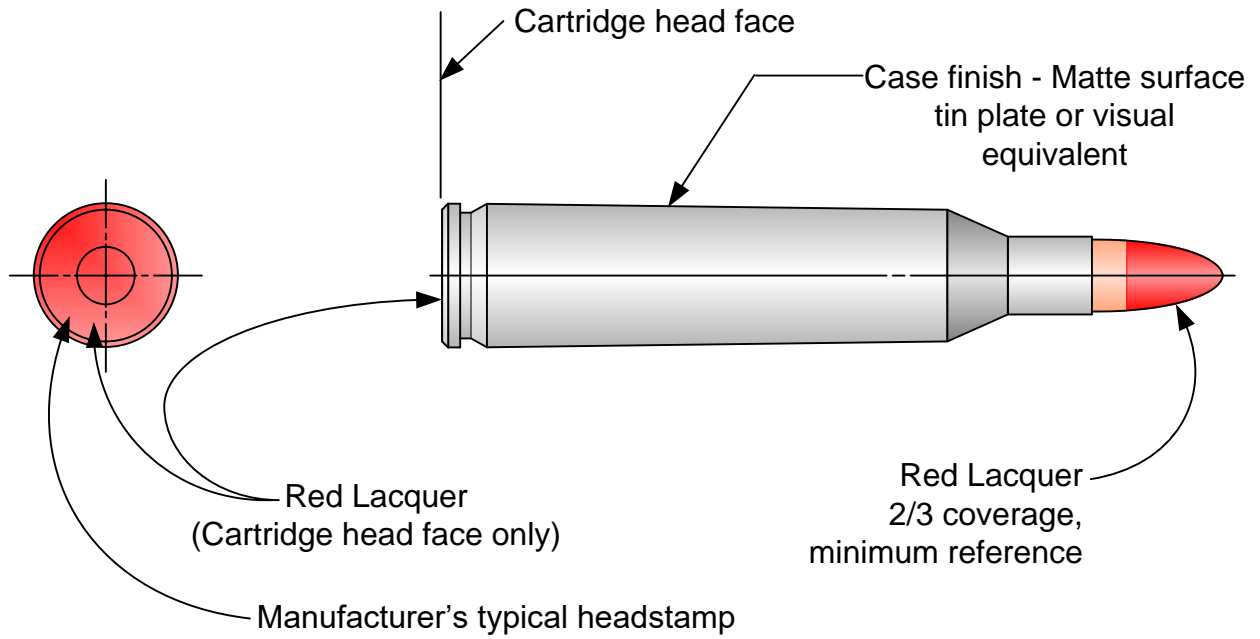

DEFINITIVE PROOF PACKAGE IDENTIFICATION

HIGH PRESSURE PROOF LOADS

For Gun Manufacturers' Proof Test Use Only: Fire only from fixed rest with operator properly protected from injury should the firearm be damaged. Purchaser should restrict proof loads to manufacturing premises. To dispose of proof loads, contact producer for instructions.

DO NOT reload or dispose of fired proof shells in a manner that may make them available for reloading. **Failure to follow the foregoing can result in a personal injury.**

Centerfire proof loads are identified by a tin-plated case (or visual equivalent) with red lacquer on the bullet and case head face.

For consistent results, proof loads should be stored for 2 weeks at $70^{\circ}\text{F} \pm 5^{\circ}$ ($21.1^{\circ} \pm 2.8^{\circ}\text{C}$), and 60% relative humidity before use.

"WARNING: KEEP OUT OF REACH OF CHILDREN"

(Red lettering on white background)