



# High Voltage Direct Current Transmission –

Proven Technology for Power Exchange

Answers for energy.

**SIEMENS**



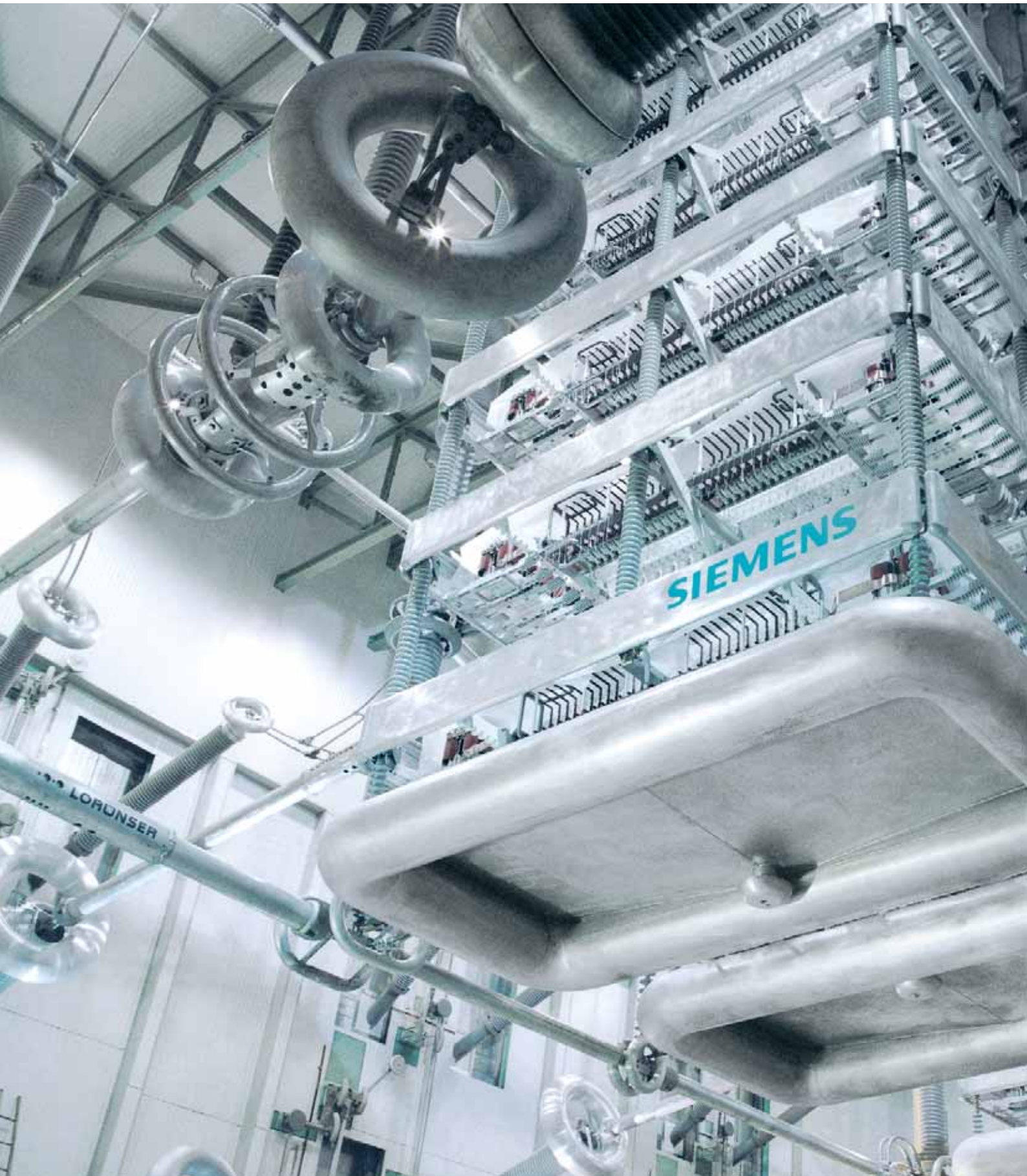



# Contents



Chapter	Theme	Page
1	Why High Voltage Direct Current?	4
2	Main Types of HVDC Schemes	6
3	Converter Theory	8
4	Principle Arrangement of an HVDC Transmission Project	11
5	Main Components	14
5.1	Thyristor Valves	15
5.2	Converter Transformer	18
5.3	Smoothing Reactor	21
5.4	Harmonic Filters	22
5.4.1	AC Harmonic Filter	23
5.4.2	DC Harmonic Filter	25
5.4.3	Active Harmonic Filter	26
5.5	Surge Arrester	28
5.6	DC Transmission Circuit	31
5.6.1	DC Transmission Line	31
5.6.2	DC Cable	33
5.6.3	High Speed DC Switches	34
5.6.4	Earth Electrode	36
5.7	Control & Protection	38
6	System Studies, Digital Models, Design Specifications	45
7	Project Management	46

# 1 Why High Voltage Direct Current ?

## 1.1 Highlights from the High Voltage Direct Current (HVDC) History

*The transmission and distribution of electrical energy started with direct current. In 1882, a 50-km-long 2-kV DC transmission line was built between Miesbach and Munich in Germany. At that time, conversion between reasonable consumer voltages and higher DC transmission voltages could only be realized by means of rotating DC machines.*

In an AC system, voltage conversion is simple. An AC transformer allows high power levels and high insulation levels within one unit, and has low losses. It is a relatively simple device, which requires little maintenance. Further, a three-phase synchronous generator is superior to a DC generator in every respect. For these reasons, AC technology was introduced at a very early stage in the development of electrical power systems. It was soon accepted as the only feasible technology for generation, transmission and distribution of electrical energy.

However, high-voltage AC transmission links have disadvantages, which may compel a change to DC technology:

- Inductive and capacitive elements of overhead lines and cables put limits to the transmission capacity and the transmission distance of AC transmission links.
- This limitation is of particular significance for cables. Depending on the required transmission capacity, the system frequency and the loss evaluation, the achievable transmission distance for an AC cable will be in the range of 40 to 100 km. It will mainly be limited by the charging current.
- Direct connection between two AC systems with different frequencies is not possible.
- Direct connection between two AC systems with the same frequency or a new connection within a meshed grid may be impossible because of system instability, too high short-circuit levels or undesirable power flow scenarios.

Engineers were therefore engaged over generations in the development of a technology for DC transmissions as a supplement to the AC transmissions.

## Line-Commutated Current Sourced Converters

The invention of mercury arc rectifiers in the nineteen-thirties made the design of line-commutated current sourced converters possible.

*In 1941, the first contract for a commercial HVDC system was signed in Germany: 60 MW were to be supplied to the city of Berlin via an underground cable of 115 km length. The system with  $\pm 200$  kV and 150 A was ready for energizing in 1945. It was never put into operation.*

Since then, several large HVDC systems have been realized with mercury arc valves.

The replacement of mercury arc valves by thyristor valves was the next major development. The first thyristor valves were put into operation in the late nineteen-seventies.

The outdoor valves for Cahora Bassa were designed with oil-immersed thyristors with parallel/series connection of thyristors and an electromagnetic firing system.

Further development went via air-insulated air-cooled valves to the air-insulated water-cooled design, which is still state of the art in HVDC valve design.

The development of thyristors with higher current and voltage ratings has eliminated the need for parallel connection and reduced the number of series-connected thyristors per valve. The development of light-triggered thyristors has further reduced the overall number of components and thus contributed to increased reliability.

Innovations in almost every other area of HVDC have been constantly adding to the reliability of this technology with economic benefits for users throughout the world.

## Self-Commutated Voltage Sourced Converters

Voltage sourced converters require semiconductor devices with turn-off capability. The development of Insulated Gate Bipolar Transistors (IGBT) with high voltage ratings have accelerated the development of voltage sourced converters for HVDC applications in the lower power range.

The main characteristics of the voltage sourced converters are a compact design, four-quadrant operation capability and high losses.

Siemens is offering voltage sourced converters for HVDC applications with ratings up to 250 MW under the trade name HVDC<sup>plus</sup> Power Link Universal Systems.

This paper focuses upon HVDC transmission systems with high ratings, i.e. with line-commutated current sourced converters.

HVDC = high voltage direct current  
DC = direct current  
AC = alternating current  
IGBT = insulated gate bipolar transistor

## 1.2 Technical Merits of HVDC

The advantages of a DC link over an AC link are:

- A DC link allows power transmission between AC networks with different frequencies or networks, which can not be synchronized, for other reasons.
- Inductive and capacitive parameters do not limit the transmission capacity or the maximum length of a DC overhead line or cable. The conductor cross section is fully utilized because there is no skin effect.

For a long cable connection, e.g. beyond 40 km, HVDC will in most cases offer the only technical solution because of the high charging current of an AC cable. This is of particular interest for transmission across open sea or into large cities where a DC cable may provide the only possible solution.

- A digital control system provides accurate and fast control of the active power flow.
- Fast modulation of DC transmission power can be used to damp power oscillations in an AC grid and thus improve the system stability.

## 1.3 Economic Considerations

For a given transmission task, feasibility studies are carried out before the final decision on implementation of an HVAC or HVDC system can be taken. Fig. 1-1 shows a typical cost comparison curve between AC and DC transmission considering:

- AC vs. DC station terminal costs
- AC vs. DC line costs
- AC vs. DC capitalised value of losses

The DC curve is not as steep as the AC curve because of considerably lower line costs per kilometre. For long AC lines the cost of intermediate reactive power compensation has to be taken into account.

The break-even distance is in the range of 500 to 800 km depending on a number of other factors, like country-specific cost elements, interest rates for project financing, loss evaluation, cost of right of way etc.

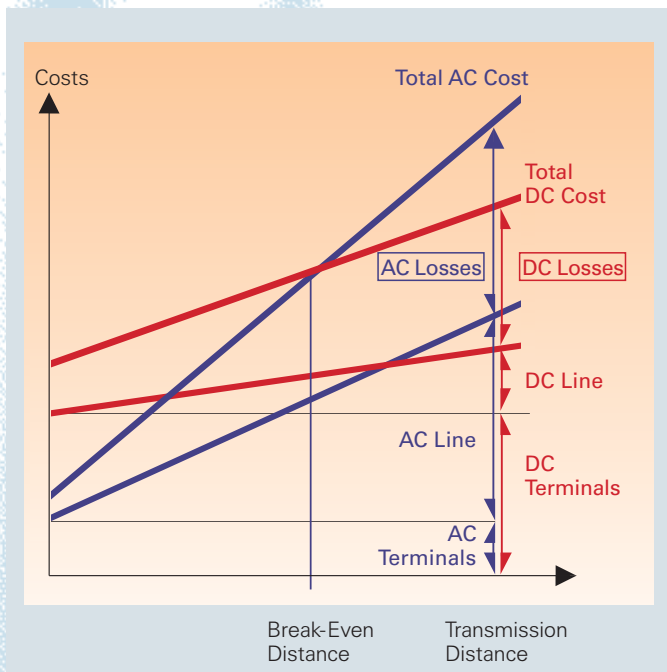

Fig. 1-1: Total cost/distance

## 1.4 Environmental Issues

An HVDC transmission system is basically environment-friendly because improved energy transmission possibilities contribute to a more efficient utilization of existing power plants.

The land coverage and the associated right-of-way cost for an HVDC overhead transmission line is not as high as that of an AC line. This reduces the visual impact and saves land compensation for new projects. It is also possible to increase the power transmission capacity for existing rights of way. A comparison between a DC and an AC overhead line is shown in Fig. 1-2.

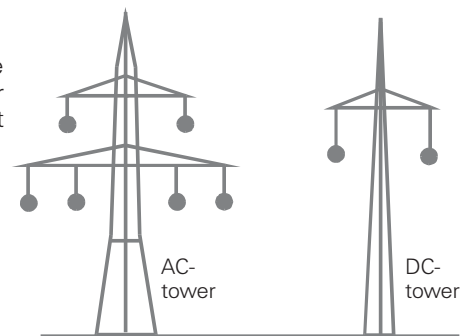

Fig. 1-2: Typical transmission line structures for approx. 1000 MW

There are, however, some environmental issues which must be considered for the converter stations. The most important ones are:

- Audible noise
- Visual impact
- Electromagnetic compatibility
- Use of ground or sea return path in monopolar operation

In general, it can be said that an HVDC system is highly compatible with any environment and can be integrated into it without the need to compromise on any environmentally important issues of today.



# 2 Main Types of HVDC Schemes

## 2.1 DC Circuit

The main types of HVDC converters are distinguished by their DC circuit arrangements. The following equivalent circuit is a simplified representation of the DC circuit of an HVDC pole.

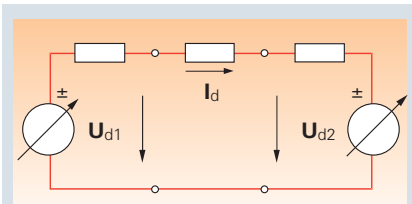

Fig. 2-1: Equivalent DC circuit

The current, and thus the power flow, is controlled by means of the difference between the controlled voltages. The current direction is fixed and the power direction is controlled by means of the voltage polarity. The converter is described in the next section.

## 2.2 Back-to-Back Converters

The expression Back-to-back indicates that the rectifier and inverter are located in the same station.

Back-to-back converters are mainly used for power transmission between adjacent AC grids which can not be synchronized. They can also be used within a meshed grid in order to achieve a defined power flow.

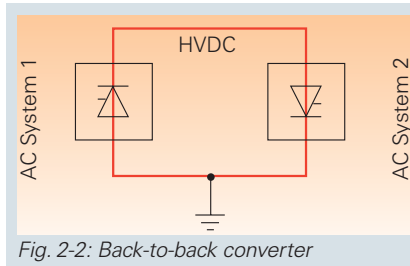

Fig. 2-2: Back-to-back converter

## 2.3 Monopolar Long-Distance Transmissions

For very long distances and in particular for very long sea cable transmissions, a return path with ground/sea electrodes will be the most feasible solution.

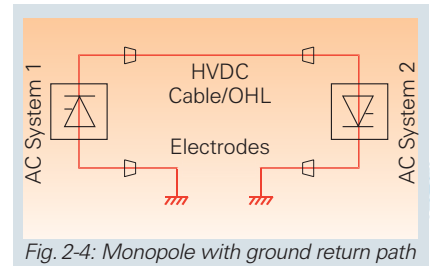

Fig. 2-4: Monopole with ground return path

In many cases, existing infrastructure or environmental constraints prevent the use of electrodes. In such cases, a metallic return path is used in spite of increased cost and losses.

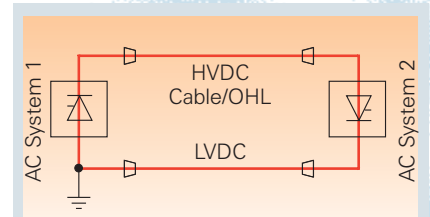

Fig. 2-5: Monopole with metallic return path



Fig. 2-3: Back-to-back converter Station Vienna Southeast

- HVDC = high voltage direct current
- DC = direct current
- AC = alternating current
- $U_d$  = DC voltage 12-pulse
- $I_d$  = DC current
- OHL = overhead line
- LVDC = low voltage direct current

## 2.4 Bipolar Long-Distance Transmissions

A bipole is a combination of two poles in such a way that a common low voltage return path, if available, will only carry a small unbalance current during normal operation.

This configuration is used if the required transmission capacity exceeds that of a single pole. It is also used if requirement to higher energy availability or lower load rejection power makes it necessary to split the capacity on two poles.

During maintenance or outages of one pole, it is still possible to transmit part of the power. More than 50% of the transmission capacity can be utilized, limited by the actual overload capacity of the remaining pole.

The advantages of a bipolar solution over a solution with two monopoles are reduced cost due to one common or no return path and lower losses. The main disadvantage is that unavailability of the return path with adjacent components will affect both poles.

### 2.4.1 Bipole with Ground Return Path

This is a commonly used configuration for a bipolar transmission system. The solution provides a high degree of flexibility with respect to operation with reduced capacity during contingencies or maintenance.

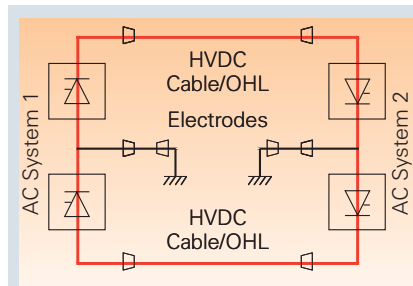

Fig. 2-6: in bipolar balanced operation (normal)

Upon a single-pole fault, the current of the sound pole will be taken over by the ground return path and the faulty pole will be isolated.

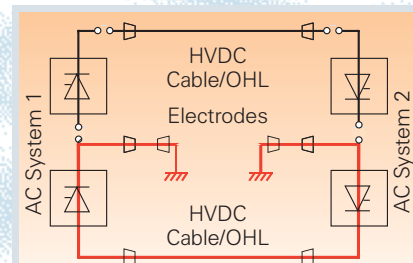

Fig. 2-7: in monopolar ground return operation (converter pole or OHL outage)

Following a pole outage caused by the converter, the current can be commutated from the ground return path into a metallic return path provided by the HVDC conductor of the faulty pole.

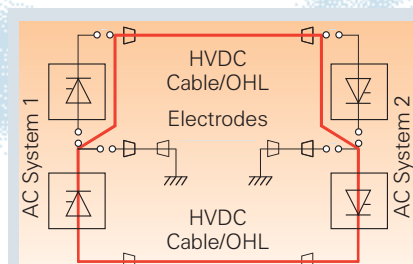

Fig. 2-8: in monopolar metallic return operation (converter pole outage)

### 2.4.2 Bipole with Dedicated Metallic Return Path for Monopolar Operation

If there are restrictions even to temporary use of electrodes, or if the transmission distance is relatively short, a dedicated LVDC metallic return conductor can be considered as an alternative to a ground return path with electrodes.

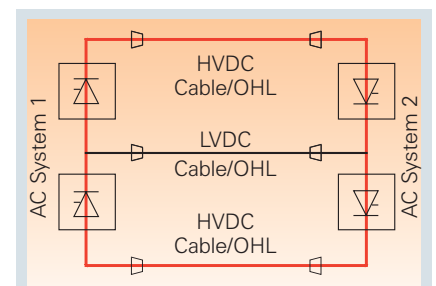

Fig. 2-9: in bipolar balanced operation (normal)

### 2.4.3 Bipole without Dedicated Return Path for Monopolar Operation

A scheme without electrodes or a dedicated metallic return path for monopolar operation will give the lowest initial cost.

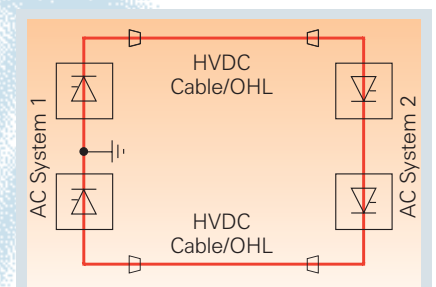

Fig. 2-10: in bipolar balanced operation (normal)

Monopolar operation is possible by means of bypass switches during a converter pole outage, but not during an HVDC conductor outage.

A short bipolar outage will follow a converter pole outage before the bypass operation can be established.

### 3.1 Bridge Circuit Function

Current flows through the valves when the voltage between the anode and cathode is positive. For the valve to commutate the current, there must be a positive potential (voltage), and the thyristor must have firing pulses. In the reverse direction, i.e. when the potential between anode and cathode is negative, a firing pulse has no effect. The flow of current in a valve ends when the voltage between anode and cathode becomes negative. The instant when current begins to flow through a valve, or to commutate from one valve to another, can be delayed by postponing the firing. This method permits the average value of the outgoing voltage of the rectifier to be changed. The firing pulses are generated by synchronizing the network using an electronic control device. These pulses can be displaced from their "natural firing" point, which is the point where the two phase voltages intersect. The method of firing-pulse displacement is called phase control.

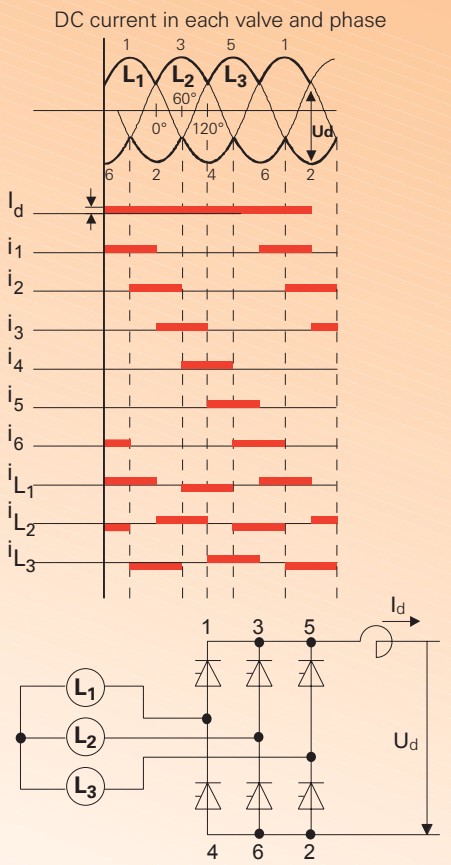

Fig. 3-1: Six-pulse converter bridge

The angle between the time at which the valve voltage becomes positive and the firing time (start of commutation) is referred to as the firing delay. Fig. 3-2 shows that for a firing delay of  $90^\circ$ , the average voltage equals zero. i.e. the positive and negative areas of the curve – voltage against time – cancel each other out. No active power flows through the converter.

When the firing delay is greater than  $90^\circ$ , the negative voltage/time areas dominate, and the polarity of the average direct voltage changes. Due to physical reasons, the direction of the current does not change. (The thyristor valves conduct current only in one direction.) When the direction of energy flow is reversed, the delivery changes to the supply side. The rectifier becomes an inverter which delivers energy to the AC network.

The average value of the direct voltage as a function of the firing delay is given by:

$$U_{di\alpha} = 1.35 * U_L * \cos \alpha$$

$U_L$  = secondary side line voltage  
 $\alpha$  = firing angle  
 $\gamma$  = extinction angle

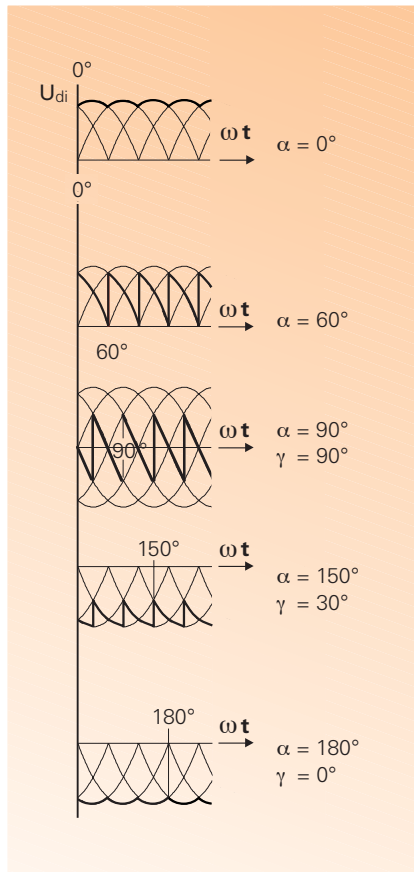

Fig. 3-2: DC voltage of bridge converter as a function of  $\alpha$

### 3.2 12-Pulse Group and Converter Transformer

HVDC converters are usually built as 12-pulse circuits. This is a serial connection of two fully controlled 6-pulse converter bridges and requires two 3-phase systems which are spaced apart from each other by 30 electrical degrees. The phase difference effected to cancel out the 6-pulse harmonics on the AC and DC side.

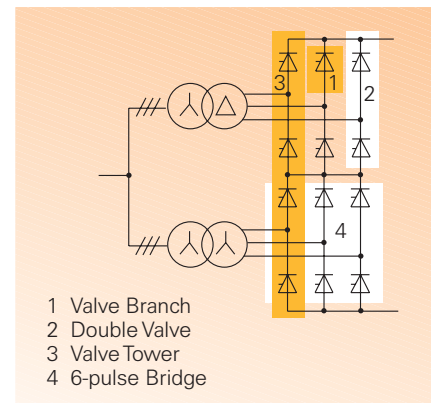

Fig. 3-3: Arrangement of the valve branches in a 12-pulse bridge



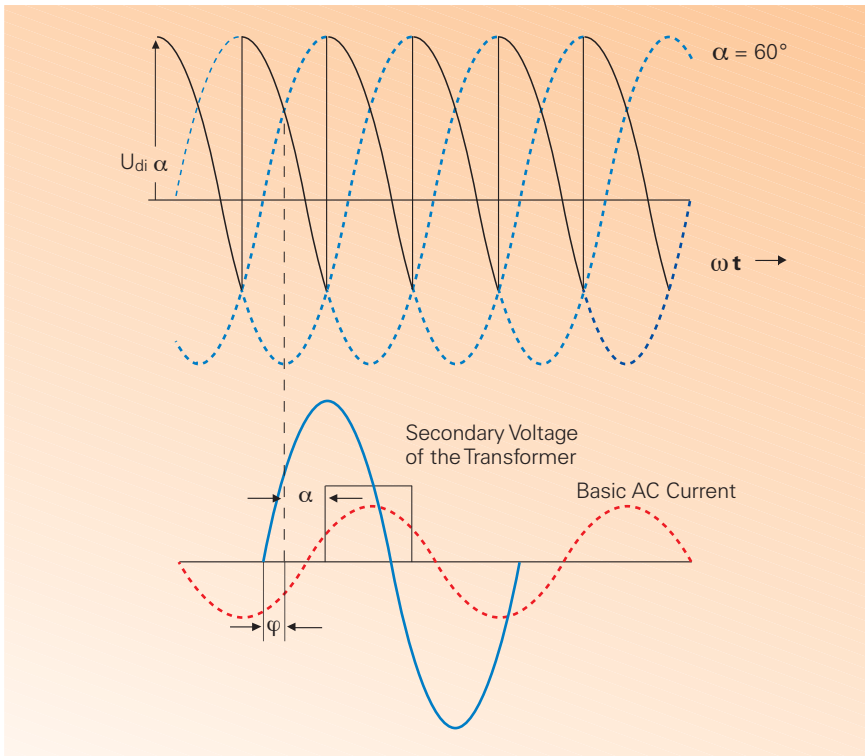

Fig. 3-4:  
Current displacement with angle control

#### HVDC DC Circuit

$$U_{dN} = P_{dN \text{ Rec}} / I_{dN}$$

$U_{dN}$  => nominal DC voltage 12-pulse

$I_{dN}$  => nominal DC current

$P_{dN \text{ Rec}}$  => nominal DC active power at the rectifier

- $d_x$  = relative inductive voltage drop
- $U_v$  = valve voltage
- $U_d$  = DC voltage 12-pulse
- $\alpha$  = firing angle
- $\beta$  =  $180^\circ - \alpha$
- $\gamma$  = extinction angle

### 3.3 Reactive Power as a Function of Load

The curve of reactive power demand of an HVDC station with changing active power  $P$  can be calculated from equation:

$$Q = P * \tan [ \text{arc cos} ( \cos \alpha - d_x ) ]$$

In Fig. 3-5, the reactive power demand of a converter is presented under three different control methods.

If the terminal DC voltage  $U_d$  and the firing angle  $\alpha$  (or the extinction angle  $\gamma$  of an inverter) are held constant, curve (1) will be obtained. If, however,  $U_v$  is held constant ( $U_{di} = \text{const}$  regulation), a linear curve such as (2) is obtained. The power of a converter can also be changed when the (nominal) current is held constant by varying the DC voltage. Curve (3) shows the reactive power demand for this control method. It is important to note that the entire area between curves (1) and (3) is available for reactive power control. Each point within this area can be set by the selection of firing angles  $\alpha$  and  $\beta$  (or  $\gamma$ ).

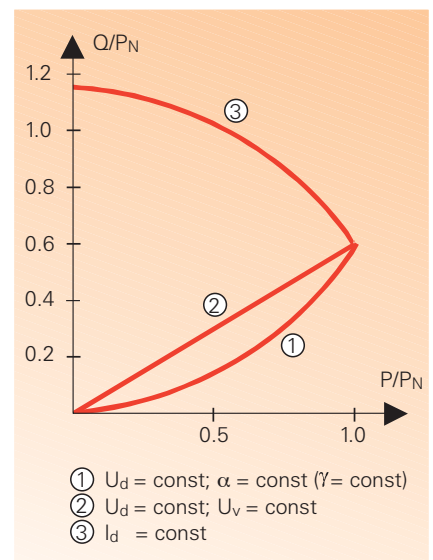

Fig. 3-5:  
Reactive power demand of an HVDC converter

## 3.4 Reactive Power Control

The possibility of electronic reactive power control as demonstrated in the preceding section is used only to a very limited degree in HVDC technology. This is due to economic reasons. Both control reactive power and commutation reactive power are increased by the reduction of the DC voltage and the corresponding increase of current. However, load losses increase with the square of the current. For this reason, application is limited to the light loads where the necessary filter circuits produce a considerable overcompensation for the reactive power required by the converter.

Fig. 3-6 depicts the reactive power control of the Dürnrohr HVDC link. In this system, a compensation to  $\pm 60$  Mvar was specified. Compliance with the Q limit is achieved by load-dependent switching of a capacitor bank and one of the two high-pass filters. Electronic reactive power is used only in the light load range. Normally, there is a difference between the connect and disconnect points of the reactive power elements. This provides a "switching hysteresis" which prevents too many switching operations or even a "pumping".

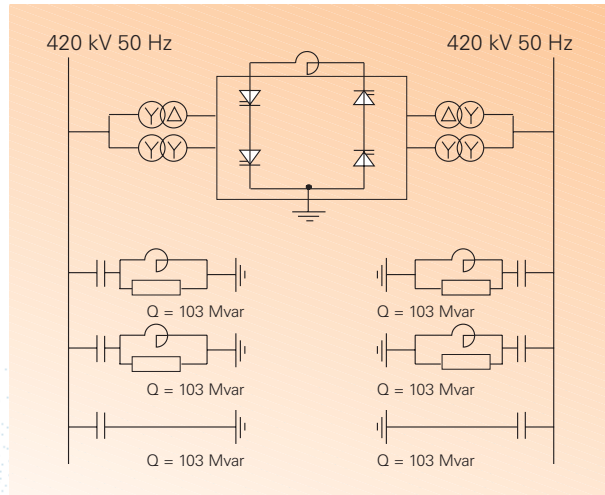
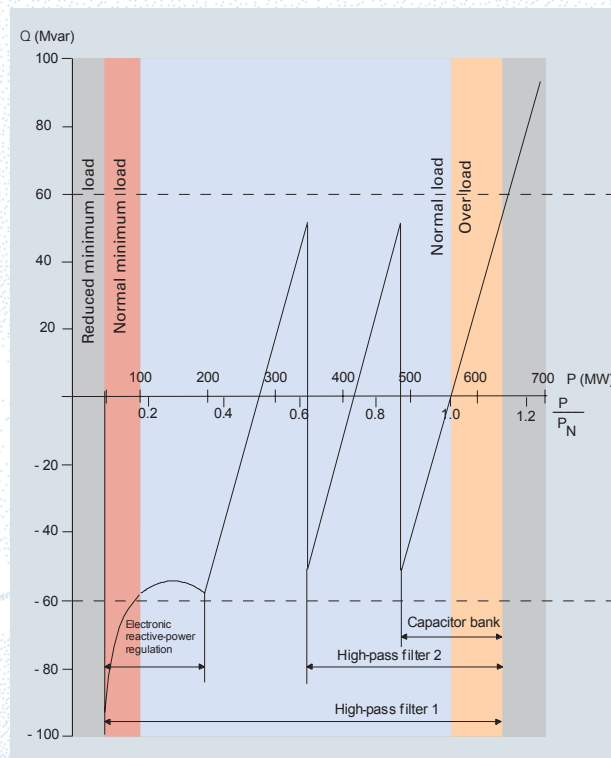

Fig. 3-6: Reactive-power compensation and control of an HVDC back-to-back link



### Reactive-Power Balance

$U_{AC}$  in p.u. (AC bus voltage)

- cap. reactive-power reactive-power reactive-power reactive-power  
 + ind. converter AC filters reactors capacitors

$$Q_{Network} = + Q_{Conv} - Q_{FK} \cdot U_{AC}^2 + Q_L \cdot U_{AC}^2 - Q_C \cdot U_{AC}^2$$





The Principle Arrangement of an HVDC Transmission Project is reflected on the Moyle Interconnector project. The HVDC stations between Northern Ireland and Scotland are operating with the following highlights:

- Direct light triggered thyristor valves for the complete HVDC system, with 1872 thyristors in total, with 20% better reliability and all valve components free from oil.
- Triple tuned AC filter in both stations.
- Unmanned stations, fully automatic remote operation and automatic load schedule operation.
- Hybrid optical ohmic shunt for DC current measuring unit.
- Low noise station design for:
  - AC filter capacitor and reactors
  - converter transformer
  - converter valve water cooling system
  - DC hall with smoothing reactor
- Station design for DC sea/land cable with integrated return conductor and fibre optic cable for control and communication.

Date of contract	09/99
Delivery period	27 months

System Data	
Transmission capacity	2 x 250 MW
System voltages	250 kV DC 275 kV AC
Rated current	1000 A
Transmission distance	63.5 km

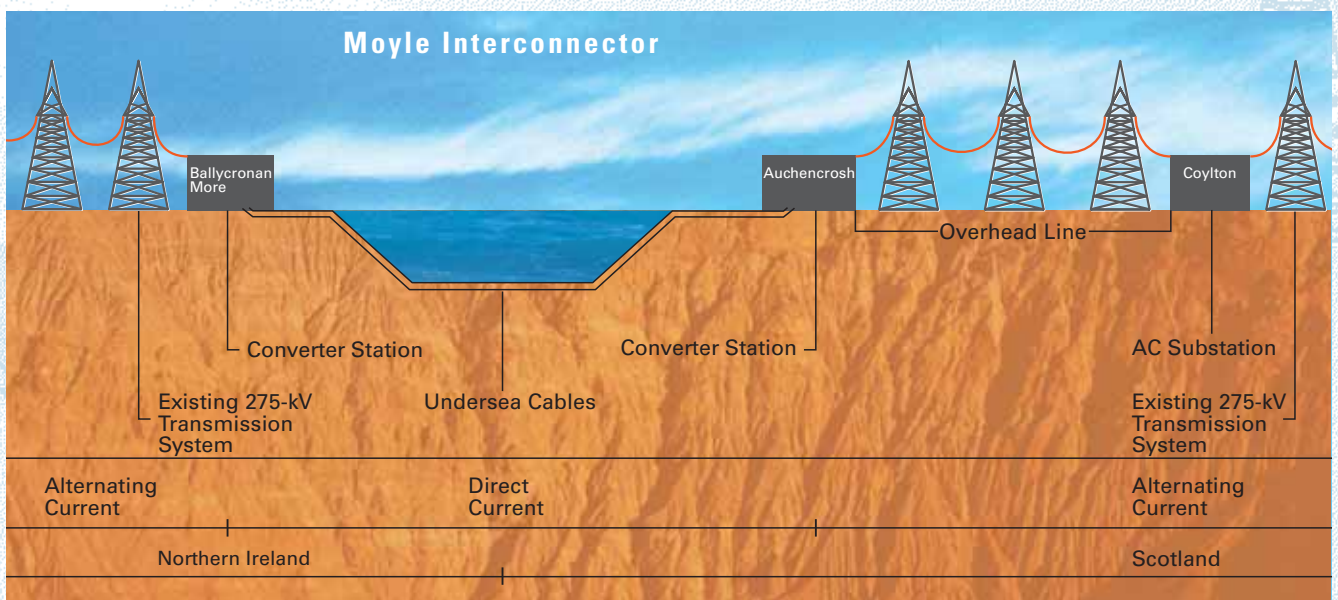



# Principle Arrangement of an HVDC Transmission Project

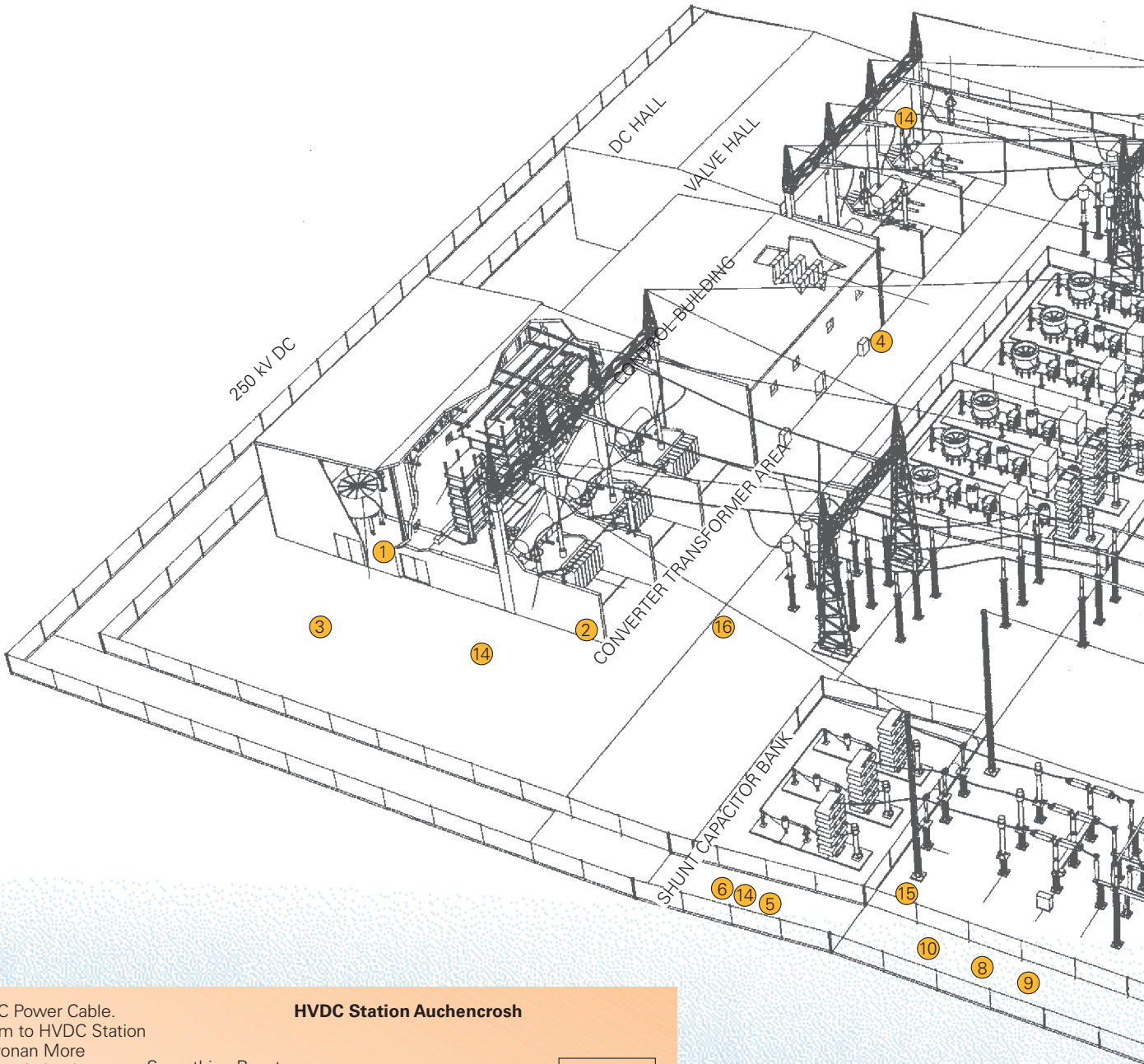

250 DC Power Cable.  
63,5 km to HVDC Station  
Ballycronan More  
Northern Ireland

**HVDC Station Auchencrosh**

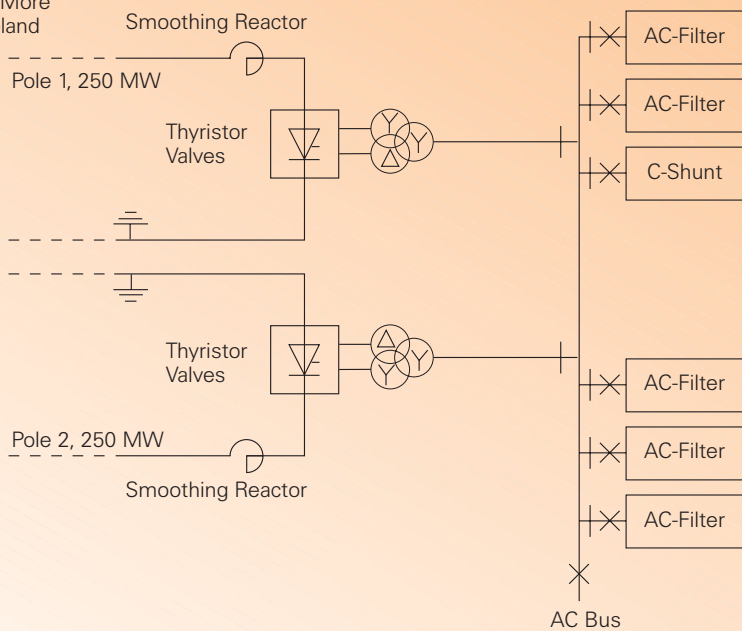



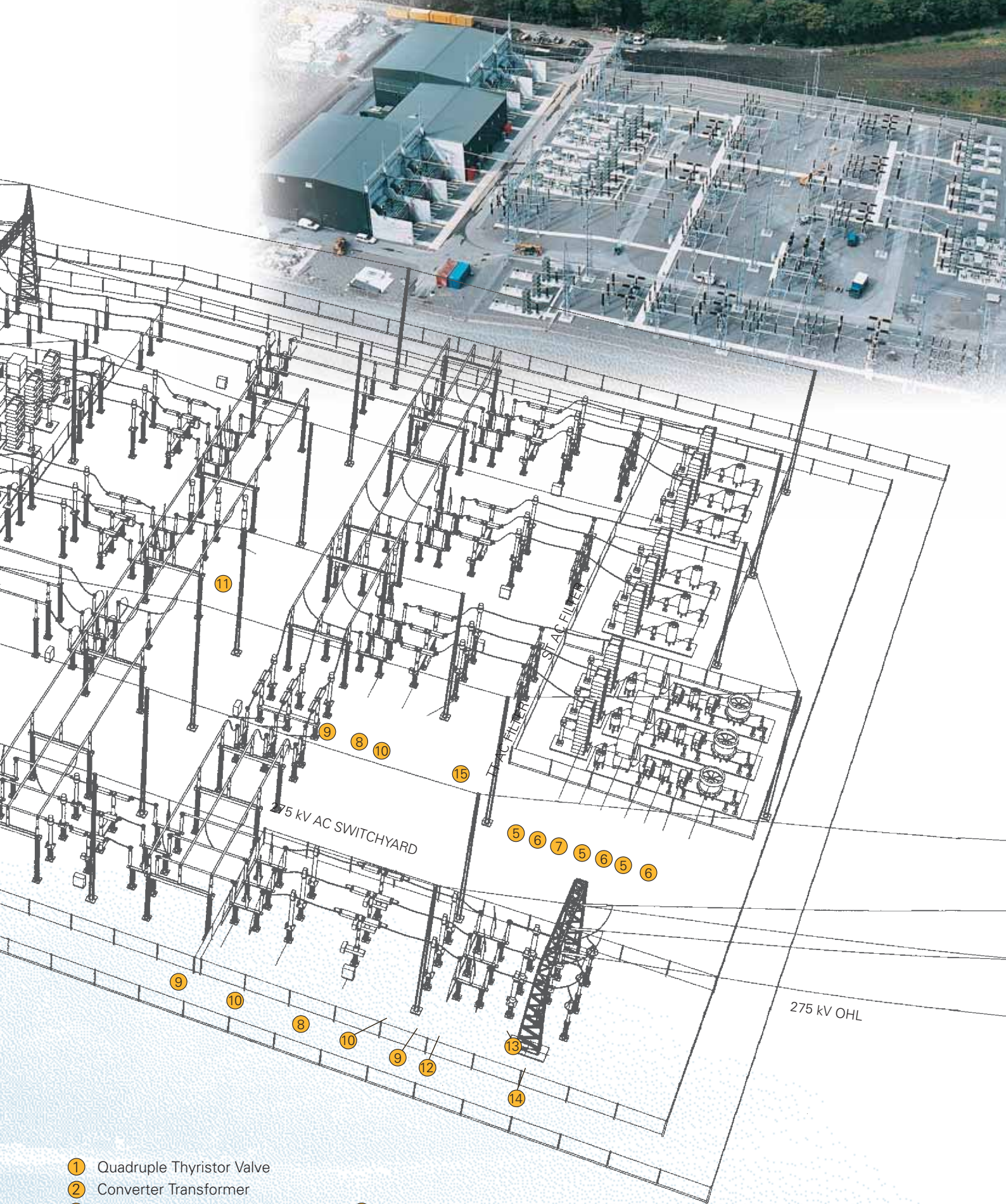

- |   |                                  |   |                                      |
|---|----------------------------------|---|--------------------------------------|
| ① | Quadruple Thyristor Valve        | ⑩ | Current Transformer                  |
| ② | Converter Transformer            | ⑪ | Voltage Transformer                  |
| ③ | Air Core Smoothing Reactor       | ⑫ | Combined Current-Voltage Transformer |
| ④ | Control Room and Control Cubicle | ⑬ | Capacitive Voltage Transformer       |
| ⑤ | AC Filter Capacitor              | ⑭ | Surge Arrester                       |
| ⑥ | AC Filter Reactor                | ⑮ | Earthing Switch                      |
| ⑦ | AC Filter Resistor               | ⑯ | AC PLC Filter                        |
| ⑧ | Circuit Breaker                  |   |                                      |
| ⑨ | Disconnecter                     |   |                                      |



# 5 Main Components

## Components

Siemens is a leading supplier of HVDC systems all over the world. Our components are exceeding the usual quality standards and are system-tailored to the needs of the grid.

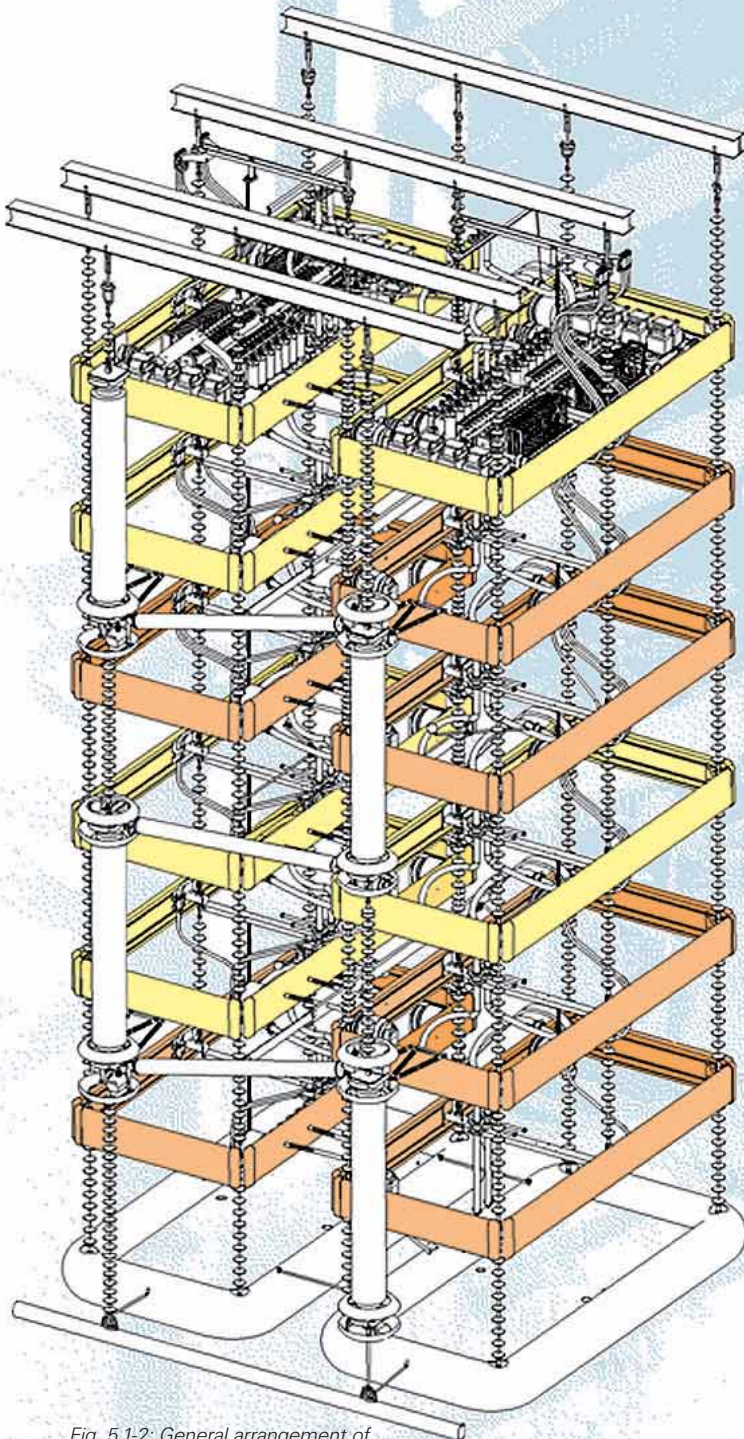

Fig. 5.1-2: General arrangement of a 500 kV MVU (valve tower)

## 5.1.1 Introduction

The thyristor valves make the conversion from AC into DC and thus are the central component of any HVDC converter station. The thyristor valves are of the indoor type and air-insulated. Siemens has more than 30 years experience in the development and manufacturing of thyristor valves and has maintained the technical leadership by introducing new innovative concepts such as the corrosion-free water cooling and the self-protecting direct-light-triggered thyristor. This directly reflects in the high reliability of these valves.

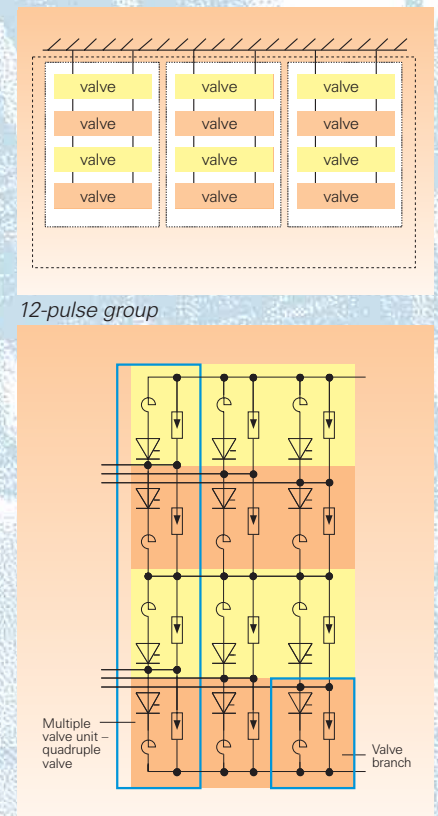

Fig. 5.1-1: Principle circuit diagram of a 12-pulse group consisting of three quadruple valves



### 5.1.2 Valve Design

The modular concept of the Siemens thyristor valves permits different mechanical setups to best suit each application: single, double, quadruple valves or complete six-pulse bridges – either free – standing or suspended from the building structure.

For seismic requirement reasons which exist in some regions of the world, the standard Siemens valves for long distance transmission are suspended from the ceiling of the valve hall. The suspension insulators are designed to carry the weight and additional loads originating for example from an unbalanced weight distribution due to insulator failure, an earthquake or during maintenance. Connections between modules (piping of cooling circuit, fibre optic ducts, buswork, and suspension insulator fixtures) are flexible in order to allow stress-free deflections of the modules inside an MVU (multiple valve unit) structure. Figure 5.1-2 shows a typical quadruple valve tower for a 500 kV DC system. Each valve is made up of three modules. Four arresters, each related to one valve, are located on one side of the valve tower. Ease of access for maintenance purposes, if required, is another benefit of the Siemens valve design. By varying the number of thyristors per module and the number of modules per valve, the same design can be used for all transmission voltages that may be required.



# 5.1 Thyristor Valves

## 5.1.3 Thyristor Development

Thyristors are used as switches and thus the valve becomes controllable. The thyristors are made of highly pure monocrystalline silicon. The high speed of innovation in power electronics technology is directly reflected in the development of the thyristor. The high performance thyristors installed in HVDC plants today are characterized by silicon wafer diameters of up to 5" (125 mm), blocking

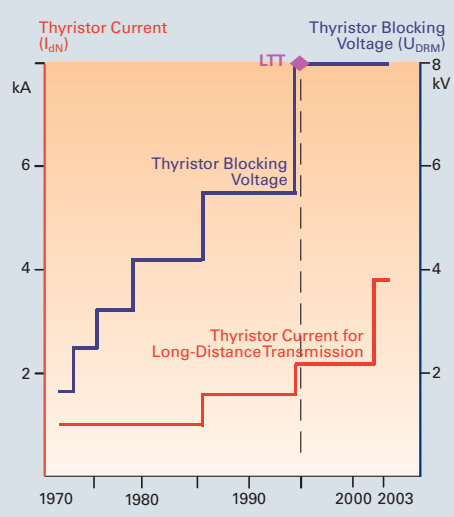

Fig. 5.1-3: Thyristor development

voltages up to 8 kV and current carrying capacities up to 4 kA DC. Thus no parallel thyristors need to be installed in today's HVDC systems for handling the DC current. The required DC system voltages are achieved by a series connection of a sufficient number of thyristors.

Cu	=	Copper
Si	=	Silicon
Mo	=	Molybdenum
LTT	=	Light-triggered thyristors
ETT	=	electrically triggered thyristors

## 5.1.4 LTT (Light-Triggered Thyristor)

It has long been known that thyristors can be turned on by injecting photons into the gate instead of electrons. The use of this new technology reduces the number of components in the thyristor valve by up to 80%. This simplification results in increased reliability and availability of the transmission system. With LTT technology, the gating light pulse is transmitted via a fibre optic cable through the thyristor housing directly to the thyristor wafer and thus no elaborate electronic circuits and auxiliary power supplies are needed at high potential. The required gate power is just 40 mW. The forward overvoltage protection is integrated in the wafer. Further benefits of the direct light triggering are the unlimited black start capability and the operation during system undervoltage or system faults without any limitations. In case of electrically triggered thyristors (ETT), this is only possible if enough firing energy is stored long enough on the thyristor electronics.

Direct light-triggered thyristors with integrated overvoltage protection (LTT) is now a proven technology and the Siemens standard. It was implemented successfully for the first time in 1997 (Celilo Converter Station of the Pacific Intertie). It shows excellent performance and no thyristor failures or malfunction of the gating system have been recorded. BPA has emphasized its confidence in this technology in 2001 by awarding Siemens the contract to replace all mercury arc valves with direct-light-triggered thyristor valves. Furthermore, this valve technology is used for the Moyle Interconnector (2 x 250 MW), which went into service in 2001 and is on contract for the 3000-MW, ± 500-kV Guizhou-Guangdong system.

Monitoring of the thyristor performance is achieved by a simple voltage divider circuit made from standard off-the-shelf resistors and capacitors; monitoring signals are transmitted to ground potential through a dedicated set of fibre optic cables as for the ETT. However, all electronic circuits needed for the evaluation of performance are now located at ground potential in a protected environment, further simplifying the system. The extent of monitoring is the same as for the ETT.

It can be expected that this technology will become the industry standard in HVDC thyristor valves of the 21st century, paving the way towards maintenance-free thyristor valves.



Fig. 5.1-4: Valve module with direct-light-triggered thyristor

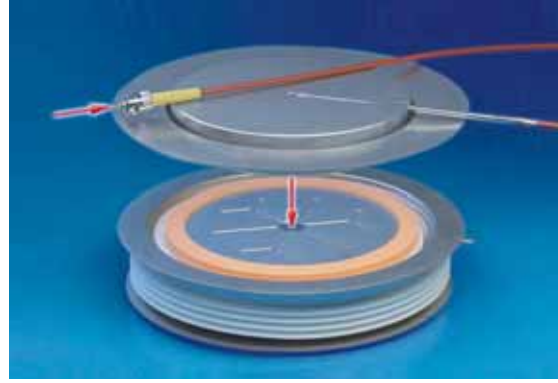

Fig. 5.1-5: Silicon wafer and housing of a direct-light-triggered thyristor

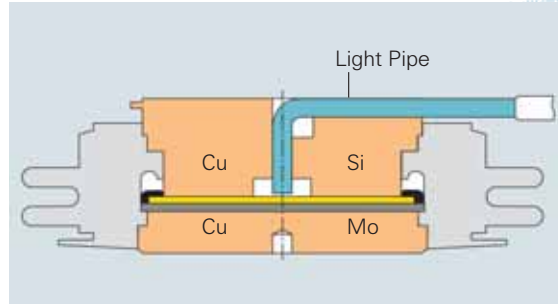

Fig. 5.1-6: The optical gate pulse is transmitted directly to the thyristor wafer



### 5.1.5 Valve Cooling

Siemens has used the parallel water cooling principle for more than 25 years. No corrosion problems have ever been encountered.

The thyristors are stacked in the module with a heat sink on either side. The water connection to the heat sinks can be designed in parallel or series as shown in figure 5.1-7. The parallel cooling circuit provides all thyristors with the same cooling water temperature. This allows a better utilization of the thyristor capability. Siemens makes use of this principle, which offers the additional advantage that electrolytic currents through the heat sinks – the cause for electrolytic corrosion – can be avoided by placing grading electrodes at strategic locations in the water circuit. Siemens water cooling also does not require any de-oxygenizing equipment.

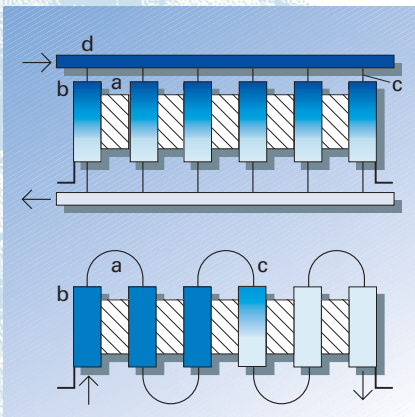

Fig. 5.1-7: Piping of module cooling circuit – parallel flow (top); series flow (bottom)  
a) thyristor; b) heat sink; c) connection piping; d) manifold

### 5.1.6 Flame Resistance

A lot of effort has been invested by Siemens to minimize the fire risk:

- All oil has been eliminated from the valve and its components. Snubber capacitors and grading capacitors use SF<sub>6</sub> as a replacement for impregnating oil.
- Only flame-retardant and self-extinguishing plastic materials are used.
- A wide separation between the modular units ensures that any local overheating will not affect neighbouring components.
- Careful design of the electrical connections avoids loose contacts.

The past has shown that Siemens HVDC installations have never been exposed to a hazardous valve fire. The tests performed on actual components and samples in the actual configuration as used in the valve indicate that the improved design is indeed flame-retardant and the risk of a major fire following a fault is extremely low or even non-existent.



Fig. 5.1-8: Converter valves  
Sylmar HVDC station, Los Angeles, USA



## 5.2 Converter Transformer

Siemens supplies transformers which meet all requirements concerning power, voltage, mode of operation, low noise level, connection techniques, type of cooling, transport and installation. They also comply with special national design requirements.

All over the world, power transformers from Nuremberg enjoy a great reputation. What the Nuremberg plant manufactures reflects today's state of the art and testifies to the highest levels of quality and reliability. Our quality management system is certified to DIN 9001, the world's most stringent standard. Our accredited test laboratories likewise meet the latest specifications.

*Project: Tian Guang  
HVDC bipolar long-  
distance transmission  
 $P_N = 2 \times 900 \text{ MW}$   
 $U_d = \pm 500 \text{ kV}$   
Transformers:  
 $S_N = 354/177/177 \text{ MVA}$   
1-ph/3-w unit  
 $U_{AC} = 220 \text{ kV}$*



Fig. 5.2-1: Converter transformer for the Tian Guang HVDC project during type test

*Converter transformer for the Three Gorges  
HVDC project 284 MVA, 1-ph/2-w unit*







### 5.2.1 Functions of the HVDC Converter Transformer

The converter transformers transform the voltage of the AC busbar to the required entry voltage of the converter.

The 12-pulse converter requires two 3-phase systems which are spaced apart from each other by 30 or 150 electrical degrees. This is achieved by installing a transformer on each network side in the vector groups Yy0 and Yd5.

At the same time, they ensure the voltage insulation necessary in order to make it possible to connect converter bridges in series on the DC side, as is necessary for HVDC technology. The transformer main insulation, therefore, is stressed by both the AC voltage and the direct voltage potential between valve-side winding and ground. The converter transformers are equipped with on-load tap-changers in order to provide the correct valve voltage.

#### Transformer Rating

$$S_{\text{Trafo Rec (6-pulse)}} = \sqrt{2} * I_{\text{dN}} * U_{\text{sec Rec}}$$

$I_{\text{dN}}$  nominal DC current  
 $U_{\text{sec Rec}}$  Transformer-voltage valve side (Rectifier)

$$S_{\text{Trafo Inv (6-pulse)}} = \sqrt{2} * I_{\text{dN}} * U_{\text{sec Inv}}$$

$U_{\text{sec Inv}}$  Transformer voltage valve side (inverter)

### 5.2.2 Transformer Design Variations

There are several aspects which play a role in selecting the transformer design:

#### Transportation Weight and Dimensions

In systems of high power, weight can be an important consideration, in particular where transportation is difficult. The relative transportation weights of the 4 major design types are approximately as follows:

Single-phase – two-winding transformer	1
Single-phase – three-winding transformer	1.6
Three-phase – two-winding transformer	2.2
Three-phase – three-winding transformer	3.6

The transport dimension and the weight of the converter transformer depends on the limitations for street, railway and shipping, especially in the case of bridges, subways and tunnels.

### 5.2.3 HVDC Makes Special Demands on Transformers

HVDC transformers are subject to operating conditions that set them apart from conventional system or power transformers. These conditions include:

- Combined voltage stresses
- High harmonics content of the operating current
- DC premagnetization of the core

The valve windings which are connected to the rectifier and the converter circuit are subject to the combined load stress of DC and AC voltage. Added to this stress are transient voltages from outside caused by lightning strikes or switching operations.

The high harmonics content of the operating current results from the virtually quadratic current blocks of the power converter. The odd-numbered harmonics with the ordinal numbers of 5, 7, 11, 13, 17 ... cause additional losses in the windings and other structural parts.

### 5.2.4 Main Components of the Converter Transformer

#### Core

HVDC transformers are normally single-phase transformers, whereby the valve windings for the star and delta connection are configured either for one core with at least two main limbs or separately for two cores with at least one main limb, depending on the rated power and the system voltage. Appropriately sized return limbs ensure good decoupling for a combined arrangement of windings.

The quality of the core sheets, the lamination of the sheets, and the nominal induction must all conform to special requirements covering losses, noise level, over-excitation, etc. Special attention must be paid to the DC premagnetization of the core due to small asymmetries during operation and stray DC currents from the AC voltage network. The effects of DC premagnetization must be compensated by appropriate design and manufacturing efforts (e.g. additional core cooling ducts, avoidance of flux pinching in the core sheet).

#### Windings

The large number of parameters concerning transport limitations, rated power, transformer ratio, short-circuit voltage, and guaranteed losses require significant flexibility in the design of windings.

In concentric winding arrangements, star or delta valve windings lying directly on the core have proven optimal in many cases. The line winding, normally with a tapped winding, is then mounted radial outside this core configuration.

The valve windings with high insulation levels and a large portion of current harmonics make particular demands on the design and the quality of the winding manufacturing. Together with its pressboard barriers, each limb set, including a valve, an overvoltage and a tapped winding, forms a compact unit, which is able to cope with the demand made by voltage stress, loss dissipation, and short-circuit withstand capability.

#### Tank

The unconventional tank design in HVDC transformers result from the following requirements:

- The valve-side bushing should extend into the valve hall
- The cooling system is mounted on the opposite side to facilitate rapid transformer exchange

For HVDC transformers with delta and star valve winding in one tank, the valve bushing must be arranged so that their ends conform to the geometry of the thyristor valve towers. This frequently leads to very high connection heights and the need to mount the oil expansion tank at a significant height.

In close cooperation with the equipment design department, the engineering specialists at the Nuremberg Transformer Plant have always been able to find a design suited to every customer requirement.

#### Bushings

Compared to porcelain, composite bushings provide better protection against dust and debris. A 15% higher DC voltage testing level compared to the windings underscores the particular safety aspect of these components.

#### Special Tests for HVDC Transformers

Special tests for verifying operating functionality are required for HVDC transformers. The applicable international standards are subject to constant further development. Separate tests with DC voltage, switching and lightning impulse voltages cover the range of different voltage loads. The 2-MV DC voltage generator in the Nuremberg Transformer Plant is well-suited for all required DC voltage and reverse poling tests. The most important criterion is partial discharge. A maximum of 10 discharges over 2000 pC during the last 10 minutes of the test is permitted.



## 5.3.1 Functions of the Smoothing Reactor

- Prevention of intermittent current
- Limitation of the DC fault currents
- Prevention of resonance in the DC circuit
- Reducing harmonic currents including limitation of telephone interference

### Prevention of intermittent current

The intermittent current due to the current ripple can cause high over-voltages in the transformer and the smoothing reactor. The smoothing reactor is used to prevent the current interruption at minimum load.

### Limitation of the DC fault current

The smoothing reactor can reduce the fault current and its rate of rise for commutation failures and DC line faults.

This is of primary importance if a long DC cable is used for the transmission. For an overhead line transmission, the current stress in valves is lower than the stress which will occur during valve short circuit.

### Prevention of resonance in the DC circuit

The smoothing reactor is selected to avoid resonance in the DC circuit at low order harmonic frequencies like 100 or 150 Hz. This is important to avoid the amplification effect for harmonics originally from the AC system, like negative sequence and transformer saturation.

### Reducing harmonic currents including limitation of telephone interference

Limitation of interference coming from the DC overhead line is an essential function of the DC filter circuits. However, the smoothing reactor also plays an important role to reduce harmonic currents acting as a series impedance.

## 5.3.2 Sizing of the smoothing Reactor

While the current and voltage rating of the smoothing reactor can be specified based on the data of the DC circuit, the inductance is the determining factor in sizing the reactor. Taking all design aspects above into account, the size of

smoothing reactors is often selected in the range of 100 to 300 mH for long-distance DC links and 30 to 80 mH for back-to-back stations.

## 5.3.3 Arrangement of the Smoothing Reactor

In an HVDC long-distance transmission system, it seems quite logical that the smoothing reactor will be connected in series with the DC line of the station pole. This is the normal arrangement. However in back-to-back schemes, the smoothing reactor can also be connected to the low-voltage terminal.

## 5.3.4 Reactor Design Alternatives

There are basically two types of reactor design:

- Air-insulated dry-type reactors
- Oil-insulated reactors in a tank

The reactor type should be selected taking the following aspects into consideration:

- Inductance
- Costs
- Maintenance and location of spare units
- Seismic requirements

An advantage of the dry-type reactor is that maintaining spare units (to the extent necessary) is not very expensive because they usually consist of several partial coils. However for very large inductances it is possible to have more than one unit and it could be a problem if much space is not available.

In high seismic regions, setting them on post-insulators or on an insulating platform is a possible problem. Oil-insulated smoothing reactors are then the preferred solution.

The oil-insulated reactor is economical for very high power ( $I_d^2 * L_{dr}$ ). It is the best option for regions with high seismic requirements.

One bushing of the oil-insulated smoothing reactor penetrates usually into the valve hall, while the other bushing is normally in a vertical position. For the air-insulated dry-type smoothing reactor, a wall bushing is needed to connect with the valves.

The wall bushing in composite design is the state-of-the-art technology which provides superior insulation performance.



Fig. 5.3-1: Oil-insulated smoothing reactor – Three Gorges project

- Inductance: 270 mH
- Rated voltage: 500 kV DC
- Rated current: 3000 A DC



Fig. 5.3-2: Air-insulated smoothing reactor – Tian Guang project

- Inductance: 150 mH
- Rated voltage: 500 kV DC
- Rated current: 1800 A DC



## 5.4 Harmonic Filters

The filter arrangements on the AC side of an HVDC converter station have two main duties:

- to absorb harmonic currents generated by the HVDC converter and thus to reduce the impact of the harmonics on the connected AC systems, like AC voltage distortion and telephone interference
- to supply reactive power for compensating the demand of the converter station

Each filter branch can have one to three tuning frequencies. Figure 5.4.1-1 shows different harmonic filter types with their impedance frequency characteristics.

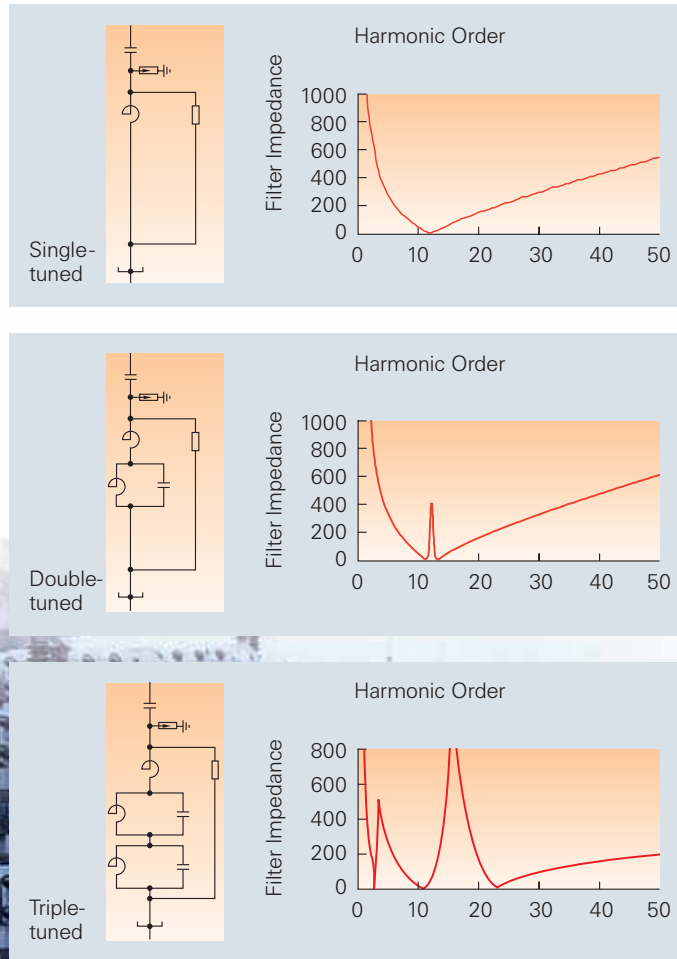

Fig. 5.4.1-1:  
Different harmonic  
filter types

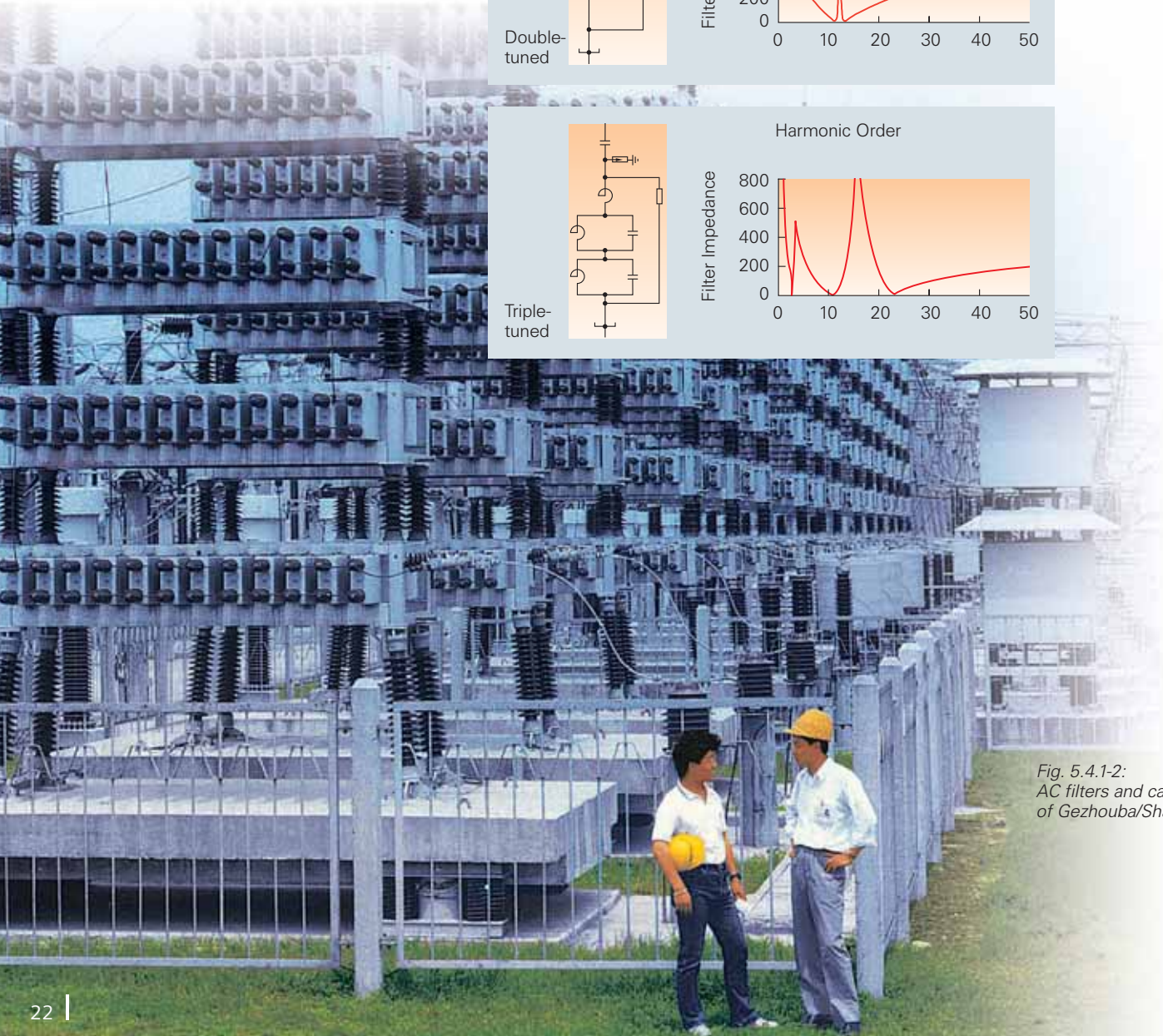

Fig. 5.4.1-2:  
AC filters and capacitor banks  
of Gezhouba/Shanghai



### 5.4.1.1 Design Criteria for AC Filters

#### Reactive Power Requirements

The reactive power consumption of an HVDC converter depends on the active power, the transformer reactance and the control angle. It increases with increasing active power. A common requirement to a converter station is full compensation or overcompensation at rated load. In addition, a reactive band for the load and voltage range and the permitted voltage step during bank switching must be determined. These factors will determine the size and number of filter and shunt capacitor banks.

#### Harmonic Performance Requirements

HVDC converter stations generate characteristic and non-characteristic harmonic currents. For a twelve-pulse converter, the characteristic harmonics are of the order  $n = (12 \cdot k) \pm 1$  ( $k = 1, 2, 3 \dots$ ). These are the harmonic components that are generated even during ideal conditions, i.e. ideal smoothing of the direct current, symmetrical AC voltages, transformer impedance and firing angles. The characteristic harmonic components are the ones with the highest current level, but other components may also be of importance. The third harmonic, which is mainly caused by the negative sequence component of the AC system, will in many cases require filtering.

An equivalent circuit for determination of harmonic performance is given in figure 5.4.1-3. The most commonly used criteria for harmonic performance are

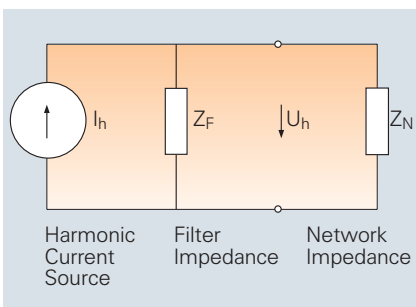

Fig. 5.4.1-3: Equivalent circuit for calculation of harmonic voltages and currents in the AC system

related to the harmonic voltage on the converter station busbar. The purpose of the filter circuit is to provide sufficiently low impedances for the relevant harmonic components in order to reduce the harmonic voltages to an acceptable level.

The acceptance criteria for the harmonic distortion depend on local conditions and regulations. A commonly used criterion for all harmonic components up to the 49th order is as follows:

- $D_n$  individual harmonic voltage distortion of order  $n$  in percent of the fundamental AC busbar voltage (typical limit 1%)
- $D_{rms}$  total geometric sum of individual voltage distortion  $D_n$  (typical limit 2%)

The BTS Telephone Interference Factor (TIF) and the CCITT Telephone Harmonic Form Factor (THFF) are determined with weighted factors in order to evaluate the voltage distortion level on the AC busbar with respect to the expected interference level in nearby analogue telephone systems. The IT product is a criterion for harmonic current injected into AC overhead lines. The criteria based on telephone interference are in many cases irrelevant, because modern digital telephone systems are insensitive to harmonic interference.

#### Network Impedance

The distortion level on the AC busbar depends on the grid impedance as well as the filter impedance. An open circuit model of the grid for all harmonics is not on the safe side. Parallel resonance between the filter impedance and the grid impedance may create unacceptable amplification of harmonic components for which the filters are not tuned. For this reason, an adequate impedance model of the grid for all relevant harmonics is required in order to optimize the filter design.

There are basically two methods to include the network impedance in the filter calculations:

- to calculate impedance vectors for all relevant harmonics and grid conditions
- to assume locus area for the impedance vectors

The modelling of a complete AC network with all its components is very complex and time-consuming. For this reason, the locus method is very often used. It is based on a limited number of measurements or calculations. Different locus areas for different harmonics or bands are often determined to give a more precise base for the harmonic performance calculation.

A typical locus area is shown in fig. 5.4.1-4. It is assumed that the impedance vector will be somewhere inside the perimeter of the coloured area.

The impedance vector of the filter is transformed into the Y plane for each harmonic frequency.

With both the network and the filter impedances plotted in the admittance plane, the shortest vector between the filter admittance point and the network admittance boundary gives the lowest possible admittance value for the parallel combination of the network and the filter. This value is used to determine the highest possible harmonic voltage.

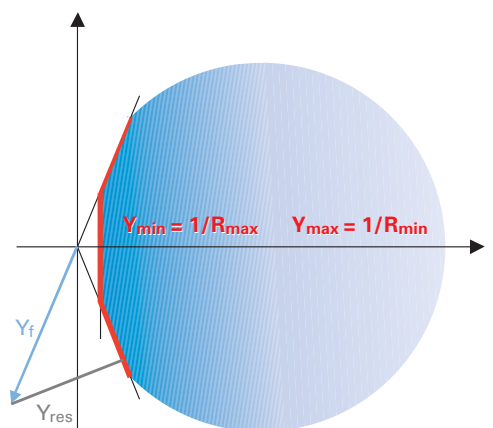

Fig. 5.4.1-4 Circle of network admittance and the resonance conditions

$I_h$	=	harmonic source current
$Z_f$	=	filter impedance
$Z_N$	=	network impedance
$U_h$	=	harmonic voltage

## 5.4.1 AC Harmonic Filter

The selective resonance method represents a reasonable compromise. It takes into consideration the fact that the highest voltage distortion (highest harmonic voltage) occurs with a parallel resonance between filter and AC network. It is unrealistic however, to assume that such a parallel resonance takes place at all frequencies. Normally it is sufficient to consider in the calculation of total distortion and TIF value only two maximum individual distortions from the resonance calculation. The AC network is assumed to be open for the remaining harmonic currents.

The filter calculations must reflect detuning caused by AC network frequency deviations and component parameter deviations. Production tolerances, temperature drift and failure of capacitor elements are the main contributors to parameter deviations.

### Requirements to Ratings

#### Steady-State Calculation

The voltage and current stresses of AC filters consist of the fundamental frequency and harmonic components. Their magnitudes depend on the AC system voltage, harmonic currents, operating conditions and AC system impedances. The rating calculations are carried out in the whole range of operation to determine the highest steady-state current and voltage stresses for each individual filter component.

#### Transient Calculation

The objective of the transient rating calculation is to determine the highest transient stresses for each component of the designed filter arrangement. The results of the transient calculation should contain the voltage and current stresses for each component, energy duty for filter resistors and arresters, and the insulation levels for each filter component.

To calculate the highest stresses of both lightning and switching surge type, different circuit configurations and fault cases should be studied:

- **Single-Phase Ground Fault**

The fault is applied on the converter AC bus next to the AC filter. It is assumed that the filter capacitor is charged to a voltage level corresponding to the switching impulse protective level of the AC bus arrester.

- **Switching Surge**

For the calculation of switching surge stresses, a standard wave of 250/2500  $\mu$ s with a crest value equal to the switching impulse protective level of the AC bus arrester is applied at the AC converter bus.

- **Filter Energization**

The AC filter is assumed to be energized at the moment for the maximum AC bus peak voltage. This case is decisive for the inrush currents of AC filters.

- **Fault Recovery after Three-Phase Ground Fault**

Various fault-clearing parameters should be investigated to determine the maximum energy stresses for AC filter arresters and resistors. The worst-case stresses are achieved if the HVDC converters are blocked after fault initiation, while the AC filters remain connected to the AC bus after fault clearing and recovery of the AC system voltage. In this case, a temporary overvoltage with high contents of non-characteristic harmonics will occur at the AC bus due to the effects of load rejection, transformer saturation and resonance between filter and AC network at low frequency.

Fig. 5.4.2-1 DC filter of Guangzhou/China



## 5.4.2.1 DC Filter Circuits

Harmonic voltages which occur on the DC side of a converter station cause AC currents which are superimposed on the direct current in the transmission line. These alternating currents of higher frequencies can create interference in neighbouring telephone systems despite limitation by smoothing reactors. DC filter circuits, which are connected in parallel to the station poles, are an effective tool for combating these problems. The configuration of the DC filters very strongly resembles the filters on the AC side of the HVDC station. There are several types of filter design. Single and multiple-tuned filters with or without the high-pass feature are common. One or several types of DC filter can be utilized in a converter station.

## 5.4.2.2 Design Criteria for DC Filter Circuits

The interference voltage induced on the telephone line can be characterized by the following equation:

$$I_{eq} = \sqrt{\sum_{\mu}^m (H_{\mu} * C_{\mu} * I_{\mu(x)})^2}$$

$$V_{in(x)} = Z * I_{eq}$$

where

- $V_{in(x)}$  = Interference voltage on the telephone line at point x (in mV/km)
- $H_{\mu}$  = Weighting factors which reflect the frequency dependence of the coupling between telephone and HVDC lines
- $C_{\mu}$  = "C message" – weighting factors
- $I_{\mu(x)}$  = Resulting harmonic current of the ordinal number  $\mu$  in the HVDC line at point x as the vector sum of the currents caused by the two HVDC stations
- $I_{eq}$  = Psophometric weighted equivalent disturbing current
- $Z$  = Mutual coupling impedance between the telephone and HVDC lines

The equivalent disturbing current combines all harmonic currents with the aid of weighting factors to a single interference current. With respect to telephone interference, it is the equivalent to the sum of all harmonic currents. It also encompasses the factors which determine the coupling between the HVDC and telephone lines:

- Operating mode of the HVDC system (bipolar or monopolar with metallic or ground return)
- Specific ground resistance at point x

The intensity of interference currents is strongly dependent on the operating condition of the HVDC. In monopolar operation, telephone interference is significantly stronger than in bipolar operation.

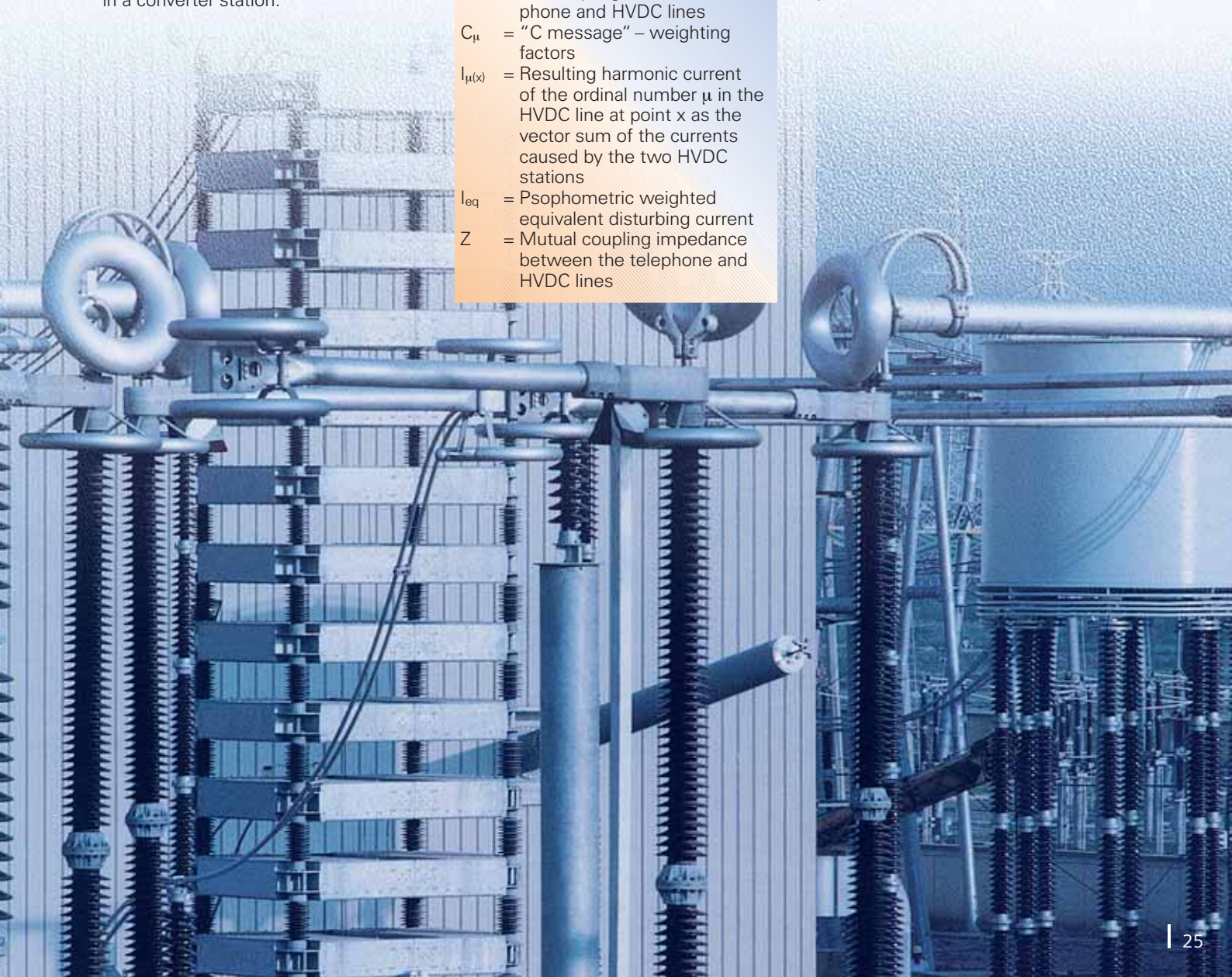



## 5.4.3 Active Harmonic Filter



Fig. 5.4.3-1: Active DC filter on site (Tian Guang HVDC project)

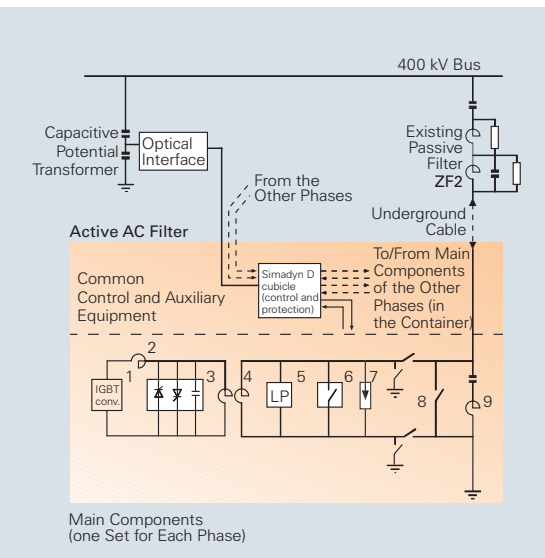

Fig. 5.4.3-2: Single-line diagram of the active AC filter. All phases have the same topology.

Active filters can be a supplement to passive filters due to their superior performance. They can be installed on the DC side or on the AC side of the converter. The connection to the high-voltage system is achieved by means of a passive filter, forming a so-called hybrid filter. This arrangement limits the voltage level and the transient stresses on the active part, so that comparatively low equipment ratings can be used. Appropriate design allows the exploitation of the positive characteristics of both passive and active filters. Additionally, the passive part can be used as a conventional passive filter if the active part is by-passed for maintenance purposes.

### Main Components

No. Component

- 1 IGBT converter
- 2 Reactor for inductivity adapting
- 3 Thyristor switch for converter overvoltage and overcurrent protection
- 4 Transformer
- 5 Low-pass filter
- 6 Vacuum switch
- 7 ZnO arrester
- 8 Isolators and grounding switches
- 9 LC branch for deviating the 50-Hz current component

A transformer matches the voltage and current levels at the converter output and provides the required insulation level. The goal of the scheme is to inject harmonics in the network with the same amplitude and the opposite phase of the harmonics at the measurement point in order to cancel them.

The filter for AC application comprises three single-phase systems controlled by a common digital control system. A major difference is the measurement: instead of measuring the line current, the active filter at Tjele measures and eliminates harmonics at the 400 kV AC busbars of the station. This has the advantage that the harmonic control requires just one measurement point, compared to a current measuring scheme, which would require to measure the current at several points and combining the measured signals. The other advantage is that the active filter works just like a passive filter ideally should do, i.e. eliminating the voltage in the bus, thus representing no change in philosophy.

The active filter is fully assembled in a transportable container and is tested at the factory as a complete system before shipping. Fig. 5.4.3-5 shows the installed active AC filter (in the container) at the Tjele substation.

The Siemens active filters use voltage-sourced IGBT converters with a high switching frequency to produce an output voltage up to approximately  $700 V_{peak}$ , containing harmonics up to the 50<sup>th</sup> as required. A powerful high-speed control and protection system processes the currents and/or voltages measured at the network by appropriate sensors and produces the control pulses for the IGBT's.



One harmonic controller is dedicated to each harmonic selected for elimination by the action of the active filter. In these harmonic controllers, the particular harmonic is isolated and expressed by a complex signal in the frequency domain.

This is done through multiplication by  $\sin(h\omega t)$  and  $\cos(h\omega t)$ , where  $h$  is the order of the harmonic,  $\omega$  the network angular frequency and  $t$  the time. These two orthogonal signals are produced by a module synchronized by the fundamental component of the filter current. The signal pair obtained after the mentioned multiplication and filtering feeds a complex controller with PI characteristic. The output of the controller is then shifted back to the time domain by multiplication by  $\cos(h\omega t)$  and  $\sin(h\omega t)$ .

The process is essentially linear, so that all harmonic controllers can operate simultaneously and the sum of all harmonic controller outputs gives the waveform required by the active filter. This signal is then given to the IGBT control module, which includes a pulse width modulator besides functions for protection and supervision of the converter.

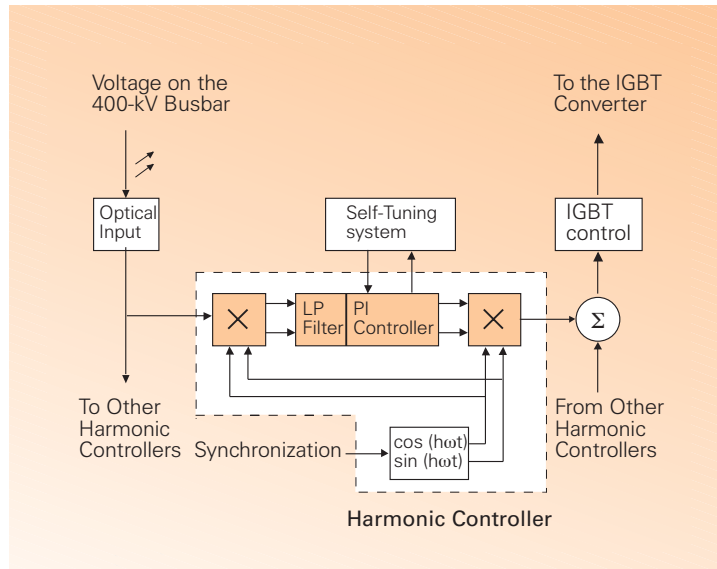

Fig. 5.4.3-3: Principle block diagram of the harmonic control

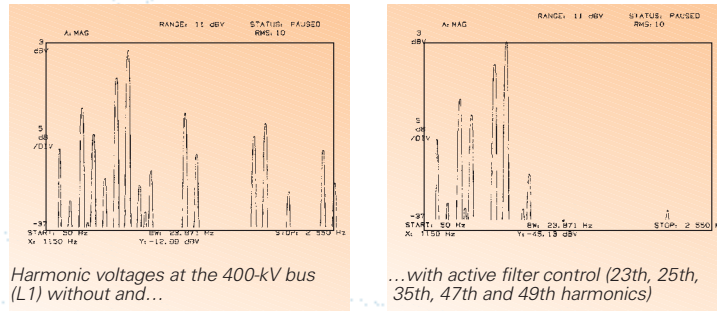

Fig. 5.4.3-4: Plots from measurement: left without, right with active filter control



Fig. 5.4.3-5: Installation of the active AC filter, 400-kV substation Tjele (Denmark)

## 5.5 Surge Arrester

Siemens surge arresters are designed optimally to the following requirements:

**Excellent pollution performance for coastal and desert regions or in areas with extreme industrial air pollution.**

**High mechanical stability, e.g. for use in seismic zones.**

**Extremely reliable pressure relief behaviour for use in areas requiring special protection.**

What is more, all Siemens surge arresters are sized for decades and the material used provides a contribution towards the protection of the environment.

The main task of an arrester is to protect the equipment from the effects of overvoltages. During normal operation, it should have no negative effect on the power system. Moreover, the arrester must be able to withstand typical surges without incurring any damage. Non-linear resistors with the following properties fulfil these requirements:

- Low resistance during surges so that overvoltages are limited
- High resistance during normal operation in order to avoid negative effects on the power system and
- Sufficient energy absorption capability for stable operation

MO (Metal Oxide) arresters are used in medium-, high- and extra-high-voltage power systems.

Here, the very low protection level and the high energy absorption capability provided during switching surges are especially important. For high voltage levels, the simple construction of MO arresters is always an advantage.

### Arresters with Polymer Housings

Fig. 5.5-2 shows two Siemens MO arresters with different types of housing. In addition to what has been usual up to now – the porcelain housing – Siemens offers also the latest generation of high-voltage surge arresters with polymer housing.

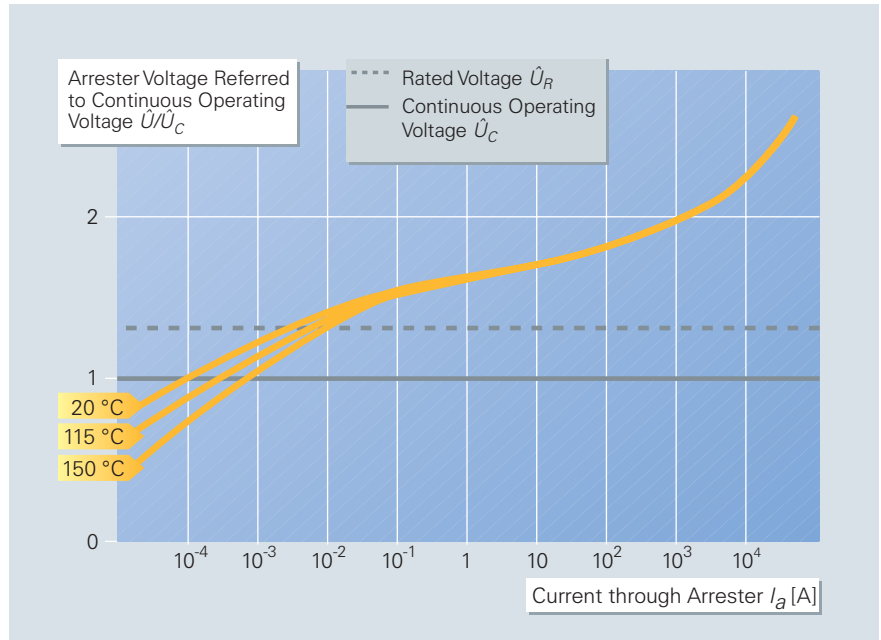

Fig. 5.5-1: Current/voltage characteristics of a non-linear MO arrester



Fig. 5.5-2: Measurement of residual voltage on porcelain-housed (foreground) and polymer-housed (background) arresters



Fig. 5.5-3 shows the sectional view of such an arrester. The housing consists of a fibre-glass-reinforced plastic tube with insulating sheds made of silicon rubber. The advantages of this design which has the same pressure relief device as an arrester with porcelain housing are absolutely safe and reliable pressure relief characteristic, high mechanical strength even after pressure relief and excellent pollution-resistant properties. The very good mechanical features mean that Siemens arresters with polymer housing (type 3EQ/R) can serve as post insulators as well. The pollution-resistant properties are the result of the water-repellent effect (hydrophobicity of the silicon rubber).

The polymer-housed high-voltage arrester design chosen by Siemens and the high-quality materials used by Siemens provide a whole series of advantages including long life and suitability for outdoor use, high mechanical stability and ease of disposal.

For terminal voltage lower than the permissible maximum operating voltage (MCOV), the arrester is capacitive and carries only few milli-amps. Due to its extreme non-linear characteristics, the arrester behaves at higher voltages as low-ohmic resistor and is able to discharge high current surges. Through parallel combination of two or more matched arrester columns, higher energy absorption capability of the ZnO arrester can be achieved.

Routine and type tests have been determined in accordance with the international standards:

- IEC 60060 High-voltage test techniques
- IEC 60071 Insulation coordination
- IEC 60099 Surge arresters

Fig. 5.5-3: Cross-section of a polymer-housed arrester

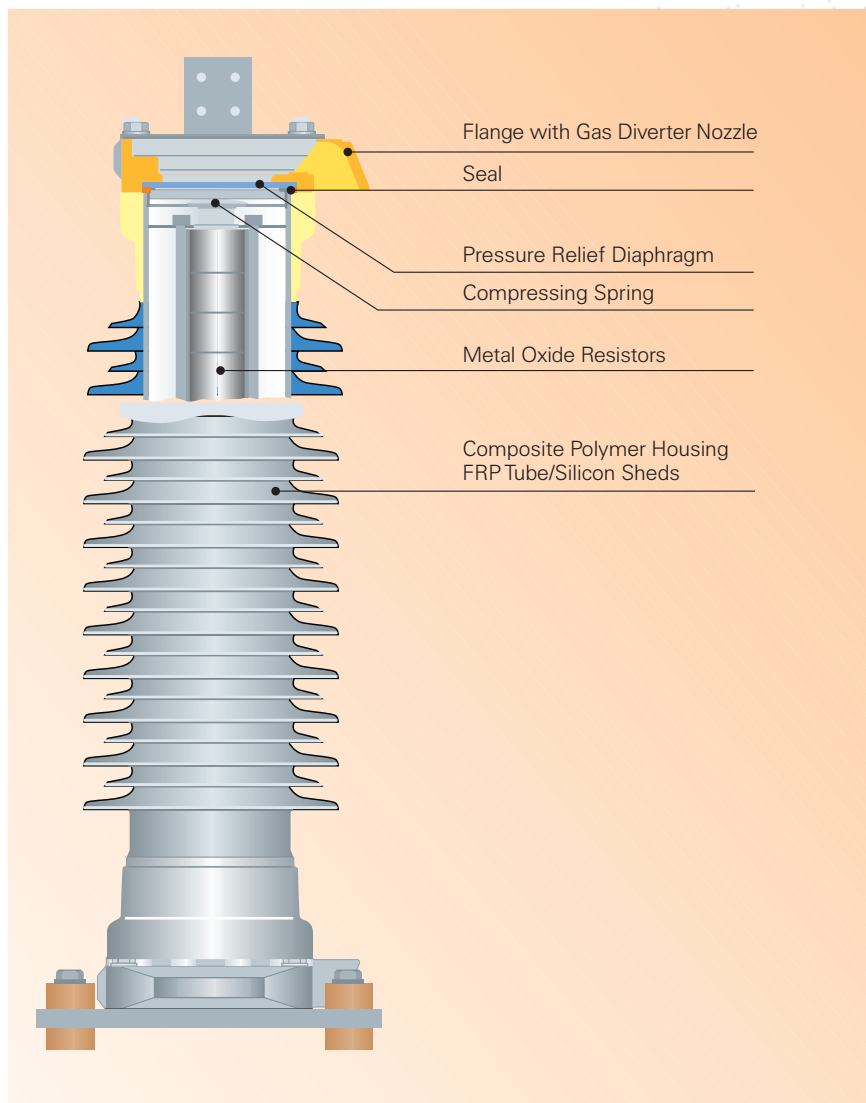

## 5.5 Surge Arrester

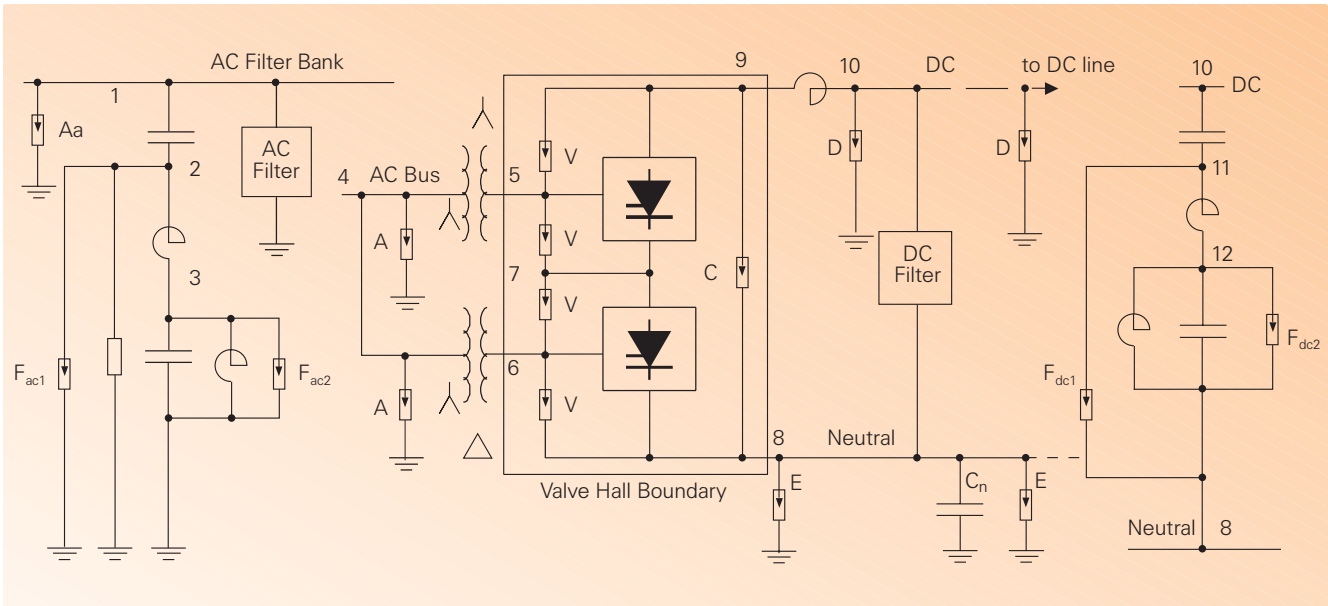

Arrester Type	Location	Main Task
AC bus arrester 'A'	The ZnO arrester will be installed close to the converter transformer line side bushing	Limit the overvoltages on the primary and secondary side of the converter transformer
AC filter bus arrester 'Aa'	The ZnO arrester will be installed at the busbar of the AC filter banks	Protect the AC filters busbar against lightning surges
Valve-arrester 'V'	3-pulse commutation group	The main events to be considered with respect to arrester discharge currents and energies are: a) Switching surges from the AC system through converter transformer b) Ground fault between valve and HV bushing of converter transformer during rectifier operation
Converter group arrester 'C'	12-pulse converter group	Protection against overvoltages from the AC and DC side
DC bus arrester 'D'	At the HV smoothing reactor and at the DC lines	They will protect the smoothing reactor and the converter station (e.g. DC switchyard) against overvoltages coming from the DC side
Neutral DC bus arrester 'E'	Neutral DC bus	The neutral bus arresters protect the LV terminal of the 12-pulse group and the neutral bus equipment
AC filter arrester 'F <sub>ac</sub> '	AC filter	The operating voltage for the AC filter arresters consists of low fundamental frequency and harmonic voltages. Overvoltages can occur transiently during faults
DC filter arrester 'F <sub>dc</sub> '	DC filter	The operating voltage for the DC filter arresters consists of low DC component and harmonic voltages. Overstresses may occur transiently during DC bus fault to ground



## 5.6.1 DC Transmission Line

DC transmission lines could be part of overall HVDC transmission contract either within a turnkey package or as separately contracted stand-alone item, later integrated into an HVDC link.

As an example of such a transmission line design, an existing bipolar tower for the 300-kV link between Thailand and Malaysia is shown in Fig.5.6.1-1.



Fig. 5.6.1-1:  
DC transmission line  
(bipolar tower 300-kV link)

### 5.6.1.1 Towers

Such DC transmission lines are mechanically designed as it is practice for normal AC transmission lines; the main differences are:

- The conductor configuration
- The electric field requirements
- The insulation design

### 5.6.1.2 Insulation

The most critical aspect is the insulation design and therefore this topic is described more detailed below:

For DC transmission lines, the correct insulation design is the most essential subject for an undisturbed operation during the lifetime of the DC plant.

#### Design Basics

- The general layout of insulation is based on the recommendations of IEC 60815 which provides 4 pollution classes.
- This IEC is a standard for AC lines. It has to be observed that the creepage distances recommended are based on the phase-to-phase voltage ( $U_{L-L}$ ). When transferring these creepage distances recommended by IEC 60815 to a DC line, it has to be observed that the DC voltage is a peak voltage pole to ground value ( $U_{L-G}$ ). Therefore, these creepage distances have to be multiplied by the factor  $\sqrt{3}$ .
- Insulators under DC voltage operation are subjected to more unfavourable conditions than under AC due to higher collection of surface contamination caused by constant unidirectional electric field. Therefore, a DC pollution factor as per recommendation of CIGRE (CIGRE-Report WG04 of Cigre SC33, Mexico City 1989) has to be applied.

The correction factors are valid for porcelain insulators only. When taking composite insulators into consideration, additional reduction factors based on the FGH report 291 "Oberflächenverhalten von Freiluftgeräten mit Kunststoffgehäusen" must be applied.

## 5.6.1 DC Transmission Line

### Types of Insulators

There are 3 different types of insulators applicable for DC transmission lines:

- Cap and pin type
- Long-rod porcelain type
- Composite long-rod type

In detail:

#### Cap and Pin Type

##### Positive Aspects:

- Long-term experience/track record
- Good mechanical strength
- Vandalism-proof
- Flexibility within the insulator string

##### Negative Aspects:

- Very heavy strings
- Insulator not puncture-proof
- Poor self-cleaning ability
- Loss of strength/reliability due to corrosion of pin in polluted areas caused by high track current density (this is extremely important for DC lines)
- Many intermediate metal parts
- High RIV and corona level
- For DC applications, special shed design and porcelain material necessary
- Very expensive

### Long-Rod Porcelain Type

##### Positive Aspects:

- Long-term experience/track record
- Good mechanical strength
- Puncture-proof
- Good self-cleaning ability
- Less intermediate metal parts
- Due to caps on both insulator ends not subjected to pin corrosion because of low track current density
- Moderate price

##### Negative Aspects:

- Heavy strings
- String not very flexible
- Under extreme vandalism failure of string possible

### Composite Long-Rod Type

##### Positive Aspects:

- Small number of insulators in one string
- Up to 400 kV per unit possible
- Good mechanical strength, no chipping of sheds possible
- Very light – easy handling during construction and maintenance, logistical advantages in areas with poor access
- Puncture-proof
- Good self-cleaning behaviour – hydrophobicity of surface which offers advantages of less creepage distance up to pollution class II
- Very good RIV and corona behaviour
- Good resistance against vandalism
- Shorter insulator string length
- Very competitive price

##### Negative Aspects:

- Relatively short track record in DC application (since 1985 first major application in the USA)
- Less tracking resistance against flash-over (can be improved by means of corona rings)



### Example/Comparison of Insulator Application for a 400 kV Transmission Line

	Cap and Pin	Porcelain Long-Rod	Composite Long-Rod
Insulator string length	5270 mm 31 insulators	5418 mm 4 insulators	4450 mm 1 insulator
Creepage per unit	570 mm	4402 mm	17640 mm
Weight of string	332 kg	200 kg	28 kg
Breaking load	160 kN	160 kN	160 kN



**5.6.2.1 General Application for DC Cables**

An important application for HVDC are transmission systems crossing the sea. Here, HVDC is the preferred technology to overcome distances > 70 km and transmission capacities from several hundred to more than a thousand MW (for bipolar systems). For the submarine transmission part, a special cable suitable for DC current and voltage is required.

**5.6.2.2 Different Cable Types**

For HVDC submarine cables there are different types available.

1) Mass-impregnated Cable

This cable type is used in most of the HVDC applications. It consists of different layers as shown in Fig. 5.6.2.2-1.

The conductor is built of stranding copper layers of segments around a central circular rod. The conductor is covered by oil and resin-impregnated papers. The inner layers are of carbon-loaded papers whereas the outer layer consists of copper-woven fabrics. The fully impregnated cable is then lead-sheathed to keep the outside environment away from the insulation. The next layer is the anti-corrosion protection which consists of extruded polyethylene. Around the polyethylene layer galvanized steel tapes are applied to prevent the cable from permanent deformation during cable loading. Over the steel tapes a polypropylene string is applied followed by galvanized steel wire armour. The technology is available for voltages up to 500 kV and a transmission capacity of up to 800 MW in one cable with installation depths of up to 1000 m under sea level and nearly unlimited transmission lengths. The capacity of mass-impregnated cables is limited by the conductor temperature which results in low overload capabilities.

2) Oil-Filled Cable

In comparison to mass-impregnated cables, the conductor is insulated by paper impregnated with a low-viscosity oil and incorporates a longitudinal duct to permit oil flow along the cable. Oil-filled cables are suitable for both AC and DC voltages with DC voltages up to 600 kV DC and great sea depths. Due to the required oil flow along the cable, the transmission line lengths are however limited to <100 km and the risk of oil leakage into the environment is always subject to discussions.

**5.6.2.3 Future Developments for HVDC Cables**

Most of the research and development activities for new cable types are done with the insulation material. These include:

1) XLPE

To overcome the disadvantages of the above mentioned cable types, extensive R&D was conducted by the cable suppliers. The result is the XLPE cable. XLPE means 'cross-linked polyethylene' and forms the insulation material. The conductor is the segmented copper conductor insulated by extruded XLPE layers. The insulation material is suitable for a conductor temperature of 90°C and a short-circuit temperature of 250°C. Although the main application for XLPE cables is the land installation and the offshore industry, XLPE with extruded insulation material for HVDC systems of lower transmission capacities are under development.

2) Lapped Thin Film Insulation

As insulating material a lapped non-impregnated thin PP film is used instead of the impregnated materials. The tests for the cable itself are completed. Now the tests for the accessories such as joints are under process.

This type of cable can sustain up to 60% higher electrical stresses in operation, making it suitable for very long and deep submarine cables.

Another area of development are the cable arrangements. For monopolar transmission systems, either the return path was the ground ('ground return') or a second cable. The first solution always provokes environmental concerns whereas the second one has excessive impact on the costs for the overall transmission scheme.

Therefore, a new cable was developed with an integrated return conductor. The cable core is the traditional design for a mass-impregnated cable and the return conductor is wound outside the lead sheath. The conductor forms also part of the balanced armour, together with the flat steel wire layer on the outside of the return conductor insulation.

This cable type was installed between Scotland and Northern Ireland for 250 kV and 250 MW. R&D is ongoing to increase the voltage as well as the capacity of the cable with integrated return conductor.

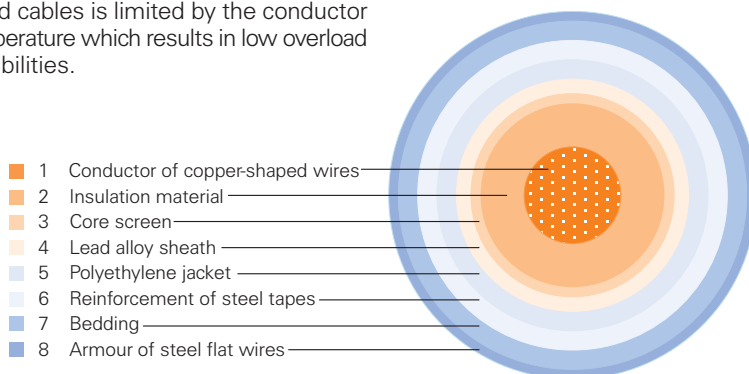

Fig. 5.6.2.2-1: Mass-impregnated cable



## 5.6.3 High Speed DC Switches

### 5.6.3.1 General

Like in AC substations, switching devices are also needed in the DC yard of HVDC stations. One group of such devices can be characterized as switches with direct current commutation capabilities, commonly called "high-speed DC switches".

Siemens standard SF<sub>6</sub> AC circuit-breakers of proven design are able to meet the requirements of high-speed DC switches.

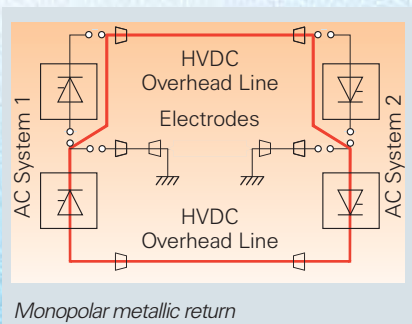
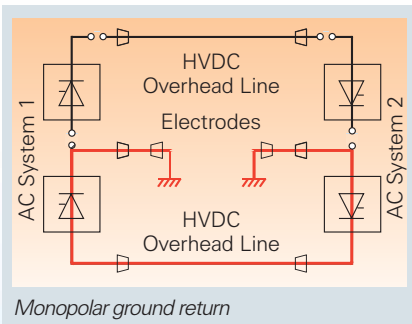
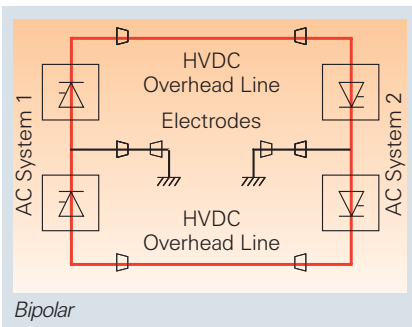

Fig. 5.6.3-1: HVDC system configurations

### 5.6.3.2 Types and Duties of the High-Speed DC Switches

Type	Duties
<b>HSNBS</b> ( <u>H</u> igh- <u>S</u> peed <u>N</u> eutral <u>B</u> us <u>S</u> witch)	The HSNBS must commutate some direct current into the ground electrode path in case of faults to ground at the station neutral.
<b>HSGS</b> ( <u>H</u> igh- <u>S</u> peed <u>G</u> round <u>S</u> witch)	The HSGS is needed to connect the station neutral to the station ground grid if the ground electrode path becomes isolated.
<b>MRTB</b> ( <u>M</u> etallic <u>R</u> eturn <u>T</u> ransfer <u>B</u> reaker)	If one pole of a bipolar system has to be blocked, monopolar operation of the second pole is achieved automatically, but with return current through ground (refer to Fig. 5.6.3-1). If the duration of ground return operation is restricted, an alternate mode of monopolar operation is possible if the line of the blocked pole can be used for current return. This mode is called metallic return (refer to Fig. 5.6.3-1). The MRTB is required for the transfer from ground to metallic return without interruption of power flow.
<b>GRTS</b> ( <u>G</u> round <u>R</u> eturn <u>T</u> ransfer <u>S</u> witch)	The GRTS is needed for the retransfer from metallic return to bipolar operation via ground return, also without interruption of power flow.

MRTB at Tian Guang/China DC switchyard



### 5.6.3.3 Design Considerations

Details regarding the duties of "HSNBS" and "HSGS" are not discussed here but the more severe requirements for "MRTB" and "GRTS" are explained.

Fig. 5.6.3-2 shows the disposition of MRTB and GRTS.  $I_3$  may reach values of up to 90% of the total current  $I_0$  and  $I_4$  values of up to 25% of  $I_0$ .

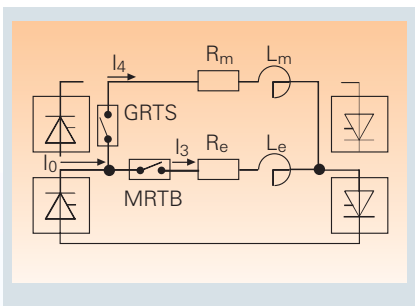

Fig. 5.6.3-2: Equivalent circuit relevant to MRTB and GRTS operation

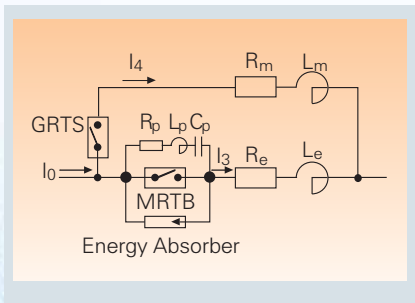

Fig. 5.6.3-3: Details of the MRTB circuit

The ground resistance  $R_e$  is normally much lower than the metallic resistance  $R_m$ . Therefore, during the transitional steady-state condition with both MRTB and GRTS closed, most of the current is flowing through ground which determines the commutation requirements for MRTB and GRTS.  $I_3$  may reach values of up to 90% of the total current  $I_0$  and  $I_4$  values of up to 25% of  $I_0$ . The following considerations refer to MRTB only. From the above it can be concluded that the commutation duties for transfer from ground to metallic return (MRTB) are much heavier than from metallic to ground return (GRTS).

Fig. 5.6.3-3 shows the basic MRTB circuit. An energy absorber and the  $L_p C_p$  resonant circuit ( $R_p$  represents the ohmic resistance of that branch only) are connected in parallel to the main switch (MRTB) which is a conventional SF<sub>6</sub>-type AC breaker.

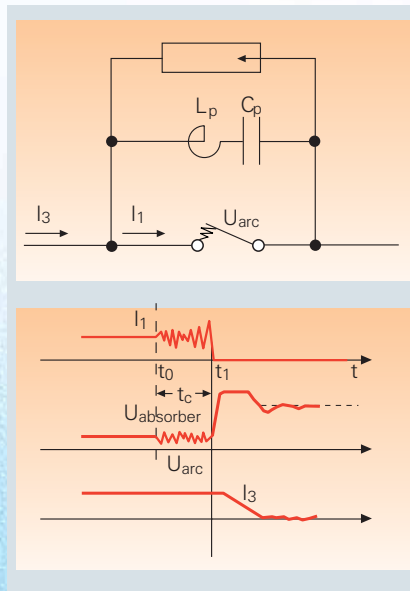

Fig. 5.6.3-4: Principles of MRTB operation

With reference to Fig 5.6.3-4, the principle of commutation is as follows: At  $t_0$ , the contacts of the breaker separate, thereby introducing an arc into the circuit. The characteristic of this arc sets up an oscillatory current (frequency determined by  $L_p C_p$ ) which is superimposed on the current  $I_1$ . As  $R_p$  is very small, the oscillation is not damped but increases. As soon as the current  $I_1$  passes through zero (refer to  $t_1$  in Fig. 5.6.3-4), the breaker current is interrupted.  $I_3$ , however, remains unchanged now charging the capacitor  $C_p$  until it reaches a voltage limited by the energy absorber. This voltage acts as a counter voltage to reduce the current  $I_3$  and to increase the current  $I_4$  (refer to Fig. 5.6.3-4 and Fig. 5.6.3-3). When the absorber limiting voltage has been reached, the current  $I_3$  flows into the absorber which dissipates an amount of energy determined by the counter voltage to bring  $I_3$  to zero. When  $I_3$  has dropped to zero,  $I_4$  equals  $I_0$  and the current commutation from ground to metallic return has been completed. It should be noted that the current  $I_0$  of the system (refer to Fig. 5.6.3-2) did not change, i.e. the power transmission was never interrupted.

There are also MRTB principles other than the explained one which are based on complex resonant circuits, externally excited with additional auxiliary power sources. With respect to reliability and availability, the advantage of the above principle with passive resonant circuit which is used by Siemens is quite evident. The nozzle system and specifically the flow of SF<sub>6</sub> gas in the Siemens standard SF<sub>6</sub> AC breakers result in an arc characteristic which ensures reliable operation of the passive resonant circuit. One unit of a standard three-phase AC breaker is used. Extensive series of laboratory tests have shown the capabilities of Siemens SF<sub>6</sub> breakers for this application. Furthermore, such switches are successfully in operation in various HVDC schemes.

## 5.6.4 Earth Electrode

### 5.6.4.1 Function of the Earth Electrode in the HVDC System

Earth electrodes are an essential component of the monopolar HVDC transmission system, since they carry the operating current on a continuous basis. They contribute decisively to the profitability of low-power HVDC systems, since the costs for a second conductor (with half the nominal voltage) are significantly higher, even for transmission over short distances, than the costs for the earth electrodes.

Earth electrodes are also found in all bipolar HVDC systems and in HVDC multi-point systems. As in any high-voltage system, the power circuit of the HVDC system requires a reference point for the definition of the system voltage as the basis for the insulation coordination and overvoltage protection. In a bipolar HVDC system, it would conceivably be possible to connect the station neutral point to the ground mat of the HVDC station to which the line-side star points of the converter transformers are also connected. But since the direct currents in the two poles of the HVDC are never absolutely equal, in spite of current balancing control, a differential current flows continuously from the station neutral point to ground. It is common practice to locate the grounding of the station neutral point at some distance (10 to 50 kilometres) from the HVDC station by means of special earth electrodes.

### 5.6.4.2 Design of Earth Electrodes

Earth electrodes for HVDC systems may be land, coastal or submarine electrodes. In monopolar HVDC systems, which exist almost exclusively in the form of submarine cable transmission systems, there are fundamental differences between the design of anode and cathode electrodes.

#### 5.6.4.2.1 The Horizontal Land Electrode

If a sufficiently large area of flat land with relatively homogeneous ground characteristics is available, the horizontal ground electrode is the most economical form of a land electrode.

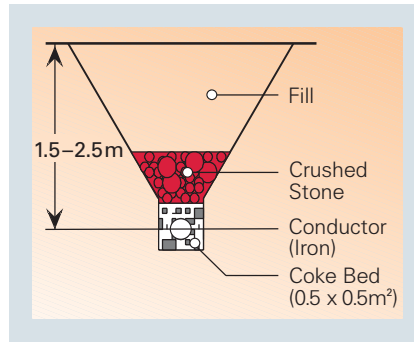

Fig. 5.6.4-1: Cross section through a horizontal land electrode

As shown in figure 5.6.4-1, the electrode conductor itself, which is generally made of iron, is laid horizontally at a depth of approximately 2 m. It is embedded in coke which fills a trench having a cross section of approximately 0.5 x 0.5 m<sup>2</sup>.

The advantage of this design becomes apparent in anodic operation. The passage of the current from the electrode conductor into the coke bed is carried primarily by electrons, and is thus not associated with loss of the material.

Several typical patterns of horizontal land electrodes are illustrated in figure 5.6.4-2

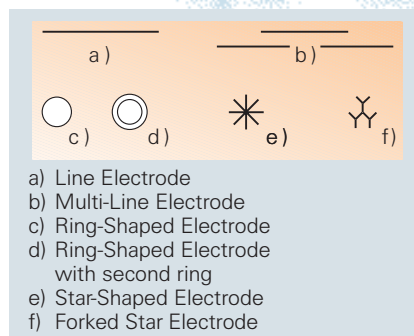

Fig. 5.6.4-2: Plan view of a typical design of horizontal land electrodes

#### 5.6.4.2.2 Vertical Land Electrode

If the ground strata near the surface have a high specific resistance, but underneath, there is a conductive and sufficiently thick stratum at a depth of several tens of meters, the vertical deep electrode is one possible solution.

Figure 5.6.4-3 shows, as an example, one of the four deep electrodes at Apollo, the southern station of the Cahora Bassa HVDC system.

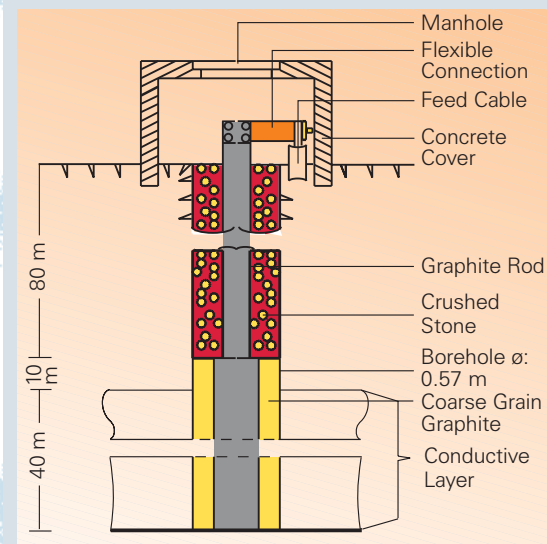

Fig. 5.6.4-3: Vertical electrode at Apollo, the Southern Cahora Bassa HVDC station



### 5.6.4.2.3 Cathodic Submarine Electrodes

The design and construction of the cathodic submarine electrodes of a monopolar HVDC system with submarine power transmission cable do not present any particular problems. Since there is no material corrosion, a copper cable laid on the bottom should theoretically suffice. The length of the cable must be designed so that the current density on its surface causes an electrical field of  $< 3\text{ V/m}$  in the surrounding water, which is also safe for swimmers and divers.

### 5.6.4.2.4 Anodic Submarine Electrodes

Figure 5.6.4-4 shows an example of a linear submarine electrode for anodic operation. The prefabricated electrode modules are lowered to the ocean floor and then connected to the feed cable. When the submarine electrodes are divided into sections which are connected to the HVDC station by means of separate feed cables, the electrode can be monitored from the land.

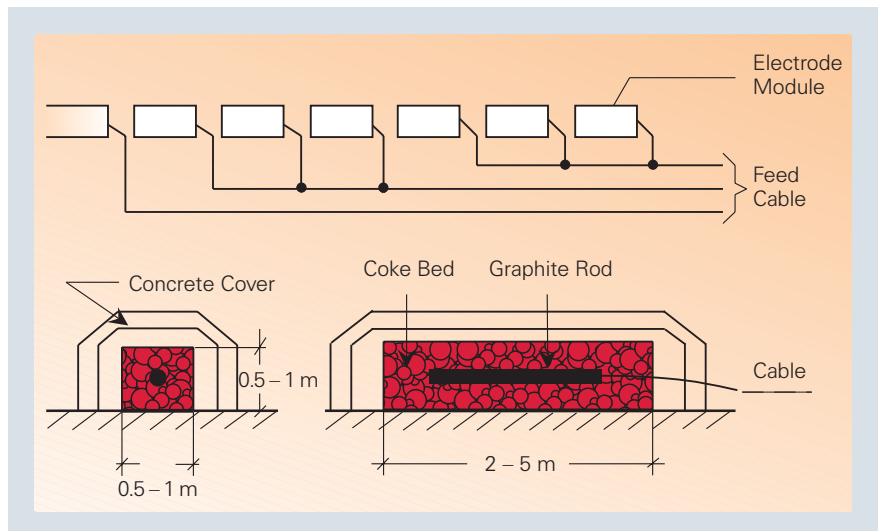

Fig. 5.6.4.-4: Linear submarine electrode (anodic operation)

### 5.6.4.2.5 Anodic Coastal Electrode

The conventional design of a coastal electrode is similar to that of a vertical land electrode. Graphite rods surrounded by a coke bed are installed in boreholes which are sunk along the coastline.

The advantage of the coastal electrodes is easy accessibility for inspection, maintenance and regeneration, if necessary.

A coastal electrode can also be configured in the form of a horizontal land electrode if the ground has the necessary conductivity or if the necessary conductivity can be achieved by irrigating the trench with salt water. In either case, it is assumed that even with a coastal electrode, the current flow to the opposite electrode takes place almost exclusively through the water.

# 5.7 Control & Protection

## 5.7.1 General

The WIN-TDC Control and Protection System plays an important role in the successful implementation of HVDC transmission systems. High reliability is guaranteed with a redundant and fault tolerant design. Flexibility (through choice of optional control centres) and high dynamic performance were the prerequisites for the development of our control and protection system. Knowledge gained from over 30 years of operational experience and parallel use of similar technology in related fields has been built into the sophisticated technology we can offer today.

Main objectives for the implementation of the HVDC control system are reliable energy transmission which operates highly efficient and flexible energy flow that responds to sudden changes in

demand thus contributing to network stability.

All WIN-TDC components from the Human Machine Interface (HMI) workstations, the control and protection systems down to the state of the art measuring equipment for DC current and voltage quantities have been upgraded to take advantage of the latest software and hardware developments. These control and protection systems are based on standard products with a product life cycle for the next 25 years.

The control is divided into the following hierarchical levels:

- Operator control level (WIN CC)
- Control and protection level (SimaticTDC)
- Field level (I/Os, time tagging, interlocking)

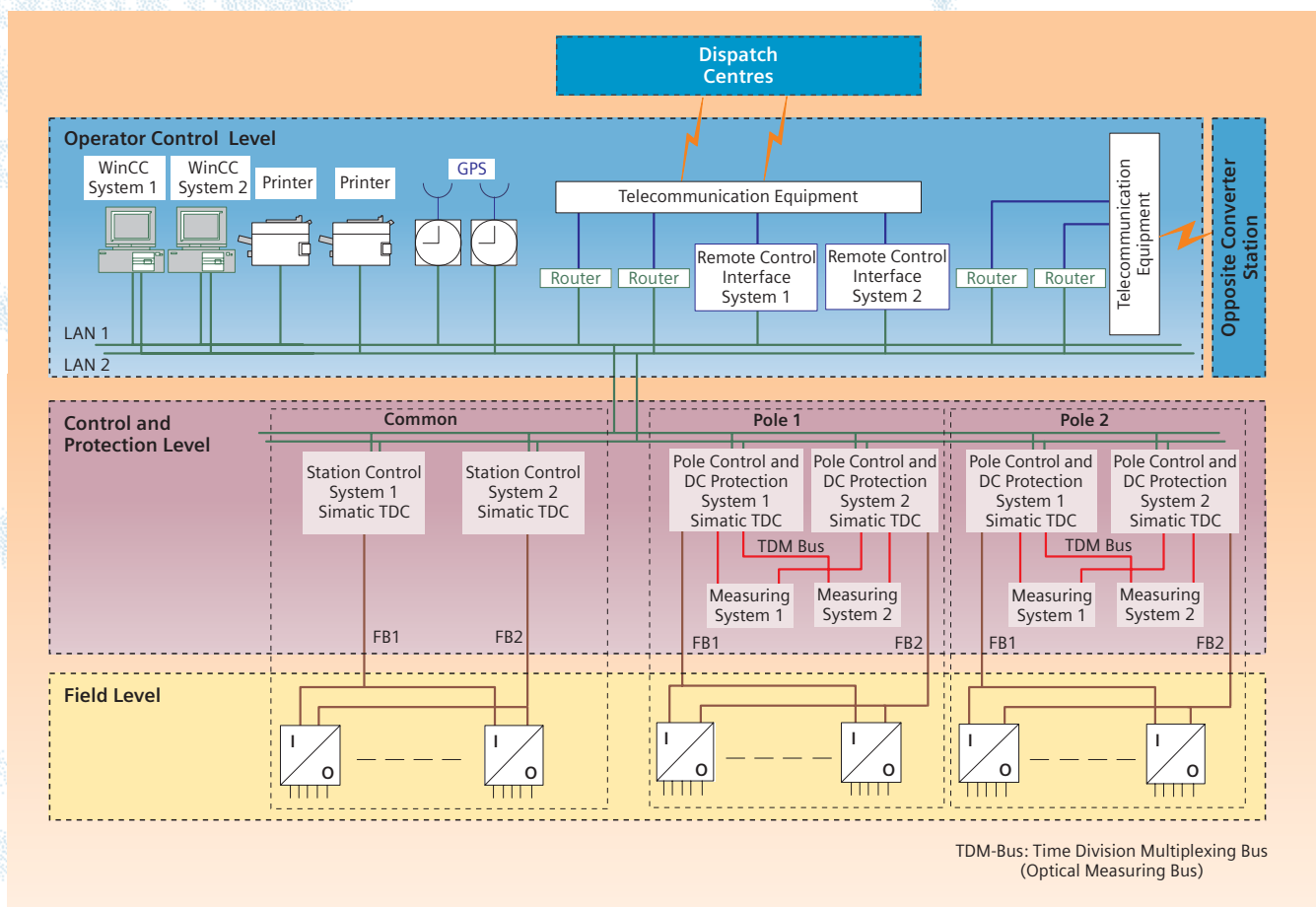

Fig. 5.71-1: HVDC control hierarchy, one station (bipolar HVDC transmission scheme)



In the following section, functions, tasks and components are described to provide an overview.

#### 5.7.1.1 High Availability

The main design criteria for Siemens HVDC systems is to achieve maximum energy availability. This applies to the design of the control and protection systems as well. A single fault of any piece of equipment in the control and protection systems may not lead to a loss of power. Therefore, the primary control and protection components are configured as redundant systems.

#### 5.7.1.2 Self-Testing Features

All control and protection systems are equipped with self-diagnostic features that allow the operator to quickly identify and replace the defective part to recover redundancy as soon as possible.

#### 5.7.1.3 Low Maintenance

With today's digital systems there is no requirement for routine maintenance. However, should it be necessary to replace single modules, the design is such that there is no operational impact on the HVDC system. This is achieved by designing all primary components as redundant systems, where one system can be switched off without impact on the other system.

#### 5.7.1.4 Best Support – Remote Access

As an optional feature, the control system can be accessed remotely via point-to-point telephone connection or via Internet. This allows remote plant monitoring and fault detection including diagnostics. To ensure the data security, a VPN (Virtual Private Network) encrypted connection is used. Furthermore, a password protected access ensures that only authorized personnel have access.

With the use of a standard web browser, main diagnosis data can be monitored. Expert access to the control components is also possible. This remote access feature provides flexible support for the commissioning and maintenance personnel by our design engineers.

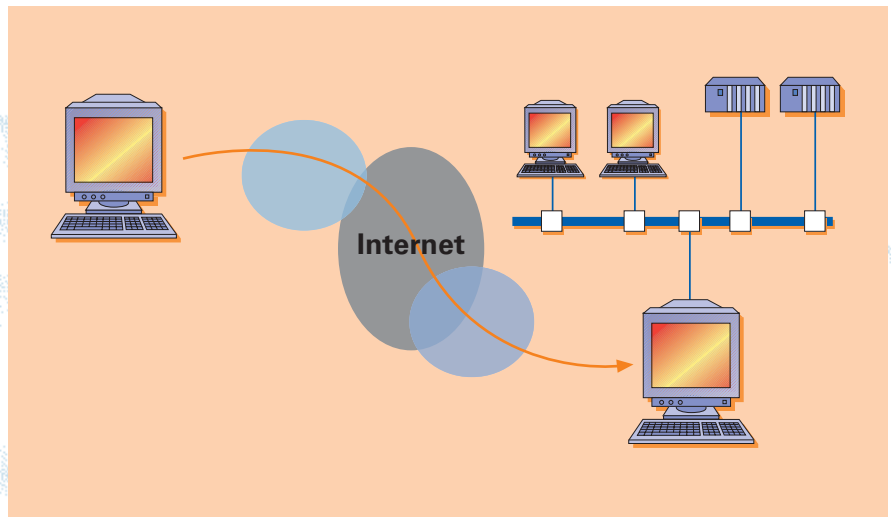

Fig. 5.7.1-2: Remote access connection

#### 5.7.1.5 Modular Design

The control and protection systems use multiprocessor hardware. This means that the computing capacity can be scaled according to the requirements.

Therefore, the most economic solution can be found at the start. Additional computing capacity can be added at any time later, if required.

#### 5.7.1.6 Communication Interfaces

The control and protection systems as well as the operator control system communicate via Ethernet or Profibus. For remote control interfacing, a number of standard protocols are available. Custom protocols can be implemented as an option.

# 5.7 Control & Protection

## 5.7.2 Control Components

### 5.7.2.1 Operator Control System

The tasks of a modern operation and monitoring system within the HVDC control system include the following:

- Status information of the system
- Operator guidance to prevent maloperation and explain conditions
- Monitoring of the entire installation and auxiliary equipment
- Graphic display providing structural overview of the entire system

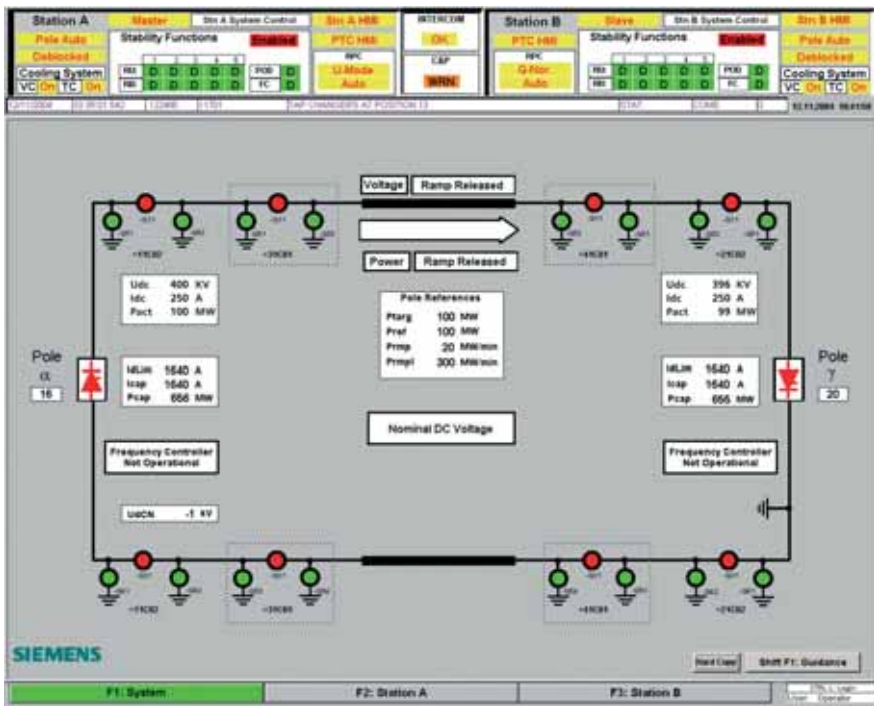

Fig. 5.7.1-3: Operator workstation, typical screen layout for a monopolar HVDC system overview

- Troubleshooting support with clear messages to quickly resume operation
- Display and sorting of time tagged events (time is synchronised via GPS clock)
- Display and archiving of messages
- Automatic generation of process reports

WinCC™ Alarm Logging - RT - Sequence archive report							
Copyright © 1995-2001 by SIEMENS AG							
\\WINCCPC101\WinCC50_Project_XYZ\XYZ.mcp							
Date	Time	Number	Device	Message text	Class	Status	Duration
04/11/04	14:56:26.576	224297	21VR01-AIDCP	TRAVELLING WAVEFRONT WFPOLREC REQ	WRN	COME	0:00:00
04/11/04	14:56:26.577	224297	21VR02-AIDCP	TRAVELLING WAVEFRONT WFPOLREC REQ	WRN	COME	0:00:00
04/11/04	14:56:26.581	124297	11VR01-AIDCP	TRAVELLING WAVEFRONT WFPOLREC REQ	WRN	COME	0:00:00
04/11/04	14:56:26.591	224297	21VR01-AIDCP	TRAVELLING WAVEFRONT WFPOLREC REQ	WRN	GO	0:00:00
04/11/04	14:56:26.592	124807	11VR02-AIDCP	TRAVELLING WAVEFRONT WFPOLREC REQ	WRN	COME	0:00:00
04/11/04	14:56:26.593	224297	21VR02-AIDCP	TRAVELLING WAVEFRONT WFPOLREC REQ	WRN	GO	0:00:00
04/11/04	14:56:26.597	124297	11VR01-AIDCP	TRAVELLING WAVEFRONT WFPOLREC REQ	WRN	GO	0:00:00
04/11/04	14:56:26.598	124807	11VR01-AIDCP	TRAVELLING WAVEFRONT WFPOLREC REQ	WRN	GO	0:00:00
04/11/04	14:56:26.591	123955	11VR00	DC LINE FAULT	WRN	COME	0:00:00
04/11/04	14:56:26.631	104340	11XJ00	AC FILTER OFF INHIBIT BY HARMONIC PERF	STAT	GO	0:13:36
04/11/04	14:56:26.690	224402	21VR01-AIDCP	LINE FAULT LOCATION OVERHEAD LINE	INFO	COME	0:00:00
04/11/04	14:56:26.691	225122	21VR02-AIDCP	LINE FAULT LOCATION OVERHEAD LINE	INFO	COME	0:00:00
04/11/04	14:56:26.693	124402	11VR01-AIDCP	LINE FAULT LOCATION OVERHEAD LINE	INFO	COME	0:00:00
04/11/04	14:56:26.693	125122	11VR02-AIDCP	LINE FAULT LOCATION OVERHEAD LINE	INFO	COME	0:00:00
04/11/04	14:56:26.691	104340	11XJ00	AC FILTER OFF INHIBIT BY HARMONIC PERF	STAT	GO	0:13:36
04/11/04	14:56:26.707	223955	21VR00	FREQUENCY CONTROL ACTIVE	STAT	COME	0:00:00
04/11/04	14:56:26.749	224402	21VR01-AIDCP	LINE FAULT LOCATION OVERHEAD LINE	INFO	GO	0:00:00
04/11/04	14:56:26.751	225122	21VR02-AIDCP	LINE FAULT LOCATION OVERHEAD LINE	INFO	GO	0:00:00
04/11/04	14:56:26.756	124402	11VR01-AIDCP	LINE FAULT LOCATION OVERHEAD LINE	INFO	GO	0:00:00
04/11/04	14:56:26.757	125122	11VR02-AIDCP	LINE FAULT LOCATION OVERHEAD LINE	INFO	GO	0:00:00
04/11/04	14:56:26.792	100015	21001+061	TFR IS RECORDING	STAT	COME	0:00:00
04/11/04	14:56:26.821	100015	11001+061	TFR IS RECORDING	STAT	COME	0:00:00
04/11/04	14:56:26.836	223955	21VR00	DC LINE FAULT	WRN	GO	0:00:00
04/11/04	14:56:26.840	123955	11VR00	DC LINE FAULT	WRN	GO	0:00:00
04/11/04	14:56:27.017	104340	11XJ00	AC FILTER OFF INHIBIT BY HARMONIC PERF	STAT	COME	0:00:00
04/11/04	14:56:27.075	104340	11XJ00	AC FILTER OFF INHIBIT BY HARMONIC PERF	STAT	COME	0:00:00
04/11/04	14:56:27.439	104346	11XJ00	AC FILTER OFF INHIBIT BY U-LIMITATION	WRN	COME	0:00:00
04/11/04	14:56:27.775	104346	11XJ00	AC FILTER OFF INHIBIT BY U-LIMITATION	WRN	GO	0:00:00
04/11/04	14:56:51.927	100015	21001+061	TFR IS RECORDING	STAT	GO	0:00:25
04/11/04	14:56:51.961	100015	11001+061	TFR IS RECORDING	STAT	GO	0:00:25

Fig. 5.7.1-4: Sequence of events recording (SER), report layout for SER information



- Analysis of operating mode based on user-defined and archived data (trend system)
- Generation of process data reports



Fig. 5.7.1-5: Trend system, example for trend display

### 5.7.2.2 Control and Protection System Level

The primary tasks in this level are:

- Measuring
- Control of Power Transmission
- Protection

#### Measuring

DC values are measured by means of the hybrid optical DC measuring system. This system measures the voltage drop over a shunt or a voltage divider, converts this voltage into a telegram and transfers it to the measurement cubicle via fibre optics.

The scheme is designed to be completely redundant, therefore loss of a signal does not lead to an impact on power transmission. This measuring principle contributes to an increased availability of the control and protection scheme.

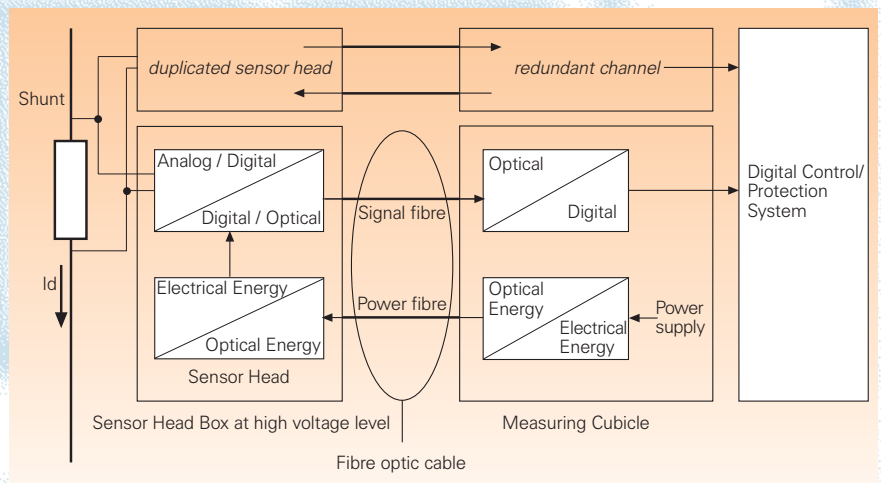

The advantages of such a scheme are:

- Reduced weight (100 kg)
- Linear response (passive system)
- Improved EMC (due to fibre optics)
- Integrated harmonic measurement (Rogowsky coil) for use in active filters or harmonic monitoring schemes.

Fig. 5.7.1-6: Principle of the hybrid optical measuring scheme

# 5.7 Control & Protection

## Control of Power Transmission

The pole control system is responsible for firing the thyristor valves so that the requested power is transmitted. The pole controls on each side of the transmission link therefore have to fulfill different tasks. The pole control system on the rectifier side controls the current so that the requested power is achieved. The pole control system on the inverter side controls the DC voltage so that rated DC voltage is achieved.

The pole control is implemented redundantly. A failure in one system thus has no impact on power transmission.

This system can be repaired while the other system remains in operation. In bipolar schemes a redundant pole control system is assigned to each pole. Failures in one pole will not have any impact on the remaining pole.

## Protection

The DC protection system has the task of protecting equipment and personnel. The protection systems can be divided into two areas, which are subsequently divided into different protection zones.

The HVDC-related protection functions are referred to as DC protection. These include converter protection, DC busbar protection, DC filter protection, electrode line protection and DC line protection.

The AC protection scheme consists mainly of the AC busbar, the AC line and the AC grid transformer protection as well as the AC filter protection and converter transformer protection.

The task of the protective equipment is to prevent damage of individual components caused by faults or overstresses.

Each protection zone is covered by at least two independent protective units – the primary protective unit and the secondary (or back-up) protective unit.

Comprehensive system monitoring and measurement plausibility functions are implemented in the protection systems. This serves to prevent false trips due to singular equipment failure.

The protection functions of the various protective relays are executed reliably for all operating conditions. The selected protective systems ensure that all possible faults are detected, annunciated and cleared selectively.

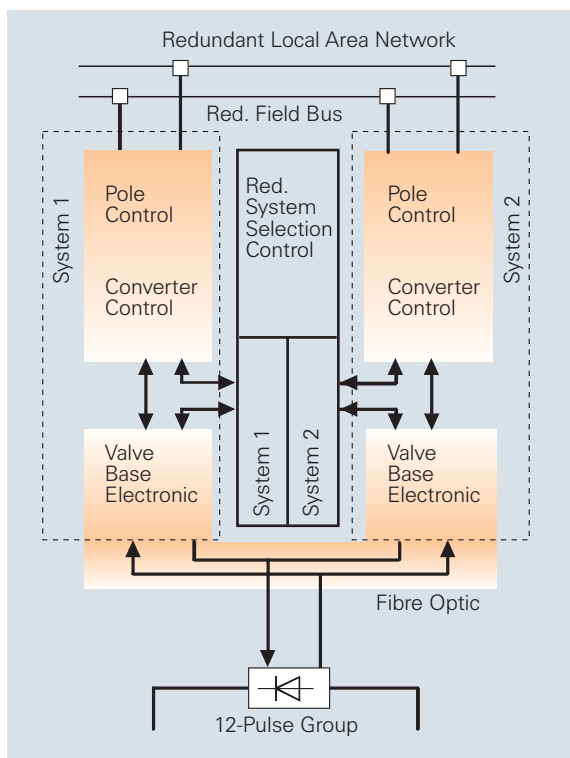

Fig. 5.71-7: Redundant pole control system structure (for one 12-pulse group)

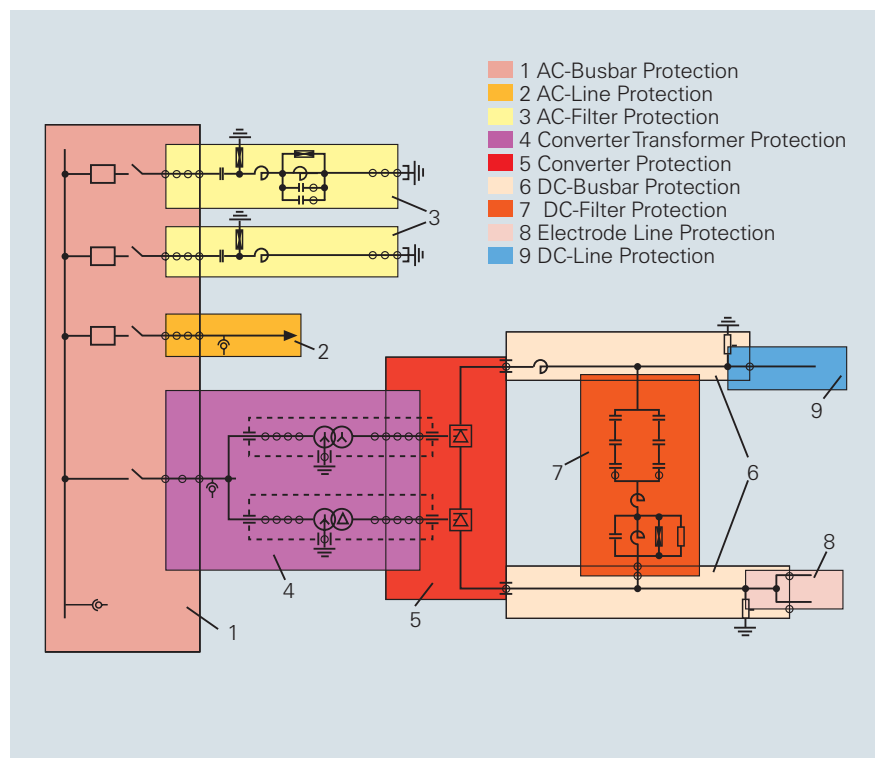

Fig. 5.71-8: Protection zones, one pole/one station



All protective equipment in the HVDC converter station is implemented either with digital multi-microprocessor systems or with digital Siemens standard protective relays. "The DC protection is designed to be fully redundant. Additionally both protection systems incorporate main and back-up protection functions using different principles. The AC protection consists of a main and back-up system using different principles. Each protective system is assigned its own measuring devices as well as power supplies."

### **5.7.3 Control Aspects**

#### **5.7.3.1 Redundancy**

All control and protection systems that contribute to the energy availability are configured redundantly. This covers any single faults in the control and protection equipment without loss of power.

#### **5.7.3.2 Operator Training**

For Siemens HVDC application, an operator training simulator is optionally available. The simulator allows the operator to train with the same hardware and software as in the real process. This simulator consists of the original operator workstation and a simulation PC. The simulation PC runs the HVDC process and feeds the relevant data to the workstation.

#### **5.7.4 Testing and Quality Assurance**

The design process has a number of defined review steps. These allow verification of the control and protection system functionality and performance before delivery to site (see figure 5.71-10).

Already along with the tender, the use of accurate simulation tools allows to answer specific performance issues that are vital to the customer's grid.

#### **5.7.4.1 Offline Simulation EMTDC**

Siemens uses a simulation model that includes all details of control and protection functionality in detail. Thus forecast of real system behaviour is reliable. Therefore it is possible to optimize the application to find the best economic solution while providing the optimum performance.



*Fig. 5.71-9: Real-time simulator*

#### **5.7.4.2 Dynamic Performance Test**

The offline simulation with EMTDC is already an extremely accurate forecast of the real system behaviour. To verify the findings and optimize the controller settings, the control and protection systems are additionally tested during the dynamic performance test with a real-time simulator. During that phase, the customer may witness these performance tests of the final control and protection software.



### 5.7.4.3 Functional Performance Test

In the functional performance test, the dedicated control and protection hardware is installed and tested with a real-time simulator. The purpose of the FPT is to test the proper signal exchange between the various control components as well as the verification of the specified control sequences. This allows optimized commissioning time. Furthermore, customer personnel can participate in this test for operator training and become familiar with the control system.



Fig. 5.71-11: Example of a functional performance test setup

### 5.7.4.4 On-Site Tests

On-site tests are basically divided into test steps regarding the related station (station A, station B) and into the test steps related to the whole HVDC system.

At the precommissioning stage, the base work for commissioning the control system and protection system is required. The main task is preparation and individual testing of any single system.

This is required to assure the systems are free of transportation damage. The next station-related tests are the subsystem tests. Subsystems consist of equipment items which are grouped according to common functions like AC filter banks or thyristor valve systems. The main task is testing the proper function of interconnected systems before switching on high voltage. Following this, station tests with high voltage but no energy transfer will take place. Finally, system and acceptance tests with several operating points of energy transfer will be used for fine tuning and verification of system performance.

Fig. 5.71-10: The main steps for the HVDC control and protection versus the time starting from the contract award up to commercial operation

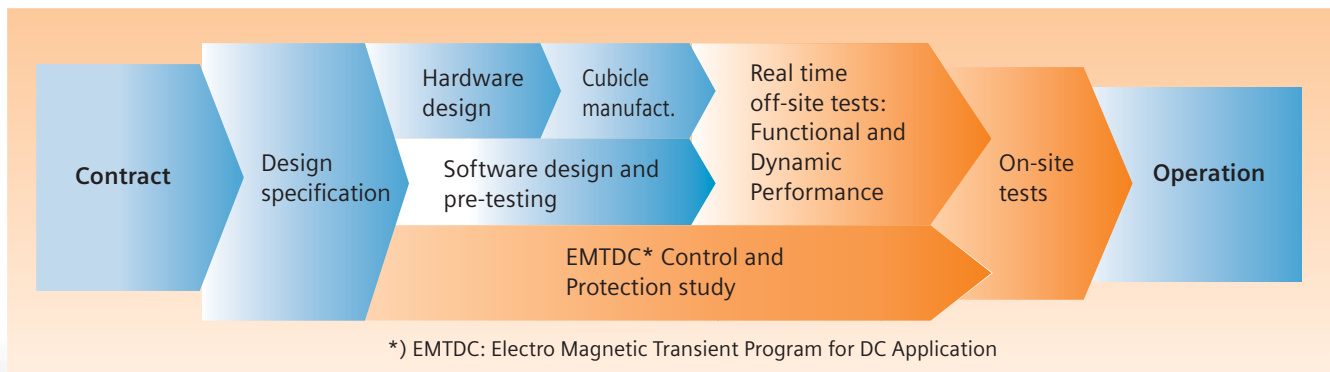



## 6.1 System Studies

During the planning stage of a HVDC project, preliminary studies are carried out in order to establish the basic design of the whole HVDC transmission project. This includes the co-ordination of all relevant technical parts of the transmission system like HVDC converters, AC and DC overhead lines as well as the submarine cable, if applicable.

All specified requirements will be taken into account and are the basis for the preliminary design of the HVDC transmission link. In addition, special attention is paid to improving the stability of both connected AC systems. Several additional control functions like power modulation, frequency control and AC voltage limiter can be included in order to provide excellent dynamic behaviour and to assist the AC systems if the studies show it necessary. Sub-synchronous oscillation will be avoided by special control functions, if required. All the AC system conditions and the environmental conditions as given in the relevant documents will be considered in the design calculations.

The final design of the HVDC transmission system, including the operation characteristics, will be defined during the detailed system studies. All necessary studies are carried out to confirm the appropriate performance requirements and ratings of all the equipment.

Due consideration is given to the interaction with the AC systems on both sides, the generation of reactive power, system frequency variations, overvoltages, short circuit levels and system inertia during all system configurations.

Typically the following studies are carried out:

- a) Main Circuit Parameters
- b) Power Circuit Arrangements
- c) Thermal Rating of Key Equipment
- d) Reactive Power Management
- e) Temporary Overvoltages and Ferro-Resonance Overvoltages
- f) Overvoltage Protection and Insulation Coordination
- g) Transient Current Requirements
- h) AC Filter Performance and Rating
- i) DC Filter Performance and Rating
- j) AC Breaker and DC High-Speed Switch Requirements
- k) Electromagnetic Interference
- l) Reliability and Availability calculations
- m) Loss Calculation
- n) Subsynchronous Resonance
- o) Load Flow, Stability and Interaction between different HVDC Systems
- p) Audible Noise

## 6.2 Digital Models

Digital models of HVDC system can be developed according to the specified requirements. Typically a digital model of dc system is needed for a specific load flow and stability simulation program, while another digital model is required for simulation in a typical electromagnetic transients program such as EMTDC. The functionality and settings of HVDC control and protection system will be represented in a proper manner in such models, which allow suitable simulation of steady state and transient behavior of HVDC system in the corresponding digital programs. Digital models consistent with the actual dc control and protection system are beneficial both for the operation of the HVDC scheme and for the network studies including DC link. Typically such models can be developed on request in the detailed project design stage when all major design works of control and protection functions are completed.

## 6.3 Control and Protection Design Specifications

Design Specifications are written for the control, protection and communication hardware and software. The control panels are then designed, manufactured inspected and tested in accordance to the design specification. The software for the control and protection is also written in accordance to the design specification. It is tested using real time simulators in the dynamic performance test and functional performance test.

Specifications for the topics below are typically written:

- a) General Control and Protection
- b) Interface Systems
- c) Station Control
- d) Diagnosis Systems
- e) Pole Control
- f) HVDC Protection
- g) AC Protection
- h) Metering and Measuring
- i) Operator Control
- j) Communication

# 7 Project Management

## 7.1 Project Management in HVDC Projects

The success and functional completion of large projects depends on the structuring of the project team in accordance with the related work and manpower coordination. Periodical updates and adaptation of design guarantee the execution of the project with constant high quality within the target time frame. Throughout all production, working process and on-site activities, health, safety and environmental protection (HSE) measures as well as application of commonly agreed quality standards such as DIN EN ISO 9001 are of prime importance to Siemens.

### 7.1.1 Division Responsibilities

The overall project is divided and organised according to design activities and technical component groups. These features make it possible to define clear function packages which are to a great extent homogeneous within themselves and can be processed with minimised interfaces.

### 7.1.2 Transparency

A clear process structure plan (PSP) standardised for HVDC projects makes the project contents and sequences transparent in their commercial and technical aspects. Associations and interactions are clarified according to procedure of work.

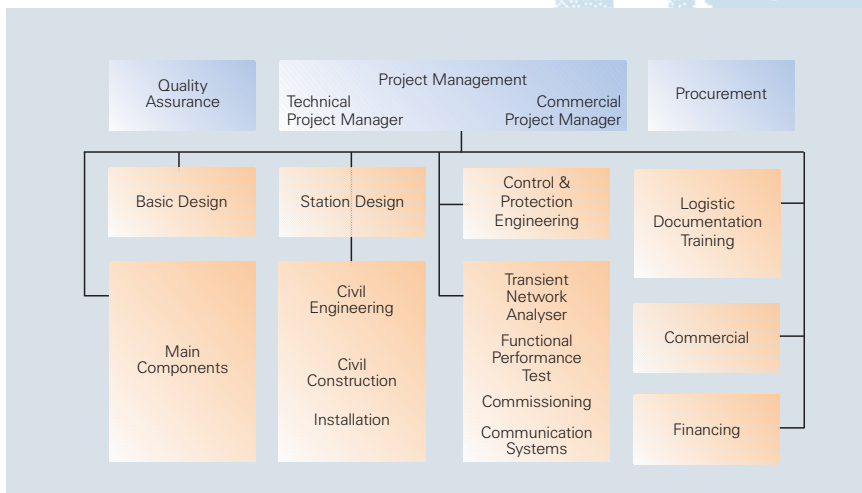

Fig. 7-1: Project organisation plan

### 7.1.3 Risk reduction

Any risks that could arise due to incorrect deadlines, unclear technical concepts or excessive costs will be recognised early enough by a monitoring system so that counter measures can be taken. This increases contract quality and creates the basis for clear design criteria.

### 7.1.4 Progress Report

Periodical meetings with subcontractors, in-house control working teams and customer are recorded in progress reports which form an integral part of the quality insurance system.

### 7.1.5 Scheduling

The hierarchically structured bar-chart schedule is a high-level control tool in project management. The clear structure of sequential processes and parallel activities is crucial for execution of a 24 to 36 month duration, according to the project requirements.

Deadlines for project decisions – especially those of the critical path – can easily be identified enabling the project manager to make up-to date pre-estimates and initiate suitable measures in due time.

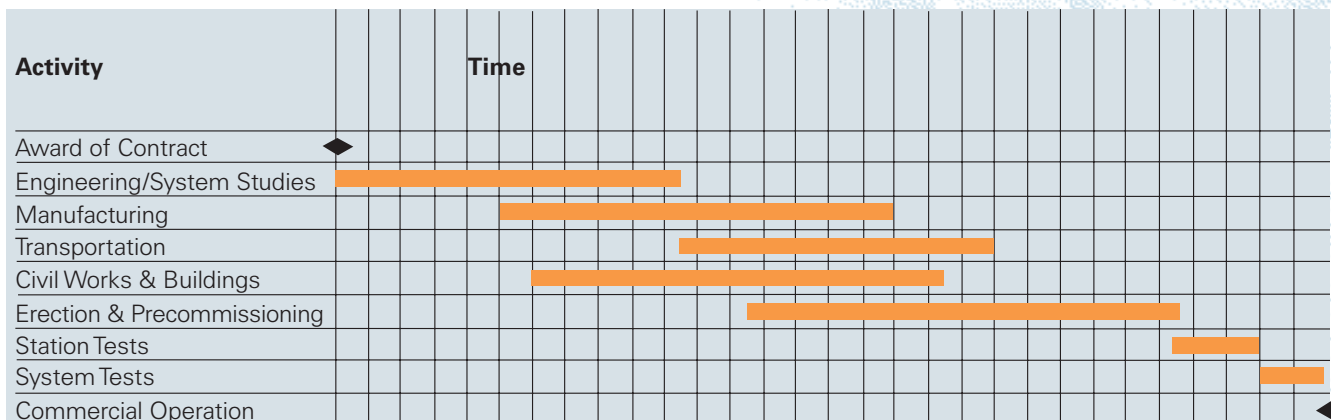

Fig. 7-2: Structured bar-chart timeschedule





# CERTIFICATE

**DQS Deutsche Gesellschaft zur Zertifizierung von Managementsystemen mbH**

hereby certifies that the company

**Siemens AG  
Automation & Drives  
Division Large Drives (A&D LD)**

for the scope

Development, Manufacturing and Sales of  
Electric Machines, Electrical Drive Systems  
High-Voltage Converter Systems and Digital Co

Locations in:

D-13609 Berlin, Nonnendamm  
D-91056 Erlangen, Frauenaur  
D-90441 Nürnberg, Voglwes

and the German A&D Sales Office

has implemented and

**Quality Management**

An audit, documented in a  
quality management system  
of the firm

**DIN**

This certificate  
Certificate  
Frankfurt

*[Signature]*  
Dr. Ing. H. Peter



# ZERTIFIKAT

**DQS Deutsche Gesellschaft zur Zertifizierung von Managementsystemen mbH**  
Dies  
bescheinigt hiermit, dass das Unternehmen

**Siemens AG  
Bereich Energieübertragung und -verteilung  
Geschäftsgebiet Transformatoren und  
Hochspannung**  
Hegestädte 20  
D-73230 Künzern  
Hochenergie Straße 150  
D-90441 Nürnberg

Für den Geltungsbereich:  
Entwicklung, Herstellung und  
Montage sowie Montage

**Qualitäts- und Umweltmanagement**

Durch Audit, dokumentiert  
dieses Managementsystem  
**DIN EN ISO 9001**  
Ausgabe August 2004

**IONet**  
THE INTERNATIONAL CERTIFICATION NETWORK  
**CERTIFICATE**  
DQS GmbH, Chemnitz, Geschäftsstelle zur Zertifizierung von Managementsystemen  
Hierby certifies that the company  
**Siemens AG  
Power Transmission and Distribution  
High Voltage Division**  
D-91056 Erlangen  
has implemented and maintains a  
Quality and Environmental Management System.  
An audit, documented in a  
management system, of the firm  
conforms to the requirements  
of the high voltage standards  
for the scope  
Development, production and sale of product systems and plants  
of all high voltage, energy and high voltage direct current transmission  
equipment and accessories  
for the scope  
Power Transmission and Distribution  
High Voltage Division  
D-91056 Erlangen

**ISO 9001 : 2000 and ISO 14001 : 1996**  
An audit, documented in a  
management system, of the firm  
conforms to the requirements  
of the high voltage standards  
for the scope  
Development, production and sale of product systems and plants  
of all high voltage, energy and high voltage direct current transmission  
equipment and accessories  
for the scope  
Power Transmission and Distribution  
High Voltage Division  
D-91056 Erlangen



**Siemens AG**  
Energy Sector  
High Voltage  
P.O. Box 3220  
91050 Erlangen  
Germany

[www.siemens.com/hvdc](http://www.siemens.com/hvdc)

For more information, contact our  
Customer Support Center.  
Phone: +49 180/524 70 00  
Fax: +49 180/524 24 71  
(Charges depending on provider)  
E-mail: [support.energy@siemens.com](mailto:support.energy@siemens.com)  
[www.siemens.com/energy-support](http://www.siemens.com/energy-support)

Order No. E50001-U131-A92-V3-7600  
Printed in Germany  
Dispo 30000  
TH 263-070877 103017 WS 02081.0