

OPERATOR'S MANUAL

M 337A,AK, M 332A,AK,

M 137A,AZ, M 132A,AK.

AIRCRAFT ENGINES



Manufacturer: **LOM s.p., Praha 10-Malesice, Czech Republic**

Destination: This OPERATOR'S MANUAL is intended for owners, pilots and maintenance personnel responsible for operation and care of aircrafts powered by M 132/332 and M 137/337 series aircraft engines. Beside engine's description and performances, this manual sets forth operation instructions and maintenance procedures.

Piston engines LOM design-date:

7.4. 1998

CAA-CZ date:

21.4.1998

Note.: This is an online copy. By printing or downloading becomes the copy uncontrolled. The user is obliged, before use, to check the official web-page for the latest revision. <http://www.pistovemotory.cz/en/support>

LIST OF REVISIONS

The owner of the manual enters the date, when he performed the change required by the revision. Enter bulletin number only for revisions issued as a bulletin

CHANGE NUMBER	BULLETIN NUMBER	NEW PAGES EDIT. DATE	SECTION NUMBER AFFECTED BY REVISION	REVISION PERFORMED DATE/SIGNATURE
1.	M337AK /12a	12.3.2001	see the list of valid pages	16.5.2001 <i>Johán</i>
2.	n/a	22.05.2018	see the list of valid pages	22.5.2018 <i>Johán</i>

LIST OF VALID PAGES

SECTION	PAGE	DATE	SECTION	PAGE	DATE
Introduction	i	22. 5. 2018		2-16	1. 1. 1998
	ii	22. 5. 2018		2-17	1. 1. 1998
	iii	22. 5. 2018		2-18	1. 1. 1998
	iv	22. 5. 2018		2-19	1. 1. 1998
	v	22. 5. 2018		2-20	1. 1. 1998
	vi	1. 1. 1998		2-21	1. 1. 1998
	vii	12.3.2001		2-22	1. 1. 1998
	viii	1. 1. 1998		2-23	1. 1. 1998
General	1-1	1. 1. 1998		2-24	1. 1. 1998
	1-2	1. 1. 1998		2-25	1. 1. 1998
	1-3	1. 1. 1998		2-26	1. 1. 1998
	1-4	without text		2-27	1. 1. 1998
Description	2-1	1. 1. 1998	Specifications	2-28	1. 1. 1998
	2-2	1. 1. 1998		2-29	1. 1. 1998
	2-3	1. 1. 1998		2-30	1. 1. 1998
	2-4	1. 1. 1998		3-1	1. 1. 1998
	2-5	1. 1. 1998		3-2	1. 1. 1998
	2-6	1. 1. 1998		3-3	1. 1. 1998
	2-7	1. 1. 1998		3-4	1. 1. 1998
	2-8	1. 1. 1998		3-5	1. 1. 1998
	2-9	1. 1. 1998		3-6	1. 1. 1998
	2-10	1. 1. 1998		3-7	12. 3. 2001
	2-11	1. 1. 1998		3-8	1. 1. 1998
	2-12	1. 1. 1998		3-9	1. 1. 1998
	2-13	1. 1. 1998		3-10	1. 1. 1998
	2-14	1. 1. 1998		3-11	1. 1. 1998
	2-15	1. 1. 1998		3-12	1. 1. 1998

SECTION	PAGE	DATE	SECTION	PAGE	DATE	
	3-13	1. 1. 1998		5-9	1. 1. 1998	
	3-14	1. 1. 1998		5-10	1. 1. 1998	
	3-15	1. 1. 1998		5-11	1. 1. 1998	
	3-16	1. 1. 1998		5-12	1. 1. 1998	
	3-17	1. 1. 1998		5-13	12. 3. 2001	
	3-18	1. 1. 1998		5-14	1. 1. 1998	
	3-15	1. 1. 1998		Periodic inspections	6-1	12. 3. 2001
	3-16	1. 1. 1998			6-2	22. 5. 2018
	3-17	1. 1. 1998			6-3	1. 1. 1998
	3-18	1. 1. 1998			6-4	1. 1. 1998
	3-19	1. 1. 1998			6-5	1. 1. 1998
	3-20	1. 1. 1998			6-6	12. 3. 2001
	Operating substances	3-21		1. 1. 1998	6-7	1. 1. 1998
		3-22		1. 1. 1998	6-8	1. 1. 1998
		4-1		1. 1. 1998	6-9	1. 1. 1998
4-2		1. 1. 1998	6-10	22. 5. 2018		
4-3		1. 1. 1998	6-11	1. 1. 1998		
4-4		without text	6-12	1. 1. 1998		
Operation instructions		6-13	12. 3. 2001	6-14	1. 1. 1998	
		5-1	1. 1. 1998	6-15	1. 1. 1998	
	5-2	1. 1. 1998	6-16	1. 1. 1998		
	5-3	1. 1. 1998	6-17	12. 3. 2001		
	5-4	1. 1. 1998	6-18	without text		
	5-5	1. 1. 1998	Maintenance procedures	7-1	1. 1. 1998	
	5-6	12. 3. 2001		7-2	22. 5. 2018	
		5-7	1. 1. 1998			
	5-8	1. 1. 1998				

SECTION	PAGE	DATE	SECTION	PAGE	DATE
	7-3	22. 5. 2018		7-31	1. 1. 1998
	7-4	1. 1. 1998		7-32	1. 1. 1998
	7-5	22. 5. 2018		7-33	1. 1. 1998
	7-6	1. 1. 1998		7-34	1. 1. 1998
	7-7	1. 1. 1998		7-35	1. 1. 1998
	7-8	1. 1. 1998		7-36	1. 1. 1998
	7-9	1. 1. 1998		7-37	1. 1. 1998
	7-10	1. 1. 1998		7-38	without text
	7-11	1. 1. 1998			
	7-12	1. 1. 1998	Trouble-shooting	8-1	1. 1. 1998
	7-13	1. 1. 1998		8-2	22. 5. 2018
	7-14	1. 1. 1998		8-3	1. 1. 1998
	7-15	1. 1. 1998		8-4	1. 1. 1998
	7-16	22. 5. 2018		8-5	1. 1. 1998
	7-17	1. 1. 1998		8-6	1. 1. 1998
	7-18	1. 1. 1998		8-7	1. 1. 1998
	7-19	22. 5. 2018		8-8	1. 1. 1998
	7-20	1. 1. 1998		8-9	22. 5. 2018
	7-21	1. 1. 1998		8-10	1. 1. 1998
	7-22	1. 1. 1998		8-11	1. 1. 1998
	7-23	1. 1. 1998		8-12	without text
	7-24	1. 1. 1998			
	7-25	1. 1. 1998	Shipping,	9-1	1. 1. 1998
	7-26	1. 1. 1998	storage,	9-2	1. 1. 1998
	7-27	1. 1. 1998	installation	9-3	1. 1. 1998
	7-28	1. 1. 1998		9-4	1. 1. 1998
	7-29	1. 1. 1998		9-5	1. 1. 1998
	7-30	1. 1. 1998		9-6	1. 1. 1998

SECTION	PAGE	DATE
	9-7	1. 1. 1998
	9-8	1. 1. 1998
	9-9	1. 1. 1998
	9-10	1. 1. 1998
	9-11	1. 1. 1998
	9-12	1. 1. 1998
	9-13	1. 1. 1998
	9-14	1. 1. 1998
	9-15	1. 1. 1998
	9-16	1. 1. 1998
	9-17	1. 1. 1998
Engine protection and preparation	10-1	1. 1. 1998
	10-2	1. 1. 1998
	10-3	1. 1. 1998
	10-4	1. 1. 1998
	10-5	1. 1. 1998
	10-6	1. 1. 1998
	10-7	1. 1. 1998
	10-8	1. 1. 1998
	10-9	1. 1. 1998
	10-10	1. 1. 1998
Tables	11-1	1. 1. 1998
	11-2	1. 1. 1998
	11-3	1. 1. 1998
	11-4	1. 1. 1998

List of Supplements

1. Aircraft engine M337B supplement No. 1 to Operator's manual M337A,AK,M332A,AK,M137A,AZ,M132A,AK engines.
2. Aircraft engine M337C – supplement No. 2 to Operator's manual M337A,AK,M332A,AK,M137A,AZ,M132A,AK engines.
3. Aircraft engine M332B - supplement No.3 to Operator's manual M337A,AK,M332A,AK,M137A,AZ,M132A,AK engines.

This supplements are binding only for uses of corresponding version of aircraft engines - M337B,M332B,M337C.

TABLE OF CONTENTS

Section 1. GENERAL	1-1
Section 2. DESCRIPTION	2-1
Section 3. SPECIFICATIONS	3-1
Section 4. OPERATING SUBSTANCES	4-1
Section 5. OPERATING INSTRUCTIONS	5-1
Section 6. PERIODIC INSPECTIONS	6-1
Section 7. MAINTENANCE PROCEDURES	7-1
Section 8. TROUBLE-SHOOTING	8-1
Section 9. SHIPPING, STORAGE, INSTALATION	9-1
Section 10. ENGINE PROTECTION AND PREPARATION	10-1
Section 11. TABLES	11-1

SECTION 1
GENERAL

1/ Warning to Operators1-2

2/ Structure of the Manual, Page and Illustration numbering1-2

3/ Manner of Performing Changes in the Manual1-3

4/ Terminology1-3

1. WARNING TO OPERATOR'S

While operating and maintaining the engine, it is unconditionally necessary to observe exactly the prescriptions in this manual. Neglecting to follow the operation instructions or the maintenance procedures, such as other prescriptions contained in different sections of this manual, can result in poor engine performance and power loss. Exceeding engine limitations can determine engine damage and have detrimental influences upon engine life.

The works, required by the maintenance procedures and repair prescriptions in this manual, may only be performed by trained personnel, who meets qualification requirements and is also fully responsible for complete and qualified performed works.

Further information concerning more ample repair procedures, beyond the aim of this manual is contained in the M 337A/AK, M 137A/AZ, M 332A/AK, M132A/AK. engine OVERHAUL MANUAL. Information about assemblies and their part is contained in the SPARE PARTS CATALOGUE of the mentioned engines. Information concerning engine installation is contained in the INSTALLATION MANUAL of the mentioned engines.

2. STRUCTURE OF THE MANUAL

The manual is divided into 11 sections. The number of each page is always composed of two figures separated by a dash. The first figure indicates the ordinal number of the current section, the second figure indicates the ordinal number of the page inside the section. The content of each section is always outlined on the page bearing the ordinal number "n-1" (n for section number).

The illustration numbering is independent for each section and is similar to that of the pages. The numbering begins from 1 upwards and the illustrations are placed inside the text, where they are referred to.

3. MANNER OF PERFORMING CHANGES IN THE MANUAL

Revisions of this manual are issued as bulletins approved by the Aviation Authority i.e. the CIVIL AVIATION AUTHORITY of CZECH REPUBLIC (CAA-CR). The manual's owner will receive a copy of the bulletin with the respective number of affected pages to be replaced and new list of valid pages and revisions. These lists are placed at the beginning of this manual to which they unseparably belong. The revised pages themselves bear a new date of issuance. After receiving the revision and performing the change in his manual, the owner enters the date in the LIST of REVISIONS, when he performed the change, attested by signature.

***Attention:** The owner of the manual is obliged to verify, that the page number and date in his manual correspond to those in the LIST of VALID PAGES. Pages not corresponding to the LIST must be discarded.*

4. TERMINOLOGY

All location references used in this manual are unitary:

- the engine front is the propeller location end.
- the cylinders are numbered in order beginning from the front end, cylinder No. 1 being immediately after propeller.
- the engine right-hand and left-hand sides are designated, viewing the engine from rear. The top and bottom designate locations on engine or part ends considering.
- the rotational sense of drives and accessories is established while viewing from driving side to driven side. The driven instrument sense of rotation is identical to that of its drive.
- the drive ratio is designated by the ratio between the driving part RPM and the driven part RPM. The resulting drive ratio indicates the crankshaft RPM to accessory drive RPM ratio.
- the abbreviation TDC, possibly BDC indicates the top/bottom dead center.

Page without text

SECTION 2

DESCRIPTION

1/ General	2-2
2/ Engine part description	2-2
a/ Crankcase	2-2
b/ Crankshaft	2-2
c/ Connecting rods	2-3
d/ Pistons	2-3
e/ Cylinder barrels and heads	2-3
3/ Valve operating mechanism	2-9
4/ Induction system	2-9
5/ Ignition system	2-20
6/ Oil system	2-22
a/ Pressure oil circuit	2-22
b/ Oil scavenging	2-24
7/ Crankcase venting	2-27
8/ Cooling system	2-27
9/ Engine starting	2-27
a/ Engine equipped with supercharger	2-27
b/ Engine without supercharger	2-27
10/ Accessory drive	2-29
a/ Mechanical RPM indicator drive	2-29
b/ Electrical RPM indicator drive	2-29
c/ Propeller governor drive	2-29
d/ Generator drive	2-29
11/ Engine installation	2-29
12/ Accessories	2-30

1. GENERAL

Models M 132A/AK, M 332A/AK, M 137A/AZ and M 337A/AK are air-cooled, in-line inverted four or six-cylinder engines. The propeller is mounted by means of the propeller flange on the crankshaft bevel end. The engines are equipped with low-pressure injection pump and disengageable centrifugal compressor (applicable for models M 3nn). The valves are actuated by a camshaft supported in the camshaft housings mounted on the cylinder heads. The engines M 132AK, M 332AK, M 137A/AZ, M 337AK (see Fig. 2-1) uses aerobatic oil system enabling high aerobatics, inverted flights included.

2. ENGINE PART DESCRIPTION

A. Crankcase

The crankcase is composed from the proper crankcase, the top lid and the frontal lid. All these parts are magnesium alloy castings. The lids are assembled to the crankcase by means of studs and nuts and using gaskets. The proper crankcase is provided with transversal double walls, where there are located the crankshaft bearings. At the bottom there are other studs for cylinder barrel and head assembling. On the lateral side there are flanges for mounting pin assembly and for generator and RPM transmitter drive. The accessory and vertical shaft drive are located at the rear end. The flanges for supercharger, oil pump and propeller governor mounting are at the rear end too. The flanges for magnetos and oil sump are at the rear end on the bottom side. The top lid is provided with three hanging eyes and with the crankcase breather.

B. Crankshaft

The crankshaft with four/six cranks is forged from special nitrided steel. The main and connecting rod journals are nitrided. All journals are hollow and together with the canals in the crank arms distribute lubricating oil to the connecting rod main bearing. The holes in journals are obturated by means of plate like obturators. The crankshaft frontal end is beveled, with groove for key and threaded for the propeller flange mounting nut. At the crankshaft rear end there are assembled the drive geared wheel and the supercharger drive. The crankshaft is supported on seven slide bearings. The bearings consist of bearing inserts casted from lead

bronze and galvanically lead plated, which are fastened by means of aluminium alloy lids.

C. Connecting rods

The connecting rods, with the stem in the form of "H" section, are aluminum alloy forgings having burnished surface. The bearing cap is retained on the crankshaft end by means of two bolts. Two bearing inserts, cast from lead bronze, are provided on the crankshaft end. The piston pin is mounted directly, without no bearing bushing.

D. Pistons

The pistons are forged from aluminum alloy. Each piston is provided with two compression rings and two oil regulating rings in common grooves. The piston pin is secured against translation by means of elastic retainers. The piston surface is graphite faced.

E. Cylinder barrels and heads

The cylinder barrels are machined from nitrided steel forgings. On the exterior, there are machined cooling fins. The inside of the barrels is nitrided and underwent a special finish to shorten engine run-in period.

The heads, with a great density of cooling fins on the exterior, are aluminum alloy castings. The intake port is on the right side and the exhaust port on the left side. To the heads, with hemispherical combustion chamber, there are shrunk the valve seats made from special steel and the valve guides made from bronze. To the heads there are also screwed in the bronze spark plug inserts. The ports are provided with flanges and studs for air intake piping and exhaust stacks mounting. For camshaft housing mounting, the heads are provided with steel threaded inserts. Each head is provided with one intake and one exhaust valve. The exhaust valve is made from heat-resistant steel and is internally sodium cooled. To actuate valves, there were provided two helical springs, identical for each valve. The upper spring seats are retained by means of tapered keys. The cylinder barrels and heads are mounted together and fastened by means of four studs and nuts. A bronze gasket is placed between the barrel and the head while a thin gasket being placed between cylinder flange and crankcase.

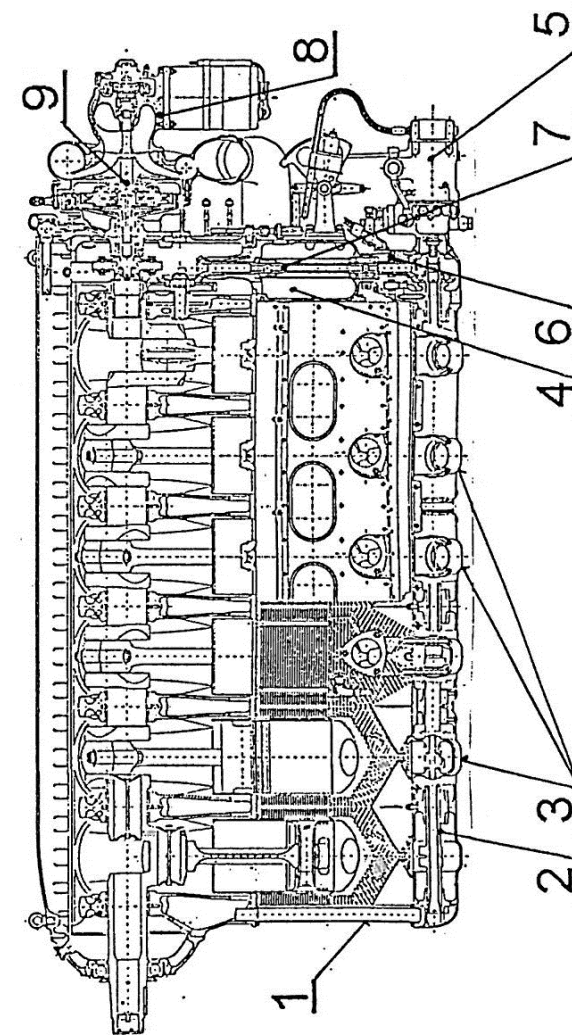

Fig. 2-1 a

Typical M 337AK longitudinal section

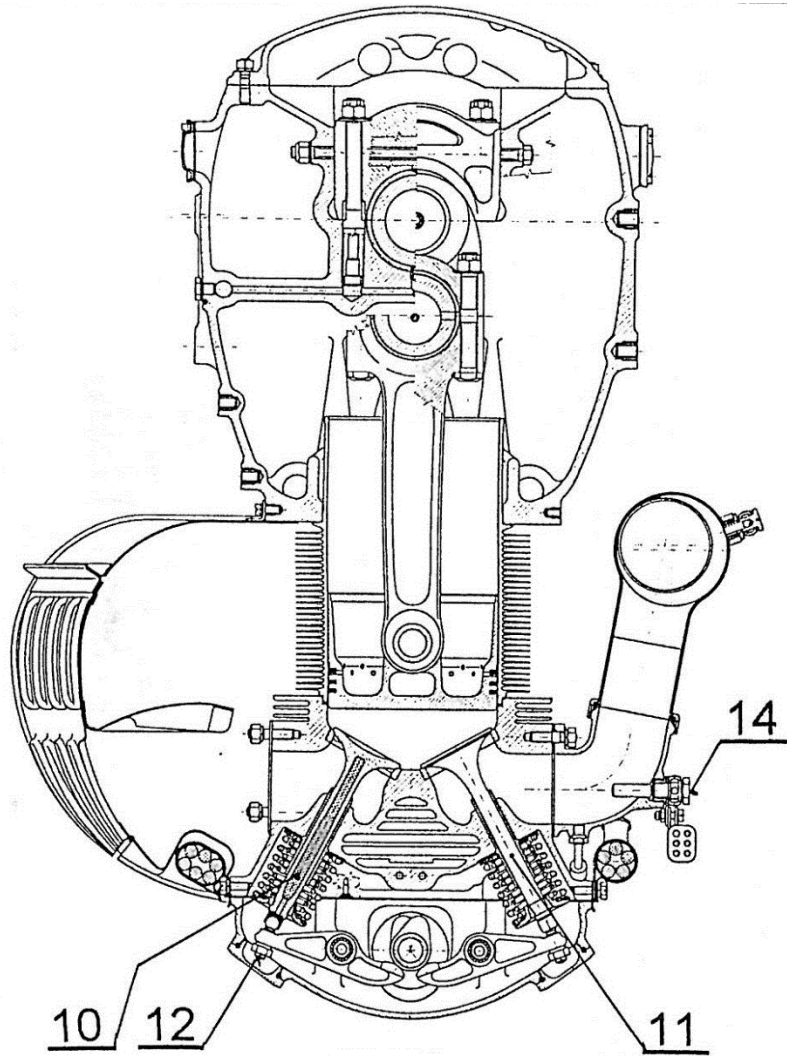

Fig. 2-1 b
Typical M 337A/AK cross section

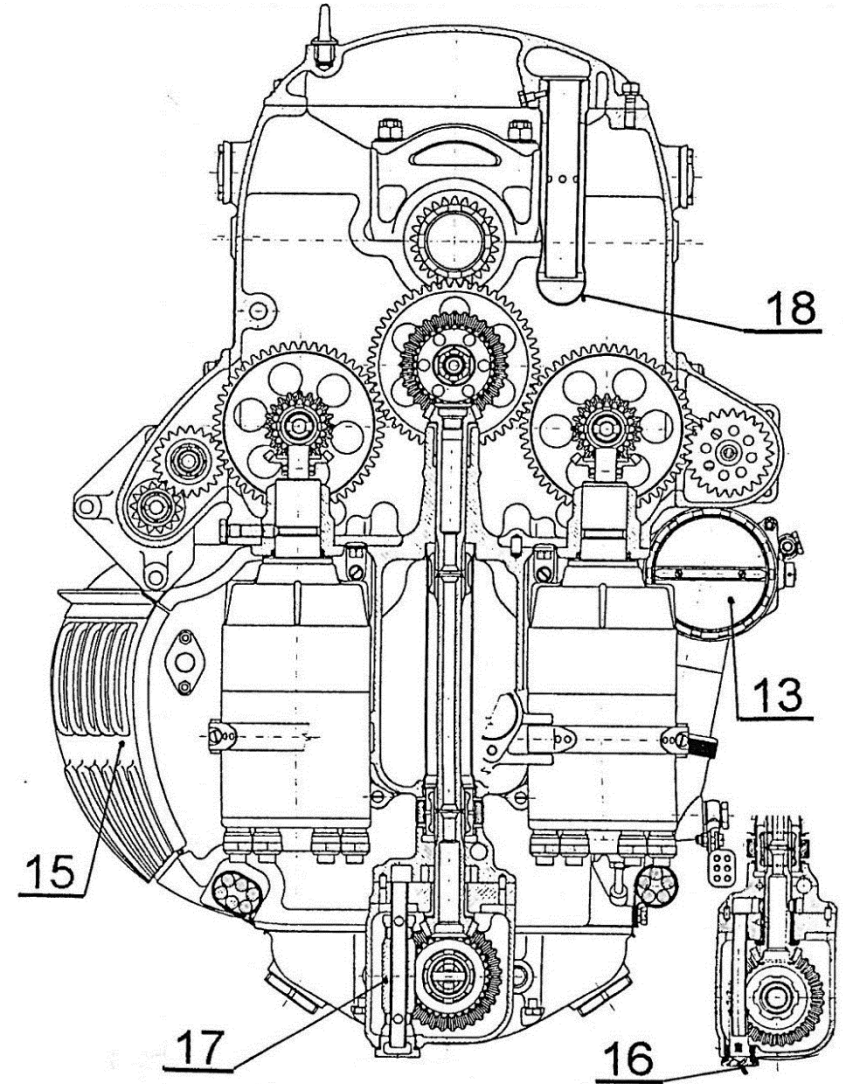
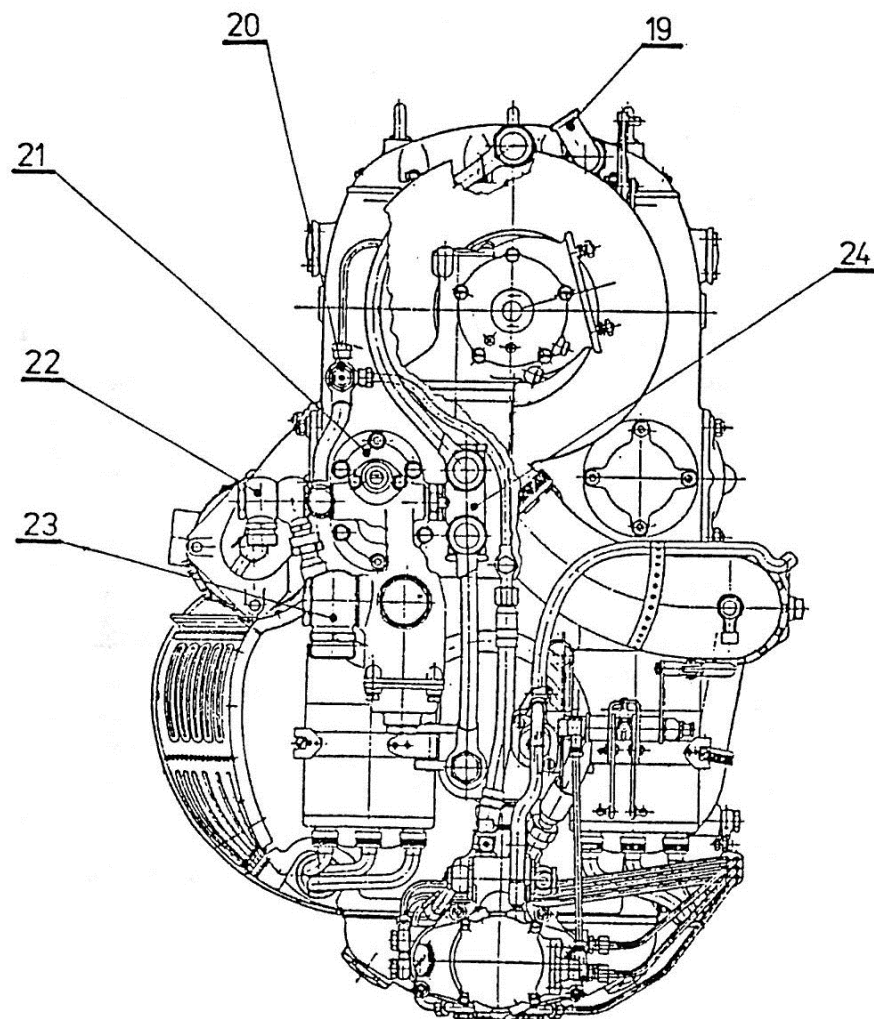

Fig. 2-1 c
Typical M 337A/AK cross section

EXPLANATIONS



1. Crankcase Oil Scavenge Tube
2. Camshaft
3. Camshaft Housings
4. Oil Sump
5. Injection Pump
6. Aux. Oil Scavenge Pump
7. Vertical Shaft
8. Starter
9. Supercharger (M332A,AK; M337A,AK)
10. Exhaust Valve
11. Intake Valve
12. Valve Clearance Adjust Screw
13. Throttle Housing
14. Injection Nozzle
15. Air Scoop
16. M332A, M337A, M132A Oil Strainer
17. Gravity Valve In Camcase M 332AK, M 337AK, M132AK, M137A, M137AZ
18. Crankcase Breather
19. Crankcase Breather
20. Three Way Fitting With High Pressure Valve
21. Main Oil Pump
22. Oil Outlet
23. Oil Inlet
24. Inlet Gravity Valve in Main Oil Pump- M 337AK, M 332AK, M137A/AZ, M132AK

Fig. 2-1 d
M 337 AK rear view

3. VALVE OPERATING MECHANISM

At the crankcase rear end there is the main drive gear solidar with the crankshaft. This gear drives the camshaft over the intermediate gear and the vertical shaft. The camshaft is supported in bearings situated in the three camshaft housings, which are bolted to the cylinder heads. These camshaft housings, one for two heads, are connected by means of centering tubes and rubber sleeves against leaks. The rockers, actuating the valves, are supported in the camshaft housings by means of needle bearings. The rocker camshaft end is provided with a slide contact surface sitting against the cam. The rocker valve end is provided with an adjusting screw, secured in position by means of a safety nut. The adjusting screw serves to adjust valve clearance, after removing the plugs from camshaft housings. The proper matching of the camshaft against the crankshaft succeeds by observing the marks on the gears. These markings should be strictly observed during disassemble and assemble.

4. INDUCTION SYSTEM

The air manifold, made of aluminum alloy sheet, is joined to the air intake piping, fastened to the cylinder heads, by means of magnesium alloy made elbows. The air manifold is also equipped with the throttle housing containing the air throttle itself. The throttle is than connected, by means of a rod, with the main lever from the control cantilever. This cantilever is mounted on the oil sump. The main lever is connected, by means of a rod, with the throttle control in the cockpit.

The engines M 332 and M 337 are equipped with a centrifugal compressor connected, by means of an air conduct, to the air inlet manifold. The compressor is driven, over a geared clutch, from the rear end of the crankshaft. It can be engaged or disengaged over an elastic coupling by means of a control rod situated in the cockpit. This can be achieved during both engine run or stop. The compressor engaging succeeds by braking the exterior geared wheel of the epicyclic gear by means of the belt brake and thereby making the impeller turn with high rotational speed. When the exterior geared wheel is freed, this makes the epicyclic gear function like a geared clutch and thus the impeller turns with the same RPM like the crankshaft. When the engine runs with disengaged compressor, the air is aspirated through the air inlet strainer, the compressor helix and the air manifold to cylinders.

compressed air nor creates resistance for the aspirated air. When engaged, the compressor delivers compressed air to cylinders and thereby the engine performance is increased.

To provide combustion mixture, the engine is equipped with an injection pump. The pump is mounted on the flange at the drive housing and it is driven by the camshaft over a frontal geared wheel. The injection pump is provided with its own fuel pump, which surges fuel from the fuel tank over a fuel strainer and then injects the fuel by means of the nozzles mounted at the air elbows and connected to the injection pump by means of injection fuel lines. The fuel is injected to the air intake before the intake port. A part of the fuel returns to the tank, because of venting reasons. Drain valves are installed at the lower side of the air elbows, to drain the fuel in excess collected during engine start.

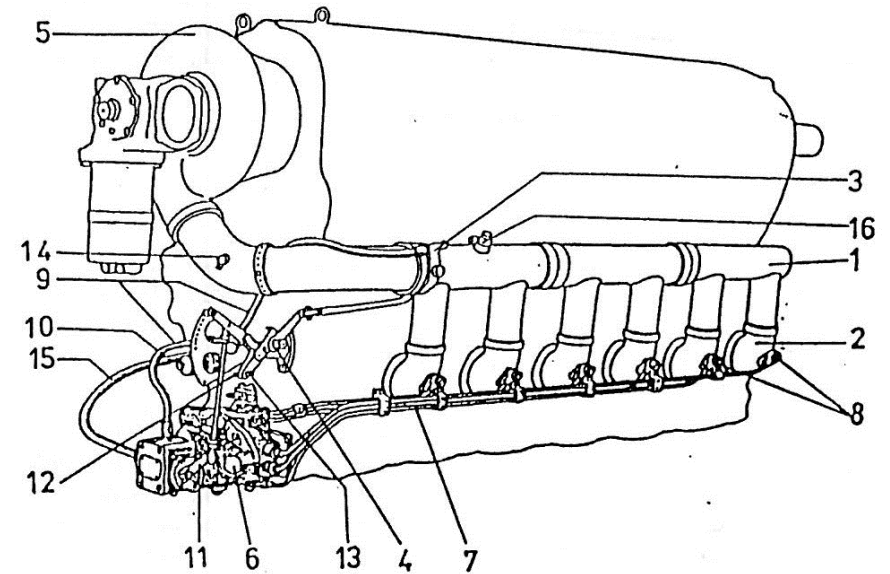

- | | |
|----------------------|--|
| 1-Air Manifold | 9-Correction Hose |
| 2-Air Intake Elbows | 10-Adjusting Screw |
| 3-Throttle Housing | 11-Mixture Lever |
| 4-Control Cantilever | 12-Correction Lever |
| 5-Supercharger | 13-Throttle Lever |
| 6-Injection Pump | 14-Fuel Priming Nozzle |
| 7-Injection Lines | 15-Injection Pump Cooling Hose |
| 8-Injection Nozzles | 16-Manifold Pressure Indicator Fitting |

Fig. 2-2a

Injection pump with manual correction of fuel mixture LUN5150, LUN5150.01, LUN5151.02 – function description – see fig. 2-2b.

The fuel injection pump is an automatically operating device, which doses precisely and distributes the individual doses of fuel into separate engine cylinders within the entire range of engine speed (RPM), correcting simultaneously the richness of fuel mixture according to the oversea altitude up to 800 meters ISA. At a higher flight level the fuel mixture richness must be corrected manually by the mixture control lever (see Section 5).

The fuel injection pump sucks in fuel through an inlet union fitting (1) via an inlet fuel cleaner (2) into a blade fuel delivery pump (3). The fuel delivery pump supplies fuel under a pressure of 0.3 to 0.4 kp/sq.cm into the fuel injection pump deaerating chamber (7). The gases evaporation from fuel are taken together with the returning fuel through a union fitting (9) into the fuel tank. The type has three calibrated holes (8) \varnothing 0.45 in the fuel deaerating chamber (one at the top and two at the bottom) and the fuel return piping provide an escape of fuel gases expelled from the pump by fuel overpressure in any arbitrary position of the engine. The fuel pressure is controlled by a control valve (4), which bypasses the excessive fuel back to the suction space of the fuel delivery pump. The fuel pressure can be controlled by a prestressed spring (5) which presses the valve down into its seat.

The fuel injection pump consists of a pair of plunger pistons (10) which suck fuel through the holes in distributing slide valves (11) and deliver it through the hole in the rotating distributing slide valve (11) into the fuel delivery union fitting (12) of the fuel delivery piping. The pump plunger strokes are variable and are actuated by cams (13) on the face of the fuel pump drive gear wheel. The cam stroke is transferred by a tappet (14) onto a double-arm lever (15) which rests against a control arm (16). The arm changes the lever arm ratio, and thus the plunger stroke as well as the dosing of fuel injected into the engine. The pump plungers are returned back into its initial position by a return spring (17).

The proper mixture ratio depends upon combined action of the injection pump correction and air manifold pressure. The air manifold pressure is caught at the throttle housing and transmitted by means of a rubber hose and through the fuel corrector adjust screw to the fuel injection pump housing (18). The air pressure actuates a set of aneroids, the outer diameter of which is kept in a calibrated bush and when shift a bypass (transfer) plunger piston of the hydraulic servocontrol (20). The plunger piston (20) controls the bypass of pressure oil supplied through

a bypass (transfer) pipe (21) from the drive gear into the hydraulic servocontrol, which consists of cylinder (22), piston (23), muft (24) which shifts the control arm (16). The piston and the bypass plunger piston are returned by return springs (25) and (26).

The automatic device regulating the optimum mixture works up to 800 m ISA (4921, 5 ft). On flights above this elevation the mixture depletes and it is necessary to enrich it manually with increasing elevation. For this reason there is a correcting handle with a scale on the regulating box of the fuel injection pump which is attached to the pull rod on the handle bracket and interconnected with the pilotage in the pilot's cockpit.

After descent to 800 m ISA it is necessary to shift the handle to the basic setting. Manual regulation of the optimum mixture is utilized during engine starting in cold weather.

When the engine is put into operation it is necessary to shift the manual regulation handle to the basic setting—see table 5-1 in section 5.

If the engine oil pressure drops down below 100 kPa, the servocontrol will enrich the fuel injection pump mixture automatically so much that too rich fuel mixture will stop the engine run. The automatic fuel mixture enrichment helps to improve the cold starting of the engine. If the engine is started cold and in a cold weather, the fuel mixture can be enriched more by shifting the fuel mixture hand control lever (27) to a full max. richness, i.e. approx. a triple of the fuel dosing quantity supplied into the engine under normal engine operating (power output) condition. The mixture hand will get displaced and the servocontrol sets up the control arm to maximum fuel supply.

The pressure oil is supplied from the engine through a hole in the flange (28) into the pressure reducing valve (29), which reduces the pressure of engine oil from 350÷400 kPa down to 200 kPa. The reduced pressure oil lubricates the drive gear bearing (30) and the distributing slide valve (11), through which the oil passes into the groove of the fuel injection pump plunger (10). Thus the oil seals the fuel injection pump plunger against seeping of fuel and lubricates it at the same time. The pressure-reduced oil flows further into the hollow space in the drive wheel and through the bypass pipe (21), to the servocontrol mechanism.

The returning oil from bearings and the bypass oil from the servocontrol system is evacuated through a pipe (31), the orifice of which determines the oil level inside the fuel injection pump. The oil is evacuated by a gear oil pump (32), which is driven by the fuel injection pump driving shaft. A back pressure valve (33) prevents the pump from oil over flooding if oil level in the engine is too high. A new pump or a pump after an overhaul is to be filled up with oil through side holes of the pump housing until oil starts to flow out through the oil filling holes. All drives inside the pump casing are actuated by the fuel injection pump driving bladed impeller wheel of the fuel delivery pump (3).

Attention: Any disassembly of fuel injection pump during the operation in the aircraft is prohibited. Also, no disassembly, repeated regulating or replacement of the air nozzle on the corrector (on the handle bracket) which is a part of the device regulating the injection of fuel must be conducted.

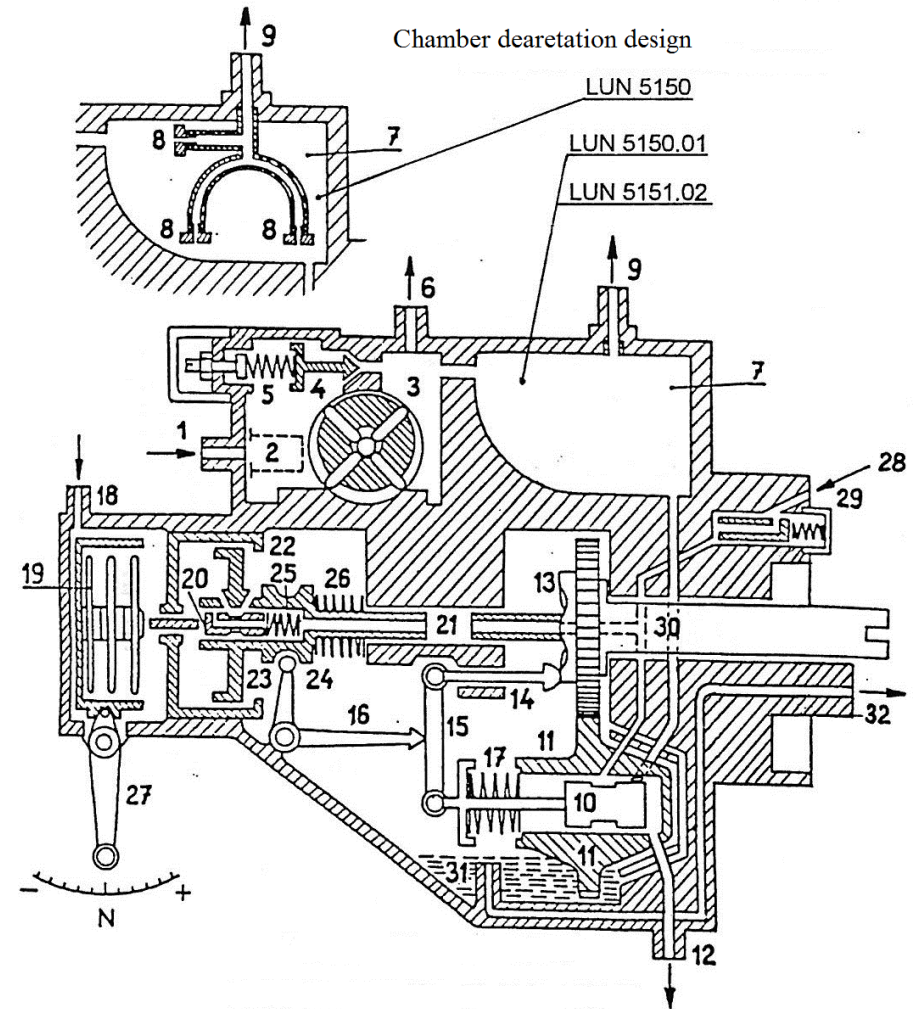

Fuel Injection Pump - scheme
LUN 5150, LUN5150.01, LUN 5151.02

Fig. 2-2b

Injection pump with automatic correction of fuel mixture LUN5150.03 and LUN 5151.03 – function description – see fig. 2-2c.

The fuel injection pump is an automatically operating device, which doses precisely and distributes the individual doses of fuel into separate engine cylinders within the entire range of engine speed (RPM) even with respect to elevation above sea level of airplane (picture 2-2c).

The fuel injection pump sucks in fuel through an inlet union fitting (1) via an inlet fuel cleaner (2) into a bladed fuel delivery pump (3). The fuel delivery pump supplies fuel under a pressure of 0.3 to 0.4 kp/sq.cm into the fuel injection pump deaerating chamber (7). The gases evaporation from fuel are taken together with the returning fuel through a union fitting (9) into the fuel tank. The type has three calibrated holes (8) \varnothing 0.45 in the fuel deaerating chamber (one at the top and two at the bottom) and the fuel return piping provide an escape of fuel gases expelled from the pump by fuel overpressure in any arbitrary position of the engine. The fuel pressure is controlled by a control valve (4), which bypasses the excessive fuel back to the suction space of the fuel delivery pump. The fuel pressure can be controlled by a prestressed spring (5) which presses the valve down into its seat.

The fuel injection pump consists of a pair of plunger pistons (10) which suck fuel through the holes in distributing slide valves (11) and deliver it through the hole in the rotating distributing slide valve (11) into the fuel delivery union fitting (12) of the fuel delivery piping. The pump plunger strokes are variable and are actuated by cams (13) on the face of the fuel pump drive gear wheel. The cam stroke is transferred by a tapet (14) onto a double-arm lever (15) which rests against a control arm (16). The arm changes the lever arm ratio, and thus the plunger stroke as well as the dosing of fuel injected into the engine. The pump plungers are returned back into its initial position by a return spring (17).

The proper mixture ratio depends upon combined action of the injection pump correction and air manifold pressure. The air manifold pressure is caught at the throttle housing and transmitted by means of a rubber hose and through the fuel corrector adjust screw to the fuel injection pump housing (18). The air pressure actuates a set of aneroids, the outer diameter of which is kept in a calibrated bush and when shift a bypass (transfer) plunger piston of the hydraulic servocontrol (20). The plunger piston (20) controls the bypass of pressure oil supplied through a bypass (transfer) pipe (21) from the drive gear into the hydraulic servocontrol, which consists of cylinder (22), piston (23), muft (24) which shifts the control arm

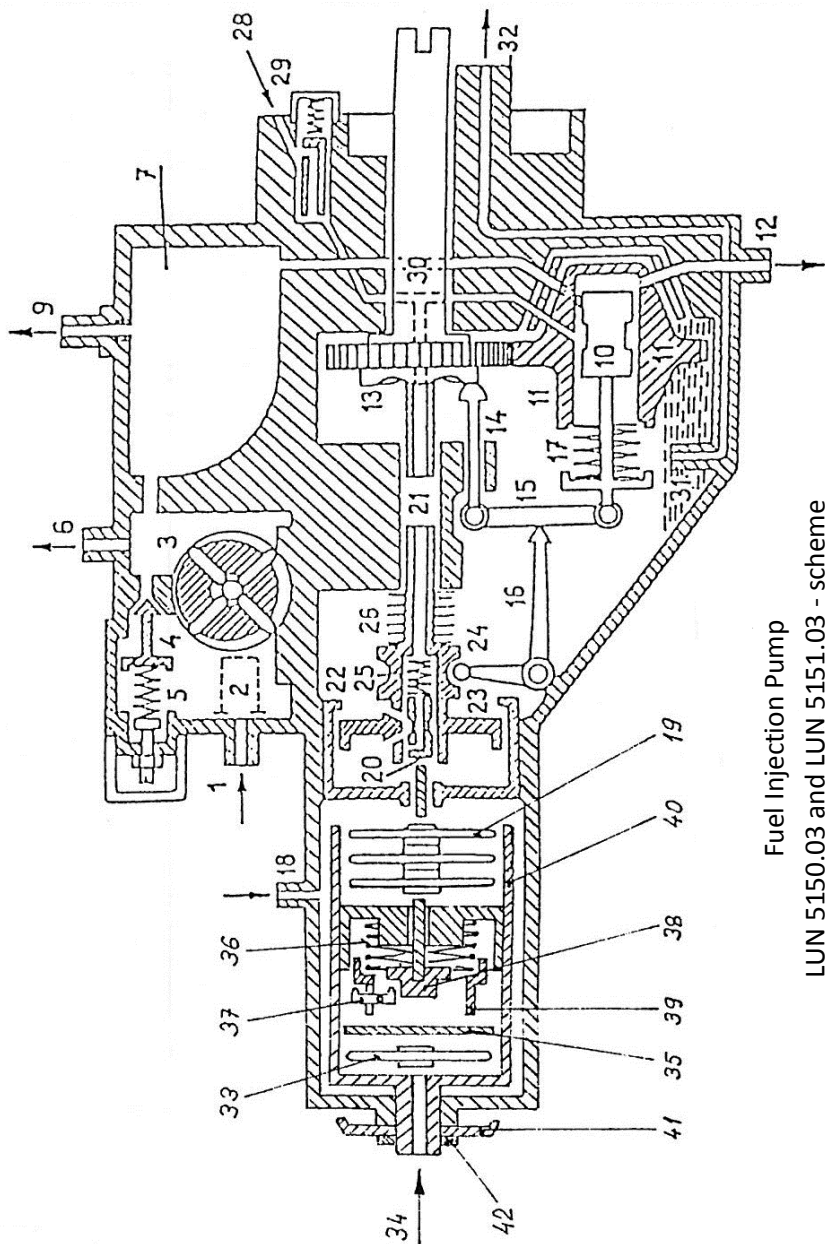

Fuel Injection Pump
LUN 5150.03 and LUN 5151.03 - scheme
Fig. 2-2 c

(16). The piston and the bypass plunger piston are returned by return springs (25) and (26).

If the atmospheric pressure decrease with height, the part of mixture automatic control (operated by independent barometric box (33)) will start working. Atmospheric pressure of surrounding air brought by the pipe-union affects the barometric box. If the outward pressure in barometric box is higher, than pressure of surrounding atmosphere, the box will have tendency expand and it will push on the sliding-circular plate (35). Then sliding-circular plate pushes on spring rest chaplet (39). By pushing on spring rest chaplet the balance beam (37) will start moving. The balance beam will release the balance beam cap (38). After that the set aneroids (19) which release the oil servo-control piston will start moving. The spring will displace the oil servo-control piston. The pressure oil feed of servo-control piston (23) is getting closed. The servo-control piston (23) can displace the sleeve (24) to the position good for the lever ratio (15) change by regulating arm (16). It will make the fuel pump piston (10) stroke higher. When the atmospheric pressure is higher and the height is lower, the system is getting back by spring (36). If the regulation of basic fuel consumption is necessary, the safe nut (42) must be loosen and you can turn it about 2.5 mm. The regulation disc (41) pull out and turn it. If you turning of regulation disc (41), the aneroids case (40) and the servo-control piston is moving too. By turning to the right the fuel consumption gets lower. By turning to the left the fuel consumption grows up. By turning the disk 1/12 revolution (cca 30°), the pump supply changes 0,5 litre for 6-cylinder engines and 0,35 litre for 4-cylinder engines. It is actual for the cruising engine regime. After the regulation the disk must be pushed back, the nut must be retightened. The nut must be safe by the wire and sealed. The regulation of fuel injection pump can be executed only by a mechanic from engine's manufacturer or trained and certified by him.

If the engine oil pressure drops down below 100 kPa, the servo-control will enrich the fuel injection pump mixture automatically so much that the too rich fuel mixture will stop the engine run. The automatic fuel mixture enrichment helps to improve the cold starting of the engine. If the engine is started cold and in a cold weather, the fuel mixture can be enriched more by taking out of saturator needle on correction valve. After starting up the engine, the saturator needle must be put into the off - position.

The pressure oil is supplied from the engine through a hole in the flange (28) into the pressure reducing valve (29), which reduces the pressure of engine oil from

350÷400 kPa down to 200 kPa. The reduced pressure oil lubricates the drive gear bearing (30) and the distributing slide valve (11), through which the oil passes into the groove of the fuel injection pump plunger (10). Thus the oil seals the fuel injection pump plunger against seeping of fuel and lubricates it at the same time. The pressure-reduced oil flows further into the hollow space in the drive wheel and through the bypass pipe (21), to the servo-control mechanism.

The returning oil from bearings and the bypass oil from the servo-control system is evacuated through a pipe (31), the orifice of which determines the oil level inside the fuel injection pump. The oil is evacuated by a gear oil pump (32), which is driven by the fuel injection pump driving shaft. A back pressure valve (33) prevents the pump from oil over flooding if oil level in the engine is too high. A new pump or a pump after an overhaul is to be filled up with oil through side holes of the pump housing until oil starts to flow out through the oil filling holes. All drives inside the pump casing are actuated by the fuel injection pump driving bladed impeller wheel of the fuel delivery pump (3).

Attention: *Any disassembly of fuel injection pump during the operation in the aircraft is prohibited. Also disassembly of corrector valve, even regrooving or covering of air nozzle is prohibited. Air nozzle is situated on the side of top corrector cover. The air nozzle is the part of injected fuel regulation. The corrector valve is situated on the console of control (see page 9-13 to 9-17 pos.(11)).*

Fuel Injection Nozzles

The Yc-070 fuel injection nozzles are of closing type – they get opened only under a sufficient fuel pressure. The pressurized fuel supplied into the injection nozzle passes through a vortex element and hits a needle cone. This cone is lifted up by fuel pressure, the nozzle gets opened, the whirling fuel hits the cone wall and forms a fuel spray cone of 90° apex angle. The fuel cone is aimed towards the centre of the intake air stream in the intake manifold branch. The closing needle seals the injection nozzle hole by the pressure of a return spring attached to the end of the needle. Each fuel injection nozzle is pressure-tested and the due opening pressure is stamped on the jet surface. When fitting new fuel injection nozzles on the engine, use only those ones having exactly an identical opening pressure. If replacing a faulty fuel injection nozzle with a new one, it is allowed to use only a new injection nozzle of the same opening pressure as those ones fitted in the engine.

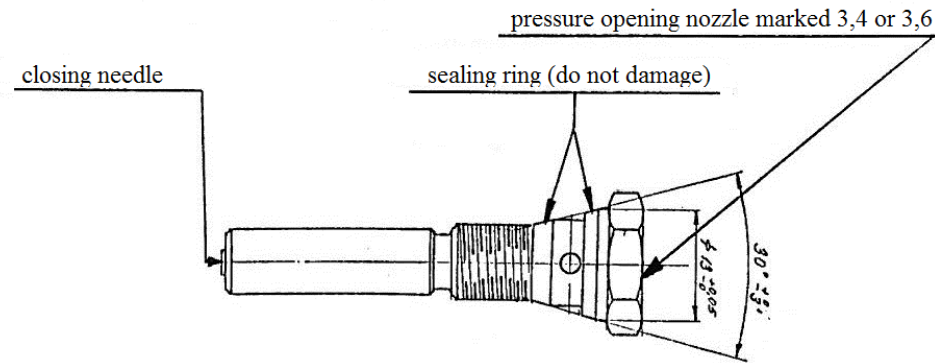

Injection Nozzle Yc-070

Fig. 2-2d

5. IGNITION SYSTEM

The engine ignition system consists of two shielded, independent ignition installations. Two shielded magnetos are mounted on engine. They are provided with automatic mechanism for ignition advance change with respect to the engine RPM. The magnetos are vertically mounted at the rear end of the crankcase on both sides of the oil sump, against which they are fastened by means of fixing belts. Before mounting on engine, a bevelled gear is assembled at the magneto rotor shaft end and the adapter is fastened on the magneto stator by means of threaded pins. The adapter is then fastened on the crankcase flange by means of two studs and nuts. The magnetos are driven by bevelled gears, the left magneto from the left drive outlet and the right magneto from the right drive outlet. The ignition harness is provided with shielding braid and is protected in shielding tubes on its conduit to spark plugs: from the left magneto to spark plugs on the exhaust side and from the right magneto to the intake side spark plugs. The wires are connected to both spark plug and magneto by means of terminals with socket nuts. For proper connection, the wires are provided with plates at each end, bearing a number corresponding to the pertinent cylinder and connection on the magneto distributor block. Both magnetos have short-circuit wires provided with socket nuts for coupling in case of ignition grounding. To facilitate engine start, the spark intensity is increased, when pressing the starter button, by the action of the starting vibrator.

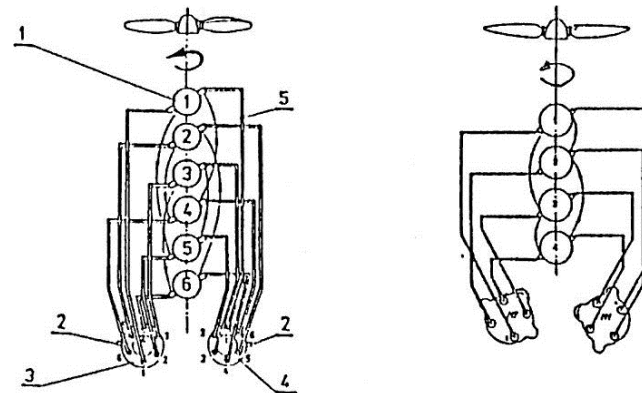

- 1- Cylinder
- 2- Short-Circuit Terminal
- 3- Right Magneto
- 4- Left Magneto
- 5- Ignition Harness

Fig. 2-3 a

Ignition Harness Diagram

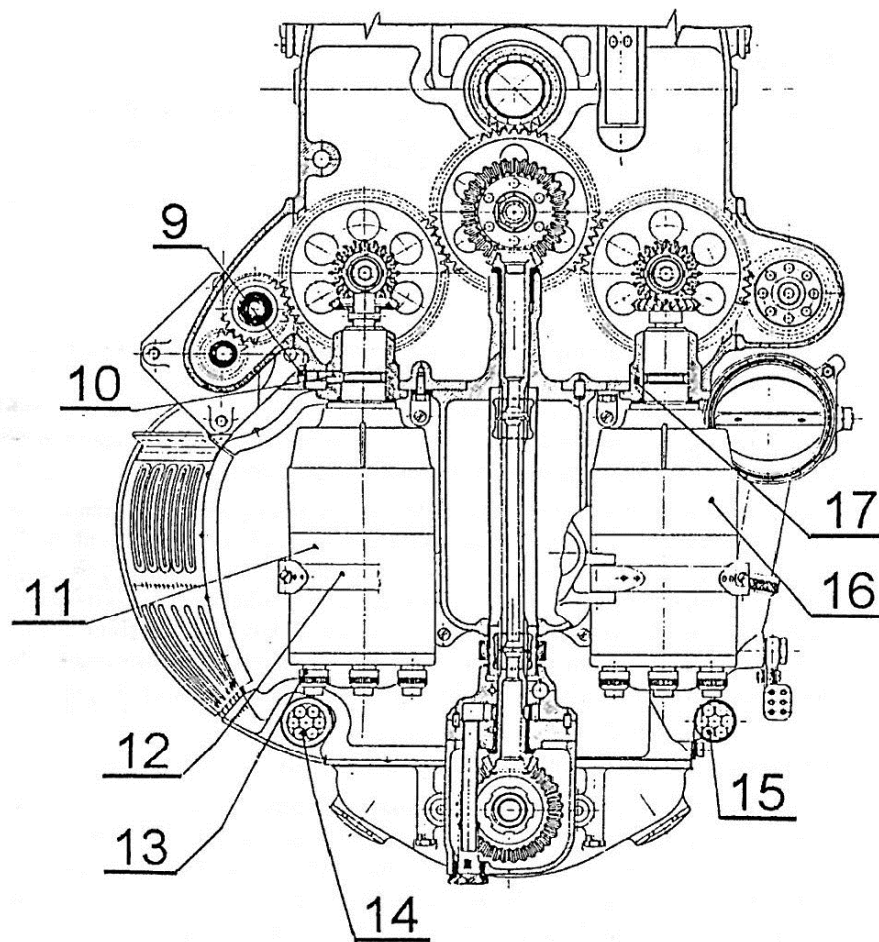

- | | |
|----------------------------|---------------------------------|
| 9- Magneto Thread Pin Plug | 14- Ignition Harness Left Tube |
| 10- Magneto thread Pin | 15- Ignition Harness Right Tube |
| 11- Left Magneto | 16- Magneto |
| 12- Magneto Fixing Belts | 17- Magneto Drive Adapter |
| 13- Ignition Wire Outlets | |

Fig. 2-3 b
Ignition Harness Diagram

6. OIL SYSTEM

The engine lubrication is pressure, closed circuit, dry sump type having oil tank connected to the oil circuit by means of rubber hoses. The oil circulation is achieved by the action of gear type oil pumps: the main pressure oil pump and the scavenge pump. The main pump is composed of the pressure section and the scavenge section. It is mounted on the rear wall of the crankcase and it is driven by the drive gear on the left outlet. The auxiliary scavenge pump is mounted on the drive gear housing and it is driven by the vertical drive shaft.

A. Pressure oil circuit

The pressure oil circulation is ensured by the pressure section of the main oil pump. It surges oil from the tank over the triple oil inlet strainer (placed in the pump case) and then evacuates the oil through a pipe to the three ways fitting mounted on the high pressure valve. This valve is screwed to the crankcase longitudinal oil conduit. The oil is distributed from the three ways fitting to different engine parts as follows:

- a/ The oil flows through the high pressure valve along the crankcase main longitudinal conduit and the transversal conduits to the crankshaft main bearings and through the canals in the crankshaft to the connecting rod bearings. The oil splashed from the bearings lubricates the cylinders, pistons and piston pins. The oil splashed from the first main bearing lubricates the crankshaft ball bearing. The oil from the rear main bearing is lead through the crankcase vertical and transversal conduit to the bearings of the accessory drive gears. At the crankcase longitudinal oil conduit end there is a fitting for oil pressure gauge line.
- b/ The oil flows toward supercharger and lubricates the bearings and the gears.
- c/ The oil is flowing through a pipe to the fitting, from where it continues either to the crankcase and lubricates the bearing of the vertical shaft upper part or through a hose to the drive gear housing and lubricates the vertical shaft bearing. The oil is distributed in the drive gear housing to the injection pump and to the camshaft. Inside the injection pump it lubricates bearings and actuates the pump servomechanism. Inside the hollow camshaft it is installed an insert. The oil flows between this insert and the camshaft and lubricates, through the orifices in camshaft, the bearings and the cams. The oil splashed inside the camshaft housings lubricates the rockers, the valve stems and the

contact surface between valve stem tip and rocker adjust screw.
 The pressure oil to the propeller governor is lead from the oil pump fitting through a flexible hose.

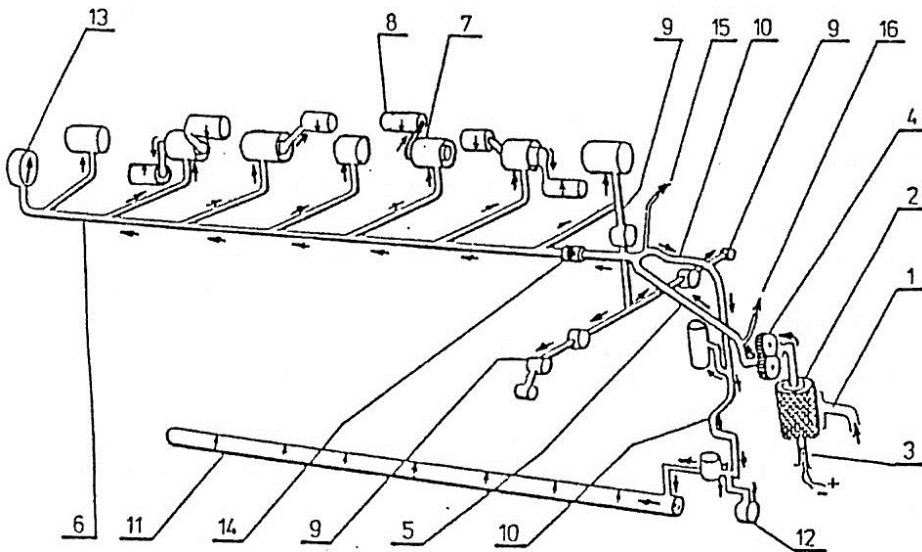

- | | |
|--|---|
| 1- Oil Inlet From Tank | 10- Pressure Oil Line To Drive Gear Housing |
| 2- Triple Inlet Oil Strainer | 11- Camshaft Pressure Oil To Lubricate Cams |
| 3- Temperature Indicator Capability | 12- Injection Pump Pressure Oil Lubrication |
| 4- Pressure Pump | 13- Oil Pressure Gauge Fitting |
| 5- Pressure Oil Line | 14- High pressure Oil Valve |
| 6- Main Longitudinal Crankcase Oil Conduit | 15- Pressure Oil To Supercharger |
| 7- Crankshaft Main Bearings Lubrication | 16- Pressure Oil To Propeller Governor |
| 8- Crankpin Bearings Lubrication | |
| 9- Vertical And Transversal Oil Conduit For Accessory Drive Gear Lubrication | |

Fig. 2-4

Pressure oil circuit

B. Oil scavenging

Normal Operation

Scavenging oil from engine is ensured by the scavenge section of the main oil pump concomitantly with the auxiliary oil scavenge pump.

The oil splashed inside the crankcase is collected at its lower side and flows through the orifices in the transversal walls to the rear end. The oil from the supercharger is also collected at the rear end of the crankcase. The oil collected at the crankcase rear end then flows into the oil sump mounted at the crankcase bottom side. The returning oil from the propeller governor is also collected through a flexible pipe in the oil sump. The oil from the oil sump is then surged by the scavenge section of the main oil pump over an oil screen and through the oil inlet line and pumped back to the oil tank through a flexible pipe.

The oil splashed inside the camshaft housings flows to the drive gear housing through the longitudinal orifices in the camshaft bearings. The oil from the frontal end of the crankcase flows, especially when engine has this end tilted downwards, through the frontal scavenge tube to the camshaft housing frontal lid and from here through the insert in the camshaft to the accessory drive housing. The returning oil from the injection pump flows also to the accessory drive housing. From here, the oil is surged by the auxiliary scavenge pump and pumped through a flexible hose to the fitting on the main oil pump and from here, together with the oil scavenged from the oil sump, back into the oil tank.

Aerobatic Operation by M 137A/AZ, M 332AK, M 337AK, M 132AK

Oil system by aerobatic engines - model M137A/AZ, M332AK, M337AK and M132AK, is made in the different way, than by other engine models. By inverted flight is the oil scavenged from the engine. Because of this reason is on the pump suction part connected gravity valve, which automatically /by inverted flight/ changes over oil suction from oil collector for suction from crank case, where oil by aerobatic flying is assembled. There is the gravity valve also in the distribution driving case, which executes /by inverted flight/ oil suction from bottom or upper case space, according to engine position. By aerobatics the oil system is functioning.

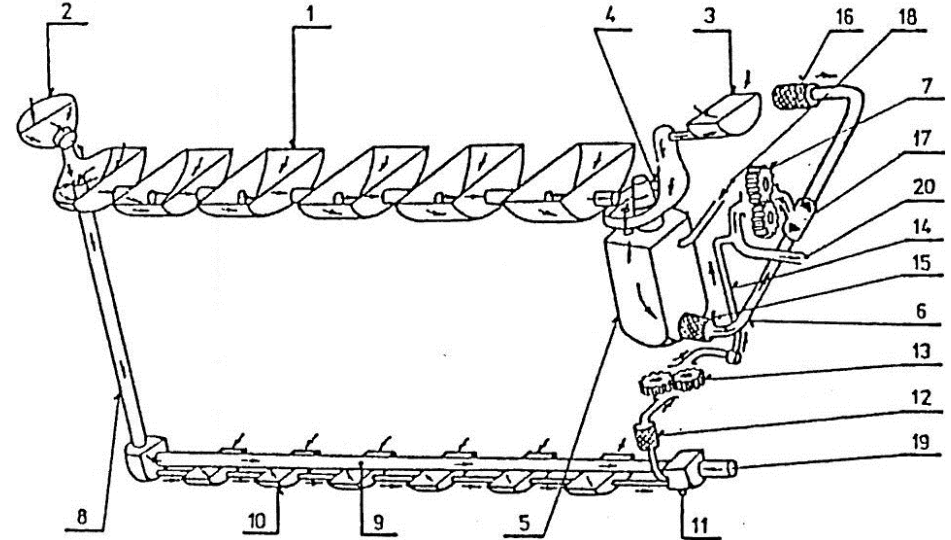
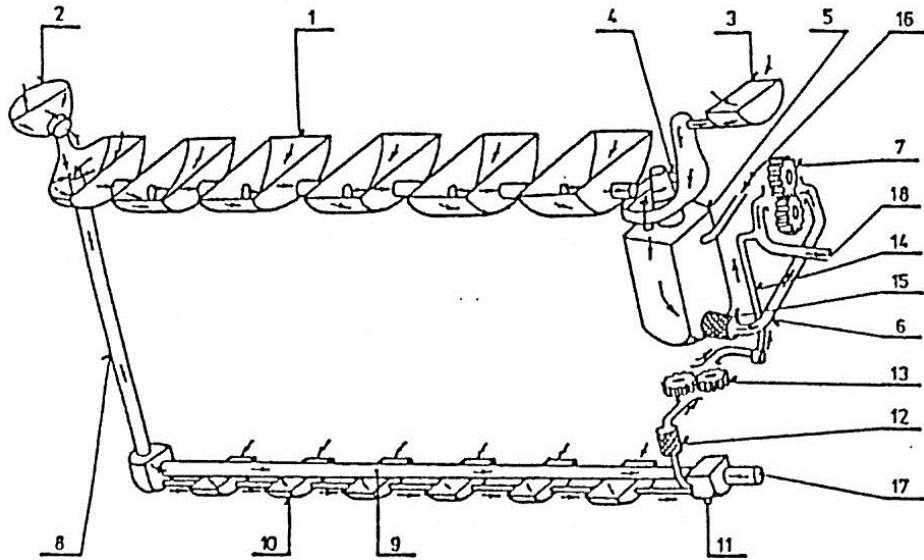

- | | |
|--|--|
| 1- Crankcase Bottom | 11- Oil Drain Plug |
| 2- Frontal Lid Lower Part | 12- Scavenged Oil Strainer in Drive Gear Housing |
| 3- Supercharger Housing Lower Part | 13- Auxiliary Scavenge Pump |
| 4- Crankcase Rear End Bottom | 14- Auxiliary Scavenge Pump Oil outlet Hose |
| 5- Oil Sump | 15- Oil Sump Scavenged Oil Strainer |
| 6- Piping To Scavenge Oil Pump | 16- Propeller Governor Returning Oil |
| 7- Main Scavenging Pump | 17- Injection Pump Scavenged oil |
| 8- Crankcase Frontal End Oil Scavenge Tube | 18- Engine Scavenged Oil to Tank |
| 9- Camshaft Insert | |
| 10- Camcase Bottom | |

- | | |
|--|---|
| 1- Crankcase Bottom | 12- Scavenged Oil Strainer with Gravity Valve in Drive Gear Housing |
| 2- Frontal Lid Lower Part | 13- Auxiliary Scavenge Pump |
| 3- Supercharger Housing Lower Part | 14- Auxiliary Scavenge Pump Oil Outlet Hose |
| 4- Crankcase Rear End Bottom | 15- Oil Sump Scavenged Oil Strainer |
| 5- Oil Sump | 16- Scavenged Oil Strainer in Top Lid Fitting |
| 6- Piping To Scavenge Oil Pump | 17- Scavenge Oil Gravity Valve For Inverted Flight |
| 7- Main Scavenging Pump | 18- Propeller Governor Returning Oil |
| 8- Crankcase Frontal End Oil Scavenge Tube | 19- Injection Pump Scavenged Oil |
| 9- Camshaft Insert | 20- Engine Scavenged Oil to Tank |
| 10- Camcase Bottom | |
| 11- Oil Drain Plug | |

Fig. 2-5

Fig. 2-6

Typical M337A, M332A, M132A Scavenged Oil Circuit

Typical M337AK, M332AK, M132AK, M137A/AZ Scavenged Oil Circuit

7. CRANKCASE VENTING

For crankcase venting, there is used a breather in the crankcase lid, finished with a fitting to which a hose is connected, whose second end is placed outside engine cowling in an underpressure region. The breather fitting is provided with an adapter retaining splashed oil and oil vapors. See Fig. 2-1.

8. COOLING SYSTEM

The engine is cooled by the air stream, which is aspirated through the scoop entrance in the engine front cowl by the air scoop fixed on engine. The cooling air is farther conducted along the cylinders and directed by baffles to stream between cylinder barrel and head fins. From the air scoop, cooling air is prelevated to cool the generator and the injection pump.

9. ENGINE STARTING

A. Engine equipped with supercharger

There is an electric starter mounted on the supercharger. It must be switched on during the process of starting the engine. It consists of an electric motor and gear casing with worm gear drive and a pull-out claw controlled by an electromagnet. Both the starter and the electromagnet are switched on by pressing the starting push button, the claw is pulled in mesh with the shaft of the supercharger turning over the crankshaft through its epicyclic gear. When the engine is put into operation the claw is pulled out of mesh by means of a spring. See Fig. 2-7 and Fig. 7-6a.

B. Engine without supercharger

The starter is mounted on the rear flange of the crankcase and it consists of an electromotor, gear casing with triple epicyclic gear and a pull-out claw. The claw is pulled out in mesh with the claw of the crankshaft on the basis of a difference in revolutions between the second and third epicyclic gear.

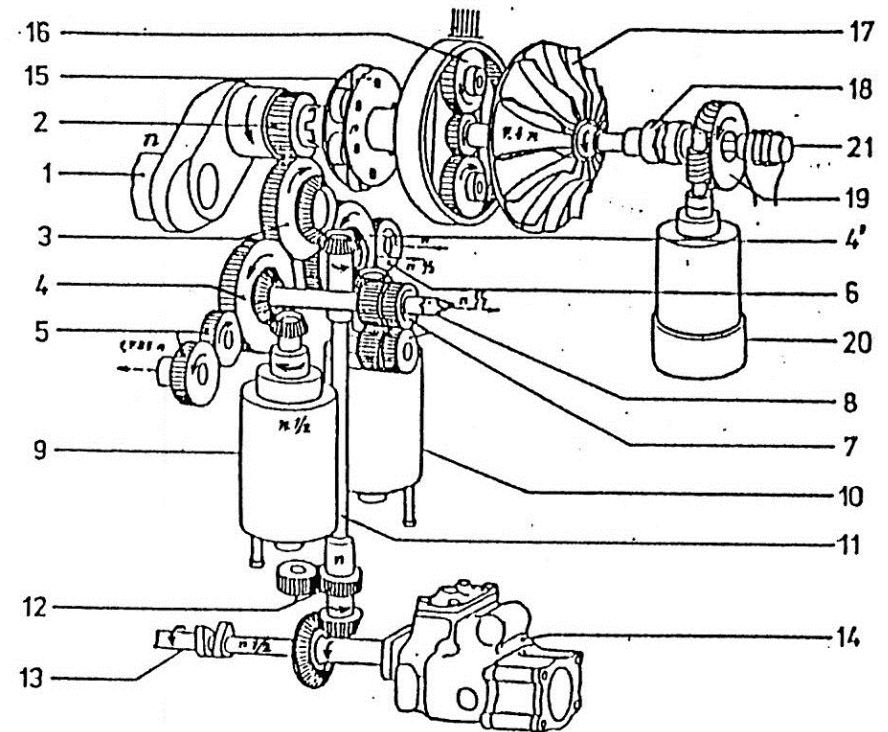

- | | |
|--|---------------------------------------|
| 1- Crankshaft | 11- Vertical Drive Shaft |
| 2- Crankshaft Gear | 12- Auxiliary Oil Scavenging Oil Pump |
| 3- Intermediate Drive Gear | 13- Camshaft |
| 4- Left Outlet for Left Magneto and Drive. 4'-Right Outlet for Right Magneto, RPM Indicator and Propeller Governor Drive | 14- Injection Pump |
| 5- Generator Drive Gear | 15- Elastic Coupling |
| 6- Electrical RPM indicator Drive Gear | 16- Epicyclic Gear |
| 7- Main Oil Pump | 17- Supercharger Impeller |
| 8- Mechanical RPM Indicator Drive Spline | 18- Starter frontal Dented Gear |
| 9- Left Magneto | 19- Starter Worm Gear |
| 10- Right Magneto | 20- Starter Electromotor |
| | 21- Starter Engaging Electromagnet |

Fig. 2-7
Typical Gear Train diagram (M337, M332 families)

10. ACCESSORY DRIVE

A. Mechanical RPM indicator drive

The main oil pump shaft is provided with a drive spline for the RPM indicator and an adapter fastened on the pump case. The RPM indicator flexible shaft is connected to the adapter by means of the socket nut and coupled by means of grooves to the drive outlet.

B. Electrical RPM indicator drive

On the right side of the crankcase, there is mounted the RPM indicator drive housing provided with flange for electrical RPM indicator installation.

C. Propeller governor drive

At the rear end of the crankcase, there is provided the flange for propeller governor installation. To the right rotating drive spline, driven from the right drive outlet, there is coupled the governor driving shaft.

D. Generator drive

The generator drive gear train is supported in the housing mounted on the left flange of the crankcase. The motion is transmitted from the left drive outlet gear, over the intermediate gear, to the generator pinion. The drive spline has interior grooves matching the generator shaft. Both drive gears are supported in bronze bushings. The oil sealing ring installed on generator drive hinders oil to penetrate inside generator. The generator is flanged, with grooved shaft end. The generator is mounted on the frontal generator drive housing flange and it is additionally fastened in the crankcase recess means of a fixing belt.

11. ENGINE INSTALLATION

On each side of the crankcase there are two pads cast together with the crankcase intended for mounting the pins of the engine mounts.

12. ACCESSORIES

Injection pumps

LUN 5151.02 -for four cylinder
 LUN 5150 -for six-cylinder
 LUN 5150.01 -for six cylinder
 (from 1.1.1977)

Injection pump is destined for fully aerobic engines. It is equipped with manual fuel correction of fuel mixture.

Injection pumps

LUN 5151.03-for four cylinder
 LUN 5150.03-for six-cylinder

Injection pump is destined for fully aerobic engines. It is equipped with automatic fuel correction of fuel mixture.

Injection nozzle

Yc-070

Serves to pulverize the fuel in the engine air intake piping.

Magnetos

LUN 2225 - for four cylinder
 LUN 2221.13- for six-cylinder

It is equipped with centrifugal ignition advance regulator.

Starter vibrator

LUN 2231

Is an electromagnetic equipment connected to the battery, which boosts the engine ignition system during engine starting. It is fastened on the aircraft firewall.

Starter motor

LUN 2253 (left-turning)

Is an electromotor, which cranks the engine during starting. It equips engines with supercharger

Starter motor

LUN 2254 (right-turning)

Is destined for engines without supercharger, which are equipped with the P 2131 starter.

Generator

LUN 2111 (600W)
 LUN 2111.1 (750W)

Supplies the aircraft electric system with current. It operates in a common circuit with the regulating relay.

Regulating relay

LUN 2141 (600W)
 LUN 2141.1 (750W)

Is the equipment, which maintains a constant voltage at different generator RPM and connects or disconnects the generator from the battery in the proper moment. It is mounted on the aircraft firewall.

SECTION 3

SPECIFICATIONS

1/ Technical specifications3-2

2/ Operating limitations3-16

3/ Engine power characteristic3-17

4/ Theoretic valve timing3-22

1. TECHNICAL SPECIFICATIONS

Engine Models:

- M 132A -four-cylinder normally aspirated version
- M 132AK -aerobatic oil system permitted inverted flights
- M 332A -four-cylinder supercharged version normally aspirated
- M 332AK -aerobatic oil system permitted inverted flights
- M 137A -six-cylinder full aerobatics engine
- M 137AZ -full aerobatics engine with rear opposed air inlet
- M 337A -six-cylinder supercharged version normally aspirated
- M 337AK -aerobatic oil system permitted inverted flights

Crankshaft rotation viewing from engine rear end, left (c'lockwise)

Propeller drive ratio: 1:1

	M332, M132	M137, M337
Basic data:		
Cylinder number:	4	6
Bore:	105mm (4.14 in.)	
Stroke:	115mm (4.53 in)	
Displacement:	3,98dm ³ (243 cu.in.)	5,97dm ³ (364 cu.in.)
Compression ratio:	6,3:1	

Valve Operating System

Valves per cylinder head:	1 intake, 1 exhaust
Intake valve seat angle:	120°
Exhaust valve seat angle:	90°
Intake valve cold clearance:	0,25mm (0.0098 in.)
Exhaust valve cold clearance:	0,40mm (0.0157 in.)

	M332, M132	M137, M337
Ignition:		
Magneto (two on engine):	LUN 2225	LUN 2221.13
Magneto drive ratio:		2:1
Firing order:	1-3-4-2	1-5-3-6-2-4
Spark occurs:		7° BTC
Breaker gap:	0,25 ÷ 0,35 mm (0.0098 ÷ 0.0138 in.)	
Shielded spark plugs (two on each cylinder head):	PAL L 22,62	
Spark plug thread:	M12 x 1,25	
Electrode gap:	0,45 ÷ 0,5 mm (0.0157 ÷ 0.0197 in.)	
Fuel system:		
Injection pump:	LUN 5151.02 LUN 5151.03	LUN 5150.01 LUN 5150.03
Injection pump drive ratio:	2:1	
Correction adjust valve:	705-1000 or 705-1000A	
Injection nozzles type:	Yc-070	
Injection nozzles number:	4+1	6+1
Nozzle marking (according to opening pressure):	3,4 or 3,6 on the nozzle skirt; nozzles having the same marking must be installed on engine	
Fuel filtering efficiency (max. foreign particle size):	0,03mm (0.0012 in.)	
Basic mixture setting (mixture Control lever setting against Injection pump mixture dial):	valid for LUN 5151.02 and LUN 5150.01 -2 increments from „N“	
Injection pump oil inlet pressure:	min. 100 kPa (14.5 PSI)	
Fuel Pressure:		
Operation limits:	10 ÷ 50 kPa (1.45 ÷ 7.25 PSI)	

	M332, M132	M137, M337
Operation Pressure:	30 ÷ 40 kPa (4.35 ÷ 5.8 PSI)	
Oil system:		
Main Oil Pump:	gear type double-pressure and scavenge	
Drive Ratio:	2:1	
Auxiliary Oil Pump:	gear type - scavenge	
Drive Ratio:	1:1	
Oil Pressure:		
Limit Values:	220 ÷ 450 kPa (31.9 ÷ 65.25 PSI)	120 ÷ 450 kPa (17.4 ÷ 65.25 PSI)
Operation Range:	350 ÷ 400 kPa (50.75 ÷ 58.0 PSI)	350 ÷ 400 kPa (50.75 ÷ 58.0 PSI)
Idle Min. Pressure at 60°C (140°F)	220 kPa (31.9 PSI)	180 kPa (26.1 PSI)
Oil Temperature:		
Idle Min. Pressure at 80°C (176°F)	-----	120 kPa (17.4 PSI)
Oil Temperature (M337 and M137)		
Oil Inlet Temperature:		
Engine Test Min. Temperature:	25°C (77°F)	
Limit Values:	40° ÷ 85°C (104° ÷ 185°F)	
Operation Range:	40° ÷ 80°C (104° ÷ 176°F)	
Short Time Max. Temperature:	85°C (185°F) for 10 min.	
Idle Min. Oil Quantity:	5 lit (1.32 US gal.)	7 lit. (1.85 US gal.)
Cylinder Head Temperature		
(measured under spark plug):	4 th	3 rd
Limit Values:	70° ÷ 210°C (158° ÷ 410°F)	
Operation Range:	140° ÷ 185°C (284° ÷ 365°F)	
Take – Off Max. temperature:	210°C (410°F) for 5 min.	



SPECIFICATIONS

	M332, M132	M137, M337
Descent Min. Temperature:	70°C (158°F)	
Cooling:		
Cooling procedure:	cooling air stream	
Min. cooling air pressure drop between cylinder front and rear during Take-off:	160 mm water column (0.4633 inHg)	200 mm water column (0.5792 inHg)
Supercharging: (M332, M337)		
Compressor:	centrifugal, disengageable	
Impeller Driving Ratio:		
-engaged:	1:7.4	
-disengaged:	1:1	
Starting:		
Starter:	electrical, with worm gear drive and engaging frontal dented gear	
Starter Electromotor:	LUN 2253, c'c'wise (M 332, M337) LUN 2254, c'wise (M 132, M137)	
Voltage:	28 V	
Speed:	6000 RPM	
Power:	1.1 kW	
Starter to Crankshaft Drive Ratio:	111:1 (M 332, M 337) 129:1 (M 137, M 132)	
Generator:	LUN 2111 or LUN 2111.1	
Voltage:	28V	
Speed:	4000 ÷ 6000 RPM	
Power:	600 W or 750 W	

OPERATOR'S MANUAL

	M332, M132	M137, M337		
Drive Ratio:	1 : 1.785			
Regulator Relay:	LUN 2141 or LUN 2141.1			
Voltage:	28V			
Nominal Power:	600 W or 750 W			
Max. power for 5 min.:	900 W			
Starting Vibrator:	LUN 2231 or 2231.1			
Operation Voltage:	24 ÷ 28 V			
Operation Current:	1 + 0.2 A (max. 1 min. time overload)			
Engine Weights:	M 132	M 332	M 137	M 337
Standard Equipment, Dry Weight:	105 kg (230 lbs.)	113 kg (249 lbs.)	147 kg (324 lbs.)	153 kg (337 lbs.)
Total with accessories and rest of oil in engine:	113 kg (249 lbs.)	122 kg (269 lbs.)	156 kg (344 lbs.)	162 kg (357 lbs.)
Weight tolerance: 4-cyl. engines = ±2%, 6-cyl. engines = ±2.5%				

At each engine on the crankcase lid, there is a nameplate containing engine model designation, series number and basic technical data.

TECHNICAL PARAMETRES M 332A, M332AK

Power, RPM, Boost Pressure

ENGINE REGIME		MAX. TAKE OFF (MAX. 5 MIN.)	MAX. CONTINUOUS	MAX. CRUISING H=0M ISA	IDLING
Power	kW	103±2,5%	84,6±2,5%	71,3±2,5%	-
	HP	140±2,5%	115±2,5%	97±2,5%	-
RPM		2700±50%	2550±3%	2400±3%	500-600
Boost pressure	kPa	118±2	98±2	90±2	-
	ata	1,2±0,02	1±0,02	0,92±0,02	-
	inHg	34,8±0,6	28,9±0,6	26,6±0,6	-
	PSI	17,1±0,3	14,2±0,3	13,1±0,3	-
Supercharger		engaged	disengaged	disengaged	disengaged

Above mentioned outputs are engine powers on ground testing banch by standard atmosphere ISA and by assumption of suction air ram pressure 2 kPa (0.059 inHg).

Engines are not equipped by exhaust silencer.

See the note at 3-16 page.

Page without text

Fuel and Oil consumption

ENGINE REGIME BY ISA		Max. CONTINUOUS	Max. CRUISING
Fuel consumption	lit./h	34,5	28,6
	gal./h	9,1	7,6
Oil consumption	lit./h	0,4	-
	gal./h	0,1	-

Fuel and oil pressure

M 332A, M332AK

ENGINE REGIME		OVERLIMITED RPM	MAX. TAKE OFF	MAX. CONTINUOUS	MAX. CRUISING	IDLING
RPM		2 860	2 700	2 550	2 400	500÷600
Fuel pressure	kPa	max. 50	max. 40	30÷40	min. 30	min. 10
	PSI	max. 7,25	max. 5,8	4,35÷5,8	min. 4,35	min. 1,45
Oil pressure	kPa	max. 450	max. 400	350÷400	min. 350	min. 220
	PSI	max. 65,25	max. 58	50,75÷58	min. 50,75	min. 31,9

Inlet oil temperature

ENGINE REGIME		OPERATING RPM 500-2550	TAKE OFF RPM 2700	OVERLIMITED RPM 2860	ENGINE TEST
Oil temp.	°C	normal. 40÷80 max. 85 for 10 min.	max. 85 for 10 min.	max. 85	min. 25
	°F	normal 104÷176 max. 185 for 10 min	max. 185 for 10 min.	max. 185	min. 77

Cylinder head temperature

---		Normal oper. range	Take off & climbing	Overlimited RPM	By descent
Cyl. head temp.	°C	140÷185	max. 210 for 5 min.	max. 210	min. 70
	°F	284÷365	max. 410 for 5 min.	max. 410	min. 158

For preventing of overlimited max. oil or cylinder-head temperature before prescribed time limit the engine regime must be changed and the engine cooled for prescribed value

TECHNICAL PARAMETRES M 137A, M 137AZ

Power, RPM, Boost pressure

ENGINE REGIME		MAX. TAKE OFF (MAX. 5 MIN.)	MAX. CONTINUOUS	MAX. CRUISING H=0M ISA	IDLING
Power	kW	132±2,5%	117,6±2,5%	103±2,5%	-
	HP	180±2,5%	160±2,5%	140±2,5%	-
RPM		2750±3%	2680±3%	2580±3%	500÷600
Boost pressure	kPa	100±2	95±2	87±2	-
	ata	1,02±0,02	0,97±0,02	0,89±0,02	-
	inHg	29,5±0,6	28±0,6	25,8±0,6	-
	PSI	14,5±0,3	13,9±0,3	12,6±0,3	-

Above mentioned outputs are engine powers on ground testing banch by standard atmosphere ISA and by assumption of suction air ram pressure 2kPa (0.059 inHg).

Engines are not equipped by exhaust silencer.

See the note at 3-16 page.

Fuel and oil consumption

ENGINE REGIME BY ISA		MAX. CONTINUOUS	MAX. CRUISING
Fuel consumption	lit./h	51,9	43,1
	gal./h	13,7	11,4
Oil consumption	lit./h	1,2	-
	gal./h	0,3	-

Fuel and oil pressure
M 137A, M 137AZ

ENGINE REGIME		OVERLIMITED RPM	MAX. TAKE OFF	MAX. CONTINUOUS	MAX. CRUISING	IDLING
RPM		2 860	2 750	2 680	2 580	500-600
Fuel pressure	kPa	max. 50	max. 40	30÷40	min. 30	min. 10
	PSI	max. 7,25	max. 5,8	4,35÷5,8	min. 4,35	min. 1,45
Oil pressure	kPa	max. 450	max. 400	350÷400	min. 350	min. 120
	PSI	max. 65,25	max. 58	50,75÷58	min. 50,75	min. 17,4

Inlet oil temperature

ENGINE REGIME		OPERATING RPM 500-2680	TAKE OFF RPM 2750	OVERLIMITED RPM 2860	ENGINE TEST
Oil temp.	°C	normal. 40÷80 max. 85 for 10 min.	max. 85 na 10 min.	max. 85	min. 25
	°F	normal 104÷176 max. 185 for 10 min	max. 185 na 10 min.	max. 185	min. 77

Cylinder head temperature

--		Normal oper. range	Take off & climbing	Overlimited RPM	By descent
Cyl. Head temp.	°C	140÷185	max. 210 for 5 min.	max. 210	min. 70
	°F	284÷365	max. 410 for 5 min.	max. 410	min. 158

For prevention of overlimited max. oil or cylinder-head temperature before prescribed time limit the engine regime must be changed and the engine cooled for prescribed value.

TECHNICAL PARAMETRES M 337A, M337AK
Power, RPM, Boost pressure

ENGINE REGIME		MAX. TAKE OFF (MAX. 5 MIN.)	MAX. CONTINUOUS	MAX. CRUISING H=0M ISA	IDLING
Power	kW	154,4±2,5%	125±2,5%	103±2,5%	-
	HP	210±2,5%	170±2,5%	140±2,5%	-
RPM		2750±30 *	2600±3%	2400±3%	500÷600
Boost pressure	kPa	118 [±]	98±2	90±2	-
	ata	1,2 ±0,02	1±0,02	0,92±0,02	-
	inHg	34,8 ±0,6	28,9±0,6	26,7±0,6	-
	PSI	17,1 ±0,3	14,2±0,3	13,1±0,3	-
Supercharger		engaged	disengaged	disengaged	disengaged

Above mentioned outputs are engine powers on ground testing banch by standard atmosphere ISA and by assumption of suction air ram pressure 2kPa (0.059 inHg).

Engines are not equipped by exhaust silencer.

See the note at 3-16 page.

*-Tolerance for engine speed is ± 50 RPM when fixed pitch propeller is used

Fuel and oil consumption

ENGINE REGIME BY ISA		MAX. CONTINUOUS	MAX. CRUISING
Fuel consumption	lit./h	51,7÷56,4	40÷42
	gal./h	13,7÷14,9	10,6÷11,1
Oil consumption	lit./h	0,2÷1,8	0,19÷1,16
	gal./h	0,05÷0,47	0,05÷0,3

Fuel and Oil Pressure
M 337A, M 337AK

ENGINE REGIME		OVERLIMITED RPM	MAX. TAKE OFF	MAX. CONTINUOUS	MAX. CRUISING	IDLING
RPM		2 860	2 750	2 600	2 400	500÷600
Fuel pressure	kPa	max. 50	max. 40	30÷40	min. 30	min. 10
	PSI	max. 7,25	max. 5,8	4,35÷5,8	min. 4,35	min. 1,45
Oil pressure	kPa	max. 450	max. 400	350÷400	min. 350	min. 120
	PSI	max. 65,25	max. 58	50,75÷58	min. 50,75	min. 17,4

Inlet oil temperature

ENGINE REGIME		OPERATING RPM 500-2680	TAKE OFF RPM 2750	OVERLIMITED RPM 2860-3025	ENGINE TEST
Oil temp.	°C	normal. 40÷80 max. 85 for 10 min.	max. 85 for 10 min.	max. 85	min. 25
	°F	normal 104÷176 max. 185 for 10 min.	max. 185 for 10 min.	max. 185	min. 77

Cylinder head temperature

--		Normal oper. range	Take off & climbing	Overlimited RPM	By descent
Cyl. Head temp.	°C	140÷185	max. 210 for 5 min.	max. 210	min. 70
	°F	284÷365	max. 410 for 5 min.	max. 410	min. 158

For prevention of overlimited max. oil or cylinder-head temperature before prescribed time limit the engine regime must be changed and the engine cooled for prescribed value.

TECHNICAL PARAMETRES M 132A, M132AK
Power, RPM, Boost pressure

ENGINE REGIME		MAX. TAKE OFF (MAX. 5 MIN.)	MAX. CONTINUOUS	MAX. CRUISING H=0M ISA	IDLING
Power	kW	90±5%	80±2,5%	70±2,5%	-
	HP	122,4±2,5%	108,8±2,5%	95,2±2,5%	-
RPM		2700±3%	2600±3%	2500±3%	500÷600
Boost pressure	kPa	98±2	93,2±2	86,3±2	-
	ata	1±0,02	0,95±0,02	0,88±0,02	-
	inHg	28,9±0,6	27,5±0,6	25,5±0,6	-
	PSI	14,2±0,3	13,5±0,3	12,5±0,3	-

Above mentioned outputs are engine powers on ground testing banch by standard atmosphere ISA and by assumption of suction air ram pressure 2kPa (0.059 inHg)

Engines are not equipped by exhaust silencer.

See the note at 3-16 page.

Fuel and oil consumption

ENGINE REGIME BY ISA		MAX. CONTINUOUS	MAX. CRUISING
Fuel consumption	lit./h	32	28,6
	gal./h	8,4	7,6
Oil consumption	lit./h	0,4	-
	gal./h	0,1	-

Fuel and oil pressure.

M 132A, M132AK

ENGINE REGIME		OVERLIMITED RPM	MAX. TAKE OFF	MAX. CONTINUOUS	MAX. CRUISING	IDLING
RPM		2 860	2 700	2 600	2 500	500÷600
Fuel pressure	kPa	max. 50	max. 40	30÷40	min. 30	min. 10
	PSI	max. 7,25	max. 5,8	4,35÷5,8	min. 4,35	min. 1,45
Oil pressure	kPa	max. 450	max. 400	350÷400	min. 350	min. 220
	PSI	max. 65,25	max. 58	50,75-58	min. 50,75	min. 31,9

Inlet oil temperature

ENGINE REGIME		OPERATING RPM 500-2680	TAKE OFF RPM 2750	OVERLIMITED RPM 2860-3025	ENGINE TEST
Oil temp.	°C	normal. 40÷80 max. 85 for 10 min.	max. 85 for 10 min.	max. 85	min. 25
	°F	normal 104÷176 max. 185 for 10 min	max. 185 for 10 min.	max. 185	min. 77

Cylinder head temperature

--		Normal oper. range	Take off & climbing	Overlimited RPM	By descent
Cyl. Head temp.	°C	140÷185	max. 210 for 5 min.	max. 210	min. 70
	°F	284÷365	max. 410 for 5 min.	max. 410	min. 158

For prevention of overlimited max. oil or cylinder-head temperature before prescribed time limit the engine regime must be changed and the engine cooled for prescribed value.

Note: Above mentioned power values, RPM and boost pressure are made by engine in standard ISA conditions, it means by 15°C atmosphere temperature outside and 760 mm Hg pressure. By high atmospheric temperature or low pressure makes the engine lower boost pressure, lower output and RPM is higher. By low temperatures gives the engine lower RPM, but output and boost pressure is higher. In this case open the intake only to max. permitted boost pressure value.

2. OPERATING LIMITATIONS

- a/ **Max. take – off** is limited for max 5 min.
(by M 332 and M 337 family – supercharger engaged)
- b/ **Permitted RPM overlimit:**
RPM max. 2860 by boost pressure 100 kPa (29.5 inHg; 14.5 PSI)
(by M 332 and M 337 family – supercharger engaged).
Time limit: 30 sec.
By overlimit of these RPM and time limits check cylinder compression and valve clearance with records into the Engine Log-Book.
- c/ **Max. Indicated RPM:**
RPM max. 3025 by boost pressure 100 kPa (29.5 inHg; 14.5 PSI).
(by M 332 and M 337 family – supercharger engaged).
Time limit: 1 sec.
By overlimit of these RPM and time limits check cylinder compression and valve clearance with records into the Engine Log-Book.
- d/ **In emergency is permitted to use:**
Max. take – off power for 10 min. is allowed in respect to following conditions:
- operation engine values will not exceed limits;
- exceptional use of max. take off power has to be noted – recorded in Engine Log-Book
- e/ **Temperature limitations:**
M 332, M 337, M 137, M 132 family engines operation is permitted by meteorological conditions: temperature -40°C ÷ +40°C and moisture content 35 – 100% up to the height 6000m ISA.

Aerobatic operation restrictions:

M332A, M337A – elementary aerobatics permitted, fully aerobatics prohibited, inverted flight – max. – 5 sec., by aerobatics is permitted to engage the supercharger, only if you do not exceed max. continuous regime.

M332AK, M337AK – elementary aerobatics permitted, fully aerobatics prohibited, inverted flight without limit, by aerobatics is permitted to engage the supercharger, only if you do not exceed max. continuous regime.

M137A, M137AZ – full aerobatics permitted, inverted flight without limit.

M132 A – elementary aerobatics permitted, fully aerobatics prohibited, inverted flight – max. – 5sec.

M132 AK – elementary aerobatics permitted, fully aerobatics prohibited, inverted flight without limit.

Operation "g" overloading restrictions for all mentioned engines:

By all engines

$$n_y = +6g, -3,5g, \omega_{max} = 2 \text{ rad/sec.}$$

3. ENGINE POWER CHARACTERISTIC

Engine power characteristic are described on following pages.

Altitude performance
Without supercharger

M 332A, AK
M 132A, AK

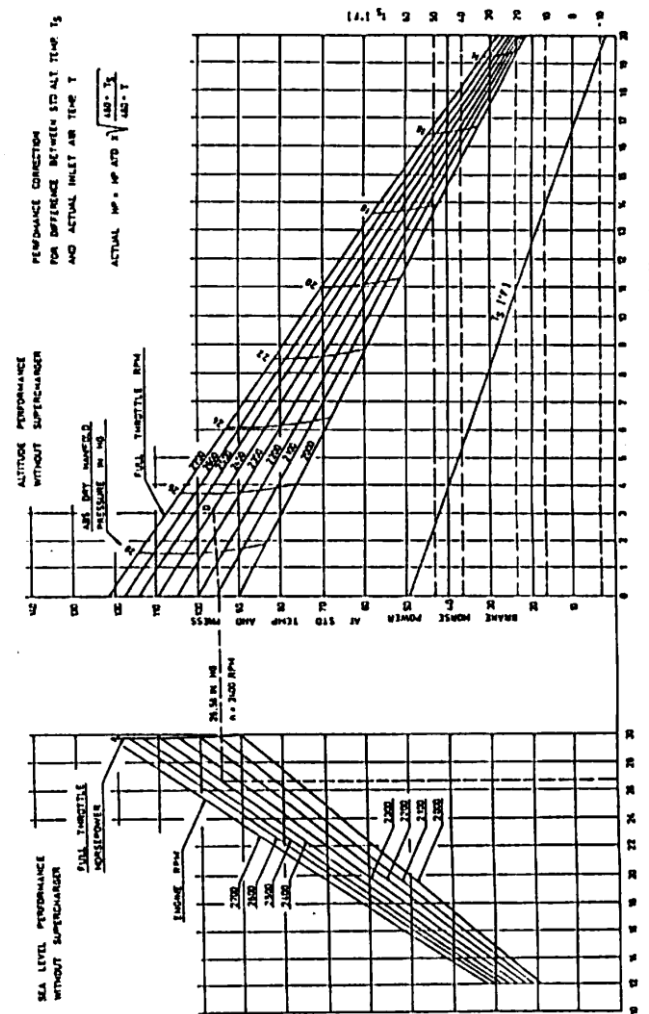

Obr. 3-1

Sea level performance
Without supercharger

Altitude performance
with supercharger

M 332A, AK

Sea level performance
with supercharger

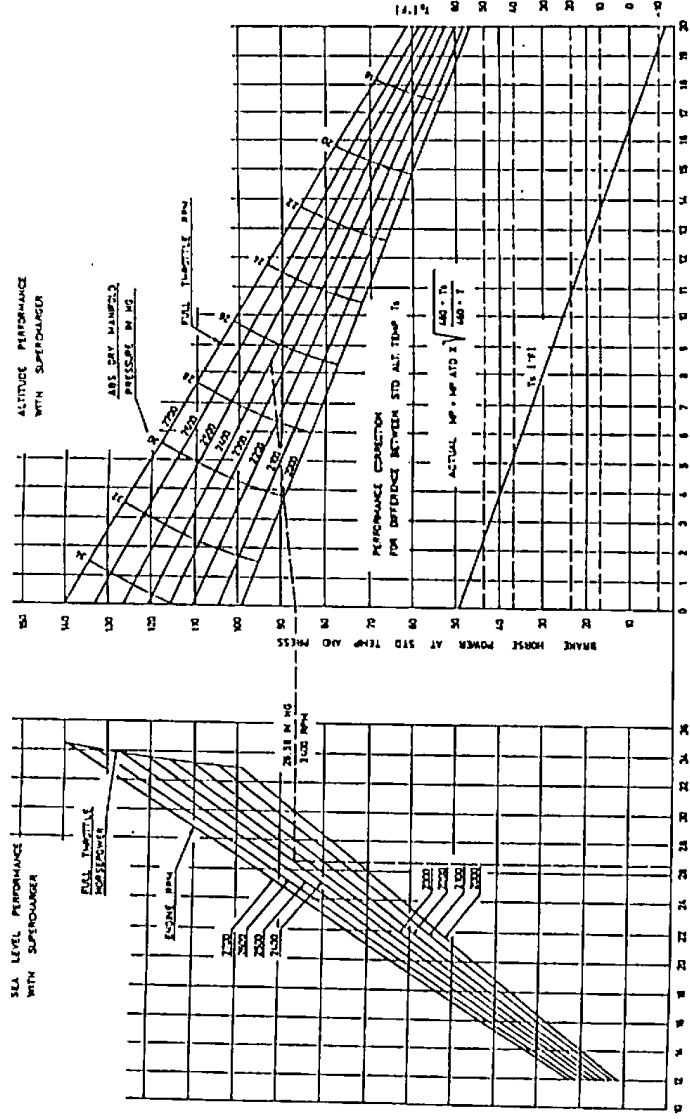

Obr. 3-2

Sea level performance
without supercharger

M 337A, AK
M 137A, AZ

Altitude performance
without supercharger

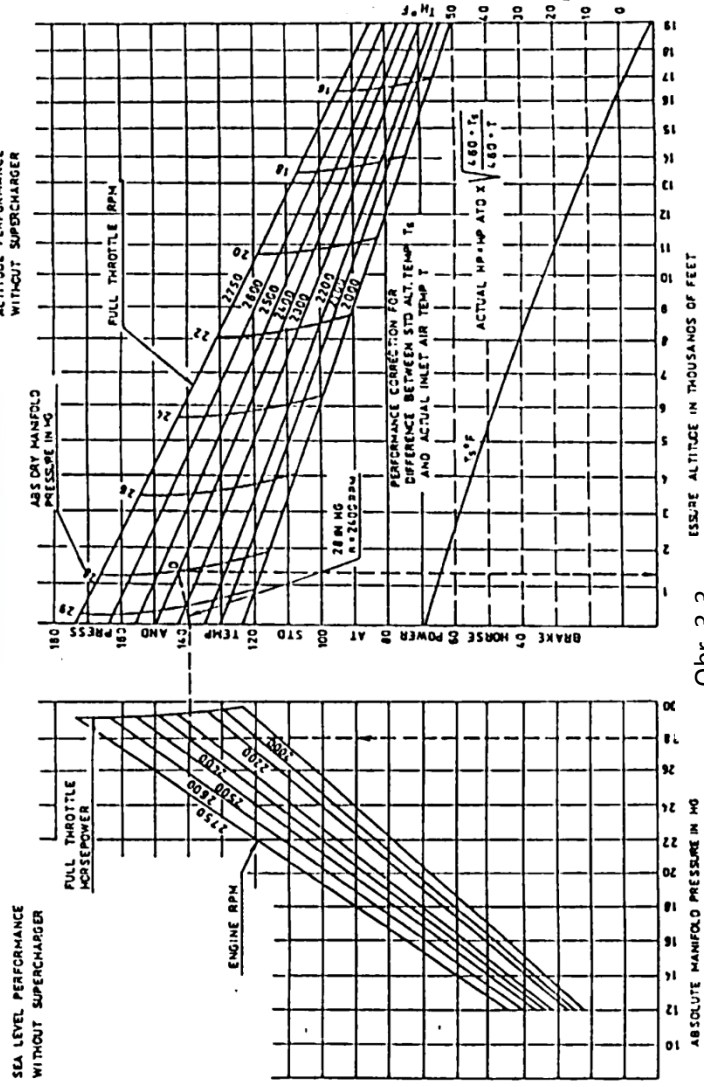

Obr. 3-3

Altitude performance
with supercharger

M 337A, AK

Sea level performance
with supercharger

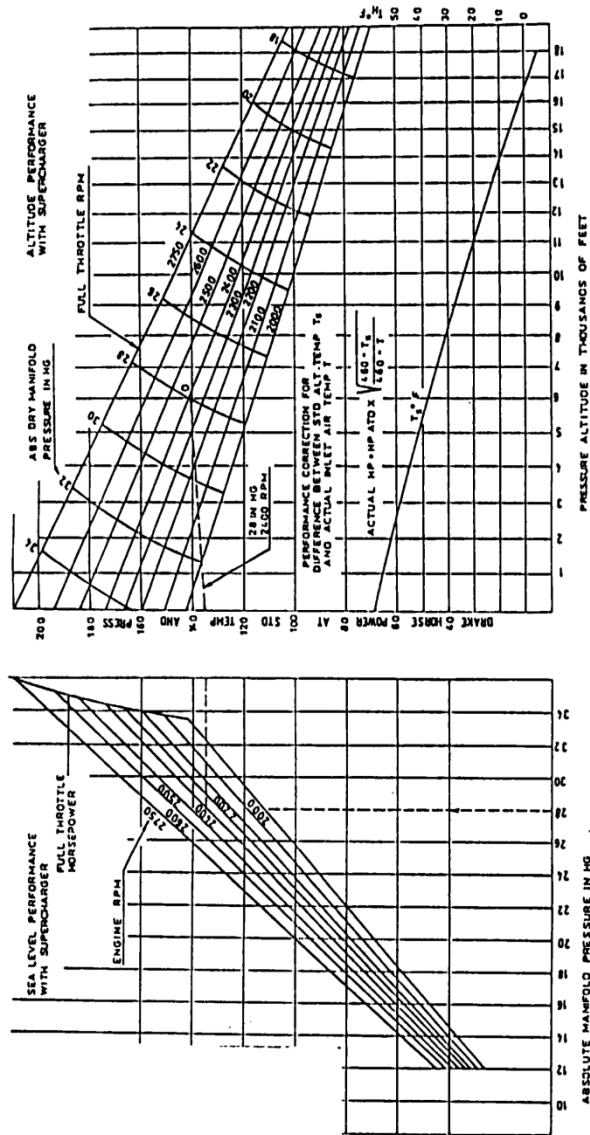

Obr. 3-4

4. THEORETIC VALVE TIMING

- C' shaft sense of rotation while viewing engine from front
- Theoretic valve timing while intake and exhaust valve clear.
Is 0.25 mm (0.0098 in)

Fig 3-5

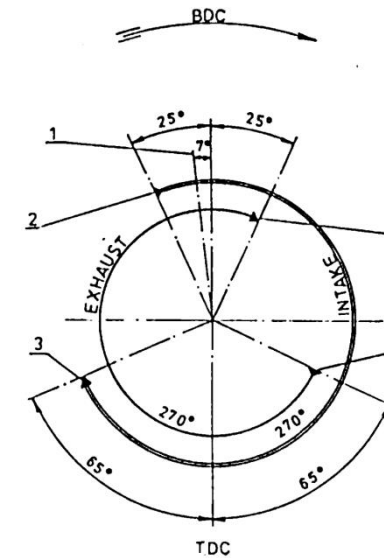

- | | |
|-------------------------|-------------------------|
| 1- Basic Magneto Timing | 4- Exhaust Valve Closes |
| 2- Intake Valve Opens | 5- Exhaust valve Opens |
| 3- Intake Valve Closes | |

SECTION 4

OPERATING SUBSTANCES

1/ Fuel4-2

2/ Lubricating oils and grease4-2

3/ Protective oils4-3

1. FUEL

To burn in the engine, a low lead min. 78 fuel octane grade is designated. Superior octane grades are not prohibited, provided that the TEL content is not greater than 0.06% parts per volume (2.27 ml TEL/US gal.).

Recommended fuel: It must meet the MIL G-5572-F prescriptions.

Octane Grande Coloration (in compliance with MIL): Red.....80/87
Blue.....91/96

Actual recommended fuels: ESSCO ICP 80
SHELL Avgas 80
SHELL Avgas 100 LL
BP 100 L
BL 78 CSN 65 6510

2. LUBRICATING OILS AND GREASE

For the operation of the engine it is necessary to utilize mineral oil of minimum kinematic viscosity of 20 mm²/sec at 100°C if its carbonizing residue does not exceed the value of 0.29 per cent of the matter.

SAE 50 type straight mineral oil is recommended to be used during engine run-in for max. 10 hours operation time. During engine run-in, it is not favourable to use additive oils (ashless dispersant), because of the presence of additives increasing the oil lubricating property. This property is not desired during engine run-in, because it prevents engine reciprocating parts break in.

Aircraft engine recommended oils:

Run-in: AEROSHELL Oil 100 (MIL-L-6082E, GRADE 1100),
AEROSHELL Oil 120 (in tropical regions)
Elf Aviation 100
Total Aero 100
Mobil Aero Red Band
MS-20 (GOST 21743-76)

Normal operation: AEROSHELL Oil W 100
 AEROSHELL Oil W 120 (in tropical regions)
 ELF Aviation AD 100
 MOBIL Aero Oil 100
 BP Aero D 100
 CASTROL Aero AD 100
 TOTAL Aero D 100

The used oils must comply with MIL-L-22 851D specifications.

Attention: *The oils change period during normal operation is maximum 200 flight hours, but minimum 1x12 month.*

Grease:

Magneto cam greasing oil: AEROSHELL T03

Control cantilever greaser: AEROSHELL Grease 14 (MIL-G-25537 C)

Greasing compound for starter housing: AEROSHELL Grease 14 + Engine oil
 (mixing ratio 2:1)

Page without text

3. PROTECTIVE OILS

The protective oils must comply with MIL-L-6529 C type 1 specifications.

Recommended protective oils: EXXON Rust Ban 631
 AEROSHELL Fluid 2XN

SECTION 5

OPERATION INSTRUCTIONS

1/ Engine controls5-2

2/ Engine starting procedure5-2

 a/ Starting at 5°C ÷ 20°C (41°F ÷ 68°F)

 air temperature5-2

 a/ Starting at air temperature

 greater than 20°C (68°F)5-3

 c/ Starting hot engine after flight5-3

 d/ Starting at -15°C ÷ 5°C (5°F ÷ 41°F)

 air temperature5-3

 e/ Starting at air temperature

 below – 15°C (5°F)5-4

3/ Engine warm-up5-4

4/ Engine test5-5

 a/ Propeller operation test5-5

 b/ Engine operation test5-5

5/ Operating in flight5-7

6/ Fuel consumption check for

 Z-142 aircraft mounted M 337 A/AK5-9

7/ Engine run-in following cylinder-piston

 group part replacement5-13

1. ENGINE CONTROLS

The engine running is controlled by the following means.

- ignition switch on and off;
- throttle control;
- mixture control;
- saturator (by engines equipped with automatic correction injection pump);
- supercharger control – engaging and disengaging (only for 332 and M 337 series);

The hydraulically actuated, variable pitch propeller is governed by the pertinent control item in the domain ranging from minimum pitch (maximum speed) to maximum pitch (minimum speed).

2. ENGINE STARTING PROCEDURES

Before engine starting, switch on check units for engine operation, turn on fuel cock, prim fuel system actuating the manual priming pump several strokes until 20 ÷ 30 kPa (2.9 ÷ 4.35 lbs./sq.in.) fuel pressure is indicated, set propeller governor in minimum pitch position (full RPM), engage supercharger, switch off magnetos.

2a. Starting at 5°C ÷ 20°C (41°F ÷ 68°F) air temperature

Throttle control	-1/2 of travel
Mixture control	-basic setting (-2 increments from N) or saturator closed
Priming	-2 strokes with the priming pump
Propeller rotation	-2 ÷ 4 turns (switch off magnetos !!)
Ignition	-switch on magneto selector
Starting	-press starter button

After engine started, set throttle to 1000 RPM. Check oil pressure gauge for indication. If min. 120 kPa (17.4 lbs./sq.in.) oil pressure is not indicated within ten seconds, stop engine and determine trouble.

2b. Starting at air temperature greater than 20°C (68°F)

- Throttle control -in position corresponding to 1000 RPM
- Mixture control -basic setting (-2 increments from N) or saturator closed
- Priming -max. 1 stroke
- Propeller rotation -2 turns, heed great attention (switch off magnetos !!)
- Ignition -switch on magneto selector

Engage starter. If failure, try again with the same throttle setting (corresponding to 1000 RPM). If failure again, set throttle control to 1/2 of travel. If starting attempt fails, this indicates that engine is overflowed by fuel and it is necessary to cease starting for a while and await until fuel in excess in the air inlet system evaporates. Than attempt engine starting without priming and throttle control setting in 1000 RPM position.

2c. Hot engine starting after flight

- Throttle control -1/2 till 3/4 of travel
- Mixture control -basic setting (-2 increments from N) or saturator closed
- Priming -without
- Do not rotate propeller -danger of accidents !!!
- Ignition -switch on magneto selector

Engage starter. If engine fails to achieve starting, it is necessary to let engine cool.

2d. Starting at -15°C ÷ 5°C (5°F ÷ 41°F) air temperature

If ambient air temperature decreases at -15°C ÷ 5°C (5°F ÷ 41°F), it is recommended to preheat engine and oil in oil tank by means of hot air. The hot air temperature should not exceed 120°C (248°F). Perform preheating until indicated cylinder head and oil temperature reaches 25°C (77°F). The battery must be out of the preheated area. Proceed further as indicated by the Starting at 5°C ÷ 20°C (41°F ÷ 68°F) air temperature procedure. At lower air temperatures, moderately reach mixture or saturator open (if equipped).

2e. Starting at air temperature below -15°C (5°F)

If ambient air temperature decreases below -15°C (5°F), it is necessary to preheat engine and oil in oil tank by means of hot air, and continue-see 2d.

***Attention:** Engage starter during engine start attempt for maximum 10 sec at once, followed by a 30- second long pause. It is permitted to engage starter three times during one engine start attempt and than is necessary to let starter electromotor cool. It is not permitted to engage starter while engine running, or to leave it engaged after engine started.*

3. ENGINE WARM-UP

Let cold engine to idle at 1000 RPM for one to two minutes and as soon as engine runs smoothly, disengage supercharger. After one to two minutes (this period may be longer during cold weather) engine running, slowly increase speed to 1500 ÷ 1600 RPM. If RPM increasing is achieved with insufficiently warmed-up engine, oil pressure drop can result. In this case, decrease RPM to an indication at which the prescribed 350 ÷ 400 kPa (51 ÷ 58 lbs./sq.in.) oil pressure is evidenced and then progressively increase RPM to 1500 ÷ 1600. The minimum oil pressure indication is 350 kPa (51 lbs./sq.in.). Maintain these RPM until engine warm-up for engine test is achieved. Warmed-up engine minimum indications before engine test are:

cylinder head temperature	min. 120°C (248°F)
oil temperature min.	25°C (77°F)
oil pressure min.	350 kPa (51 lbs./sq.in.)

The lower is the ambient air and oil in tank temperature, the more thoroughly and longer must be engine warm-up. It is not permitted rapid RPM increasing after engine start. Abrupt oil temperature increase or oil pressure drop during engine warm-up is evidence of engine trouble.

After engine warm-up and before engine test, perform generator and regulating relay test. The RPM increasing to 1800 must cause the red control

lamp on the instrument panel indicating battery charging to go off. Meanwhile, the VA-meter must indicate $26 \div 28$ V.

Attention: While warming-up engine, rapidly change RPM settings at which the engine falters or does not run smoothly.

4. ENGINE TEST

Perform engine test after the engine was warmed-up

a. Propeller Operation Test

Mixture control	-see table on page 5-7; saturator closed;
Manifold pressure	-according to cruise rating (see SECTION 3);
Supercharger	-disengaged;
Propeller control	-move propeller control 2 or 3 times trough its complete range, i.e. between minimum and maximum blade angle setting.

b. Engine Operation Test

1/ Engine regime – Max. continuous

Throttle control	-M 337 A/AK, M 332 A/AK – complete travel; -M 137 A/AZ, M 132 A/AK – according to cont.regime;
Supercharger	-disengaged (M 337, M 332 family);
Mixture control	-see table on page 5-7; saturator closed;
Propeller control	-min. blade angle setting;
RPM	-according to max. cont. regime (see SECTION 3);
Boost pressure	-according to max. cont. regime (see SECTION 3);
Fuel pressure	-30 ÷ 40 kPa (4.4 ÷ 5.8 PSI);
Oil pressure	-350 ÷ 400 kPa (51 ÷ 58 PSI);
Oil temp. (inlet)	-min. 25°C (77°F), max. 80°C (177°F);
Cyl. Head temp.	-min. 120°C (248°F), max. 185°C (365°F)

Magneto Check (M 332, M 337 family):

Switch to each magneto and note drop-off. Prescribed drop-off is 30 ÷ 50 RPM. If prescribed drop-off is not observed, it is necessary to time

magneto to engine in compliance with the procedure in SECTION 7. This engine test is limited to 20 seconds.

2/ Engine regime – Max. take-off

Throttle control	-complete travel;
Supercharger	-engaged (M 332, M 337 family);
Mixture control	-see table on page 5-7; saturator closed;
Propeller control	-min. blade angle setting;
RPM	-according to take-off regime (see SECTION 3);
Boost pressure	-according to take-off regime (see SECTION 3);
Fuel pressure	- 40 ÷ 45 kPa (5.8 ÷ 6.5 PSI);
Oil pressure	- 400 ÷ 450 kPa (58 ÷ 65 PSI);
Oil temp. (inlet)	-min 25°C (77°F), max. 85°C (185°F);
Cyl. Head temp.	-min. 120°C (248°F), max. 210°C (410°F);

Magneto Check (M 137, M 132 family):

Switch to each magneto and note drop-off. Prescribed drop-off is 30 ÷ 50 RPM.

Perform propeller operation test:

Move propeller control to max. blade angle position.

RPM -according to propeller oper. manual

Move back propeller control to min. blade angle position.

RPM -according to propeller oper. Manual

This engine test is limited to 10 sec.

3/ Engine regime - Idling

Throttle control	-idle setting;
Supercharger	-disengaged (M 332, M 337 family);
Mixture control	-see table on page 5-7; saturator closed;
Propeller control	-min. blade angle setting;
RPM	- 500 ÷ 600;
Boost pressure	-not indicated;
Fuel pressure	-min. 10 kPa (1.45 PSI);
Oil pressure	-M 337, M 137 family-min. 120 kPa (17.4 PSI); -M 332, M 132 family-min. 220 kPa (31.9 PSI);
Oil temp. (inlet)	-min. 25°C (77°F);
Cyl. Head temp.	-min. 120°C (248°F).

This engine test is limited to 5 min.

Engine running during the entire engine test should be smooth. All prescribed indications should be observed. Do not operate the engine on one magneto for too long time. Spark plug fouling problems are minimized.

5. OPERATING IN FLIGHT

If all instrument indications are within the prescribed limits, mixture control in basic position or saturator closed, propeller control set to minimum blade angle (maximum RPM) position, fully open throttle to take off, while the supercharger is engaged - for M 332 and M 337). Engine speed and the manifold pressure should not exceed the values of max. take-off power rating prescribed in SECTION 3. The take-off rating is limited to 5 minutes provided that cylinder head and oil temperature do not exceed maximum operation value. If these values are exceeded, change to maximum continuous power rating and cool engine. As a rule, a shorter interval than five minutes is enough to climb to the safe ceiling above obstacles situated around the airfield. Climbing may be than continued at maximum continuous power rating with engaged supercharger and without time limitation, providing that the manifold pressure, the engine speed, cylinder head temperature and the oil temperature do not exceed the values of max. continuous power rating prescribed in SECTION 3. If these values are exceeded, stop climbing and cool engine in horizontal flight.

Increasing elevation causes that mixture begins to turn lean and engine roughness is evidenced. It becomes necessary to enrich mixture with a mixture control lever until engine runs smoothly according to the following chart.

Chart 5-1

ELEVATION	INJECTION PUMP CORRECTION LEVER POSITION
0 meters (0 ft.) ASL	end position
800 meters (2625 ft.) ASL	+ 1 increment to end stop
1600 meters (5250 ft.) ASL	+ 2 increments to end stop
2600 meters (8530 ft.) ASL	+ 3 increments to end stop
3700 meters (12140 ft.) ASL	+ 4 increments to end stop
Mixture correction is not needed over 3700 m (12140 ft.) elevation	

During descent, it is necessary to bring back the mixture control to the basic setting. By engines equipped with injection pump LUN5150.03 and LUN5151.03 with automatic correction of fuel mixture, correction passes automatically without pilot's intervention. Finishing climbing, a horizontal flight may follow. Flight ratings with pertinent engine power ratings are shown in the airframe manufacturer's manual. During engine flight operation, check instruments for RPM, pressure and temperature indications. All prescribed indications should be observed. Do not actuate abruptly the throttle control. The engine run should be smooth, without faltering and stops within the entire RPM range. Oil pressure drop beneath rated oil pressure value is evidence of a serious oil system trouble and therefor it is necessary to land immediately and determine the trouble.

By aerobatics be careful about restrictions noted in section 3. Inverted flights are permitted only with model M 132 AK, M 332 AK, M 137 A/AZ and M 337 AK. With the others models it is limited, because these models do not possess an oil system adapted for inverted flights.

The minimum cylinder head temperature during descent is 70°C (158°F).

If engine is overcooled, it is necessary to enrich moderately mixture (for maximum one or two injection pump dial increments). During longer descent while cylinder head temperature is decreasing, it is necessary to set sometimes aircraft in horizontal flight and rewarm engine so that cylinder head temperature does not decrease below 70°C (158°F). Before landing, especially during cold weather, it is necessary to warm up engine to minimum 100°C (212°F), engage supercharger and move propeller control to minimum blade angle position (if not previously performed) and prepare in this way the engine for take-off rating in case that landing is aborted. Following landing, disengage supercharger, slowly cool engine until cylinder head temperature indicates 120°C (248°F) and shut down engine while idling. If self-ignition is evidenced after magnetos are cut off, it is possible to enrich mixture for two or three increments achieving in this way a more rapid engine cooling and cut off magnetos again after a short time run. If the engine is equipped by saturator it is possible to enrich the mixture by saturator.

By taxiing it is permitted to use engine run with supercharger on, but before engine stop must be supercharger switched off.

To reach maximum ground speed in horizontal flight, it is permitted to apply maximum take-off rating for five minutes, provided that prescribed temperature indications should not be exceeded.

Partial throttle open when supercharger is engaged, it is not favorable because of increased fuel consumption, but it is necessary when the supercharger should be engaged during low altitude flights.

6. FUEL CONSUMPTION CHECK FOR Z-142 AIRCRAFT MOUNTED

M 337 A/AK

The fuel consumption check is to be performed when it becomes doubtful. Before this, it is necessary to check engine for:

- a/ proper magneto timing and condition;
- b/ spark plug condition;
- c/ valve clearance condition. Adjust clearance if necessary;
- d/ manifold pressure gauge adjustment;

Perform engine test according to the procedure in this SECTION.

Verify RPM drop by switching to each magneto. RPM drop should range between 30 and 50.

Verify fuel pressure during cruise rating. It should range between 35 to 40 kPa (5.1 ÷ 5.8 lbs/sq.in.).

a. Refueling aircraft before test flight

Place aircraft on straight area. Place airplane in a level flight attitude and mark landing gear wheel positions.

Fill with fuel until the brim only the main left and right fuel tank. Leave the auxiliary fuel tanks empty.

b. Fuel consumption check during flight

Perform engine start, taxiing, take-off, climbing and horizontal flight approach at cruise rating feeding engine only from the right fuel tank.

Flight and engine rating

- Flight elevation - 300±50 m (985±165 ft.);
- Boost pressure - 90 kPa (26.6 inHg; 13.05 lbs/sq.in.);
- RPM - 2400;

- Supercharger - disengaged;
- Fuel pressure - 35 ÷ 40 kPa (5.1 ÷ 5.8 lbs./sq.in.);
- Mixture control - basic setting; saturator closed;
- Measure and record air temperature at 300 ± 50 m (985 ± 165 ft.) elevation.

c. Fuel consumption measuring:

While flying horizontal flight, switch fuel tank selector to the left tank and concomitally start chronometer to measure time. The measured flight interval is 30 minutes. The pilot should watch the correctness of the selected rating and record requested data:

- the fuel pressure (precisely);
- the inlet air temperature.

After 30 minutes flight interval elapsed, switch fuel tank selector to the right tank and land. After landing, place aircraft in the same position, marked before refueling and place back in a level flight attitude. Refill precisely the left tank with fuel until the same fuel level and notice the fuel quantity the tank was refilled with.

To perform computation, it is necessary to know the fuel pressure and the returned fuel quantity such as the fuel consumption tolerance (ranging).

Fuel consumption tolerance vs. inlet air temperature table

AIR INLET TEMPERATURE		FUEL CONSUMPTION TOLERANCE	
°C	°F	lit/hr.	US.gal./hr.
-10	14	43,7	11,55
		45,8	12,10
-5	23	43	11,36
		45	11,89
0	32	42,2	11,15
		44,2	11,68
+5	41	41,4	10,94
		43,5	11,49
+10	50	40,7	10,75
		42,7	11,28
+15	59	40	10,57
		42	11,10
+20	68	39,3	10,38
		41,3	10,75
+25	77	38,7	10,23
		40,7	10,75
+30	86	38,1	10,07
		40	10,57
+35	95	37,5	9,91
		39,4	10,41
+40	104	36,9	9,75
		38,8	10,25

FUEL PRESSURE		MNOŽSTVÍ VRATNÉHO PALIVA			
kPa	lbs./sq.in.	within 30 min.		within 1 hr.	
		lit.	US gal.	lit.	US gal.
35	5,075	10,00 ±1,00	2,642 ±0,264	20,00 ±2,0	5,284 ±0,528
36	5,220	10,28 ±1,00	2,716 ±0,264	20,56 ±2,0	5,432 ±0,528
37	5,265	10,56 ±1,05	2,790 ±0,277	21,12 ±2,1	5,580 ±0,555
38	5,510	10,84 ±1,05	2,864 ±0,277	21,68 ±2,1	5,728 ±0,555
39	5,655	11,12 ±1,10	2,938 ±0,290	22,24 ±2,2	5,876 ±0,581
40	5,800	11,40 ±1,15	3,012 ±0,304	22,80 ±2,3	6,024 ±0,608

d. Sample Fuel Consumption Computation

The sample computation is achieved with the following assumed data:

- fuel pressure during flight: 35 kPa (5.1 lbs./sq.in.)
- inlet air temperature at 300m (984.24 ft.) altitude: 15°C (59°F)
- fuel quantity refueled in the left tank: 31 lit. (8.19 US gal.)
- fuel quantity returned to the right tank within 30 min.: 10 lit. (2.642 US gal.)
(this value is given in the table)

The actual fuel consumption:

- 31 lit. (2.19 US gal.) -fuel qty. refueled;
 - 10 lit. (2.642 US gal.) -returned fuel qty.
 - 21 lit. (5.548 US gal.) -fuel consumption per 30 min.
- that means 42 lit. (11.096 US gal.) per hour.

The fuel consumption is within tolerance, see fuel consumption tolerance vs. inlet air temperature table.

7. ENGINE RUN-IN FOLLOWING CYLINDER-PISTON GROUP PART

REPLACEMENT

After engine reassemble, install propeller and perform engine run-in with flight operational propeller.

Start engine in compliance with the procedure indicated in this SECTION.

Engine run-in procedure:

RPM	Interval	Supercharger M332, M337 series only
start	5 minutes - warning	engaged
800	10 minutes	disengaged
1000	5 minutes	disengaged
1100	5 minutes	disengaged
1400	5 minutes oil inlet temp. min 25°C (77°F)	disengaged
1600	5 minutes	disengaged
1800	5 minutes	disengaged
2000	5 minutes	disengaged
2200	5 minutes	disengaged
2400	10 minutes	disengaged
2600	20 sec.	disengaged
2700-100	10 seconds - cyl. Head temp. max 210°C (410°F)	engaged
2400	10 minutes	disengaged
2600	20 sec.	disengaged
2700-100	10 seconds – cyl. Head temp. max. 210°C (410°F)	engaged
900 ÷ 1100	10 minutes - cooling	disengaged
500 ÷ 600	stop	disengaged
Total time 81 min.		

All prescribed pressure and temperature indicators, show in the specifications in SECTION 3 of this manual, should be observed during engine run-in procedure. It is favorable to apply the max. take-off and max. continuous power rating for as short as possible periods during the first 10 hours operation time.

SECTION 6

PERIODIC INSPECTION

1/ General 6-2

2/ Pre-Flight-check 6-2

3/ Between-Flight-Check 6-4

4/ After-Flight-Check 6-4

5/ 10 ± 1 Hour Inspection 6-5

6/ 50 ± 5 Hour Inspection 6-6

7/ 500 ± 10 and 1,500 ± 10 Hour Inspection 6-8

8/ 1000 ± 10 Hour Inspection 6-10

9/ Partial Inspection 6-13

10/ Non-Scheduled Inspections 6-17

11/ Operating limits till overhauls, service life,
 number of overhauls 6-17

1. GENERAL

The basic factor for preserving engine performances and reliability is the conscientiously observing of the prescribed procedures during inspections. Neither the perfect system of inspections can eliminate the influence of the human element upon the accuracy the prescribed procedures are being performed with. Hence the necessity, that the operator should pay maximum heed to all kinds of inspections, in order to minimize the risk of unsafe events.

The works required by the Pre-Flight, Between-Flight and After-Flight Checks, as well as by the 10-Hour and 50-Hour Inspections may only be performed by a pilot or mechanic, who possesses a license issued by the Aviation Authority for care of the particular aircraft type.

The works involved by the 500-Hour Inspection, which extend the volume of the 50-Hour inspection, may only be performed by a mechanic of the manufacturer or trained and certified by approved organization.

Attention: *Beside the inspections in this manual, it is necessary to observe all kinds of inspections and maintenance procedures prescribed by the airframe manufacture in the pertinent Aircraft Operator's Manual.*

2. PRE-FLIGHT CHECK

The Pre-Flight Check serves to verify the general condition of the engine for flight. It is carried out before the first flight of the day.

- a/ Check oil level in the tank and add if necessary. The tank should not be completely full. Above the oil level it has to remain an empty volume-about 20% of the tank whole volume-for the case of oil foaming. The minimum quantity of oil in the tank should be enough for the planned flight, considering the greatest oil consumption plus to keep about 5 liters (5.3 US qts) of oil by M 332/M 132 engines and 7 liters (7.4 US qts.) of oil by M 337/M 137 engines, as the minimum quantity, which is necessary for oil circulation.

Attention: During lower ambient temperature, it is necessary to preheat the engine and oil to min. 25°C (77°F), so that the oil can be surged during starting. The oil may be also preheated by means of an electrical heater, if the tank is provided with. Preheat the engine with respect to the ambient temperature and according to the prescription in the Aircraft Operator's Manual.

- b/ Check oil lines for leaks. If there is a cock along the inlet lines, OPEN IT!
- c/ Check fuel quantity in the tank and refuel if necessary. Open fuel drain to remove water accumulation and sediment. After priming fuel in the fuel system by means of the hand operated priming pump, check fuel strainers for leaks caused by improper assembling. Check minutely all fuel lines.

Note: Refuel only from certified sources equipped with systems removing condensed water and dirt. In case of forced refueling directly from barrels, avoid admission of condensed water and dirt into the engine fuel system.

Attention: Observe specific safety prescription during refueling!

- d/ Check ignition system and verify if proper connection of the conductors to the spark plugs, if the proper connection of the magnetos short-circuit conductor and if the magnetos selector switch is in the OFF position. Check electric cable shielding for free of damage, free of dirt and grease.

Attention: The flight safety and maintenance personnel security depend upon the proper functioning of these instruments and upon the position of magneto selector switch during the manual rotating of propeller.

- e/ Check engine controls for proper operation: throttle linkage, mixture control supercharger drive control and fuel control.
- f/ Check RPM indicator drive.
- g/ Visually check engine for general condition, evidence of dirt and accessories condition for non-loose and secured connections and mounting
- h/ Manually rotate the crankshaft several turns, while ignition is "OFF" and check compression in each cylinder. If evidence of considerable difference between cylinders, perform compression test according to SECTION 7 of this manual. Turn the crankshaft in described direction.

Note: If very cold weather, rotate crankshaft more turns, so that the bearings be flooded by warm oil and decrease resistance during starting.

- i/ Minutely check propeller for tight and secure mounting and engine for proper mounting.
- j/ Set main fuel cock and other eventual selector cocks in the fuel system in "ON" position, according to airframe manufacturer's prescriptions.

3. BETWEEN-FLIGHT CHECK

The Between-Flight Check is carried on during the flight day between one landing and the following take-off. If repeated short flights are performed (such as circuits), this check can be carried on at an interval of 2 flight hours.

- a/ Check oil system for leaks.
- b/ Check fuel system for leaks.
- c/ Check oil and fuel level, add and refuel if necessary.

4. AFTER-FLIGHT CHECK

The After-Flight Check is carried on after the last flight of the day. It serves to make a comparison with the engine condition evidenced during the Pre-Flight Check.

- a/ After engine shut-down, check engine cowlings and open them, externally clean engine, accessories and airframe in the engine's vicinity.
- b/ Check fuel system for leaks and secured connections.
- c/ Check oil system for leaks and secured connections.
- d/ If evidence of exhaust seepage, repair damaged elements.
- e/ Check engine controls for condition and securing.
- f/ Check electrical wiring for condition and proper anchorage.
- g/ Compare fuel and oil consumption with pertinent data in SECTION 3 of this manual.

5. 10±1 HOUR INSPECTION

This inspection is carried on after the first 10 hours operation time on new and overhauled engines and on engines at which parts belonging to the piston-cylinder group were replaced during operation period.

- a/ Perform engine check according to the procedure indicated in SECTION 5 of this manual.
- b/ Drain oil from the tank, engine, oil lines and injection pipe through a fine sieve. Check evidence of metal particles. If positive, the engine has to be inspected by specialist from engine's manufacturer or a repair shop authorized by him. Renew oil in compliance with the procedure indicated in SECTION 7 of this manual.
- c/ Remove, check and clean the oil strainers and screens from the:
 - oil tank;
 - oil pump;
 - oil sump;
 - camshaft drive gear housing.
- d/ Reassemble oil strainers and screens and refill oil system with oil according to SECTION 4 of this manual.
- e/ Check 24.5 Nm (18.1 ft.lbs) torque tightening of the cylinder heads studs by means of a torque wrench. Perform tightening in accordance with the procedure in SECTION 7 of this manual.
- f/ Check valve clearance and adjust it if necessary according to the procedure in SECTION 7 of this manual.
- g/ Perform propeller flange nut tightening by tightening moment $M_k = 294 \div 343$ Nm (30 ÷ 35 kpm). Also see the manufacturer's propeller manual.
- h/ Perform engine test in compliance with the procedure in SECTION 5.
- i/ Enter performance of the 10-Hour Inspection in the engine log-book.

6. 50 ± 5 HOUR INSPECTION

This inspection is carried on after each 50th hour of flight operation or in respect to service bulletins issued manufacturer of engines.

- a/ Check engine according to the procedure indicated in SECTION 5 of this manual.
- b/ Open engine cowls and remove spark plugs on one side.
- c/ Measure compression pressure in each cylinder according to the procedure indicated in SECTION 7.
- d/ Check oil system according to items a. and b. from the 10-Hour Inspection. Perform check when oil still hot.
- e/ Unscrew plug and check the correction compartment of the injection pump for presence of oil. Drain oil if necessary. See Fig. 7-1 Detail "A".
- f/ Reassemble oil strainer and renew lubricating oil according to specifications in SECTION 7.

Attention: *During removing and reassembling the oil tank strainer, avoid deformation of the strainer and of the gravity valve through excessive tightening.*

- g/ Drain fuel in the tanks and strainers.
- h/ Remove, check and clean fuel strainers, injection pump strainer included. Perform extraction of the injection pump, fuel strainer in compliance with the procedure indicated in SECTION 7 of this manual.
- i/ Externally check injection pump for leaks.

Note: *Colored fuels leave colored spots after evaporation.*

- j/ Remove and clean injection nozzles.
- k/ Wash tanks internally, reassemble strainers, injection nozzles and refuel with new, prescribed grade fuel according to the specifications in SECTION 4.

Note: *Use fuel only from certificated sources equipped with systems for elimination of accumulated water and sediments.*

- m/ Check 24.5 Nm (18.1 ft.lbs) torque tightening of the cylinder head studs, according to procedure in SECTION 7. After this, reassemble covers at the lower part of the air scoop.
- n/ Check valve clearance adjustment, readjust if necessary according to procedure indicated in SECTION 7.
Cold clearances - intake valves 0.25 mm (0.0098 in.);
 - exhaust valves 0.40 mm (0.0157 in.).
- o/ Inspect magnetos according to 50-Hour and 100-Hour Inspection observing the procedure indicated in SECTION 7.
Breaker gap: 0.25 ÷ 0.35 mm (0.01 ÷ 0.014 in.).
- p/ Check and service starting vibrator after the first 50 hours and then after every 100 hours, according to the procedure indicated in SECTION 7.
- q/ Check and clean spark plugs according to procedure indicated in SECTION 7.
- r/ Service generator after 100 hour's flight operation time according to procedure indicated in SECTION 7.
- s/ Visually check and clean regulator relay and starter.

Note: *When charging current is normal, check only connectors and terminals. In case of malfunction (abnormal current), replace regulator relay.*

- t/ Check supercharger clutch adjustment according to procedure indicated in SECTION 7.
- u/ Inspect and service air strainer at the supercharger air intake according to procedures in the airframe manufacture's manual.
- v/ Check supercharger air intake ducts for airtightness, proper tightening of the blind nuts and visually check air inlet ducts for general condition and integrity, especially pay attention to welded seams. Repair or replace in case of damage.
- w/ Visually check and verify proper tightening of the exhaust stacks and collector connections and between different components of the exhaust system.

- x/ Perform tightening of the oil distributor (if applicable) and the propeller flange nut by tightening moment $M_k = 294 \div 343$ Nm (30 ÷ 35 kpm) according to procedure indicated in the manufacturer's propeller manual.
- y/ Check following nuts and parts for proper tightening and securing:
 - crankcase bolt and stud nuts;
 - engine mounting pins and bearings;
 - oil and fuel line ancillary elements;
 - attaching parts of the air scoop.
- z/ Clean engine and accessories from grease and dirt using adequate cleaning means.
- aa/ Inspect, clean check and grease all joints, guide pins and rods of the engine controls, i.e:
 - the main, mixture and supercharger levers;
 - the injection pump and throttle linkage.
 Renew grease in the greaser at controls cantilever according to specifications in SECTION 4.
- ab/ Perform engine test in compliance with the procedure indicated in SECTION 5.
- ac/ Check fuel and oil system for tightens and securing.
- ad/ Enter performance of the 50-Hour Inspection in the engine log-book.

7. 500 ± 10 AND 1,500 ± 10 HOUR INSPECTION

This inspection should be carried on after each 500 and 1,500 hour's flight operation time. It contains all the 50-Hour inspection works and the following items in addition:

- a/ Fly a test flight to verify fuel consumption. Established consumption value compare with data in SECTION 3 of this manual. If necessary, adjust injection pump according to the procedure in SECTION 7.
- b/ Check supercharger for condition according to the procedure in SECTION 7.
- c/ Perform 500-Hour Magneto Inspection in compliance with the procedure indicated in SECTION 7.
- d/ Service starter according to the procedure in SECTION 7.

- e/ Check control rods. Repair or replace if necessary.
- f/ Visually check ignition harness tube support and other wires for condition. Cable shielding to spark plugs may not be worn or torn to holes. Replace if evidence of damage. Visually check insulators and cable terminals for breaking, burning or piercing replace damaged insulators and cables.
- g/ Check internal surface of the air intake ducts for cleanliness and integrity.
- h/ Check throttle mechanism in its housing for general condition and proper functioning.
- i/ By engine equipped with injection pump with manual correction check basic position of the mixture control, which corresponds to the manual mixture control position, i.e. 2 increments from "N" position, which is marked on the injection pump mixture dial. See Fig. 6-1.

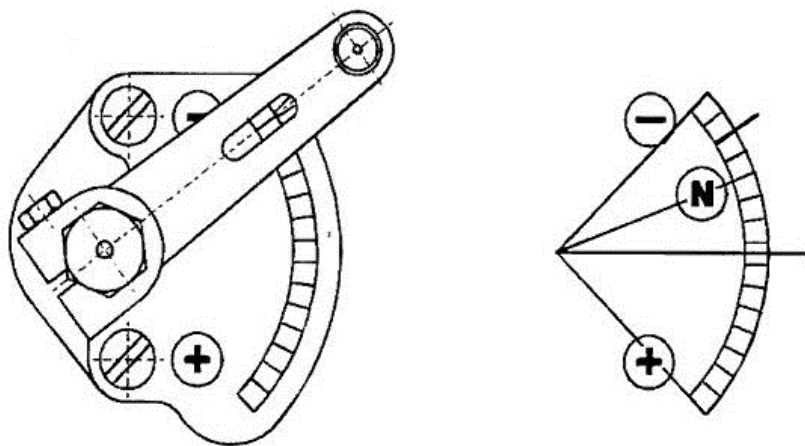

Fig. 6-1

- j/ Remove, check and clean oil strainer in the crankcase top lid.
- Note:** *Applicable for Model M137/AZ, M 337AK and M132AK only. Remove the strainer after the supercharger disassemble..*
- k/ Enter performance of the 500 or 1,500-Hour Inspection in the engine log-book.

8. 1000±10 HOUR INSPECTION

This inspection concerns engines, which obtained TBO more than 1,000 hours. This inspection is executed by every operation 1000 hours and concerns all the 50-hour inspection works and the following items in addition. This inspection is derived from M337A/9b and M337AK/4b bulletin. Works above the 50-hour inspection standard can be made just by a mechanic from engine's manufacturer or trained and certified by approved organization

- a/ Perform the testing flight for fuel consumption checking, according to section 5. Compare with section 5 data. In case of high consumption send the injection pump for repair to the engine manufacturer or authorized service.
- b/ Check the supercharger condition /see section 7/.
- c/ Execute the driving lever inspection and if necessary, execute replacement or parts repair /see section 7/.
- d/ Execute visual inspection of wire ramps and other wires. Shielding covering on wires to plugs may not be damaged. Replace damaged wires. Inspect insulators and ends of wires, if they are not broken, burnt or punching. Replace damaged wires and insulators.
- e/ Inspect the purity and not damaged internal surface of suction pipe.
- f/ Inspect the condition and function of air flap mechanism and air flap body.
- g/ By engine equipped with injection pump with manual correction check basic position of fuel enrichment, which is corresponding to manual correction lever position, it means value -2 graduation in "N" position on the injection pump correction scale. See picture 6-1.
- h/ Execute disassembly, inspection and purification of oil cleaner in the engine case cover.
- i/ If the operation limit of below mentioned engine aggs. is over, replace them with new or repaired with corresponding operation limit. Operation limit is marked in certificates of instruments in engine logbook. If avionics instruments have not life limit over, send them for repair.

Name	Marking	Note	Qty.
Ignition magnetos	LUN 2221.13	family M337, M137	2
	LUN 2225	family M332, M132	2
Starter el. motor	LUN 2253	family M337, M137	1
	LUN 2254	family M332, M132	1
Starting buzzer	LUN 2231	all family	1
Dynamo	LUN 2111, LUN 2111.1	all family	1
Voltage regulator	LUN 2141, LUN 2141.1	all family	1
Injection pump	LUN 5150, LUN 5150.01	family M337, M137	1
	LUN 5151.02	family M332, M132	1

Note: Injection pumps LUN 5150.03 and LUN 5151.03 with automatic fuel mix correction have operation time till O/H 2,000 hours.

j/ Replace parts mentioned in below following table, if where not replaced before.

Name	Marking	Note	Qty.
Rubber muff (sleeve)	Sh 6683	family M337/M137	2/1
Rubber muff (sleeve)	Sc 6618	family M337, M137 family M332, M132	1 1
Supercharger damper assy	Sc 0546	family M332, M337	7
Camcase parts rubber packing ring	1002371	family M337, M137	2
		family M332, M132	1
Piston compression rig	6-2860-03/4	family M337, M137	12
		family M332, M132	8
Piston scraper ring-upper	7-2860-02/4	family M337, M137	6
		family M332, M132	4
Piston scraper ring-lower	7-2860-01/4	family M337, M137	6
		family M332, M132	4
Sparking plugs	PAL L 22.62	family M337, M137	12
		family M332, M132	8
Injection nozzle	Yc-070	family M337, M137 family M332, M132	6 4
Oil pressured hose	Sc 0625	all eng. types	1

- k/ Visual checking of valve spring. In case of corrosion or crack –replace spring.
- l/ Check the tightness of exhaust and suction valves. If necessary, execute their grinding.
- m/ Purify and rinse with petrol gravity valve in oil pump.
- n/ Visual checking of ball bearing FAG 6211 MAP6F10A in crankcase front cover for corrosion defect incidence. Replace ball bearing with corrosion.
- o/ Visual check of cylinder head screws Sh 1025. Corrosion from cylinder head screws take-off without screw disassembly by emery, than polish the shank for original surface of screw shank must be smooth and not damaged. Superficial screw preservation make with varnish. Basic varnish by paint S2003, upper painting with enamel paint S2013. Minimal dia of screw after grinding off os 6.4mm. In case of less dia replace the screw with new one with abnormal thread because of necessary overhang the thread in engine case.
- p/ Check the surface of crank shaft in part before the bearing for cracks by crack detector with spray. In case of discovered cracks on crank shaft or cone - send engine for repair to the engine producer.
- q/ Disassemble the shaft case cover. Prevent in suitable way falling of foreign particles to the crank case space. Check technical condition of cavities blindings of stroking pins and tightening and securing of slotted nut screws of these blindings. Crack or corrosion on blindings is not permitted and is necessary to replace the blinding. In case of blinding replacement prevent in suitable way falling of foreign particles to the crank case space.
- r/ By engine parts replacement use only original parts from the engine producer.
- s/ By execution of prescribed works keep processes noted in section 7.
- t/ Shoot other troubles.
- u/ After engine assembly execute its running according to process described in section 5.
- v/ Inspection execution and maintenance after 1,000 operation hours record into the engine log-book.

9. PARTIAL INSPECTION

This inspection is prescribed for engines constantly operated with minerals (nonadditives) oils (for example MS20), by reaching operating period, mentioned by service bulletines. These inspections can be executed without engine disassembly from the aircraft with using the corresponding tools (see the list at the section No. 7). By partial inspection, it is necessary to disassembly following engine sections:

- dynamo drive;
- air tank;
- wire ramp;
- oil and injection pipe;
- injection pump and camcase;
- suction and exhaust pipe;
- cowlings;
- cylinder head;
- cylinders and pistons;
- supercharger;

A. Engine Disassembly

Execute the disassembly according to process, mentioned in section 7 of this manual.

B. Inspections, Adaption And Repairs Of Parts

Valves:

Execute the decarbonisation and all valves inspection according process mentioned in section 7 of this manual (chapter 18, para i/, point 7).

Cylinder Heads:

Execute decarbonisation of compression chambers. By decarbonisation take care not damage and release the copper sealings. Released and damaged sealings replace with new ones. Execute the valve saddle inspection in cylinder head acc. process mentioned in section 7 of this manual.

Pistons:

Take off pistons rings and execute decarbonization of whole piston /except graphited coating/, especially the front part and piston rings groove.

Attention: *By decarbonization it is necessary to clean grooves very carefully and clean openings by scraper rings for the reason of good oil passage.*

After decarbonization and cleaning, check the piston, if there are not traces of seizing or cracks.

Polish piston pin rods.

Check the piston rings acc. to process mentioned in section 7 of this manual (chapter 18, para1).

Valve Springs:

Execute visual inspection for cracks.

Cylinders:

Execute decarbonisation in the upper part of cylinder. Fine abrasions or grooves on cylinder polish with soft emery cloth soaked in kerosene.

Camcases:

Clean camcase and take-off oil sediment, execute distribution system inspection, if there are not traces of wear (camshaft, balance beams, regulation screws). Take-off the oil cleaner from distribution case and purify well.

Ignition:

Inspect and care magnetos in volume prescribed by 50-hours inspection. Execute care of ignition plugs acc. To section 7 of this manual (chapter 10). Shielded covering on wires to plugs should not be damaged. Replace wire with damaged shielded isolation. Check insulators and wire ends, if they are not broken, burnt or pierced. Replace damaged wires and insulators.

Suction and Exhaust

Inspect suction pipe for cracks, on suction elbows inspect the thread for injection nozzles, if it is not damaged. Replace rubber sleeves on suction pipe, if there are cracks. Execute decarburization on exhaust pipe.

Injection Pump

Inspect and care injection pump in volume prescribed for 50-hours inspection. From fuel chamber discharge fuel to clean, dry, glass vessel and wash-out the chamber. Discharged fuel check for water abundance.

Connecting Rod:

Connecting rod projecting parts from engine case clean carefully with full soaked rog and dry up. Check the opening for piston pin in connecting rod and piston pin surface for carbonization. The right condition is clean metallic, smooth without carbonization or seizing marks. If we find seizing marks in opening of connecting rod small end of piston pin - it is necessary to replace the connecting rod. Seizing marks, it means:

- 1/ Places, where is putted on the material of connecting rod on the piston pin;
- 2/ Glinding part of connecting rod little end for piston pin large damages by some impurity, for example by hard carbon, which is not possible to remove by lapping, in volume of max. opening clearance of connecting rod little en and piston pin 0.04mm. Opening lapping executes in the best way by cast iron pin and diluted oil for exact cylinder shape. Lapping execute after crack detection.

Connecting rod opening in the perpendicular plane to connecting rod longitudinal axis, can be rarely hued by deposit, but not measurable thickness and the metal of connecting rod is intransparent view, without seizing traces. If found carbonization in connecting rod eye in longitudinal direction or on piston pin surface, it is not right condition, which has been written to the inspection report. Carbonization at these places is caused mostly by used oil insufficiency. Increased carbonization could be caused by operation conditions over limit, mostly temperature, not suitable fuel, irregular spark advance and engine power overlimiting.

After carbonization located close to the piston pin find, execute decarbonization of connecting rod parts projected from the engine case. Rinse with fuel, dry up and immerse into the decarbonization liquid.

"DECARBON T" use in the best way in the tank hanged under the engine case between screws for cylinders and immerse the connecting rods to the liquid above openings for piston pins. "DECARBON T" has following content:

- Carbon oil (incl. 25% of phenol)	100 ml
- Trichlorethylene	250 ml
- Petrol sulphonate	20 - 40 ml
- Tricresol	20 - 40 ml
- Pasty soap	90 - 100 g
- Water glass	0,5 - 1 ml
- Water	10 - 25 ml

By usual temperature about 20°C, latest after 24 hours deposited carbon will be dissolved. Then execute carefully inspection of connecting rod eye opening. The inspection execute by crack detector especially in the place, where piston pin by pressure at the piston lies in the connecting rod eye.

Execute measuring of connecting rod eye and piston pin. By comparison check the clearance, which has to be between 0.015 and 0.030mm.

Measuring execute by temperature of about 20±5°C. The best clearance is 0.020mm. Values and adjustments have to written to the engine inspection report. If even little crack was found in the connection rod eye, it is necessary to replace the connecting rod.

Supercharger:

Execute the supercharger inspection acc. The process described at section 7 of this manual (chapter 13, 14) (is valid for M332A/AK and M337A/AK).

Engine Assembly

Execute engine assembly acc. the process described at section 7 of this manual.

10. NON-SCHEDULED INSPECTIONS

The engine manufacturer can decide upon the opportunity of other kinds of inspections. The volume and applicability of these inspections are communicated to operators by means of bulletins. These bulletins are mandatory for engine's owners. When performing Non-Scheduled Inspections, required during engine operation time, apply technical procedures as indicated in SECTION 7 of this manual.

11. OPERATING LIMITS TILL OVERHAULS, SERVIS LIFE, NUMBER OF OVERHAULS

Operating limit to overhaul:

1. Operating date to overhaul expressed in operating hours of engine is appointed from appropriate service bulletins (or from "Charge to maintenance air capability").
Further-operating limit to overhauls depends on production date of the engine, on character of use (acrobatic, nonacrobatic), on kind of used oil - see in detail in service bulletins.
- 2 To reach prescribed operational limit, it is dependable on executing regular engine inspections, their volume is mentioned in documentation, by implementation of actual service bulletins and by application of original spares. Used spares must have a-test about release JAA FORM ONE by LOM PRAHA s.p. or by him accredited deliverer.

WARNING: FOLLOW THE LATEST REVISIONS OF SERVICE BULLETINS ISSUED BY LOM PRAHA s.p. FOR GETTING ACTUAL INFORMATION AND ADVICES FROM AREA OF OVERHAULS.

Service life limit of engine and number of overhauls:

Service life of engine is not limited

Number of overhauls is not limited.

Page without text

SECTION 7

MAINTENANCE PROCEDURES

1/ Oil Renew Procedure	7-2
2/ Cylinder Compression Check Procedure	7-5
3/ Cylinder Head Studs Torque Check Procedure	7-6
4/ Valve Clearance Check Procedure	7-6
5/ Magneto Replacing Procedure	7-9
6/ Magneto Adjust and Maintenance Procedure	7-12
7/ 500-Hour Magneto Inspection Procedure	7-12
8/ Magneto Timing Procedure	7-13
9/ Starting Vibrator Maintenance and Check Procedure	7-13
10/ Spark Plug Maintenance Procedure	7-14
11/ Generator Maintenance Procedure	7-15
12/ Supercharger Clutch Adjustment Check Procedure	7-16
13/ Supercharger Condition Check Procedure	7-17
14/ Starter Maintenance Procedure	7-18
15/ Oil Pressure Adjustment Procedure	7-22
16/ Fuel Strainer Check Procedure	7-23
17/ Fuel Pressure Adjustment Procedure	7-24
18/ Piston-Cylinder Group Part Replacing Procedure	7-25
19/ Assembly Tools	7-35
20/ Special Tools and Fixtures	7-36

OPERATOR'S MANUAL

Note: For easier orientation while performing works in compliance with the below mentioned procedures, it is recommendable to refer to the SPARE PARTS CATALOGUE. Every work beyond the volume of the 10- and 50-Hour Inspection may only be carried on by a mechanic from engine's manufacturer or trained and certified by approved organization.

1. OIL RENEW PROCEDURE

- a/ Before renewing oil, warm up engine to normal operation temperature.
 - b/ Drain oil from the oil tank.
 - c/ Remove and clean oil strainer from the oil tank according to airframe manufacturer's prescriptions.
 - d/ Remove drain plug-oil screen from the camshaft drive housing at Models M 132A, M 332A and M 337A. At Models M 137A/AZ, M 337AK, M 332AK and M 132AK remove plug from the camshaft drive housing, gravity valve included.
- Attention:** Avoid possible fall to earth of the gravity valve after removing the drain plug.
- e/ Remove drain plug from the injection pump and meanwhile the filling plug on the lateral side of the injection pump (to facilitate oil draining).
 - f/ Remove plug and check injection pump correction compartment for evidence of oil. If positive, drain oil and reinstall plug.
 - g/ Remove lid from the oil inlet strainer of the oil pump, extract oil screens and disassemble. (it consists of 3 oil screens.)
 - h/ Remove oil strainer from oil sump.
 - i/ Remove oil strainer from crankcase top lid.

Note: The checking and the cleaning of the oil strainer in the crankcase top lid are only to be performed during the 500-Hour Inspection.

j/ Check all oil strainers and screens for evidence of metallic particles. Then rinse them in technical gasoline and reassemble them, wire securing included.

Attention: Evidence of metal particles indicates excessive wear of some engine parts and hence the necessity of engine inspection by a mechanic from engine's manufacturer or trained and certified by approved organization.

k/ Screw on injection pump drain plug and secure with wire. Fill pump with engine oil till the top of the filling orifice. Screw on filling plug.

Attention: Drain oil from engine into a clean vessel to make possible evidence of metallic particles. Meanwhile avoid oil depreciation for the case of further use-such as strainer maintenance and check before oil change period is over. For oil change period see SECTION 4.

l/ Fill oil tank with oil in accordance to the specification in SECTION 4 of this manual.

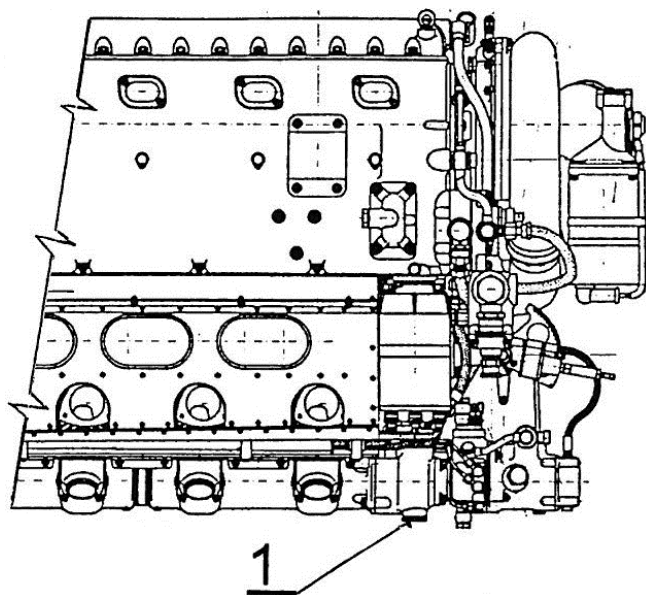

1- Drain Plug-Oil Strainer In Camshaft Drive Gear Housing
Fig. 7-1 a

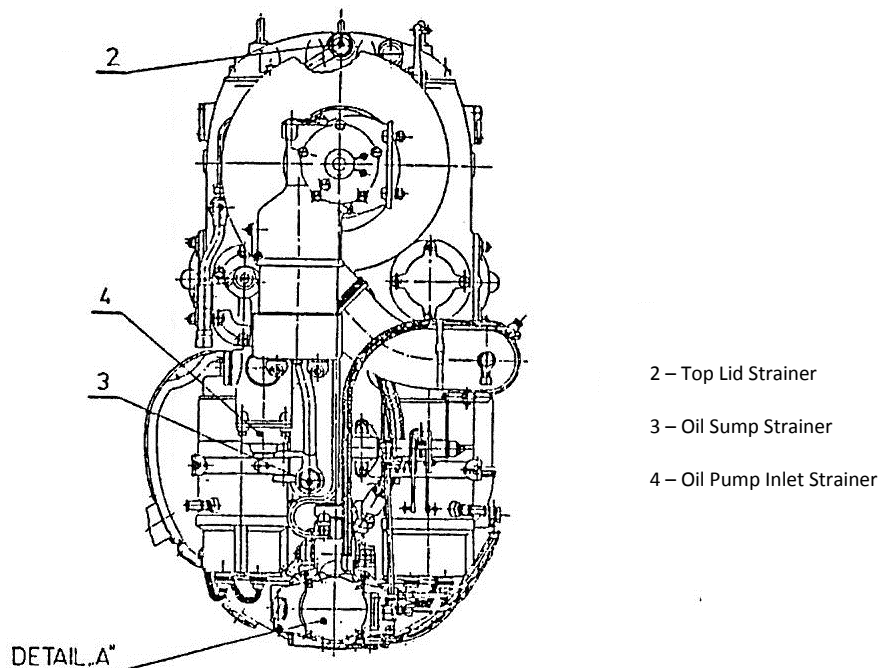

- 2 – Top Lid Strainer
- 3 – Oil Sump Strainer
- 4 – Oil Pump Inlet Strainer

Obr. 7-1 b

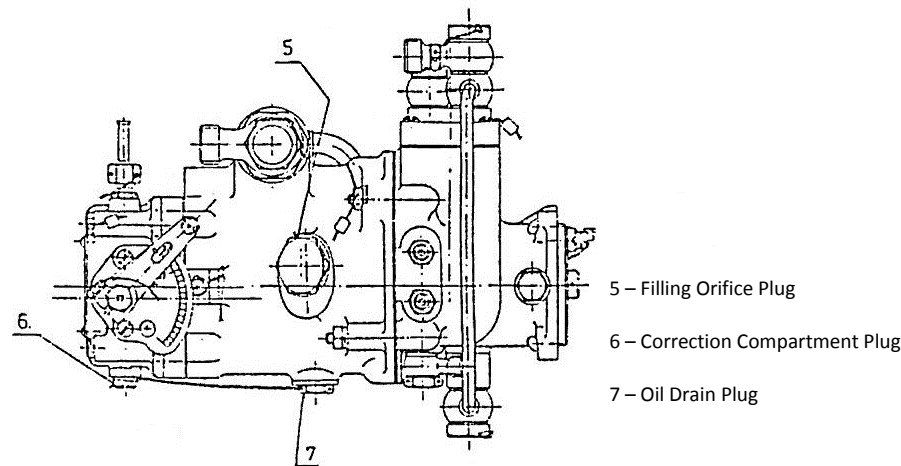

- 5 – Filling Orifice Plug
- 6 – Correction Compartment Plug
- 7 – Oil Drain Plug

Obr. 7-1 Detail „A“

2. CYLINDER COMPRESSION CHECK PROCEDURE

Attention: Perform compression check when cylinder head temperature is 50 ÷ 70 °C (122 ÷ 158°F) and battery fully charged.

- a/ Set magneto switch selector in “OFF” position.
- b/ Set fully opened throttle.
- c/ Remove spark plugs on the right side.
- d/ Apply pressure gage on spark plug orifice from cylinder no. 1
- e/ Crank engine by means of the starter.
- f/ Read and record measured pressure value.
- g/ Repeat procedure for all cylinders.

Note: For compression measurements it may be used special instruments equipped with pressure registration from each cylinder. When applying, observe instrument manufacturer’s instructions.

- h/ Compression check results evaluation:
The evaluation of the results depends in considerable degree upon the experience of the maintenance personnel. As still acceptable minimum value consider 490 kPa (71.1 lbs./sq.in). Beside absolute compression pressure value it is also very important the magnitude of pressure differences in between cylinders. In case of striking pressure difference of one cylinder in relation to the others, one can conclude that there is increased wear of the mobile parts from that cylinder and hence the necessity to pay greater attention to the incriminated cylinder in the next operation period.

Note: In case of doubt of proper compression, it is necessary to entrust all works concerning determination of trouble and consequent repair to a mechanic from engine’s manufacturer or trained and certified by approved organization.

3. CYLINDER HEAD STUDS TORQUE CHECK

Attention: Perform cylinder head studs torque check when engine is cold.

- a/ Remove all engines cowl to facilitate access to all cylinders.
- b/ Remove seven protection covers on the lower side of the air scoop. (At engines without protection covers, remove the whole lower side of the air scoop.)
- c/ Select 24,5 Nm (18.1 ft.lbs.) torque at torque wrench with prolonger.
- d/ Torque cylinder heads nuts to the selected value in the order indicated in Fig. 7-2.
- e/ Reassemble protection covers (or the lower air scoop side). Shut engine cowls.
- f/ Shut engine cowls.

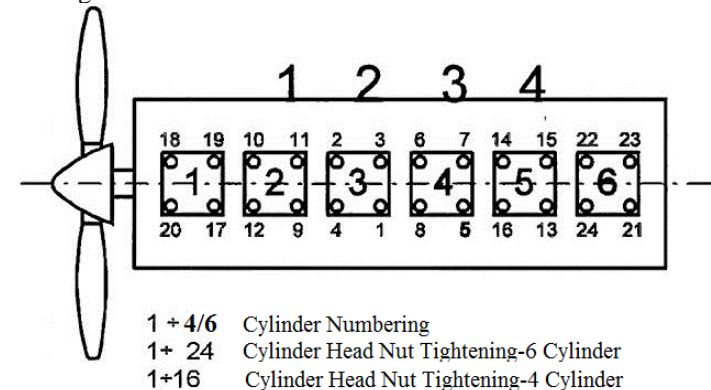

Fig. 7-2

4. VALVE CLEARANCE CHECK PROCEDURE

Note: Perform valve clearance check when engine is cold and outside temperature min. 10°C (50°F), after balance of outside and engine temperature.

- a/ Set magneto switch selector in “OFF” position.
- b/ Remove engine cowls.

- c/ Remove drain plug from the camshaft drive gear housing and drain oil from camshaft into clean vessel. Keep away oil from dirt.
- d/ Remove plugs from the access holes in the camshaft housing by means of the special wrench from the service board tools.
- e/ Remove spark plugs from the right side of engine.
- f/ Standing "en face", turn the engine in the clockwise in such way, that the valves of the adjusted cylinder will be closed.
- g/ Clean the bearing surface for the plugs.

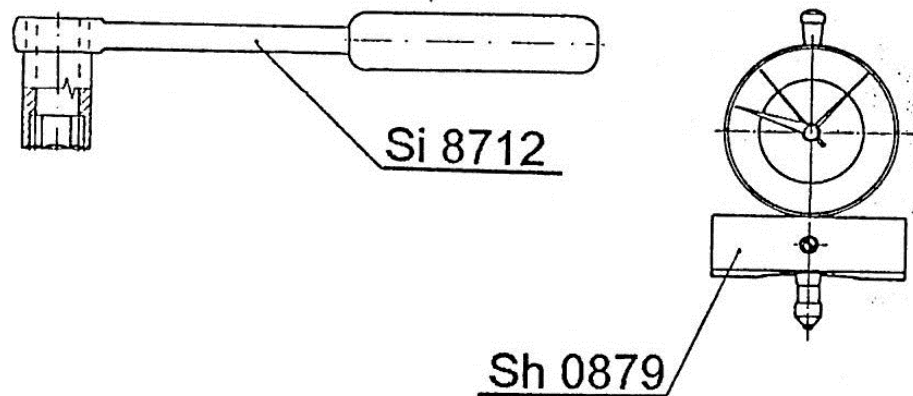

Fig.7-3

- h/ Use:
 - Si 8712 (Valve clearance adjustment spanner) –picture 7-3;
 - Sh 0879 (Valve clearance gauge) – picture 7-3;
 - narrow screwdriver.
 - i/ Apply the valve clearance gauge to the plug bearing surface of the controlled valve cam box in such way that the indicator tip will bear on the valve clearance adjust screw (see fig. 2-1b, pos. 12.)
 - j/ Apply the screwdriver round the taking-out in measuring prism and move the rocker arm. Then you can read the valve clearance.
 - k/ In case, you read the valve clearance different from the prescribed one, you must adjust it.

Prescribed clearances:	- intake valve	0,25 mm (0.0098 in.);
	- exhaust valve	0,40 mm (0.0157 in.).
 - l/ Apply the wrench Si 8712 on the contra-nut and turn it on the left one half of thread. Keep the wrench being on the contra-nut. To the wrench hollow put the screwdriver, apply it to the slot of valve clearance adjust screw. Turn the valve clearance adjust screw to the position you need and retighten the contra-nut immediately. During this retighting still keep the valve clearance adjust screw in the position you need. Retightening of contra-nut safes the position of valve clearance adjust screw.
- Note: The lead of valve clearance adjust screw is 1mm. by turning 0.1 revolution left the valve clearance will grow large 0.1 mm and on the contrary.*
- m/ Check the valve clearance again, and if is necessary, repeat adjustment.
 - n/ Go on with checking and adjusting of valve clearance on the others cylinders.
 - o/ After the valve clearance checking and adjusting of all cylinders, install the cam-box plugs back. During this procedure, check the "O" rings and change them in case of need
 - p/ If the discharged oil is not worn-out (point b/), you can still use it. But only in case, if the valve clearance check procedure does not fall at same time like the interval of changing oil in engine installation.

5. MAGNETO REPLACING PROCEDURE

If magneto failure occurs during operation, replace it in compliance with the next procedure.

a/ Remove engine parts and accessories, which hinder to remove magneto. At the right magneto:

- disconnect the fuel priming hose and the fastening strip of the correction hose;
- dismount manifold section between supercharger and straight manifold section;
- disconnect throttle lever rod.

At the left magneto:

- disconnect cooling air hose

b/ Disconnect short-circuit lead from magneto short-circuit lead socket, remove plug from magneto adjust screw window. This window is located on the left side of the crankcase for the left magneto and on the rear side for the right magneto. Unfasten magneto belt screw and strongly tighten magneto adjust screws through crankcase windows. Magnetos may not rotate during this operation. Then screw off fastening belt screw, open belt, unscrews the two screws fixing shielding covers and distributor block protection. Extract shielding cover with harness and distributor block protection. Unscrew the two screws from the distributor block and extract them.

c/ Remove spark plugs from the intake side of the engine. Rotate crankshaft till the piston in the first cylinder reaches TDC on the compression stroke (both valves are shut). Then rotate propeller in the opposite direction of normal rotation for about 30 ÷ 40°, insert 0.03 mm (0.0012 inches) feeler between breaker points and then slowly rotate in normal crankshaft rotation (the best by bumping against propeller blades) until breaker points liberate the feeler to the point it can be easily extract. Leave propeller in this position, which one can mark on spinner and engine cowl.

d/ Unscrew the nuts retaining the drive adapter, remove washers and extract magneto from crankcase.

e/ Before assembling the new magneto, position it in such a manner that, while the short-circuit lead socket is perpendicular to the engine axle, the magneto drive adapter be directed toward the hole in the crankcase hole,

through which the adjust screw is tightened, after the magneto is mounted onto the engine. In this position of the drive adapter, tighten the adjust screw and then remove the shielding cover and distributor block together with its protection.

Fig. 7-4

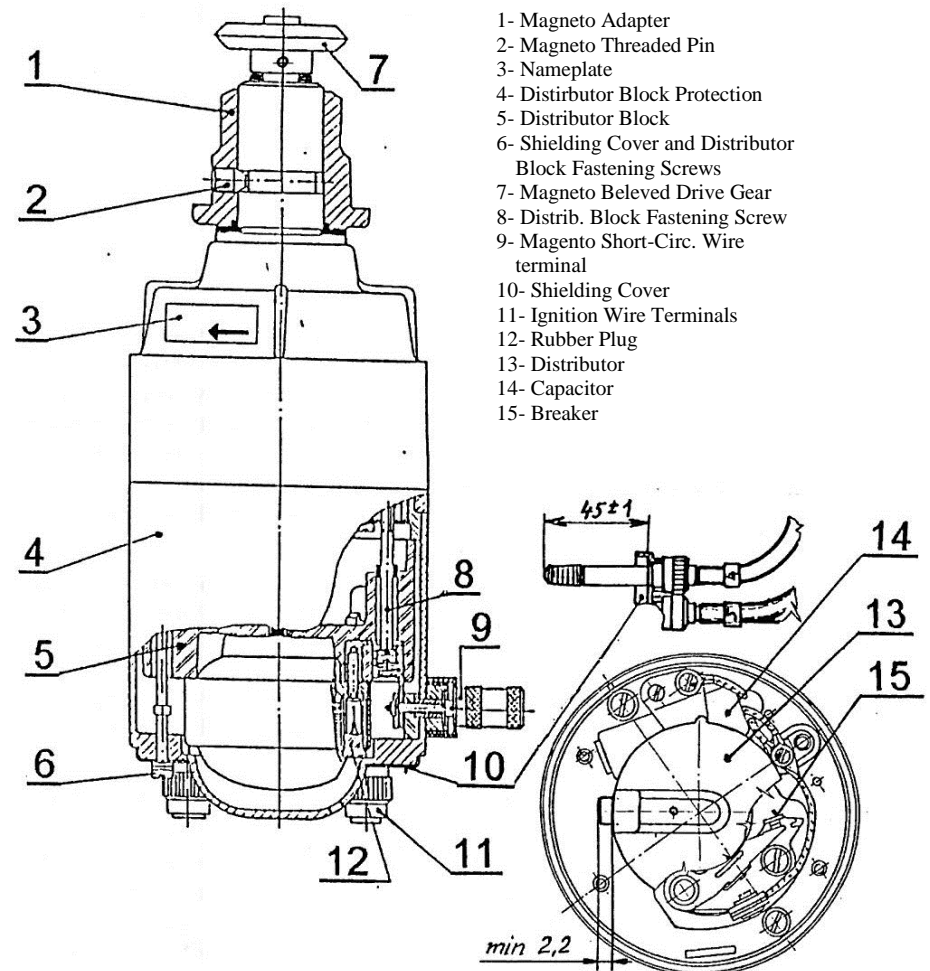

- 1- Magneto Adapter
- 2- Magneto Threaded Pin
- 3- Nameplate
- 4- Distributor Block Protection
- 5- Distributor Block
- 6- Shielding Cover and Distributor Block Fastening Screws
- 7- Magneto Beveled Drive Gear
- 8- Distrib. Block Fastening Screw
- 9- Magneto Short-Circ. Wire terminal
- 10- Shielding Cover
- 11- Ignition Wire Terminals
- 12- Rubber Plug
- 13- Distributor
- 14- Capacitor
- 15- Breaker

- f/ Rotate distributor with its arm pointing to the notch on magneto housing, i.e. in the position, when spark occurs at the first cylinder. Hold distributor in this position. Place gasket on the drive adapter, install magneto to crankcase and fix it by means of the two nuts with washers. The propeller must be in the same position, as when the magneto had been dismantled. If the teeth of the gear wheels don't match, when installing magneto, facilitate matching by extremely small movements of the distributor.
- g/ Insert 0.03 mm (0.0012 in.) feeler between breaker points. If it cannot be easily taken out, or it is free between points, loose the adjust screw through the crankcase hole, rotate magneto in a convenient manner, so that the feeler can be easily taken out. Tighten the adjust screw in this position. The magneto timing is the same as the removed magneto timing. If performing these steps, the short-circuit lead socket would come up to an improper position, it is necessary to reset the magneto gear by one tooth, until the socket comes up to the position perpendicular to the engine axle. Time magneto again after this.
- h/ Consequently to magneto timing and adjust screw tightening, fasten the distributor block and reinstall its protection, assemble the original shielding cover with the connection leads from the removed magneto (to avoid leads to be reconnected to the new shielding cover). Install shielding cover with mark 1 in alignment with the same mark on the distributor block and fasten it on magneto. Reinstall plug in crankcase window. Fasten the fixing belt around magneto. Connect the short-circuit lead to the socket. Reinstall spark plugs, connect ignition terminals.
- i/ Perform engine test in compliance with instructions in SECTION 5. At the RPM drop check, when selecting each magneto, it must be obtained the prescribed RPM drop value 30 ÷ 50 RPM when only one magneto operating. If this condition will be not fulfilled by the newly installed magneto, perform magneto timing according to the procedure in this section.

6. MAGNETO ADJUST AND MAINTENANCE PROCEDURE

This procedure has to be performed after the first 50 hours operation time and then after every 100 hour of operation. Service magnetos with removed distributor block.

- a/ Check breaker points for condition. Clean and straighten contact surfaces if necessary. Gap breaker and regap if necessary to prescribed value: 0.25 ÷ 0.35 mm (0.0098 ÷ 0.0138 in.)
- b/ Check acting surface of cam and lubricating felt for condition. Clean cam surface if necessary. Impregnate felt with oil in compliance with SECTION 4. Breaker points should remain free of oil.
- c/ Inspect distributor. Clean distributor, electrode included. If evidence of cracks or spark discharges on its surface, replace it.
- d/ Clean distributor block surface. If evidence of cracks or other damage, replace it. When reinstalling it, pay attention to correct positioning and toughly tighten screws. Check plastic plug sealing; if high tension outlet sealing is defective, replace it. When assembling the shielding cover to the distributor block, conductive contact must be established between terminals and electrodes. Check and possibly adjust distance between distributor block bottom and ignition leads terminals to 45±1 mm (1.771±0.039 in.).
- e/ Clean ignition harness supporting tube, shielded ignition wires, shielded elbows and ignition leads terminals connected to spark plugs.

7. 500-HOUR MAGNETO INSPECTION PROCEDURE

- a/ Check distributor electrode for condition. Electrode dimension must be min. 2.2mm (0.087 in.) see fig. 7-4. If wear is greater, then distributor replace.
- b/ Check breaker points for condition. Replace capacitor, if excessive pitting or blackened. If not possible to straighten points and remove pitting caused by discharges, then replace breaker.
- c/ Check excentric regulator for condition:

- 1/ Rotating propeller, leave cam in position with breaker contact shut. Hand rotate distributor arm in magneto rotation direction until stop. Distributor arm should return automatically, after being released. If not returning or only partially, this proves defective distributor and hence the necessity to replace it.
- 2/ While engine is running with both magnetos operating, slowly increase RPM from idling and watch if engine experiences abrupt RPM increase between 1000 and 1500 RPM. Then slowly decrease from 1000 to 1500 RPM and watch again if abrupt RPM drop is experienced. If abrupt RPM variations are noticed and no engine failure can be detected as a cause, this means that the centrifugal regulator of one or both magnetos is defective and hence the necessity to replace defective magnetos.

8. MAGNETO TIMING PROCEDURE

Basic ignition advance is 7° BTC. This advance has still to be adjusted during engine running, so that the RPM drop at maximum continuous power rating, while selecting one magneto operation, do not exceed 30 ÷ 50 RPM. If RPM drop is greater than mentioned value, time magnetos in compliance with the following procedure.

If RPM drop is greater than 50, increase advance. If RPM drop is smaller than 30, decrease advance. Before timing magneto, loose fixing belt, remove crankcase window plug for access to the adjust screws and partially loose these screws. Ignition advance change occurs by rotating magnetos. To decrease advance, rotate in the direction of magneto rotation. To increase advance, rotate in the opposite direction of magneto rotation. The sense of rotation is indicated by an arrow on magneto nameplate.

9. STARTING VIBRATOR MAINTENANCE AND CHECK PROCEDURE

Note: The starting vibrator is located on the firewall at the Z-142 aircraft.

- a/ Remove the two brackets fixing the vibrator cover.

- b/ Remove cover.
- c/ Clean burnt breaker points by means of a fine file.
- d/ Check vibrator for operation and adjust:
Adjust vibrator by bending the plane spring, on which there are located the small anchor and the breaker mobile contact. Under a nominal 24 V voltage, the current through breaker contact must be 1 A. During adjusting operation, don't keep closed contact for more than 20 sec.

Attention: Set magneto selector switch in "OFF" position.

- e/ Reinstall vibrator cover and secure by means of the brackets.

10. SPARK PLUG MAINTENANCE PROCEDURE

- a/ Open engine cowls.
- b/ Remove securing and extract air scoop access window cover sheet to create access to the left spark plug row.
- c/ Unscrew ignition harness terminals from spark plugs.
- d/ Remove all spark plugs, including gaskets, by means of the spark plug wrench from the engine tool set.

Note: On the 3rd cylinder of 4-cylinder engines and on the 4th cylinder of 6-cylinder engines, on the right side, instead of normal gasket, there is a thermocouple type spark plug gasket. (Applicable for engines powering ZLIN type aircrafts).

- e/ Remove carbon deposits from electrodes for e.g. by sand-blasting.

Attention: A too long sand-blasting can result in excessive electrodes wear.

- f/ Check electrodes gap: 0.4÷0.5 mm (0.0157÷0.0197 in.)
- g/ Check spark plug and thread surface for condition.

Attention: The thread may not be damaged or out of shape.

- h/ After sand-blasting, clean spark plug by blasting it with compressed air.
- i/ Wash spark plug in technical gasoline and dry it in compressed air jet.

- j/ Test spark plug on test bench for proper operation if such an installation is available.
- k/ Replace damaged or defective spark plugs.
- l/ Place gaskets on spark plugs and apply a light coating of graphite grease to the threads.

Attention: *Reject too much worn or deformed gaskets and replace with new ones.*

- m/ Screw on spark plugs and gaskets, in the first phase by hand till one makes sure, that the spark plug has properly engaged the cylinder head hole. Than continue to tighten by means of the spark plug wrench.

Note: *Check cylinder head holes for evidence of eventual damage or if the threaded inserts are not damaged or loose.*

- n/ Screw on and tighten ignition harness terminals to spark plugs.

Attention: *Verify terminals if complete. Tighten spark plug with care to avoid damage of the terminal insulator.*

- o/ Install air scoop access windows cover sheet and secure.
- p/ Shut engine cowls.

11. GENERATOR MAINTENANCE PROCEDURE

- a/ Disconnect generator connection leads.
- b/ Remove generator from engine:
 - loose generator fixing belt,
 - remove generator flange nuts
- c/ Remove carbon brush case protection pads.
- d/ Depress carbon brush springs and extract them.
- e/ Check carbon brush wires for condition and electrical continuity.
- f/ Check carbon brush for wear-minimum length is 12 mm (0.4724 in.). Replace carbon brushes if greater wear is evidenced.

- g/ Clean collector case by means of compressed air jet.

Attention: *If collector surface damage is evidenced, it is necessary to be checked and possibly repaired. These operations may be performed by a mechanic from engine's manufacturer or trained and certified by approved organization.*

- h/ Reassemble generator in opposite order than at disassemble.
- i/ Check all generator fixing points for completion and proper tightening.

12. SUPERCHARGER CLUTCH ADJUSTMENT CHECK PROCEDURE

Supercharger engaging clutch consists of a belt brake and hence the necessity of proper adjustment to avoid skidding when engaged.

- a/ Open engine cowls.
- b/ Remove wire securing clip from adjust screw pos. 1. See Fig. 7-5.

Fig. 7-5

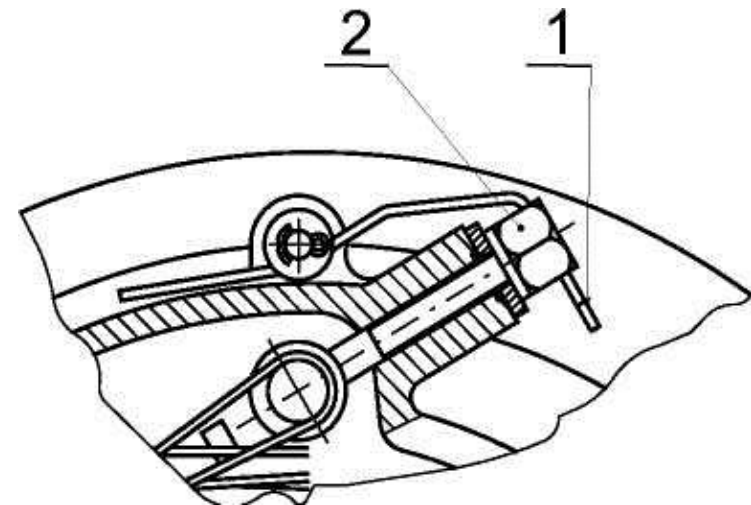

- c/ By means of a screwdriver, turn adjust screw pos. 2 to the right to tension the belt brake.
- d/ Reinstall wire securing clip in its original position.
- e/ Shut engine cowls.
- f/ Supercharger clutch adjustment test:
 - in "SUPERCHARGER ENGAGED" position, the propeller may not slow or stop during engine starting.
 - in "SUPERCHARGER DISENGAGED" position, the manifold pressure may not exceed 100 kPa (28.94±0.59 in.Hg).

13. SUPERCHARGER CONDITION CHECK PROCEDURE

- a/ Loose the 4 nuts and disconnect supercharger air inlet duct from air strainer.
- b/ Remove fuel priming line from the air manifold.
- c/ Loose fastening nuts from both ends of the engine air manifold front section and disconnect the supercharger output air duct. Use special wrench from the Service Board Tools.
- d/ Disconnect starter conductors.
- e/ Disconnect supercharger control rod.
- f/ Disconnect supercharger lubricating oil pressure line.
- g/ Unscrew supercharger flange fixing nuts and extract supercharger from engine.
- h/ Remove entire starter from supercharger.

Note: While dismantling the starter, avoid to damage the starter case gasket. If necessary to replace, use gasket of the same thickness. Service starter according to the procedure in this section.

- i/ Remove securing and loose the front bolts of the silentblocks and extract the front support of the elastic coupling.

- j/ Remove securing and unscrew the rear bolts of the silentblocks from the rear elastic coupling support and consequently extract silentblocks.
- k/ Check silentblocks rubber for cracks and if detached from steel pad. Use fixture from the Special Tools and Fixtures set. Replace damaged silentblocks by new ones.
- l/ Check frontal dented gear for condition. Dent frontal areas must be straight and parallel with the gear axle. The edge chamfer must be within the prescribed limits: 0.5 ÷ 0.7 mm (0.0196 ÷ 0.0275 in.).
- m/ Check supercharger bearing for axial clearance:
Lean dial indicator feeler point against the supercharger impeller shaft in the directions. Max. admissible clearance is 0.25 mm (0.0098in.). If greater values are registered, replace bearing.
- n/ Clean supercharger air inlet spiral.
- o/ Mount back supercharger in the opposite order as dismantled.

Note: Pay attention to proper tightening and securing during reassemble.

14. STARTER MAINTENANCE PROCEDURE

- a/ Dismount starter from flange. See Fig. 7-6a or 7-6b.

Note: While dismantling the starter, avoid to damage the starter case gasket. If necessary to replace, use gasket of the same thickness.

- b/ Check engaging frontal dented pos. 1 gear for condition. Dent frontal areas must be straight and parallel with the gear axle.
- c/ remove starter case lid pos. 2, electromagnet included.
- d/ Check electromagnet engaging mechanism pos. 3 for condition and freedom of operation. If damaged, replace whole starter case lid pos. 2, electromagnet included. The clearance between electromagnet engaging mechanism pos. 3 and elastic pad of the engaging gear pos. 4 must be 0.1 ÷ 0.2 mm (3.94 ÷ 7.87 in.).

- e/ Check elastic pad of the engaging gear pos. 4 for condition. If damaged, replace engaging gear pos. 1.
- f/ Grease starter case interior with grease quality according to specifications in SECTION 4, through the oil check plug hole pos. 5 in Fig. 7-6a/b. The required grease quantity is: 0.05 kg (0.11 lbs.).
- g/ Dismount electromotor pos. 6 from starter case flange pos. 7.
- h/ Check shaft sealing plug for proper operation. No traces of grease may be evidenced in the electromotor driving compartment. If grease is evidenced, replace shaft sealing plug.
- i/ Extract carbon brush protection from the lower part of the electromotor.
- j/ Check carbon brushes for wear. Minimum admissible length is 12 mm (0.472 in.). Replace worn carbon brushes.
- k/ Clean collector by means of compressed air.

Attention: *If collector surface damage is evidenced, it is necessary to be checked and possibly repaired. These operations may be performed by a mechanic from engine's manufacturer or trained and certified by approved organization.*

- l/ Check carbon brush wires for electrical continuity and proper tightening.
- m/ Mount starter in opposite order than dismantled.

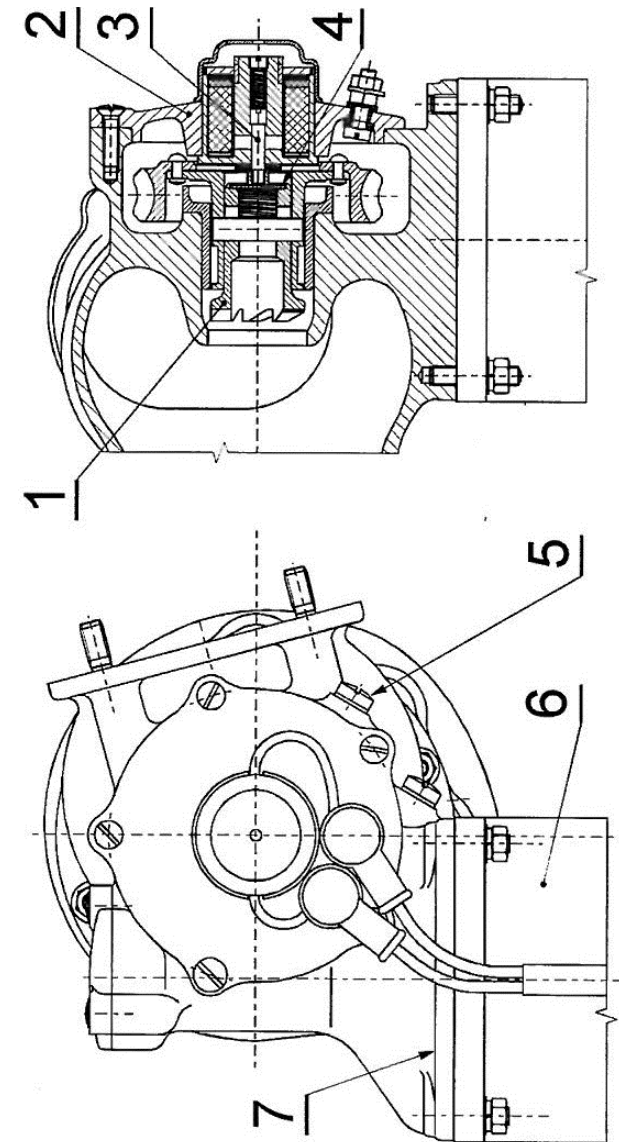

M332 and M337 Engine Starter
Fig. 7-6 a

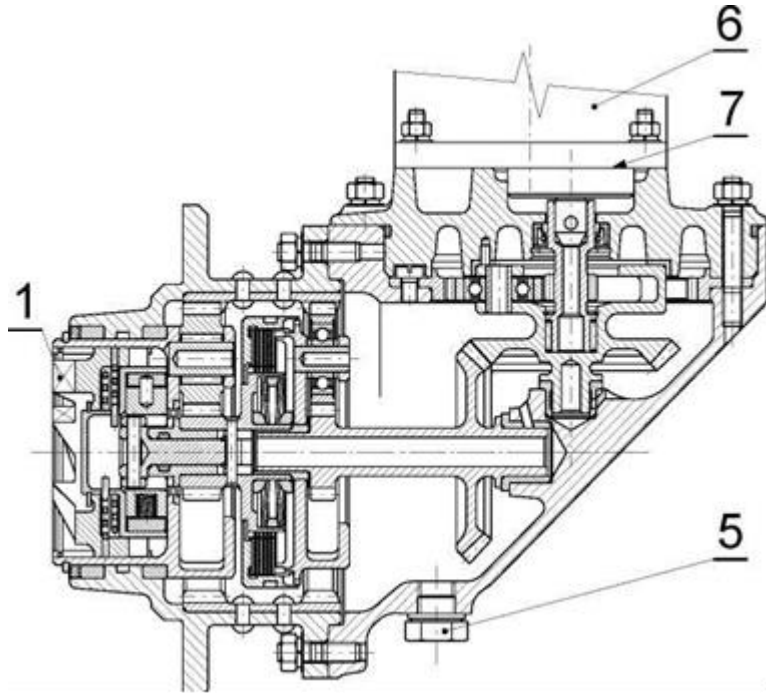

Fig. 7-6 b
M137 and M132 Engine Starter

Note: When mounting back starter on supercharger flange, reuse the original gasket or a new one, but having the same thickness, so that the final clearance between engaging gear and engaged gear (solidar with the engine crankshaft) measure 0.7 ± 0.1 mm (0.0276 ± 0.00394 in.).

Note: Works mentioned-in para c/, d/, e/, are prescribed only for starters used in engines with supercharger (family M332 and M337).

15. OIL PRESSURE ADJUSTMENT PROCEDURE

Note: The oil pressure adjustment is to be performed after engine installation or in the case that the oil pump was changed. During operation time, only oil pressure check at different engine ratings is to be performed in compliance with specifications in SECTION 3. If necessary during operation time, adjust oil pressure according to the following procedure:

a/ The adjusting screw is located on the right side of the oil pump. See fig. 7-7.

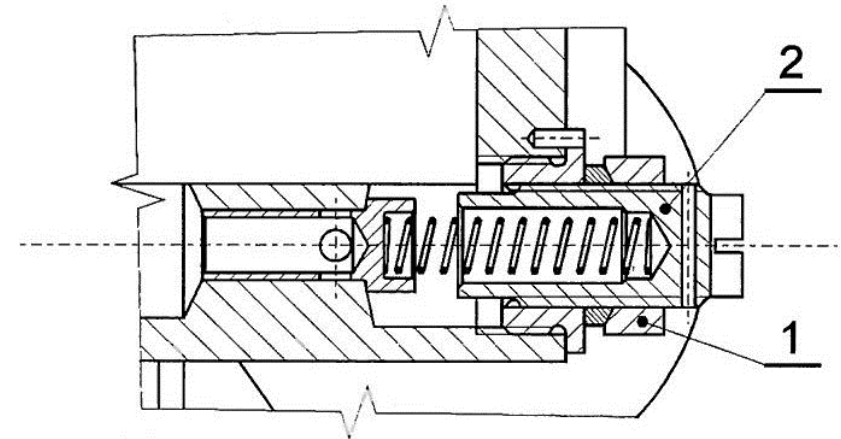

Fig. 7-7

b/ Remove securing and loose adjusting screw pos. 1.

c/ Turn the adjusting screw by means of a screwdriver:
 - to the right to increase pressure,
 - to the left to decrease pressure.

d/ Tighten screw pos. 1 to fix the adjusting screw in the selected position and secure with wire.

e/ Start engine and test proper oil pressure adjustment at rated powers in compliance with the specifications in SECTION 3 of this manual.

f/ Check connections for leaks.

16. FUEL STRAINER CHECK PROCEDURE

The fuel strainer is located at the injection pump fuel inlet, behind the fuel pressure adjusting screw. See Fig. 7-8.

- a/ Remove securing and then adjusting screw plug pos. 1.
- b/ Unscrew fitting pos. 2 from pump body.
- c/ Extract and clean inlet fuel strainers pos. 3.
- d/ Reassemble in opposite order.
- e/ Check connections for leaks.

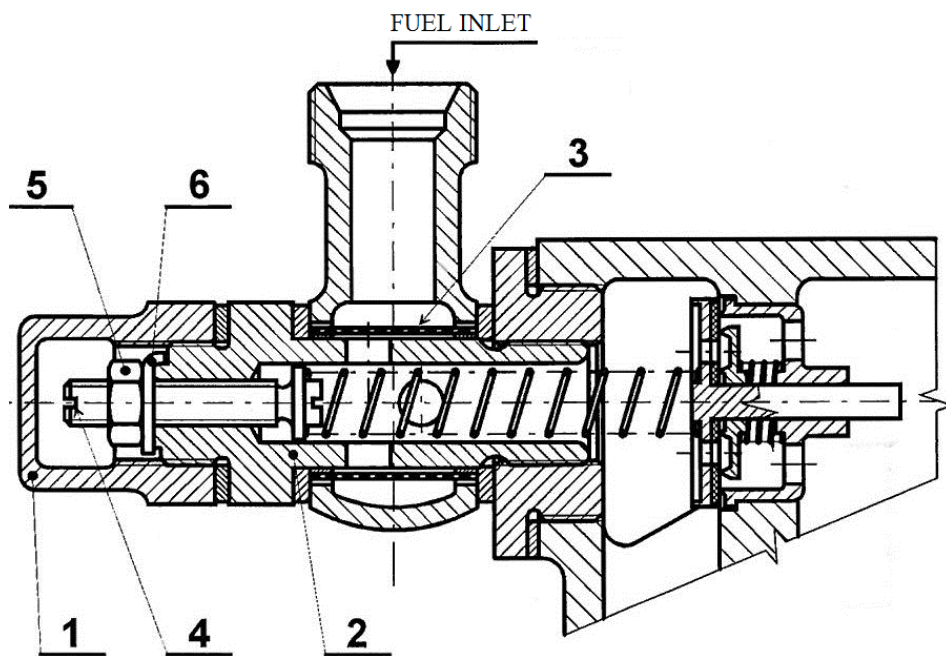

Fig. 7-8

17. FUEL PRESSURE ADJUSTMENT PROCEDURE

The fuel pressure adjustment is to be performed after the engine was installed onto the airframe and further in the case of fuel pump change.

- Note:** *The fuel pump may be replaced either by:*
- a new, engine's manufacturer adjusted pump for the pertinent engine type (the adjustment for the pertinent engine type is attested in the pump attest) or by:
 - an undamaged pump taken over from another engine of the same type and with convenient remaining lifetime until next overhaul.

Both possibilities are applicable provided that no intervention at the fuel correction adjusting valve has taken place. Enter the replacement in the pump attest.

During operation time only the fuel pressure check at indicated rated powers is performed in compliance with the specification in SECTION 3.

The adjusting screw pos. 4 for fuel pressure adjustment is located at injection pump fuel inlet, see Fig. 7-8. If necessary during operation time, adjust fuel pressure according to the next procedure.

- a/ Remove securing and fuel pressure adjusting screw plug pos. 1.
- b/ Remove securing and loose adjusting screw pos. 5.
- c/ Turn adjusting screw pos. 4 by means of screwdriver:
 - to the right to increase pressure,
 - to the left decrease pressure.
- d/ Tighten counternut pos. 4 to fix the adjusting screw in the selected position and secure by means of the securing washer pos. 6.
- e/ Reinstall plug pos. 1 and secure with wire.
- f/ Start engine and test fuel pressure adjustment at indicated rated powers according to specifications in SECTION 3 of this manual.
- g/ Check connections for leaks.

18. PISTON-CYLINDER GROUP PART REPLACING PROCEDURE

- a/ Remove engine cowls.
- b/ Dismount air scoop.
- c/ Dismount air and exhaust manifold.
- d/ Drain oil from camshaft drive gear housing.
- e/ Dismount injection pump and supercharger.
- f/ Remove spark plugs.
- g/ Remove right magneto cover, ignition wires and distributor block included to gain better access to the clamp of the connection between oil sump and auxiliary oil scavenge pump from camshaft drive gear housing.
- h/ Camcase disassemble:
 - 1/ Remove valve clearance adjust screw plugs (8 or 12 pieces).
 - 2/ Loose adjusting screw and then screw out the adjust screws till stop.
 - 3/ Loose nut fastening the scavenged oil pipe to the camcase.
 - 4/ Loose clamp of the connection between oil sump and auxiliary scavenge pump from the camshaft drive case.
 - 5/ Position the first cylinder at TDC in the beginning of the intake stroke. In this position, the color marked teeth of the central beveled gear match the color marked teeth of the vertical shaft beveled gear. (Check throughout the supercharger flange hole). There are also matching the color marked teeth of the vertical shaft and the color marked teeth of the camshaft beveled gear. (check throughout the injection pump flange hole).

Note: *For more facile identification of the color marked teeth, clean mentioned gears with gasoline. Possibly remake teeth color marking to facilitate reassemble.*

- 6/ Disassemble the guide pads of the camcase.

- 7/ Remove camcase screws excepting the exterior screws from both camcase ends.
- 8/ Loose uniformly the remaining four screws to avoid distortion of the camcase. Then while completely loosing the screws, hold the camcase and remove it from cylinder heads avoiding at the same time the distortion of the central part of the vertical shaft. This part has also to be disassembled during camcase dismounting, including the upper coupling of the vertical shaft.

Note: *While mounting back the central part of the vertical shaft, both grooved bushings have to be mounted with the shorter end toward the camcase.*

- i/ Cylinder head removal:
 - 1/ Disassemble pertaining baffles between cylinders and cylinder heads
 - 2/ Position piston in the TDC.
 - 3/ Loose and remove cylinder head nuts, washers included (4 nuts plus pertaining washers for each heads).
 - 4/ Extract cylinder head from cylinder. To facilitate separation, bumping is permitted using a plastic hammer.

Note: *The cylinder must remain on the crankcase and hence the necessity to hold it in this position while extracting the head.*

Attention: *During cylinder head extraction, do not damage the cooper gasket. Correctly extracted heads have tightly adhering gaskets. These have not to be detached or removed.*

- 5/ At each head, measure the length of the valve stem above the retaining keys, dimension A in Fig. 7-9. This dimension has to be min. 3.2 mm (0.126 in.) for both intake and exhaust valve.

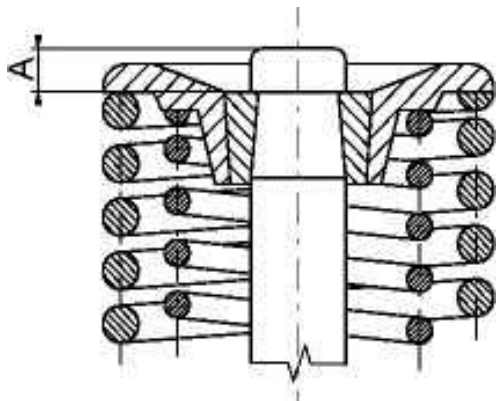

Fig. 7-9

Note: *If the keys are damaged, replace with new ones. Mark the new keys before separation and install both keys at the same valve after they were cleaned.*

- 6/ Press valve springs by means of the lever (see Special Tools and Fixtures), extract retaining keys, then free springs and extract spring seats and springs.

Note: *The keys and the valve spring seats are not interchangeable and it is necessary to be mounted back at the same valves and cylinder heads.*

- 7/ Examine valves, possibly their ground portion using the pertinent fixture (see Special Tools and Fixture). The valves with damaged or burnt edge, especially the exhaust ones, have to be rejected. Mark (cylinder number) new valves identically as the replaced valves. (See Special Tools and Fixtures for figure printers.) Prior to remount, grind valves and burnish stems and then wash them thoroughly to remove grinding compound.

- 8/ Inspect valve seats. Rework burnt valve seats using the valve seat cutter and the pertinent fixture (See Special Tools and Fixtures). Clean seat after rework and then apply grinding compound; install valve and regrind it in the seat using the grinding tool. Following this operation, extract valve and properly wash valve and cylinder head with gasoline. Check valve to valve seat setting for tightness in compliance with the next procedure: Reassemble valves and pour gasoline in the compression chamber. No leaks are permitted around valve heads for about 2 min.

- 9/ Check spark plug inserts for damaged or loosen.

- j/ Remove cylinder barrel from the crankcase, eventually applying light bumps with a plastic hammer.

Note: *Do not damage the steel gasket between cylinder barrel and crankcase. When reassembling the cylinder barrels to the crankcase, install barrels in the same position; for orientation refer to cylinder order numbers located on the centering skirt of each cylinder barrel.*

- k/ Piston disassemble:

Note: *If needed to dismount whichever piston excepting piston no. 1, it is necessary to dismount all other cylinder heads, barrels and pistons situated before it, to create space for piston pin extraction. (For example: if one needs to dismount piston no. 6, before this, he has to dismount cylinders no. 1,2,3,4 and 5 in this order).*

- l/ Remove piston pin retainers, applying the screwdriver with chamfered edge at one end only. See Fig. 7-10.

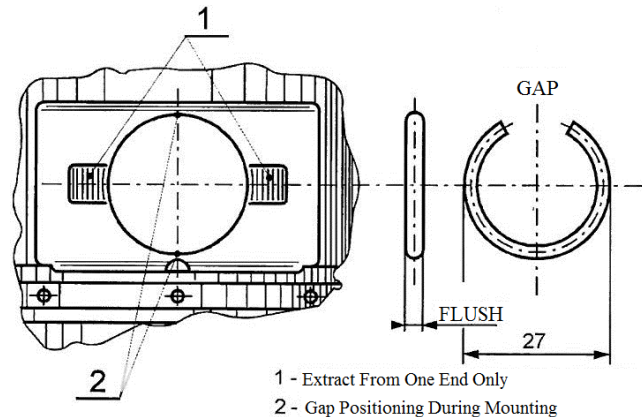

1 - Extract From One End Only
 2 - Gap Positioning During Mounting
 Fig. 7-10

Note: When forcing out the retainer, do not apply the screwdriver in more places to avoid to damage the piston. It is recommendable to insert a round wooden dowel in the piston pin hole and extract the depressed retainer.

Attention: The reuse of removed retainer is not permitted.

2/ Extract piston pin using the special extractor. See Special Tools and Fixtures.

Note: The piston pins are numbered at the end of their hole to facilitate reassemble.

- 1/ Check piston rings for condition. Replace damaged piston rings or not meeting the following requirements:
- compression rings to groove clearance:
 $0,2 \div 0,227$ mm ($0.00787 \div 0.00894$ in.)
 max. value: 0,3 mm (0.0118 in.)
 - oil regulating ring to groove clearance:
 $0,12 \div 0,16$ mm ($0.00472 \div 0.0063$ in.)
 max. value: 0,2 mm (0.00787 in.)
 - ring gap clearance:
 max. 1,2 mm (0.0472 in.)

Note: The clearance of the rings to the grooves is measured with the feeler gage and it has to be the same along the whole circumference. The gap clearance is to be measured after installing the ring in the calibrated fixture or directly in cylinder. During measuring, the ring plane must be perpendicular to the cylinder axle.

Attention: Mark or place the removed rings in such manner to make possibly an eventual reassemble in the same place. (i .e. at the same piston, in the same groove and in the same position).

For reassemble after piston-cylinder group part replacement, proceed in the opposite order of disassemble, observing all notes concerning reciprocal matching of parts and in compliance with the following procedure:

m/ Insert retainer in the rear piston pin hole end. Perform according to the prescribed procedure and using the dowel meant for this purpose. See Special Tools and Fixtures.

Note: Check retainer before mounting for dimensional accuracy. The retainer must have 27 mm (1.0629 in.) diameter in free condition, must be plane and may not be reconditioned in any circumstance. Reject part not meeting these requirements. The retainer is properly mounted if the gap is situated in the cylinder axle. (See Fig. 7-10). The retainer may be used only once. Removed retainers must be rejected.

Piston pin retainer to piston assemble procedure:

- 1/ Install piston in the fixture, see Special Tools.
- 2/ Insert retainer in the bushing and move it to the lower end of the bushing by means of the elastic dowel.
- 3/ Introduce the bushing in the piston pin hole till to the retainer groove edge, than introduce the rigid dowel and push the retainer into the groove.
- 4/ Verify the proper positioning of the retainer in the groove by means of the screwdriver with chamfered edge. No movement is permitted.

n/ Install oil regulating and compression rings in the piston.

o/ Piston to connection rod assemble:

Note: *Assemble firstly the cylinder with the greatest ordinal number, whose connecting rod was moved to the TDC.*

- 1/ Lubricate piston pin with oil and install it to the connecting rod.
- 2/ Introduce piston pin in the connecting rod bore using the dowel and then assemble the second retainer according to steps b/, c/, d/ from the piston pin to piston assemble procedure.

p/ Cylinder to crankcase assemble:

- 1/ Set gasket at cylinder bottom and lubricate cylinder barrel inside walls with oil.
- 2/ Lubricate piston and piston ring with oil, then install rings in the original position according to marks. Press piston rings by means of the ring compressor, see Special Tools and Fixtures and then introduce the piston in the cylinder barrel bore.
- 3/ Extract ring compressor and install cylinder barrel on crankcase.

Note: *After the cylinder barrel was reinstalled on the crankcase and before cylinder head mounting, assure cylinder barrel against falling.*

q/ Cylinder head assemble:

- 1/ Replace loosen or damaged cylinder head gaskets with new ones according to the following prescriptions:
Use normal 1.00 mm (0.0394 in.) thick gasket on new, never overhauled engines. If the engine has been already overhauled, it is necessary to ascertain if the cylinder head was not rework during overhaul. In the purpose to reuse cylinder heads with setting surface distorted by vibrations, the overhauling factory reworks this surface. The height between cylinder head surface setting on cylinder barrel and the surface for camcase setting is diminished by 0.2 mm (0.007874 in.). Every cylinder head reworked in this manner is marked with the letter "S" located under the air intake canal on colored background and the complete set (i.e. 6 pieces) is used on engine. In this case, use an abnormal, 0.2 mm (0.007874 in.) thicker gasket. If the cylinder heads have to be removed during operation time and the same (reworked as described during overhaul) then remounted, abnormal gaskets have to

be used. If it is necessary to replace reworked cylinder head by a new one during operation time, use normal gasket.

When reworked cylinder heads are used, make an entrance in the engine's log book with the following content: "Reworked cylinder heads mounted on engine."

- 2/ Apply graphite grease on cylinder head stud threads.
- 3/ Install cylinder heads on barrels and slightly tighten the nuts.
- 4/ Align cylinder heads to have the air intake ports in the same plane.
- 5/ Using a torque wrench, torque cylinder head nuts to 29.4 Nm (21.69 ft. lbs.).

Note: *The nuts should be progressively cross torqued (see fig. 7-2).*

- 6/ After the nuts were torqued, loose them by turning back about 120° and then progressively cross torque them again to 24.5 Nm (18.1 ft. lbs.)
- 7/ Install camcase gaskets having the same thickness.

r/ Camcase reassemble:

- 1/ Turn crankshaft until the drive gear marked teeth match. In this position, the first piston is at TDC at the end of the exhaust stroke and the beginning of the intake stroke. Do not alternate this position while performing the next steps.
- 2/ On cylinder heads tightly install camcases without the vertical shaft and the rubber hose like sealing between oil sump and oil scavenge pump housing from the camcase.
- 3/ Check clearance between steel outlets from oil sump and camcase. Minimum admissible value is 0.5 mm (0.0197 in.). The normal service value is 1 mm (0.0394 in.), see Fig. 7-11.

Note: *If the clearance is too small, engine part dilatation caused by heating induces supplementary forces in the rear end of the camcase, which can damage it (cracks). In this case, remove camcase and file frontal areas from each steel outlet to min. prescribed clearance at least. Following filing, chamfer outlets edges, clean them and prepare for assemble. If the clearance meets requirements, remove camcase and prepare for assemble.*

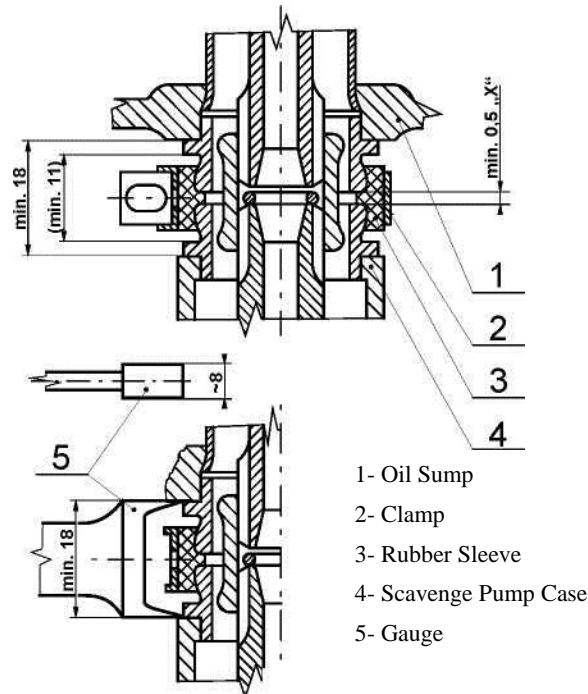

Fig. 7-11

- 4/ Lubricate camshaft mechanism in camcase with oil. Turn camshaft till the rockers from the first cylinder are in crossed position, i.e. exhaust valve closes, intake valve opens. This positioning corresponds to the marks on the camshaft bevel gear drive.
- 5/ On the prepared camcase, install the rubber hose like sealing with the clamp to the oil sump outlet, then the lower grooved spline bushing of the vertical drive shaft, the vertical drive shaft and the upper grooved spline bushing. Install both grooved splines with the shorter grooved portion to camcase.

- 6/ Fix camcase at the first and last cylinder head by means of the auxiliary screws and nuts (the longer studs). Facilitate the grooved spline bushings to engage performing short, oscillatory movements with the crankshaft.
- 7/ Fasten sealing clamp against oil sump applying an average force, while allowing a visible gap between rubber and flange in vertical direction. Loose camcase to cylinder heads fixing nuts to eliminate a possible lack of coaxiality of the vertical drive created in the rubber connection.
- 8/ Progressively screw and tighten the normal, service bolts and secure them.

s/ Check valve operating mechanism for correct timing:

- 1/ Screw on the TDC indicator (see Special Tools and Fixtures) in the spark plug insert at cylinder no.1.
- 2/ Install the dial indicator to crankshaft, see Special Tools and Fixtures.
- 3/ Turn crankshaft until piston no. 1 is at TDC on compression stroke.
- 4/ Adjust valve clearance to 0.25 mm (0.98 in.) for all valves and check valve opening and closing moments:

exhaust valve opens	65° BBC
exhaust valve closes	25° ATC
intake valve opens	25° BTC
intake valve closes	65° ABC
common tolerance	±2°

Note: Indicated valve timing values are theoretical, i.e. at rocker to valve contact, without taking into consideration valve spring deformations. The actual values measured during valve opening and closing are about 5° ÷ 7° shorter.

- 5/ Adjust valve clearance in accordance to the procedure prescribed in this section.
- 6/ Execute the engine run-in according to the process described in section 5

19. ASSEMBLY TOOLS

Together with engine delivery will every customer obtain the bag with assembly tools according to below mentioned list. 1 piece from every item. In case of loosing or destroying, it is possible to order by engine manufacturer.

Serial No.	Name	Ordering number
1	Tool kit	Sc 0870
2	Wrench, supercharger nuts	Sc 0873
3	Wrench, spark plug	Sc 0876
4	Screwdriver, special	Sh 0873
5	Wrench, air inlet elbow nut	Sh 0871
6	Wrench, air manifold, -greater nuts	Sh 8720 (only for M337 a M137)
7	Wrench, air manifold, -smaller nuts	Sh 8723
8	Wrench, camcase plug	Sc 8702
9	Pliers, combination, 180	ČSN 23 0380
10	Wrench, double, open end 5.5x7	ČSN 23 0611
11	Wrench, open, box-end combined,8	ČSN 23 0406.7
12	Wrench, open, box-end combined,9	ČSN 23 0406.7
13	Wrench,open,box-end combined,10	ČSN 23 0406.7
14	Wrench,open,box-end combined,12	ČSN 23 0406.7
15	Wrench,open,box-end combined,13	ČSN 23 0406.7
16	Wrench,open,box-end combined,14	ČSN 23 0406.7
17	Wrench,open,box-end combined,17	ČSN 23 0406.7
18	Wrench,open,box-end combined,19	ČSN 23 0406.7
19	Wrench, double, open end 19x22	ČSN 23 0611
20	Wrench, oil sump strainer, 24x 27	ČSN 23 0637
21	Wrench, oil sump strainer, 22x 24	Sh 8731
22	Wrench, socket, 9	Sh 0875
23	Wrench, socket, 10	Sh 0876
24	Wrench, socket, 12	Sh 0877
25	Wrench, socket, 14	Sh 0878
26	Valve clearance measuring device	Sh 0879
27	Magneto assembly wrench	Sh 0872
28	Screwdriver NAREX 8000/1	č. 8000/1

OPERATOR'S MANUAL

Serial No.	Name	Ordering number
29	Screwdriver NAREX 8000/9	č. 8000/9
30	Screwdriver NAREX 8000/13	č. 8000/13
31	Wrench, valve clearance adjust	Si 8712
32	File, buzzer contacts clearing	5001.71

20. SPECIAL TOOLS AND FIXTURES

The below outlined tools and fixtures facilitate to perform some of the works indicated on procedures contended in this SECTION. These tools and fixtures are not delivered together with the engine, but the customer can order them to the manufacturer.

Name	Ordering number	
	Old ordering number	New ordering number
Extractor, piston pin	Z1-00265-00	P332-1295
Compressor, piston ring	Z1-01529-00	P332-1567
Dowel, piston pin retainer	Z2-01503-00	P332-1196
Indicator, crankshaft rotation dial	Z3-00172-00	P332-1568
Indicator, top dead center	Z3-00260-00	P332-1305
Wrench, socket, 9mm	Z3-00485-00	P332-1203
Wrench, tube, 7mm	Z4-00257-00	P332-1202
Wrench, 9mm	Z4-00511-00	P332-1367
Wrench, socket, 14mm	Z4-00514-00	P332-1204
Cutter, intake valve seat	4-95 Sc 0270/2	N137-009
Cutter, exhaust valve seat	4-95 Sc 0270/3	N137-010
Cutter, exhaust valve seat, final	4-95 Sc 0270/4	N137-070
Plate, cylinder head mounting	6-95 Sc 0270/1	P332-1569
Support, cylinder head	6-95 Sc 0270/9	P332-1570
Lever, valve spring mounting	6-95 Sc 0270/10	P332-1571
Fixture, silentblock check	6-94 Sc 0546/1	P332-1572
Wrench, adjust screw	8-95 Sc 0001/4	P332-1573

Adapter, torque wrench	8-95 Sc 0001/7	P332-1368	
Wrench, 7mm	8-95 Sc 0001/12	P332-1369	
Wrench, supercharger	8-95 Sc 0001/14	P332-1370	
Driver, intake seat	8-95 Sc 0270/5	P137-011	
Driver, exhaust seat	8-95 Sc 0270/6	P137-012	
Driver, intake valve	8-95 Sc 0270/7	P137-013	
Driver, exhaust valve	8-95 Sc 0270/8	P137-013	
Stand, engine	Z1-01573-05	P332-1285	
Wrench, crankshaft nuts	Z3-00154-01	P332-1296	
Wrench torque	12-3-3096/21-10-9		
			OMK-100(0 to 100Nm)
			OMK-500(100 to 500Nm)
Printer, figure, 1,2,3,4,5,6 size 3mm	-	-	-
Fixture, piston pin retainer mounting	Z2-01503-01	P332-1446	

Note: Above mentioned torque wrench is able to substitute by other torque wrench with corresponding range of torque.

Attention: Compression gauge, torque wrench and valve clearance gauge must be inspected and calibrated regularly. It is possible to order the calibration at engine manufacturer.

Page without text

SECTION 8

TROUBLE - SHOOTING

1/ Failure of engine to start	8-2
2/ Difficult engine start	8-2
3/ Engine starts, but it stops several rotations after	8-3
4/ Uneven running	8-3
5/ Rough engine	8-4
6/ Rigid engine running	8-5
7/ Excessive engine temperature	8-5
8/ Engine firing in the exhaust stack or black exhaust smoke	8-6
9/ Engine back firing	8-6
10/ Failure of engine to develop full power and attain full RPM when throttle fully opened	8-7
11/ Proper engine operation at increased RPM, but failure of engine to idle properly	8-7
12/ Engine stops or shows great RPM drop when one magneto switched off	8-8
13/ Engine experiences self-ignition after magnetos switched off	8-8
14/ Increased fuel consumption	8-9
15/ None or low oil pressure indication after engine started	8-9
16/ Sudden oil pressure drop during engine running	8-10
17/ Sudden engine stop	8-10
18/ Failure of ignition system	8-11

Attention: *If during Trouble-Shooting are to be applied procedures prescribed at the 10- and 50-Hour inspections, these may be performed by a mechanic certified by the aviation Authority for care of the specified aircraft type. Repairs exceeding the 10- and 50- Hour inspections volume should be performed by a mechanic from engine's manufacturer or trained and certified by approved organization.*

1. FAILRE OF ENGINE TO START

PROBABLY CAUSE	REMEDY
a. Ignition failure.	See § 18 of this section
b. Improper functioning of the starting vibrator	Check and service starting vibrator according to procedure in section 7.
c. Manual priming failure	Check hand priming pump and nozzles. Replace if necessary.
d. Supercharger starting clutch slip.	Adjust according to procedure noted in section 7.
e. Damage of starting magneto intake wire.	Replace damaged wires.
f. Magnetos core is dirty and Gear/teeth system can not be putted out.	Clean magnetos core.

2. DIFFICULT ENGINE START

PROBABLE CAUSE	REMEDY
a. Improper throttle set	Set throttle to position indicated in section 5.
b. Enriched mixture by hand priming when hot engine	Wait a moment, then repeat without priming. Observe procedure for hot engine starting.

- | | |
|--|---|
| c. Excessive burnt off starting vibrator points. | Service and maintain buzzer according to procedure indicated in section 7. Possibly replace. |
| d. Excessive spark plugs wear. | Replace spark plugs. |
| e. Dirty or burnt off magneto breaker points. | Service magneto according to procedure in section 7. If short time repeated trouble, replace capacitor. |

3. ENGINE STARTS, BUT IT STOPS SEVERAL ROTATIONS AFTER

PROBABLY CAUSE

REMEDY

- | | |
|--|--|
| a. Lack of sufficient fuel flow caused by clogged fuel strainer or leaks at fuel system connections. | Clean fuel strainer, check tightness of all connections. |
| b. Flooded spark plugs and humid wiring | Dry spark plugs by warming up above 100°C (212°F), wipe wiring. |
| c. Water in fuel and/or in injection pump. | Drain and renew fuel, rinse fuel lines with clean fuel. |
| d. Injection pump does not deliver fuel. | Remove one fuel nozzle and cranking engine from propeller, while ignitions is Off, check if fuel flows. Replace Possible defective injection pump. |

4. UNEVEN RUNNING

PROBABLE CAUSE

REMEDY

- | | |
|---|---|
| a. Insufficiently warmed up engine after starting | Warm up engine a longer time according to procedure in section 5. |
|---|---|

- | | |
|---|---|
| b. Insufficient fuel flow due to clogged fuel strainers. | Clean fuel strainers. |
| c. Incorrect valve clearance | Adjust valve clearance according to procedure indicated in section 7. |
| d. Incorrectly matched valve operating mechanism after repair. | Verify theoretical valve timing according to specifications in section 3. |
| e. Incorrect magneto timing | Readjust magneto timing according to procedure in section 7. |
| f. Defective short-circuit conductor. | Apply as indicated by airframe manufacturer's procedures. |
| g. Incorrect mixture set. | Check mixture set; possibly adjust mixture. |
| h. Continuously opened injection nozzle due to foreign particles. | Visually check nozzle orifice, replace defective one. |
| i. Cracked injection line. | Check for leaks while hand cranking; replace defective lines. |

5. ROUGH ENGINE

PROBABLY CAUSE

REMEDY

- | | |
|---|---|
| a. Defective injection nozzle | Check nozzles, replace defective one(s). |
| b. Incorrect propeller or propeller hub assembling. | Observe procedure for propeller assembling mounting in the propeller manufacturer's manual. |
| c. Different angles with variable pitch propeller | Check basic propeller blade mounting angle according to propeller manufacturer's prescriptions. |

- | | |
|---|---|
| d. Insufficient rigid engine mounting onto airframe | Verify engine mounting according to airframe manufacturer's prescriptions. The rubber shock absorbers must have sufficient clearance against metal parts to avoid rough contact during engine movements. Replace defective or improper shock absorbers. |
| e. Defective magneto. | Selecting between magnetos, identify the defective one and replace it. |
| f. Defective spark plug(s). | Check spark plugs; replace defective one(s). |
| g. Defective ignition harness. | Replace wires. |

6. RIGID ENGINE RUNNING

- | PROBABLY CAUSE | REMEDY |
|---------------------------------|---|
| a. Improper fuel grade. | Renew fuel according to specifications in section 4. |
| b. Incorrect magneto timing | Adjust magnetos according to specifications in section 7. |
| c. Incorrect mixture adjustment | Verify basic adjustment of the injection pump mixture correction. See 500/1,500 Hour inspection in section 6, Fig. 6-1. |

7. EXCESIVE ENGINE TEMPERATURE

- | PROBABLY CAUSE | REMEDY |
|----------------------------------|---|
| a. Incorrect mixture adjustment. | Verify basic adjustment of the Injection pump mixture correction. See 500/1,500 Hour inspection in section 6, Fig. 6-1. |

- | | |
|--------------------------------|--|
| b. Incorrect magneto timing | Adjust magnetos according to specifications in section 7. |
| c. Defective temperature gauge | Test temperature gauge by replacing thermocouple under spark plug and temperature indicator. |

8. ENGINE FIRING IN THE EXHAUST STACKS OR BLACK EXHAUST SMOKE

- | PROBABLE CAUSE | REMEDY |
|---|---|
| a. Incorrect mixture adjustment | Verify basic adjustment of the injection pump mixture correction. See 500/1,500 Hour inspection in section 6, Fig. 6-1. |
| b. Incorrect mixture control set in cockpit | Observe operating instructions shown in section 5. |
| c. Incorrect valve clearance adjustment. | Adjust valve clearance according to specifications in section 7. |
| d. Incorrect magneto timing. | Adjust magnetos according to specifications in section 7. |

9. ENGINE BACK FIRING

- | PROBABLE CAUSE | REMEDY |
|---|---|
| a. Insufficient fuel flow caused by failure in the fuel system. | Visually check fuel lines, clean fuel strainers, replace injection pump if defective. |
| b. Defective gasket between air Intake pipe flange and cylinder head. | Check gasket for condition. |
| c. Incorrect mixture control set in cockpit. | Observe operating instructions shown in section 5. |
| d. Incorrect valve clearance adjustment | Adjust valve clearance according to specifications in section 7. |

- | | |
|------------------------------------|--|
| e. Improper intake valve operation | Check valve stem in the valve guide.
Replace defective (broken) valve spring. |
| f. Incorrect magneto timing. | Adjust magnetos according to specifications in section 7. |

10. FAILURE OF ENGINE TO DEVELOP FULL POWER AND TO ATTAIN FULL RPM WHEN THROTTLE FULLY OPENED

PROBABLE CAUSE	REMEDY
a. Incorrect magneto timing	Adjust magnetos according to specifications in section 7.
b. The angle of attack of the variable pitch propeller blades is too great.	Adjust propeller according to propeller manufacturer's prescriptions.
c. Insufficient cylinder compression.	Check compression in each cylinder according to instructions in section 7.
d. Engine too hot or too cold.	Cool or warm up engine according to instructions in section 7.
e. Insufficient boost pressure.	Consider boost pressure in relation with the ambient air pressure, check supercharger if engaged, check air strainer for condition, replace if clogged
f. Water in the fuel strainer	Clean fuel strainer.

11. PROPER ENGINE OPERATION AT INCREASED RPM, BUT FAILURE OF ENGINE TO IDLE PROPERLY

PROBABLE CAUSE	REMEDY
a. Clogged or restricted air nozzle orifice of the fuel corrector adjustment valve.	Clean nozzle.

- | | |
|-----------------------------------|---|
| b. Incorrect idle stop adjustment | Adjust stop. |
| c. Improper magneto operation. | Check and service magnetos according to procedure in section 7; possibly replace. |
| d. Defective spark plugs. | Service spark plugs according to procedure in section 7 or replace. |

12 ENGINE STOP OR SHEWS GREAT RPM DROP WHEN ONE MAGNETO IS SWITCHED OFF

PROBABLE CAUSE	REMEDY
a. Improper magneto operation.	Check and service magnetos according to procedure in section 7; possibly replace.
b. Defective spark plug.	Replace spark plug.
c. Incorrect magneto timing	Adjust magnetos according to specifications in section 7.

13. ENGINE EXPERIENCES SELF-IGNITION AFTER MAGNETOS SWITCHED OFF

PROBABLY CAUSE	REMEDY
a. Considerable spark plug fouling.	Check and maintain spark plugs according to procedure in section 7 or replace.
b. Insufficient engine cooling.	Keep instructions for engine operating

14. INCREASED FUEL CONSUMPTION

PROBABLE CAUSE	REMEDY
a. Improper mixture setting.	Observe operating instructions shown in section 5.
b. Leaks in fuel system.	Check fuel system and retighten.
c. Incorrect basic adjustment of the injection pump.	The injection pump basic adjustment was performed by the engine manufacturer and entered in the pump attest. This attest is part of the engine accompanying documents. Entrust readjustment to an engine manufacturer's employee or trained and certified by approved organization.

15. NONE OR LOW PRESSURE INDICATION AFTER ENGINE STARTED

PROBABLY CAUSE	REMEDY
a. Insufficient oil.	Fill with according to specifications in section 4.
b. Stoppage in oil circuit caused by clogged oil strainers.	Clean oil strainers.
c. Stoppage in oil pressure lines to oil pressure gauge.	Clean oil lines according to aircraft manufacture's procedure.
d. Defective oil pressure transmitter.	Replace transmitter or gauge.
e. Friction of increased oil pressure valve (piston).	Clean the valve piston and execute its right tightening or replace increased oil pressure valve.

16. SUDDEN OIL PRESSURE DROP DURING ENGINE RUNNING

PROBABLE CAUSE	REMEDY
a. Insufficient oil in tank	Fill tank according to specifications in section 4.
b. Leaks in oil system.	Check oil system for leaks, retighten.
c. Air lock in oil system due to failure of tightness	Check oil system for leaks, retighten.
d. Oil pump failure.	Replace oil pump, possibly check pressure oil valve for condition and readjust according to oil pressure adjustment procedure in section 7.
e. Defective oil pressure gauge.	Replace gauge.

17. SUDDEN ENGINE STOP

PROBABLE CAUSE	REMEDY
a. Insufficient fuel flow caused by stoppage in fuel line or by clogged fuel strainer.	Clean fuel strainers and lines.
b. Failure of ignition system.	See § 18 in this section.
c. Internal engine failure.	Dispose general engine inspection.
d. Failure inside injection pump or of its drive.	Dismount injection pump; possible replace it.

18. FAILURE OF IGNITION SYSTEM

PROBABLE CAUSE	REMEDY
a. Defective spark plugs.	Service and check spark plugs according to procedure in section 7; replace defective ones.
b. Failure of magnetos.	Check, service and adjust magnetos according to procedure indicated in section 7; possibly replace.
c. Defective ignition wires.	Check wires and individual leads for proper connections. Replace leads with damaged insulation coat.

Page without text

SECTION 9

ENGINE SHIPPING, STORAGE, INSTALLATION

1/ Transport and Storage	9-2
2/ Engine Installation and Dismount	9-4
3/ Demands for Installation	9-7

1. TRANSPORT AND STOREAGE

The engine is packed up in PE cover and is replaced in case on transporting stand, fixed to lateral sides of case.

Note: PE cover is the part of engine protection, therefore remove the engine from case only when you need to place engine to the airframe. Damage of PE cover causes partial degradation of engine protection, what is non acceptable for further storage.

- a/ Procedure of engine remove from case:
- 1/ Open the case cover.
 - 2/ Unscrew the engine stand from case sides.
 - 3/ Using the elevating facility remove the engine from case taking for suspensions eyes/13/, picture 9-4 together with stand.
 - 4/ Release transport-fixing footings and take out the engine from stand.

Attention: By transportation and handling with engine, it is necessary to fix to frame magnetos against spontaneous engine starting by crankshaft turn. Execute perfect electrical contact of both engine magnetos short circuit wires by copper non insulated wire – dia min. 0,8mm (0.0315 in.) with screw on engine acc. to picture 9-1.

- b/ Procedure of engine seating to the case:
- 1/ Using blinds, cap nuts and hoods close all engine openings and pipe unions.
 - 2/ Execute the electrical connections of magnetos acc. picture 9-1.
 - 3/ Cover the engine with PE film and seat into transporting stand.
 - 4/ Seat the engine into case using elevating facility and fix by reverse way as by remove.

Note: In this way it is possible to transport the engine only for short distance and for only few days. By longer distances, shipment or storage protect the engine, put together with engine drying facilities and cover water-proof with PE film. For protection of engine keep all procedures described in section 10 of this manual.

Store engine afterwards in dry place with minimum fluctuations in temperature.

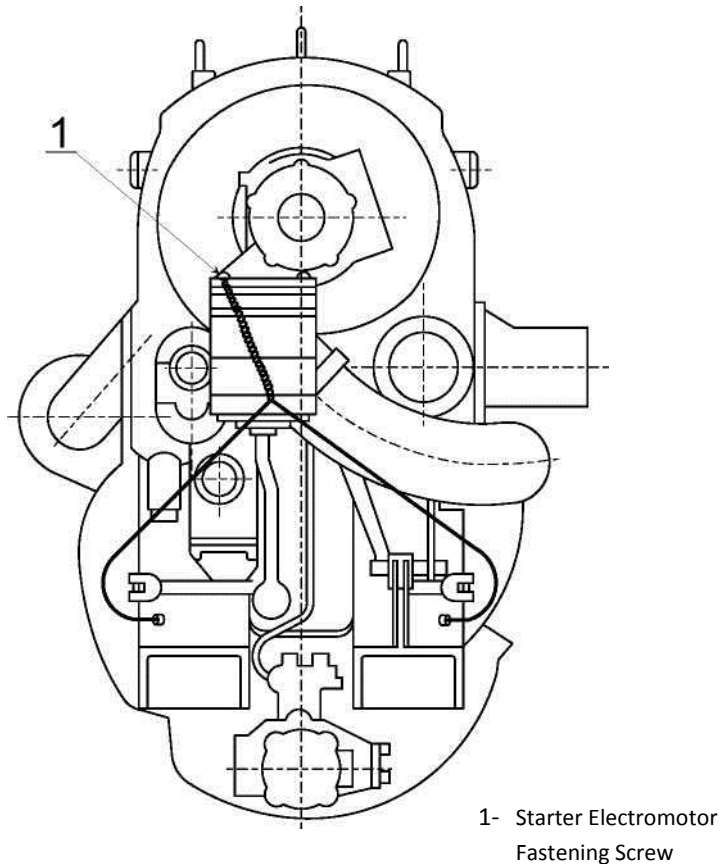

Fig. 9-1

2. ENGINE INSTALLATION AND DISMOUNT

A. Engine mounting to the aircraft

Below mentioned positions are described on 9-13 – 9-17 pictures in rear part of this manual.

- a/ Hang the engine after taking out from the stand using suspension eyes /13/ and rope of elevating facility.
- b/ Deprotect the engine according the procedure mentioned in section 10 of this manual.
- c/ Put corresponding sealing between flanges of engine and additional eggs.
- d/ Fix fastening foots with hinged pins for assembly to engine bed.

Note: By engine mounting to the aircraft engine bed keep the procedure described in aircraft manufacturer's manual. Especially keep the prescribed torque moment, to protect insertion pieces of fastening flanges in engine case. Torque moment is $15,7+2 \text{ Nm}$ ($11.6 + 1.5 \text{ ft.lbs.}$). Secure screws by securing packing piece according to aircraft manufacturer's manual.

- e/ Connect fuel pull rod to fuel lever /9/ on console. Connect to correction lever /10/ the pull rod of manual correction and to pull rod of saturator corresponding control /acc. engine equipment/. Pull rod of supercharger connect to starting supercharger lever /12/ (M332/337). Pull rod pins secure with split pin.
- f/ Take out the blind from supercharger entering breather /2 - M332/337/ flange and connect air suction pipe. By M132/137 engines air suction pipe has to be connected to entering breather flap.
- g/ Connect the intake tubing to fuel entering connection /14/ pic. 9-2 on injection pump. Connect the corresponding tubing to fuel manometer connection /15/ and connect the corresponding tubing directed into fuel tank to the injection pump deaeration /16/. Also connect wasted tubing to drain valves /2/ for fuel waste from suction elbows /pict.9-3/.

h/ After blindings taking out, connect the piping for oil from engine tank driving to oil entering /22/ and to oil outlet /23/ connect the piping for oil transporting from engine into oil tank.

Note: *Rinse the pipes before assembly by clean technical fuel and blow through with pressurized air to eliminate mechanical impurities. By assembly take a care for tightness of connections to prevent oil leakage from installation or aeration.*

i/ Connect the tubes after blinding take out to the oil pressure connection /25/. Assembly the oil entering temperature indicator to the cleaner cover with adapter for thermometer /26/.

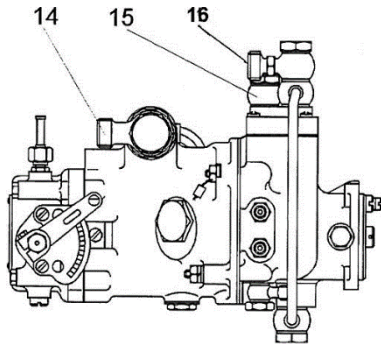

Fig. 9-2

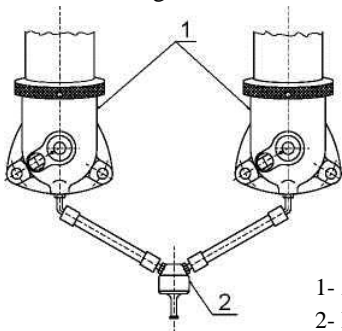

Fig. 9-3

1- Air intake elbows
2- Fuel drain valve

OPERATOR'S MANUAL

j/ Connect to both magnetos short-circuits wires from magnetos breaker into short-circuits outputs /31/. Short - circuit wires connect well to the clean engine metal and test conductive connection.

k/ Connect corresponding cable lines to starter terminal connectors /32/ and dynamo /33/.

Note: *Whole electric installation must be insulated carefully and wires may not touch sharp edges of airframe. Connection to the engine has to be elastic because of engine vibration.*

l/ Mount the temperature sensor onto corresponding cylinder head / under plug on suction side/. By 4-cylinder on 3rd head, by 6-cylinder engine on 4th head.

m/ After blind remove , mount onto flange of electric engine speed indicator driving mechanism transmitter/34/ corresponding engine speed indicator transmitter or connect flexible shaft of mechanic engine speed indicator to mechanic engine speed indicator connection /35/ on oil pump after blinding unscrewing.

n/ Take out the blinding of engine case deaeration /27,28/ and connect deaeration pipe with output to the underpressure place.

o/ Take-out blindings of exhaust flanges /7/ and assembly exhaust pipes, alt. exhaust collector. Insert corresponding sealing between heads and exhaust pipes.

p/ Assembly the propeller onto engine crank shaft. Assembly corresponding propeller speed regulator onto flange /5/. For the assembly keep the proceeding acc. the propeller's manufacturer.

q/ Place and fix engine cover.

Note: *All blinding nuts and cups keep for further using by engine disassembly from airframe.*

B. Engine Dismount From Airframe

Dismounting of engine from the airframe execute by contrary way than assembly but do not forget as the first step is to discharge the oil from the engine. If necessary preserve the engine according the instructions described at section 10 of this manual.

3. DEMANDS FOR INSTALLATION

Attention: *Every new engine installation by new or rebuilt aircrafts must be permitted by designing dept. of manufacturer; otherwise warranties are no more valid.*

A. Fuel installation

Fuel is supplied to the injection pump by flexible tubes of inner dia-8 mm (0.0315 in.). By piping installation it is necessary to avoid sharp elbows and folds, especially in vertical plane, because in these folds can easy assemble air or water. The fuel is sucked into injection pump by its own fuel pump. To the supplying fuel piping must be inserted closing cock and fuel cleaner with particle permeability up to 0,03mm (0.0012in.). Also the fuel installation has to be equipped with pump for piping and injection pump priming by fuel before starting. Connect the piping of returned fuel inner dia - 6mm (0.2362in.) to deaeration union nut of injection pump. Pipes to fuel pressure gauge inner dia 4mm (0.1575in.) connect onto corresponding union nut on injection pump. Excessive fuel from suction knees, which flows through overflowing valve is the best to set out by shortest piping out from the aircraft.

B. Oil installation

By piping installation it is necessary to avoid sharp folds and elbows. Inlet pipe must have min. inner dia - 20 mm (0.7874in.) and inner dia of returned oil piping from engine to oil tank should be min. 10mm (0.3937in.). In the oil inlet for example in oil tank must be introduced oil cleaner with sieve of following dimensions: length of eye side 0,4mm (0.0157in.), wire dia 0,2 mm (0.0078in.) and screen area cca 20,000 mm² (31 sq.in.).

If the oil cooling is insufficient /by unsuitable arrangement of oil tank and cowling/, it is necessary to introduce oil cooler into reverse piping. In bottom oil installation place must be placed outlet cock for total oil discharging from tank, piping and engine.

C. Ignition

In pilot's cockpit is located starter switch, which is connected by short-circuit wires to correspondent magneto grips and to metal of engine /engine is insulated against the engine bed and it is necessary to connect it with bed/.

The switch has to have well marked position ON and OFF and also two other positions for switch on only left or right magneto M1 and M2. Additional equipment for spark advance operating is not necessary, because spark advance happens automatically. For spark intensifying by engine starting is alternatively assembled to the right magneto circuit starting buzzer, optimal with transformer circuit.

D. Engine operating levers

For engine output operation and fuel mixing serves operating levers on the countershaft. The main lever of intake operates fuel cut-off and has adjustable idling stop. The second lever operates manual fuel suction enrichment /by manual correction engine/ or saturator needle /11/ /by automatic correction engine/. Instructions for engine operation are described in section 5 of this manual. For switch on the switch-off satellite gear on supercharger wheel serves lever on the supercharger body. The right supercharger "switch-on and switch-off is possible to check, when - by position ON may not the pressure gauge of air boost higher than the pressure in entering supercharger inlet, mostly 96-100 kPa (28.3 - 29.5 in.Hg.).

Draw bar connecting the countershaft and pilot's cockpit's levers has to be strength enough, well installed against vibration and bending. Connecting joints has to be executed without clearance. Clearance of levers by pilot has to be a little higher than by countershaft levers. Connecting draw bars between engine and airframe has to be /if possible/ parallel to engine axis to protect the location change of operating levers by engine movement in rubber absorbers.

E. Exhaust piping

Together with engine - LOM PRAHA delivers exhaust flanges for which must the customer install exhaust piping, alternat. heat exchanger for aircraft heating /not supplied by LOM PRAHA/. Exhaust gases of each cylinder are forwarded through these pipes out from engine cowling or can be directed to

the exhaust collector and from collector under the aircraft. If it is necessary to use extended exhaust pipes, exhaust collector or silencers, there is necessary to accept, that the outfit may not cause non-adequate weight increasing, inertial powers or heat dilatation.

Note: *All outfits assembled in the exhaust piping causes engine power reduction.*

Attention: *Design office of LOM PRAHA has to permit-exhaust piping design and installation, otherwise the warranty is not more valid!*

F. Engine cowling

The reliable engine operation in the aircraft depends of the optimal cowling design, to reach the optimal cooling in the volume of supposed temperature and air speed. For temperatures (-15 ÷ +30°C)(5 ÷ 86°F) is the standard cowling mostly enough /or with min. adaptation for winter and summer operation. For larger temperature volume it is necessary to execute breathing regulation. Operational temperatures prescribed in engine manual must be kept.

First of all must be kept prescribed minimum pressure cooling air drop /see page 3 - 5/, what is measured before and behind the engine cylinders /by landing and starting/.

Especially take a care for cowling ventilation after engine stop, because heating from the hot cylinder heads causes heating of suction piping with fuel nozzles.

The fuel in nozzles and in fuel piping may not touch the boiling point, otherwise can the engine start spontaneously and make troubles during operation.

The suitable adaptation of cowlings and regulation can assure the right ventilation of fuel installation, by min. speed both max. speed and powers.

In emergency, can be /after the stop/ the engine cowling open.

For winter operation, especially by very low temperatures it is necessary to reduce the cowling ventilation. Fuel injection pump has independent

regulation case cooling taking air by rubber tubing from air reservoir. Do not assemble any other outfit onto the injection pump.

Front engine cover may not be displayed to the straight air flow, on the contrary has to be sheltered against cooling and water condensation, which causes engine corrosion. If the engine is operated in the dust conditions, it is necessary to install before air inlet to the engine, an effective filter, with min. resistance, to keep normal engine power.

Engine installation needs to count with sucked air ram pressure, the same as by cooling air. For optimal engine power is the min. ram pressure in suction branch before supercharger /by M332/337/ the same as min. cooling air pressure in engine pit.

The same min. ram pressure is assumed also by engines without supercharger /M132/137/ on suction piping inlet before air flap. For higher ram pressures from higher speeds is valid boost pressure reduction according to engine power indications.

Attention: *Every engine installation has to be permitted by designer's office of engine manufacturer – LOM PRAHA.*

G. Propeller

The propeller must be adapted to T.O. power by climbing flight, by models with supercharger with supercharger - ON. The propeller must be always well balanced and centered. The contact flange surfaces of propeller head must be clean and work well, to seat the propeller well onto propeller's distributor's flange. All screws must be tighten by prescribed torque moment and theirs nuts secured well. The engine may not work any time with wrong assembled or not balanced propeller. The propeller and distributor assembly is prescribed in the propeller's manufacturer assembly manual.

Attention: *The use of different propeller than recommended and inspected by engine manufacturer must be permitted by designer's office of engine manufacturer – LOM PRAHA.*

**Positions concerning engine pictures sheet 9-13 up to 9-17 sheet,
in the rear part of this manual.**

1. Engine fixing base flange for engine bed
2. Supercharger air inlet branch flange /M332A,AK and M337A,AK/
3. Air inlet branch into suction pipe /M132A,AK/
4. Air inlet branch into suction pipe /M137 AZ/
5. Propeller governor flange
6. Flange for propeller governor electromotor
7. Exhaust flange
8. Exhaust pipe flange
9. Fuel lever
10. Lever of fuel mixture correction /by LUN 5150, or LUN 5150.01 or LUN 5151.02 outfit/
11. Saturator draw bar on correction valve /by LUN 5150.03, or LUN 5150.03 outfit/
12. Supercharger on and off lever /M332A,AK and M337 A,AK/
13. Engine rods
14. Fuel inlet connector
15. Fuel pressure gauge connector
16. Fuel injection pump deaeration connector /returned fuel/
17. Oil discharging plug from injection pump
18. Oil discharging plug from aneroid case
19. Oil filling plug to injection pump
20. Fuel injection nozzle by engine starting
21. Boost pressure in suction pipe pressure gauge connector
22. Engine oil inlet
23. Engine oil outlet
24. Oil tank deaeration connecting place
25. Oil pressure gauge connector
26. Oil cleaner cover with adapter for inlet oil thermometer sensor
27. Engine case ventilation branch /M137,M332,M132 families/
28. Engine case ventilation elbow /M337 family/

29. Oil outlet plug from camcase with cleaner /and gravity valve by M337 AK, M332 AK, M137 A,AZ/
30. Air reservoir openings for disassembly of ignition plugs left row /accessed after pull-out reservoir gate valve/
31. Ignition magnetos short-circuit outlets
32. Starter electro-engine
33. Dynamo
34. Electric transmitter speed indicator driving flange n= 1:1
35. Mechanic speed indicator driving connector n= 1:2
36. Fuel mixture correction lever lubricator
37. Lubricator on lever's console
38. Filling branch of lubricator into starter /M337, M332 family/
39. Outlet branch of lubricator from starter /M337, M332 family/
40. Outlet and filing branch of starter lubricator
41. Electric connection of engine to the engine bed

SECTION 10

ENGINE PROTECTION AND PREPARATION

1/ General 10-2

2/ One Week time Engine Protection 10-3

3/ One Month Time Engine Protection 10-3

4/ Engine Protection For A Period Longer Than 3 Months
..... 10-4

5/ Engine Protection Prior To Newly Putting Aircraft Into
Service 10-6

6/ Injection Pump Protection 10-8

7/ One Week time Injection Pump Protection 10-8

8/ One Month time Injection Pump Protection 10-8

9/ Injection Pump Protection For A Period Longer
Than 3 Months 10-9

10/ Injection Pump Protection Prior To Newly
Putting Aircraft Into Service 10-10

1. GENERAL

The prescribed aircraft engine oils, beside lubricating and heat transferring characteristics, also protect engine inside surfaces against corrosion for a certain time, during engine inactivity (flight activity ceasement). The duration of this period is adversely influenced by several factors increasing the possibility of corrosion during engine inactivity.

These are: Great relative air humidity;
Marine atmosphere (chlorides);
Industrial atmosphere (sulphurous oxide);
Combustion products (TEL scavenging agents);

Combination of these factors having increased corrosion capacity may induce corrosion attack at new engines (e.g. at cylinders) even after two days of inactivity. Engine cylinder walls acquire increased corrosion resistance properties only after about 50 hours operation time, so that such engines can remain inactive for several weeks in favorable climate conditions.

In case that an engine remains inactive in adverse climate condition for a longer time, whose duration is already known, it is necessary to immediately preserve engine for the whole period of inactivity.

2. ONE WEEK TIME PROTECTION

This protection is necessary performed by 7 days from the last engine running, immediately after the last flight in case adverse climate conditions.

a/ Remove spark plugs and spray through these holes inside each cylinder, by means of the hand sprayer, aprox. 100 ccm (6.1 cub. in.) fresh aircraft engine oil grade in accordance with the specifications in SECTION 4, at a temperature of 50°C to 70°C (122÷158 °F), while the piston is at BDC. After each cylinder spraying, crank engine by hand about two turns while ignition and fuel are "OFF". The oil creates a protective layer on cylinder walls and protects the valves. Concomitantly remove frontal lid plug and spray engine oil grade according to the specifications in SECTION 4,

heated to a temperature of 50÷70°C (122÷158°F), against the pressure ball bearing and the frontal end of the crankshaft. Reinstall spark plugs and plugs.

- b/ Obturate exhaust and air manifold inlet. Install engine cowling fabric covers to protect against dust and humidity.
- c/ Protect injection pump in compliance with pertinent prescription indicated in this section.
- d/ This preservation can be repeated twice or three times, if the engine was immediately preserved after the last flight because of adverse climate conditions. Perform repetition within 7 days without engine restarting.

Attention: *Group running the engine for brief periods of time is not a substitute for the above prescribed protection, but on the contrary, it tends to aggravate the corrosion condition.*

3. ONE MONTH TIME ENGINE PROTECTION

- a/ Perform preservation while oil in the engine is min. 50÷70°C (122÷158°F) hot.
- b/ Drain all oil in engine and oil tank and substitute with new engine oil according to specifications in SECTION 4 of this manual. Then turn the engine several times by hand.
- c/ Remove spark plugs and spray through these holes inside each cylinder, by means of the hand sprayer, aprox.100 ccm (6.1 cub. in.) fresh aircraft engine oil grade in accordance with the specifications in SECTION 4, at a temperature of 50°C to 70°C (122÷158°F), while the piston is at BDC. After each cylinder spraying, crank engine by hand about two turns. Reinstall spark plugs.
- d/ Remove frontal lid plug and spray aprox.100 ccm (6.1 cub. in.) fresh aircraft engine oil grade according to the specifications in SECTION 4, heated to a temperature of 50÷70°C (122÷158°F), against the pressure ball bearing and the frontal end of the crankshaft. Reinstall and plug.
- e/ Obturate exhaust and air manifold inlet and crankcase breather in the top lid. Preserve injection pump in compliance with pertinent prescription indicated in this section.

- f/ Install engine cowling fabric covers to protect against dust and humidity.
- g/ This preservation can be repeated two times, but without to repeat steps a/ and b/. Three times repeated 1 Month Time Preservation can be substituted by a Preservation for a Period Longer than 3 Months.

4. ENGINE PROTECTION FOR A PERIOD LONGER, THAN 3 MONTHS

- a/ Let engine run at about 1200 RPM before final shut down, close fuel and let engine turn as long as it surges all fuel contained in lines and injection pump. The engine is assumed to have 50÷70°C (122÷158°F) hot oil prior to shut down.
- b/ Drain all oil from engine and oil tank and remove spark plugs.
- c/ While continuously cranking engine, remove plug in the frontal lid and fill crankcase with preservative oil in compliance with specification MIL-L-6529 C Type 1 heated to 50÷70°C (122÷158°F), e.g. EXXON RUST BAN 631 or AERO SHELL Fluid 2XN.
- d/ When the crankcase is full with preservative oil, drain this oil, which can be reused for preservations, provided that it was not contaminated with dirty or other foreign elements.
- e/ Through the spark plug holes, spray the interior of each cylinder with approximately 100 ccm (6.1 cub.in.) MIL-L-6529 C Type 1 preservation oil heated to 50÷70°C (122÷158°F) by means of the manual sprayer. The piston must be at BDC during spraying and consequently to this, crank engine about two revolutions so that an oil coat form to protect cylinder inside walls and valves.
- f/ Install drying plugs containing blue silica gel indicator instead of spark plugs.
- g/ Perform following works:
 - 1/ Wrap both magnetos in paraffin paper or plastic foil and thoroughly secure with cord.
 - 2/ Protect injection pump conform to the procedure in this SECTION.

- 3/ Wrap starter electric motor in paraffin paper or plastic foil and secure with cord.
 - 4/ Apply thin protection oil coating to the ignition cable terminals.
- h/ Obturate all engine exterior orifices (exhaust manifold, air manifold inlet, generator cooling air inlet, crankcase breather, etc.) using duly plugs, covers and obturators.
- i/ Preserve spark plugs in a 5% engine oil in gasoline solution.
- j/ It is permitted to repeat once again this preservation after 6 months storage, provided that the previous preservation was removed and without engine starting. After 12 months from the first preservation, perform the following operations:
- 1/ Check engine exterior surface for evidence of corrosion. Remove evidenced corrosion and protect by emailing, for instance.
 - 2/ In case of adverse storage conditions or if protection record data are missing, let duly manufacturer's mechanic or a mechanic trained and/or certified by the engine's manufacturer check engine interior for corrosion appearance. This check can be performed through spark plug holes or by removing the top crankcase lid. The engine can possibly undergo operations presented in steps 3/, 4/ and 5/ of this procedure.
 - 3/ Inspect all crankshaft arms along the whole contour while manually cranking engine and all steel made parts inside engine crankcase (connecting rod bolts and nuts, bearing pad main bolts, drive gears, frontal pressure bearing and possibly the camshaft).
 - 4/ Remove rust deposits by cleaning with petrol or polishing with fine abrasive paper. Thoroughly clean the polished spots to remove remained dirt.
 - 5/ Deep rust spots, that cannot be removed using abrasive paper, are not acceptable. In this case, the engine must undergo an overhaul procedure in engine's manufacturer or in a repair factory authorized by him.

Note: Use MIL-L-6529 C Type 1 protective oils (e.g. EXXON "RUN BAN 631" or AERO SHELL FLUID 2XN) strictly in accordance with manufacturer's instructions.

Attention: Apply visible markings (e.g. red colored lines) to indicate that desiccant bags were installed in exhaust stacks and air inlet manifold so that they can be remembered to be removed during engine preparation for flight. On a visible location, place the following inscription: **ENGINE PRESERVED. DO NOT ROTATE CRANKSHAFT.** The desiccant plugs installed in spark plugs holes must be periodically checked. When the content of silica gel changes to a pink coloration (the original coloration is blue), this indicates that the preservation should be repeated.

5. ENGINE PREPARATION PRIOR TO NEWLY PUTTING AIRCRAFT INTO SERVICE

The volume of work required by newly putting engine into service depends upon the storage duration and preservation procedure.

- a/ If no preservative oil was used, perform in addition to Pre-Flight Inspection following operations before first engine starting:
- 1/ Remove all protective covers, obturators and plugs and other corrosion preventive means (desiccant bags, etc.).
 - 2/ Remove one spark plug from each cylinder and spray approximately 100 ccm (6.1 cub.in.) of fresh engine oil grade heated to 50÷70°C (122÷158°F), while the piston is at BDC, i.e. at the center closer to crankshaft. After each spraying, crank engine about two rotations, so that the sprayed oil forms a film on cylinder walls and valves. Install spark plugs.
- b/ On engines, at which MIL-L-6529 C Type 1 preservative oil grade was used, perform next operations followed by the 50-Hour Inspection, before newly putting engine into service.

Attention: Remove engine protection exactly before putting into service.

- 1/ Remove all plugs, covers, obturators and desiccant plugs. Install dummy spark plugs (rejected spark plugs for instance). Drain remained preservative oil from engine, while rotating the crankshaft.

Note: To facilitate remained oil draining, especially when cold weather, it is recommendable to preheat engine from an external source.

- 2/ Remove plugs from camcase and spray the interior with fresh engine oil grade in accordance with the specification in SECTION 4, heated to $50\pm 70^{\circ}\text{C}$ ($122\pm 158^{\circ}\text{F}$).
- 3/ Remove one dummy spark plug from each cylinder and spray approximately 100 ccm (6.1 cub.in.) of fresh engine oil grade conformly to the specification in SECTION 4, heated to $50\pm 70^{\circ}\text{C}$ ($122\pm 158^{\circ}\text{F}$), while the piston is at BDC, i.e. at the center closer to crankshaft. After each spraying crank engine about two rotations, so that the hot sprayed oil forms a film on cylinder walls and valves. Reinstall dummy spark plugs. Remove dummy spark plugs from the other side and repeat.
- 4/ Install spark plugs and strainers to engine after they were cleaned and inspected.
- 5/ Check ignition wire terminals for condition and then connect them to spark plugs.
- 6/ Disconnect oil hose from oil pump inlet, fill it fully with hot fresh engine oil and connect it back.
- 7/ Fill oil tank with prescribed quantity of hot fresh engine oil grade conforming to the specifications in SECTION 4.
- 8/ Clock wisely rotate propeller several revolutions by hand to prime the oil pump.
- 9/ Start engine and let it run for about 20-30 minutes, in the first phase at 1000 RPM, than increase to 1500 RPM. Thoroughly warm up engine: oil inlet temperature must be at least $40\pm 50^{\circ}\text{C}$ ($104\pm 122^{\circ}\text{F}$).
- 10/ Remove magneto distributor blocks and clean terminals and contacts with a fine brush dipped in trichlorethylene or gasoline. Dry well the distributor (blow with compressed air jet) and reinstall the distributor blocks. Fill oil tank with oil grade conforming to the specification in SECTION 4. Prepare the aircraft in compliance to aircraft manufacturer's prescriptions and fly a horizontal test flight. Check oil in the oil tank for condition after the test flight. Clean all oil screens and strainers. Replace oil in case of excessive oil foaming.

Attention: *If MIL-L-6529 C Type 1 protective oil grade was used for engine protection, change engine oil (in accordance with the specifications in SECTION 4) after the first 10 hours operation time following newly putting engine into service. Always observe*

this principle, if preservative oil is used for internal engine conservation.

Note: *All protections and associated repetitions, as well as all engine inspections and oil changes must be entered to the engine log-book under the date of performance and responsible employee's signature.*

6. INJECTION PUMP PROTECTION

In course of the aircraft flight operation cancellation, it becomes necessary to service and to preserve periodically the injection pump to avoid deterioration. If engine and injection pump are canceled from flight operation for a longer time, whose duration is known, it is necessary to perform immediately the preservation corresponding to the duration, during the first 5 hours following the final engine shut down, in case of adverse climate conditions.

7. ONE WEEK TIME INJECTION PUMP PROTECTION

Perform 1 Week Time Injection Pump Protection concomitantly with the similar engine protection.

- a/ Remove right side plug and spray the interior through the hole with 150 ccm (9.15 cub.in.) fresh engine oil grade in compliance to the specification in SECTION 4, heated to $50\pm 70^{\circ}\text{C}$ ($122\pm 158^{\circ}\text{F}$), until the oil begins to overflow through the hole.
- b/ Reinstall the plug.

Note: *The foregoing preservation can be repeated two or three times in compliance with the similar engine protection.*

8. ONE MONTH TIME INJECTION PUMP PROTECTION

Perform 1 Month Time Injection Pump Protection concomitantly with the similar engine protection.

- a/ Remove right side plug and the frontal part bottom plug and drain oil.
- b/ Spray the interior of the frontal part with gasoline and then let gasoline leak.
- c/ Reinstall the frontal part bottom plug.
- d/ Spray the injection pump interior through the right side hole with MIL-L-6529 C Type 1 preservative oil grade heated to 50±70°C (122±158°F). Fill the pump interior with oil till to the brim of the right hole.
- e/ Crank engine approximately two rotations.
- f/ Drain protective oil through the pump frontal part bottom hole.
- g/ Reinstall both plugs.
- h/ Wrap the preserved injection pump with paraffin paper or plastic foil and secure with cord.

Note: *The foregoing protection can be repeated twice, concomitantly with the similar repeated engine preservations.*

9. INJECTION PUMP PROTECTION FOR A PERIOD LONGER THAN 3 MONTHS

Perform Injection Pump Protection for a Period Longer than 3 Months concomitantly with the similar engine preservation in the same way as the 1 Month Time Injection Pump Protection followed by the fuel lines protection in compliance with the following procedure:

- a/ Loose nozzle fittings from the air manifold and disconnect the fuel returning line from injection pump.
- b/ Loose fuel connection fitting and inject fresh MIL-L 6529 C Type 1 protective oil grade heated to 50±70°C (122±158°F), at a pressure of 196 kPa (28.44 lbs./sq.in.) through the fuel inlet fitting into the fuel compartment.
- c/ Crank engine from propeller until the protective oil begins to leak at the loosen nozzle fittings and at the returning fuel fitting on the fuel compartment cover.

- d/ Following the internal protection and the draining of the protective oil in excess from pump case frontal part and fuel compartment, protect the fuel inlet fitting with paraffin paper or a plastic foil and secure with wire.
- e/ Wrap the entire injection pump in paraffin paper or plastic sheet and secure with cord.

Note: *It is permitted to repeat once again this protection after 6 months storage without engine starting, provided that the previous protection was removed.*

10. INJECTION PUMP PREPARATION PRIOR TO NEWLY PUTTING AIRCRAFT INTO SERVICE

A. Preparation procedure for injection pumps, which underwent a 1 Month Time Protection:

- 1/ Remove plug from the right side of the pump.
- 2/ Fill the interior with engine oil grade in compliance with the specification in SECTION 4, until the brim of the hole.
- 3/ Reinstall plug at the pump right side.

B. Preparation procedure for injection pumps, which underwent a Protection for a Period Longer than Three Months:

- 1/ Prepare the injection pump in accordance with the procedure under A/.
- 2/ Disconnect the injection lines from nozzles on air intake elbows.
- 3/ Connect the line from fuel tank to the injection pump fuel inlet fitting.
- 4/ Crank engine from propeller until fuel appears at the injection line ends.
- 5/ Connect fuel injection lines to nozzles.

Attention: *All protections and associated repetitions must be entered to the injection pump attest under the date of performance and signature of the performing employee.*

SECTION 11

TABLES

1/ Centigrade – Fahrenheit Conversion 11-2

2/ Inch Fraction - Millimeter Conversion 11-3

3/ Conversion Factors 11-4

1. CENTIGRADE-FAHRENHEIT CONVERSION

Example: To convert 20°C to Fahrenheit, find 20 in the center column headed °F-°C, then read 68.0°F in the column °F to the right.

To convert 20°F to Centigrade, find 20 in the center column and read -6.67°C in the °C column to the left.

°C	°F-°C	°F	°C	°F-°C	°F
-56,70	-70	-94,0	104,44	220	428,0
-51,10	-60	-76,0	110,00	230	446,0
-45,60	-50	-58,0	115,56	240	464,0
-40,00	-40	-40,0	121,11	250	482,0
-34,00	-30	-22,0	126,67	260	500,0
-28,90	-20	-4,0	132,22	270	518,0
-23,30	-10	14,0	137,78	280	536,0
-17,80	0	32,0	143,33	290	554,0
-12,22	10	50,0	148,89	300	572,0
-6,67	20	68,0	154,44	310	590,0
-1,11	30	86,0	160,00	320	608,0
4,44	40	104,0	165,56	330	626,0
10,00	50	122,0	171,11	340	644,0
15,56	60	140,0	176,67	350	662,0
21,11	70	158,0	182,22	360	680,0
26,67	80	176,0	187,78	370	698,0
32,22	90	194,0	193,33	380	716,0
37,78	100	212,0	198,89	390	734,0
43,33	110	230,0	204,44	400	752,0
48,89	120	248,0	210,00	410	770,0
54,44	130	266,0	215,56	420	788,0
60,00	140	284,0	221,11	430	806,0
65,56	150	302,0	226,67	440	824,0
71,00	160	320,0	232,22	450	842,0
76,67	170	338,0	237,70	460	860,0
82,22	180	356,0	243,33	470	878,0
87,78	190	374,0	248,89	480	896,0
93,33	200	392,0	254,44	490	914,0
98,89	210	410,0	260,00	500	932,0

2. INCH FRACTION-MILLIMETER CONVERSIONS

Inch Fraction	Decimal Equiv.	Area Sq. In.	MM Equiv.	Inch Fraction	Decimal Equiv.	Area Sq. In.	MM Equiv.
1/64	0,0156	0,0002	0,397	1/2	0,5000	0,1964	12,700
1/32	0,0312	0,0008	0,794	17/32	0,5312	0,2217	13,494
3/64	0,0469	0,0017	1,191	35/64	0,5469	0,2349	13,891
1/16	0,0625	0,0031	1,587	9/16	0,5625	0,2485	14,288
3/32	0,0937	0,0069	2,381	19/32	0,5937	0,2769	15,081
7/64	0,1094	0,0094	2,778	39/64	0,6094	0,2916	15,478
1/8	0,1250	0,0123	3,175	5/8	0,6250	0,3068	15,875
5/32	0,1562	0,0192	3,969	21/32	0,6562	0,3382	16,669
11/64	0,17119	0,0232	4,366	43/64	0,6719	0,3545	17,065
3/16	0,1875	0,0276	4,762	11/16	0,6875	0,3712	17,462
7/32	0,2187	0,0376	5,556	23/32	0,7187	0,4057	18,256
15/64	0,2344	0,0431	5,593	47/64	0,7344	0,4235	18,653
1/4	0,2500	0,0491	6,350	3/4	0,7500	0,4418	19,050
9/32	0,2812	0,0621	7,144	25/32	0,7812	0,4794	19,844
19/64	0,2969	0,0692	7,540	51/64	0,7969	0,4987	20,241
5/16	0,3125	0,0767	7,937	13/64	0,8125	0,5185	20,637
11/32	0,3437	0,0928	8,731	27/32	0,8437	0,5591	21,431
23/64	0,3594	0,1014	9,128	55/64	0,8594	0,5800	21,828
3/8	0,3750	0,1105	9,525	7/8	0,8750	0,6013	22,225
13/32	0,4062	0,1296	10,319	29/32	0,9062	0,6450	23,019
27/64	0,4219	0,1398	10,716	59/64	0,9219	0,6675	23,416
7/16	0,4375	0,1503	11,112	15/16	0,9375	0,6903	23,812
15/32	0,4687	0,1725	11,906	31/32	0,9687	0,7371	24,606
31/64	0,4844	0,1842	12,303	63/64	0,9844	0,7610	25,003

3. CONVERSIONS FACTORS FROM ANGLO-SAXON TO METRIC UNITS

inch	mm	lb/sq.ft	kg/m ²
0,03937 --- 1 ---	25,4	0,2048 --- 1 ---	4,8826
ft	m	in.lb	kpm
3,2808 --- 1 ---	0,3048	86,7947 --- 1 ---	0,01152
naut.mile	km	in.lb	Nm
0,539 --- 1 ---	1,8532	8,85 --- 1 ---	0,113
mile(Brit)	km	ft/min	m/s
0,6214 --- 1 ---	1,6093	196,85 --- 1 ---	0,00508
sq.in	cm ²	knot	km/h
6,452 --- 1 ---	0,156	0,5397 --- 1 ---	1,8532
sq.ft	m ²	HP	kW
10,7643 --- 1 ---	0,929	1,34 --- 1 ---	0,746
cubic inch	litre	k	kW
61,0237 --- 1 ---	0,01639	1,36 --- 1 ---	0,7355
US gallons	litre	HP	k
0,2642 --- 1 ---	3,785	0,986 --- 1 ---	1,014
US quart	litre	lb/HP	kg/kW
1,0568 --- 1 ---	0,9463	1,645 --- 1 ---	0,6079
ml/US gallon	% volume	lb/HP	kg/k
37,85 --- 1 ---	0,0264	2,2355 --- 1 ---	0,4473
gallon(imp)	litre	BTU	kJ
0,220 --- 1 ---	4,546	0,9482 --- 1 ---	1,0546
quart(imp)	litre	BTU/sq.ft	J/cm ²
0,055 --- 1 ---	1,137	0,881 --- 1 ---	1,135
lb	kg	PSI	kPa
2,2046 --- 1 ---	0,4536	0,145 --- 1 ---	6,897
kp/cm ²	kPa	PSI	kp/cm ²
0,010197 --- 1 ---	98,0665	14,225 --- 1 ---	0,0703
inHg	kp/cm ²	°F=1,8°C+32 °C=5/9(°F-32)	
28,96 --- 1 ---	0,03453		