

BICYCLE GUIDE LINES

For dimensions
ref. Vo/4
page
12.1.2
to
12.1.7

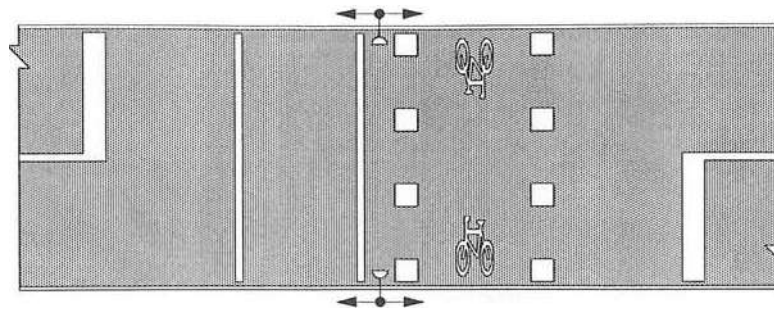

COLOUR:

White

GM5

7.4.5 Bicycle Guide Lines

- 1 BICYCLE GUIDE LINES guidance marking GM5 is **a transverse marking which may be used to indicate to road users the section of roadway to be used by cyclists to cross the roadway.**
- 2 BICYCLE GUIDE LINES shall comprise a pair of broken white lines with a minimum width of 300 mm and a line-to-gap ratio of 1 to 3 using dimensions of 300 mm and 900 mm. For the normal application of this marking the pairs of lines shall be spaced at least 1,5 m apart.
- 3 Bicycle crossings may require to be marked when an exclusive bicycle path, or shared bicycle/pedestrian path, crosses a roadway, normally in a mid-block situation, OR where a bicycle lane running parallel to one roadway crosses an intersecting side road (see Sub-section 7.2.13).
- 4 Bicycle crossings will frequently be adjacent to pedestrian crossings. In such situations, if space is limited, one BICYCLE GUIDE LINE of the marking may be omitted and that side of the bicycle crossing may be defined by the PEDESTRIAN CROSSING LINES marking RTM3, or BLOCK PEDESTRIAN CROSSING marking RTM4. If there is insufficient space for two separate crossings a pedestrian crossing should be marked and both pedestrians and cyclists directed to use it.

Reproduced under Government Printers Authorization No. 100/2017, dated 27 July 2017

ROAD MARKING SYMBOLS

COLOUR:

White

For dimensions
ref. Vol 4
pages
12.4.2
to
12.4.5

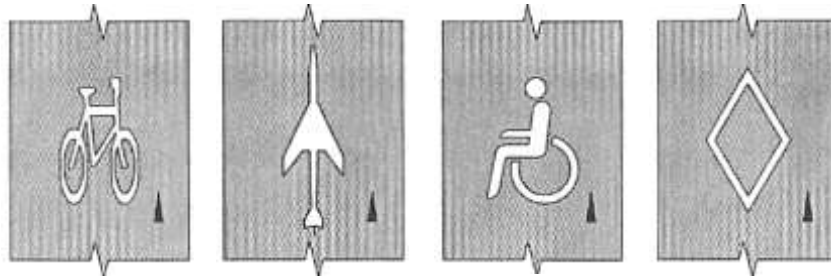

GM6.1

GM6.2

GM6.3

GM6.4

GM6

7.4.6 Road Marking Symbols

- 1 ROAD MARKING SYMBOLS may be used **to guide road users as an additional form of marking to standard signs and markings**. Approved ROAD MARKING SYMBOLS are:
 - (a) white BICYCLE SYMBOL marking GM6.1 shall be used at bicycle crossings in conjunction with BICYCLE GUIDE LINES marking GM5;
 - (b) white AIRPORT SYMBOL marking GM6.2 which may be used within a lane or portion of roadway to give directional guidance indicating that the lane so marked leads to an airport;
 - (c) white DISABLED PERSONS SYMBOL marking GM6.3 which may be used to indicate areas set aside for use by disabled persons;
 - (d) white HIGH OCCUPANCY VEHICLE (HOV) SYMBOL marking GM6.4 which may be used to give guidance to drivers of HOV vehicles other than with marking RM9.
- 2 ROAD MARKING SYMBOLS shall comprise white symbolic markings with a length generally in accordance with Table 7.1. If a ROAD MARKING SYMBOL is being developed for use under free-flowing traffic conditions the length relationship between the symbol and a normal pictogram of the subject should involve a lengthwise elongation of the order of three times or more. The marking should be sized to be fully contained within a lane.
- 3 If a suitable symbolic message is available it should be used in preference to a WORD marking GM7.
- 4 Care should be taken in the use of symbols with large surface areas that a potential skidding hazard is not being created for motor-cycles. Markings using materials with the best possible skid resistance characteristics should therefore be specified.

Only approved symbols shall be used.

WORD MARKINGS

For dimensions
ref. Vol 4
pages
12.5.1 to
12.5.9

COLOURS:

White

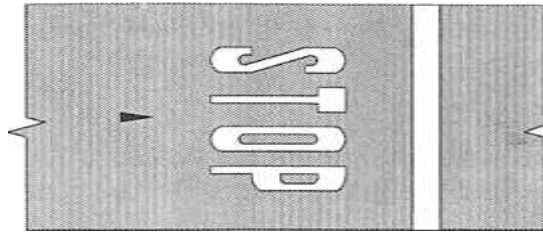

GM7

7.4.7 Word Markings

- 1 WORD MARKINGS are guidance markings GM7 which may be used **when it is absolutely necessary to give additional guidance to road users**. An appropriate, approved, ROAD MARKING SYMBOL shall always be used in preference to a word message.
- 2 WORD MARKINGS shall comprise white letters and/or numerals. The letter height should be in accordance with the provisions of Table 7.1. It should be noted that the long-standing letter height of 5,5 m, used on rural roads, has been retained instead of converting to the 5 m used for many other markings.
- 3 In situations where lane selection is critical, and guidance signing opportunities are limited, guidance word

messages consisting of route numbers or abbreviated destination names e.g. "JHB" or "DBN" may be used to advantage. The use of route numbers is recommended in preference to abbreviations.

- 4 The amount of WORD MARKINGS used at any one point should be limited to reduce the risk of creating a skid hazard. The message should be as concise as possible. If a multi-word message (two or three words) is used the first word in the message should be marked on the road surface first, followed by subsequent words at spacings of one to two times the marking height apart.

KERBFACE MARKING

For dimensions
ref. Vol 4
page
12.1.2
to
12.1.7

COLOURS:

Black and
white



GM8

7.4.8 Kerbface Marking

- 1 KERBFACE guidance marking GM8 may be used to indicate to road users **the presence of kerbing on the kerb line of a roadway**. Use of the marking is OPTIONAL.
- 2 In terms of practical economic, aesthetic and design considerations it **is not required nor recommended that all kerbing be marked with KERBFACE marking GM8**.
- 3 KERBFACE marking GM8 shall comprise alternating sections of black and white painted kerbing. The lengths of the black and white sections should be equal, and in the range of 600 mm to 1 000 mm.

- 4 KERBFACE marking GM8 can be used to improve conspicuity and therefore the visual impact of a section of kerbing which has been placed to a greater or lesser degree in the path of on-coming traffic (the marking of kerbing within dual carriageway junctions should be undertaken with care since it is possible for different sections of kerbing to blend into each other, possibly resulting in confusion as to the layout of the junction).
- 5 Experience has shown that the paint used on kerbfaces needs to be to a road marking paint specification for durability. To ensure the effectiveness of the marking under adverse conditions or at night it is recommended that retroreflective white paint be used.

7.5 ROADSTUDS

7.5.1 Introduction

- 1 ROADSTUDS may be used to supplement road markings more especially in situations where the road markings are subject to conditions of poor or limited visibility.
- 2 The greater height of a roadstud above the road surface and the incorporation of retroreflective lenses, which efficiently reflect vehicle headlamp beams over considerable distances, can improve the guidance normally given by road markings, under conditions where these become ineffective.
- 3 This section covers the manner in which roadstuds may be used and situations in which they are not recommended. Details are given of typical situations where the use of roadstuds may be beneficial. A road authority may, however, adopt a policy to use roadstuds universally on a particular class of road or on all roads within its jurisdiction.
- 4 It is recommended that only roadstuds which comply with the requirements of the South African Standard Specification SABS 1442-1987, *Roadstuds* or similar, be used.

7.5.2 Colour Coding

- 1 It is essential that the meaning imparted by roadstuds and the guidance given by them is consistent and predictable. Only three colours of roadstud may be used to supplement road markings. The meanings intended to be conveyed by these three colours, in conjunction with the relevant road markings are:

- (a) RED shall mean PROHIBITION;
- (b) YELLOW shall mean WARNING;
- (c) WHITE shall offer GUIDANCE.

- 2 The colours permitted, and their functions, are:

(a) RED:

- (i) to supplement any road marking to indicate potential "wrong-way" driving situations;
- (ii) in conjunction with a white NO CROSSING line marking RM2;
- (iii) in conjunction with a white RIGHT EDGE LINE marking RM4.2;
- (iv) in conjunction with a white NO OVERTAKING line marking RM1;

(b) YELLOW:

- (i) in conjunction with yellow road markings with the exception noted in sub-paragraph 7.5.2.2(a)(i);

(c) WHITE (or clear):

- (i) in conjunction with white road markings with the exception noted in sub-paragraph 7.5.2.2(a)(i).

- 3 Roadstuds may be omnidirectional, uni-directional or bi-directional. Omnidirectional class roadstuds are available in white (clear) and may be specified for white roadstud applications where a uni- or bi-directional requirement is not specifically required. Uni-directional roadstuds may be specified for use in white, yellow or red. Bi-directional roadstuds may be specified as:

- (a) white/white;

- (b) white/red;
- (c) yellow/yellow;
- (d) yellow/red;
- (e) red/red.

7.5.3 Uses of Roadstuds

- 1 It is recommended that ROADSTUDS be considered for use to supplement any of the following types of road marking when any of the conditions listed in paragraph 7.5.3.2 exist separately or in combination:

- (a) NO OVERTAKING LINE RM1;
- (b) NO CROSSING LINE RM2;
- (c) CHANNELISING LINE RM3;
- (d) LEFT EDGE LINE RM4.1;
- (e) RIGHT EDGE LINE RM4.2;
- (f) PAINTED ISLANDS RM5;
- (g) CONTINUITY LINE WM2;
- (h) DIVIDING LINE WM3;
- (i) REVERSIBLE LANE WM4;
- (j) ARRESTOR BED AHEAD WM9;
- (k) LANE LINE GM1.

- 2 When the following conditions occur either separately or in combination the use of roadstuds may be warranted:

- (a) regular occurrence of mist, fog or rain resulting in:
 - (i) significantly reduced visibility;
 - (ii) reduced performance of conventional road markings due to standing water;
- (b) heavy traffic volumes resulting in:
 - (i) poor visibility due to glare from the head lamps of oncoming vehicles;
 - (ii) restricted forward vision due to traffic density and resulting close following distances;
 - (iii) rapid wear of conventional road markings;
- (c) isolated low standard road design resulting from:
 - (i) changing vertical and/or horizontal alignment;
 - (ii) reduced carriageway width or lateral clearance to street furniture;
 - (iii) a speed limit set well below the general limit for the class of road, or an advisory speed displayed which is much lower (>20%) than the general speed limit;
 - (iv) poor surface water drainage;
- (d) hazardous sites, with documented accident records, involving:
 - (i) T-junctions;
 - (ii) wrong-way travel;
 - (iii) complex lane layouts;
 - (iv) sharp curves;
 - (v) at grade railway crossings;
- (e) roadworks sites of significant time duration to demarcate:
 - (i) temporary road alignments;

- (ii) temporary lane arrangements;
 - (iii) rapid lane indication after resurfacing;
 - (f) on all freeways (both Class A1 and Class A2).
- 3 The use of roadstuds is generally NOT recommended where:
- (a) cyclists may be affected;
 - (b) traffic speeds are low;
 - (c) street lighting is of a sufficient standard to ensure adequate night-time visibility;
 - (d) road resurfacing is planned in the near future;
 - (e) specifically across the exit point to freeway off-ramps and the entry point of freeway on-ramps and any other similar situation where traffic leaves or joins a major roadway in a free-flowing or merging manner.
- 4 The requirement in paragraph 7.5.3.3(e) will have the effect that roadstuds will not commonly be used with certain applications of CONTINUITY LINE marking WM2.

7.5.4 Temporary Roadstuds

- 1 Temporary roadstuds may be specified for use at major roadworks sites, particularly at temporary changes in road alignment.
- 2 A limited number of temporary roadstud designs have been produced which conform to the requirements that they should be inexpensive (therefore expendable and not re-used), and quick, easy and inexpensive to apply and reasonably durable in heavy traffic conditions.
- 3 A white or yellow temporary roadstud which can comply with these performance parameters may be considered for use at very close spacings to simulate a road marking line.

7.5.5 Longitudinal Spacing and Lateral Position

- 1 When roadstuds are specified for use they should be spaced longitudinally in accordance with the recommendations in Table 7.8. The descriptions "Normal", "Intermediate" and "Abnormal" given in Table 7.8 are general terms intended to offer a limited grading of the severity of conditions which may warrant the use of roadstuds with road markings. The actual level of severity of condition to which individual road authorities relate these terms is subject to their specific policies on the use of roadstuds.
- 2 In addition to the requirements of Table 7.8 roadstuds shall be spaced so that there are at no time fewer than three roadstuds visible to a driver to define each specific longitudinal line. This may result in a need to upgrade the spacing category from "Normal" to "Intermediate",

or "Intermediate" to "Abnormal".

- 3 On multi-lane roads all roadstuds on parallel longitudinal lines should be spaced to fall on common cross-sections. It is preferable to design the roadstud placement for complex areas first.
- 4 The spacings of multiple line markings such as NO OVERTAKING LINES RM1 with DIVIDING LINE WM3, and NO CROSSING LINES RM2, should be such that, if a roadstud is to be placed between two parallel lines, there should be a minimum of 150 mm between the lines to allow a minimum side clearance between line and roadstud of 25 mm.
- 5 Other roadstud applications with continuous lines require the roadstud to be placed to the side of a line using a preferred separation of 50 mm and a minimum separation of 25 mm. Wherever possible the roadstud should be placed on the side of a line outside the travelled way.
- 6 Where roadstuds are specified with the single continuous longitudinal line markings such as a CHANNELISING LINE RM3, or a single NO OVERTAKING LINE RM1, they should be placed on the road surface prior to marking. They may then be masked to avoid over-painting
- 7 When a longitudinal marking is more than 200mm wide it is recommended that two roadstuds of the appropriate colour be placed side by side and at recommended longitudinal spacings. It is also recommended that in such applications "Intermediate" or "Abnormal" spacings are used. Examples of such markings/double stud applications are 300 mm wide CHANNELISING LINES RM3 and EXTRA DENSITY CONTINUITY LINES WM2.
- 8 A limited range of roadstud and line road marking combinations is given in Figures 7.9 to 7.11. These figures show all roadstuds as bi-directional. Such a specification is optional in certain respects.

Uni-directional or Omnidirectional roadstuds may be specified as follows:

- (a) on a one-way roadway all roadstuds may be uni-directional;
- (b) on an undivided multi-lane roadway with more than three lanes the roadstuds used with lane line marking may be uni-directional or omnidirectional and those used with edge line markings may be uni-directional.

As a result of these options designers should check the policies of any authority for which they undertake work to determine the specific requirements of the authority.

A wider range of roadstud applications is covered in Volume 2, Chapter 2.

TABLE 7.8.

RECOMMENDED LONGITUDINAL ROADSTUD SPACING

TABLE 7.8.

	Normal (m - c/c)	Intermediate (m- c/c)	Abnormal (m - c/c)
Rural	24	12	6
Urban	18	9	3
Temporary	12	6	3 down to 1

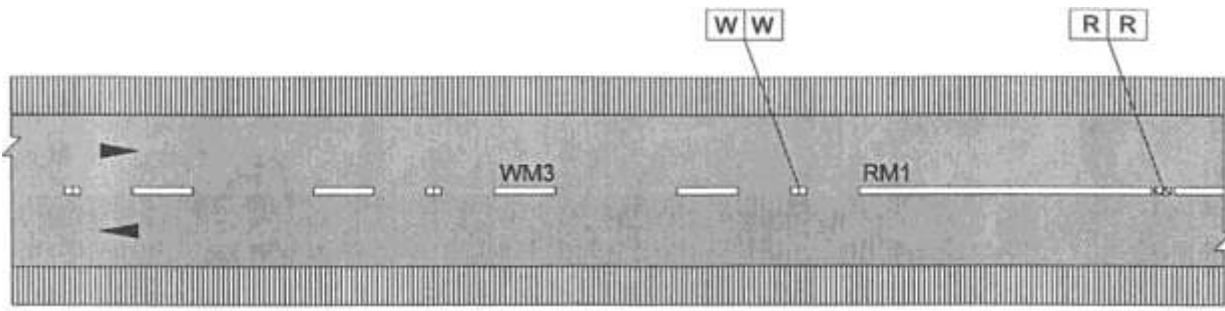

Detail 7.9.1 2 Lane/2 Way - No Surfaced Shoulders

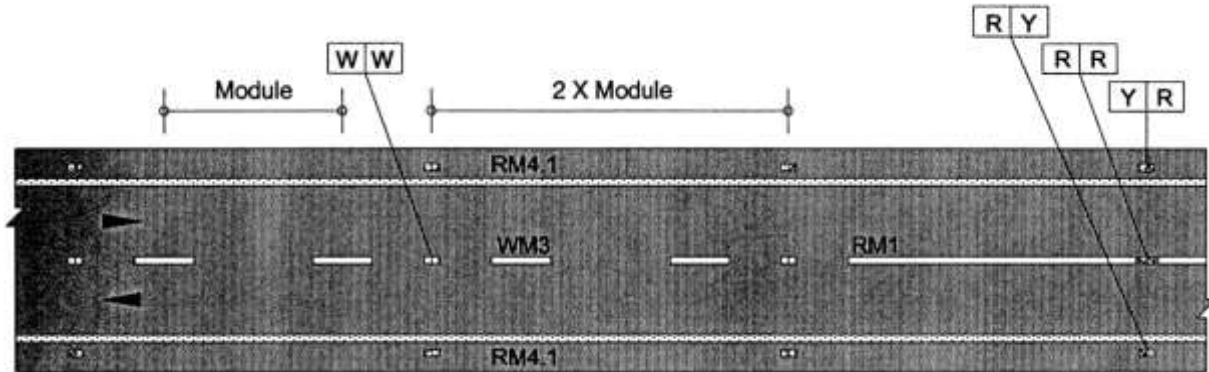

Detail 7.9.2 2 Lane/2 Way - With Surfaced Shoulders

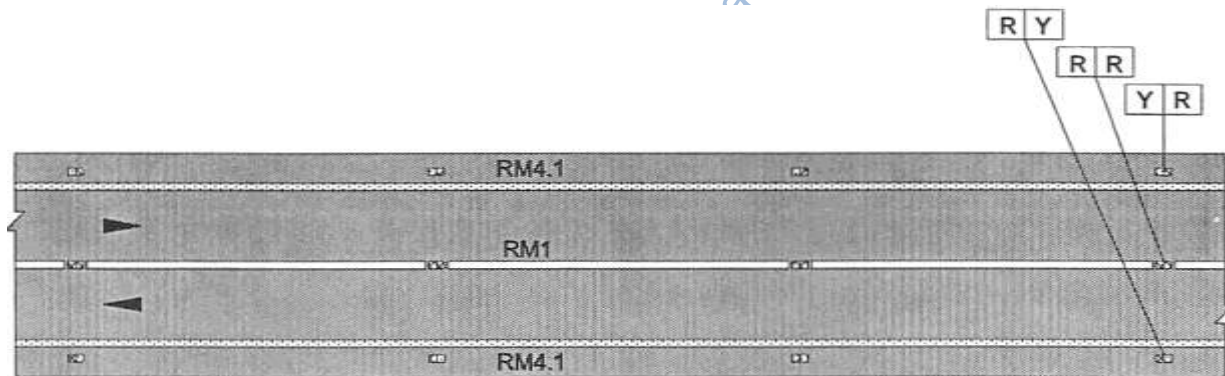

Detail 7.9.3 2 Lane/2 Way- No Overtaking Line

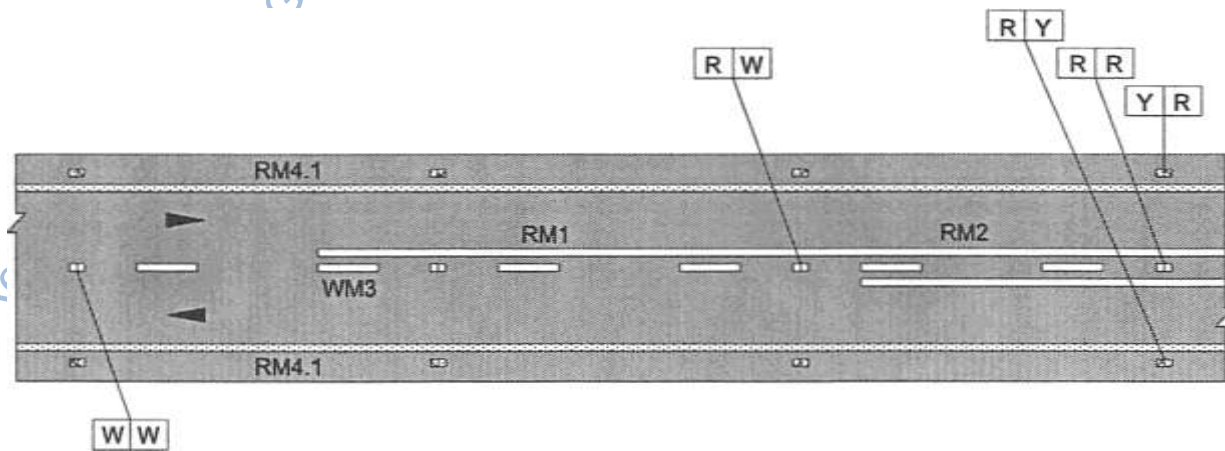

Detail 7.9.4 2 Lane/2 Way- No Overtaking/No Crossing Lines

Fig. 7.9 Typical Roadstud Use on Two-way Roadways

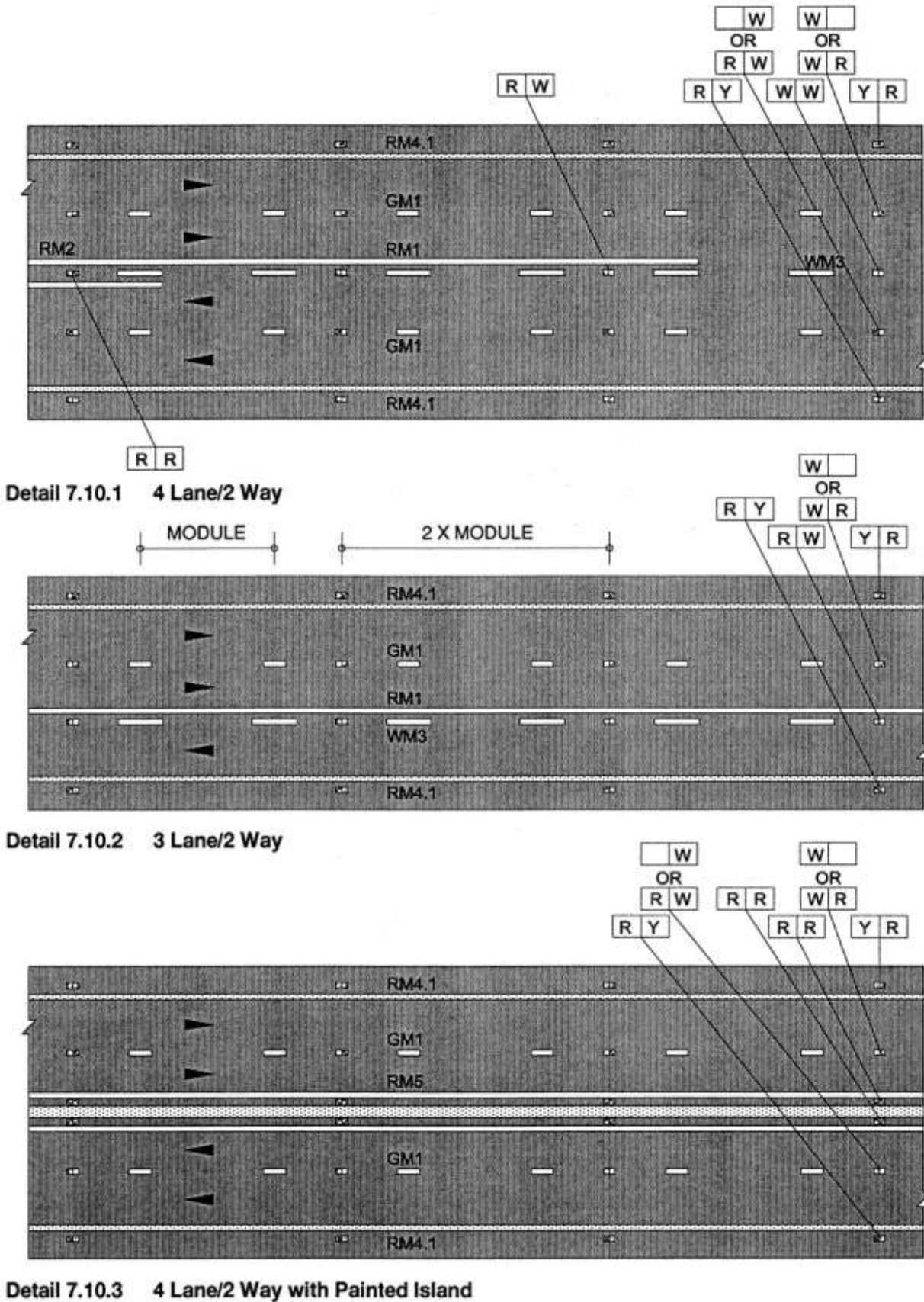
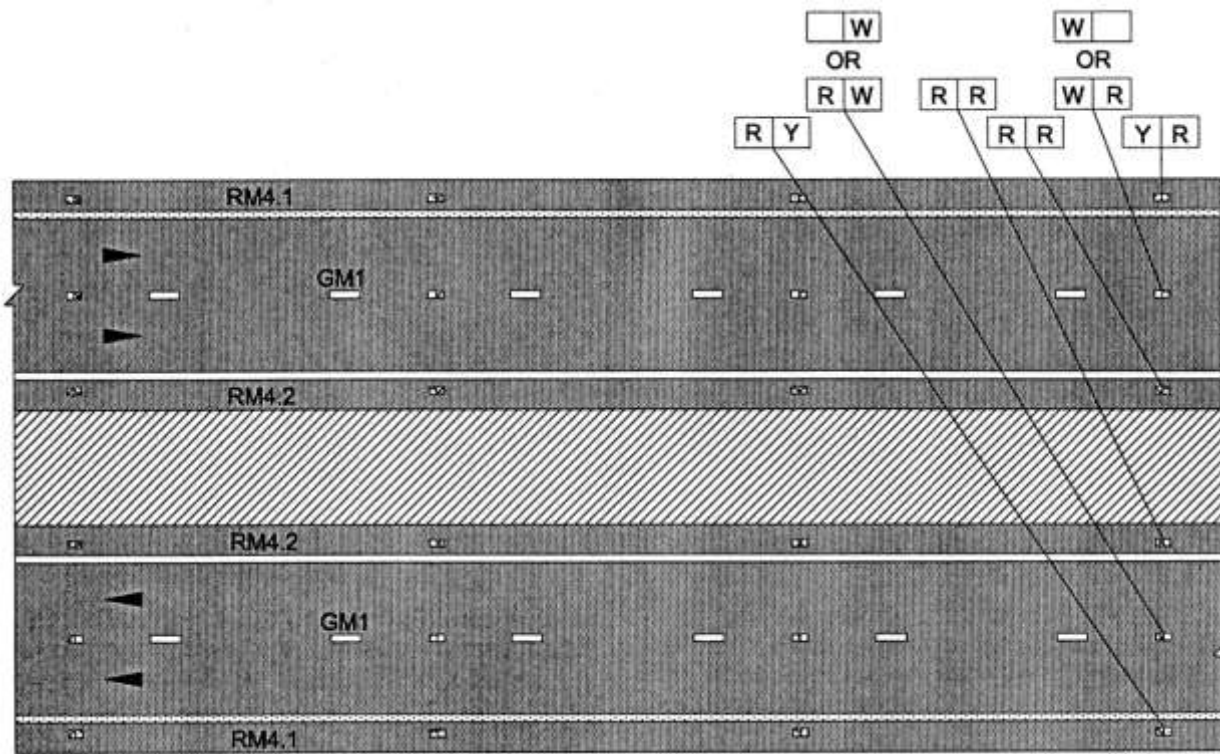
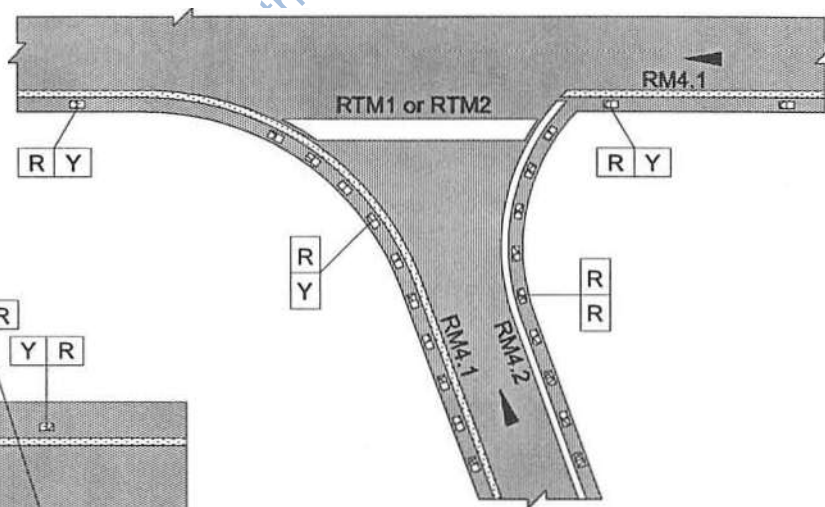

Fig.7.10 Typical Roadstud Use on 2 Way Multiple-Lane Roadways with Dividing Lines



Detail 7.11.1 Typical Cross-Section Layout



Detail 7.11.2 Treatment at Off-Ramp Terminal Junction

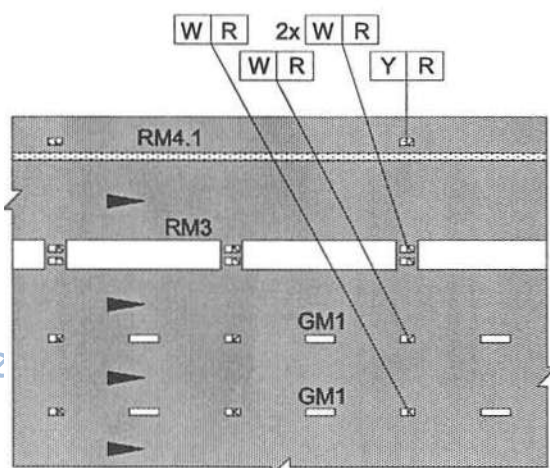

Detail 7.11.3 Treatment at Dedicated Exit Lane (Channelising Line over 200 mm Wide)

Fig.7.11 Typical Roadstud Use on Freeway Carriageways

GUARDRAIL DELINEATORS

COLOURS:

PERMANENT

Red retroreflective on
white retroreflective

TEMPORARY

Black semi-matt on yellow
retroreflective

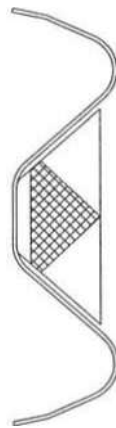

D1



Reverse side



Both sides

TD1

For dimensions
ref. Vol 4
page
12.6.1

7.6.1 Guardrail Delineators

- 1 GUARDRAIL DELINEATORS D1 are retroreflective devices used **to warn road users of a barrier guardrail** (see Chapter 10 for the definition of a barrier).
- 2 GUARDRAIL DELINEATORS shall be attached securely to W-section, or similar, barriers within the recessed section at a maximum spacing of four standard 7.62 m guardrail sections. The retroreflective area of each face shall be a maximum of 70 cm². The use of higher than Class 1 grade retroreflective material may be considered, particularly in areas subject to regular poor visibility conditions.
- 3 The "wrong" side of all permanent GUARDRAIL DELINEATORS shall be covered with red retroreflective material to discourage the possibility of wrong-way travel (see Subsection 7.5.2).
- 4 Temporary GUARDRAIL DELINEATORS TD1 shall be double-sided and black and yellow in colour. The maximum spacing shall be reduced to two standard 7.62 m guardrail sections.
- 5 A barricade which is not capable of withstanding vehicle impact, but which may have the general appearance of a barrier, shall be provided with GUARDRAIL DELINEATORS D1 or TD1.
- 6 If a concrete "New Jersey" style barrier is to be used, either temporarily or permanently, it is recommended that such barriers be provided with GUARDRAIL DELINEATORS D1 or TD1. A recess capable of wholly containing the delineator within the vertical projection of the lower edge of the barrier should be provided.

Reproduced under Government Printer's Authorization No. 1512 dated 7th July 2011

FLOOD or SNOW DELINEATORS

For dimensions
ref. Vol4
Not Applicable

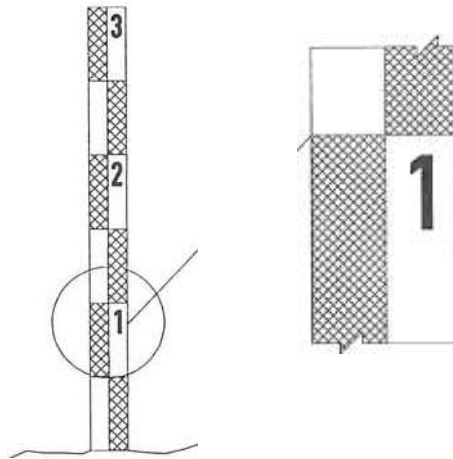

D2

COLOURS*

Red and white
retroreflective
with black semi-
matt numerals

7.6.2 Flood or Snow Delineators

- 1 FLOOD or SNOW DELINEATORSb2 are retroreflective devices used **to warn drivers that the road ahead is submerged by floodwater or snow drifts to an extent that it may be hazardous for drivers to proceed.**
- 2 FLOOD or SNOW DELINEATORS may comprise a vertical post with a minimum width of flat surface of 150 mm facing traffic in both directions. The flat surface may be covered in red and white retroreflective materials in a chequer-board pattern of 500 mm intervals. The height of the delineator should be a minimum of 3 m, and each metre should be marked in a white panel by a black semi-matt numeral.
- 3 Use of FLOOD or SNOW DELINEATORS is particularly appropriate to long shallow valleys where

a high level bridge has not been provided and where, in the event of flooding, the extent of the flooding may be difficult to judge. The delineator devices may also be useful in mountain passes to indicate the extent of snow falls and the alignment of the roadway ahead.

- 4 FLOOD or SNOW DELINEATORS should be spaced approximately 50 m to 200 m apart, on both sides of the roadway, located outside the shoulder break point. They should be placed so that the vertical and horizontal profile of the road is accurately delineated. They should be well founded to resist water flow but in such a way that if the roadway is washed away they will also fail.

SHOULDER DELINEATORS

For dimensions
ref. Vol4
Not Applicable



D3

COLOURS*

Black and white
or natural colour
with yellow
retroreflective
panel(s)

7.6.3 Shoulder Delineators

- 1 SHOULDER DELINEATORS D3 are devices used **to indicate to drivers the alignment of roads, and in particular the limits of gravel shoulders around curves.**
- 2 There is no prescribed shape or size for such devices. It is recommended that they be light in colour. A minimum area of 800 cm² facing in each direction is recommended, with a recess in each side in which yellow retroreflective material with a minimum area of 50 cm² may be placed
- 3 Spacings of 50 m on curves between 300 m and 100 m radius, and 100 m on straights and curves over 1 000 m radius are recommended. If smaller radius

curves are used spacings should be reduced to those given in Table 3.5 for signs W405 and W406 (see Subsection 3.5.3).

- 4 SHOULDER DELINEATORS should be located on both sides of the roadway 0,3 m outside the shoulder break-point.
- 5 Distances or road maintenance information may be included on such devices.
- 6 SHOULDER DELINEATORS are not a substitute for DANGER PLATES W401 or W402, or SHARP CURVE CHEVRONS W405 or W406. If either of these types of hazard markers are used then shoulder delineators become superfluous.

TRAFFIC CONES

COLOURS:

Red-orange with white
or yellow retroreflective
sleeve

For dimensions
ref. Vo/4
Not Applicable



TD4

7.6.4 Traffic Cones

- 1 TRAFFIC CONES TD4 are portable temporary devices used **to indicate to drivers a temporary shift in alignment around a localised work area, an accident site or a roadblock.**
- 2 TRAFFIC CONES shall have a minimum height of 450 mm in urban areas and 600 mm on high speed roads. A height of 750 mm or more is preferred for all longer term high speed road applications other than when used by accident response units.
- 3 TRAFFIC CONES should not be used for applications lasting more than 8-10 hours and preferably not on an overnight basis. DELINEATOR PLATES IW401 and IW402, should be used for applications lasting more than 8-10 hours and/or overnight.
- 4 If traffic cones are used for short periods at night-time they should have at least half of the cone surface covered with a white or yellow retroreflective material. This may be achieved by the use of removable sleeves of retroreflective material. The normal colour for TRAFFIC

CONES is a fluorescent red-orange. However, under certain types of street lighting, an all yellow or white cone can be more effective. A light road surface colour may require that the base of a white cone is black or some other dark contrasting colour.

- 5 The cone base should be NON-CIRCULAR for stability. The cone design should be such that the weight in the base prevents them from being blown over by passing vehicles. Recommended nominal base diameters are 250 mm (for 450 mm height) and 400 mm (for 750 mm height) with proportional dimensions for other sizes.
- 6 Since traffic cones are intended to be used for easy and rapid deployment they should be stackable for compact storage but still be designed for easy separation.
- 7 Traffic cones should never be placed on the roadway without appropriate advance temporary signs. Cones should be under constant supervision so that if knocked over or moved they can be replaced in their correct position.

7.7 NATIONAL VARIANTS

7.7.1 General

- 1 Whilst the objective of the SADC Road Traffic Sign System is to achieve the highest possible degree of harmonization of the system throughout the region it is likely that there will be a number of details which will remain unique to individual member countries.
- 2 For the purposes of identification any such road markings are considered as NATIONAL VARIANTS specific to one or more of the SADC member countries. Variants can occur in one of three ways, namely:
 - (a) as an ADDITIONAL variant using a modified or different symbol for a road marking function used in most member countries; or
 - (b) as a UNIQUE variant where the road marking is used in only one country; or
 - (c) as an ADDITIONAL variant to accommodate the language of a SADC member country which does not have English as an official language (at the time of publishing such variations apply to the use of Portuguese in Angola and Mozambique, although every effort has been made to minimise this need by the use of symbolic messages).
- 3 All road markings are listed once in colour in the Contents section and are provided with text describing their meaning and function. Any additional National variants involving a modified or different symbol will be identified pictorially in the National Variants section. Any National Variants which are unique to one country will appear in the National Variants section complete with appropriate text.
- 4 All road markings are allocated numbers. An additional variant is allocated a three letter suffix identifying the country to which it belongs. In the case of a unique variant such a road marking will be allocated a unique number which includes the appropriate National three letter suffix. If the road marking becomes more widely used the use of the suffix will be discontinued. The letter codes allocated for each member country are as follows.

(a) Angola	Ang;
(b) Botswana	Bot;
(c) Democratic Republic of Congo	DRC;
(d) Lesotho	Les;
(e) Malawi	Mal;

- | | |
|------------------|------|
| (f) Mauritius | Mau; |
| (g) Mozambique | Moz; |
| (h) Namibia | Nam; |
| (i) Seychelles | Sey; |
| (j) South Africa | RSA; |
| (k) Swaziland | Sw; |
| (l) Tanzania | Tan; |
| (m) Zambia | Zam; |
| (n) Zimbabwe | Zim. |

5 When National Variants occur they will be covered in Subsections of this Section, bearing the name of the country. All National Variants are identified in the Contents by a black dot thus - ●. The purpose in identifying variants is to assist education on road traffic signs within the region for travellers beyond National borders, and to assist road marking contractors and road authorities.

- 6 Road markings are much more generic than road signs and there are very limited requirements for National Variants.

7.7.2 Angola

- 1 Due to the fact that traffic travels on the right side of the roadway in Angola certain road markings are used in what amounts to a mirror image application of those used in other member countries. Most of these, such as STOP LINE marking RTM1, and YIELD LINE marking RTM2, are so obvious that they are not identified here as specific National Variants.
- 2 Two specific markings are illustrated in Figure 7.23 to ensure their correct application. These markings are:
 - (a) PAINTED ISLAND regulatory marking RM5-Ang;
 - (b) TRAFFIC CIRCLE MANDATORY DIRECTION ARROWS regulatory marking RM15-Ang.

These two markings are in fact also mirror images of the markings illustrated in Section 7.0 but are shown in Figure 7.23 because of their particular safety aspects with regard to direction of travel.

7.7.3 Angola and Mozambique

- 1 Since English is not an official language in Angola and Mozambique the application of Portuguese WORD MARKING guidance markings GMB is likely.

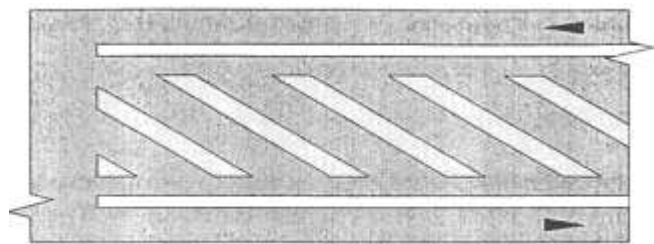
**RM5-Ang**

Refer: 7.2.9 page 7.2.15

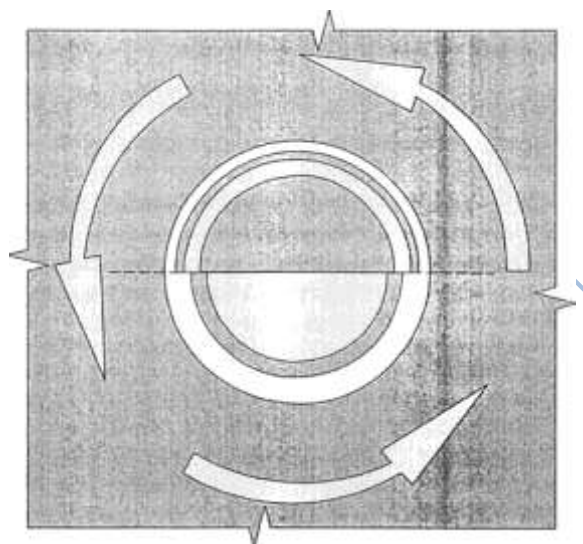
**RM15-Ang**

Refer: 7.2.19 page 7.2.29

Fig 7.12**Road Markings with Reversed Elements - ANGOLA**

Reproduced under Government Printers Authorization No. 11542/10



SOUTHERN
AFRICAN
DEVELOPMENT
COMMUNITY

NAVIGATIONAL AIDS

SECTIONS

- 8.1 Introduction
- 8.2 Types of Navigational Aids
- 8.3 Route Optimisation
- 8.4 Route Numbering
- 8.5 Selection of Destinations
- 8.6 National Variants

MAY 2012



SADC RTSM - VOL1

CHAPTER

8

CHAPTER 8: NAVIGATIONAL AIDS

8.1 INTRODUCTION

8.1.1 General

- 1 As the complexity of a road network increases the variety of routes leading through junctions and interchanges may create alternative routes by which drivers may reach a destination. Drivers therefore need navigational information to enable an optimum route to be chosen, followed, or adopted when required by local conditions, until their destination is reached. For the majority of drivers and trips, this navigational information is personal knowledge based on experience. Strangers who do not know a route or area should, however, acquire all or most of their navigational information as a result of PRE-TRIP PLAN-NING.
- 2 Once on the road, drivers should be guided through- out the trip by appropriate messages, which are consistent with their expectations, and which enable them to reach their required destinations, with a minimum of disruption to themselves and to other traffic. Since a tourist has been defined elsewhere as any person undertaking temporary, short term trips to destinations outside the place where they normally live and work, it can be interpreted that the driver referred to in the text is a tourist.
- 3 This Chapter therefore gives guidelines, designed to help the responsible rural and metropolitan road authorities develop a uniform approach on navigational aids for the road users, as part of the Motorist (Road user) Information System. Municipal road authorities shall consult with other relevant local authorities and with the national and other road authorities to ensure that continuity of destination signage through their areas is achieved.

8.1.2 Assumptions

- 1 In order to develop this uniform approach a number of assumptions relating to the navigational process have to be made. These assumptions are:
 - (a) that drivers have a general knowledge of the relative locations of FAMILIAR destinations;
 - (b) that **maps and route numbers** form the **primary information system** on routes on which the majority of trips occur, whether these are work, business, pleasure or directly related to tourism;
 - (c) that **guidance signs** play an essential **supporting role** to the primary information system;
 - (d) that direction signs and the destinations displayed on them, and interchange **exit** numbers should be designed on the basis that drivers **do use maps, and plan their trips when these are to areas with which they are not familiar.**
- 2 Although these assumptions are made in order to place practical limits on the scale of navigational information given to drivers, they shall be applied with circumspection. In some cases one or more of the assumptions may clearly not be appropriate, and extra steps should be taken to ensure that adequate navigational information is available. Such steps may typically result in the use, for instance, of supplementary guidance signs in the form of TOURISM

signs to assist foreign visitors, who may lack even basic local knowledge.

8.1.3 The Road Network

- 1 The road network comprises a number of components which can be classified in a hierarchical manner. The principal components are the LINKS or **connecting routes**, and the NODES or **destinations**. In order for drivers to travel along a LINK towards the NODE of their choice they require some form of ORIENTATION at the point of entry to the LINK (often another NODE). Orientation is thus a function or property of a NODE or destination.
- 2 A systematic approach to providing the necessary navigational information, requires that these components be classified into hierarchies. Each SADC member state has its own road network (see Figure 8.2), and numbered SADC routes have been identified which are superimposed on the individual national networks without affecting these. The SADC numbered route network is shown in Figure 8.1.

8.1.4 Link or Route Classification

- 1 Regardless of the status of the authority responsible for a particular route, links or routes may be classified as follows :
 - (a) INTER-STATE routes- numbered major inter-national routes;
 - (b) PRIMARY or TRUNK routes - numbered major inter-provincial or national links;
 - (c) SECONDARY or ARTERIAL routes - numbered minor inter-provincial or major inter-regional or intra-regional links;
 - (d) TERTIARY or REGIONAL routes - numbered minor inter-regional or major intra-regional links;
 - (e) ACCESS routes - direct access links to local destinations;
 - (f) METROPOLITAN routes- numbered intra-metropolitan links.
- 2 INTER-STATE, PRIMARY, SECONDARY and TERTIARY routes are primarily rural routes but they can start in metropolitan or major urban areas and will commonly traverse these types of areas as well. Rural ACCESS routes can be de- fined simply as in paragraph 8.1.4.1(e). In urban areas their route access function is more difficult to define as a wider range of route types is covered. Urban ACCESS routes, as a group, may include collector-distributor roads which may be classified lower than urban Class "B" roads. (i.e. ACCESS routes are not numbered routes.) They may also include direct access roads which have a similar function to their rural counterparts. Since collector-distributor roads, by definition, may serve several local destinations the choice of ORI- ENTATION points, which will commonly be suburb names, will become difficult at this level. Whilst METROPOLITAN routes, as defined in paragraph 8.1.4.1(f), will commonly lie wholly within a metropolitan area, when such areas

about each other the METROPOLITAN route numbering system may extend across common boundaries.

- 3 For details of route numbering refer to Section 8.4.
- 4 Road classification is discussed in Chapter 1, Section 1.2 in a general way, and in Chapter 4, Section 4.5 with regard to urban roads.

8.1.5 Node or Destination Classification

- 1 Nodes or destinations are selected by way of a methodology described in Section 8.S, and are then classified into the following :
 - (a) FAMILIAR destinations - those orientation points which are assumed to be known to virtually all drivers, including foreign visitors, in terms of the general direction required to be taken to reach them, and the approximate distance to be covered in order to reach them;
 - (b) CONTROL destinations - are orientation points which offer drivers *en route* checks or verifications as to their position or progress;
 - (c) SERVICE destinations- are points on routes where road users would expect to be able to obtain various services such as vehicle service, food and accommodation.

- 2 Destinations names for use on primary signs are selected from the FAMILIAR and CONTROL levels. SERVICE destinations appear on the confirmation signs together with CONTROL destinations (and/or FAMILIAR destinations in certain cases).

8.1.6 Orientation Point Classification

- 1 From a study of International and National maps, the locations of major orientational centres of attraction should be identified. In effect the selection is based on the likelihood of a tourist being able to identify with such orientation points. For the purposes of classification the attraction or orientational value of destinations may be described by a number of "Levels". Up to six levels may be considered and the parameters for these levels should be based on various characteristics of candidate towns (see Subsection 8.3.2). Member countries may have appropriate listings of local authorities which can serve as a basis for ORIENTATION POINT classification.
- 2 The classification of orientation points should be related to the class of LINK on which they occur and to their NODE classification. The relationship between NODES, LINKS and ORIENTATION POINTS is given in Table 8.1.

TABLE 8.1 Nodes (Destinations)	ORIENTATION POINTS					TABLE 8.1 Metropolitan
	Inter-State	Primary	Secondary	Tertiary	Access	
Familiar		Level 1	Level 2	Level 3	Level 4	Metro Level A
Control		Level 2	Level 3	Level 4	Level 5	Metro Level B
Service		Level 3	Level 4	Level 5	Level 6	Metro Level C
		Level 4	Level 5	Level 6		Metro Level D
		Level 5	Level 6			Metro Level E
		Level 6				

NOTES:

(1) Generally only FAMILIAR and CONTROL Nodes should appear on direction signs. SERVICE nodes should be included on confirmation signs, except in cases where destination signs will logically require the inclusion of these.

(2) Border posts should be listed as a unique Orientation Level. They may be elevated to Level 2 status for direction sign purposes.

(3) This table is used to determine the basic destination classification (see 8.S.3).

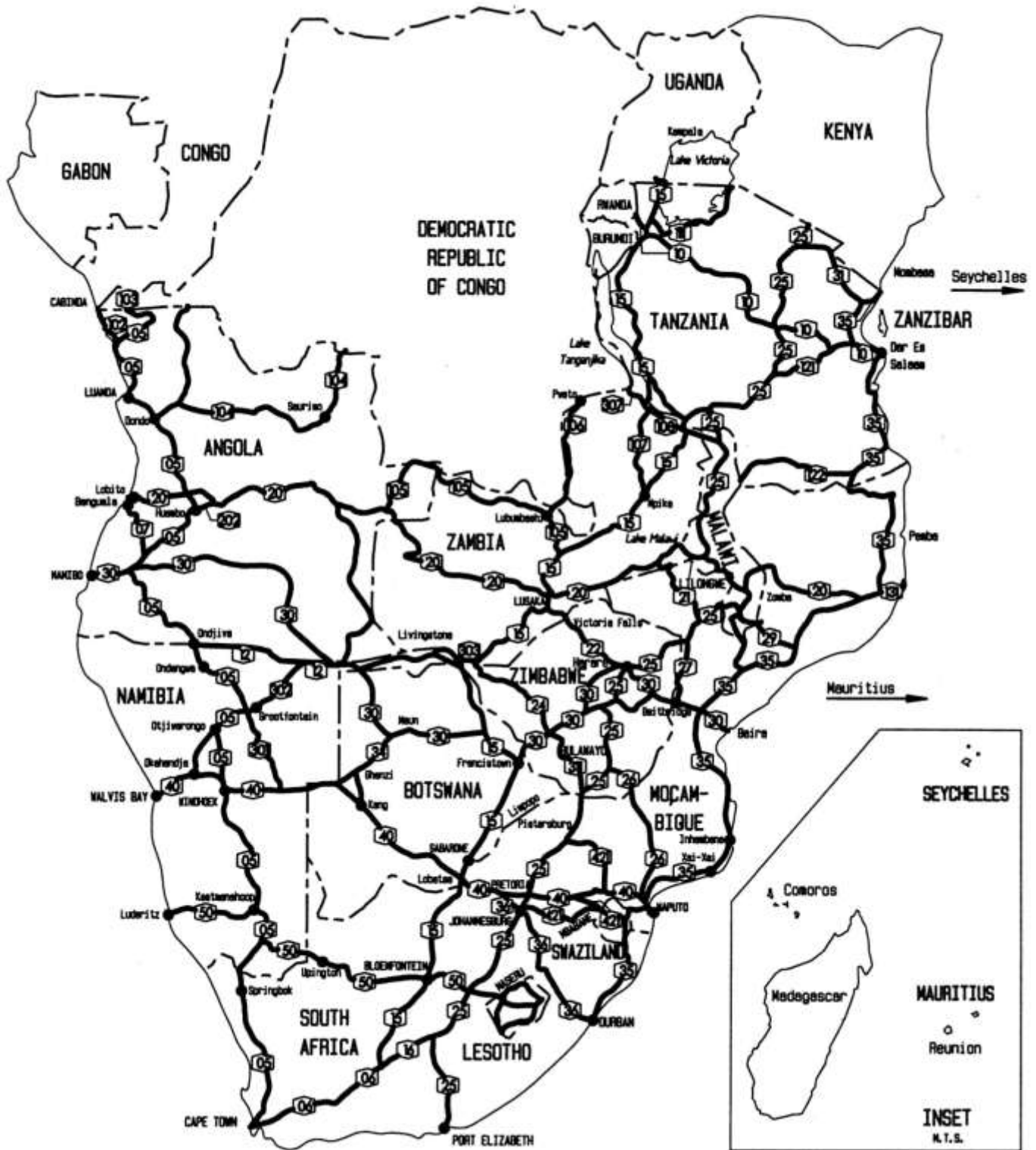

Fig 8.1

Map Showing Numbered SADC Routes
(Superimposed on Member State
Primary Routes)

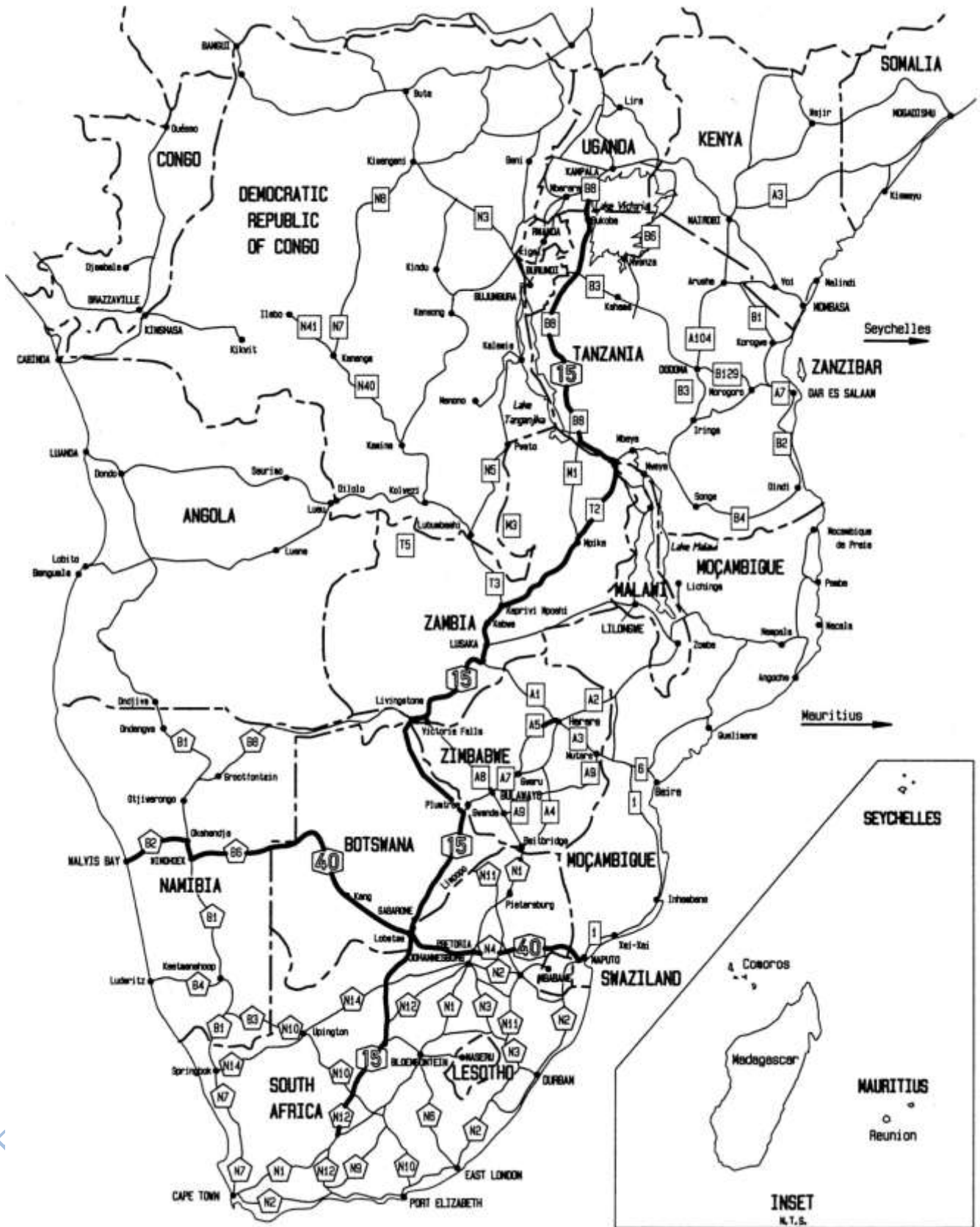

Fig 8.2 Map Showing Selected Primary Routes, and two Superimposed SADC (Inter-State) Routes (With Some Level1 and Level 2 Destinations)

8.2 TYPES OF NAVIGATIONAL AID

8.2.1 General

- 1 In order for strangers to find their way safely to a previously unvisited destination they have to have adequate access to a range of navigational aids. Such aids to navigation need to be available in an "off-the-road" form for PRE-TRIP PLANNING, and in an "on-the-road" form for IN-TRIP USE. Unvisited trip destinations may range from those visited after crossing several countries (with unknown towns and cities, which need to be successfully navigated through, along the way), to destinations in an unfamiliar part of a major metropolitan area, from that in which the driver lives and works (e.g. Johannesburg).
- 2 Aids to driver navigation may take several forms. In undertaking a trip, and particularly one into unfamiliar territory, a number, or all, of these may be utilised.
- 3 The following forms of navigational aid should be provided to road users in accordance with the provisions of subsequent Subsections:
 - (a) ROAD MAPS (including roadside maps and tourist publicity material);
 - (b) ROAD REPORTS;
 - (c) ROUTE NUMBERS;
 - (d) GUIDANCE SIGNS (including tourism signs), CONFIRMATION SIGNS, TOWN NAMES & STREET NAMES;
 - (e) PROPERTY NUMBERS, PRIVATE AND COMMERCIAL NAME SIGNS.
- (iv) all orientation points displayed as destinations on signs along the roads;
- (v) tourist attractions indicated on TOURISM signs along the roads;
- (vi) new roads under construction, or roads of which the construction in the near future has been confirmed;
- (vii) all street names in urban areas (subject to map scale);
- (d) the map should be supplemented by "Route Schedules" stating the terminal points of routes with route numbers and all other orientation points along these routes (this should include Tourist Routes when appropriate);
- (e) subsequent changes and additions to the map and schedules should be indicated in a different colour or by some other coding system.
- 4 Sign mounted roadside maps of local areas may be provided. These are used with benefit in major tourist areas and in industrial areas, where the percentage of drivers not familiar with the area may be well above average. These maps should be provided with an adequately signed pull-off area or layby, to give drivers time to take in the required information without obstructing other traffic. Typical examples of industrial area roadside maps and tourist area roadside maps are given in Chapter 5 and Section 4.10 respectively.
- 5 Local road authorities should submit information pertaining to route numbers and schedules to the controlling road authority for approval. The co-ordination and control of route numbering should be maintained by a Route Numbering Sub - Committee of the relevant Road Traffic Sign Technical Committee.
- 6 Tourist publicity material should, where practical, include mini- route maps to indicate the location of tourist attractions. The principles appropriate to road maps apply equally here.

8.2.2 Road Maps

- 1 ROAD MAPS are representations of LINKS or routes, connecting NODES or destinations, according to a hierarchical scale. A driver should use road maps to do pre-trip planning and also to monitor progress and position *en route*. **It is therefore essential that navigational information on road maps shall correlate with navigational information given on roads, and VICE VERSA.**
- 2 It is the function of map producers to print and distribute road maps to the public although authorities may provide this service themselves. **The supply of current map information to map producers is the responsibility of the road authorities.**
- 3 The information supplied to map producers should comply with the following requirements:
 - (a) the base used for the map shall be the National Geo-reference System and this shall be indicated on the map;
 - (b) the scale of the map shall suit the density of lines and shall be shown on the map;
 - (c) the map should clearly indicate as much of the following as is practical:
 - (i) freeway, toll, dual carriageway, surfaced single carriage way and un-surfaced roads;
 - (ii) **all route numbers allocated to routes;**
 - (iii) interchange exit numbers allocated to interchanges on freeways and other classes of road, together with street names in urban areas;

8.2.3 Road Reports

- 1 Road reports give up-to-date information on road and traffic conditions and warn about delays and hazardous conditions. A driver should therefore use road reports to make final adjustments to his pre-trip planning, and road reports received *en route* may give an opportunity to avoid congested or hazardous road sections.
- 2 Although this information is made known through the press, radio, television and the Internet as a general service to the public, **it is the duty of the road authorities to collect and supply this information.** Road reports for release to the media should be co-ordinated and issued by the National Road Authority through approved bodies.
- 3 Each authority responsible for a numbered route should, on request, submit accurate current road condition information for such roads to the head office of the National Road Authority. This road report shall comply with the following requirements:
 - (a) where available a suitable road map complying with the requirements given in Subsection 8.2.2 should

be marked with the sections referred to in the report;

- (b) conditions on all sections of Inter-State and Primary routes shall be described; Secondary, Tertiary and lesser routes reports need only be submitted for problem sections;
 - (c) the ROUTE NUMBER, with a description of terminal orientation points and total length of the route, shall be indicated;
 - (d) road types, namely - freeway, toll, dual carriage way, four lane undivided, three lane single carriage way (including climbing lanes), single carriage way shall be indicated;
 - (e) anticipated traffic conditions involving abnormal vehicles, high percentages of heavy vehicles, farm tractors, capacity constraints;
 - (f) special features such as:
 - (i) toll plazas;
 - (ii) rest and service areas;
 - (iii) 24-hour fuel facilities;
 - (iv) SOS services;
 - (v) arrestor beds;
 - (vi) points of scenic interest;
 - (g) sections of route which are not operating at their normal level of service for whatever reason, together with a description of the orientation points at the extreme ends and the length of section shall be given;
 - (h) hazardous conditions on sections such as :
 - (i) road-works, including detailed information on half-width construction, surfaced or gravel deviations, road closures, detours, presence of construction workers and vehicles, maintenance activities such as resealing, patching, line marking and work on shoulders;
 - (ii) poor pavement conditions such as pot-holes, uneven surface, slippery when wet, loose stones and falling rocks;
 - (iii) geometric conditions on alternative routes including sharp curves, steep grades, concealed junctions and/or entrances, surfaced or unsurfaced shoulders;
 - (iv) floods or wash-aways;
 - (v) areas prone to climatic conditions such as mist, snow, rain, or smoke;
 - (vi) high frequency accident locations;
 - (vii) any other hazardous conditions on the road.
- 4 When giving this information the road authority should relate it to orientation points along the route in question. In addition, when this is relevant, the distance for which the condition occurs should be given and the time period for which it is expected to exist. Recommended alternative routes should also be detailed, in relation to

orientation points which link into the route which is the subject of the report.

8.2.4 Route Numbers

- 1 As a road grows in importance the necessity to identify it as a specific route reaches the stage when the responsible road authority may decide to allocate a route number to it.
- 2 The allocation of a route number to a route creates an obligation on the relevant authority to place signs indicating the number of the route, and to notify map producers as soon as possible of the number and the extent of the route, in accordance with the requirements of paragraph 8.2.2.3.
- 3 Route numbering criteria are dealt with in detail in Section 8.4.

8.2.5 Guidance Signs, Confirmation Signs, Town and Street Names

- 1 Guidance signs give *en route* navigational information to guide drivers during trips, so that they may reach their destinations in safety and with the minimum of disruption. These signs shall comply with the requirements of design, placement, operation, maintenance and uniformity as set out in this Manual. Note should be taken that guidance signs are solely for the purpose of providing navigational information, and are not an advertising medium.
- 2 The decision to use a particular legend on a sign should be made on the basis of an engineering study, with the objective of guiding drivers along the optimum route to a destination.
- 3 The primary guidance signing system may be supplemented by tourism signs where appropriate as set out in Chapter 4, or Volume 2, Chapter 4: Tourism Signing.

8.2.6 Property Numbers, Private and Commercial Name Signs

- 1 All properties in urban areas must be clearly identified by a number allocated and controlled by the local authority. These should be clearly displayed, and readable by the driver, from a vehicle in motion. Letter size should conform to that appropriate to the travel speed on the road, but should not be less than 100 mm. The presence of a consistent property numbering system is important in locating the final destination. (See South African Standard Specification SANS 972: Parts 1 and 2 – 2004/2005 : *Signs for Street and Property Identification.*)
- 2 Private and commercial name signs may be used to supplement the property number.

8.3 ROUTE OPTIMISATION

8.3.1 General

- 1 The choice of an optimum route is dependent on inter-related variables, such as the level of familiarity of orientation information, the purpose of the trip, the time and cost relationships as perceived by the road user, the type of vehicle, and also the avoidance of less attractive or sensitive areas.

8.3.2 Assumptions

- 1 A system of establishing a hierarchy of Orientation Points or LEVELS (as described in Subsection 8.3.3), and subsequently identifying suitable destination points, was developed for use in South Africa. Much information regarding growth points and regional sub-developments was obtained from various government departments.
- 2 It is suggested that the various SADC member countries may establish similar systems of their own, should the South African based system prove unsuitable.
- 3 The selection of orientation points, and their levels of importance, is the foundation of an efficient guidance signing system. It has been found in South Africa that the selection of orientation points can be topical or even controversial. In the process of selecting orientation points on a numbered route, the decision to elevate town A to a higher level of classification than town B has often led to dissatisfaction. **Great care must be taken not to allow subjective arguments to cloud an objective analysis.**

8.3.3 Orientation Points

- 1 Journeys start at a place, and may proceed through various orientation points, to end at another place which, in itself, is also an orientation point. These orientation points are nodes or destinations in the route network, and are grouped in a hierarchy as set out in Table 8.1.
- 2 The familiarity of an orientation point to road users is likely to have a significant effect on the route choice, since there is a natural tendency to choose the known in preference to the unknown. Familiar orientation points are therefore more likely to affect the route choice of drivers not familiar with the area.
- 3 Orientation points must be established for PRIMARY, SECONDARY and TERTIARY routes. These are effectively rural routes, although they may traverse metropolitan areas. The establishment of orientation points within metropolitan areas can be difficult, and is likely to be most effective when carried out on a basis of historical and geographical factors. Orientation information given, on direction signs at systems interchanges on freeways in these areas, generally follow the same rules as those given for interchanges in rural areas.
- 4 When the route in question is a freeway within an urban or metropolitan area, the information given on the freeway exit signs, at an access interchange, is not generally designed to offer orientation on the freeway. The exit information displayed in urban areas at such interchanges includes the interchange exit number, the town or city name and the intersecting route number and street name(s).

- 5 In situations in urban areas where space is limited for the location of guidance signs, route numbers, followed by the appropriate cardinal direction, may be the only orientational information which can be given. In such cases it will be necessary to offer drivers confirmation or reassurance, as soon as possible after they make a turn, to indicate that they are heading towards a sufficiently familiar metropolitan orientation point.
- 6 LEVEL 1 orientation points should be established, on the basis that almost all drivers will have sufficient geographical knowledge of the chosen points, for these points to offer basic orientation, in terms of direction and distance. These points will also be most easily found on road maps, which will assist drivers who have virtually no geographical knowledge of the area.
- 7 LEVEL 2 orientation points should also be established. This can be done on the basis that nearly all drivers resident in the province concerned, will have sufficient geographical knowledge for the chosen points for them to offer orientation, in terms of direction and distance. Towns identified as main centres for sub-regional development could form the basis of this classification.
- 8 LEVEL 3 orientation points should be established in a similar way, based on the likelihood that nearly all drivers resident in a region, will have sufficient geographical knowledge for the points to offer adequate orientation in terms of direction and distance.
- 9 LEVEL 4 orientation points are higher level local authorities, which have not been included in levels 1, 2 and 3 above. Classification as a LEVEL 4 orientation point may change from time to time.
- 10 LEVEL 5 orientation points are medium level local authorities. Classification as a LEVEL 5 orientation point may change from time to time.
- 11 LEVEL 6 orientation points are lower level local authorities and other places. Classification as a LEVEL 6 orientation point may change from time to time.
- 12 LEVEL 4, 5 and 6 orientation points have been established to distinguish between destinations at the lower levels. Many of the towns/township communities chosen may be regarded as parts/suburbs of the destinations appearing in the higher levels, and must be indicated at appropriate levels in the road network.

8.3.4 Trip Purpose

- 1 The purposes which influence the choice of an optimum route are:
 - (a) business trips;
 - (b) commercial (including industrial) trips;
 - (c) trips to work and home;
 - (d) tourism/leisure trips.
- 2 In the particular case of tourists' needs for route selection, the basic direction signing system shall be adequate, to enable drivers not familiar with the area to reach the general area of their intended destination. This is always provided tourists have reasonable access to suitable up-to-date maps. **Special efforts should particularly be made to ensure that such**

maps are available to foreign visitors. When discussing signing aspects with tourist facility operators, road authority representatives are recommended to encourage such operators to include basic route identification information, relevant to numbered routes in particular, in their letterhead, booking forms or brochures.

- 3 It may be necessary in the general area of the more frequently visited tourist regions, and of the more obscure and inaccessible ones, to provide tourism signs which are supplementary to the basic DIRECTION signs system. Details of these signs are given in Section 4.10 and warrants for their use are covered in Volume 2, Chapter 4:Tourism Signing.

8.3.5 Time and Cost Relationships

- 1 The time and cost relationships which influence the choice of an optimum route are:
 - (a) minimum time;
 - (b) minimum distance;
 - (c) minimum cost.

8.3.6 Vehicle Type

- 1 The vehicle types which influence choice of the optimum route can be classified into :
 - (a) freight carrying vehicles;
 - (b) passenger vehicles;
 - (c) multi-passenger carrying vehicles.

8.3.7 Less Attractive or Sensitive Areas

- 1 Based on the knowledge that tourists will be strongly influenced by route signing, it is desirable to avoid less attractive or sensitive areas. Adaptation of route information to indicate a route other than the most obvious or direct, may be considered. Such areas include:
 - (a) central business districts;

- (b) residential areas;
- (c) poor standard roads;
- (d) security risk areas.

- 2 The signing of alternative or "preferred" routes may be accomplished within the normal parameters of direction sign policy. In certain circumstances it is likely, however, that additional signs may be necessary to supplement the basic direction sign system. This need should be restricted as far as possible by road authorities.

8.3.8 Route Identification and Signing

- 1 Route identification, by the allocation of route numbers and signing, may be used to optimise route selection, to the benefit of network capacity. The optimum route may be selected, by determining the values attached to the various factors for occasional and first time motorists, not familiar with the area, and then by selecting the best alternative after comparing the potential cost savings.
- 2 This procedure is strongly recommended for determining the optimum routes in metropolitan areas. In rural areas, however, where alternative routes are not commonly available, the selection of the optimum rural route can be simplified by considering the relative importance of destinations and assuming that passenger carrying vehicles will generally prefer the quickest route, and freight carrying vehicles will generally prefer the shortest route.
- 3 Decisions on route numbering, the selection of destinations to be displayed on guidance signs, and the use of trail blazer signs, are, over a period of time, generally part of an iterative process, based on the various optimum routes which form a network hierarchy between the various orientation points these routes serve. As such, in order to maintain a measure of optimisation in a system, changes may be necessary, with time and alterations in traffic patterns. It is, however, recommended that route numbers, once allocated, should not be changed unless as part of a major system upgrade, and such changes must be carried out with the necessary publicity.

8.4 ROUTE NUMBERING

8.4.1 General

1 When a road network becomes complex, the task of navigating within the network, or through the network, also becomes complex. This complexity is particularly a problem for visitors to a region or area, because they are not familiar with place names at the same hierarchical level as local drivers. Factors which result in such a situation are:

- (a) when pairs or sets of NODES or destinations, are served by more than one LINK;
- (b) when only one LINK is available and this serves several destinations or NODES;
- (c) when complex manoeuvres are required, in order to return to a major route serving as an exit route from the region or area.

When one or more of these factors exists, signing by destination name or street name alone is no longer adequate. This problem can be overcome by allocating a specific ROUTE NUMBER to the optimum route between ORIENTATION POINTS.

2 Although such routes could be allocated a name, this is generally considered an impractical navigational technique. Such a practice would require larger signs, which would often be difficult to fit into the available roadside space. Readability of guidance signs could be compromised, and a confusing situation could develop due to the need to display destination names **and** route names. In metropolitan areas such routes coincide with named streets. These street names may change several times along the length of a route, and to allocate a route name in such circumstances could confuse rather than assist drivers. Conversely the use of a route number can effectively combine the various sections of contiguous, but differently named streets, into a cohesive route for drivers.

3 Historically a number of routes may have been named. These may be retained provided the signing of these names is not incorporated into the navigational signing system. The signing of such routes is covered in Chapter 4.

4 In a similar manner, other *en route* features such as bridges, passes, tunnels, toll plazas, rest and service areas and tourist routes may be named and signed with benefit to the navigational process. However, such signs shall be considered as of secondary, or supplementary, value to the navigational guidance signing of routes and destinations.

5 Interchange (EXIT) or junction numbers may provide an effective supplementary navigational aid to route numbers.

8.4.2 Metropolitan Route Numbering Criteria

1 The metropolitan planning authority should co-ordinate the numbering of metropolitan routes, in consultation with the provincial road authority, and the various local authorities in the area. When the numbering system has been agreed, and the guidance signs in the area effectively indicate the relevant route numbers, it is recommended that the metropolitan planning authority

issue a route numbering map for the area. In practice this may be accomplished in co-operation with automobile associations, or map producers and should be supported by a publicity campaign.

2 An ideal situation would be one in which all trip purposes could be accommodated on a route to give minimum time, distance and cost. This is, however, not always possible, and the following criteria should be considered when deciding whether a route should be numbered, or which route should be numbered:

- (a) orientation point characteristics, such as :
 - (i) category, namely - city, town, suburb, industrial area or recreational area;
 - (ii) grade of local authority (see relevant Government publication);
 - (iii) high intensity attractors, namely - sports stadia, universities, regional shopping centres, hospitals or tourist areas;
- (b) road type and quality;
- (c) trip characteristics, such as :
 - (i) numbers of vehicles attracted;
 - (ii) quick trip preference (work and business);
 - (iii) short trip preference (commercial and industrial);
 - (iv) leisure trips;
- (d) all numbered routes should start and end at orientation points, and as far as possible at another numbered route, and be of reasonable length;
- (e) a numbered route should avoid changing direction at junctions as far as possible, and should not double back and cross itself, or cross another numbered route (except parallel minor routes), more than once;
- (f) a numbered route should be continuous throughout a metropolitan area, as well as through contiguous metropolitan areas, with the same number and symbol (care shall be exercised when numbering a route which is "circular");
- (g) all routes which are wholly contained in a metropolitan area, even if they are roads administered by a provincial authority, should preferably be given a metropolitan route number, and all rural routes passing through or terminating in a metropolitan area should retain their non-metropolitan route numbers.

3 The effectiveness of the route numbering system, in a metropolitan area, should be assessed at intervals of from five to ten years, subject to the rate of development in the area. **When** changes are made, maps shall be updated as quickly as possible and interim publicity should be initiated to make drivers aware of changes.

8.4.3 Rural Route Numbering Criteria

1 As mentioned in Subsection 8.3.7, a simplified procedure may be utilised to determine an optimum rural route between orientation points, as a candidate for route numbering. In most member states several Primary routes are numbered and it is not envisaged that major changes to them will take place. The following criteria should be applied, to decide if a route will qualify for a route number, and in what other category such a route should be classified :

(a) the population level of the relevant orientation points as given in Table 8.2:

TABLE 8.2	POPULATION	TABLE 8.2
Population of Orientation Point	Level	
> 100 000	1	
50 000 - 100 000	2	
10 000 - 50 000	3	
5 000 - 10 000	4	
500 - 5 000	5	
<500	6	

(b) the rural route hierarchy level as given in Table 8.3:

TABLE 8.3	ROUTE HIERARCHY	TABLE 8.3
Class of route	Level	
Primary	1	
Secondary	2	
Tertiary	3	

(c) the numbering of a route, and the category in which it should be numbered, are summarised in Table 8.4:

TABLE 8.4	ROUTE CATEGORY AND NUMBERING CRITERIA			TABLE 8.4
	Level from Tables 8.2 and 8.3			
Relevant Factor	Secondary Routes	Tertiary Routes	Tertiary Parallel Routes	
Route terminal orientation point population level	1 – 4 (1)	1 - 5 (1)	1 - 5 (1)	
Population level difference between route terminal points	< 2 (2)	< 3 (2)	< 3 (2)	
Route hierarchy level of joining route at terminal points	< 2	< 3	< 3	

NOTES:

- (1) These tables (8.2-8.4) indicate, for example, that a Secondary numbered route terminal orientation point, should have a population of 5000 or more.
- (2) Similarly, the population level difference, for example, for a Secondary numbered route should not be greater than two levels as given in Table 8.2. If one

route terminal has a population of 100000 the other should not have less than 10 000.

- (3) This Table indicates the levels required before a route should be allocated a number, and into which route category it should be allocated.

(d) in order to qualify as a particular category of route the following criteria as given in Table 8.5 should also be complied with:

TABLE 8.5	SUPPLEMENTARY CRITERIA			TABLE 8.5
Relevant Factor	Secondary Routes	Tertiary Routes	Tertiary Parallel Routes	
Distance between route terminal orientation points	> 100 km	>20km	>10km	
Road surface	80% of route surfaced	All weather	Fully surfaced	

- (e) When considering routes to coastal destinations, at least three of the following criteria should be satisfied:
- population of the control town must be equal to a grading higher than 5, (see Table 8.2);
 - route to join with another numbered route;
 - route should have a length not less than 20 kilometres;
 - have an all-weather surface; or
 - serve two or more communities.

- 2 Once a route has been allocated a number, the route in question should be checked, in relation to the relevant part of the overall route network, for compliance with the following:
- (a) the allocation of more than one number to one section of road, should be avoided as far as possible, but if it is unavoidable that numbered routes overlap, **all numbers shall be displayed**;
 - (b) all roads to which abnormal vehicles will be directed shall be allocated route numbers (if the route or section of route does not otherwise qualify according to the criteria laid down, it should be numbered as a Regional route);
 - (c) all numbered routes should start and finish at the appropriate level of orientation point, and as far as possible at another numbered route;
 - (d) a numbered route should avoid changing direction at road junctions, as far as possible, and it should not double back or cross itself or cross another numbered route (except parallel Regional routes), more than once;
 - (e) a number should not be allocated to a route in an urban area, which is not identified as a major route.

8.4.4 Traffic Assignments by Computer

- 1 In extremely complex situations, either metropolitan or rural, routes which may qualify for numbering, may be identified, by studying traffic volumes assigned to the network, by computer.
- 2 Such assignments normally require large quantities of data to be effective. However, such data may exist as a result of other transportation studies, in which case the use of the assignment process may be justified and indeed effective.

- 3 It is anticipated that in time the assessment of the importance of a route or LINK, and of a destination or NODE, will be computerised at primary, secondary and tertiary levels.

8.4.5 Route Number Display

- 1 Full details of the display of route numbers on guidance signs are given in Chapter 4. The points covered by the following paragraphs are of particular relevance to the navigational aids policy.
- 2 Once a route has been allocated a number, all ROUTE MARKER, DIRECTION and FREEWAY DIRECTION signs, shall display the route number appropriate to any directions and/or destinations given on the signs. The route identification letter, route number, and when applicable the cardinal direction, shall be displayed in yellow retroreflective material without any form of surrounding symbol, **EXCEPT** that on ROUTE MARKER signs the background symbol appropriate to the category of route shall be used. In the case of ROUTE MARKER CONFIRMATION signs the signs shall have the shape of the relevant symbol (see Chapter 4, Section 4.7).
- 3 When the sign indicates a route or direction which is not on the intersecting route, but is reached VIA the intersecting route i.e. "indirectly", the route number shall be displayed within brackets of yellow retroreflective material. This form of display applies to all TRAIL-BLAZER signs (see Section 4.7).
- 4 In metropolitan areas a unique background symbol may be adopted for each specific metropolitan area, for use on METROPOLITAN ROUTE MARKER signs. The symbol shall meet with the approval of all local authorities in the area, and shall also be submitted to the relevant Authority for approval (see Volume 4, Chapter 4, Section 4.3).
- 5 If a route is a toll route, the route number shall be displayed followed by the TOLL ROUTE symbol GDS9. When alternative routes to toll routes are signed, supplementary signs displaying the number of the toll route and the ALTERNATIVE ROUTE symbol GDS-10, should be erected as required to identify the alternative route. This alternative route may already have another route number, which should be displayed on the guidance signs provided according to normal principles.

Reproduced under Government Printers Authorization No. 11542 dated 7th July 2011

8.5 SELECTION OF DESTINATIONS

8.5.1 General

- 1 The message on guidance signs should enable drivers to make the correct decision regarding their next driving action, on the journey towards their final destination. In simple terms, this action is likely to be one of the following:
 - (a) to continue on the route on which they are travelling;
 - (b) to turn onto an intersecting route (either numbered or non-numbered);
 - (c) to stop for rest or service.
- 2 The minimum navigational information which drivers not familiar with the area require, to ensure a correct and safe driving action at a decision point, varies according to the road geometry of the situation. The first decision required, when a change in direction is possible, can be made on the basis of as little information as the straight-on route number and the route number of the crossing route. Approaching a high speed freeway exit this information, supplemented by the interchange exit number, can be sufficient to make the decision to exit the route on which the driver is travelling, **or not to exit**. At the off-ramp junction with the cross road, however, as with all other at-grade junctions, the minimum information shall be increased to include the route number of the cross route plus at least one orientating destination for each direction in which the driver may turn. This minimum information may be supplemented, when necessary, by other guidance signs such as TOURISM signs. Such treatment will become more appropriate at junctions with un-numbered roads at the lower levels of the road hierarchy.
- 3 The destination part of the message should orientate drivers. **It is therefore essential that the destinations displayed to drivers, when they make a change of direction, are familiar to them.** In metropolitan areas space may preclude the provision of DIRECTION signs. ROUTE MARKER signs will then represent the minimum level of guidance signing, and the orientation offered by these signs is the cardinal direction in which the sign is pointing.
- 4 The orientation message, displayed should correlate with what are familiar orientation points for drivers, whether this is as a result of knowledge gained from pre-trip planning, or general knowledge. **The objective of destination selection is therefore to display familiar orientation points, needed by drivers, to follow the optimum route to reach their final destinations.**
- 5 The selection of the destination to be displayed on any direction or confirmation sign may often seem to be a simple task. However, the increasing complexity of a modern road network, demands that a systematic and consistent approach be adopted by road authorities, whenever a destination is selected for permanent display on guidance signs.
- 6 The interchange exit number, place name, cross road route number (where allocated), and/or street name, in urban areas, will confirm to drivers what point in their journey they have reached.

8.5.2 Metropolitan Destination Selection

- 1 Since metropolitan areas invariably have a complex road network, and a wide range of available destinations for use on guidance signs, the selection of effective destinations is likely to be a difficult task. In metropolitan areas, there may be locations where an excessive number of destinations for guidance signs, would exceed the "bits of information" that the road-user can satisfactorily assimilate. In such locations it is recommended that the higher order (LEVEL 1 or METRO-LEVEL A) orientation points be used on freeways, to reduce the number of destinations to an acceptable minimum. However, when destinations are required, a traffic assignment model of the metropolitan area can be adapted to analyse the needs for destination signing. This analysis should incorporate such route network characteristics as the type and standard of the link, distances between destinations, a destination hierarchy based on category of place (e.g. city, town, suburb, industrial or recreational area) and the grade of local authority, and population size. The analysis should be sensitive to trip purpose and traffic composition, and be adaptable to take less attractive or sensitive areas into consideration. The objectives of the analysis are to compare alternative destination selections, and to establish routes which offer adequate orientational guidance to drivers not familiar with the area. In doing so the analysis should also optimise the time, distance, and cost components for all road users.
- 2 The different types of interchanges on freeways in metropolitan areas also play a major role in the selection of destination names to be displayed on direction signs. At systems interchanges, that is freeway-to-free-way interchanges, usually only long distance orientation, or LEVEL 1 information is provided as primary information, because of generally limited available space. However, in many cases LEVEL A metropolitan orientation information has to be added, in order to provide a cohesive information system. At access interchanges, that is interchanges providing access to the local street system, or the area in the immediate vicinity of the freeway or interchange, local orientation information is provided. In the case of access interchanges in urban or metropolitan areas, it is, for various reasons (including ease of identification and the correlation of information given on maps and signs), considered highly appropriate to only display the name of the crossing street, together with the route number where applicable, and not selected names from sometimes a great number of suburb names. The names of major traffic generators, such as large industrial areas and destinations outwards from the city centre should, however, be added to direction signs at such interchanges, provided that sufficient space is available.
- 3 In order to formulate a worthwhile set of policies for a metropolitan signing system a Study Team, Working Group, or Steering Committee, under the aegis of the metropolitan planning authority should be established to assume technical responsibility for all aspects of the study, including detailed methodology, procedures to be adopted, and liaison with interest groups such as the Automobile Association, Publicity Associations, Tourism Board, organised local commerce, etc.

- 4 To assist in the formulation of acceptable policies for input into the direction sign system design, the various local authorities should be consulted in addition to the core city authority and the national and provincial road authorities, to determine the existing situation regarding signing in their areas. The factors which affect the selection of destinations and routes, which are specific to the metropolitan area under study, can thus be established.
- 5 It is recommended that in formulating a systematic area policy, a minimum level of guidance signing be accepted, and that guidelines be established which indicate when a higher level of signing is appropriate. The guidelines should be based on the principles of continuity, consistency and uniformity as detailed in Chapter 4.

8.5.3 Rural Destination Selection

- 1 The selection of rural route destinations is dependent on a variety of factors. These vary from driver expectations, distances between points, classification of road, to geographical considerations. To attempt to

provide a generic procedure for all the SADC countries is considered to be impractical. Each country has its own characteristics and qualities; for example the area of Tanzania is 945 090 km², whereas the area of Mauritius is 2 040 km². Clearly the Route Numbering policy and Destination Selection procedures for these two states will be quite different. It is therefore recommended that the procedures set out below be used as a guide. An example of destination analysis procedure is contained in Section 8.6: National Variants.

- 2 The factors which influence the selection of destination names to be displayed on direction signs are:
- class of route;
 - distance between destinations;
 - classification of intersecting routes (if and when they occur).
- 3 The following procedures are recommended:
- using Tables 8.6, 8.7 and 8.8, together with the list of Orientation Points as classified according to the principles listed under Subsection 8.1.6 (including

TABLE 8.6 FAMILIAR DESTINATIONS: BASIC ORIENTATION LEVELS TABLE 8.6

Class of route	Destination to be displayed
Primary route	(a) On Class A1 or A2 roads: LEVEL 1 Orientation Point (b) On Class B roads: LEVEL 2 Orientation Point
Secondary route	LEVEL 2 orientation point
Tertiary route	LEVEL 3 orientation point

TABLE 8.7 CONTROL DESTINATIONS: BASIC ORIENTATION LEVELS TABLE 8.7

Class of Route	Destination to be displayed
Primary route	(a) On Class A1 or A2 roads: LEVEL 2 Orientation Point. (b) On Class B roads: LEVEL 3 Orientation Point.
Secondary route	LEVEL 3 Orientation Point.
Tertiary route	LEVEL 4 Orientation Point.

TABLE 8.8 SERVICE DESTINATIONS: BASIC ORIENTATION LEVELS TABLE 8.8

Class of route	Destination to be displayed (l)
Primary route:	(a) Class A1 or A2 roads: LEVEL 3 Orientation Point. (b) Class B roads: LEVEL 4 Orientation Point.
Secondary route	LEVEL 4 Orientation Point.
Tertiary route	LEVEL 5 Orientation Point.

Table 8.1) make a list, in order along the route, of all the destinations;

- (b) for each orientation point also:
 - (i) the Orientation LEVEL;
 - (ii) the distance to the nearest km, between successive points;
 - (iii) the Route Number (i.e. classification) of any intersecting route

Only listed Orientation Points are to be used.

- 4 In terms of the distance criteria, as set out in Tables 8.9, 8.10 and 8.11, these BASIC ORIENTATION LEVELS may be up-graded to the next higher level, should the km distance between successive destinations exceed those recommended.
- 5 A further criterion, i.e. the classification of the intersecting route, may also be applied to up-grade the BASIC

ORIENTATION LEVEL. Where an intersecting route passes through an Orientation Point, the BASIC ORIENTATION LEVEL may be up-graded. In this respect, the following criteria are recommended

- (a) where the intersecting route is of an **equal or higher** road classification, then the BASIC ORIENTATION LEVEL may be up-graded;
 - (b) where both distance and intersecting route criteria apply, the BASIC ORIENTATION LEVEL of orientation may be up-graded by **TWO** levels;
 - (c) on a primary route, even if both up-grading criteria are applicable, the BASIC ORIENTATION LEVEL only be up-graded **ONE** level.
- 6 Upon completion of this procedure a list of Orientation Points on the Route, together with a final classification of up-graded FAMILIAR, CONTROL and SERVICE destinations will be available. This final classification

TABLE 8.9 UPGRADED TO FAMILIAR DESTINATION TABLE 8.9

Class of route	Maximum distance between consecutive destinations and/or Intersecting Route of the same Class (or Higher)	Destination to be displayed
Primary route	150 km 100 km	(a) On Class A1 or A2 roads: LEVEL 2 Orientation Point ⁽¹⁾ (b) On Class Broads: LEVEL 2 Orientation Point
Secondary route	100 km	LEVEL 3 Orientation Point ⁽²⁾
Tertiary route	50 km	LEVEL 4 Orientation Point ⁽²⁾

TABLE 8.10 UPGRADED TO CONTROL DESTINATION TABLE 8.10

Class of Route	Maximum distance between consecutive destinations and/or Intersecting Route of the same Class (or Higher)	Destination to be displayed
Primary route	150 km 100 km	(a) On Class A1 or A2 roads: LEVEL 3 Orientation Point ⁽¹⁾) (b) On Class 8 roads: LEVEL 3 Orientation Point
Secondary route	100 km	LEVEL 4 Orientation Point ⁽²⁾
Tertiary route	50km	LEVEL 5 Orientation Point ⁽²⁾

TABLE 8.11 UPGRADED TO SERVICE DESTINATION TABLE 8.11

Class of route	Maximum distance between consecutive destinations and/or Intersecting Route of the same Class (or Higher)	Destination to be displayed
Primary route:	150 km 100 km	(a) Class A1 or A2 roads: LEVEL 4 Orientation Point ⁽¹⁾ (b) Class Broads: LEVEL 5 orientation point
Secondary route	100 km	LEVEL 5 Orientation Point ⁽²⁾
Tertiary route	50 km	LEVEL 6 Orientation Point ⁽²⁾

NOTES:

- (1) For Primary Routes it is recommended that an Orientation Level should only be up-graded by **ONE** Classification Level even if both distance and intersecting route criteria are applicable.
- (2) For Secondary and Tertiary routes, an Orientation Level **may** be up-graded by **TWO** levels if both distance and intersecting route criteria apply.

will determine what destination names appear on the direction signs (an example of this procedure, as applied to a South African route, may be found in Section 8.6).

- 7 At this stage, the destinations to be displayed on DIRECTION signs at junctions/interchanges can be determined. Depending on individual member policies, these should be "FAMILIAR", but never less than "CONTROL".
- 8 Destinations that are finally classified as SERVICE destinations should only be displayed on CONFIRMATION signs, or at a final turn towards such a SERVICE destination, if it is not located directly on the route.
- 9 Where primary routes intersect, as well as where two routes follow a common section, two destinations will have to be displayed; these could be either FAMILIAR or CONTROL depending on policy and circumstances.
- 10 In areas approaching metropolitan areas, the route network may become increasingly complex, to such an

extent that it is difficult to provide meaningful continuity of a destination name to a driver not familiar with the area. In such a case, the road authority may decide not to upgrade the basic destination classification to be displayed on DIRECTION signs, or may decide to display only orientation points that had been upgraded to "FAMILIAR" destinations.

- 11 Particular care should be taken to ensure that the terminal orientation point of a route, or the point where two coinciding routes split, is adequately signed. The road authority may decide to display such a point as a "CONTROL" or "SERVICE" destination even if it would not otherwise be warranted.
- 12 Where primary routes are being developed in such a way that certain orientation points will be by-passed by a considerable distance, it may be necessary to regard such orientation points purely as "SERVICE" destinations.

Reproduced under Government Printers Authorization No. 11542 dated 7th July 2011

8.6 NATIONAL VARIANTS

8.6.1 General

- 1 The objective of the SADC Road Traffic Sign System is to achieve the highest possible degree of harmonisation of the system throughout the region. However, due to differences in the road networks of member countries, there will be occasion for a variation of basic principles and policies. This is especially true in the establishing of a Route Numbering and Destination Selection Systems.
- 2 The principles and policies set out in this Chapter are based on a system evolved in South Africa over a period of more than 20 years. The following Subsections are examples of the application of various Navigational Aids to the South African road network. These examples are merely a guide for other member countries.

8.6.2 Orientation Points

- 1 Section 8.3 discusses the concept of Orientation Points and a method of establishing a system of grading these points into various LEVELS. **The temptation to include almost every place into the system should be avoided, since an oversupply of Orientation Points can result in a congested and ineffective Destination Analysis.**
- 2 Tables 8.12 to 8.19 list Orientation Points in South Africa as established in their LEVEL categories. These lists have been updated and revised as a result of the increase in number of provinces in South Africa.
- 3 Tables 8.20 to 8.23 similarly list destinations of different levels of importance for Namibia. Other member states are encouraged to prepare similar lists which can be added to this chapter when available.
- 4 It should also be noted that Orientation Points in Metropolitan Areas are defined and identified at METRO LEVEL.

8.6.3 South Africa - Route Number Allocation

- 1 All route numbers shall comprise a route identification letter together with the specific number allocated to the route. Additional information (toll route symbol, alternative route symbol or cardinal direction letter) may be displayed with the route number. This is detailed in Chapter 4.
- 2 The following number groups have been allocated to the different route categories. These allocations were made when South Africa consisted of four provinces, hence the varied groupings in the R300 to R499 category, as well as the R500 to R599 category.
 - (a) National Routes: N1 to N20;
 - (b) Provincial Routes: R21 to R99;
 - (c) Regional Parallel Routes: R1xy (where xy is the number of the parallel National Route; e.g. R104 is parallel to the N4);
 - {d} Regional Routes in the Eastern, Western and Northern Cape: R300 to R499;
 - (e) Regional Routes in Gauteng, Mpumalanga, Northern Province and North West : R500 to R599;
 - (f) Regional Routes in KwaZulu-Natal: R600 to R699;
 - (g) Regional Routes in the Free State: R700 to R799;
 - (h) Metropolitan Routes: M followed by any number -

but not to conflict with any adjacent National, Provincial or Regional route number;

- (i) Tourist Routes: "T" followed by a number (refer to Volume 2, Chapter 4: Tourism Signing).
- 3 At the time of publishing no routes have been allocated numbers in the R200 to R299, or R800 to R999 groups.
- 4 In the case of new or upgraded routes crossing provincial borders, the Route Numbering Working Group shall co-ordinate and award new route numbers. In the case of all other route numbers the relevant Provincial road authority or metropolitan planning authority can decide on new numbers within the limits stated. Details of all new routes and their numbers must be submitted to map producers and to the Secretary of the Route Numbering Working Group.

8.6.4 South Africa - Rural Destination Selection- Corridor Procedure

- 1 The procedures given in the following paragraphs, and as set out in Figure 8.2 illustrate the methodology recommended in Subsection 8.5.3 to determine rural route destinations.
- 2 The example considers National Route N4 between Pretoria and Maputo. From Pretoria to east of Middeburg the route is a Class A1 road, then it becomes a Class A2 road up to Machadodorp, and a Class B road to Maputo.
- 3 The basic methodology recommends an up-grading of orientation points by one level if they are situated on a Class B or lesser route; i.e. a Level 3 SERVICE Orientation Point would be deemed to become a CONTROL Orientation Point. However, if this application results in a preponderance of FAMILIAR orientation points in the final analysis, it is recommended that the result be reviewed. It is recommended that on Primary routes a Basic SERVICE destination may not be up-graded to a FAMILIAR destination.
- 4 With the aid of a road map, write down all the place names, in order, along the N4 route, starting from Pretoria, to Maputo. These names must only be names from the list of established ORIENTATION POINTS, as listed in Tables 8.12 to 8.14 (Figure 8.3-Column 1).
- 5 Next to these names write down the BASIC ORIENTATION LEVEL, as set out in Tables 8.6 to 8.8 (Figure 8.3 -Column 2).
- 6 Using a route number map, write down all the NUMBERED ROUTES joining the N4 at (or near) these orientation points (Figure 8.3 • Column 3).
- 7 In the next column write down the POINT TO POINT KM DISTANCE between these orientation points (Figure 8.3 - Column 4).
- 8 Now write down the BASIC ORIENTATION LEVEL CLASSIFICATION in Column 5, based on Table 8.1, as well as taking into consideration the road classification (Figure 8.3 - Column 5).
- 9 The process of possible up-grading now takes place. Assess, according to the distance criteria, if the Orientation Level must be upgraded (Yes/No) (Figure 8.3- Column 6).
(Continued on page 8.6.8)

TABLE 8.12		LEVEL 1 (FAMILIAR) ORIENTATION POINTS- RSA					TABLE 8.12	
Eastern Cape	Free State	Gauteng	Kwazulu/ Natal	Mpumalanga	Northern Cape	Limpopo	North West	Western Cape
King Williams Town	Bloemfontein	Johannesburg	Durban	Nelspruit	Kimberley	Pietersburg	Mafikeng	Cape Town
East London		Pretoria	Pietermaritzburg					
Port Elizabeth								

TABLE 8.13		LEVEL 2 (CONTROL) ORIENTATION POINTS- RSA					TABLE 8.13	
Eastern Cape	Free State	Gauteng	Kwazulu/ Natal	Mpumalanga	Northern Cape	Limpopo	North West	Western Cape
Aliwal North	Bethlehem	Alberton	Amanzimtoti	Bethal	De Aar	Louis Trichardt	Klerksdorp	Beaufort-West
Cradock	Bothaville	Benoni	Ballito	Ermelo	Kuruman	Phalaborwa	Lichtenburg	Bellville
Graaff-Reinet	Botshabelo	Boksburg	Dundee	Middelburg	Prieska	Potgietersrus	Potchefstroom	Caledon
Grahamstown	Ficksburg	Brakpan	Empangeni	Secunda	Springbok	Thohoyandou	Rustenburg	George
Middelburg	Harrismith	Carletonville	Eshowe	Standerton			Vryburg	Malmesbury
Queenstown	Kroonstad	Centurion	Estcourt	Witbank				Mossel Bay
Uitenhage	Mangaung	Germiston	Graytown					Oudtshoorn
Umtata	Maokeng	Heidelberg	Hawick					Saldanha
	Odendaalsrus	Kempton Park	Isipingo					Vredenburg
	Parys	Krugersdorp	Kokstad					Vredendal
	Phuthaditjhaba	Nigel	Ladysmith					Worcester
	Sasolburg	Randburg	New Germany					
	Thabong	Randfontein	Newcastle					
	Virginia	Roodepoort	Ningizimu					
	Welkom	Sandton	Pinetown					
		Soweto	Port Edward					
		Springs	Port Shepstone					
		Vanderbijlpark	Queensburgh					
		Vereeniging	Richards Bay					
			Stanger					
			Tongaat					
			Umhlanga					
			Verulam					
			Vryheid					
			Westville					

TABLE 8.14 LEVEL 3 (SERVICE) ORIENTATION POINTS- RSA TABLE 8.14

Eastern Cape	Free State	Gauteng	Kwazulu/ Natal	Mpumalanga	Northern Cape	Limpopo	North West	Western Cape
Burgersdorp	Bainsvlei	Akasia	Glencoe	Balfour	Colesburg	Ellisras	Brits	Bredasdorp
Butterworth	Frankfort	Bedfordview	Hluhluwe	Barberton	Douglas	Giyani	Christiana	Ceres
Fort Beaufort	Heilbron	Bekkersdal	Kingsburgh	Carolina	Keimoes	Messina	Fochville	Clanwilliam
Humansdorp	Henneman	Bronkhorstspuit	Kloof	Delmas	Postmasburg	Naboomspruit	Hartbeespoort	Grabouw
Port Alfred	Ladybrand	Daveyton	Marburg	Evander	Upington	Namakgale	Jan Kempdorp	Hermanus
Stutterheim	Reitz	Edenvale	Margate	Groblersdal	Warrenton	Nylstroom	Orkney	Knysna
Uitenhage	Senekal	Evaton	Mkuze	Kinross		Seshego	Schweizer-Reneke	Moorreesburg
	Thaba Nchu	Kagiso	Mooi River	Leandra		Thabazimbi	Stilfontein	Paarl
		Kwa-Thema	Nongoma	Lydenburg		Tzaneen	Ventersdorp	Piketberg
		Meyerton	Scottburgh	Marble Hall		Warmbaths	Zeerust	Plettenberg Bay
		Midrand	Ulundi	Piet Relief				Riversdale
		Modderfontein	Utrecht	Volksrust				Robertson
		Sebokeng	Uvongo	White River				Somerset-West
		Tembisa	Winkelspruit					Stellenbosch
		Vosloorus						Strand
		Westonaria						Swellendam
								Velddrif
								Wellington

TABLE 8.15 LEVEL 4 (SERVICE) ORIENTATION POINTS RSA TABLE 8.15

Eastern Cape	Free State	Gauteng	Kwazulu/ Natal	Mpumalanga	Northern Cape	Limpopo	North West	Western Cape
Aberdeen	Allanridge	Lenasia	Dannhauser	Belfast	Barkly-west	Duiwelskloof	Bloemhof	Ashton
Adelaide	Brandfort	Randvaal	Eston	Breyten	Britstown	LebowaKgomo	Coligny	Bonnievale
Barkly-East	Bultfontein		Harding	Hectorspruit	Carnarvon		Delareyville	Brackenfell
Despatch	Hoopstad		Mandini	Komatipoort	Danielskuil		Koster	Darling
Elliot	Koffiefontein		Matatiele	KwaMhlanga	Kakamas		Leeudoringstad	De Doorns
Joubertina	Masilo		Munster	Malelane	Noupoort		Thembaletu	Durbanville
Kirkwood	Petsana		Richmond	Sable	Olifantshoek		Wolmaranstad	Franschhoek
Somerset-East	Phiritona		St Lucia	Trichardt	Port Nolloth			Goodwood
Venterstad	Phomolong		Umbogintwini	Waterval-Boven	Victoria West			Gordons Bay
Willowmore	Theunissen		Umtentweni					Grootbrakrivier
	Viljoenskroon		Umzinto North					Hartenbos
	Villiers		Umzinto					Heidelberg
	Vrede							Kleinmond
	Vredefort							Ladismith
	Wepener							Laingsburg
	Wesselsbron							Lambert's Bay
	Winburg							Langebaan
	Zastron							Mbekweni
								Mitchell's Plain
								Montagu
								Muizenburg
								Porterville
								Stilbaai
								Touws River
								Tulbach
								Vanrhynsdorp
								Villiersdorp
								Wolseley

TABLE 8.16

LEVEL 5 (SERVICE) ORIENTATION POINTS-RSA

TABLE 8.16

Eastern Cape	Free State	Gauteng	Kwazulu/Natal	Mpumalanga	Northern Cape	Limpopo	North West	Western Cape
Alexandria	Bethulie	Cullinan	Assagay	Amersfoort	Boichoko	Mahwelereng	Ipelegeng	Albertinia
Barkley-East	Boshoff	Magaliesburg	Bendigo	Amsterdam	Brandvlei	Marken	Makwassie	Barrydale
Bedford	Clarens	Munsieville	Bergville	Badplaas	Calvinia	Settlers	Ottosdal	Betty's Bay
Boesmansriviermond	Clocolan	Nancefield	Camperdown	Balmoral	Delportshoop	Tolwe	Reivilo	Bitterfontein
Cathcart	Deneyville	Rayton	Colenso	Clewer	Fraserburg	Tshipise	Sannieshof	Calitzdorp
Dordrecht	Dewetsdorp		Gillits	Graskop	Garies		Swartruggens	Citrusdal
Engcobo	Edenburg		Hambanati	Greylingstad	Griekwastad		Tshing	De Rust
Hankey	Edenville		Hibberdene	Hendrina	Grobiershoop			Graafwater
Indwe	Excelsior		Hillcrest	Kaapmuiden	Hopelawn			Greyton
Jansenville	Fauresmith		Hilton	Kriel	Kenhardt			Hopefield
Kei Mouth	Fouriesburg		Ixopo	Machadodorp	Loeriesfontein			Klawer
Keiskammahoek	Hertzogville		Melmoth	Mashishing	Marydale			Lingeletu
Kenton-on-Sea	Hobhouse		Mtubatuba	Montrose	Nonzwakazi			Murraysburg
Kirkwood	Jacobsdal		Mtunzini	Ogies	Paballelo			Napier
Klipplaat	Jagersfontein		Paulpietersburg	Ohrigstad	Petrusville			Onrusrivier
Komga	Kestell		Pennington	Phola	Philipstown			Prince Alfred
Lady Grey	Koppies		Pongola	Pilgrims Rest	Pofadder			Prince Alfred Hamlet
Lusikisiki	Lindley		Ramsgate	Siyabuswa	Richmond			Riviersonderend
Maclear	Marquard		Shelly Beach	Wakkerstroom	Ritchie			St Helena Bay
Molteno	Matwabeng		Sobantu		Strydenberg			Stanford
Mount Frere	Memel		Steadville		Sutherland			
Pearston	Namahadi		Umdloti Beach		Vander Kloof			
Peddie	Paul Roux		Umkomaas		Williston			
Port St Johns	Petrus Steyn		Weenen					
Seymour	Petrusburg		Yellow Wood Park					
Sterkstroom	Philippolis							
Steynsburg	Rammulotsi							
Steytlerville	Reddersburg							
Tarkastad	Rouxville							
Ugie	Smithfield							
	Springfontein							
	Steynsrus							
	Tembalihle							
	Trompsburg							
	Tweeling							
	Tweespruit							
	Ventersburg							
	Warden							

TABLE 8.17

LEVEL 6 (SERVICE) ORIENTATION POINTS-RSA

TABLE 8.17

Eastern Cape	Free State	Gauteng	Kwazulu/ Natal	Mpumalanga	Northern Cape	Limpopo	North West	Western Cape
Addo	Arlington	Bapsfontein	Ashburton	Burgersfort	Andriesvale	Alldays	Amalia	Agulhas
Alicedale	Cornelia	Devon	Blythedale	Chrissiesmeer	Campbell	Baltimore	Bray	Atlantis
Ann's Villa	Dealesville	Ennerdale	Bothas Hill	Dullstroom	Hanover	Dendron	Broederstroom	Aurora
Baroe	Kransfontein	Hammanskraal	Canelands	Hazyview	Hotazel	Gravelotte	Derby	Avontuur
Bathurst	Luckoff		Cato Ridge	Karino	Kamieskroon	Haenertsburg	Hartbeesfontein	Doringbos
Cofimvaba	Oranjeville		Cedarville	Morgenzon	Kathu	Hoedspruit	Lykso	Eendekuil
Cookhouse	Rosendal		Creighton	Stoffberg	Kleinsee	Klaserie	Ottoshoop	Eerste Rivier
Flagstaff	Soutpan		Dalton	Van Dyksdrif	Kraankuil	Letsitele	PielPlessis	Gansbaai
Hamburg	Van Stadensrus		Darnall		Lime Acres	Mica	Stella	Gouda
Hofmeyer	Verkeerdevlei		Drummond		Loxton	Northam	Taung	Groot Drakenstein
Hogsback	Verkykerskop		Everton		Lutzville	Roedtan	Vergelee	Herbertsdale
Idutywa			Gingindlovu		Mata-Mata	Soekmekaar		Herolds Bay
Jamestown			Hattingspruit		Matsap	Vivo		Hotagterklip
Kareedouw			Himeville		Middelpos			Hottentotskloof
KeiRoad			Ilovo		Mount Rupert			Khayelitsha
Klipfontein			Kranskop		Nieuwoudtville			Klaarstroom
Magusheni			Mariaanhill		Onseepkans			Klipheuwel
Middledrift			Marina Beach		Sakrivier			Koringberg
Mount Ayliff			Mount Michael		Schmidtsdrif			Kraaifontein
Mount Fletcher			Mpolweni		Steinkopf			Leeu-Gamka
Nieu-Bethesda			Saicor		Three Sisters			Matjiesfontein
Patensie			Southbroom		Twee Rivieren			McGregor
Paterson			Talana		Van Wyksvlei			Nuwerus
Qumbu			Umhali		Vosburg			Port Beaufort
Riebeek-East			Underberg		Windsorton Road			Prince Albert
Sada			Wartburg					Prince Albert Road
Spitskopvlei			Widenham					Rawsonville
St Francis Bay			Winterton					Riebeek-Castle
Sterkspruit			Zinkwazi					Riebeek-West
Whittlesea								Sedgefield
Wolwefontein								Stormsvlei
								Strandfontein
								Struisbaai
								Suurbraak
								Uniondale
								Van Wyksdorp
								Voorspoed
								Wemmershoek

TABLE 8.18

NO LEVEL ALLOCATED ORIENTATION POINTS - RSA

TABLE 8.18

Eastern Cape	Free State	Gauteng	Kwazulu/Natal	Mpumalanga	Northern Cape	Limpopo	NorthWest	Western Cape
Alice	Vegkop		Hekpoort	Babanango Orpen Gate		Crocodile Mabopane		Cango Caves
Coega				Bridge Gate				Kuilsrivier
Kidds Beach		Walkerville	Balgowan	Malelane Gate		Pafuri Gate	Pudimore	Waenhuiskrans
Lady Frere			Bulwer	NumbiGate		Paul Kruger Gate	Sun City	Yzerfontein
Mqanduli			Inchanga	Roossenekal		Phalaborwa Gate		
			Lions River			Punda Maria Gate		
Ngqeleni Rhodes			Midmar					
			Nottingham Road					
Willowvale Tsole			Park Rynie					
			Rosetta					
			Umlaas Road					

TABLE 8.19

BORDER POST ORIENTATION POINTS - RSA

TABLE 8.19

Botswana	Lesotho	Mozambique	Namibia	Swaziland	Zimbabwe
Bray	Maseru Bridge	Lebombo	Nakop	Border Gate	Beit Bridge
Groblersbrug	Van Rooyenshek	Ressano Garcia	Vooldrif	Jeppe's Reef	
Pioneer Gate				Mahamba Border Post	
Pontdrif				Nerston	
Stockpoort				Oshoek	
Werda					
Zanzibar Border Port					

1	2	3	4	5	6		7	8
Orientation Place Name	Orientation Point Category	Junction Routes	Distances km	Basic Classification	To be up-graded?			FINAL CLASSIFICATION
					Distance Criteria	I/S Route Criteria		
Pretoria	LEVEL 1	N1, R21, R28		Familiar	N/A	N/A		FAMILIAR
Bronkhorstspuit	LEVEL 3	R25, R42	57	Service	No	No		SERVICE
Balmoral	LEVEL 5	R545, R104	24	Service	No	No		SERVICE
Witbank	LEVEL 2	N12, R544, R555	24	Control	No	Yes		FAMILIAR
Middelburg	LEVEL 2	N11, R35, R555	32	Control	No	Yes		FAMILIAR
<i>National Class A1 and A2</i>			45					
<i>National Class B</i>								
Belfast	LEVEL 4	R33, R540	77	Service	No	No		SERVICE
Machadodorp	LEVEL 5	R36, R541	22	Service	No	No		SERVICE
Waterval Boven	LEVEL 4	-	13	Service	No	No		SERVICE
Montrose	LEVEL 5	R539	65	Service	No	No		SERVICE
Nelspruit	LEVEL 1	R37, R40	31	Familiar	N/A	N/A		FAMILIAR
Karino	LEVEL 6	R538	39	Service	No	No		SERVICE
Kaapmuiden	LEVEL 5	R38	26	Service	No	No		SERVICE
Malelane	LEVEL 4	R570	19	Service	No	No		SERVICE
Hectorspruit	LEVEL 4	-	18	Service	No	No		SERVICE
Komatipoort	LEVEL 4	R571	26	Service	No	No		SERVICE
Lebombo	LEVEL 2	-	3	Control	*Border Post			CONTROL
Maputo	LEVEL 1	-		Familiar	N/A	N/A		FAMILIAR

Rep.

Fig 8.3 Example of Destination Selection for a Rural National Route

(Continued from page 8.6.1)

- 10 Similarly evaluate the intersecting route criteria for possible upgrading (Yes/No) (Figure 8.3- Column 7).
- 11 Bearing in mind the recommendations of paragraph 8.5.3.5 the **FINAL ORIENTATION LEVEL CLASSIFICATION**, i.e. FAMILIAR, CONTROL or SERVICE is entered in the last Column (Figure 8.3 - Column 8). It is upon these classifications that the destinations appearing on the directions will be established.
- 12 The destinations to appear on the DIRECTION signs at the interchange and intersections can now be determined. As a rule, only FAMILIAR destinations are shown on these signs. Should a roads authority wish, a policy of showing CONTROL destinations on lower class roads may be implemented.
- 13 Examples of destinations to be displayed at various intersections on the N4 are as follows:
- (a) interchange R25 with N4 at Bronkhorstspuit: eastbound - Witbank; westbound - Pretoria;
- (b) intersection R36 at Machadodorp: eastbound - Nelspruit; westbound - Middelburg;
- (c) intersection R38 at Kaapmuiden: eastbound - Maputo; westbound - Nelspruit.
- 14 The use of CONFIRMATION signs has a two-fold function. It enables the display of CONTROL and SERVICE destinations, simultaneously indicating to the motorists the travelling distances involved. The CONFIRMATION signs on the route should display the next "Service", and either the next "Control" or the next "Familiar" destination, depending on the policy adopted, together with the distances to them. The FIRST CONFIRMATION sign following an orientation point used as a destination, or following a junction with a route classified as an equal or a higher order route, should display the next Service destination, and either the next Control or Familiar destination, as well as the last Familiar destination on the route (if this is not already displayed) and the distances to them. For example in this case when departing from Nelspruit in the direction of Pretoria the FIRST CONFIRMATION sign shall display:

Next Service destination	:Montrose	31
Next Control destination	:Middelburg	222
Last Familiar destination	:Pretoria	333

Subsequent CONFIRMATION signs at 10 km intervals shall only display the next Service, and either the next Control or Familiar destination. These signs should be positioned in such a way that the distance to the Service destination is in multiples of 10 km, for example:

	N4	
Montrose		20
Middleburg*		211

*In this case there is no subsequent CONTROL destination so that Middelburg has to be used

- 15 **Care must be taken to ensure that once a destination is shown on any guidance sign, that the destination is repeated and carried through on all relevant successive signs until that destination is reached.**
- 16 Subsections 4.8.7 and 4.9.17 deal with the display and

location of CONFIRMATION signs. Notwithstanding the recommendations in these subsections the following policy with respect to CONFIRMATION signs are suggested:

- (a) confirmation signs shall show two destinations, except after Systems Interchanges and major route intersections, when there shall be three destinations. In addition a three destination display may be provided at 100 km intervals;
- (b) the top destination shall be the next orientation point (regardless of classification);
- (c) the bottom destination shall be the first destination of the next higher orientation classification. Simply put a CONFIRMATION sign display will normally show the following:

Service	or	Service
Control		Familiar
Control	or	Familiar
Familiar		Familiar

The second destination shall never be of a lower orientation classification than the first (upper) destination.

8.6.5 South Africa – Rural Destination Selection- Junction Procedure

- 1 At certain junctions, or splits of primary routes it will be necessary to display two orientation points for each leg of the junction, with the proviso that sufficient space is available on the signs. The first orientation name for each leg must be that name derived in the manner described in Subsection 8.5.4, while the second name must be the next familiar orientation point for that particular leg as given in Table 8.12.
- 2 As an example, the junction between the N1 and N9 National Routes at Colesberg may be considered. Travelling in a southbound direction the following destination selection for display on direction signs at this junction is appropriate:
- (a) the N11eg should firstly display "Beaufort West", as a control destination, together with the route number "N1", (this is derived from the described procedure); the second destination to be shown on signs for the N1 leg is "Cape Town", which is the next Basic FAMILIAR orientation point on that route as given in Table 8.12;
- (b) the N9 leg should firstly display "Middelburg", as a control destination, together with the route number "N9" (this is derived in the described procedure); the second destination to be shown on signs for the N91eg is "Port Elizabeth", together with the "(N10)" indirect route number, because the N10 continues from Middelburg in the general direction of Port Elizabeth, while the N9 continues towards Graaff Reinet (the N10 route does not terminate in Port Elizabeth, but at a distance of approximately 25 kilometres to the east of Port Elizabeth on the N2 it is not considered necessary to indicate the (N2) on the signs at this point).
- (c) the above amount of information falls within the maximum number of "bits" allowed;
- (d) the **first** confirmation sign on the N1 route beyond the junction should show the following :

	N1	
Hanover		72
Beaufort West		242
Cape Town		778

((N1) Kroonstad (N12)
 (N1) Bloemfontein (N12)
 Potchefstroom (N12)
 Kimberley (N12)
 Johannesburg

R24 - west

While the **next** confirmation on the N should show:

	N1	
Hanover		60
Beaufort West		230

(e) the **first** confirmation sign on the N9 route beyond the junction should show the following :

	N9	
Noupoort		55
Middelburg		96
(N10) Port Elizabeth		453

Due to the route configuration, a **second** confirmation sign may be positioned on this route showing:

	N9	
Graaff Reniet		202
George		544

8.6.6 South Africa - Destination Selection for National Freeways in Metropolitan Areas

1 The prescribed procedure shall also be followed for the selection of destinations on National Route freeways in metropolitan areas as these routes may be regarded as long distance routes which continue through, or "bypass" these areas. At certain interchanges on such routes it is required that the next FAMILIAR orientation point, as given in Table 8.12 also be shown together with the selected control destinations, with the proviso that the maximum allowable amount of information on individual signs is not exceeded. In cases where the allowable maximum amount of information on signs will be exceeded, the selected control destinations for particular routes shall be omitted, and only the FAMILIAR destinations shall be shown (together with the standard interchange/route information).

2 As an example, the junction between the N3 and N12 National Routes to the east of Johannesburg may be considered:

(a) travelling in a westerly direction, towards Johannesburg destinations for three routes, or directions, beyond the interchange have to be considered for display on overhead signs; these routes are:

- N3- north
- N3- south and the N 2- south
- R24- west;

(b) the candidate destinations to be shown are the following:

- N3- north : Sandton
(N1) Midrand
(N1) Pretoria
- N3- south: Alberton (N3)

Heidelberg (N3)
Durban (N3)
(M2) Johannesburg (N3)
- N12- south: (R26) Vereninging (N12)
Soweto (N12)

(c) the requirements clearly exceed by far the available space, and the maximum allowable amount of information; even in selecting only the most needed destinations to be shown, together with other essential information (arrows, distance, route and interchange exit numbers) it is difficult to keep within the required limits (see paragraph 8.6.6.2(d));

(d) in this case it is clear that the derived destinations (including amongst others Heidelberg, Kroonstad and Potchefstroom) will have to be omitted, and ONLY familiar or LEVEL 1 destinations indicated; the destinations to be shown should, therefore, be as follows:

- N3- north: (N1) Pretoria
- N3 and N2 south: Durban
(M2) Johannesburg
Soweto
(N1) Bloemfontein
Kimberley
- R24: Johannesburg,

(This is still somewhat in excess of the required maximum.)

(e) confirmation signs, preferably not more than two, may, however be provided on each of the routes leaving the interchange, on which the distances to the destinations which were omitted, may be shown.

3 The above example serves to illustrate that if the prescribed procedure of selecting only one destination per junction leg from LEVEL 2 or 3 destinations, insufficient information would have been provided to adequately serve as orientation information.

8.6.7 South Africa - The Selection of Destinations at Smaller Urban Areas and Towns which are By-passed by Freeways

1 When a Class A road, or freeway, by-passes a smaller urban area or town, the type of signface display on the freeway will need to be chosen, i.e. rural signface layout or urban signface layout. Since there are a number of established rules of signface layout, some of which have been described in earlier subsections, certain existing factors will dictate whether the signface treatment should be rural or urban. These factors include:

- (a) whether the roads intersecting the freeway have already been allocated street names;
- (b) the proximity of the freeway to the urban area;
- (c) the number of interchanges serving the urban area.

2 When a smaller urban area or town is by-passed by a freeway, and the roads which intersect the freeway, and give access to the urban area, have been allocated

street names, the freeway signs shall be designed according to the urban signface design principles. This

requires the inclusion of the town name in a panel at the top of the signs, next to the interchange/exit number, and the use of the street name, in addition to any allocated route number, as the first exit "destination". "CBD" symbol GDS - 8 should precede the most appropriate street name (or only street name in the case of a single access). In addition the name of a destination which can be reached using the crossroad in question, in the opposite direction to the town, should be given. The selection of this destination should be according to normal rural destination selection principles, as applicable to the intersecting crossroad.

- 3 When a smaller urban area or town is by-passed by a freeway, and the freeway is close to the town, the freeway signs may be designed according to either urban signface design principles or rural signface design principles. In the context stated, "close" can be considered to be in a range between one kilometre and 10 kilometres. The closer the freeway is to the town, the more appropriate, and likely, the use of an urban signface treatment should be. If development of the urban area is likely to move up to, and/or even be stimulated on the outer side of the freeway (this is a common result of the construction of by-passing freeways), then the use of urban signface design principles is recommended. This may require a request to the local authority to name the relevant street, or streets, giving access to the town. In the same manner as described in paragraph 8.6.7.2, "CBD" symbol GDS -8 and the name of a destination which can be reached using the crossroad in question, in the opposite direction to the town, should be given in addition to the normal urban information.
- 4 If prevailing or planned conditions indicate that the freeway/town environment is likely to be a rural one for the life of the freeway signs (7 to 10 years), then the manner of freeway signface design shall be according to rural signface principles. Exactly how this is achieved will depend on the number of interchanges which provide access to the town. The information on the signfaces shall include the interchange/exit number, any route number allocated to the crossing road, and at least two orientational destination names, one to the right of the freeway and one to the left of the freeway. The following procedure is recommended regarding the indication of the town name as one of these orientational destinations, according to the number of intersecting roads which give access to the town :
 - (a) when only ONE interchange on the freeway gives access, the signs shall be designed according to rural signface design principles;
 - (b) when TWO interchanges on the freeway provide access to the town, the name of the town will appear at both interchanges; in order to improve the quality of the orientation provided under these circumstances, the cardinal or "compass" area of the town reached from each interchange shall be indicated, after the town name in capital letters and within brackets, e.g. Howick (NORTH) and Howick (SOUTH);
 - (c) when THREE interchanges on the freeway provide access to the town, the name of the town will appear at all three interchanges; in order to improve the quality of the orientation provided under these circumstances, the cardinal or "compass" area of the town reached from the two "outer" interchanges

shall be indicated, after the town name in capital letters and within brackets, e.g. Mossel Bay (EAST) and Mossel Bay (WEST); if the central interchange serves the central business area of the town then the "CBD" symbol GDS- 8 should precede the town name on the signs for this interchange, OR this interchange should be signed according to urban signface design principles, including the use of "CBD" symbol with the relevant street name.

- 5 If the geographical layout of a town served by three interchanges does not suit the signing described in paragraph 8.6.7.4(c), or the town is served by more than three interchanges, urban signface design principles shall be used, after the allocation of street names to the relevant roads by the local authority.

8.6.8 South Africa - Destination Display

- 1 Full details of the rules relating to destination display on guidance signs are covered in Chapter 4, Sections 4.1 to 4.4, as well as in the individual sign type Subsections of Chapter 4.
- 2 In general, only destinations on or near the optimum route should be displayed for that route. A destination not served by the optimum route should only be displayed if treated as a trailblazer or "indirect" display. Only the actual route number by which the destination can ultimately be reached should be treated as an "indirect" component. In this context it should appear on the sign face in brackets. TRAILBLAZER signs and trailblazing information are covered more fully in Sections 4.7 to 4.9.
- 3 As rural roads continue through, or by-pass non metropolitan urban areas it is necessary that the derived "ideal" primary guidance signing system be communicated to these affected authorities. A procedure should be adopted and whereby urban authorities, the Auto- mobile Association, Tourism Board, Regional Development Associations etc. discuss and agree to guidance signing proposals, according to the principles, and where necessary contribute to the development of the Motorist Information System. Formal acceptance of the proposals by urban authorities is essential.

8.6.9 Namibia- Destination Tables

- 1 Tables 8.20 to 8.23 show the Namibian destination classification resulting from a similar destination selection process to that described in the paragraphs above for South Africa.
- 2 This selection process, and the tabulation of the destinations, enables any road authority or their agent (a consulting engineer for example) to prepare correctly designed direction signs for any node or intersection in the Namibian road network.

TABLE 8.20	LEVEL 1 (FAMILIAR) DESTINATIONS- Nam				TABLE8.20
Ariamsvlei	Keetmanshoop	Noordoewer	Otjiwarongo	Tsumeb	
Ecnhana	Luderitz	Opuwo	Rundu	Utapi	
Gobabis	Mariental	Oshakati	Swakopmund	Walvis Bay	
Katima Mulilo	Ngoma	Oshikango	Trans-Kalahari	Wndhoek	

TABLE 8.21	LEVEL 2 (CONTROL) DESTINATIONS- Nam				TABLE 8.21
Aranos	Henties Bay	MaltahOha	Omaruru	Terrace Bay	
Aroab	Hohlweg	Mala Mata	Ondangwa	Tsumkwe	
Aus	Kalkrand	Mohembo	Oranjemund	Uis	
Bethanien	Kamanjab	Namutoni	Otavi	Usakos	
Divundu	Karasburg	Okahandja	Outjo	Velloorsdrif	
Gansvlei	Karibib	Okahao	Rehoboth	Walvis Bay Airport	
GrOnau	Khorixas	Okakarara	Rosh Pinah	Wenela	
Grootfontein	Klein Manassa	Okaukuejo	Ruacana	Husea Kutako Airport	
Helmeringhausen	Leonardville	Omahenene	Sendelingsdrif		

TABLE 8.22	LEVEL 3 (SERVICE) DESTINATIONS - Nam				TABLE8.22
AiAis	Epukiro	Nkurenkuru	Oshivelo	Sukses	
Aminuis	Gibeon	Ogongo	Otjinene	Tsandi	
Arandis	Goageb	Okalongo	Palmwag	Uhlenhorst	
Asab	Gochas	Okamatapati	Rietooog	Witvlei	
Berseba	Hochfeld	Omafo-Engela	Schlip		
Bukalo	Kombat	Onesi	Sesfontein		
BOllspoort	Kongola	Ongandjera	Sesriem		
Dordabis	Mukwe	Ongwediva	Solitaire		
Drimiopsis	Mururani	Oshikuku	Stampriet		

TABLE 8.23	NO LEVEL ALLOCATED (LOCAL) DESTINATIONS- Nam				TABLE 8.23
Aasvoelnes	Kaisosi	Nakayale	Omeege	Rietfontein	
Abenab	Kalembesa	Nauta	Omega	Sangwali	
Andara	Kaliangile	Ncamakora	Omitara	Seeheim	
Aris	Kalkfeld	Ncaute	Ompundja	Sesheke	
Bagani	Kaoko Otavi	Ndonga	Omungwelume	Shamundambo	
Biro	Kasese	Nepara	Onaanda	Sheetekela	
Cape Cross	Katima Mulilo Airport	Nhoma	Onamundini	Shiguru	
Chetto	Katungu	Nyangana	Onathinge	Shinyungwo	
Chinchimane	Kayaru	Nyonda	Onayena	Shitemo	
Coblentz	Kayengona	Ohalngu	Onderombapa	Sibinda	
Dobra	Klein Aub	Ohakafiya	Ondimbwa	Sigeretti	
Elago	Koes	Oilyateko	Ondobe	Silenge	
Elim	Kongongo	Okambebe	Onelago	Siongo	
Elundu	Kosheshe	Okanjenedi	Ongenga	Steinhausen	
Endola	Kosis	Okankolo	Ongongo	Summerdown	
Epembe	Kubona	Okatana	Oniipa	Tallsmanis	
Etanga	Kuseka	Okatope	Oshifo	Tavauka	
Eunda	Linyandi	Okatuwa	Oshikwiyu	Tjeje	
Gam	Lisauli	Okaulukwa	Othijanjasemo	Terra Bay	
Goanikontes	Luhebu	Okombahe	Otjimbingwe	Tses	
Gove	Lusese	Okondjatu	Otjitanda	Tsintsabis	
Groot Aub	Matushe	Okongo	Otjituoo	Utokota	
Gross Barmen	Makena	Okovimburu	Otjijarwa	Uukango	
Guma	Mashari	Ombathi	Otjondeka	Vungu Vungu	
Hardap	Mayara	Ombombo	Otjosonda	Warmbad	
Helena	Mile 108		Otumborombonga	Wilhelstal	
Hoachanas	Mile 14		Ozondje	Wlotzkabaken	
Holoog	Mile 68				
lipandayamite	Mile72				
liwiyongo	Mpungu				
Jakkalsputz	Mukuvi				

Reproduced under Government Printers Authorization No. 11542 dated 7th July 2017



SOUTHERN
AFRICAN
DEVELOPMENT
COMMUNITY

VARIABLE MESSAGE SIGNS

SECTIONS

- 9.1 Introduction
- 9.2 Dimensions

MAY 2012



SADC RTSM - VOL1

CHAPTER

9

Reproduced under Government Printers Authorization No. 11542 dated 7th July 2017

CHAPTER 9: VARIABLE MESSAGE SIGNS

9.1 INTRODUCTION

9.1.1 General

- 1 The growing traffic congestion on sections of the road network, in combination with its ever-increasing complexity, requires that road authorities consider special management methods to control and optimise the use of the network. Such needs may exist in major metropolitan areas, on by-passes or on rural sections of roadway during peak holiday seasons.
- 2 Variable message road traffic signs may be used as a component of a Road Traffic and Safety Management System. The type of sign covered by the description VARIABLE MESSAGE SIGN varies extremely widely, from the well-known STOP/GO sign R1.5A/R1.5B, which is manually operated, to highly sophisticated, computer operated, gantry mounted fibre optic signs which offer the option of many different messages.
- 3 Economic considerations are often such that funding cannot be made available to build new roads. It becomes necessary as congestion develops that the best possible utilization is achieved from the road space available. In addition this will limit the environmental impact of a growing road network, and in cases where land is scarce, will allow a wider range of land use activities.
- 4 VARIABLE MESSAGE SIGNS can play an important role in the safe optimization of available road space whether it is in and around our cities, or on other sections of the network subject to operational break-downs due to bad weather, accidents or maintenance activities. In assessing the need for major variable message sign installations the economic considerations of not doing so must be thoroughly investigated. Roads, and in particular freeways, represent a major capital investment and the best return on this investment should be achieved.
- 5 Safety is undeniably of paramount importance, but although safety is obviously important from the point of view of relieving human suffering in the form of accidents, it also has major economic implications. On a national scale accidents and congestion cost vast sums of money. These costs occur in the form of damage to vehicles and public utilities and in hospitalisation, and in lengthy delays to thousands of people at a time. The less direct costs involved in providing emergency, ambulance, tow-away services and emergency traffic control together with the cost of administrative overheads add significantly to the national cost. Road traffic and safety management techniques aimed at reducing these costs are likely to produce worthwhile returns on the investment involved.
- 6 The harmonizing and stabilizing of traffic speed are vital factors in road safety. Harmonising traffic speed will increase the dynamic capacity of a roadway significantly and this is particularly important when the static capacity of the roadway has been reduced as a result of a lane closure due to an accident or roadworks. Drivers instinctively adjust their speed under adverse conditions. They will, however be unaware of conditions three or four kilometres ahead of them. If those conditions become unstable drivers are not able to react so as to maintain harmonious flow conditions. If a traffic control

management system is provided, however, advice can be given remote from the site of an incident location, which will allow harmonious flow conditions to be maintained.

- 7 As a general example, due to reduced headways required, a reduction in running speed by some 35% could result in 150% more capacity on a given section of roadway.

9.1.2 Objectives of VMS

- 1 The introduction of VARIABLE MESSAGE SIGNS should be aimed at achieving one, or more, of the objectives listed in the following paragraphs.
- 2 The primary objective should be greater safety, achieved by:
 - (a) reducing the risk of primary accidents;
 - (b) giving advance warning of conditions which may result in traffic queues so that the increased likelihood of secondary accidents is reduced.
- 3 The next major objective should be better utilization of road capacity and therefore a reduction in the cost of congestion by:
 - (a) distributing traffic more evenly in the road network;
 - (b) achieving stable traffic flow conditions;
 - (c) avoiding localised congestion resulting in long delays.
- 4 It should also be an objective to make the task of the police, road construction units and other authorities responsible for the safe use of the roadway easier by:
 - (a) providing the means for rapid and effective action for incident management;
 - (b) offering aids which will enable roadworks to be carried out more quickly and efficiently.
- 5 In addition when a sophisticated system is under consideration it should be designed to collect traffic data with the objective of:
 - (a) facilitating an assessment of the state of the system;
 - (b) using the data to assist decision-making in order to optimize use of the system;
 - (c) developing new strategies which can be used to amplify the system at a later date.
- 6 The achievement of these objectives will best be realised by designing the system to provide one or more of the following:
 - (a) a facility for advising a constant (normally reduced) speed in special circumstances e.g. . mist, fog, accident;
 - (b) detection of disruptions in traffic flow and translating this into warnings to reduce speeds;
 - (c) adequate warning of changes in road situation e.g. roadworks, maintenance etc.;
 - (d) the use of the system to close off a lane simply and clearly with the emphasis on simplicity and speed;
 - (e) by making it possible for the police to close a lane

and/or introduce speed controls in the event of an accident;

- (f) a flexible system of data collection and recording which allows for all forms of data to be collected simultaneously at a large number of points.

9.1.3 Applications for VMS

- 1 The number of applications for VARIABLE MESSAGE SIGNS in the traffic and transportation field is constantly growing. Typical of current applications are the following:

- (a) hazard warning;
- (b) speed regulation or advice;
- (c) specific vehicle routing (including bus lanes);
- (d) alternative routing;
- (e) road construction and maintenance;
- (f) lane control and reversal of lane use;
- (g) parking availability;
- (h) transport terminal information, both externally and internally.

- 2 Collectively these applications may be considered to come under the general description of Road Traffic and Safety Management Systems.

9.1.4 Types of VMS

- 1 The range of VARIABLE MESSAGE SIGN types is large. A number of examples of basic types are illustrated in Figures 9.1 and 9.2. The range in sophistication is also large and this is a factor which makes the selection of the most appropriate type for a specific task difficult. Ultimately the final decision is likely to be based on economic considerations and the more expensive installations must only be chosen after a comprehensive cost benefit analysis has been carried out. Due to the lack of direct Southern African experience of VMS's, it is likely that pilot projects will be required over a number of years to determine the ideal parameters for a comprehensive variable message sign traffic management system.

- 2 The sign types listed below will be covered in more detail in subsequent Subsections. The more commonly used types of variable message sign, from the simplest to the most complex, are:

- (a) manually operated (light reflecting) - Figure 9.1:
 - (i) rotating sign on a stand or easel such as the STOP/GO sign R1.5A/R1.5B;
 - (ii) flip sign;
 - (iii) hanging or clamped message;
- (b) electro-mechanical involving moving parts (light reflecting) - Figure 9.1:
 - (i) various combinations of roller blind or belt;
 - (ii) different arrangements of rigid plates;
 - (iii) rotating plank or prism;
 - (iv) matrix with rotating discs (*lamella*);
- (c) electrical or electronic with no moving parts (or a very limited number) (light emitting) - Figure 9.2:
 - (i) matrix of illuminated bulbs;
 - (ii) matrix of fibre-optic cones.

- 3 This volume does not cover details of the electrical characteristics of various types of variable message sign, however, a specific problem may relate to the use of such signs. The option to have a mains electricity supply in a rural situation will often not exist or will be prohibitively expensive. Considerable technological advances are occurring in the use of solar energy panels to maintain battery operated systems for long periods of time. Alternatively signs may be trailer mounted in conjunction with a portable generator. The possibility of using such power sources should be investigated in respect of potential rural installations.

9.1.5 VMS: Message Types

- 1 VARIABLE MESSAGE SIGNS may be used to transfer any of the traditional road traffic sign message types, namely:

- (a) regulatory;
- (b) warning;
- (c) guidance;
- (d) information.

9.1.6 Colour Code for VMS

- 1 Variable message sign types which do not require internal illumination can operate within the standard road traffic sign colour code without any difficulty.
- 2 Light emitting or internally illuminated electrical or electronic signs which are most likely to be of the matrix type, can, with existing levels of technology, illustrate symbols and text with acceptable legibility. However, the ability to provide a fully illuminated regulatory or warning sign background in WHITE, or BLUE for a PERMANENT sign or YELLOW for a TEMPORARY sign, in conformity with the Southern African road traffic sign colour code, whilst technologically possible, requires high electrical power levels. This requirement would, at present, rule out the use of battery or solar power, and if provided from a mains supply would be extremely costly.
- 3 In the interests of safety, and because of the conspicuity effectiveness of red at long range, the RED border shall be retained for circular PROHIBITION signs and triangular WARNING signs, when it is intended to enforce the prohibition message. If it is not intended to enforce such a message, the message should be given in an advisory manner as a text message commonly in association with a triangular warning sign indicating the reason for the advisory message. For practical considerations, however, all internally illuminated electrical or electronic variable message signs may use a WHITE or YELLOW symbol or text on a BLACK background.
- 4 Examples of regulatory, warning and advisory messages are given in Figure 9.3.1. Detail 9.3.1 illustrates two stages of a typical gantry mounted lane control VMS. These stages would normally be preceded by a default indication showing 80 km/h over all lanes, or, alternatively, a downward pointing arrow over each lane.

9.17 Manually Operated VMS

- 1 In order to realise the benefits of variable message signing in as many situations as possible the use of properly designed manually operated signs is recom-

- mended. In fact, if some warning or guidance message is not applicable at all times at a specific site an inexpensive manually operated sign should be used. The initial cost of such signs is unlikely to exceed two or three times the cost of a conventional warning (or regulatory) sign, however, there is a manpower requirement in seeing that the correct message is displayed at all times.
- 2 It is pointless utilizing a variable message sign if it is not going to be used properly. Road users will quickly notice if a sign is displaying the incorrect message and will ignore it on subsequent viewings, perhaps with extremely serious consequences. This in turn will bring the whole road traffic signing system into disrepute.
 - 3 Typical examples of manually operated variable message signs, which may commonly include as one of their two or perhaps three messages, a "NIL" message or blank signface, are :
 - (a) the STOP/GO sign R1.5AIR1.5B;
 - (b) various warning signs which ONLY have a temporary application, such as TRAFFIC CONTROL AHEAD sign TW304, SCHOLAR PATROL AHEAD sign TW305, ROADWORKS sign TW336, which may for reasons of convenience be permanently erected but displayed for a limited time, should therefore, when not relevant, have their message hidden leaving a blank sign face;
 - (c) this same technique may be used with certain SELECTIVE RESTRICTION signs which are applicable only for certain times of the day;
 - (d) some warning signs which have a "handed" message may be easily converted from a "left" side message to a "right" side message e.g. SURFACE STEP signs TW340 and TW341;
 - (e) combination warning and advisory messages, where the manual changing of a range of advisory messages may be expected. (The reason for the need for caution e.g., smoke, fog, flooding, etc., can be linked to an appropriate advisory speed, and perhaps the distance for which the condition may be expected can also be indicated.)
 - 4 Examples of manually operated variable message signs are included in Figure 9.1. (See Section 9.2 for dimensional requirements).
 - 5 Although such signs are simple in their operation it is recommended that in the case of the type covered in paragraph 9.1.7.3(e) a log of the number of alterations to the sign be kept. This data will be useful in justifying a decision to upgrade the sign to a more costly but more automated system.

9.1.8 Electromechanical VMS

- 1 Variable message signs of this type allow a wider variation in available messages from one sign face. The roller blind or be. could display a wide range of messages provided there is sufficient space to allow a long roller or be to be accommodated. Such a situation could be cost-effective at a toll plaza where segregation of vehicles by toll-class may be necessary. Normally if used at the roadside the number of messages will be limited to two or three, one of which may be a blank display.
- 2 Rigid plate, rotating shutter and rotating plank or prism signs are all likely to have a limitation on the range of messages. If the requirement is for a limited display

these types may be cost effective. These signs will normally also have a manual override capacity in case of a loss of power.

- 3 As the technology develops the use of matrices comprising two-state (bi-stable) display elements known as the "lamella technique" will become more attractive for road traffic sign messages. Each individual element in the matrix is electronically separately controlled. A short current impulse of about 350 ms is sufficient to turn the "lamellas" or discs. A very wide range of messages is possible and later developments with up to four faces per element may allow full colour display. Such systems have to be computer controlled and are extremely expensive on a unit rate (per m²) basis. However, with greater use, costs may come down to the extent that this sign type becomes cost effective. The sign type is widely used in USA and Canada, and in advertising.
- 4 Even in a normal environment this group of signs is likely to require regular maintenance. The ingress of water, dust or other foreign matter can cause break-down due to the often small spatial clearance between elements.
- 5 Manually operated and electromechanical variable message signs are light reflecting signs. As such they shall conform to the daytime luminance and night-time luminous intensity requirements laid down for standard signs.

9.1.9 Electrical or Electronic VMS

- 1 This type of variable message sign may be used for individual regulatory, warning or guidance signs, or for combinations of these categories of sign. Electrically or electronically operated matrices are most commonly used in comprehensive and dynamic real-time Road Traffic and Safety Management Systems.
- 2 Technological advances in light emitting components are tending to result in the replacement of matrices using illuminated bulbs by matrices using fibre-optics or LED's (light emitting diodes). The image definition achieved using fibre-optics or LED's and the luminous intensity of the display make these types of variable message sign extremely effective in all-weather conditions.
- 3 Examples of typical electrical and electronic sign matrices are illustrated in Figure 9.2, 9.4, 9.5 and 9.7.
- 4 The cost of electronic fibre-optic or LED signs is likely to be high, however, they are extremely reliable and relatively maintenance free. These characteristics may make them cost effective for relatively small installations.
- 5 Due to the high level of reliability and the common practice of providing duplicate light sources and partial operation, electronic systems can be designed which are extremely safe in that system security can be built in to give default modes of operation and battery power back-up.
- 6 Examples of approved symbols for use on regulatory and warning matrix variable message signs are illustrated in Figure 9.7. These symbols shall be used when regulatory and warning variable messages signs are to be used and the regulatory signs will be enforced.

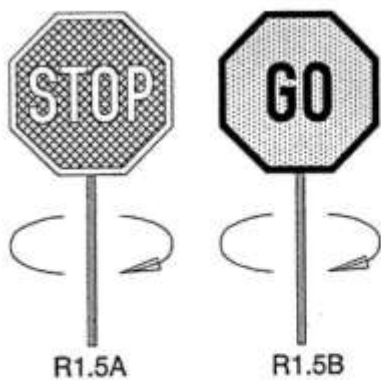

Detail 9.1.1 Back-to-Back Rotating Signs

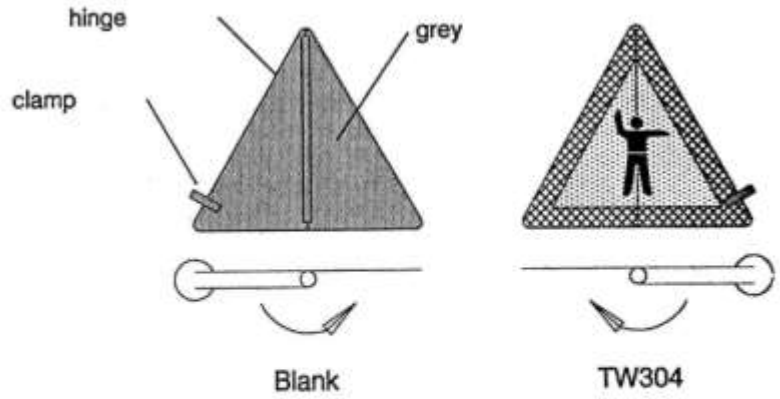

Detail 9.1.2 Flip Sign

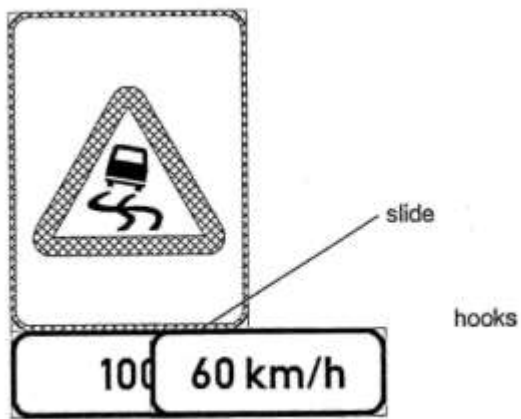

Detail 9.1.3 Slide Alternative

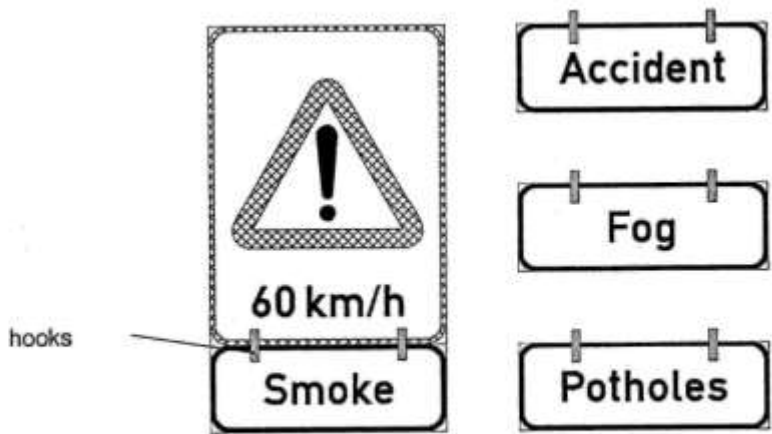

Detail 9.1.4 Hanging or Clamped Alternative

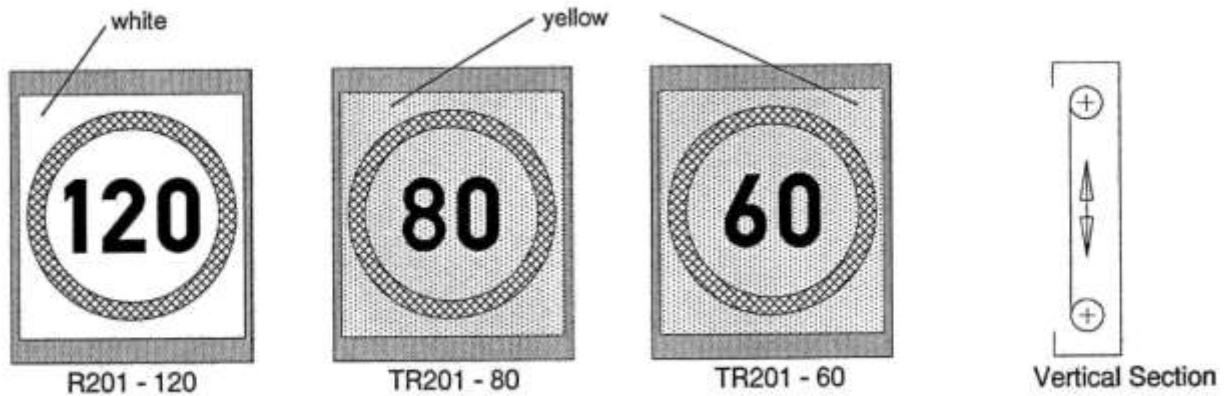

Detail 9.1.5 Roller Blind

Fig. 9.1 Manually Operated / Electromechanical VMS

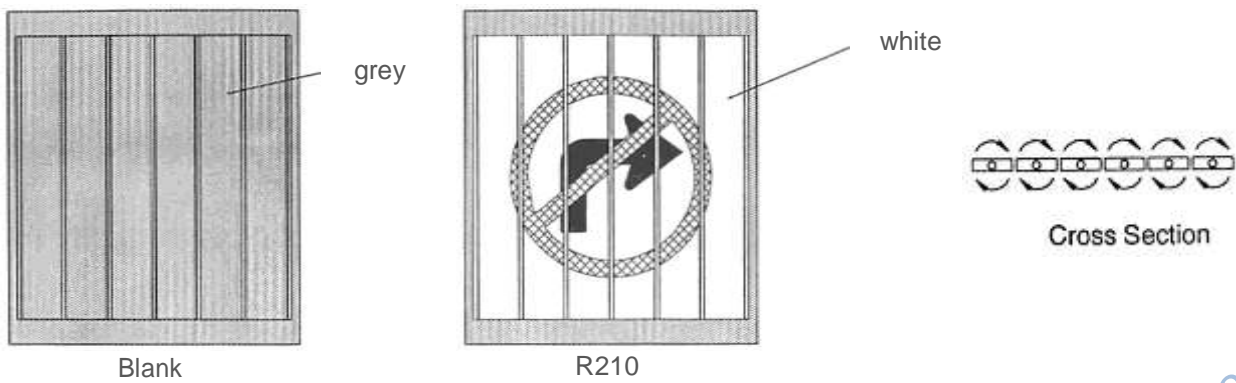

Detail 9.1.6 Rotating Plank - Two Message (including "Blank")

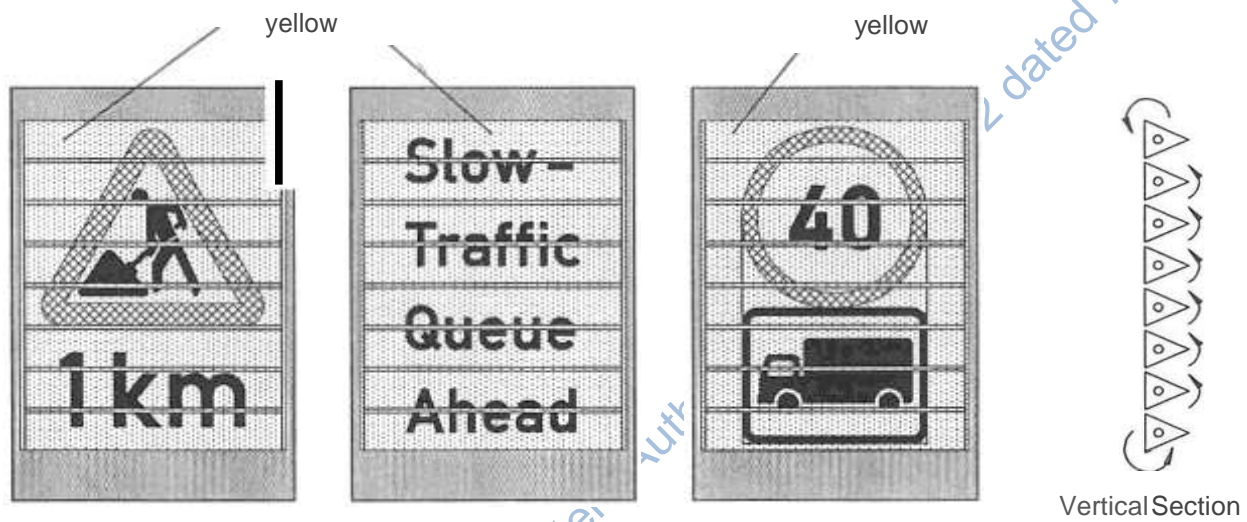

Detail 9.17 Rotating Prism - Three Message

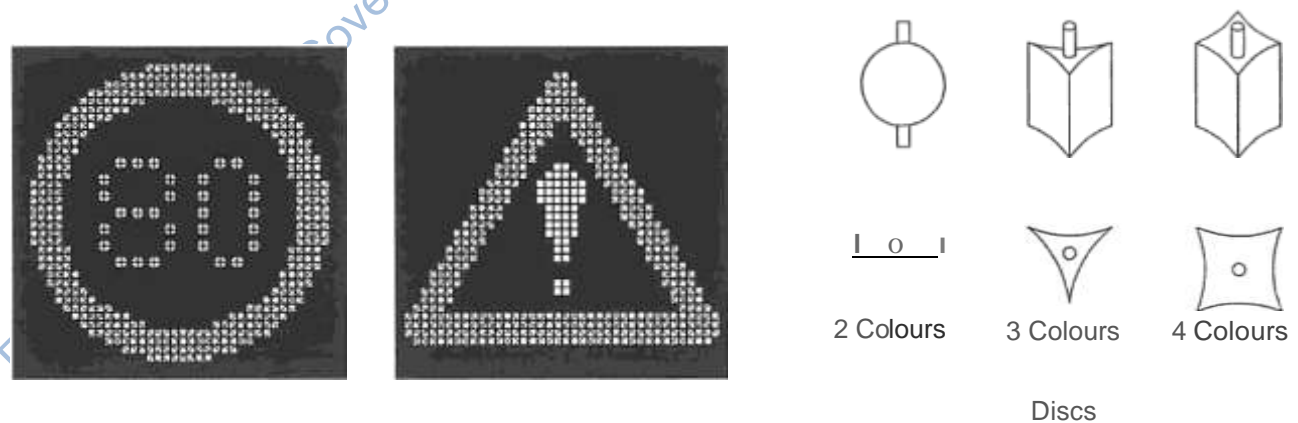

Detail 9.1.8 Matrix of Rotating Discs - Multiple Message

Fig. 9.1 Manually Operated / Electromechanical VMS

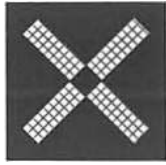

Detail 9.2.1 Overhead Light-emitting Lane Control VMS

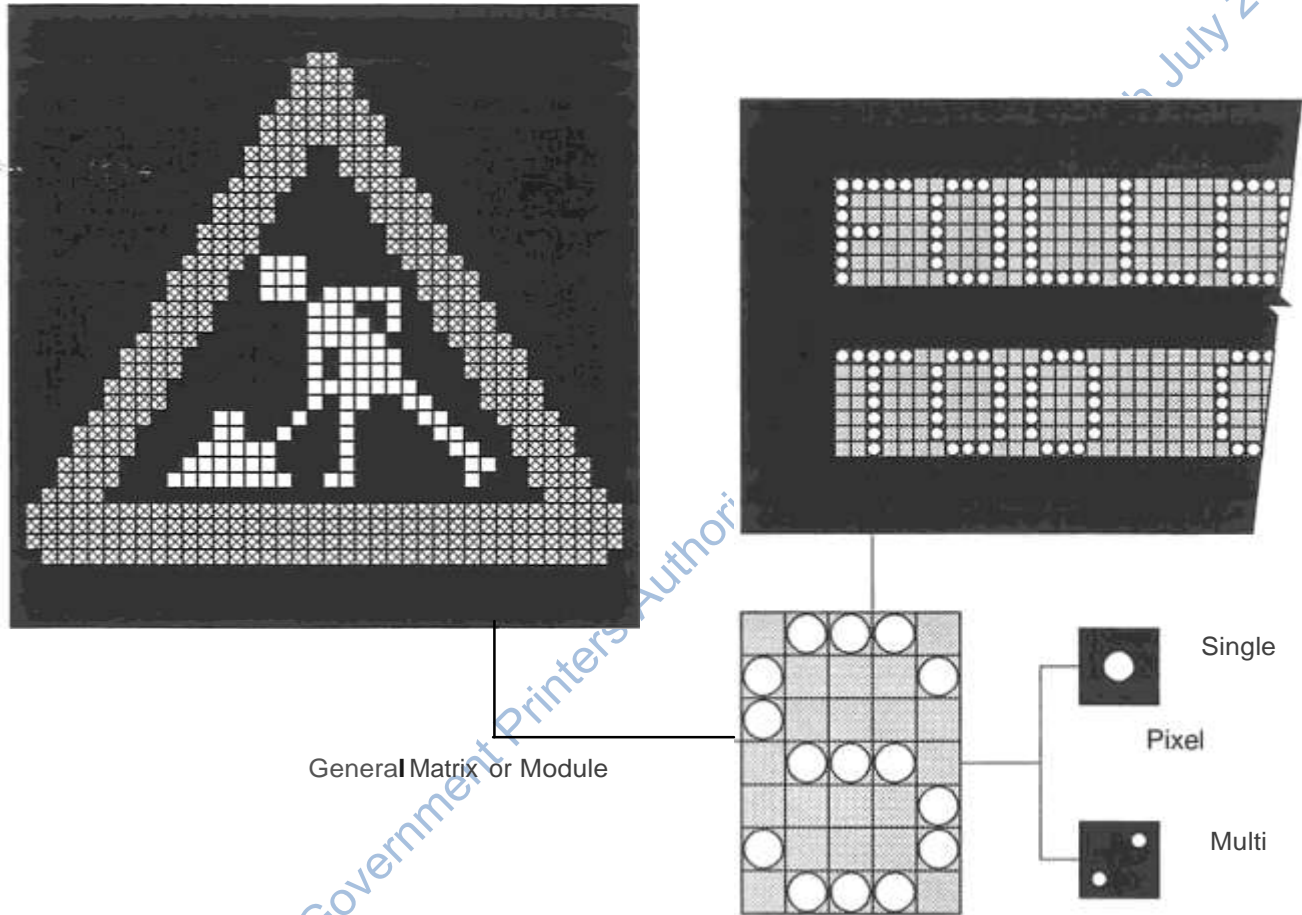

Detail 9.2.2 Text and Symbolic Light-emitting VMS

NOTES

1 The matrix principles illustrated apply for electromechanical, electrical or electronic VMS (see Chapter 10).

2 Text or symbolic signs may both be manufactured using a matrix either of filament bulbs, LED's or fibre optic cones. The matrix may be modular (letters) or cover the whole sign face.

Fig. 9.2

Electrical or Electronic VMS

9.1.10 Design Considerations for Electrical or Electronic VMS

- 1 The photometric and geometric (or dimensional) requirements for light emitting variable message signs are based on the following functional requirements, which are relevant to all road traffic sign design :
 - (a) conspicuity
 - (b) legibility;
 - (c) comprehensibility;
 - (d) credibility.
- 2 These aspects can be expressed in values of the required visibility distance provided details of the task and the observer population are known.
- 3 Messages may include symbols, numerals, and letters or words. These messages are normally ones to which the driver should adhere (regulatory) and react. It is common practice to supplement a regulatory or warning message with a measure of explanation. Parts of the message may be discerned individually as with numerals or as an entity with words or symbols. To be effective the message(s) must be perceived in time. Relevant factors in determining the "time" are:
 - (a) approach speed;
 - (b) sign content including type of message and amount of message;
 - (c) type of decision to be made by the driver;
 - (d) familiarity of message type;
 - (e) experience, motivation, age and visual capability of observer.
- 4 These factors are common to all road traffic sign design requirements. In general, in view of the large potential for variation in the different parameters, it is likely that it will be difficult to obtain meaningful local data relevant to the various variable message sign design parameters.
- 5 A number of overall values relevant to electronic variable message signs can be given which serve as practical guidelines, however. These are:
 - (a) the type of message i.e. regulatory, warning or guidance should be clearly recognisable from a distance of at least 200 m;
 - (b) essential messages, such as speed limit value or other legend must be clearly legible from a distance of at least 150 m;
 - (c) the light intensity of the optical signal should be adaptable to ambient brightness and a night-time mode should be offered;
 - (d) should the principal light source fail, a back-up bulb should come into operation in such a way that the essential characteristics of light intensity, visibility etc. are not affected;
 - (e) the system should be designed so that the sign is visible from a distance as close as 35 m, even when approached from a wide angle of vision.
- 6 The values given in paragraph 9.1.10.5 are relevant for freeways, major rural roads, or urban arterials. The likelihood that a variable message sign will be used, say in a residential environment, is limited. If sight distance falls below the recognition or legibility distances given, the use of an additional sign should be considered.
- 7 Experts consider that there is a sufficient influence of regional factors, such as ambient light, population characteristics and available technology that it is premature to prescribe a standard alphabet and set of symbols for use on dot matrix variable message signs. A set of 7 x 5 character matrices for upper case letters and for numerals is illustrated in Figure 9.4 and is recommended for development purposes. Other standard characters and limited matrix details are given in Figure 9.5. Typical symbols are illustrated in Figure 9.6.
- 8 The internal and external dimensional requirements for electrical and electronic VMS are not fully developed for Southern African conditions. Basic guide-lines are given in Section 9.2. Research is needed in this respect as experience of installations, particularly in Europe, is tending to indicate that the letter shape ratio may be better for matrix signs if it tends towards a height to width ratio of 2 to 1, rather than the presently used ratio of 7 to 5. There are also indications that letter spacings need to be greater than those given by DIN 1451 for use with conventional retroreflective letters (see Figure 9.6).
- 9 Light emitting matrix signs consist of a large number of dots or separate light units. In order that the observer can perceive the intended message these dots or light units must be seen both as a continuum when required and as separate entities when required. To achieve this, the spacing of certain of the dots must be less than a certain value and the separation of others greater than another value. Acceptable limits for these values depend on the conditions of observation, the characteristics of the observer, and all other factors mentioned earlier in this Section. The most important two factors are, however, the luminous intensity of the individual dots or light units and the background or adaptation luminance (see Figure 9.6).
- 10 The manner in which variable messages are switched is likely to affect the comprehension and credibility of VMS. This factor, although applicable to the switching of symbolic and text messages, will have a greater effect on the quality of a text message, particularly a relatively long one. If a number of text messages are to be given a driver is only likely to be able to read one message per sign, unless the messages are very short indeed. A number of signs may therefore be required if several messages have to be transmitted. A specific message must also be in view for sufficient time to allow a driver to read it. The reading time details given in Chapter 4 are relevant to this VMS design parameter. When a message is changed it may be changed totally in one operation or in a "flowing" movement. Many VMS requirements may appear similar to switchable advertising signs. Designers are cautioned against using advertising techniques without careful consideration of the road sign message transfer requirements. Although not substantiated the "flowing" switching movement appears more aesthetically acceptable. If the flowing movement of the change is from left- to- right and top- to- bottom (for larger messages in two lines) a reader will have the first message in view for a maximum reading period.
- 11 The quality of a light emitting variable message sign depends on:

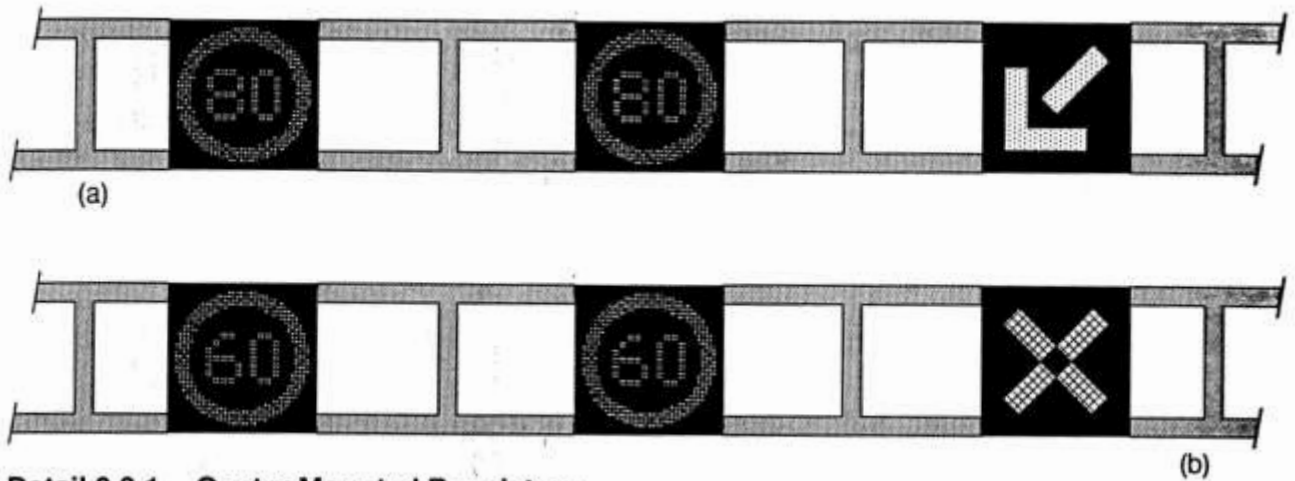

Detail 9.3.1 Gantry Mounted Regulatory VMS

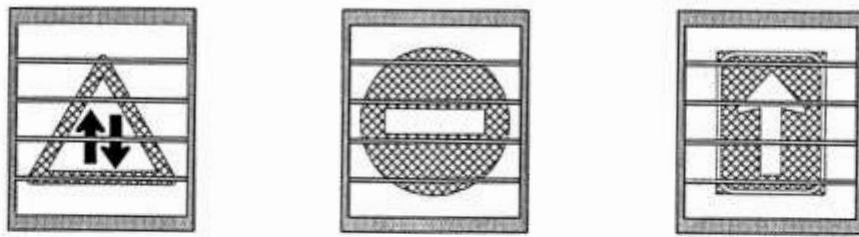

Detail 9.3.2 Regulatory / Warning VMS

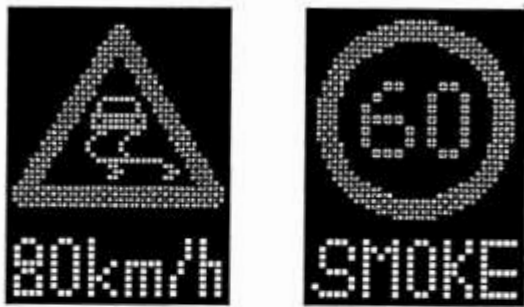

Multiple message capability

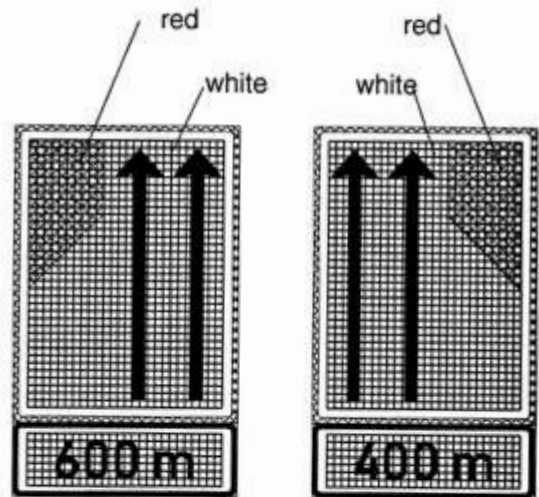

Only changing area provided with discs

Detail 9.3.3 Warning / Regulatory VMS

Detail 9.3.4 Guidance VMS

Fig. 9.3 Typical Regulatory, Warning, Guidance and Information VMS

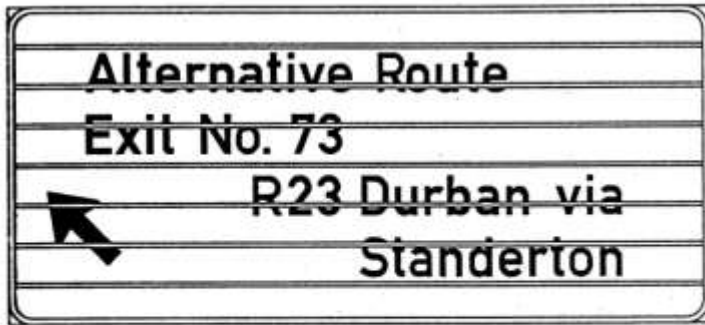

Detail 9.3.5 Guidance - Direction VMS

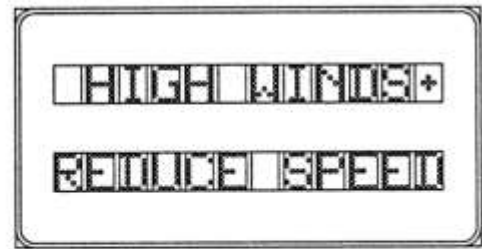

Detail 9.3.6 Information VMS

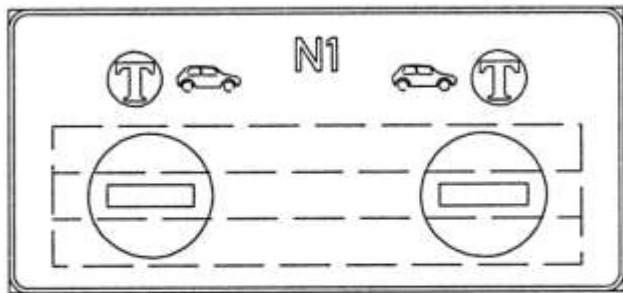
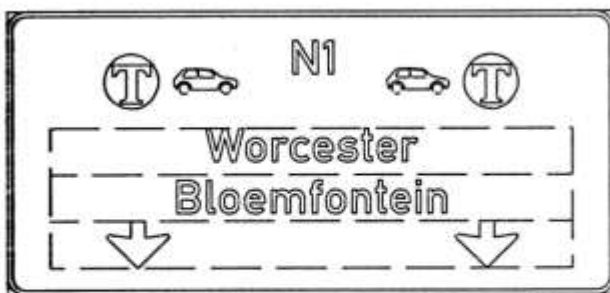

Detail 9.3.7 Regulatory / Guidance Combination VMS

Detail 9.3.8 Combinations

Multiple arrangements of Regulatory, Warning and Information possible

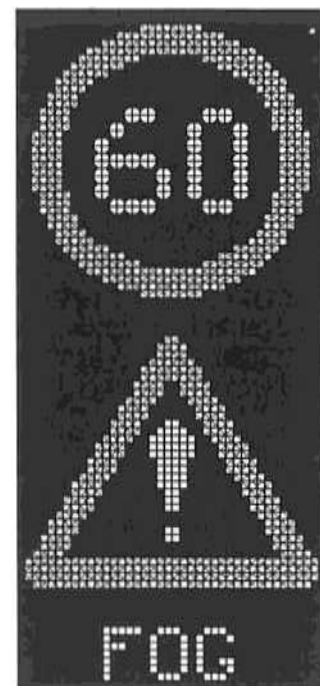
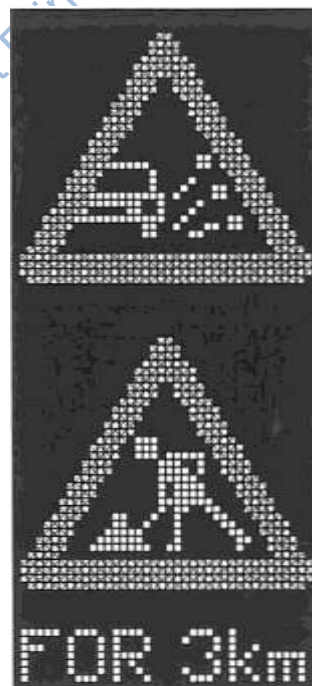

Fig.9.3 Typical Regulatory, Warning, Guidance and Information VMS

- (a) light intensity and viewing angle (widely variable according to sign type);
- (b) uniformity of illumination;
- (c) contrast between the light emitted and the ambient light conditions;
- (d) colour.
- 12 Available research is not conclusive on the best method of specifying performance for light emitting variable message signs. Specification may be made in terms of luminance or luminous intensity for individual light components or for the sign as a whole. For practical purposes the luminous intensity for white characters should be between 600 candela and 1000 candela for day operation, and between 60 cd and 100 cd for night-time operation. The values for red parts of a sign should be between 400 cd and 600 cd during the day and between 40 cd and 60 cd at night. It should be noted that light intensity values of 3800 cd can be obtained on the light axis of fibre-optic units. Losses will reduce this value substantially for the observer but it should also be noted that low values of luminous intensity reduce visibility of a sign whereas high values not only reduce legibility as a result of irradiation, but may also cause glare. As a general rule night-time intensity should be approximately one tenth of the daytime value. However, under bright Southern African sunlight conditions very high ambient light levels occur. In order to achieve adequate contrast levels during daytime the luminous intensity values may need to be significantly higher than those given above, whilst the night-time values will still apply. The day/night intensity ratio will increase under such circumstances. European research has indicated required contrast ratios between the light emitting component and bright ambient conditions in the range of 7-to-1 to 50-to-1. Southern African ambient light levels could require higher ratios. The numerical values given are for illustration purposes only because the actual values achieved are dependent on the number of light units illuminated and on the stroke width of characters. (For further details refer to Volume 2, Chapter 19: *Variable Message Signs*).
- 13 Visible differences between individual illuminated light units can negatively affect the legibility of a sign or even lead to the misinterpretation of the message. The following guideline can be applied to all fibre-optic systems including those using larger diameter light units. The formula takes into account the interdependence between the number of light points and the clarity/definition of a sign.

I_{average} should be between 0,7 and 1.3.
I_{sample}

where:

I_{average} is the average light intensity per light unit for all the elements within one sign of the same colour.

and:

I_{sample} is the average light intensity per light unit for a random sample of points on the sign (a 10% sample is a valid sample size).

- 14 Good legibility is especially dependent on the contrast between the message, the sign background and the ambient background to the whole sign. Elements of

character design have been covered, however, when designing fibre-optic signs, it must be remembered that lines of light points appear larger than painted or externally illuminated lines. It is possible to achieve adequate contrast for alpha numeric characters using only one row of light points. Such thin lines of high intensity light will be more clearly perceived by the eye than lines made of double rows. This effect must be compromised with the design requirement to have a back-up system whereby either an additional light source is automatically illuminated when the principal one fails, or a double row of light points is illuminated by two light sources which, on failure of a source will leave one row of light points illuminated. The use of double rows of light points is recommended if fibre-optic signs are used to create LANE DIRECTION CONTROL SIGNALS S16 (Green Arrow) and S17 (Red Cross). The recommended spacings of light points for various colours are given in Table 9.1 in Section 9.2.

- 15 To improve the contrast of a sign against a distracting ambient background such as the light of a clear sky or other illuminated features such as street lights or advertising hoardings a minimum sign background clearance to any character of 1,1 times the letter height in use is recommended.
- 16 Colour rendition from fibre-optic signs is achieved by use of colour filters. Colours produced by variable message signs should conform to the requirements given in Section 1.5 according to Figures 1.11 to 1.14 - *Chromaticity Chart for Colours for Road Traffic Signs*. It should be noted that colour filters result in a loss of light output which must be taken into account when calculating specific light intensity requirements.
- 17 Phantom luminance should not exceed 10% of the luminance of the sign symbols for an illuminance of 104 lux.
- 18 Matrix signs are commonly used on high speed roadways and are often placed in a regular sequence for lane control or gradual speed reduction purposes. A wide beam of emitted light is not required under these circumstances. Fibre-optic signs utilize optical cones at the signface to control light intensity and direction. Three types of cone are currently available
- (a) 6° cone –
 designed for high speed approaches with a light intensity on axis of 30 cd per point. The highest output levels occur at + or - 3°;
- (b) 14° cone-
 designed for intermediate approaching speeds with a light intensity on axis of 19,5 cd. The highest output levels occur at + or - 7°;
- (c) 24° cone-
 designed for low approaching speeds with an intensity on axis of 6,5 cd. The highest output levels occur at + or - 12°.
- 19 Variable message signs using dot matrix components need to be built into a housing which has certain characteristics. These characteristics apply to complete signs or modular units and include:
- (a) the ability to dissipate heat by adequate ventilation;
- (b) ease of access to replace components;
- (c) a front screen to protect the light units should have anti-reflection qualities (slight curvature has also been found to help reduce condensation within the housing);

- (d) tightly fitting components to eliminate ingress of water or dust (including filtration and protection of ventilation areas);
 - (e) internal surfaces a matt or semi-matt dark colour to avoid internal light reflection and interference.
- 20 The total light intensity of a fibre-optic sign is the sum of the light intensities emitted by the individual light points forming the signal. The total intensity depends on the following criteria:
- (a) the number of bulbs;
 - (b) the use of a beam splitter;
 - (c) luminous flux of the bulb;
 - (d) efficiency with which light is channelled from the source to the individual light unit (cone)
 - (e) light transmitting properties of filters;
 - (f) the number of fibre-optic cables or arms;
 - (g) the length of the fibre-optic cables or arms in a harness;
 - (h) the optical characteristics of the cones;
 - (i) light transmission loss due to the front screen.
- 21 The total light intensity can be calculated from the formula for symbols of a single colour (a separate calculation should be made for each colour):

$$I_{TOTAL} = n \times I_{LP} \times F_F \times F_{SC} \times F_B \times F_L \times F_A \times F_C \times F_{AN} \times F_{FS}$$

where:

- I_{TOTAL} = total luminous intensity of the symbol
- n = number of light points
- I_{LP} = light intensity per single light point
- F_F = correction factor for the filter
- F_{SC} = correction factor for the safety circuit
- F_B = correction factor for the bulb
- F_L = correction factor for the harness length
- F_A = correction factor for the number of cable arms in the harness
- F_C = correction factor for the cone type
- F_{AN} = correction factor for the viewing angle
- F_{FS} = correction factor for the front screen material

- 22 In an alternative form this formula may be used to determine minimum number of light points required for a given symbol or message. The correction factor "F_A" for the number of cables or arms in the harness

is omitted because the value of total light intensity specified, "I_{TOTAL}", will be a minimum requirement. Where "n" is the minimum number of light points required to produce the specified total luminous intensity:

$$n = \frac{I_{TOTAL}}{I_{LP} \times F_F \times F_{SC} \times F_B \times F_L \times F_C \times F_{AN} \times F_{FS}}$$

- 23 The testing of the design of a matrix sign should be done using standard measuring methods and equipment. Until such time as specifications are well established, new designs should be tested under representative traffic conditions by comparison with a "standard" sign. The following points should be borne in mind during testing:
- (a) when assessing "visibility distance" as a variable, the light distribution, the angle subtended, and the atmospheric transmission characteristics must be taken into account;
 - (b) the comparison must involve a large number of observers performing a realistic task;
 - (c) the test should call for identification of signs and recognition of their components.

9.1.11 VMS and Road Traffic and Safety Management

- 1 Dynamic real-time traffic control can be achieved by designing an integrated computer operated intelligent system incorporating variable message signs.
- 2 Sections of roadway experiencing unacceptable levels of congestion and accident rates and therefore high user costs, may warrant such a system. Although the capital cost is likely to be high the benefits to be achieved can be cost-effective.
- 3 Comprehensive systems have been developed in Europe and the Americas which operate automatically with no need for manual intervention. Such systems are capable of detecting incidents, congestion, and even weather conditions. Components of such a system are illustrated in Figures 9.8 to 9.10.
- 4 Figures 9.8 and 9.9 shows diagrammatic representations of how variable message signs fit into a typical road traffic and safety management system. Also illustrated is a schematic arrangement of detectors, detector stations, outstations and sign gantries.
- 5 Figure 9.10 shows schematically how computerised control may be applied through the use of variable message signs.

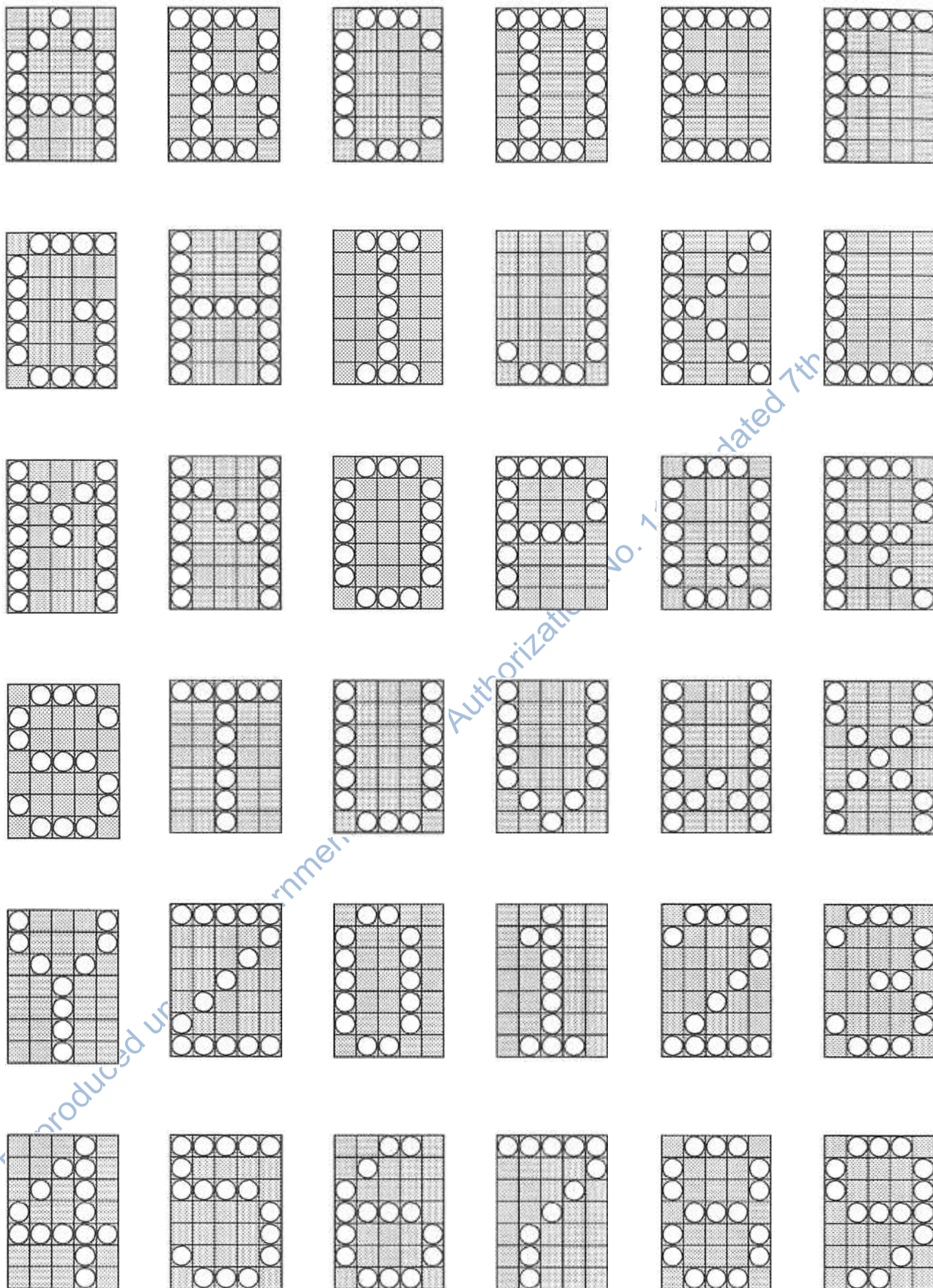
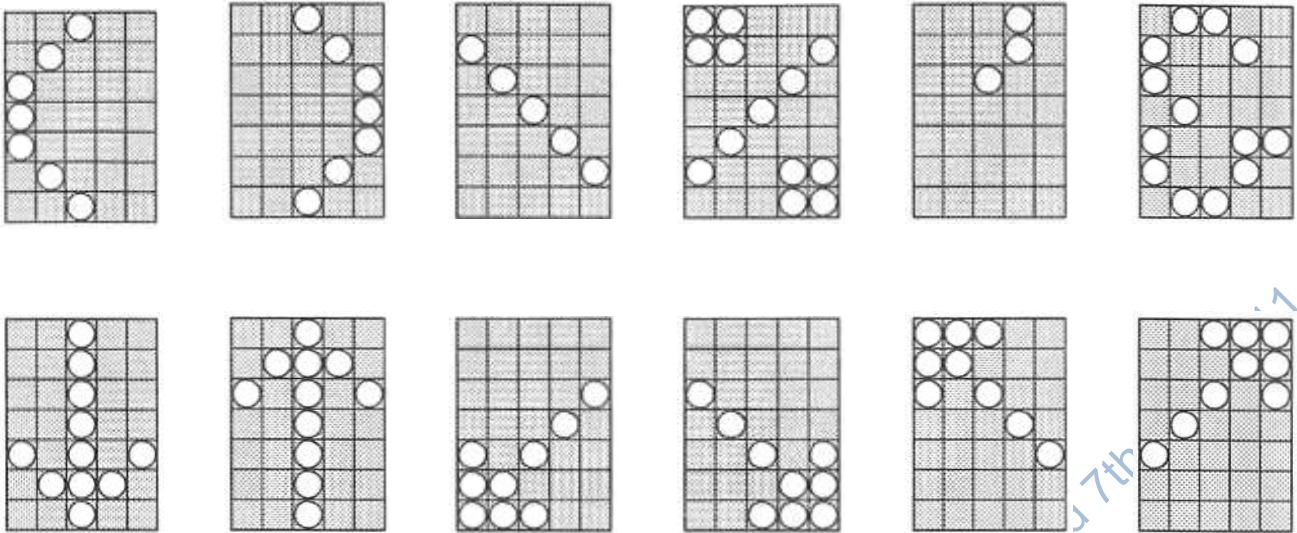
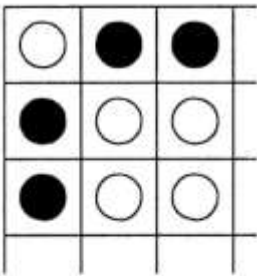

Fig. 9.4 7 - Character x 5 - Character Letters and Numerals



9.5.1 Other Selected Characters on Modular Base



9.5.2

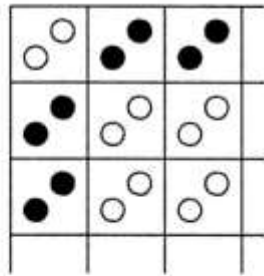

9.5.3

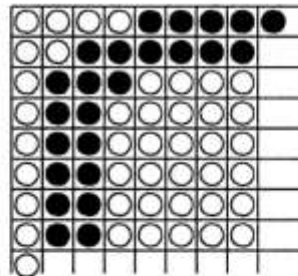

9.5.4

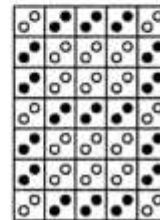
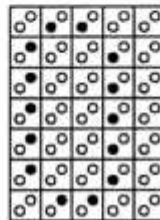
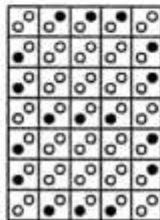
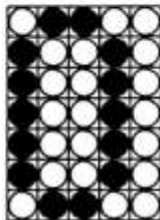
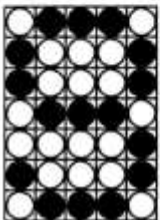

9.5.5 Effects of Bulb Failure - Example Numeral "8"

NOTES

- 1 In Figure 9.4 and Detail 9.5.1 all elements can be illuminated - those required for each letter are indicated by a circle.
- 2 Details 9.5.2 to 9.5.4 show large and paired small illuminated bulbs, and fibre optic elements respectively.

- 3 Detail9.5.5 shows the effects of bulb failure. The small element normally has a dual circuit.

Fig. 9.5 Further Details of 7 x 5 Character Matrices

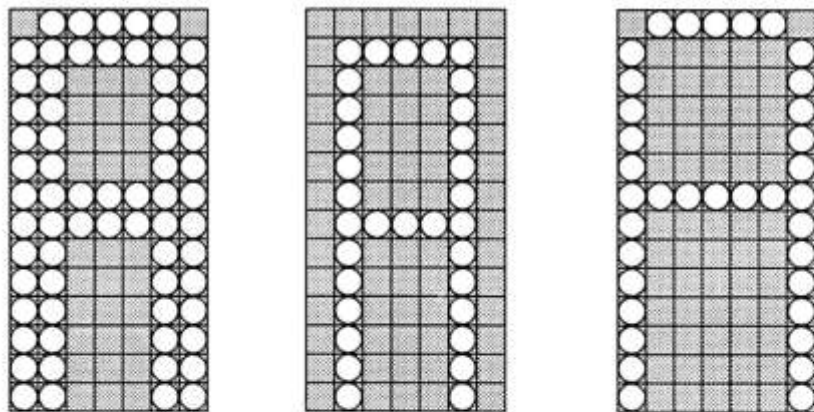

This matrix with a height to width ratio of 2 to 1 may offer better letter shapes and legibility. A dual circuit may also minimise effects of bulb failure.

Fig 9.6.1 Alternative Letter / Numeral 14 x 7 Character Matrix

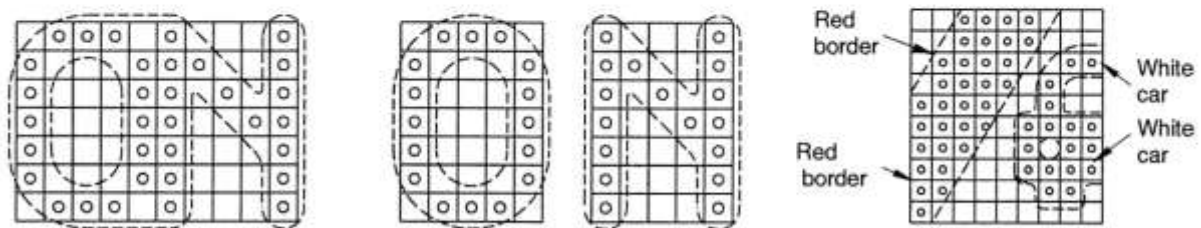
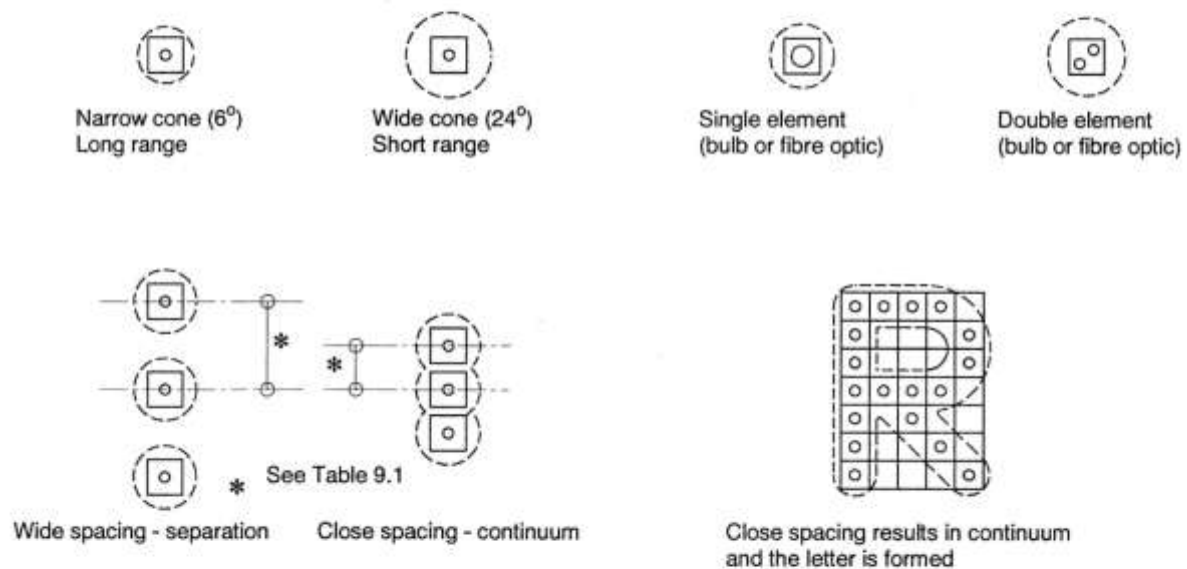

Examples of the design requirement; sometimes for a continuum and sometimes for separation.

Fig 9.6.2 Effects of Light Source Spacing

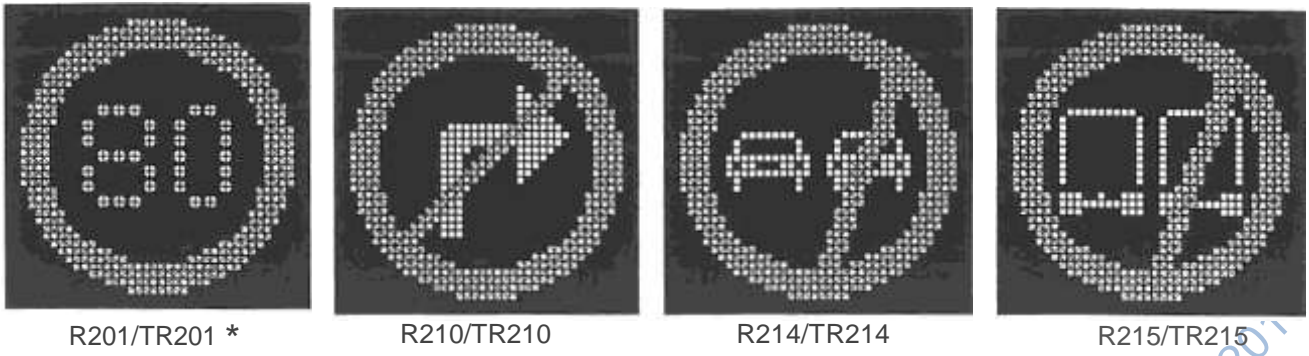

Detail 9.7.1 Regulatory Sign Symbols (Prohibition)

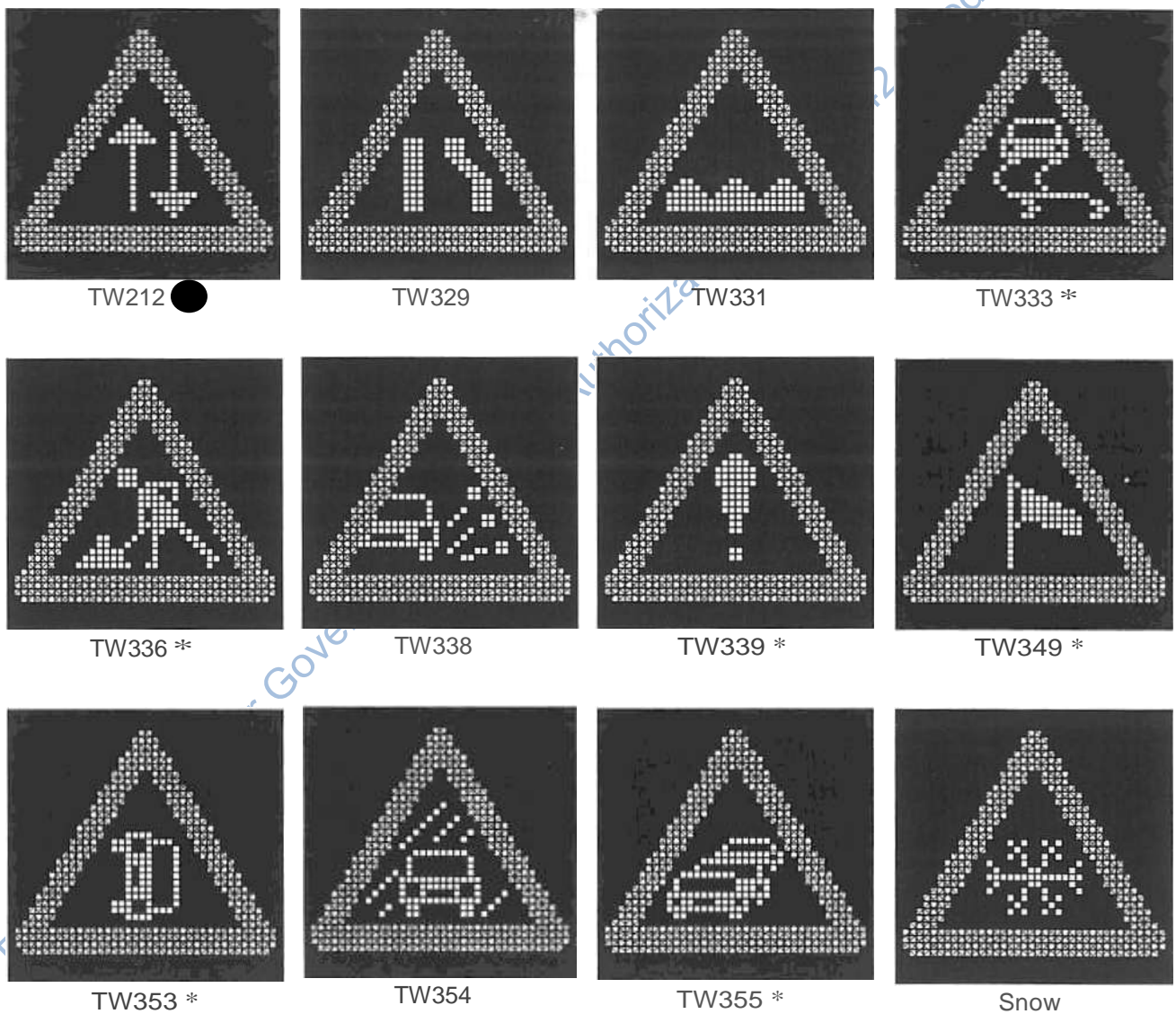

Detail 9.7.2 Warning Sign Symbols

* International

● See Chapter 3, Section 3.7 for variations appropriate to individual countries.

Fig. 9.7

Symbols

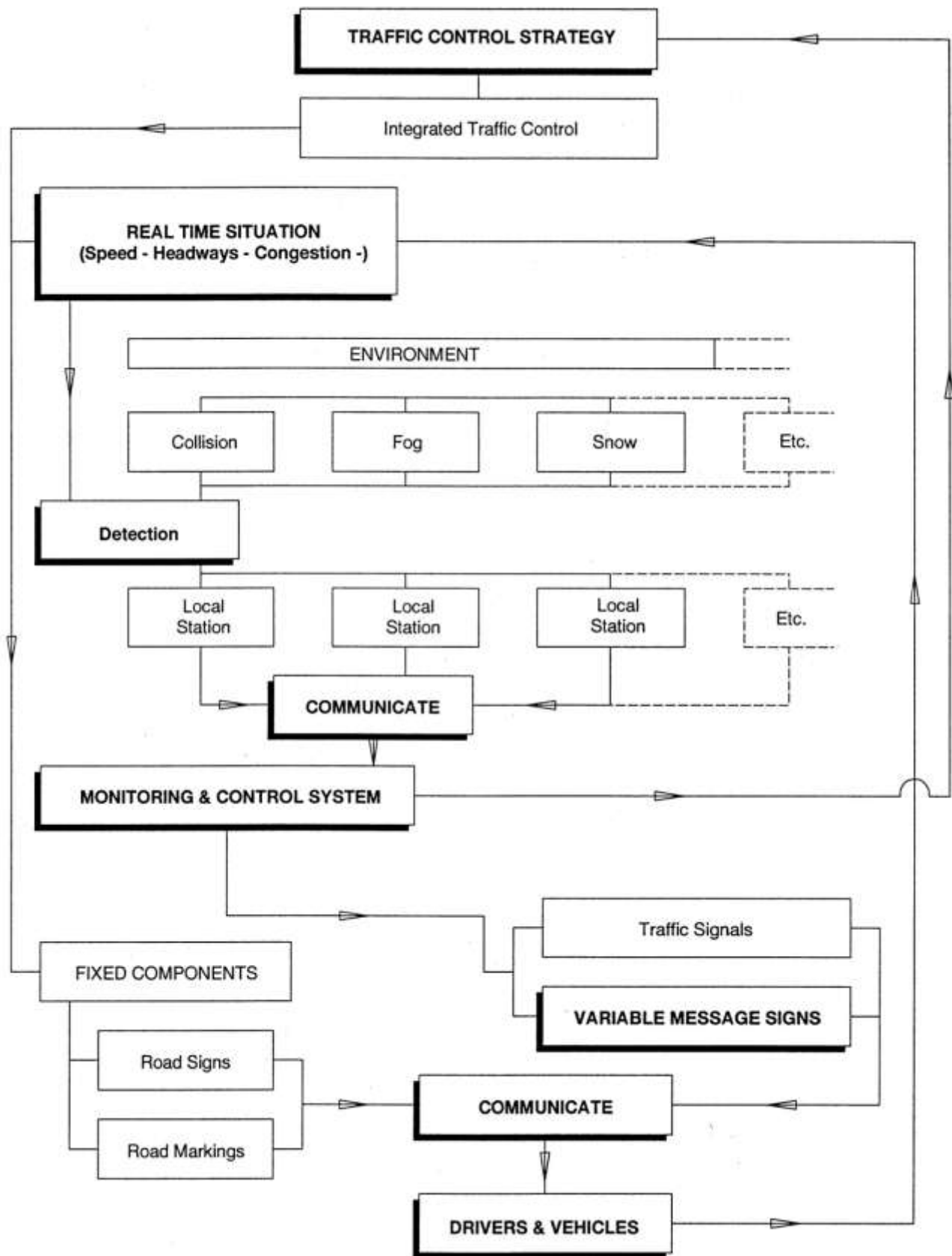
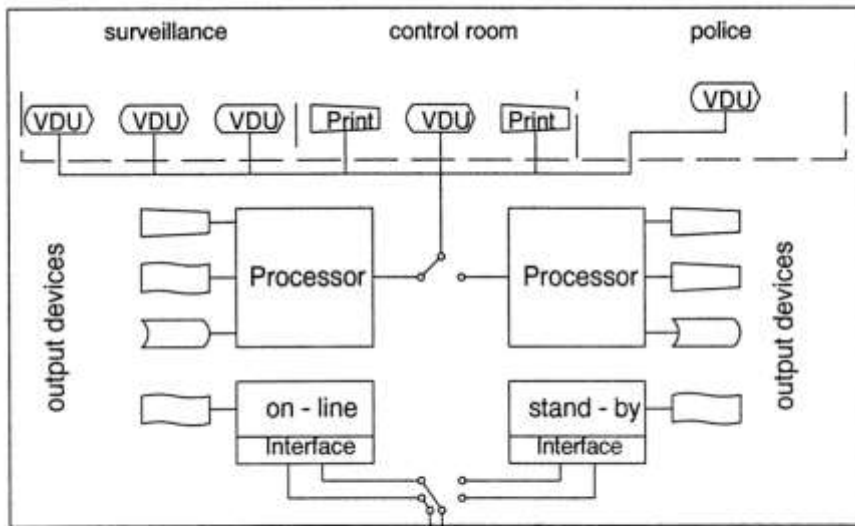

Fig. 9.8 VMS in a Road Traffic and Safety Management System



CONTROL CENTRE

To/From roadside equipment

ted 7th July 2017

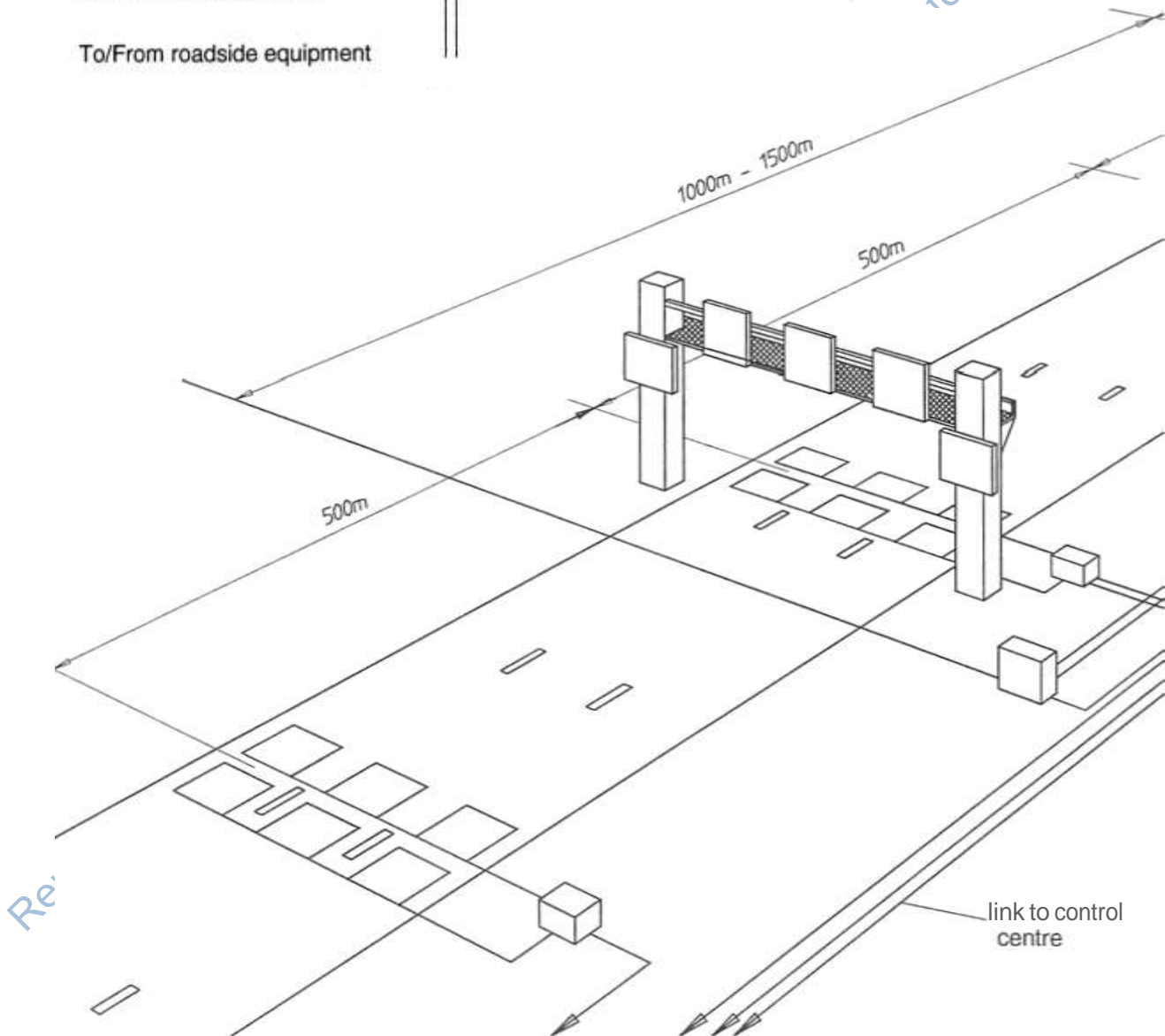

Fig.9.9

Typical Components of a Freeway Control System

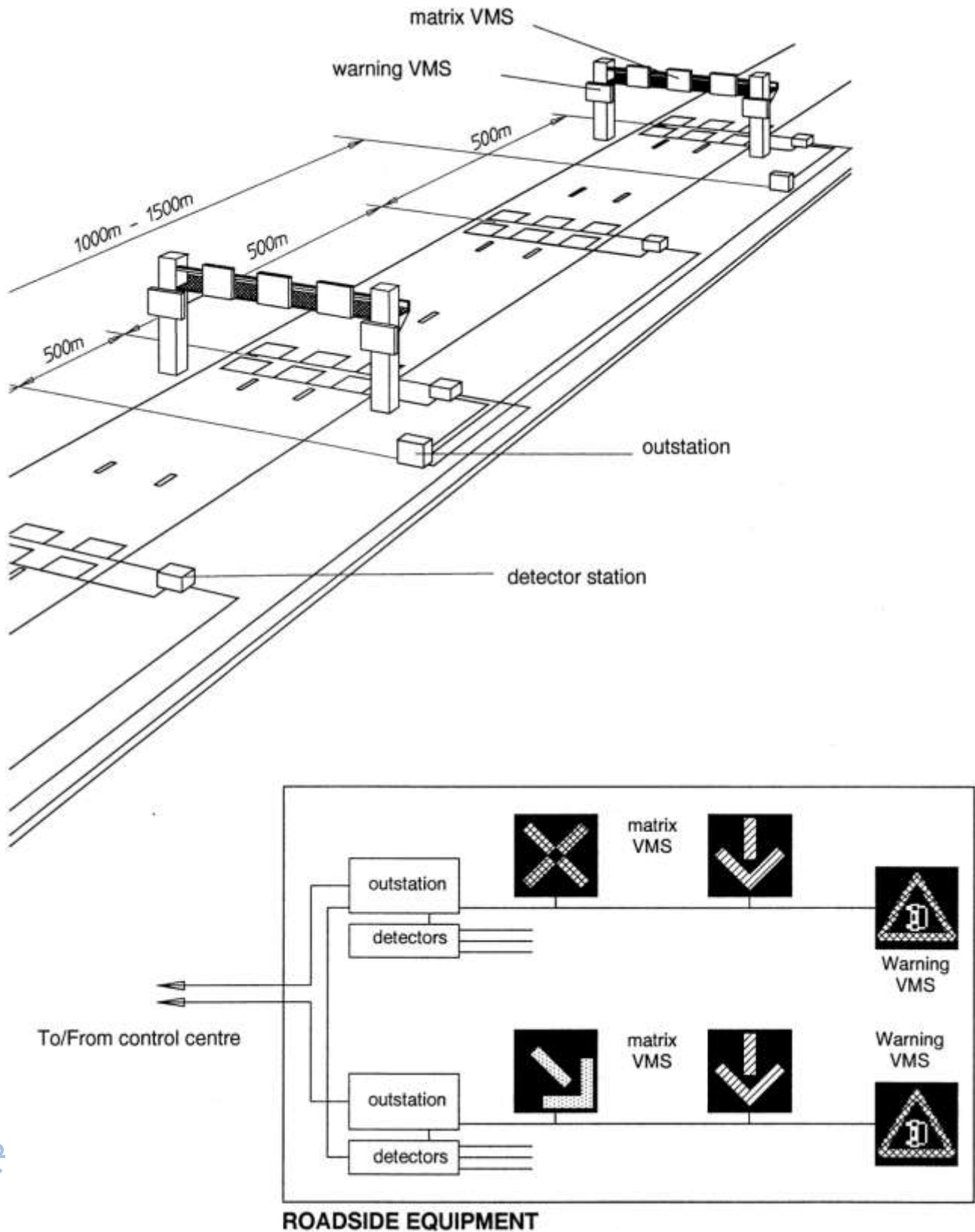

Fig.9.9 Typical Components of a Freeway Control System

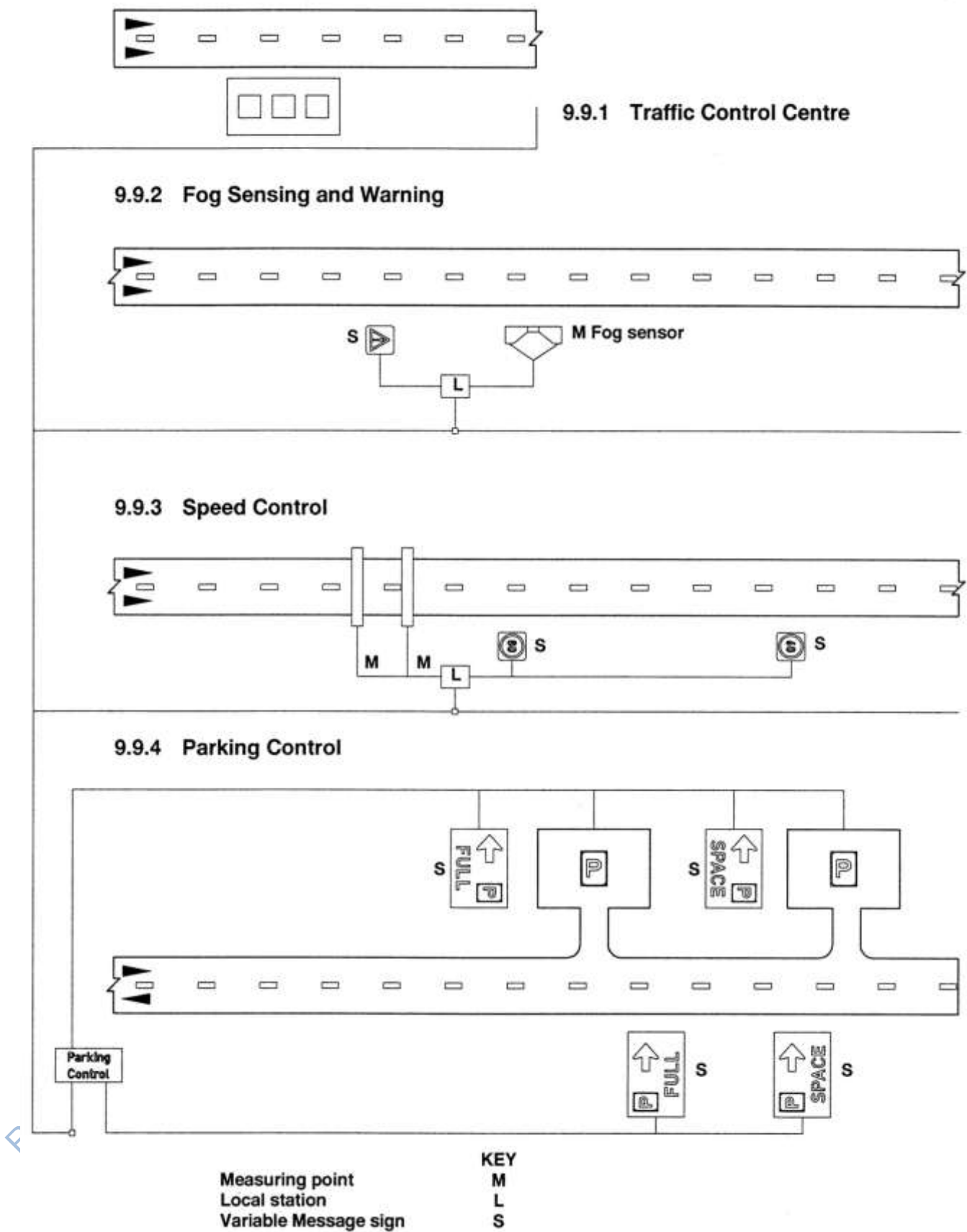

Fig. 9.10 VMS Applications in Road Traffic and Safety Management

Reproduced under Government Printers Authorization No. 11542 dated 7th July 2017

9.2 DIMENSIONS FOR VMS

9.2.1 General

- 1 As has been stated in previous Subsections the design of variable message signs is in a developing stage world-wide and although standards are being developed by the CIE (International Commission on Illumination), these are not yet universally accepted. The number of installations of light emitting VMS in Southern Africa, from which local knowledge may be gained, is, at the time of publishing, very limited. Full dimensional details are therefore not given in this chapter or in Volume 4 at this time.
- 2 The matrix details given in Figures 9.4 and 9.7 should be considered to be guidelines only although they are based on UK and European practice. The high ambient light levels common in much of Southern Africa are likely to require modification or extension to any European based standard. Such modification is likely to affect dimensional criteria.
- 3 Until such time as local research indicates otherwise any regulatory or warning sign provided as part of a light reflecting or light emitting variable message sign shall conform to the diameter or side length dimensional requirements for standard regulatory or warning signs given in Tables 2.4 and 3.1.

9.2.2 Light Reflecting VMS

- 1 The dimensions of any manually operated or electro-mechanical light reflecting VMS depicting a regulatory or warning sign shall conform in all respects to the dimensions appropriate to standard regulatory and warning signs given in Volume 4.
- 2 It will be common for such signs to be contained within a frame or background. The dimensions of such a background should relate as closely as possible to those used for HIGH VISIBILITY signs.
- 3 Similarly light reflecting VMS guidance and information signs should conform to the dimensional requirements given in Volume 4.
- 4 If a combination of standard and light reflecting VMS, or light reflecting and light emitting VMS, is required, it may be necessary to increase certain internal sign spacings to accommodate structural or mechanical aspects of the message changing mechanism.

9.2.3 Light Emitting VMS

- 1 The dimensions of arrow or cross VMS mounted over individual lanes as part of road traffic and safety management control installations shall conform to those given in Volume 4, Chapter 10 for LANE DIRECTION CONTROL signals S16 to S19. It should be noted that signals S16 to S19 may be identical in appearance to changeable arrow and cross signs, but the signals have a specific function and shall be used in a specific manner (see Chapter 6). Changeable arrow and cross signs may be used as S16 to S19 signals provided they conform to the functional requirements for the latter. They may also be used for other forms of lane use control not involving the DIRECTIONAL, or reversible use of lanes.
- 2 The effectiveness of letters, numerals and symbols used on light emitting VMS will be dictated by the physical components of the matrix used. Factors which

will influence this effectiveness are covered in Subsection 9.1.10. An acceptable visual definition must be achieved by all aspects of a sign. As a general rule the greater the detail required the closer or smaller should be the elements of the matrix used (see Figure 9.6).

- 3 A matrix may be produced by using off-the shelf modular components or by building up a customised matrix from the individual illuminated components such as bulbs or fibre optic cones. In the case of the modular components, normally forming letters and numerals, the spacing of the bulbs or cones will have been determined by the manufacturer. The 7 x 5 character matrix is not ideal for lower case lettering; therefore, variable message guidance and information signs using a 7 x 5 matrix should use only upper case letters. The use of letter matrices with fewer than 7 vertical components is not recommended. The spacing of the letters to form a word and the spacing between words, both horizontally and vertically needs to be confirmed for Southern African conditions. Figure 9.11 illustrates the basic dimensions used in the DIN 1451 lettering system for standard guidance signs. If a sign is subject to high ambient light levels the outer spaces should be increased from "5d" to "8d" and "6d" to "8d". The between line spacings may be reduced to a minimum of "3d" due to the fact that the signs use only upper case letters.
- 4 It is recommended that the letter height be derived in the same manner as for standard guidance signs (see Chapter 4). Due to the possibility of obtaining high light intensities from narrow focus elements (6° cones), it is possible that normal legibility distances required for adequate driver response and action may be achievable with smaller letter heights than derived by use of the nomograms in Chapter 4. Road authorities are recommended to require that any such claim by a manufacturer be proven in a representative on-site pilot test before accepting smaller letter sizes. Because the signs are light emitting, it may be practical, with an adequate approach distance to use very large letters to obtain reading distances far in excess of those obtainable under vehicle headlamp illumination of retroreflective letters. Characters as high as 1500 mm are available in European systems.
- 5 The recommended minimum spacing between letters is "1d" or the equivalent one vertical row of matrix elements. The minimum recommended spacing between words shall be the equivalent of two vertical rows of matrix elements. In all the above examples the matrix "element" dimension should be taken as the centre to centre dimension of the elements, normally "1d", NOT the diameter of the element itself.
- 6 The size of individual matrix elements will be "1d" square, based on a 7 x 5 matrix. The size of the illuminated element will be dependent on the technology in use and the manufacturers design. Sizes range from 50 mm or more in diameter for larger bulbs, down to small cones for fibre optics of 5 mm diameter. Recommended spacings of illuminated light points of different colours for more general message requirements such as regulatory or warning sign symbols, or for larger custom made matrices are given in Table 9.1.

TABLE 9.1	RECOMMENDED LIGHT POINT SPACINGS- FIBRE OPTIC SIGNS	TABLE 9.1
Light point Colour	Spacing (mm)	
White	30 - 35	
Red	15 - 20	
Yellow	20 - 25	
Green	20 - 25	

7th July 2017

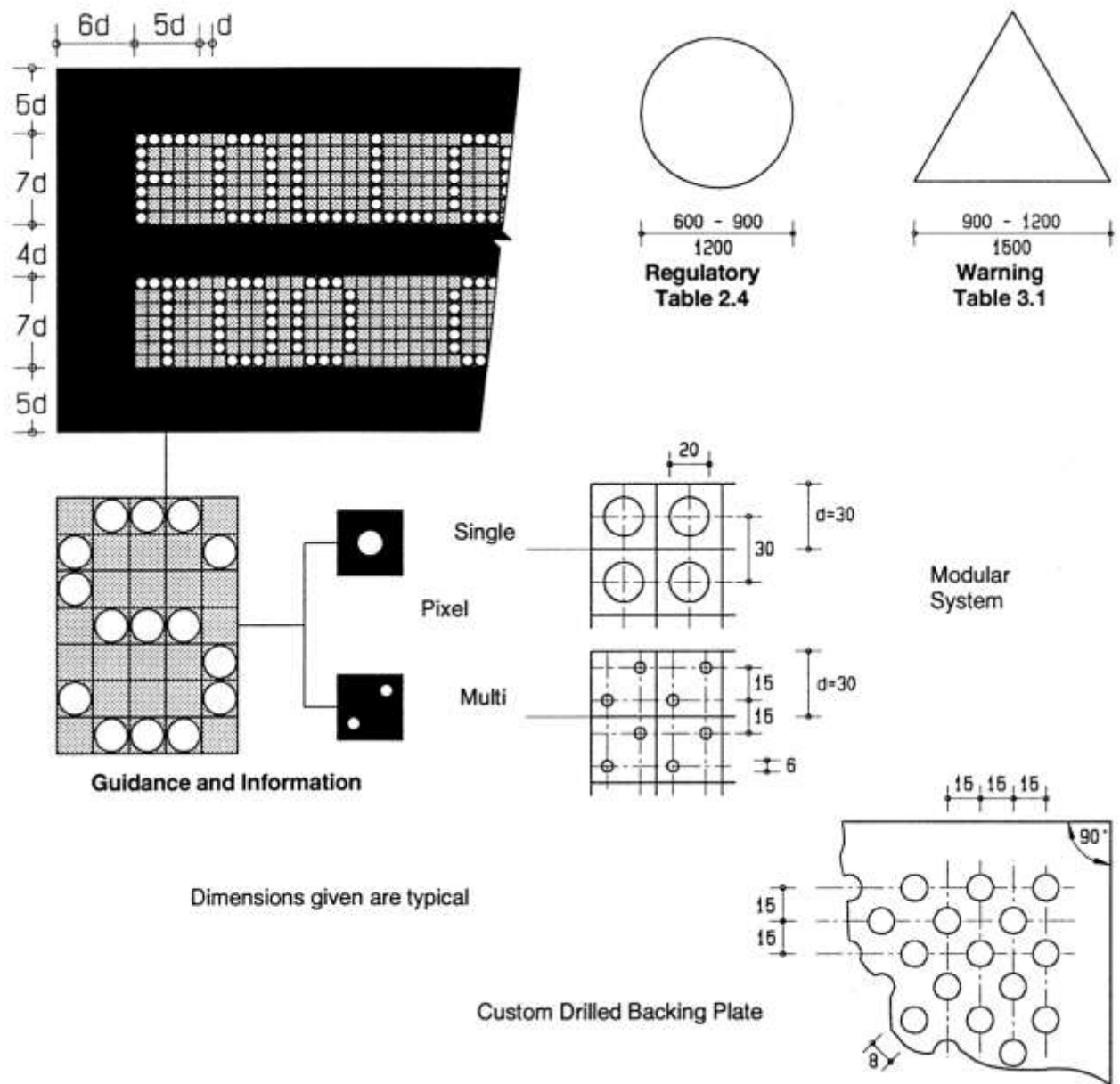

Dimensions given are typical

Custom Drilled Backing Plate

Fig. 9.11

Guidelines for Dimensions of VMS



SOUTHERN
AFRICAN
DEVELOPMENT
COMMUNITY

GLOSSARY OF TERMS

SECTIONS

- 10.1 Introduction
- 10.2 General Terms
- 10.3 Road Sign Terms
- 10.4 Road Marking Terms
- 10.5 Tourism Signing Terms

MAY 2012



SADC RTSM - VOL1

CHAPTER 10

Reproduced under Government Printers Authorization No. 11542 dated 7th July 2017

CHAPTER 10 : GLOSSARY OF TERMS

10.1 INTRODUCTION

- 1 This Glossary of Terms has been created to give a listing of terms commonly used throughout the Manual.
- 2 Instead of placing all the terms into one single listing, the Glossary has been divided into five parts. Namely General Terms, Road Sign Terms, Traffic Signal Terms, Road Marking Terms and Tourism Signing Terms. Section 10.6 has been included due to the wide range of terms specific to tourism signing and to the relative similarity of some of the terms.
- 3 Some terms may appear in more than one part. If a term is not located in what they feel is the most obvious section, users should check the other sections.
- 4 It should be noted that the meaning attached to many terms represents a *de facto* definition of the term. The Manual does not, however, set out to define terms. In fact, generally, the meanings given refer to the manner in which a term has been used in the Manual, which may not be its universal application. No attempt has therefore been made to achieve even general agreement on the meanings given.
- 5 It should also be noted that there are many documents, including legislation and specifications, in which the same or similar terms are defined. Readers should adhere to the meanings given to such definitions in relation to the legal application of such documents, in preference to any similar terms listed here. Terms listed in this chapter, particularly vehicle type terms, which are also listed in the Legislation have used the same wording as is used in the Legislation to reduce any risk of confusion.
- 6 In the texts, where a specific cross-reference is given to a term which is also listed, the term concerned is indicated in capital letters. Within the texts, terms which are themselves explained are highlighted in **bold**.

Reproduced under Government Printers Authorization No. 11542 dated 7th July 2011

Reproduced under Government Printers Authorization No. 11542 dated 7th July 2011

10.2 GENERAL TERMS

These terms, listed alphabetically are considered to be typical of the terminology used, especially with regard to Geometric Design. Terminology also peculiar to Toll Roads is listed.

85%ILE SPEED:	is the speed below which 85% of traffic using a particular section of roadway travels at, irrespective of the speed limit displayed, hence Operating Speed - also known as "the 85 th percentile".
A	
ABNORMAL VEHICLE:	means any vehicle which is operated under a written exemption granted in terms of Legislation.
ACCESS INTERCHANGE:	is an interchange between a freeway and the adjoining lower order road system.
ADVANCE WARNING AREA:	is the section of road leading to the start of a roadworks area in which all pre-advance signs are located - no traffic control or temporary deviation or detour measures should occur within the Advance Warning Area.
ADVISORY SPEED:	is an item of information which may be displayed with a warning or diagrammatic sign, normally in a supplementary plate, to indicate to road users that there is some road feature, for which it is advisable to reduce their speed to that indicated.
AGRICULTURAL VEHICLE:	means a vehicle designed or adapted solely for agricultural activities and includes a tractor but does not include a goods vehicle .
ALTERNATIVE ROUTE:	is a route which offers an alternative to a route for which payment of toll is mandatory and which is signed as an Alternative Route.
ARRESTOR BED:	is a roadside safety facility, filled with specially graded stone, provided as an escape area for heavy vehicles in the event that they have a runaway on a long steep downhill section of roadway.
ARTERIAL ROAD:	is a road in an urban area, optimised for traffic mobility due to limited access from properties and well-spaced junctions , forming part of the main traffic carrying network.
AT-GRADE:	is a junction of roads at the same level; i.e. where no bridge separates the roadways (see GRADE-SEPARATED).
AT-GRADE ROUTE:	is a route with at-grade junctions (see GRADE SEPARATED ROUTE).
AUTHORISED VEHICLE:	means any motor vehicle identified by means of a registration plate, and authorized symbol or name on the vehicle, or an authorised disc affixed to the windscreen of the vehicle, the identification of which is thereby compatible with that displayed on the appropriate road sign.
AUTOMATIC TOLL: (AUTOTOL)	is a form of toll collection whereby the correct toll charge is tendered to an automatic toll collection device, or a toll charge is recorded and invoiced to the owner of a vehicle as a result of in motion automatic vehicle identification.
B	
BARRICADE:	is a temporary and portable device used to demarcate a restricted area set aside for a special use such as roadworks or traffic surveys.
BARRIER:	is a permanent or temporary device, erected on or adjacent to the roadway at hazardous locations, which is capable of physically preventing vehicles from leaving the travelled way , or from entering an area temporarily closed for roadworks or other special operations.
BARRIER SIGHT DISTANCE:	is that distance which allows sufficient time for the drivers of two vehicles, approaching each other in a head-on situation, to stop if they should be left with no other option for avoiding action - the distance approximates to twice the stopping sight distance .
BUFFER ZONE:	is the minimum size of stabilizing area necessary to ensure the safety of workers at the commencement of a road work area (see STABILIZING AREA and WORK AREA).
BUS:	means a motor vehicle designed or adapted for the conveyance of more than 16 persons (including the driver).
BYPASS:	is a roadway , commonly an arterial or freeway , that permits traffic to avoid part or all of an urban area.

C

CENTRAL BUSINESS DISTRICT (CBD):	is the commercially developed business area of a town or city, also commonly known as the city centre .
CHROMATICITY:	is the colour quality of a visual stimulus and corresponds to the hue and saturation of the colour as perceived by a standard observer under standard conditions of illumination - chromaticity makes no reference to the brightness of a light. see CENTRAL BUSINESS DISTRICT.
CITY CENTRE:	
COEFFICIENT OF RETROREFLECTION:	is the value obtained by dividing the luminous intensity of the light reflected by the surface of a retroreflective material by the illuminance at the surface on a plane perpendicular to the direction of the incident light, and by the illuminated area of the surface - expressed in candelas per lux per square metre ($cd/lx/m^2$).
COLLECTOR-DISTRIBUTOR ROAD:	is a type of roadway with a significant traffic carrying function, commonly leading to an at-grade arterial road or a freeway - a specific form of this type of roadway may occur within a cloverleaf systems interchange between an on- and off-ramp, separated but parallel to the main carriageway.
COLTO:	Committee of Land Transport Officials (RSA) (previously known as CSRA/CUTA).
CONE OF VISION:	is the swept area about the normal to a driver's line of vision within which an object can reasonably be expected to be seen by the driver without eye or head movements.
CONSTRUCTION VEHICLE:	means any vehicle used in connection with road construction and/or road maintenance-.
CONTRA FLOW:	is a traffic flow condition whereby two-way traffic occupies a portion of roadway normally reserved for use by one-way traffic - the condition may be a permanent or a temporary arrangement, or it may operate only during limited times of the day.
CSIR:	is the South African Council for Scientific and Industrial Research.
CYCLE ROUTE:	is a separate path, or a portion of roadway signed and marked for use by cyclists only - the route may be numbered.

D

DAYLIGHT HOURS:	are the hours between the officially stated times of sunrise and sunset.
DECISION SIGHT DISTANCE:	is the distance at which a driver can detect a hazard in an environment of visual noise or clutter, recognise it as a threat, select an appropriate speed and path, and perform the required manoeuvre safely and efficiently - observing, reading and acting upon the message of a road sign can fall into this category of hazard.
DEDICATED LANE:	is a lane from which movement in a single direction is mandatory, commonly a turning movement on an at-grade road or an exit movement on a freeway - the lane does not continue beyond turn or point of exit.
DELINEATOR:	is a retroreflective sign or other device spaced at regular intervals along the side of the roadway to define the outer limits of the roadway (also called a "Delineation Device").
DELIVERY VEHICLE:	means a goods vehicle, motor cycle, motor tricycle or motor quadrucycle in the process of loading or unloading goods.
DIPLOMATIC VEHICLE:	is a type of authorised vehicle (see also AUTHORISED VEHICLE).
DETOUR:	a detour involves the redirection of traffic to other parts of the road network, often over significant distances.
DEVIATION:	a deviation involves the local redirection of traffic onto a roadway normally used only by traffic travelling in the opposite direction (contra-flow operation), or onto a specially constructed parallel temporary roadway.
DUAL-CARRIAGEWAY FREEWAY:	is a dual carriageway roadway on which all junctions are grade-separated and with a continuous median island so constructed as to prevent vehicular traffic from crossing - such a roadway may be legally designated as such by the placing of regulatory sign R401 (also referred to as a Class A1 Freeway).

E

EMERGENCY VEHICLE:	is any type of vehicle which may be used in the event of a disaster, civil disturbance or an accident - such vehicles include police, ambulance, fire and civil defence vehicles.
--------------------	---

ENVIRONMENTAL IMPACT:	in the context of a road environment the oversupply of road traffic signs , or any other form of sign can be considered to have an unacceptable environmental impact.
EXCLUSIVE LANE:	see DEDICATED LANE.
EXPECTANCY:	is the process by which individual road users develop sets of ideas and concepts, which when presented with a sensory stimulus of some sort, conditions the response to the stimulus.
EXIT POINT:	is the point of discontinuity at the beginning of a freeway exit- or off-ramp where the ramp edge line deviates from the freeway edge line.

F

FREE SECTION:	is a section of toll route which can be travelled on without paying toll.
FREEWAY:	See DUAL-CARRIAGEWAY FREEWAY (Class A1) and SINGLE CARRIAGEWAY FREEWAY (Class A2).

G

GOODS VEHICLE:	means a motor vehicle other than a motor cycle, motor tricycle, motor quadrucycle, motor car, minibus or bus designed or adapted for the conveyance of goods on a public road and includes a truck-tractor, mobile crane, adapter dolly, converter dolly and breakdown vehicle.
GORE:	is the area immediately beyond the divergence of two roadways , bounded by the edges of those roadways.
GRADE-SEPARATED:	is a junction of roads where the roadways are vertically separated by a bridge. is
GRADE-SEPARATED ROUTE:	a route on which all junctions are grade-separated interchanges .
GROSS COMBINATION MASS: (CGM)	means the maximum mass of any combination of motor vehicles, including the drawing vehicle, and load as specified by the manufacturer thereof or, in the absence of such specification, as determined by the registering authority.
GROSS VEHICLE MASS: (GVM)	means the maximum mass of a motor vehicle and its load as specified by the manufacturer or, in the absence of such specification, as determined by the registering authority.

H

HEAVY VEHICLE:	is a general term used to describe all vehicles over 3500 kg gross vehicle mass. HIGH
OCCUPANCY VEHICLE:	means a motor vehicle in which the number of occupants equals or exceeds the number indicated on an appropriate road traffic sign.
HORIZONTAL CURVE:	is a left or right hand curve in the roadway.
HUMAN FACTORS:	is used to describe the interaction of drivers with the roadway environment and is realised in the form of driver behaviour.
ILLUMINANCE:	is the luminous flux on an element of a surface divided by the area of the element- the unit of illuminance is the lux which is represented by a luminous flux of one lumen on a surface of one square metre (E).
INTERCHANGE:	is a grade-separated junction with one or more turning roadways or ramps for travel between junction legs (see also ACCESS INTERCHANGE and SYSTEMS INTERCHANGE).
INTERSECTION:	means the area embraced within the prolongation of the lateral boundary lines of two or more public roads , open to vehicular traffic, that join one another at any angle, whether or not one such public road crosses the other (see also JUNCTION).
INTERSECTION POINT:	is the point of intersection of the centre lines of two intersecting public roads or roadways .
ISLAND:	see TRAFFIC ISLAND.

J

JUNCTION:	means that portion of an intersection contained within the prolongation of the lateral limits of the intersecting roadways and such junction shall also include any portion of roadway between such lateral limits and any stop or yield marking (see also INTERSECTION).
-----------	---

K

KERBED ISLAND: is a type of **traffic island** demarcated by raised kerbs which may additionally be surrounded or partially surrounded by a **painted island**.

L

LANE DROP: is a reduction in the number of lanes - can be either a Fast Lane Drop or a Slow Lane Drop.

LINK: is a component of the navigational system into which the road network is subdivided - it is typically a section of route between two **nodes** or destinations.

LOCAL AUTHORITY: is a **city council**, **town council**, **village council** or health committee promulgated in accordance with the Local Government Legislation.

LOOP RAMP: is a **ramp** serving a movement to the right, by requiring vehicles to execute such a movement by turning left - typically a 90° right turn is achieved by making a 270° turn to the left. (This principle may be used at **systems** and **access interchanges** - it is possible to configure the loop ramps of a parclo access interchange so that a right turn onto a freeway is achieved by entering **traffic** after making a left turn from the crossroad, and then a 180° turn to the left).

LUMINANCE: is the luminance flux from an **element** of a surface divided by the product of the projected area of the element perpendicular to the beam and the solid angle containing the beam - measured in candelas per square metre (L).

LUMINANCE FACTOR: is the ratio of the **luminance** of a material to that of a perfect reflecting diffuser identically illuminated (measured at a point on the surface of a non-self-illuminating body, in a given direction, under specific conditions of illumination).

LUMINOUS INTENSITY: is the property of a light source that determines the amount of light radiated in a given direction per second measured in candelas - a source of a given luminous intensity will appear to have less brightness the greater the distance from which it is viewed (cd).

M

MAINLINE PLAZA: is a plaza which straddles all lanes of a **toll route**, and at which toll shall be paid by all drivers in one of a number of different ways - a plaza may consist of mainline and **ramp plazas** (see RAMP PLAZA).

MAIN ROAD: is a general term used to describe the more important of two intersecting roadways (see MINOR ROAD).

MANUAL(SADC- RTSM) : is the 3rd Edition of the Southern African Development Community Road Traffic Signs Manual.

MAP : is a form of navigational aid which it is recommended be used during pre-trip planning and during a journey.

"MAY": is a permissive condition used throughout the text.

MEDIAN ISLAND: is a type of **traffic island** used to separate two directions of traffic flow - commonly continuous on **freeways** and with limited openings on **arterial** roads - a short section of such an island may also be used to provide a pedestrian refuge in the middle of a **roadway**.

MERGING SECTION: is a section of **roadway** along which **traffic** is required to come together from two approach lanes into one exiting lane.

METROPOLITAN: is considered, for signing purposes, to be the area within a 60 km radius of the centre of a metropolitan core city (a metropolitan area can also be described as a conurbation of contiguous interrelated development).

MIDI-BUS: means a **bus** which is designed or adapted solely for the conveyance of not more than 30 persons, excluding the driver.

MINIBUS: means a motor vehicle designed or adapted solely or principally for the conveyance of more than nine, but not more than sixteen persons, including the driver.

MINOR ROAD: is a general term used to describe the less important of two intersecting **roadways**.

MOTOR CAR: means a motor vehicle, other than a motor cycle, motor tricycle or motor quadracycle designed or adapted solely or principally for the conveyance of not more than nine persons, including the driver.

MOVEMENT: is an individual uni-directional path of a particular vehicle or pedestrian through a road **junction** or pedestrian crossing - hence right-turn movement etc.

N

- NAVIGATIONAL AID:** is any device, within the road environment or not, which may be employed by road users to assist them with their pre-trip and in-trip planning of a journey, especially to provide adequate orientation.
- NODE:** is a component of the navigational system into which the road network is subdivided - it is typically a destination at the end of a link or section of route.
- NUMBERED ROUTE:** is a Class "A" or Class "B" route which, due to its importance, has been allocated a unique identifying number to assist road users with the navigation process.

O

- OPERATING SPEED:** is the 85thile speed for a given section of road (see 85thILE SPEED).
- ORIENTATION:** is a property of a destination which, when displayed on a direction sign at a junction, enables drivers to decide in which direction to turn in order to reach their intended destination, even if this is not the destination name displayed - hence orientation point (see NAVIGATIONAL AID and NODE).
- OUTDOOR ADVERTISING:** is any type of sign, billboard, or other device, other than a **road traffic sign**, which is located both within the road environment or not and which is positioned to catch the attention of drivers either directly or indirectly.

P

- PARALLEL ROUTE:** is a lower order route which approximately parallels an important route (such routes are commonly parallel to Primary or main routes and are commonly created when a new Primary or main route is constructed - they also commonly function as **alternative routes to toll routes**).
- PASSING SIGHT DISTANCE:** is the minimum **sight distance** required for a vehicle to safely pass another vehicle. (See SIGHT DISTANCE).
- PAY AND DISPLAY:** is a method which may be used by a **local authority**, in terms of Legislation, to collect fees in respect of the parking of vehicles in a **public road** or section of public road - the method requires that drivers make payment in the prescribed manner and display their receipt in a visible position on or within their vehicles.
- PERI-URBAN:** is that area within, or immediately beyond, a town or city boundary which is largely undeveloped but which may have considerable potential for development, particularly in terms of change of land use and traffic generation.
- POINT OF COMMITMENT: (POC)** is the point on the **roadway** beyond which a driver shall have to pay toll - a POC should always immediately follow a point at which a **turn-off to an alternative route** (TTA) is available (see ALTERNATIVE ROUTE and TURN-OFF TO AN ALTERNATIVE ROUTE).
- POINT OF ENTRY: (POE)** is a point at which a driver enters a **toll route**, either as the continuation of an un-tolled route, or at a **junction** involving a positive change of direction (see POINT OF COMMITMENT).
- POSITIVE GUIDANCE:** is a road safety philosophy that advocates the creation and maintenance of a **public road** environment which will provide road users with the optimum amount of visual information.
- PRE-TRIP PLANNING:** is an essential component of the navigation process in order to reduce the risk of misdirection during a journey.
- PUBLIC ROAD:** means any road, street or thoroughfare or, except as determined by Legislation, any other place (whether a thoroughfare or not) which is commonly used by the public or any section thereof or to which the public or any section thereof has a right of access, and includes the verge, any bridge, ferry or drift or any other work or object forming part of or connected with or belonging to such road, street or thoroughfare.

R

- RAMP:** is a turning **roadway** provided at a **grade-separated junction** - hence on-ramp, off-ramp etc. (see INTERCHANGE and TURNING ROADWAY).
- RAMP PLAZA:** is a plaza located only on the off-ramp and/or on-ramp at an **interchange** and at which toll shall be paid by drivers entering or leaving the section of **toll route** in one of a number of different ways (see MAINLINE PLAZA).
- RAMP TERMINAL:** is the **junction** between an off-ramp and a crossroad at a **freeway interchange**.

REFLECTIVE:	is any surface which returns the light which strikes it in a random or scattered manner (see RETROREFLECTIVE).
REGULATION:	means a regulation made in terms of Legislation.
RETROREFLECTIVE:	is the property of a specially manufactured material by which reflected rays of light are preferentially returned in directions as close as possible opposite to their direction of incidence.
RIGHT-OF-WAY:	is a condition whereby one traffic stream has priority over another traffic stream - the removal or allocation of right-of-way is termed traffic control.
ROAD HIERARCHY:	is an arrangement of different classes of road ranging from " Freeway " at the upper end to "Local" at the lower end.
ROAD RESERVE: ROAD	is the portion of land between defined boundaries, that is reserved for public thoroughfare- and other public facilities.
TRAFFIC SIGN:	means a road traffic sign prescribed in terms of Legislation, and includes road signs, traffic signals and road markings.
ROADWAY:	is that portion of a road, street or thoroughfare improved, constructed or intended for vehicular traffic which is between the edges of the roadway.
ROADWORKS:	is any activity related to road construction or road maintenance which impinges upon the roadway either physically or visually.
RURAL:	is that area outside an urban and/or peri-urban area.
S	
SABS:	is the South African Bureau of Standards.
"SHALL":	is a mandatory condition used throughout the text.
SHARED LANE:	is a lane which enters a junction and which may be used to travel through the junction or to turn out of the junction.
SHORT TERM:	in the context of road signing and specifically temporary signs, a period of less than 24 hours.
"SHOULD":	is an advisory condition used throughout the text.
SHOULDER:	is that portion of road, street or thoroughfare between the edge of the roadway and the kerb line.
SIGHT DISTANCE :	is the length of road ahead visible to a driver - the minimum sight distance should be sufficient to enable a vehicle travelling at or near the design speed to stop before reaching a stationary object in the roadway .
SINGLE CARRIAGEWAY FREEWAY :	is a single carriageway roadway on which all junctions (i.e. accesses) are grade-separated and which does not have a median island and carries two-way traffic - such a roadway may be legally designated as such by the placing of regulatory sign R402 also known as a Class A2 Freeway (see DUAL-CARRIAGEWAY FREEWAY).
SLIPROAD:	see TURNING ROADWAY.
SPEED HUMP:	is a device, built according to a standard profile, which may be used to reduce speeds, normally within a residential or industrial area.
STABILIZING AREA:	is the section of a roadworks site in which traffic flow is allowed to stabilize after negotiating a transition area ; if two or more transition areas are required the appropriate stabilizing areas will contain the advance signs for the following transition area.
STANDARD SPECIFICATION:	is a specification drawn up for general use, adherence to which will ensure an acceptable standard of article is produced - several such standards are available covering traffic control devices - it is recommended that when ordering traffic control devices it be stipulated that they, or their component materials, comply with the requirements of these specifications.
STOPPING SIGHT DISTANCE:	is the sum of two distances- the distance travelled by the vehicle from the instant the driver sights an object necessitating a stop to the instant the brakes are applied plus the distance actually required to stop the vehicle from the instant the brake application begins.
STREET:	see Public Road .

SYSTEMS INTERCHANGE:	is an interchange that provides for the free flow of traffic between two or more freeways on different levels (see also ACCESS INTERCHANGE).
T	
TAXI:	means a motor car , motor tricycle or motor quadrucycle which is designed for the conveyance of up to nine passengers, including the driver, and is operating for hire or reward, and which is fitted with an automatic tariff meter.
TEMPORARY CROSSOVER:	is a temporary traffic control arrangement which is a form of transition area , designed to transfer traffic from its standard lane configuration to a temporary alignment which is completely removed from the carriageway in which traffic has been travelling - a crossover shall be demarcated by delineators and/or barriers .
TEMPORARY TAPER:	is a temporary device, which is a form of transition area , created using traffic cones or delineators to narrow the roadway or reduce the number of lanes available to traffic .
TERMINATION AREA:	is the section of a roadworks site in which traffic is returned to the normal road configuration - it is a form of transition area , although it should not be followed by a stabilizing area .
THROUGH LANE:	is a portion of a roadway on an approach to a junction which continues through such a junction.
THROUGH ROAD:	is a roadway which continues through a junction .
TOLL ROUTE : (TOLL ROAD)	is a route on which it is mandatory for users to pay toll charges in order to use the road.
TOUR BUS:	means a minibus , midi-bus or a bus which is owned by or contracted to a tour operator and which is solely or principally used to convey tourists.
TRAFFIC:	comprises pedestrians, ridden or herded animals, vehicles, motor vehicles, buses and any other conveyances, together with their load, either singly or as a whole, while using the road for the purpose of transportation.
TRAFFIC CALMING:	is a traffic control technique intended to reduce the adverse effects of traffic in a local environment.
TRAFFIC CIRCLE:	means a junction which contains a traffic or painted island around which a road user shall travel in a clockwise direction, (or anti-clockwise in Angola).
TRAFFIC CONTROL DEVICE :	is any road traffic sign or other device, including delineation devices, used to regulate, warn, guide or inform road users.
TRAFFIC ISLAND:	is a channelising device which may be kerbed or unkerbed and/or marked on the road surface used as a separation between separate streams of traffic - such devices may be used over considerable distances- e.g. a median island , or they may be located to separate conflicting movements at a junction - e.g. between through movements and a turning roadway .
TRANSITION AREA:	is the section of the roadworks site in which traffic is required to take some action required by temporary traffic control measures.
TRAVELLED WAY:	is the portion of a roadway intended for the normal passage of vehicles.
TURNING ROADWAY:	is a connecting roadway to accommodate turning traffic at a junction - preferably separated from the main area of the junction by a traffic island .
TURN-OFF TO ALTERNATIVE ROUTE (TIA):	are specially chosen points from which drivers not wishing to use a toll route , may conveniently reach an alternative route .
U	
URBAN:	is the portion of a local authority area that is sub-divided into erven, or is surrounded by such erven.
V	
VERTICAL CURVE:	is a sag or crest curve in the road surface linking down- and up-gradients and up-and-down-gradients respectively (see HORIZONTAL CURVE).
VERGE:	means that portion of a road, street or thoroughfare which is not a roadway .
VISUAL ACUITY:	is a measure of the human ability to resolve fine detail on the surface of a viewed object. is
VISIBILITY DISTANCE:	the distance at which an object (a road sign) becomes visible to an observer.

W

- WEAVING SECTION:** is a section of auxiliary **roadway**, commonly found between on-ramps and off-ramps, where drivers entering and leaving the through roadway are required to change direction across each other's path.
- WOONERF:** is a term used to describe an area, normally of residential development, within which the adverse effects of **traffic** have been minimised on a local area basis, either as a result of the original layout of the area or by subsequent additional measures (see TRAFFIC CALMING).
- WORK AREA:** is the section of the **roadworks** site set aside for the actual work - it must be adequately demarcated and protected by temporary **road traffic signs, delineators, barriers** and/or **barricades**.

Reproduced under Government Printers Authorization No. 11542 dated 7th July 2011

Reproduced under Government Printers Authorization No. 11542 dated 7th July 2017

10.3 ROAD SIGN TERMS

These terms, listed alphabetically are considered to be typical of the terminology associated with Road Signs, including materials of manufacture.

B

"BITS": is a measure of the amount of information displayed on a road sign, typically a **guidance** or **information sign** - all **signface** components such as text, arrows, **symbols**, route numbers etc. have been allocated "bit" values - the maximum recommended number of "bits" of information on a signface is 10 "bits". Typical values of signface components in terms of "bits" are-

- (i) words up to/including 8 letters = 1 bit
- (ii) words more than 8 letters = 2 bits
- (iii) arrow (stack-type) = 0,25 bit
- (iv) route number = 0,5 bit
- (v) symbol = 0,5 bit
- (vi) distance information = 0,5 bit
- (vii) interchange number = 0,5 bit

"B MOD": is a letter style with the same size and spacing characteristics as DIN 1451 Part 2 Style "B" lettering but with an increased letter stroke width - this lettering is intended for use as dark letters on a light background to combat possible **overglow** and is only available in uppercase letters.

C

CARDINAL DIRECTIONS: are the points of the compass - North, South, East and West.

CENTRED TEXT: are rows of **symbols** and/or text which are arranged so that the centre of each row is lined up vertically (see JUSTIFICATION).

CLUSTER OF ARROWS: is used on overhead **direction** signs, in an **upward pointing** form, to indicate the lane configuration at a road **junction**, specifically showing exit lanes, shared exit and through lanes, and through lanes (see UPWARD POINTING ARROWS).

CLUSTER OF SIGNS is a group of two or three **tourism** signs mounted on common supports - it is a design requirement of tourism signs that a separate sign be used for each direction for which a tourist facility exists, subject to warrant requirements.

COLOUR CODE: is a prescribed system of colours, or combinations of colours, used in conjunction with sign shapes to simplify early recognition of road sign classes.

COMMAND SIGN: is a sub-class of **mandatory regulatory sign**, the function of which is to indicate that the limit or action displayed shall be complied with by all road users or by the drivers of specific classes of vehicle, as displayed.

COMPOSITE SIGN: is a sign which includes components from different sign classes or sub-class e.g. **direction** and **trailblazer** sign (see INSERT PANEL).

COMPREHENSIVE SIGN: is a sub-class of conditional **regulatory sign**, the function of which is to indicate to road users that the use of a **roadway** or portion of roadway, or some other traffic facility is subject to compliance with a number of road traffic regulations.

CONDITIONAL SIGN: is a type of **regulatory sign** the applicability of which is conditional upon a driver choosing to come under the jurisdiction of the sign.

CONFIRMATION SIGN: is a type of **guidance sign** which may be used to reassure road users that they are travelling in their intended direction - such signs may include distance information but shall not include any form of arrow.

CONSPICUITY: is the attribute of an object or light source to appear prominent in its surroundings.

CONTROL SIGN: is a type of **regulatory sign**, the function of which is to indicate the application of various forms of right of way control - e.g. Stop, Yield etc.

CONTROL DESTINATIONS: are important towns on or within 10 km of routes, or towns or localities that routes have been specifically located to serve, the names of which may appear on direction signs, subject to other policy considerations.

D	
DELINEATOR PLATE:	is a temporary danger plate commonly used in numbers at regular spacings to guide road users in following a temporary alignment of the travelled way .
DE-RESTRICTION SIGN:	is a type of regulatory sign , the function of which is to indicate the termination of the applicability of regulations brought into force by an earlier regulatory sign.
DIAGRAMMATIC SIGN:	is a high visibility type of guidance sign , utilising bold arrow, block and symbol diagrams, which may be used to indicate to road users an often difficult to anticipate change in the layout of the roadway ahead - this sign type is commonly used in temporary form at roadworks .
DIN 1451:	is the German standard style of lettering adopted for use on all road signs - two letter styles, Styles DIN A (compressed) and DIN Bare available (see B MOD).
DIRECTION SIGN :	is a type of guidance sign used to indicate to road users the direction to be taken in order that they may reach their intended destination -direction signs are appropriate at all levels in the road network but are particularly so on Class "A" routes or freeways (highest level) and class "B" routes (secondary level).
DISPLAY ANGLE:	is a small angular deflection, away from the normal horizontal or vertical sign axis, which should be applied to large retroreflective guidance signs to limit the effects of specular glare or reflection .
DISTRACTION FACTOR:	is a factor used to increase derived sign reading times to compensate for different degrees of driver distraction.
DOWNWARD POINTING ARROWS:	are used on overhead direction signs , on an arrow per lane basis so that one arrow is located over each lane, to indicate the destinations which may be reached by the use of any specific lane - these arrows are likely to be gradually replaced by UPWARD POINTING ARROWS (see also CLUSTER OF ARROWS).
F	
FAMILIAR DESTINATIONS:	are destinations selected in terms of their familiarity, even to strangers, and their importance as traffic generators or as a means of defining the route, particularly the terminal points, the names of which are likely to appear on direction signs , subject to other policy considerations.
FIBRE OPTICS:	is a light technology utilising cables comprising glass fibres capable of transmitting light with very limited losses- the technology can be used in the manufacture of light emitting VMS .
FIBRE OPTIC CONES:	are focusing devices used with fibre optic cables to concentrate the light output into a defined angle- cones ranging from 6° to 24° are commonly used, the 6 cone providing the greatest light intensity.
FINGERBOARD SIGN:	is a type of direction sign suitable for use at a tertiary level in the road network - the sign indicates direction by means of its pointed shape.
G	
GUIDANCE SIGN:	is a basic category of road sign that provides navigational guidance to road users to enable them to reach their destinations successfully or to negotiate a changed condition in the roadway ahead - guidance signs may give destination or route direction, confirmation or reassurance, lane direction or indicate the position of a location (commonly a destination).
H	
HAZARD MARKER:	is a type of warning sign used to mark the position of a hazard or potential hazard, normally within the road reserve.
HIGH VISIBILITY BACKGROUND:	is a vertical rectangular backing-board used to increase the target value of a permanent or temporary guidance or warning sign, or combination of regulatory and/or warning signs. Three background sizes are standardised - these are the same as those used for diagrammatic signs .
I	
INDIRECT ROUTE NUMBER:	is a form of direction signface display - the display shows the route number within brackets when the route number concerned is not the number of the immediate route to be entered, but is the number of a route which can be reached after travelling some distance along the immediate route - such a display will only be warranted for an indirect

	route leading to a high level orientation point or important familiar or control destination .
INFORMATION SIGN:	is a basic category of road sign that conveys general information to road users often as a supplement to a regulatory, warning, guidance or other information sign .
INSERT PANEL:	is a panel of information which is displayed on a background of a colour different to that of the main sign on which it is superimposed or inserted – commonly used to indicate locational, trailer, tourism and freeway direction information on a direction sign .
INTERCHANGE (EXIT) NUMBER:	is a form of direction signface display - the display indicates the kilometre distance of the interchange (or junction), and therefore its exit, from a fixed geographical point, commonly the start point of the route, thereby identifying its unique location in the road network.
J	
JUSTIFICATION:	is a guidance signface display technique whereby lines of information comprising symbols and/or text are lined up vertically on one end of the line or the other, hence Left Justification and Right Justification (see CENTRED TEXT).
L	
LAMELLA:	are matrix elements or discs faced with retroreflective material used in certain light reflecting VMS - the discs are capable of rotating to indicate one of two (or more) faces each of which has a different colour (one colour is commonly black), so that different signface messages may be created.
LEFT DESTINATION:	a signed destination reached by turning left at an intersection .
LEGIBILITY:	is the attribute of a road sign which enables viewers to read its message in the form of a symbol, or text, or a combination of both- good legibility requires an adequate contrast between the sign message and sign background, both by day and by night, and sufficient spatial separation between message elements.
LEGIBILITY DISTANCE:	is the distance between the point where the message on a sign first becomes legible, and the sign.
LIGHT EMITTING VMS:	is a type of variable message sign which contains one or more internal light sources by means of which a range of messages can be illuminated for the regulation, warning, guidance or information of road users (see VARIABLE MESSAGE SIGN).
LIGHT REFLECTING VMS:	is a type of variable message sign which relies on conventional retroreflective materials to ensure night-time legibility of various road sign messages by the retroreflection of the light from vehicle headlights (see VARIABLE MESSAGE SIGN).
LOCATION SIGN:	is a type of guidance sign used to identify places or locations which either provide reassurance during the course of a journey, or identify destinations such as towns, suburbs or streets near the end of a journey.
M	
MANDATORY SIGN:	is a type of regulatory sign the applicability of which is such that road users shall, or shall not, take some action as indicated by the sign.
MAP TYPE SIGN:	is a form of direction sign , commonly used on freeways , which displays an arrow with a map-like layout of the junction or exit ahead and gives destination information for each direction of exit from such junction.
MATRIX:	is a type of signface made up of very small switchable elements by which a range of signface layouts may be created, hence variable message sign - a whole matrix may comprise a number of standard modules, each of which is made up of a large number of switchable elements.
O	
ORIENTATION POINT:	is a destination which is deemed to be sufficiently well known to road users that when it is used on direction signs at a junction it enables them to choose the direction they require to take to reach their intended destination, even if this is not the destination name appearing on the sign- orientation points are classified as Familiar, Control or Service Destinations .
OVERGLOW:	is a condition which may result from the superimposition of layers of different colours of retroreflective materials (or non-retroreflective and retroreflective materials), to make up a signface message - the condition may occur when a very high level of contrast in the luminous intensity of adjacent layers exists and is indicated particularly by finely detailed elements of dark coloured symbols or text being overpowered by the light reflected from a light coloured background when illuminated - the risk of overglow may

be minimised by careful symbol design and by careful choice of superimposed materials (see B MOD).

P

PERMANENT SIGN: is a road sign which can be considered as applying to a "steady state" or normal road environment - such signs may display messages which are only applicable for some part of a day or week but which none-the-less represent the normal sign condition (see TEMPORARY SIGN and SELECTIVE RESTRICTION SIGN).

PIXEL: is a matrix element used in **light emitting variable message signs** - the element commonly comprises one or two light points.

PRIMARY MESSAGE: is the upper component of a **selective restriction sign** and comprises a standard **regulatory sign** (see SELECTIVE RESTRICTION SIGN and SECONDARY MESSAGE).

PRIMARY NAME: is that name, which, in combination with an appropriate symbol, is adequate to identify a tourist facility - the function of such a display is to reduce signface message length and thereby sign size - e.g. "Symbol" instead of "Nature Reserve".

are commas, full stops and other marks commonly used in written text.

PUNCTUATION MARKS:

R

READING TIME: is the time in seconds required to read a sign before it disappears from the driver's acceptable **cone of vision** - this time may be assessed from details of the signface display, however it must be compared with the reading time available in terms of the physical characteristics of the **roadway**, the sign position and the approach speed of traffic.

REGULATORY SIGN: is a basic category of road sign that conveys a definite instruction to road users controlling or restricting their conduct.

RESERVATION SIGN: is a sub-category of **conditional regulatory sign** the function of which is to indicate to road users that a roadway, a portion of roadway or other road traffic facility is reserved in terms of some limit, action or object or combination of these, should road users choose to use such facility - reservation signs include parking reservation signs.

RESTRICTION SIGN: is a type of **regulatory sign**, the function of which is to indicate a wide range of restrictions on road users - such restrictions are broadly classified as limits (e.g. a speed or mass limit), actions (e.g. a turning movement or overtaking) or objects (e.g. classes of road user or vehicle).

RETROREFLECTIVE MATERIAL: is a specially manufactured material, the internal construction of which is designed to ensure that reflected rays of light are preferentially returned in directions as close as possible to the opposite directions of the incident rays of light, and that **retroreflection** occurs over a wide range of angles of incident light rays.

RIGHT DESTINATION: is a destination indicated on a **direction sign** which may be reached by turning right at a **junction**.

ROAD TRAFFIC SIGN: a roadside or overhead device mounted in a permanent or temporary position, the shape and colour code of which complies with the provisions for such signs in the SADC - RTSM.

ROLLER BLIND: is a technique whereby a range of **light reflecting variable message signs** may be created - a selection of signfaces are attached to a flexible material which is capable of being rolled between two spindles, either manually or automatically, to achieve a variation in sign message.

ROTATING PLANK: is a form of **light reflecting variable message sign** which comprises a number of vertical or horizontal planks which may be rotated, either manually or automatically, to display one of two signface messages.

ROTATING PRISM: is a form of **light reflecting variable message sign** which comprises a number of vertical or horizontal planks which may be rotated, either manually or automatically, to display one of three or possibly four signface messages.

ROUTE MARKER SIGN: is a type of **guidance sign** used to identify numbered routes and to give advance and directional guidance to road users intersecting such routes - such signs represent the **minimum level** of guidance which should be provided in respect of numbered routes.

S

SECONDARY MESSAGE: is the lower component of a **selective restriction sign** which qualifies the applicability of the **primary message** component of the sign mounted above it in some way - this

	qualification may be achieved in the form of further limit, action or object restriction (see "Primary Message" and "Selective Restriction Sign").
SELECTIVE RESTRICTION SIGN:	is a regulatory sign which, although displayed as on sign, consists of two parts - each with a different message termed the primary message and the secondary message ; the primary message is displayed in the upper part of the sign and may be, in effect, one of the regulatory signs from any of the sub-categories of regulatory sign (the use of control sign primary messages is not generally recommended); the secondary message is displayed in the lower part of the sign, in a rectangular format, and may be one of the Exclusive Secondary Message signs in the sub-category, the function of which is, by display with the primary message, to qualify the applicability of this primary message so that it is applicable only on a selective basis, and not at all times or not to all classes of vehicle, as is the case with a standard regulatory sign (see PRIMARY MESSAGE and SECONDARY MESSAGE).
SEMIMATI:	is a signface finish with very low reflecting properties which is specified for all black components of a signface and may also be specified for the background colour of certain signs if they are not to be used during night-time or their colour code significance is deemed unimportant at night.
SERVICE DESTINATIONS:	are towns having at least one garage or service station and one hotel, which are not more than 10 km from a route, the names of which may appear on direction signs , subject to other policy considerations.
SIGNFACE:	is that part of a road sign displaying a regulatory, warning, guidance or information message.
SPECULAR REFLECTION:	is a form of reflection in which each reflected light wave makes the same angle with the surface as the incident light wave, resulting in a mirror-like effect - this effect can occur with fully retroreflective signs and may be avoided by careful attention to the display angle (see DISPLAY ANGLE).
STACK TYPE SIGN:	is the most common form of direction sign used at the secondary level in the road network- they are used in advance of, and at, road junctions - such signs may comprise one, two, or three horizontal stacks, one stack for each direction of exit from the junction ahead on advance direction signs - each stack shall display only one arrow to indicate the direction to which it applies and the stacks shall always be arranged in the order straight-on, right, left, from top to bottom of the sign (see MAP TYPE SIGN).
STAND ALONE SIGN:	is a free-standing sign which is complete with its own supports.
STANDARD SIGN:	is a term in the text to describe a prescribed permanent or temporary road sign which is not a variable message sign .
STREET NAME ADJUNCT:	is a supplementary term such as "Road" or "Avenue" which is normally added to a street name to identify it as uniquely as possible from other street names - adjuncts may be abbreviated.
SUBSTRATE:	is the material, which may comprise part of the sign structure, to which the signface message is applied.
SUPPLEMENTARY PLATE:	is a type of information sign which may be mounted below a regulatory, warning, guidance or other information sign to supplement the main message - the message on a supplementary plate is commonly a distance message.
SYMBOL:	is a visually perceptible diagram which may be used as a signface message component as a representation of the total message (regulatory, warning, and diagrammatic signs), or in conjunction with text to reduce the overall extent of text which might otherwise be required (direction, freeway direction, local direction, and tourism direction signs), particularly to avoid multiple language text messages.
T	
TARIFF BOARD:	is an information sign which indicates the range of toll charges applicable to a section of toll route ahead - these signs currently have a variety of signface layouts according to the way in which the organisation operating the section of route levies the toll charges.
TEMPORARY SIGN:	is a road sign which can be considered as referring to an abnormal road environment and which is mounted in a temporary position on a fixed or portable support, and is used to convey a temporary message by means of its shape and exclusive yellow and black colour code to regulate, warn, guide, or inform road users (see PERMANENT SIGN and SELECTIVE RESTRICTION SIGN).
TOURISM SIGN:	is a supplementary type of direction sign with a unique brown background colour which may display tourist attraction and/or tourist service destination information- the sign type is intended to supplement the direction sign system at the lower levels of the road network, commonly towards the end of tourist related journeys.

TRAFFIC CONE:	is a temporary portable delineation device which may be positioned at intervals on the road or footpath for occasional short-term channelization of traffic or pedestrians.
TRAILBLAZER:	is a type of route marker sign used to indicate to road users the direction to be taken to reach a route (normally) of higher order than the one in which it is located -the indication is normally an "Indirect" one and the message may be given on a Stand-Alone Sign or an Insert Panel .
TRANSPORT TERMINAL:	is an intermodal transfer point for people and/or goods (e.g. airport, railway station, harbour, bus or taxi terminus).
U	
UPWARD POINTING ARROWS:	are used on overhead direction signs, on an arrow per lane basis, so that the arrows are grouped in clusters to indicate destinations which may be reached by the use of specific lanes (see CLUSTER OF ARROWS).
V	
VARIABLE MESSAGE SIGN: (VMS)	is a type of road sign which is capable of varying its signface display, normally mechanically, electromechanically or electrically, so that a range of regulatory, warning, guidance and/or information messages is available (see LIGHT EMITTING VMS and LIGHT REFLECTING VMS).
W	
WARNING SIGN:	is a basic category of road sign that conveys a warning to road users that there is a condition in the roadway which is hazardous or potentially hazardous - warning signs may be used in advance of such a point or at the point (see HAZARD MARKER sign).

Reproduced under Government Printers Authorization No. 10002 dated 21 July 2017

Reproduced under Government Printers Authorization No. 11542 dated 7th July 2017

10.4 TRAFFIC SIGNAL TERMS

These terms, listed alphabetically are considered to be typical of the terminology used, especially with regard to Traffic Signals.

A	
ALL RED INTERVAL:	is a part of the cycle when red indications are displayed simultaneously on all conflicting phases.
APPROACH:	is a section of roadway , leading to a junction , for which a signal group has been provided.
ASPECT:	is a single traffic signal light source and lens of one of the prescribed colours that is capable of being internally illuminated e.g. "Red Aspect", being a single light unit with a red lens (see SYMBOLIC ASPECT and INDICATION).
C	
CLEARANCE INTERVAL:	is any interval needed or provided to allow any traffic stream that has its right of way terminated to clear the conflict zone before a conflicting traffic stream gains right of way.
CO-ORDINATION:	is the synchronous operation of adjacent traffic signals to facilitate the progressive movement of traffic through a series of such signals.
CRITICAL SIDE ROAD:	is that approach of a minor road joining a main road which is subject to the greater degree of delay to traffic and which may warrant the installation of a traffic signal.
CYCLE:	is a complete sequence of signal indications for a given timing plan.
CYCLE TIME:	is the time interval in seconds to complete a cycle (or the time between the start of any one stage to the next start of the same stage).
D	
DETECTOR LOOP:	is an inductive loop, embedded in the road surface, which is connected to a detector unit, for sensing the passage and presence of vehicles.
DISC:	is a full circular aspect , as distinct from an arrow, green man, red man, bus or tram aspect.
E	
EXCLUSIVE PHASE:	is a phase which runs by itself and not concurrently with any other phase.
F	
FIXED-TIME CONTROL:	is a method of traffic signal operation in which the sequence and duration of stages and the cycle time are fixed for a given signal timing plan.
FLASHING MODE:	is a form of traffic signal operation reserved for use when the traffic signal is subject to a temporary fault condition but still has power available.
G	
GREEN ARROW ASPECT:	is a green aspect having a mask in the shape of an arrow, as distinct from a green disc aspect.
GREEN MAN, RED MAN ASPECTS:	are aspects used for pedestrian signals, having a mask in the shape of the appropriate symbol of a walking or standing man, being green and red in colour respectively.
I	
INDICATION:	is an illuminated aspect , having a particular significance depending on its colour, symbol (if any), and whether it is steady or flashing, hence "Steady Indication" and "Flashing Indication" e.g. a "Steady Red Disc Indication" is a red aspect that is lit and that conveys the meaning attributed to the display of such a signal.
INTERGREEN:	is that part of the cycle between one green phase ending and the next conflicting green phase beginning, comprising a yellow interval followed by an all red interval.
INTERVAL:	any part of the cycle during which the signal indications do not change.

ISOLATED JUNCTION: is a **junction** where, the operation of signals, if provided, would be affected by other adjacent traffic signals to the extent that the signal timings of the junctions should be co-ordinated.

L

LAGGING PHASE: is a vehicular phase that starts after the early cut-off of a **parallel phase**.

LANE DIRECTION CONTROL SIGNAL: is a traffic signal used to indicate the permitted direction of traffic movement in an individual lane which is subject to reversals in the direction of traffic flow during pre-determined periods of the day.

LTORAS: is a form of traffic signal operation permitting drivers to make a "Left Turn On Red After Stop".

M

MIDBLOCK PEDESTRIAN CROSSING: is a pedestrian crossing normally located within the middle third of a **block** between adjacent road **junctions** which is commonly signalled and subject to **pedestrian-actuated control**.

MOVEMENT: is a traffic flow moving in a single direction, normally straight, left or right.

N

NON-REVERT: is a feature of **vehicle-actuated control** whereby right of way will remain with the last expired phase until a call is registered on another phase.

O

OFFSET: is the difference in time between the occurrence of a time reference point at one **traffic signal** and the corresponding reference point at an adjacent traffic signal, in a **co-ordinated** traffic signal system, measured in seconds (in an extensive system the offsets may be measured from a centralised control time reference point).

OVERLAP: is the interval during which non-conflicting (parallel phase) right of way indications run concurrently.

P

PARALLEL PHASES: are two or more non-conflicting phases which run concurrently, generally on parallel approaches or pedestrian crossings.

PEDESTRIAN-ACTUATED CONTROL: is a method of signal operation at signalized **midblock pedestrian crossings** and at certain **junction** traffic signals, whereby a green-man indication for a pedestrian phase will appear only if actuated by the corresponding pedestrian push button.

PEDESTRIAN PHASE: is a **phase** allocated to pedestrian traffic; hence "Exclusive Pedestrian Phase" and "Parallel Pedestrian Phase".

PEDESTRIAN TRAFFIC SIGNAL: is an arrangement of green man and red man aspects for the control of pedestrian traffic. is a

"PELICAN" CROSSING: pedestrian-controlled **traffic signal** crossing.

PHASE: is that part of the **cycle** during which right of way is allocated to a particular vehicular traffic movement or combination of movements, subject to the normal rules of priority, and comprising green and yellow indications.

PRINCIPAL SIGNAL FACE: is one of the two or more **signal faces** provided on an approach, on the near side of the crossing road, (far side in South Africa) in fulfilment of the minimum legal requirements.

R

REVERT: is a feature of **vehicle actuated control** whereby right of way will, in the absence of any pending demands, revert to one or more prescribed traffic movement **stages**, usually for major road traffic, automatically after the expiry of a demand selected **phase**, and will remain there until a demand is registered on another **stage**.

RIGHT-TURN PHASE: is a part of a **cycle** during which right of way is given to right-turning vehicles by means of a flashing green arrow indication whilst opposing traffic is stopped by a steady red disc indication.

ROBOT: is a **traffic signal**.

S

SEMI-VEHICLE-ACTUATED CONTROL:	is a method of vehicle-actuated traffic signal operation in which the display and duration of some, but not all, stages (normally those in which the side-road phases appear) is dependent upon demands or extensions registered by vehicles passing over detector loops (normally located in the side road approaches), or by pedestrian push-button actuation.
SIGNAL:	is a road signal other than a traffic signal , including a yellow warning signal, a flag signal, a hand signal or a flare signal.
SIGNAL FACE:	is a single arrangement of aspects provided for the control of traffic approaching from one direction.
SIGNAL GROUP:	is a number of signal faces , applicable to one signal phase , that display exactly the same indications at the same times.
SIGNAL HEAD:	is an assembly containing one signal face .
SPLIT:	is the division of the cycle length between various stages , normally expressed as a percentage.
STAGE:	is a condition of traffic signal indication in which right of way is given to one or more traffic movements, or phases . A stage starts when all phases that will have right of way in the stage are at green - the stage ends when the first of any of these phases goes to red - stages may therefore be considered to be separated by "Interstage intervals (which include the "Intergreen- intervals), during which phases lose and gain right of way to establish a new stage.
SUPPLEMENTARY SIGNAL FACE:	is any signal face provided over and above the minimum legal requirements to aid conspicuity and/or visibility.
SYMBOLIC ASPECT:	is an aspect having a lens with masking, such as in the shape of an arrow or walking person, as distinct from a circular disc aspect, and intended to apply to a particular class of traffic or to a particular movement.
T	
TRAFFIC SIGNALS:	is a complete signal installation for the control of traffic at a junction or crossing – hence "Vehicular Traffic Signal and "Pedestrian Traffic Signal".
V	
VEHICLE ACTUATED CONTROL:	is a method of signal operation in which the appearance and duration of stages depends on demands and extensions registered by vehicles passing over detector loops, or by pedestrian push-button operation.
VEHICLE EXTENSION (INTERVAL):	is the period or periods of time, pre-set in a vehicle-actuated controller , during which a detected vehicle arrival will extend a current green indication by the duration of such period, subject to the maximum pre-set duration for the current green phase having not expired.

Reproduced under Government Printers Authorization No. 11542 dated 7th July 2017

10.5 ROAD MARKING TERMS

These terms, listed alphabetically are considered to be typical of the terminology used, especially with regard to Road Markings.

B

- BALLOTINI:** are glass beads which are normally added to road marking materials to give them a degree of **retroreflectivity**.
- BIDIRECTIONAL ROADSTUD:** is a roadstud that can reflect light from two opposite approaches.
- BI-FURCATION ARROW:** is a road marking normally comprising two arrows used to indicate an increase in the number of lanes a short distance ahead.
- BROKEN LINE:** is a **longitudinal road marking** comprising short sections of line, spaced at regular intervals so that the lines and gaps are set out in a **modular** manner.

C

- CHANNELISING LINE:** is a continuous **longitudinal road marking** with a no crossing function which may be used to separate streams of traffic moving in the same direction (see NO OVERTAKING LINE and NO CROSSING LINE).
- COLD APPLIED PLASTIC:** is a long life road marking material which may be pre-cut into symbolic and other shapes before application.
- CONTINUITY LINE:** is a **broken longitudinal road marking** used across an access or junction to indicate the limit of the through **roadway**, - also used in advance of a CHANNELISING LINE to differentiate the through roadway from a **dedicated or exclusive turn** or **exit lane**.
- CONTINUOUS LINE:** is an unbroken **longitudinal road marking** (very short breaks to accommodate road - studs do not make such a marking a "broken" line).

D

- DELINEATION DEVICE:** is a low mounted **retroreflective** device, classed as a road marking, used to define the alignment of a **roadway** when attached to such features as guardrails, kerbs or shoulder markers.
- DIVIDING LINE:** is a **broken longitudinal road marking** indicating the division of the **roadway** between streams of traffic travelling in opposite directions.

E

- EDGE LINE:** is a continuous **longitudinal road marking** which indicates the left- or right-hand edge of the travelled way, outside of which lie the shoulders of the roadway.
- "EXTRA" MARKING:** is a high density form of **broken longitudinal road marking** providing a greater number of lines and gaps within a **module** than is provided by a **standard marking**.

G

- GLASS BEADS:** see BALLOTINI.
- GUIDE LINE:** is a **broken longitudinal road marking** which may be used to provide guidance to road users on the alignment of a **roadway**, lane or crossing when these might not otherwise be obvious.

I

- ISLAND MARKING:** is a **traffic island** created either entirely by road markings or by using road markings around all, or part, of a kerbed traffic island - it is commonly referred to as a **painted island** and comprises a continuous boundary line and separate internal solid, bar or chevron markings.

L

- LANE LINE:** is a **broken longitudinal road marking** which permits crossing, separating two streams of traffic travelling in the same direction.
- LINE-TO-GAP RATIO:** is the relationship between the length of road marking and the length of gap between it and the next such marking, used to specify broken longitudinal and transverse markings.
- LONGITUDINAL ROAD MARKING:** is a road marking running approximately parallel to the alignment of the road.

M	
MODULE:	is a repeating sequence comprising one or more line-and-gap patterns which make up a broken longitudinal or transverse road marking .
N	
NO CROSSING LINE: NO	is a double continuous longitudinal road marking used in place of a dividing line to indicate that traffic shall not cross the line for any purpose.
OVERTAKING LINE:	is a continuous longitudinal road marking used in place of, or in addition to, a dividing line to indicate that traffic shall not cross the line to overtake or pass.
O	
OMNIDIRECTIONAL ROADSTUD:	is a roadstud which can reflect light from all directions.
ONE LINE SYSTEM:	is a method of marking a longitudinal dividing line between opposing streams of traffic, which may comprise alternating sections of Dividing Line marking and No Overtaking Line marking in such a way that the Dividing Line marking is replaced by the No Overtaking Line marking.
P	
PAINTED ISLAND:	see ISLAND MARKING.
PREFORMED BONDED TAPE:	is a form of road marking comprising an upper texture surface, normally including ballotini , and an adhesive backing so that it can be quickly applied to the road surface - temporary and permanent adhesives are available - the temporary form of tape may be reused.
R	
REBOUNDABLE CENTRE LINE MARKER:	is a temporary delineation device to demarcate the central area between temporary contra-flow streams of traffic - it should include a base to be temporarily fixed to the road surface, plus a reboundable flap or post which should be in a conspicuous colour such as fluorescent red, red/orange, or yellow - the base and/or flap should also contain a retroreflective or corner cube reflector panel.
"REDUCED" MARKING:	is an economical low density form longitudinal road marking providing fewer lines-and-gaps within a module than is provided by a standard marking .
REVERSIBLE LANE LINE:	is a broken longitudinal road marking used to define lanes in which traffic flow is reversed on a regular basis during the course of a day.
ROAD MARKINGS:	includes permanent or temporary, continuous or broken marks on the road surface provided by lines, arrows, symbols or letters, and roadstuds and other delineation devices for the control, warning, guidance or information of road users.
ROADSTUD:	a permanent or temporary retroreflective device that can be fixed onto or into the road surface to supplement the message of a road marking .
S	
SKID RESISTANCE:	is a factor specifying minimum requirements for the force to be generated by the interaction between a road marking and the tyre(s) of a vehicle under a locked condition (such a factor can also be specified for the road surface).
STACKING LINE:	is a short section of CHANNELISING LINE preceded by a section of "Extra" LANE LINE or CONTINUITY LINE used immediately before a STOP or YIELD LINE on multilane at-grade junction approaches .
"STANDARD" MARKING:	is a medium density form of broken longitudinal road marking providing an average number of lines-and-gaps within a module (see EXTRA and REDUCED MARKINGS).
STOP LINE:	is a continuous transverse (or oblique) road marking immediately behind which vehicles shall stand when stopped by police, traffic signals or a stop sign.
T	
TAPER:	is a straight road marking which changes direction at a regular rate to achieve a narrowing or widening of part of the roadway (it is desirable to specify a length of taper as a full number of module lengths rather than by a rate).
TEMPORARY ROADSTUD:	is a roadstud designed for short term use which can be easily removed from the road surface.

THERMOPLASTIC ROAD MARKING:	is a long life plastic road marking material which is softened by heating for application to the road surface, and which hardens on cooling without appreciable change of properties.
THREE LINE SYSTEM:	is a method of marking a longitudinal dividing line between opposing streams of traffic which retains a Dividing Line marking throughout and which, when overtaking is to be prohibited, comprises an additional No Overtaking Line marking on one or both sides of the Dividing Line marking.
TRANSVERSE MARKING:	is a road marking running at right angles (or approximately so) to the vehicle path.
U	
UNIDIRECTIONAL ROADSTUD:	is a roadstud that can reflect light from one approach only.
Y	
YIELD LINE:	is a broken transverse (or oblique) road marking indicating the point where a vehicle shall yield the right of way to other traffic, to pedestrians or to rail traffic.
Z	
ZIG-ZAG ZONE:	is that section of roadway on the approach to a pedestrian crossing delineated by a ZIG-ZAG ZONE marking.

Reproduced under Government Printers Authorization No. 11542 dated 7th July 2017

Reproduced under Government Printers Authorization No. 11542 dated 7th July 2017

10.6 TOURISM SIGNING TERMS

The following terms are relevant to any discussion on Tourism Signing and tourist destinations. They are included here to assist practitioners in understanding the considerable scope of tourism signing.

A

- ACCOMMODATION:** for the purpose of by-pass town signing accommodation is limited to hotels, motels, inns (symbol GFS C1-1) or chalets (symbol GFS C1-2) or caravan parks (symbol GFS C1-3) (Other categories of accommodation may be catered for in the general context of **tourism signing**).
- ADVERTISING SIGN:** any sign board which is not a **road traffic sign** and which indicates the availability of a service or product for sale by brand name, or which indicates the occurrence of an event, the purpose of which is for gain.
- "AREA" SYMBOL:** a collective **symbol** used to identify a wide range of facilities in an area by a group identification in order to simplify **tourism sign** messages applicable to the area (see symbols GFS A1 and GFS A13).

B

- BEACH (RESORT):** may include any beach related development offering **accommodation** facilities, whether registered as a municipality or not; the symbol may be used if necessary within a town, to indicate the direction to a named or un-named beach.
- BED AND BREAKFAST:** is a form of **accommodation**, commonly in an urban area which is specifically not registered as a hotel, motel etc., offering basic facilities to overnight or holiday tourists; only breakfast should be available.
- BERG (RESORT):** may include any mountain related development offering **accommodation** facilities.
- BOAT LAUNCH:** may include any river or coast based boat launch facility open to the general public.
- BOTANICAL GARDENS:** may include any type of botanical garden, whether specialized or not; if such a garden is named after a town, or province etc. it may be necessary to use the words "botanical gardens" in addition to the **symbol** and/or **primary name**.
- BY-PASS TOWN:** any town which once had a class "A" or "B" route running through it, which route has now been diverted to avoid the developed area of the town (when development spreads to the extent that the by-pass becomes incorporated within the town again, albeit with access control, it is recommended that general tourism signing policies apply).

C

- CLUSTER (OF SIGNS):** a tourism sign cluster is a multi-part tourism sign (maximum three **panels** and/or **stacks**) mounted so that stacks applying to different directions are mounted on common supports with a vertical separation of 100 mm to 200 mm.
- COLOUR CODE:** refers to the background sign colours used for various categories of **guidance sign** (see Chapter4, Section 4.0).
- CURIO SHOP:** may include any facility selling arts and crafts or farm produce located adjacent to a tourist route but not having direct access to such route.

D

- DAM:** is a stretch of water which is available to **tourists** as a picnic or relaxation venue but which does not provide any water based sporting facilities other than public fishing from the shoreline.

E

- ETHNIC ATTRACTION:** is a tourist attraction with a specific relationship to an ethnic, religious, linguistic or other population grouping.

F

- FARM STALL:** see CURIO SHOP.

G

- GAME RESERVE:** may include any natural environment provided for the protection and/or development of fauna, either general or specialized, offering **accommodation** facilities; such reserves

	are generally categorized as resorts and may also specialise in flora and other ecological aspects.
GENERAL TOURIST ATTRACTION:	may include any form of tourist attraction which is not clearly covered by a symbol provided for an existing category of tourist attraction, or which covers such a wide range of categories that the use of no one symbol is appropriate.
GRADED ACCOMMODATION:	refers to any operational system used to indicate the grade or quality of accommodation offered, such as the systems operated from time to time by a grading organisation.
GUEST FARM:	is a form of accommodation offering room and board, normally all meals, located in a farming environment and offering guests specific involvement in the activities of the farm.
GUEST HOUSE:	is a form of accommodation offering room and board, normally at least breakfast and dinner, which is not registered or graded as a hotel; a guest house may be located in urban, peri-urban or rural environments.
GUIDANCE SIGN:	is a basic class of road traffic sign and includes location signs, route marker and trailblazer signs, direction and freeway direction signs, local direction signs, tourism signs and diagrammatic signs used to guide road users from the start to the end of their journeys.
H	
HOLIDAY FARM:	see GUEST FARM.
INLAND WATER RESORT:	may include any stretch of water on which water based sporting activities are permitted and adjacent to which accommodation facilities are available; the symbol may also be used if necessary, within a town to indicate the direction to a water sport facility that is not a resort (see RESORT).
INTERCHANGE NUMBER:	several tourism signs include one or more interchange numbers in black numerals on a white block; these numbers represent a kilometre distance from a major geographical feature or the start of a route, increasing in a northerly or easterly direction; they are commonly used on class "A" routes but may also be used on class "B" routes and they also appear on direction and freeway direction signs .
J	
JUSTIFICATION:	is a term used to describe the vertical lining up of text and/or symbols on the face of a road sign; the rules relating to tourism signs are covered in Volume 1, Chapter 4 and Volume 4, Chapter 7.
LAKE:	see DAM.
M	
MAP:	is a diagrammatic representation of the road network of either a general or specific tourist application; it constitutes a fundamental component of the navigational aids system which may be used outside or inside a vehicle and for pre-trip or on-trip planning; it may also appear as part of the information on a tourist information board or brochures produced by tourism venues; it should always include appropriate route numbers.
MOUNTAIN RESORT :	see BERG RESORT.
MUSEUM:	may include any items of historical, artistic, scientific or cultural interest to tourists, whether exhibited within a building or in an open air environment; if the building housing the facility is a national monument the "National Monument" symbol should be used.
N	
NATURE RESERVE:	may include any natural environment provided for the protection and/or development of flora, either general or specialised, offering accommodation facilities; such reserves are generally categorized as resorts and may also specialise in fauna and other ecological aspects.
NAVIGATIONAL AID:	is any device, including maps, brochures, magazines or newspapers, radio or television, video, Internet, accommodation bookings, information centres - outside the road environment, or guidance signs within the road environment, which enable tourists to successfully reach their intended destinations.
NUMBERED ROUTE:	includes any class "A" or "B" route (Primary, Secondary, Tertiary or Metropolitan).

P	
PARALLEL ROUTES:	applies most commonly to parallel secondary and primary routes, normally resulting from the upgrading of a primary route to a new but parallel alignment and the subsequent reclassification of the old primary route as a secondary or even tertiary route.
PRIMARY NAME:	is that part of the name of a tourist attraction, or accommodation facility one grade above the lowest grade, or a hospital, which is needed to identify it from another similar facility; the primary name should preferably be short and concise and should preferably not be the name of the town in which the facility is located; a primary name is not used at by-passed towns or on service exit sequence signs.
R	
RECREATION:	the refreshment of health and spirit by relaxation and enjoyment.
RESORT:	is a tourist venue where people go for a holiday and/or recreation which for the purpose of tourism signing shall include accommodation facilities; a resort may have a specific theme such as beaches, mountains, water (sports) etc. and it may consist of a facility built specifically as a resort, or facilities at an existing village or town, the principle activities of which are related to holiday and recreational activities.
ROADSIDE STALL:	is a facility within or directly abutting a road reserve from which tourists may purchase arts, crafts and/or farm produce (see also CURIO SHOP/FARM STORE).
REASONABLE ROAD USER/ TOURIST:	is a road user having modest or moderate expectations with regard to guidance signing who is, therefore, prepared to make a contributory effort in the navigational process.
ROOMS:	are a form of accommodation which make no provision for the taking of meals, self-catering or otherwise.
REST AND SERVICE AREA:	is a facility provided to offer the road user a wide range of tourist services, of a high standard, in an environment which encourages the tourist to also take a rest with the general objective of improved road safety.
S	
SCENIC ROUTE:	is a route, which may be short or long, which includes in its length sections of attractive natural scenery; a scenic route may include man-made features or facilities which impart a theme to the route in addition to its natural beauty.
SEASIDE RESORT:	see BEACH RESORT.
SERVICE FACILITY:	is a facility which can render assistance or be of importance to a road user and which has been established principally to service the short term needs of motorists and/or their vehicles to cater for emergency situations (in terms of general applications accommodation facilities are categorised separately although they are included in the general description of "service" when applied to the signing of by-passed towns).
SIGN PANEL:	an internal division of a tourism sign stack - a sign stack may include a maximum of three panels .
SIGN STACK:	a sign which contains tourism information relevant to one direction of travel only; a maximum of three sign stacks may make up a cluster (see CLUSTER and SIGN PANEL).
SPECIAL EVENT:	a tourist attraction or service which is only available for a short time or on a part-time basis.
SUPPLEMENTARY SYMBOLS:	standard tourism sign symbols used at half size below the primary name of a facility, either in addition to a main symbol or in place of a main symbol; the use of symbols GFS C1-1, (Hotel) and GFS 84-1, (Restaurant), as supplementary symbols on tourism signs for hotels is recommended to keep sign areas down (see Level 3 warrants for use of supplementary symbols • Volume 2, Chapter 4 Supplement).
SYMBOLS:	tourism symbols approved by the relevant Road Traffic Signs Technical Committee for use on road traffic signs .
T	
TOURISM:	is deemed to include any activity concerned with the temporary movement of people to destinations outside the areas or places in which they normally live and work, and their activities during their stay at these destinations.
TOURIST:	is considered to be a person travelling to or for pleasure in the broadest sense.

TOURIST FACILITY:	broadly includes almost any attraction or service which may be of interest to reasonable numbers of strangers to an area.
TOURISM SIGNING:	guidance information provided to supplement the information given on the orientational system direction signs , when such information is not appropriate for inclusion on such direction signs, and when road users cannot reasonably perceive the existence or location of tourist attractions or service facilities from the information given on the direction signs.
"TOTEM" SIGNS:	are a special sub-group of tourism signs only used within a rest and service area or other "closed" tourist facility such as a game reserve or nature reserve.
V	
VIEW POINT:	refers to an elevated position along-side a road or a hiking trail which offers tourists a panoramic view of the area in which they are travelling.
W	
WARRANTS:	are written statements in Volume 2, in the Supplement to Chapters 4 and 9, relating to specific types of tourist attraction and service which are applied when assessing a request for a tourism sign to ensure that the character and quality of the facility complies with standards acceptable to reasonable tourists .
WINE CELLAR:	is a specific tourist attraction open to the public and offering wine-tasting and/or tours of the facility; use of the symbol is not appropriate to groups of wine cellars comprising what is commonly called a "wine route".

Reproduced under Government Printers Authorization No. 1/15/2012 dated 7th July 2011



SOUTHERN
AFRICAN
DEVELOPMENT
COMMUNITY

INDEX

SECTIONS

- 11.1 General Index
- 11.2 List of Figures
- 11.3 List of Tables

MAY 2012



SADC RTSM - VOL1

CHAPTER 11

Reproduced under Government Printers Authorization No. 11542 dated 7th July 2017

CHAPTER 11: INDEX

11.1 GENERAL INDEX

Description	Sign Type	Page No.
A		
Abnormal Vehicle Reservation, Reservation Signs	Regulatory Signs	2.5.5-6, 2.5.8
Abnormal Vehicles Only, Command Signs	Regulatory Signs	2.3.9, 2.3.12
Abnormal Vehicles, Prohibition Signs	Regulatory Signs	2.4.16, 2.4.19
Access Interchange, Information Display, Freeway Signs	Guidance Signs	4.9.5
Accident, Symbolic Signs	Warning Signs	3.4.24
Accommodation Facilities, Definition	Guidance Signs	4.10.4
Accommodation Symbols	Guidance Signs	4.0.18-27
Action-Limit Signs, Selective Restriction Signs	Regulatory Signs	2.0.18-19, 2.7.11
Action-Object Signs, Selective Restriction Signs	Regulatory Signs	2.0.18-19, 2.7.12
Action Sub-Group, Exclusive Secondary Messages	Regulatory Signs	2.7.5
Additional Lane, Diagrammatic Signs	Guidance Signs	4.0.33-34, 4.12.14-16
Additional Toll Signs	Guidance Signs	4.14.6
Advance Direction, Map-Type, Direction Signs	Guidance Signs	4.8.16-17
Advance Direction Route Marker	Guidance Signs	4.7.1Q-11
Advance Direction, Stack-Type Composite Direction Signs	Guidance Signs	4.8.12-13
Advance Direction, Stack-Type Direction Signs	Guidance Signs	4.8.6-8
Advance Exit Direction, Freeway	Guidance Signs	4.9.18-19
Advance Exit, Freeway, Tourism Signing	Guidance Signs	4.10.18-20
Advance Local Direction, Stack-Type Signs	Guidance Signs	4.11.12-13
Advance Off-Ramp Terminal Direction, Freeway Signs	Guidance Signs	4.9.24
Advance Trailblazer, Route Marker Signs	Guidance Signs	4.7.3
Advance Transport Trailblazer, Route Marker Signs	Guidance Signs	4.7.5
Advance Turn, Tourism Signs	Regulatory Signs	4.10.21-24
Agricultural Vehicles Only, Command Signs	Regulatory Signs	2.3.9, 2.3.13
Agricultural Vehicles, Prohibition Signs	Warning Signs	2.4.16, 2.4.20
Agricultural Vehicles, Symbolic Signs	Warning Signs	3.4.24
Aircraft, Low Flying, Symbolic Signs	Guidance Signs	3.4.23
Alphabet, Legend	Guidance Signs	4.3.3
Alternative Route Marker	Guidance Signs	4.7.13
Alternative Routes, Toll Routes	Regulatory Signs	4.14.3
Ambulance/Emergency Vehicle Reservation,	Traffic Signals	2.5.5-6, 2.5.9
Analysis, Engineering, Warrants	Guidance Signs	6.8.1
Angled Arrows, Pedestrian Signs	Regulatory Signs	4.13.6
Animal Drawn Vehicles Only, Command Signs	Regulatory Signs	2.3.9, 2.3.13
Animal Drawn Vehicles, Prohibition Signs	Warning Signs	2.4.16, 2.4.20
Animals, Domestic, Symbolic Signs	Warning Signs	3.4.5
Animals, Wild, Symbolic Signs	Traffic Signals	3.4.6
Area of Control, Vehicular Traffic	Traffic Signals	62.1
Arrangement of Aspect on a Signal Face, Vehicular Traffic	Road Markings	6.0.1-9
Arrestor Bed Ahead, Warning	Guidance Signs	7.3.8
Arrestor Bed, Diagrammatic Signs	Road Markings	4.12.23-24
Arrows, Bi-furcation, Guidance	Guidance Signs	7.4.3
Arrows, Downward Pointing	Road Markings	4.2.4, 4.2.6
Arrows, End of Exclusive Use Lane, Warning	Road Markings	7.3.9
Arrows, Information, Guidance	Road Markings	7.4.3
Arrows, Lane Reduction, Warning		7.3.5
Arrows, Mandatory Direction, Ahead, Warning	Road Markings	7.3.7
Arrows, Mandatory Direction, Regulatory	Road Markings	7.2.20
Arrows, Map Type Signs	Guidance Signs	4.2.1, 4.2.3
Arrows, Pedestrian Signs	Guidance Signs	4.13.6