

QLD - c	QLD - d	QLD - e
---------	---------	---------

- 500 kV
- 330 kV
- 275 kV
- 220 kV
- 132 / 110 kV
- 66 kV
- 33 kV
- 22 kV

- Generator
- Wind Farm
- Static Var Compensator
- Synchronous Condenser
- Circuit breaker
- Isolator
- Capacitor Bank
- Reactor
- Series Reactor
- 2 Winding tap transformer
- 3 Winding tap transformer
- Auto transformer
- 2 Winding fixed tap transformer
- 3 Winding fixed tap transformer

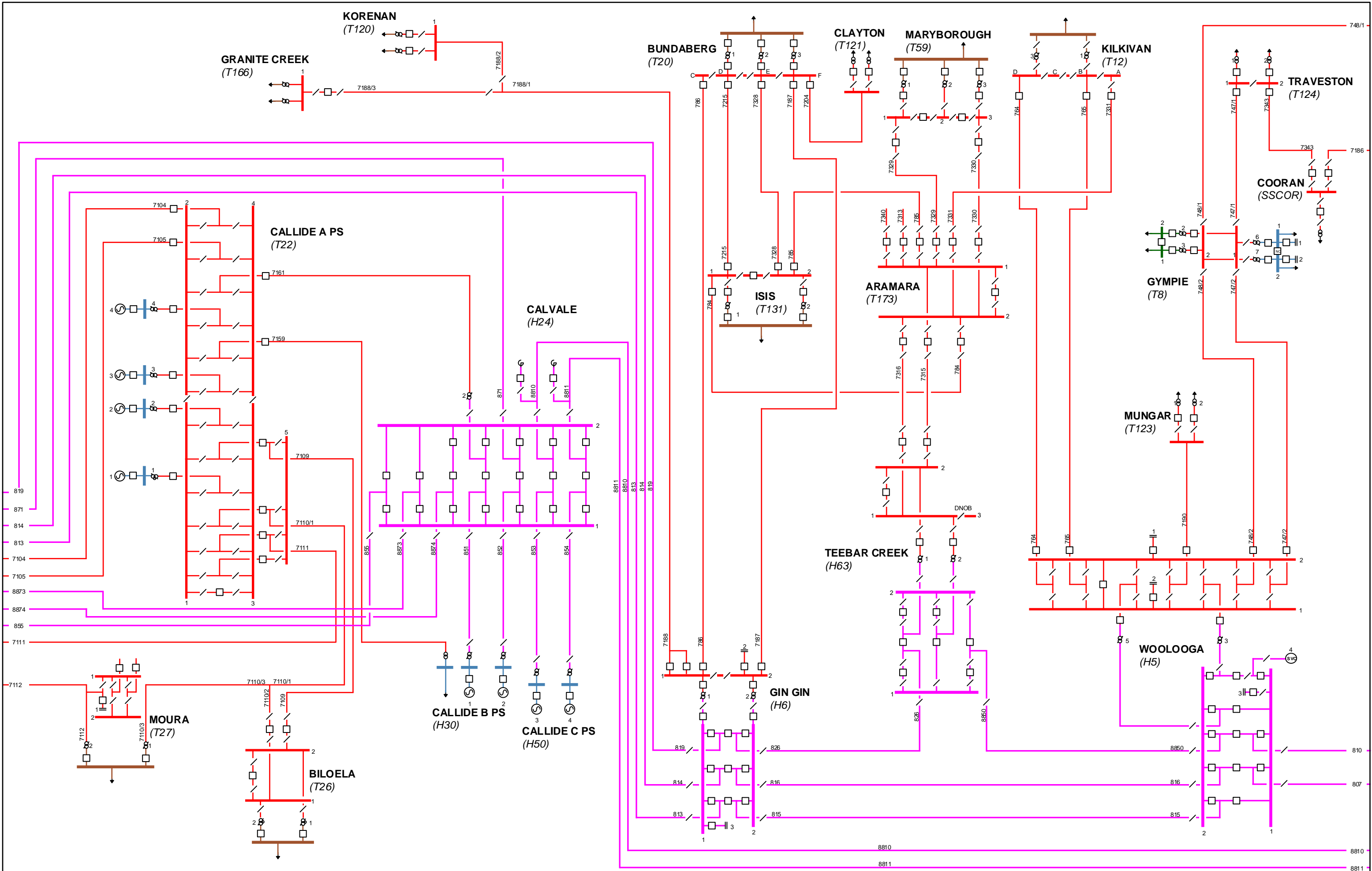



QLD - e	QLD - f	QLD - g
---------	---------	---------

500 kV	Generator	Circuit breaker	Reactor	2 Winding tap transformer	2 Winding fixed tap transformer
330 kV	Wind Farm	Isolator	Series Reactor	3 Winding tap transformer	3 Winding fixed tap transformer
275 kV	Static Var Compensator	Capacitor Bank	Auto transformer		
220 kV	Synchronous Condenser				
132 / 110 kV					
66 kV					
33 kV					
22 kV					

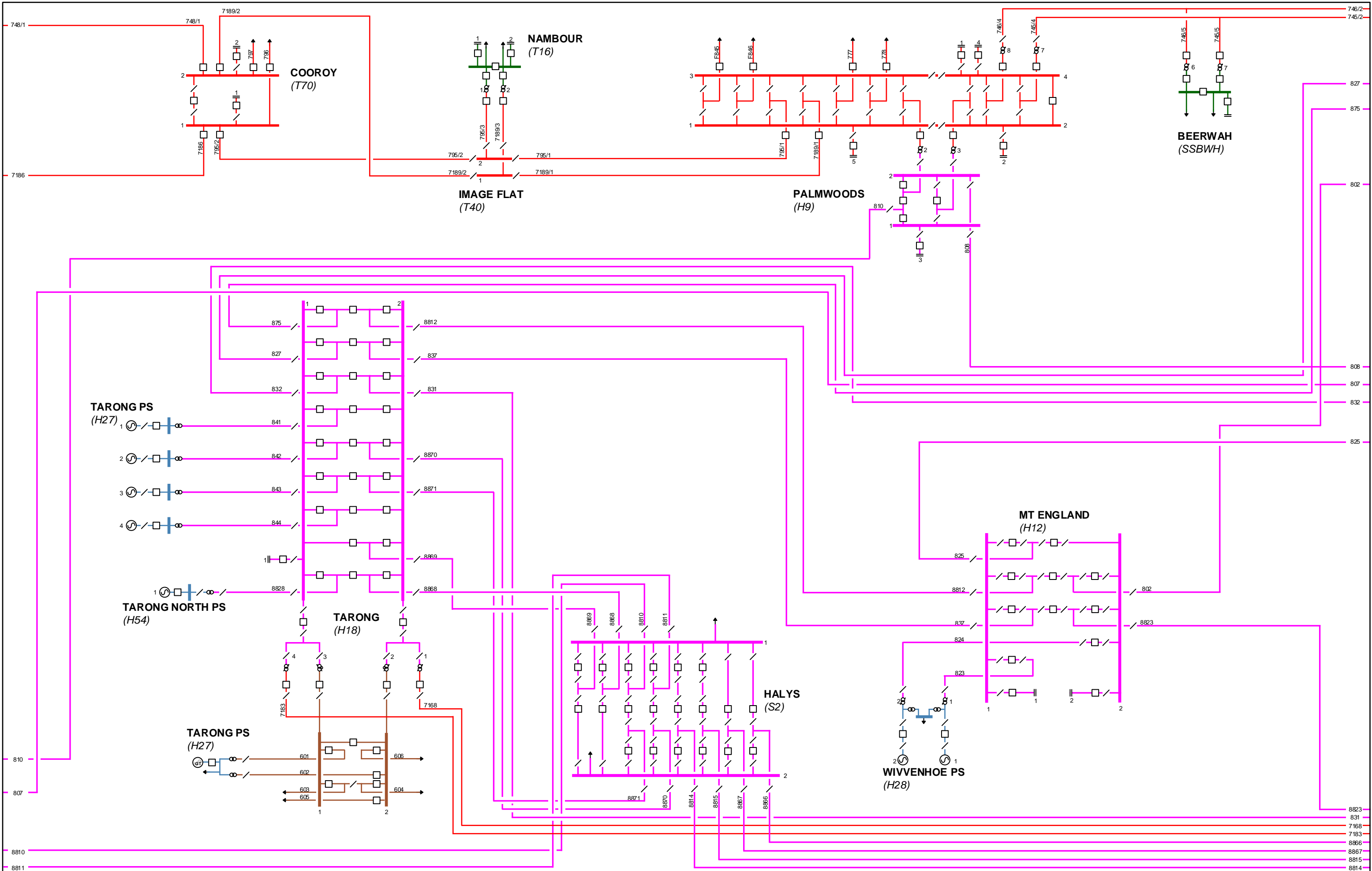

QLD - f	QLD - g	QLD - h
---------	---------	---------

- 500 kV
- 330 kV
- 275 kV
- 220 kV
- 132 / 110 kV
- 66 kV
- 33 kV
- 22 kV

- Generator
- Wind Farm
- Static Var Compensator
- Synchronous Condenser
- Circuit breaker
- Isolator
- Capacitor Bank
- Reactor
- Series Reactor
- 2 Winding tap transformer
- 3 Winding tap transformer
- Auto transformer
- 2 Winding fixed tap transformer
- 3 Winding fixed tap transformer

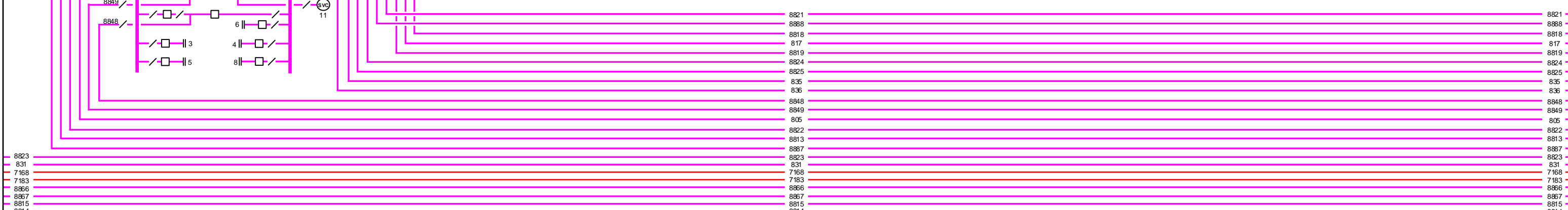
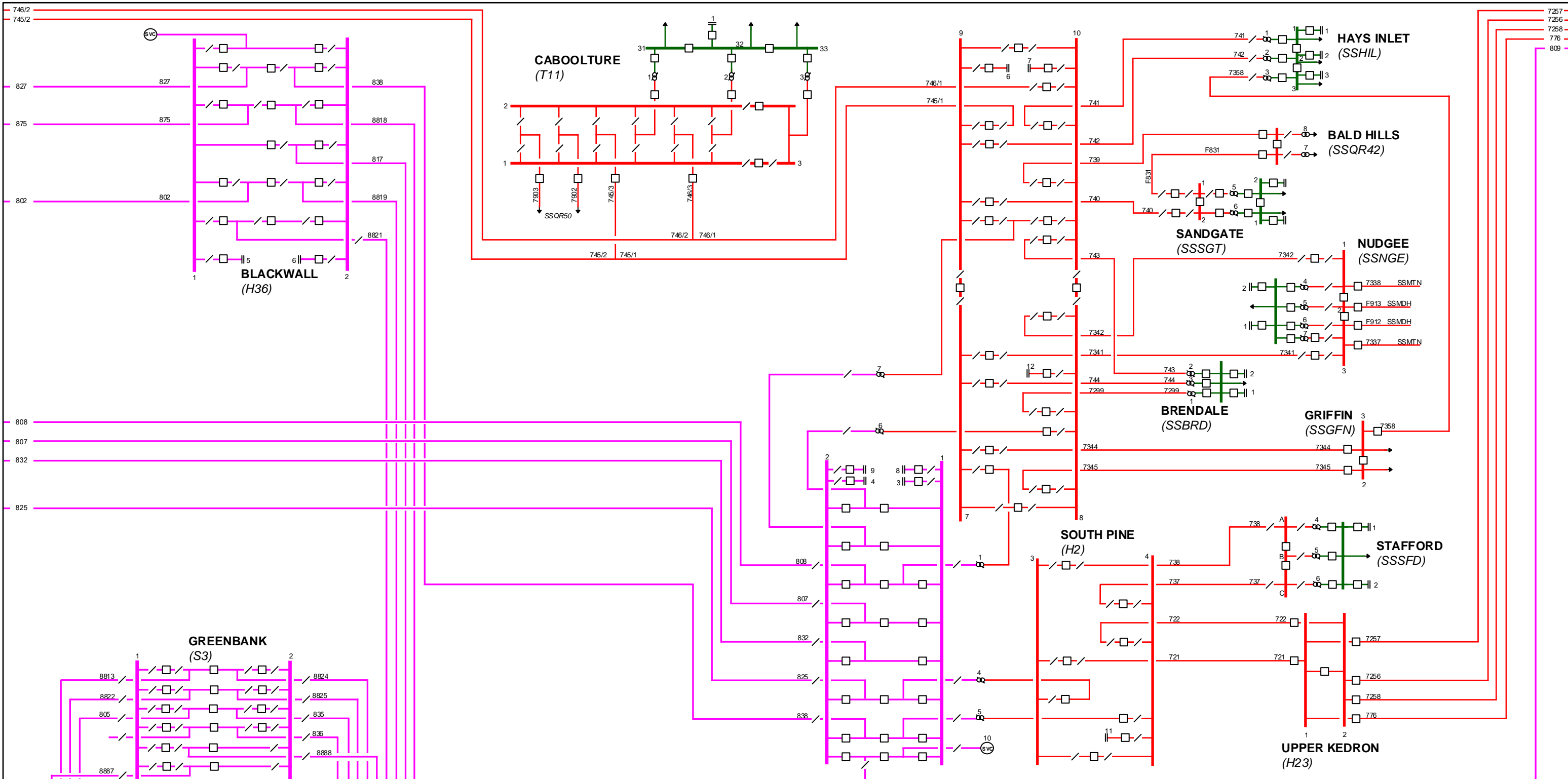

QLD - g	QLD - h	QLD - i
---------	---------	---------

<ul style="list-style-type: none"> <li><span style="color: yellow;">—</span> 500 kV</li> <li><span style="color: orange;">—</span> 330 kV</li> <li><span style="color: magenta;">—</span> 275 kV</li> <li><span style="color: blue;">—</span> 220 kV</li> <li><span style="color: red;">—</span> 132 / 110 kV</li> <li><span style="color: green;">—</span> 66 kV</li> <li><span style="color: cyan;">—</span> 33 kV</li> <li><span style="color: black;">—</span> 22 kV</li> </ul>	<ul style="list-style-type: none"> <li> Generator</li> <li> Wind Farm</li> <li> Static Var Compensator</li> <li> Synchronous Condenser</li> <li> Circuit breaker</li> <li> Isolator</li> <li> Capacitor Bank</li> <li> Reactor</li> <li> Series Reactor</li> <li> 2 Winding tap transformer</li> <li> 3 Winding tap transformer</li> <li> 2 Winding fixed tap transformer</li> <li> 3 Winding fixed tap transformer</li> <li> Auto transformer</li> </ul>	<p>This diagram is intended to be a high-level representation only, interested parties should always consult with their relevant transmission network service provider (or equivalent) for more accurate information.</p> <p>DATE: 14-10-2016</p>
---	---	---



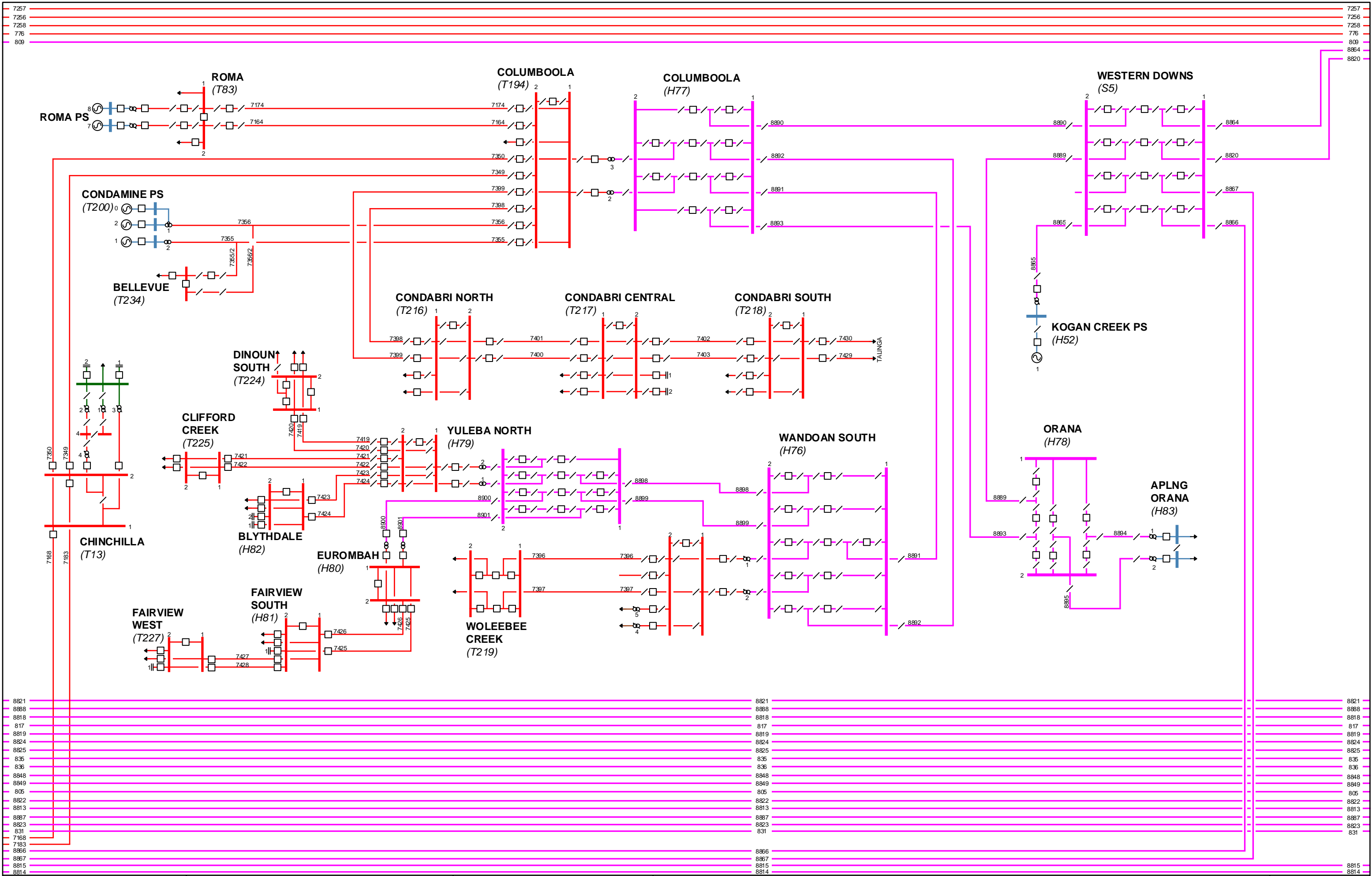

**AUSTRALIAN ENERGY MARKET OPERATOR  
HIGH VOLTAGE NETWORK  
MAIN SYSTEM DIAGRAM  
QUEENSLAND - i**

QLD - h	QLD - i	QLD - j
---------	---------	---------

- 500 kV
- 330 kV
- 275 kV
- 220 kV
- 132 / 110 kV
- 66 kV
- 33 kV
- 22 kV

- |                         |                 |                  |                           |                                 |
|-------------------------|-----------------|------------------|---------------------------|---------------------------------|
| Generator               | Circuit breaker | Reactor          | 2 Winding tap transformer | 2 Winding fixed tap transformer |
| Wind Farm               | Isolator        | Series Reactor   | 3 Winding tap transformer | 3 Winding fixed tap transformer |
| Static Var Compensator  | Capacitor Bank  | Auto transformer |                           |                                 |
| Synchronous Condensator |                 |                  |                           |                                 |

This diagram is intended to be a high-level representation only, interested parties should always consult with their relevant transmission network service provider (or equivalent) for more accurate information.

DATE: 14-10-2016

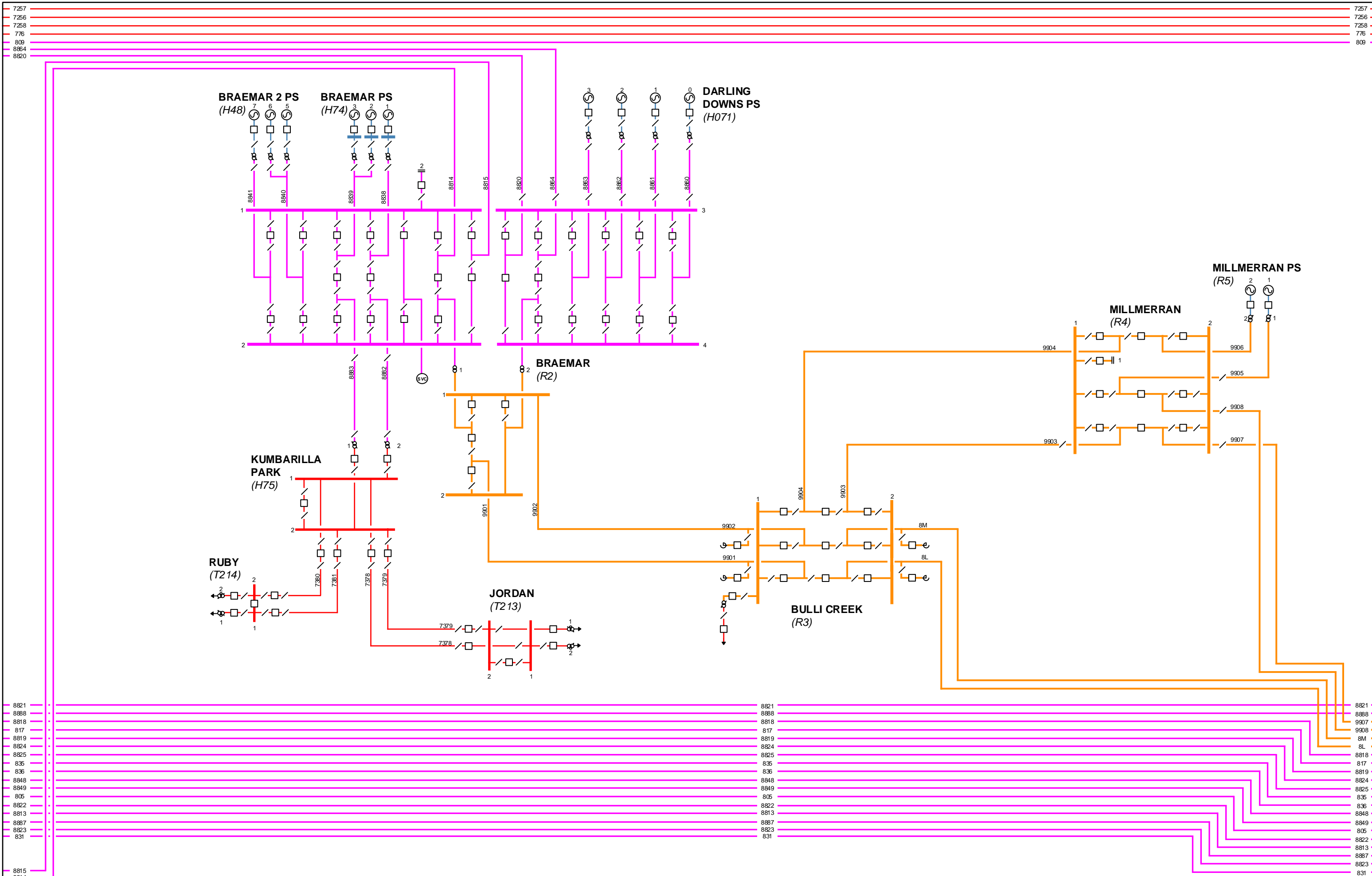

7257  
7256  
7258  
776  
809  
8864  
8820

8821  
8888  
8818  
817  
8819  
8824  
8825  
835  
836  
8848  
8849  
805  
8822  
8813  
8887  
8823  
831

8815  
8814

7257  
7256  
7258  
776  
809

8821  
8888  
9907  
9908  
8M  
8L  
8818  
817  
836  
8848  
8824  
8849  
805  
8822  
8813  
8887  
8823  
831



AUSTRALIAN ENERGY MARKET OPERATOR  
HIGH VOLTAGE NETWORK  
MAIN SYSTEM DIAGRAM  
QUEENSLAND - j

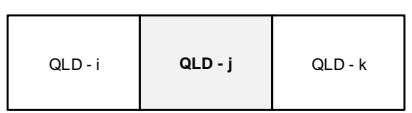

- 500 kV
- 330 kV
- 275 kV
- 220 kV
- 132 / 110 kV
- 66 kV
- 33 kV
- 22 kV

- Generator
- Wind Farm
- Static Var Compensator
- Synchronous Condensator
- Circuit breaker
- Isolator
- Capacitor Bank
- Reactor
- Series Reactor
- 2 Winding tap transformer
- 3 Winding tap transformer
- Auto transformer
- 2 Winding fixed tap transformer
- 3 Winding fixed tap transformer

This diagram is intended to be a high-level representation only, interested parties should always consult with their relevant transmission network service provider (or equivalent) for more accurate information.

DATE: 14-10-2016

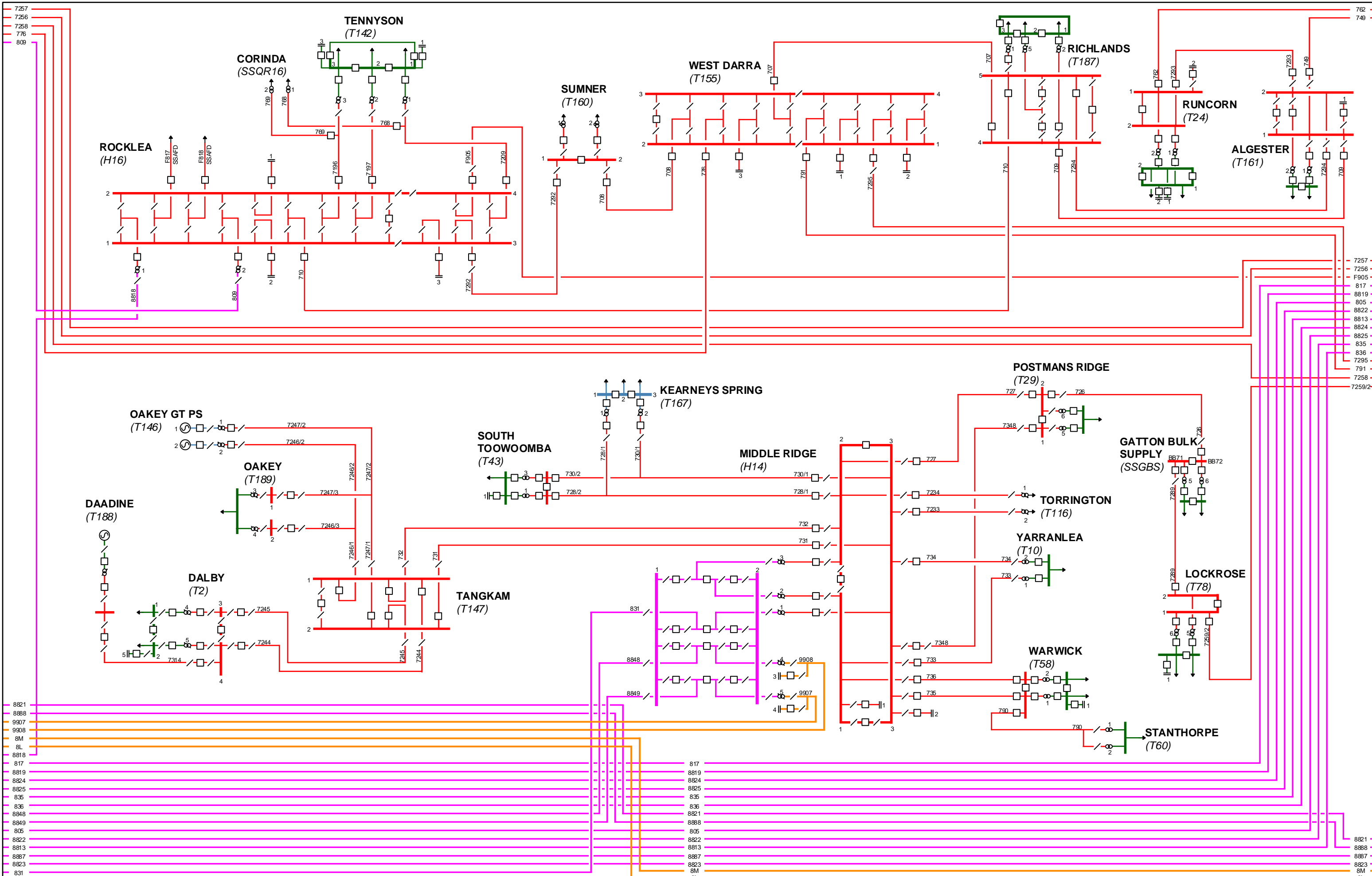

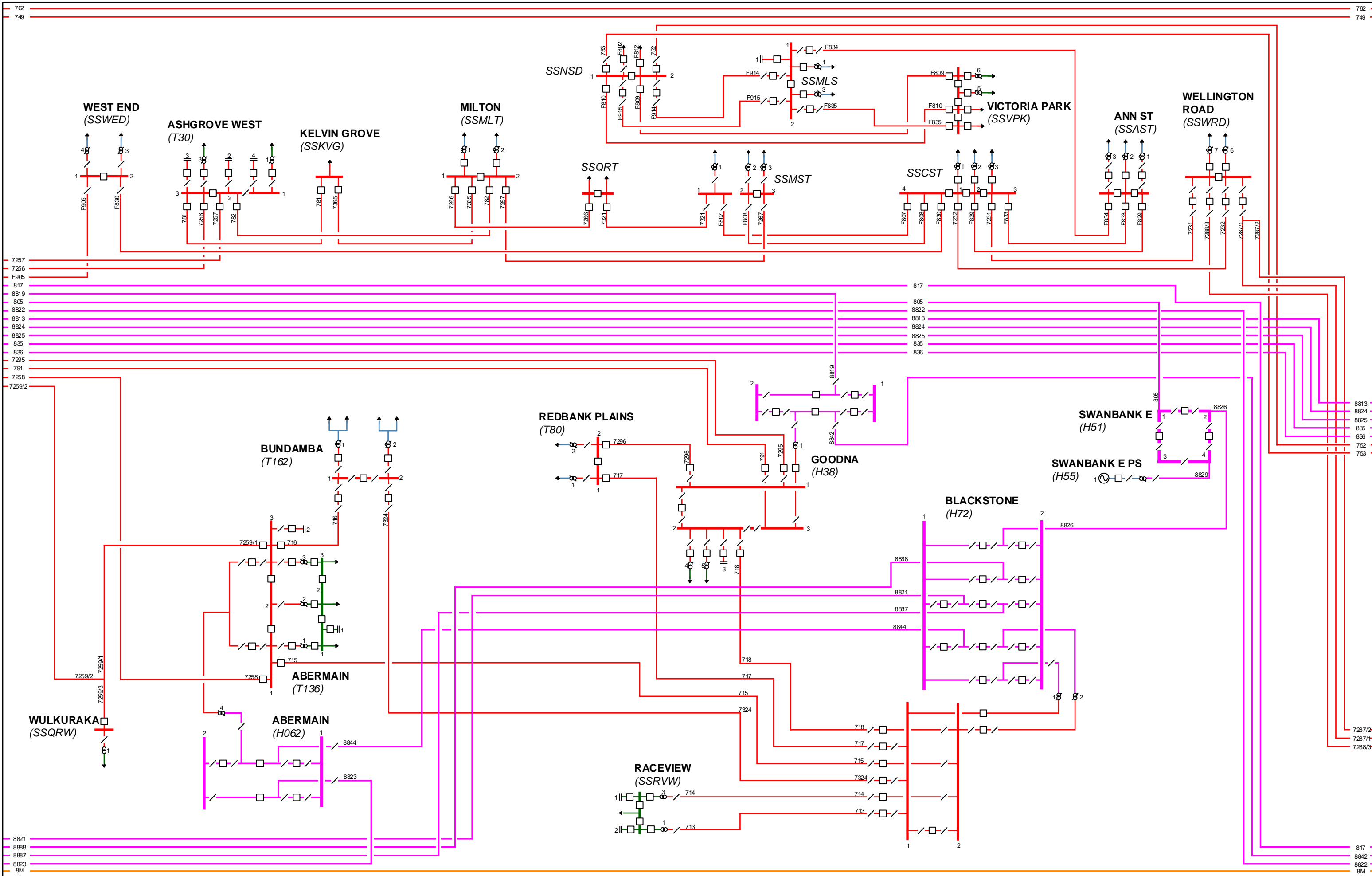

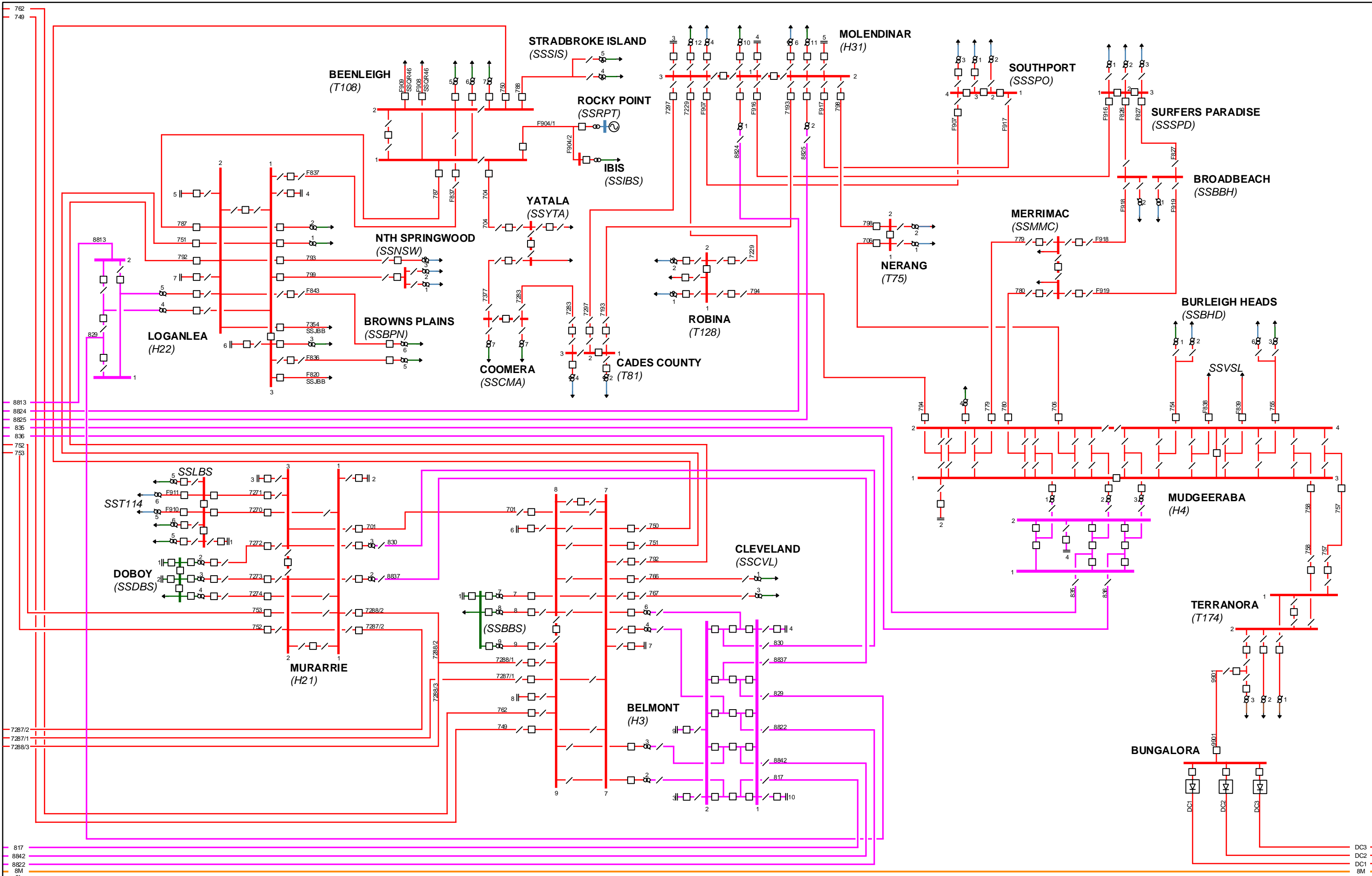

762  
749  
8813  
8824  
8825  
835  
836  
752  
753  
7287/2  
7287/1  
7288/3  
817  
8842  
8822  
8M  
8L

DC3  
DC2  
DC1  
8M  
8L



AUSTRALIAN ENERGY MARKET OPERATOR  
HIGH VOLTAGE NETWORK  
MAIN SYSTEM DIAGRAM  
QUEENSLAND - m

QLD - l	QLD - m	NSW - a
---------	---------	---------

- 500 kV
- 330 kV
- 275 kV
- 220 kV
- 132 / 110 kV
- 66 kV
- 33 kV
- 22 kV

- Generator
- Wind Farm
- Static Var Compensator
- Synchronous Condensor
- Circuit breaker
- Isolator
- Capacitor Bank
- Reactor
- Series Reactor
- 2 Winding tap transformer
- 3 Winding tap transformer
- Auto transformer
- 2 Winding fixed tap transformer
- 3 Winding fixed tap transformer

This diagram is intended to be a high-level representation only, interested parties should always consult with their relevant transmission network service provider (or equivalent) for more accurate information.

DATE: 14-10-2016

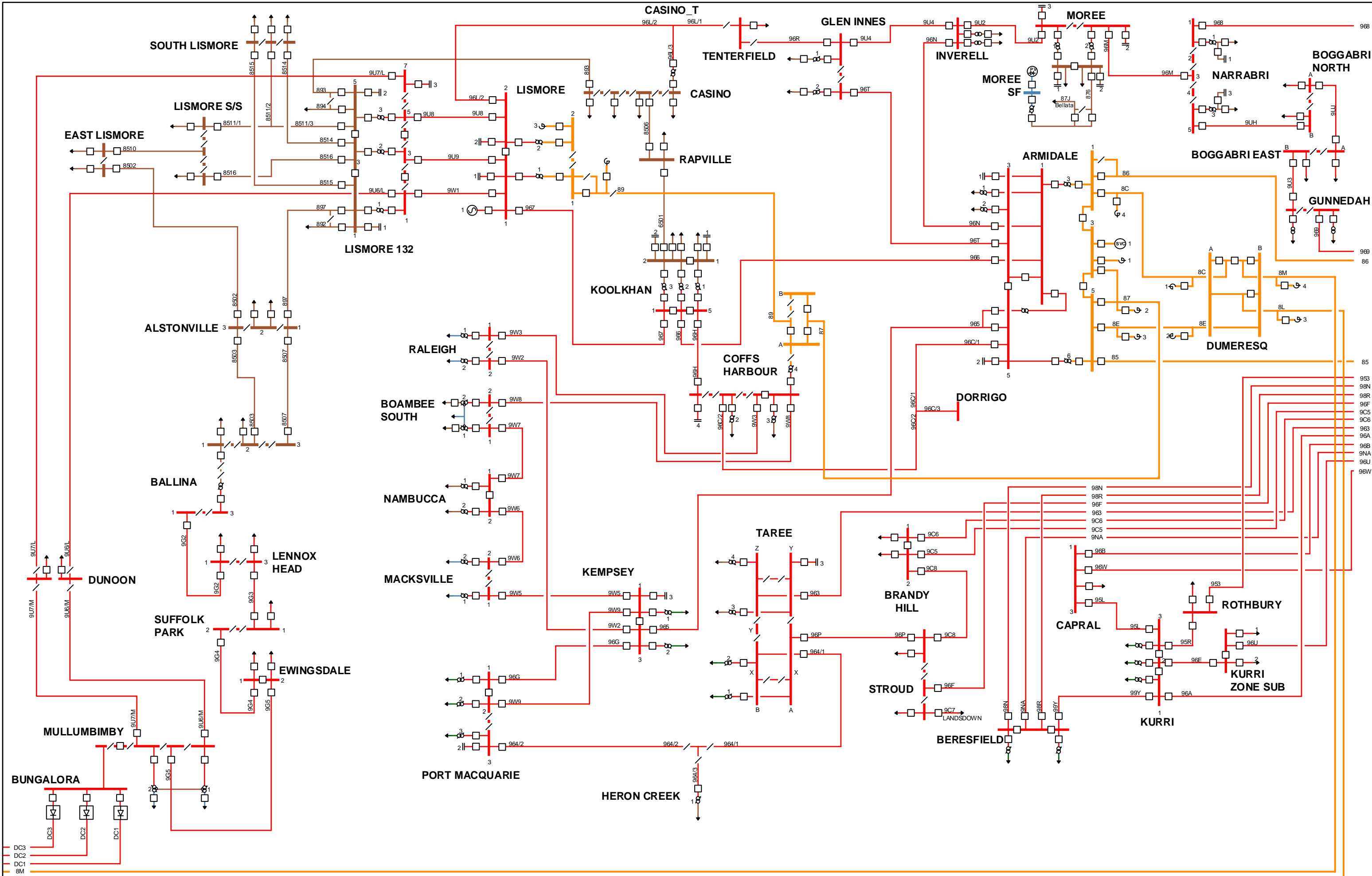

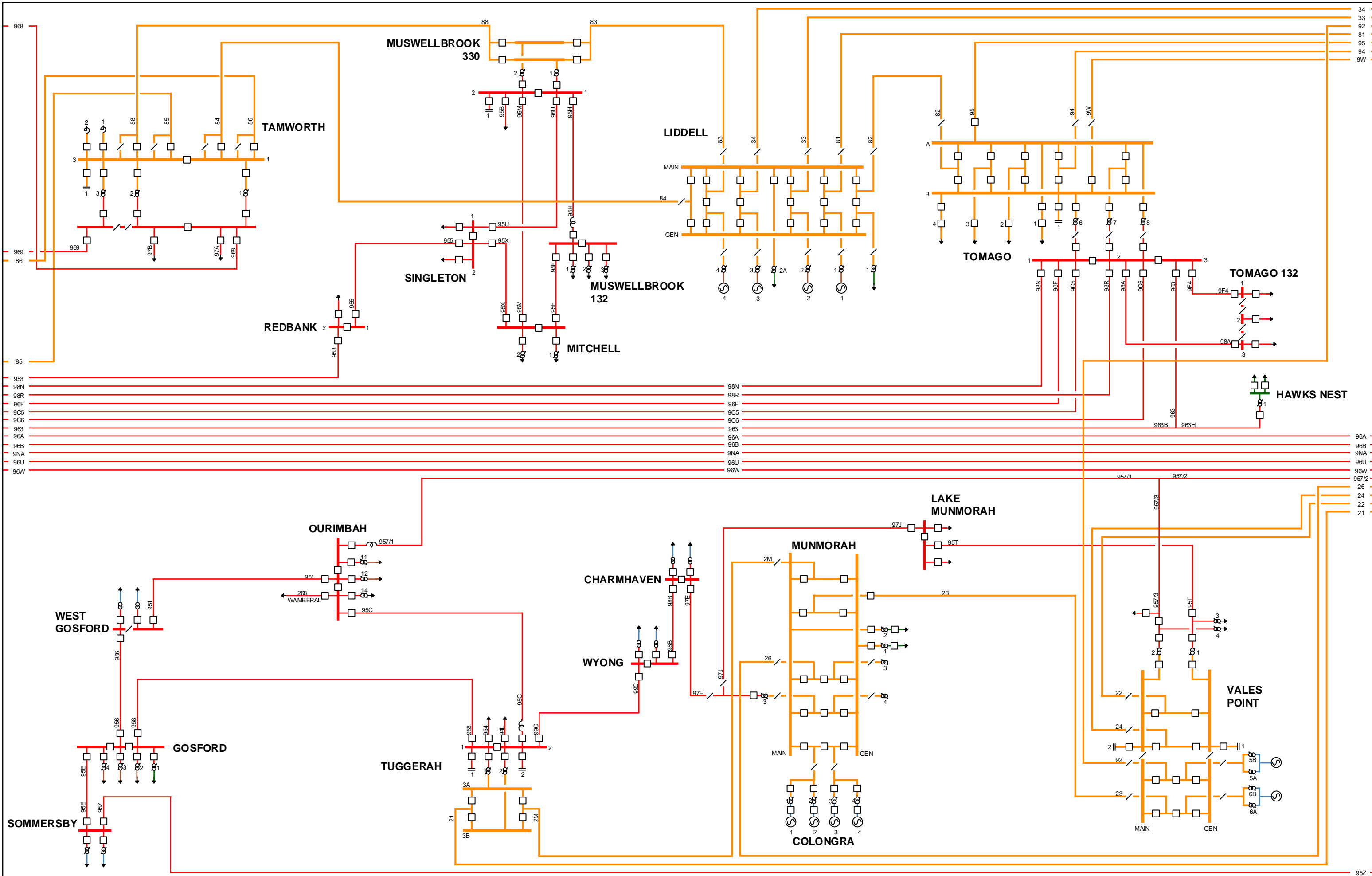

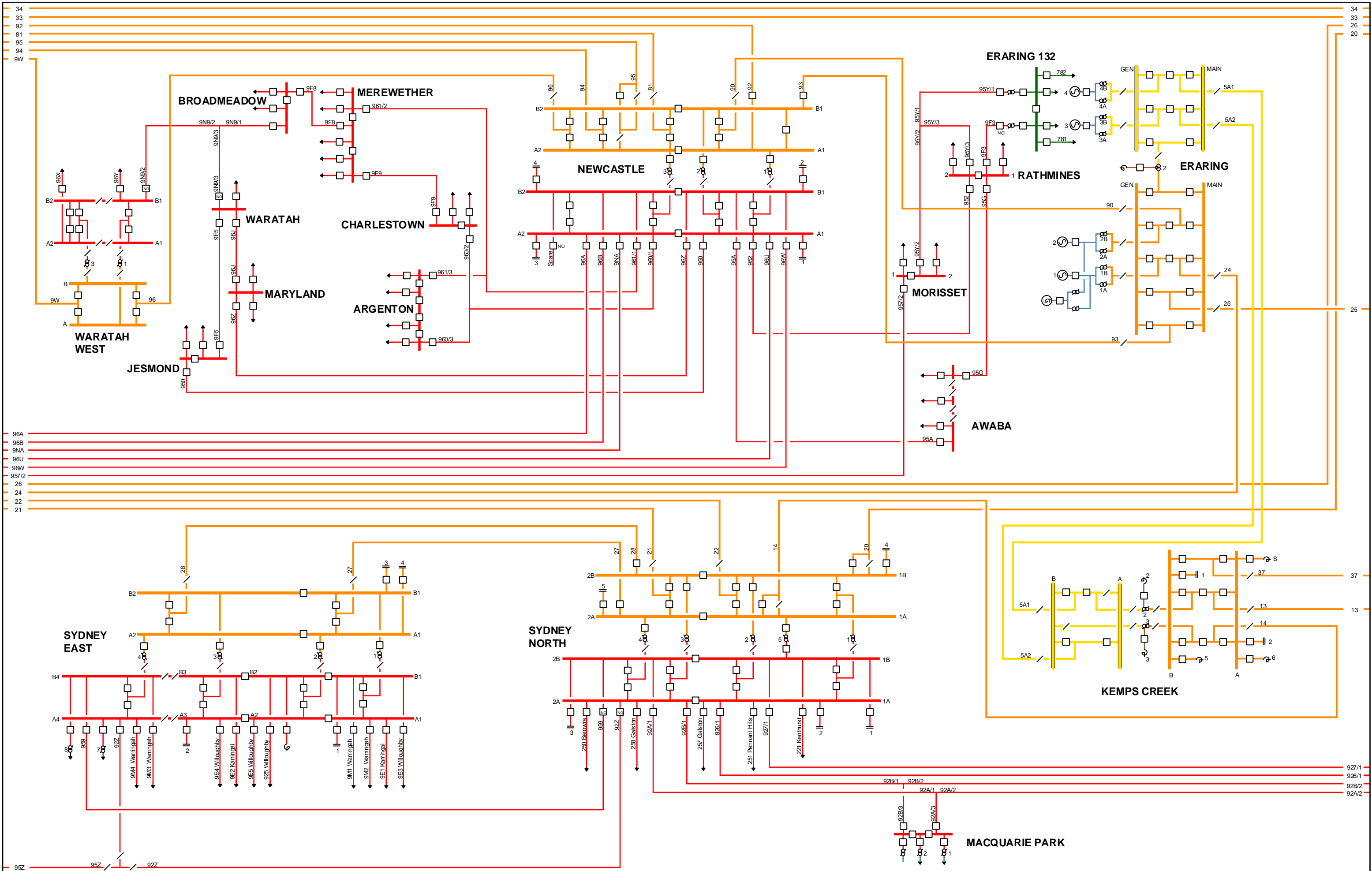



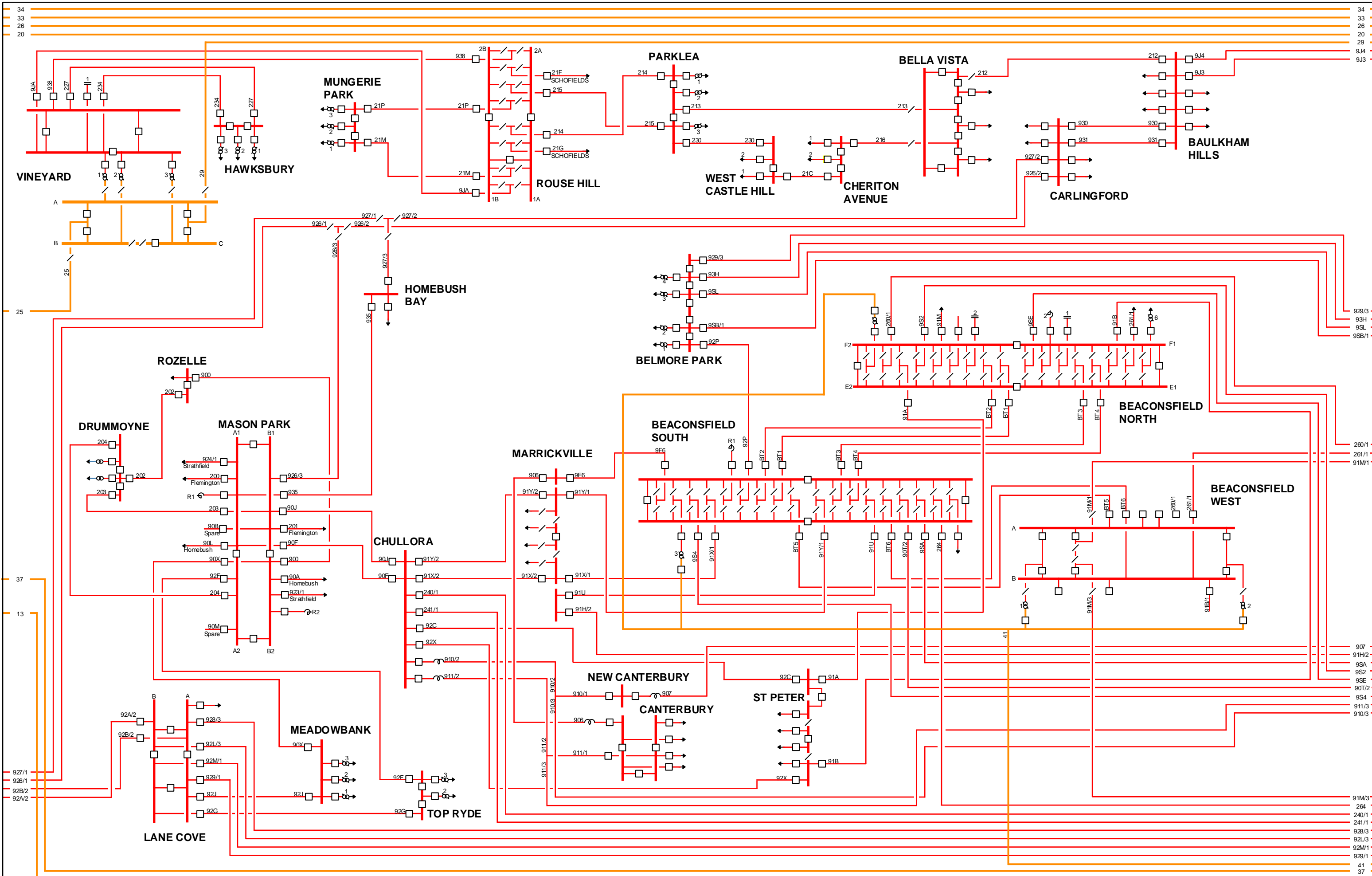

NSW - c	NSW - d	NSW - e
---------	---------	---------

500 kV	Generator	Circuit breaker	Reactor	2 Winding tap transformer	2 Winding fixed tap transformer
330 kV	Wind Farm	Isolator	Series Reactor	3 Winding tap transformer	3 Winding fixed tap transformer
275 kV	Solar Farm	Capacitor Bank	Auto transformer		
220 kV	Static Var Compensator	Synchronous Condenser			
132 / 110 kV					
66 kV					
33 kV					
22 kV					

This diagram is intended to be a high-level representation only, interested parties should always consult with their relevant transmission network service provider (or equivalent) for more accurate information.

DATE: 14-10-2016

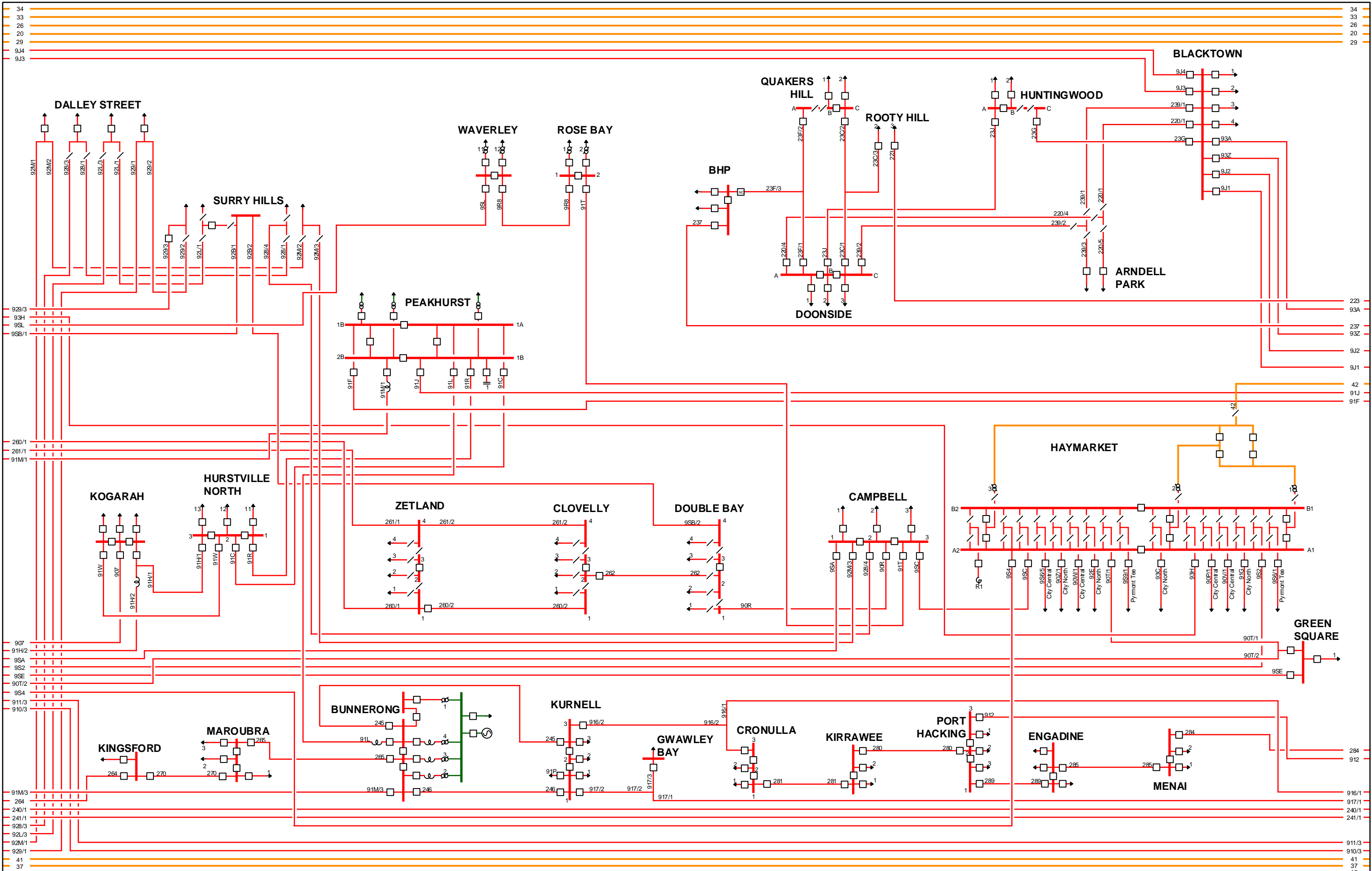

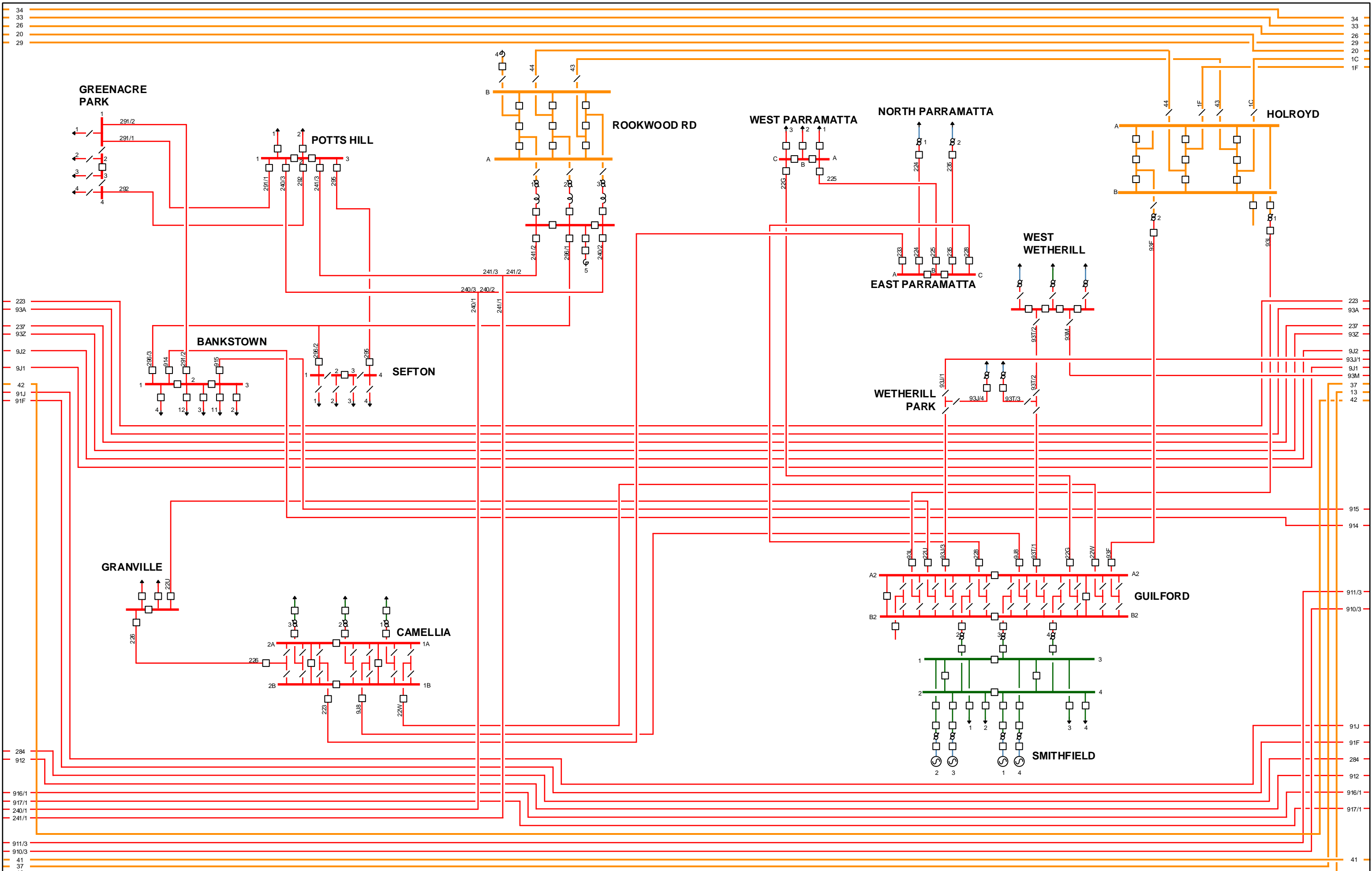

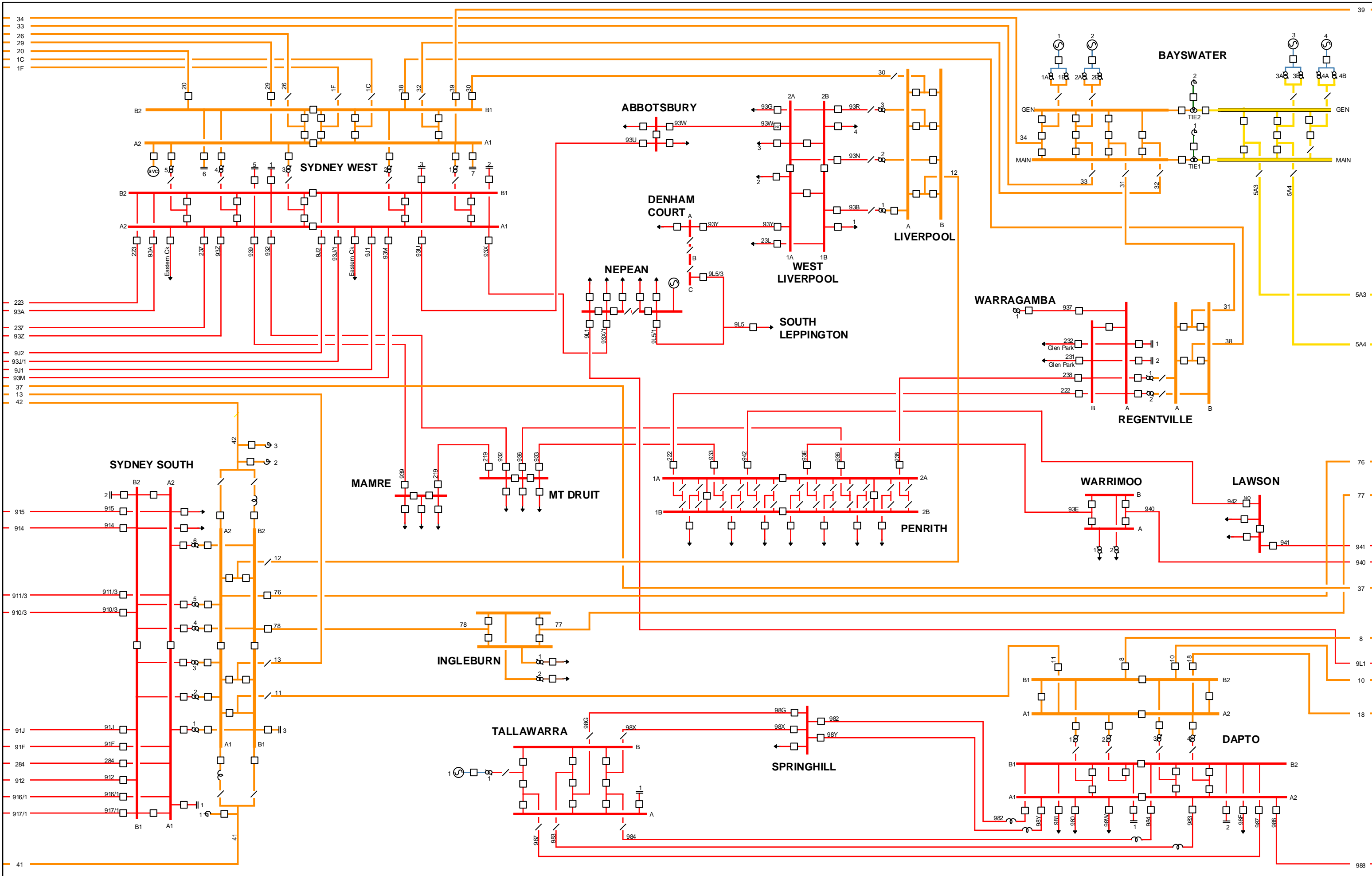

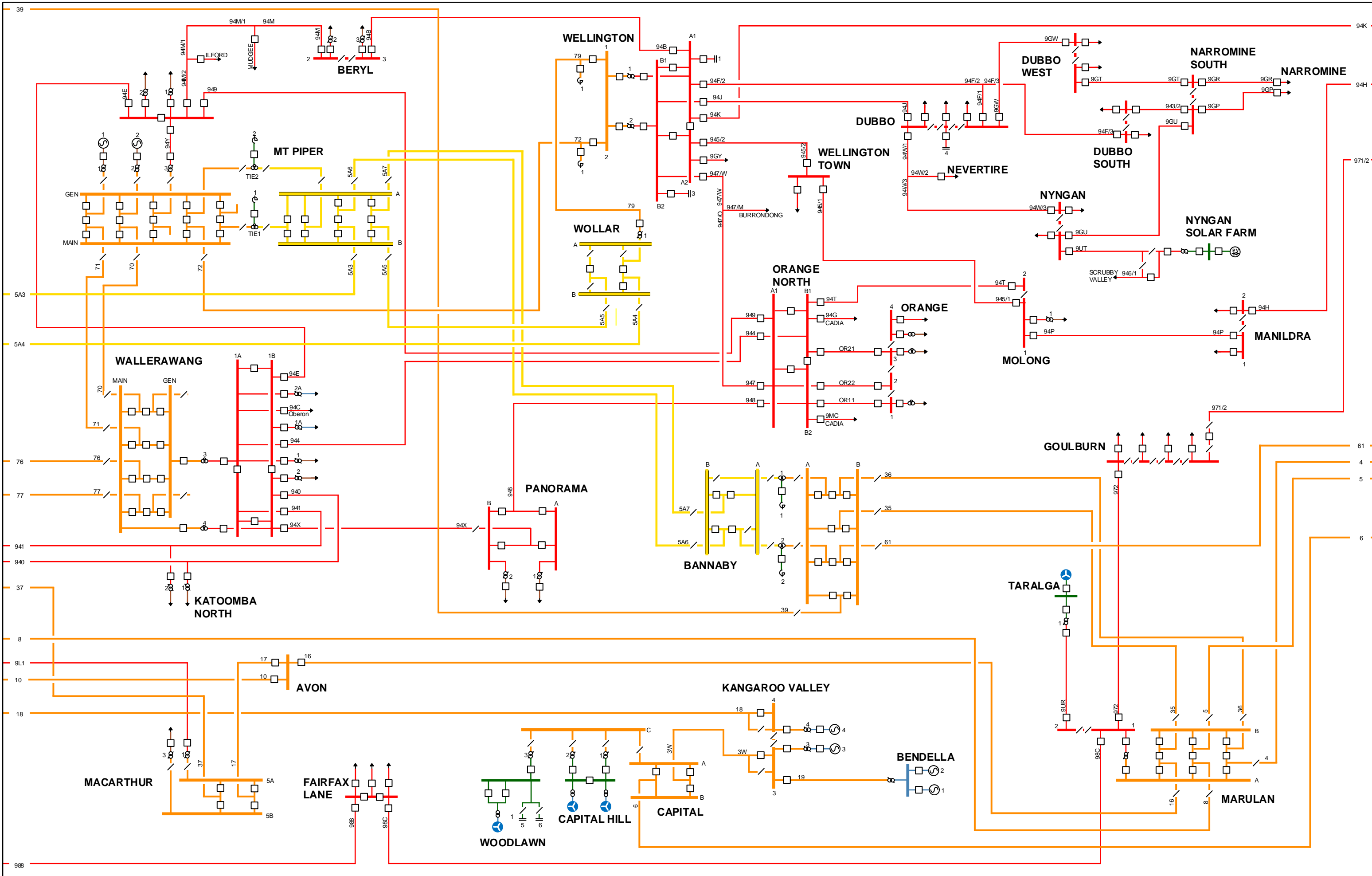

NSW - g	NSW - h	NSW - i
---------	---------	---------

500 kV	330 kV	275 kV	220 kV	132 / 110 kV	66 kV	33 kV	22 kV
--------	--------	--------	--------	--------------	-------	-------	-------

Generator	Circuit breaker	Reactor	2 Winding tap transformer	2 Winding fixed tap transformer
Wind Farm	Isolator	Series Reactor	3 Winding tap transformer	3 Winding fixed tap transformer
Solar Farm	Capacitor Bank	Auto transformer		
Static Var Compensator	Synchronous Condenser			

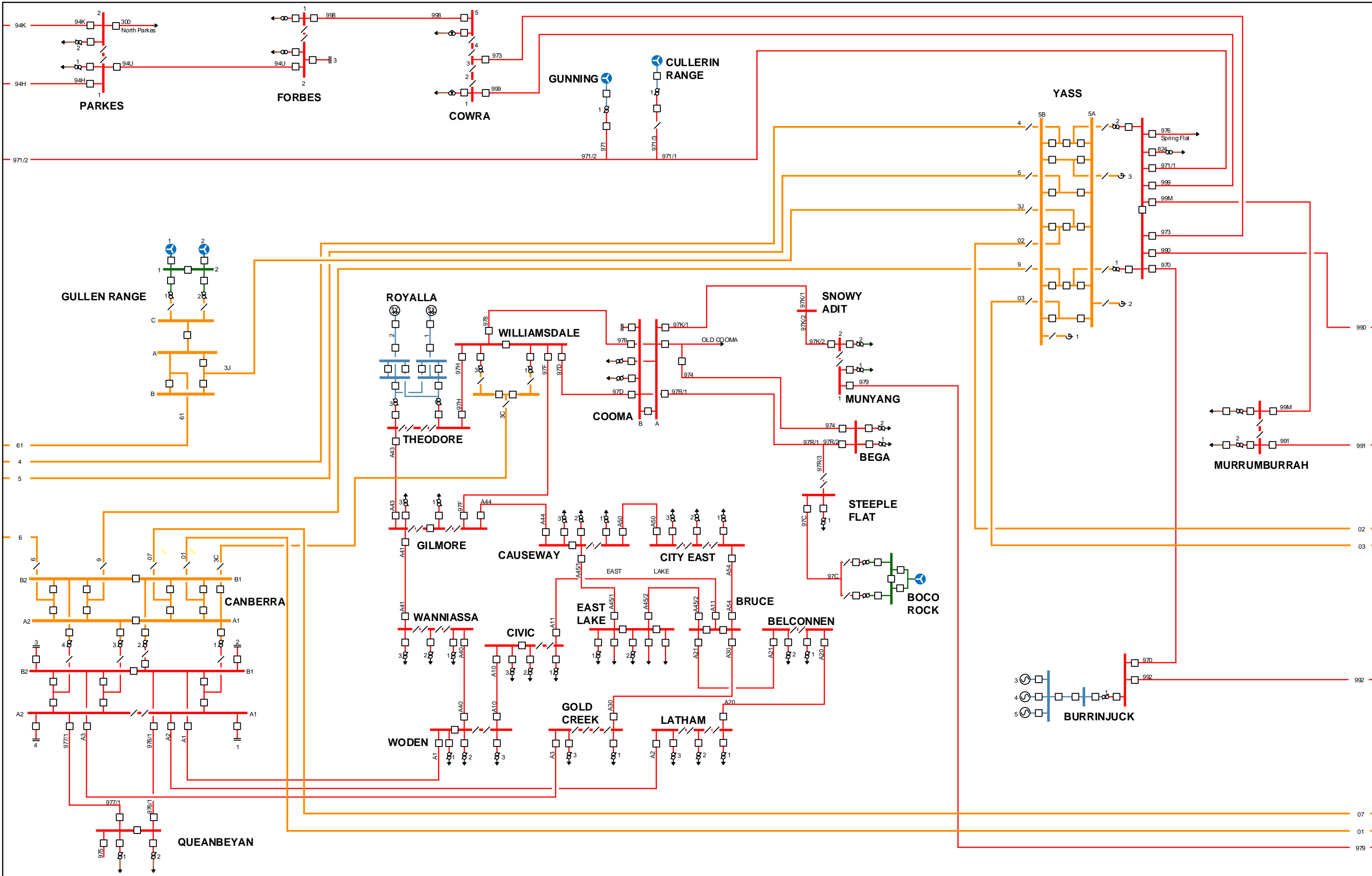

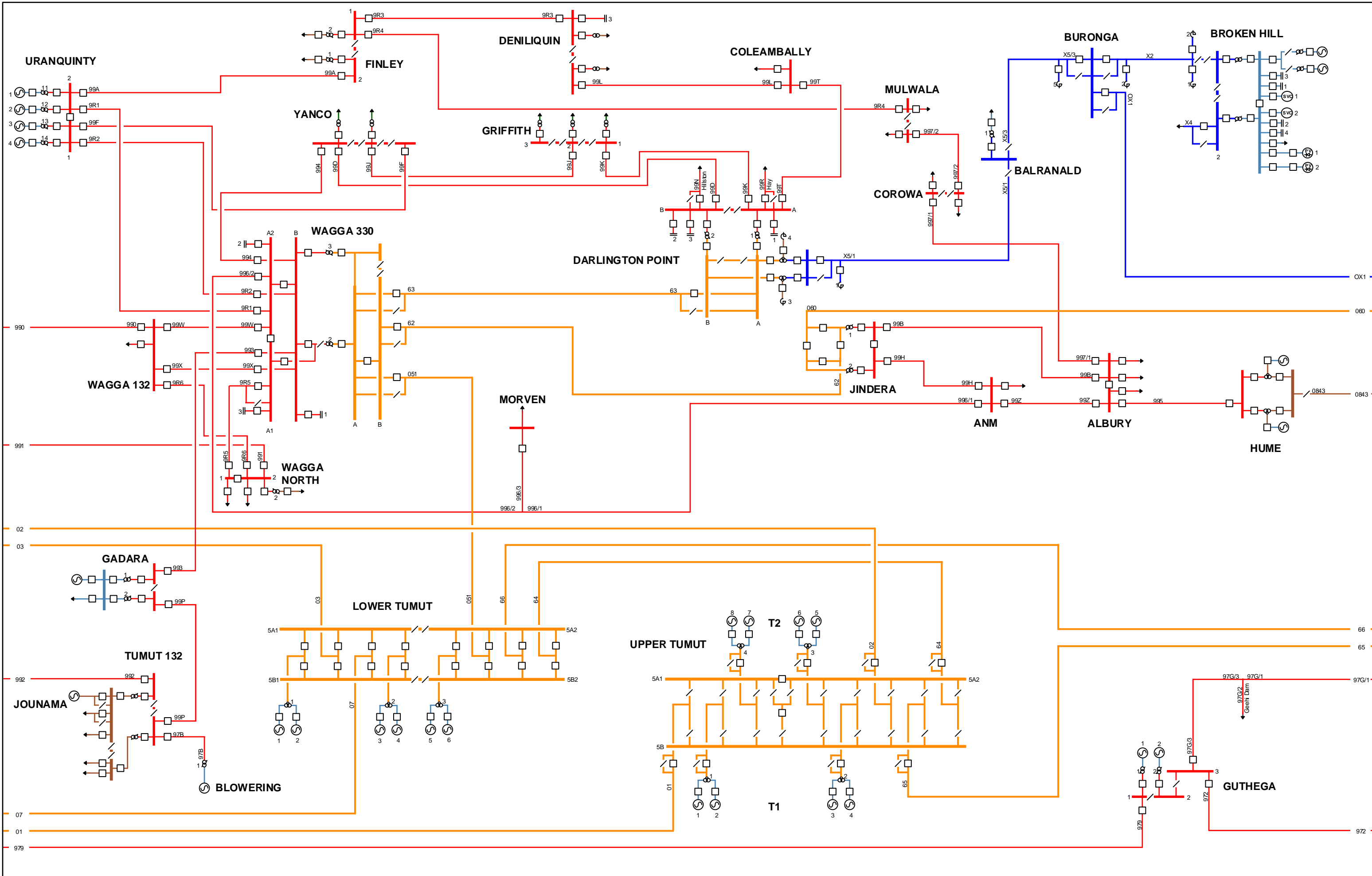

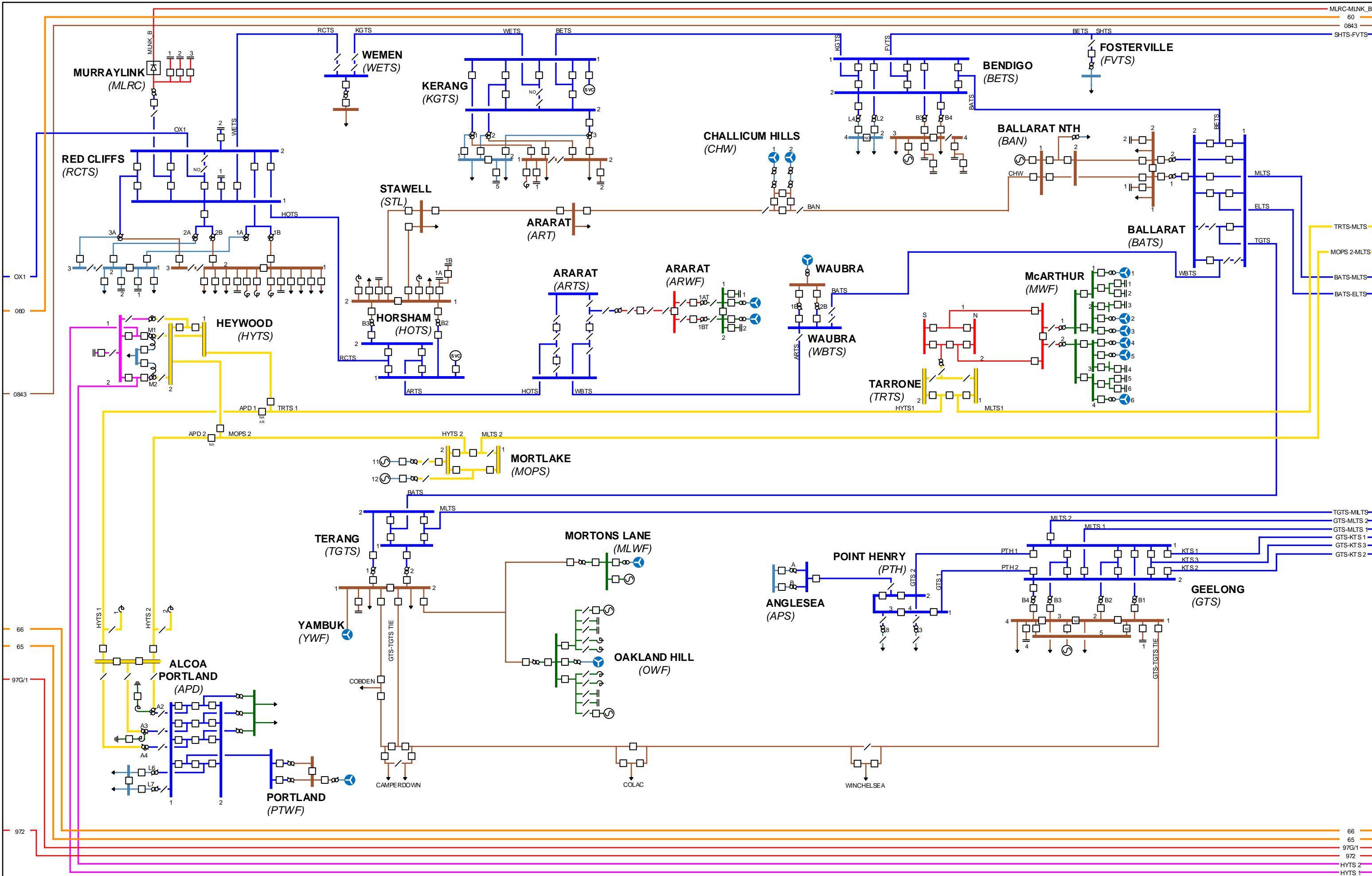



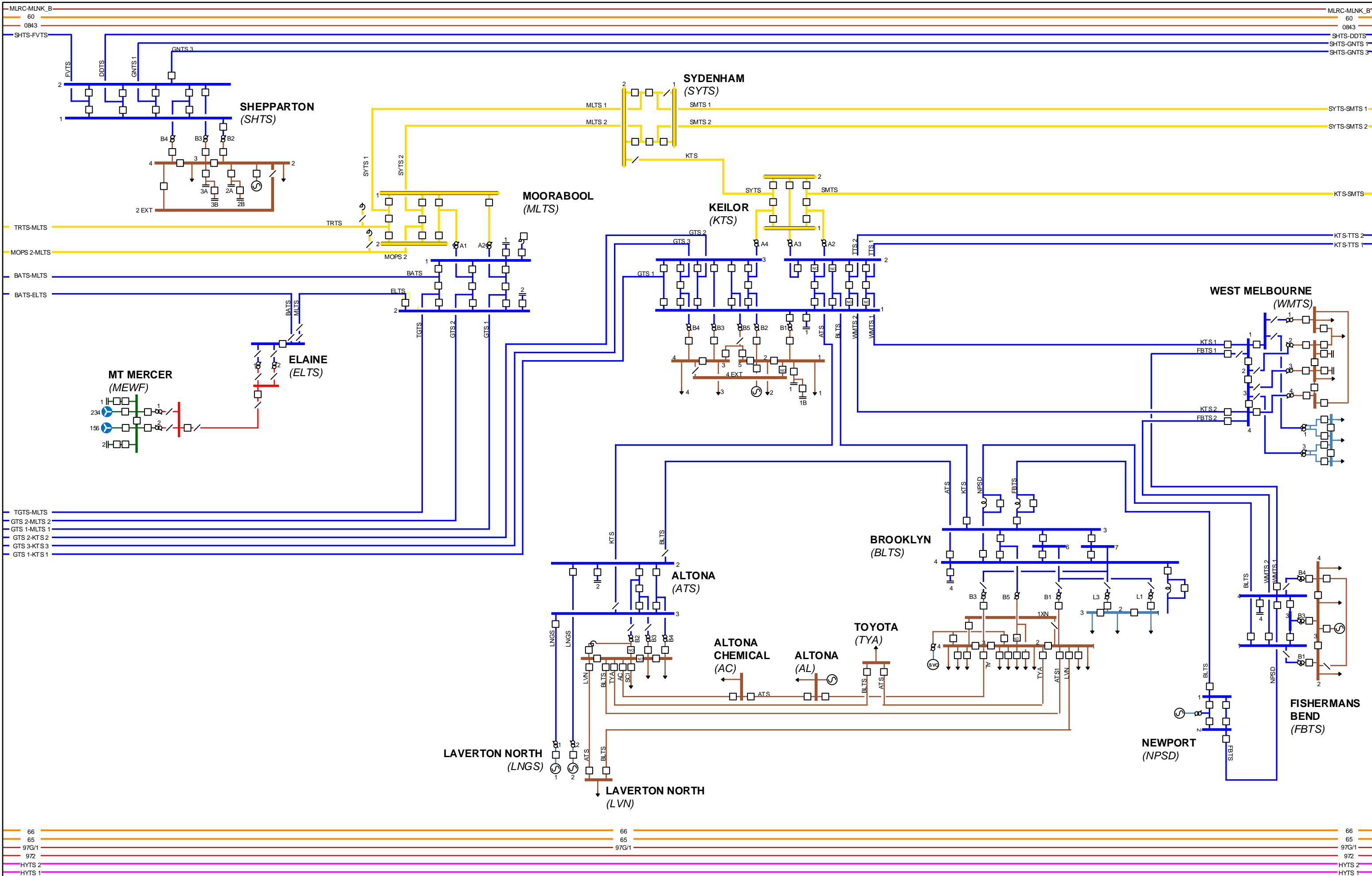

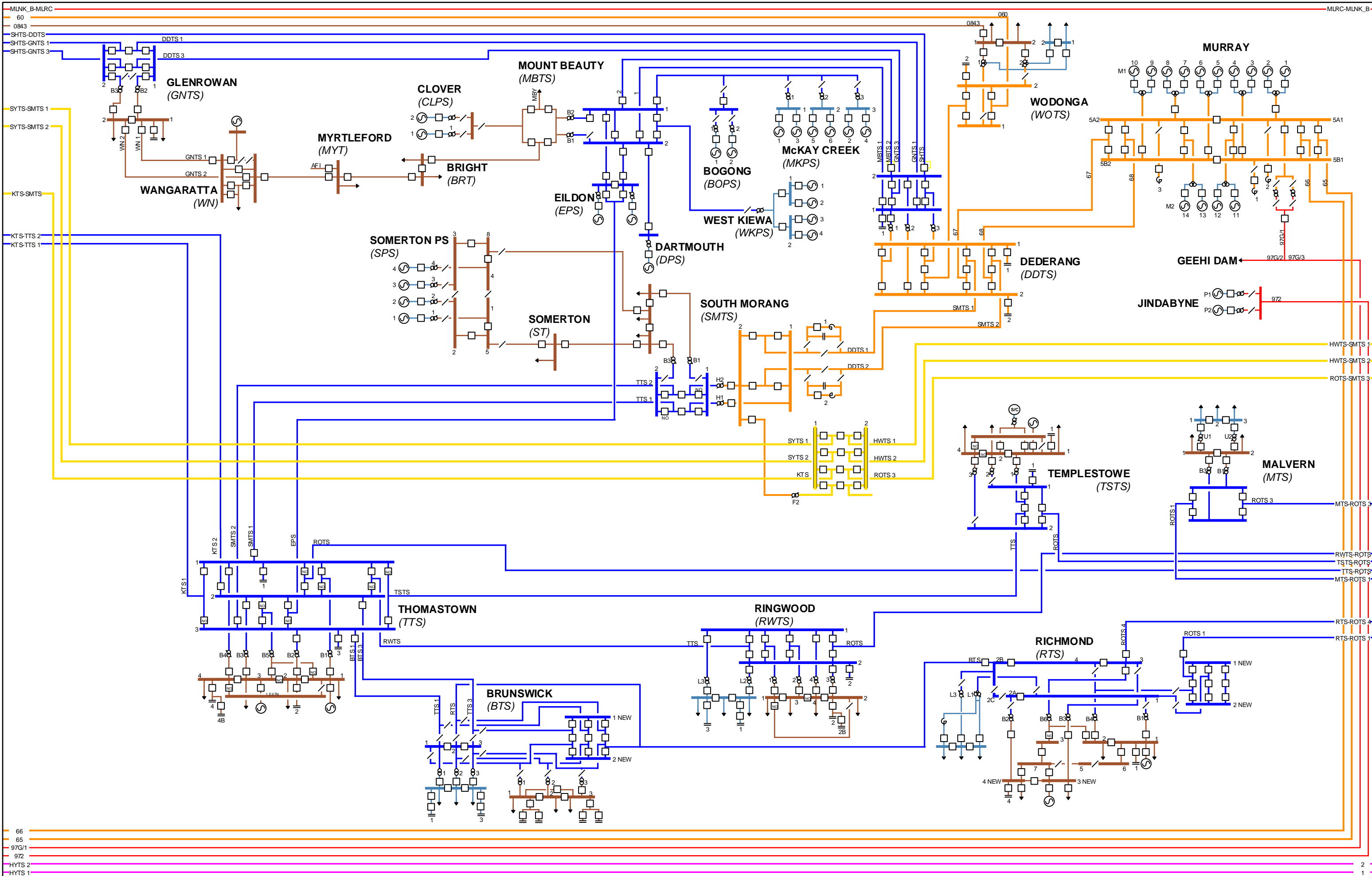

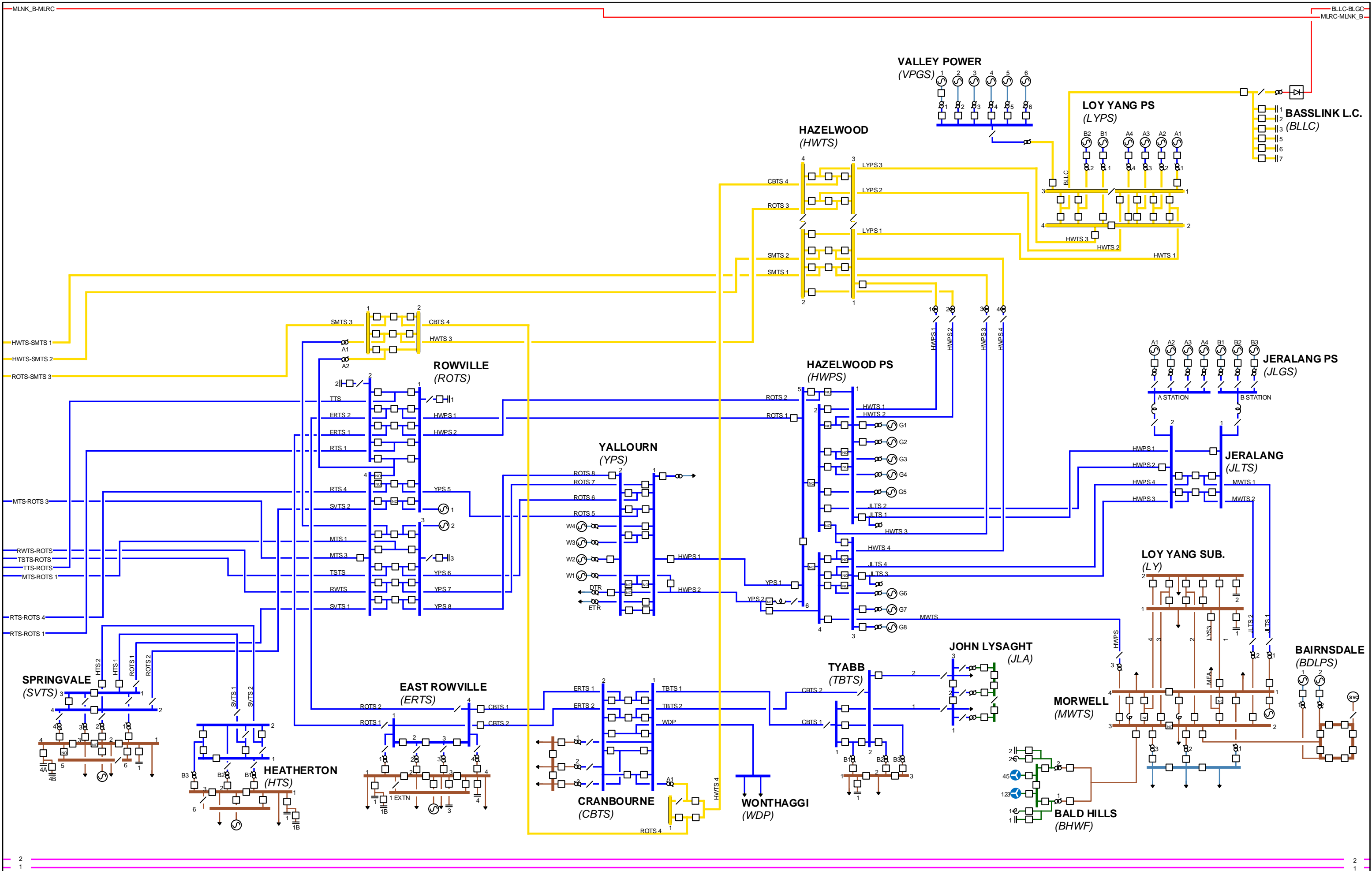

VIC - c	VIC - d	SA - a
---------	---------	--------

500 kV	Generator	Circuit breaker	Reactor	2 Winding tap transformer	2 Winding fixed tap transformer
330 kV	Wind Farm	Isolator	Series Reactor	3 Winding tap transformer	3 Winding fixed tap transformer
275 kV	Static Var Compensator	Capacitor Bank	Auto transformer		
220 kV	Synchronous Condensator				
132 / 110 kV					
66 kV					
33 kV					
22 kV					

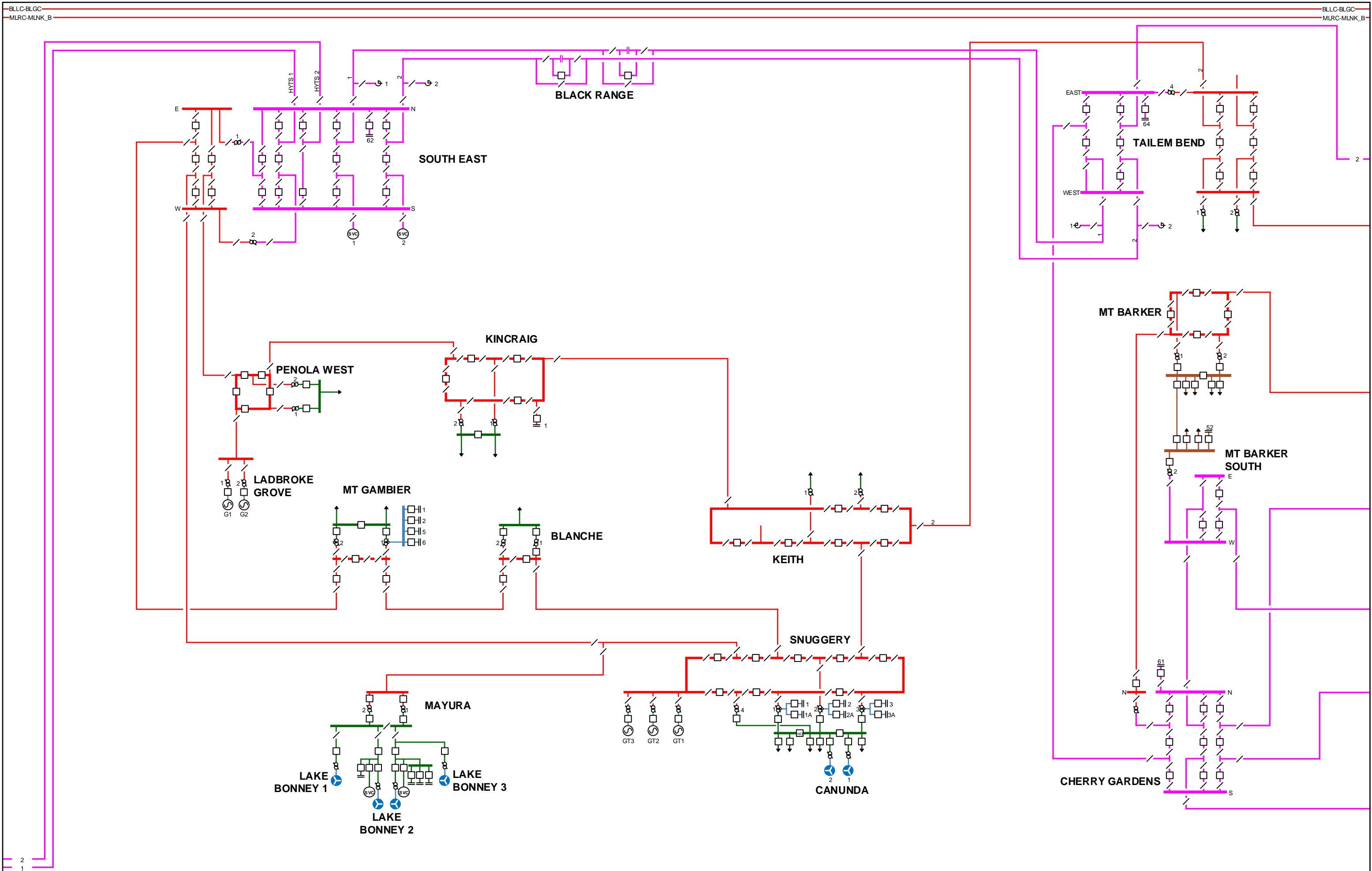

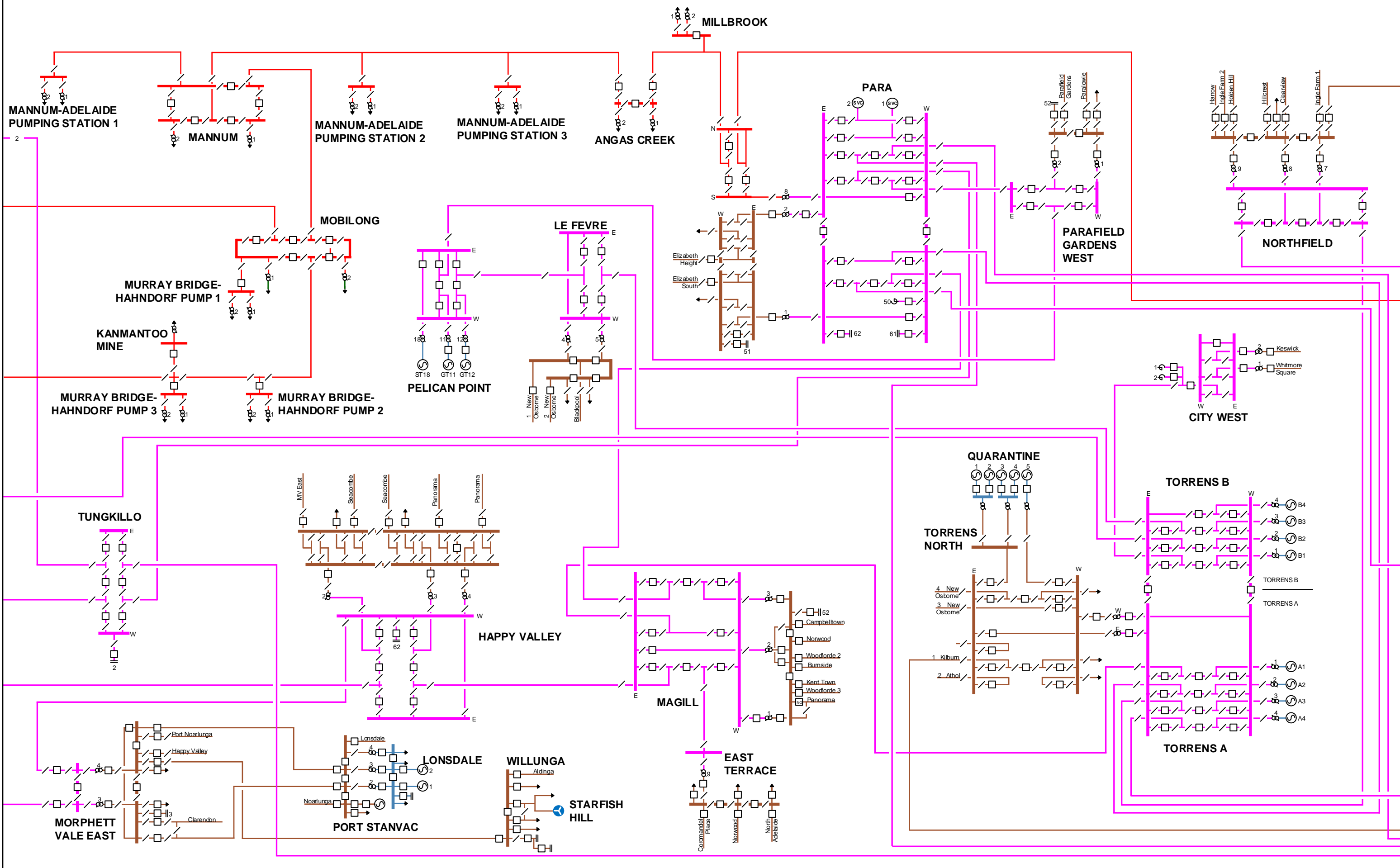

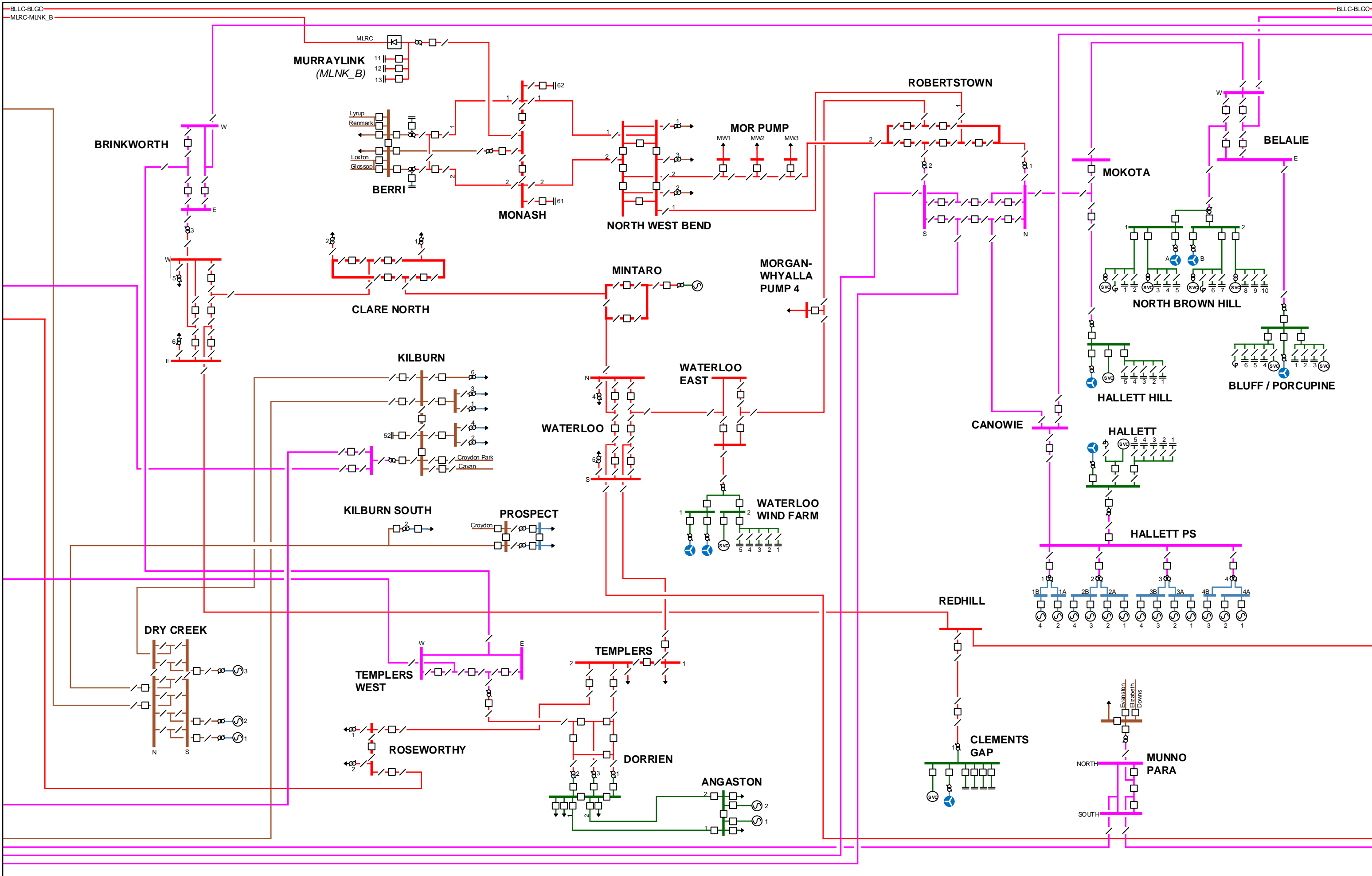

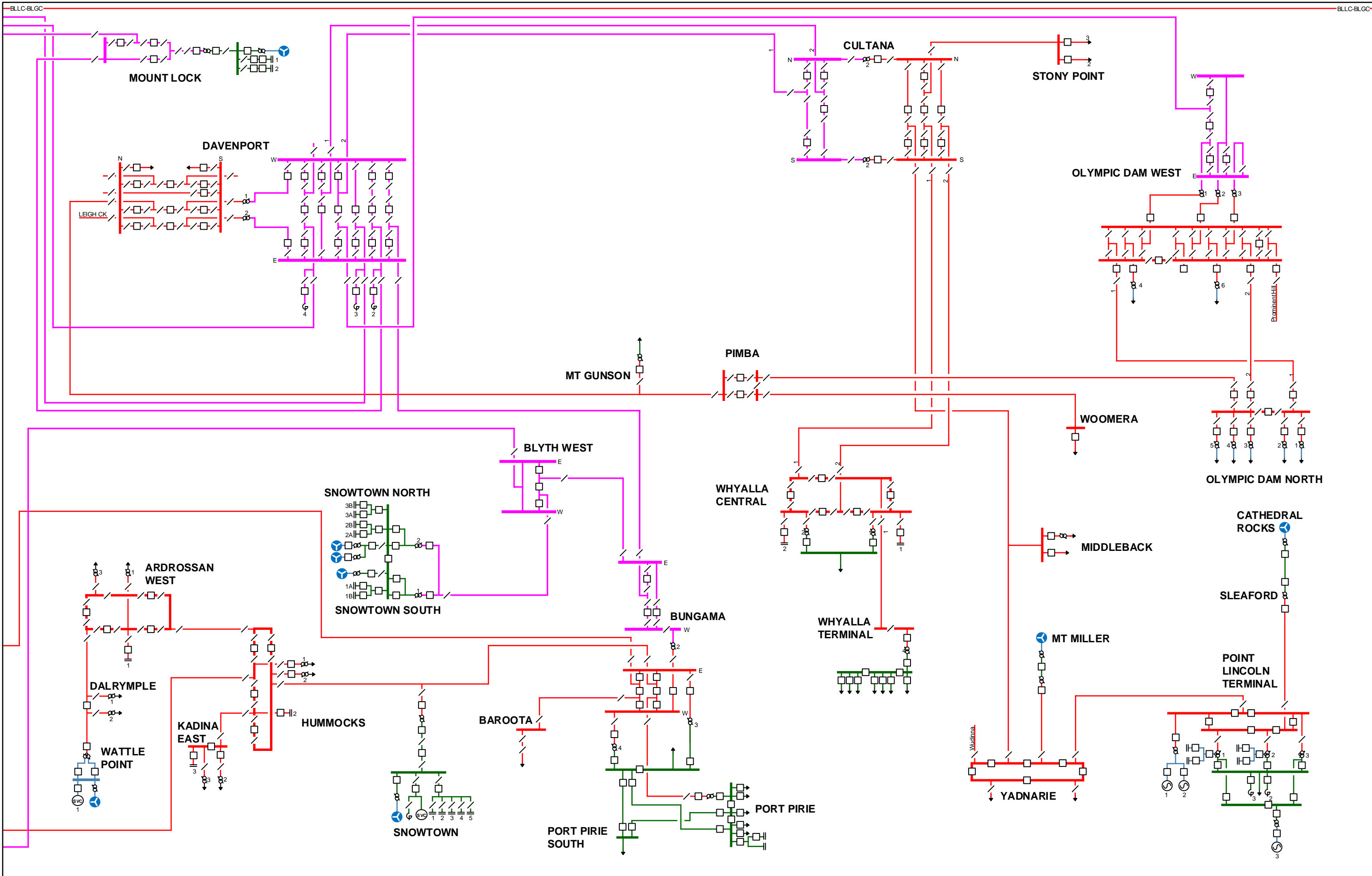

SA - c	SA - d	TAS - a
--------	--------	---------

<ul style="list-style-type: none"> <li><span style="display: inline-block; width: 15px; height: 10px; background-color: yellow; border: 1px solid black;"></span> 500 kV</li> <li><span style="display: inline-block; width: 15px; height: 10px; background-color: orange; border: 1px solid black;"></span> 330 kV</li> <li><span style="display: inline-block; width: 15px; height: 10px; background-color: purple; border: 1px solid black;"></span> 275 kV</li> <li><span style="display: inline-block; width: 15px; height: 10px; background-color: blue; border: 1px solid black;"></span> 220 kV</li> <li><span style="display: inline-block; width: 15px; height: 10px; background-color: red; border: 1px solid black;"></span> 132 / 110 kV</li> <li><span style="display: inline-block; width: 15px; height: 10px; background-color: green; border: 1px solid black;"></span> 66 kV</li> <li><span style="display: inline-block; width: 15px; height: 10px; background-color: lightgreen; border: 1px solid black;"></span> 33 kV</li> <li><span style="display: inline-block; width: 15px; height: 10px; background-color: darkgreen; border: 1px solid black;"></span> 22 kV</li> </ul>	<ul style="list-style-type: none"> <li> Generator</li> <li> Wind Farm</li> <li> Static Var Compensator</li> <li> Synchronous Condensator</li> </ul>	<ul style="list-style-type: none"> <li> Circuit breaker</li> <li> Isolator</li> <li> Capacitor Bank</li> </ul>	<ul style="list-style-type: none"> <li> Reactor</li> <li> Series Reactor</li> </ul>	<ul style="list-style-type: none"> <li> 2 Winding tap transformer</li> <li> 3 Winding tap transformer</li> <li> Auto transformer</li> </ul>	<ul style="list-style-type: none"> <li> 2 Winding fixed tap transformer</li> <li> 3 Winding fixed tap transformer</li> </ul>
--	---	--	---	---	--

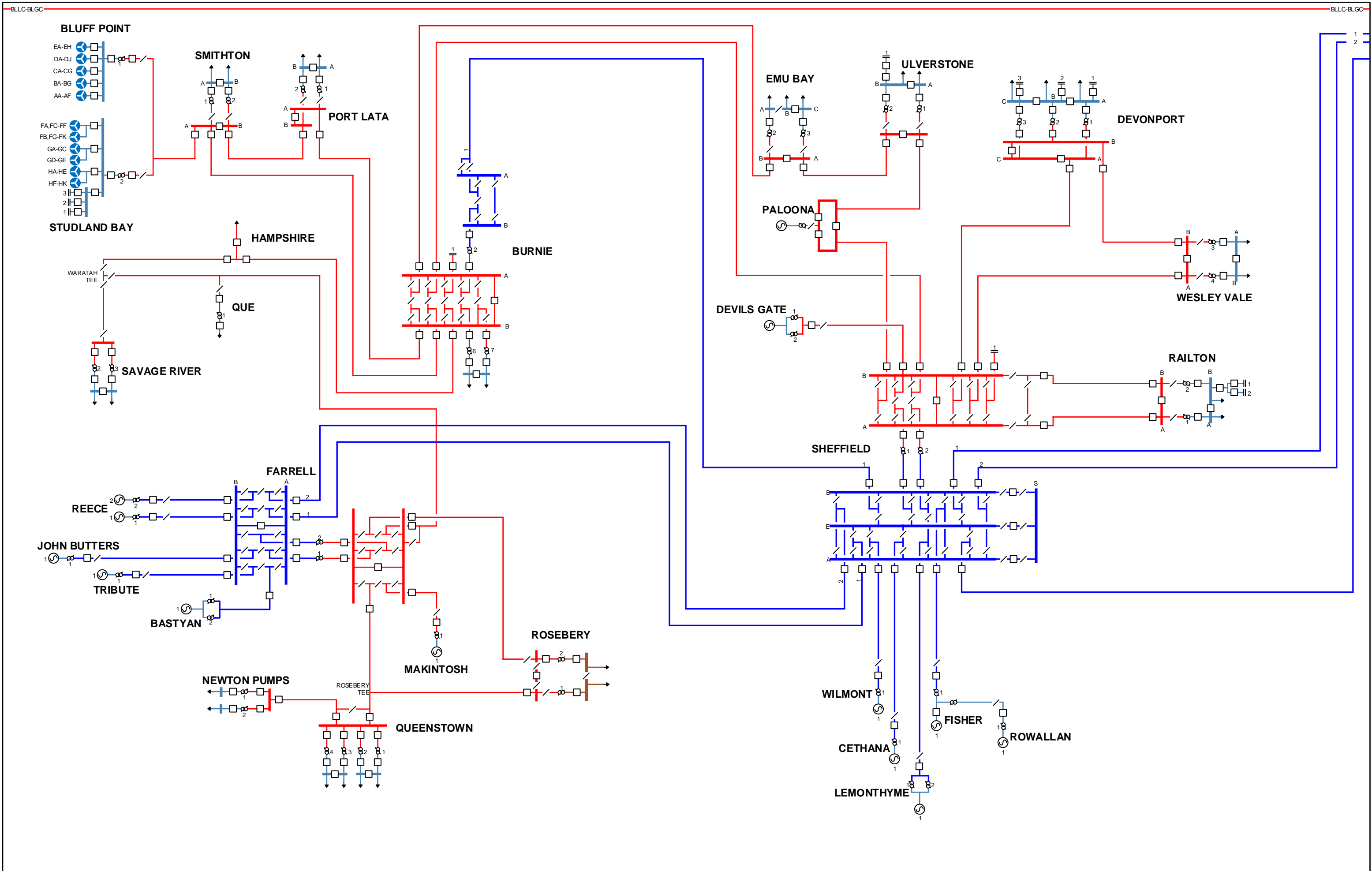



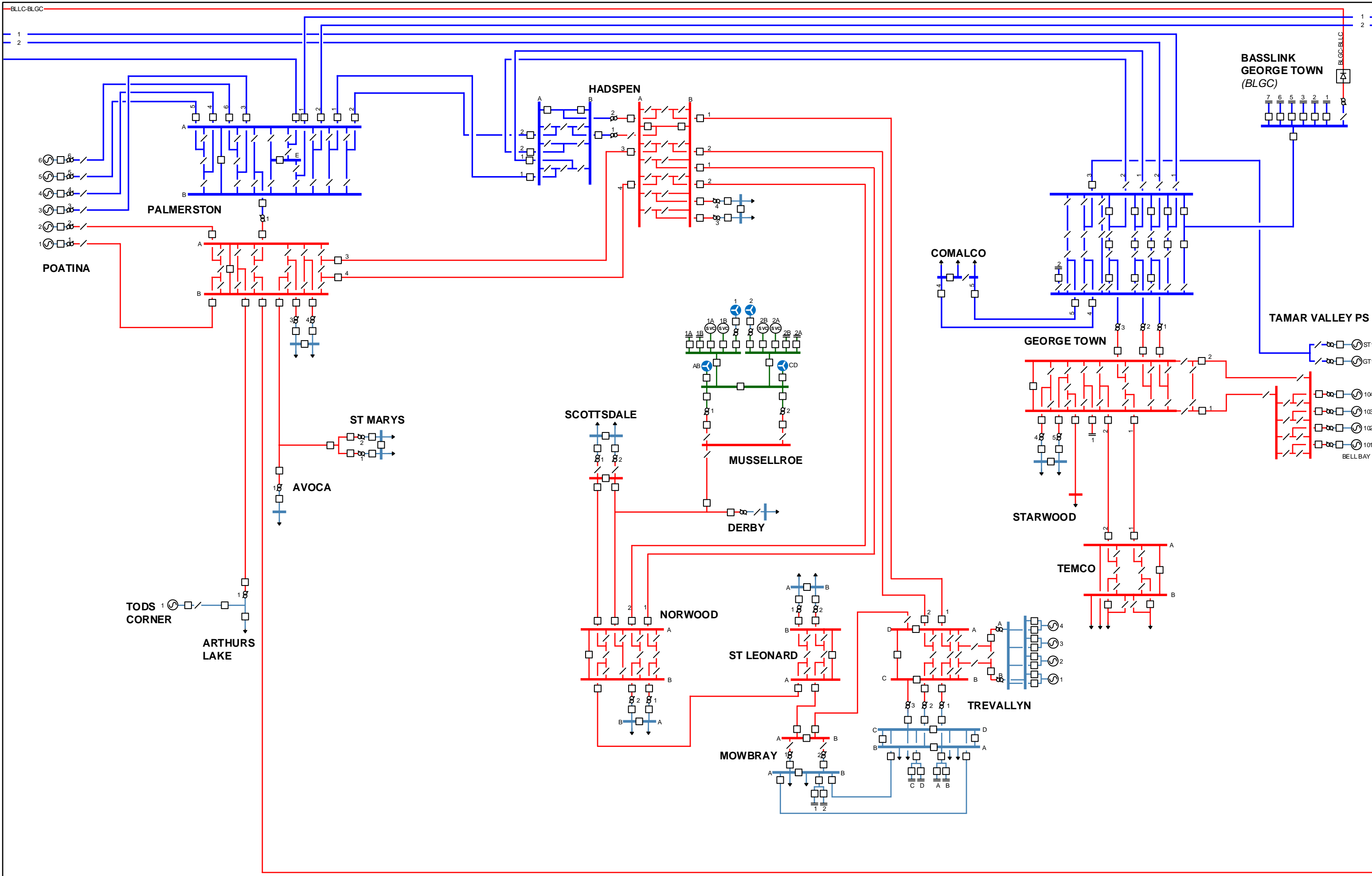

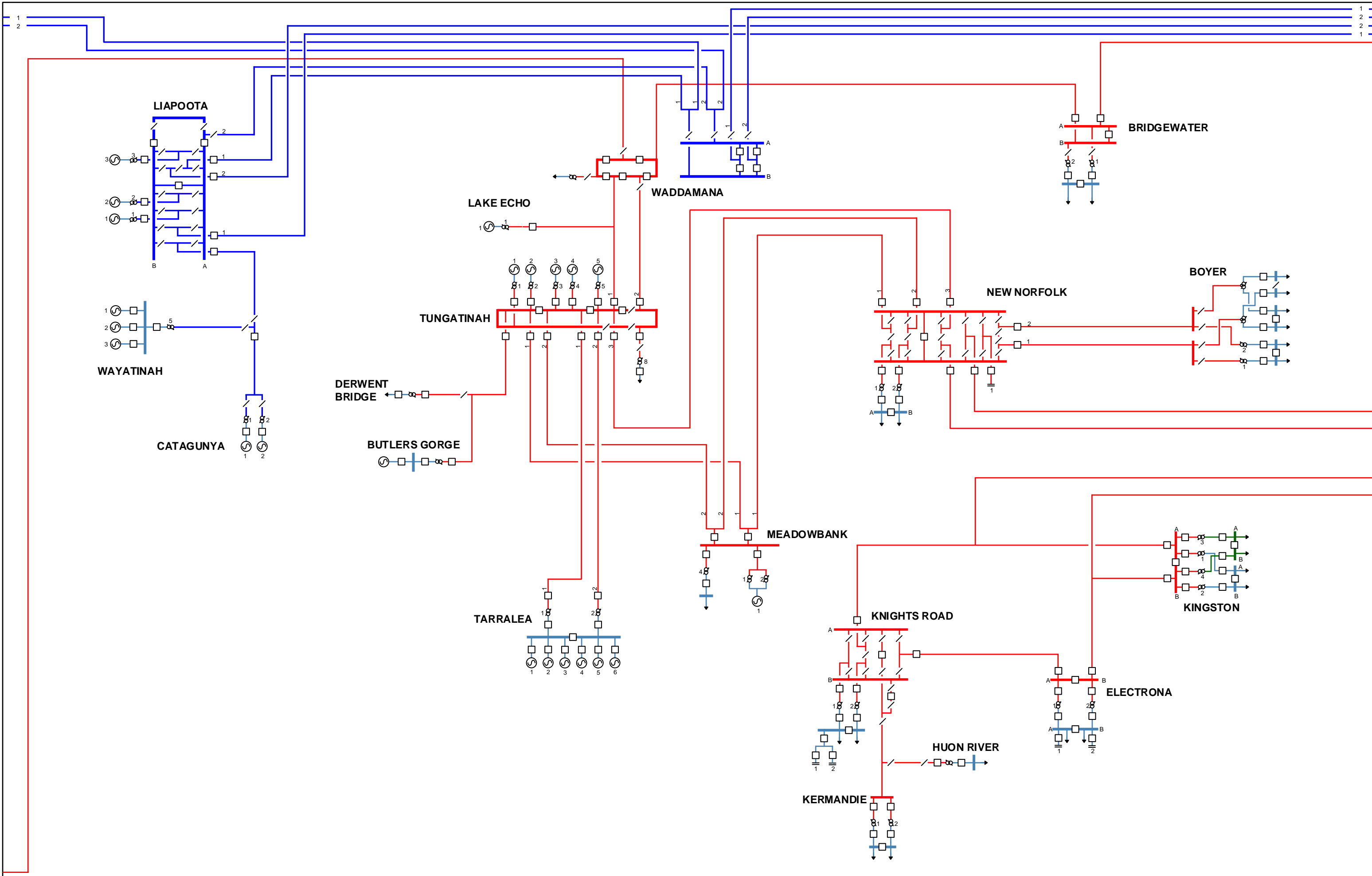

TAS - b	TAS - c	TAS - d
---------	---------	---------

- 500 kV
- 330 kV
- 275 kV
- 220 kV
- 132 / 110 kV
- 66 kV
- 33 kV
- 22 kV

- Generator
- Wind Farm
- Static Var Compensator
- Synchronous Condenser
- Circuit breaker
- Isolator
- Capacitor Bank
- Reactor
- Series Reactor
- 2 Winding tap transformer
- 3 Winding tap transformer
- Auto transformer
- 2 Winding fixed tap transformer
- 3 Winding fixed tap transformer

