

TAMA

DRUMS AND HARDWARE



TABLE OF CONTENTS

4-9	STAR Drums
10-23	Starclassic
24-27	S.L.P. Drum Kits
28-29	Superstar Hyper-Drive Duo
30-33	Superstar Classic
34-37	Imperialstar
38-39	Club-JAM
40-41	Cocktail-JAM
42-46	Snare Drums
47-48	Drum Pedals
49-50	Hi-hat Stands
50-51	Drum Thrones
51-52	Snare Stands
53-54	Cymbal Stands
54-56	Tom Stands & Tom Holders
56-57	Hardware Kits
57-58	Power Tower System
58-62	Clamps & Attachments
63-64	Microphone Stands & Accessories
65-67	TAMA Percussion
67	Practice Tools
68-71	Bags
71-84	Accessories
85-87	Sticks





STAR MAPLE Finish: Ocean Blue Curly Maple -ROLC

TAMA STAR BUBINGA

Lacquer Finishes

STAR is the flagship line for TAMA drums. It takes the knowledge and research we cultivated for the Starclassic series to the next level, by reexamining every detail to enhance shell resonance.

STAR Bubinga features a much thinner shell than Starclassic Bubinga. In addition, every shell comes equipped with 9mm thick Sound Focus Rings (SFR) for structural support. This shell configuration provides clear projection and resonance to highlight the distinct sound of Bubinga.



COLOR Natural Indian Laurel **LNTI**

including:
18"x22" bass drum
7"x10" tom tom
8"x12" tom tom
14"x14" floor tom
16"x16" floor tom
6.5"x14" snare drum



COLOR Dark Green Cordia **CDKG**

including:
14"x18" bass drum
8"x12" tom tom
14"x14" floor tom
5.5"x14" snare drum

INDIVIDUAL MODEL NUMBERS

Diameter	Depth	Model No.		
Bass Drums				
18"	14"	TBB1814S		
18"	15"	TBB1815S		
18"	16"	TBB1816S		
20"	14"	TBB2014S		
20"	16"	TBB2016S		
20"	17"	TBB2017S		
20"	18"	TBB2018S		
22"	14"	TBB2214S		
22"	16"	TBB2216S		
22"	17"	TBB2217S		
22"	18"	TBB2218S		
24"	14"	TBB2414S		
24"	16"	TBB2416S		
24"	17"	TBB2417S		
24"	18"	TBB2418S		
26"	14"	TBB2614S		
26"	16"	TBB2616S		
Floor Toms				
14"	12"	TBF1412S		
14"	13"	TBF1413S		
14"	14"	TBF1414S		
15"	13"	TBF1513S		
15"	14"	TBF1514S		
15"	15"	TBF1515S		
16"	14"	TBF1614S		
16"	15"	TBF1615S		
16"	16"	TBF1616S		
18"	14"	TBF1814S		
18"	15"	TBF1815S		
18"	16"	TBF1816S		

Diameter	Depth	Model No.		
Tom Toms				
8"	6"	TBT0806S		
8"	7"	TBT0807S		
8"	8"	TBT0808S		
10"	6.5"	TBT1065S		
10"	7"	TBT1007S		
10"	8"	TBT1008S		
10"	9"	TBT1009S		
10"	10"	TBT1010S		
12"	7"	TBT1207S		
12"	8"	TBT1208S		
12"	9"	TBT1209S		
12"	10"	TBT1210S		
12"	11"	TBT1211S		
13"	7.5"	TBT1375S		
13"	9"	TBT1309S		
13"	10"	TBT1310S		
13"	11"	TBT1311S		
13"	12"	TBT1312S		
14"	8"	TBT1408S		
14"	10"	TBT1410S		
14"	11"	TBT1411S		
14"	12"	TBT1412S		
14"	13"	TBT1413S		
Snare Drums				
13"	6"	TBS136S		
14"	5.5"	TBS1455S		
14"	6.5"	TBS1465S		
14"	8"	TBS148S		

*Please ask price for "outside & inside inlay" option.

MODEL NUMBER SYSTEM - Individual Drums

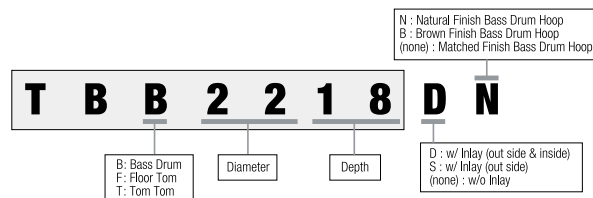

FINISHES (Lacquer)



Dark Green Cordia
CDKG



Dark Red Cordia
CDKR



Satin Natural Cordia
CSTN



Natural Indian Laurel
LNTI



Blue Gray Metallic
BGM



Dark Burgundy Metallic
DBM



Satin Blue Metallic
SBM



Satin Green Metallic
SGM



Antique White
ATW



Smoky Black
SKB



Atomic Orange
AMO



Coral Pink
CRP



Grand Aqua Blue
GAQ



Sunny Yellow Lacquer
SYL



Vintage Sea Blue
VSB

TAMA STAR MAPLE

Lacquer Finishes

STAR is the flagship line for TAMA drums. It takes the knowledge and research we cultivated for the Starclassic series to the next level, by reexamining every detail to enhance shell resonance.

STAR Maple shell's "Solid Core Ply" is a totally new design for this series. This unique shell provides the warm, open tone of Maple, combined with the rich, hearty sound of a solid ply shell.



COLOR Ocean Blue Curly Maple **ROLC**

including:
18"x22" bass drum
7"x10" tom tom
8"x12" tom tom
14"x14" floor tom
16"x16" floor tom
6.5"x14" snare drum



COLOR Raspberry Curly Maple **RRCM**

including:
14"x18" bass drum
8"x12" tom tom
14"x14" floor tom
5.5"x14" snare drum

INDIVIDUAL MODEL NUMBERS

Diameter	Depth	Model No.		
Bass Drums				
18"	14"	TMB1814S		
18"	15"	TMB1815S		
18"	16"	TMB1816S		
20"	14"	TMB2014S		
20"	16"	TMB2016S		
20"	17"	TMB2017S		
20"	18"	TMB2018S		
22"	14"	TMB2214S		
22"	16"	TMB2216S		
22"	17"	TMB2217S		
22"	18"	TMB2218S		
24"	14"	TMB2414S		
24"	16"	TMB2416S		
24"	17"	TMB2417S		
24"	18"	TMB2418S		
26"	14"	TMB2614S		
26"	16"	TMB2616S		
Floor Toms				
14"	12"	TMF1412S		
14"	13"	TMF1413S		
14"	14"	TMF1414S		
15"	13"	TMF1513S		
15"	14"	TMF1514S		
15"	15"	TMF1515S		
16"	14"	TMF1614S		
16"	15"	TMF1615S		
16"	16"	TMF1616S		
18"	14"	TMF1814S		
18"	15"	TMF1815S		
18"	16"	TMF1816S		

*Please ask price for "outside & inside inlay" option.

Diameter	Depth	Model No.		
Tom Toms				
8"	6"	TMT0806S		
8"	7"	TMT0807S		
8"	8"	TMT0808S		
10"	6.5"	TMT1065S		
10"	7"	TMT1007S		
10"	8"	TMT1008S		
10"	9"	TMT1009S		
10"	10"	TMT1010S		
12"	7"	TMT1207S		
12"	8"	TMT1208S		
12"	9"	TMT1209S		
12"	10"	TMT1210S		
12"	11"	TMT1211S		
13"	7.5"	TMT1375S		
13"	9"	TMT1309S		
13"	10"	TMT1310S		
13"	11"	TMT1311S		
13"	12"	TMT1312S		
14"	8"	TMT1408S		
14"	10"	TMT1410S		
14"	11"	TMT1411S		
14"	12"	TMT1412S		
14"	13"	TMT1413S		
Snare Drums				
13"	6"	TMS136S		
14"	5.5"	TMS1455S		
14"	6.5"	TMS1465S		
14"	8"	TMS148S		

MODEL NUMBER SYSTEM - Individual Drums

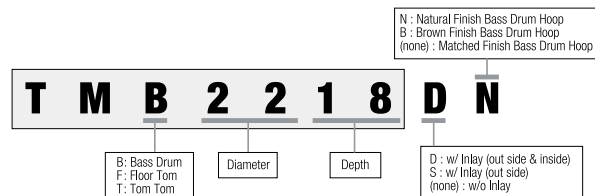

FINISHES (Lacquer)

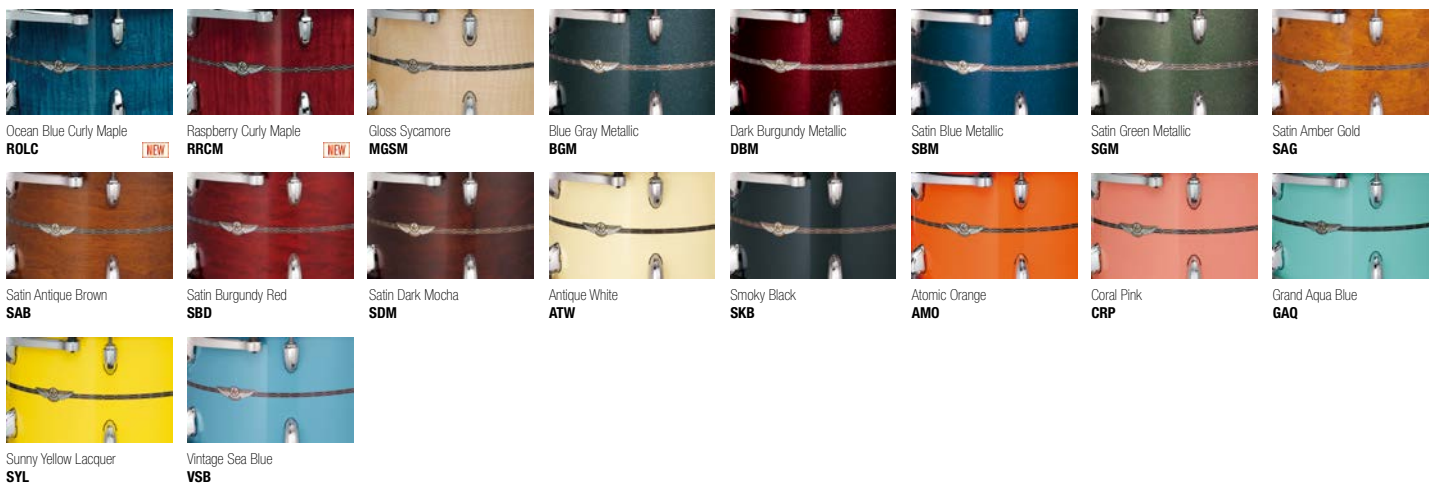

TAMA STAR WALNUT

Lacquer Finishes

STAR is the flagship line for TAMA drums. It takes the knowledge and research we cultivated for the Starclassic series to the next level, by reexamining every detail to enhance shell resonance.

Walnut has long been favored by furniture makers for both its beauty and durability. As a drum shell material, Walnut's naturally EQ'ed tone has been praised by the drum community for both the stage and the studio. The STAR Walnut shells project booming low end with enough cut to be heard through any mix.



COLOR Indigo Japanese Sen Burst AIJB

TW42ZS basic kit

including:
 18"x22" bass drum
 8"x10" tom tom
 9"x12" tom tom
 14"x16" floor tom

[add-on]
 6.5"x14" snare drum

KIT CONFIGURATIONS LIST

[4pc Shell Kit]

TW42ZS

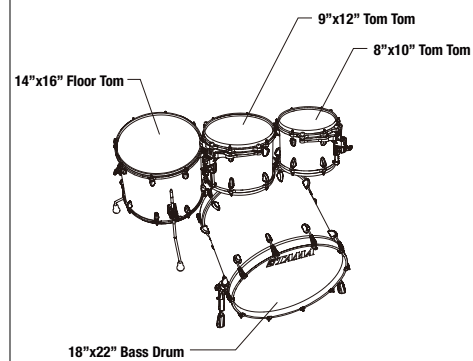

[5pc Shell Kit]

TW52ZS

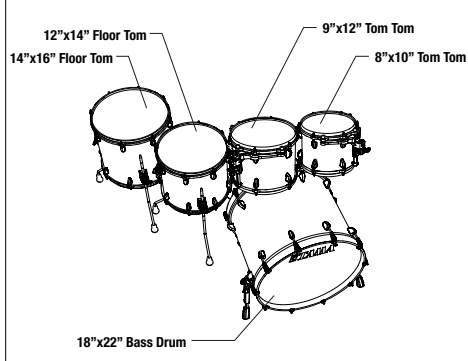

INDIVIDUAL MODEL NUMBERS

Diameter	Depth	Model No.		
Bass Drums				
18"	14"	TWB1814		
18"	15"	TWB1815		
18"	16"	TWB1816		
20"	14"	TWB2014		
20"	16"	TWB2016		
20"	17"	TWB2017		
20"	18"	TWB2018		
22"	14"	TWB2214		
22"	16"	TWB2216		
22"	17"	TWB2217		
22"	18"	TWB2218		
24"	14"	TWB2414		
24"	16"	TWB2416		
24"	17"	TWB2417		
24"	18"	TWB2418		
26"	14"	TWB2614		
26"	16"	TWB2616		
Floor Toms				
14"	12"	TWF1412		
14"	13"	TWF1413		
14"	14"	TWF1414		
15"	13"	TWF1513		
15"	14"	TWF1514		
15"	15"	TWF1515		
16"	14"	TWF1614		
16"	15"	TWF1615		
16"	16"	TWF1616		
18"	14"	TWF1814		
18"	15"	TWF1815		
18"	16"	TWF1816		

Diameter	Depth	Model No.		
Tom Toms				
8"	6"	TWT0806		
8"	7"	TWT0807		
8"	8"	TWT0808		
10"	6.5"	TWT1065		
10"	7"	TWT1007		
10"	8"	TWT1008		
10"	9"	TWT1009		
10"	10"	TWT1010		
12"	7"	TWT1207		
12"	8"	TWT1208		
12"	9"	TWT1209		
12"	10"	TWT1210		
12"	11"	TWT1211		
13"	7.5"	TWT1375		
13"	9"	TWT1309		
13"	10"	TWT1310		
13"	11"	TWT1311		
13"	12"	TWT1312		
14"	8"	TWT1408		
14"	10"	TWT1410		
14"	11"	TWT1411		
14"	12"	TWT1412		
14"	13"	TWT1413		
Snare Drums				
13"	6"	TWS136		
14"	5.5"	TWS1455		
14"	6.5"	TWS1465		
14"	8"	TWS148		

MODEL NUMBER SYSTEM - Individual Drums

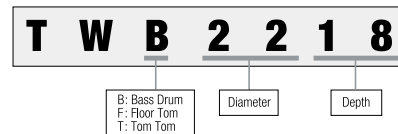

FINISHES (Lacquer)

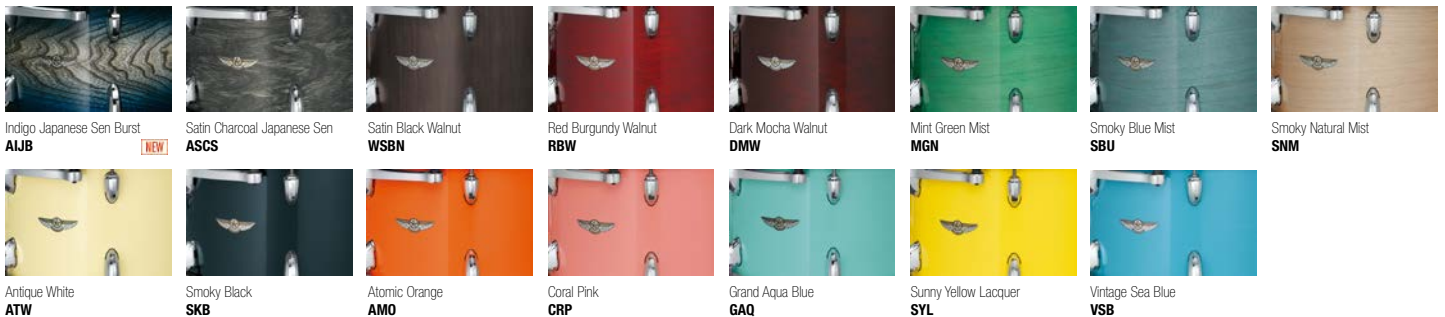

STARCLASSIC BUBINGA

Exotic Finishes

Our Starclassic Bubinga offerings now include an Exotic Finish line which feature extraordinarily beautiful exotic wood finishes, in addition to the regular lacquer finishes. Their shells are made slightly thicker than those in our Starclassic Maple series to provide a more aggressive attack, a fuller deep and dark tone, and more powerful resonance. Numerous options are available to meet the varied and critical needs of professional drummers including a selection of more than 30 different shell sizes. Starclassic Bubinga also features three shell hardware finishes to choose from: Black Nickel, Chrome and Smoked Black Nickel. Starclassic Bubinga is simply an unprecedented combination of sight and sound.



COLOR Crimson Tigerwood Fade **TCGF**
w/ smoked black nickel hardware

BE52ZUS basic kit

including:
18"x22" bass drum
8"x10" tom tom
9"x12" tom tom
12"x14" floor tom
14"x16" floor tom

[add-on]
6.5"x14" snare drum

KIT CONFIGURATIONS LIST

[3pc Shell Kit]

BE32RZS w/Chrome Hardware
BE32RZBS w/ Black Nickel Hardware
BE32RZUS w/ Smoked Black Nickel Hardware

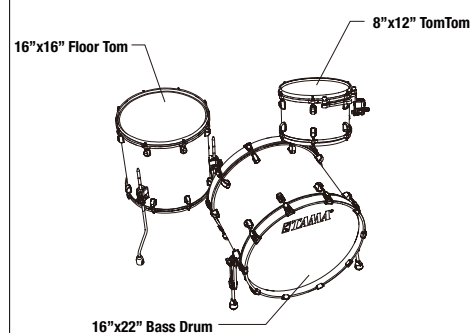

[4pc Shell Kit]

BE42ZS w/Chrome Hardware
BE42ZBS w/ Black Nickel Hardware
BE42ZUS w/ Smoked Black Nickel Hardware

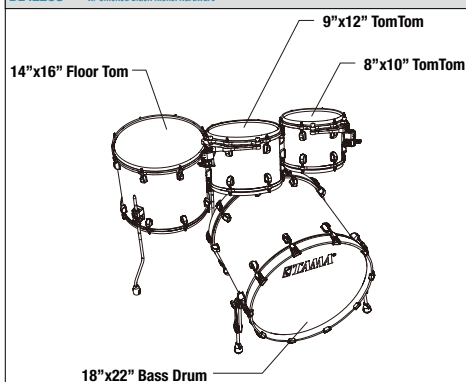

[5pc Shell Kit]

BE52ZS w/Chrome Hardware
BE52ZBS w/ Black Nickel Hardware
BE52ZUS w/ Smoked Black Nickel Hardware

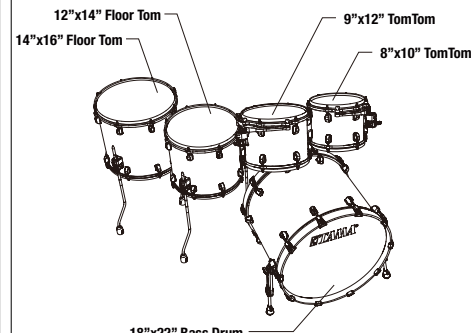

INDIVIDUAL MODEL NUMBERS

Diameter	Depth	Model No.				
		Black Nickel	Chrome	Smoked Black Nickel		
Bass Drums *To order Bass Drum w/ Tom Holder Base, please substitute "Z" with "M". Ex BEB2218Z → BEB2218M						
18"	14"	BEB1814ZB	BEB1814Z	BEB1814ZU		
18"	16"	BEB1816ZB	BEB1816Z	BEB1816ZU		
20"	14"	BEB2014ZB	BEB2014Z	BEB2014ZU		
20"	16"	BEB2016ZB	BEB2016Z	BEB2016ZU		
20"	18"	BEB2018ZB	BEB2018Z	BEB2018ZU		
22"	14"	BEB2214ZB	BEB2214Z	BEB2214ZU		
22"	16"	BEB2216ZB	BEB2216Z	BEB2216ZU		
22"	18"	BEB2218ZB	BEB2218Z	BEB2218ZU		
22"	20"	BEB2220ZB	BEB2220Z	BEB2220ZU		
24"	14"	BEB2414ZB	BEB2414Z	BEB2414ZU		
24"	16"	BEB2416ZB	BEB2416Z	BEB2416ZU		
24"	18"	BEB2418ZB	BEB2418Z	BEB2418ZU		
Floor Toms						
14"	12"	BEF1412B	BEF1412	BEF1412U		
14"	14"	BEF1414B	BEF1414	BEF1414U		
16"	14"	BEF1614B	BEF1614	BEF1614U		
16"	16"	BEF1616B	BEF1616	BEF1616U		
18"	16"	BEF1816B	BEF1816	BEF1816U		
Tom Toms						
8"	6"	BET0806B	BET0806	BET0806U		
8"	7"	BET0807B	BET0807	BET0807U		
8"	8"	BET0808B	BET0808	BET0808U		
10"	6.5"	BET1065B	BET1065	BET1065U		
10"	7"	BET1007B	BET1007	BET1007U		
10"	8"	BET1008B	BET1008	BET1008U		
10"	9"	BET1009B	BET1009	BET1009U		
12"	7"	BET1207B	BET1207	BET1207U		
12"	8"	BET1208B	BET1208	BET1208U		
12"	9"	BET1209B	BET1209	BET1209U		
12"	10"	BET1210B	BET1210	BET1210U		
13"	7.5"	BET1375B	BET1375	BET1375U		
13"	9"	BET1309B	BET1309	BET1309U		
13"	10"	BET1310B	BET1310	BET1310U		
13"	11"	BET1311B	BET1311	BET1311U		
14"	10"	BET1410B	BET1410	BET1410U		
14"	11"	BET1411B	BET1411	BET1411U		
14"	12"	BET1412B	BET1412	BET1412U		
16"	13"	BET1613B	BET1613	BET1613U		
16"	14"	BET1614B	BET1614	BET1614U		
Snare Drums						
13"	6"	BES136B	BES136	BES136U		
14"	5.5"	BES1455B	BES1455	BES1455U		
14"	6.5"	BES1465B	BES1465	BES1465U		
14"	8"	BES148B	BES148	BES148U		

FINISHES (Lacquer)



Crimson Tigerwood Fade
TCGF



Midnight Tigerwood Fade
TMGF



Jungle Quilted Bubinga Burst
QJQB



Garnet Quilted Bubinga Burst
QGQB

STARCLASSIC BUBINGA

Lacquer Finishes



COLOR Flat Deep Green Metallic
w/ smoked black nickel hardware **FDG**

BG52ZUS basic kit

including:
18"x22" bass drum
8"x10" tom tom
9"x12" tom tom
12"x14" floor tom
14"x16" floor tom

[add-on]
6.5"x14" snare drum

KIT CONFIGURATIONS LIST

[3pc Shell Kit]

BG32RZS w/Chrome Hardware
BG32RZBNS w/ Black Nickel Hardware
BG32RZUS w/ Smoked Black Nickel Hardware

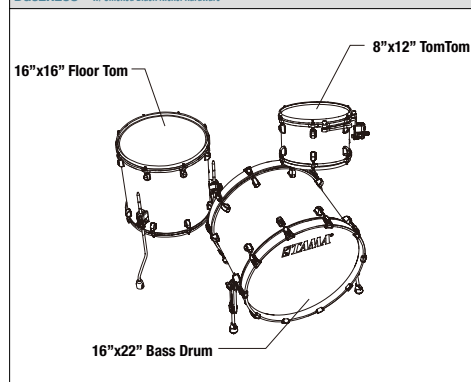

[4pc Shell Kit]

BG42ZS w/Chrome Hardware
BG42ZBNS w/ Black Nickel Hardware
BG42ZUS w/ Smoked Black Nickel Hardware

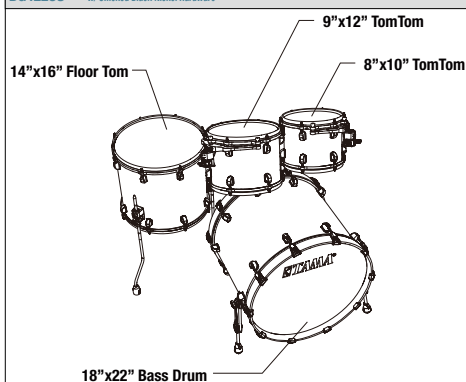

[5pc Shell Kit]

BG52ZS w/Chrome Hardware
BG52ZBNS w/ Black Nickel Hardware
BG52ZUS w/ Smoked Black Nickel Hardware

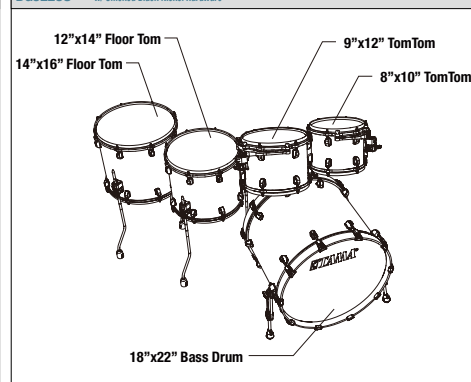

INDIVIDUAL MODEL NUMBERS

Diameter	Depth	Model No.				
		Black Nickel	Chrome	Smoked Black Nickel		
Bass Drums *To order Bass Drum w/ Tom Holder Base, please substitute "Z" with "M". Ex BGB2218Z → BGB2218M						
18"	14"	BGB1814ZBN	BGB1814Z	BGB1814ZU		
18"	16"	BGB1816ZBN	BGB1816Z	BGB1816ZU		
20"	14"	BGB2014ZBN	BGB2014Z	BGB2014ZU		
20"	16"	BGB2016ZBN	BGB2016Z	BGB2016ZU		
20"	18"	BGB2018ZBN	BGB2018Z	BGB2018ZU		
22"	14"	BGB2214ZBN	BGB2214Z	BGB2214ZU		
22"	16"	BGB2216ZBN	BGB2216Z	BGB2216ZU		
22"	18"	BGB2218ZBN	BGB2218Z	BGB2218ZU		
22"	20"	BGB2220ZBN	BGB2220Z	BGB2220ZU		
24"	14"	BGB2414ZBN	BGB2414Z	BGB2414ZU		
24"	16"	BGB2416ZBN	BGB2416Z	BGB2416ZU		
24"	18"	BGB2418ZBN	BGB2418Z	BGB2418ZU		
Floor Toms						
14"	12"	BGF1412BN	BGF1412	BGF1412U		
14"	14"	BGF1414BN	BGF1414	BGF1414U		
16"	14"	BGF1614BN	BGF1614	BGF1614U		
16"	16"	BGF1616BN	BGF1616	BGF1616U		
18"	16"	BGF1816BN	BGF1816	BGF1816U		
Tom Toms						
8"	6"	BGT0806BN	BGT0806	BGT0806U		
8"	7"	BGT0807BN	BGT0807	BGT0807U		
8"	8"	BGT0808BN	BGT0808	BGT0808U		
10"	6.5"	BGT1065BN	BGT1065	BGT1065U		
10"	7"	BGT1007BN	BGT1007	BGT1007U		
10"	8"	BGT1008BN	BGT1008	BGT1008U		
10"	9"	BGT1009BN	BGT1009	BGT1009U		
12"	7"	BGT1207BN	BGT1207	BGT1207U		
12"	8"	BGT1208BN	BGT1208	BGT1208U		
12"	9"	BGT1209BN	BGT1209	BGT1209U		
12"	10"	BGT1210BN	BGT1210	BGT1210U		
13"	7.5"	BGT1375BN	BGT1375	BGT1375U		
13"	9"	BGT1309BN	BGT1309	BGT1309U		
13"	10"	BGT1310BN	BGT1310	BGT1310U		
13"	11"	BGT1311BN	BGT1311	BGT1311U		
14"	10"	BGT1410BN	BGT1410	BGT1410U		
14"	11"	BGT1411BN	BGT1411	BGT1411U		
14"	12"	BGT1412BN	BGT1412	BGT1412U		
16"	13"	BGT1613BN	BGT1613	BGT1613U		
16"	14"	BGT1614BN	BGT1614	BGT1614U		
Snare Drums						
13"	6"	BGS136BN	BGS136	BGS136U		
14"	5.5"	BGS1455BN	BGS1455	BGS1455U		
14"	6.5"	BGS1465BN	BGS1465	BGS1465U		
14"	8"	BGS148BN	BGS148	BGS148U		

FINISHES (Lacquer)

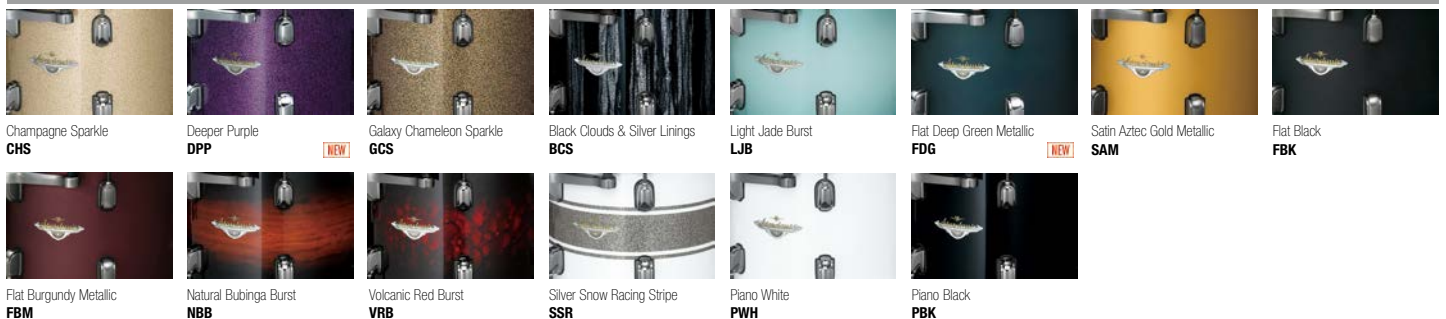

STARCLASSIC MAPLE

Exotic Finishes

In the '80s TAMA's Superstars and Imperialstars reigned supreme - the perfect drums for the times. But TAMA's builders and designers wanted something that transcended trends, something timeless - drums that understood a player's passion and allowed the expression of every genre, style, mood, and technique. They created Starclassic Maple drums...and ignited the thin-shell revolution. And now the new Exotic Finish line offers beautiful, one-of-a-kind exotic wood exteriors for that extra luxurious touch. Numerous options are available to meet the varied and critical needs of professional drummers including a selection of more than 30 different shell sizes. Starclassic Maple also features three shell hardware finishes to choose from: Black Nickel, Chrome and Smoked Black Nickel. Starclassic Maple is simply an unprecedented combination of sight and sound.



COLOR Ruby Pacific Walnut Burst **LRWB**
w/ smoked black nickel hardware

ME42TZUS basic kit

including:
16"x22" bass drum
7"x10" tom tom
8"x12" tom tom
16"x16" floor tom

[add-on]
6.5"x14" snare drum

KIT CONFIGURATIONS LIST

[4pc Shell Kit]

ME42TZS w/Chrome Hardware
ME42TZBS w/Black Nickel Hardware
ME42TZUS w/Smoked Black Nickel Hardware

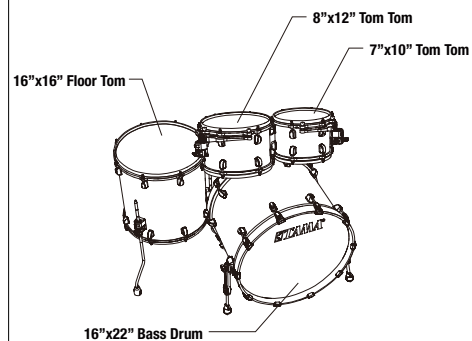

[24"BD 3pc Shell Kit]

ME34CZS w/Chrome Hardware
ME34CZBS w/Black Nickel Hardware
ME34CZUS w/Smoked Black Nickel Hardware

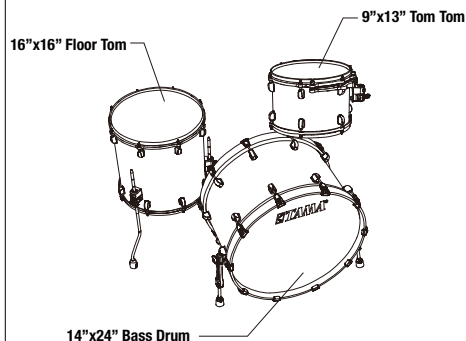

[20"BD 3pc Shell Kit]

ME30CMS w/Chrome Hardware
ME30CMBS w/Black Nickel Hardware
ME30CMUS w/Smoked Black Nickel Hardware

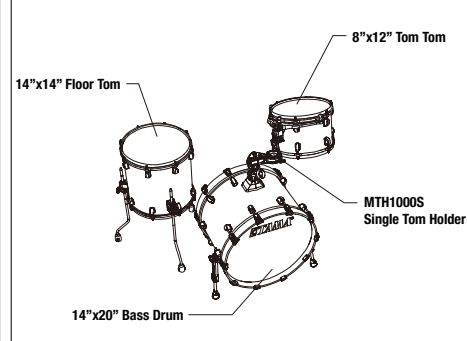

INDIVIDUAL MODEL NUMBERS

Diameter	Depth	Model No.				
		Black Nickel	Chrome	Smoked Black Nickel		
Bass Drums *To order Bass Drum w/ Tom Holder Base, please substitute "Z" with "M". Ex MEB2218Z → MEB2218M						
18"	14"	MEB1814ZB	MEB1814Z	MEB1814ZU		
18"	16"	MEB1816ZB	MEB1816Z	MEB1816ZU		
20"	14"	MEB2014ZB	MEB2014Z	MEB2014ZU		
20"	16"	MEB2016ZB	MEB2016Z	MEB2016ZU		
20"	18"	MEB2018ZB	MEB2018Z	MEB2018ZU		
22"	14"	MEB2214ZB	MEB2214Z	MEB2214ZU		
22"	16"	MEB2216ZB	MEB2216Z	MEB2216ZU		
22"	18"	MEB2218ZB	MEB2218Z	MEB2218ZU		
22"	20"	MEB2220ZB	MEB2220Z	MEB2220ZU		
24"	14"	MEB2414ZB	MEB2414Z	MEB2414ZU		
24"	16"	MEB2416ZB	MEB2416Z	MEB2416ZU		
24"	18"	MEB2418ZB	MEB2418Z	MEB2418ZU		
Floor Toms						
14"	12"	MEF1412B	MEF1412	MEF1412U		
14"	14"	MEF1414B	MEF1414	MEF1414U		
16"	14"	MEF1614B	MEF1614	MEF1614U		
16"	16"	MEF1616B	MEF1616	MEF1616U		
18"	16"	MEF1816B	MEF1816	MEF1816U		
Tom Toms						
8"	6"	MET0806B	MET0806	MET0806U		
8"	7"	MET0807B	MET0807	MET0807U		
8"	8"	MET0808B	MET0808	MET0808U		
10"	6.5"	MET1065B	MET1065	MET1065U		
10"	7"	MET1007B	MET1007	MET1007U		
10"	8"	MET1008B	MET1008	MET1008U		
10"	9"	MET1009B	MET1009	MET1009U		
12"	7"	MET1207B	MET1207	MET1207U		
12"	8"	MET1208B	MET1208	MET1208U		
12"	9"	MET1209B	MET1209	MET1209U		
12"	10"	MET1210B	MET1210	MET1210U		
13"	7.5"	MET1375B	MET1375	MET1375U		
13"	9"	MET1309B	MET1309	MET1309U		
13"	10"	MET1310B	MET1310	MET1310U		
13"	11"	MET1311B	MET1311	MET1311U		
14"	10"	MET1410B	MET1410	MET1410U		
14"	11"	MET1411B	MET1411	MET1411U		
14"	12"	MET1412B	MET1412	MET1412U		
16"	13"	MET1613B	MET1613	MET1613U		
16"	14"	MET1614B	MET1614	MET1614U		
Snare Drums						
13"	6"	MES136B	MES136	MES136U		
14"	5.5"	MES1455B	MES1455	MES1455U		
14"	6.5"	MES1465B	MES1465	MES1465U		
14"	8"	MES148B	MES148	MES148U		

FINISHES (Lacquer)



Ruby Pacific Walnut Burst
LRWB



Emerald Pacific Walnut Burst
LEWB



Natural Pacific Walnut Burst
LNWB



Figured Caribbean Blue Fade
GFCB



Figured Maple Gloss
GFMG

STARCLASSIC MAPLE

Lacquer Finishes



COLOR Flat Burgundy Metallic
w/ smoked black nickel hardware **FBM**

MA42TZUS basic kit

including:
16"x22" bass drum
7"x10" tom tom
8"x12" tom tom
16"x16" floor tom

[add-on]
6.5"x14" snare drum

KIT CONFIGURATIONS LIST

[4pc Shell Kit]

MA42TZS w/Chrome Hardware
MA42TZBNS w/Black Nickel Hardware
MA42TZUS w/Smoked Black Nickel Hardware

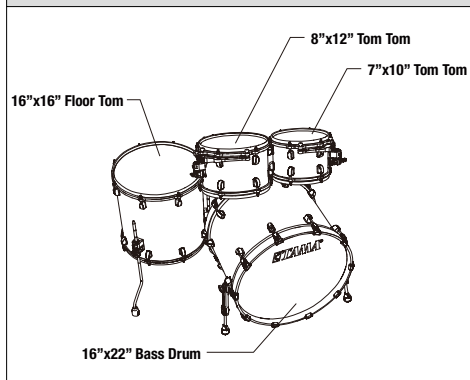

[24"BD 3pc Shell Kit]

MA34CZS w/Chrome Hardware
MA34CZBNS w/Black Nickel Hardware
MA34CZUS w/Smoked Black Nickel Hardware

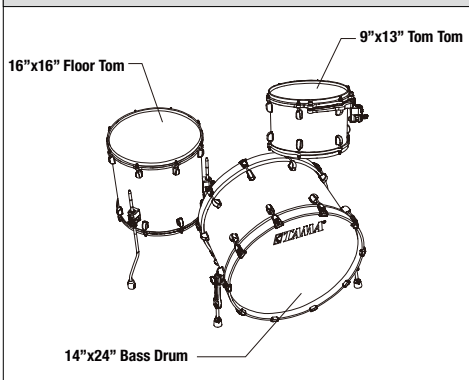

[20"BD 3pc Shell Kit]

MA30CMS w/Chrome Hardware
MA30CMBNS w/Black Nickel Hardware
MA30CMUS w/Smoked Black Nickel Hardware

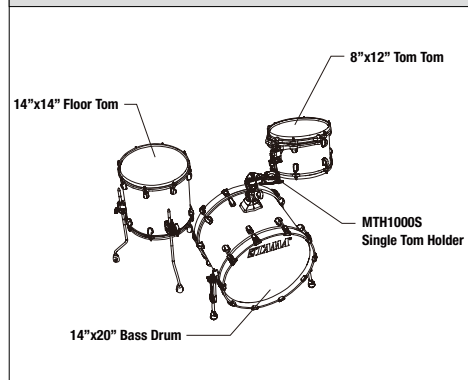

INDIVIDUAL MODEL NUMBERS

Diameter	Depth	Model No.				
		Black Nickel	Chrome	Smoked Black Nickel		
Bass Drums *To order Bass Drum w/ Tom Holder Base, please substitute "Z" with "M". Ex MAB2218Z → MAB2218M						
18"	14"	MAB1814ZBN	MAB1814Z	MAB1814ZU		
18"	16"	MAB1816ZBN	MAB1816Z	MAB1816ZU		
20"	14"	MAB2014ZBN	MAB2014Z	MAB2014ZU		
20"	16"	MAB2016ZBN	MAB2016Z	MAB2016ZU		
20"	18"	MAB2018ZBN	MAB2018Z	MAB2018ZU		
22"	14"	MAB2214ZBN	MAB2214Z	MAB2214ZU		
22"	16"	MAB2216ZBN	MAB2216Z	MAB2216ZU		
22"	18"	MAB2218ZBN	MAB2218Z	MAB2218ZU		
22"	20"	MAB2220ZBN	MAB2220Z	MAB2220ZU		
24"	14"	MAB2414ZBN	MAB2414Z	MAB2414ZU		
24"	16"	MAB2416ZBN	MAB2416Z	MAB2416ZU		
24"	18"	MAB2418ZBN	MAB2418Z	MAB2418ZU		
Floor Toms						
14"	12"	MAF1412BN	MAF1412	MAF1412U		
14"	14"	MAF1414BN	MAF1414	MAF1414U		
16"	14"	MAF1614BN	MAF1614	MAF1614U		
16"	16"	MAF1616BN	MAF1616	MAF1616U		
18"	16"	MAF1816BN	MAF1816	MAF1816U		
Tom Toms						
8"	6"	MAT0806BN	MAT0806	MAT0806U		
8"	7"	MAT0807BN	MAT0807	MAT0807U		
8"	8"	MAT0808BN	MAT0808	MAT0808U		
10"	6.5"	MAT1065BN	MAT1065	MAT1065U		
10"	7"	MAT1007BN	MAT1007	MAT1007U		
10"	8"	MAT1008BN	MAT1008	MAT1008U		
10"	9"	MAT1009BN	MAT1009	MAT1009U		
12"	7"	MAT1207BN	MAT1207	MAT1207U		
12"	8"	MAT1208BN	MAT1208	MAT1208U		
12"	9"	MAT1209BN	MAT1209	MAT1209U		
12"	10"	MAT1210BN	MAT1210	MAT1210U		
13"	7.5"	MAT1375BN	MAT1375	MAT1375U		
13"	9"	MAT1309BN	MAT1309	MAT1309U		
13"	10"	MAT1310BN	MAT1310	MAT1310U		
13"	11"	MAT1311BN	MAT1311	MAT1311U		
14"	10"	MAT1410BN	MAT1410	MAT1410U		
14"	11"	MAT1411BN	MAT1411	MAT1411U		
14"	12"	MAT1412BN	MAT1412	MAT1412U		
16"	13"	MAT1613BN	MAT1613	MAT1613U		
16"	14"	MAT1614BN	MAT1614	MAT1614U		
Snare Drums						
13"	6"	MAS136BN	MAS136	MAS136U		
14"	5.5"	MAS1455BN	MAS1455	MAS1455U		
14"	8"	MAS148BN	MAS148	MAS148U		
14"	6.5"	MAS1465BN	MAS1465	MAS1465U		

FINISHES (Lacquer)

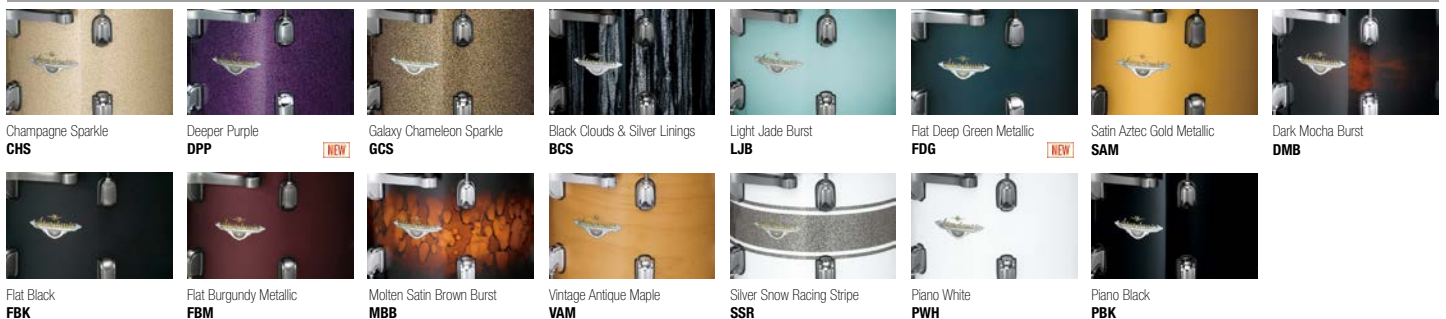

STARCLASSIC PERFORMER B/B

Premium Lacquer Finishes

For more than 30 years, the distinctive, traditional sound of birch has made it the go-to choice for numerous pro drummers. Now, TAMA takes birch in an entirely new direction. Proportionately melding inner plies of bubinga with the classic birch exterior, TAMA has created a blended shell that combines the focused attack of birch, with the enhanced low-end of bubinga—delivering totally a new sound—both dynamic and versatile.



COLOR Coral Red Sparkle **CRD**

PP52LS basic kit

including:
 18"x22" bass drum
 8"x10" tom tom
 9"x12" tom tom
 12"x14" floor tom
 16"x16" floor tom
 MTH1000 double tom holder

[add-on]
 6.5"x14" snare drum

KIT CONFIGURATIONS LIST

[4pc Shell Kit]

PP42S w/Chrome Hardware

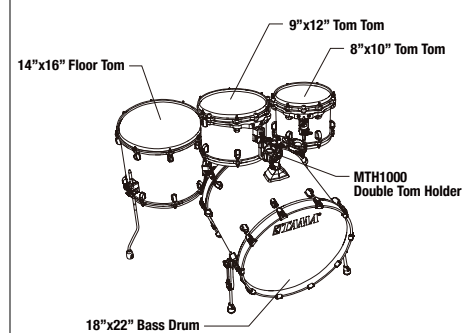

[5pc Shell Kit]

PP52LS w/Chrome Hardware

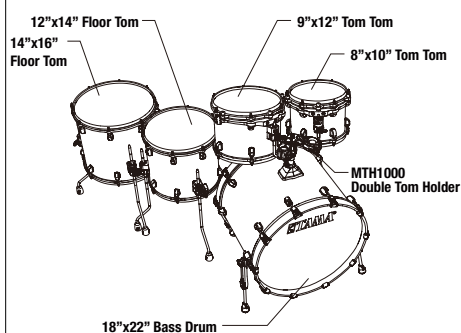

[3pc Shell Kit]

PP32RZS w/Chrome Hardware

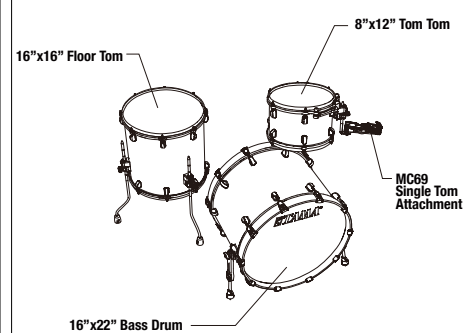

INDIVIDUAL MODEL NUMBERS

Diameter	Depth	Model No.		
Bass Drums				
*To order Bass Drum w/ Tom Holder Base, please substitute "Z" with "M". Ex PBB22DZ → PPB22DM				
20"	16"	PPB20DZ		
20"	18"	PPB20EZ		
22"	16"	PPB22DZ		
22"	18"	PPB22EZ		
22"	20"	PPB22XZ		
24"	16"	PPB24DZ		
24"	18"	PPB24EZ		
Floor Toms				
14"	12"	PPF14A		
14"	14"	PPF14D		
16"	14"	PPF16A		
16"	16"	PPF16D		
18"	16"	PPF18D		
Tom Toms				
8"	6"	PPT8H		
8"	7"	PPT8A		
10"	6.5"	PPT10H		
10"	7"	PPT10R		
10"	8"	PPT10A		
12"	7"	PPT12H		
12"	8"	PPT12R		
12"	9"	PPT12A		
13"	7.5"	PPT13H		
13"	9"	PPT13R		
13"	10"	PPT13A		
14"	11"	PPT14A		
14"	12"	PPT14D		
16"	13"	PPT16A		
16"	14"	PPT16D		
Snare Drums				
13"	6"	PPS136		
14"	5.5"	PPS55		
14"	6.5"	PPS65		

FINISHES (Lacquer)



Gun Metal Classic Stripe
GMS



Coral Red Sparkle
CRD



Blue Nebula Blaze
BNZ

STARCLASSIC PERFORMER B/B

Lacquer Finishes



COLOR Lacquer Oean Blue Ripple **LOR**

PS42S basic kit

including:
 18"x22" bass drum
 8"x10" tom tom
 9"x12" tom tom
 14"x16" floor tom
 MTH1000 double tom holder

[add-on]
 6.5"x14" snare drum

KIT CONFIGURATIONS LIST

[4pc Shell Kit]

PS42S w/Chrome Hardware

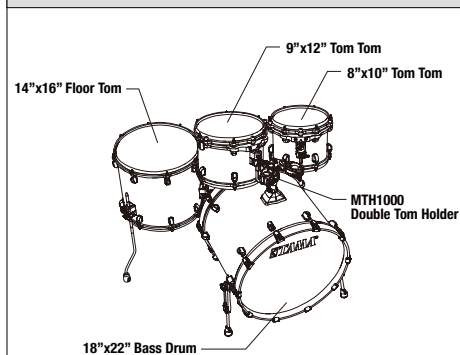

[5pc Shell Kit]

PS52LS w/Chrome Hardware

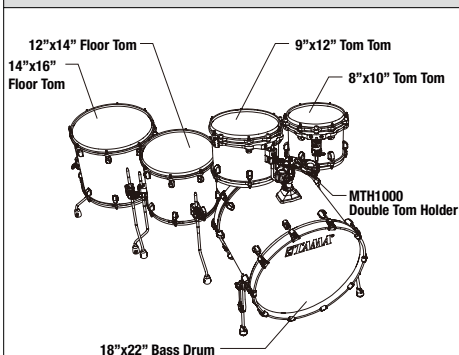

[3pc Shell Kit]

PS32RZS w/Chrome Hardware

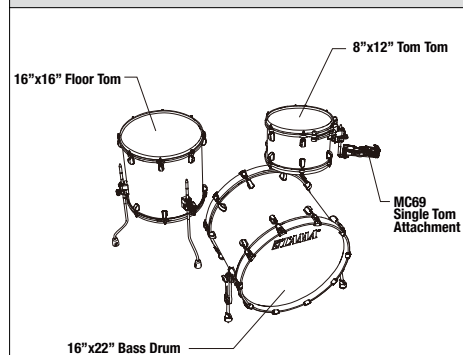

INDIVIDUAL MODEL NUMBERS

Diameter	Depth	Model No.		
Bass Drums *To order Bass Drum w/ Tom Holder Base, please substitute "Z" with "M". Ex PSB22DZ → PSB22DM				
20"	16"	PSB20DZ		
20"	18"	PSB20EZ		
22"	16"	PSB22DZ		
22"	18"	PSB22EZ		
22"	20"	PSB22XZ		
24"	16"	PSB24DZ		
24"	18"	PSB24EZ		
Floor Toms				
14"	12"	PSF14A		
14"	14"	PSF14D		
16"	14"	PSF16A		
16"	16"	PSF16D		
18"	16"	PSF18D		
Tom Toms				
8"	6"	PST8H		
8"	7"	PST8A		
10"	6.5"	PST10H		
10"	7"	PST10R		
10"	8"	PST10A		
12"	7"	PST12H		
12"	8"	PST12R		
12"	9"	PST12A		
13"	7.5"	PST13H		
13"	9"	PST13R		
13"	10"	PST13A		
14"	11"	PST14A		
14"	12"	PST14D		
16"	13"	PST16A		
16"	14"	PST16D		
Snare Drums				
13"	6"	PSS136		
14"	5.5"	PSS55		
14"	6.5"	PSS65		

FINISHES (Lacquer)



Lacquer Ocean Blue Ripple
LOR



Lacquered White Oyster
LWO



Twilight Blue Burst
TWB



Molten Brown Burst
MBR



Cherry Natural Burst
CNT



Smoky Indigo Burst
SIB

STARCLASSIC PERFORMER B/B

Duracover Wrap Finishes



COLOR Ice Blue Pearl **IBP**

PR32RZS basic kit

including:
 16"x22" bass drum
 8"x12" tom tom
 16"x16" floor tom
 MC69 single tom attachment

[add-on]
 6.5"x14" snare drum

KIT CONFIGURATIONS LIST

[4pc Shell Kit]

PR42S w/Chrome Hardware

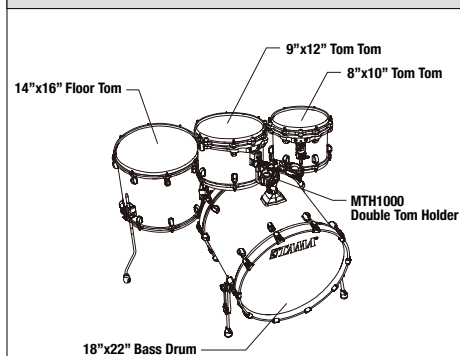

[5pc Shell Kit]

PR52LS w/Chrome Hardware

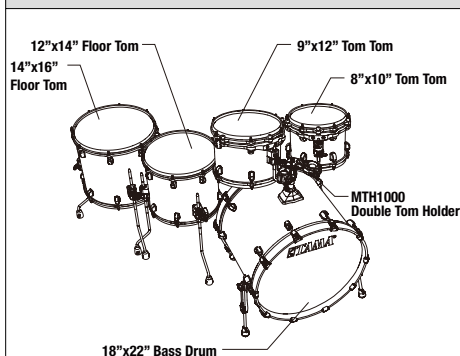

[3pc Shell Kit]

PR32RZS w/Chrome Hardware

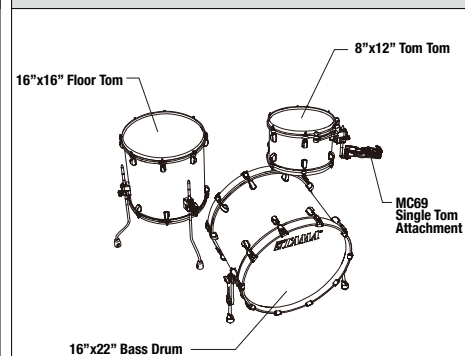

INDIVIDUAL MODEL NUMBERS

Diameter	Depth	Model No.		
Bass Drums *To order Bass Drum w/ Tom Holder Base, please substitute "Z" with "M". Ex PRB22DZ → PRB22DM				
20"	16"	PRB20DZ		
20"	18"	PRB20EZ		
22"	16"	PRB22DZ		
22"	18"	PRB22EZ		
22"	20"	PRB22XZ		
24"	16"	PRB24DZ		
24"	18"	PRB24EZ		
Floor Toms				
14"	12"	PRF14A		
14"	14"	PRF14D		
16"	14"	PRF16A		
16"	16"	PRF16D		
18"	16"	PRF18D		
Tom Toms				
8"	6"	PRT8H		
8"	7"	PRT8A		
10"	6.5"	PRT10H		
10"	7"	PRT10R		
10"	8"	PRT10A		
12"	7"	PRT12H		
12"	8"	PRT12R		
12"	9"	PRT12A		
13"	7.5"	PRT13H		
13"	9"	PRT13R		
13"	10"	PRT13A		
14"	11"	PRT14A		
14"	12"	PRT14D		
16"	13"	PRT16A		
16"	14"	PRT16D		
Snare Drums				
13"	6"	PRS136		
14"	5.5"	PRS55		
14"	6.5"	PRS65		

FINISHES (Duracover Wrap)



Vintage Blue Sparkle
VBL



Ice Blue Pearl
IBP



Vintage Marine Pearl
VMP



Red Oyster
ROY



Charcoal Onyx
CCO

S.L.P. DRUM KITS - STUDIO MAPLE

Lacquer Finish

The Studio Maple kit is designed with 100% Maple shells that are fitted with TAMA's Sound Focus Rings on the shell interior, as well as 100% Maple wood hoops on all shell exteriors. Using Maple extensively throughout the drum set, lets this kit speak with a rich and dense sonic voice, full of warmth and articulation. TAMA's innovative Direct Flexi-Mount system is also incorporated into this kit. This is a two-piece, hinged tom bracket design that controls the amount of saturated sustain and allows for clear tonal separation throughout the toms. While great for performing live, this model really excels in a studio environment, especially in musical settings calling for thick, rich, and warm sounds.



COLOR Gloss Sienna **GSE**

LMP52RTLS basic kit

including:
 16"x22" bass drum
 7"x10" tom tom
 8"x12" tom tom
 14"x14" tom tom
 16"x16" floor tom
 MTH1000 double tom holder

[add-on]
 LMP1465FSEN 6.5"x14" snare drum

KIT CONFIGURATIONS LIST

[4pc Shell Kit]

LMP42RTLS

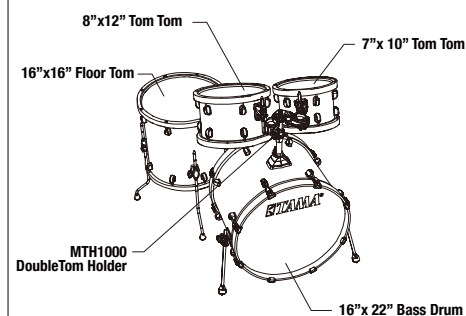

[5pc Shell Kit]

LMP52RTLS

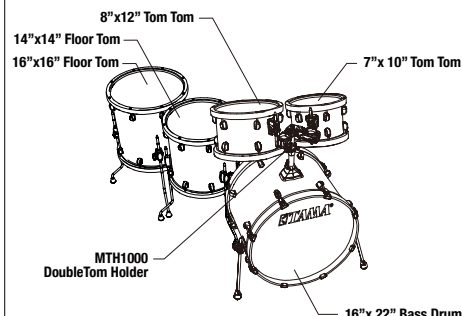

INDIVIDUAL MODEL NUMBERS

Diameter	Depth	Model No.		
Floor Tom				
14"	14"	LMPF14D		

FINISHES (Lacquer)

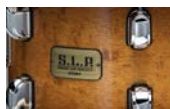

Gloss Sienna

GSE

NEW

S.L.P. DRUM KITS - FAT SPRUCE

Lacquer Finish

The Fat Spruce kit features 100% Spruce shells, which is an uncommon wood for use in drums, but highly regarded for use in instruments like acoustic guitar for its warmth, response, and resonance. The drum community embraced spruce's tonal attributes after TAMA released the S.L.P. Fat Spruce snare drum in 2017. Spruce's sonic profile offers a naturally balanced tone with a very warm and smooth mid-range frequency. The distinctive and swirling Fat Spruce wood grain pattern adds a layer of visual complexity and beauty. TAMA opted to outfit the toms with die-cast hoops, which promotes tonal clarity and a focused attack. This kit is very well-suited for organic music styles, including Indie Rock, R&B, Blues and Jazz.



COLOR Satin Wild Spruce

TWS

LSP30CS basic kit

including:
14"x20" bass drum
8"x12" tom tom
14"x14" tom tom
MTH900BM single tom holder

[add-on]
LSP146WSS 6"x14" snare drum

KIT CONFIGURATIONS LIST

[3pc Shell Kit]

LSP30CS

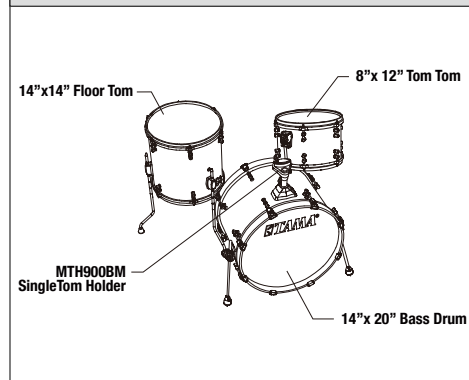

FINISHES (Lacquer)



Satin Wild Spruce
TWS

NEW

S.L.P. DRUM KITS - DYNAMIC KAPUR

Lacquer Finish

The Kapur kit features 100% Kapur shell, which is a relatively new drum shell material. Sonically, Kapur delivers an open, lively and warm sound with outstanding projection. TAMA paired the Kapur with its Sound Arc Hoops to offer plenty of attack with moderately controlled overtones for sonic clarity during intricate tom patterns. Because of its articulate sound and enhanced attack, The Dynamic Kapur kit works very well for funk, fusion and gospel. The high volume dynamic potential also lends itself perfectly to rock genres.



COLOR Gloss Black Kapur Burst **GKP**

LKP52HTS basic kit

including:
 16"x22" bass drum
 6.5"x10" tom tom
 7"x12" tom tom
 12"x14" tom tom
 14"x16" floor tom
 MTH905N double tom holder

[add-on]
 LKP1465KPB 6.5"x14" snare drum

KIT CONFIGURATIONS LIST

[4pc Shell Kit]

LKP42HTS

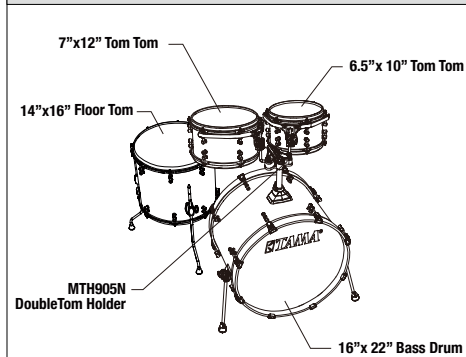

[5pc Shell Kit]

LKP52HTS

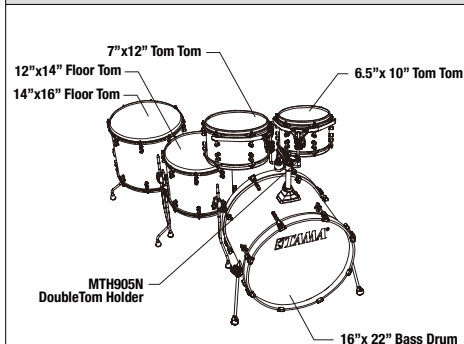

INDIVIDUAL MODEL NUMBERS

Diameter	Depth	Model No.		
Floor Tom				
14"	12"	LKPF14A		

FINISHES (Lacquer)



Gloss Black Kapur Burst
GKP

NEW



SUPERSTAR HYPER-DRIVE DUO

Lacquer Finishes

TAMA's new Superstar Hyper-Drive Duo design gives drummers a new voice to inspire them to explore original and creative rhythmic phrases. The key component of this series is the 10" x 14" snare drum, which TAMA dubs the "Duo Snare." This drum's unique attributes enable it to perform as a conventional floor tom and as an extra-deep sounding snare drum. Mounted on floor tom legs, the 10" deep by 14" diameter drum is fitted with a conventional snare strainer; engaging the strainer and snare wires converts the floor tom into a fully functional snare drum with a deep tonal quality. Drummers can position the drum as a first floor tom, or off to the side of their hi-hat for a more specialized approach. These options allow for new unique phrasing options and a fresh voice within the traditional drum set configuration.



COLOR Satin Silver Vertical Stripe **SSV**

ML52HZBN2 5pc basic kit

including:
 16"x22" bass drum
 6.5"x10" tom tom
 7"x12" tom tom
 14"x16" floor tom
 10"x14" duo snare
 MC69 single tom attachments (x2)

[add-on]
 LST1455H 5.5"x14" snare drum

KIT CONFIGURATIONS LIST

[20"BD 4pc Shell Kit]

ML40HZBN2

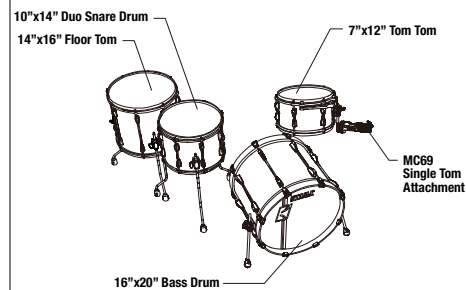

[5pc Shell Kit]

ML52HZBN2

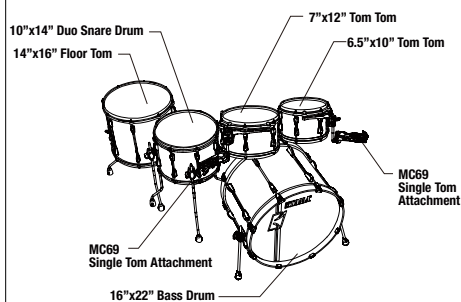

INDIVIDUAL MODEL NUMBERS

Diameter	Depth	Model No.		
Bass Drums				
20"	16"	MLB20DZBN		
22"	16"	MLB22DZBN		
Floor Toms				
14"	12"	MLF14ALBN		
16"	14"	MLF16ALBN		
18"	16"	MLF18DLBN		
Tom Toms				
8"	6"	MLT8HBN		
10"	6.5"	MLT10HBN		
12"	7"	MLT12HBN		
13"	7.5"	MLT13HBN		
14"	8"	MLT14HBN		
Snare Drums				
13"	6"	MLS136BN		
14"	5.5"	MLS55BN		
14"	6.5"	MLS65BN		
Duo Snare Drum				
14"	10"	MLS1410LBN		

FINISHES (Lacquer)



Satin Blue Vertical Stripe
SBV



Satin Silver Vertical Stripe
SSV



Flat Black Vertical Stripe
FBV

NEW

NEW

NEW

SUPERSTAR CLASSIC MAPLE

Lacquer Finishes

For more than forty years, the Superstar name has stood for groundbreaking design, superior build quality, sterling tone, and clear projection. Superstar Classic once again upholds tradition by raising the bar for discerning drummers—and remarkably—does it while also lowering the price. Drawing on Superstar of the past, its classic TAMA T-shape badge and streamlined low-mass single lugs point to the simpler state of art of the 70's, while the ingenious Star-Mount system and new thinner gauge 100% maple shells eclipse anything in its class.



COLOR Dark Indigo Burst **DIB**

CL72S 7pc basic kit

- including:
- 18"x22" bass drum
 - 7"x8" tom tom
 - 8"x10" tom tom
 - 9"x12" tom tom
 - 12"x14" floor tom
 - 14"x16" floor tom
 - 6.5"x14" snare drum
 - MTH600 double tom holder
 - MC69 single tom attachment

KIT CONFIGURATIONS LIST

[5pc Shell Kit]

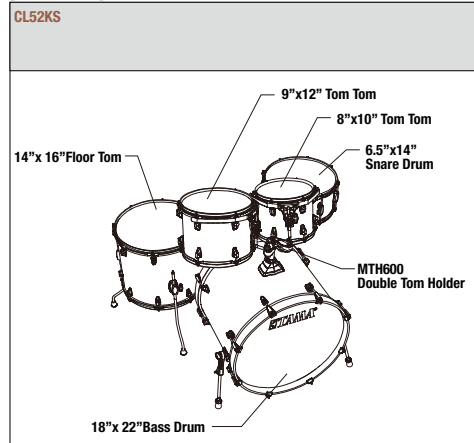

[5pc Shell Kit]

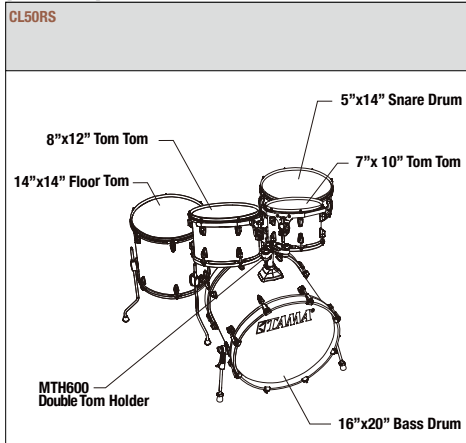

[7pc Shell Kit]

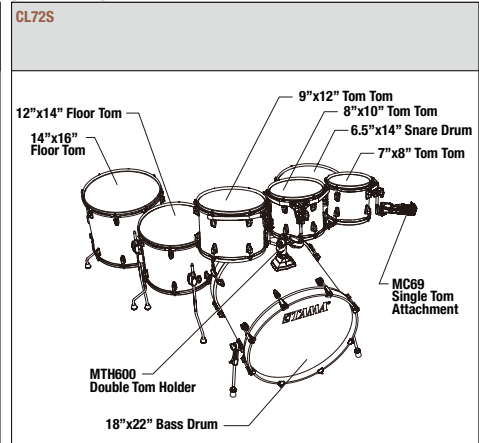

[4pc Shell Kit]

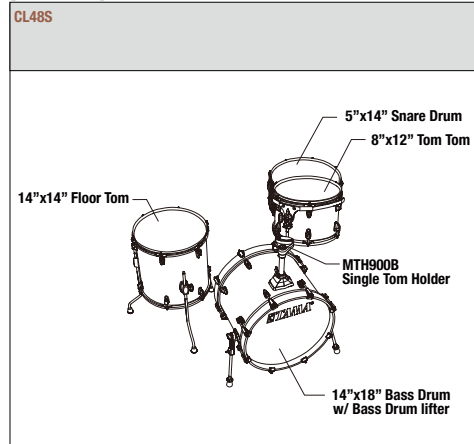

INDIVIDUAL MODEL NUMBERS

Diameter	Depth	Model No.		
Bass Drums				
18" (w/Bass Drum Lifter)	14"	CLB18RL		
20"	16"	CLB20D		
22"	18"	CLB22E		
24"	16"	CLB24D		
Floor Toms				
14"	12"	CLF14A		
14"	14"	CLF14D		
16"	14"	CLF16A		
18"	16"	CLF18D		
Tom Toms				
8"	7"	CLT8A		
10"	7"	CLT10R		
10"	8"	CLT10A		
12"	8"	CLT12R		
12"	9"	CLT12A		
13"	10"	CLT13A		
14"	11"	CLT14A		
Snare Drums				
14"	5"	CLS145		
14"	6.5"	CLS1465		

FINISHES (Lacquer)



Dark Indigo Burst
DIB



NEW

Mahogany Burst
MHB



Classic Cherry Wine
CCW



Transparent Black Burst
TPB



Satin Arctic Pearl
SAP



Tangerine Lacquer Burst
TLB

SUPERSTAR CLASSIC MAPLE

Unicolor Wrap Finishes



COLOR Midnight Gold Sparkle **MGD**

CK52KS 5pc basic kit

including:
 18"x22" bass drum
 8"x10" tom tom
 9"x12" tom tom
 14"x16" floor tom
 6.5"x14" snare drum
 MTH600 double tom holder

KIT CONFIGURATIONS LIST

[5pc Shell Kit]

CK52KS

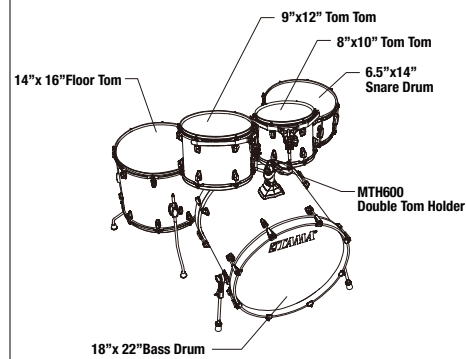

[5pc Shell Kit]

CK50RS

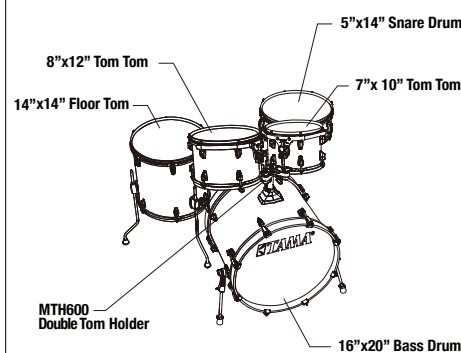

[7pc Shell Kit]

CK72S

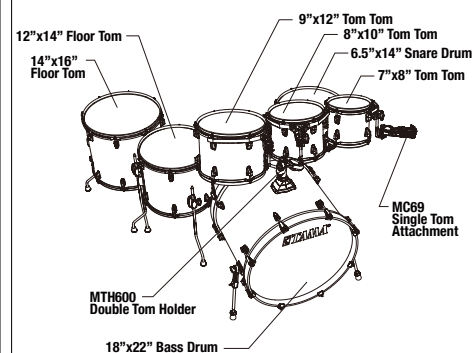

[4pc Shell Kit]

CK48S

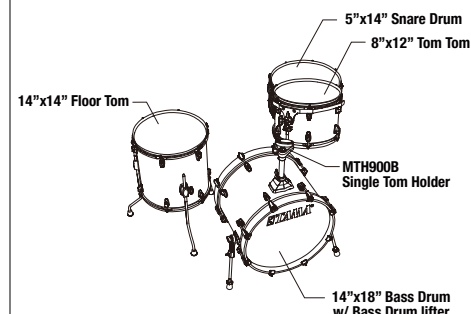

INDIVIDUAL MODEL NUMBERS

Diameter	Depth	Model No.		
Bass Drums				
18" (w/Bass Drum Lifter)	14"	CKB18RL		
20"	16"	CKB20D		
22"	18"	CKB22E		
24"	16"	CKB24D		
Floor Toms				
14"	12"	CKF14A		
14"	14"	CKF14D		
16"	14"	CKF16A		
18"	16"	CKF18D		
Tom Toms				
8"	7"	CKT8A		
10"	7"	CKT10R		
10"	8"	CKT10A		
12"	8"	CKT12R		
12"	9"	CKT12A		
13"	10"	CKT13A		
14"	11"	CKT14A		
Snare Drums				
14"	5"	CKS145		
14"	6.5"	CKS1465		

FINISHES (Unicolor Wrap)



Bright Orange Sparkle
BOS



Midnight Gold Sparkle
MGD



Indigo Sparkle
ISP

IMPERIALSTAR

Unicolor Wrap Finishes with Black Nickel Shell Hardware

With over 40 years of drum building experience, TAMA knows what drummers really want. With this in mind we sought out to design an affordable yet durable kit that retained many high-end features you'll find in our Silverstar, Superstar, and Starclassic lines. What we came up with was Imperialstar. Every aspect of the modern drum kit was exhaustively examined, reexamined, and then improved before it was accepted as part of the Imperialstar design.



COLOR Blacked Out Black
w/ black nickel hardware

BBOB

IP62NBC "READY-TO-ROCK" kit

Drums:
18"x22" bass drum, 8"x10" & 9"x12" tom toms, 12"x14" & 14"x16" floor toms, 5"x14" snare drum.

Hardware:
double tom holder, hi-hat stand, drum pedal, snare stand, boom cymbal stand, straight cymbal stand, drum throne.

IP52NBC "READY-TO-ROCK" kit

Drums:
18"x22" bass drum, 8"x10" & 9"x12" tom toms, 14"x16" floor tom, 5"x14" snare drum.

Hardware:
double tom holder, hi-hat stand, drum pedal, snare stand, boom cymbal stand, straight cymbal stand, drum throne.

[MEINL HCS Cymbals]

Imperialstar all-in-one "READY-TO-ROCK" packages not only have everything you need to rock, you'll rock better with HCS genuine brass cymbals from Meinl®

KIT CONFIGURATIONS LIST

[6pc Complete Kit]

IP62NBC w/ 14"HH+16"C+20"R

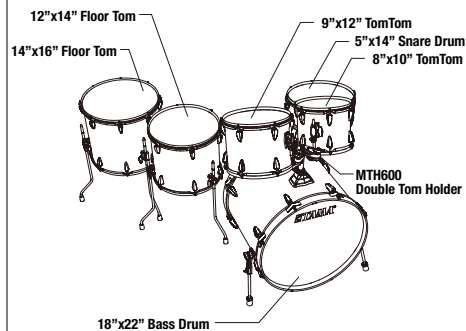

[5pc Complete Kit]

IP52NBC w/ 14"HH+16"C+20"R

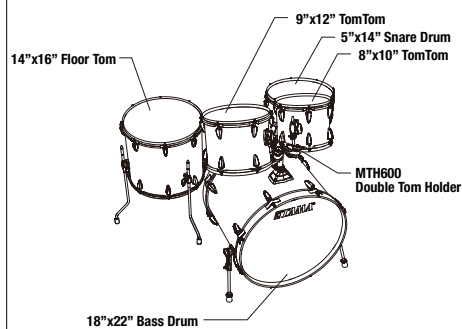

INDIVIDUAL MODEL NUMBERS

Diameter	Depth	Model No.		
Bass Drums				
18" (w/Bass Drum Lifter)	14"	IPB18RLB		
20"	18"	IPB20EB		
22"	18"	IPB22EB		
Floor Toms				
14"	12"	IPF14AB		
14"	14"	IPF14DB		
16"	14"	IPF16AB		
16"	16"	IPF16DB		
18"	16"	IPF18DB		
Tom Toms				
8"	7"	IPT8AB		
10"	8"	IPT10AB		
12"	9"	IPT12AB		
13"	10"	IPT13AB		
Snare Drums				
13"	5"	IPS135B		
14"	5"	IPS145B		
14"	6.5"	IPS1465B		

FINISHES (Unicolor Wrap)



Black Out Black
BOB



Vintage Red
VTR



Sugar White
SGW

NEW

IMPERIALSTAR

Unicolor Wrap Finishes with Chrome Shell Hardware



COLOR Hairline Blue **HLB**

IP62NC "READY-TO-ROCK" kit

Drums: 18"x22" bass drum, 8"x10" & 9"x12" tom toms, 12"x14" & 14"x16" floor toms, 5"x14" snare drum.

Hardware: double tom holder, hi-hat stand, drum pedal, snare stand, boom cymbal stand, straight cymbal stand, drum throne.

IP52NC "READY-TO-ROCK" kit

Drums: 18"x22" bass drum, 8"x10" & 9"x12" tom toms, 14"x16" floor tom, 5"x14" snare drum.

Hardware: double tom holder, hi-hat stand, drum pedal, snare stand, boom cymbal stand, straight cymbal stand, drum throne.

IP50NC "READY-TO-ROCK" kit

Drums: 18"x22" bass drum, 8"x10" & 9"x12" tom toms, 14"x14" floor tom, 5"x14" snare drum.

Hardware: double tom holder, hi-hat stand, drum pedal, snare stand, boom cymbal stand, straight cymbal stand, drum throne.

IP58NC "READY-TO-ROCK" kit

Drums: 14"x18" bass drum w/ bass drum lifter, 8"x10" & 9"x12" tom toms, 12"x14" floor tom, 5"x13" snare drum.

Hardware: double tom holder, hi-hat stand, drum pedal, snare stand, boom cymbal stand, drum throne.

[MEINL HCS Cymbals]

Imperialstar all-in-one "READY-TO-ROCK" packages not only have everything you need to rock, you'll rock better with HCS genuine brass cymbals from Meinl®

KIT CONFIGURATIONS LIST

[6pc Complete Kit]

IP62NC w/ 14"HH+16"C+20"R

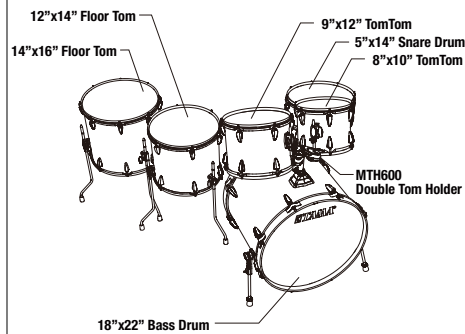

[5pc Complete Kit]

IP52NC w/ 14"HH+16"C+20"R

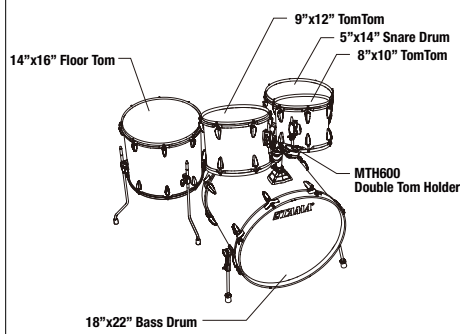

[5pc Complete Kit]

IP50NC w/ 14"HH+16"C+20"R

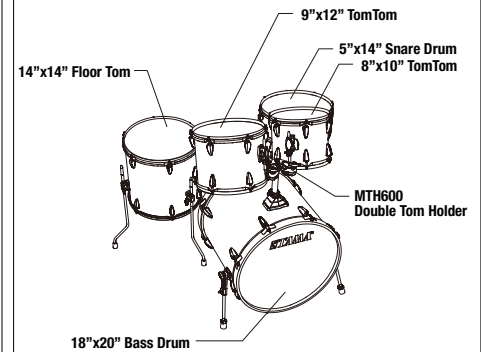

[5pc Complete Kit]

IP58NC w/ 14"HH+18"CR

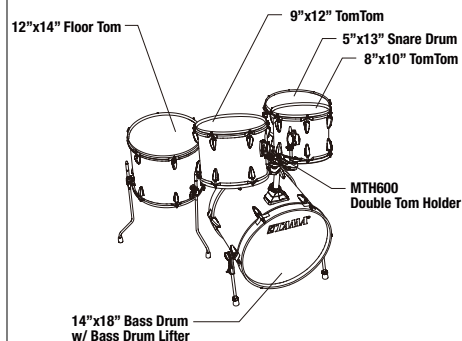

INDIVIDUAL MODEL NUMBERS

Diameter	Depth	Model No.		
Bass Drums				
18" (w/Bass Drum Lifter)	14"	IPB18RL		
20"	18"	IPB20E		
22"	18"	IPB22E		
Floor Toms				
14"	12"	IPF14A		
14"	14"	IPF14D		
16"	14"	IPF16A		
16"	16"	IPF16D		
18"	16"	IPF18D		
Tom Toms				
8"	7"	IPT8A		
10"	8"	IPT10A		
12"	9"	IPT12A		
13"	10"	IPT13A		
Snare Drums				
13"	5"	IPS135		
14"	5"	IPS145		
14"	6.5"	IPS1465		

FINISHES (Unicolor Wrap)



Hairline Black
HBK



Hairline Blue
HLB



Candy Apple Mist
CPM



Midnight Blue
MNB



Champagne Mist
CHM

NEW

CLUB-JAM

Lacquer Finish

We are proud to offer a new compact kit – the "Club-JAM" Kit. This kit adopts some ideas from vintage kits, such as a cymbal holder mounted directly on the bass drum shell and curved bass drum spurs, further setting it apart from the typical compact kit.

Focused yet deep sound from Mersawa / Poplar hybrid shell is just right for small and intimate gigs. Its compact size and configuration make it ideal for working drummers, and it fits comfortably on just about any stage.



COLOR Satin Blonde **SBO**

LJL48S basic kit

Drums:

12"x18" bass drum, 7"x10" tom tom, 7"x14" floor tom, 5"x13" snare drum.

Hardware:

single tom holder, cymbal holder.

KIT CONFIGURATIONS LIST

[4pc Shell Kit]

LJL48S



FINISHES (Lacquer)



Satin Blonde
SBO

NEW

CLUB-JAM

Unicolor Wrap Finishes



COLOR Charcoal Mist **CCM**

LJK48S basic kit

Drums:
12"x18" bass drum, 7"x10" tom tom, 7"x14" floor tom, 5"x13" snare drum.

Hardware:
single tom holder, cymbal holder.

KIT CONFIGURATIONS LIST

[4pc Shell Kit]

LJK48S

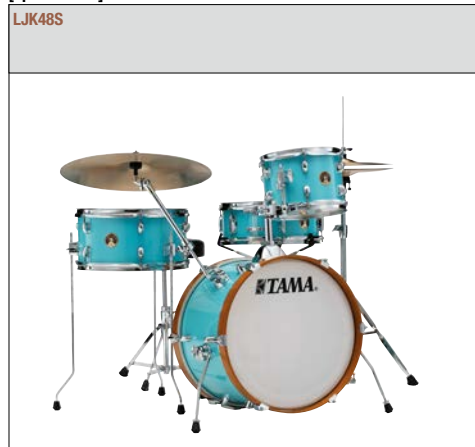

FINISHES (Unicolor Wrap)



Aqua Blue
AQB



Charcoal Mist
CCM

NEW

NEW

COCKTAIL-JAM

Unicolor Wrap Finishes

The Cocktail-JAM Kit™ is a TAMA original in both appearance and sound. It's ideal for hip-hop, jazz, intimate acoustic settings, and tight rehearsal rooms. Completely compact, this kit can easily be set up and played using a throne in spaces much smaller than a typical drum set. Additionally, the Cocktail-JAM Kit and its hardware can be easily packed into just two bags (included with the kit), making it super portable and easy to transport to any gig. Have fun jamming with the Cocktail-JAM Kit!



COLOR Bright Orange Sparkle **BOS**

CJB46 basic kit

Drums:
6"x16" bass drum, 5"x10" tom, 5.5"x14" floor tom, 5"x12" snare drum, Sound Focus Pad, drum bag, hardware bag.

Hardware:
single tom attachments (x2), single pedal.

MCAX5366 clamp kit

Cymbal attachment & hi-hat attachment pack.
(sold separately)

KIT CONFIGURATIONS LIST

[4pc Kit]

CJB46

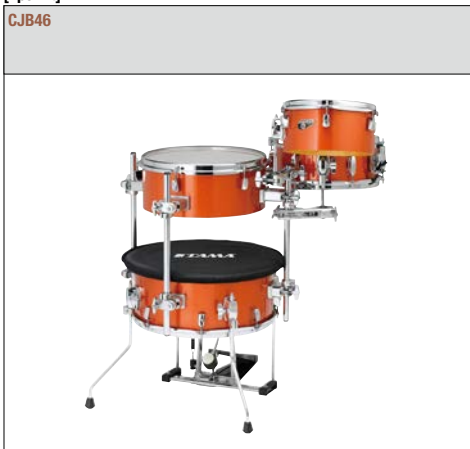

FINISHES (Unicolor Wrap)



Bright Orange Sparkle
BOS



Indigo Sparkle
ISP



Midnight Gold Sparkle
MGD

COCKTAIL-JAM MINI

Unicolor Wrap Finishes



COLOR Candy Apple Mist **CPM**

CJP44 basic kit

Drums:
6"x14" bass drum, 5"x8" tom tom, 5.5"x12" floor tom, 5"x10" snare drum, Sound Focus Pad, drum bag, hardware bag.

Hardware:
single tom attachments (x2), single pedal.
[MCAX5366 clamp kit] cymbal attachment, hi-hat attachment.

MCAX5366 clamp kit

Cymbal attachment & hi-hat attachment pack.
(sold separately)

KIT CONFIGURATIONS LIST

[4pc Kit]

CJP44

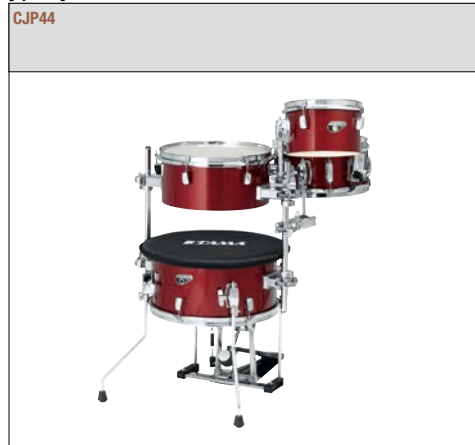

FINISHES (Unicolor Wrap)



Candy Apple Mist
CPM



Hairline Blue
HLB

SNARE DRUMS

TAMA has a wide variety of snare drum options to complement our array of drum kits. From our super high end STAR snare drums to the SOUNDWORKS series, which offers quality at a great price, there is a model to fit every drummer's desired sound and budget.

S.L.P. DUO BIRCH



LBH1410LTPM NEW
 Shell: 7mm, 7ply Birch
 Size: 10"x14"
 Lug: MSL-SCT
 Hoop: Sound Arc Hoop (8 hole)
 Strainer/Butt: MCS70A/MCS70B
 Snare Wire: MS20R14S
 Color: Transparent Mocha (TPM)
 *MTB25E Brackets Equipped, MFLSL3P Legs Included

S.L.P. DYNAMIC KAPUR



LKP1465KPB NEW
 Shell: 5mm, 6ply Kapur
 Size: 6.5"x14"
 Lug: MTL60
 Hoop: Sound Arc Hoop (8 hole)
 Strainer/Butt: MLS50A/MLS50B
 Snare Wire: MS20SN14S
 Color: Black Kapur Burst (KPB)

S.L.P. FAT SPRUCE



LSP146WSS
 Shell: 7mm, 8ply Spruce
 Size: 6"x14"
 Lug: MTL60
 Hoop: Die-Cast Hoop (8 hole)
 Strainer/Butt: MLS50A/MLS50B
 Snare Wire: MS20RL14C
 Color: Wild Satin Spruce (WSS)

S.L.P. VINTAGE POPLAR MAPLE



LMPM1455FNFM
 Shell: 6mm, 2 inner ply Maple + 2 ply Poplar + 1 ply Maple + 1 outer ply Figured Maple w/ Sound Focus Rings
 Size: 5.5"x14"
 Lug: MCHL5S
 Hoop: Steel Mighty Hoop (8 hole)
 Strainer/Butt: MLS50A/MLS50B
 Snare Wire: MS20SN14S
 Color: Natural Figured Maple (NFM)

S.L.P. CLASSIC MAPLE



LMP1455SMP
 Shell: 7mm, 8ply Maple
 Size: 5.5"x14"
 Lug: MTL50
 Hoop: Sound Arc Hoop (10 hole)
 Strainer/Butt: MLS50A/MLS50B
 Snare Wire: MS20RL14C
 Color: Super Maple (SMP)

S.L.P. STUDIO MAPLE



LMP1465FSEN
 Shell: 5mm, 6ply Maple w/ Sound Focus Rings
 Size: 6.5"x14"
 Lug: MSL-SCT
 Hoop: 100% Maple Wood Hoop (8 hole)
 Strainer/Butt: MLS50A/MLS50B
 Snare Wire: MS20SN14S
 Color: Sienna (SEN)

S.L.P. G-MAPLE



LGM137STA
 Shell: 10mm, 11ply Maple + 1 outer ply Tamo Ash
 Size: 7"x13"
 Lug: MTL60
 Hoop: Die-Cast Hoop (8 hole)
 Strainer/Butt: MLS50A/MLS50B
 Snare Wire: MS20SN13C
 Color: Satin Tamo Ash (STA)

S.L.P. G-WALNUT



LGW1465MBW
 Shell: 9mm, 10ply Walnut
 Size: 6.5"x14"
 Lug: MTL60
 Hoop: Sound Arc Hoop (10 hole)
 Strainer/Butt: MLS50A/MLS50B
 Snare Wire: MS30R14S
 Color: Matte Black Walnut (MBW)

S.L.P. G-BUBINGA



LGB146NQB
 Shell: 10mm, 11ply Bubinga + 1 outer ply Quilted Bubinga
 Size: 6"x14"
 Lug: MSL-SCTBN
 Hoop: Steel Mighty Hoop (10 hole)
 Strainer/Butt: MLS50A/MLS50BBN
 Snare Wire: MS20SN14S
 Color: Natural Quilted Bubinga (NOB)

S.L.P. DYNAMIC BRONZE



LBZ1455
 Shell: 1.2mm Bronze
 Size: 5.5"x14"
 Lug: MTL50
 Hoop: Die-Cast Hoop (10 hole)
 Strainer/Butt: MCS70A/MCS70B
 Snare Wire: MS20SN14C

S.L.P. VINTAGE HAMMERED STEEL



LST1455H

Shell: 1.2mm Hammered Steel
Size: 5.5"x14"
Lug: MTL50
Hoop: Sound Arc Hoop (10 hole)
Strainer/Butt: MCS50A/MCS50B
Snare Wire: MS20RL14C

S.L.P. BLACK BRASS



LBR1465

Shell: 1.5mm Steel
Size: 6.5"x14"
Lug: MSL-SCTBN
Hoop: Steel Mighty Hoop (10 hole)
Strainer/Butt: MCS70ABN/MCS70BBN
Snare Wire: MS42R14S

S.L.P. BIG BLACK STEEL



LST148

Shell: 1mm Steel Shell in Matte Black Finish
Size: 8"x14"
Lug: MSL35BN
Hoop: Steel Mighty Hoop (10 hole)
Strainer/Butt: MCS70ABN/MCS70BBN
Snare Wire: MS20SN14S

S.L.P. CLASSIC DRY ALUMINUM



LAL1455

Shell: 1.2mm Seamless Aluminum
Size: 5.5"x14"
Lug: MCHL5S
Hoop: Steel Mighty Hoop (8 hole)
Strainer/Butt: MCS70A/MCS70B
Snare Wire: MS20RL14C

SOUNDWORKS MAPLE



DMP1255MVM

Shell: 5mm, 6ply Maple
Size: 5.5"x12"
Lug: MSL60S
Hoop: Sound Arc Hoop (6 hole, 1.6mm)
Strainer/Butt: MCS70A/MCS70B
Snare Wire: MS20R12S
Color: Matte Vintage Maple (MVM)

SOUNDWORKS MAPLE



DMP1465MVM

Shell: 5mm, 6ply Maple
Size: 6.5"x14"
Lug: MSL60S
Hoop: Sound Arc Hoop (10 hole)
Strainer/Butt: MCS70A/MCS70B
Snare Wire: MS20R14S
Color: Matte Vintage Maple (MVM)

SOUNDWORKS KAPUR



DKP137MRK

Shell: 6mm, 7ply Kapur
Size: 7"x13"
Lug: MSL60S
Hoop: Sound Arc Hoop (8 hole)
Strainer/Butt: MCS70A/MCS70B
Snare Wire: MS20R13S
Color: Matte Brown Kapur (MRK)

SOUNDWORKS KAPUR



DKP146MRK

Shell: 6mm, 7ply Kapur
Size: 6"x14"
Lug: MSL60S
Hoop: Sound Arc Hoop (10 hole)
Strainer/Butt: MCS70A/MCS70B
Snare Wire: MS20R14S
Color: Matte Brown Kapur (MRK)

SOUNDWORKS STEEL



DST1055M

Shell: 1.2mm Steel
Size: 5.5"x10"
Lug: MSL60S
Hoop: Triple Flanged Hoop (6 hole)
Strainer/Butt: MCS70A/MCS70B
Snare Wire: MS16R10S
*Tom bracket & MC69 single tom attachment are included.

SOUNDWORKS STEEL



DST1465

Shell: 1.2mm Steel
Size: 6.5"x10"
Lug: MSL60S
Hoop: Steel Mighty Hoop (10 hole)
Strainer/Butt: MCS70A/MCS70B
Snare Wire: MS20R14S

STARPHONIC MAPLE



PMM146STM

MADE IN JAPAN

Shell: 6mm, 6ply Maple + 1 Mappa Burl outer ply
Size: 6"x14"
Lug: Freedom Lug
Hoop: Grooved Hoop
Strainer/Butt: MLS50A/MLS50B
Snare Wire: MS20RL14C
Color: Satin Mappa Burl (STM)

STARPHONIC BUBINGA



PBC146MNC

MADE IN JAPAN

Shell: 7mm, 8ply Bubinga + 1 Cordia outer ply
Size: 6"x14"
Lug: Freedom Lug
Hoop: Grooved Hoop
Strainer/Butt: MLS50A/MLS50B
Snare Wire: MS20RL14C
Color: Matte Natural Cordia (MNC)

STARPHONIC BRASS



PBR146

MADE IN JAPAN

Shell: 1.2mm Brass
Size: 6"x14"
Lug: Freedom Lug
Hoop: Grooved Hoop
Strainer/Butt: MLS50A/MLS50B
Snare Wire: MS20RL14C

STARPHONIC BELL BRASS



PBB146

MADE IN JAPAN

Shell: 3mm Bell Brass
Size: 6"x14"
Lug: Freedom Lug
Hoop: Grooved Hoop
Strainer/Butt: MLS50A/MLS50B
Snare Wire: MS20RL14C

STARPHONIC ALUMINUM



PAL146

MADE IN JAPAN

Shell: 1.2mm Seamless Aluminum
Size: 6"x14"
Lug: Freedom Lug
Hoop: Grooved Hoop
Strainer/Butt: MLS50A/MLS50B
Snare Wire: MS20RL14C

STARPHONIC STAINLESS STEEL



PSS146

MADE IN JAPAN

Shell: 1mm Stainless Steel w/ R.S.E.
Size: 6"x14"
Lug: Freedom Lug
Hoop: Grooved Hoop
Strainer/Butt: MLS50A/MLS50B
Snare Wire: MS20RL14C

STARPHONIC STEEL



PST146

MADE IN JAPAN

Shell: 1mm Steel
Size: 6"x14"
Lug: Freedom Lug
Hoop: Grooved Hoop
Strainer/Butt: MLS50A/MLS50B
Snare Wire: MS20RL14C

STARPHONIC STEEL



PST137

MADE IN JAPAN

Shell: 1mm Steel
Size: 7"x13"
Lug: Freedom Lug
Hoop: Grooved Hoop
Strainer/Butt: MLS50A/MLS50B
Snare Wire: MS20RL13C

STAR RESERVE SOLID MAPLE



TLM145SOMP

MADE IN JAPAN

Shell: 8mm Solid Maple w/ 8mm Solid Maple
Sound Focus Rings
Size: 5"x14"
Lug: MTL150
Hoop: 2.3mm Brass Sound Arc Hoop (8 hole)
Strainer/Butt: MLS50A / MLS50B
Snare Wire: MS20L14C8
Color: Oiled Natural Maple (OMP)

STAR RESERVE BUBINGA/MAPLE



TMBS158SOCOB

MADE IN JAPAN

Shell: 5.5mm, 8ply Bubinga/Maple (1 inner ply
Cordia+2ply Bubinga+4ply Maple+1 outer ply
Olive Ash)
Size: 8"x15"
Lug: MSL90T
Hoop: Brass Mighty Hoop (8 hole)
Strainer/Butt: MLS50A / MLS50B
Snare Wire: MS20SN15S
Color: Caramel Olive Ash Burst (OCOB)

STAR RESERVE WALNUT/BUBINGA



TBWS1465SGCW

MADE IN JAPAN

Shell: 5.5mm, 7ply Walnut / Bubinga (4ply
Walnut + 2ply Bubinga + 1 outer ply Claro
Walnut) w/ Maple Sound Focus Rings
Size: 6.5"x14"
Lug: MTL160
Hoop: Sound Arc Hoop (10 Hole)
Strainer/Butt: MLS50A / MLS50B
Snare Wire: MS20RL14C
Color: Gloss Claro Walnut (GCW)

STAR RESERVE HAMMERED COPPER



TCS1465H

NEW

MADE IN JAPAN

Shell: 1.5mm Hammered Copper
Size: 6.5"x14"
Lug: MSL90S
Hoop: Customized Brass Mighty Hoop (8 Hole)
Strainer/Butt: MLS50A / MLS50B
Snare Wire: MS20RL14C

STAR SOLID MAPLE



TLM146SOMP

MADE IN JAPAN

Shell: 8mm Solid Maple, w/ 8mm Sound Focus
Rings
Size: 6"x14"
Lug: MSL90S
Hoop: Die-Cast Hoop(8 hole)
Strainer/Butt: MLS50A/MLS50B
Snare Wire: MS20RL14C
Color: Oiled Natural Maple (OMP)
[Inlay Option] Outside Inlay, or w/o Inlay

STAR SOLID ZEBRAWOOD



TLZ146SOZW

MADE IN JAPAN

Shell: 7mm Solid ZebraWood, w/ 7mm Sound
Focus Rings
Size: 6"x14"
Lug: MSL90S
Hoop: Die-Cast Hoop(8 hole)
Strainer/Butt: MLS50A/MLS50B
Snare Wire: MS20RL14C
Color: Oiled Natural ZebraWood (OZW)
[Inlay Option] Outside Inlay, or w/o Inlay

STAR SOLID MAHOGANY



TLH146SOMH MADE IN JAPAN

Shell: 7mm Solid Mahogany w/ 7mm Sound Focus Rings
Size: 6"x14"
Lug: MSL90S
Hoop: Die-Cast Hoop (8 hole)
Strainer/Butt: MLS50A/MLS50B
Snare Wire: MS20RL14C
Color: Oiled Natural Mahogany (OMH) [Inlay Option] Outside Inlay, or w/o Inlay

STAR STAVE WALNUT



TVW146SOWN MADE IN JAPAN

Shell: 10mm, 16pcs Stave Walnut
Size: 6"x14" (TVW146S)
Lug: MSL90S
Hoop: Die-Cast Hoop (8 hole)
Strainer/Butt: MLS50A/MLS50B
Snare Wire: MS20RL14C
Color: Oiled Natural Walnut (OWN) [Inlay Option] Outside Inlay, or w/o Inlay

STAR STAVE ASH



TVA146SOAS MADE IN JAPAN

Shell: 10mm, 16pcs Stave Ash
Size: 6"x14"
Lug: MSL90S
Hoop: Die-Cast Hoop (8 hole)
Strainer/Butt: MLS50A/MLS50B
Snare Wire: MS20RL14C
Color: Oiled Natural Ash (OAS) [Inlay Option] Outside Inlay, or w/o Inlay

BELL BRASS



BB156 MADE IN JAPAN

Shell: 3mm Bell Brass
Size: 6.5"x14"
Lug: 6371N
Hoop: Die-Cast Hoop (10 hole)
Strainer/Butt: MLS50A/MLS50B
Snare Wire: MS20S-S

SIGNATURE PALETTE -KENNY ARONOFF



KA145N MADE IN JAPAN

Trackmaster
Shell: 1mm Brass
Size: 5"x14"
Lug: MSL35
Hoop: Die-Cast Hoop (10 hole)
Strainer/Butt: MUS80A/MUS80B
Snare Wire: MS20SN14S

SIGNATURE PALETTE -KENNY ARONOFF



KA146S MADE IN JAPAN

Trackmaster
Shell: 1mm Brass
Size: 6.5"x14"
Lug: MSL35 (Nickel)
Hoop: Brass Mighty Hoop (10 hole)
Strainer/Butt: MUS80A/MUS80B (Nickel)
Snare Wire: MS20SN14S

SIGNATURE PALETTE -KENNY ARONOFF



KA154 MADE IN JAPAN

Trackmaster Super Piccolo
Shell: 1mm Brass
Size: 4"x15"
Lug: MSL-SCP (Nickel)
Hoop: Brass Mighty Hoop (8 hole)
Strainer/Butt: MCS70A/MUS80B (Nickel)
Snare Wire: MS20SN15S

SIGNATURE PALETTE -CHARLIE BENANTE



CB146S MADE IN JAPAN

Shell: 1.2mm Stainless Steel
Size: 6.5"x14"
Lug: MSL35BN
Hoop: Die-Cast Hoop (10 hole)
Strainer/Butt: MUS80ABN/MUS80BBN
Snare Wire: MS20SN14S

SIGNATURE PALETTE -STEWART COPELAND



SC145 MADE IN JAPAN

Shell: 1.5mm Brass
Size: 5"x14"
Lug: MSL35
Hoop: Die-Cast Hoop (10 hole, Batter side)/Steel Mighty Hoop (10 hole, Snare side)
Strainer/Butt: MUS80A/MUS80B
Snare Wire: MS20SN14S

SIGNATURE PALETTE -JOHN DOLMAYAN



JD146 MADE IN JAPAN

Shell: 5mm, 6ply Maple
Size: 6"x14"
Lug: Specially Designed Tube Lug
Hoop: Die-Cast Hoop (10 hole)
Strainer/Butt: MUS80ABN/MUS80BBN
Snare Wire: MS20SN14C

SIGNATURE PALETTE -PETER ERSKINE



PE106M MADE IN JAPAN

Shell: 10mm, 12pcs Stave Ash
Size: 6"x10"
Lug: MSL90S
Hoop: Die-Cast Hoop (6 Hole)
Strainer/Butt: MLS50A / MLS50B
Snare Wire: MS20SN10S
Super Resonant Mounting System Equipped

SIGNATURE PALETTE -SIMON PHILLIPS



SP125H MADE IN JAPAN

The Pageant
Shell: 6mm, 7ply Figured Maple w/ 6mm Sound Focus Rings
Size: 5"x12"
Lug: MSL35H
Hoop: Die-Cast Hoop (6 hole, Brushed Nickel)
Strainer/Butt: MUS80AH/MUS80BH
Snare Wire: MS20S-12S

SIGNATURE PALETTE -SIMON PHILLIPS



SP1455H

MADE IN JAPAN

The Gladiator
Shell: 1mm Bronze
Size: 5"x14"
Lug: MSL35H
Hoop: Brass Mighty Hoop (10 hole, Brushed Nickel)
Strainer/Butt: MUS80AH/MUS80BH
Snare Wire: MS20S-S

SIGNATURE PALETTE -SIMON PHILLIPS



SP1465H

MADE IN JAPAN

The Monarch
Shell: 6mm, 3ply Figured Maple/3ply Bubinga/2ply Maple w/ 6mm Sound Focus Rings
Size: 6.5"x14"
Lug: MSL-SCTH
Hoop: Customized Brass Mighty Hoop (8 hole)
Strainer/Butt: MUS80AH/MUS80BH
Snare Wire: MS20S-S

SIGNATURE PALETTE -MIKE PORTNOY



MP125ST

MADE IN JAPAN

Shell: 1mm Steel (Hammered Matte Black)
Size: 5"x12"
Lug: MSL-SCT
Hoop: Die-Cast Hoop (6 hole)
Strainer/Butt: MCS100A/MCS70B
Snare Wire: MS20SN12S

SIGNATURE PALETTE -MIKE PORTNOY



MP1455ST

MADE IN JAPAN

Shell: 1mm Steel (Hammered Matte Black)
Size: 5.5"x14"
Lug: MSL-SCT
Hoop: Die-Cast Hoop (8 hole)
Strainer/Butt: MCS100A/MCS70B
Snare Wire: MS20SN14S

SIGNATURE PALETTE -MIKE PORTNOY



MP1455BU

MADE IN JAPAN

Shell: 8mm, 9ply Bubinga
Size: 5.5"x14"
Lug: MSL-SCT
Hoop: Die-Cast Hoop (8 hole)
Strainer/Butt: MCS100A/MCS70B
Snare Wire: MS20SN14S

SIGNATURE PALETTE -JOHN TEMPESTA



JT147

MADE IN JAPAN

Shell: 2mm Brass
Size: 7"x14"
Lug: MSL-SCTBN
Hoop: Die-Cast Hoop (10 hole)
Strainer/Butt: MUS80ABN/MUS80BBN
Snare Wire: MS42R14S

SIGNATURE PALETTE -LARS ULRICH



LU1465

MADE IN JAPAN

Shell: 3mm Diamond Plate Steel
Size: 6.5"x14"
Lug: MSL36
Hoop: Die-Cast Hoop (10 hole)
Strainer/Butt: MUS80A/MUS80B
Snare Wire: MS20SN14S

DRUM PEDALS

Our Iron Cobra pedals have long been praised for being smooth, reliable, and independently adjustable. Iron Cobra pedals are offered in the high end 900 series as well as the standard 600 and 200 models. Speed Cobra 910 and 310 drum pedals feature a longer footboard for a lighter, quicker feel. Our drum pedal range is designed to fit the needs of every drummer.

SPEED COBRA 910 SINGLE PEDAL



HP910LN

- Long Footboard
- Recessed Setting
- Rolling Glide LiteSprocket Cam
- Accu-Strike Cobra Beater
- Swivel Spring Tight
- Super Stabilizer Design
- Para-Clamp II Pro
- Super Spring
- Cobra Coil
- Oiles® Bearing Hinge
- Hinge Guard Block
- Speedo-Ring
- Vari-Pitch Beater Holder
- Hardshell Carrying Case

SPEED COBRA 910 TWIN PEDAL



HP910LWN

- Long Footboard
- Recessed Setting
- Rolling Glide LiteSprocket Cam
- Accu-Strike Cobra Beater
- Swivel Spring Tight
- Super Stabilizer Design
- Para-Clamp II Pro
- Super Spring
- Cobra Coil
- Oiles® Bearing Hinge
- Hinge Guard Block
- Speedo-Ring
- Vari-Pitch Beater Holder
- Hardshell Carrying Case

SPEED COBRA 910 TWIN PEDAL



HP910LWLN

- Left-Footed
- Long Footboard
- Recessed Setting
- Rolling Glide LiteSprocket Cam
- Accu-Strike Cobra Beater
- Swivel Spring Tight
- Super Stabilizer Design
- Para-Clamp II Pro
- Super Spring
- Cobra Coil
- Oiles® Bearing Hinge
- Hinge Guard Block
- Speedo-Ring
- Vari-Pitch Beater Holder
- Hardshell Carrying Case

IRON COBRA 900 SINGLE PEDAL -POWER GLIDE-



HP900PN

- Power Glide LiteSprocket Cam
- Power-Strike Cobra Beater
- Swivel Spring Tight
- Super Stabilizer Design
- Para-Clamp II Pro
- Cobra Coil
- Oiles® Bearing Hinge
- Hinge Guard Block
- Speedo-Ring
- Vari-Pitch Beater Holder
- Hardshell Carrying Case

IRON COBRA 900 TWIN PEDAL -POWER GLIDE-



HP900PWN

- Power Glide LiteSprocket Cam
- Power-Strike Cobra Beater
- Swivel Spring Tight
- Super Stabilizer Design
- Para-Clamp II Pro
- Cobra Coil
- Oiles® Bearing Hinge
- Hinge Guard Block
- Speedo-Ring
- Vari-Pitch Beater Holder
- Hardshell Carrying Case

IRON COBRA 900 TWIN PEDAL -POWER GLIDE-



HP900PWLN

- Left-Footed
- Power Glide LiteSprocket Cam
- Power-Strike Cobra Beater
- Swivel Spring Tight
- Super Stabilizer Design
- Para-Clamp II Pro
- Cobra Coil
- Oiles® Bearing Hinge
- Hinge Guard Block
- Speedo-Ring
- Vari-Pitch Beater Holder
- Hardshell Carrying Case

IRON COBRA 900 SINGLE PEDAL -ROLLING GLIDE-



HP900RN

- Rolling Glide LiteSprocket Cam
- Power-Strike Cobra Beater
- Swivel Spring Tight
- Super Stabilizer Design
- Para-Clamp II Pro
- Cobra Coil
- Oiles® Bearing Hinge
- Hinge Guard Block
- Speedo-Ring
- Vari-Pitch Beater Holder
- Hardshell Carrying Case

IRON COBRA 900 TWIN PEDAL -ROLLING GLIDE-



HP900RWN

- Rolling Glide LiteSprocket Cam
- Power-Strike Cobra Beater
- Swivel Spring Tight
- Super Stabilizer Design
- Para-Clamp II Pro
- Cobra Coil
- Oiles® Bearing Hinge
- Hinge Guard Block
- Speedo-Ring
- Vari-Pitch Beater Holder
- Hardshell Carrying Case

IRON COBRA 600 SINGLE PEDAL -DUO GLIDE-



HP600D

- Duo Glide
- *offered under license from Pearl, U.S.PAT. NO.6172291
- Double Chain Drive
- Speedo-Ring
- Para-Clamp
- Spring Tension Adjustment
- Beater Angle Adjustment
- Dual Sided Beater

IRON COBRA 600 TWIN PEDAL -DUO GLIDE-



HP600DTW

- Duo Glide
- *offered under license from Pearl, U.S.PAT. NO.6172291
- Double Chain Drive
- Speedo-Ring
- Para-Clamp
- Spring Tension Adjustment
- Beater Angle Adjustment
- Dual Sided Beater

SPEED COBRA 310 SINGLE PEDAL



HP310L

- Long Footboard
- Recessed Setting
- Rolling Glide LiteSprocket
- Double Chain Drive
- Spring Tension Adjustment
- Beater Angle Adjustment
- Dual Sided Beater

SPEED COBRA 310 TWIN PEDAL



HP310LW

- Long Footboard
- Recessed Setting
- Rolling Glide LiteSprocket
- Double Chain Drive
- Spring Tension Adjustment
- Beater Angle Adjustment
- Dual Sided Beater

IRON COBRA 200 SINGLE PEDAL



HP200P

- Power Glide
- Spring Tension Adjustment
- Beater Angle Adjustment
- Dual Sided Beater

IRON COBRA 200 TWIN PEDAL



HP200PTW

- Power Glide
- Spring Tension Adjustment
- Beater Angle Adjustment
- Dual Sided Beater

STANDARD SINGLE PEDAL



HP30

- Power Glide
- Spring Tension Adjustment
- Beater Angle Adjustment
- Dual Sided Beater

THE CLASSIC PEDAL



HP50

- Center Strike Height Adjust
- Easy Access Spring Adjustment
- The Classic Beater
- Smooth Surface Footboard
- Individual Adjustment of Beater & Footboard Angle
- Easy-Tight Hoop Clamp
- Compact Folding Design

COBRA CLUTH



HH905XP

A hi-hat control solution for double bass players! Instead of the loose, inexact, drop-clutch approach, the Cobra Clutch delivers a precise, fine-tuned degree of cymbal closure pressure, that's easily engaged and disengaged with a simple tap of the foot.

*The Cobra Clutch comes standard with a form-fitted hardshell carrying case.

TWIN PEDAL ATTACHMENT

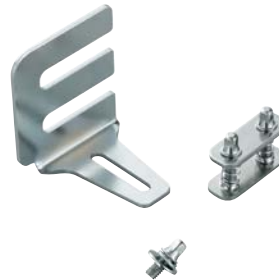

TPA90

Specially designed attachment to connect Speed Cobra 910 and Iron Cobra 900 series pedals with Speed Cobra 910 and Iron Cobra 900 series Hi-hat stands.

HI-HAT STANDS

In addition to bass drum pedals, we offer various hi-hat stands including our high end Iron Cobra & Speed Cobra models as well as our standard Stage Master models.

SPEED COBRA 910 HI-HAT STAND



HH915D

- Spring Seat
- Quick-Set Hi-Hat Clutch
- 6-way Tension Adjustment
- Oiles® Bearing Hinge
- Spare-The-Rods Tension Rod Protector
- Non-Loosening Tension Rod
- Glide-Tite Grip Joint
- Bigger Rubber Feet w/Duo-Spike
- Weight: 5.2kg (11.5lbs)
- 745mm-960mm (29 3/8" - 37 3/4") (Standard Rod)
- / 745mm-810mm (29 3/8" - 31 7/8") (Short Rod)

IRON COBRA 900 HI-HAT STAND -LEVER GLIDE



HH905D

- Spring Seat
- Quick-Set Hi-Hat Clutch
- 6-way Tension Adjustment
- Oiles® Bearing Hinge
- Spare-The-Rods Tension Rod Protector
- Non-Loosening Tension Rod
- Glide-Tite Grip Joint
- Bigger Rubber Feet w/Duo-Spike
- Weight: 5.2kg (11.5lbs)
- Height Adjustment Range:
- 745mm-960mm (29 3/8" - 37 3/4") (Standard Rod)
- / 745mm-810mm (29 3/8" - 31 7/8") (Short Rod)

IRON COBRA 900 HI-HAT STAND -VELO GLIDE



HH805D

- Spring Seat
- Quick-Set Hi-Hat Clutch
- 6-way Tension Adjustment
- Oiles® Bearing Hinge
- Spare-The-Rods Tension Rod Protector
- Non-Loosening Tension Rod
- Glide-Tite Grip Joint
- Bigger Rubber Feet w/Duo-Spike
- Weight: 5.2kg (11.5lbs)
- Height Adjustment Range:
- 745mm-960mm (29 3/8" - 37 3/4") (Standard Rod)
- / 745mm-810mm (29 3/8" - 31 7/8") (Short Rod)

IRON COBRA 900 REMOTE HI-HAT STAND



HH905RH

- JAGWIRE™ Triple-Layered Ultra-Smooth Cable
- Quick-Set Hi-Hat Clutch
- Lever Glide
- 6-way Tension Adjustment
- Oiles® Bearing Hinge
- Exchangeable Cable
- Non-Loosening Tension Rod
- Dual Leg

IRON COBRA 600 HI-HAT STAND



HH605

- Spring Seat
- Swing Lock Clutch
- 6-way Tension Adjustment
- Swivel Foot
- Direct Pull Action
- Spare-The-Rods Tension Rod Protector
- Non-Loosening Tension Rod
- Footboard Angle Adjustment
- Weight: 4.3kg (9.5lbs)
- Height Adjustment Range: 710mm-930mm
- (28" - 36 5/8")

SPEED COBRA 310 HI-HAT STAND



HH315D

- Dual Leg
- 28.6mm Diameter Base Section Tubing
- Security Clutch
- 6-way Tension Adjustment
- Swivel Foot
- Direct Pull Action
- Spare-The-Rods Tension Rod Protector
- Non-Loosening Tension Rod
- Weight: 3.9kg (8.6lbs)
- Height Adjustment Range: 710mm-930mm
- (28" - 36 5/8")

IRON COBRA 200 HI-HAT STAND



HH205

- 5-way Tension Adjustment
- Swivel Foot
- Direct Pull Action
- Non-Loosening Tension Rod
- Toe Guard
- Security Clutch
- Weight: 3.8kg (8.4lbs)
- Height Adjustment Range: 670mm-930mm
- 26 3/8" - 36 5/8")

STAGE MASTER HI-HAT STAND



HH45W

- Direct Pull Action
- Double Braced Legs
- Swivel Foot
- Non-Loosening Tension Rod
- Toe Guard
- Security Clutch
- Weight: 3.5kg (7.8lbs)
- Height Adjustment Range: 670mm-950mm
- (26 3/8" - 36 5/8")

STAGE MASTER HI-HAT STAND



HH45L

- Direct Pull Action
- Single Braced Legs
- Swivel Foot
- Non-Loosening Tension Rod
- Toe Guard
- Security Clutch
- Weight: 3.2kg (7.1lbs)
- Height Adjustment Range: 670mm-950mm (26 3/8" - 36 5/8")

THE CLASSIC HI-HAT STAND



HH55F

NEW

- Single Braced Flat Base Tripod Legs
- Smooth Surface Footboard
- Individual Adjustment of Spring Tension & Footboard Angle
- Knurling on Base Pipe
- Die-Cast Pipe Joint / Memory Lock
- Easy Store Radius Rod
- Weight: 2.3kg (5.1lbs)
- Height Adjustment Range 650mm-950mm (26 3/8" - 36 5/8")
- Storage size: 500mm (19 11/16") (upper section) / 600mm (23 5/8") (lower section)

DRUM THRONES

Being comfortable on your drum set is one of the most important aspects of drumming, making the drum throne a vital yet often overlooked piece of equipment. Our ergonomic 1st Chair Drum Thrones have many original TAMA features to guarantee comfort, stability, and quick, easy setup.

1ST CHAIR ROUND RIDER XL DRUM THRONE -CLOTH TOP



HT850BC

- Round Rider XL "Cloth Top" Seat
- 15" Diameter, 130mm (5 1/8") Thick Round Seat
- HYDRAULIX
- Seat Lock
- Oversized Rubber Feet
- Foot Life
- Weight: 6.0kg (13.3lbs)
- Height Adjustment Range: 515mm - 695mm (21 1/4" - 27 3/8")

1ST CHAIR ROUND RIDER XL DRUM THRONE



HT830R

- Round Rider XL Seat
- 15" Diameter, 130mm (5 1/8") Thick Round Seat
- 1st Chair Height Adjustment
- Seat Lock
- Glide-Tite Grip Joint
- Rocklok
- Oversized Rubber Feet
- Foot Life
- Weight: 6.0kg (13.3lbs)
- Height Adjustment Range: 515mm - 670mm (21 1/4" - 26 3/8")

1ST CHAIR ROUND RIDER XL DRUM THRONE



HT830B

- Round Rider XL Seat
- 15" Diameter, 130mm (5 1/8") Thick Round Seat
- 1st Chair Height Adjustment
- Seat Lock
- Glide-Tite Grip Joint
- Rocklok
- Oversized Rubber Feet
- Foot Life
- Weight: 6.0kg (13.3lbs)
- Height Adjustment Range: 515mm - 670mm (21 1/4" - 26 3/8")

1ST CHAIR ERGO-RIDER DRUM THRONE -CLOTH TOP



HT750BC

- Ergo-Rider "Cloth Top" Seat
- HYDRAULIX
- Seat Lock
- Oversized Rubber Feet
- Foot Life
- Weight: 6.1kg (13.5lbs)
- Height Adjustment Range: 505mm - 685mm (19 7/8" - 27")

1ST CHAIR ERGO-RIDER DRUM THRONE



HT730B

- Ergo-Rider Seat
- 1st Chair Height Adjustment
- Seat Lock
- Glide-Tite Grip Joint
- Rocklok
- Oversized Rubber Feet
- Foot Life
- Weight: 6.1kg (13.5lbs)
- Height Adjustment Range: 505mm - 660mm (19 7/8" - 26")

1ST CHAIR ERGO-RIDER DRUM THRONE -QUARTET



HT741B

- Ergo-Rider Seat
- 1st Chair Height Adjustment
- Seat Lock
- Backrest
- Glide-Tite Grip Joint
- Rocklok
- Oversized Rubber Feet
- Foot Life
- Weight: 9.4kg (20.7lbs)
- Height Adjustment Range: 515mm - 665mm (20 1/4" - 26 3/16")

1ST CHAIR GLIDE RIDER DRUM THRONE -CLOTH TOP



HT550BCN

Glide Rider "Cloth Top" Seat
 -HYDRAULIX
 -Seat Lock
 -Glide-Tite Grip Joint
 -Rocklok
 -Oversized Rubber Feet
 -Foot Life
 -Weight: 5.9kg (13lbs)
 -Height Adjustment Range: 470mm - 650mm
 (18 1/2" - 25 5/8")

1ST CHAIR GLIDE RIDER DRUM THRONE -CLOTH TOP



HT530BCN

Glide Rider "Cloth Top" Seat
 -1st Chair Height Adjustment
 -Seat Lock
 -Glide-Tite Grip Joint
 -Rocklok
 -Oversized Rubber Feet
 -Foot Life
 -Weight: 5.9kg (13lbs)
 -Height Adjustment Range: 470mm - 625mm
 (18 1/2" - 24 5/8")

1ST CHAIR ROUND RIDER DRUM THRONE -CLOTH TOP



HT430BC

Round Rider "Cloth Top" Seat
 -14" Diameter, 120mm (4 3/4") Thick Round Seat
 -1st Chair Height Adjustment
 -Seat Link
 -Rocklok
 -Foot Life
 -Weight: 5.3kg (11.7lbs)
 -Height Adjustment Range: 485mm - 655mm
 (19" - 25 3/4")

1ST CHAIR ROUND RIDER DRUM THRONE



HT430B

Round Rider Seat
 -14" Diameter, 120mm (4 3/4") Thick Round Seat
 -1st Chair Height Adjustment
 -Seat Link
 -Rocklok
 -Foot Life
 -Weight: 5.3kg (11.7lbs)
 -Height Adjustment Range: 485mm - 655mm
 (19" - 25 3/4")

ROADPRO DRUM THRONE



HT75WN

-Saddle Type Seat
 -Double Braced Legs
 -Weight: 4.8kg (10.6lbs)
 -Height Adjustment Range: 480-650mm
 (18 7/8"-25 5/8")

STANDARD DRUM THRONE



HT130

-13" Diameter, 90mm (3 1/2") Thick Round Seat
 -Double Braced Legs
 -Weight: 3.4kg (7.5lbs)
 -Height Adjustment Range: 445mm - 620mm
 (17 1/2" - 24 7/16")

SNARE STANDS

Our STAR snare stand has several unique features which provide the ultimate solution for a flexible and stable snare drum setup.
 Our Roadpro stands now have greater stability, in addition to Quick-Set universal tilters.

STAR HARDWARE SNARE STAND



HS100W

For 12" to 15" Diameter Snare Drums
 -28.6mm Diameter Base Section Tubing
 -Cradle-Hold Snare Basket
 -Glide-Tite Grip Joint
 -True-Sound Insulation Mute
 -Oversized Rubber Feet with Retractable Spike
 -Extra Heavy Double Braced Legs
 -Weight: 3.9kg (8.6lbs)
 -Height Adjustment Range: 400mm - 600mm
 (15 3/4" - 23 5/8")

ROADPRO SNARE STAND



HS800W

For 12" to 15" Diameter Snare Drums
 -28.6mm Diameter Base Section Tubing
 -Omni-Ball Tilter
 -Swiveling Basket
 -Glide-Tite Grip Joint
 -Double Braced Legs
 -Weight: 3.4kg (7.5lbs)
 -Height Adjustment Range: 495mm - 665mm
 (19 1/2" - 26 3/8")

ROADPRO SNARE STAND



HS80W

For 12" to 15" Diameter Snare Drums
-28.6mm Diameter Base Section Tubing
-Quick-Set Tilter
-Swiveling Basket
-Glide-Tite Grip Joint
-Double Braced Legs
-Weight: 3.2kg (7.1lbs)
-Height Adjustment Range: 495mm - 640mm
(19 1/2" - 25 3/16")

ROADPRO SNARE STAND



HS80PW

For 10" to 12" Diameter Snare Drums
-28.6mm Diameter Base Section Tubing
-Quick-Set Tilter
-Swiveling Basket
-Glide-Tite Grip Joint
-Double Braced Legs
-Weight: 3.2kg (7.1lbs)
-Height Adjustment Range: 465mm - 610mm
(18 5/16" - 24")

ROADPRO SNARE STAND



HS80LOW

For 12" to 15" Diameter Snare Drums
-28.6mm Diameter Base Section Tubing
-Low Position Setting Basket
-Quick-Set Tilter
-Glide-Tite Grip Joint
-Double Braced Legs
-Weight: 3.3kg (7.3lbs)
-Height Adjustment Range: 385mm - 530mm
(15 3/16" - 20 7/8")

60 SERIES SNARE STAND



HS60W

For 12" to 15" Diameter Snare Drums
-25.4mm Diameter Base Section Tubing
-Quick-Set Tilter
-Swiveling Basket
-Double Braced Legs
-Weight: 2.6kg (5.8lbs)
-Height Adjustment Range: 470mm - 600mm
(18 1/2" - 23 5/8")

STAGE MASTER SNARE STAND



HS40W

For 12" to 15" Diameter Snare Drums
-25.4mm Diameter Base Section Tubing
-Universal Gearless Tilter
-Swiveling Basket
-Double Braced Legs
-Weight: 2.6kg (5.8lbs)
-Height Adjustment Range: 500mm-630mm
(19 11/16" - 24 13/16")

STAGE MASTER SNARE STAND



HS40S

For 12" to 15" Diameter Snare Drums
-25.4mm Diameter Base Section Tubing
-Universal Gearless Tilter
-Swiveling Basket
-Single Braced Legs
-Weight: 2.5kg (5.6lbs)
-Height Adjustment Range: 500mm-630mm
(19 11/16" - 24 13/16")

STAGE MASTER SNARE STAND



HS40LOW

For 12" to 15" Diameter Snare Drums
-25.4mm Diameter Base Section Tubing
-Universal Gearless Tilter
-Swiveling Basket
-Double Braced Legs
-Weight: 2.7kg (6.0lbs)
-Height Adjustment Range: 400mm-530mm
(15 3/4" - 20 7/8")

THE CLASSIC SNARE STAND



HS50S

For 12" to 15" Diameter Snare Drums
-25.4mm Diameter Base Section Tubing
-Single Braced Tripod Legs
-Classic Style Basket
-Double Braced Arms
-Gearless Tilter
-Die-Cast Pipe Joint / Memory Lock
-Weight: 1.7kg (3.8lbs)
-Height Adjustment Range: 390mm-580mm
(15 3/8" - 22 7/8")
-Storage size: 600mm (23 5/8")

NEW

CYMBAL STANDS

The TAMA STAR Hardware cymbal stand is incredibly flexible with several groundbreaking adjustment features.
The Roadpro cymbal stands benefit from greater stability, and include the same great Quick-Set Tilter and Quick-Set Cymbal Mates.

STAR HARDWARE CYMBAL STAND



HC103BW

- 28.6mm Diameter Base Section Tubing
- Orbital Quick-Tite Cymbal Tilter
- Orbital Quick-Tite Boom Tilter
- Glide-Tite Grip Joint
- True-Sound Insulation Mute
- Ring-True Cymbal Felt
- Quick-Set Cymbal Mate
- Oversized Rubber Feet
- Extra Heavy Double Braced Legs
- Boom Arm Length: 450mm (17 3/4")
- Weight: 6.1kg (13.5lbs)
- Height Adjustment Range: 890mm - 2,090mm (35" - 82 1/4")

ROADPRO CYMBAL STAND



HC84BW

- 28.6mm Diameter Base Section Tubing
- Quick-Set Tilter
- Quick-Set Cymbal Mate
- Boom/Straight Convertible Tilter
- Glide-Tite Grip Joint
- Double Braced Legs
- Detachable Counter Weight
- Boom Arm Length (incl. Counter Weight): 688mm (27 3/32")
- Weight (incl. Counter Weight): 6.2kg (13.7lbs)
- Height Adjustment Range: 820mm - 2,200mm (32 1/4" - 86 5/8")

ROADPRO CYMBAL STAND



HC83BW

- 28.6mm Diameter Base Section Tubing
- Quick-Set Tilter
- Quick-Set Cymbal Mate
- Boom/Straight Convertible Tilter
- Glide-Tite Grip Joint
- Double Braced Legs
- Boom Arm Length: 450mm (17 3/4")
- Weight: 5.0kg (11.1lbs)
- Height Adjustment Range: 820mm - 2,100mm (32 1/4" - 82 5/8")

ROADPRO CYMBAL STAND



HC82W

- 28.6mm Diameter Base Section Tubing
- Quick-Set Tilter
- Quick-Set Cymbal Mate
- Glide-Tite Grip Joint
- Double Braced Legs
- Weight: 4.2kg (9.3lbs)
- Height Adjustment Range: 740mm - 1,610mm (29 1/8" - 63 3/8")

ROADPRO LIGHT CYMBAL STAND



HC83BLS

- 25.4mm Diameter Base Section Tubing
- Quick-Set Tilter
- Quick-Set Cymbal Mate
- Boom/Straight Convertible Tilter
- Glide-Tite Grip Joint
- Single Braced Legs
- Boom Arm Length: 400mm (15 3/4")
- Weight: 3.8kg (8.4lbs)
- Height Adjustment Range: 790mm - 1,850mm (31 1/8" - 72 7/8")

ROADPRO LIGHT CYMBAL STAND



HC82LS

- 25.4mm Diameter Base Section Tubing
- Quick-Set Tilter
- Quick-Set Cymbal Mate
- Glide-Tite Grip Joint
- Single Braced Legs
- Weight: 3.1kg (6.9lbs)
- Height Adjustment Range: 710mm - 1,410mm (28" - 55 1/2")

60 SERIES CYMBAL STAND



HC63BW

- 25.4mm Diameter Base Section Tubing
- Quick-Set Tilter
- Boom/Straight Convertible Tilter
- Double Braced Legs
- Boom Arm Length: 400mm (15 3/4")
- Weight: 3.9kg (8.6lbs)
- Height Adjustment Range: 850mm - 2,010mm (33 1/2" - 79 1/8")

STAGE MASTER CYMBAL STAND



HC43BW

- 25.4mm Diameter Base Section Tubing
- Fine Gear Tilter
- Quick-Set Cymbal Mate
- Boom/Straight Convertible Tilter
- Double Braced Legs
- Boom Arm Length: 400mm (15 3/4")
- Weight: 3.4kg (7.5lbs)
- Height Adjustment Range: 760mm - 1,800mm (30" - 70 13/16")

STAGE MASTER CYMBAL STAND



HC43BS

- 25.4mm Diameter Base Section Tubing
- Fine Gear Tilter
- Quick-Set Cymbal Mate
- Boom/Straight Convertible Tilter
- Single Braced Legs
- Boom Arm Length: 400mm (15 3/4")
- Weight: 3.2kg (7.1lbs)
- Height Adjustment Range: 760mm - 1,800mm (30" - 70 13/16")

STAGE MASTER CYMBAL STAND



HC42W

- 25.4mm Diameter Base Section Tubing
- Fine Gear Tilter
- Quick-Set Cymbal Mate
- Double Braced Legs
- Weight: 2.9kg (6.4lbs)
- Height Adjustment Range: 690mm - 1,420mm (27 1/8" - 55 15/16")

STAGE MASTER CYMBAL STAND



HC42S

- 25.4mm Diameter Base Section Tubing
- Fine Gear Tilter
- Quick-Set Cymbal Mate
- Single Braced Legs
- Weight: 2.7kg (6.0lbs)
- Height Adjustment Range: 690mm - 1,420mm (27 1/8" - 55 15/16")

THE CLASSIC CYMBAL STAND



HC52F

- 19.1mm Diameter Base Section Tubing
- Flat Base Leg Design
- 9mm Diameter Solid Upper Portion
- Fine Gear Tilter
- Compact Folding Design (580mm 22 27/32")
- Weight 1.5kg (3.3lbs)
- Height Adjustment Range: 590mm - 1,300mm (23 1/4" - 51 3/16")

TOM STANDS & TOM HOLDERS

TAMA's tom stands and tom holders feature our original Omni-Ball system which allows each tom to be held securely in place. You can position the drum at virtually any angle simply by loosening one T-nut.

STAR HARDWARE COMBINATION STAND



HTC107W

- 28.6mm Diameter Base Section Tubing
- Swivel-Wing Tom Holder
- Orbital Quick-Tite Cymbal Tilter
- Orbital Quick-Tite Boom Tilter
- Glide-Tite Grip Joint
- True-Sound Insulation Mute
- Ring-True Cymbal Felt
- Extra Heavy Double Braced Legs
- Boom Arm Length: 300mm (11 3/4")
- Weight: 7.2kg (15.9lbs)

STAR HARDWARE DOUBLE TOM STAND



HTW109W

- 28.6mm Diameter Base Section Tubing
- Swivel-Wing Tom Holder
- Stilt System
- Glide-Tite Grip Joint
- Extra Heavy Double Braced Legs
- Weight: 6.0kg (13.3lbs)

STAR HARDWARE SINGLE TOM STAND



HTS108W

- For up to 10" Depth Tom Tom
- 28.6mm Diameter Base Section Tubing
- Glide-Tite Grip Joint
- True-Sound Insulation Mute
- Extra Heavy Double Braced Legs
- Oversized Rubber Feet with Retractable Spike
- Weight: 4.3kg (9.5lbs)

ROADRPO COMBINATION STAND



HTC807W

- 28.6mm Diameter Base Section Tubing
- Omni-Ball Tom Angle Adjustment / Movable Tom Positioning
- Quick-Set Tilter
- Quick-Set Cymbal Mate
- Glide-Tite Grip Joint
- Double Braced Legs
- Boom Arm Length: 300mm (11 3/4")
- Weight: 5.4kg (11.9lbs)

ROADPRO COMBINATION STAND



HTC87W

- 28.6mm Diameter Base Section Tubing
- Omni-Ball Tom Angle Adjustment
- Quick-Set Tilter
- Quick-Set Cymbal Mate
- Glide-Tite Grip Joint
- Double Braced Legs
- Boom Arm Length: 300mm (11 3/4")
- Weight: 5.5kg (12.2lbs)

ROADPRO DOUBLE TOM STAND



HTW839W

- 28.6mm Diameter Base Section Tubing
- Omni-Ball Tom Angle Adjustment
- Stilt System
- Glide-Tite Grip Joint
- Double Braced Legs
- Weight: 5.0kg (11.1lbs)

ROADPRO DOUBLE TOM STAND



HTW849W

- 28.6mm Diameter Base Section Tubing
- Omni-Ball Tom Angle Adjustment
- Glide-Tite Grip Joint
- Double Braced Legs
- Low Profile Tetrapod
- Weight: 5.1kg (11.3lbs)

STAGE MASTER DOUBLE TOM STAND



HTW49W

- 25.4mm Diameter Base Section Tubing
- Omni-Ball Tom Angle Adjustment
- Double Braced Legs
- Weight: 3.6kg (8.0lbs)

THE CLASSIC TOM STAND



HTS58F

NEW

- For 10" to 14" Diameter Drums
- 19.1mm Diameter Base Section Tubing
- Flat Base Leg Design
- Classic Style Basket
- Single Braced Basket Arms
- Gearless Tilter
- Die-Cast Pipe Joint / Memory Lock
- Weight: 1.8kg (4.0lbs)
- Height Adjustment Range: 565mm (22 1/4") - 820mm (32 1/4")
- Storage size: 600mm (23 5/8") (upper section) / 410mm (16 1/8") (lower section)

SMAP: \$69.99

DOUBLE TOM HOLDER



MTH1000

- 25.4mm Diameter Bass Section Tubing
- Swivel-Wing Tom Holder

DOUBLE TOM HOLDER



MTH1000BN

- 25.4mm Diameter Bass Section Tubing
- Swivel-Wing Tom Holder

DOUBLE TOM HOLDER



MTH909

- 25.4mm Diameter Bass Section Tubing
- Sliding Tom Adjustment

DOUBLE TOM HOLDER



MTH909BN

- 25.4mm Diameter Bass Section Tubing
- Sliding Tom Adjustment

DOUBLE TOM HOLDER



MTH905N

- 25.4mm Diameter Tubing
- Sliding Tom Adjustment

DOUBLE TOM HOLDER



MTH600

-25.4mm Diameter Tubing

DOUBLE TOM HOLDER



MTH600BN

-25.4mm Diameter Tubing

SINGLE TOM HOLDER



MTH1000S

-25.4mm Diameter Bass Section Tubing
-Swivel-Wing Tom Holder

SINGLE TOM HOLDER



MTH1000SBN

-25.4mm Diameter Bass Section Tubing
-Swivel-Wing Tom Holder

SINGLE TOM HOLDER



MTH900BS

-25.4mm Diameter Bass Section Tubing

SINGLE TOM HOLDER



MTH900B

-25.4mm Diameter Tubing

HARDWARE KITS

We offer various hardware kit packages to complement any drum set.

IRON COBRA 900 HARDWARE KIT



HG5WN

-HS800W Roadpro Snare Stand
-HC83BW Roadpro Boom Cymbal Stands (x2)
-HH905N Iron Cobra Hi-hat Stand
-HP900PN Iron Cobra Power Glide Single Pedal

IRON COBRA 600 HARDWARE KIT



HV5WN

-HS80W Roadpro Snare Stand
-HC83BW Roadpro Boom Cymbal Stands (x2)
-HH605 Iron Cobra Hi-hat Stand
-HP600D Iron Cobra Duo Glide Single Pedal

IRON COBRA 200 HARDWARE KIT



HB5W

- HS60W Snare Stand
- HC63BW Boom Cymbal Stands (x2)
- HH205 Iron Cobra Hi-hat Stand
- HP200P Iron Cobra Single Pedal

STAGE MASTER HARDWARE KIT



MM5WN

- HC43BW Stage Master Boom Cymbal Stands (x2)
- HH45W Stage Master Hi-Hat Stand
- HS40W Stage Master Snare Drum Stand
- HP200P Iron Cobra Single Pedal

STAGE MASTER HARDWARE KIT



MM4SB

NEW

- HC43BS Stage Master Boom Cymbal Stand
- HC42S Stage Master Straight Cymbal Stand
- HH45S Stage Master Hi-Hat Stand
- HS40S Stage Master Snare Drum Stand
- PBH02L Hardware Bag

BOOM STAND 2PC PACK



HC13BW X2

- HC13BW Boom Cymbal Stands (x2)

THE CLASSIC STAND HARDWARE KIT



HC4FB

NEW

- HC52F Straight Cymbal Stands (x2)
- HH55F Hi-Hat Stand
- HS50S Snare Stand
- SBH01 Hardware Bag

POWER TOWER SYSTEM

TAMA's Power Tower System allows you to maintain the same precise set-up time after time. It utilizes 38.1mm stainless round pipes which allow for drums and hardware to be set-up at any angle quickly and easily.

POWER TOWER SYSTEM BASIC UNIT



PMD1100M

- 1100mm Curved Pipe (38.1mm diameter) x 1pc
- 850mm Straight Pipe (38.1mm diameter) w/19.1mm diameter Joint x 2pc
- 40mm x 20mm x 450mm Square Pipe x 2pc
- Leg Joint Bracket x 2pc
- Rubber Foot x 4pc
- Cross Joint Bracket (J30TS) x 2pc
- Multi Holder (J34T) x 2pc
- Memory Lock (A13S) x 4pc

POWER TOWER SYSTEM ADDITIONAL UNIT



PMD1100A

- 1100mm Curved Pipe (38.1mm diameter) x 1pc
- 850mm Straight Pipe (38.1mm diameter) w/19.1mm diameter Joint x 1pc
- 40mm x 20mm x 450mm Square Pipe x 1pc
- Leg Joint Bracket x 1pc
- Rubber Foot x 2pc
- Cross Joint Bracket (J30TS) x 2pc
- Multi Holder (J34T) x 1pc
- Memory Lock (A13S) x 3pc

POWER TOWER SYSTEM ADDITIONAL UNIT



PMD900A

- 900mm Curved Pipe (38.1mm diameter) x 1pc
- 850mm Straight Pipe (38.1mm diameter) w/19.1mm diameter Joint x 1pc
- 40mm x 20mm x 450mm Square Pipe x 1pc
- Leg Joint Bracket x 1pc
- Rubber Foot x 2pc
- Cross Joint Bracket (J30TS) x 2pc
- Multi Holder (J34T) x 1pc
- Memory Lock (A13S) x 3pc

CROSS JOINT BRACKET



J30TS

90 degree perpendicular pipe clamp that allows horizontal and vertical pipes to be set at an equal height.

MULTI HOLDER



J34T

Rack mount for L-rods, tom or cymbal holders. Fits pipes from 10.5mm to 28.6mm in diameter.

MEMORY LOCK



A13S

Memory clamp designed specifically for the Power Tower System.

SINGLE TOM HOLDER



MTH900BS

A single tom holder with 25.4mm diameter base tube.

CLAMPS AND ATTACHMENTS

Back in the 1970's TAMA's original introduction of the multi-clamp was a real revolution in the complex instrument we know as the drum kit. Today, multi-clamps are standard equipment in drums of all brands.

UNIVERSAL CLAMP



MC66

One side can hold pipes with diameters from 15.9mm to 28.6mm, while the other side is a ratchet holder that can hold a rod from 9mm to 12mm in diameter at various angles. An excellent clamp for adding an array of new set-up possibilities.

UNIVERSAL CLAMP



MC67

The heavier duty version of the MC66. One side holds pipes with diameters from 15.9mm to 28.6mm, while the other side is a ratchet holder that can hold a 12mm to 25.4 mm diameter rod or pipe at various angles.

MULTI-CLAMP



MC61

A basic clamp for connecting stands with pipes from 15.9mm to 28.6mm in diameter with any attachment having a 19.1mm diameter pipe.

MULTI-CLAMP



MC62

A double multi-clamp for connecting two pipes from 15.9mm to 28.6mm in diameter. Both sides feature the FastClamp Easy Set-Up System.

COMPACT CLAMP



MC5

A clamp for connecting parts with diameters of between 9mm to 12mm together. By combining a boom arm (MCB30EN, MCB45EN) and an L-rod (LLT, LCB, LCYE), this clamp can be used to attach a variety of parts onto a simple boom arm.

COMPACT CLAMP



MC7

Same function as the MC5, but with even greater flexibility. The ratchet holder section can hold any diameter tube from 12mm to 25.4mm.

HOOP GRIP



MC8

NEW

The Hoop Grip is a simple tool that allows you to add cymbals or other accessories to your drum kit to expand your setup and customize your sound with ease. The possibilities are endless!

-available on Steel hoops and Die-Cast Hoops.
*NOT available on Wood Hoops.
*NOT recommended for Brass hoops.

Z-ROD FOR COWBELL



ZCB

NEW

Z-rod for mounting cowbell or other percussion instruments and accessories (9mm diameter)

Z-ROD FOR SPLASH CYMBAL -LONG



ZCYEL

NEW

Z-rod for mounting lightweight cymbals (10.5mm diameter)

Z-ROD FOR SPLASH CYMBAL -SHORT



ZCYE

NEW

Z-rod for mounting lightweight cymbals (10.5mm diameter)

ACCESSORY MOUNT ARM



HCA20

NEW

Accessory mount arm for mounting cymbals or accessories for snare drum effects (10.5mm diameter base section)

CLOSED HI-HAT



MXA53

Simply designed closed hi-hat attachment that allows for two different settings by turning a lever. Attachable to stands from 15.9mm to 28.6mm in diameter. Great for double bass or double pedal players. And, you can also set up half open hi-hat cymbals by adjusting the spring.

CLOSED HI-HAT



MXA73N

This closed hi-hat attachment is ideal for double bass playing. The tension adjustment knob makes it possible to finely adjust the degree of opening of the hi-hat cymbals. In addition, the angle of the bottom cymbal is also adjustable, which allows for subtle adjustment of the sound of a closed or half-open hi-hat by changing how air escapes with each hit.

Details:

- Quick-set hi-hat clutch
- Quick-set tilter

L-ROD FOR TOM TOM



LLT

L-rod for mounting toms (10.5mm diameter).

L-ROD FOR COWBELL



LCB

L-rod for mounting different hand percussion instruments and accessories. The 9mm diameter rod fits most popular percussion instruments designed for attachment to a 3/8" rod.

L-ROD FOR CYMBAL



LCYE

L-rod for mounting lightweight cymbals.

Details:

- Quick-set cymbal mate

HAT STACK



CSH5

NEW

The "Hat Stack" is the simplest and most compact cymbal stacker in TAMA history. It allows you to attach a small diameter cymbal to your hi-hat rod with just a drum key. Also, its tiny size – 25 mm (1") diameter x 40 mm (1.5") height – doesn't interfere with your setup and is super easy to carry. It is a groundbreaking new item that can expand your sound without having to purchase additional clamps.

- Easily attach a small cymbal to hi-hat rod measuring up to 7mm in diameter
- Compact size and lightweight for easy transport and storage - 25mm (1") diameter x 40mm (1.5") height
- Ability to adjust cymbal sustain

CYMBAL STACKER



CSA15

The CSA15 is a straight-forward cymbal stacker useful for adding small cymbals to your setup using the M8 threaded cymbal rod.

CYMBAL STACKER



CSA25

The CSA25 allows positioning of a small cymbal on the M8 threaded cymbal rod, as well as independent angle adjustment.

RATCHET ARM



MRB30

The MRB30 features a 12mm rod for lighter duty usage.

Details: 300mm (11 3/4") length

RATCHET ARM



MTA30

The MTA30 ratchet arm features a 19.1mm pipe.

Details: 300mm (11 3/4") length

RATCHET ARM



MTA45

The MTA45 ratchet arm features a 19.1mm pipe.

Details: 450mm (17 3/4") length

BOOM ARM



MCB30EN

MCB30EN can be used in combination with a ratchet arm or the MC66 universal clamp is available.

Details:

- 300mm (11 3/4") length
- Quick-set tilter
- Quick-set cymbal mate

BOOM ARM



MCB45EN

MCB45EN can be used in combination with a ratchet arm or the MC66 universal clamp is available.

Details:

- 450mm (17 3/4") length
- Quick-set tilter
- Quick-set cymbal mate

CYMBAL HOLDER



CA30EN

This cymbal holder with a pipe diameter of 19.1mm can be attached to stands using either the MC61 or MC62 multi-clamp.

The CA30EN is a professional-grade model equipped with a conversion function that allows the boom arm to be stored in the stand pipe and also includes the Quick-Set Tilter for convenient and easy set-up.

Details:

- 300mm (11 3/4") length
- Quick-set tilter
- Quick-set cymbal mate

CYMBAL HOLDER



CA45EN

This cymbal holder with a pipe diameter of 19.1mm can be attached to stands using either the MC61 or MC62 multi-clamp.

The CA45EN is a professional-grade model equipped with a conversion function that allows the boom arm to be stored in the stand pipe and also includes the Quick-Set Tilter for convenient and easy set-up.

Details:

- 450mm (17 3/4") length
- Quick-set tilter
- Quick-set cymbal mate

CYMBAL ATTACHMENT



CCA30

The assortment of boom cymbal holder and MC61 multi-clamp. By connecting to stands from 15.9mm to 28.6mm in diameter, you can add any cymbal easily.

CYMBAL ATTACHMENT



MCA53

The MCA53 is a simplified attachment based on the functionality of the MCA63EN. Add cymbals by securing this attachment to stands from 15.9mm to 28.6mm in diameter.

CYMBAL ATTACHMENT



MCA63EN

Combines the MC66 universal clamp and the MCB30EN boom arm. Works perfectly for adding cymbals and accessories to stands with pipes from 15.9mm to 28.6mm in diameter.

Details:

- Quick-set tilter
- Quick-set cymbal mate

CYMBAL ATTACHMENT



CYA5E

Combines the MC5 compact clamp with the LCYE L-rod for mounting one cymbal to one boom arm. Can be clamped to rods from 9mm to 12mm in diameter or to the L-rod of a tom holder.

Details: Quick-set cymbal mate

TOM ATTACHMENT



MC69

Clamping this attachment on a 15.9mm to 28.6mm diameter pipe allows for direct set-up of toms. Even with a compact construction, the inclusion of the Omni-ball feature at the angle adjustment point lets you adjust toms to any angle.

TOM ADAPTER



MTH900AS

This adapter allows you to add single toms to stands using the flexibility and speed of TAMA's Omni-Ball/L-rod combination.

COWBELL ATTACHMENT



CBA5

Compact attachment for mounting hand percussion such as cowbells or tambourines. Combines the MC5 compact clamp and the LCB L-rod to provide set-up flexibility. The 3/8" L-rod fits most popular percussion instruments and accessories.

COWBELL ATTACHMENT



CBA56

Combines the universal clamp with the LCB L-rod to mount most popular percussion instruments and accessories. Can be attached to pipes ranging from 15.9 mm to 28.6 mm in diameter.

COWBELL ATTACHMENT



CBH20

This simple attachment allows cowbells to be mounted on the bass drum. The length and angle of the L-rod can be easily changed for optimum positioning.

HI-HAT ATTACHMENT



MHA623

Connects the hi-hat to the hoop of a double bass drum so the hi-hat legs can be closed. An improved design featuring the Para-Clamp mechanism from the Iron Cobra pedal makes attachment even easier and more secure.

MICROPHONE STANDS

Just as many years ago, TAMA single-handedly altered the essence of the modern drum set through its re-invention of drum hardware—TAMA now turns that same degree of engineering dedication to yet another unevolved category of music gear: the microphone stand.

IRON WORKS STUDIO TELESCOPING BOOM STAND



MS756BK

- Vice-Grip Boom Tilter
- Iron-Core Legs with Vibration-Isolating Rubber Feet
- Iron-Core Telescoping Boom Arm
- Silent T-Handle
- Detachable Boom Arm
- Height: 975-1650mm (38 3/8"-64 15/16")
- Boom arm: 505-850mm (19 7/8"-33 7/16")
- Weight: 5.4kg (11.9lbs)
- Black Finish

IRON WORKS STUDIO ROUND BASE TELESCOPING BOOM STAND



MS756RBK

- Vice-Grip Boom Tilter
- Heavy Round Cast Base
- Iron-Core Telescoping Boom Arm
- Silent T-Handle
- Detachable Boom Arm
- Height: 990mm - 1700mm (39" - 66 13/16")
- Boom arm: 505mm - 850mm (19 7/8" - 33 7/16")
- Weight: 8.2kg (18.1lbs)
- Black Finish

IRON WORKS STUDIO LOW PROFILE TELESCOPING BOOM STAND



MS756LBK

- Vice-Grip Boom Tilter
- Iron-Core Legs with Vibration-Isolating Rubber Feet
- Iron-Core Telescoping Boom Arm
- Silent T-Handle
- Detachable Boom Arm
- Height: 440mm - 605mm (17 5/16" - 23 13/16")
- Boom arm: 505mm - 850mm (19 7/8" - 33 7/16")
- Weight: 4.7kg (10.4lbs)
- Black Finish

IRON WORKS STUDIO ROUND BASE EXTRA LOW PROFILE TELESCOPING BOOM STAND



MS756RELBK

- Vice-Grip Boom Tilter
- Iron-Core Telescoping Boom Arm
- Silent T-Handle
- Detachable Boom Arm
- Heavy Round Cast Base
- Height: 280mm (11 1/32")
- Boom arm: 505mm - 850mm (19 7/8" - 33 7/16")
- Weight: 7.7kg (17.0lbs)
- Black Finish

IRON WORKS STUDIO TRIPOD CAST BASE STRAIGHT STAND



MS750TBK

- Die-cast Locking Thumb Nut
- Sure-Cast Adjustment Collar
- Latch-Lok Sleeve Insert
- Smaller footprint, solid-cast tripod shaped base
- Height: 945mm – 1685mm (37 3/16" – 66 5/16")
- Weight: 3.8kg (8.4lbs)
- Black Finish

IRON WORKS TOUR BOOM STAND



MS455BK

- Cast Grip Boom Tilter
- Die-Cast Locking Thumb Nut
- Sure-Cast Adjustment Collar
- Detachable Boom Arm
- Height: 985mm – 1660mm (38 3/4" – 65 3/8")
- Boom arm: 845mm (33 1/4")
- Weight: 3.5kg (7.8lbs)
- Black Finish

IRON WORKS TOUR TELESCOPING BOOM STAND



MS456BK

- Cast Grip Boom Tilter
- Die-Cast Locking Thumb Nut
- Sure-Cast Adjustment Collar
- Iron-Core Telescoping Boom Arm
- Detachable Boom Arm
- Height: 985mm – 1660mm (38 3/4" – 65 3/8")
- Boom arm: 505mm – 845mm (19 7/8" – 33 1/4")
- Weight: 3.9kg (8.6lbs)
- Black Finish

IRON WORKS TOUR LOW PROFILE TELESCOPING BOOM STAND



MS456LBK

- Cast Grip Boom Tilter
- Die-Cast Locking Thumb Nut
- Sure-Cast Adjustment Collar
- Iron-Core Telescoping Boom Arm
- Detachable Boom Arm
- Height: 440mm – 605mm (17 5/16" – 23 13/16")
- Boom arm: 505mm – 845mm (19 7/8" – 33 1/4")
- Weight: 3.1kg (6.9lbs)
- Black Finish

IRON WORKS TOUR ROUND BASE TELESCOPING BOOM STAND



MS456RBK

- Cast Grip Boom Tilter
- Die-Cast Locking Thumb Nut
- Sure-Cast Adjustment Collar
- Iron-Core Telescoping Boom Arm
- Heavier Round Cast Base
- Height: 1000mm – 1705mm (39 1/4" – 67 1/8")
- Boom arm: 505mm – 845mm (19 7/8" – 33 1/4")
- Weight: 7.1kg (15.7lbs)
- Black Finish

IRON WORKS TOUR ROUND BASE LOW PROFILE TELESCOPING BOOM STAND



MS456RLBK

- Cast Grip Boom Tilter
- Die-cast Locking Thumb Nut
- Sure-Cast Adjustment Collar
- Iron-Core Telescoping Boom Arm
- Cast round base with T-bolt pipe fixing devise
- Height: 935mm – 1680mm (36 13/16" – 66 1/8")
- Boom arm: 505mm – 845mm (19 7/8" – 33 1/4")
- Weight: 3.9kg (8.6lbs)
- Black Finish

IRON WORKS TOUR STRAIGHT STAND



MS450BK

- Die-cast Locking Thumb Nut
- Sure-Cast Adjustment Collar
- Latch-Lok Sleeve Insert
- Height: 910mm – 1580mm (35 13/16" – 62 3/16")
- Weight: 2.3kg (5.1lbs)
- Black Finish

IRON WORKS TOUR ROUND BASE STRAIGHT STAND



MS450DBK

- Die-cast Locking Thumb Nut
- Sure-Cast Adjustment Collar
- Latch-Lok Sleeve Insert
- Cast round base with T-bolt pipe fixing devise
- Height: 935mm – 1680mm (36 13/16" – 66 1/8")
- Weight: 3.9kg (8.6lbs)
- Black Finish

IRON WORKS TOUR TABLE TOP STAND



MS50BK

- Lighter smaller zinc die-cast round base
- 2 stage aluminum pipe construction
- Height: 220mm – 370mm (8 5/8" – 14 9/16")
- Weight: 1.1kg (2.5lbs)
- Black Finish

BOOM STAND



MS205

- Cast Grip Boom Tilter
- Height: 960mm – 1600mm (37 13/16" – 63")
- Boom arm: 830mm (32 11/16")
- Weight: 3.2kg (7.1 lbs)
- Chrome Finish

BOOM STAND



MS205BK

- Cast Grip Boom Tilter
- Height: 960mm – 1600mm (37 13/16" – 63")
- Boom arm: 830mm (32 11/16")
- Weight: 3.2kg (7.1 lbs)
- Black Finish

LOW PROFILE BOOM STAND



MS205ST

- Cast Grip Boom Tilter
- Height: 430mm – 560mm (17 1/8" – 22 1/16")
- Boom arm: 510mm (20 1/16")
- Weight: 2.3kg (5.1 lbs)
- Chrome Finish

LOW PROFILE BOOM STAND



MS205STBK

- Cast Grip Boom Tilter
- Height: 430mm – 560mm (17 1/8" – 22 1/16")
- Boom arm: 510mm (20 1/16")
- Weight: 2.3kg (5.1 lbs)
- Black Finish

BOOM ARM



MS756BB

- Vice-Grip Boom Tilter with Iron-Core Telescoping Boom Arm

BOOM ARM



MS456BB

- Cast-Grip Boom Tilter with Iron-Core Telescoping Boom Arm

BOOM ARM



MS455BB

- Cast-Grip Boom Tilter with Standard Boom Arm

CORD CLIP



CC5

For 15.9 mm (5/8") diameter tube.

CORD CLIP



CC7

For 22.2 mm (7/8") diameter tube.

DIE-CAST LOCKING THUMB NUT



DTLN5

For 5/8" connector
Not only does the thumb nut's larger, sure-grip design allow greater leverage for faster, easier set-up and breakdown, its high quality zinc threads and walls are built to handle pressure for years to come.

RUBBER FOOT



756RF

TAMA's extra thick rubber foot covers "float" the stand, isolating the microphone from floor vibrations. (for 19.1mm diameter leg)

TAMA PERCUSSION

For more than 40 years, TAMA has been inspiring drummers around the world with its unique range of original percussion instruments. Combining the influences of global musical cultures with modern technology, TAMA has given drummers and percussionists of every genre a new lease on creativity with the unique voices these instruments provide.

GONG BASS DRUM



BG20RPBK MADE IN JAPAN

14"x20" Starclassic Bubinga Gong Bass Drum

An early TAMA original, the Gong Bass Drum uses a 22" head mounted Tympani style on a 20" shell with no bottom head. This design produces a thunderous, low-end sound with excellent sustain, characteristic of the large Taiko drums of ancient Japan. The Gong Bass uses a 8mm thick Starclassic Bubinga shell, and is fitted with chrome hardware.

*Gong Bass Drums is available in Piano Black (PBK) finish only.

STEEL MINI-TYMPMS



MT68ST

4"x6" + 4"x8"

Steel Mini-Tympms come with an L-rod (LLT) and multi-clamp (MC66).

STEEL MINI-TYMPMS



MT810ST

4"x8" + 4"x10"

Steel Mini-Tympms come with an L-rod (LLT) and multi-clamp (MC66).

STEEL MINI-TYMPMS



MT1012ST NEW

4"x10" + 4"x12"

Steel Mini-Tympms come with an L-rod (LLT) and multi-clamp (MC66).

JINGLE RING



TJR7

The Jingle Ring is a slim tambourine that can be mounted on a hi-hat stand or as a separate item. It features 9 pairs of nickel "jingles" that produce a bright, clear, tambourine sound. Its eyebolt style clamp secures it firmly in place for playing, and allows mounting of the Jingle Ring to the hi-hat rod or the 8mm diameter rod of a boom arm.

OCTOBAN SET



7850N2H

2pc High-pitch set w/HOW29WN stand

OCTOBAN SET



7850N2L

2pc Low-pitch set w/HOW29WN stand

OCTOBAN SET



7850N4H

4pc High-pitch set w/HOW49WN stand

OCTOBAN SET



7850N4L

4pc Low-pitch set w/HOW49WN stand

OCTOBAN



OCT280N

280mm (11") depth

OCTOBAN



OCT301N

301mm (11 3/4") depth

OCTOBAN



OCT343N

343mm (13 1/2") depth

OCTOBAN



OCT390N

390mm (15 1/2") depth

OCTOBAN



OCT443N

443mm (17 1/2") depth

OCTOBAN



OCT472N

472mm (18 1/2") depth

OCTOBAN



OCT536N

536mm (21") depth

OCTOBAN



OCT600N

600mm (23 1/2") depth

OCTOBAN STAND



HOW29WN

for 2pcs octobans

OCTOBAN STAND



HOW49WN

for 4pcs octobans

OCTOBAN HOLDER FOR DRUM RACK



OA29

for 2pcs octobans

OCTOBAN HOLDER FOR DRUM RACK



OA49

for 4pcs octobans

PRACTICE TOOLS

Our unique practice tools make your percussive education more enjoyable and productive.

PRACTICE PAD



TSP10

TAMA's 10" practice pad is a single sided rubber pad. The rubber portion is wrapped around a wooden board for a natural, bouncy feel. Slightly thicker soft urethane material on the reverse side helps absorb impact and reduce volume.

PRACTICE PAD STAND



HS40TP

The HS40TP training pad stand can hold pads between 6 and 10 inch diameters. The rubber grips of the basket can also be reversed for holding smaller pads more securely. An extension pipe is included for when practicing standing up is desired.

-Height Adjustment Range
w/o extension pipe: 582 – 732mm (23" – 28 3/4")
w/ extension pipe: 848 – 990mm (33 3/8" – 39")
*Measured from the top surface of a 10 inch training pad to the floor

MESH HEAD



MH8T

MH8T (8")
MH10T (10")
MH12T (12")
MH13T (13")
MH14T (14")
MH16T (16")
MH18B (18")
MH22B (22")

SILENT TIPS



TCP20

TAMA TCP20 is a pair of silicone rubber tips that fit over most drum stick models. These tips make it easy and convenient to practice silently, anytime, anywhere.

BAGS

TAMA's heavy duty bags protect your drums from damage during transportation.

POWERPAD BAG -Tom Tom-



PBT8
7"x8" Tom Tom

POWERPAD BAG -Tom Tom-



PBT10
8"x10" Tom Tom

POWERPAD BAG -Tom Tom-



PBT12
9"x12" Tom Tom

POWERPAD BAG -Tom Tom-



PBT13
10"x13" Tom Tom

POWERPAD BAG -Tom Tom-



PBT14
11"x14" Tom Tom

POWERPAD BAG -Floor Tom-



PBF14
14"x14" Floor Tom

POWERPAD BAG -Floor Tom-



PBF16
16"x16" Floor Tom

POWERPAD BAG -Bass Drum-



PBB18
16"x18" Bass Drum or Floor Tom

POWERPAD BAG -Bass Drum-



PBB20
18"x20" Bass Drum

POWERPAD BAG -Bass Drum-



PBB22
18"x22" Bass Drum

POWERPAD BAG -Bass Drum-



PBB22X
20"x22" Bass Drum

POWERPAD BAG -Bass Drum-



PBB24
18"x24" Bass Drum

POWERPAD BAG -Snare Drum-



PBS1455
5.5"x14" Snare Drum

POWERPAD BAG -Snare Drum-



PBS1465
6.5"x14" Snare Drum

POWERPAD BAG -Snare Drum-



PBS1480
8"x14" Snare Drum

POWERPAD BAG -Hardware-



PBH02L
880 (L) x150 (W) x200 (H) mm
(34 5/8" x 5 7/8" x 7 7/8")

POWERPAD BAG -Hardware-



PBH05
850 (L) x 320 (W) x220 (H) mm
(33 1/2" x 12 5/8" x 8 5/8")

POWERPAD BAG -Cymbal-



PBC22
22" compartment dividers (3pcs) and 15" compartment dividers (3pcs) included.

POWERPAD BAG -Twin Pedal-



PBP200

450 (L) x300 (W) x 200 (H) mm
(7 7/8" x 17 3/4" x 11 13/16")

POWERPAD BAG -Single Pedal-



PBP100

220 (D) x190 (W) x 400 (H) mm
(8 5/8" x 7 1/2" x 15 3/4")

POWERPAD BAG -Drum Throne-



PBTH15

-Carries any TAMA drum throne
-Carries 14" snare drum and snare drum stand

POWERPAD BAG -Stick-



PBS50

Stores about 24 pairs of sticks & mallets

POWERPAD BAG -Stick-



PBS24

Stores about 12 pairs of sticks & mallets

POWERPAD BAG -Stick-



TSB12BK

Black
Stores about 6 pairs of sticks

POWERPAD BAG -Stick-



TSB12NB

Navy Blue
Stores about 6 pairs of sticks

POWERPAD BAG -Stick-



TSB12BE

Beige
Stores about 6 pairs of sticks

POWERPAD BAG -Stick-



TSB12WR

Wine Red
Stores about 6 pairs of sticks

STANDARD SERIES DRUM BAG SET



DSS52K

18"x22"BD
8"x10"TT
9"x12"TT
16"x16"FT
6.5"x14"SD

STANDARD SERIES DRUM BAG SET



DSS50S

NEW

18"x20"BD
8"x10"TT
9"x12"TT
14"x14"FT
6.5"x14"SD

STANDARD SERIES DRUM BAG SET



DSS62S

NEW

18"x22"BD
8"x10"TT
9"x12"TT
14"x14"FT
16"x16"FT
6.5"x14"SD

STANDARD SERIES DRUM BAG SET



DSS48LJ

NEW

(for Club-JAM kit)
12"x18"BD
8"x10"TT
7"x14"FT & 5"x13"SD (1bag)

STANDARD SERIES DRUM BAG SET



DSS48S

NEW

14"x18"BD
9"x12"TT
14"x14"FT
6.5"x14"SD

STANDARD SERIES DRUM BAG SET



DSS72S

NEW

18"x22"BD
7"x8"TT
8"x10"TT
9"x12"TT
14"x14"FT
16"x16"FT
6.5"x14"SD

HARDWARE BAG FOR THE CLASSIC HARDWARE



SBH01

NEW

670 (L) x 180 (W) x 190 (H) mm
(26 2/5" x 7 1/10" x 7 1/2")

ACCESSORIES

RHYTHM WATCH



RW200

Tempo Range: 30-250 BPM
Tempo, Beat & Sound Memory: 30 Songs
Beats: 0-9
Display: LCD with BACK LIGHT
Size: 127 x 35 x 150mm (5" x 1.4" x 6")
Weight: 285g including battery
Power Supply: 9V Battery (S-006P) or DC9V 200mA adapter

RHYTHM WATCH MINI



RW30

Tempo Range: 30-250 BPM
Beats: 0-9
Display: LCD display with BACK LIGHT
Size: 61 x 25 x 118mm (2 1/2" x 1" x 4 5/8")
Weight: 90g including battery
Power Supply: 2 x AAA Batteries (3V)

RHYTHM WATCH HOLDER



RWH10

for RW200, RW105 & RW100

TENSION WATCH



TW200

The TW200 TAMA Tension Watch is very compact and is equipped with an easy to read dial. It comes with a detachable nylon bumper to ensure consistent measuring distance from the hoop, resulting in an evenly tensioned drum for the best sound.

TENSION WATCH CARRYING BAG



TW2B

This bag is specially designed to carry the TW200 Tension Watch safely and securely.

TENSION WATCH



TW100

The TW100 measures actual head tension and features an easy-to-read meter, so you can record the numbers and duplicate your best tuning time after time. You can also use the sample tunings suggested in the directions.

DRUMMER'S GLOVE



TDG10M/L

(Pair)
TDG10M (Medium)
TDG10L (Large)

WOOD HOOP SAVER



WHP2

(2pcs / set)
Special adhesive pieces protect your wood hoop from being scratched by preventing the bass drum pedal from twisting or slipping.

MULTI TOOL



TMT9

Quick access multi tool for drums
-Hex Wrench 5.0mm/4.0mm/3.0mm/2.5mm/
2.0mm, Keychain Link, Hex Nut Driver, Phillips
Screwdriver, Drum Keys (x2)

STAND WEIGHT



TSW10

TAMA hardware is highly regarded for its quality and stability. But sometimes you need a little extra stability – either for extremely hard hitting, or if the playing surface is uneven. To meet that need, we present TAMA Stand Weights, which enable you to stabilize your stand firmly on any surface simply by looping the weight around the tripod base.
Weight: 3kg (6.6lb)

DRUM RUG -TAMA Logo Pattern-



TDRTL

1800mm x 2000mm
(70 7/8" x 78 3/4")

DRUM RUG -Oriental Pattern-



TDROR

1800mm x 2000mm
(70 7/8" x 78 3/4")

REMO FIBERSKYN POWERSTROKE 3 DIPLOMAT



RF22BMST

RF18BMST (18")
RF20BMST (20")
RF22BMST (22")
RF24BMST (24")
RF26BMST (26")

WHITE COATED HEADS



CT22BMOT

(TAMA & Starclassic Logo)
CT18BMOT (18")
CT20BMOT (20")
CT22BMOT (22")
CT24BMOT (24")
CT26BMOT (26")

FIBER LAMINATED HEADS



FB22BMFS

(TAMA & Starclassic Logo)
FB18BMFS (18")
FB20BMFS (20")
FB22BMFS (22")
FB24BMFS (24")

BLACK HEADS



BK22BMTT

(TAMA & Starclassic Logo)
BK18BMTT (18")
BK20BMTT (20")
BK22BMTT (22")
BK24BMTT (24")
BK26BMTT (26")

SMOOTH WHITE HEADS



SW22BMTT

(TAMA & Starclassic Logo)
SW20BMTT (20")
SW22BMTT (22")
SW24BMTT (24")

FIBER LAMINATED HEADS -BLACK-



BK22BMFH

(TAMA Logo for Superstar Hyper-Drive)
BK20BMFH (20")
BK22BMFH (22")

NEW

WHITE COATED HEADS -TAMA LOGO-



CT22BMSV

(TAMA Logo)
CT18BMSV (18")
CT20BMSV (20")
CT22BMSV (22")
CT24BMSV (24")

BLACK HEADS -TAMA LOGO-



BK22BMWS

(TAMA Logo)
BK20BMWS (20")
BK22BMWS (22")
BK24BMWS (24")

BASS DRUM HEAD



CT16BMMJ

16" / "Metro-JAM" Kit front side

BASS DRUM HEAD



CL16BMSMJ

16" / "Metro-JAM" Kit batter side

DRUM KEY



TDK10

Chrome

DRUM KEY



TDK10BN

Black Nickel

DRUM KEY



6560

TENSION LOCK



TTL10

(10pcs/set)

NEW

The Tension Lock is an accessory to prevent tension bolts from loosening while playing. Simply set it on the tension bolt head – its unique shape fits perfectly. On the other hand, you can tune the drum without having to detach the Tension Lock, thanks to an elastic O-ring around its hole. It is a small accessory, but filled with TAMA's unique ideas.

DIE-CAST HOOPS



MDH1410

Made of diecast zinc, TAMA's diecast hoops deliver an incredibly sharp, solid rim shot that cannot be found in any other hoop.

MDH148 (14" 8 hole batter side)
MDH14S8 (14" 8 hole snare side)
MDH1410 (14" 10 hole batter side)
MDH14S10 (14" 10 hole snare side)

2.3mm BRASS MIGHTY HOOPS



MFB1410N

Brass Mighty Hoop provides a warm and open sound with mild attack and long sustain.

MFB1410N (14" 10 hole batter side)
MFB14S10N (14" 10 hole snare side)

2.3mm STEEL MIGHTY HOOPS



MFM1410

Steel Mighty Hoop provides a bright and open sound.

MFM148 (14" 8 hole batter side)
MFM14S8 (14" 8 hole snare side)
MFM1410 (14" 10 hole batter side)
MFM14S10 (14" 10 hole snare side)

2.3mm SOUND ARC HOOPS



MSH1410

Steel Sound Arc Hoop enhances the natural tone of the snare drum and offers sensitivity, precise tuning, and control.

MSH1410 (14" 10 hole batter side)
MSH14S10 (14" 10 hole snare side)

2.3mm BRASS SOUND ARC HOOPS



MSB148D

Brass Sound Arc Hoop provides an open sound with rich harmonic overtones, made of brass with an inward curved shape.

MSB148D (14" 8 hole batter side)
MSB14S8D (14" 8 hole snare side)

MAPLE WOOD HOOPS



WMH1408B

Wood Hoop provides a warm, woody sound with soft attack. Can be mounted on a standard 14" snare drum stand.

WMH1408B (14" 8 hole batter side)
WMH1408S (14" 8 hole snare side)
WMH1410B (14" 10 hole batter side)
WMH1410S (14" 10 hole snare side)

SUPER SENSITIVE HI-CARBON SNARE WIRES

MS20RL14C

MS20RL13C (13" 20 strands Hi-Carbon Steel)
MS20RL14C (14" 20 strands Hi-Carbon Steel)



SUPER SENSITIVE HI-CARBON SNARE WIRE FOR CONCERT

MS20L14C8 NEW

MS20L14C8 (14" 20 strands Hi-Carbon Steel)



STAINLESS STEEL STRAIGHT SNARE WIRE

MS20M14ST NEW

MS20M14ST (14" 20 strands Steel)



STARCLASSIC SNARE WIRES -CARBON STEEL-

MS20SN14S

MS20SN10S (10" 20 strands Carbon Steel)
MS20SN12S (12" 20 strands Carbon Steel)
MS20SN13S (13" 20 strands Carbon Steel)
MS20SN14S (14" 20 strands Carbon Steel)



STARCLASSIC SNARE WIRES -BELL BRASS-

MS20SN14B

MS20SN14B (14" 20 strands Bell Brass)



STARCLASSIC SNARE WIRES -HI-CARBON STEEL-

MS20SN14C

MS20SN13C (13" 20 strands Hi-Carbon Steel)
MS20SN14C (14" 20 strands Hi-Carbon Steel)



REGULAR SNARE WIRES -CARBON STEEL-

MS12R14S

(14" 12 strands Carbon Steel)



REGULAR SNARE WIRES -CARBON STEEL-

MS20R14S

(14" 20 strands Carbon Steel)

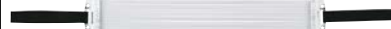

REGULAR SNARE WIRES -CARBON STEEL-

MS30R14S

(14" 30 strands Carbon Steel)



REGULAR SNARE WIRES -CARBON STEEL-

MS42R14S

(14" 42 strands Carbon Steel)



REGULAR SNARE WIRES -HI-CARBON STEEL-

MS42R14C

(14" 42 strands Hi-Carbon Steel)

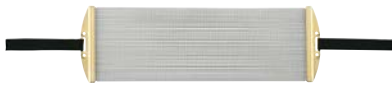

HOLD TIGHT™ WASHERS

SRW620P

(20pcs/set)

The rubber rings inside of the cup-shaped stainless steel washers absorb impact vibrations and keep the hoop and tension bolts in constant contact to prevent from loosening of tension.



PLASTIC WASHERS

PW620

(20pcs/set)

2.5mm thick nylon washers decrease noise and make tuning easier and more stable.



METAL WASHERS

MW620

(20pcs/set)

Standard metal tension bolt washers.



SNARE WIRE STRAPS

MST20

(2pcs/set)

These flexible yet durable 15mm wide nylon snare wire straps are featured on all TAMA snare drums except STAR, STARPHONIC, JD146 and PE106M



SNARE WIRE STRINGS

SPC50P4

(2prs/pack)

The amazingly durable and flexible snare wire string is made of Dupont Kevlar® cable wrapped in polyester fiber for an even higher tensile strength than steel wire. (Kevlar® is a registered trademark of Dupont® Corporation.)

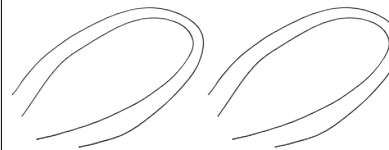

DRUM CLEANING CLOTH

TDC1000

TAMA TDC1000 features two distinct surfaces (the material made in JAPAN by UNITIKA TRADING CO., LTD.). Flat fiber surface is designed for the hardware and cymbal. Soft fiber surface excels at dry cleaning for daily Drum care needs.



POWER-STRIKE COBRA BEATER

CB900PS

Felt



ACCU-STRIKE COBRA BEATER

CB900AS

Rubber



PROJECTOR BEATER

PB90F

Felt



COBRA BEATER -Felt-



CB90F

Felt

COBRA BEATER -Rubber-



CB90R

Rubber

COBRA BEATER -Wood-



CB90W

Wood

POWER-STRIKE COBRA BEATER HEAD



CB900PSH

Felt

ACCU-STRIKE COBRA BEATER HEAD



CB900ASH

Rubber

PROJECTOR BEATER HEAD



PB90FH

Felt

COBRA BEATER HEAD -Felt-



CB90FH

Felt

COBRA BEATER HEAD -Rubber-



CB90RH

Rubber

COBRA BEATER HEAD -Wood-



CB90WH

Wood

DUAL SIDED BEATER -Felt-



DS30

Felt

DUAL SIDED BEATER -Felt-



DS30G

Felt

THE CLASSIC BEATER -Felt-



CLB30F

Felt

NEW

TRADITIONAL BEATER -Felt-



TTB30F

Felt

TRADITIONAL BEATER -Wood-



TTB30W

Wood

SOFT SOUND BEATER



BSQ10S

NEW

A quieter bass drum is now as simple as switching the beater on your pedal. Soft Sound Beater provides a significant decrease in volume, but allows you to use your regular bass drum pedal and bass drum head with a natural and accurate feel. It's useful not only for low volume gigs and applications but also practice at low volume.

TOE STOPPER



HP90081

BEATER BALANCER



BC7

TIGHT LOCK



TLK5

SPRING FOR SPEED COBRA



HP9107S

SPRING -Regular-



HP9007R

SPRING -Heavy-

HP9007H



COBRA COIL

CC900S

The Cobra Coil is a steel spring which assists in the return of the footboard to its original position, so the feel of Speed Cobra becomes even more unreal. Even better, the Cobra Coil can be adjusted to different positions, forward or backward, on the base plate.



DRUM HAMMER

DH7



TWIN PEDAL ATTACHMENT

TPA90

Specially designed attachment to connect Speed Cobra and Iron Cobra 900 series pedals with Speed Cobra and Iron Cobra 900 series Hi-hat stands.



IRON COBRA PEDAL CASES

PC900S/PC900TW

PC900S (for Iron Cobra Single Pedal)
PC900TW (for Iron Cobra Twin Pedal)



SPEED COBRA PEDAL CASES

PC910S/PC910TW

PC910S (for Speed Cobra Single Pedal)
PC910TW (for Speed Cobra Twin Pedal)



1ST CHAIR ROUND RIDER XL SEAT -Cloth Top-

HTS8BC



1ST CHAIR ROUND RIDER XL SEAT

HTS8B



1ST CHAIR ROUND RIDER XL SEAT -Red-

HTS8R



1ST CHAIR ERGO-RIDER SEAT -Cloth Top-

HTS7BC



1ST CHAIR ERGO-RIDER SEAT

HTS7B



1ST CHAIR GLIDE RIDER SEAT -Cloth Top-

HTS5BCN



1ST CHAIR ROUND RIDER SEAT -Cloth Top-

HTS4BC



1ST CHAIR ROUND RIDER SEAT

HTS4B



1ST CHAIR THRONE BASE -HYDRAULIX-

HSB5N

*Seat holder included.



1ST CHAIR THRONE BASE -Quartet-

HSB4N



1ST CHAIR THRONE BASE -Trio-

HSB3N



1ST CHAIR THRONE BASE -Trio-

HSB3

for Round Rider Series



1ST CHAIR BACKREST ATTACHMENT

HTB5B

for any 1st Chair thrones



TAMA LOGO STICKER -White-

TLS120WH

60mm x 280mm
(2 3/8" x 11 1/32")



TAMA LOGO STICKER -White-

TLS100WH

50mm x 230mm
(1 31/32" x 9 1/16")



TAMA LOGO STICKER -White-

TLS80WH

40mm x 190mm
(1 9/16" x 7 1/2")



TAMA LOGO STICKER -White-

TLS70WH

35mm x 150mm
(1 3/8" x 5 7/8")



TAMA LOGO STICKER -Black-

TLS120BK

60mm x 280mm
(2 3/8" x 11 1/32")



TAMA LOGO STICKER -Black-

TLS100BK

50mm x 230mm
(1 31/32" x 9 1/16")



TAMA LOGO STICKER -Black-

TLS80BK

40mm x 190mm
(1 9/16" x 7 1/2")



TAMA LOGO STICKER -Black-

TLS70BK

35mm x 150mm
(1 3/8" x 5 7/8")



TUNE UP OIL

TOL2

Machine oil for lubricating the moving parts of stands, pedals, and tension bolts. Also protects pedal chains from rust.



SONIC MUTE

TSM01

(2pcs/set)
Removable, reusable & reliable mute patch.
Adjustable for optimum precision and control.
(Wash lightly to restore adhesion).



MEMORY LOCK

ML11

for 10.5mm diameter L-rod



MEMORY LOCK



ML12
for 10.5-12mm diameter boom arm

MEMORY LOCK



ML191C
for 19.1mm diameter pipe

MEMORY LOCK



ML191N
for 19.1mm diameter pipe

MEMORY LOCK



ML222C
for 22.2mm diameter pipe

MEMORY LOCK



ML222NT
for 22.2mm diameter pipe

MEMORY LOCK



ML254TC
for 25.4mm diameter pipe

MEMORY LOCK



ML254C
for 25.4mm diameter pipe

MEMORY LOCK



ML28C
for 28.6mm diameter pipe

QUICK-SET CYMBAL MATE



QC8
(M8)

QUICK-SET CYMBAL MATE (4pcs/set)



QC8B4
(M8: 4pcs/pack)

CYMBAL MATE



CM8P
(M8: 2pcs/pack)

RING-TRUE FELT for STAR Hardware



RTF35P
(2pcs/pack)

FELT WASHER



7081P
(2pcs/pack)

REVERSIBLE CYMBAL BOTTOM



RB8P
(M8: 2pcs/pack)

STAR HARDWARE CYMBAL BOTTOM



CB8P
(M8: 2pcs/pack)

CYMBAL PROTECTION SLEEVE



CPS8P
(M8: 2pcs/pack)

HAT STACK



CSH5 NEW
-Easily attach a small cymbal to hi-hat rod
-Compact size and lightweight for easy transport and storage - 25mm (1") diameter x 40mm (1.5") height
-Ability to adjust cymbal sustain

QUICK-SET HI-HAT CLUTCH



QHC7
With just one touch, the Quick-Set Clutch can be attached or removed - simply push the button on the side of the clutch. The clutch also allows the top hi-hat cymbal to float more freely, maximizing the natural resonance of the cymbals.
(Fits 7mm or smaller diameter pull rod)

SWING LOCK CLUTCH



SLC08
This allows the top hi-hat cymbal to float more freely, maximizing the natural resonance of the cymbals.
(Fits 6.3mm diameter pull rod)

SECURITY CLUTCH



CL08
Having your hi-hat clutch come loose is now a thing of the past with TAMA's Security Clutch. When the T-bolt is tightened, bottom lock nut and top section press on the rod for complete security.
(Fits 6.3mm diameter pull rod)

HI-HAT TENSION RODS



HH9053/HH905D3S

Tension Rod w/ Plastic Nut (M6)

HH9053 (Long / 500mm (19 11/16"))
HH905D3S (Short / 350mm (13 3/4"))

REMOTE HI-HAT STAND CABLE



HH905RH2L/HH905RH2S

Exchangeable Cable for HH905RH **NEW**

HH905RH2L (Long / 2,300mm (90 1/2"))
HH905RH2S (Short / 1,200mm (47 1/4"))

HI-HAT CLUTCH FELT WASHERS



CL0813P

(2pcs/pack)

QUICK-LOCK TOM BRACKET



MQMPTCH

(for tom tom/Chrome)

- Quick and easy setup in position
- Enhanced resonance with rubber lining

QUICK-LOCK TOM BRACKET



MQMPTBN

(for tom tom/Black Nickel)

- Quick and easy setup in position
- Enhanced resonance with rubber lining

QUICK-LOCK TOM BRACKET



MQMPFCH

(for floor tom/Chrome)

- Quick and easy setup in position
- Enhanced resonance with rubber lining

QUICK-LOCK TOM BRACKET



MQMPFBN

(for floor tom/Black Nickel)

- Quick and easy setup in position
- Enhanced resonance with rubber lining

SOUND FOCUS PAD -for Cocktail-JAM-



SFP530

Bass Drum Mute for Cocktail-JAM kits **NEW**

SOUND FOCUS PAD -for Cocktail-JAM Mini-



SFP480

Bass Drum Mute for Cocktail-JAM Mini kits **NEW**

DRUM STICKS

TAMA drum sticks are molded under strict quality control standards from carefully selected wood materials and are renowned for their consistent high quality.

TRADITIONAL SERIES -Japanese Oak-

7A

MADE IN JAPAN

Diameter: 13mm (0.511")
Length: 390mm (15 3/8")
Tip Style: 7A



TRADITIONAL SERIES -Japanese Oak-

5A

MADE IN JAPAN

Diameter: 14 mm (0.550")
Length: 406mm (16")
Tip Style: 5A



TRADITIONAL SERIES -Japanese Oak-

8A

MADE IN JAPAN

Diameter: 14 mm (0.550")
Length: 406mm (16")
Tip Style: 8A



TRADITIONAL SERIES -Japanese Oak-

5B

MADE IN JAPAN

Diameter: 15 mm (0.590")
Length: 406mm
Tip Style: 5B



OAK LAB SERIES -Smash-

OLSM

NEW MADE IN JAPAN

Weight and balance for huge power.

Diameter: 15 mm (0.590")
Length: 419 mm (16 1/2")
Tip Style: Acorn



OAK LAB SERIES -Resonator-

OLRE

NEW MADE IN JAPAN

Heavy for rich tones. Quick rebound.

Diameter: 15.25 mm (0.600")
Length: 410 mm (16 5/32")
Tip Style: Arrow



OAK LAB SERIES -Fast Blast-

OLFA

NEW MADE IN JAPAN

(Natural / Uncoated)
Modified 5A for more speed. Large tip and Oak enhances volume.

Diameter: 14 mm (0.550")
Length: 406mm (16")
Tip Style: Large Ball



OAK LAB SERIES -Swingin'-

OLSW

NEW MADE IN JAPAN

Oak provides a bright cymbal tone and enhanced cross stick sound.

Diameter: 12.75 mm (0.500")
Length: 403 mm (15 7/8")
Tip Style: Oval



OAK LAB SERIES -Full Balance-

OLFU

NEW **MADE IN JAPAN**

Weighted for accuracy and control.

Diameter: 14.5 mm (0.570")
Length: 406 mm (16")
Tip Style: True Round



REDZONE -Japanese Oak-

5ARZ

MADE IN JAPAN

(Silver Logo)

Diameter: 14 mm (0.550")
Length: 419 mm (16 1/2")
Tip Style: Nylon



REDZONE -Japanese Oak-

5BRZ

MADE IN JAPAN

(Silver Logo)

Diameter: 15 mm (0.590")
Length: 419 mm (16 1/2")
Tip Style: Nylon



REDZONE -Japanese Oak-

5ARZK

MADE IN JAPAN

(Silver Logo)

Diameter: 14 mm (0.550")
Length: 419 mm (16 1/2")
Tip Style: Knocker



RHYTHMIC FIRE -Japanese Oak-

7AF

MADE IN JAPAN

Diameter: 13mm (0.511")
Length: 390mm (15 3/8")
Tip Style: 7A



RHYTHMIC FIRE -Japanese Oak-

5AF

MADE IN JAPAN

Diameter: 14 mm (0.550")
Length: 406 mm (16")
Tip Style: 5A



RHYTHMIC FIRE -Japanese Oak-

5BF

MADE IN JAPAN

Diameter: 15 mm (0.590")
Length: 406 mm (16")
Tip Style: 5B



DIRK VERBEUREN MODEL -Japanese Oak-

ODVM

MADE IN JAPAN

Dirk Verbeuren (MEGADETH)

Diameter: 16mm (0.629")
Length: 406mm (16")



MARIO DUPLANTIER MODEL -American Hickory-

HMD

MADE IN JAPAN

Mario Duplantier (Gojira)

Diameter: 16.5mm (0.649")
Length: 432mm (17")



JEREMY COLSON MODEL -Japanese Oak-

HJCS

MADE IN JAPAN

Jeremy Colson (Steve Vai)

Diameter: 16.5mm (0.649")
Length: 422mm (16.6")



RHYTHM MATE SERIES -Hickory-

HRM5A

Diameter: 14mm (0.550")
Length: 406mm (16")



RHYTHM MATE SERIES -Hickory-

HRM5B

Diameter: 15mm (0.590")
Length: 406mm (16")



RHYTHM MATE SERIES -Hickory-

HRM7A

Diameter: 13.5mm (0.530")
Length: 394mm (15 1/2")



RHYTHM MATE SERIES -Hickory-

HRM2B

Diameter: 16mm (0.629")
Length: 406mm (16")



RHYTHM MATE SERIES -Maple-

MRM5A

Diameter: 14mm (0.550")
Length: 406mm (16")



RHYTHM MATE SERIES -Maple-

MRM5B

Diameter: 15mm (0.590")
Length: 406mm (16")



RHYTHM MATE SERIES -Maple-

MRM7A

Diameter: 13.5mm (0.530")
Length: 394mm (15 1/2")



RHYTHM MATE SERIES -Maple-

MRM2B

Diameter: 16mm (0.629")
Length: 406mm (16")





TAMA[®]

 Tama Drums  TAMAofficial  officialtamadrums  @TAMAofficial

www.tama.com

1726 Winchester Road, Bensalem, PA 19020 • U.S.A.
Actual product colors may not exactly be the same as the one shown on the catalog photos due to lighting and photo resolution.
All specifications are subject to change without notice.
©2018 TAMA DRUMS All rights reserved.