



Agreement No. CE32/2004(GE)

Upgrading/ Improvement of Roadside Slope/
Retaining Walls on Hong Kong Island (2005-
2008 Programme) – Investigation, Design and
Construction

Heritage Impact Assessment Report for Feature No. 11SW-B/R93 (Sub- division 1), Duddell Street

Report Ref: M45/200

Final | June 2013

Document Verification

ARUP

Job title		Upgrading/ Improvement of Roadside Slope/ Retaining Walls on Hong Kong Island (2005 – 2008 Programme) – Investigation, Design and Construction		Job number 24506/10	
Document title		Heritage Impact Assessment Report for Feature No. 11SW-B/R93 (Sub-division 1), Duddell Street		File reference	
Document ref		ARUP/HYD/(HY/2008/18)/M45/200/			
Revision	Date	Filename	Report.docx		
Final	19/06/13	Description	Heritage Impact Assessment Report		
			Prepared by	Checked by	Approved by
		Name	Eric Chan	Eddie Chan	Albert Ho
		Signature			
		Filename			
		Description			
			Prepared by	Checked by	Approved by
		Name			
		Signature			
		Filename			
		Description	Heritage Impact Assessment Report		
			Prepared by	Checked by	Approved by
		Name			
		Signature			
		Filename			
		Description	Heritage Impact Assessment Report		
			Prepared by	Checked by	Approved by
		Name			
		Signature			

Issue Document Verification with Document



Agreement No. CE32/2004(GE)

**Upgrading/ Improvement of Roadside Slope/ Retaining
Walls on Hong Kong Island (2005-2008 Programme) –
Investigation, Design and Construction**

Heritage Impact Assessment Report
for
Feature No. 11SW-B/R93 (Sub-division 1), Duddell Street



June 2013

Ove Arup & Partners Hong Kong Ltd
Level 5, Festival Walk, 80 Tat Chee Avenue, Kowloon Tong, Kowloon, Hong Kong
Tel +852 2528 3031 Fax +852 2268 3970
www.arup.com

Contents

	Page
1. Introduction	
1.1 Background of the Project	1
1.2 Brief and Objectives of the Report	2
1.3 Proposed Upgrading/ Improvement Works	3
1.4 Methodology	5
1.4.1 Baseline Study	5
1.4.2 Impact Assessment	5
1.4.3 Mitigation Measures	6
1.5 Definitions	6
2. Baseline Study	
2.1 Desk-top Researches	10
2.1.1 History of the Duddell Street Steps and Gas Lamps	10
2.1.2 Maintenance Responsibilities of the Declared Monuments ...	12
2.1.3 Investigation on Disused Tunnels	13
2.1.4 Vegetation in the Vicinity of the Heritage Site	15
2.1.5 Existing Utilities	15
2.2 Field Evaluation	16
2.2.1 Field Evaluation on the Declared Monuments.....	16
2.2.1.1 Parapet Walls.....	16
2.2.1.2 Granite Stone Staircase.....	17
2.2.1.3 Granite Stone Handrailings.....	17
2.2.1.4 Gas Lamp.....	18
2.2.1.5 Granite Masonry Blocks.....	19
2.2.1.6 Storerooms underneath the Staircase.....	19
2.2.2 Field Evaluation on the Existing Disused Tunnels.....	20
2.2.3 Field Evaluation on the Adjacent Buildings.....	22
2.2.4 Field Evaluation on nearby Footpath/ Pavement.....	22
2.2.5 Field Evaluation on Existing Utilities on the Feature.....	23
2.2.6 Field Evaluation on Existing Trees.....	23
3. Assessment of Cultural Significance	
3.1 Criteria of Assessment.....	25
3.2 Statement of Cultural Significance.....	25
3.2.1 Social Significance.....	25
3.2.2 Historical Significance.....	26
3.2.3 Architectural and Aesthetic Significance.....	26
3.3 Possible Cultural Impact during the Construction Works.....	26
3.4 Significance Features.....	27
3.4.1 Assessment of Levels of Significances - Stone Steps.....	29
3.4.2 Assessment of Levels of Significances - Gas Lamps.....	31
3.4.3 Assessment of Levels of Significances - Storerooms underneath the Staircase.....	32
3.4.4 Assessment of Levels of Significances - Disused Tunnels....	34

3.4.5	Assessment of Levels of Significances - Wall Trees.....	36
4.	Heritage Impact Assessment and Mitigation Measures	
4.1	Context	37
4.2	Potential Impacts and Mitigation Measures on the Heritage Site	38
4.3	Potential Impacts on the Wall Trees	40
4.4	Potential Impacts on the Disused Tunnels Connecting Feature No. 11SW-B/R93	42
4.5	Potential Impacts on the Disused Tunnels Connecting Feature No. 11SW-B/R93	43
5.	Implementation	
5.1	Documentation	45
	Bibliography.....	45

Appendices

- Appendix A Slope Maintenance Responsibility Information System (SMRIS)
- Appendix B Site Location Plan and General Views of the Feature
- Appendix C Preliminary Designs
- Appendix D Sample of Similar Upgrading Works Feature
- Appendix E Aerial Photo Interpretation of the Feature
- Appendix F Repair Works at Duddell Street Stone Steps
- Appendix G Drawings of Disused Tunnels on Wyndham Street (Network No. 13)
- Appendix H Existing Utilities Information
- Appendix I Field Evaluation Photos
- Appendix J Part Plans and Photomontages of the Proposed U/I Works

1. INTRODUCTION

1.1 Background of the Project

This Heritage Impact Assessment (HIA) Report for the proposed slope Upgrading/ Improvement (U/I) works at Feature No. 11SW-B/R93 (sub-division 1), Duddell Street is submitted on behalf of Highways Department (HyD) in accordance with the requirements as stipulated in the Technical Circular (Works) No. 6/2009 – Heritage Impact Assessment Mechanism for Capital Works Projects, issued by Development Bureau, HKSAR Government on 18 September 2009.

Since 1 January 2008, Government projects which affect declared monuments, proposed monuments, sites and buildings graded by the Antiquities Advisory Board, recorded sites of archaeological interest and Government historic sites identified by the Antiquities and Monuments Office (AMO), except those specified, are required to conduct an HIA to assess impacts on historic/ heritage sites and buildings arising from the implementation of capital works projects so that their conservation will be given due consideration.

As identified under the Agreement No. CE32/2004(GE) for the Upgrading/ Improvement of Roadside Slope/ Retaining Walls on Hong Kong Island (2005 – 2008 Programme) – Investigation, Design and Construction, HyD has proposed to enhance the stability of an existing retaining wall located adjacent and behind a “declared monument” – Duddell Street Steps and Gas Lamps which is situated at the end of Duddell Street and between Nos. 20-22 Ice House Street, namely Feature No. 11SW-B/R93. The maintenance responsibilities of Feature No. 11SW-B/R93 are divided into 2 portions – sub-division 1 and sub-division 2 which are maintained by HyD and Lot No. IL339C,RP respectively. Sub-division 1 will be upgraded under this Agreement and Ove Arup & Partners Hong Kong Ltd (Arup) is responsible for the site investigation, detailed design and supervision of the construction works. A 1:1000 Slope Maintenance Responsibility Information System (SMRIS) Plan obtained from Lands Department showing the Feature location, maintenance responsibilities and lot boundaries is presented in Appendix A for reference.

The proposed U/I works involve backfilling the disused tunnels with rockfill material or the like, installation of soil nails, raking drains, construction of skin walls, installation of masonry facing and landscaping works for sub-division 1 of retaining wall Feature No. 11SW-B/R93 adjacent to the Duddell Street Steps and Gas Lamps. In accordance with memorandum reference LCS AM 53/6/21 dated 1 December 2009 addressed to the Chief Highway Engineer/ Works of HyD from the Director of Leisure and Cultural Services regarding the HIA Checklist, it is considered the heritage value of the Duddell Street Steps and Gas Lamps will be affected due to the proposed U/I works. Therefore, an HIA is required to identify all direct and indirect impacts during the construction

and operation periods to the heritage site and propose appropriate mitigation measures for AMO's comments.

Under the HIA process, Baseline Study, Impact Assessment and Mitigation Measures will be prepared. It is considered that Conservation Management Plan is not required as no construction works such as conversion works/ alternation works/ addition works/ demolition works will be implemented on any historic buildings/ sites in the "heritage sites" list.

Some photos showing the declared monuments adjacent to the Site are shown in Photo1.1 and 1.2 below:



Photo 1.1 – The Granite Stone Steps



Photo 1.2 – One of the Gas Lamps

1.2 Brief and Objectives of the Report

The HIA Report for the proposed U/I works at Feature No. 11SW-B/R93 (sub-division 1), Duddell Street has been prepared in order to identify any impacts and mitigation measures to the heritage site due to the proposed U/I works.

The principal objectives of the HIA are:

- To analyze, collect and collate extant information of the heritage site by desk-top searches and field evaluation.
- To identify possible direct and indirect impacts to the historic fabric of the Duddell Street Steps and Gas Lamps due to the proposed U/I works.
- To propose mitigation measures to alleviate adverse impacts to significant fabric.

1.3 Proposed Upgrading/ Improvement Works

In 2005, Arup was commissioned by the Works Division of HyD to carry out the Upgrading/ Improvement of Roadside Slopes/ Retaining Walls on Hong Kong Island under the Consultancy Agreement No. CE32/2004 (GE). Feature No. 11SW-B/R93 located at Duddell Street is one of the twenty-four features nominated by HyD.

The Site is bounded to the south-west by Ice House Street and to the north-east by Duddell Street, centered at Hong Kong Metric Grid reference 815 639N, 834 195E. The Feature is a masonry gravity wall, which retains the Ice House Street with very heavy traffic at a distance of 4m. The length of the Feature is 17m long and its height is 7m maximum with a front face angle of 85°. A granite stone staircase is adjoining to the middle portion of the study feature at Duddell Street to the north-east. Commercial buildings, Baskerville House and Hong Kong Diamond Exchange Building, are located immediately to the north-western and south-eastern ends of the Feature respectively. Disused tunnels (Network No. 13 – Wyndham Street) are located behind the Feature, with Portals 43 and 44 located at the north-western and south-western portions of the Feature, respectively. A 1:1000 Site Location Plan and general views of the Feature are presented in Appendix B.

In view of the close proximity of the retaining wall to Ice House Street along the crest and commercial buildings along the toe, the consequence-to-life in the event of a failure is considered to be in Category ‘1’ in accordance with Table 3 of Works Bureau Technical Circular (WBTC) No. 13/99. A preliminary stability checking of the Feature indicates that the stability of the wall against sliding and overturning does not satisfy the current geotechnical standards and slope improvement works are required.

Further to the comments on the design options given by GEO thru their memorandum reference GCI2/E1/11SW-B/R93 dated 16 August 2011 concerning the “structural integrity/ stability of the disused tunnels structure”, four revised design options for upgrading the Feature are listed below:

- Option 1 Construction of a 600mm thick reinforced concrete (RC) wall with stone facing in front of the existing Feature and backfill the disused tunnels by mass concrete acting as the footing of the RC wall.
- Option 2 Installation of soil nails of approximately 16m long at 1m c/c horizontal and vertical grid pattern and construction of a 250mm thick skin wall with stone facing 300mm in front of the existing Feature. The disused tunnels will be backfilling with rockfill material or the like and the existing gates to the disused tunnels will be re-constructed.
- Option 3 Installation of about 7 numbers of 18m long, 1.2m diameter bored pile wall with 1.8m c/c spacing along the crest of the feature. Access to the disused tunnels will be partially blocked.
- Option 4 Installation of soil nails of approximately 14m long at 1m c/c stagger pattern with recess soil nail heads. The original

masonry blocks will be replaced by masonry facings of similar colour.

Given consideration of the existing site environment, traffic conditions, construction cost, tree preservation feasibilities, possible impacts to declared monument (including vision impacts and nuisance to visitors), Option 2 is recommended as the proposed U/I works for the feature wall.

Option 1, 3 and 4 are not recommended for the proposed U/I works because of the following:

- Option 1: Construction of a RC wall (600mm thick) will visually cover half of the granite arches located at both sides of the Duddell Street Steps, which is not desirable. From the heritage preservation point of view, it is not recommended.
- Option 3: Installation of bored pile wall along the crest of the feature may have the least visual impact to the heritage site but the disturbance during construction to the Declared Monument will be larger while the brittle failure of the masonry wall may not be overcome. Also, the traffic condition of Ice House Street will be seriously affected. From the heritage preservation point of views, Option 3 is not recommended.
- Option 4: Installation of soil nails without skin wall is not a feasible design for existing masonry wall in accordance with GEO's comments. The brittle failure of the masonry wall cannot be solely overcome by soil nails.

Option 2 has due consideration to the costs and constraints of the site and is recommended as the preferred design option. Installation of soil nails is less sensitive to undetected adverse geological features, and thus more robust and reliable than other slope upgrading methods. After consulting the maintenance agent of the feature, HyD/Urban, all soil nails will be installed 4m below the existing ground level (Ice House Street) in order to minimize the damage of existing utilities including the gas pipes.

The main purpose of the proposed skin wall is to enhance the structural stability by connecting all the proposed soil nails together to form a complete structure and prevent the weak brittle failure of the existing masonry wall. The 300mm gap between the proposed skin wall and the existing Feature will be filled with aggregates for the existing tree roots. The proposed skin walls will be isolated from the sidewalls of the declared monument and covered by masonry facing which matches with the surrounding.

None of the fabric of the declared monument, including the stone steps and gas lamps will be disturbed during and after the proposed construction works. The existing accesses to the storerooms will not be blocked after the proposed U/I works. In addition, for structural stability reasons, backfilling the concerned discussed tunnels in reversible methods, such as

rockfill material or the like which can be removed from the tunnels by others if necessary, was also adopted in the design of Option 2. Comparison of the design options is presented in Appendix C for reference.

The existing wall trees located above Portal 43 and 44 will be closely monitored prior to and during the construction works by professional landscape architect. Tree protection such as covering the tree stems and roots by hessian bags will be carried out. In principal, if the trees conditions were good or fair, no tree felling or tree transplant will be carried out. Similar design was discussed with LCSD/AMO in 2005 and adopted for Feature No. 11SW-C/R307 at Bethanie, Pokfulam. Sample photos are attached in Appendix D for reference.

For security reasons and to bring the design into harmony, new steel gates with stone facing matching the surrounding atmosphere will be provided and installed in front of the portals after the works.

1.4 Methodology

The assessment of impacts and proposal of mitigation measures in this report shall refer to the Environmental Impact Assessment Ordinance (Cap.499) and Guidelines for Built Heritage Impact Assessment (BHIA) as at 16 May 2008.

Since possible impacts to the heritage site and historic fabric are anticipated during the implementation of the proposed U/I works, an HIA Report including the following will be prepared:

1.4.1 Baseline Study

The baseline study shall identify the direct and indirect impacts on the heritage sites at the planning stage in order to avoid causing any negative effects to the declared monuments. The impacts include the direct loss, destruction or disturbance of any element of cultural heritage, impact on its settings or impinging on its character through inappropriate siting or design, potential damage to the physical fabric of historic structure or historic landscapes through air pollution, change of ground water level, vibration, ecological damage, new recreation or other daily needs to be caused by the proposed U/I works. The baseline study shall include a desk-top researches and a field evaluation.

1.4.2 Impact Assessment

Cultural heritage impact assessment must be undertaken to identify the impacts, both direct and indirect, on the sites of cultural heritage by the proposed U/I works based on the results of desk-top researches and field evaluation. Detailed description and plans shall be provided to elaborate to what extent the sites of cultural heritage will be affected.

All impacts arising due to the proposed U/I works shall include but not limited to the following:

- Impacts on the declared monuments – Stone steps and gas lamps;
- Impacts on the disused tunnels connecting Feature No. 11SW-B/R93;
- Impacts on the adjacent buildings in the vicinity of the heritage site;
- Impacts on the adjacent footpath/ pavement;
- Impacts on all underground utilities constructed in the vicinity of the heritage site; and
- Impacts on the wall trees located on Feature No. 11SW-B/R93.

Although the storerooms located underneath the Duddell Street Stone Steps form part of the declared monuments, the proposed U/I works shall not imposed any adverse effect to the stability of the storerooms due to their far distance from the works area. However, monitoring works for the storerooms will be carried out throughout the construction period. Details of the monitoring works are shown in Section 2.2.1.6.

The evaluation of HIA will be classified into five levels of significance based on the type and extent of effects concluded in the HIA study – “Beneficial Impact”, “Acceptable Impact”, “Acceptable Impaction with Mitigation Measures”, “Unacceptable Impact” and “Undetermined Impact”. These impacts will be identified according to the preliminary designs of the proposed U/I works.

1.4.3 Mitigation Measures

Mitigation measures will give priority to avoidance of impacts. Mitigation measures will be proposed to avoid, reduce and remedy the adverse impacts previously identified. The overall effects after application of mitigation measures will be assessed with four levels of impact, from “High”, “Medium”, “Low” to “Neutral”.

Mitigation is not concerned with minimizing adverse impact on the heritage site but shall also give consideration of potential enhancement if possible (such as to improve the access to the heritage site or enhance the landscape and visual quality of the declared monuments).

1.5 Definitions

The following definitions of terms will be referred to in this HIA Report:

Site refers to the piece of land where the proposed U/I works will be carried out. The area is shown edged black on Figure 1.1.

Feature refers to the retaining wall No. 11SW-B/R93 as shown in the SMRIS plan.

Declared Monuments refer to the Duddell Street Steps and Gas Lamps located at Duddell Street, between Nos. 20 and 22 of Ice House Street. It is hatched on Figure 1.2.

The following definitions have been reproduced from the *Australia ICOMOS Charter for the Conservation of Places of Cultural Significance (the Burra Charter)* as follows:

Place means site, area, land, landscape, building or other work, group of buildings or other works, and may include components, contents, spaces and views.

Cultural significance means aesthetic, historic, scientific or social value for past, present or future generations.

Fabric means all the physical material of the *place*, including components, fixtures, contents, and objects.

Conservation means all the processes of looking after a *place* so as to retain its *cultural significance*.

Maintenance means the continuous protective care of the *fabric* and *setting* of a *place*, and is to be distinguished from repair. Repair involves *restoration* or *reconstruction*.

Preservation means maintaining the *fabric* of a *place* in its existing state and retarding deterioration.

Restoration means returning the existing *fabric* of a *place* to a known earlier state by removing accretions or by reassembling existing components without the introduction of new material.

Reconstruction means returning a *place* to a known earlier state and is distinguished from *restoration* by the introduction of materials [new or old] into the *fabric*.

Adaptation means modifying a *place* to suit the existing *use* or a proposed use.

Use means the functions of a *place*, as well as the activities and practices that may occur at the *place*.

Compatible use means a *use* which respects the *cultural significance* of the *place*. Such a *use* involves no, or minimal, impact on cultural significance.

Setting means the area around a *place*, which may include the visual catchment.

Associations mean the special connections that exist between people and a *place*.

Interpretation means all the ways of presenting the *cultural significance* of a *place*.

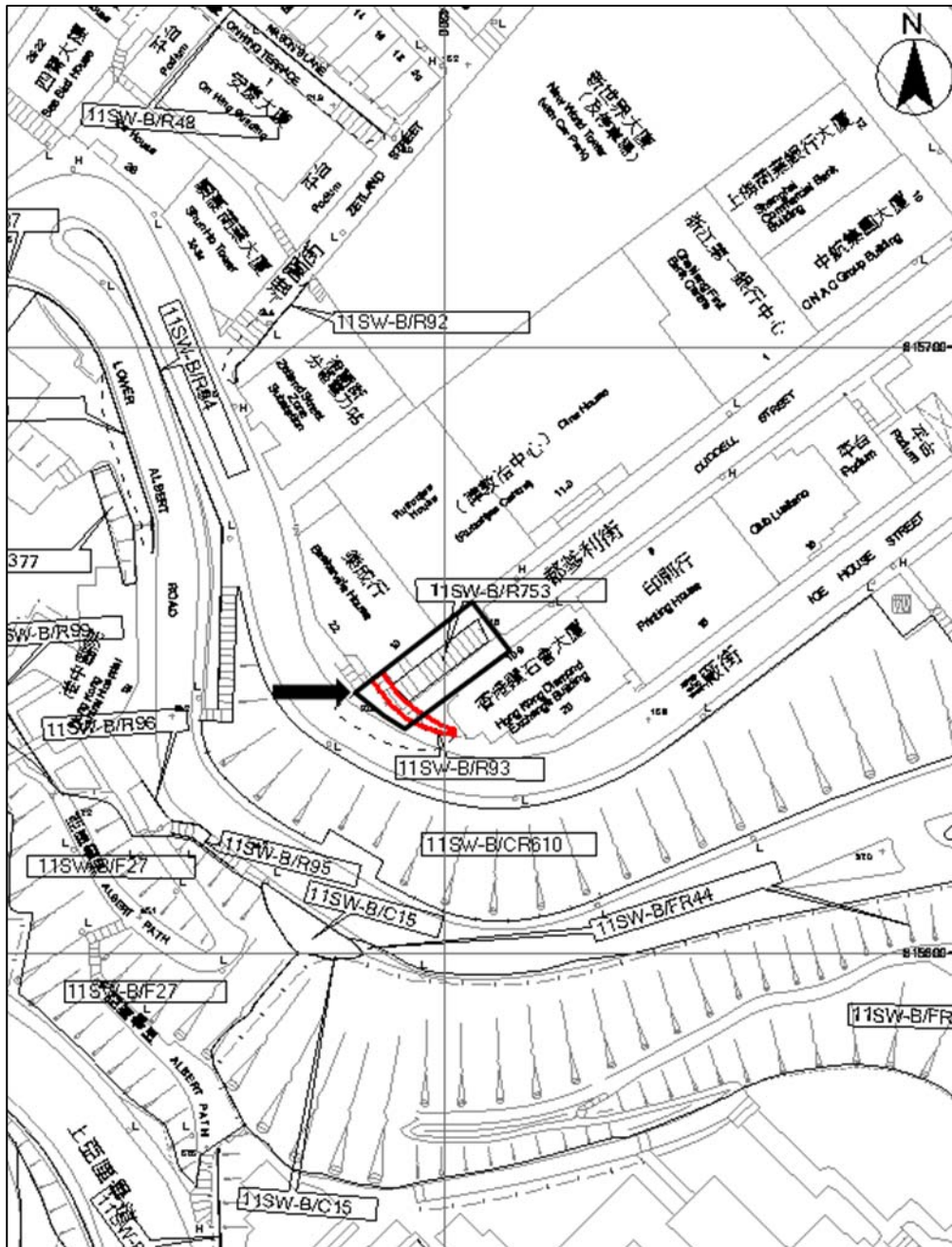

Plate 1.1 – 1:1,000 Site Plan of Proposed U/I works at Feature No. 11SW-B/R93 (Sub-division 1)

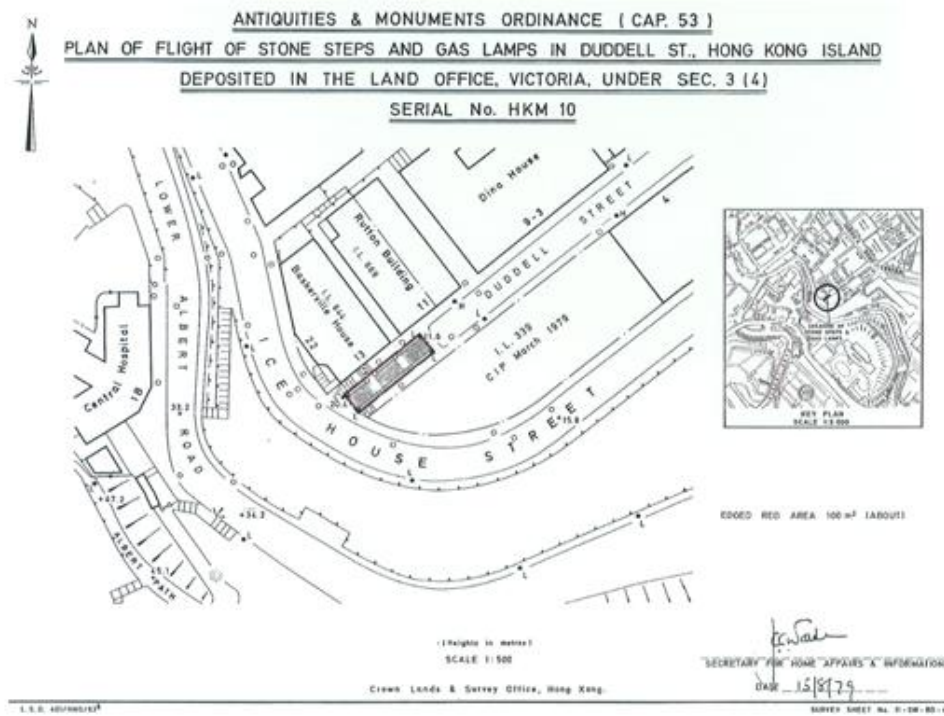

Figure 1.2 – Site Plan of the Declared Monuments – Duddell Street Steps and Gas Lamps (obtained from AMO)

2. BASELINE STUDY

2.1 Desk-top Researches

This HIA Report has been commissioned by HyD and prepared by Arup to identify all direct and indirect impacts to the declared monuments and any heritage sites in the vicinity of the Site during and after the proposed U/I works. After the proposed U/I works, the stability of the existing retaining wall, Feature No. 11SW-B/R93 sub-division 1, located behind and adjacent to the Duddell Street Steps, will be enhanced to meet the current geotechnical standard. The desk-top researches will be conducted to identify and compile a comprehensive inventory of the heritage site including the history, the maintenance responsibilities of the declared monuments, information of the adjacent structures, vegetation and underground utilities.

2.1.1 History of the Duddell Street Steps and Gas Lamps

The Duddell Street Stone Steps were named after George Duddell, an auctioneer and ultimately a significant property owner in the area around the present Duddell Street in mid-19th century. A portrait of George Duddell is shown in Photo 2.1. It has not been possible to establish precisely when the Stone Steps were built but it is estimated that the stone steps at Duddell Street were built between 1875 and 1889. Serial maps of old Hong Kong indicate that the Stone Steps were existed as early as 1875. In 1883 the Stone Steps were reconstructed at a cost of HK\$ 1,750. Aerial photo interpretation of the Feature is presented in Appendix E for reference.



Photo 2.1 – A Portrait of George Duddell

Four gas lamps surmounting the balustrades at the top and foot of the steps are the only surviving working gas street lamps in Hong Kong. The lamp posts, described as two-light Rochester models, were made by Suggs and Co. with shortened length so that they could be installed on the parapets of the steps. It is uncertain when the lamp posts were installed, although this model appeared in Suggs catalogue of 1922. Photos of the gas lamps are shown below.



Photo 2.2 – The existing gas lamps surmounting at the crest and toe of the stone steps

The records of the Hong Kong and China Gas Company showed that the lamps were re-lit after World War II on 29 February 1948. Of the more than two thousand gas lamps which once lit Hong Kong's Streets, over a dozen were still being used in the early 1950s. In the 20 years followed, most of Hong Kong's gas lamps were gradually replaced by electricity lamps, and by September 1967 the gas company's records showed only the four Duddell Street gas lamps remaining.

The Hong Kong and China Gas Company which was originally founded to provide street lighting in Hong Kong retained these gas lamps and continued operating them between 6:00pm and 6:00am as objects of historical interest. The Duddell Street Steps and Gas Lamps are declared as monuments of Hong Kong in 1979.

The Hong Kong Government has once proposed to conserve these 4 gas lamps in the Hong Kong Museum of History. However, for the historical interest, these gas lamps were retained at their original locations and maintained by the Hong Kong and China Gas Company. The existing gas mantle and lightshade were ordered from England and installed by the Urban Council of Hong Kong Government in 1984.

2.1.2 Maintenance Responsibilities of the Declared Monuments

HyD have been maintaining the flight of granite stone steps together with the four gas lamps as normal street furnitures before they were declared as monument on 15 August 1979 under the Antiquities and Monuments Ordinance (Cap.53). According to the records, after the declaration, the stone steps and the four gas lamps became maintained by Architectural Services Department (ArchSD), as the maintenance agent of Antiquities and Monument Section of Leisure and Cultural Services Department (LCSD) (AMO) with funding provided by HyD. In financial years 1984/85 and 1985/86, the Urban Council spent \$72,479.70 restoring the declared monument with spare parts such as globes, mantles and nozzles imported from Britain. In mid 2008, one of the gas lamps together with the box newel located at the upper end of the Stone Steps at Ice House Street was found tilting significantly as shown in Photo 2.3 below.

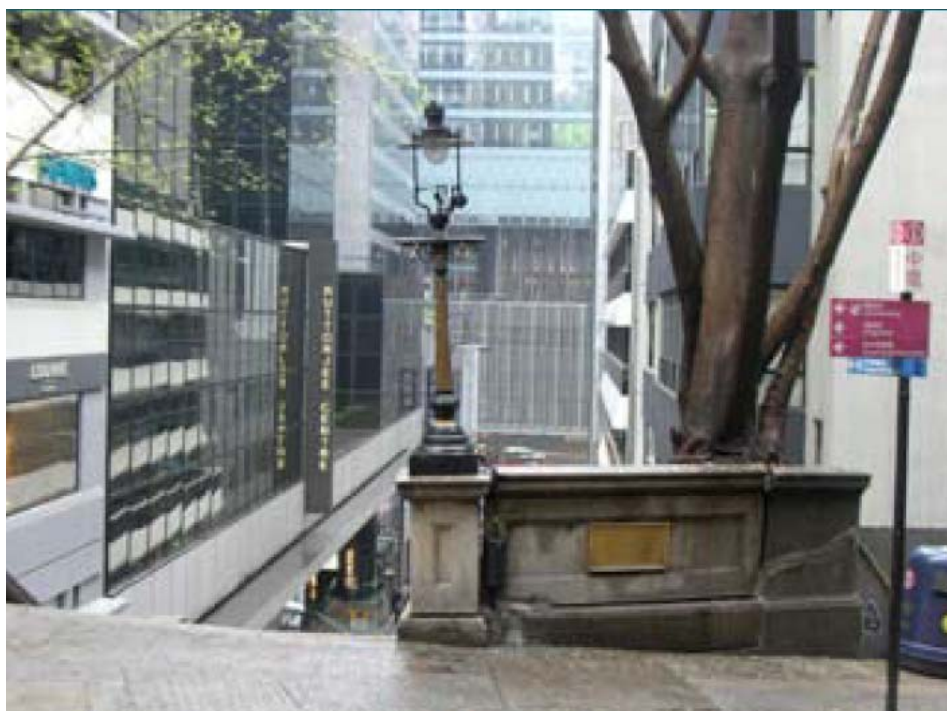

Photo 2.3 – One of the gas lamps was found tilting at Ice House Street

Subsequently, HyD took up the maintenance of the four gas lamps and the stone steps and carry out urgent repair to the tilted gas lamp and the supporting box newel. According to the record, after HyD took up the maintenance responsibilities, the only maintenance works were commenced on July 2009 undertaken by a specialist contractor on the Works Bureau’s approved list of “Repair and Restoration of Historic Building Category” to ensure the quality of works. No other alternation/major repair works were observed which may affect the authenticity of the declared monument throughout the years. Some photos showing the maintenance works are attached below in Photos 2.4 and 2.5. HyD’s Newsletter Issue 3/2009 including the background and procedures of repair works for the declared monuments in 2009 and the Works Order for

repair works by Urban Council from 1984 to 1986 are attached in Appendix F for easy reference.



Photo 2.4 – Damaged portion previously patched with cement mortar

Photo 2.5 – Damaged portion after repairing by specialist contractor

2.1.3 Investigation on Disused Tunnels

In accordance with the Report for Investigation of Disused Tunnels on Wyndham Street (Network No. 13) prepared by Mott, Hay & Anderson Far East under Agreement No. CE 11/77 in 1982, full inspection, documentation, survey, site investigation and geotechnical studies of the Wyndham Street network together with studies concerning the influence of the tunnels on adjacent slopes and structure were carried out.

The report stated that the Wyndham Street tunnel network is situated beneath and to the south of Ice House Street, Central and lies beneath Central Hospital, the Hong Kong Juvenile Care Centre (today named as Hong Kong Sheng Kung Hui Welfare Council) and junction of Lower Albert Road with Wyndham Street. A plan is shown on Drawing No. A1/101/13/201 – “General Layout” which is included in Appendix G of this report. The report indicates that two short discrete tunnels (approximately 10m) running under Ice House Street in a perpendicular direction from Portals 43 and 44 in Duddell Street are connected to the Wyndham Street tunnel network. The entries of these two tunnels (Portals 43 and 44) are located on the left and right sides of the Duddell Street Steps and Gas Lamps. A plan showing the portals is attached in Figure 2.1 below.

In 1959 a partial road collapse occurred above the tunnel at the junction of Lower Albert Road and Ice House Street. The records indicate that a section of 200 feet length of tunnel was backfilled in 1960. It is presumed, in the report that, this was the length from Junction 4 to the ventilation shaft. This backfilling are necessitated for the construction of the two bulkheads at the ends of the accessible tunnels – the short tunnels adjacent to the Duddell Street Steps and Gas Lamps. These portions of the tunnels

connecting Portal 43 and 44 have remained empty till today. The location of Junction 4, ventilation shaft and the portion of the backfilled tunnel can be seen in Drawing No. AO/101/13/203 included in Appendix G of this report.

At the same time, the original construction of the tunnel has been modified by addition of an inner granite masonry sidewall and by the replacement of the arch lintels with flat precast reinforced concrete lintel in order to enhance the stability of the tunnel. In accordance with the report, it is presumed that the modification was carried out between 1954 and 1955 where many Air Raid Precaution (ARP) tunnels were repaired under roof lintel replacement programme.

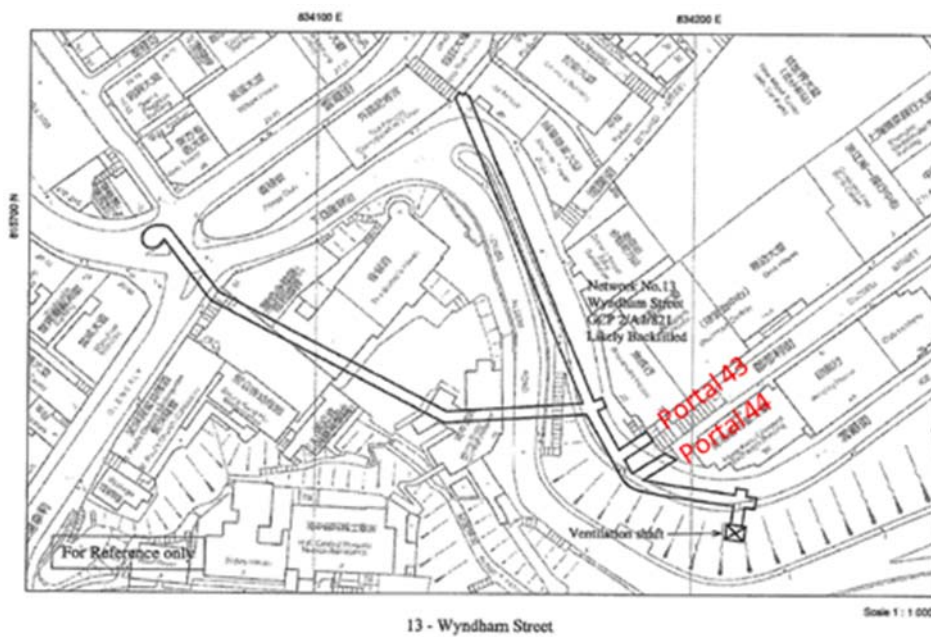

Figure 2.1 – Wyndham Street Tunnel Network

Portal 43 is located at the northern side of the Site while Portal 44 is located at the southern side. Referring to the report during the inspection by Mott, Hay & Anderson Far East in 1982, the tunnel lining for the sections connecting Portals 43 and 44 are in fair and good condition respectively. In both tunnels, the granite masonry sidewalls are in good condition.

However, the report recommended that because of the poor condition of the Wyndham Street tunnel network and the threat it poses to the overlying structures, the network shall be backfilled. It is also recommended that the backfilling to the tunnels shall make provision to maintain the drainage aspects of the network.

Detailed inspection reports of the disused tunnel networks can be found at Geotechnical Information Unit and Geotechnical Engineering Office of Civil and Engineering and Development Department.

2.1.4 Vegetation in the Vicinity of the Heritage Site

The Task Force on Tree Management led by the Chief Secretary for Administration published a report entitled “People, Trees, Harmony” in June 2009. Pursuant to the recommendations of the report, the Development Bureau in conjunction with the Tree Management Office (TMO) implemented the Tree Risk Assessment Arrangements in January 2010 to better protect public safety.

The Development Bureau appreciates the public concern about tree safety. To further protect public safety and to facilitate community-wide surveillance, the Development Bureau has uploaded to its tree website information on trees which have undergone detailed inspections by TMO in recent months but the improvement measures for which have not yet been completed as well as trees requiring special attention (e.g. Old and Valuable Trees and stonewall trees).

In the website, it is noted that two existing wall trees, i.e. *Ficus virens* var. *sublanceolata* located at Feature No. 11SW-B/R93 required special attention. However, no significant defects were observed on these trees during the inspection by HyD on 7 April 2010.

2.1.5 Existing Utilities

Based on the information provided by Water Supplies Department (WSD), a 6” and a 4” fresh water main is located at the crest of the south-western and north-western portions of the Feature, respectively. According to the information provided by Drainage Services Department (DSD), there is no sewer pipe on the Feature. Summary of information provided by other utilities companies are listed below:

Company Name	Response
The Hong Kong Electric Co. Ltd.	4 11kV reserved cable routes, 4 low voltage cable routes, 14 fibre optic/pilot cable routes, 2 proposed cables are located in the western portion of the Feature
Hong Kong & China Gas Co. Ltd.	20V and 25V gas pipes are located at the crest and both eastern and western portions of the Feature.
New World Telephone Co. Ltd.	No Services
Wharf T & T HK Ltd.	No Services
Hutchison Global Crossing Ltd.	No Services
PCCW HKT Telephone Ltd.	A joint box and duct are located at the crest of the Feature
New World Telephone Co. Ltd.	No Services

Company Name	Response
Hong Kong Cable Television Ltd.	An existing duct with a jointing chamber located at the crest of the Feature.

Copies of referral letters are attached in Appendix H for reference.

2.2 Field Evaluation

This section is to focus on appraisal of the physical conditions of the adjacent declared monument, existing disused tunnels, adjacent buildings, footpath or pavement, existing utilities on the wall and existing trees and evaluating the possible impacts caused due to the proposed U/I works. Except the disused tunnels, site inspections were carried out on 4 January 2011 and photos taken are attached in Appendix I. Proposed mitigation measures on these elements will be discussed in Section 3 below.

2.2.1 Field Evaluation on the Declared Monuments

Inspections of the physical condition of the declared monuments were carried out on fabrics such as parapet wall, granite stone staircase, granite stone handrailing, gas lamps, masonry facing and the storerooms underneath the staircase.

2.2.1.1 *Parapet Walls*

The parapet wall is considered to be part of the declared monuments and is located at the crest of Feature No. 11SW-B/R93, along Ice House Street. The dimension of the walls at the north-western and south-western sides of the Feature are 2.70m (L) x 0.40m (W) x 0.75m (H) and 3.70m (L) x 0.40m (W) x 1.40m (H) respectively.

At the north-western side of the Feature, the parapet wall is connected to an existing concrete wall by cement mortar at the north, a box newel that supports the gas lamp at the south, the pavement of Ice House Street at the west and Feature No. 11SW-B/R93 at the east (please refers to Plate 2 in Appendix B). An existing wall tree is growing above the Feature adjacent to the parapet wall. No tree roots are observed causing damage to the parapet wall at this moment.

At the south-western side of the Feature, the parapet wall is connected by cement mortar to an existing concrete wall covered by mosaic tiles at the south, a box newel that supports the gas lamp at the north, the pavement of Ice House Street at the west and Feature No. 11SW-B/R93 at the east (please refers to Plate 3 in Appendix B). Significant gaps of approximately 40mm between the parapet wall to the wall base and to the

box newel are observed during the inspection. The gaps are anticipated to be formed due to the extension of tree roots from an existing wall tree growing above the Feature adjacent to the parapet wall.

During the construction stage, the vibration generated by the soil nailing works and concreting works will be minimized and the potential impacts due to the proposed U/I works to the parapet wall are considered to be insignificant. Vibration assessment, noise assessment and ground settlement will be carried out in adequate intervals to ensure the conditions of the parapet walls are not adversely affected by the proposed U/I works.

2.2.1.2 *Granite Stone Staircase*

The granite stone staircase is considered to be part of the declared monuments and is located between Ice House Street and Duddell Street. It is situated in the middle of Feature No. 11SW-B/R93. The staircase is separated into three sections by two landings, the upper, the middle and the bottom sections. In the upper section, 19 treads with a total inclined length of 6.20m are measured during the site inspection. For the middle and bottom sections, total of 18 and 19 treads with inclined length of 5.85m and 6.20m were measured during the site inspection respectively. Total of 56 treads forming this declared monument (please refer to Plate 4 in Appendix B).

The treads are generally formed by 2 types of different sized stones – A) 1.80m (L) x 0.30m (W) x 0.15m (H) and B) 1.20m (L) x 0.30m (W) x 0.15m (H), repeated in a pattern of 2A and 3B. These granite stones are connected by cement mortar in fair condition. Some obvious remedial works were observed on the surface of these treads by other parties. The two landings, which separate the upper, middle and bottom section of the staircase, are approximately 3.60m (L) x 1.85m (W). The pattern showing two “X” are observed in fair condition.

During the construction stage, the vibration generated by the soil nailing works and concreting works will be minimized and the potential impacts due to the proposed U/I works to the granite stone staircase are considered to be insignificant. Vibration assessment, noise assessment and ground settlement will be carried out in adequate intervals to ensure the conditions of the granite stone staircase are not adversely affected by the proposed U/I works.

2.2.1.3 *Granite Stone Handrailings*

The granite stone staircase enclosed by granite stone handrailings at the northern and southern sides is considered to be part of the declared monuments. The granite stone handrailings are connected to the staircase and separated into three sections similar to the treads – the upper, the middle and the bottom sections. For the upper and bottom sections, the handrailings are connected to the box newels supporting the gas lamps at

one end and box newels on the landings at the other end. For the middle section, the handrailings are connected to the box newels on the landings at both ends.

All the granite stone handrailings are supported by balusters of approximately 0.6m tall in lanterns shape. For the southern portion, 16, 17 and 16 balusters are found at the upper, middle and bottom sections of handrailings respectively. Total of 4 balusters are found between the box newels at the landing sections. The entire handrailings are connected by box newels. For the northern portion, 15, 15 and 16 balusters are found at the upper, middle and bottom sections of handrailings respectively. Total of 2 balusters are found between the box newels at the lower landing section. However, the northern portion of granite stone handrailings is discontinued at the upper landing for 1.50m. A small section of staircase is constructed at this opening and is connected to the adjacent building (Baskerville House) (please refers to Plate 5 in Appendix B).

During the construction stage, the vibration generated by the soil nailing works and concreting works will be minimized. The existing joints between each granite stone handrailing located near to the site will be monitored closely to ensure that no adverse effect due to the proposed U/I works will be occurred. All construction materials will be mobilized from Duddell Street in order to prevent any damage to the granite stone staircase. Vibration assessment, noise assessment and tell-tale monitoring will be carried out in adequate intervals to ensure the conditions of the granite stone handrailings are not adversely affected by the proposed U/I works.

2.2.1.4 Gas Lamp

The four gas lamps located above the box newels are considered to be part of the declared monuments – two located at Ice House Street and two located at Duddell Street. Each gas lamp post is described as two-light Rochester models with a height of approximately 2.50m, connected to a gas pipe maintained by The Hong Kong and China Gas Company. Except the strips on the lamp post in gold colour and the interior of the lampshade in white colour, the lamp is mainly in black colour. During the inspection, the gas lamps are functioning and in good condition (please refers to Plate 6 in Appendix B).

During the construction stage, the vibration and dust generated by the soil nailing works and concreting works will be minimized. The condition of each gas lamp and the connected gas pipes will be closely monitored. All construction materials will be mobilized from Duddell Street by manpower in order to prevent any damage caused by lifting apparatus to the gas lamps. Vibration assessment, noise assessment and ground settlement monitoring will be carried out in adequate intervals to ensure the conditions of the gas lamps are not adversely affected by the proposed U/I works.

2.2.1.5 Granite Masonry Blocks

The granite masonry blocks installed on the sidewalls of the staircase are considered to be part of the declared monuments. It is considered that the walls are mainly constructed by granite blocks of size 0.30m x 1.70m x 0.30m in a staggered pattern. The existing physical conditions of the granite masonry blocks are good without obvious cracks (please refer to Plates 7 & 8 in Appendix B).

During the construction stage, the vibration generated by the soil nailing works and concreting works will be minimized. The conditions of the masonry blocks will be closely monitored during the works to ensure that no adverse effect, such as cracking, due to the proposed U/I works will be occurred. If necessary, the wall surface will be protected by polyfoam board during the transportation of construction materials.

2.2.1.6 Storerooms underneath the Staircase

The two storerooms located underneath the staircase are considered to be part of the declared monuments. The storerooms are locked and the keys are kept by Food and Environmental Hygiene Department (FEHD). One of the storerooms is located near the Feature with a granite arch lintel above a wooden door, while the other storeroom is located near Duddell Street locked by a rectangular steel gate. Both storerooms were inspected during the ground investigation stage on 27 November and 7 December 2007.

The interior of the storeroom with an arch lintel is painted yellow, rectangular in shape with a concrete floor of approximately 3.0m x 2.0m in size. The arch ceiling is in white colour with a fluorescent light installed in the middle. Some electric switch boxes are installed on the eastern wall behind the wooden door. During the inspection, none of the electricity apparatus are checked and their conditions are unknown. Except some ceiling plaster being peeled off near the western side, the storeroom is generally in good condition. During the inspection, some old furnitures such as steel cupboard, wooden chairs, bicycle and trolley are found inside the storeroom. Some traces of screw holes and core holes are left on the surface of the eastern and western walls inside the storeroom and on the concrete floor. It is believed that some previous core holes are carried out on these walls and floor during the ground investigation works. For the exterior, the storeroom is decorated by a pink granite arch with black wooden door and transparent glass windows at the southern side. The conditions of the door and glass are fair. A brick transom window with steel frame of size 0.35m (H) x 0.80m (W) is located 1.75m above ground at the northern side of the storeroom. The steel frame is corroded and in poor condition. The brick wall below the granite arch lintel is rigid with no cracks observed during the inspection (please refer to Plate 9 in Appendix B).

The second storeroom with a rectangular steel gate is similar in size and

shape as the first storeroom. Three beams are constructed in the ceiling and coloured in white with a florescent light installed in the middle. During the inspection, none of the electricity apparatus are checked and their conditions are unknown. The storeroom is fully stockpiled with miscellaneous items such as trolleys, cupboards and steel frames etc. Since the storeroom is fully occupied, the existing condition of the storeroom including the walls and the floor could not be inspected. A steel gate with a height of 2.15m and width of 1.07m is black in colour and in fair condition (please refers to Plate 10 in Appendix B).

Prior to the commencement of the proposed U/I works, FEHD will be requested to empty the storerooms for field evaluation and the conditions of both the interior and exterior of the storerooms will be recorded. During the construction stage, the vibration generated by the soil nailing works and concreting works will be minimized. The conditions of the exterior of the storerooms will be checked during the works to ensure that no adverse effect, such as damage of doors or windows, due to the proposed U/I works will be occurred. The wooden doors and windows will be protected by polyfoam board during the works.

2.2.2 Field Evaluation on the Existing Disused Tunnels

Two disused tunnels with portals namely Portal 43 and Portal 44 are located below the Feature (for details, please refer to Section 2.1.3). The maintenance responsibilities of these tunnels and the gates outside the portals are belongs to Civil Engineering and Development Department and Highways Department respectively.

For Portal 43 located at the northern side of the Feature, site inspection was carried out on 21 December 2007 during the ground investigation stage. The portal is constructed under a concrete counterfort enclosed by a brick wall and a grey colour steel gate of approximately 2.07m (H) x 1.00m (W). At the bottom right corner of the gate, an opening of approximately 0.36m (H) x 0.31m (W) is reserved for a 0.17m diameter PVC water pipe extended from the tunnels to a box channel. Behind the portal, the tunnel is rectangular in shape with masonry sidewalls and rows of flat precast reinforced concrete lintels at the ceiling. The tunnel is approximately 1.56m wide, 2.10m high and 9.85m deep (please refers to Plate 11 in Appendix B).

During the inspection, minor seepage was observed at the masonry sidewalls inside the tunnel but the conditions of the sidewalls were considered fair. Some corrosion at the reinforcement inside the flat precast reinforced concrete lintels was also observed. A 0.17m diameter PVC water pipe was extended from the end of the tunnel to Portal 43 and connected to a box channel. At the end of the tunnel, a wooden ladder left by somebody was leaned against the back wall of the tunnel. At the top of the back wall, a hole of approximately 1.00m x 0.30m was observed.

Behind the back wall, the tunnel was backfilled by large amount of boulders and cement.

Site inspection for Portal 43 was carried out again on 12 November 2010. Unfortunately, a tree root of approximately 0.08m diameter was found blocking the access to the disused tunnel. Photos were only taken at the entrance of the portal. It is observed that some tree roots were growing from the entrance toward the back of the tunnel along the masonry sidewalls, floor and ceiling.

For Portal 44 located at the southern side of the feature, site inspection was carried out on 8 May 2010. The portal was constructed under a concrete counterfort enclosed by a brick wall and some corrugated steel plates. Some tree roots were winding around and blocked the entrance of the portal. Behind the corrugated steel plates, a seriously corroded steel gate was found. The condition of the steel gate was considered very poor. Since the gate could not be opened due to its poor condition, photos of the tunnel were only taken at the portal entrance. The tunnel behind Portal 44 is very similar to the tunnel behind Portal 43, generally rectangular in shape with masonry sidewalls and rows of flat precast reinforced concrete lintels at the ceiling.

Since the tunnel at Portal 44 is very dark, the condition of the masonry sidewalls and the ceiling is unknown. However, it is observed that a lot of empty glass bottles were placed on the floor. The purposes of these bottles are unknown. Seepage was observed on the masonry sidewalls inside the tunnel and at the portal entrance. It is also observed that some tree roots were growing from the entrance toward the back of the tunnel along the masonry sidewalls, floor and ceiling (please refers to Plate 12 in Appendix B).

Prior to the commencement of the proposed U/I works, HyD will be requested to open the steel gate at Portal 43 & 44 for field evaluation and the conditions of the tunnels will be recorded. During the construction stage, two rows of soil nails will be installed above these disused tunnels below Ice House Street. The vibration generated by the soil nailing works and concreting works will be minimized. Since access to these tunnels is not possible and monitoring on these tunnels during the construction stage become difficult. Approval of removing all the steel gates and corrugated steel plates may be required during the construction in order to provide adequate monitoring. Vibration assessment and ground settlement monitoring will be carried out in adequate intervals to ensure the conditions of the disused tunnels are not adversely affected by the proposed U/I works.

2.2.3 Field Evaluation on the Adjacent Buildings

Feature No. 11SW-B/R93 is located between Ice House Street and Duddell Street at the south-western and north-eastern sides respectively. At the northern side of the feature, Baskerville House is located 2.68m from the sidewall of the granite stone staircase. At the southern side of the feature, Hong Kong Diamond Exchange Building is located 2.30m away from the staircase.

Baskerville House is connected to the northern side of the Feature. The gap between the building and the feature is covered by a brick wall with some utilities behind. The building is in good condition but the brick wall is in poor condition due to the growth of tree roots. Two numbers of air conditioners and some water pipes were mounted on the exterior of Baskerville House. Approximately 2.0m away from Portal 43, a trapezoid steel gate was constructed by some parties connected between the granite stone staircase and Baskerville House. During the site inspection, the gate locked by the management company of Baskerville House was acting as an advertisement board facing Duddell Street. At the back of the gate, some corrosion was observed. The gate is green in colour and in fair condition. No obvious damage was observed on the exterior of Baskerville House during the site inspection.

Hong Kong Diamond Exchange Building is connected to the southern side of Feature No. 11SW-B/R93 sub-division 2. The condition of the building is good and no obvious damage was observed on the exterior of the building during the site inspection.

During the construction stage, the vibration and dust generated by the soil nailing works and concreting works will be minimized and the potential impacts due to the proposed U/I works to the adjacent buildings are considered to be insignificant. Vibration assessment and building settlement monitoring will be carried out in adequate intervals to ensure the conditions of the adjacent buildings are not adversely affected by the proposed U/I works.

2.2.4 Field Evaluation on nearby Footpath/ Pavement

The southern side of Duddell Street is numbered even from No. 6 to 10 while the northern side is numbered odd from No. 1 to 13. At the northern side of Duddell Street adjacent to Baskerville House, the condition of the pavement is in good. No obvious cracks were observed on the pavement. At approximately 1.25m in front of the advertisement board, a 2.68m width trend covered by masonry tiles constructed by some parties was observed. At the southern side of Duddell Street adjacent to Hong Kong Diamond Exchange Building, the condition of the pavement is in good. No obvious cracks were observed on the pavement.

During the construction stage, the vibration and dust generated by the soil nailing works and concreting works will be minimized and the potential impacts due to the proposed U/I works to the adjacent footpath/ pavement are considered to be insignificant. Ground Settlement monitoring will be carried out in adequate intervals to ensure the conditions of the footpath/ pavement are not adversely affected by the proposed U/I works. If necessary, the footpath/ pavement will be covered by planks during the works in order to prevent any damage caused by the works.

2.2.5 Field Evaluation on Existing Utilities on the Feature

At both the northern and southern sides of the feature, some existing utilities were installed on the wall surfaces including fresh water pipes, salt water pipes, electricity cables, gas pipes and telecommunication cables etc.

At the northern side of the feature, some utilities were installed on both the Feature and exterior of Baskerville House. These include a red 0.12m diameter fresh water pipe, a black 0.10m diameter gas pipe, a black 0.05m diameter water pipe, a red 0.08m diameter and two diameter 0.02m diameter telecommunication cables. All these utilities were extended to the toe of the feature and connected to other apparatus such as fire hydrant and salt water pipes. Except the two damaged electricity cables, the conditions of the abovementioned utilities are unknown and further investigation by specialists shall be required prior to the commencement of the proposed U/I works.

At the southern side of the Feature, some utilities were installed on the feature which includes a black 0.16m diameter water pipe and a grey 0.03m diameter PVC pipe. All these utilities were extended to the toe of the feature. The conditions of the abovementioned utilities are unknown and further investigation by specialists shall be required prior to the commencement of the proposed U/I works.

During the construction stage, the vibration generated by the soil nailing works and concreting works will be minimized and the potential impacts due to the proposed U/I works to the existing utilities will be assessed after detailed investigation by specialists were carried out. If necessary, diversion of some of the existing utilities may be required before the proposed U/I works. Precaution measures will be provided to detect or to protect these utilities during the works.

2.2.6 Field Evaluation on Existing Trees

Two existing walls trees namely *Ficus virens* var. *sublanceolata* are grown on the crest of the Feature adjacent to the declared monument. In accordance with the tree risk assessment information extracted from the TMO, no significant defects were observed on these trees during the

inspection on January 2010 (details of the tree assessment may retrieved from the following links: [http://www.trees.gov.hk/en/doc/Central%20and%20Western%20\(English\).pdf](http://www.trees.gov.hk/en/doc/Central%20and%20Western%20(English).pdf) or [http://www.trees.gov.hk/tc/doc/Central%20and%20Western%20\(Chinese\).pdf](http://www.trees.gov.hk/tc/doc/Central%20and%20Western%20(Chinese).pdf)).

At the north-western side of the Feature, the wall tree is maturely growth with a overall height of approximately 12m. The diameter at the breast height of the tree is approximately 0.55m and the average crown spread is 5.00m. The current condition and form of the wall tree is fair but the possibility of survival if being transplanted is low. The tree roots were growing in all direction from the crest of the Feature. The main tree root is growing downwards to the Feature toe towards to the disused tunnel. Some tree roots are growing towards the southern end of the Feature. Part of the parapet wall at the wall crest was damaged by the tree roots.

At the southern side of the Feature, the wall tree is maturely growth with an overall height of approximately 10m. The diameter at the breast height of the tree is approximately 0.25m and the average crown spread is 3.00m. The current condition and form of the wall tree is fair but the possibility of survival if being transplanted is low. The tree roots were mainly growing downwards from the crest of the Feature towards to the disused tunnel at the toe. One of the tree roots is blocking the access to Portal 43 (see Section 2.2.2 for details).

During the construction stage, the vibration and dust generated by the soil nailing works and concreting works will be minimized. No direct contact of cement grout or concrete will be allowed to the tree stems or tree roots during and after the construction works. In order to protect the trees from damage, tree stems and roots on the surface of the Feature and inside the disused tunnels will be covered by hessian bags during the works. Detailed tree survey reports and tree preservation reports will be carried out by specialist prior to and during the U/I works respectively. In principal, if the trees conditions were good or fair, no tree felling will be carried out. The condition of the trees will be closely monitored during the construction works.

3. ASSESSMENT OF CULTURAL SIGNIFICANCE

3.1 Criteria of Assessment

The principles and methodology of accessing the cultural significance of Duddell Street Steps and Gas Lamps are directly based on procedures laid out in two internationally accepted publications: the *Australia ICOMOS Burra Charter* (1999) and *The Conservation Plan* (2000).

The concept of “cultural significance” embraces the cultural heritage values of heritage places to the community, which cannot be expressed in financial terms alone. Assessment of cultural significance endeavours to establish why such a place is considered important and valued by the community. Significance, therefore, is embodied in the fabric of the place, including the setting, the records associated with the place and the response that the place evokes in the community.

Significance is normally evaluated or expressed through the preparation of a “Statement of Cultural Significance” which answers the question “Why is the site important?” Sections below identify the cultural significance for Duddell Street Steps and Gas Lamps in this format. The assessment is intended to enable decisions on the future management of the declared monument as a heritage place. The objective is to ensure that the cultural heritage values of the place is understood so that future decisions do not destroy the place’s significance but continue to conserve it for future generations.

With reference to the *Burra Charter*, the cultural significance of a heritage place is assessed under the categories of social, historical, aesthetic and architectural values.

3.2 Statement of Cultural Significance

It is believed that the Duddell Street Steps and Gas Lamps were built between 1875 and 1889. The gas lamps in two-light Rochester models constructed on lanterns shape balusters fully demonstrate the adaptation of a western construction style to Hong Kong local culture and climate.

3.2.1 Social Significance

As the only working gas lamps in Hong Kong, the Duddell Street gas lamps constructed in two-light Rochester models have lit the Central districts between every night for over a century and symbolize the unique social significance and collective memories of Hong Kong people.

On the other hand, the romantic atmosphere generated by the gas lamps in every evening has attracted many visitors, movies and television

programmes producers to take photography scene at the classical stone steps and the ancient gas lamps. The declared monument has become one of the famous points of interests in Hong Kong.

3.2.2 Historical Significance

Central, with its proximity to Victoria Harbour, has served as the trading and financial centre since the earliest day of British colonial era in 1841, and continues to flourish and serve as the administrative centre after the transfer of sovereignty to China in 1997. On the other hand, the Duddell Street Steps and Gas Lamps which located at the Central district have also been serving the society for more than 100 years as a linkage between the mid-levels and the Central. The Hong Kong Government has once proposed to conserve the 4 numbers of gas lamps in the Hong Kong Museum of History but for the historical interest, these gas lamps were retained at their original locations and maintained by the Hong Kong and China Gas Company. The Duddell Street Steps and Gas Lamps are declared as monuments of Hong Kong in 1979 and it symbolized the historical significances of fabric construction in the early days and the witness of time changes in Hong Kong.

3.2.3 Architectural and Aesthetic Significance

Back in 1842, the Central district was zoned for Westerners only, and the Chinese residents were resided to the Sheung Wan district. Many “Western-style buildings” were built at the Central district which largely dominated by the presence of ancient Greek styles. However, as more and more historical buildings were disassembled in the past decades, buildings with ancient Greek styles in Hong Kong were decreasing. The Duddell Street Steps and Gas Lamps built in the 18th century have adopted the western construction styles which can be reflected in both the patterns of lantern shape balustrades and golden colour lamp posts. The architectural and aesthetic significance can also be seen through the construction details of the arch lintel at both storeroom entrances.

3.3 **Possible Cultural Impact during the Construction Works**

AMO set up a Heritage Trail in the Central and Western Districts with the generous financial support of the Hong Kong Jockey Club Charities Trust. The Trail links up historic buildings and sites, enabling travellers to have a better understanding of the growth and development of the Districts. The entire Heritage Trail comprises three routes which were launched in three phases: the Central Route, the Sheung Wan Route and the Western District and the Peak Route which were launched in October 1997, July 1999 and December 2000 respectively. They have been well received by the public.

Forming part of the Central Route, the Duddell Street Steps and Gas Lamps has demonstrated the architectural and aesthetic significance in the 18 century to enable visitors to recapture landmarks of the Central District. However, during the construction works, the exterior appearance of the declared monument may have slight impact. Area within 3m from the existing Feature No. 11SW-B/R93 will be fenced off by hoarding. Part of the sidewalls and the doors of storerooms will be protected by polyfoam board and the footpath will be covered by planking. Since the major part of the declared monument will not be disturbed during the construction period, it is anticipated that no significant adverse impacts to the visitors or passers-by, as well as the trail will be observed.



3.4 Significant Features

The declared monument has different levels of significance. This assessment of significance is to facilitate decisions to be made on the future conservation of the historic fabrics and preservation works during the construction period. The categories of assessment are based on the Conservation Plan by J. Kerr.

Levels of Significance	Meaning
Exceptional	Where an Individual space or element is assessed as displaying a strong contribution to the overall significance of the place. Spaces, elements or fabric exhibit a high degree of intactness and quality, though minor alterations or degradation may be evident.
High	Where an individual space or element is assessed as making a substantial contribution to the overall significance of the place. Spaces, elements of fabric originally of substantial quality, yet may have undergone considerable alteration or adaptation resulting in presentation which is either incomplete or ambiguous. The category also includes spaces, elements or fabric of average quality in terms of design and materials, but which exhibit a high degree of intactness.
Moderate	Where an individual space or element is assessed as making a moderate contribution to the overall significance of the place. Spaces, elements or fabric originally of some intrinsic quality, and may have undergone alteration or degradation. In addition, elements of relatively new construction, where the assessment of significance is difficult, may be included. This category also includes original spaces, elements or fabric of any quality which have undergone extensive alteration or adaptation.

Levels of Significance	Meaning
Low	Where an individual space or element is assessed as making a minor contribution to the overall significance of the place, especially when compared to other features. Spaces, elements or fabric originally of little intrinsic quality, any may have undergone alteration or degradation. This category also includes original spaces, elements or fabric of any quality which have undergone extensive alteration or adaptation to the extent that only isolated remnants survive (resulting in a low degree of intactness and quality of presentation).
Neutral	Where an individual space or element is assessed as having an unimportant relationship with the overall significance of the place. Spaces elements or fabric are assessed as having little or no significance.
Intrusive	Where an individual space or element detracts from the appreciation of cultural significance, by adversely affecting or obscuring other significant areas, elements or items.

3.4.1 Assessment of Levels of Significances – Stone Steps

Element	Photo	Levels of Significance
<p>Parapet Walls (refers to Section 2.2.1.1)</p>		<p>High</p>
<p>The short granite walls were located at the north-western and south-western crest of the feature adjacent to the box newels and gas lamps.</p>		
<p>Box newels (refers to Section 2.2.1.3)</p>		<p>High</p>
<p>A total of 12 box newels were located along the stone steps, i.e. 2 supporting the gas lamps at the feature crest, 8 located in the upper and</p>		

lower landings, and 2 located at the feature toe supporting the gas lamps.

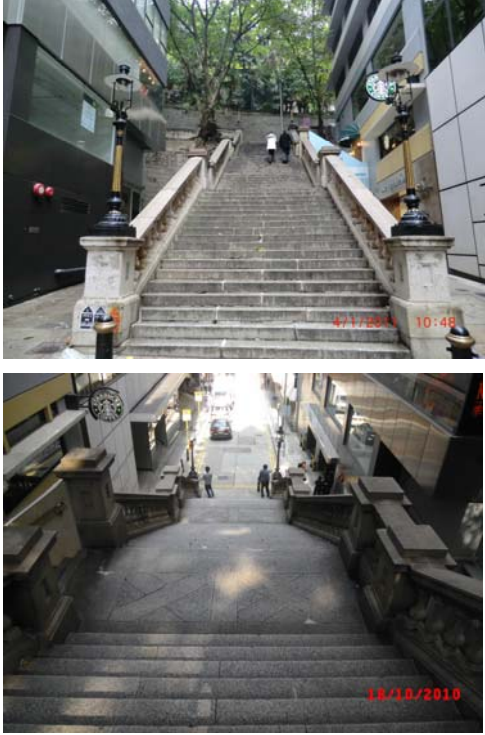
Element	Photo	Levels of Significance
<p>Granite stone staircase including the 2 landings and 56 treads (refers to Section 2.2.1.2)</p>		<p>Exceptional</p>

The granite stone staircase formed by 56 treads is separated into 3 sections by 2 landings.

<p>Granite stone handrailing including all original and imitation balusters (refers to Section 2.2.1.3)</p>		<p>Exceptional</p>
--	--	--------------------

The granite stone handrailings are connected numerous of lantern shape balusters and separated into 3 sections similar to the treads.

Element	Photo	Levels of Significance
<p>Granite masonry blocks on the sidewalls of the staircase and their patterns (refers to Section 2.2.1.5)</p>		<p>Exceptional</p>
<p>The granite masonry blocks installed on the sidewalls of the staircase are considered to be part of the declared monument.</p>		

3.4.2 Assessment of Levels of Significances – Gas Lamps

Element	Photo	Levels of Significance
<p>Gas Lamps (refers to Section 2.2.1.4)</p>		<p>Exceptional</p>
<p>4 gas lamps, 2 located at the feature crest and 2 located at the feature toe, were made by Suggus and Co.</p>		



3.4.3 Assessment of Levels of Significances – Storerooms underneath the Staircase

Element	Photo	Levels of Significance
<p>Storerooms including the arch ceiling in Storeroom #1 and granite beams at the ceiling of Storeroom #2 (refers to Section 2.2.1.6)</p>		<p>High</p>
<p>The storerooms are currently occupied by miscellaneous items by LCSD.</p>		

Element	Photo	Levels of Significance
<p>Storerooms including the black wooden door and transparent glass window at the southern side of Storeroom #1; the brick transom window with steel frame at the northern side of Storeroom #1, and the black rectangular steel gate at Storeroom #2 (refers to Section 2.2.1.6)</p>	 <p>The top photo shows an interior view through a black wooden door with a glass window, looking into a storeroom with a brick wall and a blue barrel. The middle photo shows a brick transom window with a steel frame set into a brick wall. The bottom photo shows a black rectangular steel gate set into a stone wall, with a person in a blue uniform standing in front of it.</p>	<p>Neutral</p>
<p>The black wooden door, transparent glass window and brick transom window with steel frame at Storeroom #1, and the black rectangular steel gate at Storeroom #2 were constructed at the declared monument.</p>		

3.4.4 Assessment of Levels of Significances – Disused Tunnels

Element	Photo	Levels of Significance
<p>Portal Nos. 43 and 44 (refers to Section 2.2.2)</p>		<p>Moderate</p>
<p>The two disused tunnels with portals namely Portal 43 and Portal 44 are located at the toe of north-western and south-western portion of the feature respectively.</p>		

Element	Photo	Levels of Significance
<p>The concrete counterforts and the brick walls adjacent to above Portals 43 and 44 (refers to Section 2.2.2)</p>		<p>Moderate</p>
<p>Counterforts were observed on the surface of Feature No. 11SW-B/R93 above both portals.</p>		
<p>The masonry sidewalls and rows of flat precast reinforced concrete lintels at the ceilings of tunnels behind Portals 43 and 44 (refers to Section 2.2.2)</p>		<p>Moderate</p>
<p>At the end of both existing disused tunnels are backfilled by large amount of boulders and cement.</p>		

3.4.5 Assessment of Levels of Significances – Wall Trees

Element	Photo	Levels of Significance
<p>The two existing wall trees namely <i>Ficus virens</i> var. <i>sublanceolata</i> (refers to Section 2.2.6)</p>		<p>Moderate</p>
<p>Two wall trees were grown on wall surface above Portals 43 and 44.</p>		

4 HERITAGE IMPACT ASSESSMENT AND MITIGATION MEASURES

4.1 Context

Heritage impact assessment is undertaken to identify the impacts, both direct and indirect, on the heritage sites by the proposed U/I works based on the result of desktop research and field evaluation.

During the assessment, both the direct impacts such as loss or damage of important features as well as indirect impacts will be clearly stated, such as adverse visual impact on the declared monument, landscape change of access to the heritage sites during the construction period, impact in its settings causing impingement on its character through inappropriate sitting or design, potential damage to the physical fabric of archaeological remains, historic buildings or historic landscapes through air pollution, change of ground level or water level, vibration, recreation pressure and ecological damage by the construction works which may affect the preservation of the declared monument in situ during the implementation stage of the project.

The evaluation of HIA is classified into five levels of significance based on type and extent of the effects concluded in the HIA study:

- a. Beneficial impact:
The impact is beneficial if the project will enhance the preservation of the heritage site(s) such as improving the flooding problem of the historic building after the sewerage project of the area;
- b. Acceptable impact:
If the assessment indicates that there will be no significant effects on the heritage site(s);
- c. Acceptable impact with mitigation measures:
If there will be some adverse effects, but these can be eliminated, reduced or offset to a large extent by specific measures, such as conduct a follow-up Conservation Proposal or Conservation Management Plan for the affected heritage site(s) before commencement of work in order to avoid any inappropriate and unnecessary interventions to the building;
- d. Unacceptable impact:
If the adverse effects are considered to be too excessive and are unable to mitigate practically;
- e. Undetermined impact:
If the significant adverse effects are likely, but the extent to which they may occur or may be mitigated cannot be determined from the study. Further detailed study will be required for the specific effects in question.

The overall effects after application of mitigation measures will be assessed with four levels of impact, from “High”, “Medium”, “Low” to “Neutral”

- a. High:
An impact that significant alters or obliterates significant characteristics of the heritage resource;
- b. Medium:
An impact that alters the character or surroundings of the heritage resource, but is consistent with existing and emerging trends;
- c. Low:
An impact capable of measurement but with no alteration of significant characteristics;
- d. Neutral
A change that does not affect the value of the heritage resource and/or its surroundings.

4.2 Potential Impacts and Mitigation Measures on the Heritage Site

Proposed U/I works:	Installation of soil nails of approximately 16m long at 1m c/c horizontal and vertical grid pattern and construction of a 250mm thick skin wall with stone facing in front of the existing feature.
Affected Elements:	(i) Retaining wall No. 11SW-B/R93 adjacent to the declared monument; (ii) Sidewalls of the declared monuments
Levels of significance:	<u>Acceptable impact with mitigation measures</u>
Photos:	Retaining wall No. 11SW-B/R93, Portals 43, 44 and Part of the Duddell Street Steps are shown below in Photos 3.1 and 3.2



Photos 4.1 and 4.2 – Existing retaining wall above Portals 43 and 44

Description of the Impacts and Proposed Mitigation Measures

Before the construction works, the visible area of the existing masonry retaining wall No. 11SW-B/R93 is very little and the wall is covered by tree roots and concrete counterfort. After installation of the proposed soil nails, construction of soil nail heads, and 250mm thick skin wall with stone facing, except Portal 43 and 44, Feature No. 11SW-A/R93 subdivision 1 will be entirely covered. Notwithstanding the construction of skin wall may cover the existing retaining wall, it may increase the stability of the feature by catering the brittle failure mode of the existing masonry wall. It may also further enhance the existing untidy appearance due to the tree roots and concrete counterfort. The pattern and size of the proposed masonry facing will match with the surrounding and blend in a harmonious atmosphere.

It is recommended that the proposed skin walls at the north-western and south-western sides to be constructed at an angle of 45° to the declared monument so that the declared monument will not be affected by the U/I works. All soil nail heads will be embedded in the proposed skin wall to form one retaining structure. The existing accesses to the storerooms underneath the staircase and all maintenance access will not be blocked after the proposed U/I works.

The proposed construction plans have been circulated to the Lighting Division of HyD, EMSD (the maintenance agent) and the Commercial Maintenance Section of the Hong Kong & China Gas Co. Ltd. Their comments are summarized below:

- The Lighting Division of HyD expressed no objection in principle from the lighting design view point under letter ref. (44DY) in HyD LTG/15-4/13/14) dated 5 February 2013 enclosed in Appendix H
- EMSD commented that proper dust suppression measures shall be provided to avoid any dust contamination to the antique lamps during the whole construction process, especially during soil nail/ raking drain construction so that proper lighting level on the stairway could be properly maintained.
- EMSD also advised that special attention or precautionary measures shall be arranged to safeguard any inadvertent damage of the antique lamps, especially during heavy lifting/ onsite handling of long rebars/ robust construction machinery such as drilling rigs and grouting setup.
- The Commercial Maintenance Section of the Hong Kong & China Gas Co. Ltd. emphasized that the works shall have no impact on the gas lamp and town gas piping nearby.

In order to provide proper dust suppression measures by requested by EMSD, the following operation will be implemented on site to minimize the dust contamination during the drilling works. A set of photos is enclosed in Appendix I for reference:

- A wet sponge will be placed on the slope surface to absorb most of the fine dust generated during drilling works (see photo no. 1);
- A plywood will be placed and mounted on the sponge to fix the sponge in place (see photo no. 2);
- First layer of tarpaulin will be placed above the sponge, the plywood and covering the opening of the drillhole (see photo no. 3);
- Second layer of tarpaulin will be covering everything including the front portion of the drilling rig (see photo no. 4);
- Sprinkler of water should be used to minimize the dust generated only when necessary;
- Stroke length between each drill run and air flushing will be reduced to approximately 300~500mm instead of a single drill run of 1.5m; and
- Pressure for air flushing will be minimized in order to reduce the dust generated by air flushing.

During the operation, the site will be fenced off by hoarding as mentioned in Section 3.3. The four gas lamps will be located outside of the hoarding and chance of inadvertently damaging these lamps will be very low. Furthermore, as discussed with the Hong Kong & China Gas Co. Ltd., there will be no conflict between the proposed soil nailing works and existing town gas utilities. The full set of defect report and one week advance notification of works will be given to the Hong Kong & China Gas Co. Ltd. prior to the commencement of construction of soil nails.

During the construction stage, the vibration and dust generated during the soil nailing and concreting works will be measured and minimized. It is anticipated that the impacts due to vibration and dust is insignificant to the declared monuments. However, ground settlement markers and building settlement markers will be installed in the vicinity of the site to monitor any adverse effects occurred due to the works. Existing piezometers along Ice House Street will be monitored to ensure that no significant groundwater draw down being occurred. Other monitoring such as air pollution monitoring, dust pollution monitoring, vibration monitoring and noise monitoring will be implemented and assessed to ensure that the proposed U/I works are carried out in a safe and non-nuisance condition.

Part plans and photomontages showing the proposed U/I works and the appearance of Feature No. 11SW-B/R93 upon completion of works are attached in Appendix J for easy reference.

The overall effects after application of mitigation measures are considered to be “Medium”.

4.3 Potential Impacts on the Wall Trees

Proposed U/I works: Construction of a 250mm thick skin wall with

Affected Elements: stone facing in front of the existing feature.
The existing wall trees located at the crest of Feature No. 11SW-B/R93

Levels of significance: Acceptable Impacts

Photos: Existing wall trees at the crest of Feature No. 11SW-B/R93 are shown below in Photos 3.3 and 3.4



Photos 4.3 and 4.4 – Existing wall trees located above Portals 43 and 44.

Description of the Impacts and Proposed Mitigation Measures

According to the tree surveys carried out by HyD and Arup, the conditions of the existing trees (*Ficus virens* var. *sublanceolata*) along the crest of Feature No. 11SW-B/R93 are considered to be fair with no significant defect observed.

During the setting out for the proposed U/I works, all soil nails will be installed at a location with at least 300mm clearance from the adjacent tree roots. If necessary, landscape architect will be consulted if trimming of existing tree roots is required.

A gap of approximately 300mm thick will be reserved between the face of the existing masonry wall and the back of the proposed skin wall. Aggregates will be placed inside the gap to allow air circulation for the roots of the existing wall trees. Within the gaps, all soil nails will be surrounded by permanent casing and double corrosion protection (DCP) sleeves in order to ensure that no contamination such as rusting on the soil nail reinforcement be occurred.

For the existing tree roots within the disused tunnels portion, tree protection such as covering by biodegradable hessian wraps will also be implemented before the backfilling works to prevent chafing. Backfilling materials will contain no materials or chemicals that are harmful to the tree health, e.g. cement or alkaline materials.

The above proposed U/I works have been discreetly discussed with the In-

house Certified Arborist and he supported that the filling of aggregate between the existing masonry wall and the proposed skin wall is feasible as aggregates may allow air circulation and would not suffocate the tree roots.

Part plans and photomontages showing the proposed U/I works and the appearance of Feature No. 11SW-B/R93 upon completion of works are attached in Appendix J for easy reference.

The overall effects after application of mitigation measures are considered to be “Medium”.

4.4 Potential Impacts on the Disused Tunnels Connecting Feature No. 11SW-B/R93

Proposed U/I works: Installation of soil nails of approximately 16m long at 1m c/c horizontal and vertical grid pattern, construction of a 250mm thick skin wall with stone facing in front of the existing feature and backfilling the disused tunnels with rockfill material or the like.

Affected Elements: The existing disused tunnels and Portal 43 & 44

Levels of significance: Acceptable Impacts

Photos: Existing Portals 43 and 44 are shown below in Photos 3.5 and 3.6

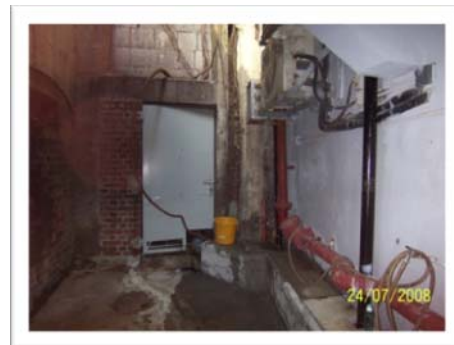

Photos 4.5 and 4.6 – Appearance of Existing Portals 43 and 44

Description of the Impacts and Proposed Mitigation Measures

During the proposed U/I works, the vibration generated by the soil nailing works and concreting works will be minimized. No significant influence on the stability of the existing disused tunnels and Portals 43 & 44 will be generated during and after the proposed U/I works. All soil nails will be installed at an angle of 10° dipping downwards. The tips of the lowest rows of soil nails will be penetrated above the backfilled portion of the Wyndham Street tunnel network as shown in Drawing No. AO/101/13/203 in Appendix G. The empty portions of the disused tunnels will be backfilled in reversible methods, using rockfill material or the like which

can be removed by others if necessary, in order to enhance the stability of the concerned tunnels during and other the proposed U/I works.

The conditions of the disused tunnels will be monitored during the proposed U/I works. Vibration assessment and ground settlement monitoring will be carried out in adequate intervals to ensure the conditions of the disused tunnels are not adversely affected by the proposed U/I works. Any defects or distress observed during the U/I works will be reported to the Engineer, the client (HyD) and the maintenance parties (CEDD) of the disused tunnels for remedial works.

The overall effects after application of mitigation measures are considered to be “Low”.

4.5 Potential Impacts on Existing Utilities on the Wall Surface and Drainage Channel within Portal 43

Proposed U/I works: Installation of soil nails of approximately 16m long at 1m c/c horizontal and vertical grid pattern

Affected Elements: Existing utilities on the wall surface and drainage channel within Portal 43

Levels of significance: Undetermined impact

Photo: Existing utilities such as cables and drainage channels located on the wall surface and wall toe are shown below in Photos 3.7 and 3.8

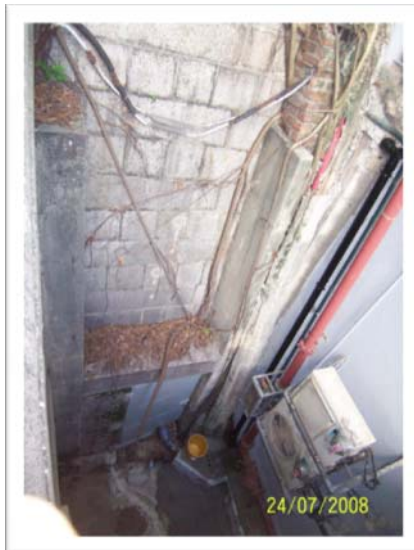

Photos 4.7 and 4.8 – Existing utilities and drainage channels are located on the wall surface and wall toe of Portal 43.

Description of the Impacts and Proposed Mitigation Measures

According to the desk-top research and field evaluation, some utilities were found located on Feature No. 11SW-B/R93 (see Section 2.2.5 for

details). These utilities include electricity cables, gas pipes, telephone lines, optical fibers and drainage channels. Other than the drainage channels within Portal 43, all the mentioned utilities are located on the surface of the retaining wall in which diversion or relocation works for such utilities can be carried out without major impacts to the declared monuments. However, some of the utilities were hidden behind the brick walls at the north-western side of the Feature, the existing conditions of these utilities are unknown and further investigation by specialists shall be required prior to the commencement of the proposed U/I works. Thus, it is considered that the significant adverse effects are likely but the impact cannot be determined at the current stage.

For the drainage channels located on the ground level of the existing disused tunnel and Portal 43, installation of soil nails shall have no adverse effect to the utilities.

The overall effects after application of mitigation measures are considered to be “Neutral”.

5 IMPLEMENTATION

5.1 Documentation

Before the commencement of any works on site, a detailed photographic and cartographic survey will be conducted by experienced surveyors/conservationist to provide important reference to all completed U/I works. These survey reports, all HIA studies and site inspection records will be kept at the site office and made available to the users and professionals who are responsible for up-keeping the declared monument and managing the changes of the heritage site.

Documentation of the whole U/I works and mitigation measures, from conceptualization to implementation stage will also be required, so that an understanding of the changes to the heritage site is recorded to inform future care and maintenance. Such documentation, such as measured drawings and photos of the U/I works in process, may also from educational materials displayed to the public as part of the interpretation strategies. Upon the completion of the U/I works, all these documentations should be well kept by HyD and AMO for record and similar U/I works reference.

BIBLIOGRAPHY

- Antiquities and Monuments Office Webpage, Antiquities and Monuments Office, Leisure and Cultural Services Department, The Government of the Hong Kong Special Administrative Region.
- Bard, Soloman. Voices from the past: Hong Kong, 1982-1918. Hong Kong: Hong Kong University Press, 2002.
- The Burra Charter, The Australia ICOMOS Charter for Places of Cultural Significance, 1999.
- Environmental Impact Assessment Ordinance (Cap. 499), Environmental Protection Department, The Government of the Hong Kong Special Administrative Region, February 1997.
- Guideline for Built Heritage Impact Assessment, Antiquities and Monuments Office, Leisure and Cultural Services Department, The Government of the Hong Kong Special Administrative Region, May 2008.
- Guide to Soil Nail Design and Construction, GeoGuide 7, Geotechnical Engineering Office, Civil Engineering and Development Department, The Government of the Hong Kong Special Administrative Region, March 2008.
- Heritage Impact Assessment Mechanism for Capital Works Projects, Development Bureau Technical Circular (Works) No. 6/2009, The Government of the Hong Kong Special Administrative Region, September 2009.
- Hong Kong Slope Safety Website, Geotechnical Engineering Office, Civil Engineering and Development Department, The Government of the Hong Kong Special Administrative Region.
- Hutcheon, Robin. The Blue Flame: 152 Years of Towngas in Hong Kong. Hong Kong: The Hong Kong and China Gas Company Limited, 1987.
- Kerr, J. S. Conservation Plan: A Guide to the Preparation of Conservation Plans for Places of European Cultural Significance. Sydney: National Trust of Australia (NSW), 2000
- Siu, Kin Kwok and Sham Sze. Hong Kong Heritage Trails. Hong Kong: Wan Li Book Co., Ltd, 2000.
- Slope Maintenance Responsibility Information System, Lands Department, The Government of the Hong Kong Special Administrative Region.
- Tilbrook, Brian. Duddell Street Steps and Gas Lamp – Hong Kong Heritage. Hong Kong: Government Information Service, 1989.
- Tree Management Office Webpage, Development Bureau, The Government of the Hong Kong Special Administrative Region.

- 梁炳華. 《都爹利街石階及煤氣燈柱 – 中西區風物志》，香港：中西區臨時區議會出版，1993年.
- 陳昕、郭志坤主編. 《香港全記錄》，卷一，香港：中華書局，1997年.
- 陳振邦. 《香港古蹟圖冊》，香港：文星圖書有限公司，2002年.
- 〈碩果僅存煤氣燈〉，《新報》，2002年7月25日.
- 〈發思古之幽情〉，《明報》，1987年10月9日.
- 劉天賜. 《香港老照片》，香港：天地圖書有限公司，1999年.

Appendix A

Slope No. : 11SW-B/R93

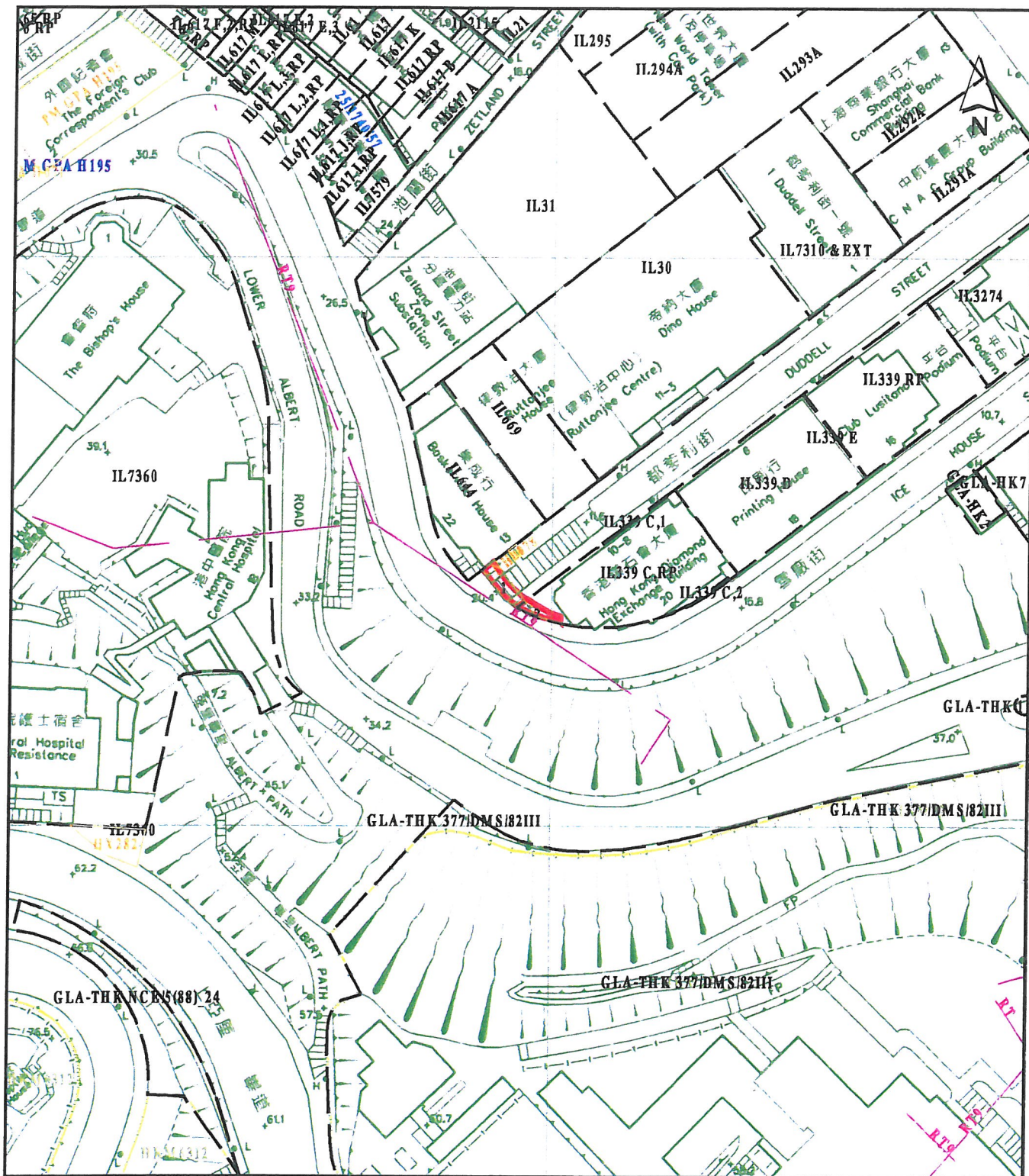

- Slope Boundary
- Lot Boundary
- Slope Boundary Enclosed Area

This plan is intended for **IDENTIFICATION** and **INTERNAL** use only. The information shown on this plan **MUST** be verified by field survey.



LANDS DEPARTMENT

Office: SIMAR Unit, Estate Management Section
Lands D. File Ref: SIM/11SW/BR93/HKW&S

CNPCS : CNPCS Date :

Part Print Survey Sheet No.
11-SW-13B 11-SW-8D

Scale : 1 : 1000
Date : 11-10-2006

LANDS D FILE REF. SIM/11SW/BR93/HKW&S

ENDORSED ON

07-FEB-05

SLOPE IDENTIFICATION

SLOPE NUMBER 11SW-B/R93	DLO DISTRICT(S) HKW&S
SURVEY SHEET NO.(S) 11-SW-8D	CO-ORDINATES N 815638 E 834194
LOCATION ADJOINING ICE HOUSE STREET & WITHIN IL339C,RP	

MAINTENANCE RESPONSIBILITY

NO. OF PARTIES 2	SUB-DIVISION NO. 1
PARTY RESPONSIBLE HyD	PERIOD UP TO
PERIOD REMARK PERMANENT	
MAINTENANCE AGENT HyD	
REASON 56 SLOPES ON UNALLOCATED GOVERNMENT LAND AFFECTING PUBLIC ROAD	
RELATED DOCUMENTS SLOPE PLAN	
LAND CATEGORY 5b(iii)	
WHOLE SLOPE AREA 28.75 m ²	SUB-DIVISION AREA 18.23 m ² % OF SUB-DIVISION AREA 63.42 %

ADDRESS OF RESPONSIBLE LOT

STREET NO & NAME	N/A
OR BUILDING/VILLAGE NAME ETC	N/A
ESTATE NAME	N/A

REMARKS**REMARKS 2**

LANDS D FILE REF. SIM/11SW/BR93/HKW&S

ENDORSED ON

07-FEB-05

SLOPE IDENTIFICATION

SLOPE NUMBER 11SW-B/R93	DLO DISTRICT(S) HKW&S
SURVEY SHEET NO.(S) 11-SW-8D	CO-ORDINATES N 815638 E 834194
LOCATION ADJOINING ICE HOUSE STREET & WITHIN IL339C,RP	

MAINTENANCE RESPONSIBILITY

NO. OF PARTIES 2	SUB-DIVISION NO. 2
PARTY RESPONSIBLE IL339C,RP	PERIOD UP TO 10-MAY-48
PERIOD REMARK	
MAINTENANCE AGENT N/A	
REASON 1 WITHIN PRIVATE LOT	
RELATED DOCUMENTS SLOPE PLAN	
LAND CATEGORY 1	
WHOLE SLOPE AREA 28.75 m ²	SUB-DIVISION AREA 10.52 m ² % OF SUB-DIVISION AREA 36.58 %

ADDRESS OF RESPONSIBLE LOT

STREET NO & NAME	20, ICE HOUSE STREET
OR BUILDING/VILLAGE NAME ETC	HONG KONG DIAMOND EXCHANGE BUILDING
ESTATE NAME	N/A

REMARKS

REMARKS 2

Appendix B

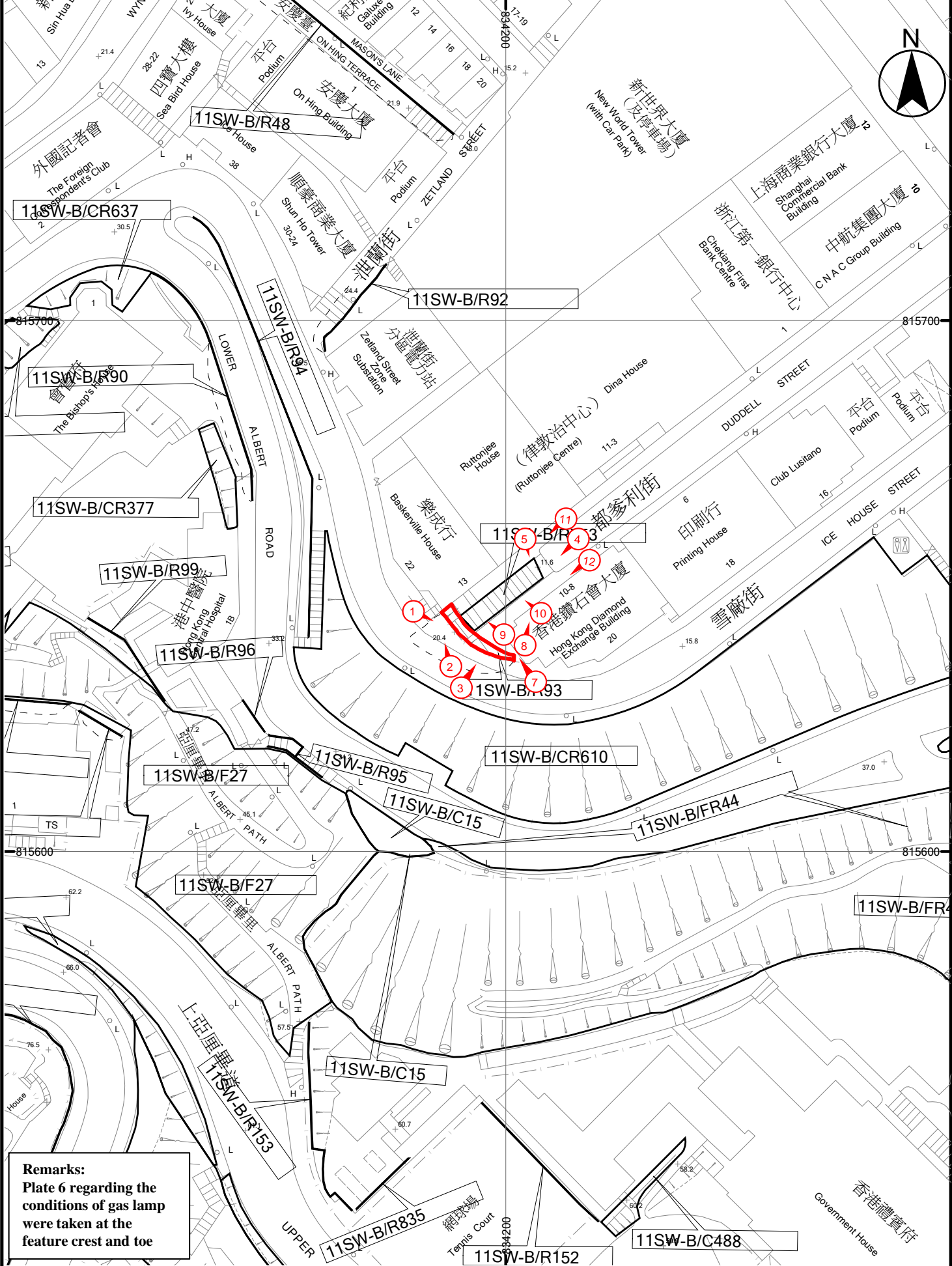

Remarks:
Plate 6 regarding the conditions of gas lamp were taken at the feature crest and toe

Job Title
AGREEMENT NO. CE 32/2004 (GE)
Upgrading/Improvement of Roadside Slopes/Retaining Walls on Hong Kong Island (2005 to 2008 Programme)
– Investigation, Design and Construction

Figure Title
Feature Location Plan
Feature No. 11SW-B/R93
Duddell Street

ARUP Ove Arup & Partners
Hong Kong Limited

Scale 1 : 1000

Drn. AY Date 09/2010 Chd. EC Passed AH

Job No. 24506 Appendix B

Job title Contract No. HY/2008/18

Job number: 24506

Location Duddell Street



Subject	Feature No. 11SW-B/R93 (Plate 1)	Date photograph taken	24-Jul-08
----------------	----------------------------------	------------------------------	-----------

Description	General view of the feature crest along Ice House Street
--------------------	--



Subject	Feature No. 11SW-B/R93 (Plate 2)	Date photograph taken	12-Jan-11
----------------	----------------------------------	------------------------------	-----------

Description	View showing the parapet wall at the North-western side of the Feature
--------------------	--

Job title Contract No. HY/2008/18

Job number: 24506

Location Duddell Street



Subject Feature No. 11SW-B/R93 (Plate 3) **Date photograph taken** 12-Jan-11

Description View showing the parapet wall at the South-eastern side of the Feature



Subject Feature No. 11SW-B/R93 (Plate 4) **Date photograph taken** 24-Jul-08

Description General view of the feature toe at Duddell Street

Job title Contract No. HY/2008/18

Job number: 24506

Location Duddell Street



Subject Feature No. 11SW-B/R93 (Plate 5) **Date photograph taken** 12-Jan-11

Description View showing the granite stone handrailings

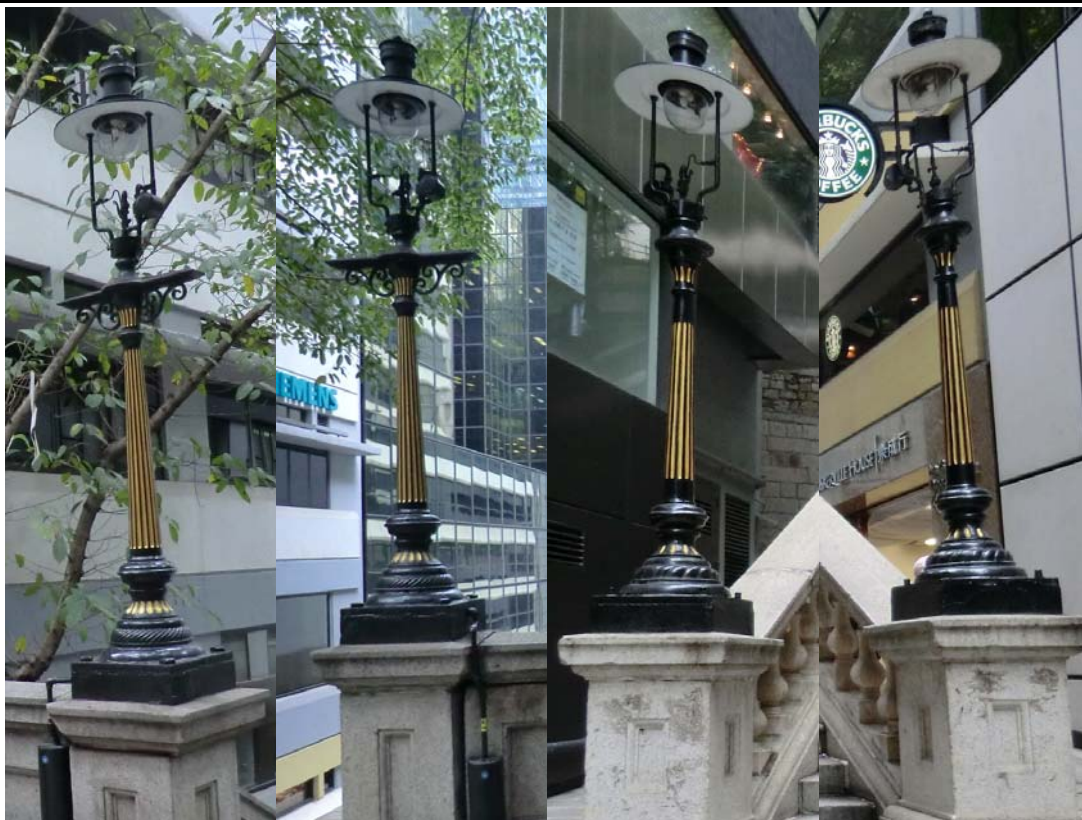

Subject Feature No. 11SW-B/R93 (Plate 6) **Date photograph taken** 12-Jan-11

Description View showing the conditions of the 4 gas lamps at Duddell Street

Job title Contract No. HY/2008/18

Job number: 24506

Location Duddell Street



Subject Feature No. 11SW-B/R93 (Plate 7) **Date photograph taken** 24-Jul-08

Description General view showing part of the sidewalls of the declared monument



Subject Feature No. 11SW-B/R93 (Plate 8) **Date photograph taken** 04-Jan-11

Description General view showing part of the sidewalls of the declared monument

Job title Contract No. HY/2008/18

Job number: 24506

Location Duddell Street



Subject	Feature No. 11SW-B/R93 (Plate 9)	Date photograph taken	07-Dec-07
----------------	----------------------------------	------------------------------	-----------

Description	General view showing the storeroom with a granite arch lintel above a wooden door		
--------------------	---	--	--



Subject	Feature No. 11SW-B/R93 (Plate 10)	Date photograph taken	27-Nov-07
----------------	-----------------------------------	------------------------------	-----------

Description	General view showing the storeroom with a rectangular steel gate		
--------------------	--	--	--

Job title Contract No. HY/2008/18

Job number: 24506

Location Duddell Street



Subject Feature No. 11SW-B/R93 (Plate 11) **Date photograph taken** 24-Jul-08

Description General view of the feature toe and Portal 43



Subject Feature No. 11SW-B/R93 (Plate 12) **Date photograph taken** 12-Jan-11

Description General view of the feature toe and Portal 44

Appendix C

Options	1 Construction of RC wall and backfilling disused tunnels	2 Installation of Permanent Soil Nails and construction of skin wall	3 Installation of Permanent Bored Pile Wall	4 Installation of Permanent Soil Nails with recessed soil nail heads
	<p style="text-align: center;">Section A-A</p>	<p style="text-align: center;">Section A-A</p>	<p style="text-align: center;">Section A-A</p>	<p style="text-align: center;">Section A-A</p>
Description of Works	Construction of a 600mm thick Reinforced Concrete (RC) wall with stone facing in front of the existing feature. Backfill the disused tunnel by mass concrete as the footing of RC Wall.	Installation of approximately 10 soil nails with 16m long at vertical and horizontal spacing of 1m c/c, inclined at 10 degrees. Construction of a 250mm thick skin wall with stone facing 300mm in front of the existing feature. The 300mm gap will be filled with aggregates. The existing disused tunnels will be backfilled with rockfill material or the like and the existing gate to the disused tunnels will be re-constructed	Installation of about 7 nos of 1.2m bored pile wall with 1.8m spacing c/c Total length of each pile is approximately 18m. Part of the existing disused tunnels behind Portals 43 a& 44 will be partially blocked.	Installation of approximately 10 soil nails with recessed soil nail heads at 14m long, 1m c/c in stagger pattern, inclined at 10 degrees. Existing gantry to Disused Tunnels Network No. 13 remains open.
Estimated Cost	HK\$ 0.91M	HK\$ 0.90M	HK\$ 2.88M	HK\$0.80
Construction Period	6 months	8 months	9 months	8 months
Priority of Option	2	1	3	Not Feasible
Design Consideration / Constraints	Permission must be granted from relevant government authorities prior to the backfilling of disused tunnels. Protection work for the existing trees located at the crest of the feature is required. Tree transplant or tree felling will not be carried out. The front face of feature and part of staircase will be covered by the proposed RC wall.	Protection work for the existing trees located at the crest of the feature is required. Tree transplant or tree felling will not be carried out. Precaution measures works for the disused tunnel shall be carried out if considered necessary. The front face of the feature will be covered by the proposed skin wall.	Relocation and protection works for the existing utilities will be required, i.e. 4 fibre optic cables located at the crest of the existing feature. Disturbances caused to the surrounding buildings or existing retaining wall by this option will be evident than the other options. Protection work for the existing trees located at the crest of the feature is required. Tree transplant or tree felling will not be carried out. Precaution measures works for the disused tunnel shall be carried out if considered necessary. Temporary Traffic Management (TTM) <u>must be required</u> for Ice House Street during U/I Works. 24-hour temporary closure for one of the traffic lanes along Ice House Street is required.	Protection work for the existing trees located at the crest of the feature is required. Tree transplant or tree felling will not be carried out. Precaution measures works for the disused tunnel shall be carried out if considered necessary.
<p>Job Title</p> <p>Agreement No.: CE 32/2004 (GE) Upgrading/Improvement of Roadside Slope/Retaining Walls on Hong Kong Island (2005 to 2008 Programme) Investigation, Design and Construction</p>	<p>Figure Title</p> <p>Feature No. 115W-B/R93 Duddell Street, Hong Kong</p> <p>Design Options</p>	<p>ARUP Ove Arup & Partners HK Ltd</p> <p>Scale 1:200</p> <p>Drn. Date 01/2013 Chd. EC</p> <p>Job No. 24506 Figure No. Appendix C</p>		

Appendix D

Job title Contract No. HY/2008/18

Job number: 24506

Location Bethanie, Pokfulam



Subject Feature No. 11SW-C/R307 (Plate 1) **Date photograph taken** 30-Apr-03

Description General view of the feature before upgrading works



Subject Feature No. 11SW-C/R307 (Plate 2) **Date photograph taken** 01-Dec-05

Description Formwork erection for the gap between the proposed mass concrete wall and existing masonry wall

Job title Contract No. HY/2008/18

Job number: 24506

Location Bethanie, Pokfulam



Subject Feature No. 11SW-C/R307 (Plate 3) **Date photograph taken** 30-Nov-05

Description View showing concreting works



Subject Feature No. 11SW-C/R307 (Plate 4) **Date photograph taken** 20-Dec-05

Description Mass concrete wall with masonry facing

Job title Contract No. HY/2008/18

Job number: 24506

Location Bethanie, Pokfulam



Subject Feature No. 11SW-C/R307 (Plate 5) **Date photograph taken** 07-Jan-06

Description Aggregates were filled in the gap for the existing tree roots



Subject Feature No. 11SW-C/R307 (Plate 6) **Date photograph taken** 09-Feb-06

Description Aggregates were filled in the gap for the existing tree roots

Job title Contract No. HY/2008/18

Job number: 24506

Location Bethanie, Pokfulam



Subject Feature No. 11SW-C/R307 (Plate 7) **Date photograph taken** 13-Feb-06

Description Mass concrete wall with masonry facing



Subject Feature No. 11SW-C/R307 (Plate 8) **Date photograph taken** 04-Mar-06

Description General view showing the completed upgrading works

CONTENTS

- A1. AERIAL PHOTOGRAPHS EXAMINED**
- A2. DETAILED SITE HISTORY**
- A3. PHOTOGEOLOGY / GEOMORPHOLOGY**
- A4. PAST INSTABILITY**
- A5. FILL**
- A6. COLLUVIUM**
- A7. EROSION**
- A8. VEGETATION AND SURFACE PROTECTION**
- A9. BOULDERS / ROCK EXPOSURE**
- A10. SURFACE HYDROLOGY**
- A11. SUMMARY OF FINDINGS**

A1. AERIAL PHOTOGRAPHS EXAMINED

A total of 17 sets of aerial photographs between the period of 1924 and 2004 were examined. The aerial photographs examined are shown in Table 1 below.

Table 1 List of Aerial Photographs Examined

Photo Year	Photo No	Flight Height (Feet)
1924	4029-30	Unknown
1945	Y01506-7	8 600'
1956	Y03188	16 700'
1963	Y07539-40	2 700'
1968	Y14108-9	Unknown
1972	1827	Unknown
1978	21966-7	2 000'
1979	27157-8	5 500'
1980	32005-6	5 500'
1984	57395-6	2 000'
1988	A14425-6	4 000'
1992	A32499-500	4 000'
1996	CN15686-7	5 000'
1997	CN17062-3	4 000'
2001	AW52235-6	4 000'
2003	CW53693-4	4 000'
2004	CW56990-1	4 000'

A2. DETAILED SITE HISTORY

Feature No. 11SW-B/R93 was formed prior to 1924, probably in association with the construction of Ice House Road. The Feature is a sub-vertical wall as observed in the aerial photographs. The hillside above the wall may have been excavated and back filled for the construction of the wall. A set of stairs extending up to the crest of the Feature had been formed by 1924. No visible changes can be observed on the Feature from the aerial photographs reviewed.

A3. PHOTOGEOLOGY / GEOMORPHOLOGY

The Feature is located at the junction between Ice House Road at its crest and Duddell Street at its toe. The Feature is located on the foothill of a northeast facing hillslope.

A4. PAST INSTABILITY

No past instability was observed on or near the Feature from the available photographs.

A5. FILL

Fill may have been placed on the area behind the wall and on the crest of the Feature for the construction of the wall and Ice House Road. As the Feature was already formed prior to 1924, the extent of fill could not be identified from the available aerial photographs.

A6. COLLUVIUM

No colluvium was observed on or near the Feature from the available photographs.

A7. EROSION

No erosional features could be observed on or near the Feature from the available photographs.

A8. VEGETATION AND SURFACE PROTECTION

The surface cover of the Feature could not be determined from all the available photographs due to obstructions of buildings and staircase below the Feature. Some minor vegetation appears to have grown on the surface of the Feature as observed from the 1979 aerial photographs.

A9. BOULDERS / ROCK EXPOSURE

No boulders or rock exposure were observed on or near the Feature from the available photographs.

A10. SURFACE HYDROLOGY

No natural or man-made drainage channel was observed on the Feature from the available photographs.

A11. SUMMARY OF FINDINGS

Feature No. 11SW-B/R93 was formed prior to 1924, probably in association with the construction of Ice House Road. No visible changes could be observed afterward.

The Feature is a sub-vertical wall with about 10 metres high. Excavation and back filling were probably carried out on the area behind the wall for the construction of the wall and Ice House Road. The extent of fill and wall type could not be determined from the aerial photographs reviewed.

No past instability, erosional feature, colluvium, boulders or rock exposures could be observed on the Feature.

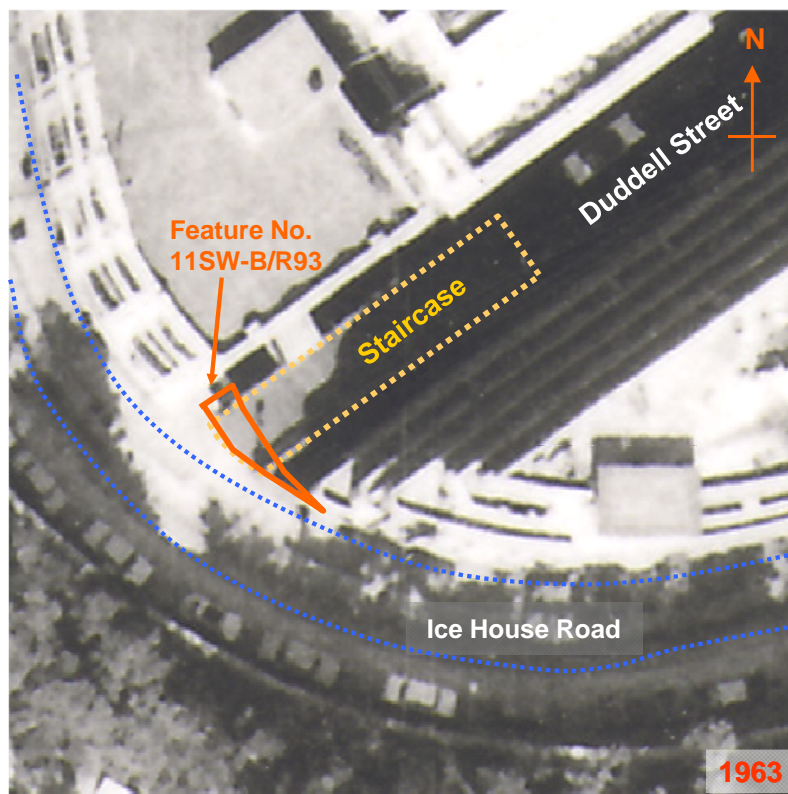

Year 1924-1979

- The earliest date of available aerial photographs is 1924.
- The Feature had been formed prior to 1924, probably in association with the construction of Ice House Road at its crest.
- The Feature was a sub-vertical wall about 10 metres high. The hillslope behind the retaining wall may have been cut and back filled.
- The extent of backfill and wall type could not be determined from the available aerial photographs.
- The building to the northwest of the Feature were redeveloped at some time between 1972 and 1976.
- A set of stairs were observed extending up to the crest of the slope and obscured the Feature wall face.

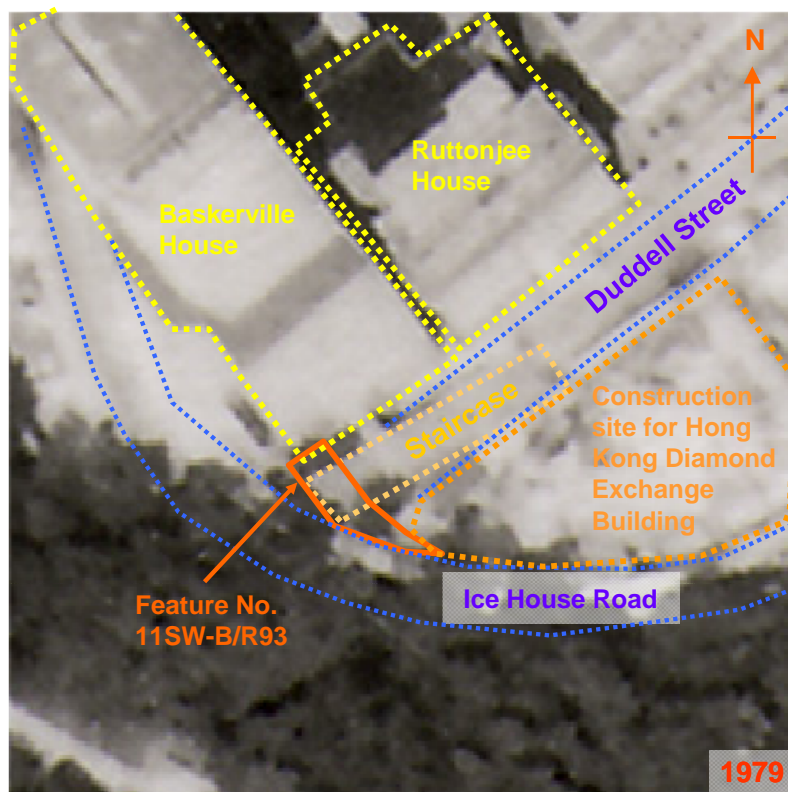

Year 1979-2004

- The building to the northeast of the feature was demolished and redeveloped at some time between 1979 and 1981. No visible disturbance could be observed on the Feature as a result of the construction work.
- No visible changes could be observed on the Feature since its formation.
- Some vegetation was observed on the Feature on the 1979 photograph.

<p>Job Title</p> <p>AGREEMENT NO. CE 32/2004 (GE)</p> <p>Upgrading/Improvement of Roadside Slopes/ Retaining Walls on Hong Kong Island (2005 to 2008 Programme)</p> <p>Investigation, Design and Construction</p>	<p>Figure Title</p> <p>Feature No. 11SW-B/R93 Duddell Street</p> <p>AERIAL PHOTOGRAPH INTERPRETATION</p>	<p>ARUP Ove Arup & Partners Hong Kong Limited</p>	
		<p>Scale NTS</p>	
		<p>Drn. PW Date 01/2006 Chd. MIW Passed</p>	
		<p>Job No. 24506</p>	<p>Appendix D</p>

*W C TSUI, Chief Technical Officer**Urban Region*

Repair Works to Duddell Street Stone Steps

Background of the Duddell Street Stone Steps and the four gas lamps

The Duddell Street Stone Steps were named after George Duddell, an auctioneer and ultimately a significant property owner in the area around the present Duddell Street in mid-19th century. It has not been possible to establish precisely when the Stone Steps were built. Serial maps of old Hong Kong indicate that the Stone Steps existed as early as 1875. In 1883 the Stone Steps were reconstructed at a cost of HK\$ 1,750.

The four gas lamps mounted on the top and foot of the granite steps are the only surviving functional gas street lamps in Hong Kong. The lamp posts, described as two-light Rochester models, were made by Suggs and Co. with shortened length so that they could be installed on the parapets of the steps. It is uncertain when the lamp posts were installed, although this model appeared in Suggs catalogue of 1922.

The records of the Hong Kong and China Gas Co. showed that the lamps were re-lit after World War II on 29 February 1948. Of the more than two thousand gas lamps which once lit Hong Kong's Streets, over a dozen were still being used in the early 1950s. In the 20 years followed, most of Hong Kong's gas lamps were gradually replaced by electricity lamps, and by September 1967 the gas company's records showed only the four Duddell Street gas lamps remaining. The company retained these gas lamps and continued operating them as objects of historical interest.



Duddell Street Stone Steps in 1979



One of the gas lamps in 1979

The first monument maintained by Highways Department (HyD)

HyD have been maintaining the flight of granite stone steps together with the four gas lamps as normal street furniture before they were declared as monument on 15 August 1979 under the Antiquities and Monuments Ordinance (Cap.53). According to our records, after the declaration, the stone steps and the four gas lamps became maintained by Architectural Services Department (ArchSD), as the maintenance agent of Antiquities and Monument Section of Leisure and Cultural Services Department (LCSD) (AMO) with funding provided by HyD. In mid 2008, one of the gas lamps together with the column located at the upper end of the Stone Steps at Ice House Street was found tilting significantly. Subsequently, HyD took up the maintenance of the four gas lamps and the stone steps and carry out urgent repair to the tilted gas lamp and the supporting stone column.



Special requirements in repairing the Stone Steps

As the Stone Steps are declared monument, AMO requires all the repair works to be carried out by a specialist contractor on the Works Bureau's approved list of "Repair and Restoration of Historic Building Category" to ensure the quality of works. Besides that, according to the Antiquities and Monuments Ordinance (Cap.53), a permit for repairing the Stone Steps should also be obtained from AMO.

Before commencement of work, the working drawings, schedule of work, method statements, materials to be used and related record photographs have to be submitted to AMO for their comments and approval. The materials to be used in repairing the Stone Steps is also restricted to lime mortar which has a better match with the original construction material rather than cement mortar usually used in civil engineering works.

The last but the most important requirement of the task is that no significant repair sign should be seen after the repair works.

Planning and Design

As HyD has no past experience in repairing and preservation of antiquities and monuments, particular specifications had to be prepared for the special

requirements. Reference had been made to the past maintenance records of ArchSD's maintenance work on the Stone Steps in preparing the working drawings, method statements and the particular specifications. Advices from AMO were also sought during the course of the preparation and planning works. During the planning and design stage, the conditions of the Stone Steps and 4 gas lamps were first surveyed as records and were monitored for any movements by our survey team.

In December 2008, AMO issued the Permit to HyD for the repair works of the Stone Steps and the 4 gas lamps. U(HK) then instructed the term contractor to employ a specialist contractor on the approved list of "Repair and Restoration of Historic Building Category" for the repair works.

The working drawings, programme of works, method statement and schedule of works were prepared and submitted to AMO for comments in October 2008 and finally approved by AMO.

Construction

In early July 2009, the repair works commenced. The Stone Steps were first cleaned using hand brushing and plain water for removal of dirt. No chemical or detergent was used in washing the staircase. A skillful workman filled up the cracks in the damaged balustrades at the handrail of the Stone Steps by lime mortar one by one and restored the balustrades to its original shape.



Specialist contractor repairing the damaged balustrades

During the restoration of the broken portion at the footing of the granite parapet adjacent to the gas lamp at the upper end of the Stone Steps, previous patches by cement mortar were removed and a granite stone cut to the size and shape of the broken portion was fixed to the cavity. The gap around the granite stone was filled with lime mortar and the granite stone was treated to match in color with the adjacent existing footing.



Damaged portion previously patched with cement mortar



Damaged portion after repairing by specialist contractor

The final stage of the repair works was the resetting of the tilted gas lamp sitting on a stone column next to the granite parapet mentioned above.

The gas lamp together with the stone column were tilted due to the intrusion of tree roots growing from an adjacent wall tree into the joints of the gas lamp and stone column.

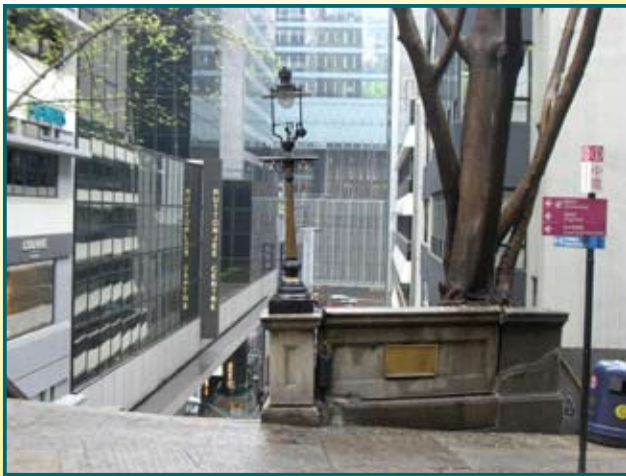

Tilted gas lamp and stone column at upper end of the Stone Steps



Roots from adjacent wall tree growing into joints of parapet wall and stone column

The sequence of the resetting of gas lamps works was as follows:

- The gas lamp and stone column were lifted up in two operations.
- The roots inside the stone column foundation were cleared under the direction of HyD's Landscape Architect.
- The stone column was re-fixed with lime mortar laid on the foundation.
- The gas lamp was set on the stone column with lime mortar and adjusted to vertical.



Lifting up the tilted gas lamp for the repair work



Clearing the surface of stone column for resetting the gas lamp



Clearing the tree roots from the foundation of stone column



Resetting the gas lamp and stone column to vertical

The job was successfully completed in about a month's time and in end August 2009.

Afterword

In the repair works of Duddell Street Stone Steps, we have the opportunity of repairing and preservation of declared monuments and learnt a lot of special repairing techniques which we had never come across before. In view of that Pottinger Street is likely to be declared as another monument soon, the experience of repairing Duddell Street Stone Steps will definitely be helpful in the future maintenance of similar declared street furniture there.

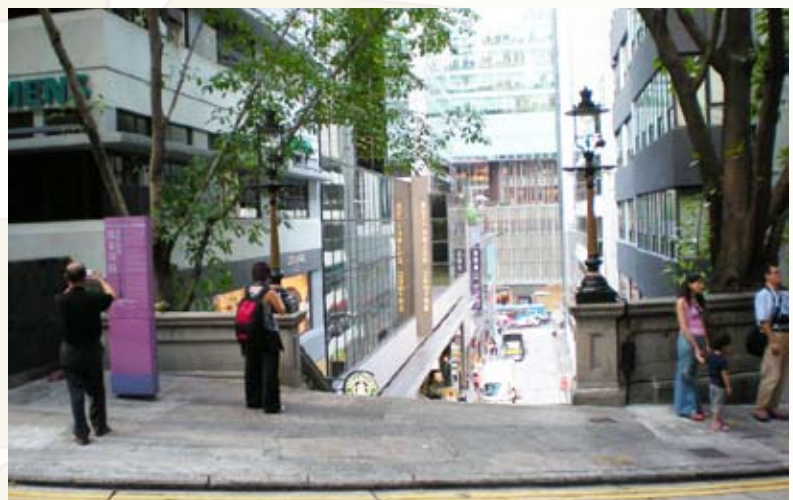





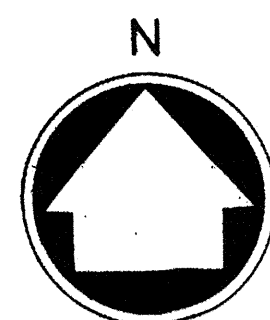

Duddell Street Stone Steps and gas lamps after repair works in August 2009

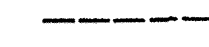
Appendix G

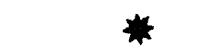

LEGEND

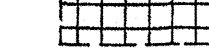
-  GRANITE MASONRY WALLS WITH P.C.C. LINTEL ROOF
-  INACCESSIBLE OR UNCERTAIN LENGTHS OF TUNNEL
-  INSITU CONCRETE LINED TUNNEL
-  BULKHEAD
-  BOREHOLE
-  CRACKING
-  SUBSIDENCE
-  BROKEN CHUNNAM

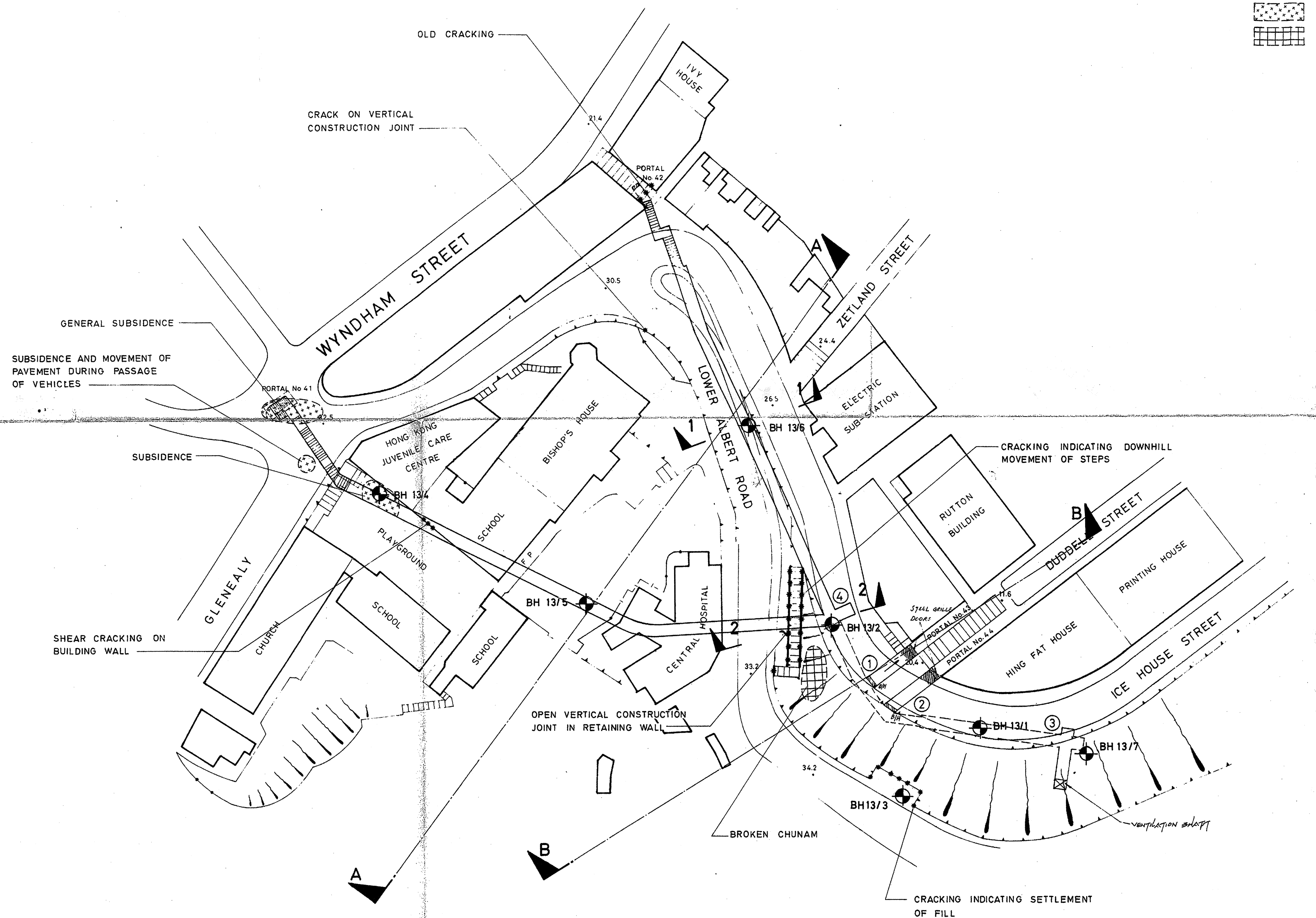

Rev.	Date	Description	By
		Highways Office Headquarters, Public Works Department, Empire Centre, Tsim Sha Tsui, Kowloon.	
		Consulting Engineers Mott, Hay & Anderson Far East. 2401 Sun Hung Kai Centre, 30 Harbour Road, Hong Kong.	
INVESTIGATION OF DISUSED TUNNELS FINAL REPORT WYNDHAM STREET NETWORK No.13 GENERAL LAYOUT AND GROUND SURFACE CONDITION			
Date: JAN, 82	Drawn By: Y/K. poon	Drg. No. A1/101/13/201	Rev:
Scale: 1:500			

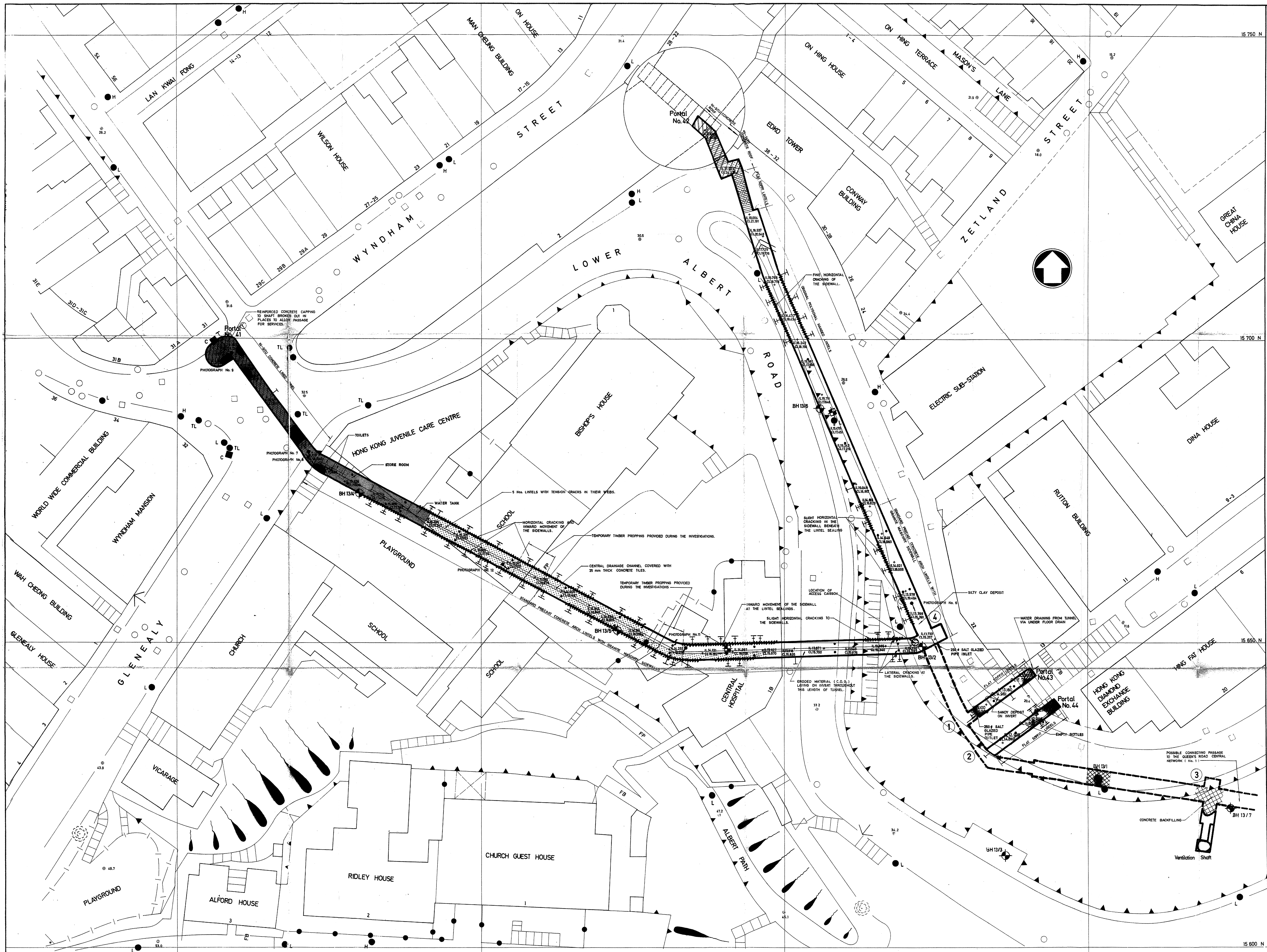

- NOTES:-**
- LEGEND**
- Granite masonry wall with P.C.C. lintel roof
 - Inaccessible or uncertain lengths of tunnel
 - In situ concrete lined tunnel
 - Proven backfilled tunnel
 - Area of ground water seepage (light/heavy)
 - Standing water
 - Unlined tunnel
 - Gunited tunnel
 - Longitudinal cracking of tunnel
 - Lateral cracking of tunnel
 - Inclined tunnel (up in direction of arrows)
 - Bulkhead (granite masonry/brick)
 - Grill/doors
 - Direction of drainage
 - Survey station
 - Tunnel junction and/or survey station number
 - Borehole
 - Trial pit
 - Tell tale
 - Spot level (tunnel) CROWN
 - Spot level (tunnel) INVERT
 - Spot level (surface) GROUND LEVEL
 - Area of observable ground water inflow
 - Area of access caisson
 - Probing hole
 - Cavehole

Rev.	Date	Description	By
Highways Office Headquarters, Public Works Department, Empire Centre, Tsim Sha Tsui, Kowloon.			
Consulting Engineers Mott, Hay & Anderson Far East. 8401 Sun Hung Kai Centre, 30 Harbour Road, Hong Kong			

INVESTIGATION OF DISUSED TUNNELS

FINAL REPORT

WYNDHAM STREET

NETWORK No. 13

TUNNEL DETAILS



水務署

Water Supplies Department

香港及離島分署
香港北角英皇道六十一號

Hong Kong and Islands Regional Office
611 King's Road, North Point, Hong Kong.

電子郵件 E-mail: wsdinfo@wsd.gov.hk

電話
Telephone 2880 2537

圖文傳真
Facsimile 2811 8152

檔號
Reference (14) in WSD(HK) 674/3/05

14 October 2005

Ova Arup & Partners Hong Kong Ltd.
Level 5, Festival Walk
80 Tat Chee Walk
Kowloon Tong
Kowloon
Hong Kong

Dear Sirs,

Agreement No. CE32/2004(GE)
Upgrading/Improvement of Roadside Slope/Retaining Walls
on Hong Kong Island (2005 to 2005 Programme)
Investigation, Design and Construction
Request for Existing Utility Information

I refer to your letter ref. 24506/GEO/0001ET-LETTER dated 4 October 2005.

I return one copy of our plans with the existing water mains and waterworks installations indicated. You are requested to note that the alignment of water mains shown is indicative only and although it is our intention to provide you with the most up to date information, we cannot guarantee that all recently laid mains have been incorporated in our central records and hence in the returned plans.

The exact lines and levels of the water mains as well as the materials that the water mains are made of should be established by hand dug trial holes on site if they are of significance to your works. You should instruct your consultants and/or contractors (as the case may be) to take all necessary measures during the design and/or construction stages (as the case maybe) to avoid causing damage to the water mains and waterworks installations, for which you will be held responsible.

Your attention is particularly drawn to the fact that some of the existing water mains, especially those in older urban areas, are asbestos cement pipes, which are vulnerable to damage when exposed. You are advised to conduct thorough site investigations to ascertain whether there are any asbestos cement pipes affected by the project, and to make special provisions as necessary to protect asbestos cement pipes identified on site. Should diversion/replacement of asbestos cement pipes be found necessary to be carried out in conjunction with your proposed works after detailed investigations or studies, You should instruct your consultants and/or contractors (as the case may be) to take all necessary measures during the design and/or construction stages (as the

case maybe) to comply with all prevailing statutory requirements for the safe handling, removal, transportation and disposal of asbestos cement pipes.

A copy of the Conditions of Working in the Vicinity of Waterworks Installations is attached for your appropriate action.

Please also comply with the following conditions:-

- (a) No cable or duct shall be laid in parallel and directly on top of any existing watermain.
- (b) A minimum clearance of 450mm shall be maintained between the new cable or duct and any adjoining watermains.
- (c) Where cross-over of any watermains is inevitable, the minimum clearance requirement stated in (b) shall also apply.

Yours faithfully,



(W. F. CHUNG)

for Chief Engineer/Hong Kong and Islands
Water Supplies Department

Encl.



水務署
Water Supplies Department

香港及離島分署
香港北角英皇道六一一號

Hong Kong and Islands Regional Office
611 King's Road, North Point, Hong Kong

電子郵件 E-mail: wsdinfo@wsd.gov.hk

電話

Telephone 2880 2529

圖文傳真

Facsimile 2811 8152

編號

Reference (14) in WSD(HK)674/2/05 TJ (1)

日期

Date 12 October 2005

Your Ref. 24506/GEO/0001ET-Letter

Ove Arup & Partners
Level 5, Festival Walk
80 Tat Chee Avenue
Kowloon Tong, Kowloon
Hong Kong

Dear Sirs,

ARUP		Job No.	24506
Reply Ref.		Job No.	6-3-f
Action Required:		Date	
Received 12 OCT 2005			
E. B. B. B.			
1			

*Please
pls request for
replacement features*

billio

Agreement No. CE 32/2004 (GE)

**Upgrading/Improvement of Roadside Slope/Retaining Walls
on Hong Kong Island (2005 to 2008 Programme)
Investigator, Design and Construction
Request for Existing Utilities Information**

I refer to your above referenced letter of 04-10-2005.

I also enclose herewith one copy of our plan(s) with the existing water mains and waterworks installation indicated. You are requested to note that the alignment of water mains shown is indicative only and although it is our intention to provide you with the most up to date information, we cannot guarantee that all recently laid mains have been incorporated in our central records and hence in the enclosed plan(s).

The exact lines, levels and material types of the water mains should be established by hand dug trial holes on site if they are of significance to your works. Please take all necessary steps to avoid damage to existing waterworks installations for which you will be held responsible. please do not hesitate to contact my senior inspector Mr. WONG Ming-chun at Tel No. 2880 2531.

Your attention is particularly drawn to the fact that some of the existing water mains, especially those in older urban areas, are asbestos cement pipes, which are vulnerable to damage when exposed. You are advised to conduct thorough site investigations to ascertain whether there are any asbestos cement pipes affected by the project, and to make special provisions as necessary to protect asbestos cement pipes identified on site. Should diversion/replacement of asbestos cement pipes be found necessary to be carried out in conjunction with your proposed works after detailed investigations or studies, you should instruct your consultants and/or contractors (as the case may be) to take all necessary measures during the design and/or construction

stages (as the case maybe) to comply with all prevailing statutory requirements for the safe handling, removal, transportation and disposal of asbestos cement pipes.

A copy of "Conditions of Working in the Vicinity of Waterworks Installations" is attached for appropriate action.

Yours faithfully

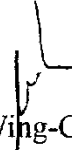

(KWOK Wing-Cheong)
For Chief Engineer/Hong Kong & Islands
Water Supplies Department

Encl.



水務署
Water Supplies Department

香港及離島分署
香港北角英皇道六一一號

Hong Kong and Islands Regional Office
611 King's Road, North Point, Hong Kong

電子郵件 E-mail: wsdinfo@wsd.gov.hk

電話

Telephone 2880 2529

圖文傳真

Facsimile 2811 8152

檔號

Reference (2) in WSD(HK)674/2/05 TJ (16)

日期

Date 17 October 2005

Your Ref. 24506/GEO/0002ET-Letter

Ove Arup & Partners
Level 5, Festival Walk
80 Tat Chee Avenue
Kowloon Tong, Kowloon
Hong Kong

Dear Sirs,

Agreement No. CE 32/2004 (GE)
Upgrading/Improvement of Roadside Slope/Retaining Walls
on Hong Kong Island (2005 to 2008 Programme)
Investigator, Design and Construction
Request for Existing Utilities Information

I refer to your above referenced letter of **05-10-2005**.

I also enclose herewith one copy of our plan(s) with the existing water mains and waterworks installation indicated. You are requested to note that the alignment of water mains shown is indicative only and although it is our intention to provide you with the most up to date information, we cannot guarantee that all recently laid mains have been incorporated in our central records and hence in the enclosed plan(s).

The exact lines, levels and material types of the water mains should be established by hand dug trial holes on site if they are of significance to your works. Please take all necessary steps to avoid damage to existing waterworks installations for which you will be held responsible. please do not hesitate to contact my senior inspector Mr. WONG Ming-chun at Tel No. **2880 2531**.

Your attention is particularly drawn to the fact that some of the existing water mains, especially those in older urban areas, are asbestos cement pipes, which are vulnerable to damage when exposed. You are advised to conduct thorough site investigations to ascertain whether there are any asbestos cement pipes affected by the project, and to make special provisions as necessary to protect asbestos cement pipes identified on site. Should diversion/replacement of asbestos cement pipes be found necessary to be carried out in conjunction with your proposed works after detailed investigations or studies, you should instruct your consultants and/or contractors (as the case may be) to take all necessary measures during the design and/or construction

stages (as the case maybe) to comply with all prevailing statutory requirements for the safe handling, removal, transportation and disposal of asbestos cement pipes.

As the captioned site is located within WSD upper direct gathering grounds, you are therefore required to comply with all the terms and conditions stipulated in the << Conditions of Working in Water Gathering Ground >>. A copy of this conditions is enclosed herewith for your information and necessary action.

A copy of "Conditions of Working in the Vicinity of Waterworks Installations" is attached for appropriate action.

Your proposed works encroach onto WSD water gathering ground, please submit written advance notice to our Engineer Mr. S.T. CHAN two weeks before commencement of works.

Yours faithfully



(KWOK Wing-Cheong)
For Chief Engineer/Hong Kong & Islands
Water Supplies Department

Encl.



水務署

Water Supplies Department

香港及離島分署
香港北角英皇道九十一號

Hong Kong and Islands Regional Office
611 King's Road, North Point, Hong Kong.

電子郵件 E-mail: wsdinfo@wsd.gov.hk

電話
Telephone 2880 2537

圖文傳真
Facsimile 2811 8152

編號
Reference (3) in WSD(HK) 674/3/05 TJ(13)

14 October 2005

Ova Arup & Partners Hong Kong Ltd.
Level 5, Festival Walk
80 Tat Chee Walk
Kowloon Tong
Kowloon
Hong Kong

Dear Sirs,

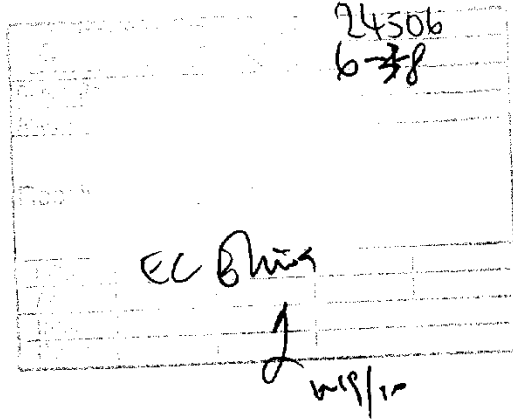

Agreement No. CE32/2004(GE)
Upgrading/Improvement of Roadside Slope/Retaining Walls
on Hong Kong Island (2005 to 2005 Programme)
Investigation, Design and Construction
Request for Existing Utility Information

I refer to your letter ref. 24506/GEO/0002ET-LETTER dated 5 October 2005.

I return one copy of our plans with the existing water mains and waterworks installations indicated. You are requested to note that the alignment of water mains shown is indicative only and although it is our intention to provide you with the most up to date information, we cannot guarantee that all recently laid mains have been incorporated in our central records and hence in the returned plans.

The exact lines and levels of the water mains as well as the materials that the water mains are made of should be established by hand dug trial holes on site if they are of significance to your works. You should instruct your consultants and/or contractors (as the case may be) to take all necessary measures during the design and/or construction stages (as the case maybe) to avoid causing damage to the water mains and waterworks installations, for which you will be held responsible.

Your attention is particularly drawn to the fact that some of the existing water mains, especially those in older urban areas, are asbestos cement pipes, which are vulnerable to damage when exposed. You are advised to conduct thorough site investigations to ascertain whether there are any asbestos cement pipes affected by the project, and to make special provisions as necessary to protect asbestos cement pipes identified on site. Should diversion/replacement of asbestos cement pipes be found necessary to be carried out in conjunction with your proposed works after detailed investigations or studies, You should instruct your consultants and/or contractors (as the case may be) to take all necessary measures during the design and/or construction stages (as the

case maybe) to comply with all prevailing statutory requirements for the safe handling, removal, transportation and disposal of asbestos cement pipes.

A copy of the Conditions of Working in the Vicinity of Waterworks Installations is attached for your appropriate action.

Please also comply with the following conditions:-

- (a) No cable or duct shall be laid in parallel and directly on top of any existing watermain.
- (b) A minimum clearance of 450mm shall be maintained between the new cable or duct and any adjoining watermains.
- (c) Where cross-over of any watermains is inevitable, the minimum clearance requirement stated in (b) shall also apply.

Yours faithfully,



(W. F. CHUNG)

for Chief Engineer/Hong Kong and Islands
Water Supplies Department

Encl.



水務署
Water Supplies Department

香港及離島分署
香港北角英皇道六十一號
Hong Kong and Islands Regional Office
611 King's Road, North Point, Hong Kong.

電子郵件 E-mail: wsdinfo@wsd.gov.hk

電話 2880 2534
Telephone

圖文傳真 2811 8152
Facsimile

檔號 (18) in WSD(HK)/674/1/05 TJ(15)
Reference

13 October, 2005

Ove Arup & Partners Hong Kong Ltd.
Level 5, Festival Walk,
80 Tat Chee Avenue,
Kowloon Tong, Kowloon,
Hong Kong.

(Attn.: Elvina Tam)

Dear Sir/Madam,

ARUP		Job No.	24506
Reply Ref.:		File No.	603-8
Action Required:		By:	603-8
Received		Date	17 OCT 2005
Inits.	ea		
Action			
Info.			
Copy	2		

603/10

Agreement No. CE32/2004 (GE)
Upgrading / Improvement of Roadside Slope/Retaining Walls
On Hong Kong Island (2005 to 2008 Programme)
Investigation, Design and Construction
Request for Existing Utility Information

I refer to your letter ref.:24506/GEO/0002ET-LETTER dated 5 October 2005.

I return herewith one copy of our plans with the existing water mains and waterworks installations in the vicinity duly indicated for your information. You are requested to note that the alignment of the water mains shown on the plan(s) returned is indicative only. Although it is our intention to provide you with the most up to date information, we cannot guarantee that the information returned to you is exhaustive. In particular, we cannot guarantee that all our water mains, especially those laid only recently, have been incorporated in our central records and hence on the plan(s) returned.

The exact lines and levels of the water mains as well as the materials that the water mains are made of should be established by hand dug trial holes on site if they are of significance to your works. You should instruct your consultants and/or contractors (as the case may be) to take all necessary measures during the design and/or construction stages (as the case maybe) to avoid causing damage to the water mains and waterworks installations, for which you will be held responsible.

Your attention is particularly drawn to the fact that some of the existing water mains, especially those in older urban areas, are asbestos cement pipes, which are vulnerable to damage when exposed. You are advised to conduct thorough site investigations to ascertain whether there are any asbestos cement pipes affected by the project, and to make special provisions as necessary to protect asbestos cement pipes identified on site. Should

diversion/replacement of asbestos cement pipes be found necessary to be carried out in conjunction with your proposed works after detailed investigations or studies, you should instruct your consultants and/or contractors (as the case may be) to take all necessary measures during the design and/or construction stages (as the case maybe) to comply with all prevailing statutory requirements for the safe handling, removal, transportation and disposal of asbestos cement pipes.

A copy of the Conditions of Working in the Vicinity of Waterworks Installations is attached for your reference.

Yours faithfully,



(K. C. LEE)

for Chief Engineer/Hong Kong & Islands
Water Supplies Department

Encl.

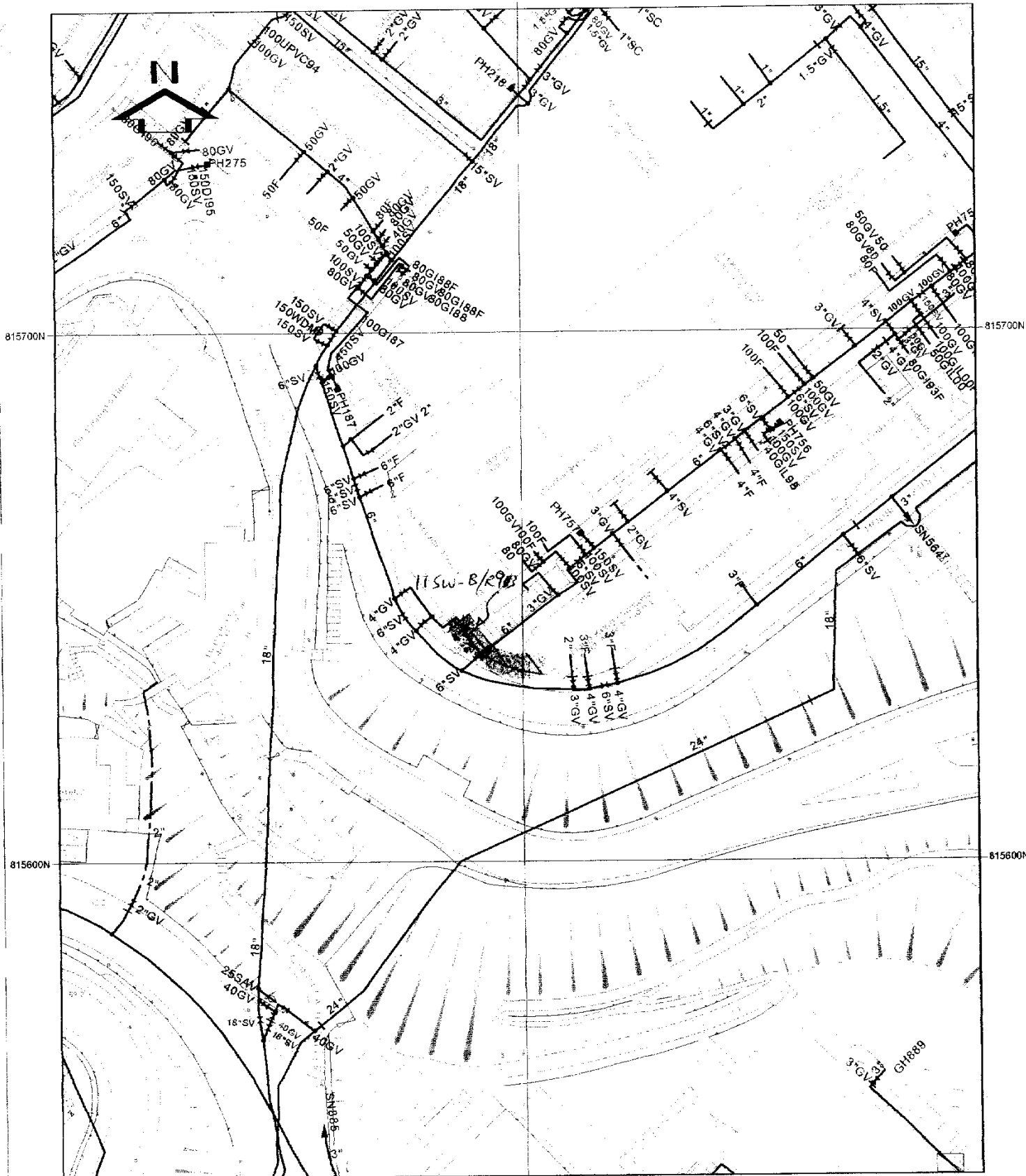

- NOTES:
1. ALL DIMENSIONS ARE IN MILLIMETRES UNLESS OTHERWISE SPECIFIED.
 2. ALL LEVELS ARE IN METRES ABOVE PRINCIPAL DATUM.
 3. INFORMATION ON ALIGNMENT OF MAINS IS OF INDICATIVE VALUE ONLY. WHERE POSITIONAL ACCURACY MAY BE OF IMPORTANCE, DETAILS SHOULD BE SITE CHECKED.
 4. FOR MAINS RECORDS SIGN CONVENTIONS AND DESIGNATIONS, PLEASE REFER TO DRAWING NO. SK 3988A ATTACHED.
 5. NO EXISTING W.S.D. CABLE IN THE VICINITY OF THE SITE.
 6. NO PROPOSED W.S.D. CABLE IN THE VICINITY OF THE SITE.
 7. THE SITE IS NOT WITHIN W.S.D. GATHERING GROUNDS.
 8. NO. W.S.D. RESERVE / LAND ALLOCATION WITHIN THE SITE AREA.

PART COPY OF FRESH WATER MAINS RECORD PLAN(S)

W67880/11-SW-8D & 13B

FILE REF: (13) IN WSD(HK) /674/2/05TJ1

REF. CODE:40W05M

SHEET 1 OF 1

SCALE 1:1000



水務署
Water Supplies Department

834200E

815700N

815700N

815600N

815600N

834200E

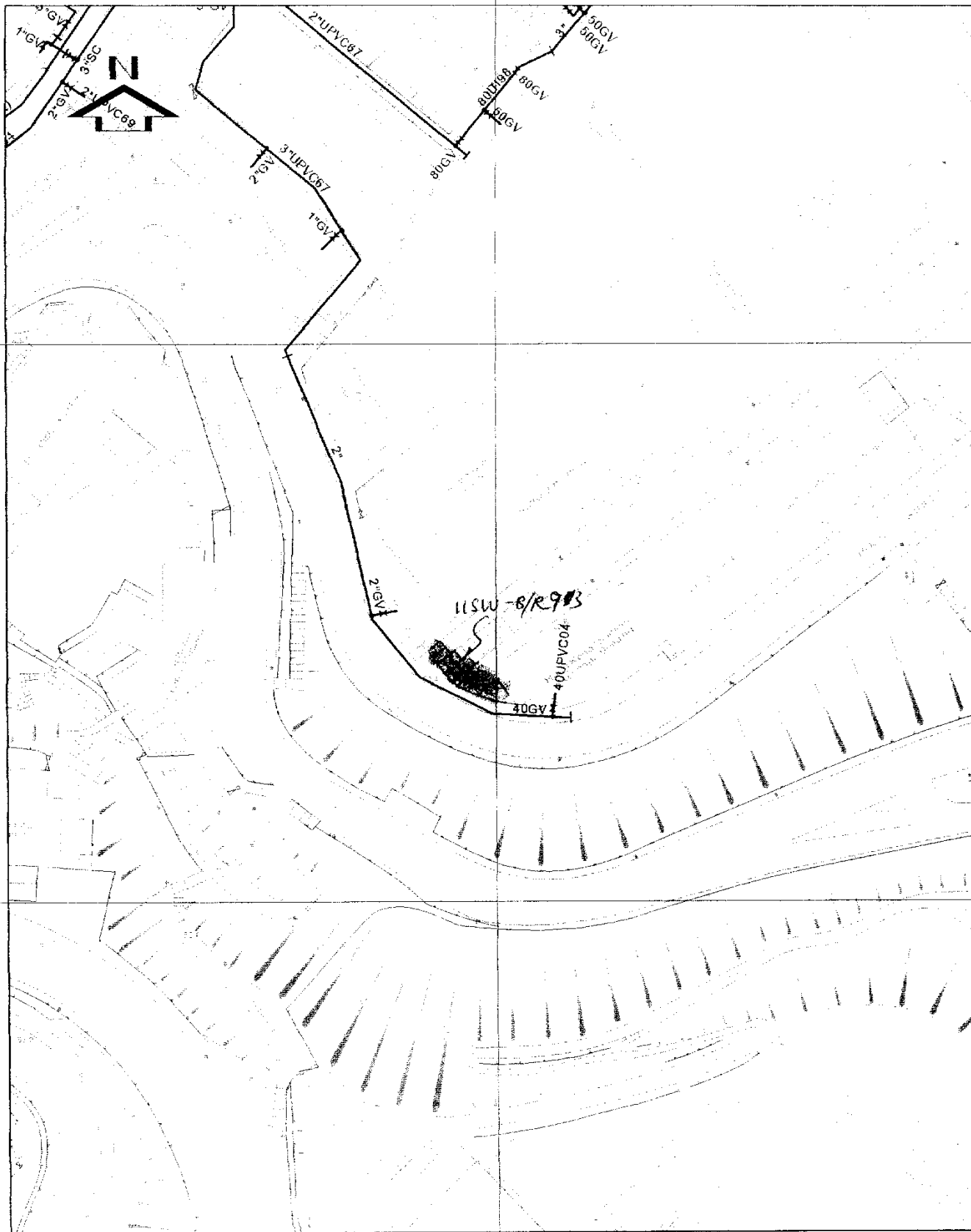

- NOTES:
1. ALL DIMENSIONS ARE IN MILLIMETRES UNLESS OTHERWISE SPECIFIED.
 2. ALL LEVELS ARE IN METRES ABOVE PRINCIPAL DATUM.
 3. INFORMATION ON ALIGNMENT OF MAINS IS OF INDICATIVE VALUE ONLY. WHERE POSITIONAL ACCURACY MAY BE OF IMPORTANCE, DETAILS SHOULD BE SITE CHECKED.
 4. FOR MAINS RECORDS SIGN CONVENTIONS AND DESIGNATIONS. PLEASE REFER TO DRAWING NO. SK 3988A ATTACHED.
 5. NO EXISTING W.S.D. CABLE IN THE VICINITY OF THE SITE.
 6. NO PROPOSED W.S.D. CABLE IN THE VICINITY OF THE SITE.
 7. THE SITE IS NOT WITHIN W.S.D. GATHERING GROUNDS.
 8. NO W.S.D. RESERVE / LAND ALLOCATION WITHIN THE SITE AREA.

PART COPY OF SALT WATER MAINS RECORD PLAN(S)

W67881/11-SW-8D & 13B

FILE REF: (13) IN WSD(HK) /674/2/05TJ1

REF. CODE:40W05M

SHEET 1 OF 1

SCALE 1:1000



水務署
Water Supplies Department



Drainage Services Department
Hong Kong & Islands Division
 42nd floor, Revenue Tower, 5 Gloucester Road,
 Wan Chai, Hong Kong.

渠務署
 香港及離島渠務部
 香港灣仔告士打道5號
 稅務大樓42樓

本署檔號 Our Ref: () in DSD HK *6/5/1/4*
 來函檔號 Your Ref: 24506/GEO/0001ET-LETTER
 電話 Telephone: (852) 2594 7153
 圖文傳真 Fax: (852) 2827 6657

24506	
6-3-4	
14 October, 2005	
Received 14 OCT 2005	
Its.	<i>EL Tam</i>
Action	
Info.	
Copy	

with disc
6/20/10

Ove Arup & Partners Hong Kong Ltd.
 Level 5, Festival Walk
 80 Tat Chee Avenue
 Kowloon Tong, Kowloon
 Hong Kong

Attn.: Elvina Tam

Dear Sirs/Madams,

Agreement No. CE 32/2004 (GE)
Upgrading/Improvement of Roadside Slope/Retaining Walls
on Hong Kong Island (2005 to 2008 Programme)
Investigation, Design and Construction
Request for Existing Utility Information

I refer to your letter dated 04-10-2005 requesting drainage information.

I enclose a CD_Rom containing the drainage information in the vicinity of your proposed works site(s). For those proposed sites not covered by CD_Rom, there is no drainage record kept in this office. Please be reminded that the information given to you should be verified on site and no guarantee can be given that all existing drains/sewers have been included. You are also reminded to return a brand-new CD_Rom to this Office for material exchange.

You are requested to locate your proposed works to be well clear of any existing sewers or stormwater drains. Please exercise extreme care when working in the vicinity of these sewers and drains in order not to disturb, interfere with or cause damage to them. Any damage shall be reported to this Division immediately and shall be made good to DSD's satisfaction at your own cost.

To facilitate the process of your request, you are required to provide the following informations in your future request:-

- i) Co-ordinates of the center of slope.
- ii) Map sheet number corresponding to the 1:1000 map series produced by Lands Department, should be shown on the plan.

Should you have any query on the above, please feel free to contact the undersigned.

Yours faithfully,

Ms P. C. Au Yeung

(Ms P. C. Au Yeung)
 for Chief Engineer/Hong Kong & Islands
 Drainage Services Department

Encl.: CD_Rom

VALUES *信念 樂於承擔 專業精神* *群策群力 竭誠服務*
 Commitment Teamwork
 Professionalism Customer Satisfaction



ISO 9001:2000
 Corporate Certificate No.: HC 012



Drainage Services Department
Hong Kong & Islands Division
 42nd floor, Revenue Tower, 5 Gloucester Road,
 Wan Chai, Hong Kong.

渠務署
香港及離島渠務部
 香港灣仔告士打道5號
 稅務大樓42樓

本署檔號 Our Ref: (140) in DSD HK 6/5/1/4
 來函檔號 Your Ref: 24506/GEO/0002ET-LETTER
 電話 Telephone: (852) 2594 7213
 圖文傳真 Fax: (852) 2827 6657

12 October, 2005

Ove Arup & Partners Hong Kong Ltd.,
 Level 5, Festival Walk
 80 Tat Chee Avenue,
 Kowloon Tong, Hong Kong.

Attn: Mr. Elvina Tam

Dear Sir,

Agreement No. CE32/2004(GE)
Upgrading/Improvement of Roadside Slope/Retaining Walls
on Hong Kong Island (2005 to 2008 Programme)
Request for Existing Utility Information

I refer to your letter of 05.10.2005 requesting for the drainage record.

While your client is affiliated with the Electronic Mark Plant Circulation System, I should be grateful if you would arrange to acquire drainage record drawings through the said system. Nonetheless, please note that alignments and levels of the drains shown on our record drawings are subject to verification on site, I cannot guarantee that all the existing drainage have been incorporated into our record plans. Should the information be of significance to you, you are advised to verify the actual site conditions by means of sub-surface explorations.

You are also advised to exercise extreme care when working in the vicinity of any existing drainage works in order not to disturb, interfere with or cause damage to them. Any blockage or damage to the said works due to your activities in the area shall be made good to my satisfaction at the resources of your project.

Yours faithfully,

REQ NO.	24506
REQ. NO.	6-3-4
Reply Ref.	
Enon Request	
Received	18 OCT 2005
As	<i>Y. P. Au</i>
Position	
NO.	
City	

PA.

(Y. P. AU)
 for Chief Engineer/Hong Kong & Islands
 Drainage Services Department

*will
pls request*

VALUES
 信念 樂於承擔 群策群力
 專業精神 竭誠服務
 Commitment Teamwork
 Professionalism Customer Satisfaction



ISO 9001:2000
 Corporate Certificate No.: HC 012

APPENDIX I

**Services/Utilities
Information provided
by Public and other
Utilities Companies**

香港電燈有限公司
The Hongkong Electric Co., Ltd.



Hongkong Electric Centre, 44 Kennedy Road, Hong Kong
Tel : 2843 3111 Fax : 2810 0506
Website : www.hec.com.hk

Our Ref.: MSD/255/20/02
Your Ref.: 24506/GEO/0001ET-LETTER

19th October 2005

Ove Arup & Partners Hong Kong Ltd.
Level 5, Festival Walk,
80 Tat Chee Avenue,
Kowloon Tong, Kowloon,
Hong Kong

Attn. : Ms. Elvina Tam

Dear Ms. Tam,

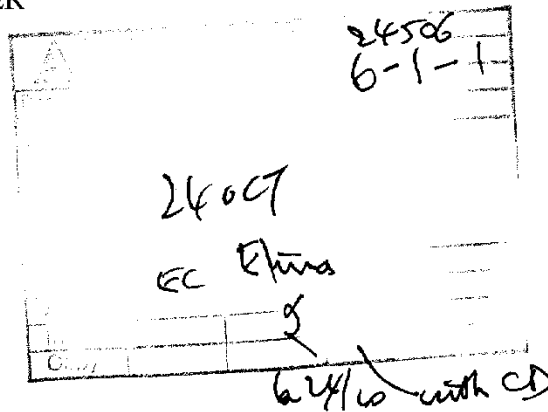

AGREEMENT NO. CE32/2004 (GE)
UPGRADING/ IMPROVEMENT OF ROADSIDE SLOPE/ RETAINING WALLS
ON HONG KONG ISLAND (2005 TO 2008 PROGRAMME)
INVESTIGATION, DESIGN AND CONSTRUCTION
REQUEST FOR EXISTING UTILITY INFORMATION

We refer to your letter dated 4th October 2005 informing us of your impending works at various locations.

Enclosed is a compact disk containing part plans in pdf format showing the approximate positions of this Company's electricity supply lines in the vicinity of your proposed works. *A table of content about the CD is also enclosed for your easy reference.* These plans are intended for use by you and your authorized contractors/employees only for the sole purpose set out in your letter. The Company shall not be liable for any loss or damage of whatever nature caused to any third parties as a result of their relying on the information given therein. Please note that the plans showed the record of our electricity supply lines at the time the plans were prepared. Also enclosed are part plans in pdf format showing the approximate locations where our Company's new cables are being laid or planned to be laid. Please note that the new cable installation proposals are subject to changes without prior notice and they are for information only without committing our Company to inform you of any changes which may be made from time to time. Further information can be obtained from our Mr. W.H. Lee at telephone No. 2843 3161. In case the whole or part of your proposed works would not be carried out shortly, you should contact us again for updated plans towards the time of actual site work implementation.

If our electricity supply lines are in any way damaged in the course of, or as a result of your works, we shall hold you fully responsible and liable for all costs incurred and for any claims from third parties for any loss or damage of whatsoever nature including damage to property, death, personal injury, loss caused by delay and/or inconvenience and/or consequential loss of any kind caused by or in any way associated with the damage. Should such incidents occur, it is imperative that you stop your works, keep away from the spot, guard the site and report to us at telephone No. 2555 4999 or 2555 4000 immediately.

/To be continued.....

Since our cables are energised and our enclosed plans show only their approximate, rather than exact, positions, it is imperative that your contractors and employees exercise extreme care during any works that may be required and take all necessary steps and measures to prevent accidents to personnel and to our electricity supply lines as stipulated in the Code of Practice on Working near Electricity Supply Lines issued in accordance with the provision of the Electricity Supply Lines (Protection) Regulation under the Electricity Ordinance (Cap. 406) by Electrical and Mechanical Services Department. We enclose a copy of our "**General Practice on Execution of Excavation and Construction Work Near Underground Electricity Cables**" (the General Practice) for your guidance. You are required to read through the General Practice carefully and follow the guidelines thoroughly in the course of your works. **Remember cables when damaged and joints if improperly handled may explode and cause death or injury to your employees or the general public and may lead to a suspension of our supply of electricity to many domestic, commercial and industrial users.** We also enclose a pamphlet showing the precautionary measures for working close to our cables for your attention.

In case temporary support of our underground electricity cables is necessary for facilitating your works, you are required to support our cables complying with the requirements as stated in item 2 of the "General Practice on Execution of Excavation and Construction Work Near Underground Electricity Cables" and inform us at telephone No. 2814 3443 to arrange an inspection on your temporary supports before you proceed with your works.

In case any of our underground electricity cables are required to be diverted or shifted to facilitate your works, please inform our Mr. W.H. Lee at telephone No. 2843 3161 of the details well in advance so that appropriate action can be taken by this Company.

For works that are undertaken in close proximity to our 132 kV cables you are required to contact us at telephone No. 2814 3443 giving the name of your full time supervisor and contact telephone number to us. Please note that the requirements as stated in item 3 of the "General Practice on Execution of Excavation and Construction Work Near Underground Electricity Cables" should be strictly observed. Please be informed that the 132 kV cables are very important circuits affecting a large number of customers. Any disturbance and diversion of these circuits would affect the security of electricity supply to our customers and cause major disturbance to the public. Therefore, the diversion or joint relocation of these cables should be avoided as far as practicable. Under the exceptional circumstance where there is no other alternative but diversion or joint relocation, we would require at least 12 months lead time to enable us to obtain the necessary materials for the diversion work.

Please contact our Senior Support Engineer, Mr. K.C. Wong at telephone No. 2814 6036 to coordinate a meeting to discuss your working methods in order to avoid any inadvertent damage to our 132 kV cable circuits.

Should you intend to install any of your plant/equipment in proximity to our 132 kV cables and other types of cables, a minimum clearance of 1000mm and 300mm respectively must be maintained.

For information regarding the Street Lighting cables, please contact Cavendish Construction Limited at telephone number 3102 2284, CCL Shaukeiwan Depot, Lot No. THK 1471, Oi Lai Street, Shaukeiwan, Hong Kong.

Yours sincerely,



B. W. Lo

DISTRIBUTION PLANNING MANAGER

Encl. Content of CD

MPC-J05449981-001-R-HEC-01.pdf, MPC-J05449981-002-R-HEC-01.pdf
MPC-J05449981-003-R-HEC-01.pdf, MPC-J05449981-004-R-HEC-01.pdf
MPC-J05449981-005-R-HEC-01.pdf, MPC-J05449981-006-R-HEC-01.pdf
MPC-J05449981-007-R-HEC-01.pdf, MPC-J05449981-008-R-HEC-01.pdf
MPC-J05449981-009-R-HEC-01.pdf, MPC-J05449981-010-R-HEC-01.pdf
MPC-J05449981-011-R-HEC-01.pdf, MPC-J05449981-012-R-HEC-01.pdf
MPC-J05449981-013-R-HEC-01.pdf, MPC-J05449981-014-R-HEC-01.pdf
MPC-J05449981-015-R-HEC-01.pdf, MPC-J05449981-016-R-HEC-01.pdf
MPC-J05449981-017-R-HEC-01.pdf, MPC-J05449981-018-R-HEC-01.pdf
MPC-J05449981-019-R-HEC-01.pdf, MPC-J05449981-020-R-HEC-01.pdf
MPC-J05449981-021-R-HEC-01.pdf

WYW/

香港電燈有限公司
The Hongkong Electric Co., Ltd.



Hongkong Electric Centre, 44 Kennedy Road, Hong Kong
 Tel : 2843 3111 Fax : 2810 0506
 Website : www.hec.com.hk

Our Ref.: MSD/255/20/02
 Your Ref.: 24506/GEO/0002ET-LETTER

Ove Arup & Partners Hong Kong Ltd.
 Level 5, Festival Walk,
 80 Tat Chee Avenue,
 Kowloon Tong, Kowloon,
 Hong Kong

Attn. : Mr. Elvina Tam

Dear Mr. Tam,

24506

ARUP		Date: 17 th October 2005	
Reply Ref.:		Page: 6-1-1	
Action Required:			
Received 20 OCT 2005			
Initia.	ec	Alvina	
Action			
Info.			
Copy			

6/20/10

AGREEMENT NO. CE32/2004 (GE)
UPGRADING/IMPROVEMENT OF ROADSIDE SLOPE/RETAINING WALLS
ON HONG KONG ISLAND (2005 TO 2008 PROGRAMME)
INVESTIGATION, DESIGN AND CONSTRUCTION
REQUEST FOR EXISTING UTILITY INFORMATION

We refer to your letter dated 5th October 2005 informing us of your impending works at various locations.

Enclosed are part plans showing the approximate positions of this Company's electricity supply lines in the vicinity of your proposed works. These plans are intended for use by you and your authorized contractors/employees only for the sole purpose set out in your letter. The Company shall not be liable for any loss or damage of whatever nature caused to any third parties as a result of their relying on the information given therein. Please note that the plans showed the record of our electricity supply lines at the time the plans were prepared. Also enclosed is a part plan showing the approximate locations where our Company's new cables are being laid or planned to be laid. Please note that the new cable installation proposals are subject to changes without prior notice and they are for information only without committing our Company to inform you of any changes which may be made from time to time. Further information can be obtained from our Mr. C.K. Lau at telephone No. 2843 3115. In case the whole or part of your proposed works would not be carried out shortly, you should contact us again for updated plans towards the time of actual site work implementation.

If our electricity supply lines are in any way damaged in the course of, or as a result of your works, we shall hold you fully responsible and liable for all costs incurred and for any claims from third parties for any loss or damage of whatsoever nature including damage to property, death, personal injury, loss caused by delay and/or inconvenience and/or consequential loss of any kind caused by or in any way associated with the damage. Should such incidents occur, it is imperative that you stop your works, keep away from the spot, guard the site and report to us at telephone No. 2555 4999 or 2555 4000 immediately.

/To be continued.....

Since our cables are energised and our enclosed plans show only their approximate, rather than exact, positions, it is imperative that your contractors and employees exercise extreme care during any works that may be required and take all necessary steps and measures to prevent accidents to personnel and to our electricity supply lines as stipulated in the Code of Practice on Working near Electricity Supply Lines issued in accordance with the provision of the Electricity Supply Lines (Protection) Regulation under the Electricity Ordinance (Cap. 406) by Electrical and Mechanical Services Department. We enclose a copy of our **"General Practice on Execution of Excavation and Construction Work Near Underground Electricity Cables"** (the General Practice) for your guidance. You are required to read through the General Practice carefully and follow the guidelines thoroughly in the course of your works. **Remember cables when damaged and joints if improperly handled may explode and cause death or injury to your employees or the general public and may lead to a suspension of our supply of electricity to many domestic, commercial and industrial users.** We also enclose a pamphlet showing the precautionary measures for working close to our cables for your attention.

In case temporary support of our underground electricity cables is necessary for facilitating your works, you are required to support our cables complying with the requirements as stated in item 2 of the "General Practice on Execution of Excavation and Construction Work Near Underground Electricity Cables" and inform us at telephone No. 2814 3443 to arrange an inspection on your temporary supports before you proceed with your works.

In case any of our underground electricity cables are required to be diverted or shifted to facilitate your works, please inform our Mr. C.K. Lau at telephone No. 2843 3115 of the details well in advance so that appropriate action can be taken by this Company.

Should you intend to install any of your plant/equipment in proximity to our cables, a minimum clearance of 300mm must be maintained.

For information regarding the Street Lighting cables, please contact Cavendish Construction Limited at telephone number 3102 2284, CCL Shaukeiwan Depot, Lot No. THK 1471, Oi Lai Street, Shaukeiwan, Hong Kong.

Yours sincerely,



T. C. Lee

SENIOR DISTRIBUTION PLANNING ENGINEER

Encl. J05450510-001 (HV, LV, PT, EA)
J05450510-002 (HV, LV, PT, EA)
J05450510-003 (HV, LV, PT, EA)
J05450510-004 (HV, LV, PT, EA)

CML/

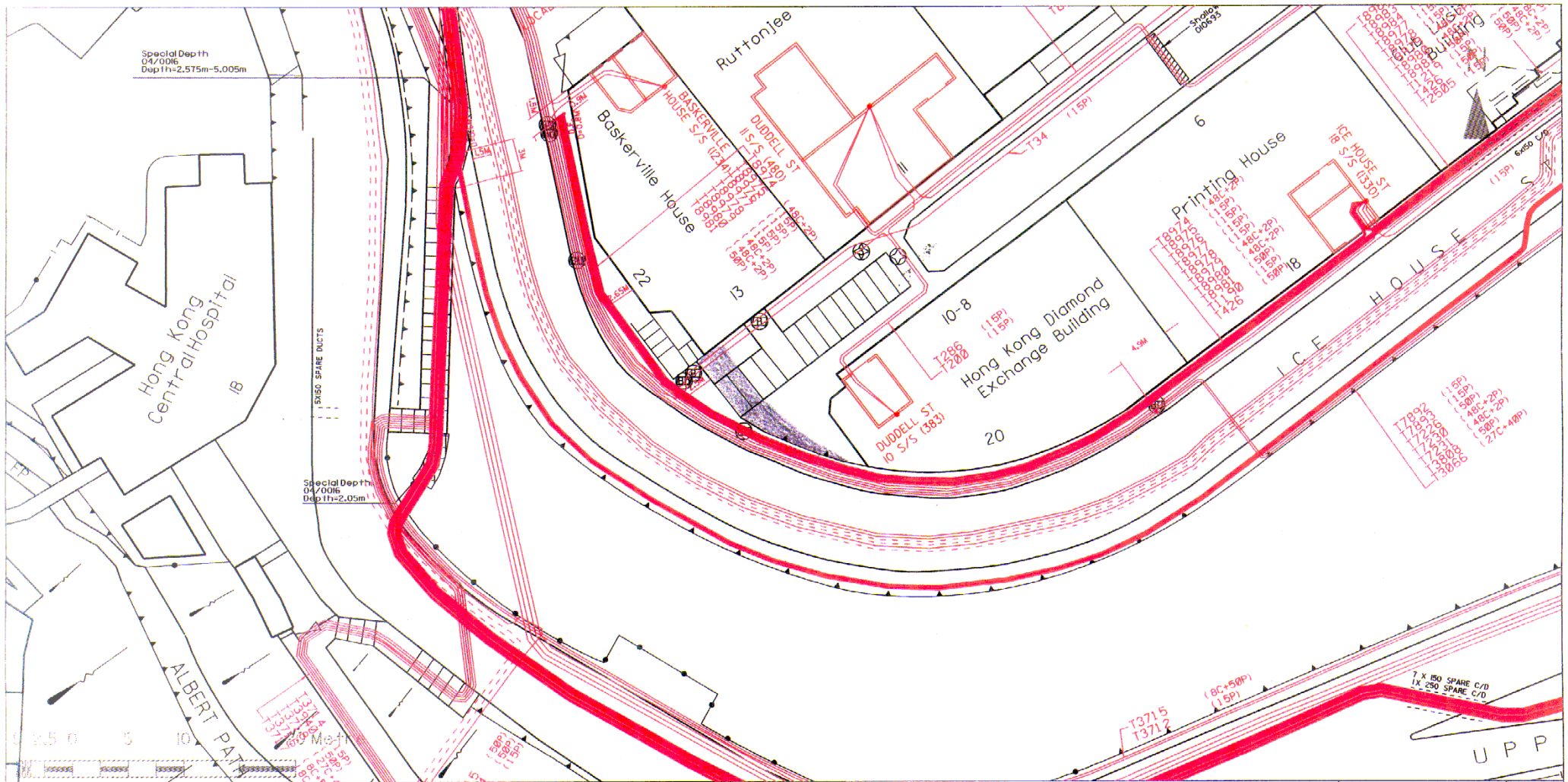

Notes:

- THE ELECTRICITY SUPPLY LINES (ESL) SHOWN ON THE PLAN ARE APPROXIMATE ONLY. WHEN WORKS ARE TAKEN IN VICINITY OF THESE ESL, YOU ARE REMINDED TO TAKE ALL NECESSARY STEPS AND MEASURES AS STIPULATED IN THE CODE OF PRACTICE ON WORKING NEAR ESL ISSUED BY EMSD.
- THIS PLAN SHOULD BE READ IN CONJUNCTION WITH ITEM 4 OF OUR 'GENERAL PRACTICE ON EXECUTION OF EXCAVATION AND CONSTRUCTION WORK NEAR UNDERGROUND ELECTRICITY CABLES', HCC CABLES WHICH ARE MORE PRONE TO SHALLOW COVER MAY BE FOUND AT THE MATCHED AREA MARKED WITH 'SHALLOW COVER' AND AT ITS VICINITY AREAS.
- FOR THE SAKE OF SAFETY, WHEN YOUR WORKS ARE UNDERTAKEN IN CLOSE PROXIMITY TO THE TYPES OF CABLE JOINT MARKED BY (S) OR (J), YOU MUST INFORM HCC AT TELEPHONE 28143443 TO ARRANGE INSPECTION AND NECESSARY ACTION BEFORE COMMENCING SUCH WORKS.
- FOR WORKS THAT ARE UNDERTAKEN IN CLOSE PROXIMITY TO OUR 275/132/66KV CABLES OR JOINTS OR 132KV O/H LINES, YOU ARE REQUIRED TO CONTACT THE RESPONSIBLE ENGINEER IN OUR CONSTRUCTION & MAINTENANCE DEPARTMENT, T & D DIVISION BEFORE COMMENCING SUCH WORKS.
- CONFIDENTIAL: EXCEPT FOR YOUR AUTHORIZED CONTRACTORS/EMPLOYEES, THIS DRAWING MUST NOT BE RELEASED TO THIRD PARTY WITHOUT HCC'S WRITTEN APPROVAL.

備註:

- 此圖只顯示供電電纜之大致位置。當在該等供電電纜附近進行工程時，請切記遵守由機電工程署所發備之有關在供電電纜附近工作的實務守則。
- 此圖應連同本公司的「在地下電纜附近進行挖掘及建造工程的一般守則」第四項一起參閱。在註有「SHALLOW COVER」標記之影響範圍及其附近的位置可能會遇到某些位於離地面較近之本公司電纜。
- 為了安全理由，在圖中註有(S)或(J)標記之接線箱附近進行工程前，請先與28143443知會本公司安排檢查及進行有需要之工程。
- 在本公司275/132/66 kV供電電纜或接線箱或132 kV架空導線附近進行工程前，請先與本公司輸配電科工程師連繫及發覺部之負責工程師聯絡。
- 警告：此圖在未有本公司圖面授權下，只給供給閣下之報員/指定承建商使用。

AMH0TH Map No.: 11SW08D4

22KV/SOLKOR CABLE ROUTE
22 kV / 纜電供電電纜路線
22KV/SOLKOR RESERVED CABLE ROUTE
22 kV / 纜電供電備用電纜路線
22KV/SOLKOR CABLE JOINT
22 kV / 纜電供電電纜接線箱
22KV/SOLKOR CABLE TERMINATOR
22 kV / 纜電供電電纜終端

11KV CABLE ROUTE
11 kV 電纜路線
11KV RESERVED CABLE ROUTE
11 kV 備用電纜路線
11KV CABLE JOINT
11 kV 電纜接線箱
11KV CABLE TERMINATOR
11 kV 電纜終端

UNDERGROUND ELECTRICITY CABLES MAY BE BURIED AT DEPTH LESS THAN THE MINIMUM COVER REQUIREMENT AS STIPULATED IN THE CONDITIONS OF EXCAVATION PERMIT ISSUED BY HIGHWAYS DEPARTMENT.
地下電纜可能埋藏於較路政署發出之挖掘准許證上所列之最少埋藏深度為少。

SHALLOW COVER

LOW VOLTAGE CABLE ROUTE
低壓電纜路線
LOW VOLTAGE RESERVED CABLE ROUTE
低壓備用電纜路線
LOW VOLTAGE O/H LINE ROUTE
低壓架空導線路線
LOW VOLTAGE CABLE JOINT
低壓電纜接線箱
LOW VOLTAGE CABLE TERMINATOR
低壓電纜終端

FIBRE OPTIC/PILOT CABLE ROUTE
光纖/導引電纜路線
FIBRE OPTIC/PILOT RESERVED CABLE ROUTE
光纖/導引備用電纜路線
FIBRE OPTIC/PILOT CABLE JOINT
光纖/導引電纜接線箱
FIBRE OPTIC/PILOT CABLE TERMINATOR
光纖/導引電纜終端

T/PTXXXX
T/PTXXXX
T/PTXXXX
T/PTXXXX
T/PTXXXX

MAP DATA IS REPRODUCED WITH THE PERMISSION OF THE GOVERNMENT OF HKSAR. © GOVERNMENT OF HKSAR

11SW-0/R33

RATING/TYPE 額定值/類別	NEW CABLE COLOUR 新線顏色	OUTER DIAMETER (mm) 外層直徑(毫米)
22KV CABLE 22 kV 電纜	TURBOUISE 綠藍	43-48
11KV CABLE 11 kV 電纜	RED, TURBOUISE OR BLACK 紅, 綠藍或黑	50-98
LOW VOLTAGE CABLE 低壓電纜	GREEN, BLUE OR BLACK 綠, 藍或黑	25-85
FIBRE OPTIC/PILOT CABLE 光纖/導引電纜	YELLOW, PINK OR BLACK 黃, 粉紅或黑	25-63
SOLKOR CABLE 纜電供電電纜	TURBOUISE 綠藍	35-39

Ref. No.: J05449981-009
Date: 19/10/2005

Scale: 1:500
as printed on A4 size paper

香港電燈有限公司
The Hongkong Electric Co., Ltd
Management Services Division
Distribution Planning

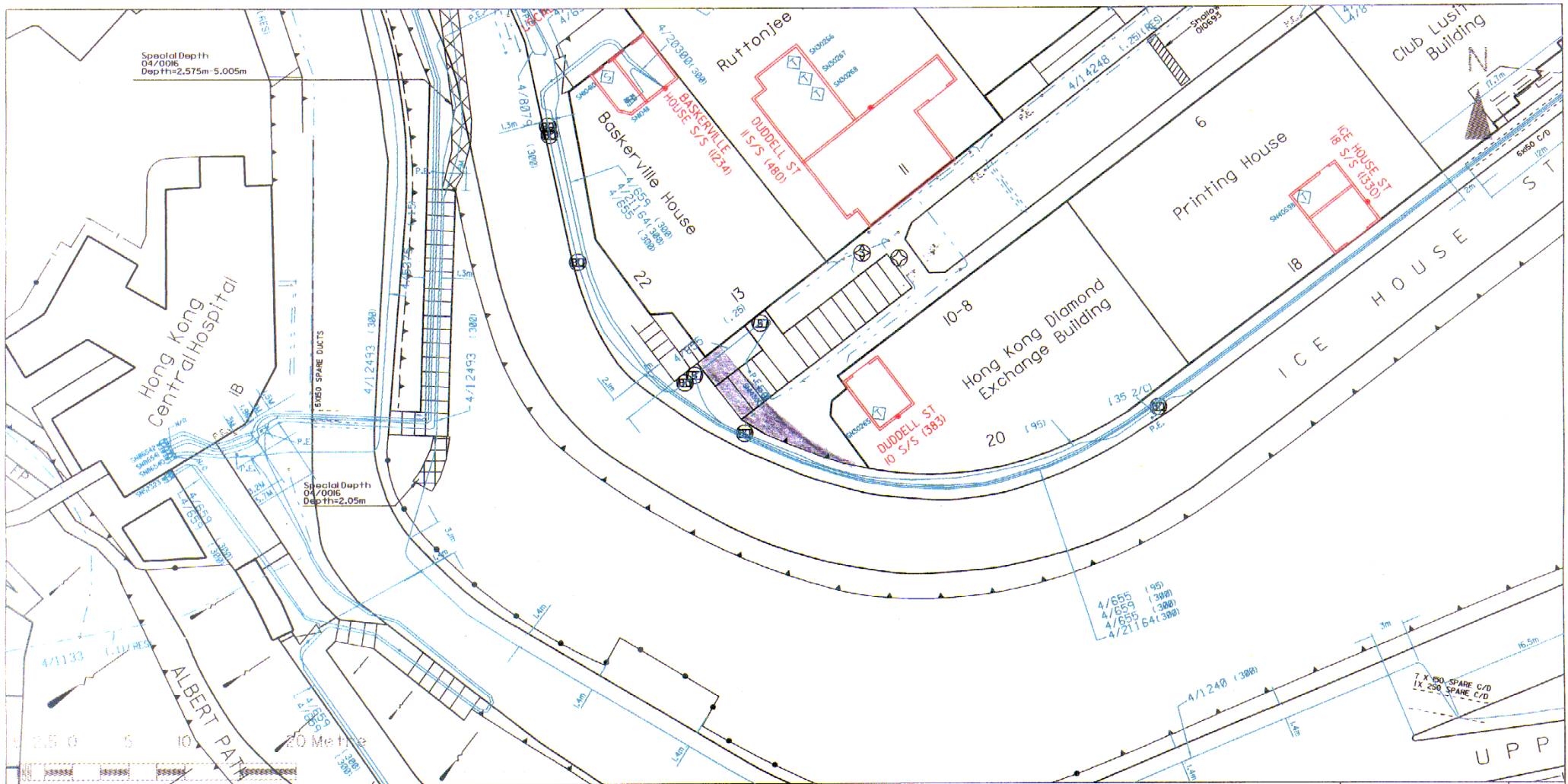

Notes:

- THE ELECTRICITY SUPPLY LINES (ESL) SHOWN ON THE PLAN ARE APPROXIMATE ONLY. WHEN WORKS ARE TAKEN IN VICINITY OF THESE ESL, YOU ARE REMINDED TO TAKE ALL NECESSARY STEPS AND MEASURES AS STIPULATED IN THE CODE OF PRACTICE ON WORKING NEAR ESL ISSUED BY EMSD.
- THIS PLAN SHOULD BE READ IN CONJUNCTION WITH ITEM 4 OF OUR 'GENERAL PRACTICE ON EXECUTION OF EXCAVATION AND CONSTRUCTION WORK NEAR UNDERGROUND ELECTRICITY CABLES, HEC CABLES WHICH ARE MORE PRONE TO SHALLOW COVER MAY BE FOUND AT THE HATCHED AREA MARKED WITH 'SHALLOW COVER' AND AT ITS VICINITY AREAS.
- FOR THE SAKE OF SAFETY, WHEN YOUR WORKS ARE UNDERTAKEN IN CLOSE PROXIMITY TO THE TYPES OF CABLE JOINT MARKED BY (S) OR (T), YOU MUST INFORM HEC AT TELEPHONE 28143443 TO ARRANGE INSPECTION AND NECESSARY ACTION BEFORE COMMENCING SUCH WORKS.
- FOR WORKS THAT ARE UNDERTAKEN IN CLOSE PROXIMITY TO OUR 275/132/66KV CABLES OR JOINTS OR 132KV O/H LINES, YOU ARE REQUIRED TO CONTACT THE RESPONSIBLE ENGINEER IN OUR CONSTRUCTION & MAINTENANCE DEPARTMENT, T & D DIVISION BEFORE COMMENCING SUCH WORKS.
- CONFIDENTIAL: EXCEPT FOR YOUR AUTHORIZED CONTRACTORS/EMPLOYEES, THIS DRAWING MUST NOT BE RELEASED TO THIRD PARTY WITHOUT HEC'S WRITTEN APPROVAL.

備註:

- 此圖只顯示供電電纜之大致位置。當在該等供電電纜附近進行工程時，請切記遵守由機電工程署所頒佈之有關供電電纜附近工作的實務守則。
- 此圖應與向本公司的「在地下電纜附近進行挖掘及建造工程的一般守則」第四項一起參閱。在註有 'SHALLOW COVER' 標記之影響範圍及其附近的位置可能會遇到某些位於離地面較近之本公司電纜。
- 為了安全理由，在圖中註有 (S) 或 (T) 標記之接線箱附近進行工程前，請先撥 28143443 知會本公司安排檢查及進行有需要之工程。
- 在本公司 275/132/66 千伏電纜或接線箱或 132 千伏架空線附近進行工程前，請先與本公司檢閱電料工程建築及保養部之負責工程師聯絡。
- 備註：此圖在未有本公司書面授權下，只能供相關之下屬員工/指定承辦商使用。

A4H0TH Map No.: 11SW0804

22KV/SOLKOR CABLE ROUTE 22 千伏 / 纜電線電纜路線	4/XXXXX 4/XXXXX	LOW VOLTAGE CABLE ROUTE 低壓電纜路線
22KV/SOLKOR RESERVED CABLE ROUTE 22 千伏 / 纜電線預備用電纜路線	4/XXXXX 4/XXXXX	LOW VOLTAGE RESERVED CABLE ROUTE 低壓預備用電纜路線
22KV/SOLKOR CABLE JOINT 22 千伏 / 纜電線電纜接線箱	ABC ABC	LOW VOLTAGE O/H LINE ROUTE 低壓架空線纜路線
22KV/SOLKOR CABLE TERMINATOR 22 千伏 / 纜電線電纜終端	4/XXXXX 4/XXXXX	LOW VOLTAGE CABLE JOINT 低壓電纜接線箱
11KV CABLE ROUTE 11 千伏電纜路線	4/XXXXX 4/XXXXX	LOW VOLTAGE CABLE TERMINATOR 低壓電纜終端
11KV RESERVED CABLE ROUTE 11 千伏預備用電纜路線	4/XXXXX 4/XXXXX	FIBRE OPTIC/PILOT CABLE ROUTE 光纖 / 導引電纜路線
11KV CABLE JOINT 11 千伏電纜接線箱	4/XXXXX 4/XXXXX	FIBRE OPTIC/PILOT RESERVED CABLE ROUTE 光纖 / 導引預備用電纜路線
11KV CABLE TERMINATOR 11 千伏電纜終端	4/XXXXX 4/XXXXX	FIBRE OPTIC/PILOT CABLE JOINT 光纖 / 導引電纜接線箱
UNDERGROUND ELECTRICITY CABLES MAY BE BURIED AT DEPTH LESS THAN THE MINIMUM COVER REQUIREMENT AS STIPULATED IN THE CONDITIONS OF EXCAVATION PERMIT ISSUED BY HIGHWAYS DEPARTMENT. 地下電纜可能埋藏於較路政署發出之挖掘准許證上所規定之最少覆蓋厚度為少。	4/XXXXX 4/XXXXX	FIBRE OPTIC/PILOT CABLE TERMINATOR 光纖 / 導引電纜終端

SHALLOW COVER

MAP DATA IS REPRODUCED WITH THE PERMISSION OF THE GOVERNMENT OF HKSAR. © GOVERNMENT OF HKSAR

11SW-8/1993

Grid Position : X:l Y:l	Rev. 01	
RATING/TYPE 額定額 / 類別	NEW CABLE COLOUR 新纜顏色	OUTER DIAMETER (mm) 外圍直徑 (毫米)
22KV CABLE 22 千伏電纜	TURQUOISE 綠藍	43-98
11KV CABLE 11 千伏電纜	RED, TURQUOISE OR BLACK 紅, 綠藍或黑	50-98
LOW VOLTAGE CABLE 低壓電纜	GREEN, BLUE OR BLACK 綠, 藍或黑	25-85
FIBRE OPTIC/PILOT CABLE 光纖 / 導引電纜	YELLOW, PINK OR BLACK 黃, 粉紅或黑	25-63
SOLKOR CABLE 纜電線電纜	TURQUOISE 綠藍	35-39
Ref. No.: J05449981-009	Scale: 1:500	
Date: 19/10/2005	as printed on A4 size paper	
香港電燈有限公司 The Hongkong Electric Co., Ltd Management Services Division Distribution Planning		



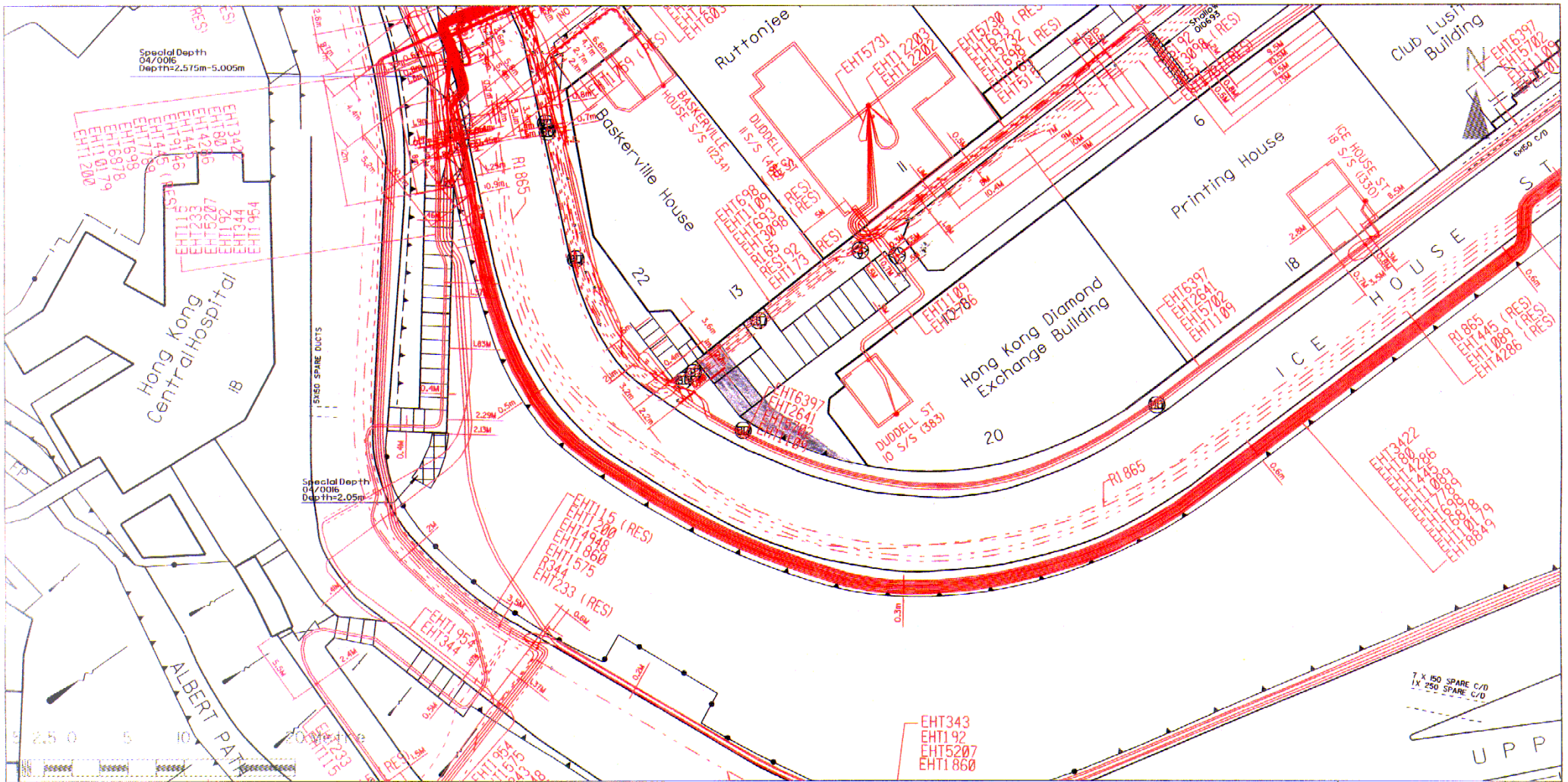

Notes

1. THE ELECTRICITY SUPPLY LINES (RES) SHOWN ON THE PLAN ARE APPROXIMATE ONLY. WHEN WORKS ARE TAKEN IN VICINITY OF THESE ES, YOU ARE REMINDED TO TAKE ALL NECESSARY STEPS AND MEASURES AS STIPULATED IN THE CODE OF PRACTICE ON WORKING NEAR ES, ISSUED BY FMSD.
2. THIS PLAN SHOULD BE READ IN CONJUNCTION WITH ITEM 4 OF OUR GENERAL PRACTICE ON EXECUTION OF EXCAVATION AND CONSTRUCTION WORK NEAR UNDERGROUND ELECTRICITY CABLES. THE CABLES WHICH ARE MORE PRONE TO SHALLOW COVER MAY BE FOUND AT THE HATCHED AREA MARKED WITH 'SHALLOW COVER' AND AT ITS VICINITY AREAS.
3. FOR THE SAKE OF SAFETY, WHEN YOUR WORKS ARE UNDERTAKEN IN CLOSE PROXIMITY TO THE TYPES OF CABLE JOINT MARKED BY (S) OR (C), YOU MUST INFORM HELI AT TELEPHONE 28143443 TO ARRANGE INSPECTION AND NECESSARY ACTION BEFORE COMMENCING SUCH WORKS.
4. FOR WORKS THAT ARE UNDERTAKEN IN CLOSE PROXIMITY TO OUR 275/132/66KV CABLES OR JOINTS OR 132KV O/H LINES, YOU ARE REQUIRED TO CONTACT THE RESPONSIBLE ENGINEER IN OUR CONSTRUCTION & MAINTENANCE DEPARTMENT, I & D DIVISION BEFORE COMMENCING SUCH WORKS.
5. CONFIDENTIAL: EXCEPT FOR YOUR AUTHORIZED CONTRACTORS/EMPLOYEES, THIS DRAWING MUST NOT BE RELEASED TO THIRD PARTY WITHOUT HELI'S WRITTEN APPROVAL.

備註

1. 此圖只顯示供電電纜之大致位置。當在該等供電電纜附近進行工程時，請切記遵守由機電工程署所擬備之有關在供電電纜附近工作的實務守則。
2. 此圖應連同本公司的「在地下電纜附近進行挖掘及建造工程的一般守則」第四項一起閱讀。在註有「SHALLOW COVER」標記之影響範圍及在其附近的位置可能會遇到某些位於離地面較近之本公司電纜。
3. 為了安全理由，在圖中註有(S)或(C)標記之接線箱附近進行工程時，請先與 28143443 知會本公司安排檢查及進行必要之工程。
4. 在本公司 275/132/66 千伏電纜或接線箱或 132 千伏架空導線附近進行工程時，請先與本公司輸電電工工程處及負責區之負責工程師聯絡。
5. 保密：此圖在未獲本公司書面授權下，只能供給圖下之僱員/指定承辦商使用。

A4H01H Map No.: 11SW08D4

EHTYYYYY(22KV) S0KYYYY	22KV/SOLKDR CABLE ROUTE 22千伏/纜電保線電纜路線
EHTYYYYY(22KV) S0KYYYY	22KV/SOLKDR RESERVED CABLE ROUTE 22千伏/纜電保線備用電纜路線
EHTYYYYY(22KV) S0KYYYY	22KV/SOLKDR CABLE JOINT 22千伏/纜電保線電纜接線箱
EHTYYYYY(22KV) S0KYYYY	22KV/SOLKDR CABLE TERMINATOR 22千伏/纜電保線電纜終端
EHTXXXXX EHTXXXXX	11KV CABLE ROUTE 11千伏電纜路線
EHTXXXXX EHTXXXXX	11KV RESERVED CABLE ROUTE 11千伏備用電纜路線
EHTXXXXX EHTXXXXX	11KV CABLE JOINT 11千伏電纜接線箱
EHTXXXXX EHTXXXXX	C.E. 11KV CABLE TERMINATOR C.E. 11千伏電纜終端

SHALLOW COVER

UNDERGROUND ELECTRICITY CABLES MAY BE BURIED AT DEPTH LESS THAN THE MINIMUM COVER REQUIREMENT AS STIPULATED IN THE CONDITIONS OF EXCAVATION PERMIT ISSUED BY HIGHWAYS DEPARTMENT.
地下電纜可能埋藏於較路政署發出之挖掘准許證上所規定的最少覆蓋層厚度為少。

LOW VOLTAGE CABLE ROUTE 低壓電纜路線	LOW VOLTAGE RESERVED CABLE ROUTE 低壓備用電纜路線	LOW VOLTAGE O/H LINE ROUTE 低壓架空導線路線	LOW VOLTAGE CABLE JOINT 低壓電纜接線箱	LOW VOLTAGE CABLE TERMINATOR 低壓電纜終端
FIBRE OPTIC/PILOT CABLE ROUTE 光纖/導引電纜路線	FIBRE OPTIC/PILOT RESERVED CABLE ROUTE 光纖/導引備用電纜路線	FIBRE OPTIC/PILOT CABLE JOINT 光纖/導引電纜接線箱	FIBRE OPTIC/PILOT CABLE TERMINATOR 光纖/導引電纜終端	

MAP DATA IS REPRODUCED WITH THE PERMISSION OF THE GOVERNMENT OF HKSAR. © GOVERNMENT OF HKSAR

11SW-B/1893

Grid Position : X:1 Y:1		Rev. 01
RATING/TYPE 額定值/類別	NEW CABLE COLOUR 新線顏色	OUTER DIAMETER (mm) 外圍直徑(毫米)
22KV CABLE 22千伏電纜	TURQUOISE 綠藍	43-98
11KV CABLE 11千伏電纜	RED, TURQUOISE OR BLACK 紅, 綠藍或黑	58-98
LOW VOLTAGE CABLE 低壓電纜	GREEN, BLUE OR BLACK 綠, 藍或黑	25-85
FIBRE OPTIC/PILOT CABLE 光纖/導引電纜	YELLOW, PINK OR BLACK 黃, 粉紅或黑	25-63
SOLKDR CABLE 纜電保線電纜	TURQUOISE 綠藍	35-39
Ref. No.: J05449981-009	Scale: 1:500	
Date: 19/10/2005	as printed on A4 size paper	
香港電燈有限公司 The Hongkong Electric Co., Ltd Management Services Division Distribution Planning		



Towngas

The Hong Kong and China Gas Company Limited

21 October 2005

Your Ref.: 24506/GEO/0001ET-LETTER

Our Ref.: UNE2005/10471/I

Ove Arup & Partners
Level 5, Festival Walk,
80 Tat Chee Avenue,
Kowloon Tong,
Kowloon.

Attn.: Ms Elvina Tam

**In view of safety, HKCG provides
FREE service to assist the road
opening parties to locate the
approximate gas pipe alignment
on site, Please call 29631811
before work starts.**

Dear Sirs

**Re: Agreement No. CE32/2004 (GE), Upgrading/Improvement of Roadside
Slope/Retaining Walls on Hong Kong Island (2005 to 2008 Programme),
Investigation, Design and Construction, Request for Existing Utility Information**

We received your letter of 04 October 2005 requesting drawings on the location of Towngas pipelines. We are attaching the drawings for the location of existing/proposed pipelines that you requested. These drawings are only approximate. The pipes may be located in different positions and depths due to continual road development, system alterations and underground obstructions. Therefore, the exact location may be altered from point to point. There is the possibility that some gas pipes particularly those laid long time ago or laid by other Registered Gas Contractors may not appear in our records. In the case of some unknown pipes being exposed during your construction work, please contact us immediately.

We suggest that you do not work too close to the pipes as any damage to them could create a hazardous accident. You should be very careful when excavating the area. You should locate the exact position and depth of the pipes by making a series of hand-dug trial holes. Heavy machinery such as drills or mechanical excavators cannot be used to do this. If your company damages our pipelines, you will be responsible for all resultant costs.

We would also like to remind you not to disturb any part of Towngas pipeline or their associated properties and not to temporarily or permanently encase part or all of our gas pipes in any form of concrete structures. Please provide steel gas pipes a clearance of 600mm and other gas pipes a clearance of 300mm. This space is necessary for future maintenance.

24506
6-1-2

BC *Alvin* *K* *Chiu* *6-1-2*

If your work involves construction of new manholes or performing operation in existing manholes, we recommend sealing off all the duct openings in new/existing manholes, to avoid accumulation of hazardous gas in manholes, which might create a dangerous explosive environment.

If you want to divert gas pipes, we must have at least two months and six months notice respectively for distribution and transmission networks before commencing our planning works. Your company will be responsible for the full cost of any diversion. A written agreement will be required before we begin any diversion.

SAFETY:

1. If a gas pipe is damaged or a leak is suspected, phone the Emergency Services Hotline, 28806999, immediately. Also, keep all ignition sources away from the site.
2. Cigarette smoking is prohibited when working near the pipelines.
3. In case of a leak, stop work, evacuate all employees and the public from the area.
4. Construction activities require naked fire must not be applied within 3 meters proximity of exposed gas pipes without prior approval under proper management procedures, such as permit to work, etc.

Please contact Mr Chan Yuen Lok on 2963 1811 to arrange for a joint site inspection regarding the pipe location. Further, you must notify us at least one week before beginning work on site. For enquiry of proposed pipeline, if any, or availability of gas supply, please contact Mr Y L Lau on 2963 1830.

Yours faithfully

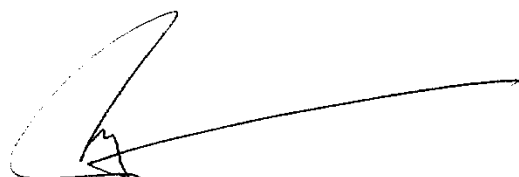

^{R²} Albert C K Leung
System Operation Manager

AL/wtc

Encl. Get All Safe Leaflet
General Requirements For Construction Work In The Vicinity Of Gas Main

Agreement No. CE32/2004 (GE)
 Upgrading/Improvement of Roadside Slope/Retaining Walls
 on Hong Kong Island (2005 to 2008 Programme)
 Investigation, Design and Construction

	Feature No.	Easting	Northing	1:1000 Ref.	Location
	11SW-A/C 55	833240	815849	11SW-8C	Conduit Road
	11SW-A/C 123	831433	815701	11SW-6D	Pokfield Road
	11SW-A/C 301	831128	815076	11SW-11B	Mount Davis Road
	11SW-A/CR 711	832030	816134	11SW-7C	Hill Road
	11SW-A/R 1	833400	816316	11SW-8A	Lower Lascar Row
	11SW-A/R 35	833208	816150	11SW-8C	Pound Lane
	11SW-A/R 432	833049	816243	11SW-18A	High Street
	11SW-A/R 967	833558	815657	11SW-8C	Robinson Road
	11SW-B/R 93	834192	815640	11SW-8D	Duddell Street
	11SW-B/R 550	835363	815116	11SW-14B	Kennedy Road
	11SW-D/C 59	834184	812536	11SW-23D	Aberdeen Reservoir Road
	11SW-D/C 858	836596	812144	11SW-25C	Shouson Hill Road
	11SW-D/C1208	834636	814624	11SW-14C	Lloyd Path
	15NE-A/C 44	837665	810917	15NE-1C	Repulse Bay Road
	15NE-A/C 146	839918	809321	15NE-12B	Stanley Village Road
	15NE-A/C 151	839933	809146	15NE-12B	Stanley Village Road
	15NE-A/C 339	840046	809498	15NE-12B	Stanley Gap Road
	15NE-A/CR 252	838718	810647	15NE-6B	Repulse Bay Road
X	15NE-B/C 71	843491	811319	15NE-4D	Big Wave Bay Road
	15NE-C/C 9	840350	808244	15NE-17B	Wong Ma Kok Road
	15NE-C/C 220	839853	808990	15NE-12D	Carmel Road

X : No existing gas plant is affected.



Towngas

The Hong Kong and China Gas Company Limited

[此乃中文譯本，內容以英文本為準]

來函編號： _____

本函編號： _____

_____先生/小姐：

查詢煤氣管道

茲收到貴公司於____年__月__日發出的函件，索取有關煤氣管道位置的圖則。現隨函附上一份現有及擬建管道位置的圖則，此等圖則只作工程參考之用，管道的實際位置和深度可能因為道路的發展、系統的改變及地下設施的阻礙而與圖則所示有些微差距。另外，部分現有的管道是由其他的註冊氣體工程承辦商鋪設或是建於很久之前，以致本公司沒有相關的記錄。貴公司在施工期間如發現來歷不明的管道，請即與本公司聯絡。

本公司建議貴公司切勿在煤氣管道附近施工，以免引起嚴重意外，在施工期間務必要加倍小心。貴公司須以人手開挖探孔來確定煤氣管道的位置及深度，不能使用重型機械如機動探孔機或挖土機。如貴公司損毀本公司的煤氣管道，一切因事故所引致的支出及費用，將全部由貴公司承擔。

請注意不要移動煤氣管道以及相關的配件，也不可以用任何混凝土結構臨時或永久套入部分或全部煤氣管道。為方便本公司日後進行維修保養工作，貴公司的設施與氣體鋼管之間須保留600毫米的間距，與其他氣體管道之間也要保留300毫米的間距。

如貴公司的工程包括新建沙井或於現有沙井內進行，本公司建議將沙井內所有導管接口密封，避免積聚危險氣體而可能引致爆炸。

貴公司如需要改動煤氣管道的路線：如屬配氣管道，請於施工前至少兩個月以書面通知本公司；如屬輸氣管道，則須於施工前至少6個月發出書面通知，以便作出安排，一切相關費用須由貴公司支付。

安全事項：

1. 如有損毀煤氣管道或懷疑有氣體洩漏，請即致電緊急服務熱線28806999。此外，也須盡快熄滅所有火種。
2. 在煤氣管道附近工作時嚴禁吸煙。
3. 如有氣體洩漏，請立刻停止工作，並把所有工作人員及公眾人士撤離事發地點。
4. 在外露的煤氣管道3米範圍內，不可進行任何使用明火的工序。但於施工前經認可途徑申請並獲有關管理單位批准（如獲發工作准許證等）的工序，則作別論。

如需要本公司就管道位置安排工地視察，請致電29631811與陳遠樂先生聯絡。另外，貴公司須在施工前至少一星期通知本公司有關工程的開展日期。如須查詢有關擬建管道或煤氣供應的事宜，請致電29631830與劉潤良先生聯絡。

網絡監控經理

梁志剛謹啟
(日期)



Towngas

The Hong Kong and China Gas Company Limited

24506
6-1-2

EC Drawing

19 October 2005

Your Ref: 24506/GEO/0002ET-LETTER
Our Ref: UNE2005/10527/I

W2410

Ove Arup & Partners
Level 5, Festival Walk,
80 Tat Chee Avenue,
Kowloon Tong,
Kowloon.

Attn. : Ms Elvina Tam

In view of safety, HKCG provides FREE service to assist the road opening parties to locate the approximate gas pipe alignment on site, Please call **29631811** before work starts.

Dear Madam

Re: Agreement No. CE32/2004 (GE), Upgrading / Improvement of Roadside Slope / Retaining Walls on Hong Kong Island (2005 to 2008 Programme), Investigation, Design and Construction, Request for Existing Utility Information

We received your letter of 05 October 2005 requesting drawings on the location of Towngas pipelines. We are attaching the drawings for the location of existing/proposed pipelines that you requested. These drawings are only approximate. The pipes may be located in different positions and depths due to continual road development, system alterations and underground obstructions. Therefore, the exact location may be altered from point to point. There is the possibility that some gas pipes particularly those laid long time ago or laid by other Registered Gas Contractors may not appear in our records. In the case of some unknown pipes being exposed during your construction work, please contact us immediately.

We suggest that you do not work too close to the pipes as any damage to them could create a hazardous accident. You should be very careful when excavating the area. You should locate the exact position and depth of the pipes by making a series of hand-dug trial holes. Heavy machinery such as drills or mechanical excavators cannot be used to do this. If your company damages our pipelines, you will be responsible for all resultant costs.

We would also like to remind you not to disturb any part of Towngas pipeline or their associated properties and not to temporarily or permanently encase part or all of our gas pipes in any form of concrete structures. Please provide steel gas pipes a clearance of 600mm and other gas pipes a clearance of 300mm. This space is necessary for future maintenance.

1

If your work involves construction of new manholes or performing operation in existing manholes, we recommend sealing off all the duct openings in new/existing manholes, to avoid accumulation of hazardous gas in manholes, which might create a dangerous explosive environment.

If you want to divert gas pipes, we must have at least two months and six months notice respectively for distribution and transmission networks before commencing our planning works. Your company will be responsible for the full cost of any diversion. A written agreement will be required before we begin any diversion.

SAFETY:

1. If a gas pipe is damaged or a leak is suspected, phone the Emergency Services Hotline, 28806999, immediately. Also, keep all ignition sources away from the site.
2. Cigarette smoking is prohibited when working near the pipelines.
3. In case of a leak, stop work, evacuate all employees and the public from the area.
4. Construction activities require naked fire must not be applied within 3 meters proximity of exposed gas pipes without prior approval under proper management procedures, such as permit to work, etc.

Please contact Mr Chan Yuen Lok on 2963 1811 to arrange for a joint site inspection regarding the pipe location. Further, you must notify us at least one week before beginning work on site. For enquiry of proposed pipeline, if any, or availability of gas supply, please contact Mr Y L Lau on 2963 1830.

Yours faithfully



ALP Albert C K Leung
System Operation Manager

AL/wtc

Encl. Get All Safe Leaflet
General Requirements For Construction Work In The Vicinity Of Gas Main

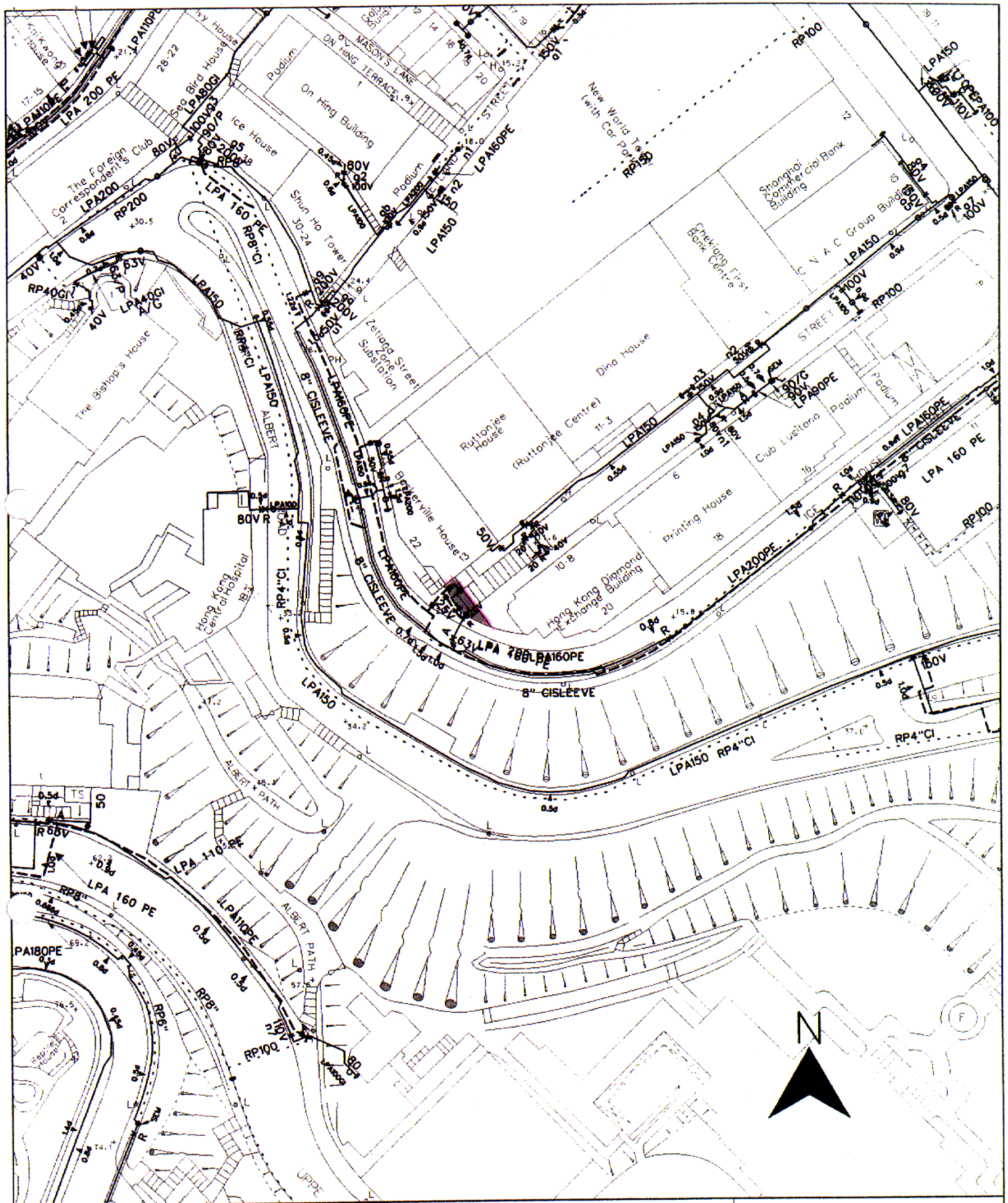

煤氣 Towngas
 香港中華煤氣有限公司
 The Hong Kong and China Gas Company Limited

網絡部
 時間: 12:54:8
 比例: 1:1000

圖例:

LPA	現有低壓A管線 (2千呎以下)	——	鋼蓋管
LPB	現有低壓B管線 (2-7.5千呎)	○	汽缸埋管
MP	現有中壓管線 (7.5-240千呎)	○	無蓋管內汽缸埋管/收散點
LPA	現有一次高壓A管線 (340-400千呎)	○	閘門
LPB	現有一次高壓B管線 (400-700千呎)	○	球閘井
MP	現有中壓管線 (700千呎以上)	○	雙層保護裝置
PL	設有可探測管破裂的聚乙烯管線	○	泥濘管溝
PL+	設有可探測管破裂的聚乙烯管線	○	大約埋深 (米)
RP	埋地管線	++++	管溝過路管

圖則顯示的管道位置只作參考之用。其實際位置和深度仍須以人手開挖探孔確定。在煤氣管道設施附近施工期間，必須要加倍小心。
 檢查日期: : Oct 14 2005

座標: xy (834199,815643) UNE2005/10471_9/1

圖則上的地圖資料乃得到 (C)香港地政總署提供 准許翻印 在未經得到香港中華煤氣有限公司批准前，不可翻印此圖則的全部或部分內容

11SW-B/R73



Our Ref. MIS/NWT/PE/05/7295
Your Ref 24506/GEO/0001ET-LETTER

Date 12 October 2005

Miss Elvina Tam
Ove Arup & Partners Hong Kong Ltd
Level 5, Festival Walk
80 Tat Chee Avenue
Kowloon Tong, Kowloon
Hong Kong

Dear Miss Tam

Request for Utility Services Information
Agreement No. CE32/2004 (GE)

Thank you for your letter of 04 October 2005 regarding the captioned works.

Upon your request, we hereby inform that we have no current plant or services and proposed installation located in the area where you propose to work as of the date of this letter.

Take notice that the information contained herein is current and accurate as at the date of this letter. We have the right to change amend or alter the present stated situation at any time and in whatever manner as we see fit and have no responsibility whatsoever to inform you. You or your authorized contractors must exercise best endeavour to satisfy yourself with the latest situation prior to commencement of the captioned works. You or your contractors are advised to contact us for the latest information before the commencement of the captioned works. Please be advised that notwithstanding any representation contained in this letter, you will be held liable for any and all damages or losses that may arise directly or indirectly to our properties and business profits in relation to the captioned works.

Should you require any further information, please feel free to contact Mr K T Ho, Engineer on Tel. No. 21337189.

Yours sincerely

Carol Cheng

S M Cheng
External Plant
Senior Draftsman



Our Ref. MIS/NWT/PE/05/7238
Your Ref 24506/GEO/0002ET-LETTER

Date 12 October 2005

Miss Elvina Tam
Ove Arup & Partners Hong Kong Ltd
Level 5, Festival Walk
80 Tat Chee Avenue
Kowloon Tong, Kowloon
Hong Kong

Dear Miss Tam

**Request for Utility Services Information
Agreement No. CE32/2004 (GE)**

Thank you for your letter of 05 October 2005 regarding the captioned works.

Upon your request, we hereby inform that we have no current plant or services and proposed installation located in the area where you propose to work as of the date of this letter.

Take notice that the information contained herein is current and accurate as at the date of this letter. We have the right to change amend or alter the present stated situation at any time and in whatever manner as we see fit and have no responsibility whatsoever to inform you. You or your authorized contractors must exercise best endeavour to satisfy yourself with the latest situation prior to commencement of the captioned works. You or your contractors are advised to contact us for the latest information before the commencement of the captioned works. Please be advised that notwithstanding any representation contained in this letter, you will be held liable for any and all damages or losses that may arise directly or indirectly to our properties and business profits in relation to the captioned works.

Should you require any further information, please feel free to contact Mr K T Ho, Engineer on Tel. No. 21337189.

Yours sincerely

Carol Cheng

S M Cheng
External Plant
Senior Draftsman

Wharf T&T Limited
九倉電訊有限公司

9/F, Wharf T&T Tower
No. 1, Canton Road
Kowloon
Telephone: (852) 2112 7757
Facsimile: (852) 2112 7757
Website: www.wharf.com



20-Oct-05

Your Ref.: 24506/GEO/0002eT-LETTER
Our Ref.: NTT-HK05-1272-1/mkl

Our Fax. No.: 2112 7757

Ove Arup & Partners Hong Kong Ltd
Level 5 Festival Walk,
80 Tat Chee Avenue,
Kowloon Tong,
Kowloon

Attn.: Ms. Elvina Tam

Dear Ms. Tam,

Agreement No.CE32/2004(GE)
Upgrading / Improvement of Roadside Slope / Retaining Walls on Hong Kong Island
(2005 to 2008 Programme) Investigation, Design and Construction
Request for Existing Utility Information

Thank you for your letter of 05-Oct-05.

Please be advised that we do not have any existing and proposed plant in the vicinity of your works area at the present time.

Should you require any further information, please feel free to contact our Mr. M K Ling at 2112 3533.

Yours faithfully,
For and on behalf of
Wharf T & T Limited

Y W Leung
Project Manager

wen0518-e-civilletternttHK05-1272-1.doc

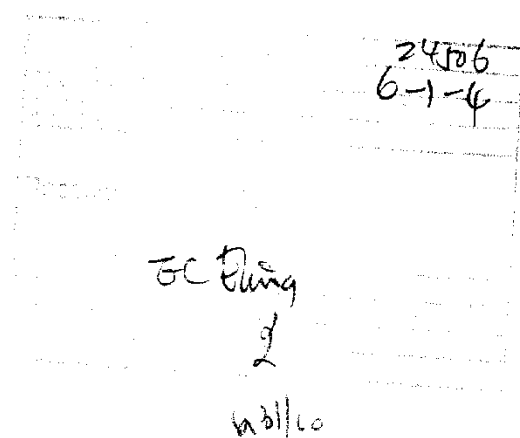

Wharf T&T Limited
九倉電訊有限公司

Infrastructure Planning & Projects
40/F, Cable TV Tower
9 Hoi Shing Road, Tsuen Wan, NT
Telephone No. 2112 3525
Fax No. 2112 7757
Website: www.wharftt.com
01-Mar-06



Your Ref.: 24506/GEO/0005ET-LETTER
Our Ref.: NTT-HK06-0197-1/mkl

Our Fax. No.: 2112 7757

Ove Arup & Partners Hong Kong Ltd.
Level 5, Festival Walk
80 Tat Chee Avenue
Kowloon Tong,
Kowloon

Attn.: Mr. Calvin Cheung

Dear Mr. Cheung,

24506
6-1-4
DATE
RECEIVED
23 JAN 2006
cc Calvin Cheung
1
2
Copy

Agreement No. CE32/2004(GE)

Upgrading/ Improvement of Roadside Slope/ Retaining Walls on Hong Kong Island
(2005 to 2008 Programme)

Investigation, Design and Construction
Request for Existing Utility Information

Thank you for your letter of 23-Jan-06.

Please be advised that we do not have any existing and proposed plant in the vicinity of your works area at the present time.

Should you require any further information, please feel free to contact our Mr. M K Ling at 2112 3533.

Yours faithfully,
For and on behalf of
Wharf T & T Limited

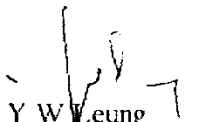
Y W Leung
Project Manager

wen0518--ccivil:letter\ntt\HK06-0197_1.doc

4

Date : 17 February 2006

Our Ref : RW/HK/06/051(H)
 Your Ref : 24506/GEO/0004ET-LETTER

Ove Arup & Partners Hong Kong Ltd.
 Level 5, Festival Walk,
 80 Tat Chee Avenue,
 Kowloon Tong,
 Kowloon, Hong Kong.

Attn: Mr. Calvin Cheung

Dear Mr. Cheung

RE: Agreement No. CE 32/2004 (GE)
Upgrading/Improvement of Roadside Slope/Retaining Walls on
Hong Kong Island (2005 to 2008 Programme)

AIRUP		Job No.	24506
Reply Ref.:		File No.	6-1-5
Action Required:		By:	
Received - 1 MAR 2006			
Init.	Calvin Cheung		
Action			
Info.			
Copy	2	2	

6/3

Thank you for your letter dated 23 January 2006 regarding the above captioned subject.

We enclose a copy of your plan Dwg.no. RW/HK/06/051(H)1/24-24/24 showing the approximate location of our existing / proposed plant in the vicinity of your construction site.

Please note that the depth of the plant may vary for various reasons. Therefore, you may expect to find the plant located at any depth below surface level on site. We advise you to take utmost caution when excavating in the area and the plant should be located by hand excavation prior to the commencement of work. In the event that any damage occurs to the plants as a result of your operations, you will be held liable and shall indemnify us for all such as losses, costs and damages arising from your actions.

For further information, please contact our Mr. Sammy Cheung on telephone no. 2128 3742 or fax 1 9397.

Yours sincerely,
 Hutchison Global Communications Limited

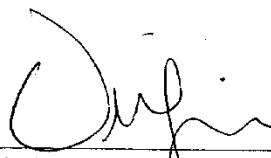
 Virginia Leung
 Engineer - Infrastructure Development

VL/T/sc

c.c. Mr. K C Wun - (TE)

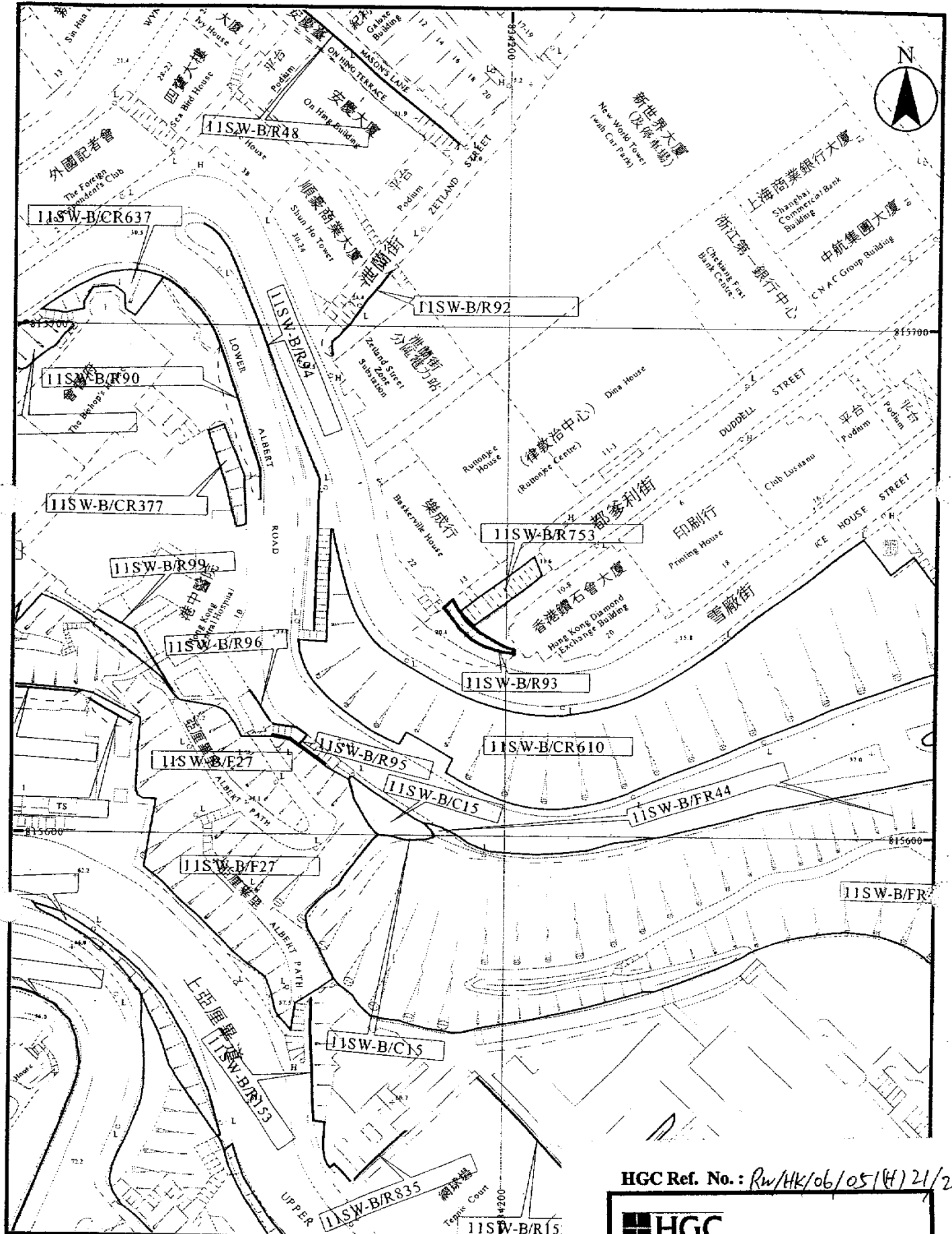

HGC Ref. No. : Rm/HK/06/05(H) 21/24



No existing and proposed plant in the vicinity of your work site

Job Title
AGREEMENT NO. CE 32/2004 (GE)
 Upgrading/Improvement of Roadside Slopes/Retaining Walls on Hong Kong Island (2005 to 2008 Programme)
 - Investigation, Design and Construction

Figure Title
Feature Location Plan
 Feature No. 11SW-B/ R93*
 Duddell Street
 11SW 8D

Ove Arup & Partners
Level 5 Festival Walk
80 Tat Chee Avenue
Kowloon Tong
Kowloon

Job No. 24506	File No. 6-1-6
20 OCT 05	
GC Wong	
2	

Your Reference : 24506/GEO/0001ET-LETTER

Our Reference : HKT-20051018-0028-R-HKT

Telephone : 2883 5617

Fax : 2527 3463

Date : 18-Oct-2005

Dear Ms Elvina Tam

Agreement No. CE32/2004(GE)

**Upgrading / Improvement of Roadside Slope / Retaining Walls
on Hong Kong Islands (2005 to 2008 Programme)**

**Investigation, Design and Construction - Feature No. (11SW-A/C55, 11SW-A/C301, 11SW-A/R35,
11SW-A/R432, 11SW-A/R967, 11SW-B/R93, 11SW-B/R550, 11SW-D/C59, 11SW-D/C858, 15NE-A/C44,
15NE-A/C146, 15NE-A/C151, 15NE-A/C339, 15NE-A/CR252, 15NE-B/C71, 15NE-C/C220)**

Thank you for your letter and enclosures of 04-Oct-2005

We enclose a set of plan(s) indicating the approximate position of our existing or proposed underground plant in the area of your proposed excavations. The information contained in the plan(s) can only be used in conjunction with the proposed work and must not be disclosed to other third parties.

Please note that the depth of the plant may vary for various reasons. Therefore, you may expect to find the plant located at any depth below surface level on site.

We advise you to take utmost caution when excavating in the area and to locate the plant by hand excavation prior to the commencement of work. If damage occurs to telephone cable, it will interrupt telephone services, mobile telephone services, 999 or emergency help line services, international telephone services, medical services and the banking services in many areas which affect many peoples and is also a threat to public safety. In the event that we suffer any losses, costs or damages as a result of your operations, you will be held liable and shall indemnify us for all such losses, costs and damages arising from your actions.

In order to draw your workers attention for the existence of our underground plant nearby and excavate carefully, our Plant Protection Officer would stick and display our standard design excavation carefully warning posters of A4 size on your construction site.

Please convey all the information to your workers, including your sub-contractors. You are advised to inform us before work commencement.

For plant protection inquiry, please refer to the below:

Exchange Area	Contact Person	Telephone Number
QNR ADM	Mr Chan Chik Shing	29271899
ABD KTN	Mr Ng Yung Tim	2927 1818
LKT	Mr Shum Kwok Shing	2927 1828
RBV SKO STN	Mr Lai Man Wai	2927 1838

Yours sincerely
WONG KIN WA
For and on behalf of
PCCW-HKT Telephone Limited

Enc. HKT-20051018-0028-R-HKT-01 ~ 16.dgn



Ove Arup & Partners Hong Kong Ltd

Level 5 Festival Walk
80 Tat Chee Avenue
Kowloon Tong
Kowloon

Your Reference : 24506/GEO/0001ET-LETTER

Our Reference : HKT-20051018-0029-R-HKT

Telephone : 2883 5617

Fax : 2527 3463

Date : 18-Oct-2005

Dear Ms Elvina Tam

**Agreement No. CE32/2004(GE)
Upgrading / Improvement of Roadside Slope /Retaining Walls
on Hong Kong Islands (2005 to 2008 Programme)
Investigation, Design and Construction
Feature No. (11SW-A/C123, 11SW-A/R711, 11SW-A/R1, 11SW-D/C1208, 15NE-C/C9)**

Thank you for your letter and enclosures of 04-Oct-2005

We would like to inform you that we do not have any underground plant in the vicinity of your proposed works at the present time.

Yours sincerely
WONG KIN WA
For and on behalf of
PCCW_HKT Telephone Limited



File No	24506
File No	6-1-6
Date	
Reply Ref.	
Action Required	
Received	18 OCT 2005
File No	
Action	
Info	Your Reference : 24506/GEO/0002ET-LETTER
Copy	

Ove Arup & Partners (HK) Ltd.

Level 5 Festival Walk
80 Tat Chee Avenue
Kowloon Tong

Your Reference : 24506/GEO/0002ET-LETTER

Our Reference : HKT-20051014-0088-R-HKT

Telephone : 28835617

Fax : 25273463

Date : 14-Oct-2005

Dear Ms Elvina Tam

Agreement No. CE32/2004 (GE)

Upgrading . Improvement to Roadside Slope / Retaining Walls on Hong Kong Island (2005 to 2008 Programme) Investigation , Design and Construction - Slope No. 11SE-A/F221, 11SW-A/C678, D/C524, 15NE-A/C187

Thank you for your letter and enclosures of 5-Oct-2005

We enclose a set of plan(s) indicating the approximate position of our existing or proposed underground plant in the area of your proposed excavations. The information contained in the plan(s) can only be used in conjunction with the proposed work and must not be disclosed to other third parties.

Please note that the depth of the plant may vary for various reasons. Therefore, you may expect to find the plant located at any depth below surface level on site.

We advise you to take utmost caution when excavating in the area and to locate the plant by hand excavation prior to the commencement of work. If damage occurs to telephone cable, it will interrupt telephone services, mobile telephone services, 999 or emergency help line services, international telephone services, medical services and the banking services in many areas which affect many peoples and is also a threat to public safety. In the event that we suffer any losses, costs or damages as a result of your operations, you will be held liable and shall indemnify us for all such losses, costs and damages arising from your actions.

In order to draw your workers attention for the existence of our underground plant nearby and excavate carefully, our Plant Protection Officer would stick and display our standard design excavation carefully warning posters of A4 size on your construction site.

Please convey all the information to your workers, including your sub-contractors. You are advised to inform us before work commencement.

For plant protection inquiry, please contact refer to the below :-

Exchange Area	Contact Person	Telephone Number
KGR STN	Mr Lai Man Wai	2927 1838
KTN	Mr Ng Yung Tim	2927 1818
PKK	Mr Chan Chik Shing	2927 1899

Yours sincerely
Wong Kin Wa
For and on behalf of
PCCW-HKT Telephone Limited

Enc.

HKT-20051014-0088-R-HKT-01-04.dgn

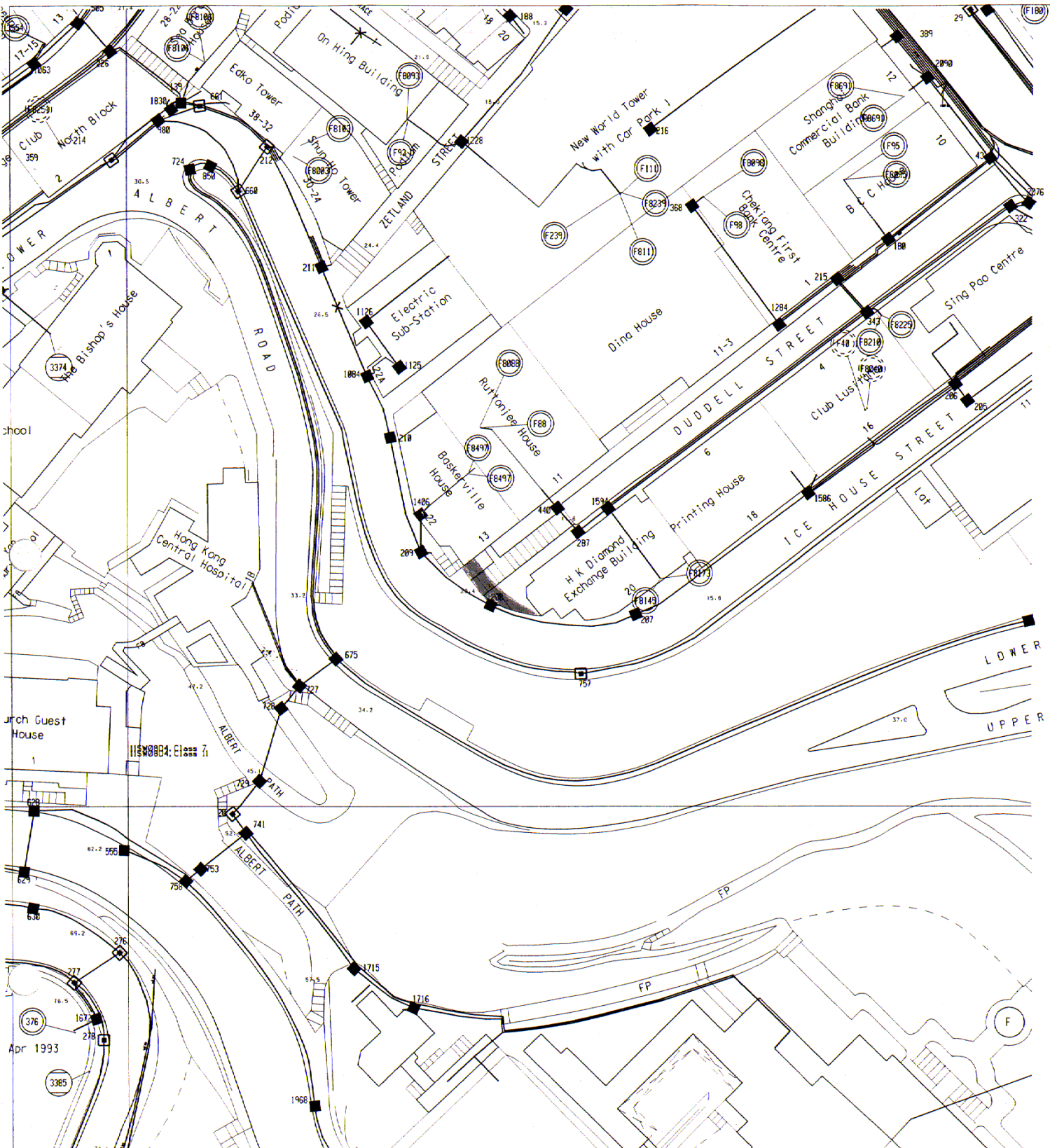

PCCW
電訊盈科

OUTSIDE PLANT PLANNING & DESIGN
EXCH. AREA : ADM
SURVEY MAP No. 11sw08d

UU REF. No. 24506/GEO/0001ET-LETTER
PREP. CYL SCALE 1 : 1000
CKD. CYL DATE 18/10/2005
DWG. No. HKT-20051018-0028-R-HKT-06

- NOTES :
- EXCEPT FOR YOUR PROSPECTIVE CONTRACTORS/EMPLOYEES. THIS DRAWING MUST NOT BE RELEASED TO THIRD PARTY WITHOUT HK TELEPHONE'S WRITTEN APPROVAL.
 - THIS INFORMATION IS ACCURATE AT THE DATE BELOW, BUT FURTHER ALTERATIONS/AUGMENTATION MAY TAKE PLACE IN THE FUTURE.
 - THE POSITION OF PLANT INDICATED ON THIS DRAWING IS APPROXIMATELY ONLY. ACTUAL DEPTH AND POSITION OF PLANT MUST BE ESTABLISHED BEFORE COMMENCEMENT OF WORK BECAUSE VARIATIONS OF DEPTH AND LINE MAY OCCUR. EXTREME CARE MUST BE EXERCISED WHEN EXCAVATIONS ARE MADE IN PROXIMITY TO SUCH PLANT.
 - REACH NETWORKS HONG KONG LIMITED'S PLANT INCLUDED.

KEY OF PLANT	EXISTING	PROPOSED
MANHOLE	■	◻
JOINT BOX	■	◻
DUCT	—	---
CABLE	—	---
POLE	○	○
CABINET	⊠	⊠
BURIED COUPLING	×	×

FEATURE NO. 11SW-B/R93

Map data reproduced with permission of the director of lands. (C) Hong Kong Government

11SW-B/R93



17-Feb-2006

Your Ref. : 24506/GEO/0004ET-LETTER
Our Ref. : HMP 5521-1/KFY

GEO FILE COPY
24 FEB 2006

Our Fax No. 21127879

Ove Arup & Partners Hong Kong Limited
Level 5, Festival Walk
80 Tat Chee Avenue
Kowloon Tong
Kowloon
Hong Kong

Attn : Mr. Calvin Cheung

Dear Sir,

ARUP		Job No.	24506
Reply Ref.:		File No.	6-1-1
Action Required:		By:	Date
Received 23 FEB 2006			
Init.	EC	Calvin Cheung	
Action			
Info.			
Copy			

Agreement No. CE32/2004 (GE)
Upgrading/ Improvement of Roadside Slope/ Retaining Walls
on Hong Kong Island (2005 to 2008 Programme)
Investigation, Design and Construction
Request for Existing Utility Information

Thank you for your letter dated 23 January 2006.

We return a copy of our drawing no. HMP 5521-1_KFY(6 shts) on which we have marked the approximate location of our existing plant for your information. For those of other plans not being returned, we do not have any existing plant in the vicinity of your proposed work.

Please advise your contractor to take extreme care to avoid damage to our plants as we will hold him liable to any costs incurred resulting from damage.

Should you require any further information, please feel free to contact our MR K F Yan on 2112 3587.

Yours faithfully,
For and on behalf of
Hong Kong Cable Television Limited

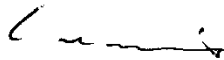
Cennis Leung
Manager - Civil Planning
Survey, Design & Programme Offices

c.c. Mr. K. K. Chan - For plant watching please



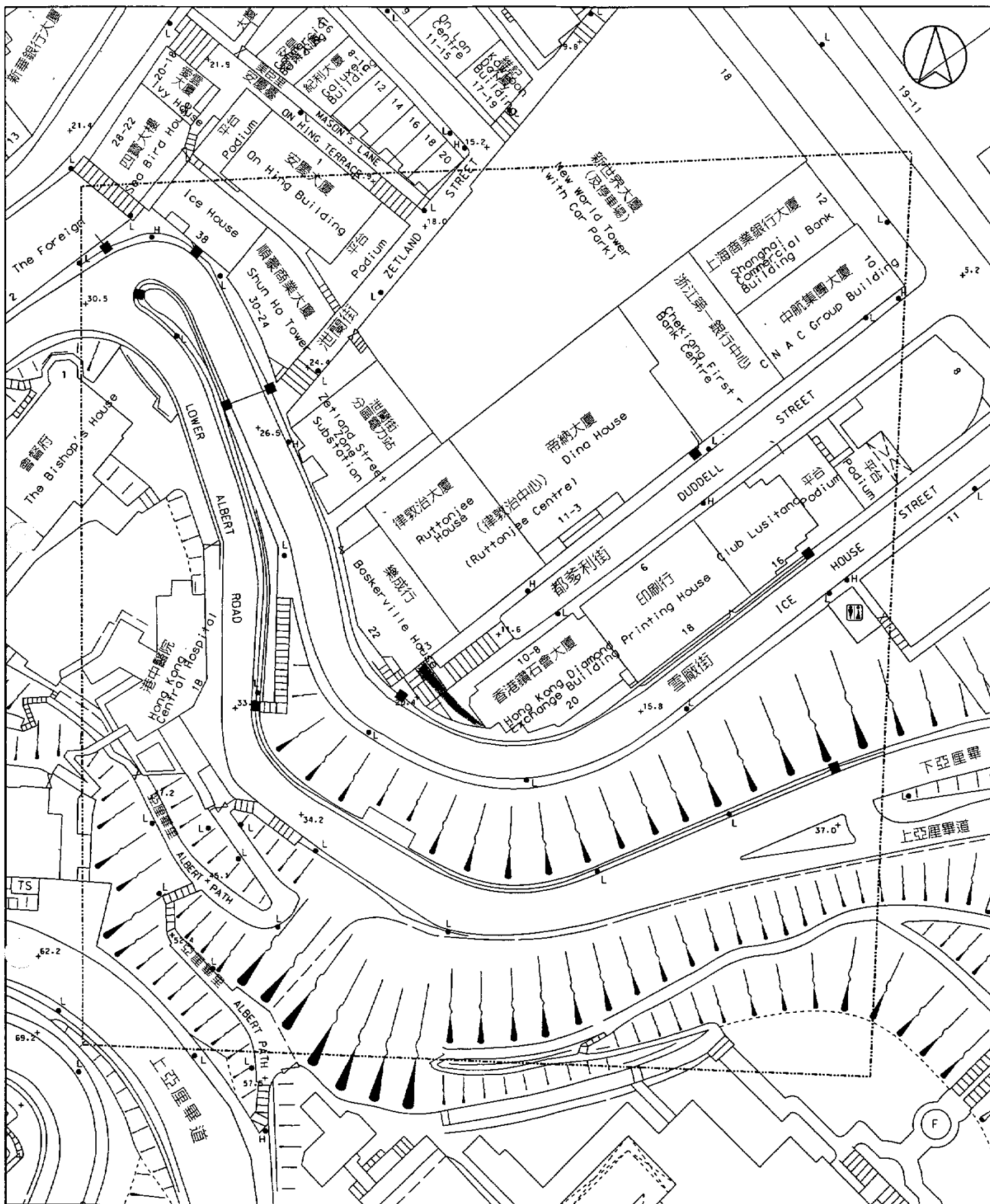

LEGEND:

	PROPOSED JOINTING CHAMBER
	AS-BUILT JOINTING CHAMBER
	PROPOSED DUCT ROUTE
	AS-BUILT DUCT ROUTE
	CONCERNED WORK AREA BOUNDARY (ONLY PLANTS INSIDE THE BOUNDARY AREA ARE EXTRACTED)

LOCATION: FOR FEATURE NO. 11SW-B/R93	
SURVEY MAP: 11sw08d 11sw13b	
OUR REF: HMP 5521-1/KFY	SCALE: 1:1000
YOUR REF: 24506/GEO/0004ET-LETTER	ISSUED BY: K. F. YAN
FILE (DWG NO): HMP 5521-1_KFY	DATE: 17-Feb-2006
SMO MAP DATA REPRODUCED WITH PERMISSION OF THE DIRECTOR OF LANDS (C) HONG KONG SPECIAL ADMINISTRATIVE REGION GOVERNMENT.	

1. THE POSITION OF PLANT INDICATED ON THIS DRAWING IS APPROXIMATE ONLY.
2. THE DEPTH OF OUR PLANT MAY VARY DUE TO UNDERGROUND OBSTRUCTIONS.
3. YOUR CONTRACTOR IS ADVISED TO DIG INSPECTION PITS TO LOCATE THE PLANT BEFORE COMMENCEMENT OF WORKS. EXTREME CARE MUST BE EXERCISED TO AVOID DAMAGE TO OUR PLANT.

**HIGHWAYS DEPARTMENT
LIGHTING DIVISION**

10TH FLOOR, TOWER 1, CHEUNG SHA WAN PLAZA
833 CHEUNG SHA WAN ROAD, LAI CHI KOK, KOWLOON, HONG KONG
Web site : <http://www.hyd.gov.hk>

路政署
路燈部
香港九龍荔枝角長沙灣道 833 號
長沙灣廣場第一期十樓
網址: <http://www.hyd.gov.hk>

本署檔案 Our Ref. : (44DY) in HyD LTG/15-4/13/14
來函編號 Your Ref. : 24506/GEO/04-20/AH/EC/1046THC
電話 Tel. : 2370 4816
圖文傳真 Fax : 2310 8489

ARUP
Level 5 Festival Walk
80 Tat Chee Avenue
Kowloon Tong
Kowloon, Hong Kong.
(Attn: Mr. Eddie Chan)

5 February 2013

Dear Sirs,

**Agreement No. CE 32/2004 (GE)
Upgrading / Improvement of Roadside Slopes / Retaining Walls on
Hong Kong Island (2005 to 2008 Programme) – Investigation, Design and
Construction Circulation of Project Plans for Feature No. 11SW-B/R93,
Duddell Street, Hong Kong**

I refer to your above reference letter dated 29 January 2013 regarding the subject matters and have no objection in principle from lighting design view point.

Please seek comments from Mr. Gary Leung, of our maintenance agent, EMSD, on your proposal in respect of the possible impact on the stability and operation of the gas lamps. Mr. Leung's contact telephone number and e-mail address are 2808 3718 and garyhleung@emsd.gov.hk respectively.

Moreover, you should also seek comments from Antiquities and Monuments Office of Leisure and Cultural Services Department.

Yours faithfully,

(Peter W.Y. HO)
for Chief Engineer/Lighting
Highways Department

c.c.

HyD/Works	Mr. Y.K. LAU / Mr. F.K. LAI	Fax.: 3188 3418
EMSD	Mr. Gary LEUNG	Fax.: 2577 1824
LCSD/AMO	Miss Pauline P.T. POON	Fax.: 2721 6216

Internal: E/SL3,
AEI/SL3





Photo 1 - A wet sponge should be placed on the slope surface to absorb most of the fine dust generated during drilling works



Photo 2 - A plywood should be placed and mounted above the sponge to fix the sponge in place

<p>Job Title</p> <p>CONTRACT NO. HY/2008/18</p> <p>Upgrading/Improvement of Roadside Slopes/Retaining Walls on Hong Kong Island (2005 to 2008 Programme) - Second Contract</p>	<p>Figure Title</p> <p>Photo 1 & 2</p> <p>Environmental Protection Measure on Dust Control</p>	<p>ARUP Ove Arup & Partners Hong Kong Limited</p> <p>Scale</p> <p>Drn. THC Date 03/2012 Chd. EC Passed AH</p> <p>Job No. 24506 Photo 1 & 2</p>
---	--	---



Photo 3 - First layer of tarpaulin should be placed above the sponge, the plywood and covering the opening of the drillhole



Photo 4 - Second layer of tarpaulin should be covering everything including the front portion of the drilling rig

<p>Job Title</p> <p>CONTRACT NO. HY/2008/18</p> <p>Upgrading/Improvement of Roadside Slopes/Retaining Walls on Hong Kong Island (2005 to 2008 Programme) - Second Contract</p>	<p>Figure Title</p> <p>Photo 3 & 4</p> <p>Environmental Protection Measure on Dust Control</p>	<p>ARUP Ove Arup & Partners Hong Kong Limited</p> <p>Scale</p> <p>Drn. THC Date 03/2012 Chd. EC Passed AH</p> <p>Job No. 24506</p> <p>Photo 3 & 4</p>
---	--	--

Appendix I

Job title Contract No. HY/2008/18

Job number: 24506

Location Feature No. 11SW-B/R93, Sub-division 1 at Duddell Street



Subject Parapet wall at north-western side (Plate 1) **Date photograph taken** 04-Jan-11

Description View showing the parapet wall at the north-western side of the feature



Subject Parapet wall at north-western side (Plate 2) **Date photograph taken** 04-Jan-11

Description View showing the reinstated portal of parapet wall at the north-western side of the feature

Job title Contract No. HY/2008/18

Job number: 24506

Location Feature No. 11SW-B/R93, Sub-division 1 at Duddell Street



Subject Parapet wall at north-western side (Plate 3) **Date photograph taken** 04-Jan-11

Description View showing the reinstated portal of parapet wall at the north-western side of the feature



Subject Parapet wall at north-western side (Plate 4) **Date photograph taken** 04-Jan-11

Description Part of the corner at the box newel supporting the gas lamp is broken

Job title Contract No. HY/2008/18

Job number: 24506

Location Feature No. 11SW-B/R93, Sub-division 1 at Duddell Street



Subject	Parapet wall at north-western side (Plate 5)	Date photograph taken	04-Jan-11
----------------	--	------------------------------	-----------

Description	Part of the corner at the box newel supporting the gas lamp is broken
--------------------	---



Subject	Parapet wall at south-western side (Plate 6)	Date photograph taken	04-Jan-11
----------------	--	------------------------------	-----------

Description	A gap between the box newel and the south-western side of the parapet wall is observed
--------------------	--

Job title Contract No. HY/2008/18

Job number: 24506

Location Feature No. 11SW-B/R93, Sub-division 1 at Duddell Street



Subject Parapet wall at south-western side (Plate 7) **Date photograph taken** 04-Jan-11

Description A gap between the box newel and the south-western side of the parapet wall is observed



Subject Parapet wall at south-western side (Plate 8) **Date photograph taken** 04-Jan-11

Description A gap between the box newel and the south-western side of the parapet wall is observed

Job title Contract No. HY/2008/18

Job number: 24506

Location Feature No. 11SW-B/R93, Sub-division 1 at Duddell Street



Subject Parapet wall at south-western side (Plate 9) **Date photograph taken** 04-Jan-11

Description One of the box newels at the south-western of the feature is damaged by the tree roots



Subject Parapet wall at south-western side (Plate 10) **Date photograph taken** 04-Jan-11

Description A gap between the south-western side of the parapet wall and the base is observed

Job title Contract No. HY/2008/18

Job number: 24506

Location Feature No. 11SW-B/R93, Sub-division 1 at Duddell Street



Subject Parapet wall at south-western side (Plate 11) **Date photograph taken** 04-Jan-11

Description The parapet wall is connected to an existing concrete wall with mosaic tiles



Subject Parapet wall at south-western side (Plate 12) **Date photograph taken** 04-Jan-11

Description Apparent cracks formed by the tree is observed at the south-western parapet wall

Job title Contract No. HY/2008/18

Job number: 24506

Location Feature No. 11SW-B/R93, Sub-division 1 at Duddell Street



Subject	Granite Stone Staircase (Plate 13)	Date photograph taken	04-Jan-11
----------------	------------------------------------	------------------------------	-----------

Description	General view of the granite stone staircase
--------------------	---

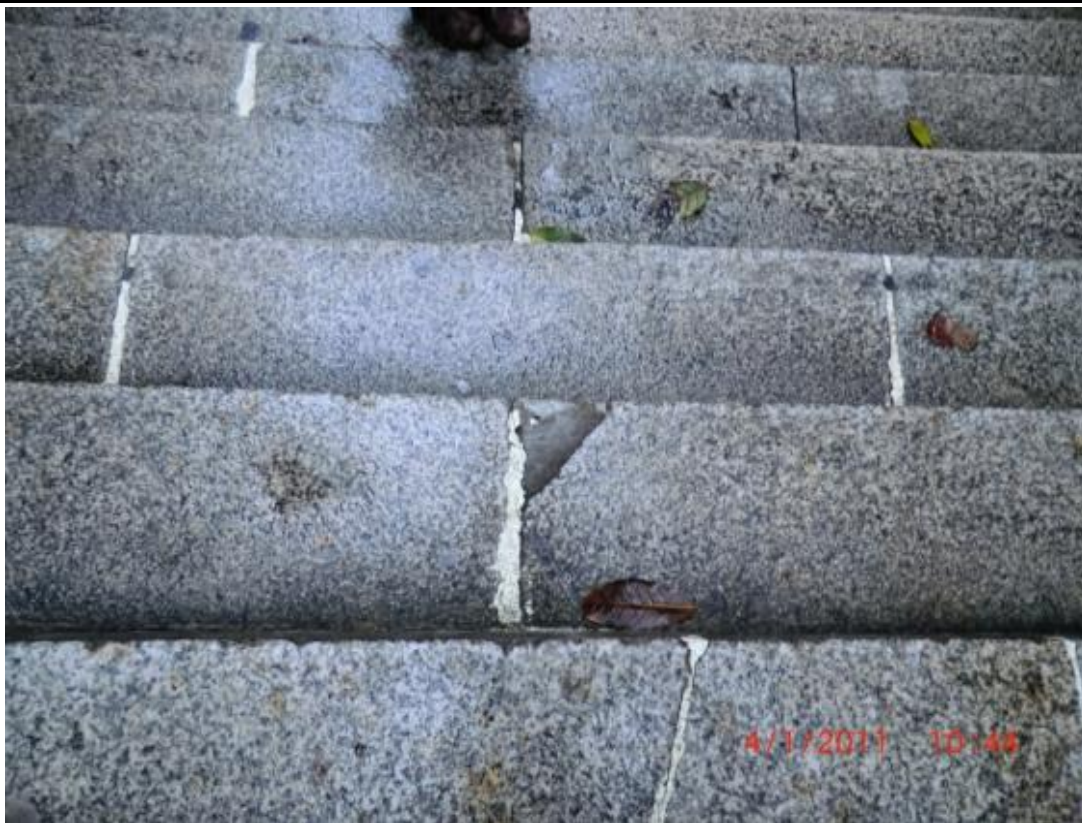

Subject	Granite Stone Staircase (Plate 14)	Date photograph taken	04-Jan-11
----------------	------------------------------------	------------------------------	-----------

Description	View showing the re-instatement works carried out for the granite stone staircase
--------------------	---

Job title Contract No. HY/2008/18

Job number: 24506

Location Feature No. 11SW-B/R93, Sub-division 1 at Duddell Street



Subject Granite Stone Staircase (Plate 15) **Date photograph taken** 04-Jan-11

Description General view showing the declared monuments



Subject Granite Stone Staircase (Plate 16) **Date photograph taken** 04-Jan-11

Description General view showing the granite stone staircase and handrailings

Job title Contract No. HY/2008/18

Job number: 24506

Location Feature No. 11SW-B/R93, Sub-division 1 at Duddell Street



Subject	Granite Stone Staircase (Plate 17)	Date photograph taken	18-Oct-10
----------------	------------------------------------	------------------------------	-----------

Description	General view showing the pattern on the landings - two crosses
--------------------	--



Subject	Granite Stone Handrailing (Plate 18)	Date photograph taken	04-Jan-11
----------------	--------------------------------------	------------------------------	-----------

Description	View showing the general condition of balusters at the southern side of the feature
--------------------	---

Job title Contract No. HY/2008/18

Job number: 24506

Location Feature No. 11SW-B/R93, Sub-division 1 at Duddell Street



Subject Granite Stone Handrailing (Plate 19) **Date photograph taken** 04-Jan-11

Description View showing the general condition of balusters at the northern side of the feature



Subject Granite Stone Handrailing (Plate 20) **Date photograph taken** 04-Jan-11

Description View showing the connection between the handrailing and one of the box newels

Job title Contract No. HY/2008/18

Job number: 24506

Location Feature No. 11SW-B/R93, Sub-division 1 at Duddell Street

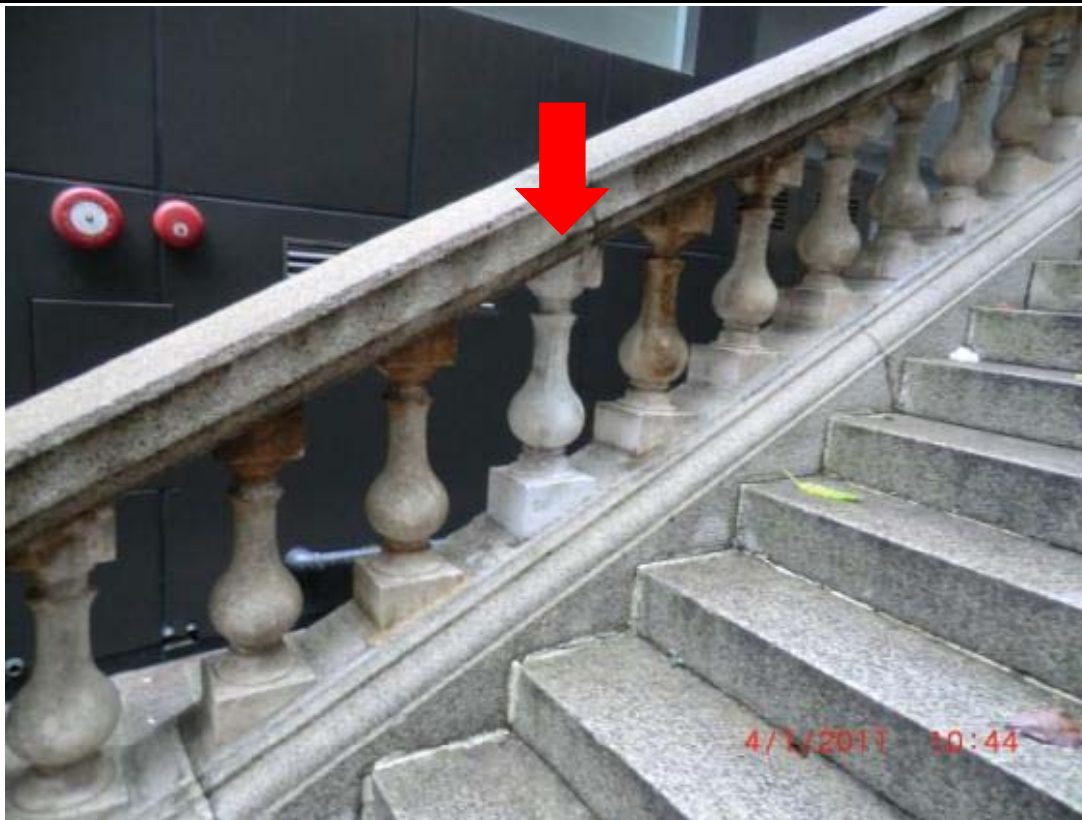

Subject Granite Stone Handrailing (Plate 21) **Date photograph taken** 04-Jan-11

Description View showing the reinstatement works carried out for one of the balusters



Subject Granite Stone Handrailing (Plate 22) **Date photograph taken** 04-Jan-11

Description View showing that the handrailing are connected with cement mortar

Job title Contract No. HY/2008/18

Job number: 24506

Location Feature No. 11SW-B/R93, Sub-division 1 at Duddell Street



Subject Granite Stone Handrailing (Plate 23) **Date photograph taken** 04-Jan-11

Description View showing the connection between the handrailing and one of the box newels



Subject Granite Stone Handrailing (Plate 24) **Date photograph taken** 04-Jan-11

Description Part of the handrailings are damaged prior to the commencement of the Works

Job title Contract No. HY/2008/18

Job number: 24506

Location Feature No. 11SW-B/R93, Sub-division 1 at Duddell Street



Subject Granite Stone Handrailing (Plate 25) **Date photograph taken** 04-Jan-11

Description View showing the reinstated baluster



Subject Granite Stone Handrailing (Plate 26) **Date photograph taken** 04-Jan-11

Description General view of the granite stone handrailing at the toe of the feature

Job title Contract No. HY/2008/18

Job number: 24506

Location Feature No. 11SW-B/R93, Sub-division 1 at Duddell Street



Subject Gas Lamps (Plate 27) **Date photograph taken** 12-Jan-11

Description View showing one of the two gas lamps at Ice House Street



Subject Gas Lamps (Plate28) **Date photograph taken** 12-Jan-11

Description View showing one of the two gas lamps at Ice House Street

Job title Contract No. HY/2008/18

Job number: 24506

Location Feature No. 11SW-B/R93, Sub-division 1 at Duddell Street



Subject Gas Lamps (Plate 29) **Date photograph taken** 12-Jan-11

Description View showing the two gas lamps at Duddell Street



Subject Granite Stone Facing (Plate 30) **Date photograph taken** 04-Jan-11

Description View showing the existing condition of masonry facing of the declared monuments

Job title Contract No. HY/2008/18

Job number: 24506

Location Feature No. 11SW-B/R93, Sub-division 1 at Duddell Street



Subject Storerooms underneath the staircase (Plate 31) **Date photograph taken** 04-Jan-11

Description View showing the entrances of storerooms underneath the staircase



Subject Storeroom with arch ceiling (Plate 32) **Date photograph taken** 12-Jan-11

Description View showing one of the storerooms with a granite arch lintel

Job title Contract No. HY/2008/18

Job number: 24506

Location Feature No. 11SW-B/R93, Sub-division 1 at Duddell Street



Subject Storeroom with arch ceiling (Plate 33) **Date photograph taken** 27-Nov-07

Description The storeroom is painted in yellow and locked by a black wooden door



Subject Storeroom with arch ceiling (Plate 34) **Date photograph taken** 27-Nov-09

Description Some traces of screwholes and coreholes are left on the surface of the wall

Job title Contract No. HY/2008/18

Job number: 24506

Location Feature No. 11SW-B/R93, Sub-division 1 at Duddell Street



Subject Storeroom with arch ceiling (Plate 35) **Date photograph taken** 27-Nov-09

Description Some traces of screwholes and coreholes are left on the surface of the wall



Subject Storeroom with arch ceiling (Plate 36) **Date photograph taken** 27-Nov-09

Description The storeroom is stockpiled with miscellaneous items

Job title Contract No. HY/2008/18

Job number: 24506

Location Feature No. 11SW-B/R93, Sub-division 1 at Duddell Street



Subject Storeroom with arch ceiling (Plate 37) **Date photograph taken** 07-Dec-07

Description The condition of the wooden door and glass window is considered fair



Subject Storeroom with arch ceiling (Plate 38) **Date photograph taken** 07-Dec-07

Description The ceiling plaster is peeling off

Job title Contract No. HY/2008/18

Job number: 24506

Location Feature No. 11SW-B/R93, Sub-division 1 at Duddell Street



Subject Storeroom with arch ceiling (Plate 39) **Date photograph taken** 07-Dec-07

Description The storeroom is stockpiled with miscellaneous items



Subject Storeroom with arch ceiling (Plate 40) **Date photograph taken** 07-Dec-07

Description The condition of the wooden door and glass window is considered fair

Job title Contract No. HY/2008/18

Job number: 24506

Location Feature No. 11SW-B/R93, Sub-division 1 at Duddell Street



Subject Storeroom with arch ceiling (Plate 41) **Date photograph taken** 07-Dec-07

Description The ceiling plaster is peeling off



Subject Storeroom with flat ceiling (Plate 42) **Date photograph taken** 04-Jan-11

Description View showing one of the storerooms with a black steel gate

Job title Contract No. HY/2008/18

Job number: 24506

Location Feature No. 11SW-B/R93, Sub-division 1 at Duddell Street



Subject Storeroom with flat ceiling (Plate 43) **Date photograph taken** 27-Nov-07

Description The storeroom is stockpiled with miscellaneous items



Subject Disused tunnel connected to Portal 43 (Plate 44) **Date photograph taken** 04-Jan-11

Description General view showing Portal 43

Job title Contract No. HY/2008/18

Job number: 24506

Location Feature No. 11SW-B/R93, Sub-division 1 at Duddell Street



Subject Disused tunnel connected to Portal 43 (Plate 45) **Date photograph taken** 21-Dec-07

Description A wooden ladder is leaning against the back of the tunnel



Subject Disused tunnel connected to Portal 43 (Plate 46) **Date photograph taken** 21-Dec-07

Description Seepage is observed from the masonry sidewalls

Job title Contract No. HY/2008/18

Job number: 24506

Location Feature No. 11SW-B/R93, Sub-division 1 at Duddell Street



Subject Disused tunnel connected to Portal 43 (Plate 47) **Date photograph taken** 21-Dec-07

Description Row of flat precast reinforced concrete lintels is observed at the ceiling



Subject Disused tunnel connected to Portal 43 (Plate 48) **Date photograph taken** 21-Dec-07

Description View showing a hole at the back wall of the tunnel

Job title Contract No. HY/2008/18

Job number: 24506

Location Feature No. 11SW-B/R93, Sub-division 1 at Duddell Street



Subject Disused tunnel connected to Portal 43 (Plate 49) **Date photograph taken** 21-Dec-07

Description Behind the backwall, the tunnel is filled with boulders and cement



Subject Disused tunnel connected to Portal 43 (Plate 50) **Date photograph taken** 21-Dec-07

Description The general condition of the tunnel is fair

Job title Contract No. HY/2008/18

Job number: 24506

Location Feature No. 11SW-B/R93, Sub-division 1 at Duddell Street

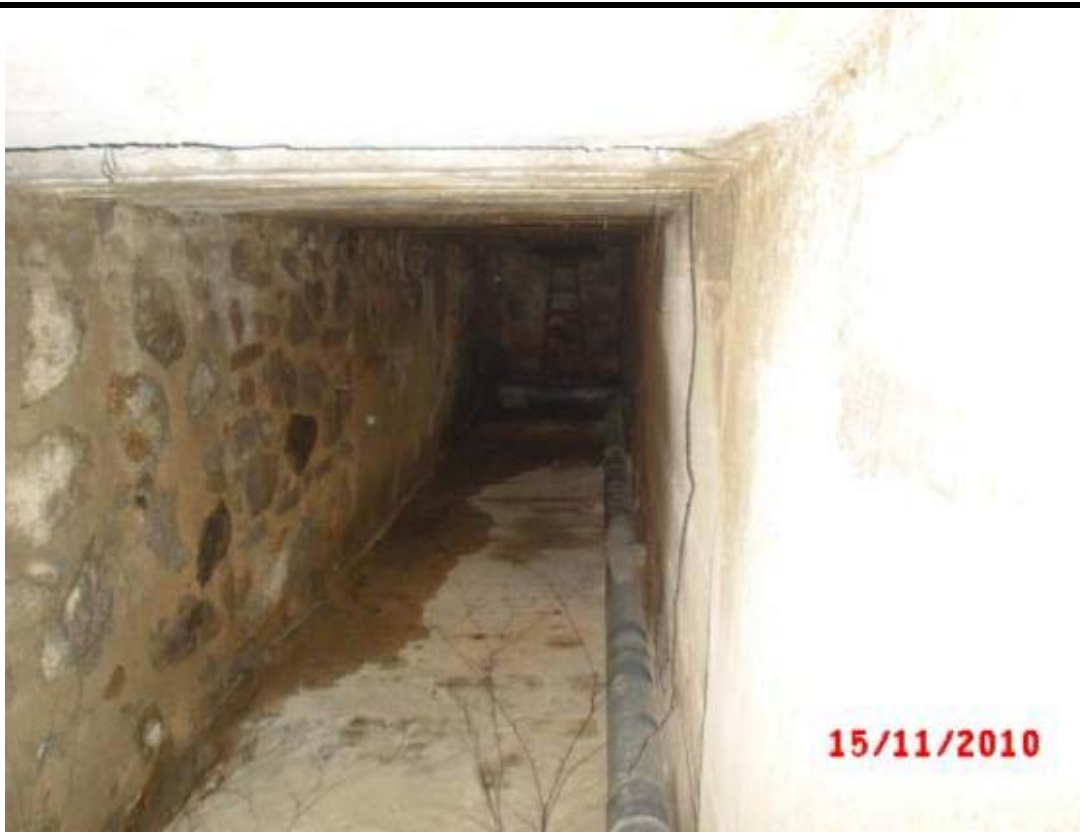

Subject Disused tunnel connected to Portal 43 (Plate 51) **Date photograph taken** 15-Nov-10

Description Tree roots are observed inside the tunnel



Subject Disused tunnel connected to Portal 44 (Plate 52) **Date photograph taken** 04-Jan-11

Description General view of Portal 44

Job title Contract No. HY/2008/18

Job number: 24506

Location Feature No. 11SW-B/R93, Sub-division 1 at Duddell Street



Subject Disused tunnel connected to Portal 44 (Plate 53) **Date photograph taken** 08-May-09

Description The entrance of Portal 44 is covered by corrugated steel plates



Subject Disused tunnel connected to Portal 44 (Plate 54) **Date photograph taken** 08-May-09

Description Behind the steel plate, the tunnel is locked by a steel gate

Job title Contract No. HY/2008/18

Job number: 24506

Location Feature No. 11SW-B/R93, Sub-division 1 at Duddell Street



Subject Disused tunnel connected to Portal 44 (Plate 55) **Date photograph taken** 08-May-09

Description The steel gate is corroded and in poor condition



Subject Disused tunnel connected to Portal 44 (Plate 56) **Date photograph taken** 08-May-09

Description The steel gate is corroded and in poor condition

Job title Contract No. HY/2008/18

Job number: 24506

Location Feature No. 11SW-B/R93, Sub-division 1 at Duddell Street



Subject Disused tunnel connected to Portal 44 (Plate 57) **Date photograph taken** 08-May-09

Description The steel gate is corroded and in poor condition



Subject Disused tunnel connected to Portal 44 (Plate 58) **Date photograph taken** 08-May-09

Description The entrance of th tunnel is blocked by tree roots

Job title Contract No. HY/2008/18

Job number: 24506

Location Feature No. 11SW-B/R93, Sub-division 1 at Duddell Street



Subject Disused tunnel connected to Portal 44 (Plate 59) **Date photograph taken** 08-May-09

Description The steel gate is corroded and in poor condition



Subject Disused tunnel connected to Portal 44 (Plate 60) **Date photograph taken** 08-May-09

Description Tree roots are growing inside the tunnel

Job title Contract No. HY/2008/18

Job number: 24506

Location Feature No. 11SW-B/R93, Sub-division 1 at Duddell Street



Subject Disused tunnel connected to Portal 44 (Plate 61) **Date photograph taken** 08-May-09

Description Row of flat precast reinforced concrete lintels is observed at the ceiling



Subject Disused tunnel connected to Portal 44 (Plate 62) **Date photograph taken** 08-May-09

Description Row of flat precast reinforced concrete lintels is observed at the ceiling

Job title Contract No. HY/2008/18

Job number: 24506

Location Feature No. 11SW-B/R93, Sub-division 1 at Duddell Street



Subject Disused tunnel connected to Portal 44 (Plate 63) **Date photograph taken** 08-May-09

Description Tree roots are growing along the ceiling inside the tunnel



Subject Disused tunnel connected to Portal 44 (Plate 64) **Date photograph taken** 08-May-09

Description Lots of empty glass bottles are placed on the floor

Job title Contract No. HY/2008/18

Job number: 24506

Location Feature No. 11SW-B/R93, Sub-division 1 at Duddell Street



Subject Feature No. 11SW-B/R93 (Plate 65) **Date photograph taken** 08-May-09

Description The entrance of th tunnel is blocked by tree roots



Subject Feature No. 11SW-B/R93 (Plate 66) **Date photograph taken** 08-May-09

Description The steel gate is corroded and in poor condition

Job title Contract No. HY/2008/18

Job number: 24506

Location Feature No. 11SW-B/R93, Sub-division 1 at Duddell Street



Subject Adjacent buildings - Baskerville House (Plate 67) **Date photograph taken** 04-Jan-11

Description A trapezoid steel gate is constructed adjacent to Backerville House



Subject Adjacent buildings - HKDEB (Plate 68) **Date photograph taken** 04-Jan-11

Description The condition of Hong Kong Diamond Exchange Building is good

Job title Contract No. HY/2008/18

Job number: 24506

Location Feature No. 11SW-B/R93, Sub-division 1 at Duddell Street



Subject Adjacent footpath/ pavement (Plate 69) **Date photograph taken** 04-Jan-11

Description View showing the footpath/ pavement adjacent to Baskerville House in good conditions



Subject Adjacent footpath/ pavement (Plate 70) **Date photograph taken** 04-Jan-11

Description A tread is constructed in front of the trapezoid steel gate

Job title Contract No. HY/2008/18

Job number: 24506

Location Feature No. 11SW-B/R93, Sub-division 1 at Duddell Street



Subject Existing utilities on the surface of the Feature (Plate 71) **Date photograph taken** 04-Jan-11

Description View showing numerous of utilities are installed on the north-western wall surface



Subject Existing utilities on the surface of the Feature (Plate 72) **Date photograph taken** 04-Jan-11

Description The brick wall covering some of the utilities are broken

Job title Contract No. HY/2008/18

Job number: 24506

Location Feature No. 11SW-B/R93, Sub-division 1 at Duddell Street



Subject Existing utilities on the surface of the Feature (Plate 73) **Date photograph taken** 04-Jan-11

Description Some utilities are constructed on the Feature and the exterior of Baskerville House



Subject Existing utilities on the surface of the Feature (Plate 74) **Date photograph taken** 04-Jan-11

Description Some air conditioners are installed on the exterior of Baskerville House

Job title Contract No. HY/2008/18

Job number: 24506

Location Feature No. 11SW-B/R93, Sub-division 1 at Duddell Street



Subject Existing utilities on the surface of the Feature (Plate 75) **Date photograph taken** 04-Jan-11

Description Some of the utilities are connected to the toe of the Feature



Subject Existing utilities on the surface of the Feature (Plate 76) **Date photograph taken** 04-Jan-11

Description Some of the utilities are connected to the toe of the Feature

Job title Contract No. HY/2008/18

Job number: 24506

Location Feature No. 11SW-B/R93, Sub-division 1 at Duddell Street



Subject Existing utilities on the surface of the Feature (Plate 77) **Date photograph taken** 04-Jan-11

Description A box channel is constructed at the Feature toe connected to a PVC from the tunnel



Subject Existing utilities on the surface of the Feature (Plate 78) **Date photograph taken** 04-Jan-11

Description View showing numerous of utilities are installed on the south-western wall surface

Job title Contract No. HY/2008/18

Job number: 24506

Location Feature No. 11SW-B/R93, Sub-division 1 at Duddell Street



Subject Existing wall trees (Plate 79) **Date photograph taken** 30-Oct-10

Description General view of the declared monuments and wall trees



Subject Existing wall trees (Plate 80) **Date photograph taken** 30-Oct-10

Description View showing the existing conditions of wall trees

Job title Contract No. HY/2008/18

Job number: 24506

Location Feature No. 11SW-B/R93, Sub-division 1 at Duddell Street



Subject Existing wall trees at the south-western side (Plate 81) **Date photograph taken** 30-Oct-10

Description View showing the existing conditions of wall tree at the south-western side of the Feature



Subject Existing wall trees at the south-western side (Plate 82) **Date photograph taken** 30-Oct-10

Description View showing the existing conditions of wall tree at the south-western side of the Feature

Job title Contract No. HY/2008/18

Job number: 24506

Location Feature No. 11SW-B/R93, Sub-division 1 at Duddell Street



Subject Existing wall trees at the south-western side (Plate 83) **Date photograph taken** 30-Oct-10

Description Tree roots are extended to the Hong Kong Diamond Exchange Building



Subject Existing wall trees at the south-western side (Plate 84) **Date photograph taken** 04-Jan-11

Description Apparent cracks formed by the tree is observed at the south-western parapet wall

Job title Contract No. HY/2008/18

Job number: 24506

Location Feature No. 11SW-B/R93, Sub-division 1 at Duddell Street



Subject Existing wall trees at the south-western side (Plate 85) **Date photograph taken** 04-Jan-11

Description Numerous of tree roots are observed at the crest of the Feature



Subject Existing wall trees at the south-western side (Plate 86) **Date photograph taken** 04-Jan-11

Description Tree roots are extended to the Hong Kong Diamond Exchange Building

Job title Contract No. HY/2008/18

Job number: 24506

Location Feature No. 11SW-B/R93, Sub-division 1 at Duddell Street



Subject Existing wall trees at the north-western side (Plate 87) **Date photograph taken** 30-Oct-10

Description View showing the existing conditions of wall tree at the north-western side of the Feature



Subject Existing wall trees at the north-western side (Plate 88) **Date photograph taken** 30-Oct-10

Description View showing the existing conditions of wall tree at the north-western side of the Feature

Job title Contract No. HY/2008/18

Job number: 24506

Location Feature No. 11SW-B/R93, Sub-division 1 at Duddell Street

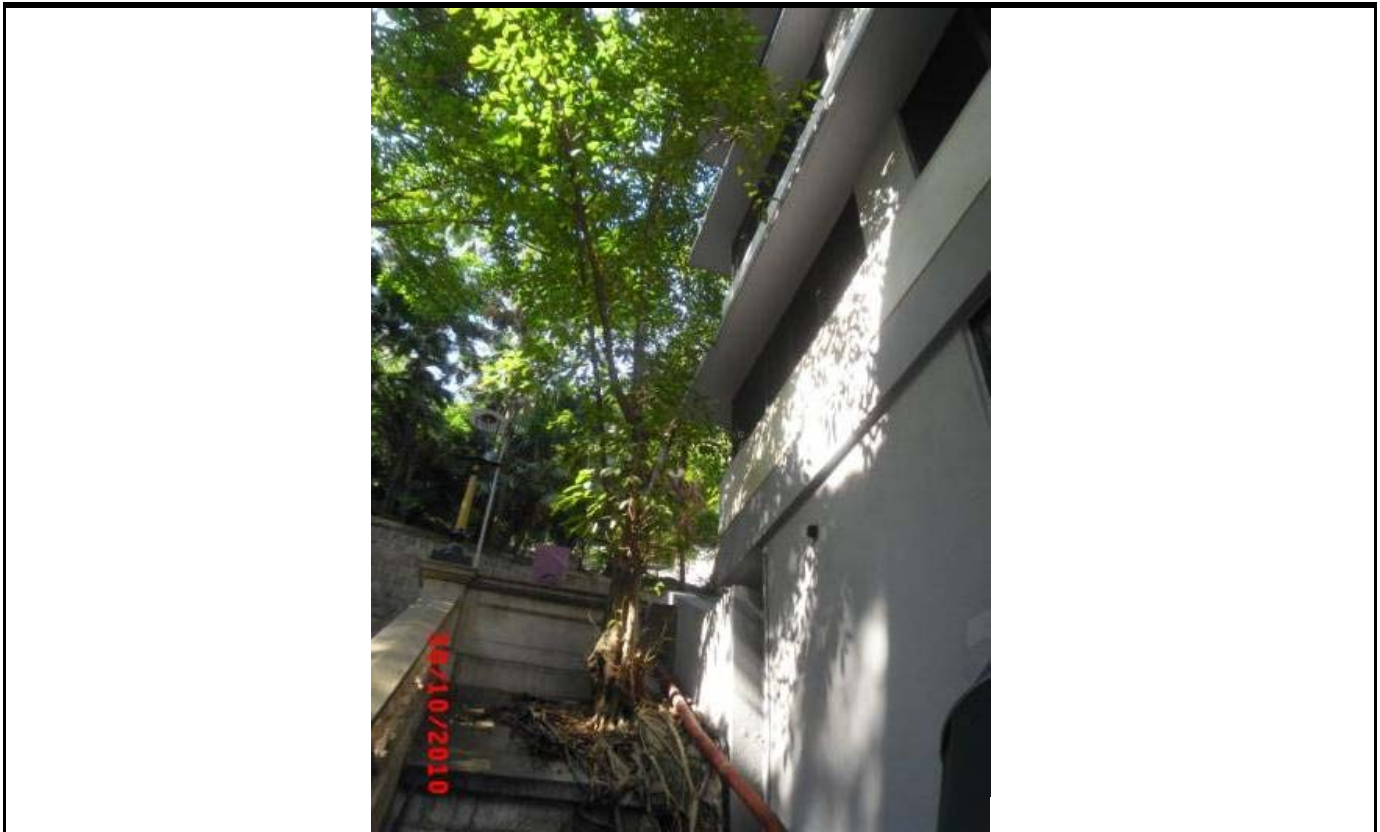

Subject Existing wall trees at the north-western side (Plate 89) **Date photograph taken** 30-Oct-10

Description Numerous of tree roots are observed at the crest of the Feature



Subject Existing wall trees at the north-western side (Plate 90) **Date photograph taken** 30-Oct-10

Description Tree roots are growing downwards towards the Feature toe

Job title Contract No. HY/2008/18

Job number: 24506

Location Feature No. 11SW-B/R93, Sub-division 1 at Duddell Street



Subject Existing wall trees at the north-western side (Plate 91) **Date photograph taken** 30-Oct-10

Description Some of the utilities are covered by the tree rotts



Subject Existing wall trees at the north-western side (Plate 92) **Date photograph taken** 30-Oct-10

Description Tree roots are growing between the counterforts

Job title Contract No. HY/2008/18

Job number: 24506

Location Feature No. 11SW-B/R93, Sub-division 1 at Duddell Street



Subject	Existing wall trees (Plate 93)	Date photograph taken	30-Oct-10
----------------	--------------------------------	------------------------------	-----------

Description	View showing the existing wall trees at Ice House Street
--------------------	--

Subject	Date photograph taken
----------------	------------------------------

Description

Appendix J

Agreement No. CE 32/2004 (GE)
Upgrading / Improvement of Roadside Slopes / Retaining Walls
on Hong Kong Island (2005 – 2008 Programme)
- Investigation, Design and Construction

Presentation to ACABAS

Feature No. 11SW-B/R93, Duddell Street

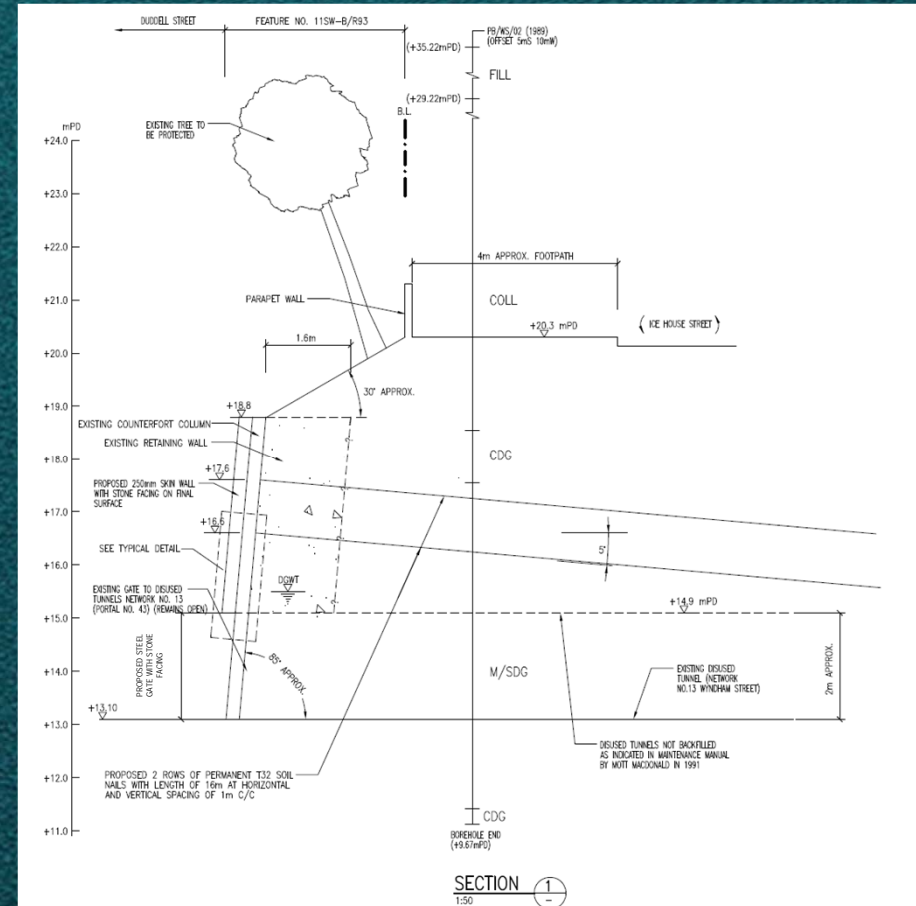
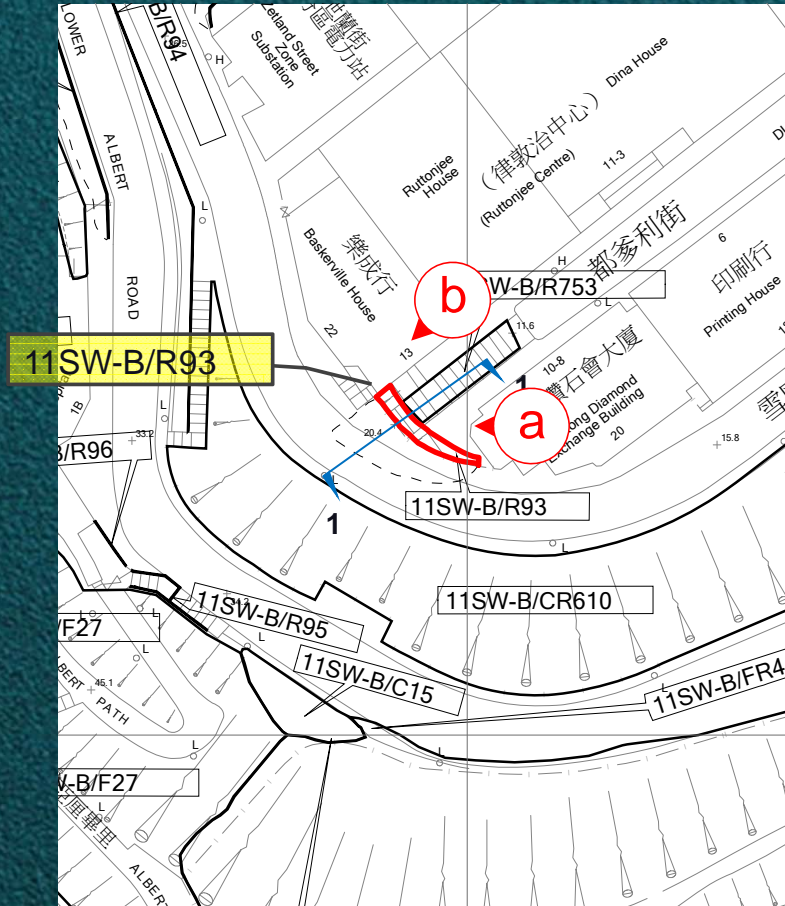

- Slope Height: max. 3.20m, Length: 17m
- Proposed upgrading works
 - Installation of soil nails and construction of skin wall
 - provision of stone facing with regular pattern

Feature No. 11SW-B/R93, Duddell Street

Before slope upgrading works (Section 1-1 General View of Feature)

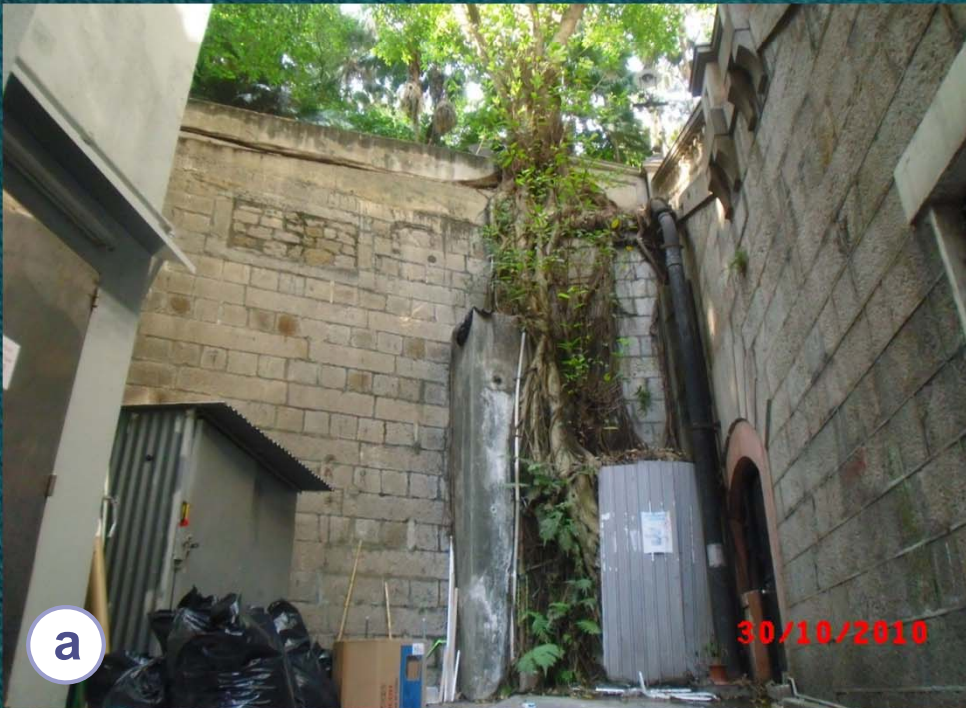

After slope upgrading works



Feature No. 11SW-B/R93
Stone facing with regular pattern

Feature No. 11SW-B/R93, Duddell Street

Before slope upgrading works



After slope upgrading works

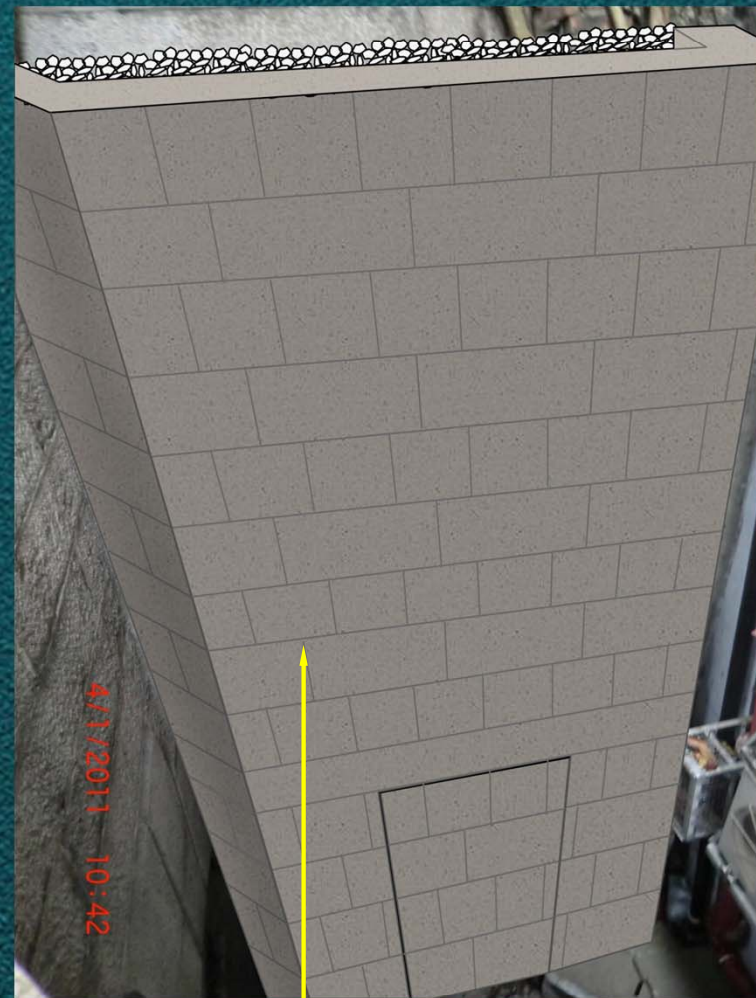

Feature No. 11SW-B/R93
Stone facing with regular pattern

DO NOT SCALE DRAWING. CHECK ALL DIMENSIONS ON SITE.

ALL RIGHTS RESERVED.

© OVE ARUP & PARTNERS HONG KONG LIMITED.

GENERAL NOTES

- ALL WORKS SHALL COMPLY WITH GENERAL SPECIFICATION FOR CIVIL ENGINEERING WORKS, 2006 EDITION (HONG KONG GOVERNMENT).
- THIS DRAWING SHALL BE READ IN CONJUNCTION WITH ALL OTHER RELEVANT DRAWINGS, STANDARD DRAWINGS, THE SPECIFICATIONS AND INSTRUCTIONS ISSUED BY THE ENGINEER.
- UNLESS SPECIFIED OTHERWISE, ALL DETAILS SHALL BE REFERRED TO THE LATEST VERSION OF CEDD AND HYD STANDARD DRAWINGS.
- ALL DIMENSIONS ARE IN MILLIMETRES UNLESS OTHERWISE SPECIFIED.
- ALL LEVELS ARE IN METRES ABOVE P.D.
- THE CONTRACTORS SHALL BE RESPONSIBLE TO MAINTAIN THE SLOPE SURFACE PROTECTION WORKS.
- THE CONTRACTOR SHALL BE RESPONSIBLE FOR THE TEMPORARY DIVERSION AND REINSTATEMENT AND ALL COORDINATION WORKS WITH THE UTILITY COMPANIES.
- THE EXACT BOUNDARY OF THE WORKS SITE AND THE WORKS AREA AND THE EXACT ALIGNMENT OF HOARDING, SAFETY FENCE AND CHAIN LINK FENCE SHALL BE CONFIRMED BY THE ENGINEER ON SITE.
- NO TREES SHALL BE FELLED WITHOUT THE APPROVAL OF THE ENGINEER IN WRITING.
- ADEQUATE TEMPORARY WORKS SHALL BE PROVIDED TO SUPPORT AND PROTECT TREES SPECIFIED TO BE PRESERVED FROM DAMAGES.
- PRIOR TO COMMENCEMENT OF WORKS, THE CONTRACTOR SHALL CONFIRM THE EXACT LOCATION OF THE EXISTING UTILITIES AT THE WORKS SITE BY TRIAL PITS.
- EXISTING CHANNELS AND CATCHPITS TO BE RETAINED SHALL BE MAINTAINED BY THE CONTRACTOR AND SHALL BE REPAIRED WHERE NECESSARY AS DIRECTED BY THE ENGINEER ON SITE.
- THE CONTRACTOR SHALL REPORT TO THE ENGINEER IMMEDIATELY IF ANY ADVERSE GEOLOGICAL OR GROUNDWATER CONDITION REVEALED DURING OR BEFORE THE CONSTRUCTION WORKS.
- WATER DISCHARGED DUE TO CONSTRUCTION ACTIVITIES SHALL BE PASSED THROUGH A SAND TRAP/SETTLEMENT TANK PRIOR TO DISCHARGING INTO THE PERMANENT DRAINAGE SYSTEM.
- GROUT OUTFLOW FROM SOIL NAIL DRILLHOLES SHALL NOT BE DISCHARGED INTO THE PERMANENT DRAINAGE SYSTEM.
- THE CONTRACTOR SHALL BE RESPONSIBLE FOR THE DESIGN AND EXECUTION OF ALL NECESSARY TEMPORARY WORKS. THE CONTRACTOR SHALL ALSO SUBMIT THE PROPOSAL FOR THE APPROVAL OF THE ENGINEER PRIOR TO COMMENCEMENT OF WORKS.
- THE CONTRACTOR SHALL CHECK THE JOINTS ORIENTATIONS AND STABILITY OF THE BOULDERS ON THE SLOPE SURFACE OF THE FEATURE AND CARRY OUT STABILIZATION MEASURES IN FORM OF MASS CONCRETE BUTTRESS OR ROCK DOWEL IF NECESSARY UNDER THE DIRECTION OF THE ENGINEER.
- THE CONTRACTOR SHALL ERECT DISPLAY SIGN PLATE FOR SLOPE REGISTRATION NUMBER ON SLOPE/RETAINING WALL.
- THE CONTRACTOR SHALL KEEP THE SITE IN A CLEAN AND HYGIENIC CONDITION. ALL SURPLUS MATERIAL AND RUBBISH OF ANY LAND WHATSOEVER AS THE CONTRACTOR ARISES SHALL BE KEPT AWAY AND REMOVE FROM THE WORKS AREA AND THE CORRESPONDING PUBLIC CLEANING AREAS, THE EXTENT OF WHICH SHALL BE CONFIRMED ON SITE BY THE ENGINEER.
- THE NOTES ON THIS DRAWING ARE THE GENERAL REQUIREMENTS UNLESS OTHERWISE SPECIFIED OR INSTRUCTED BY THE ENGINEER.

PRECAUTIONS AGAINST HEAVY RAINFALL

- PRIOR TO THE COMMENCEMENT OF ANY SLOPE UPGRADING WORKS, SURFACE WATER FLOWING INTO THE SITE FROM UPHILL SHALL BE INTERCEPTED AND SAFELY DISCHARGED FROM THE SITE.
- ALL UNPROTECTED PARTIALLY FORMED SOIL SLOPES MUST BE TEMPORARILY PROTECTED BY PLASTIC SHEETING, SUITABLY SECURED AGAINST THE WIND, AT THE END OF EACH DAY.
- THE CONTRACTOR SHALL NOT STOCKPILE MATERIAL THAT MAY CAUSE A LANDSLIDE WHICH ENDANGERS THE PUBLIC OR ANY PROPERTY.
- ALL EARTHWORKS SHALL BE GRADED AND SEALED TO ENSURE RUN-OFF AND TO AVOID PONDING.
- A METHOD OF WORK SHALL BE ADOPTED IN WHICH A MINIMUM OF BARE SLOPE IS EXPOSED AT ANY TIME. EARTHWORK TO FORM THE FINAL FACE SHALL BE IMMEDIATELY FOLLOWED WITH SURFACE PROTECTION AND DRAINAGE WORK.
- WHERE TEMPORARY BARE SLOPE FACES ARE UNAVOIDABLE, THEY SHALL BE PROTECTED WITH SHEETING WELL SECURED AGAINST THE WIND. WHEN THEY ARE TO BE EXPOSED FOR MORE THAN TWO WEEKS, TEMPORARY HARD SURFACING SHALL BE PROVIDED AND TEMPORARY DRAINS SHALL BE INSTALLED.

NOTES ON DRAINAGE WORKS

- ALL CONCRETE WORKS SHALL COMPLY WITH GENERAL SPECIFICATION FOR CIVIL ENGINEERING WORKS, 2006 EDITION (HONG KONG GOVERNMENT).
- ALL CONCRETE TO BE GRADE 20S/20 TO GENERAL SPECIFICATION FOR CIVIL ENGINEERING WORKS, 2006 EDITION (HONG KONG GOVERNMENT), EXCEPT FOR MANHOLES AND SANDTRAPS WHERE GRADE 30D/20 SHALL BE USED.
- THE DRAINAGE WORKS SHALL COMPLY WITH THE GENERAL SPECIFICATION FOR CIVIL ENGINEERING WORKS, 2006 EDITION (HONG KONG GOVERNMENT).
- DETAILS OF DRAINAGE CHANNEL AND CATCHPITS SHALL BE IN ACCORDANCE WITH CEDD STANDARD DRAWINGS C2409H, C2410G, C2411G, C2412D, C2413D, C2415D, C2405I, C2406I, C2407B AND C2408B.
- MINIMUM GRADIENT SHALL BE 1 IN 10 FOR SURFACE CHANNELS ON SLOPE FACE, 1 IN 100 FOR OTHER SURFACE CHANNELS AND 1 IN 20 FOR STEPPED CHANNELS OR OTHERWISE STATED OR AS DIRECTED BY ENGINEER ON SITE.
- EXISTING CHANNELS AND CATCHPITS TO BE RETAINED SHALL BE MAINTAINED BY THE CONTRACTOR AND SHALL BE REPAIRED WHERE NECESSARY AS DIRECTED BY THE ENGINEER ON SITE.

PROTECTION OF EARTHWORKS

- ALL EARTHWORKS SHALL BE GRADED AND SEALED TO ENSURE RUN-OFF AND TO AVOID PONDING.
- A METHOD OF WORKING SHALL BE ADOPTED IN WHICH THE MINIMUM OF BARE SOIL IS EXPOSED AT ANY TIME. EARTHWORK TO FORM THE FINAL FACE SHALL BE FOLLOWED UP IMMEDIATELY WITH SURFACE PROTECTION.
- WHERE TEMPORARY BARE SLOPE FACES ARE UNAVOIDABLE, THEY SHALL BE PROTECTED WITH SHEETING SECURED AGAINST THE WIND. WHERE SLOPE FACES ARE TO BE TEMPORARILY EXPOSED FOR MORE THAN TWO WEEKS, TEMPORARY HARD SURFACING SHALL BE PROVIDED AND TEMPORARY DRAINS SHALL BE INSTALLED.
- IF TRENCHES OR ADJACENT TO SLOPE HAVE TO BE EXCAVATED DURING THE WET SEASON, THIS SHALL BE DONE WITH EXTREME CARE IN SHORT SECTIONS AT A TIME. PRECAUTION SHALL BE TAKEN TO PREVENT WATER ENTERING AND ACCUMULATING IN THE TRENCH.
- EARTHWORKS SHALL BE SEALED TO THE SATISFACTION OF THE ENGINEER TO PREVENT INFILTRATION AND EROSION.
- EXCAVATION WORKS FOR ANY SECTION OF A TRENCH FOR TEMPORARY/PERMANENT DRAINAGE WORKS SHALL NOT COMMENCE UNTIL THE NATURE, LOCATION AND SIZE OF EXISTING UTILITIES WHICH MAY BE AFFECTED BY THE EXCAVATION HAVE BEEN ASCERTAINED AND THE SETTING OUT DETAILS HAVE BEEN APPROVED BY THE ENGINEER.
- THE CONTRACTOR SHALL ALLOW THE ENGINEER TO INSPECT TRENCHES, BEDDING, PIPES, JOINTS, FITTINGS AND VALVES BEFORE DRAINAGE WORKS STARTS. THE CONTRACTOR SHALL INFORM THE ENGINEER 24 HOURS OR SUCH SHORTER PERIOD AGREED BY THE ENGINEER, BEFORE TEMPORARY/PERMANENT DRAINAGE WORKS STARTS IN ANY PART OF THE WORKS.
- NEITHER STOCK PILING ON THE SLOPE NOR THE CEMENT IS PERMITTED WITHOUT APPROVAL FROM THE ENGINEER.

NOTES ON DRILLING RECORDS

- THE CONTRACT IS REQUIRED TO PROVIDE RECORDS OF DRILLING FOR ALL PULL-OUT TEST SOIL NAILS AND AS DIRECTED BY THE ENGINEER.
- DRILLING RECORDS SHALL INCLUDE THE LOCATION PLAN, LEVELS, NUMBER OF DRILLHOLES, TIME AND DATE OF DRILLING, WEATHER, OBSERVATION DURING DRILLING, DRILLING RATE IN MINUTES PER METER AND DESCRIPTION OF THE DRILLED MATERIALS BASED ON THE FLUSHED OUT MATERIALS COLLECTED DURING DRILLING FOR EVERY METER OF DRILLING THE HOLE.
- DRILLING RECORDS SHALL BE PREPARED AND SUBMITTED TO THE ENGINEER WITHIN 48 HOURS AFTER COMPLETION OF DRILLING OF THE HOLES. THE CONTENTS OF THE DRILLING RECORDS SHALL BE PRESENTED IN POINT FORM, GRAPHICAL AND TABLE FORM AS AGREED BY THE ENGINEER PRIOR TO SUBMISSION.
- WHEN INSTRUCTED BY THE ENGINEER, THE FLUSHED OUT MATERIALS SHALL BE COLLECTED IN PLASTIC BAGS WITH LABELS SHOWING THE DATE, DEPTH AND DRILLHOLE NUMBER AND KEPT ON SITE IN A PROPER MANNER FOR THE ENGINEER'S EXAMINATION.

GENERAL NOTES ON SOIL NAILS

- SOIL NAIL SETTING OUT DATA IS TENTATIVE ONLY. BEFORE SOIL NAIL INSTALLATION, THE POSITION OF EACH SOIL NAIL SHALL BE MARKED ON THE SLOPE FACE FOR THE ENGINEER'S VERIFICATION.
- ORIENTATION OF SOIL NAILS SHALL BE NORMAL TO THE TOE LINE UNLESS OTHERWISE INSTRUCTED BY THE ENGINEER.
- DETAILS OF SOIL NAIL INSTALLATION AND SOIL NAIL HEAD SHALL BE IN ACCORDANCE WITH CEDD STANDARD DRAWINGS C2106/1I, C2106/2F, C2106/3F.
- MINIMUM 2 NUMBERS OF PULL-OUT TEST OR 2% OF THE TOTAL NUMBER OF SOIL NAILS, WHICHEVER THE GREATER TO BE TESTED PRIOR TO THE INSTALLATION OF THE PERMANENT SOIL NAILS.
- PULL-OUT TEST LOCATIONS ARE TENTATIVE ONLY. THE EXACT LOCATIONS OF PULL-OUT TESTS SHALL BE CONFIRMED BY THE ENGINEER ON SITE.
- POSITION OF SOIL NAILS SHALL BE ADJUSTED WHERE NECESSARY ON SITE TO AVOID DAMAGE TO EXISTING TREES INCLUDING BRANCHES AND ROOTS.
- SOIL NAILS TO BE PROVIDED AT 1.5m CENTRE-TO-CENTRE SPACING AND INCLINED AT 5° WITH THE HORIZONTAL UNLESS STATED OTHERWISE.
- THE DIAMETER OF SOIL NAILS SHALL REFER TO THE SOIL NAIL SCHEDULE. DETAILS SHALL REFER TO CEDD STANDARD DRAWING C2106/1H.
- THE MINIMUM DIAMETER OF DRILLHOLES FOR SOIL NAIL INSTALLATION TO BE 150mm. THE SOIL NAILS SHALL BE INSTALLED WITHIN 72 HOURS OF COMPLETION OF THE DRILLING UNLESS OTHERWISE AGREED.
- DRILLHOLES SHALL BE CLEARED OF ALL DEBRIS AND STANDING WATER IMMEDIATELY BEFORE GROUTING BY AIR FLUSHING.
- ALL SOIL NAIL BARS AND STEEL REINFORCEMENT FOR SOIL NAIL HEADS SHALL BE HIGH TENSILE STEEL BAR WITH YIELD STRESS OF 460N/mm² TO CS2:1995.
- ALL STEEL COMPONENTS TO BE HOT DIP GALVANIZED TO BS EN ISO 1461:1999.
- CEMENT GROUT SHALL HAVE A 28 DAY CUBE STRENGTH OF 30N/mm² AND WATER CEMENT RATIO SHALL NOT EXCEED 0.45. CEMENT GROUT CUBES SHALL BE 100mm CUBES TESTED IN ACCORDANCE WITH THE GENERAL SPECIFICATION FOR CIVIL ENGINEERING WORKS, 2006 EDITION (HONG KONG GOVERNMENT).
- CEMENT GROUT SHALL BE DISCHARGED FROM THE BOTTOM OF DRILLHOLE BY MEANS OF A GROUT PIPE. GROUTING SHALL CONTINUE UNTIL GROUT OF THE SAME COMPOSITION AND CONSISTENCY AS THAT MIXED HAS BEEN EMERGING FOR AT LEAST ONE MINUTE.
- NAIL HEAD NUTS SHALL BE OF GRADE 4.6 STEEL AND COMPLY WITH BS4190:2001.
- BEARING PLATES SHALL BE OF GRADE 43A STEEL PLATE AND COMPLY WITH BS 4360.
- HOLES IN STEEL PLATES FOR SOIL NAIL HEADS SHALL BE DRILLED PERPENDICULAR TO THE FACE OF THE STEEL PLATE AND THE CENTRE OF THE HOLE SHALL BE WITHIN 2mm FROM THE CENTROID OF THE PLATE. THE CLEARANCE BETWEEN THE STEEL BAR AND THE HOLE OF THE STEEL PLATE SHALL NOT BE MORE THAN 2mm.
- DRILLING FOR SOIL NAILS SHALL BE CARRIED OUT USING CONCENTRIC OVERBURDEN DRILLING METHOD WITH CASING AND THE FORM AS FLUSHING MEDIUM FOR DRILLING MEDIUM, UNLESS OTHERWISE AGREED BY THE ENGINEER. DRILLING RIGS / HAND CORING RIGS SHALL BE PLACED ON SECURE TEMPORARY PLATFORMS, SCAFFOLDING OR MOBILE PLATFORM.
- WHENEVER ROCKHEAD IS ENCOUNTERED DURING SOIL NAIL DRILLING, THE ENGINEER SHOULD BE PROMPTLY INFORMED SO THAT ARRANGEMENT SHALL BE MADE FOR THE ENTIRE PROCESS OF SOIL NAIL DRILLING IN ROCK TO BE WITNESSED BY DESIGNATED PERSONNEL BY THE ENGINEER.
- THE PERMITTED DEVIATION OF DRILLHOLES SHALL BE ±2° TO THE SPECIFIED VERTICAL AND HORIZONTAL ALIGNMENT.
- SOIL NAIL SHALL BE GROUTED IMMEDIATELY AFTER INSERTION INTO THE DRILLHOLES AND SHALL BE GROUTED OVER THEIR WHOLE LENGTH IN ONE SINGLE OPERATION.
- WITHIN 12 HOURS OF THE COMPLETION OF GROUTING, NO DRILLHOLE SHALL BE CARRIED OUT WITHIN A 10 METRES RADIUS ZONE OF ANY FRESHLY GROUTED SOIL NAIL.
- CONCRETE FOR SOIL NAIL HEADS SHALL BE OF GRADE 30/20 OR SPRAYED CONCRETE WITH A MINIMUM COMPRESSIVE STRENGTH OF CONCRETE CORE, CONVERTED TO ESTIMATED EQUIVALENT CUBE STRENGTH OF 30MPa AT 28 DAYS IN ACCORDANCE WITH BS6089.
- FOR SOIL NAILS USING THREADED TYPE REINFORCEMENT CONNECTORS BUT WITHOUT HOT-DIP GALVANIZED COATING ON EITHER THE THREAD INSIDE THE CONNECTORS OR THE THREADS AT THE ENDS OF REINFORCEMENT BARS, HEAT-SHRINKABLE SLEEVE OF A PROPRIETARY TYPE AS APPROVED BY THE ENGINEER SHALL BE USED AS AN ALTERNATIVE TO HOT-DIP GALVANIZATION AS A CORROSION PROTECTION MEASURE TO THE CONNECTORS.
- THE PROPERTIES OF THE HEAT-SHRINKING SLEEVE TO CONNECTORS SHALL COMPLY WITH THE REQUIREMENTS AS STIPULATED IN THE SPECIFICATION OF THE CONTRACT.

PROTECTION AND PRESERVATION OF EXISTING TREES, DISUSED TUNNEL AND DUDDLELL STREET STEPS AND GAS LAMPS (DECLARED MONUMENT)

- NO TREE SHALL BE FELLED WITHOUT THE APPROVAL OF THE ENGINEER IN WRITING.
- ADEQUATE TEMPORARY WORKS SHALL BE PROVIDED TO SUPPORT AND PROTECT TREES SPECIFIED TO BE PRESERVED FROM DAMAGE IN ACCORDANCE WITH THE SPECIFICATIONS.
- AS AGREED OR DIRECTED BY THE ENGINEER, ALIGNMENT OF HOARDING, FENCING, NEW CHANNELS AND MAINTENANCE STAIRWAY/WALKWAY SHALL BE ADJUSTED ON SITE TO AVOID DAMAGE TO EXISTING TREES.
- THE CONTRACTOR SHALL CONFIRM THE LOCATIONS OF, CHECK, RECORD AND TAKE PHOTOS OF THE CONDITIONS OF THE EXISTING TREES WITHIN THE WORKS SITE AND WORKS AREA. A REPORT OF THE CONDITIONS OF THE EXISTING TREES, INCLUDING COLOUR PHOTOS, PLAN OF LOCATIONS AND BRIEF DESCRIPTIONS OF ANY DEFECTS OR DAMAGE OF TREES OBSERVED, SHALL BE SUBMITTED TO THE ENGINEER FOR RECORD AT LEAST 2 WEEKS PRIOR TO COMMENCEMENT OF THE WORKS.
- EXISTING TREES SHALL BE RETAINED AS INSTRUCTED BY THE ENGINEER ON SITE.
- ADEQUATE TEMPORARY PROTECTION WORKS SHALL BE PROVIDED TO PROTECT THE DUDDLELL STREET STEPS AND GAS LAMPS (DECLARED MONUMENT) FROM DAMAGE DURING THE CONSTRUCTION PERIOD. THE CONTRACTOR SHALL ALSO SUBMIT THE PROPOSAL FOR THE APPROVAL OF THE ENGINEER PRIOR TO COMMENCEMENT OF WORKS.
- INITIAL CONDITIONAL SURVEY FOR THE DISUSED TUNNEL SHOULD BE CARRIED OUT AND SUBMIT TO THE ENGINEER PRIOR TO COMMENCEMENT OF WORKS.
- FINAL CONDITIONAL SURVEY FOR THE DISUSED TUNNEL SHOULD BE CARRIED OUT AND SUBMIT TO THE ENGINEER AFTER THE UPGRADING WORKS COMPLETED.

NOTES ON MONITORING WORKS

- FOR THE LOCATION OF ALL MONITORING INSTRUMENTS, REFER TO DRAWING NO. 24506/BR93/UI03. EXACT LOCATION OF ALL MONITORING INSTRUMENTATION SHALL BE AGREED WITH THE ENGINEER ON SITE.
- DETAILS FOR GROUND SETTLEMENT MARKER SHALL REFER TO CEDD STD DRG NO. C2512A AND BUILDING SETTLEMENT MARKER AND UTILITY SETTLEMENT MARKER SHALL REFER TO DRAWING NO. 24506/BR93/UI04.
- THE AS-BUILT LOCATIONS OF ALL MONITORING INSTRUMENTS INCLUDING CO-ORDINATES, LEVELS AND PHOTOGRAPHS SHALL BE SUBMITTED TO THE ENGINEER FOR RECORD.
- DETAILS OF SETTING OUT CONTROL POINTS, BENCH MARKS, TEMPORARY BENCH MARKS ETC. USED FOR SETTLEMENT MONITORING SHALL BE SUBMITTED TO THE ENGINEER FOR AGREEMENT PRIOR TO START OF SURVEY WORK.
- THE CONTRACTOR SHALL BE RESPONSIBLE FOR THE MAINTENANCE OF THE MONITORING POINTS DURING CONSTRUCTION. ANY DAMAGED INSTRUMENTS SHALL BE REINSTATED OR REPLACED BY THE CONTRACTOR, AS DIRECTED BY THE ENGINEER.
- A COMPLETE RECORD OF MONITORING READINGS IN BOTH TABULATED AND GRAPHICAL FORMATS TO BE AGREED WITH THE ENGINEER SHALL BE CONTINUOUSLY UPDATED AND KEPT IN THE SITE OFFICE BY THE CONTRACTOR FOR INSPECTION BY THE ENGINEER UPON REQUEST AT ANY TIME.
- THE MONITORING WORKS SHALL BE CARRIED OUT ON A DAILY BASIS AND THE RESULTS IN BOTH TABULATED AND GRAPHICAL FORMATS SHALL BE SUBMITTED TO THE ENGINEER FOR REVIEW ON A WEEKLY BASIS.
- SHOULD UNDUE SETTLEMENT BE OBSERVED AT ANY OF THE MONITORING POINTS. ALL WORKS SHALL BE CEASED AND THE ENGINEER TO BE INFORMED IMMEDIATELY. REMEDIAL WORK PROPOSAL SHALL BE SUBMITTED TO THE ENGINEER FOR APPROVAL PRIOR TO THE RESUMPTION OF WORKS.
- IF EXISTING CRACKS ARE IDENTIFIED DURING INITIAL CONDITION SURVEY, TELL-TALES SHALL BE INSTALLED TO MONITOR THE CRACK WIDTH.
- ALERT AND ACTION LEVELS FOR INSTRUMENT READINGS ARE AS FOLLOWS:

	ALERT LEVEL	ACTION LEVEL
GROUND MOVEMENT	10mm	15mm
CRACK WIDTH INCREMENT	3mm	5mm
BUILDING SETTLEMENT	8mm	13mm
UTILITIES SETTLEMENT	8mm	13mm

- ON REACHING AN 'ALERT LEVEL' AT ANY LOCATION, THE CONTRACTOR SHALL SUBMIT TO THE ENGINEER A REPORT REVIEWING THE GROUND MOVEMENTS AND PREDICTING FURTHER GROUND MOVEMENTS AND ITS EFFECTS ON THE STRUCTURES ADJACENT TO CONTRACTOR SHALL PROPOSE APPROPRIATE REMEDIAL MEASURES TO LIMIT FURTHER MOVEMENTS. UPON APPROVAL BY THE ENGINEER, SUCH REMEDIAL MEASURES SHALL BE IMPLEMENTED BY THE CONTRACTOR.
11. WORKS SHALL ONLY BE RESUMED WITH THE APPROVAL OF THE ENGINEER UPON SATISFACTORY COMPLETION OF THE REMEDIAL MEASURES. IF FOUND NECESSARY, THE CONTRACTOR SHALL ADOPT ALTERNATIVE CONSTRUCTION METHOD TO ACCOMPLISH THE REMAINING WORKS.

NOTES ON PULL-OUT TESTS

- SOIL NAIL FOR PULL-OUT TESTS SHALL BE INSTALLED AND TESTED PRIOR TO THE INSTALLATION OF PERMANENT SOIL NAILS AS DIRECTED BY THE ENGINEER. SOIL NAILS SUBJECTED TO PULL-OUT TESTS SHALL NOT FORM PART OF THE PERMANENT WORKS. THE APPARATUS FOR MEASURING LOADS AND DEFORMATIONS SHALL HAVE AN ACCURACY OF 5kN AND 0.05mm RESPECTIVELY. THE APPARATUS FOR MEASURING DEFORMATION SHALL BE CAPABLE OF MEASURING A DISPLACEMENT OF UP TO 50mm. THE APPARATUS SHALL BE TESTED AND NOT MORE THAN 6 MONTHS PRIOR TO THE DATE OF CARRYING OUT THE TESTS. TEST AND CALIBRATION CERTIFICATES SHALL BE SUBMITTED TO THE ENGINEER AT LEAST ONE WEEK BEFORE THE TEST. DRILLING RECORDS OF HOLES SELECTED FOR PULL-OUT TESTS SHALL BE PROVIDED TO THE ENGINEER WITHIN 24 HOURS AFTER DRILLING. THE FOLLOWING PROCEDURE SHALL BE ADOPTED: -
 - THE SOIL NAIL SHALL BE GROUTED OVER THE LENGTH AS SPECIFIED IN THE DRAWINGS OR AS DIRECTED BY THE ENGINEER. THE LENGTH TO BE GROUTED SHALL BE ISOLATED BY MEANS OF A GROUT SEPARATOR THAT CAN PROTECT THE FREE-LENGTH SECTION FROM BEING CONTAMINATED BY THE GROUT AND THAT CAN ENSURE THAT THE PROPOSED BONDED SECTION IS EFFECTIVELY GROUTED TO THE REQUIRED LENGTH AS SHOWN IN THE DRAWING. THE SIZE OF THE SEPARATOR SHALL BE COMPATIBLE WITH THE DIAMETER OF THE DRILLHOLE. THE ENTIRE FREE LENGTH OF THE STEEL BAR SHALL BE PROPERLY DEBONDED OR CAPPED TO ENSURE THAT THE TEST LOAD CAN BE DIRECTLY TRANSFERRED TO THE BONDED ZONE IN CASE OF GROUT LEAK THROUGH THE SEPARATOR. THE PULL-OUT TEST SHALL NOT BE CARRIED OUT UNTIL THE GROUT HAS REACHED A CUBE STRENGTH OF 21MPa.
 - THE TEST LOAD (T_p) SHALL BE 90% OF THE YIELD STRENGTH OF THE STEEL BAR FORMING THE SOIL NAIL UNLESS OTHERWISE DIRECTED BY THE ENGINEER.
 - AN INITIAL LOAD (T_0) NOT GREATER THAN 5% OF T_p SHALL BE APPLIED. THE TEST NAIL SHALL BE LOADED UP IN STAGES. FROM THE INITIAL LOAD TO VIA TWO INTERMEDIATE TEST LOADS, TDL1 AND TDL2, TO THE MAXIMUM TEST LOAD T_p .
 - TDL1 AND TDL2 ARE THE LOADS THAT RESULT IN THE BONDED ZONE TESTED TO THE DESIGN WORKING BOND STRENGTH AND 2 TIMES THE WORKING BOND STRENGTH RESPECTIVELY. T_0 SHALL BE LESS THAN TDL1 AS SPECIFIED BY THE DESIGN ENGINEER.
 - A PROGRAMME OF THREE LOADING AND UNLOADING CYCLES SHALL THEN BE CARRIED OUT WITH THE LOAD BEING INCREASED FROM T_0 IN SUCCESSIVE CYCLES BY TDL1, TDL2 AND UP TO T_p . AFTER THE PEAK LOADING IN EACH CYCLE IS REACHED, MEASUREMENTS OF THE DEFORMATION INCREASE WITH THE LOAD HELD CONSTANT SHALL BE TAKEN AT TIME INTERVALS OF 1, 3, 6, 10, 20, 30, 40, 50 AND 60 MINUTES. WHEN REQUIRED, THE LOAD SHALL BE HELD LONGER AS DIRECTED BY THE ENGINEER.
 - WHEN THE DIFFERENCE OF NAIL MOVEMENTS AT 6 AND 60 MINUTES IS LESS THAN 2mm (OR 0.1% OF THE GROUTED LENGTH OF THE TEST NAIL), THE TEST NAIL IS CONSIDERED TO HAVE SUSTAINED THE TEST LOAD AND REACHED A STEADY STATE. THE TEST SHALL PROCEED TO THE NEXT LOADING CYCLE. IF AT ANY LOAD INCREMENT THE NAIL CANNOT SUSTAIN THE TEST LOAD, THE TEST SHALL BE TERMINATED AND THE FINAL NAIL MOVEMENT AND RESIDUAL LOAD SHALL BE RECORDED.
 - AFTER THE ABOVE MEASUREMENTS HAVE BEEN TAKEN FOR EACH CYCLE, THE LOAD SHALL BE REDUCED TO T_0 AND THE EXTENSION SHALL BE RECORDED. WHERE REQUIRED THE WHOLE SOIL NAIL SHALL BE PULLED OUT FROM THE DRILLHOLE FOR THE ENGINEER'S INSPECTION, UNLESS OTHERWISE INSTRUCTED BY THE ENGINEER. THE DRILLHOLE SHALL BE FILLED BY GROUTING.
 - IF THE SOIL NAIL CANNOT BE PULLED OUT WITHOUT EXCEEDING THE MAXIMUM ALLOWABLE TEST LOAD SPECIFIED IN (B), THEN THE BAR SHALL BE CUT-OFF, FLUSH WITH THE FINISHED GROUND AND THE REMAINING PART OF THE DRILLHOLE GROUTED.
 - THROUGHOUT THE TEST, THE SOIL NAIL MOVEMENT VERSUS THE APPLIED LOAD SHALL BE MEASURED, PLOTTED ON A GRAPH AND RECORDED ALONG WITH ALL OTHER RELEVANT INFORMATION, ON THE ATTACHED FORMS. ALL THE RESULTS SHALL BE SUBMITTED TO THE ENGINEER WITHIN 3 DAYS OF COMPLETION OF THE TEST.
- THE PULL-OUT TEST/ADDITIONAL TEST SHALL BE TERMINATED WHEN ONE OF THE FOLLOWING OCCURS:
 - THE TEST NAIL FAILS TO SUSTAIN THE TEST LOAD AND THE NAIL IS PULLED OUT;
 - WHEN THE TEST NAIL IS UNDER MAINTAINED LOAD (TDL1, TDL2 OR T_p), THE DIFFERENCE OF NAIL MOVEMENTS AT 6 AND 60 MINUTES EXCEEDS 2mm (OR 0.1% OF THE GROUTED LENGTH OF THE TEST NAIL); OR
 - THE MAXIMUM TEST LOAD (90% OF THE YIELD STRENGTH OF THE STEEL BAR) IS SUSTAINED. IF THE TEST IS TERMINATED BEFORE THE TEST LOAD TDL2 IS SUSTAINED, ADDITIONAL TESTS ARE REQUIRED.

THE ENGINEER MAY ORDER ADDITIONAL TESTS; THE NUMBER SHALL BE CALCULATED BY THE APPLICATION OF THE FORMULA GIVEN BELOW AND NO EXTENSION OF TIME WILL BE ALLOWED.

$$\text{NUMBER OF ADDITIONAL TESTS REQUIRED} = n^2 - 2n + 3$$

WHERE n = TOTAL NUMBER OF UNSUCCESSFUL TESTS

 - THE ADDITIONAL TEST NAILS SHALL BE INSTALLED NEAR TO THE UNSUCCESSFUL TEST NAIL OR AS DIRECTED BY THE ENGINEER.

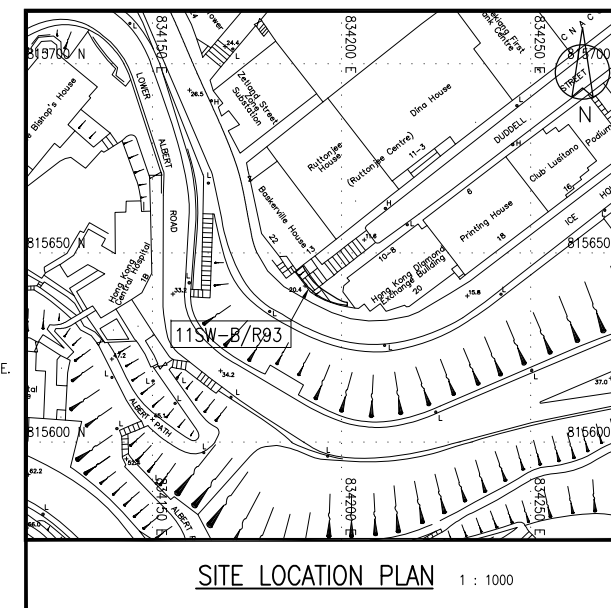

SITE LOCATION PLAN 1 : 1000

NOTES ON NON-DESTRUCTIVE TEST (NDT) FOR SOIL NAILS

- TIME DOMAIN REFLECTOMETRY (TDR) TESTS FOR THE PERMANENT SOIL NAILS SHALL BE CARRIED OUT. DETAILS OF TDR INSTALLATION SHALL BE IN ACCORDANCE WITH SKETCH NO. C2106/1I.
- A CONTROL NAIL SHALL BE SELECTED BY THE ENGINEER FOR CALIBRATION OF THE TDR TEST.
- THE EXACT LOCATIONS OF ALL TDR TESTS SHALL BE CONFIRMED BY THE ENGINEER ON SITE. A MINIMUM OF 5 NUMBERS OF TDR TESTS OR 1% OF THE TOTAL NUMBER OF SOIL NAILS, WHICHEVER IS GREATER, SHALL BE CARRIED OUT.
- TDR TEST SHALL NOT BE CARRIED OUT WITHIN 3 DAYS AFTER COMPLETION OF GROUTING.
- THE TESTING PROCEDURE AND INTERPRETATION OF TEST RESULTS SHALL BE CARRIED OUT IN ACCORDANCE WITH GEO REPORT NO. 133.
- TDR TEST SHALL BE CARRIED OUT BY AN INDEPENDENT LABORATORY AND A REPORT WITH THE TEST RESULTS AND INTERPRETATIONS SHALL BE SUBMITTED TO THE ENGINEER FOR ACCEPTANCE.

NOTES ON CONCRETE WORKS AND REINFORCEMENT DETAILS

- CONCRETE FOR SOIL NAILS HEADS, SKIN WALLS, REINFORCED CONCRETE SLABS OR GRILLAGE BEAMS SHALL BE OF GRADE 30/20 OR SPRAYED CONCRETE WITH A MINIMUM COMPRESSIVE STRENGTH OF CONCRETE CORES, CONVERTED TO ESTIMATED EQUIVALENT CUBE STRENGTH OF 30MPa AT 28 DAYS IN ACCORDANCE WITH BS 6089.
- CONCRETE FOR BACKFILLING VOIDS OR OTHER STRUCTURES THAN THAT IN SUB-ITEM 1 ABOVE SHALL BE OF GRADE 20/20 OR SPRAYED CONCRETE WITH A MINIMUM COMPRESSIVE STRENGTH OF CONCRETE CORES, CONVERTED TO ESTIMATED EQUIVALENT CUBE STRENGTH OF 20MPa AT 28 DAYS IN ACCORDANCE WITH BS 6089.
- MINIMUM LAP LENGTH FOR HIGH YIELD TYPE 2 DEFORMED BARS SHALL BE 40D, WHERE D IS THE DIAMETER OF THE SMALLER LAPPED BAR.
- ALL CONCRETE COVER TO THE OUTERMOST REINFORCEMENT SHALL BE 50mm.
- ALL EXPOSED CONCRETE CORNERS AND EDGES SHALL BE 25X25mm CHAMFERED.
- SURFACE FINISHES TO CONCRETE SHALL BE U1 AND F2 FOR BURIED SURFACE, U5 AND F3 FOR EXPOSED SURFACE.
- DETAILS OF MOVEMENT/EXPANSION JOINT REQUIRED FOR CONCRETE STRUCTURES OR SPRAYED CONCRETE SHALL BE IN ACCORDANCE WITH STANDARD DRAWING (WITHOUT WATER STOP).
- BAR MARKING SYSTEM OF REINFORCEMENT:

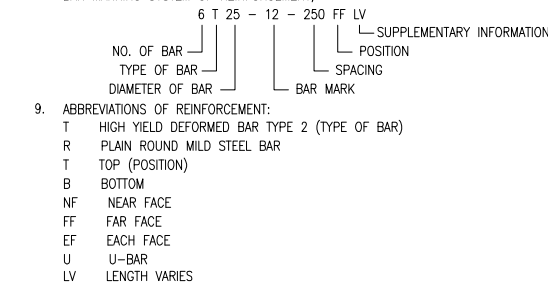

NOTES ON DOUBLE CORROSION PROTECTION

- GROUT TO COMPLETELY FILL THE HOLE TO THE FINISHED SLOPE SURFACE.
- CORRUGATED SHEATH SHALL BE MADE FROM HIGH DENSITY THERMOPLASTIC MATERIAL AND THE WALL THICKNESS SHALL BE AT LEAST 1mm.
- MINIMUM GROUT COVER OF 10mm FOR CORRUGATED SHEATH AND STEEL BAR SHALL BE PROVIDED.
- MINIMUM GROUT COVER OF 15mm FOR CORRUGATED SHEATH AND BOREHOLE CIRCUMFERENCE SHALL BE PROVIDED.
- PROTRUSION OF WIRE SHALL BE PROVIDED IF NAIL LENGTH CHECKING AFTER CASTING OF SOIL NAIL HEAD IS REQUIRED.

NOTES ON CONSTRUCTION OF SKIN WALL

- MINIMUM COVER TO REINFORCEMENT SHALL BE 50mm.
- CONCRETE FOR SKIN WALL SHALL BE GRADE 30/20 DESIGN MIX TO GENERAL SPECIFICATION FOR CIVIL ENGINEER WORKS 2006 EDITION, HONG KONG GOVERNMENT.
- STONE FACING SHALL BE PROVIDED ON THE CONCRETE SKIN WALL. THE DETAILS OF STONE FACING SHALL REFER TO CEDD STD DRG NOS. C2002/1D AND C2002/2B.

No.	Date	Description	Checked
C	05/12	GEO COMMENTS	EC
B	04/12	GEO COMMENTS	EC
A	07/11	GEO/GAU COMMENTS	EC
-	02/11	FIRST SUBMISSION	EC

Revision	Name	Date
Surveyed		
Designed	KR	05/2012
Drawn	ZXM	05/2012
Reviewer	CC	05/2012
Checked	EC	05/2012

Approved	
Project Director / Ove Arup & Partners (ALBERT HO) Hong Kong Ltd	
Date : MAY-12	

Agreement no.	CE 32/2004 (GE)
---------------	-----------------

Arup project no.	24506
------------------	-------

Contract	UPGRADING/IMPROVEMENT OF ROADSIDE SLOPES/RETAINING WALLS ON HONG KONG ISLAND (2005 TO 2008 PROGRAMME)
----------	--

Feature	11SW-B/R93 DUDDLELL STREET
---------	-------------------------------

Drawing Title	SITE LOCATION PLAN AND GENERAL NOTES
---------------	---

Drawing no.	24506/BR93/UI01	Rev	C	Scale	AS SHOWN
-------------	-----------------	-----	---	-------	----------

Consulting Engineer	ARUP Ove Arup & Partners Hong Kong Ltd
---------------------	---

Office	WORKS DIVISION
--------	----------------

Office	WORKS DIVISION
--------	----------------

Office	WORKS DIVISION
--------	----------------

DO NOT SCALE DRAWING. CHECK ALL DIMENSIONS ON SITE.
 ALL RIGHTS RESERVED.
 © OVE ARUP & PARTNERS HONG KONG LIMITED.

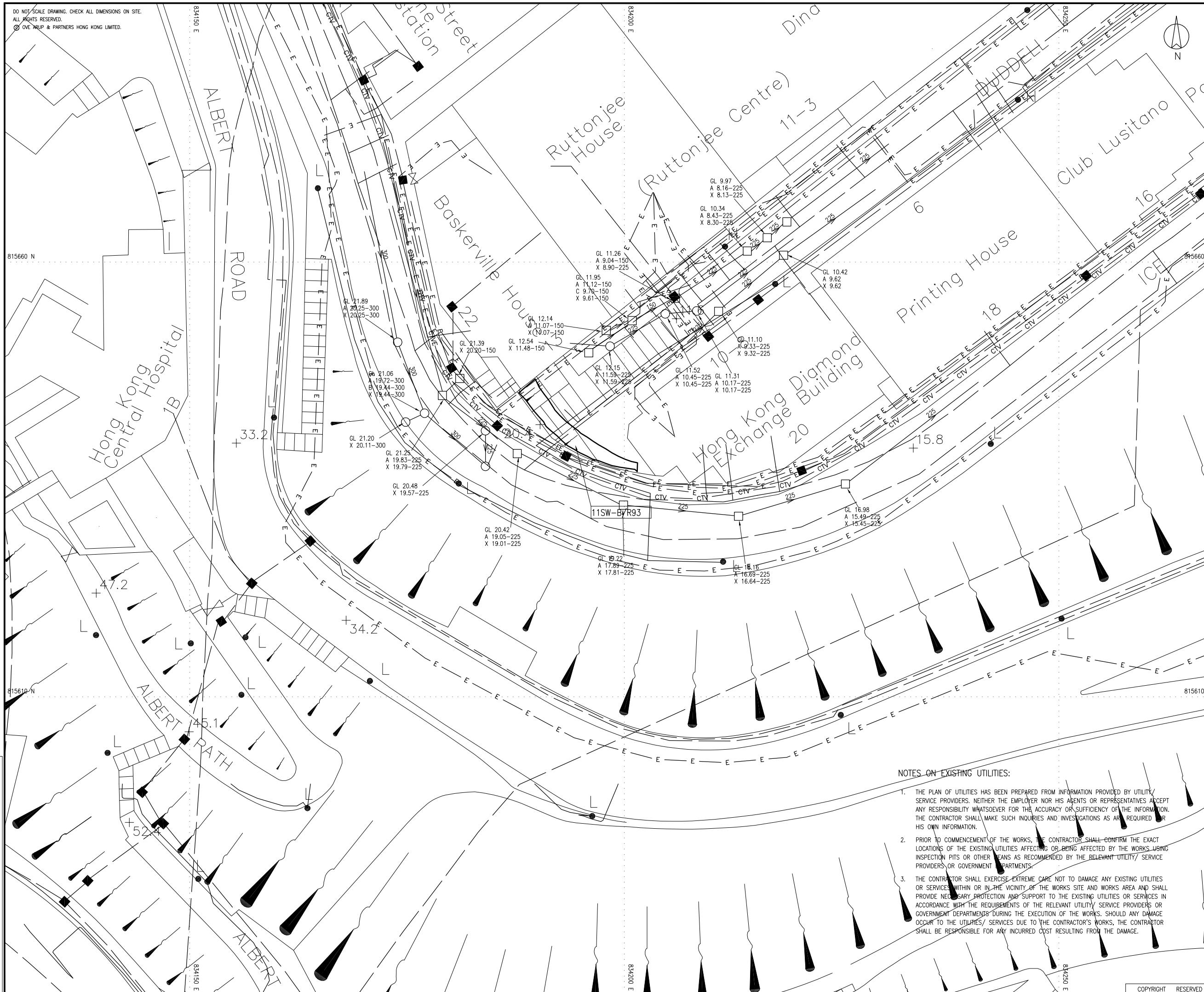

- LEGEND:**
- EXISTING FEATURE BOUNDARY
 - - - PRIVATE LOT BOUNDARY
 - WATERWORKS
 - EXISTING FRESH WATER MAINS
 - EXISTING SALT WATER MAINS
 - DRAINAGE
 - EXISTING FOUL SEWER
 - EXISTING STORM WATER DRAIN
 - TELEPHONE
 - EXISTING TELEPHONE DUCT
 - EXISTING TELEPHONE JOINT BOX
 - ELECTRICITY
 - - - E - - - PROPOSED ELECTRICITY DUCT
 - E — EXISTING ELECTRICITY DUCT
 - EXISTING STREET LIGHT DUCT
 - GAS
 - EXISTING LP/MP PIPES
 - CCTV
 - CCTV — EXISTING CCTV DUCT
 - EXISTING CCTV JOINT BOX
 - OTHER
 - HGC — EXISTING HGC PLANT

No.	Date	Description	Checked

Approved
 Project Director / Ove Arup & Partners
 (ALBERT HO)
 Date : DEC-05

Agreement no. CE 32/2004 (GE)

Arup project no. 24506

Contract
 UPGRADING/IMPROVEMENT OF
 ROADSIDE SLOPES/RETAINING WALLS
 ON HONG KONG ISLAND
 (2005 TO 2008 PROGRAMME)

Feature
 11SW-B/R93
 DUDELL STREET

Drawing Title
 PLAN OF EXISTING FEATURE
 AND UTILITIES

Drawing no.	Rev	Scale
24506/BR93/UI/02	-	1:200

Consulting Engineer
ARUP Ove Arup & Partners
 Hong Kong Ltd

Office
 WORKS DIVISION



- NOTES ON EXISTING UTILITIES:**
1. THE PLAN OF UTILITIES HAS BEEN PREPARED FROM INFORMATION PROVIDED BY UTILITY / SERVICE PROVIDERS. NEITHER THE EMPLOYER NOR HIS AGENTS OR REPRESENTATIVES ACCEPT ANY RESPONSIBILITY WHATSOEVER FOR THE ACCURACY OR SUFFICIENCY OF THE INFORMATION. THE CONTRACTOR SHALL MAKE SUCH INQUIRIES AND INVESTIGATIONS AS ARE REQUIRED FOR HIS OWN INFORMATION.
 2. PRIOR TO COMMENCEMENT OF THE WORKS, THE CONTRACTOR SHALL CONFIRM THE EXACT LOCATIONS OF THE EXISTING UTILITIES AFFECTING OR BEING AFFECTED BY THE WORKS USING INSPECTION PITS OR OTHER MEANS AS RECOMMENDED BY THE RELEVANT UTILITY/ SERVICE PROVIDERS OR GOVERNMENT DEPARTMENTS.
 3. THE CONTRACTOR SHALL EXERCISE EXTREME CARE NOT TO DAMAGE ANY EXISTING UTILITIES OR SERVICES WITHIN OR IN THE VICINITY OF THE WORKS SITE AND WORKS AREA AND SHALL PROVIDE NECESSARY PROTECTION AND SUPPORT TO THE EXISTING UTILITIES OR SERVICES IN ACCORDANCE WITH THE REQUIREMENTS OF THE RELEVANT UTILITY/ SERVICE PROVIDERS OR GOVERNMENT DEPARTMENTS DURING THE EXECUTION OF THE WORKS. SHOULD ANY DAMAGE OCCUR TO THE UTILITIES/ SERVICES DUE TO THE CONTRACTOR'S WORKS, THE CONTRACTOR SHALL BE RESPONSIBLE FOR ANY INCURRED COST RESULTING FROM THE DAMAGE.

DO NOT SCALE DRAWING. CHECK ALL DIMENSIONS ON SITE.
 ALL RIGHTS RESERVED.
 © OVE ARUP & PARTNERS HONG KONG LIMITED.

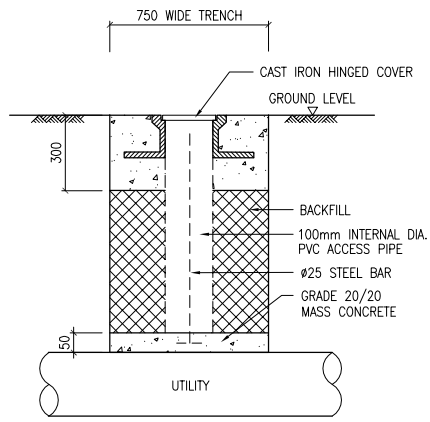

TYPICAL DETAILS OF UTILITY SETTLEMENT MONITORING POINT
 N.T.S.

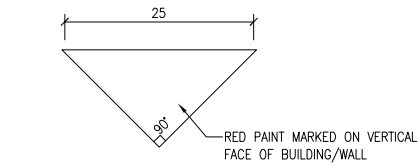

BUILDING SETTLEMENT POINT
 N.T.S.

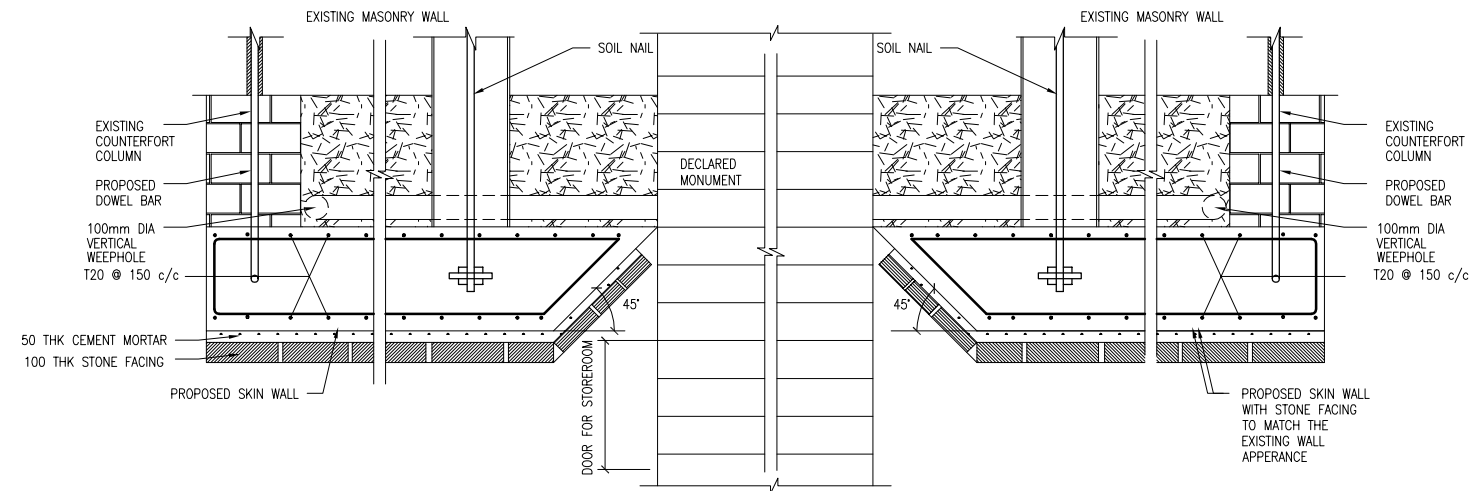

ADDITIONAL PLAN OF SKIN WALL
 N.T.S.

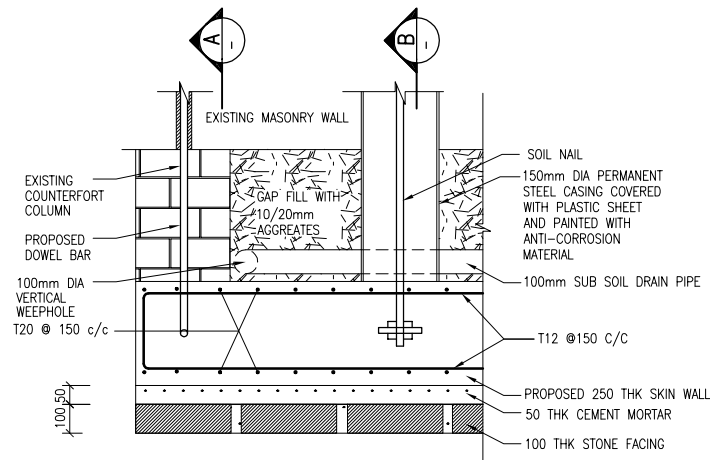

TYPICAL DETAILS OF SKIN WALL
 N.T.S.

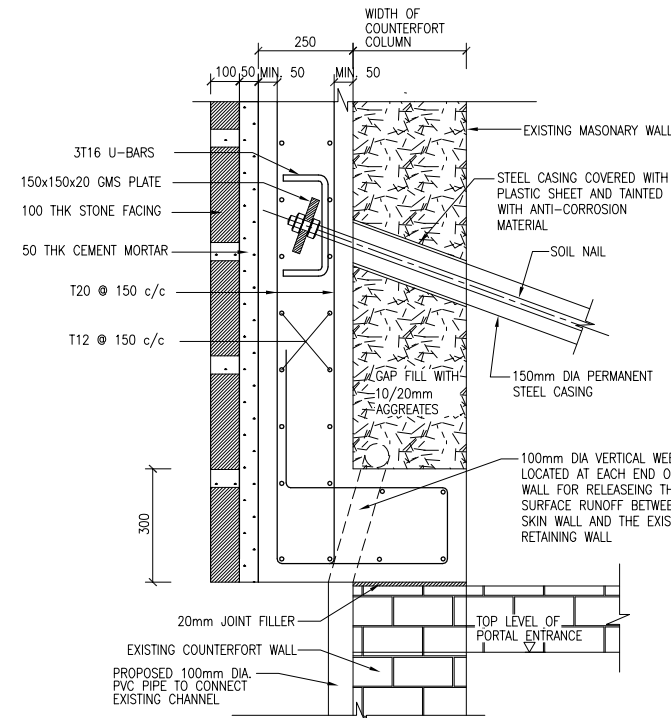

SECTION B
 N.T.S.

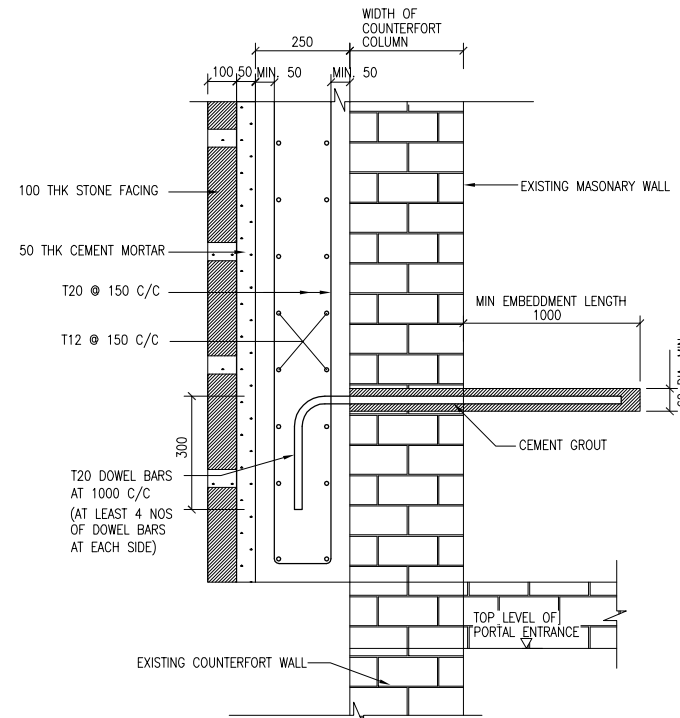

SECTION A
 N.T.S.

LEGEND:

No.	Date	Description	Checked
D	05/13	AMO COMMENTS	EC
C	12/12	PLAN ADDED	EC
B	09/12	VERTICAL WEEPHOLE ADDED	EC
A	04/12	GEO COMMENTS	EC
-	07/11	GEO/GAU COMMENTS	EC

Revision	Name	Date
Surveyed		
Designed	KR	09/2012
Drawn	ZXM	09/2012
Reviewer	CC	09/2012
Checked	EC	09/2012

Approved
 Project Director / Ove Arup & Partners
 (ALBERT HO) Hong Kong Ltd
 Date : MAY-13

Agreement no. CE 32/2004 (GE)

Arup project no. 24506

Contract
 UPGRADING/IMPROVEMENT OF
 ROADSIDE SLOPES/RETAINING WALLS
 ON HONG KONG ISLAND
 (2005 TO 2008 PROGRAMME)

Feature
 11SW-B/R93
 DUDELL STREET

Drawing Title
 TYPICAL DETAILS

Drawing no. 24506/BR93/UI04

Rev D Scale 1:200

Consulting Engineer

ARUP Ove Arup & Partners
 Hong Kong Ltd

Office
 WORKS DIVISION

路政署
HIGHWAYS DEPARTMENT