

EARLY CHINESE PHOTOGRAPHERS FROM 1840 TO 1870: INNOVATION AND  
ADAPTATION IN THE DEVELOPMENT OF CHINESE PHOTOGRAPHY

By

SHI CHEN

A THESIS PRESENTED TO THE GRADUATE SCHOOL  
OF THE UNIVERSITY OF FLORIDA IN PARTIAL FULFILLMENT  
OF THE REQUIREMENTS FOR THE DEGREE OF  
MASTER OF ARTS

UNIVERSITY OF FLORIDA

2009

© 2009 Shi Chen

## ACKNOWLEDGMENTS

First and foremost, I would like to thank my parents for their unconditional love and support. I would like to thank my committee chair, Dr. Guolong Lai for his incredibly insightful and patient guidance from the conception to the very gradual completion of what began as a seemingly endless thesis project. I would also like to thank my committee member, Dr. Glenn Willumson for his great interest and support from the selection of my thesis project to the end product. I would like to thank Ms. Dixie Neilson and Dr. Amy Vigilante for the warmth they gave me over the past three years. Additionally, I owe my countless thanks to the following individuals, without whom this project would not have been possible: Dr. Frances Terpak, Beth Guynn, John Kiffe, and Teresa Mesquit at the Getty Research Institute; Dr. Raymond Lum at the Harvard East Asian Yanching Library; Dr. Phillip Prodger at the Peabody Essex Museum; and Claartje van Dijk at the International Center of Photography. Finally, I want to thank my friends, especially Zhenning Zhang, Lingling Xiang, Litao Lu, Zhen Liu, Ruth Sheng, Yue Zhang, Ruixin Jiang, Elizabeth Coker, Claudia Cervantes, Chole Smith, Sarah Mullersman, Oaklianna Brown and Dushanthi Jayawardena for helping me maintain both my sanity and sense of humor over the course of the last three years. Last but not the least, I also must thank (and apologize too) whose name has been forgotten here.

## TABLE OF CONTENTS

	<u>page</u>
ACKNOWLEDGMENTS .....	3
LIST OF FIGURES .....	5
ABSTRACT .....	6
CHAPTER	
1 INTRODUCTION: THE EARLY DEVELOPMENT OF CHINESE PHOTOGRAPHY .....	8
2 THE ADVENT OF PHOTOGRAPHY IN CHINA IN THE 1840S AND 1850S .....	10
Photography in China Introduced from the West .....	10
Photography Experiments by Chinese Practitioners.....	13
Luo Yili 羅以禮 (1802-1852) .....	13
Zou Boqi 鄒伯奇 (1819-1869).....	15
The Influences of Early Chinese Photographers on the Later Development.....	22
3 LAI AFONG AND CHINESE PHOTOGRAPHY IN THE 1860S AND 1870S .....	24
Photography in China from the 1850s to the End of the 19th Century .....	24
Lai Afong and His Photographic Studio.....	25
4 CONCLUSION: THE ROLE OF CHINESE PHOTOGRAPHERS IN THE EARLY HISTORY OF PHOTOGRAPHY IN CHINA .....	40
LIST OF REFERENCES .....	46
BIOGRAPHICAL SKETCH .....	52

## LIST OF FIGURES

<u>Figure</u>	<u>page</u>
2-1 Self-portrait of Luo Yili, c.1850, Chinese Photographers' Association .....	14
2-2 Sketch of <i>Sheying Qi</i> (Apparatus of Capturing Images) based on Zou Boqi's description (Li 1977, 311).....	18
2-3 Self-portrait of Zou Boqi, c.1860s, China Photography Museum .....	20
3-1 Portrait and autograph of Lai Afong, c.1870. The Scottish National Portrait Gallery, Edinburgh.....	25
3-2 Afong's advertisement in <i>The Daily Advertiser</i> (Hong Kong, Oct.2, 1871) .....	29
3-3 Joss House, Hong Kong, Attributed to Lai Afong, c.1860s, Phillips Library .....	30
3-4 Commercial Street, Guangzhou, Lai Afong, c.1860s, Phillips Library .....	32
3-5 Physic Street, Guangzhou, John Thomson, c.1860s, Cambridge University Library .....	33
3-6 Treasury Street, Guangzhou, Felice Beato, April 1860. Santa Barbara Museum of Art (Harris 1999).....	33
3-7 The Barber and Client, Lai Afong, c.1860s, the Getty Research Institute. ....	34
3-8 Itinerant barbers, John Thomson, c. 1868-1872, collection of Clark Worswick .....	35
3-9 Itinerant barber, Paul Champion, 1865-1866, the Metropolitan Museum of Art .....	36
3-10 The "Grand Stand" Foochow, Lai Afong, date unknown, the Metropolitan Museum of art.....	38

Abstract of Thesis Presented to the Graduate School  
of the University of Florida in Partial Fulfillment of the  
Requirements for the Degree of Master of Arts

EARLY CHINESE PHOTOGRAPHERS FROM 1840 TO 1870:  
INNOVATION AND ADAPTATION  
IN THE DEVELOPMENT OF CHINESE PHOTOGRAPHY

By

Shi Chen

August 2009

Chair: Guolong Lai  
Major: Museology

It is widely assumed in scholarly literature that photography was introduced into China in the 19<sup>th</sup> century, but our current understanding of how, when, and why photography was introduced is still hazy. In this study I will analyze the early development of Chinese photography by examining three primary Chinese photographers from the 1840s to 1870s: Luo Yili (1802-1852), Zou Boqi (1819-1869), and Lai Afong (1839-c.1890), whose personal trajectories delineated the early history of Chinese photography.

Luo Yili and Zou Boqi were the earliest photographers in China in the 1840s and 1850s. Their self-made camera, photographs and scientific writings demonstrate how photography is not a purely western-introduced technology. However, they didn't have the chance to disseminate it due to their technical limitation, social immobility and common prejudice against photography. Since the 1860s, Lai Afong emerged when western-introduced photography in China had overcome initial technical difficulties and became popular in the western community. As the most significant Chinese photographer, Lai Afong left us abundant works of art. Afong's selection of subject matter and artistic style paralleled his western contemporaries, which,

combined with his great marketing skills, lead to his success, and it composes an important part of Chinese photography in the 1860s and 1870s.

In the last chapter, I explore the early history of Chinese photography and the influences of those Chinese photographers. The first Chinese manual of photography published in 1873 was embedded with the assumption that photography was a purely western invention and stated the common Chinese prejudice against it. In popular media in the 1870s such as the leading Shanghai newspaper *Shenbao* 申報, the introductory articles on photography and Chinese photographic studios' advertisements imply the same assumption. Photography was still largely perceived as a western technology by the 1870s, and the knowledge and demand of photography by Chinese people was still limited. Therefore, it is not surprising that Lai Afong gained his success mainly in western community residing in China or traveled to China. However, on the other hand, Lai Afong also earned a place for Chinese photographers in the early stage of photography in China.

## CHAPTER 1 INTRODUCTION: THE EARLY DEVELOPMENT OF CHINESE PHOTOGRAPHY

The birth of photography has a long period of pregnancy, if we see the announcement of the invention of daguerreotype in Paris in 1839 as its birth. From a purely technical point of view, photography is the fruit of a long process that had originated much earlier than its birth. There are two primary components in the development of photography, capturing images (camera) and fixing images (chemistry). The camera was understood long before photography was discovered, served as a drawing apparatus since the 16<sup>th</sup> century. The chemical aspect of photography had been studied since the 18<sup>th</sup> century. By 1837, the French man Louis-Jacques-Mandé Daguerre was able to fix images on a silver-covered copper plate, allowing images to be reproduced mechanically without any manual intervention. (Bajac 2002)

Over the next half century, photography in the west developed rapidly, “progressing from a cottage industry to a semi-industrialized business, with the phenomenal growth of portrait studios marking the medium’s popular success.” (Bajac 2002, 162) With new methods of printing and distribution, photographic images became multiplied and were soon spread around the world. The basic outlines of photography’s practical uses and social meanings also emerged with its popularization. (Marien 2002) Photography became a medium for artistic practice and documentation such as topographical surveys, scientific investigations, and reporting.

While our current understanding of early photography development has been European-centered, what was happening in China is still hazy. As the earliest photographs in China were mostly left by westerners who traveled to China, it is widely assumed that photography was introduced from the west. Until the 1870s, the history of photography in China was largely a narrative of photographic operations by European photographers who settled on the China coast. (Worswick 2008)



On the other hand, traces of early Chinese photographers – as elusive as they might have been – make us wonder about the other side of the story. Early Chinese photographers have been underrepresented, as their works of art are rare in today’s photo-collecting world. Therefore, relatively little is known about the early history of Chinese photography, yet a series of questions can be raised: What was their contribution, if at all, to the development of Chinese photography? Is photography a completely western-introduced technology? If not, how did it start in China and what was its relationship with western photography? How did early Chinese photographers develop this new technology? How did those Chinese photographers compare to their western counterparts in terms of their photographic and commercial skills?

To answer those questions, in this paper I intend to investigate three early important Chinese photographers to reconstruct their personal trajectories, and to evaluate their contributions to the early development of Chinese photography. By examining their photographic works, writings, and other relevant documents, such as news reports and advertisements, I hope to shed light on those above mentioned questions.

CHAPTER 2  
THE ADVENT OF PHOTOGRAPHY IN CHINA IN THE 1840S AND 1850S

**Photography in China Introduced from the West**

Scattered evidence suggests the advent of photography in China introduced from the west during the 1840s and 1850s. It could either have been brought to China by westerners, as the case of French Daguerreotypist Jules Itier and subsequent western photographers; or it could have been adopted by Chinese people who were exposed to photography while traveling abroad, as the case of Lin Zhen 林箴 (1824-?) and Luo Sen 羅森 (dates not known).

What is commonly viewed as the earliest recorded introduction of photography in China appeared in Qing government's diplomatic activities<sup>1</sup>. Jules Itier (1802-77), a French custom inspector, was sent in 1844 as a member of the delegation to negotiate a commercial treaty between France and China, known as the Treaty of Whampoa (Oct.24, 1844). In China, Itier took some 37 daguerreotypes of Chinese people and scenery in Aomen and Guangzhou. He also took portraits of Qi Ying 耆英 (1790-1858), the Manchu statesman who concluded the Treaty of Huangpu. He recorded those daguerreotypes in his published *Journal d'un voyage en Chine* en 1843, 1844, 1845 et 1848. (Cody and Terpak 2009, 2; Wu 2006, 26) Throughout his journal Itier recorded the astonishment of many Chinese when they saw their portraits taken with a daguerreotype camera. These photos are now held by the Musee Francais de la Photographie in Paris. Itier's daguerreotypes are the earliest preserved photographs of China. (Chen, Hu, Ma, Qian, & Peng 1990; Bennett 2008)

---

<sup>1</sup> In terms of the earliest recorded reference to photography in China, Cody and Terpak (2009), Wu (2006), Chen et al (1990) all agreed on the case of Jules Itier. However, Terry Bennett (2008) cited the *Journal* of Harry Parkes on July 16<sup>th</sup>, 1842, which recorded photograph taken on the banks of Yangzi River, upon which the British Expeditionary Force was making its way in order to obtain a treaty at Nanjing. Even if the daguerreotypes were successful, no trace of them appears in the British foreign office archives. This will need to be verified.

Other than traveling photographers such as Jules Itier, there were commercial photographers who emerged shortly after the appearance of photography in China. The first evidence was the commercial daguerreotype activities advertised by short-lived studios in the middle 1840s in Hong Kong. In the Hong Kong local English-language newspaper, the *China Mail*, a foreigner referred himself as Mr. West opened a daguerreotype studio in Sydenham Terrace near the Queen's road on March 13th, 1845. The advertisement of this photographic service stated the business was mainly for portrait photograph, and the studio opened from 10am to 4pm each day. However, Mr. West was no longer active after April 10, 1845 as no advertisement on the newspaper was found after that. (Lai 2001; Bennett 2008)

In the following year, other advertisements of photographic services continued to show up: On October 8, 1846, an advertisement appeared in the *China Mail*, stating "Daguerreotype and Lithographic printing establishment, Wellington Terrace. Colored or outline views made of Hong Kong or China Scenery... Daguerreotype Room open from 9am to 3pm." (Worswick 2008) Since the advertisement was in English, it was probably targeting western audience. Two months later, another advertisement appeared in the *China Mail*, announcing that one man named Hugh Mckay had taken over both the daguerreotype and printing (lithographic) establishments. For the following two years of 1847 and 1848, Mckay, a native of Edinburg became the first known commercial photographer of the China coast. In 1849 he disappeared from China. (Lai 1997; Worswick 2008; Bennett 2008)

During March and April of 1852, a photographer Herman Husband advertised in *The Friend of China and Hong Kong Gazette*, another English-language newspaper published in Hong Kong. (Lai 1997) Other than Mr. Husband, between 1848 and 1858, there is scattered

evidence indicating that there were a limited number of photographers working briefly in Hong Kong in the 1850s, among whom none of them were Chinese.

On the other side, during 1840s and 1850s, Chinese people who traveled abroad recorded and learned photography. Their traces were left in primarily Chinese traveling literatures. Lin Zhen 林箴 (1824-?), who was a native of Xiamen 廈門, was invited to the United States in 1847 for lecturing. He showed interest in photography and learned it. (Chen et al 1990) In his writing *Xihai jiyou cao* 西海紀游草 (Notes of Traveling to the West), he wrote,

Images of mountains, rivers and people can be captured once we point them toward the mirror (the magic mirror with chemicals can borrow sunlight to light on flowers, birds and people, and capture images within a moment. I have learned how to do it) 山川人物，鏡中指日留形（有神鏡，煉葯能借日光以照花鳥人物，頃刻留模，余詳其法）<sup>2</sup>.

As one of the earliest accounts of camera by Chinese people, “Shenjing” 神鏡 was used to refer to it. Literally translated as “magic mirror,” it shows the astonishment of Lin Zhen when he discovered this technology.

Luo Sen 羅森, a native of Guangzhou, was an assistant to American photographer Eliphalet Brown Jr., who was accompanying Commodore Perry on the historic American mission to Japan in 1853-54. Before they took the journey to Japan they stopped at the coastal area in China, probably Aomen and Hong Kong. In Hong Kong Mr. Brown took Luo Sen as his assistant. (Chen et al 1990) Luo Sen wrote journals of his travel upon his return and published them in Chinese journal *Xiaer guanzhen* 遐迹貫珍 (Chinese Serial) in Hong Kong in May 1854.

---

<sup>2</sup> It was written in 1849. The quote captured here was taken from a reprinted book in 1985. See the book’s detail in List of References.

He recorded that the camera was one of the gifts that the Americans offered to Japanese and what the camera was like:

The camera points to the sun and forms the image. We don't need any pen, and the image is permanent 日影像以鏡向日繪照成像，毋庸筆描，歷久不變<sup>3</sup>.

Another word, “riyingxiang 日影像” (sun shade image) was used to refer to the camera, which indicates the principle/process of the equipment. Although Luo Sen was the assistant to the American photographer, in his writing there is no evidence showing that he was capable of operating camera by his own.

Other than the trace of their recordings, neither Lin Zhen nor Luo Sen left us actual evidence of their photographs or photographic equipments. As the earliest reference to camera by Chinese people, it reveals their understanding of photography. “Shenjing” indicates the mystery of photography to Lin Zhen, and “riyingxiang” implies how Luo Sen understood the elements of camera and the importance of light in taking photographs. However, either “Shenjing” or “Riyingxiang” were not seen again in later literatures.

### **Photography Experiments by Chinese Practitioners**

In villages of Guangdong province in China, there is evidence of the advent of photography, which didn't follow western introduction but seemed to have created on its own.

#### **Luo Yili 羅以禮 (1802-1852)**

Luo was born in Xinhui 新會 County of Guangdong Province, about 90 miles south of Guangzhou, the capital city of Guangdong. Although not much has been discovered about him, what captures our attention is the photographic self-portrait that he made, which, based on his

---

<sup>3</sup> It was written in 1857. The quote captured here was taken from a reprinted book in 1983. See the book's detail in List of References.

life date which ends in 1852, must have been one of the earliest surviving photograph by Chinese photographers.



Figure 2-1. Self-portrait of Luo Yili, c.1850, Chinese Photographers' Association

This photo was collected and housed by the Chinese Photographers' Association. (Chen et al 1990) The poor visibility might be either a reflection of the quality itself as it was produced, or a result of its deterioration over 150 years. In this photo Luo folds his right leg and places it on the chair. He sits with his right hand on the right ankle, seemingly grasping it or just wrapping his fingers around it. It seems that he might have bare arms, which is quite unique and never found in other portraits. The end table, tea bowl and vase of flowers in the right side of the picture are consistent with portrait style of Chinese people in later period.

The early date of his photographic self-portrait is very noticeable. It was speculated that he used the ambrotype process to take this photograph. (Chen et al 1990) Since the ambrotype was not invented in the west until 1851, just one year before he died, it is almost impossible for Luo to have learned it from the west. Therefore, he could have created it on his own. (Baldwin 1991)

Another portrait photograph of “a Cantonese old woman” was also collected and housed by the Chinese Photographers’ Association, which remains to be explored. (Chen et al 1990)

### **Zou Boqi 鄒伯奇 (1819-1869)**

Zou Boqi was born in Nanhai 南海 County of Guangdong Province, about 30 miles west of Guangzhou. He left behind him not only a self-portrait and camera equipments, but also essays that demonstrate his theoretical bases, making him by far the most distinguished Chinese practitioner of photography in the 1850s, as Oliver Moore commented, “a cardinal figure in the earliest Chinese history of photography.”(2008, 34)

During the 1840s and 1850s, Zou completed two important essays on the practice of photography: *Sheying Zhiqiji* 攝影之器記 (Notes on a Mechanism for Capturing Images) and *Gushu bu* 格朮補 (Science Updates). Notes on a Mechanism is an account of the optical principles of photography. In this essay, what he describes as “Sheying zhiqi” 攝影之器 (the apparatus of capturing the image) is a camera obscura, an ancestor of the modern camera. He begins by describing the “enclosed chamber” 密室:

There is a dark chamber with a small hole in its front wall. If given the light, then all the objects outside the chamber are reflected reversely on the back wall of the chamber. The ones in the east are seen in the west, and those below are reflected above. If we install the semi-flat lens in the hole, and place a white sheet [on the back wall], then we get lively images. The distance between the sheet and the lens depends on the thickness of the lens. For example, if the sheet gets burned when the distance is one Chi<sup>4</sup> when the lens faces the sun, then the sheet will be the brightest just less than one Chi; the further, the darker. If we draw an image [from the scene being reflected], it will be as good as if we were looking at the scene upfront. If we make some changes, we use a wooden dark chamber, put the white sheet or white glass in the back, and punch a hole in the front and put the lens in it; we can

---

<sup>4</sup> Chi 尺 is a traditional unit of length measurement in China, 1 Chi = 34.5cm.

move the lens back and forth, and we open a hole in the back to look into it. We call it the Apparatus of capturing the image 有一密室，惟前壁開小孔，透光，則室外諸物盡倒影于后壁，居東者見於西，在下者射於上。以似乎非平之中高鏡安其孔，接淨白紙，則形形色色畢肖焉。紙距鏡視鏡高為遠近，如以鏡照日遠一尺得火，則紙距鏡不過一尺為最明，稍遠則漸暗也。若描寫為畫，與當面景色無少異。變而更之，以木為箱，中張白紙或白色玻璃，前面開孔安筒，筒口安鏡而進退之，後面開窺孔。隨意轉移而觀之，名曰攝影之器。(1873)<sup>5</sup>

He then explains how the heights/length/width of objects and distances between elements are proportionate and how it can be used to calculate the size of actual objects without having to measure those head to toe. Following its use in surveying, he introduces using this device to convert a view from three dimensions to two dimensions, thus facilitating the drawing of it, and he points out how several two-dimensional drawings can be put together to reconstruct a three-dimensional scene. He also mentions that it can be used to measure the degree and angle of the movement of the moon and stars at night. The above content composes the first part of this essay.

In the second part, he refers to several classic Chinese literatures, which record the phenomenon of images showing through a hole in a dark room. Those literatures include

- *Mengxi Bitan* 夢溪筆談 (Brush Talks from a Dream Brook), by scientist and statesman Shen Kuo 沈括 (1031-1095) by 1088 during the Song Dynasty.
- *Laoxuean Biji* 老學庵筆記 (Notes in Old Study Room), by poet Lu You 陸游 (1125-1210) in the Song Dynasty.
- *Chuo Geng Lu* 輟耕錄 (Notes after Quitting Farming), by historian and litterateur Tao Zongyi 陶宗儀 (1321-1407) at the end of the Yuan Dynasty.

---

<sup>5</sup> The essay was written during 1840s and 1850s, but was published in 1873.



Zou states that the purpose is to show those writings didn't make things up and he is proud to prove it. He then records that in the year of 1844 he suddenly figured out how the “Sheying zhiqi” (the apparatus of capturing images) works and extended its use to surveying and measuring.

In the third and last part of this essay, he reiterates in detailed steps as to how this device can be made and applied to uses above. The following is the translation of the last part:

I tried to use the method of drawing maps to make the apparatus of capturing images. We use a wooden chamber, drill a hole in the front and put the lens in there, put a piece of white clean paper in the chamber and the door is in the back. We put what we want to draw in front of the chamber, use black cloth to cover the back, and open the door to watch it, and we can see the object clearly on the paper, quite accurate in its shape and color. If we use color brush pen to draw, then we get a landscape painting. If we move to another place and paint another picture, and compare those two for the differences ([smaller print in the original] calculate by the distances between those objects and the center of the lens), and we can get the distances of those objects. We can also draw images, which are all originated from this use. The use [of apparatus of capturing images] is infinite, which is wonderful 畫地圖之法，余嘗製為攝影之器，以木為方箱，前面開孔，置中高鏡，中張一淨白薄紙，後面為門。將此器前面向所欲繪之處，以黑布遮後面，開門視之，則此地諸物悉見紙上，形色位置不失毫釐。以彩筆摹之則為平遠山水一幅，又移別為復摹一幅，以二幅各較其差角（[原文小字]以所繪各地距鏡心遠近高下求之），即得各地之遠近。可以畫為平面圖，矣變而通之，其用不窮，亦快事也(published in 1873).

In this essay, Zou is perhaps the first Chinese to use the expression “sheying” 攝影 (capturing images), which has been commonly adopted later to refer to photography in Chinese for all kinds of photography- plate, film, and digital. (Moore 2008) Its original meaning, as we can see from the essay, doesn't really refer to what we mean by “photography” today, which includes both capturing and fixing images.

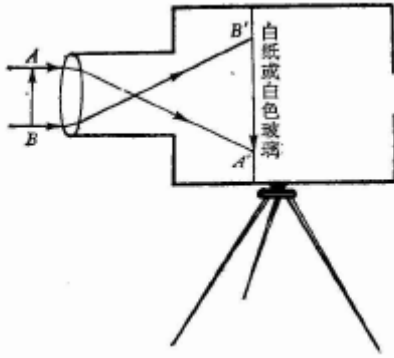

Figure 2-2. Sketch of *Sheying Qi* (Apparatus of Capturing Images) based on Zou Boqi's description (Li 1977, 311)

The other of his essays, *Science Updates* summarizes ancient Chinese principles of optics. It reviews the considerable Chinese literature on lenses, and explains methods for constructing telescopes and microscopes. It also sets out the theoretical principles for constructing camera lenses such as formulas relating to operating lenses.

As is commonly known, there are two technological bases to create a photographic image: the reception of the image using the box camera (or plate camera) and the chemical process to fix the image on a medium. Zou's essays are a perfect proof of the first half. The box camera's logical antecedent was the camera obscura, the same device Zou studied and demonstrated in the essay. Although it is generally assumed that this was a purely European device that had entertained its users, guided scientific and artistic observation, and helped to conceptualize ways of seeing in Europe since the Renaissance, both essays which involve previous writings in Chinese history and Zou's own practice proved that it possesses a Chinese history as well. (Moore 2008)

The Chinese classic *Mengxi Bitan* 夢溪筆談 (Brush Talks from a Dream Brook) was referred to as origins of his thoughts on optics in both of his essays. In *Notes on a Mechanism*, Zou writes in 1835 he observed the reflection of images and read *Mengxi Bitan* and kept thinking

about it, and then he tested it in a dark room and understood the principle of Camera obscura. In the preface of *Science Updates* by Chen Li (1810-1882), a reputed Cantonese scholar specialized in a wide range of classic studies such as phonology and ancient science, *Mengxi Bitan* was referenced again to introduce “Yangsui” 陽燧 and how it relates to Zou’s discovery. The concept of “Yangsui”, meaning concave brass mirror placed in the sun to generate enough heat to ignite dry grass, was probably related to camera obscura because they both alter the direction of light and focalize. Both Zou and Chen were predominant pioneers in natural science in the 19<sup>th</sup> century of China, and they tend to relate western-introduced modern science to ancient Chinese knowledge. (Wu 2000)

However, the second half, the fixing of images on a supporting medium was not touched upon in those two essays, nor does it seem that it occurred to Zou to apply the use of the device for capturing a permanent image when he wrote those essays. The contribution of the Apparatus of Sheying, as Zou realized at that time, lies in surveying, drawing, and astronomy, which is consistent with Zou’s scientific interest and achievement at that time. Some scholars contended that the year of 1844 and the writing of *Sheying Zhi Qiji* marks the creation of the first camera in China (Ding 2001; Chen 1993); without the proof of fixing the image, it is hard to draw that conclusion.

As the best proof of whether Zou developed the chemical side of photography as well, his self-portrait was retrieved by investigators of Chinese Photographers’ Association as a glass plate from his property in 1962. The glass plate negative is currently housed in Guangzhou City Museum and was reprinted in the 1960s and 1970s. (Dai 2000)



Figure 2-3. Self-portrait of Zou Boqi, c.1860s, China Photography Museum

Not only was his self-portrait left behind. In 1962, what was also recovered at his property was photographic implements. (Chen et al 1990) Among these were a wooden can containing rectangular wooden plate, and a funnel made of bones, all of which might have been used for evaporating mercury and developing the image. Those devices are now nowhere to be found. (Li and Bai 1984)

Also found were wooden tripod and four broken glass plates. Other than his self-portrait, there are three more, which are said to be group portraits of him and his students or fellow countrymen. (Li and Bai 1984) Unfortunately, they were nowhere to be found today. Liang Hengxin, who was a professor in Guangzhou, once saw those photographs and described one of them as another self-portrait of Zou Boqi:

The backdrop is the stone steps of an ancestral temple, and Zou sits on a stool, wearing white long gown, and handholding white round fan. Since the edge of the plate is uneven, and the backdrop is different from one of any usual photographic studio, he probably took

them himself by asking someone else to press the camera shutter (as cited in Li and Bai 1984).

Liang Hengxin, as previously mentioned who had seen the glass plates of Zou, collected unpublished essays written by Zou Boqi from his descendants and published *Zou Boqi Sheying Shiliao Chutan* 鄒伯奇攝影史料初探 (Preliminary Studies on the Historical Documents of Zou Boqi's Photography) in 1963 through the Guangzhou Division of Chinese Photography Association. The essay revealed original writings by Zou Boqi that help to reconstruct his photographic process. Unfortunately, in 2000 Dai already found it untraceable, neither is the case when we look for it today.

In 1977, Li Di wrote about Zou's study on optics, and he also cited Zou's writings from Liang's article. Those available segments of Zou's writing records steps of taking photographs, including setting up the camera and using chemicals in each step. (Li 1977) It was already greatly advanced from his earlier writing (*Notes on a Mechanism* and *Science Updates*) to purposely aim at producing a photographic image.

On a separate page of his manuscripts Zou talked about chemicals and how to make them. Zou recorded multiple chemicals that were used to take photographs, although he didn't write down the specific quantities for each of them, and he was not quite specific on what functions some of them performed. (Li 1977; Dai 2000) Zou used Latin names for a number of chemicals, which indicates that he might have known them from the west. (Li and Bai 1984) On the other side, he also used locally produced chemicals to complement the western chemicals, and even pointed out where to get these locally. (Li 1977; Li and Bai 1984) From the procedure and chemicals, those scholars speculated that the process he used was wet collodion process. (Li 1977; Dai 2000)

Zou's geographical proximity to Guangzhou, one of the earliest areas in China to have contact with the west, might have lent him opportunities to be exposed to new thoughts and technologies from the west, even remotely. As shown in his earlier writings, Zou's initial attempt to understand and create the optical devices of camera was probably aroused due to his interest in astronomy and surveying, however, once he got inspired by western photography he might have related it to the camera obscura he already created and tried to make modifications that can be applied to photography, and also researched on chemicals that can fix the image. Without the full knowledge and required equipment, he made modifications and supplemented by using indigenous ingredients. Based on a poem found by the side of his self-portrait, he should be in his late forties at the time the self-portrait was made, therefore his self-portrait might have been created in the year of 1863-1866. (Li and Bai 1984) If the year 1844 marked his discovery of camera obscura and rising interest in photography later on, it took him almost 20 years to complete the process to create photographic images on his own.

### **The Influences of Early Chinese Photographers on the Later Development**

The two self-portraits of Luo Yili and Zou Boqi are very scarce evidence of the existence of Chinese photographers in the first two decades of photographic history in China. Because of Zou's achievements shown in his writings, photographic portraits and equipments, Oliver Moore speaks of Zou's achievements as "overthrow the assumptions that photography was imported to China as either a fully perfected technology or an absolute ontological novelty." (2008, 48)

Unfortunately, despite the solid and successful attempts of photography, neither Luo nor Zou succeeded in passing on the knowledge at their time. Neither *Notes on a Mechanism* nor *Science Updates* was published before he passed away. Those writings were originally kept by his family and later organized by other scholars. The final publication was made possible by the sponsorship of Zou's students, families and friends. *Notes on a Mechanism* was published in

1873, and *Science Updates* in 1874. When they finally got published, almost 30 years after he made the camera obscura, there had already been significant development of the technology in terms of new photographic processes and better equipments, which made his discoveries much less remarkable.

There are several reasons why Luo and Zou never had the chance to lead photography's development in China. The technical limits might have been one reason, as the ambrotype they used created a single, unique image on the plate, and was not suited to mass-production of images for dissemination. On the other hand, in spite of the amazement many Chinese people had when they firstly learned about photography, there were also misunderstandings such as spiritual disrespect attached to this new medium.

The initial Chinese people's fear and suspicion toward photography lasted until the camera and the photographs it made became more familiar for them. It is not hard to imagine how many obstacles Luo Yili and Zou Boqi would have encountered if they had tried to publicize this new technology.

CHAPTER 3  
LAI AFONG AND CHINESE PHOTOGRAPHY IN THE 1860S AND 1870S

**Photography in China from the 1850s to the End of the 19th Century**

World wide, the 1850s marked the beginning of photography's commercialization. Continuing technical improvements enabled the instant capture of likenesses, as the wet plate process was invented and widely adopted, which superseded previous processes like the daguerreotype and made possible the duplication of images. Significant commercial activity became economically viable, allowing the photographer to produce multiple copies of views and portraits and make a living by selling them.

For China, political changes also facilitated the development of photography. A clause in the postwar treaty, the 1860 Peking Convention, newly granted foreign visitors the right to reside in inland cities beyond the treaty ports and to travel freely in all parts of China. The opening of China and the war itself provided an attraction to western photographers to come to China. To begin with, most of them were visiting photographers; by the 1860s, they were commercial photographers who resided in China and operated their photographic business. Those photographers brought to China a newly advanced method of visual representation when the technology itself is ready to spread. At that time in spite of the efforts that practitioners like Zou and Luo made, photography remained largely unknown to the overall Chinese community. Their gradual familiarization with the photographic process was a result of western photographers' practice in China, which also led some local Chinese to try their hands on the camera.

In the 1860s Chinese photographic studios started to establish their businesses and expand. During the 1860s one studio was already well-known and productive, which left us interesting materials to look into for this one of the first Chinese commercial photographers.



### Lai Afong and His Photographic Studio

Lai Afong 赖華芳 (1839-c.1890), active 1859-c.1890, is the most famous and successful Chinese photographer in the 19<sup>th</sup> century and proprietor of the longest-lived photographic studio in Hong Kong. Afong opened his first studio in Hong Kong in 1859, and it continued long after his death, successfully outlasting all native and European competitors to operate well up to the start of World War II<sup>1</sup>.



Figure 3-1. Portrait and autograph of Lai Afong, c.1870. The Scottish National Portrait Gallery, Edinburgh

---

<sup>1</sup> See Worswick 1978: the firm of Lai Afong was carried on by his son Yuet Chan (died, March 5, 1937), but was still listed in the 1941 *Chronicle and Directory for China, Japan (etc.)*. It was therefore, by far the longest lived commercial firm in China.

Figure 3-1 is the only known self-portrait of Afong. He signed his name in both Chinese characters as “Huafang” 華芳 and neat English script as “Afong.” “Huafang”, as signed there, is his first name in Chinese; while “Afong” is how he was widely known in the foreign community of Hong Kong. The *Guangzhou Daily* reported that the Hong Kong Department of Leisure and Cultural Services collected two of his photographs, also signed “Huafang.” (2008) It is interesting to note that even now numerous Chinese writings refer to him as “Afong” 阿芳, which is different from his actual Chinese name and is only a literal translation of “Afong”.

While many dealers and collectors have referred to him as Lai Afong or Afong Lai, or “Ah Fong” “Lai Ah Fong” occasionally, in his business such as newspaper advertisements and photo signatures, the name of “Afong” is the only one used. (Crow 2004) It might be understood as the name of his business, also how he was widely known at his time<sup>2</sup>.

Among all the middle-late 19<sup>th</sup> century Chinese photographers, Afong is the best known and has been mostly studied. The purpose of our discussion is not just to synopsise the results of other studies, but rather through the study of Afong, to try to understand how photography developed in China through Chinese photographers.

Afong is one of the few exceptions of Chinese photographers in his time. Other Chinese photographers’ works have mostly vanished, leaving them only known by name from contemporary commercial directories. However, large numbers of Afong’s photographs survive today, probably as a result of both his productivity and audience’s recognition for his works of art. They have been widely housed in museums worldwide. They were either purchased by westerners in China and brought back to the west, or later collected by contemporary western

---

<sup>2</sup> For consistence, Lai Afong will be referred to as “Afong” in following discussion.

collectors from various sources. Institutions that house Afong's work are listed below but not limited to:

Album:

- *Views of Foochow*, Scottish National Portrait Gallery, Edinburgh, Scotland (Wue 1997)
- *Hong Kong and Macao: the Typhoon of 22 September 1874*, Foreign and Commonwealth Office Library, London, UK (Marien 2002)
- *Hong Kong View of City and Port*, the Peabody Essex Museum, Salem, MA (site visit)
- *Typhoon of September 22<sup>nd</sup>-23<sup>rd</sup> – 1874*, the Peabody Essex Museum, Salem, MA (site visit)

Loose prints:

(The numbers of those loose prints are unknown until further exploration of those sites is conducted.)

- The J Paul. Getty Research Institute, Los Angeles, CA (online finding aids)
- National Galleries of Scotland, Edinburgh, Scotland (online)
- San Francisco Museum of Modern Art, San Francisco, CA (online)
- Special collections of the University of Glasgow, Glasgow, Scotland (online)
- National Gallery of Australia, Parkes Pl, Parkes ACT 2600, Australia (online)
- British Library, London, UK (British Library, 2008)
- Collection of Tsim Bok-Kow, Carte-de-visite, location unknown (Wue, 1997)
- St. Louis Art Museum, St. Louis, MO (Eskind, 1998)
- Peabody Essex Museum, Salem, MA (site visit)
- Metropolitan Museum of Art, New York, NY (site visit)

It is worth noting that although many photographs bear the Afong stamp, the majority of his work was unsigned and has not yet been positively identified. (Crow 2004) Even though, those collections compose by far the largest amount and most significant photographs by mid-late 19th Chinese photographers in the world.

Compared with the widely housed collections in cultural institutions or individuals overseas, Afong's works are rarely kept in China. There was an exhibit "Historical Photographs of China in British Collections 1860-1930" held in the National Library in Beijing in the fall of 2008. About 150 old photographs taken in Hong Kong and Guangzhou were firstly shown in

China, a large number of which were taken by Afong. It was the first time for many Chinese people to have the opportunity to look at his works of art and learn about him. Even for the associate director of the National Library, before the exhibit all he knew about Afong was from a pamphlet stored in the National Library which only mentioned his name and stories. (Guangzhou Daily 2008)

Afong seemed to have gained his reputation among western people in China and it was through them that his photographs survived, were disseminated, and preserved. Compared with practitioners like Zou Boqi and Luo Yili, the story of Afong presents another thread in the development of Chinese photography, which was originated from the western context and developed in the western community. It is also a much more visible and traceable thread as a result of the commercialization of Afong's photographic practice.

During the 1860s and 1870s in Hong Kong, many Chinese photographers were initially export trade painters working in the field of export painting in southern China who went to Hong Kong to set up their studios as the colony emerged as an international trading port in the Far East. (Lai 1997) With the rise of photographic market in Hong Kong, photography became another possible avenue for the production of tourist products. Those export trade painters might have entered photography in a variety of ways: they could have apprenticed with a foreign photographer as assistants, to have learned it abroad or possibly through local schools set up by missionaries for Chinese students, where photography and other Western technical skills were taught. Afong might have learned photography through one of the above ways. However, unlike many Chinese photographers, who used the medium to augment their painting income, Afong probably did camera-work full time. In Figure 3-2 Afong's advertisement, he only identified

himself as “photographer,” whereas other Chinese photographers often advertised themselves as “photographer and painter.” (Marien 2002)

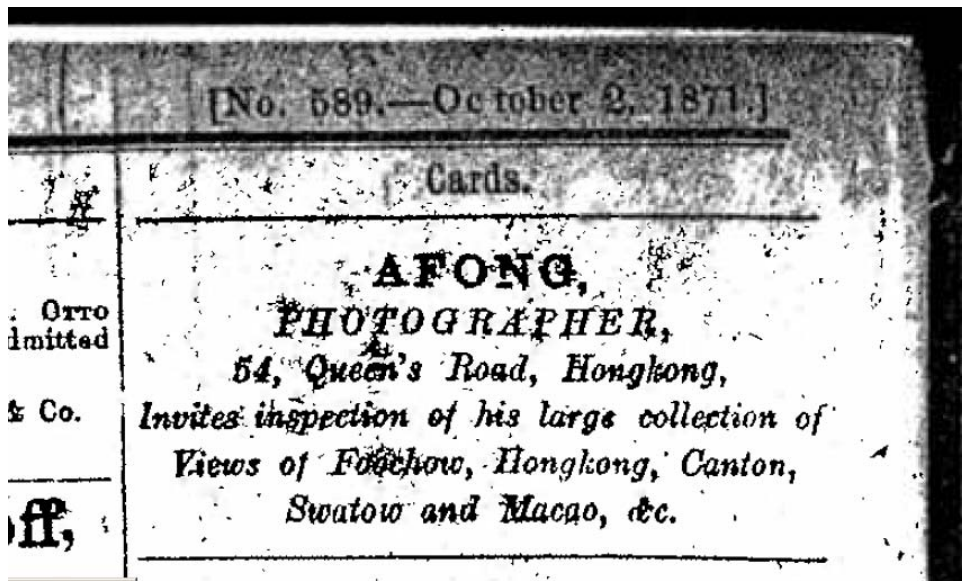

Figure 3-2. Afong’s advertisement in *The Daily Advertiser* (Hong Kong, Oct.2, 1871)

Afong advertised his up-to-date achievement of photography. Figure 3-2 is an example of him marketing his photo albums of Foochow, HongKong, Canton, Swatow and Macao<sup>3</sup>. Afong traveled around the coastal area of the country to take photographs. He took an extensive series of pictures in the area of Foochow in 1869 and 1870. (National Galleries of Scotland, 2008) He traveled far north as Weihaiwei in Shandong Peninsula in north China. (Wue 1997) The subject matter of his photographs includes architecture (both European and indigenous), town views in and around the treaty ports, social life, and important historical events such as the cyclone which devastated Hong Kong in 1874<sup>4</sup>.

While portraiture had dominated Chinese use of photography as other subjects had little interest for Chinese photographers and their clientele in the 1860s and later period (Wue 2008),

<sup>3</sup> Nowadays cities named Fuzhou, Hong Kong, Guangzhou, Shantou, and Aomen.

<sup>4</sup> View photographs of this event in National Library of China, British Library, 2008. *Western Eyes: Historical Photographs of China in British Collections: 1860-1930*. Beijing: Guojia Tushu Chubanshe.

Afong's photographic interest extended well beyond that. His choice of subjects other than portraiture include topographical views as shown above, and scenes of social life as shown below, two genres typically created for the Western market in China and abroad.

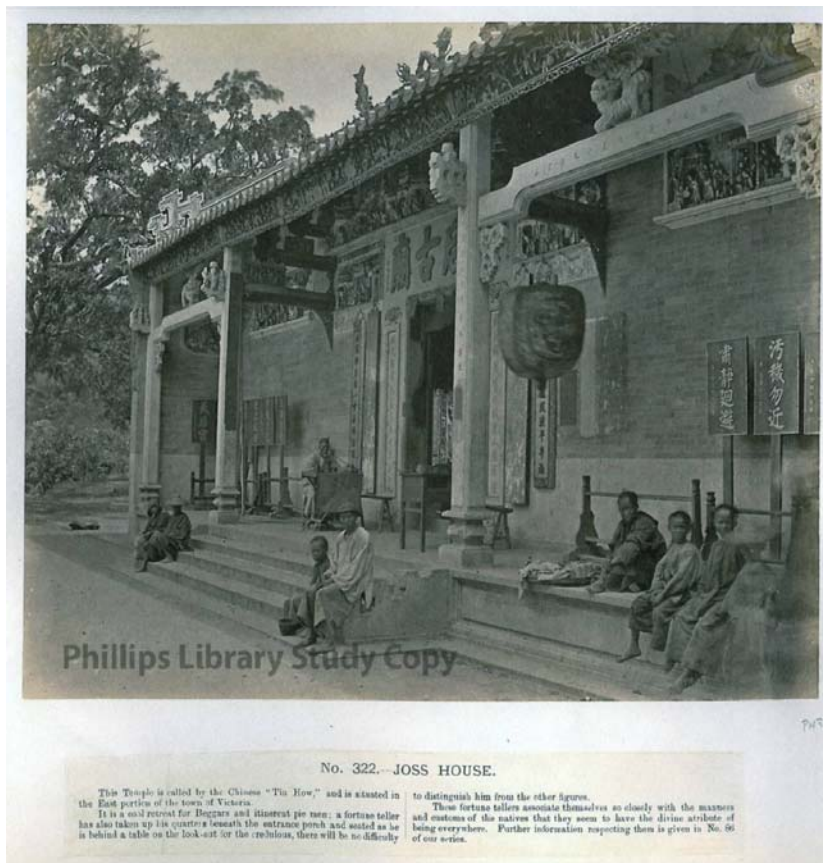

Figure 3-3. Joss House, Hong Kong, Attributed to Lai Afong, c.1860s, Phillips Library

Figure 3-3 is one of Afong's photographs housed in Phillips Library at the Peabody Essex Museum. Other than the choice of subject matter, Afong demonstrates his skills in composing and presenting chosen subjects. There are many elements in this photo that can be elaborated in their Chinese context: the temple with very distinctive architectural style (called "Tianhou" 天后 (or "Tin How" in Cantonese) in the caption below the photo), its function and meaning for Chinese people; the Chinese characters on boards leaning against the temple wall and their

meanings; the fortune teller sitting behind the table on the entrance porch, and several groups of other people staring at the camera, evoking viewers' curiosity about who they are and what they are doing.

This photo was numbered. Along with other individual prints with the same format in the Peabody Essex Museum, it probably belongs to a series of photographs demonstrating the essence of China in the 19<sup>th</sup> century. The caption below the image reads:

No. 322 – JOSS HOUSE

This Temple is called by the Chinese 'Tin How,' and is situated in the East portion of the town of Victoria.

It is a cool retreat for Beggars and itinerant pie men; a fortune teller has also taken up his quarters beneath the entrance porch and seated as he is behind a table on the look-out for the credulous, there will be no difficulty to distinguish him from the other figures.

These fortune tellers associate themselves so closely with the manners and customs of the natives that they seem to have the divine attribute of being everywhere. Further information respecting them is given in No.86 of our series.

The caption elaborates those Chinese elements in a way that extends beyond the image itself and touches upon Chinese culture behind it. It seems to have been written by someone who knew well of Chinese social life, as he/she knew how the temple was called in Cantonese, and seemed to be quite knowledgeable about fortune tellers, a repeated theme in other photos of the series. It was not clear who wrote the caption, but Afong, with an insight of the Chinese culture and western interest, probably contributed to the caption in one way or another. He might have put together the photo series of China and worked with someone else to write those captions.



Figure 3-4. Commercial Street, Guangzhou, Lai Afong, c.1860s, Phillips Library

Another photo of this series presents a more common subject in Chinese social life as street views. Predominant western photographers in Afong's time such as John Thomson and Felice Beato took photographs of the same kind, as shown in Figure 3-5 and 3-6.





Figure 3-5. Physic Street, Guangzhou, John Thomson, c.1860s, Cambridge University Library



Figure 3-6. Treasury Street, Guangzhou, Felice Beato, April 1860. Santa Barbara Museum of Art (Harris 1999)

In the above three photos of Guangzhou street scenes, narrow streets with intensive and concentrated shop signs are featured, showing what a bustling business district looks like in China. Those street signs make the street look even narrower, creating an overwhelming sense to grasp one's attention.

The caption of Afong's photo reads:

No.259 – A STREET, CANTON [Guangzhou]

The streets in all native cities (except Peking, the Northern Capital) are identical in their narrowness and gloom; wanting to the eye of a foreigner the day appearance universal in the cities of Europe, their tortuous windings, however, possess the advantage of cutting off the blazing rays of hot sunshine, and a stroll through would doubtless be enjoyable were it not for the variety of indescribable smells that rouse the olfactory nerves to antagonism with the will of an explorer.

Curio shops abound in these narrow labyrinths, but the prices asked for the wares are generally very exorbitant, and the business in consequence is not expensive.

The caption of Afong's street scene seems to be perfectly applicable to other two photos, which shows how similar their subject matter and approach was in taking those photos.



Figure 3-7. The Barber and Client, Lai Afong, c.1860s, the Getty Research Institute.



Figure 3-8. Itinerant barbers, John Thomson, c. 1868-1872, collection of Clark Worswick

The photographs of “trades and types” possess both a curiosity and a liveliness which present to the viewer a veritable opera of China, and were one of the major subjects for the market. (Worswick 2008) Figure 3-7 and 3-8 were taken respectively by Afong and John Thomson, with almost the same setup and perspective: the client is sitting on the left on a bench with almost the same wood-carving pattern, and the barber is standing and shaving his forehead. The client is holding probably a plate to catch the falling hair. Also similar is the tool kit of the barber on the right with broad-brimmed straw hats. The backdrops of both photos are minimized, and it was probably done on purpose by staging the scene in the studio, in order to make the barber, client, and their apparatus stand out.

Figure 3-9, however, provides another approach to take photographs of the same subject matter. The photographer, Paul Champion was a French amateur photographer, who visited China in 1865-1866, almost the same time period when Afong and John Thomson’s photos were taken. Champion put together a fine portfolio of Shanghai and Beijing.



Figure 3-9. Itinerant barber, Paul Champion, 1865-1866, the Metropolitan Museum of Art

Showing also “itinerant barber”, Champion’s photo shows a different setup: it was taken outside in a real street scene, therefore the lighting is natural, and the background has more elements such as walls and houses. Because the barber and client take a smaller portion of the picture compared with Afong or Thomson’s photo, Champion might have taken the photo from a longer distance, trying to be less interrupting as he was probably taking photographs of the real scene. Consequently, we can’t see the barber’s hands very clearly, and details of his operation and equipment are less shown. The client is not holding anything to catch the falling hair, which was probably the case when the haircutting took place in the street, and make them look more casual and real. Comparing with both Thomson and Champion’s photo, there is a clear tendency of Afong who chose Thomson’s approach to take photos, probably for commercial and professional purposes.

The consistency of Afong’s work with its counterparts by professional western photographers is not just a result of his technological and artistic competence, but also his awareness of achieving them by learning from foreign colleagues. John Thomson, the most well-

known western photographer of that period, operated his studio in the same district (on Queen's Road) in Hong Kong as Afong, and they seemed to maintain a good relationship with each other.

Afong's work must have been of sufficient standard to earn the attention and praise of John Thomson, as Thomson remarked in 1872,

There is one China-man in Hong Kong, of the name of Afong, who has exquisite taste, and produces work that would enable him to make a living even in London... Retracing our steps up Queen's Road we pause beneath a display of signboards, each one glowing in bold Roman characters... the first we come to is that Afong, photographer Afong keeps a Portuguese assistant to wait upon Europeans... [Afong is] a man of cultivated taste, and imbued with a wonderful appreciation of art. Judging from the portfolios of photographs, he must be an ardent admirer of the beautiful in nature, for some of his pictures, besides being extremely well executed, are remarkable for their artistic choice of position...

The comment that Afong can make a living even in London shows how much Afong is acknowledged by Thomson. Afong's "exquisite", or "cultivated" taste, is probably the result of the combination of his choice of subject matter and the style of his photos, which is indistinguishable from his professional western contemporaries and certainly meets their standards.

In addition to Afong's photographic talent, Afong's excellent business skills also lead up to his success. Afong aimed at the western market in China to promote his business. As John Thomson mentioned, Afong hired a Portuguese assistant to do business with the Europeans, so that he could develop sales with the European community. Other than the Portuguese assistant, there were at least two more foreign photographers who worked for Afong at that time, Emil Rusfeldt and D.K. Griffith. Rusfeldt was in Afong's Studio from October 1871 to around March 1872. He then opened his own establishment, the Hong Kong Photographic Rooms in April 1872. Griffith started his service with Afong in July 1878, and he opened his own photographic studio in May 1884. (Lai 2001) Afong was so involved in the community of western

photographers that not only was he on good terms with some of them, his studio also became a base to hire and train western photographers.



Figure 3-10. The “Grand Stand” Foochow, Lai Afong, date unknown, the Metropolitan Museum of art

As a Chinese photographer, Afong was trusted by foreigners to take photographs for them. Figure 3-10 shows an example. Afong signed his name in the lower left corner of the photo. The occasion of the assembly is unknown. There were around 40 foreigners in this photo and only a few Chinese people. It is somewhat hard to imagine how one Chinese photographer standing behind the camera and coordinating all these foreigners to take this group photo.

Afong’s prestige was increased by photographing H.E. Sir Arthur Kennedy, Governor of Hong Kong and H.I.H., the Grand Duke Alexis of Russia, as he was prompt to mention in his advertising. (Crow 2004; Bennett 2008)

Afong's full dedication to photography, active marketing strategies, good relationship with western photographers and clients, and aesthetic quality which contains both Chinese elements and western tastes all contributed to his success. In the mean time, he showed us how in the 1860s and 1870s the practice of Chinese photography directly followed the expansion of Western interests. Not only did Afong learn the technology from the westerners, he made his living and gained reputation through foreigners including foreign residents in Hong Kong, traveling businessmen, tourists, and viewers in Europe and America.

CHAPTER 4  
CONCLUSION: THE ROLE OF CHINESE PHOTOGRAPHERS IN THE EARLY HISTORY  
OF PHOTOGRAPHY IN CHINA

As Terry Bennett remarked, “it is worth making the point that, in reality, relatively little is yet known about the history of Chinese photography, and the work of the key western and Chinese photographers has yet to be properly researched and chronicled” (295), it is not easy to trace Chinese photographers in the early development of Chinese photography. Photographic evidence has to be combined with documents such as personal writings, news reports and advertisements to reveal even a slice of their history. Because of the difficulty of piecing together evidence, Chinese photographers were underrepresented for a long time. Capa argued in 1972, it is the western travelers who went to China and brought photography there that made the sole contribution to it, as he states

Photography and travel have been associated since the earliest moments of the medium in the 1840s. It is only by keeping this fact in mind that words about China and the history of photography make any sense at all, for the Chinese produced no pioneers in the medium nor did they contribute to the advancement of its technology (78).

As materials were gradually revealed, more recent studies by scholars like Clark Worswick, John Falconer, Nick Pearce, and Terry Bennett acknowledge Chinese photographers, particularly after the 1870s when they outnumbered Western photographers and took over this branch of work by the end of the 19th century.

However, prior to this period when photography was still in its embryonic stage for Chinese photographers, not much has been revealed about how they emerged from scratch to thriving. During this period, most Chinese photographers were only known by name as their works of art have been missing. For their extant photographs, they are considered to have followed European styles of work, and a distinctively Chinese style only emerged in the early twentieth century. (Falconer 2002)



By looking at the achievement of the earliest Chinese practitioners such as Zou Boqi and Luo Yili, it is not exaggerating to suggest that photography is not a purely foreign-invented technology, and that China possesses the creation of photography of its own. Zou Boqi's essays not only record part, if not all, of his camera invention, but also relate his discovery to the historical development of the study of optics in ancient China with intrinsic historical insight. His chemical process, if verified, replaced some of the western ingredients by local substances, which demonstrates the uniqueness of his creation. Their two self-portraits prove the early existence of photography by Chinese practitioners.

Nevertheless, their influence on early Chinese photography was limited. When Zou's essay finally got published in 1873, western photography with new photographic processes and better equipments had already penetrated into China, and Chinese photographers such as Afong learned this technology from an already commercialized and popularized market.

The difficulties of passing along the knowledge partly lie in the common misunderstanding of photography among Chinese society. Even in the later years after western photography has entered China, we still find accounts as below by the Shanghai commercial photographers D.K. Griffiths (who later worked for Afong in 1878-1884) in the London-based *Photographic News* in 1875:

The native artist has little support from his countrymen, and for the cause none are to be found away from the foreign settlements [Hong Kong and Shanghai]. Some few enterprising Cantonese have tried to push business in a few of the large towns in the interior, but were obliged to withdraw, from the hostility of the natives...in the case of a china-man he would have fared much worse [writer's italics]... This unfortunate hostility to photographic manipulation is due to a strange belief... the photographic image is the soul of the original, the withdrawal of which from the body very naturally produces death. This tragic end may not take place for a month or more, but I have heard two years given as the longest time a photographic victim can exhibit (as cited in Worswick 2008).

As a matter of fact, because their findings were so limitedly spread, up until 1870s, photography was still commonly viewed as a purely western-introduced technology. The preface of *Geshu Bu* was written by Chen Li 陳澧 (1810-1882)<sup>1</sup>. He particularly pointed out that

Thanks to this book [*Geshu bu*], what once was lost by ancient scientists [the use of lenses] was again revealed to the world. On the other side, we now know that the principle of making lenses by westerners was actually possessed by our ancient scientists. It is a wonderful science book of today 有此書而古算家失傳之法，復明於世，又可知西洋制器之法，實古算家所有，此今世算家之奇書也。(1874)

Chen argued against the commonly accepted concept that “the principle of making lenses,” as one of the important components to photography, was brought to China by westerners. Moreover, as will be shown below, there was more to just the optic aspect that were considered to be invented by the west.

In 1873, the first Chinese manual focusing exclusively and well-roundly on photography, *Tuoying Qiguan* 脫影奇觀 (Extraordinary Sights of Photography) was completed by a British Doctor residing in Beijing, Dr. John Dudgeon<sup>2</sup>. It was published in the same year in traditional Chinese book format using woodblocks for both text and illustrations and bound in soft paper covers. Wanyan Chonghou 完顏崇厚, an official at the Office of Foreign Affairs, wrote the preface and pointed out that the book “reveals the secrets [of photography] that have lasted decades.” Wanyan Chonghou represented the group of well educated Chinese people in higher social rank, who recognized the importance of photography and eager to help with its

---

<sup>1</sup> Chen Li (1810-1882), a well-established Cantonese scholar. He had profound knowledge and extensive learning in mathematics, astronomy, sutra study, history, music rhythm, phonology, ancient Chinese prose, and calligraphy.

<sup>2</sup> Dr. Dudgeon was a British physician who came to China in 1862 and spent nearly 40 years in China until his death in 1901.

distribution, but even people like him had no knowledge of previous existence of similar technology created by Chinese people themselves.

In Dr. Dudgeon's own introduction, he stated that one of the purposes of writing the book was to help people learn photography and to argue against people who "presumptuously defame it [photography], and assert that it is either the water of eyes or the blood of human heart." There was still the common superstitious fear toward camera even in 1870s, several decades after the medium was introduced.

Dr Dudgeon's introduction was also published in *Zhongxi Wenjian Lu* 中西聞見錄 (Peking Magazine) in 1872 (March, No.9), a monthly journal by missionaries for the purpose of disseminating modern western science and technology. It was noted in the journal that "the books are being printed and will be published soon." Along with other introduced western technology in the journal such as western medicine and mathematics, photography was clearly viewed as one of them, waiting to be distributed by western missionaries.

In 1876, *Shenbao* 申報 (the Shanghai Newspaper) published an article "Photography – introduction to the workings of the new technology." It starts with the statement that

Photography was invented by the west and was not found in China before. The portraits it takes are quite like real, showing people's expressions and only the difference as little as a hair might be caught. It is magical 照相之法，西國所創，中國所無，所照人像，神情畢肖，毫髮之差，亦一奇也。

Then it introduced basic steps of taking photographs, followed by retracing its origins in France and recent development and application in printing.

In 1876, the well known photographer Liang Shitai 梁時泰 (a.k.a See Tay) advertised his studio in *Shenbao* 申報 (Shanghai Newspaper) by announcing that he "learned photography

from the westerners secretly.” Advertising for its exclusiveness by declaring its western origin might serve as a selling point, and the word “secretly” emphasizes the exclusiveness of the technology. It also facilitated the common view that photography was introduced by the west. As Oliver Moore points out, “advertisement readers – none of whom had heard of Zou Boqi – were eagerly convinced that photographic practice was Western, and early advertisement strengthened this prejudice.” (2007, 6)

When Zou Boqi was working on his experiments to make photographic images on his own around 1860, Afong started his business in Hong Kong. As the only one of its kind that distinguished himself as a well-established Chinese photographer, Afong left us not only rich collections of his work, but also the story of how photography was disseminated as a new medium by Chinese people at the beginning of the popularization of Chinese photographic studios.

With the effort of Afong and those later Chinese photographers, ever since the 1860s, the narrative of photography in China shifts from the domination of pioneer Europeans to a history of commercial Chinese photographers. Chinese photographers operated studios alongside those western photographers in cities like Hong Kong, Guangzhou, Shanghai, and Beijing. In Hong Kong, the first center of photography in China, the acclaimed Scottish photographer John Thomson stated in 1872,

It may not be generally known that the Chinese in Hong-kong and other parts of China have ‘taken kindly’ to have photography... In Queen’s-road, the principal street of Victoria, there are a score of Chinese photographers, who do better work that is produced by the herd of obscura dabblers who cast discredit on the art in this country. (1872, 569)

Thomson’s statement indicated the number of Chinese photographers who had opened business in Hong Kong and started to take over photographic market, and this trend seemed to

continue. In February 1884, Baron Stillfried, an Austrian photographer, reported in London's *Photographic News*,

After the late war of England and France with China had terminated, several professional photographers settled in the celestial empire and took native assistants; but ultimately the assistants commenced on their own account, and at the present time it is probable that there are several thousand Chinese who make a living by photography.(1884)

Despite of the accuracy of Stillfried's count of Chinese photographers, he must have seen competition in every corner of the dark room to have felt this way.

The limited influence by Zou Boqi and Luo Yili suggested that the dissemination of photography in China had to rely not just on the technology itself, but ultimately on a society that was ready and in need. Because of the limited knowledge and demand for photography among Chinese, up till the 1870s the photographic market in China was mainly targeted to foreigners, and the advertisement of Chinese photographic establishments didn't appear in Chinese-language newspapers until the 1890s in Hong Kong (Lai 2001), when some wealthy Chinese went to the studios to have their portraits made. (Lam 1982)

Without the western community expanding in China after the two opium wars, there wouldn't have been such a photographic market in the western community in China. Afong sensed the opportunity and grasped it very well. It was the western clientele he relied on in the early period of his business that essentially maintained his establishments and enabled him to leave such amount of photographs. Therefore, only by maximizing the western market of photography in learning, producing and selling photographs could people like Afong earn a place in the early stage of photography in China. Their simultaneous and different paths present us two threads of the early development of Chinese photography.

## LIST OF REFERENCES

- BAJAC, QUENTIN. 2002. *The Invention of Photography*. New York: Harry N. Abrams.
- BALDWIN, GORDON. 1991. *Looking at Photographs: Guide to Technical Terms*. Los Angeles: The J. Paul Getty Museum in association with British Museum Press.
- BEERS, BURTON F. 1978. *China in Old Photographs 1860-1910*. New York: Charles Scriber's Sons.
- BENNETT, TERRY. 2008. "China." In *Encyclopedia of Nineteen-century Photography*. John Hannavy, 292-95. New York: Taylor & Francis Group.
- . 2008. "Lai Afong." In *Encyclopedia of Nineteen-century Photography*. John Hannavy, 815. New York: Taylor & Francis Group.
- BOERSCHMANN, ERNST. 1982. *Old China in Historic Photographs: 288 views*. New York: Dover Publications.
- BROWN, ELIPHALET M. JR. 2009. "Daguerreotypist and Artist for the Perry Expedition to Japan." Retrieved Jun.15, 2009, from <http://www.baxleystamps.com/litho/brown.shtml>
- CAMBRIDGE UNIVERSITY LIBRARY. 2009. "Illustrations of China and Its People." Retrieved Oct.30, 2008, from <http://www.dspace.cam.ac.uk/bitstream/1810/1186/1/RCSPC-Y30377G-XX.jpg>
- CAMERON, NIGEL. 1978. *The Face of China: as Seen by Photographers and Travelers 1860-1912*. New York: Aperture.
- CAPA, CORNELL, ed. 1972. *Behind the Great Walls of China: Photographs from 1870 to the Present*. New York: The Metropolitan Museum of Art.
- CHEN, HONGGUANG. 1993. "Zhongguo zizhi diyibu zhaoxiangji" [The first self-made camera in China]. *Lingnan wenshi* [Lingnan culture and history] 1:49.
- CHEN, SHEN, ZHICHUAN HU, YUNZENG MA, ZHANGBIAO QIAN, and YONGXIANG PENG. 1990. *Zhongguo sheying shi 1840-1937* [History of photography in China 1840-1937]. Taiwan: Photographer Publications.
- CHEN, LI. 1874. "Ge shu bu yuanxu" [Original preface of Ge shu bu]. In *Bai fu tang suan xue cong shu* [Science series of Baifu Tang]. Changsha: Gu he hua jing she.
- CODY, JEFF & FRANCES TERPAK. 2009. "Transferring the Image: the Art and Science of Photography in late Qing China." Presented in conference: Photography in China, Apr.24-25, 2009, Northwestern University.

- CROW, DENNIS GEORGE. 2004. "Afong and Other Hong Kong Photographers." In *Historic Photographs of Hong Kong – Featuring Photographs by Afong, E. O. Hoppe, Daisy Wu and Others*. Dennis George Crow, 6. Los Angeles: Dennis George Crow.
- DAI, NIANZU. 2000. "Zou Boqi de sheying ditu he boban sheyingshu" [Zou Boqi's photographic map and glass plate photographic process]. In *Zhongguo keji shiliao* [Historical materials of science and technology in China] 21(2): 25-28.
- DUDGEON, JOHN. 1873. "Yuan xu" [Original preface]. In *Tuoying qiguan* [Extraordinary sights of photography]. John Dudgeon. Beijing: Jingdu Shiyiyuan [Imperial Hospital].
- . 1873. *Tuoying Qiguan* [Extraordinary sights of photography]. Beijing: Jingdu Shiyiyuan [Imperial Hospital].
- DING, MINJING. 2001. "Sheying shu de yanjin yu zhaopian de jianding fa" [The development of photography and the methodology of photograph authentication]. *Zhongguo bowuguan* [Chinese museum], 4:58-68.
- ESKIND, ANDREW H, ed. 1998. *International Photography: George Eastman House Index to Photographers, Collections, and Exhibitions*. New York: G.K. Hall; London: Prentice Hall International.
- FALCONER, JOHN. 2002. "19<sup>th</sup> Century Photographers of China." In *Images de la Chine: Photographies 1870-1890*. John Falconer, 10-15. Paris: Les Editions Du Pacifique.
- FRANK, DIKOTTER. 2008. "The history of photography in China." Retrieved Oct.18, 2008, from <http://web.mac.com/dikotter/iWeb/Dikotter/Photography.html>
- GUANGZHOU DAILY. 2008. "Guangdong Lai Afong: zhongguo sheyingjie de bizu he jiaobao" [Lai Afong in Guangdong: the ancestor and pride of Chinese photography]. *Guangzhou Daily*, Oct.27, A3.
- HACKER, ARTHUR. 2004. *China Illustrated: Western Views of the Middle Kingdom*. Boston, Mass.: Tuttle.
- HAHN, THOMAS. 2008. "The Bibliography of Photo-albums and Materials Related to the History of Photography in China and Tibet before 1949." Retrieved October 26, 2008, from <http://gatheringmountains.net/Photoweb/>
- HARRIS, DAVID. 1999. *Of Battle and Beauty: Felice Beato's Photographs of China*. Santa Barbara, Calif.: Santa Barbara Museum of Art.
- HIRSCH, ROBERT. 1999. *Seizing the Light: A History of Photography*. Boston, Mass: Mc Graw Hill.

- HU, ZHICHUAN. 1993. *Zhongguo bainian sheying tulu 1844-1979* [A century of photographs in China 1844-1979]. Huzhou: Fujian Meishu Chubanshe.
- HU, ZHICHUAN & SHEN CHEN. 1999. *Zhongguo jiuyinglu: zhongguo zaoqi sheying zuopin xuan* [Old China photographs: selection of early Chinese photographs]. Beijing: Zhongguo Sheying Chubanshe.
- HUANG, RONGFANG & HUALING LUO. 2008. “Feisheng haiwai hongji xianggang: yidai dashi huoshi Taishan ren” [Renowned internationally and in Hong Kong: the master of the generation might come from Taishan]. *Guangzhou Daily*: Oct. 31, A3.
- HUMMEL, ARTHUR, ed. 1944. *Eminent Chinese of the Ch'ing Period [1644-1912]*. Washington, D.C.: U.S. Government Print Office.
- NATIONAL LIBRARY OF CHINA & BRITISH LIBRARY. “Introduction: Western Eyes: Photography in China 1860-1930.” 2008. In *Western eyes: historical photographs of China in British Collections, 1860-1930*. 9-11. Beijing: Guojia Tushu Chubanshe.
- LAI, AFONG. 1871. “Advertisement.” *The Daily Advertiser* No.589: Oct.2.
- LI, BOQIN & LIANJIIE ZHENG, ed. 2003. *Zhongguo chuanshi sheying* [The best photos of China]. Jilin: Jinlin Photography Publishing House.
- Li, Di. 1977. “Zou Boqi dui guangxue de yan jiu” [Zou Boqi’s studies on optics]. *Wuli* [Physics], 6 (5): 308-13.
- LAM, ROBERT P.F. 1982. “Introduction.” In *The Hong Kong Album: a Selection of the Museum’s Historical Photographs*. Hong Kong Museum of History, 2-5. Hong Kong: Urban Council.
- LAI, EDWIN. 1997. “Picturing Hong Kong: Photography through Practice and Function.” In *Picturing Hong Kong: photography 1855-1910*. Roberta Wue et al, 49-57. New York: Asia Society Galleries, in association with South China Print. Co., Hong Kong.
- . 2001. “The dawn of Hong Kong photography 1839-1919.” *Besides*, 3: 1-16.
- LI, DI & SHANGSHU BAI. 1984. “Woguo jindai kexue xianqu Zou Boqi” [Zou Boqi: the science pioneer in modern China]. *Ziran kexueshi yanjiu* [Studies on the history of natural sciences], 3(4): 378-90.
- LIANG, SHITAI. 1876. “Advertisement.” *Shebao* [Shanghai Newspaper]: May 7.
- LIN, ZHEN. 1849, reprinted in 1985. “Xihai jiyou cao” [Notes of traveling to the west]. In *Zou xiang shi jie cong shu* [Series of Knowing the World], ed. Zhong, Shuhe, 88-102. Hunan: Yuelu Shushe.



- LUO, SEN. 1857, reprinted in 1983. "Ribei riji" [Diary in Japan]. In *Zaoqi riben youji wuzhong* [Five types of travel journals in Japan in early period]. Sen Luo et al, 92-100. Changsha: Hunan Renmin Chubanshe.
- LUO, ZHENGXIAN. 1983. "Shi Zou Boqi Ge Shu Bu" [Interpreting Zou Boqi's "Science Updates"]. *Zhongguo keji shiliao* [Historical materials of science and technology in China] 2: 31-37.
- MARIEN, MARY WARNER. 2002. "Small Wars: Colonial Expansion and Photography." In *Photography: a Cultural History*. Mary Warner Marien, 118-23. London: Laurence King.
- MODERN CHINESE VISUAL ARTS BIBLIOGRAPHIES. 2008. Retrieved Oct.18, 2008, from <http://mclc.osu.edu/rc/ART.htm>
- MOORE, OLIVER. 2007. "Zou Boqi on Vision and Photography in Nineteenth Century China." In *The Human Tradition in Modern China*, ed. Kenneth J. Hammond and Kristin Stapleton, 33-53. Lanham, MD: Rowman & Littlefield.
- . 2007. "Photography in China: a Global Medium Locally Appropriated." *IIAS Newsletter*, Summer 2007: 6-7.
- PALMQUIST, PETER E, ed. 2000. *Photographers: a Sourcebook for Historical Research: Featuring Richard Rudisill's Directories of Photographers, an Annotated Bibliography*. Nevada City, Calif.: Carl Mautz Club.
- PEARCE, NICK. 2004. *Photographs of Peking, China 1861-1908: An inventory and Description of the Yetts Collection at the University of Durham*. Lewiston, New York: The Edwin Mellen Press.
- . 2007. "A Life in Peking: the Peabody Albums." *History of Photography* 31(3): 276-93.
- THE PHOTOGRAPHIC NEWS. 1884. "Photography in Eastern Asia." *The Photographic News* 28(1330): 129.
- THE SENTARO DAGUERREOTYPE – FIRST JAPANESE TO BE PHOTOGRAPHED. 2009. Retrieved Jun.15, 2009, from [http://www.old-japan.co.uk/article\\_daguerreotype.html](http://www.old-japan.co.uk/article_daguerreotype.html)
- SHENBAO. 1876. "Photography – Introduction to the Workings of the New Technology." *Shenbao* [Shanghai Newspaper] Feb.22.
- SHI, SHAOHUA.1982. "A Brief History of Photography in China." In *Sheying lilun he shijian* [Theory and practice of photography]. Shaohua Shi, 5-12. Beijing: Xinhua Chubanshe.

- SONG, GANG. 2007. “Zhongguo yishu sheying shilun – lun zhongguo yishu sheying de wuge shiqi jiuzhen langchao” [Discussion on the history of artistic photography in China – on its five periods and nine trends]. Retrieved Dec.20, 2008, from [www.CPAnet.cn](http://www.CPAnet.cn)
- THIRIEZ, REGINE.1999. “Photography and Portraiture in Nineteenth-century China.” *Eastern Asian History*, 17/18: 77-102.
- THOMSON, JOHN. 1872. “Hong Kong Photographers.” *The British Journal of Photography* 10(656): 569.
- WANYAN, CHONGHOU. 1873. “Preface.” In *Tuoying qiguan* [Treaties on photography]. John Dudgeon. Beijing: Jingdu Shiyiyuan [Imperial Hospital].
- WORSWICK, CLARK. 1978. *Imperial China: Photographs 1850-1912*. New York: Pennwick Publishing.
- . 2008. “Photography in Imperial China.” In *Sheying: Shades of China 1850-1900*. Clark Worswick, 11-17. Madrid: Turner.
- WU, GANG. 2006. “Earliest photographs in China.” In *Sheying shihua* [History of photography]. Gang Wu, 3-19. Beijing: Zhongguo Sheying Chubanshe.
- WU, JIANXIN. 2000. “Chen Li, Zou Boqi de ziran kexue guan” [Chen Li, Zou Boqi’s viewpoints on natural sciences]. *Journal of Guangdong Education Institute* 20 (4): 89-93.
- WU, SUXIN. 1984. *Zhongguo sheying shihua* [History of photography in China]. Shenyang: Liaoning Meishu Chubanshe.
- WUE, ROBERTA. 1997.” The Beginnings of Hong Kong Photography.” In *Picturing Hong Kong: photography 1855-1910*. Roberta Wue, et al, 27-48. New York: Asia Society Galleries, in association with South China Print. Co., Hong Kong.
- . 2005. “Essentially Chinese: the Chinese portrait subject in nineteenth-century photography.” In *Body and face in Chinese visual culture*. Hung Wu and Katherine R. Tsiang, 257-80. Cambridge, Mass.: Harvard University Asia Center: Distributed by Harvard University Press.
- ZHONGXI WENJIAN LU [Peking Magazine]. 1872. Peking: Peking Hospital No.9.
- ZOU, BOQI. 1873. “Sheying zhi qiji” [Notes on a mechanism for capturing images]. In *Zou zhengjun cunqao. Xuxiu siku quanshu*. Shanghai: Shanghai Guji Chubanshe.
- . 1874. “Ge shu bu” [Science updates]. In *Bai fu tang suan xue cong shu*. Changsha: Gu he hua jing she.

ZHONGGUO SHEYING BOWUGUAN JI LAOZHAOPIAN WANG [China Photography Museum & China Old photographs website]. 2008. Retrieved Oct.11, 2008, from <http://www.chinaoldphoto.com/>

ZHONGGUO SHEYING BOWUGUAN [China Photography Museum]. 2008. Retrieved Oct.11, 2008, from <http://museum.cpanet.cn/>

## BIOGRAPHICAL SKETCH

Shi Chen currently works at the Getty Research Institute as a research assistant in the Collection Development Department. She received her bachelor's degree in museum studies from Sichuan University in China. During her undergraduate she also studied at the University of Washington for one year as an exchange student. She has done internships in National Women's History Museum and the Getty Research institute.