

GPO PRICE \$ _____

CFSTI PRICE(S) \$ _____

18 Copies

Hard copy (HC) 3.00

Microfiche (MF) 165

ff 653 July 65

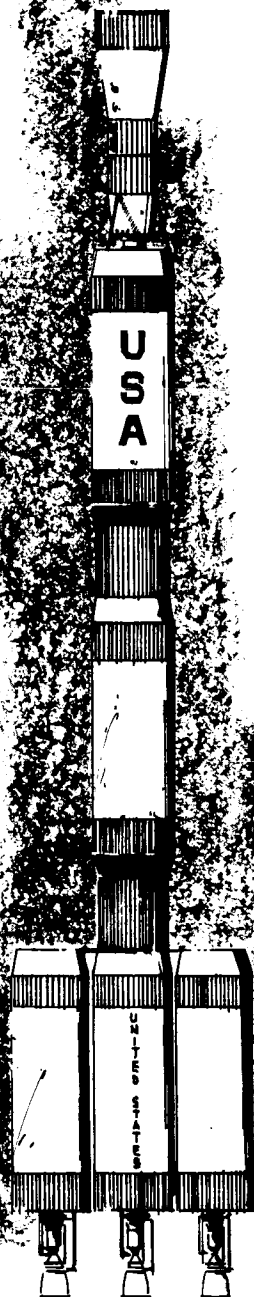

FACILITY FORM 602

N 68-19247 (THRU) _____
 (ACCESSION NUMBER)

288 (PAGES) _____
 (CODE) _____

ND-66564 (NASA CR OR TMX OR AD NUMBER) _____
 (CATEGORY) 031

INTEGRATED MANNED INTERPLANETARY SPACECRAFT CONCEPT DEFINITION

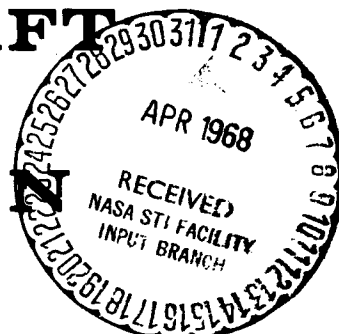

Volume VI
D2-113544-6

*Cost-Effective Subsystem Selection
and Evolutionary Development*

The BOEING Company • Aerospace Group • Space Division • Seattle, Washington

INTEGRATED MANNED INTERPLANETARY
SPACECRAFT CONCEPT DEFINITION
FINAL REPORT
VOLUME VI
COST-EFFECTIVE
SUBSYSTEM SELECTION AND
EVOLUTIONARY
DEVELOPMENT
D2-113544-6

Prepared for
NATIONAL AERONAUTICS AND SPACE ADMINISTRATION
LANGLEY RESEARCH CENTER
Hampton, Virginia

NASA CONTRACT NAS1-6774

January 1968

Distribution of this report is provided in the interest of
information exchange. Responsibility for the contents
resides in the author or organization that prepared it.

RECOMMENDED INTERPLANETARY MISSION SYSTEM

The recommended interplanetary mission system:

- Is flexible and versatile
- Can accomplish most of the available Mars and Venus missions
- Is highly tolerant to changes in environment, go-ahead dates, and funding.

It provides:

- Scientific and engineering data acquisition during all mission phases
- Analysis, evaluation, and transmission of data to Earth
- Return to Earth of Martian atmosphere and surface samples

The mission system is centered around the *space vehicle* which consists of the *space acceleration system* and the *spacecraft*.

The *space acceleration system* consists of five identical nuclear propulsion modules:

- Three in the Earth departure stage
- A single module in the planet deceleration stage
- A single module in the planet departure stage

Propellant is transferred between the stages, as necessary, to accommodate the variation in ΔV requirements for the different missions. This arrangement provides considerable discretionary payload capacity which may be used to increase the payload transported into the target planet orbit, the payload returning to the Earth, or both.

The *spacecraft* consists of:

- A biconic Earth entry module capable of entry for the most severe missions
- An Apollo-shaped Mars excursion module capable of transporting three men to the Mars surface for a 30-day exploration and returning
- A mission module which provides the living accommodations, system control, and experiment laboratories for the six-man crew
- Experiment sensors and a planet probe module

The spacecraft and its systems have been designed to accomplish the most severe mission requirements. The meteoroid shielding, expendables, system spares, and mission-peculiar experiment hardware are off-loaded for missions with less stringent requirements.

The space vehicle is placed in Earth orbit by six launches of an uprated Saturn V launch vehicle which has four 156-inch solid rocket motors attached to the first stage. Orbital assembly crew, supplies and mission crew transportation are accomplished with a six-man vehicle launched by a Saturn IB.

A new launch pad and associated facility modifications are necessary at Launch Complex 39 at Kennedy Space Center to accommodate:

- The weight and length of the uprated Saturn V
- The launch rate necessary for a reasonable Earth orbit assembly schedule
- The solid rocket motors used with the uprated Saturn V
- The requirement for hurricane protection at the launch pad.

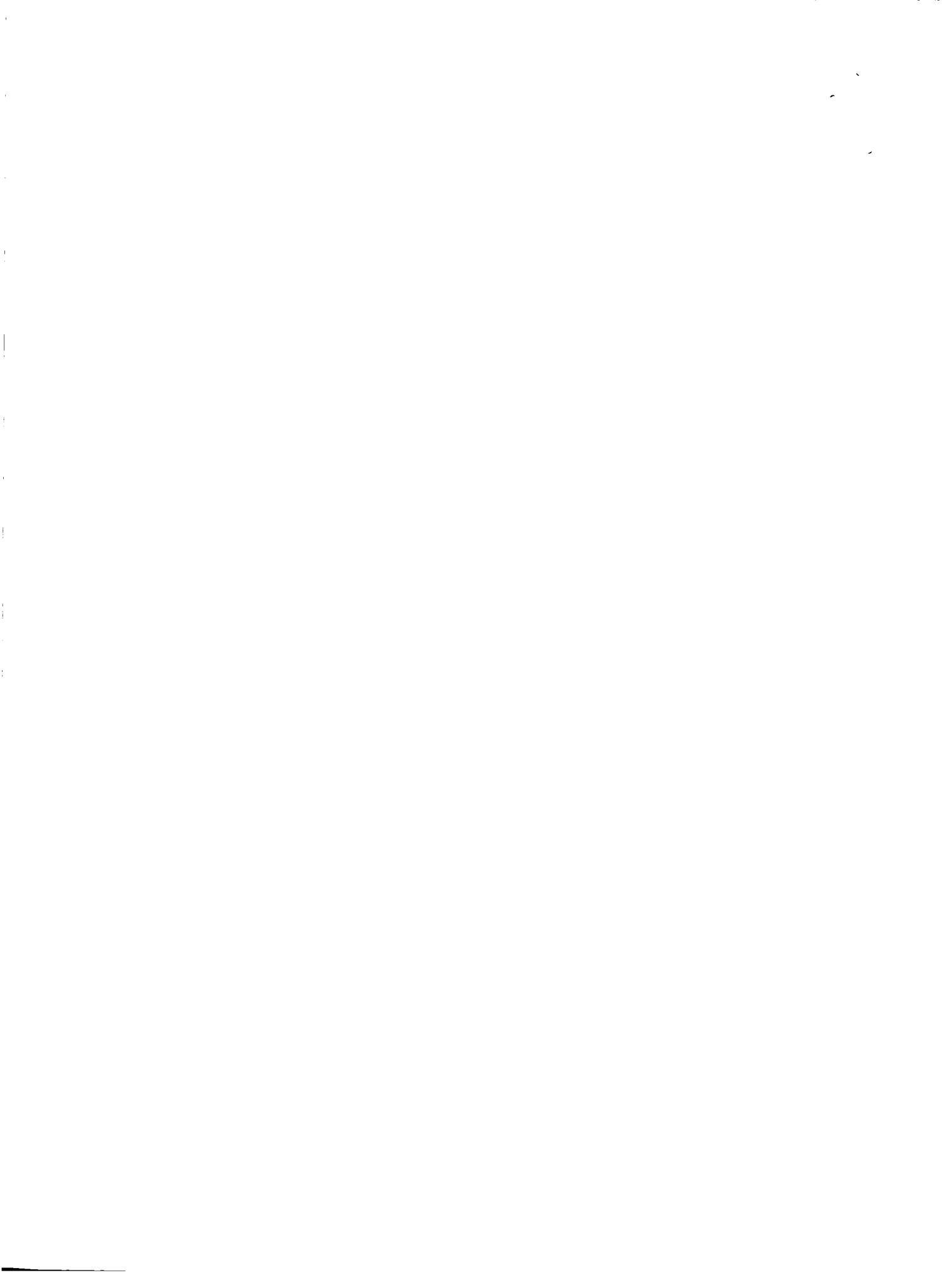

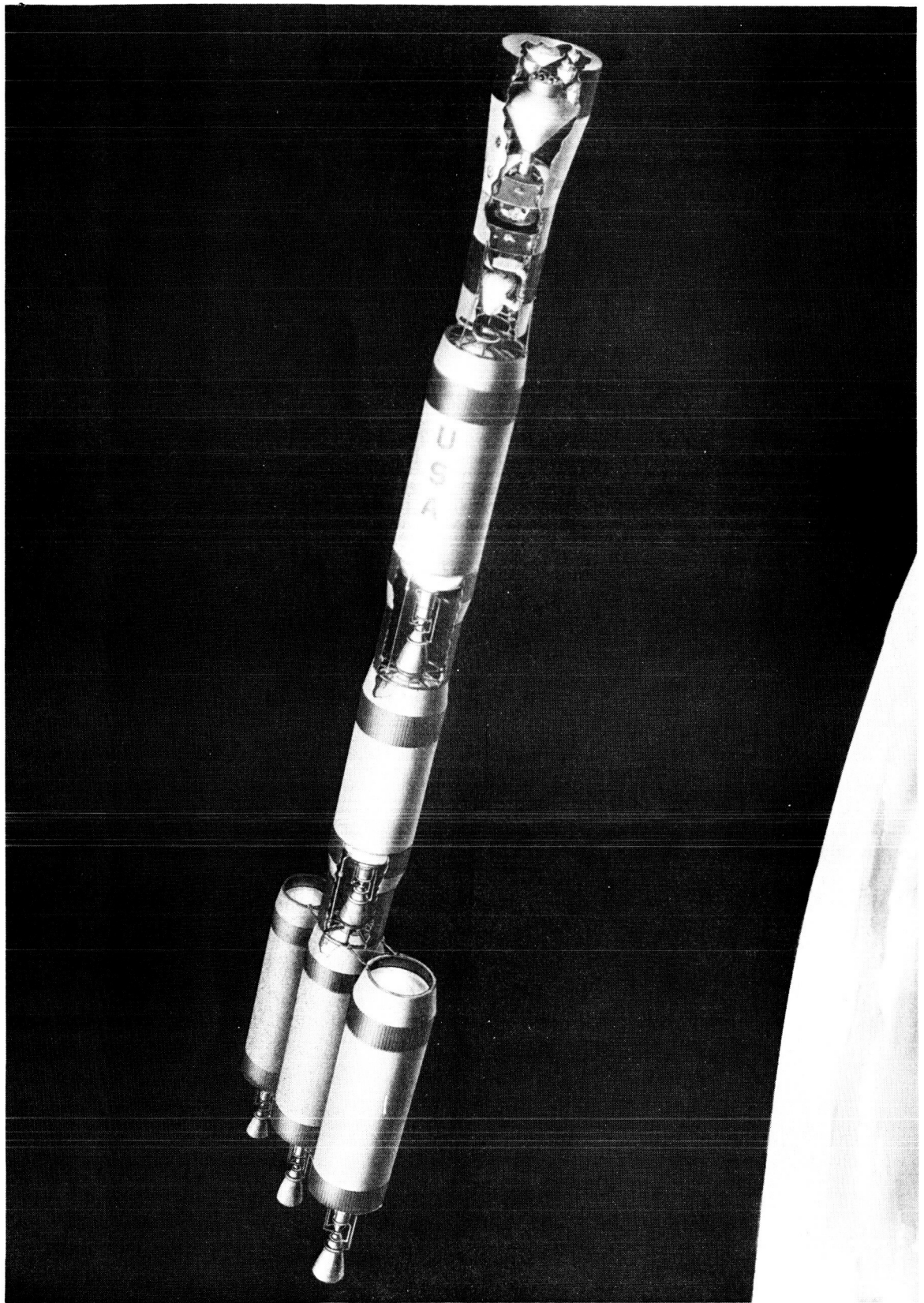

PRECEDING PAGE BLANK NOT FILMED.

ABSTRACT

This document investigates various ways of accomplishing power generation, waste water reclamation, environmental control, attitude control, and communications functions on manned space missions. Preferred concepts are identified by cost-effectiveness analyses, and a plan of evolutionary development is proposed for the preferred concepts. The subsystem analyses are conducted for an assumed flight program of four National Space Station missions and four interplanetary missions within the 1975 to 1990 time period.

FOREWORD

This study was performed by The Boeing Company for the National Aeronautics and Space Administration, Langley Research Center, under Contract NAS1-6774. The Integrated Manned Interplanetary Spacecraft Concept Definition Study was a 14-month effort to determine whether a variety of manned space missions to Mars and Venus could be accomplished with common flight hardware and to define that hardware and its mission requirements and capabilities. The investigation included analyses and trade studies associated with the entire mission system: the spacecraft; launch vehicle; ground, orbital, and flight systems; operations; utility; experiments; possible development schedules; and estimated costs.

The results discussed in this volume are based on extensive total system trades which can be found in the remaining volumes of this report. Attention is drawn to Volume II which has been especially prepared to serve as a handbook for planners of future manned planetary missions.

The final report is comprised of the following documents, in which the individual elements of the study are discussed as shown:

<u>Volume</u>	<u>Title</u>	<u>Part</u>	<u>Report No.</u>
I	Summary		D2-113544-1
II	System Assessment and Sensitivities		D2-113544-2
III	System Analysis	Part 1--Missions and Operations	D2-113544-3-1
		Part 2--Experiment Program	D2-113544-3-2
IV	System Definition		D2-113544-4
V	Program Plans and Costs		D2-113544-5
VI	Cost-Effective Subsystem Selection and Evolutionary Development		D2-113544-6

The accompanying matrix is a cross-reference of subjects in the various volumes.

STUDY AREAS	DOCUMENTATION					
	Volume I / D2-113544-1 Summary Report	Volume II / D2-113544-2 System Assessment and Sensitivities	Volume III / D2-113544-3 System Analysis	Part 1 - Missions and Operations Part 2 - Experiment Program	Volume IV / D2-113544-4 System Definition	Volume V / D2-113544-5 Program Plans and Cost
<ul style="list-style-type: none"> ● Primary Discussion X Summary or Supplemental Discussion 						
MISSION ANALYSIS	X			●		
Trajectories and Orbits	X	X		●	X	
Mission and Crew Operations	X	X		●	X	
Mission Success and Crew Safety Analysis	X	X		●	X	
Environment	X	X		●		
Scientific Objectives	X	X		●		
Manned Experiment Program	X	X		●		
Experiment Payloads and Requirements	X	X		●		
DESIGN ANALYSIS	X				●	
Space Vehicle	X				●	
Spacecraft Systems	X				●	
Configurations	X	X			●	
Subsystems	X	X			●	
Redundancy and Maintenance	X				●	
Radiation Protection	X				●	
Meteoroid Protection	X				●	
Trades	X				●	
Experiment Accommodations	X				●	
Space Acceleration Systems	X				●	
Primary Propulsion--Nuclear	X	X			●	
Secondary Propulsion--Chemical	X	X			●	
System and Element Weights	X	X			●	
IMEO Computer Program	X	X			●	
Earth Orbit Operations and Assembly Equip.	X	X			●	
Earth Launch Vehicles	X	X			●	
Facilities	X	X			●	
System Trades	X				●	
Space Acceleration--Earth Launch Vehicle	X				●	
Space Acceleration Commonality	X				●	
Space Vehicle--Artificial Gravity	X				●	
SYSTEM AND PROGRAM ASSESSMENT	X	●				
System Capability	X	●		●	X	
Design Sensitivities	X	●				
Program Sensitivities	X	●				
Adaptability to Other Space Programs	X	●				
Impact on Other Space Programs	X	●				
Technology Implications	X	●				
Future Sensitivity Studies	X	●				
Program Schedules and Plans	X	X			●	
Test Program	X	X			●	
Facilities Plan	X	X			●	
Program Cost	X	X			●	
Cost Effective Subsystems	X	X				●

ABBREVIATIONS

A.U.	Astronomical unit
bps	Bits per second
C/O	Checkout
CM	Command module (Apollo program)
CMG	Control moment gyro
CONJ	Conjunction
CSM	Command service module (Apollo program)
ΔV	Incremental velocity
DSIF	Deep Space Instrumentation Facility
DSN	Deep Space Network
\oplus	Earth
ECLS	Environmental control life support system
ECS	Environmental control system
EEM	Earth entry module
ELV	Earth launch vehicle
EMOS	Earth mean orbital speed
EVA	Extravehicular activity
FY	Fiscal year
fps	feet/sec
GSE	Ground support equipment
IBMC	Inbound midcourse correction
IMIEO	Initial mass in Earth orbit
IMISCD	Integrated Manned Interplanetary Spacecraft Concept Definition
I_{sp}	Specific impulse
IU	Instrument unit
KSC	Kennedy Space Center
λ'	Ratio of propellant weight to overall propulsion module weight
LC	Launch complex
LC-34 & -37	Launch complexes for Saturn IB
LC-39	Launch complex for Saturn V
LH ₂	Liquid hydrogen
LO	Long
LO ₂ or LOX	Liquid oxygen
LRC	Langley Research Center

ABBREVIATIONS (Continued)

LSS	Life support system
LUT	Launch umbilical tower
♂	Mars
MEM	Mars excursion module
MIMIEO	Minimum initial mass in Earth orbit
MM	Mission module
MODAP	Modified Apollo
MSC	Manned Spacecraft Center (Houston)
MSFC	Marshall Space Flight Center (Huntsville)
MTF	Mississippi Test Facility
NAC	Letters designate the type of acceleration systems First letter--Earth orbit depart Second--planetary deceleration Third--planet escape Example: NAC = Nuclear Earth depart/aerobraker deceleration at planet/chemical planet escape
OBMC	Outbound midcourse correction
OPP	Opposition
OT	Orbit trim
P/L	Payload
PM-1	Propulsion module, Earth orbit escape
PM-2	Propulsion module, planet braking
PM-3	Propulsion module, planet escape
RCS	Reaction control system
SA	Space acceleration
S/C	Spacecraft
S-IC	First stage of Saturn V
S-II	Second stage of Saturn V
SH	Short
SOA	State of art
SRM	Solid rocket motor
S/V	Space vehicle
SWBY	Swingby

ABBREVIATIONS (Continued)

T/M	Telemetry
TVC	Thrust vector control
VAB	Vehicle assembly building
♀	Venus
V _{HP}	Hyperbolic excess velocity

CONVERSION FACTORS
English to International Units

<u>Physical Quantity</u>	<u>English Units</u>	<u>International Units</u>	<u>Multiply by</u>
Acceleration	ft/sec ²	m/sec ²	3.048x10 ⁻¹
Area	ft ²	m ²	9.29x10 ⁻²
	in ²	m ²	6.45x10 ⁻⁴
Density	lb/ft ³	Kg/m ²	16.02
	lb/in ³	Kg/m ²	2.77x10 ⁴
Energy	Btu	Joule	1.055x10 ³
Force	lbf	Newton	4.448
Length	ft	m	3.048x10 ⁻¹
	n.mi.	m	1.852x10 ³
Power	Btu/sec	watt	1.054x10 ³
	Btu/min	watt	17.57
	Btu/hr	watt	2.93x10 ⁻¹
Pressure	Atmosphere	Newton/m ²	1.01x10 ³
	lbf/in ²	Newton/m ²	6.89x10 ³
	lbf/ft ²	Newton/m ²	47.88
Speed	ft/sec (fps)	m/sec	3.048x10 ⁻¹
Volume	in ³	m ³	1.64x10 ⁻⁵
	ft ³	m ³	2.83x10 ⁻²

CONTENTS

	<u>Page</u>
1.0 INTRODUCTION	1
2.0 PURPOSE	3
3.0 SCOPE	5
4.0 STUDY CONCLUSIONS	7
4.1 General Conclusions	7
4.2 Specific Conclusions	7
4.2.1 Electrical Power Subsystem	7
4.2.2 Environmental Control Subsystem	8
4.2.3 Communications Subsystem	8
4.2.4 Water Management Subsystem	8
4.2.5 Space Flight Control Subsystem	9
4.3 Recommendations for Further Study	9
5.0 STUDY CONSTANTS	11
5.1 Flight Program Used For Study	11
5.2 Development of Transportation Costs (Acceleration Costs)	15
5.2.1 Acceleration Cost to Earth Orbit	15
5.2.2 Common Space Propulsion Module Costs	15
5.2.3 Acceleration Cost -- Earth Launch and Earth Orbit Departure	15
5.2.4 Acceleration Cost -- Earth Launch, Earth Departure, and Planetary Braking	16
5.2.5 Acceleration Cost for Planetary Capture and Departure	17
5.3 Assumptions: Technical and Quantitative	17
5.4 Maintenance, Reliability, and Spares	18
6.0 STUDY RATIONALE	21
7.0 SUBSYSTEM RECOMMENDATIONS	25
7.1 Electrical Power Subsystem	25
7.1.1 Recommended Electrical Power Concept	25
7.1.2 Basis for Recommendation of the 8-Mil Silicon Roll-Up Array Concept	26
7.1.3 Topics for Further Study	30
7.1.4 Description of Recommended Electrical Power Subsystem	30
7.2 Environmental Control Subsystem (ECS)	33
7.2.1 Recommended ECS Concept	33
7.2.2 Basis for Recommendation of the Electrodialyses/ Bosch Concept	33

CONTENTS (Continued)

	<u>Page</u>
7.2.3 Description of Recommended Subsystem	37
7.2.4 Discussion and Further Recommendations	37
7.3 Communications Subsystem	41
7.3.1 Determination of an Optimal Interplanetary Radio Frequency Communication Subsystem	41
7.3.2 Laser versus Radio Frequency Communications	43
7.3.3 Recommendations for Further Study	43
7.4 Water Management Subsystem	46
7.4.1 Selected Water Management Concept	46
7.4.2 Basis for Recommendation of the Water Management Development Program	49
7.4.3 Description of the Electrodialysis/Vacuum Compression Distillation Water Management Subsystem	52
7.5 Space Flight Control Subsystem	52
7.5.1 Recommended Space Flight Control Subsystem	53
7.5.2 Basis for Recommendation of RCJ Space Flight Control Concept	55
7.5.3 Description of Recommended Spaceflight Control Subsystem	57
8.0 EVOLUTIONARY SUBSYSTEM DEVELOPMENT PROGRAMS	59
8.1 Electrical Power Subsystem	59
8.2 Environmental Control Subsystem (ECS)	60
8.3 Communications Subsystem	60
8.4 Water Management Subsystem	64
8.5 Spaceflight Control Subsystem	64
9.0 REFERENCES	67
APPENDIX A: STUDY OF ELECTRICAL POWER SUBSYSTEMS	71
APPENDIX B: STUDY OF ENVIRONMENTAL CONTROL SUBSYSTEMS	131
APPENDIX C: STUDY OF THE COMMUNICATIONS SUBSYSTEM	181
APPENDIX D: STUDY OF WATER MANAGEMENT SUBSYSTEMS	215
APPENDIX E: STUDY OF SPACE FLIGHT CONTROL SUBSYSTEMS	251

1.0 INTRODUCTION

The study reported in this document was conducted as a parallel effort to the Integrated Manned Interplanetary Spacecraft Concept Definition Study, under a contract amendment. There are some differences between the subsystems recommended in this document and the subsystems used in the basic study. These differences should not be construed as incompatibilities between the two efforts. This study makes recommendations based on cost effectiveness, and operational factors, which cannot be related to cost at this time, are identified but were not considered in the choice of recommended subsystems. The subsystems used in the basic study were selected considering these qualitative factors as well as cost. In some cases the qualitative factors were judged to be relatively more important than cost, which accounts for some points of apparent difference between the two studies.

As a system progresses from the conceptual stage toward operational hardware, critical decisions must be made that influence the hardware to be developed. In the last decade the decision-making process has been somewhat defined and formalized for the development of Earth-bound systems. For example, the cost-effectiveness methodology has been found to be a valuable tool, when properly used, in selecting and developing operational systems at reasonable cost.

The decision-making process used to select and develop space systems and subsystems can benefit through the application of the cost-effectiveness methodology. The cost-effectiveness approach to space system and subsystem selection should be used as an indicator rather than a determinant for the following reasons. First, there are inherent uncertainties in the economic assessment of any future program. Second, the lack of proven techniques and historical data limits the costing state of art for space programs. Finally, systems and subsystems may not be described in sufficient detail (and in some cases the requirements are not fixed) to permit accurate costing at the time a selection decision is to be made.

A preliminary step toward the cost-effective selection of spacecraft subsystems is provided in this volume. The study reported herein applies cost-effectiveness methodology to the selection of optimal spacecraft subsystems. In particular it considers the optimal selection of electrical power, environmental control, communications, water management, and space flight control subsystem elements.



D2-113544-6

2.0 PURPOSE

The objective of this study is to develop a plan of subsystem development reflecting the optimum utilization of the Apollo Applications and/or a National Space Station program for subsystems qualification. As a pre-requisite step to the objective, candidate methods of accomplishing various spacecraft subsystem functions are identified. The study, therefore, recommends the most cost-effective candidate for each subsystem and proposes plans of evolutionary development for the recommended concepts.

The recommendations made in this study are based primarily on relative costs. The current technology in cost estimating is not sufficiently advanced to include every eventual cost. Therefore, optimal selections cannot be made on the basis of cost alone. Such factors as hardware complexity, operational suitability and flexibility, inherent reliability, and integration into the complete system must be considered. However, to make a selection based completely on engineering factors without a clear understanding of the cost implications of such a decision can lead to procurement of subsystems with unduly high cost.

For the above reasons, this study can be used as a guide to subsystem selection, if the user wishes to make his own evaluations. The relative costs for different subsystem concepts are shown, so that a selection based on engineering judgment can be related to a cost difference. In addition, this study provides a methodology by which other concepts, not evaluated here, can be compared.



PRECEDING PAGE BLANK NOT FILMED,

D2-113544-6

3.0 SCOPE

The study effort concentrated on certain mission module (MM) subsystems. These subsystems are communications, environmental control, electrical power, water management, and space flight control. These subsystems were selected for study because they might differ significantly between an interplanetary mission program and a program of National Space Station (NSS) missions. Such differences could have a significant effect on the total cost of the national space program, in that development costs could be reduced by selection of subsystem concepts common to both NSS and interplanetary missions.



4.0 STUDY CONCLUSIONS

The conclusions to be drawn from this study can be categorized in three ways: general conclusions independent of subsystem considerations; specific conclusions related to a specific subsystem or to other detailed study investigations; and areas where further investigation is required.

4.1 GENERAL CONCLUSIONS

Selection and development of common hardware to perform the same function for interplanetary as well as National Space Station (NSS) missions results in lower total cost to the nation by effective use of R&D funds.

It is possible to select common hardware for similar interplanetary and NSS functions without seriously compromising the performance of the hardware for any specific mission.

With an integrated development program, NSS missions can be used to qualify subsystems and individual hardware items for later interplanetary flights.

Acceleration cost* for interplanetary missions is a significant and sometimes the determining factor in the recommendation of cost-effective subsystem concepts.

4.2 SPECIFIC CONCLUSIONS

4.2.1 ELECTRICAL POWER SUBSYSTEM

For missions to the inner planets, solar arrays are the most cost-effective electrical power subsystem. For a program of Earth orbital missions and interplanetary missions to Mars and Venus, solar arrays are still the cost-effective concept. However, if Earth orbital missions are considered independent of interplanetary missions, the dynamic concepts, isotope/Brayton cycle in particular, may be less costly than solar arrays.

Solar arrays will probably be less cost-effective than dynamic systems for missions to the outer planets beyond Mars. The effectiveness of arrays decreases with a decrease in solar radiation intensity, thus requiring larger arrays with commensurate weight and unit cost penalties.

*Acceleration cost is the price paid to place mass in a desired trajectory or orbit or upon a planetary body. In more basic terms, it is the price paid to change the velocity of a mass by some increment. The mass to be considered for a subsystem includes the fixed mass of the subsystem, the mass of expendables required by the subsystem, and any mass penalty to be charged to the subsystem (a prorated share of the electrical power subsystem mass, for example). Specific cost of acceleration in \$/lb is developed in Section 5.0.

Selection of solar arrays means accepting certain operational problems characteristic of arrays. These problems, discussed in Section 7.3.2.4, may, in the final analysis, outweigh the lower total cost of the solar array subsystem.

4.2.2 ENVIRONMENTAL CONTROL SUBSYSTEM

The combination of electro dialysis for CO₂ removal and Bosch for CO₂ reduction was chosen because it proved most cost effective for the assumed flight program of four NSS and four interplanetary missions. This choice considers the use of solar arrays for electrical power and a O₂ leakage rate of about two pounds per day.

Optimal selection of an environmental control subsystem is affected by availability of thermal power from other subsystems and, therefore, is dependent on choice of electrical power subsystem; selection is also affected by any daily O₂ requirements in excess of that for the crew.

4.2.3 COMMUNICATIONS SUBSYSTEM

Optimal selection of a primary communications subsystem for interplanetary flights requires quantification of performance requirements. The quantification should be in terms of data transmission rate or bandwidth required at various transmission ranges throughout the mission. Development of the total requirement should consider communications necessary for mission operations and spacecraft control, crew morale, engineering data, and scientific data transmission.

Preliminary investigations indicate that RF (S-band) communications will probably be cost effective to a transmission range of 3×10^8 kilometers (Mars missions) with a data rate of 1×10^6 bits/sec (bps).

When missions to the outer planets are contemplated, the laser communications concept will be competitive with or superior to RF systems. Lasers can transmit high data rates for less power, although tracking and pointing problems are still to be solved.

4.2.4 WATER MANAGEMENT SUBSYSTEM

Any reasonable water recovery method can be selected without significant effect on the cost of the national space program with the exception of electro dialysis, which has a high expendable rate for reclaiming of urine.

Electro dialysis for condensate and wash water recovery with vacuum compression distillation for urine recovery is the least costly concept for the assumed flight program of four NSS missions and four interplanetary missions. This concept is approximately 14 million dollars cheaper than the closest competitor.

Competitive development of electro dialysis/vacuum compression and electro dialysis/air evaporation is desirable. The low R&D and unit costs involved make it feasible to select the best concept for interplanetary flights through a competitive evaluation in a National Space Station.

4.2.5 SPACE FLIGHT CONTROL SUBSYSTEM

Reaction control jets (RCJ) for space flight control are a much less costly method than control moment gyros (CMG) for the performance requirements assumed in this study.

The use of cold gas jets to improve orientation accuracy and limit cycle performance of the RCJ concept should be investigated if tighter performance requirements are necessary. It should not be assumed that tighter requirements dictate the selection of CMG.

4.3 RECOMMENDATIONS FOR FURTHER STUDY

Further study of deep space communications is required to determine at what point laser communications become optimum.

For RF communications, criteria for selection of modulation mode are required.

If a more precise determination of optimum antenna and power amplifier size is required, additional cost data must be developed to determine the relationship of cost to engineering parameters for antennae and amplifiers.

High R&D cost is one major disadvantage of the laser communications concept. Further studies may reveal that this cost can be reduced by using laser technology developed by other government agencies.

The various operational problems associated with solar arrays (Section 7.1.2) require further study to determine if they warrant reevaluation of the use of arrays for manned interplanetary missions.

Development of the molten electrolyte concept of CO₂ removal/O₂ production should be continued because this is potentially the most cost effective and direct approach.

Further study should be devoted to the combined environmental control, water management, and atmosphere supply functions to determine the optimum integrated concept.

5.0 STUDY CONSTANTS

The primary constants of this study are the assumed flight program, developed cost equations and assumptions concerning the details of the space vehicle and the mission. Detailed ground rules and assumptions necessary to the study of a particular subsystem are listed or discussed in the appendices.

5.1 FLIGHT PROGRAM USED FOR STUDY

The flight program shown in Figure 5.1-1 was assumed for the study. Combinations of the missions within the program were used as constants for the total cost equations. A general discussion of each type of mission is provided in Tables 5.1-1, 5.1-2, and 5.1-3.

Table 5.1-1: EARTH ORBITAL MISSION-GENERAL DESCRIPTION

<u>Mission Type:</u>	National Space Station to conduct geocentered, solar system, space, and stellar observations and experiments.
<u>Orientation:</u>	Solar oriented
<u>Solar Distances:</u>	1.0 A.U.
<u>Transmission Distances:</u>	400 nautical miles
<u>Accelerations:</u>	Attitude control and orbit keeping ~ 0.03g No artificial gravity
<u>Earth Orbit:</u>	260 nautical mile altitude Circular orbit 50° to 70° inclination Period 1.57 hours Maximum eclipse 0.6 hours
<u>Crew:</u>	6
<u>Resupply:</u>	Designed for 6-month minimum resupply period
<u>Reliability:</u>	0.95 for any length mission through resupply

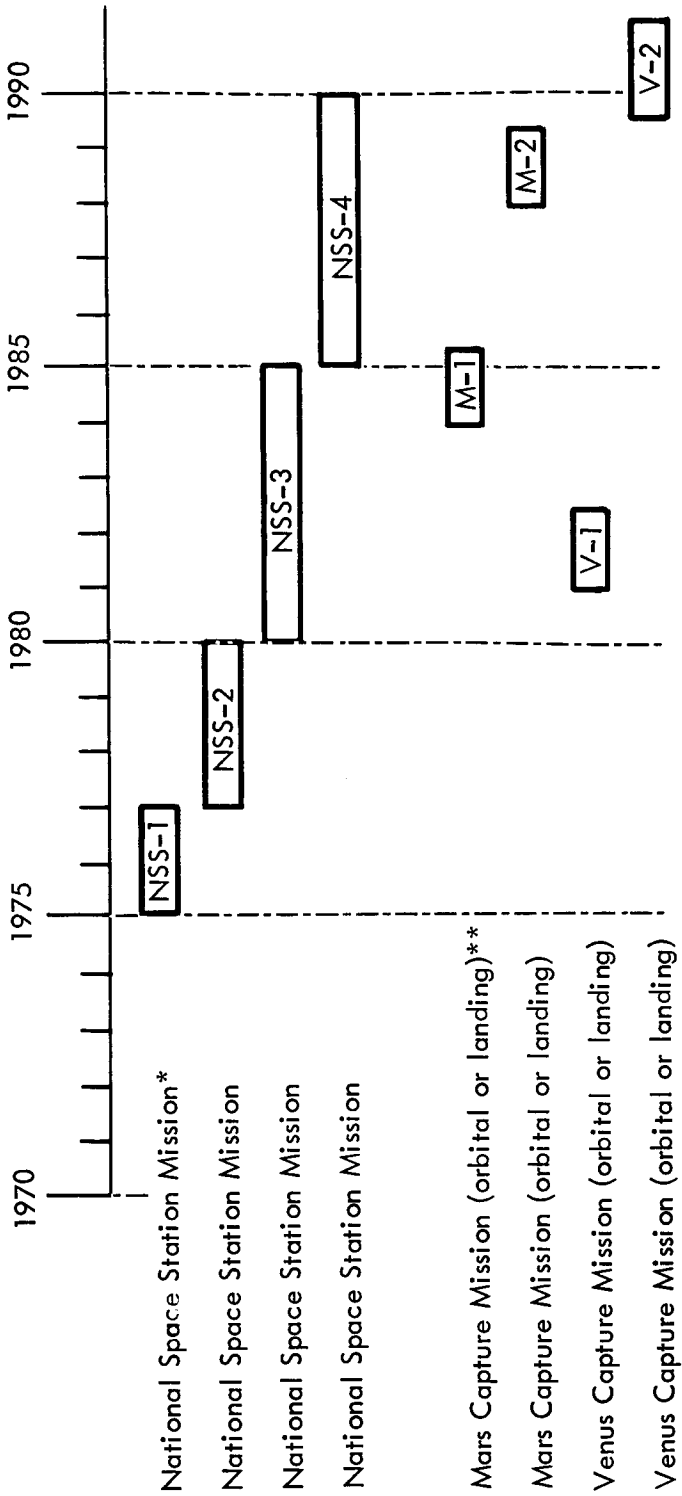

* For National Space Station missions, assume four missions 2, 3, 5, and 5 years long.
 ** For interplanetary missions, assume four missions with an average length of 500 days, which includes leg times of 190 days out, 230 days in, 40 days stay time, and 40 days preparation in Earth orbit.

Figure 5.1-1: ASSUMED TYPICAL FLIGHT PROGRAM

Table 5.1-2. VENUS ORBITAL MISSION--GENERAL DESCRIPTION

<u>Mission Type:</u>	Planetary capture
<u>Orientation:</u>	Planet orientation during Earth orbit, solar oriented during transit to Venus, planet oriented during Venus orbit.
<u>Solar Distances:</u>	Maximum 1.25 A.U. Minimum 0.7 A.U.
<u>Accelerations:</u>	Midcourse correction = 0.1g Attitude control = 0.03g Major accelerations = 1.2g No artificial gravity
<u>Venus Orbit:</u>	1000 kilometer altitude Circular orbit Period 1.83 hours Eclipse 0.61 hours Solar distance 0.72 A.U.
<u>Crew:</u>	6
<u>Resupply:</u>	None
<u>Reliability:</u>	Required probability of mission success = 0.95 after successful injection

Table 5.1-3: MARS ORBITAL OR LANDING MISSION--GENERAL DESCRIPTION

<u>Mission Type:</u>	Planetary capture and landing of an excursion module (This study is not concerned with the landing phase.)
<u>Orientation:</u>	Planet orientation during Earth orbit, solar oriented during transit to Mars; planet oriented during Mars orbit.
<u>Solar Distances:</u>	Maximum 1.67 A.U. Minimum 0.51 A.U.
<u>Transmission Distances:</u>	1.7 A.U. Mars to Earth maximum
<u>Accelerations:</u>	Midcourse corrections = 0.1g Attitude control = 0.03g Major accelerations = 1.2g No artificial gravity
<u>Mars Orbit:</u>	1000 kilometer altitude Circular orbit Period 2.4 hours Eclipse 0.675 hours Solar Distance 1.67 A.U.
<u>Crew:</u>	6
<u>Resupply:</u>	Only in Earth orbit, up to injection minus 1 day
<u>Reliability:</u>	Required probability of mission success = 0.95 after successful injection

5.2 Development of Transportation Costs (Acceleration Costs)--The following cost development is based on the flight program assumed for this study and on the costs of the SAT-V-25(S)U ELV and the common space propulsion module developed for this study.

5.2.1 ACCELERATION COST TO EARTH ORBIT

ELV's Required: (logistics launches excluded)

NSS	4
Interplanetary Missions	23
Spares	6
	<u> </u>
	33

ELV Payload to Earth Orbit: 548.4x10³ lb each

Total Payload Capability = 14,807x10³ lbs

ELV Costs:		<u>Millions</u>
Development*		823.4
Unit Cost	94.3	
Total Unit Costs		3,111.9
Launch Cost/Launch	39.06	
Total Launch Costs		<u>1,054.7</u>
Total ELV Cost		4,990.0
Cost for NSS Missions		739.2
Cost for Interplanetary Missions		4,250.8
Average Cost/lb of Payload Capability to Earth Orbit		\$ 337/lb

5.2.2 COMMON SPACE PROPULSION MODULE COSTS

PM's Required: 19
+11 Spare
 30

PM Costs:		
Development*		4,111.0
Unit Cost	28.5	
Total Unit Cost		855.0
Mission Integration/Launch	6.0	
Total Integration Cost		<u>114.0</u>
Total PM Cost		5,080.0
Average PM Cost per Planned Launch		267.4

*Flight Test cost of ELV included in PM development cost.

5.2.3 ACCELERATION COST--EARTH LAUNCH AND EARTH ORBIT DEPARTURE

PM Units Required:**	11	
Total Cost of PM's		2,941.0
ELV's Required:	19 (for PM and Payloads)	
ELV Total Cost (including launch)		<u>3,511.0</u>
Total Cost for Earth Departure Capability		<u>6,452.0</u>
Payload Capability Assumed for Each PM:	408x10 ³ lb	
Total Payload Capability(8 ELV's):	4387.0x10 ³ lb	
Average Total Cost for Earth Launch and Earth Orbit Departure/lb of Payload Capability		\$1,471/lb

5.2.4 ACCELERATION COST--EARTH LAUNCH, EARTH DEPARTURE, AND PLANETARY BRAKING

PM Units Required:	15	
Total Cost of PM's		4,010.6
ELV's Required:	20 (for PM's and payloads)	
ELV Total Cost (including launch)		<u>3,696.0</u>
Total Cost for Planetary Capture Capability		7,706.6
Payload Capability Assumed*** for Each PM-2:	668.1x10 ³ lb	
Total Payload Capability	2672.2x10 ³ lb	
Average Total Cost for Planetary Capture/lb of Payload Capability		\$2,884/lb

**One mission assumed requires only 2 PM-1's.

***Stage payloads vary with mission.

5.2.5 ACCELERATION COST FOR PLANETARY CAPTURE AND DEPARTURE

Total PM Cost (19 PM's)		5,080.0
Total ELV Cost for Interplanetary Missions	(23)	<u>4,250.8</u>
Total Cost for Planetary Capture and Departure		9,330.8
Payload Capability Assumed for Departure (PM-3)*	133.2x10 ³ lbs	
Total Payload Capability	532.8x10 ³ lbs	
Average Total Cost for Planetary Capture and Departure/pound of Payload Capability		\$17,513/lb

5.3 ASSUMPTIONS: TECHNICAL AND QUANTITATIVE

The technical assumptions made for this amendment study are compatible with the basic IMISCD study (Volumes I, II, III, and IV). The following list of technical and quantitative assumptions includes only those deemed necessary to this study.

- NNN--three nuclear space acceleration modules will be used for the interplanetary missions, providing major ΔV requirements.
- Midcourse ΔV will be accomplished with chemical propulsion modules.
- The SAT V-25(S)U ELV will be used for both interplanetary and Earth-orbital missions.
- A NSS will be in orbit to support all orbital testing of interplanetary subsystems, including space propulsion modules.
- Saturn-V ELV's will be available for logistics support launches.
- The interplanetary spacecraft will be Sun-oriented during transit and planet-oriented in orbit.
- Waste waters, (i.e., condensate, wash, urine, and fecal) will be isolated and recovered separately.
- For the purpose of determining spares, all interplanetary missions are assumed to be 500 days long.
- Leg times for interplanetary missions are assumed to be 190, 40, and 230 days.
- Assume a power penalty of 0.375 lbs/w based on selection of 8-mil solar arrays as the optimum electrical power subsystem (including spares).
- Crew size is six men.
- For thermal integration, waste heat if any, is available only from electrical power subsystem.

*PM-3 payload range is from about 114x10³ to about 150x10³ lbs.

5.4 MAINTENANCE, RELIABILITY, AND SPARES

With the exception of the communications subsystem, reliability of all candidate subsystem concepts will be improved to the same level through the use of spares and repair kits. During the study it became apparent that the communications subsystem could not be evaluated in the same manner as other subsystems. Many hypothetical combinations of antenna and transmitter power amplifiers were used to develop the parametric cost curve shown in Section 7.3.1. Rather than try to estimate the failure rate of each combination, it was assumed that each could be built with the same inherent reliability for the cost estimated.

For other subsystems, spares and repair kits have been determined by an optimal selection program developed by The Boeing Company*. Where the weight of spares is known for some particular mission time, this weight is adjusted by the curve shown in Figure 5.4-1. This curve is used to find the weight of spares and redundancies that will result in the same reliability for a new mission time. The relationship shown in Figure 5.4-1 was derived from information developed in Reference 1.

To establish a point of equivalent performance the following reliabilities are allocated to the subsystems studied. These reliability goals will be achieved in the manner described above.

Environmental Control	0.989
Electrical Power	0.999
Water Management	0.998
Space Flight Control	0.987

*Maintainability and Reliability Cost Effectiveness Program (MARCEP),
D2-22022-7

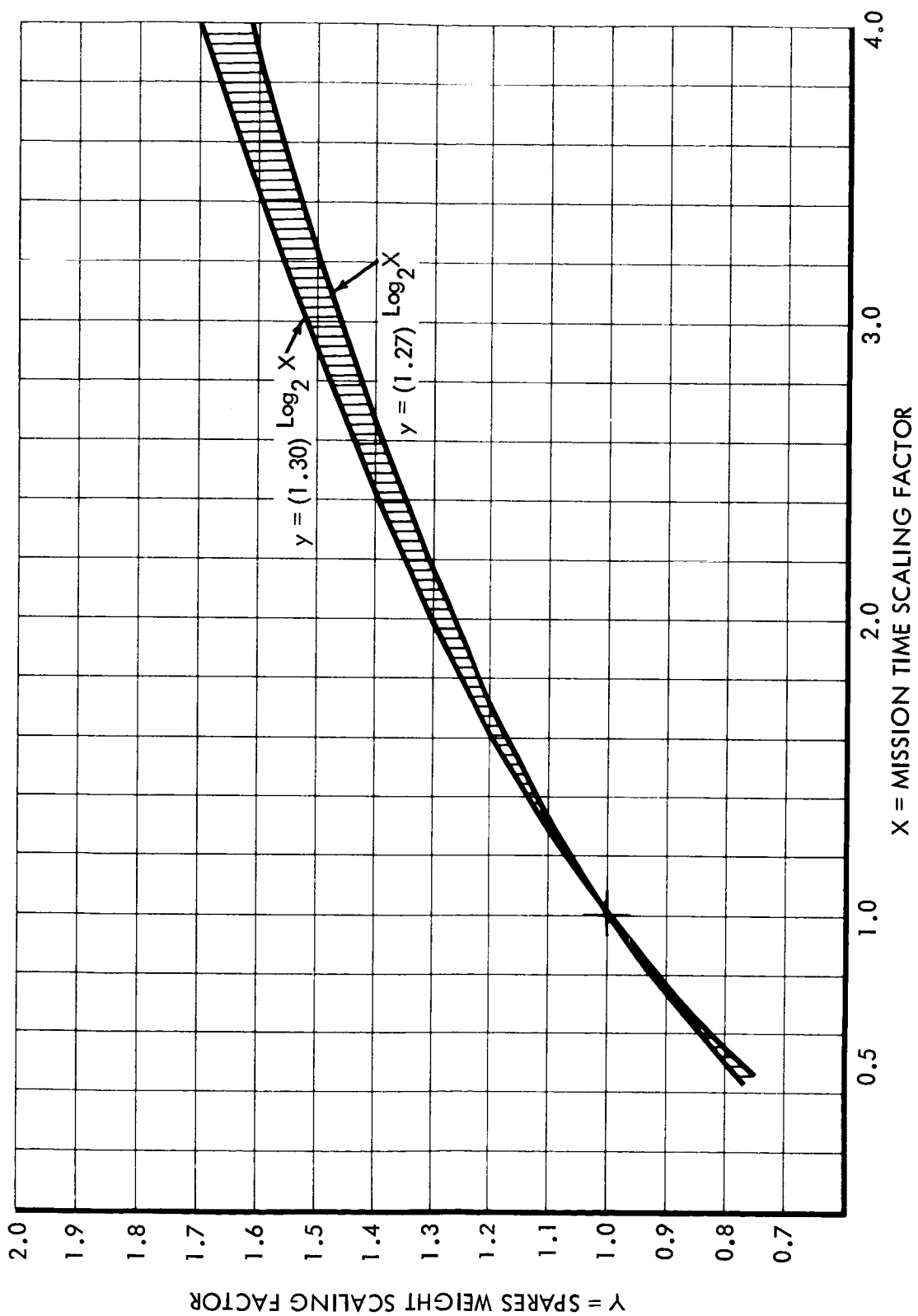

Figure 5.4-1: SPARES AND REDUNDANCIES — WEIGHT SCALING CURVE

6.0 STUDY RATIONALE

The technique employed in the study is illustrated by Figure 6.0-1. The first step for each subsystem was the identification of candidate concepts for cost-effective selection. Reference 3 was used extensively, as well as recommendations by various technology staff groups.

Next, each of the candidates was described in engineering terms. Parameters that might have a significant effect on cost were defined, including quantification of weight, required electrical power, expendable rates, spares weights, and performance parameters to be used in cost estimation. Costs were estimated by the Boeing Space Division Finance Cost Estimating and Research Staff. Quantification of subsystem parameters and description of subsystem operation was obtained from the various references listed, and by work performed specifically for this study by the technical staffs.

Flight program costs were determined by using the following basic equation:

$$C_t = C_{nr} + C_{rec} + C_{acc} + C_{spr}$$

where:

C_t is total program cost, and

C_{nr} = nonrecurring costs

C_{rec} = recurring costs

C_{acc} = acceleration costs

C_{spr} = cost of spares

Nonrecurring costs are the sum of technology development costs and R&D costs. It was found that it is very difficult, if not impossible at present, to estimate technology development costs with any confidence. Therefore, it was decided that technology costs would be assumed to be zero for all concepts to be evaluated.

Recurring costs include the unit costs of the flight articles and the prorated cost of the electrical power required. Prorating electrical power costs (and mass penalty) requires a prior knowledge of the type of electrical power subsystem to be used. For this reason, the electrical power subsystem was the first subsystem evaluated. The recommended subsystem concept cost and mass were used to develop the prorating factors applied to all other subsystem evaluations.

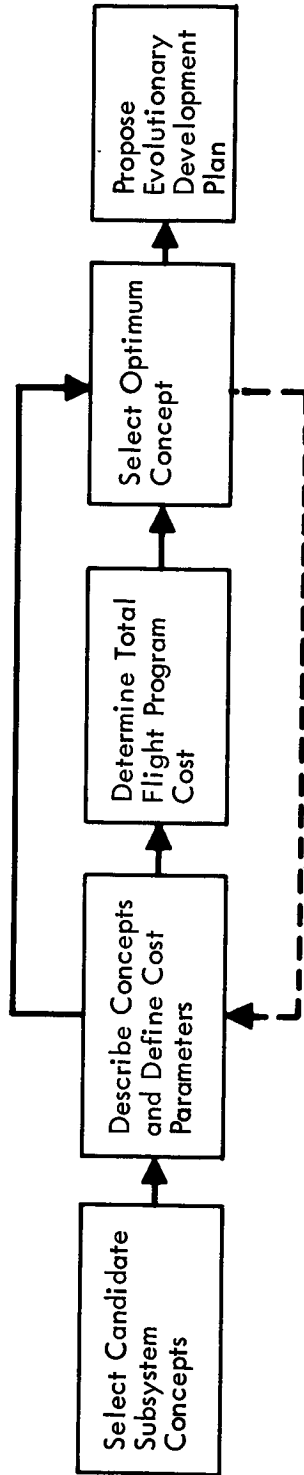

Figure 6.0-1: STUDY RATIONALE

Acceleration costs required a more complex analysis than the other incremental costs. Detailed cost equations used for each of the subsystems are included under Section 4.0 of the appropriate Appendix to this document. Generally, the following factors are considered in determining acceleration costs:

- basic subsystem mass
- expendable rate
- spares mass
- power mass penalty
- number of missions
- subsystem mass changes due to stage separation throughout the mission.

With a cost evaluation complete for a subsystem, the fourth step was selection of the best or cost-effective concept.

The final step of the study rationale was the proposal of a plan of evolutionary development for the chosen subsystem concepts. The proposed plans were developed by collecting information on current or proposed programs, AAP for example, and determining where these programs could be used as a step in the development of the chosen subsystem concept. The proposed flight program, which included four NSS missions and four interplanetary missions, was also considered as a vehicle for evolutionary development. The end product of the evolutionary development program was always assumed to be a subsystem fully qualified for interplanetary flights to the inner planets. To this end, the NSS missions were used as a step in the evolutionary plan. These missions were used to prove interplanetary prototype designs. This is considered to be a reasonable and desirable step because of the lower risk involved with an orbital mission, where the crew can abandon the station in an emergency.

7.0 SUBSYSTEM RECOMMENDATIONS

Recommended concepts for the five subsystems investigated in this study are presented in the following sections, Sections 7.1 through 7.5. Within each section the recommended concept is described and the basis for the recommendation is discussed. Areas for further study or continued consideration are indicated when applicable.

The information presented will enable the user to evaluate the candidate subsystems according to his own judgment, even though a recommendation is made. It is important to take a critical view of the recommended concepts for two reasons. First, in this study there are some subsystem characteristics and parameters that are treated as qualitative factors. After further study these factors may be quantified, and that quantification could possibly have a significant impact on relative costs. For example, it is expected that secondary (infrared) and reflected radiation from the solar arrays will increase the thermal problems associated with cryogenically stored propellants. The extent of this problem and its quantitative effects were not established in this study. When this problem is quantified, additional mass of propellant and/or insulation can be determined and assessed to the solar array electrical power subsystem as a mass penalty. The increased acceleration cost attributed to the assessed mass penalty could be enough to reverse the cost trade between concepts.

Second, some subsystem qualitative characteristics will probably never be quantified, but these factors must be considered in the selection of subsystem concepts. The decision to select or reject a concept on the basis of a qualitative factor requires engineering judgment and insight. For example, solar arrays will undoubtedly interfere with certain scientific observations. The merit of eliminating solar arrays as a concession to scientific observation must ultimately be considered.

7.1 ELECTRICAL POWER SUBSYSTEM

This was the first subsystem investigated, because the specific weight and cost of the selected electrical power concept are required so that optimal selections of the other subsystems can be made. The candidate concepts studied were CdS thin film, 4-mil and 8-mil silicon arrays; isotope/Brayton and Rankine systems; and reactor/Brayton, Rankine, thermoelectric, and thermionic concepts.

7.1.1 RECOMMENDED ELECTRICAL POWER CONCEPT

In general, the solar arrays are recommended because of their low total cost, compared with that of other methods of power generation. Specifically, the 8-mil silicon solar array is recommended. It should be noted, however, that all possible methods of power generation were not evaluated in making this selection. Only those concepts that appeared most promising for the type of missions specified were considered. Of those concepts not considered, and those eliminated during selection,

it is possible that future indepth studies and technological developments may necessitate a reevaluation, but it does not seem likely that future developments can overcome the cost advantage of the selected concept in time to be of use in the flight program now planned. Appendix A to this document should be referred to for additional information on the various concepts considered.

7.1.2 BASIS FOR RECOMMENDATION OF THE 8-MIL SILICON ROLL-UP ARRAY CONCEPT

The above concept was selected as optimal because it appeared least costly when considered on an equal performance basis with all of the other candidate concepts.

7.1.2.1 Cost and Cost Trends

Table 7.1-1 summarizes the costs for the candidate concepts, assuming the planned flight program of four National Space Station (NSS) missions and four interplanetary missions. It can be seen that acceleration costs are a dominant factor and drive the total cost, making the lighter weight concepts more cost effective. Because of the assumptions made in determining the structural weight of the arrays, it is likely that the weight of CdS and 4-mil array concepts could be reduced, thereby reducing the acceleration cost. The weight of the 4-mil array would have to be reduced approximately 640 pounds (290 kg) to meet the total cost figure shown for the selected concept. This would be difficult because of the larger array area required for the 4-mil concept.

The sensitivity of the selection to redefinition of the flight program was investigated by assuming curtailed flight programs and determining the total costs for each candidate concept. Table 7.1-2 summarizes these results. As shown in the table, flight programs of 1, 2, 3, and 4 interplanetary missions, assuming 3 and 4 NSS missions, were evaluated. It is readily apparent that the 8-mil array is optimum in all cases. The cost for additional Mars, Venus, or Earth orbital missions is shown at the right of the table. The cost of arrays for the interplanetary missions is lower than any of the other subsystem costs. However, for Earth orbital missions the arrays generally cost more per mission than the dynamic concepts. Apparently, the acceleration cost for interplanetary flight makes the lighter arrays optimum, while for Earth orbital missions the acceleration cost is less significant, and thus unit costs are the determining factor.

7.1.2.2 Availability of the 8-Mil Rollup Silicon Array for the Planned Flight Program

The 8-mil silicon rollup array is perhaps the only concept that can be ready in time for a 1975 NSS mission. In addition to the 1.5-year lead time shown for this concept (Earth orbital mission), from 1 to 2 years should be allowed for system integration and "all-up" testing. In the R&D effort, emphasis must be placed on development of the rollup concept.

Table 7.1-1: ELECTRICAL POWER SUBSYSTEM TOTAL COSTS--BASELINE FLIGHT PROGRAM

Concept	Cost in Millions (to nearest million)						Spares Cost	ΔCost Above Least Cost
	Total Cost	Nonrecurring Cost	Recurring Cost	Acceleration Cost	Recurring Cost	Nonrecurring Cost		
CdS Solar Array	639	89	178	370	2	99		
4-Mil Solar Array	584	85	164	333	2	44		
8-Mil Solar Array	541	81	150	307	2	---		
Isotope/Brayton	798*	101	39*	632	18	250		
Isotope/Rankine	909*	96	35*	749	20	360		
Reactor/Brayton	1238	139	69	1006	18	692		
Reactor/Rankine	1434	128	71	1206	20	885		
Reactor/Thermoelectric	1762	122	80	1537	16	1215		
Reactor/Thermionic	1237	163	103	968	2	696		

*Isotope fuel cost not included

Table 7.1-2: ELECTRICAL POWER TOTAL COSTS FOR FLIGHT PROGRAM VARIATIONS

Concept	Cost in Millions of Dollars												Cost per Venus Mission	Cost per Mars Mission	Cost per NSS Mission
	3 NSS Missions				4 NSS Missions				Number of Interplanetary Missions	Cost per Venus Mission	Cost per Mars Mission	Cost per NSS Mission			
	1	2	3	4	1	2	3	4							
CdS Solar Array	306	389	531	615	329	413	555	639	84	142	23				
4-Mil Solar Array	281	358	485	562	303	380	507	584	77	127	22				
8-Mil Solar Array	261	332	449	521	281	353	469	541	72	116	20				
Isotope/Brayton*	301	463	624	786	313	474	636	798	162	162	12				
Isotope/Rankine*	327	517	704	894	339	529	719	909	190	190	12				
Reactor/Brayton	450	707	964	1221	467	724	981	1238	257	257	17				
Reactor/Rankine	495	802	1109	1415	514	821	1128	1434	306	307	19				
Reactor/Thermoelectric	575	964	1352	1741	596	985	1373	1762	389	388	21				
Reactor/Thermionic	468	718	969	1219	485	736	987	1237	250	251	17				

*Fuel cost not included

A roll-up array is not required for Earth orbital missions because no major accelerations greater than 0.03g are expected. However, the Earth orbital missions should serve as test beds for the interplanetary missions, which require rollup arrays.

7.1.2.3 Qualitative Arguments for Selection of Solar Arrays

- The most important argument in favor of solar arrays is that of simplicity. The solar array is unquestionably more simple than the other candidate concepts, resulting in a higher inherent reliability.
- The Sun is a constant, readily quantifiable, and extremely reliable source of power.
- The electrical output of the arrays can be tailored to provide the most common d.c. level directly without control other than voltage regulation, resulting in lower power conditioning weight than dynamic (a.c.) conversion systems.
- Solar arrays require a minimum of EVA maintenance activity (see Reference 1).

7.1.2.4 Qualitative Arguments Against Selection of Solar Arrays

- Solar arrays present a complication to spacecraft operations and control. The use of arrays (single gimballed) required that the spacecraft attitude be controlled, implying a control penalty to be assessed against the array system. (Such a penalty was not assessed because attitude control is required by other space vehicle subsystems and prorating the array's share would be highly arbitrary.)
- Large arrays will create a hazard to docking maneuvers and extravehicular activity, and will in turn be endangered by such activities.
- It is most probable that arrays will be retracted during interplanetary injection and braking at the target planet and nearly certain that array retraction will be required for departure from the target planet. Retraction before braking is of major operational concern. The array should be retracted as close to the braking maneuver as possible to reduce the time spent on batteries. However, failure of the array to retract would become dangerous to the mission because the braking maneuver could not be delayed to allow man-handling the array into a stowed condition.
- Large arrays will interfere with onboard scientific observations by obstructing the field of view. The attitude required for single gimbal arrays about the target planet may also affect observations of the planet, and design of the photographic equipment.
- Infrared radiation from the arrays will complicate radiator design and thermal control of stored cryogenic propellant.

- Solar arrays are power limited by the intensity of solar radiations, which decreases according to the inverse square law. This means the arrays must increase in size and weight when trips to the outer planets are undertaken. At some point in man's outward investigations, arrays will become too large, heavy, and costly to be considered.

7.1.3 TOPICS FOR FURTHER STUDY

Because of the lead times involved with the reactor and isotope powered subsystems, it seems reasonable to expect that solar arrays will be used for the early near-Earth missions at least. Even so, certain aspects of the solar array subsystems should be studied before a final choice is made.

- The attitude control penalty incurred with the use of large solar arrays requires investigation and quantification.
- The mutual hazards of arrays and extravehicular activity and docking must be evaluated.
- For interplanetary missions, the effect of secondary infrared radiation from the solar arrays on radiator design and cryogenically-stored propellants should be determined.
- The degree to which large solar arrays will interfere with scientific observations should be evaluated.

7.1.4 DESCRIPTION OF RECOMMENDED ELECTRICAL POWER SUBSYSTEM

The 8-mil silicon rollup array electrical power subsystem concept performs three of the four required functions: conversion, control, and distribution. The fourth function, generation, is provided by the Sun. There will be two rollup arrays located 180 degrees apart on either side of the mission module (MM). Each array will be deployed on a telescoping boom. The telescoping sections of the boom will retract into a common boom section that passes through the mission module (unpressurized space). The common boom section will improve the strength of the deployed arrays and make rotation of the arrays possible with a single, uncomplicated, drive mechanism. Figure A-2 in Appendix A illustrates this configuration. Additional information on the array systems is provided in Section A-5.1 of Appendix A, and the 8-mil array is discussed in Section A-5.1.3. A design summary of the 8-mil rollup array is provided as Table 7.1-3. A comparative summary for all concepts investigated is provided as Table 7.1-4, which shows power, weights, lead times, and incremental costs for each concept.

Table 7.1-3: RECOMMENDED ELECTRICAL POWER SUBSYSTEM

Selected Concept:	Roll-out Solar Array (8-Mil Silicon)
Performance:	14.22 kwe continuous in Mars orbit; 0.1g tolerance deployed
Efficiency:	11% at air mass zero and 28°C
Unit Weight:	5254 pounds (2385.3 kg) for Mars mission
Unit Area:	5280 sq ft for Mars mission
Reliability:	0.999 or higher (with spares and array oversizing)
Number of Missions:	8--4 NSS, 4 interplanetary (see figure 5.1-1)
Cost:	R&D $\$80.8 \times 10^6$ Unit Cost $\$20.505 \times 10^6$ Total Flight Program Cost $\$540.0 \times 10^6$
Operational Considerations:	Large arrays present a hazard to assembly and docking maneuvers as well as to EVA. Also, these activities endanger arrays. Roll-up of arrays might be considered on these occasions. Large arrays may also interfere with and affect scientific observations. Solar arrays should require little EVA maintenance.
Development Risk:	Low. R&D emphasis on structure and deployment mechanisms should make a prototype interplanetary array available for use on the 1975 NSS. NSS-1 and -2 should flight qualify the array for interplanetary missions in the early 1980's.
Contributing Programs:	All solar array powered flights, manned and unmanned, as well as present studies (References 7 and 12)
Basis for Selection:	Least cost (see Table 7.7-1), comparatively low complexity, high inherent reliability
Other Concepts Considered for Selection	4-mil and CdS thin film solar arrays; Isotope-Brayton and Rankine systems; Reactor-Brayton and Rankine; thermoelectric and thermionic systems

Table 7.1-4: COMPARATIVE SUMMARY OF ELECTRICAL POWER CONCEPTS

Concept	Power kw	Fixed Weight		Expendable Weight lb (kg)/yr	Spares Weight		Misc Weight lb (kg)	Lead Time		Cost		Spares 10 ³ \$/lb (kg)
		lb (kg)	lb (kg)		yr	yr		R&D yr	R&D millions of dollars	Recurring millions of dollars		
CdS Thin-Film Array												
Mars Orbit	25.51	6,553(2975)	294(133)		411(187)	4	3	88,800	22,205	0.429(0.946)		
Venus Orbit	25.51	3,176(1442)	310(141)		411(187)	5	4		13,701	0.429(0.946)		
Earth Orbit	25.51	3,903(1772)	345(157)/403(183)/1175(533)*	170(77)	411(187)	4	3		16,201	0.429(0.946)		
4-mil Si Array												
Mars Orbit	25.51	5,792(2630)	294(133)		411(187)	3	2	84,800	20,505	0.429(0.946)		
Venus Orbit	25.51	3,204(1455)	310(141)		411(187)	4	3		12,101	0.429(0.946)		
Earth Orbit	25.51	3,532(1604)	345(157)/403(183)/1175(533)*	170(77)	411(187)	3	2		14,808	0.429(0.946)		
8-mil Si Array												
Mars Orbit	25.51	5,254(2385)	294(133)		411(187)		1.5	80,800	18,805	0.429(0.946)		
Venus Orbit	25.51	2,711(1231)	310(141)		411(187)		1.0**		10,801	0.429(0.946)		
Earth Orbit	25.51	3,245(1473)	345(157)/403(183)/1175(533)*	170(77)	411(187)		1.5		13,001	0.429(0.946)		
Isotope-Brayton	18.00***	7,492(3401)	1353(614)			4	7+	101,400	4,900*	1.343(2.520)		
			1556(706)/1786(811)/2151(977)*									
Isotope-Rankine	18.00***	9,017(4094)	1463(664)			3	7+	96,400	4,400*	1.436(3.166)		
			1682(764)/1931(877)/2326(1056)*									
Reactor-Brayton	18.00***	12,722(5776)	1353(614)			3	3.5	138,600	8,600	1.343(2.520)		
			1556(706)/1786(811)/2151(977)*									
Reactor-Rankine	18.00***	15,442(7011)	1463(644)			1.5	3.5	128,100	8,900	1.436(3.166)		
			1682(764)/1931(877)/2326(1056)*									
Reactor-Thermo-electric (SiGe)	18.00***	20,944(9509)	576(260)			1.5	3.5	122,100	10,000	2.935(6.471)		
			658(299)/755(343)/909(413)*									
Reactor-Thermionic	18.00***	13,369(6070)	189(86)			5.0	3.5	163,000	12,900	1.056(2.328)		
			217(99)/249(113)/300(136)*									

*Earth orbit spares (2/3/5 years)
 **For high-temperature capability
 ***Including 3000 thermal watts (integrated)
 + Including fuel availability
 #Fuel cost not included

7.2 ENVIRONMENTAL CONTROL SUBSYSTEM

The carbon dioxide removal and oxygen supply portions of the environmental control subsystem (ECS) were investigated in this study. The candidate concepts considered were:

CO₂ Removal: Molecular Sieves
Solid Amines
Electrodialysis

CO₂ Reduction for O₂ Supply:
Bosch
Sabatier
Solid Electrolyte

CO₂ Removal and Reduction for O₂ Supply:
Molten Electrolyte

O₂ Supply: Subcritical Storage

All the combinations among the CO₂ removal and the CO₂ reduction concepts were considered. The combinations of CO₂ removal concepts and subcritical storage O₂ Supply were also considered. Crew size and cabin leakage are the two most significant design parameters for a given flight program.

The fundamental design requirement was the assumed crew size--six, with the corresponding CO₂ production and O₂ requirement. Additional O₂ to make up for leakage was an additional factor. The effect of thermal integration with the electrical power subsystem was also considered.

7.2.1 RECOMMENDED ECS CONCEPT

The combination of Electrodialysis for CO₂ removal and Bosch for CO₂ reduction is recommended for development.

7.2.2 BASIS FOR RECOMMENDATION OF THE ELECTRODIALYSIS/BOSCH CONCEPT

This concept is recommended for the baseline flight program because current technology is more advanced than others of similar cost and because cost is low.

Since this study selected solar arrays as the most cost-effective electrical power subsystem, there is no waste heat available for thermal integration. This factor, plus metabolic and leakage requirements, influenced the choice for the ECS, though once decided or determined, they could more properly be considered design requirements.

The molten electrolyte concept, though slightly more cost effective than the other concepts, is not recommended because it is still in the basic research stage, whereas the other concepts are not, and because the data utilized here is, consequently, more preliminary than that available for the other concepts. The molten electrolyte concept was included in this study because it is a potentially favorable ECS for later missions if it can be developed.

7.2.2.1 Costs

Total costs* for the candidate concepts for an oxygen requirement of 13.73 pounds/day, no thermal integration, and the planned flight program of four NSS missions and four interplanetary missions are summarized in Table 7.2-1. The top four contenders on a total cost basis are:

1) Molten Electrolyte	\$247 x 10 ⁶
2) Electrodialysis/Bosch	\$267 x 10 ⁶
3) Electrodialysis/Solid Electrolyte	\$276 x 10 ⁶
4) Electrodialysis/Sabatier	\$299 x 10 ⁶

The most expensive concept, Electrodialysis/Subcritical Storage has a cost of \$364.5 x 10⁶. The selected concept is only 7.9% more costly than Molten Electrolyte. The most expensive concept is 36.6% more costly than the selected concept.

Because of the number of missions in the flight program studied, acceleration costs for the total program are high, amounting to from 74 to 95% for the concepts studied. Note that for other subsystems, such as electrical power (see Section 7.1.2.1), the total acceleration cost of a subsystem is the largest cost item even for subsystems that do not carry expendables. In the environmental control subsystem, all concepts require expendables and the expendables are the largest cost item in the total acceleration cost. Table 7.2-2 shows the effect on total costs for variations in the flight program.

7.2.2.2 Development Status

The recommended concept is in second place costwise, but is preferred on the basis of its development status. The molten electrolyte concept is still in the basic research stage, whereas the recommended concept is not. The Bosch process has been well demonstrated in tests, though it has not been flown. The Electrodialysis concept has also been demonstrated a number of times, but not as extensively as the Bosch (see Appendix B-8.0).

*Costs shown are for CO₂ removal and O₂ supply or CO₂ reduction only. These functions represent only a part of a complete ECS; therefore, costs should not be considered as complete ECS costs.

Table 7.2-1: ENVIRONMENTAL CONTROL SUBSYSTEM TOTAL COSTS--BASELINE FLIGHT PROGRAM

O₂ Requirement (pounds/day): 13.73
 Number of NSS Missions: 4
 Number of Interplanetary Missions: 4
 Thermal Integration: None

Concept	Cost in Millions							Ratio: Acceleration Cost to Total Cost
	Total Cost	Nonrecurring Cost	Recurring Cost	Acceleration Cost	Spare Cost	ΔCost Above Least Cost		
Molecular Sieve/Bosch	325.0	15.1	54.2	245.7	1.0	78	0.755	
Molecular Sieve/Sabatier	354.6	11.8	45.2	291.1	6.5	108	0.82	
Molecular Sieve/Solid Electrolyte	336.3	17.6	53.8	249.2	15.7	89	0.74	
Molecular Sieve/ Subcritical Storage	350.4	8.4	7.8	333.7	0.5	103	0.953	
Solid Amines/Bosch	301.1	16.4	48.1	226.9	9.7	54	0.755	
Solid Amines/Sabatier	330.6	13.0	39.0	272.4	6.3	84	0.825	
Solid Amines/Solid Electrolyte	313.5	19.8	47.7	230.4	15.6	67	0.736	
Solid Amines/ Subcritical Storage	353.2	8.7	8.2	335.8	0.4	106	0.951	
Electrodialysis/Bosch	266.8	14.6	41.6	203.6	7.0	20	0.762	
Electrodialysis/ Sabatier	299.3	11.4	32.9	250.3	4.7	52	0.836	
Electrodialysis/Solid Electrolyte	275.6	17.0	41.5	204.5	12.6	29	0.743	
Electrodialysis/ Subcritical Storage	364.5	8.4	12.5	343.4	0.2	118	0.943	
Molten Electrolyte	247.3	19.1	26.6	186.5	15.2	-	0.754	

Table 7.2-2: ENVIRONMENTAL CONTROL* - TOTAL COSTS FOR FLIGHT PROGRAM VARIATIONS

Concept	Cost in Millions of Dollars													ΔPer Interplanetary Mission	** ΔPer NSS Mission
	3 NSS Missions				4 NSS Missions				ΔPer Interplanetary Mission	** ΔPer NSS Mission					
	Number of Interplanetary Missions				Number of Interplanetary Missions										
	1	2	3	4	1	2	3	4							
Molecular Sieve/Bosch	115.3	181.7	248.1	314.5	125.8	192.2	258.6	325.0	66.4	10.5					
Molecular Sieve/Sabatier	120.3	195.0	269.7	344.4	130.4	205.2	279.9	354.6	74.7	10.2					
Molecular Sieve/ Solid Electrolyte	121.6	189.4	257.2	325.0	133.0	200.7	268.6	336.3	67.8	11.3					
Molecular Sieve/ Subcritical Storage	112.3	189.3	266.4	343.4	119.3	196.4	273.4	350.4	77.0	7.0					
Solid Amines/Bosch	108.5	169.5	230.5	291.5	118.1	179.1	240.1	301.1	61.0	9.6					
Solid Amines/Sabatier	113.4	182.7	252.0	321.3	122.7	192.0	261.3	330.6	69.3	9.3					
Solid Amines/ Solid Electrolyte	115.9	178.3	240.7	303.1	126.3	188.7	251.1	313.5	62.4	10.4					
Solid Amines/ Subcritical Storage	113.3	190.9	268.5	346.1	120.4	198.0	275.6	353.2	77.6	7.1					
Electrodialysis/Bosch	95.9	150.1	204.3	258.5	104.2	158.4	212.6	266.8	54.2	8.3					
Electrodialysis/Sabatier	102.1	165.1	228.1	291.1	110.3	173.3	236.3	299.3	63.0	8.2					
Electrodialysis/ Solid Electrolyte	101.5	156.5	211.5	266.4	110.7	165.6	220.6	275.6	55.0	9.1					
Electrodialysis/ Subcritical Storage	117.1	197.0	277.0	356.9	124.7	204.7	284.6	364.5	79.9	7.6					
Molten Electrolyte	93.2	142.0	190.9	239.7	100.8	149.7	198.5	247.3	48.8	7.6					

*13.73 lbs/day O₂ supply, no thermal integration

**three-year mission

7.2.3 DESCRIPTION OF RECOMMENDED SUBSYSTEM

The recommended concept consists of the electro dialysis CO₂ removal process and the Bosch CO₂ reduction process.

CO₂ removal in this concept is accomplished by means of ion exchange reactions which convert the CO₂ to ionic species and by electro dialysis which causes the ionic species to migrate out of absorption zones into concentrator compartments. There the ions react further to reform CO₂ which is routed to the CO₂ reduction equipment.

CO₂ reduction in this concept is accomplished by a catalytic reaction which produces water and carbon. Oxygen is obtained from the water by means of electrolysis.

Complete descriptions appear in Appendix B. Subsystem parameters are summarized in Table 7.2-3. A comparative summary of such items as weight, power, lead times, and incremental costs for the concepts investigated is shown in Table 7.2-4.

7.2.4 DISCUSSION AND FURTHER RECOMMENDATIONS

7.2.4.1 Impact of Thermal Integration

Had an electrical power system with waste heat been selected, a different choice of ECS might have been made. This is not too apparent at the selected O₂ requirement of 13.73 pounds/day. Examination of Table 7.2-5 reveals that with the addition of thermal integration there is no concept that displaces Electro dialysis/Bosch from its cost position. However, at the other two O₂ rates investigated, concepts including molecular sieves come much closer to being least in cost when the system is thermally integrated.

7.2.4.2 Effect of Variation in O₂ Requirement

The cost ranking of the concepts is different for different O₂ requirements in excess of that for the crew. This is primarily due to the Sabatier process which consumes hydrogen. In most cases, the hydrogen makeup is provided by electrolysis of water. The O₂ from the water is available to satisfy part of the O₂ requirement, and there is no need to reduce all the CO₂. The Sabatier process can be used more efficiently when there is a large daily requirement for O₂ in excess of that which is retrieved from the available CO₂.

7.2.4.3 Development Status

The combinations of Molecular Sieve/Sabatier or Molecular Sieve/Subcritical Storage possess the best blend of simplicity, reliability, and development status. One of them would likely be chosen were it not for cost.

Table 7.2-3: RECOMMENDED ENVIRONMENTAL CONTROL SUBSYSTEM

Selected Concept:	Electrodialysis/Bosch						
Performance:	Provides 13.73 pounds (6.23 kg) of O ₂ per day (11.76 pounds daily requirement for 6-man crew plus 1.97 pounds for cabin leakage or other purposes) by removing and reducing all crew-produced CO ₂ (13.8 pounds) and by electrolyzing water						
Unit Weight:	294 pounds (133.3 kg)						
Power Required:	3160 watts						
Expendable Rate:	4.453 pounds/day (makeup water, catalyst, tankage)						
Reliability:	0.989 for any mission						
Number of Missions:	8 (4 National Space Stations, 4 interplanetary) (see Figure 5.1-1)						
Cost:	<table> <tr> <td>R&D</td> <td>\$14.625 x 10⁶</td> </tr> <tr> <td>Unit Cost</td> <td>\$1.237 x 10⁶</td> </tr> <tr> <td>Total Flight Program Cost</td> <td>\$266.8 x 10⁶</td> </tr> </table>	R&D	\$14.625 x 10 ⁶	Unit Cost	\$1.237 x 10 ⁶	Total Flight Program Cost	\$266.8 x 10 ⁶
R&D	\$14.625 x 10 ⁶						
Unit Cost	\$1.237 x 10 ⁶						
Total Flight Program Cost	\$266.8 x 10 ⁶						
Operational Considerations:	Electrodialysis has an advantage over sorption-desorption concepts in that it is a continuous process; for the Bosch process, periodic replacement of poisoned catalyst is necessary, and carbon removal equipment may cause maintenance problems.						
Development Risk:	Moderate. Bosch requires perfection of techniques for removing carbon; electrodialysis requires further development--it has not received the amount of attention that simpler concepts such as molecular sieves have received.						
Contributing Programs:	Prior Bureau of Ships, Air Force and NASA development work on electrodialysis; Four-man Bosch unit developed by General American Transportation Company for Langley Life Support System.						
Basis for Selection:	Low cost. Current technology is more advanced than for others close to it in cost.						
Other Concepts Considered for Selection:	Molecular sieves, solid amines, Sabatier process, solid electrolytes, molten electrolytes, subcritical storage.						

Table 7.2-4: COMPARATIVE SUMMARY OF ENVIRONMENTAL CONTROL CONCEPTS

Concept	Power watts	Fixed Weight lb (kg)	Expendable Rate lb (kg)/day	Spares Weight lb (kg)	Lead Time		Tech	Cost		Spares 10 ³ / lb (kg)
					Tech months	R&D months		R&D millions of dollars	Recurring dollars	
Molecular Sieve Bosch	4015	329 (149)	4.453 (2.020)	240 (109)* 276 (125) / 319 (145) / 384 (174)**	0	30-36	0	15.100	1.307	4.300 (9.480)
Molecular Sieve Sabatier	3510	224 (102)	8.11 (3.68)	171 (78)* 197 (89) / 228 (103) / 274 (124)**	0	18-24	0	11.750	0.815	3.900 (8.600)
Molecular Sieve Solid Electrolyte	3636	399 (181)	4.453 (2.020)	361 (164)* 415 (188) / 479 (217) / 577 (262)**	0	24-30	0	17.600	1.728	4.500 (9.921)
Molecular Sieve Subcritical Storage	398	107 (49)	15.8 (7.2)	94 (43)* 108 (49) / 125 (57) / 150 (68)**	0	24	0	6.700	0.475**** 0.750****	0.500 (1.102)
Solid Amines Bosch	3254	363 (165)	4.453 (2.020)	229 (104)* 263 (119) / 304 (138) / 366 (166)**	0	30-36	0	16.400	1.487	4.400 (9.700)
Solid Amines Sabatier	2749	258 (117)	8.11 (3.68)	160 (73)* 184 (83) / 213 (97) / 256 (116)**	0	24	0	13.000	0.984	4.050 (8.929)
Solid Amines Solid Electrolyte	2875	433 (196)	4.453 (2.020)	350 (159)* 402 (182) / 464 (210) / 559 (254)**	0	24-30	0	19.800	1.923	4.600 (10.141)
Solid Amines Subcritical Storage	429	136 (62)	15.8 (7.2)	83 (38)* 95 (43) / 110 (50) / 132 (60)**	0	24	0	6.800	0.485**** 0.805****	0.490 (1.080)
Electrodialysis Bosch	2643	276 (125)	4.453 (2.020)	154 (70)* 177 (80) / 204 (93) / 246 (112)**	0	30-36	0	14.625	1.237	4.686 (10.333)
Electrodialysis Sabatier	2304	174 (79)	8.11 (3.68)	102 (46)* 117 (53) / 135 (61) / 163 (74)**	0	24	0	11.400	0.782	4.750 (10.474)
Electrodialysis Solid Electrolyte	2399	312 (142)	4.453 (2.020)	238 (108)* 274 (124) / 316 (143) / 381 (173)**	0	24-30	0	17.000	1.701	5.469 (12.059)
Electrodialysis Subcritical Storage	869	86 (39)	15.905 (7.2)	45 (20)* 52 (24) / 60 (27) / 72 (33)**	0	24	0	6.700	0.470**** 0.750****	0.500 (1.102)
Molten Electrolyte	1386	274 (124)	4.73 (2.15)	376 (171)* 432 (196) / 499 (23) / 600 (272)**	48	30	--	14.072	1.144	4.175 (9.204)

No thermal integration
O₂ requirement = 13.73 lb/day

*Mars mission, considered as 500 days for spares calculations
**Earth orbit spares (2/3/5 years)

***Earth-orbital missions
****Mars mission

Table 7.2-5: ENVIRONMENTAL CONTROL - TOTAL COSTS VERSUS O₂ RATE AND THERMAL INTEGRATION

O ₂ Rate lb/day	Thermal Integration	Rank	Concept	Cost (millions)
11.76	with	1	Molten Electrolyte	188
		2	Electrodialysis/Bosch	207
		3	Molecular Sieve/Bosch	221
		4	Solid Amines/Bosch	230
	no	1	Molten Electrolyte	188
		2	Electrodialysis/Bosch	207
		3	Solid Amines/Bosch	242
		4	Solid Amines/Solid Electrolyte	254
13.73	with	1	Molten Electrolyte	247
		2	Electrodialysis/Bosch	267
		3	Electrodialysis/Solid Electrolyte	276
		4	Molecular Sieve/Bosch	281
	no	1	Molten Electrolyte	247
		2	Electrodialysis/Bosch	267
		3	Electrodialysis/Solid Electrolyte	276
		4	Electrodialysis/Sabatier	299
20.06	with	1	Electrodialysis/Sabatier	417
		2	Molecular Sieve/Sabatier	428
		3	Solid Amines/Sabatier	437
		4	Molten Electrolyte	438
	no	1	Electrodialysis/Sabatier	417
		2	Molten Electrolyte	438
		3	Solid Amines/Sabatier	448
		4	Electrodialysis/Bosch	456

7.2.4.4 Further Recommendations

- Consideration should be given to further development of the Molten Electrolyte concept since it is potentially the most favorable in cost. However, it is not likely that it could be ready by the dates projected for the first NSS missions.
- Consideration should be given to carrying a Sabatier reactor as a backup for the Bosch due to its favorable features, including very little additional cost.
- Though the detail analysis in this study was primarily based on costs, the results indicate not too wide a variation in total costs. Close attention should be paid to new cost information as it becomes available and to any changes in requirements, since one of the other concepts could easily become more cost effective.

7.3 COMMUNICATIONS SUBSYSTEM

The major trade for the communications subsystem involves selection of the spacecraft transmitter. This trade is first between the laser and RF transmission concepts, and then between antenna and power amplifier size, assuming the RF concept is preferable to the laser. The difficulty in making these trades lies in selection of a performance requirement. For a manned Mars mission, reasonable arguments can be offered for selection of required bit rates ranging from 1×10^5 BPS to 6×10^6 BPS. For this reason, a parametric approach to optimal determination of the communications subsystem has been employed. Background information used in determining the parametric relationships shown here is provided in Appendix C.

7.3.1 DETERMINATION OF AN OPTIMAL INTERPLANETARY RADIO FREQUENCY COMMUNICATIONS SUBSYSTEM

The first step in determining an optimal RF communications subsystem is establishment of a required rate of information flow (bit rate or bandwidth). The rate of information flow is dependent on such factors as the amount of experimental data generated, the number and quality of photographs, the type of crew communications (TV), and type of navigation and mission control. Once the required bit rate and the transmission range is determined, the required spacecraft effective radiated power (ERP) can be found. Figure 7.3-1 may be used as a guide in determining ERP. This figure presumes S-band communications, reception by a 210-foot DSIF antenna and a bit error rate of 0.005 (P_e). The bit rate/ERP relationship is shown for one type of digital modulation, biorthogonal (16,5) coded phase-shift-keying/phase modulation (PKS/PM). Other types of modulation might be considered, and these would alter the bit rate/ERP relationship. This indicates a lower level trade necessary--that of modulation technique. In this study no investigation of modulation techniques was made, although relative performance is indicated on some figures in Appendix A.

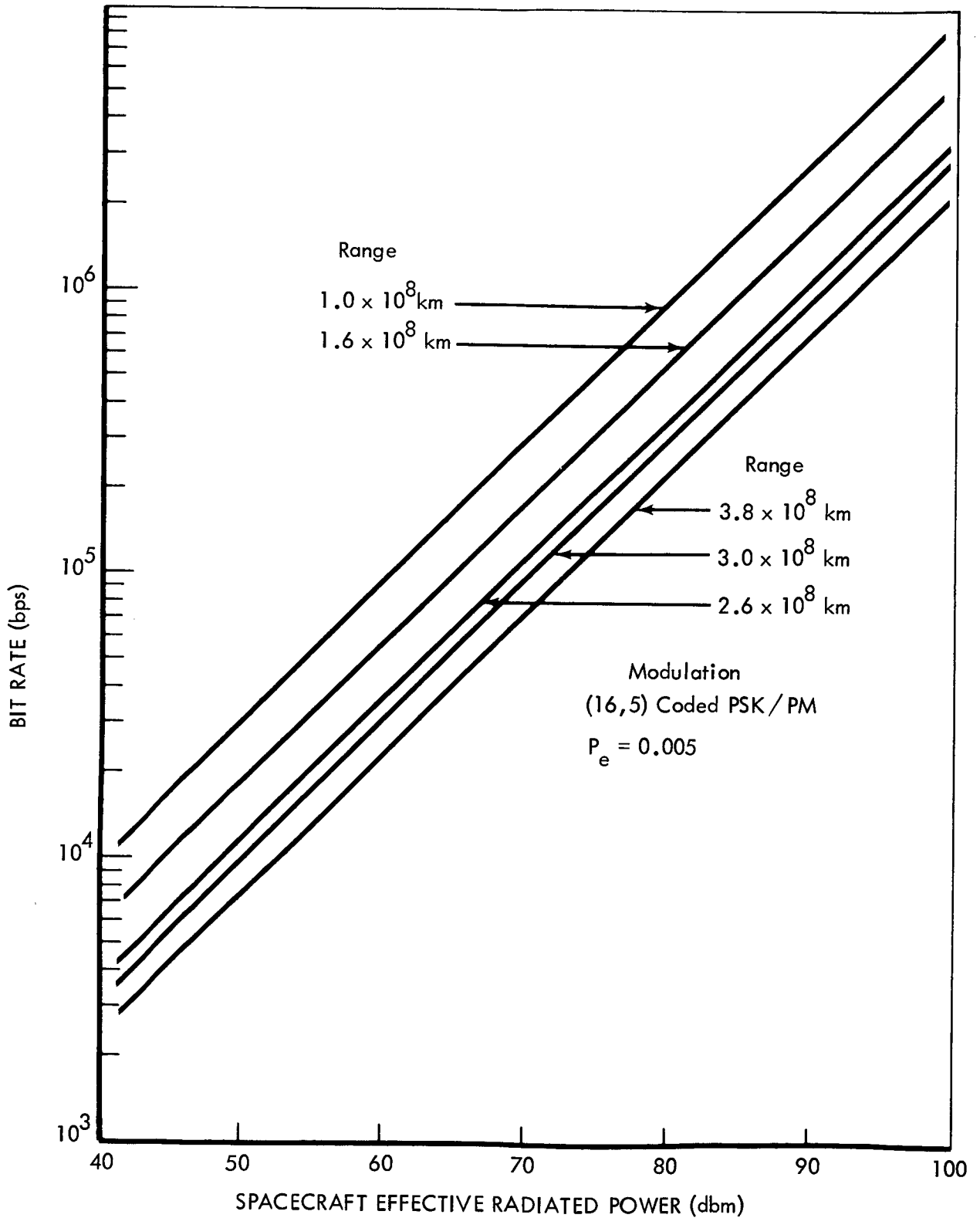

Figure 7.3-1: BIT RATE VERSUS RADIATED POWER (ERP)

With ERP found from Figure 7.3-1, antenna and power amplifier size may be found from Figure 7.3-2. Enter the appropriate ERP cost line on the right of the figure and find the knee of the curve which is the least-cost point. From this point move to the far left scale to find antenna gain, G_0 in decibels. By moving right to the proper ERP line and down, the required transmitter power (P_t) may be found. The ERP curves shown in this figure assume a 4.2 decibel rf loss in the spacecraft and an appropriate antenna pointing loss, which depends on antenna diameter [$G_0 = f(\text{ant. dia})$]. The cost curves are based on four interplanetary missions and include penalties for subsystem weight and power requirement as well as the R&D and unit cost of the equipment. No spares or redundancies were assumed in the subsystems costed; therefore, the reliabilities are not necessarily exactly equal.

7.3.2 LASER VERSUS RADIO FREQUENCY COMMUNICATIONS

When bit rates of 1×10^6 BPS or higher are required at distances of about 3×10^8 kilometers, laser communications should be seriously considered. Figure 7.3-3 shows the performance relationship of laser and RF systems in terms of transmission range and required bit rate. This figure does not consider total flight program cost in evaluating the two concepts.

The laser will probably be heavier than an RF system; however, it will require significantly less power than an RF system at the higher bit rates. The laser is at a cost disadvantage in comparison to the RF system because of the high R&D cost expected. R&D cost for a typical space communications laser system is expected to be about 210 million dollars. If the high cost of R&D can be reduced by drawing on other laser development programs (e.g., Air Force) then the laser may be cost competitive with RF at some lower performance capability.

7.3.3 RECOMMENDATIONS FOR FURTHER STUDY

- As mentioned previously, there is a trade that should be performed on the type of modulation to be used in deep space communications systems. The results of such an investigation should determine the relative merits of the various types of modulation and recommend specific types of modulation desirable for various types of data to be transmitted.
- Development of laser communications should be studied in more detail to identify current programs that could contribute to a deep space laser development program. Laser R&D costs should be reevaluated in the light of such a study to determine if a significant reduction can be achieved.

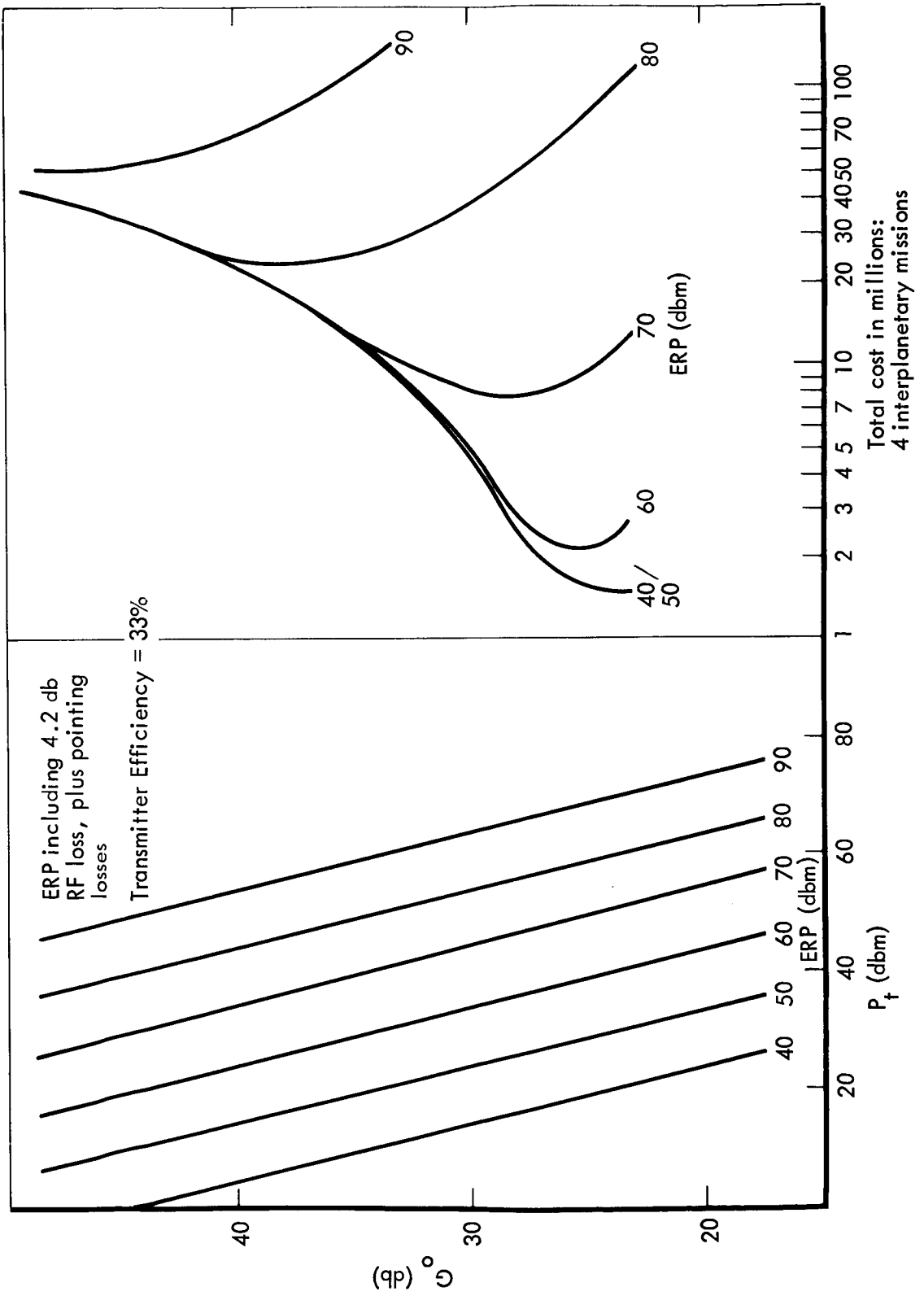

Figure 7.3-2: ANTENNA AND POWER AMPLIFIER COST DETERMINATION

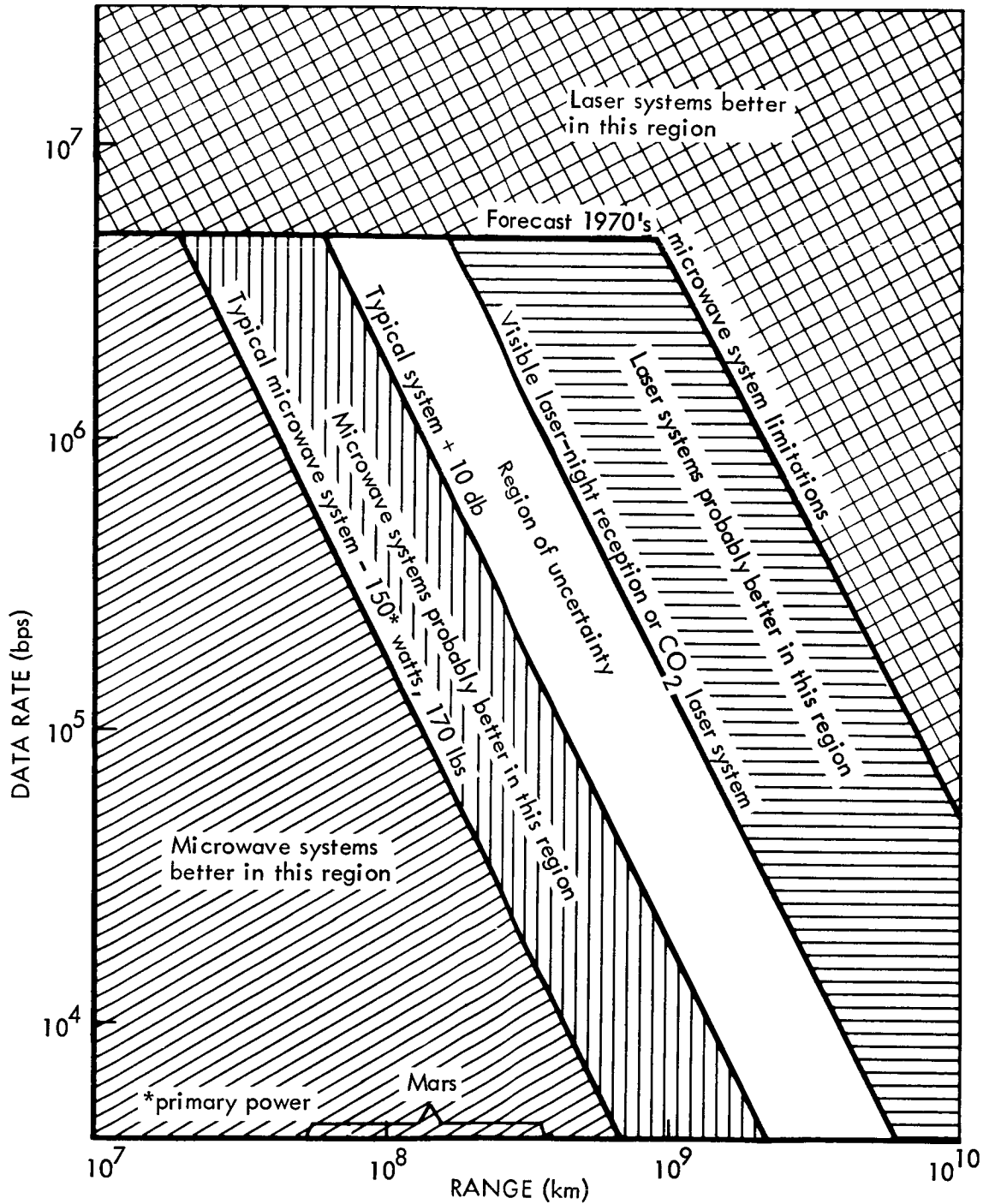

Figure 7.3-3: COMPARATIVE PERFORMANCE OF RF AND LASER DEEP SPACE COMMUNICATIONS SYSTEMS FOR THE MID-1970'S

- In general, parametric costing methods for antennas and transmitters require updating. It is felt that antennae costs (R&D and first article) can be expressed as a function of frequency, antenna gain, and weight. Transmitter power amplifier costs might be expressed as a function of frequency, RF power output, and weight. It was not possible to develop these relationships in this study, although they were desired. Such relationships, if they can be developed, will improve accuracy and increase confidence in the selection of optimum antenna size and amplifier power.

7.4 WATER MANAGEMENT SUBSYSTEM

The water management subsystems studied include processes for the reclamation of condensate, wash water, and urine. The candidate concepts considered for the reclamation processes were multifiltration, air evaporation, vacuum compression distillation, reverse osmosis, and electro-dialysis. Appendix D should be referred to for additional information on these processes.

7.4.1 SELECTED WATER MANAGEMENT CONCEPT

7.4.1.1 Discussion

If least cost is to be the criterion of selection, the combination of electro-dialysis for condensate and for wash water reclamation and vacuum compression distillation for urine recovery should be selected. The cost effectiveness of this subsystem concept is substantiated in Table 7.4-1, which shows the total and incremental costs for all of the candidate subsystem concepts for the baseline flight program.

However, there are factors other than cost to be considered in selecting an optimal concept for any spacecraft subsystem. It is necessary to consider the practicality of the cost optimum subsystem in the spacecraft environment. This consideration, of course, includes evaluation of the inherent simplicity and the operational impact of the choice. Another consideration is the degree to which the subsystem choice can be adapted to changes in subsystem requirements (flow rates, number of crew) and to changes in other interfacing subsystems aboard the spacecraft.

The top four candidate subsystem concepts are listed in Table 7.4-2. It can be seen that the cost difference range is only 18 million dollars, which is a very small percentage of the total flight program cost (which might be 35-40 billion dollars). Also note that choices 2, 3, and 4 include the air evaporation process. The major element of cost for all concepts is acceleration. This cost is not prorated to the spacecraft subsystems in the funding of a space program. It is accounted for as booster and space propulsion module cost. If one chooses to avoid consideration of acceleration cost, the cost range of all the candidates shown on Table 7.4-1 is 3 to 9 million dollars, indicating that the cost penalty for selecting any candidate at random is at most 6 million dollars.

Table 7.4-1: LIFE SUPPORT (WATER MANAGEMENT) SUBSYSTEM TOTAL COSTS--BASELINE FLIGHT PROGRAM

Concept		Cost (to nearest million)						Spares Cost	Acceleration Cost	ΔCost Above Least Cost
Condenser	Wash Urine	Total Cost	Nonrecurring Cost	Recurring Cost	Acceleration Cost	Spares Cost	ΔCost Above Least Cost			
MF	AE	89	1	1	87	<1	34			
MF	VC	91	2	1	187	1	36			
MF	ED	152	2	<1	149	<1	97			
MF	AE	72	1	2	69	<1	17			
MF	VC	80	2	2	174	2	25			
AE	AE	73	1	2	69	1	18			
AE	VC	82	3	2	75	2	27			
VC	VC	87	2	3	80	2	32			
RO	VC	92	3	3	83	3	37			
RO	AE	79	3	3	71	2	24			
RO	VC	81	4	3	71	3	26			
ED	AE	69	<3	2	64	1	14			
ED	VC	76	3	2	69	2	21			
ED	VC	55	3	2	49	1	--			
ED	ED	127	1	1	125	<1	72			

MF - Multifiltration
 ED - Electrodialysis
 AE - Air evaporation
 VC - Vacuum compression
 RO - Reverse osmosis

Table 7.4-2: TOP CANDIDATE WATER MANAGEMENT SUBSYSTEMS

Reclamation Concept			Cost (in millions)						
Condensate	Wash	Urine	Total Cost	Nonrecurring Cost	Recurring Cost	Acceleration Cost	Spares Cost	Cost Above Least Cost	Choice (by cost)
ED	ED	VC	55	3	2	49	1	--	1
ED	AE	AE	69	3	2	64	1	14	2
MF	AE	AE	72	1	2	69	1	17	3
AE	AE	AE	73	1	2	69	1	18	4

It is felt that acceleration cost should not be ignored in making a selection, but it should also be pointed out that the largest part of the acceleration cost can be attributed to the interplanetary missions (\$17,513/lb versus \$337/lb for Earth orbital missions).

7.4.1.2 Recommendation

The above discussion was offered because a competitive development program is recommended, namely, that the first choice subsystem, electro dialysis-electro dialysis-vacuum compression (ED-ED-VC), be developed for the first National Space Station (NSS) mission. The air evaporation (AE) process development should be continued, and an air evaporation unit be included in the first NSS mission. The AE unit would be used in competition with the VC unit to determine the operational practicality of each process in the spacecraft environment. The AE unit would also serve as a backup to the ED-ED-VC system, being able to perform any of the reclamation functions of that system. In the event that development of the electro dialysis process runs into problems, the multifiltration process could easily be substituted for condensate recovery, and the air evaporation process substituted for wash water recovery or wash and condensate recovery. Table 7.4-3 shows the competitive development program recommended.

Table 7.4-3: RECOMMENDED WATER MANAGEMENT SUBSYSTEM DEVELOPMENT PROGRAM

	Waste Water			
	Condensate	Wash	Urine	Fecal
Baseline Development	ED	ED	VC	VC*
Competitive Development			AE	
Alternate Choide 1	ED	AE	AE	
Alternate Choice 2	MF	AE	AE	
Alternate Choice 3	AE	AE	AE	

7.4.1.3 Recommendations for Further Study

It is recommended that methods of personal hygiene and laundering be studied further because these processes may affect the optimal selection of the water management subsystem. This study chose a wash water rate that presumes disposable clothing and moistened pad cleansers for bathing. If other methods are to be used aboard the interplanetary mission spacecraft, the ED-ED-VC water management subsystem may not be the optimal subsystem choice.

It is further recommended that the water management subsystem be investigated in relation to total spacecraft water requirements. In particular, this means that water requirements for Personal Life Support System (PLSS) units should be considered. The amount of water required for these units is dependent on the amount of extravehicular activity (EVA) anticipated. Extravehicular activity required for transfer of supplies, experiments, assembly of new structures, unmanned satellite capture, inspection, and maintenance should be considered in determining the EVA work load. PLSS water requirements can be reduced by (1) development of refrigeration units for the PLSS that do not use water, (2) the use of umbilicals connected to the station or spacecraft subsystems, and (3) recovery of fecal water for use in the PLSS units. It is felt that recovery of fecal water by vacuum compression distillation offers the advantage of reducing the amount of water that must be stored for PLSS units and the advantage of having an additional VC unit aboard that could be used as a backup for the urine recovery unit.

7.4.2 BASIS FOR RECOMMENDATION OF THE WATER MANAGEMENT DEVELOPMENT PROGRAM

The recommended development program was chosen because of cost, practicality, and development risks discussed in the following paragraphs.

*Consider VC for fecal water recovery--recovered water to be used for Personal Life Support System (PLSS) units.

7.4.2.1 Cost and Cost Trends

Table 7.4-4 summarizes the total cost for the 15 candidate water management subsystem concepts. To determine the sensitivity of the candidates to variations in the planned flight program, the combinations of NSS and interplanetary missions shown in the table were investigated. It can be seen that the prime candidate (outlined) is not sensitive to the flight program variations shown. The incremental costs shown on the table indicate the cost per mission for each additional NSS or interplanetary mission after the first one. The additional cost for the interplanetary missions is largely acceleration cost. The low cost of the orbital missions makes a competitive selection program feasible.

7.4.2.2 Availability of Hardware for the Flight Program

None of the processes recommended in Table 7.4-3 should present any problem of hardware availability for a 1975 NSS mission. Development should begin in 1970 to allow for possible slippage and integration of the flight hardware into the space station. The maximum anticipated development time is 29 months for the vacuum compression process.

7.4.2.3 Qualitative Arguments for Electrodialysis/Vacuum Compression as the First Choice Water Management Subsystem

- When combined with a phase change process, such as vacuum compression, electrodialysis is characterized by very low expendable rates for condensate and for wash water reclamation and by high efficiency.
- Vacuum compression distillation will require less periodic servicing than other urine recovery processes. It is expected that removal of dried wastes will be required only every 90 days.
- Vacuum compression can be used to recover fecal water, if this is ever required.
- Vacuum compression has the lowest expendable rate and one of the highest efficiencies for the reclamation of urine.

7.4.2.4 Qualitative Arguments Against Selection of Electrodialysis/Vacuum Compression Distillation

- Electrodialysis is effective in separating only ionized contaminants; therefore, filtration similar to the multifiltration process is required to separate particulate matter and nonionized contaminants. (This fact was considered in developing costs--see Appendix D).
- Vacuum compression hardware is more complex than that of the air evaporation process. Because of mechanical complexity, the VC hardware is likely to present more operational problems and be characterized by a lower inherent reliability.

Table 7.4-4: LIFE SUPPORT (WATER MANAGEMENT) SUBSYSTEM--TOTAL COSTS FOR FLIGHT PROGRAM VARIATIONS

Concept		Cost (to nearest million)												Incremental Costs for each Interplanetary Mission	Incremental Costs for each NSS Mission	
		3 NSS Missions				4 NSS Missions				4 NSS Missions						
		Number of Interplanetary Missions				Number of Interplanetary Missions				Number of Interplanetary Missions						
Condense	Wash	Urine	1	2	3	4	1	2	3	4	1	2	3	4		
MF	MF	AE	26	47	68	88	27	48	68	89	27	48	68	89	21	1
MF	MF	VC	27	48	69	90	28	50	70	91	28	50	70	91	21	1
MF	MF	ED	44	79	114	150	45	81	116	152	45	81	116	152	36	2
MF	AE	AE	21	38	55	71	22	39	56	72	22	39	56	72	17	1
MF	VC	VC	24	42	61	79	25	43	62	80	25	43	62	80	18	1
AE	AE	AE	21	38	55	72	22	39	56	73	22	39	56	73	17	1
AE	AE	VC	26	44	63	81	27	45	64	82	27	45	64	82	18	1
VC	VC	VC	26	46	66	85	27	47	67	87	27	47	67	87	20	1
RO	VC	VC	29	50	71	91	30	51	72	92	30	51	72	92	21	1
RO	RO	AE	25	43	60	78	26	44	61	79	26	44	61	79	18	1
RO	RO	VC	26	44	62	80	27	45	63	81	27	45	63	81	18	1
ED	AE	AE	21	37	53	68	22	38	53	69	22	38	53	69	16	1
ED	VC	VC	24	41	58	76	25	42	59	76	25	42	59	76	17	1
ED	ED	VC	18	30	42	54	19	31	43	55	19	31	43	55	12	1
ED	ED	ED	37	67	96	115	38	68	98	127	38	68	98	127	30	1

MF - Multifiltration
 AE - Air Evaporation
 VC - Vacuum Compression Distillation
 RO - Reverse Osmosis
 ED - Electrodialysis
 NSS- National Space Station

- Vacuum compression process hardware, when sized for a particular waste production rate, is not readily adaptable to increased rates. For example, if the waste rate should be increased by 50%, the VC hardware would have to be doubled as designed, or a new unit would have to be designed. The air evaporation process can adapt to rate changes by increasing the circulation rate and the wick change rate.
- The electro dialysis vacuum compression system is based on batch processes, which are felt to be less desirable than continuous processes.

7.4.3 DESCRIPTION OF THE ELECTRODIALYSIS/VACUUM COMPRESSION DISTILLATION WATER MANAGEMENT SUBSYSTEM

The electro dialysis/vacuum compression distillation water management subsystem recovers water from the three major water wastes: condensate, used wash water, and urine. Recovery of condensate and used wash water is by electrolysis and filtration. Urine is reclaimed by vacuum compression distillation. Discussion of the electro dialysis and vacuum compression concepts is provided in Appendix D, Sections D-5.5 and D-5.3, respectively.

The discussion of the various concepts in Appendix D does not synthesize them into a complete subsystem. Figure 7.4-1 shows how electro dialysis and vacuum compression might be integrated into a water management subsystem. Notice that recovered urine must pass through two reclamation cycles before it becomes potable water. The rates that are shown in Figure 7.4-1 balance, but they do not consider water lost in food preparation, personal hygiene, personal life support system operation, and airlock operation; determination of a true water balance must consider these losses. Table 7.4-5 summarizes the recommended water management subsystem characteristics.

7.5 SPACEFLIGHT CONTROL SUBSYSTEM

The spaceflight control subsystem investigated in this study includes the equipment necessary to control the spacecraft's attitude, or orientation. Two concepts were studied: control moment gyros (CMG) with reaction control jets (RCJ) for large maneuvers, and reaction control jets for all control. The inertia wheel was not studied because of the size required to control the interplanetary vehicles. Detailed information on the concepts studied is provided as Appendix E to this document.

7.5.1 RECOMMENDED SPACEFLIGHT CONTROL SUBSYSTEM

For the flight program assumed in Figure 5.1-1, the RCJ system is recommended. The selection is largely dependent upon the pointing accuracy and orientation requirements of the planned experiment and observation program. The requirements and vehicle parameters specified in Appendix E were derived from the basic study, Volumes I through V. These requirements are about the limit that can be achieved with a bipropellant RCJ

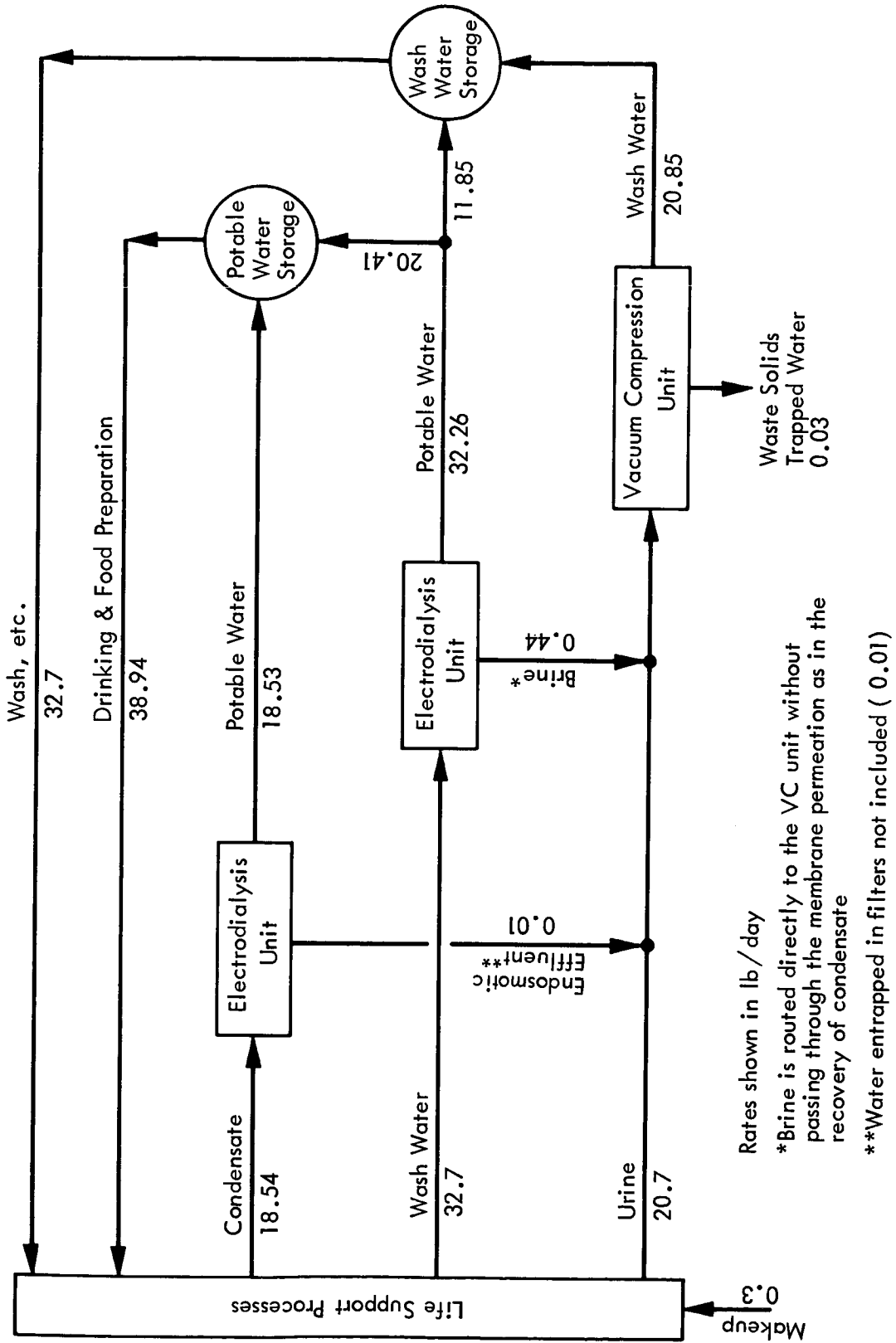

Figure 7.4-1: RECOMMENDED WATER MANAGEMENT CONCEPT

Table 7.4-5: SELECTED WATER MANAGEMENT SUBSYSTEM

<u>Selected Concept:</u>	Electrodialysis/electrodialysis/vacuum compression for condensate, wash water, and urine reclamation, respectively.						
<u>Performance:</u>	18.45 pounds condensate, 32.7 pounds wash, 20.7 pounds urine:/day						
<u>Unit Weight:</u>	28.8, 28.8, 88.46 pounds respectively						
<u>Number of Missions:</u>	8 (See Figure 5.1-1)						
<u>Cost:</u>	<table> <tr> <td>R&D</td> <td>$\\$3 \times 10^6$</td> </tr> <tr> <td>Unit cost</td> <td>$\\$222.8 \times 10^3$</td> </tr> <tr> <td>Total flight program cost</td> <td>$\\$55 \times 10^6$</td> </tr> </table>	R&D	$\$3 \times 10^6$	Unit cost	$\$222.8 \times 10^3$	Total flight program cost	$\$55 \times 10^6$
R&D	$\$3 \times 10^6$						
Unit cost	$\$222.8 \times 10^3$						
Total flight program cost	$\$55 \times 10^6$						
<u>Operational Considerations:</u>	VC requires periodic servicing only every 90 days; however, the mechanical complexity may dictate more frequent attention.						
<u>Development Risk:</u>	Relatively low risk; flight units should be available for a 1975 flight if development is started in 1970						
<u>Contributing Programs:</u>	<p>AF Contract AF33(615)-429, (Ionics, Inc.)</p> <p>NASA Contract NAS1-1225 (General American Transport)</p> <p>NASA Contract NAS9-1680 (Marquardt)</p> <p>NASA Contract NAS9-5119 (Marquardt)</p>						
<u>Basis for Selection:</u>	Least cost and operational practicality. Note that competitive selection of urine reclamation method is recommended.						
<u>Other Concepts Considered for Selection:</u>	See Table D-5, Appendix D						

system. If more stringent requirements are set, the bipropellant RCJ system must be augmented with finer control capability, possible with the use of cold gas RCJ's. This would increase the RCJ development and unit costs, as well as the weight and power requirements, significantly narrowing the cost difference between the two concepts. In the event that more stringent requirements are anticipated, it is advisable that selection of the RCJ subsystem be reevaluated.

7.5.2 BASIS FOR RECOMMENDATION OF RCJ SPACEFLIGHT CONTROL CONCEPT

The primary reason for selection of the RCJ subsystem in preference to the CMG/RCJ concept is the large difference in total cost between the two methods.

7.5.2.1 Cost and Cost Trends

As previously stated, cost determined the selection of the RCJ concept as indicated for the planned flight program in Table 7.5-1, which shows the total and incremental costs for the competitive candidates. The major cost factors driving the selection are nonrecurring costs (R&D cost) and recurring cost (hardware cost). One of the reasons for the high R&D cost for the CMG/RCJ concept is the fact the R&D cost for the RCJ items must be included. These costs are broken down in more detail in Appendix E on Table E-11. In running the cost evaluation, it was assumed that development costs would be those for the interplanetary missions and that this cost would include development of hardware for the NSS missions.

Table 7.5-2 shows the variations in total program cost caused by changes in the planned flight program. The costs for three NSS missions with 1, 2, 3, and 4 interplanetary missions are shown as well as similar costs for four NSS missions. At the right of Table 7.5-2 the costs of one additional NSS or interplanetary mission are shown.

7.5.2.2 Availability of RCJ Hardware for the Planned Flight Program

Because the interplanetary flights may not occur until the 1980's, there should be no problem in obtaining the necessary hardware in time to meet all flight dates. For the 1975 NSS mission, the hardware is virtually off-the-shelf equipment. About 2.5 years will be required to qualify the subsystem, however. For the interplanetary flight, long term methods of bipropellant storage must be developed.

7.5.2.3 Qualitative Arguments for RCJ Spaceflight Control

- For the assumptions made in this study, the RCJ subsystem is lighter than the CMG/RCJ concept.
- Assuming improved thrusters, the RCJ subsystem is likely to require less maintenance than the CMG/RCJ subsystem. The maintenance to be performed on this system is judged to be less difficult and time consuming than on the CMG/RCJ subsystem, where replacement of bearings, drive units, and torquers may be difficult.

Table 7.5-1: SPACEFLIGHT CONTROL SUBSYSTEM COSTS--BASELINE FLIGHT PROGRAM

Concept	Cost (to nearest million)					
	Total Cost	Non-Recurring Cost	Recurring Cost	Acceleration Cost	Spares Cost	ΔCost Above Least Cost
Control Moment Gyro With Reaction Control for Large Moments	335	194	76	36	28	162
Reaction Control Jet System	173	105	27	28	14	---

Table 7.5-2: SPACEFLIGHT CONTROL SUBSYSTEM TOTAL COSTS FOR FLIGHT PROGRAM VARIATIONS

Concept	Cost (in millions)									
	Three NSS Missions				Four NSS Missions				Cost/NSS Mission	Cost/Interplanetary Mission
	Number of Interplanetary Missions				Number of Interplanetary Missions					
	1	2	3	4	1	2	3	4		
Control Moment Gyro With Reaction Control for Large Moments	267	287	308	329	273	294	314	335	6	21
Reaction Control Jet System	147	154	162	170	151	158	166	173	4	7.5

7.5.2.4 Qualitative Arguments Against RCJ Spaceflight Control

- RCJ systems depend on expulsion of mass to achieve control; therefore, the total weight penalty is in part a function of mission duration. For long missions with few major maneuvers required, the CMG's will weigh less.
- The limit cycle performance of RCJ's is inferior to that of CMG's. When high accuracy and limit cycle performance are required, additional reaction control equipment is required (e.g., cold gas thrusters).

7.5.3 DESCRIPTION OF RECOMMENDED SPACEFLIGHT CONTROL SUBSYSTEM

The RCJ spaceflight control subsystem utilizes stored propellants for bipropellant RCJ's. The system arrangement and components, at least for the first NSS missions, will be similar to present proven systems. Subsystem parameters are summarized in Table 7.5-3. A comparative summary of such items as weight, power, lead times, and incremental costs for the concepts investigated is shown in Table 7.5-4.

Table 7.5-3: RECOMMENDED SPACEFLIGHT CONTROL SUBSYSTEM

Selected Concept:	Reaction control jets	
Performance:	10 deg/hr limit cycle rate, $\pm 0.1^\circ$ maximum deadband accuracy	
Reliability:	0.987 for 500 days	
Unit Weight:	579 pounds (263) dry weight	
Number of Missions:	8; 4 NSS and 4 interplanetary	
Cost:	R&D	\$105 x 10 ⁶
	Unit cost	\$3.2 x 10 ⁶
	Total flight program cost	\$173 x 10 ⁶
Operational Considerations:	High precision scientific observations or experiments will require isolation platforms.	
Development Risk:	Low	
Contributing Programs:	All large spacecraft programs, Apollo, Apollo applications, MOL	
Basis for Selection:	Least cost	
Other Concepts Considered for Selection:	Control moment gyros	

Table 7.5-4: COMPARATIVE SUMMARY OF SPACE FLIGHT CONTROL CONCEPTS

Concept	Power watts	Weights										Development Time		Cost					
		Fixed Weight		Expendable Rate	Mission Weights*				Spares Weights				Technology	R&D years	R&D	Recurring	Spare		
		W _f lb (kg)	W _r lb (kg) year		W ₁ lb (kg)	W ₂ lb (kg)	W ₃ lb (kg)	W ₄ lb (kg)	500 days W _{s1} lb (kg)	2 yrs W _{s2} lb (kg)	3 yrs W _{s3} lb (kg)	5 yrs W _{s4} lb (kg)							
RCJ/CMG for NSS	580	435.2 (197.6)	850 (385.9)	—	—	—	—	—	—	—	—	270 (122.6)	313 (142)	374 (169.8)	0	0	90.5	5.4	12.4 (27.3)
RCJ only for NSS	265	486.2 (220.7)	1950 (885.3)	—	—	—	—	—	—	—	—	160 (72.6)	186 (84.4)	223 (101.2)	0	0	96.0	2.9	10.0 (22.0)
RCJ/CMG for Interplanetary	544**	1463.2 (664.3)	—	1355.4 (615.4)	675 (306.5)	133.4 (60.6)	1304.6 (592.3)	235 (106.7)	—	—	—	—	—	—	2	4	194.0	12.3	12.4 (27.3)
RCJ only for Interplanetary	270**	579 (262.9)	—	1373.1 (623.4)	777.6 (353.0)	172.5 (78.3)	634.8 (288.2)	140 (63.6)	—	—	—	—	—	—	2	4	105.0	3.2	10.0 (22.0)

*W₁ = Mass accelerated to Earth orbital velocity
 W₂ = Mass accelerated to Leg 1 (L₁) injection velocity
 W₃ = Mass accelerated to planetary braking ΔV
 W₄ = Mass accelerated to planetary departure ΔV
 **Reflects improved technology for 1984 mission

8.0 EVOLUTIONARY SUBSYSTEM DEVELOPMENT PROGRAMS

The five subsystems considered in this study should be developed on a schedule that permits the National Space Station (NSS) missions to serve as flight qualification for the interplanetary missions. Ideally, the selected concept for each subsystem would fly as the baseline subsystem for the first NSS mission, and undergo redesign, as necessary, for successive missions. In this way, the selected concept would gain flight experience for extended periods of time. Design improvements based on flight experience would make subsystem operation routine for interplanetary missions. In addition, interplanetary flight crew training could use the equipment installed in the NSS to great advantage.

Cognizance must be taken of continuing development in other R&D programs and experience in other precursor and parallel flight programs, both those that use the same subsystem concepts and those that use others. For some of the subsystems, the NSS missions will likely carry backup equipment in the form of hardware with prior flight experience.

Should the first NSS mission prove the selected concept unsatisfactory to the point that a switch should be made, two obvious courses of action are, one, use a previously proven concept with prior flight experience, or two, use an alternative concept that was continued in development because of its promise, possibly one that could not have been readied for the first mission.

Some of the subsystems could be impacted at some time prior to the interplanetary flights by changes in other subsystems, changes in design requirements, and possibly, in some instances, by determination of requirements that do not presently exist. For some of the subsystems, the development program will hinge on certain concepts or components that are known to be current technological problems; thus, the development program for a subsystem may be termed simple, intermediate, or difficult.

8.1 ELECTRICAL POWER SUBSYSTEM

The selected least-cost electrical power subsystem presents no problems that would prevent having it ready for the first NSS mission. Solar arrays of various types have been successfully used in many unmanned space programs. The S-IVB orbital workshop will use a solar panel/battery electrical power subsystem; the panels will most likely be foldable.

The mechanical aspects of the solar array development are expected to require the most effort. The large array area and the requirement for deploying and stowing the solar arrays a large number of times will necessitate a thoroughly-tested and reliable roll-out and roll-up system. This leads to the desirability of a complete and full-size interplanetary prototype on all the NSS missions. A recommended

development program for the electrical power subsystem is shown in Figure 8.1-1.

Though solar cell and battery technology from other programs will be applicable to some extent, the type of panel deployment technique will most likely be unique to this program.

8.2 ENVIRONMENTAL CONTROL SUBSYSTEM (ECS)

The evolutionary development program for the ECS should be aimed at as much Earth-orbital testing as possible prior to the interplanetary missions. CO₂ reduction has not yet been used for manned space flight.

The CO₂ removal concepts competitive for interplanetary missions, including the selected concept, have not yet been used for manned space flights. The R&D program for electro dialysis/Bosch ECS is estimated to be of intermediate difficulty. However, should real problems be encountered, alternates are available. Molecular sieves for CO₂ removal have been tested for a number of years and will probably have undergone flight experience by the end of 1971. As for CO₂ reductions, the Sabatier has undergone considerable ground testing and will probably have been carried as an experiment on AAP or MOL, making it attractive as an alternative or as a backup. Figure 8.2-1 shows evolutionary development of the subsystem.

Development of the molten electrolyte concept could be pursued at a rate that would permit its inclusion as an experiment on NSS-2.

8.3 COMMUNICATIONS SUBSYSTEM

The communications subsystem presents an interesting question as to development plans. Selection of an RF system poses no significant development or scheduling problems. Repackaged Apollo equipment could easily satisfy NSS requirements. Even with no specific use of Apollo equipment, an RF system to be designed for the NSS missions would be a very low risk program.

Selection of a laser communications system poses a more difficult development and schedule problem. First, there is currently no hard requirement or justifiable rationale for the large data transmission rate that would cause selection of laser over RF. Second, an Earth-orbital laser communications system is not only unnecessary for a NSS mission, but also would be quite costly and technologically difficult because of the high relative velocities involved and the quite stringent pointing requirements of lasers. Also, atmospheric interference might necessitate relay satellites. Thus, in contrast to other subsystems such as environmental control or life support, the use of NSS missions to qualify a laser for interplanetary use does not provide a very satisfactory solution for reasons of both cost and dissimilar operating regime. Figure 8.3-1 shows a proposed evolutionary development plan for deep space communications.

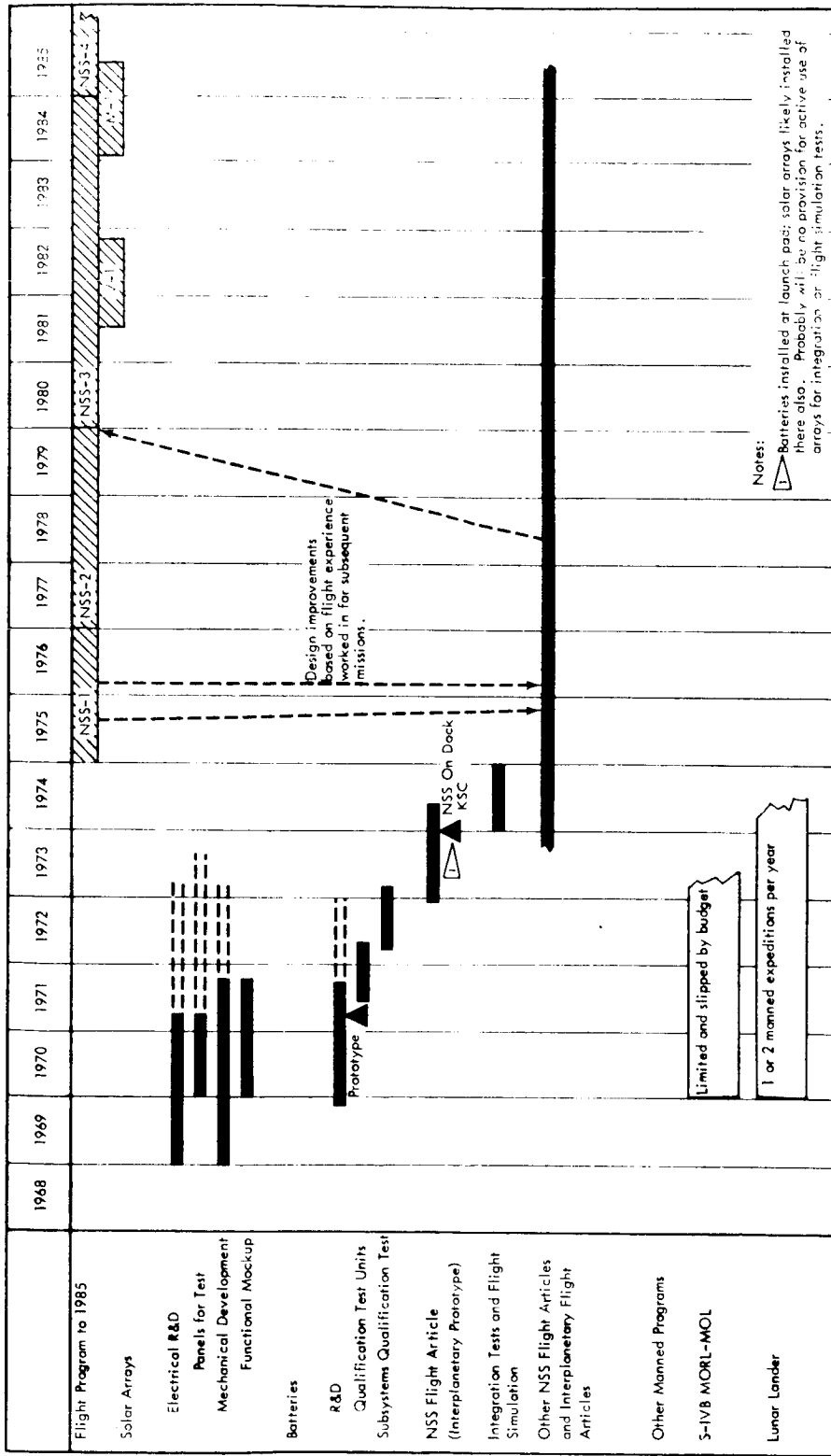

Figure 8.1-1: EVOLUTIONARY DEVELOPMENT OF THE ELECTRICAL POWER SUBSYSTEM

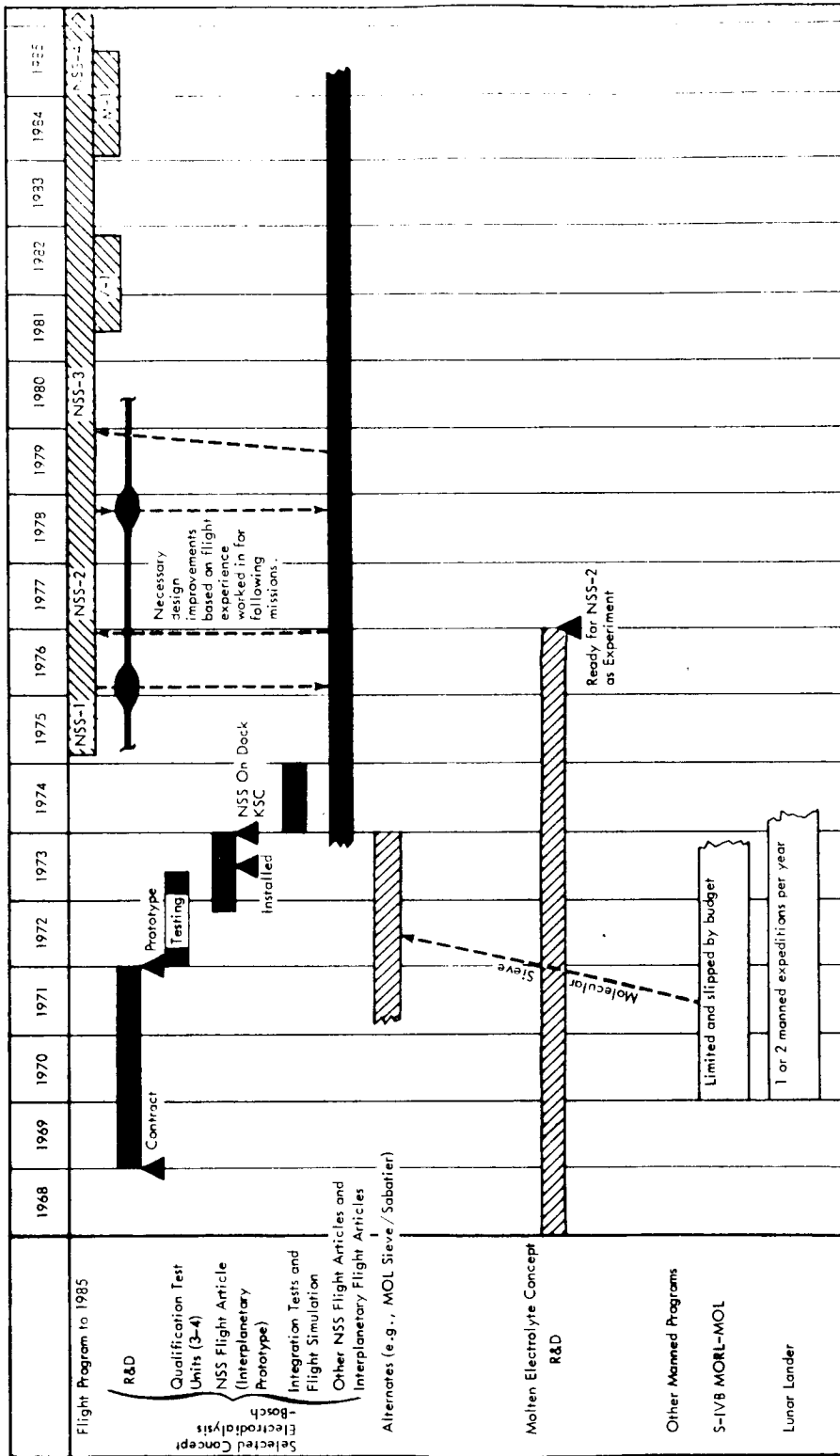

Figure 8.2-1: EVOLUTIONARY DEVELOPMENT OF THE ENVIRONMENTAL CONTROL SUBSYSTEM

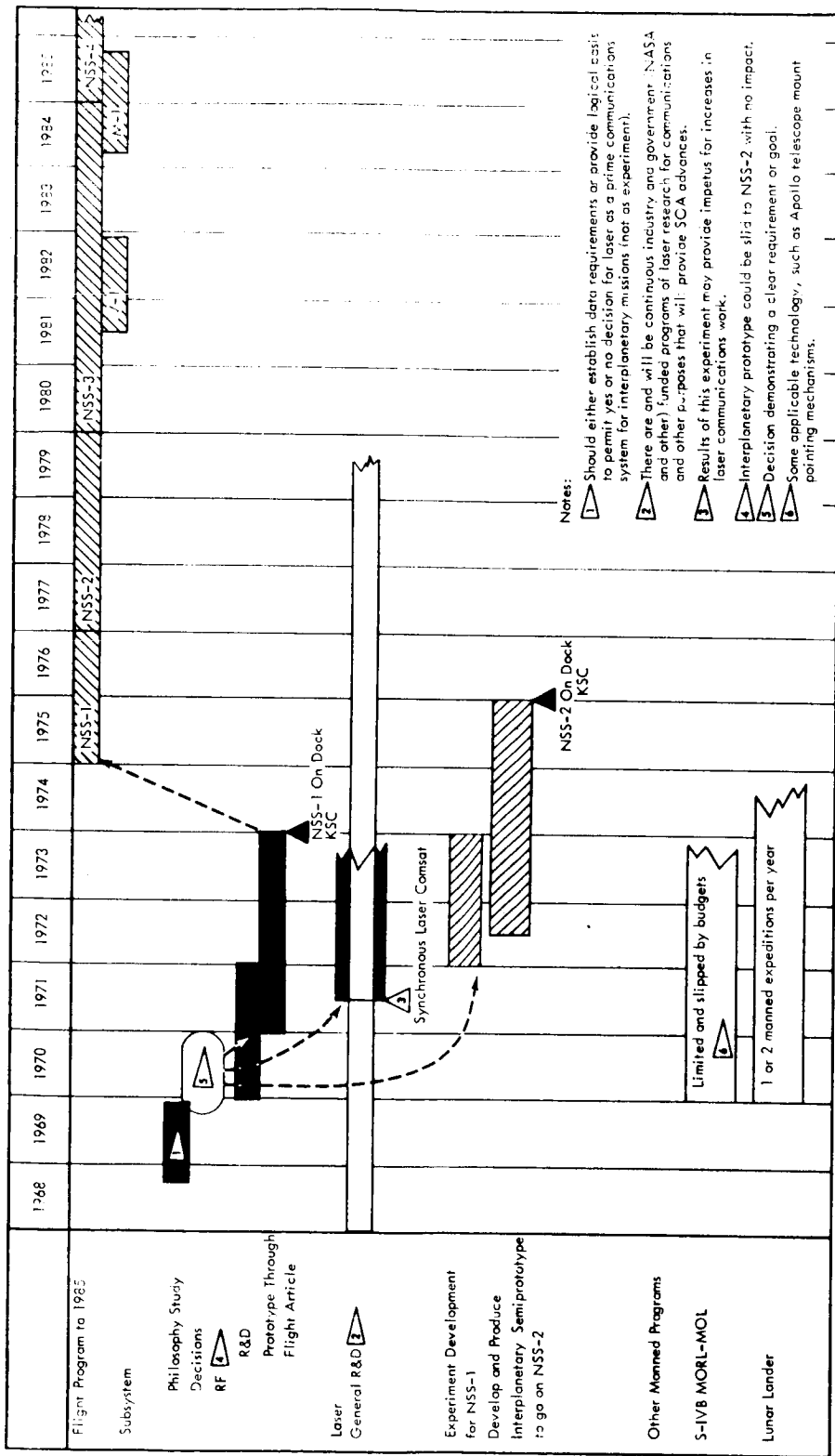

Figure 8.3-1: EVOLUTIONARY DEVELOPMENT OF THE COMMUNICATIONS SUBSYSTEM

Lasers are a new technology and have developed rapidly, but their selection for an interplanetary communications subsystem would result in a long lead time, a program technologically difficult, probably more so than for any of the other subsystems. It is definitely felt that a study should be made immediately of the total philosophy of communications with manned spacecraft, particularly manned interplanetary spacecraft. Without firm knowledge and/or decision of data rate requirements at an early date, it would not be possible to either develop or justify a laser communications system.

8.4 WATER MANAGEMENT SUBSYSTEM

Figure 8.4-1 shows an evolutionary development plan for the water management subsystem. The proposed plan is discussed in Section 7.4.1.

8.5 SPACEFLIGHT CONTROL SUBSYSTEM

The selected spaceflight control subsystem, pure reaction control jets (RCJ), does not require an extensive evolutionary development program (see Section 7.5.2.2).

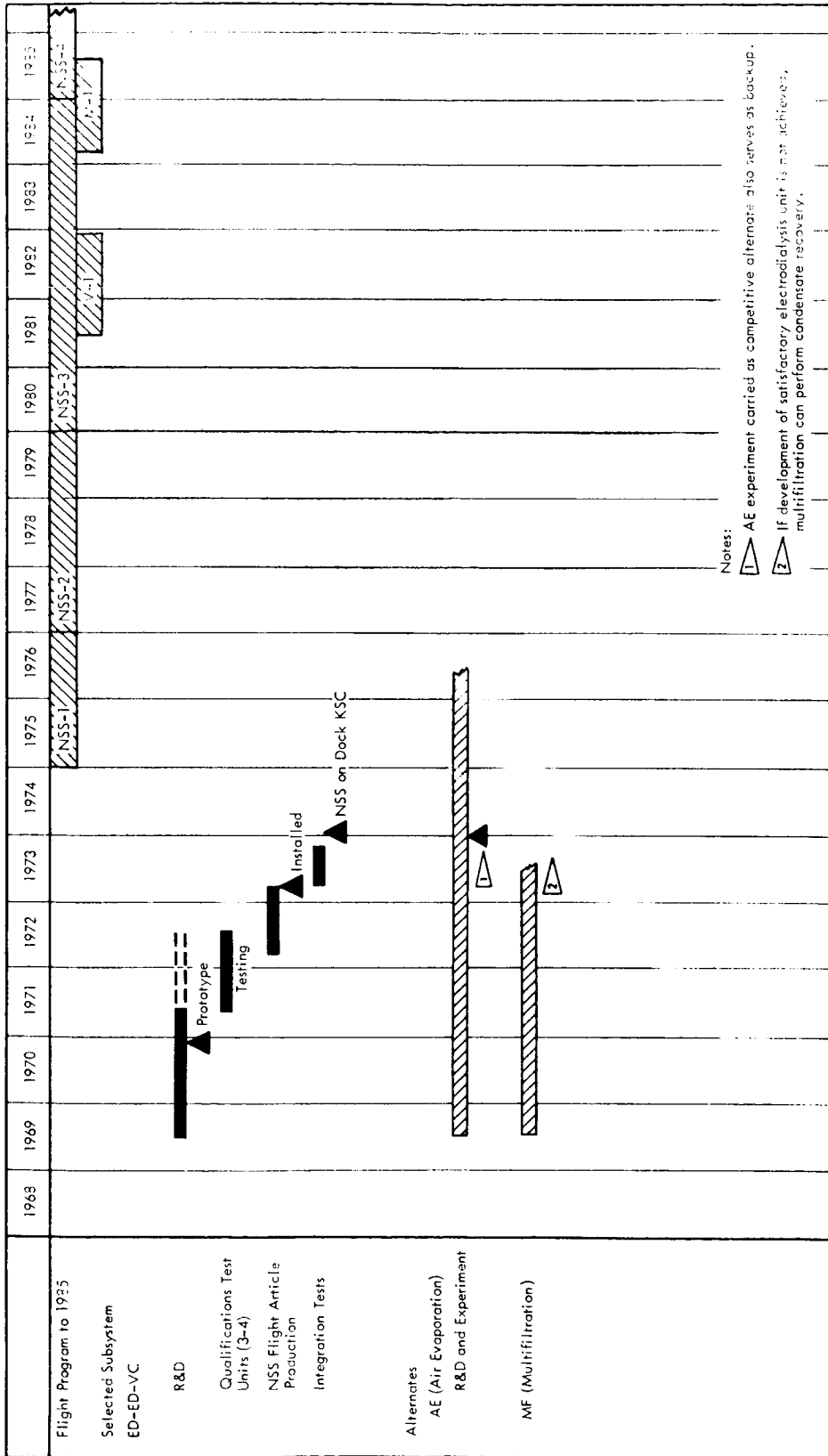

Figure 8.4-1: EVOLUTIONARY DEVELOPMENT OF THE WATER MANAGEMENT SUBSYSTEM

9.0 REFERENCES

Most of the references below are referred to in the document to indicate the source of specific bits of information. The reference source is indicated in many places (particularly in tables) by the reference number enclosed in parenthesis, for example (27). Some of the references are not referred to specifically in the text. These references were used for general, background information about a subject.

1. *Maintainability of Manned Spacecraft for Long-Duration Flights*, NASA-Ames (OART-MAD), NAS 2-3705, Boeing D2-113204-1, -2, -3, July 1967
2. *Report on Optimization of the Manned Orbital Research Laboratory (MORL) System Concept*, NASA-Langley, NAS1-3612, Douglas Reports SM-46071 through SM-46100, September 1964
3. *Subsystems Module Design Data Book*, Boeing D2-113506-1, April 1967
4. *Thermal Integration of Electric Power and Life Support Systems for Manned Space Stations*, NASA-Lewis, NAS3-6478, NASA Contractor Report CR-543, General Electric, September 1966
5. *Initial Concept of Lunar Exploration Systems for Apollo*, NAS-W-792, Boeing D2-100057-3A, 1963
6. *Design Studies of a Pu-238 Brayton Cycle Power System for the MORL Concept*, NASA Langley, NAS1-4479, Douglas, September 1966
7. *Final Report--Fabrication Feasibility Study of a 20-Watt Per Pound Solar Cell Array*, JPL Contract 951132, Boeing D2-23942-5, November 1965
8. *An Evaluation and Comparison of Power Systems for Long Duration Manned Space Vehicles*, Drisilas and Killian, Aerospace Corp., Paper for First Nonconventional Energy Conversion Applications Conference, September 1966
9. *Report on the Development of the Manned Orbital Research Laboratory (MORL) System Utilization Potential*, Final Report, NASA Langley, NAS1-3612, Douglas Report SM-48821, January 1966
10. *Electrical Power Subsystem Description and Power Requirements for Four-Man Addendum Flyby Mission, Coordination Sheet C/S 2-7741-31R1*, (Boeing) September 19, 1967
11. *Report on the Design Requirements for Reactor Power Systems for Manned Earth Orbital Applications*, NASA Langley, NAS1-5547, Douglas Report DAC-57950, January 1967
12. *Multikilowatt Solar Arrays*, NASA/JPL, NAS7-100, JPL Technical Report 32-1140, July 1967

REFERENCES (Continued)

13. *Bioastronautics Data Book*; Webb, Paul; NASA SP-3006; National Aeronautics and Space Administration, Washington D.C. (1964)
14. *Space Vehicle Water Reclamation Systems--A Status Report*; Popma, Dan C. and Collins, Vernon G.; Chemical Engineering Progress Symposium Series No. 63, Volume 62, 1966, American Institute of Chemical Engineers
15. *Earth Orbital Laboratory Environmental Control and Life Support System*; Guy, W. W.; NASA MSC, September 14, 1966
16. *Extended Mission Apollo Study of Water Reclamation, Waste Management and Personnel Hygiene*, GARD Report 1276-6070, General American Transportation Corp., November 12, 1965
17. *Water and Waste Management Subsystems for NASA Basic Subsystem Module*, Marquardt Report 25,233, 1973 EC/LSS Final Report, August 1967
18. *Report on the Optimization of the Manned Orbital Research Laboratory MORL System Concept, Volume XIV*, Douglas Report SM-46085, September 1965
19. *Life Support System for Space Flights or Extended Time Periods*, NASA CR 614, General Dynamics, November 1966
20. *Multi-Filter System for Water Reclamation*; Wallman, H., Steele, J. A. and Lubsty, J. A.; Aerospace Medicine; January 1965
21. *Water Management for Extended-Duration Manned Space Missions*; Putman, D. F.; Douglas Paper No. 4576; August 1967
22. *Chemical Aspects of Urine Distillation*; Putnam, D. F.; ASME, 65-AV-24; April 1965
23. *A Study of Water Reclamation Systems for Space Stations*; Steele, J.A.; Lubitz, J. A.; Wallman, H.; B noit, R. J.; Speziali, V. A.; Boles, T. V.; NASA Contract NAS 1-2208; NASA-Langley Research Center; Hampton, Virginia; December 1962
24. *Water Reclamation Subsystems for Space Stations*; Steele, J. A.; Lubitz, J. A.; Wallman, H.; Miner, H.; and Speziali, V. A.; NASA Contract NAS 1-2208; NASA-Langley Research Center; Hampton, Virginia; July 1963
25. *Mars Landing and Reconnaissance Mission Environmental Control and Life Support System Study*, Hamilton Standard Document SLS 414-3, pg 3-135, March 1964

REFERENCES (Continued)

26. *Water Management System Evaluation for Space Flights of One Year Duration*, General Dynamic Report 64-26206, NASA Contract NAS 1-2934, October 1963
27. *Water Reclamation Systems Study for Manned Orbital Space Vehicles*, Ionics Report, February 15, 1963
28. *The Recovery of Water from Urine by Membrane Electrodialysis*; Brown, D. L.; Sindstrom, R. W.; Smith, J. D.; AMRL-TDR-63-30; April 1963
29. *Radioisotope Heat Source IR&D Program--An Introduction to Kilowatt Isotope Power Systems for Manned Space Applications*, Atomics International, AI-65-190 Volume 6, August 1966
30. *Voyager Spacecraft System Studies, Phase B, Task D, Volume II, Mission/System Requirements and Analyses*, Marshall Space Flight Center, NAS8-22602, Boeing Document D2-115002-2, October 1967
31. *Voyager Spacecraft System Studies, Phase B, Task D, Volume III, Spacecraft Functional Description*, Marshall Space Flight Center, NAS 8-22602, Boeing Document D2-115002, 3 October 1967
32. *Electrostatically Focused Klystron Amplifiers for Deep Space Communications*, A. J. Prommer, Litton Industries, Circa 1965-66
33. *Unmanned Space Exploration Technology Strategy: A Comparison of Microwave and Laser Communications Systems for Deep Space Application*, Boeing Coordination Sheet 2-7822-30-14CS, Sandrin/Andreika to Kirchner, September 22, 1967
34. *Mariner B Configuration Data Book*, Boeing Document D2-100044-3, December 12, 1963
35. *Space Power Systems Advanced Technology Conference*, NASA-Lewis Research Center, NASA SP-131, August 1966
36. *Manned Orbiting Space Station Environmental Control and Life Support System Study*, Hamilton Standard Report SLS 410-3, May 1964
37. *Preliminary Specification for GATC Model 1230 Carbon Dioxide Remover*, General American Transportation Corporation, Mechanics Research Division
38. *Carbon Dioxide Removal and Water Electrolysis Subsystems for Manned Orbital Space Stations*, Ionics Incorporated, Report 11-P-63-48, October 21, 1963

REFERENCES (Continued)

39. *Oxygen Regeneration Test Unit for Zero Gravity Operation*, by A. D. Babinsky of Thompson Ramo Wooldridge Inc., 35th Aerospace Medical Association Meeting, May 1964
40. *Integrated Carbon Dioxide Reduction System*, TRW Electromechanical Division, Report ER-5748, January 22, 1964
41. *Oxygen Recovery System Evaluation for Space Flights of One Year Duration*, General Dynamics/Astronautics Report 64-26203, August 26, 1963; revised October 16, 1964
42. *Integrated Life Support System for the Manned Orbiting Research Laboratory for The Boeing Company*, Hamilton Standard Report SLS 319A, September 8, 1963
43. *IMISCD--Experiment Program NAS1-6774*, D2-113209-4
44. *Subsystems Module Design Data Book*, D2-113506-1
45. *Integrated Manned Interplanetary Spacecraft Concept Definition (IMISCD) Phase 1 Briefing Report*, NAS1-6774, D2-113543-1, April 18, 1967
46. *Integrated Manned Interplanetary Spacecraft Concept Definition (IMISCD) Phase 2 Briefing Report*, NAS1-6774, D2-113543-2, September 6, 1967
47. *IMISCD--Laser Communications Support*, Memo 2-7824-10-6, March 21, 1967
48. *IMISCD Communications Baseline Description*, Memo 2-7822-20-139, Feb. 28, 1967
49. *Optical and Microwave Communications--A Comparison*, F. Kalil, NASA TN D-3984, June 1967
50. *Mission/System Requirements and Analyses; Voyager Spacecraft System Studies Phase B, Task D, Volume II*, D2-115002-2
51. *Candidate Communications Subsystem for a Manned Mars Mission in 1980*, Memo 2-7822-20-124
52. "How Good are Lasers for Deep Space Communications?" *Astronautics and Aeronautics*, E. J. Reinbolt and J. L. Randall, April 1967

D2-113544-6

APPENDIX A

STUDY OF ELECTRICAL POWER SUBSYSTEMS

CONTENTS

	<u>Page</u>
A-1.0 SUBSYSTEM DEFINITION	73
A-2.0 GROUND RULES AND BASELINE REQUIREMENTS	74
A-2.1 Power Requirements	74
A-2.2 Inflight Stress	74
A-2.3 Nuclear Fuels	76
A-2.4 Reliability	77
A-3.0 ELECTRICAL POWER CONCEPTS STUDIED	78
A-4.0 METHOD OF COMPARISON	79
A-5.0 CONCEPT DESCRIPTIONS	81
A-5.1 Solar Array Subsystems	81
A-5.1.1 Description of CdS Thin-Film Arrays	85
A-5.1.2 Description of 4-Mil Solar Arrays	91
A-5.1.3 Description of 8-Mil Rollup Solar Arrays	95
A-5.2 Isotope-Powered Subsystems	99
A-5.2.1 Isotope-Brayton Cycle Electrical Power Subsystem	103
A-5.2.2 Description of the Isotope-Rankine Cycle Electrical Power Subsystem	111
A-5.3 Reactor-Powered Subsystems	111
A-5.3.1 Description of Reactor-Brayton Electrical Power Subsystem	114
A-5.3.2 Description of Reactor-Rankine Electrical Power Subsystem	114
A-5.3.3 Description of the Reactor- Thermoelectric Conversion Subsystem	114
A-5.3.4 Description of the Reactor-Thermionic Conversion Subsystem	124
A-6.0 ESTIMATED COSTS	128
A-6.1 Costing Ground Rules and Assumptions	128

A-1.0 SUBSYSTEM DEFINITION

All the electrical power subsystems described in this appendix perform the functions of generation, conversion, control, and distribution.

Power generation in the case of solar array subsystems is accomplished by the Sun. The first function performed by the solar array systems is, therefore, conversion. Because the arrays are not continuously illuminated by the Sun, electrical energy must be stored in some manner to be used during periods of eclipse. Such storage is considered to be a special case of the generation function. In the other concepts described, heat energy is generated in a nuclear reactor or by a decaying radioisotope.

Power conversion herein is the transformation of energy from one form to another (i.e., heat energy to electrical energy).

Power control includes regulation of raw power and conversion of the raw electrical power into forms (a.c. frequency and voltage and d.c. voltage) required by the spacecraft equipment.

Power distribution includes all major electrical wiring, buses, circuit breakers, switches, and monitoring devices.

A-2.0 GROUND RULES AND BASELINE REQUIREMENTS

Each subsystem described is sized to meet certain minimum performance requirements. These requirements and statements of explanation are given below.

A-2.1 POWER REQUIREMENTS

All concepts will provide a minimum of 14.22 kilowatts of useful power at the worst point in the prospective missions. Not more than 3.0 kilowatts of the required power may be provided as thermal watts. The balance of the power, 11.22 kilowatts, must be provided as electrical power. For the required power level 14.22 kilowatt was selected because it is expected that the total peak power requirements for a six-man Mars exploration mission may reach this level. A power management schedule might be used to reduce the peak demand on the system; however, this idea is not considered in the scope of this study. The requirement to provide the desired power at the worst point in the mission is based on the superior performance of the self-contained systems over solar arrays. A requirement allowing minimal performance at certain times is an advantage to solar arrays, an advantage that was felt to be unwarranted. Specifically, this requirement would apply to orbital conditions where the solar array is occulted periodically by the planet. Batteries provide the required power while occulted. During the illuminated part of the orbit, the batteries must be charged and the required power provided as well. The arrays must, therefore, be sized to do this. Table A-1 indicates major power system losses and shows the raw power necessary to provide the required useful power.

The distribution of d.c. and a.c. electrical power is assumed to be as follows: 3/1 d.c./a.c. useful power ratio; 2/1 square wave/sine wave useful power ratio.

A-2.2 INFLIGHT STRESS

All electrical power subsystems are required to withstand stresses of up to 0.1g without special attention. Again, this requirement is a constraint on the solar array concepts. It is expected that midcourse corrections and orbit trimming maneuvers may involve accelerations of 0.1g. The extremely light solar arrays that are on the drawing boards at present (Reference 7) cannot tolerate this stress. To require the folding (or rolling) up of the arrays for each maneuver is an undesirable operational requirement. Therefore the arrays must be designed for this stress level. However, arrays must also withstand the major mission accelerations--injection (V_1), planetary braking (V_2), and planetary departure (V_3). Considering these, a requirement to tolerate up to 1 + g's exists which would greatly penalize fixed solar arrays in the size required and therefore is not considered in this study.

Table A-1: LOAD AND LOSS ANALYSIS FOR VARIOUS POWER CONVERSION CONCEPTS

	Solar Arrays (watts)	Brayton Rankine (watts)	Thermo- electric (watts)	Thermionic (watts)
Useful Power				
Electrical	14,220	11,220	11,220	11,220
Thermal	---	<u>3,000</u>	<u>3,000</u>	<u>3,000</u>
Total	14,220	14,220	14,220	14,220
Losses				
Primary Voltage Regulation/Control	980(3)	540(3)	980(3)	1,045(3)
Power Control and Switching	510(3)	460*	510**	510**
Power Distribution	430(3)	390*	430**	430**
Transformer/Rectifier/ Regulator ($\eta = 90\%$)	---	1,440	---	---
Square Wave Inverter ($\eta = 90\%$)	263	205	205	205
Sine Wave Inverter ($\eta = 82\%$)	260	205	205	205
Battery Charging	8,200(3)	---	---	---
Solar Array Diodes	460(3)	---	---	---
Solar Array Drive	187	---	---	---
Radiator Pumps	---	270(3)	270(3)	---
Thermal Integration Pumps	---	<u>270</u>	<u>270</u>	<u>270</u>
Total Losses	11,290	3,780	2,870	2,665
Power Requirements Summary				
Useful Electrical Power Required	14,220	11,220	11,220	11,220
Electrical Losses	<u>11,290</u>	<u>3,780</u>	<u>2,870</u>	<u>2,665</u>
Total Electrical Power Required	25,510	15,000	14,090	13,885
Thermal Power Provided	---	<u>3,000</u>	<u>3,000</u>	<u>3,000</u>
Total Power Provided	25,510	18,000	17,090	16,885

() Indicates reference

* Estimate (10% less than solar arrays for equal weight hardware)

** Assumed the same as for solar arrays

If the solar arrays are not designed for lg stress, then for interplanetary missions they must be rolled up, folded, or otherwise supported during at least the planet departure mission acceleration. The arrays described in this section are of the rollup variety. This method was chosen because it appeared to offer the least complicated and least mass solution to the problem. Selection of this method constrains the array in width because of the length of the MM. The arrays will be stowed (rolled) in shrouds aligned with the longitudinal axis of the MM during launch from Earth's surface. The length of the MM in its launch configuration is, therefore, assumed to limit the rolled width of the array. Changes in array area due to mission requirements and to the different efficiencies of the three types of cells studied are considered as changes in the length of the unrolled array. The larger array structures must be stronger because of the increased moment arm of the longer boom. For this reason, the same specific structure mass (lb/sq ft of array) was assumed for all cell types--the lighter, less efficient, cells requiring a longer array.

A-2.3 NUCLEAR FUELS

The use of nuclear fuels to generate electrical power, instead of solar energy, is not without some problems. For one thing, they lack the inherent simplicity of solar arrays; but more important, they present a potential hazard to the crew and to Earth, and they do decline in power over several years. The power decline with time depends upon the fuel type selected. This is a significant problem in the selection of the best fuel for the isotope powered systems.

It is assumed that the reactors used in the reactor powered subsystems will provide the required power for the length of any of the planned missions (up to 5 years) without fuel replacement.

In the case of the isotope powered systems the amount of isotope specified will provide the required power for the interplanetary missions. The longer Earth orbital missions (3 and 5 years) must accept a slight decline in power toward the end of the mission or replace the fuel block. Replacement of the fuel block is not costed in any way in this study.

Nuclear materials present a hazard to the crew in flight and a potential hazard to Earth. The primary hazard to the crew is radiation. In each system using nuclear fuel, radiation to the crew is reduced to 20 REM/yr by shielding and separation. In the case of reactor systems, relatively large separation distances are required, making a boom necessary.

The hazard to Earth is primarily that of dispersion of nuclear material in the atmosphere. The most likely time that this might occur is during the return of an interplanetary mission. Unless positive action is taken, the returning MM will enter the atmosphere to burn up like a meteor, spreading nuclear materials. The worst case would be that of a Pu-238 powered system reentering the atmosphere because Pu-238 is not just a nuclear material, it is highly toxic as a chemical element. Two

alternatives are possible: inject the nuclear material into a sunward trajectory, or recover the material (intact) by some means. The best choice for the reactor systems seems to be the former. The Pu-238 isotope is so expensive that recovery is highly desirable. The exact means for either alternative is not considered in this study; however, weight is allocated for these purposes in all cases.

A-2.4 RELIABILITY

Reliability must be considered as a performance factor for each of the concepts studied. A reliability of 0.999 is assumed as a requirement that each concept must meet for each mission flown. Reliability values and the weight of spares and redundancies were found for each concept from the various references used. Scaling relationships found in Reference 1 were used to adjust the spares and redundancy weight to new values for each of the mission times used in this study (i.e., 500 days, 2 years, 3 years, and 5 years).

A-3.0 ELECTRICAL POWER CONCEPTS STUDIED

This study considers only a few of the many concepts for providing electrical power aboard a manned spacecraft. However, the few that are considered are felt to be the most likely candidates for the first generation of long-duration mission vehicles. Among the concepts not considered there are undoubtedly some that will become competitive, possibly superior, to those concepts studied here. In order to execute a program of manned orbital and interplanetary flight effectively as posed in the basic document, a selection must be made--soon--as indicated by the estimated lead times. Such concepts as regenerative fuel cells, super batteries, and magnetohydrodynamic power generation cannot at this time be considered as likely candidates for selection. Those concepts considered as candidates are discussed in some detail in Section A-5.0.

A-4.0 METHOD OF COMPARISON

The subsystem concepts described in this appendix are compared so that the most cost-effective approach may be selected. A comparison of equal performance concepts is therefore necessary. All of the concepts have been described with this in mind.

To make the cost comparison, major parameters were quantified in terms of cost. This was done according to the following equations.

$$C_T = C_{nr} + C_{rec} + C_{acc} + C_{spr}$$

where

- C_T = total cost
- C_{nr} = nonrecurring cost
- C_{rec} = recurring cost
- C_{acc} = acceleration cost
- C_{spr} = cost of spares

$$C_{nr} = C_{Te} + C_d$$

where

- C_{Te} = technology development cost
- C_d = R&D cost

$$C_{rec} = C_r (M_1 + M_2)$$

where

- C_r = unit cost of flight hardware
- M_1 = number of orbital flights
- M_2 = number of interplanetary flights

$$C_{acc} = C_4 [W_m + W_v + M_2 \times W_{s1}] + C_1 [M_1 \times W_e + W_{s2} + W_{s3} + W_{s4} + W_r \times T_{m1} + W_x (M_1 + M_2)]$$

where

- C_4 = interplanetary round-trip acceleration cost in \$/lb
- C_1 = acceleration cost to Earth orbit
- W_m = weight of hardware for Mars missions
- W_v = weight of hardware for Venus missions
- W_e = weight of hardware for Earth orbital missions
- W_{s1} = weight of spares and redundancy for interplanetary missions (500 days)
- W_{s2} = weight of spares and redundancies for 2 years
- W_{s3} = weight of spares and redundancies for 3 years
- W_{s4} = weight of spares and redundancies for two 5 year missions
- W_r = weight rate of expendables in lb/year
- T_{m1} = total number of years in Earth orbit
- W_x = miscellaneous weight (solar array launch shrouds)

$$C_{spr} = C_{sw} (W_{s1} + W_{s2} + W_{s3} + W_{s4})$$

where

- C_{sw} = cost of spares in \$/lb (unit cost/unit wt)

A-5.0 CONCEPT DESCRIPTIONS

Three types of power sources are considered: solar, isotope, and reactor. These power sources are associated with appropriate power conversion methods and discussed as electrical power subsystem concepts in Sections A-5.1, A-5.2 and A-5.3, respectively.

A-5.1 SOLAR ARRAY SUBSYSTEMS

Three types of solar cells were investigated: cadmium-sulfide thin-film cells, 8-mil silicon cells, and 4-mil silicon cells. Information pertaining to the solar cells and arrays was found in References 3, 7, 10, and 12. When necessary, specific items of information were obtained directly from specialists in appropriate technical staffs.

All arrays were assumed to be of the rollup type. This type of array was felt to be necessary to permit easy retraction before each major trajectory change on the interplanetary missions (i.e., injection, planetary capture, and planetary departure). The same type of array was specified for Earth orbital missions to save development cost of a new array and to permit qualification of the array for interplanetary flights.

With the exception of the array, batteries, and spares, all other major assemblies and components in the solar array electrical power subsystems were assumed to be the same. Arrays were sized according to the mission considering two factors, specific weight and efficiency, that vary with the cell technology. Batteries were sized to carry the full load during occultation of the Sun by the planet. Spares were determined for each mission time, Mars and Venus mission times being assumed at a single value (500 days) for determining spares. Further information on weights and the rationale for sizing and weighting arrays is provided in Table A-2 and the figures and tables associated with the paragraph.

The operation of the solar array electrical power subsystems is illustrated in Figure A-1. Structurally the array consists of two large rollout sections mounted on a telescoping boom. The boom passes through the MM and becomes the boom for the other array section. The common boom passes through an unpressurized part of the MM and is driven by a single gear motor that rotates the boom and both array sections. The boom ends are telescoped by some conventional means (hydraulic, pneumatic, or electromechanical). The arrays are unfurled by the boom during extension and rewound by "negator" springs or small gear motors during retraction of the boom. An illustration of typical arrays in deployed mode is shown by Figure A-2.

Electrically the array sections are connected to the MM by slip rings. The array sections are connected into center tapped series-parallel modules. Each array section contains three electrically independent

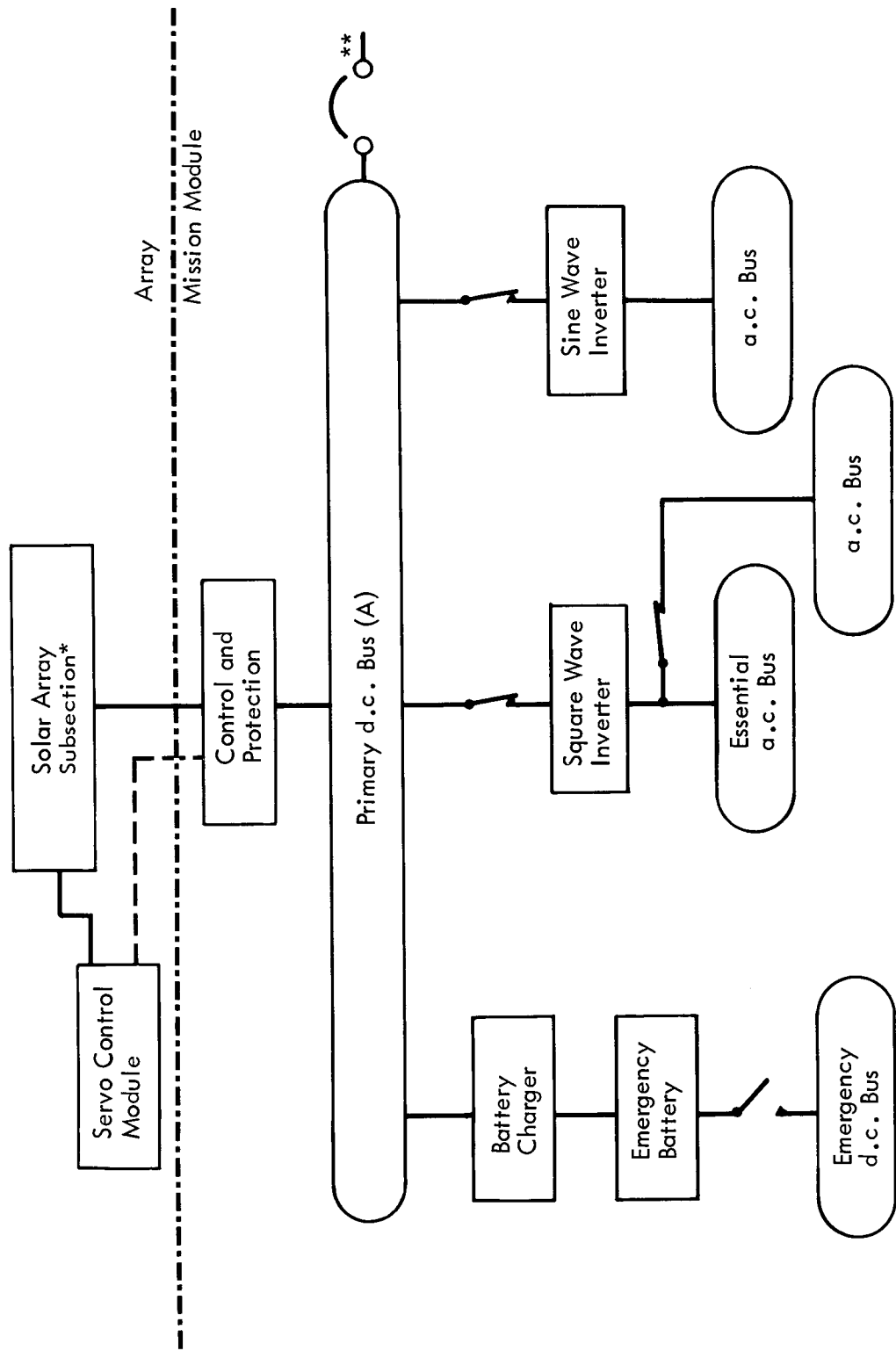

*One of several in parallel

**Cross-connection to other parallel buses

Figure A-1: TYPICAL SOLAR ARRAY POWER DISTRIBUTION

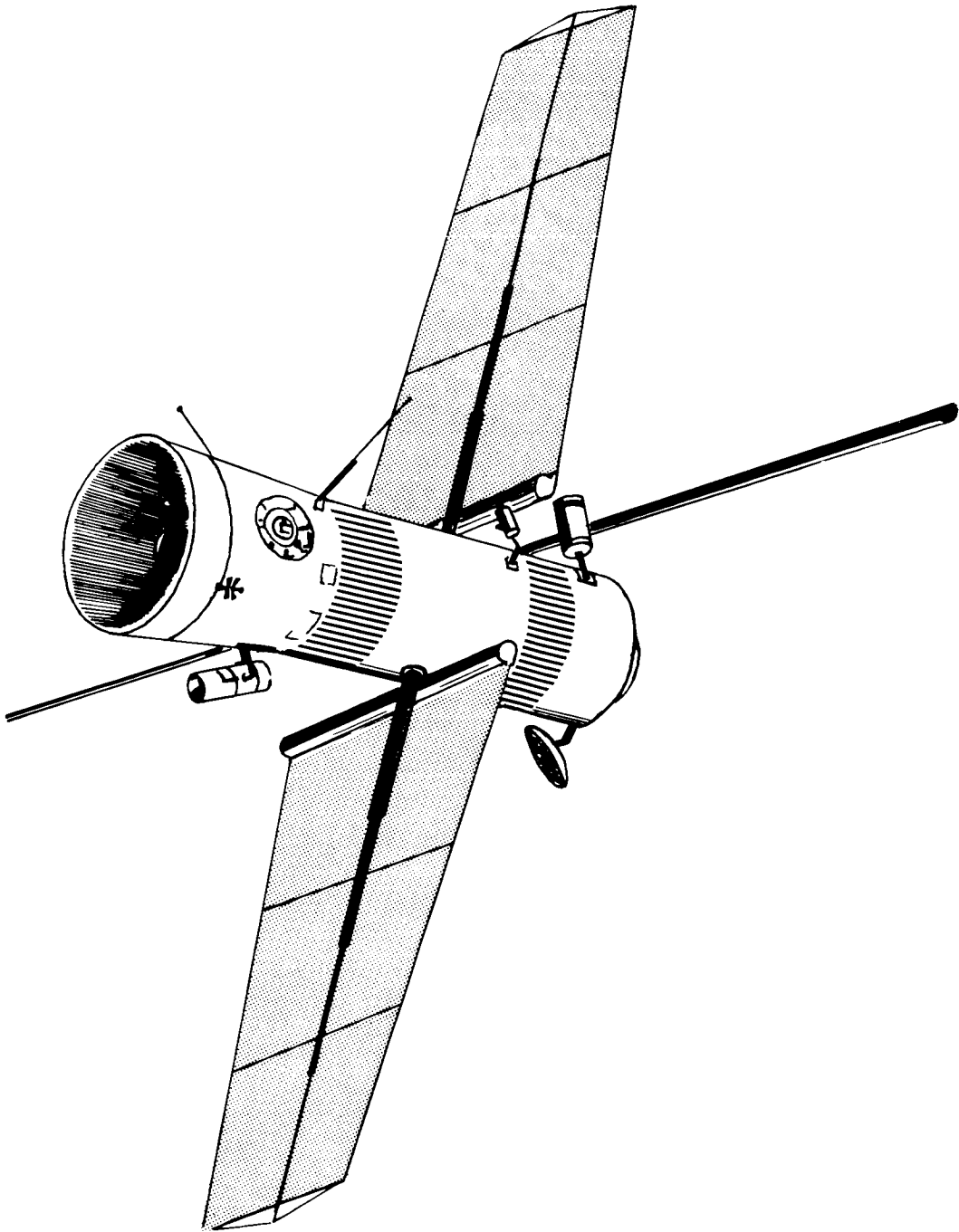

Figure A-2: TYPICAL ROLL OUT SOLAR ARRAYS

Table A-2: CONSTANTS AND ASSUMPTIONS, SOLAR ARRAYS

Power Requirements

(See Table A-1.)

Degradation

Allow for 10% degradation in final area of array.

Stress

Arrays to be designed for 0.1-g stress with rollup or foldup provisions for planned stresses over 0.1g.

Orientation

Arrays to be given one degree of freedom. Array drive rate will be variable up to 5°/min. No attitude control penalty charged.

Reliability

All electrical power subsystems will be designed for a reliability of 0.999. Maintenance and spares will contribute to reliability.

Weight (Reference 3, adjusted with References 1, 2, and 5.)

The following weights are considered constants for all solar array subsystems.

Primary voltage regulators	55	(24.95 kg) (3)
Emergency battery	50	(22.68 kg)
Inverters	93	(42.18 kg) (3)
Array gimbaling (including drive, slip rings, housing, and shaft)	60	(27.22 kg)
Power monitoring, switching and control, and distribution	846	(429.11 kg)
	<hr/>	<hr/>
Total	1,104 lb	(546.1 kg)

sections; each section contains one-third of the section modules connected in parallel. Blocking diodes prevent a failed module from drawing current from the other modules. A power transistor is connected across half of each module and is controlled by the voltage regulator. The voltage regulator senses the section voltage and controls the voltage by biasing the module transistors to shunt the module output. This method provides active voltage control with less dissipative losses than a series type regulator.

Sparing was accomplished parametrically starting with the spares weights developed in Reference 3. Weights were adjusted to the various mission lengths by parametric factors developed in Reference 1. Some weight can be saved for Earth orbital missions by minimal initial sparing and resupply of spares as required during the mission; however, this was not considered.

Solar cell stack weights are developed in Table A-3. It is entirely possible the stack weight for the CdS cell stack may be lower than that shown. Relatively little information was available on the CdS cell in comparison to the 8- and 4-mil Si cells. Therefore assumptions concerning filters, bus bars, and coatings, may be conservative.

Table A-4 shows the development of a specific weight for a 0.1g array structure. Refined design of such a large array will probably make use of cable trusses, improved boom and intercostal designs, and optimum selection of materials to reduce the array weight, resulting in weights lower than estimated in this study.

Efficiency and performance of arrays is dependent on current technology, the solar distance, and operating temperature, to mention a few factors. Efficiency and performance are measured in this study in terms of area efficiency. The values used for each type of cell and for each mission were determined from Reference 3. The pertinent curves from Reference 3 are reproduced as Figures A-3, A-4, and A-5. Figure A-3 shows the calendar current technology versus cell efficiency for the various types of cells. This figure was not used directly in the study, but is provided to show the current technology used in developing Figure A-4. Figure A-5 was used to select the design points for the various types of cells used in the array. Figure A-4 was used to size the arrays used for the Mars and Venus missions in relation to the array required for an Earth orbital mission.

A-5.1.1 DESCRIPTION OF CdS THIN-FILM ARRAYS

Requirements

Power:	25.51 kw at 1.4 A.U.
Stress:	0.1g normal to array axis (deployed)
Orientation:	360° gimbaling about array axis
Degradation:	Allow for contact deterioration and degradation due to micrometeoroids

Table A-3: SOLAR CELL STACK WEIGHTS

Materials	8-Mil Silicon		4-Mil Silicon		Cadmium-Sulfide Thin Film	
	Reference (12)	(kg/m ²)	Reference (12)	(kg/m ²)	Reference (12)	(kg/m ²)
	lb/sq ft		lb/sq ft		lb/sq ft	
Cell	0.070	(0.3417)	0.049	(0.2392)	0.062	(0.3027)
Filter or Cover Glass	0.033	(0.1612)	0.011	(0.0537)	0.001	(0.0049)
Filter or Cover Glass Adhesive	0.010	(0.0488)	NA		NA	
Bus Bars	0.024	(0.1172)	0.024	(0.1172)	0.012	(0.0586)
Dielectric	NA		NA		NA	
Interconnections	0.025	(0.1221)	0.025	(0.1221)	0.013	(0.0586)
Thermal Coatings	0.025	(0.1221)	0.025	(0.1221)	0.025	(0.1221)
Mounting Adhesive	0.010	(0.0488)	0.010	(0.0488)	NA	
Total Stack Weight	0.197	(0.9618)	0.144	(0.7030)	0.112	(0.5468)

Table A-4: ESTIMATION OF SPECIFIC WEIGHT FOR A 0.1g ARRAY STRUCTURE

Item	Stress	10^{-5} g	3×10^{-2}	0.1 g
	Reference (7)	lb/sq ft (kg/m ²)	Reference (3)* lb/sq ft (kg/m ²)	Estimate lb/sq ft (kg/m ²)
Secondary Cabling	0.0250 (0.1221)	0.0300 (0.1465)	0.0300 (0.1465)	0.0300 (0.1465)
Boom	0.0484 (0.2363)	0.0581 (0.2837)	0.0581 (0.2837)	0.2762 (1.3484)
Cross Beams	0.0098 (0.0478)	0.0118 (0.0576)	0.0118 (0.0576)	0.937 (0.4574)
Storage Drums	0.0555 (0.2710)	0.0665 (0.3247)	0.0665 (0.3247)	0.0665 (0.3247)
Array Mandrel	0.0322 (0.1572)	0.0386 (0.1884)	0.0386 (0.1884)	0.0386 (0.1884)
Rollers, Drive, etc.	0.0200 (0.0976)	0.0240 (0.1172)	0.0240 (0.1172)	0.0480 (0.2343)
Total	0.1909 (0.9320)	0.2290 (1.1180)	0.2290 (1.1180)	0.5530 (2.7000)

*Reference 3 showed 20% increase in weight from 10^{-5} g to 0.03 g. This was distributed to get the weights shown.

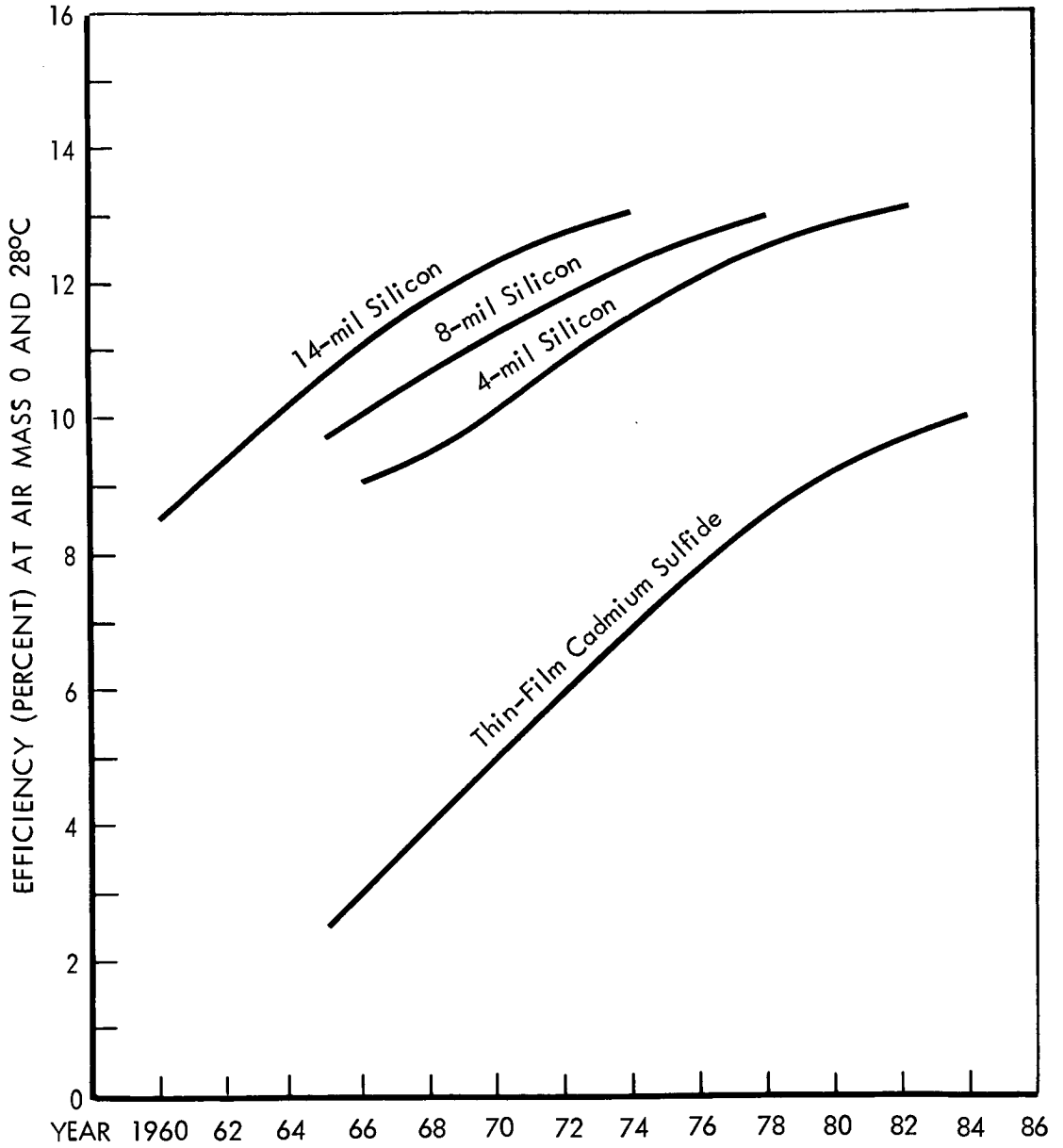

Figure A-3: ESTIMATED SOLAR CELL EFFICIENCY GROWTH TRENDS

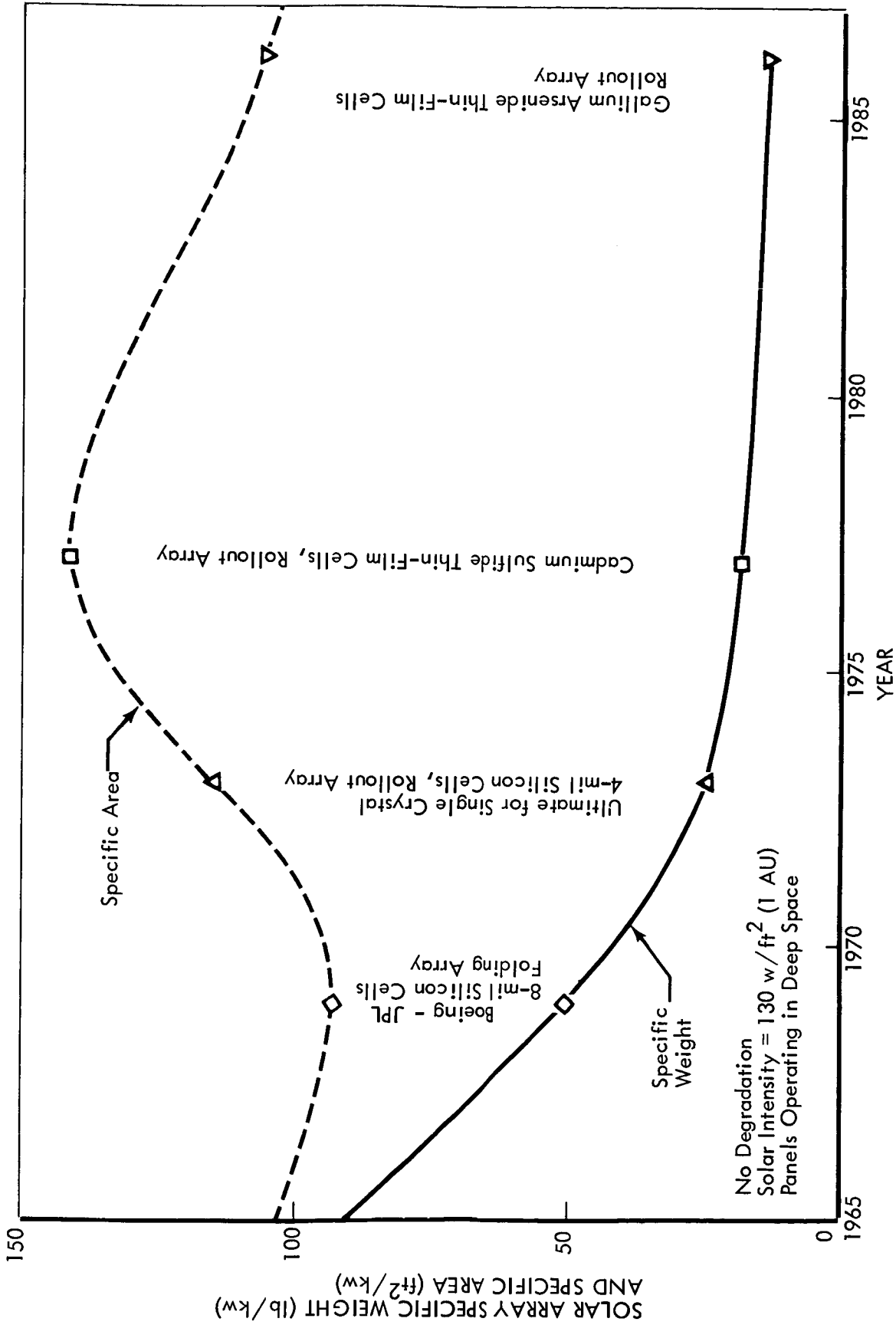

Figure A-4: ESTIMATE OF SOLAR ARRAY CURRENT TECHNOLOGY

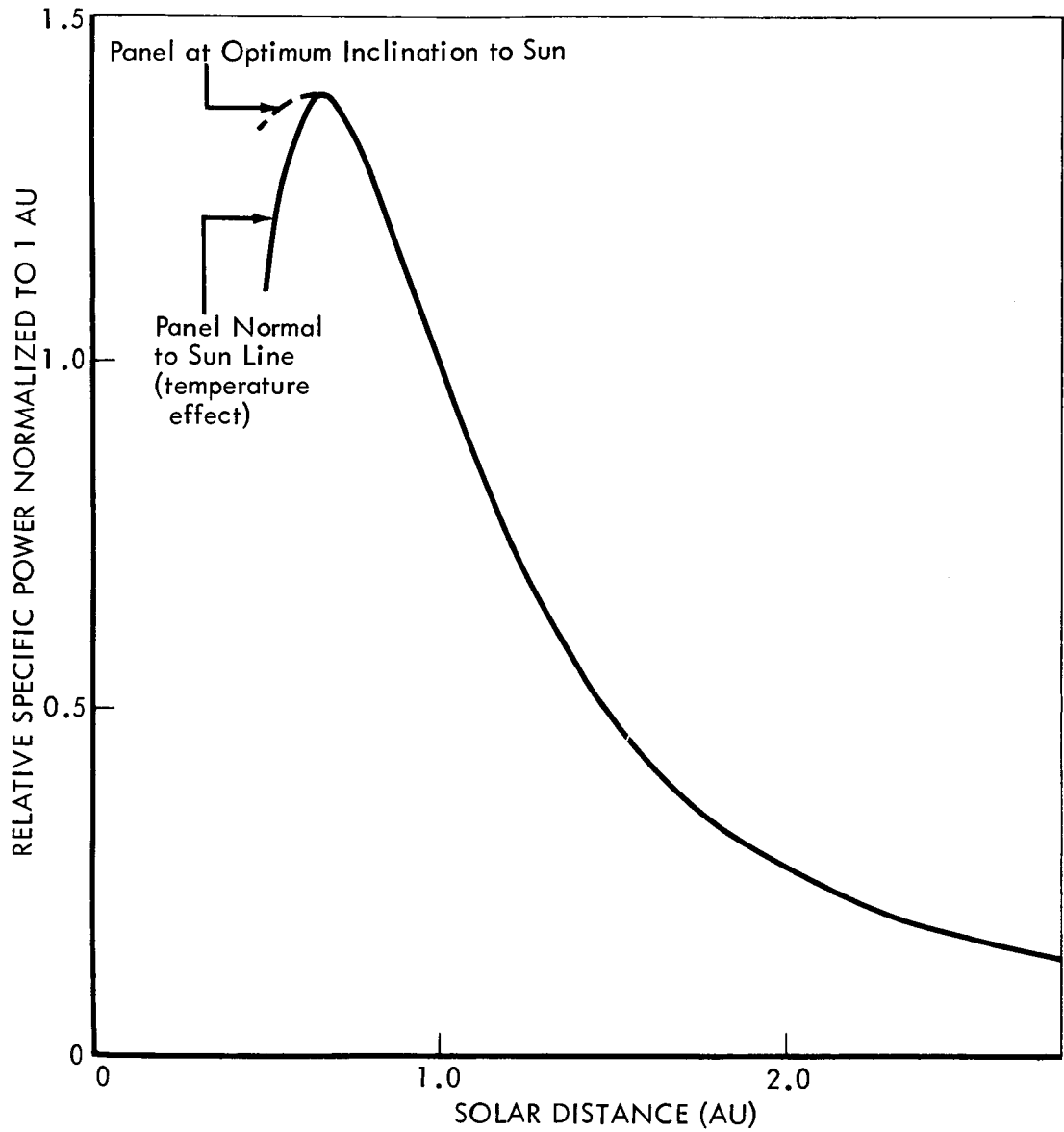

Figure A-5: PERFORMANCE OF SILICON SOLAR CELL PANELS

• Design

Concept: Rollup array

Design Point: 1977 technology (3)

Specific Power: $13.1 \text{ m}^2/\text{kw}$ ($141 \text{ ft}^2/\text{kw}$) at 1.0 A.U. undegraded--10% degradation will be assumed for all mission arrays.

At Earth the effective specific power will be $14.4 \text{ m}^2/\text{kw}$ ($155 \text{ ft}^2/\text{kw}$).

Using the inverse square law the specific power at Mars will be about $26.2 \text{ m}^2/\text{kw}$ ($282 \text{ ft}^2/\text{kw}$). The effective specific power will be $28.8 \text{ m}^2/\text{kw}$ ($310 \text{ ft}^2/\text{kw}$).

At Venus the specific power is found to be $9.48 \text{ m}^2/\text{kw}$ ($102 \text{ ft}^2/\text{kw}$), from Reference 3. And the effective specific power will be $28.8 \text{ m}^2/\text{kw}$ ($112 \text{ ft}^2/\text{kw}$).

Specific Weight: Array structure; 2.70 kg/m^2 (0.553 lb/ft^2)
 $\frac{.55 \text{ kg/m}^2}{3.25 \text{ kg/m}^2}$ ($\frac{0.112 \text{ lb/ft}^2}{.665 \text{ lb/ft}^2}$)

Design Data Sheets: Tables A-5, A-6, A-7

A-5.1.2 DESCRIPTION OF 4-MIL SOLAR ARRAYS

Power will be provided by 4-mil silicon solar cells. The subsystem schematic is similar to that provided in Figure A-1. The subsystem operation will be like that described in Section A-5.1.

Requirements

Power: 25.51 kw at 1.4 A.U.

Stress: 0.1g normal to array axis (deployed)

Orientation: 360° gimbaling about array axis

Degradation: Allow for life and micrometeoroid degradation

Design

Concept: Rollup array

Design Point: 1973 technology (3)

Specific Power: $10.7 \text{ m}^2/\text{kw}$ ($115 \text{ ft}^2/\text{kw}$) at 1.0 A.U. undegraded. For all mission arrays 10% degradation will be assumed.

At Earth the effective specific power will be $11.8 \text{ m}^2/\text{kw}$ ($127 \text{ ft}^2/\text{kw}$).

Table A-5: MARS MISSION--CdS THIN-FILM ROLLUP ARRAY

Identification/ Nomenclature	Weight (lb)	Power (kw)	Area/* Volume	Lead Time		Cost (in millions)		Remarks
				Technology	R&D	R&D**	First Article	
Array & Struct (0.1 g)	5259	25.51	7908 Sq Ft	4	3	88.8	22.205	See p 95 for specific weight & power
Fixed Weights	1104	-	-					See p. 84
Batteries	190	15.87						AgZn (3) 10.7 kwhr
Spares and Redundancies	294							For 500 days, estimated parametricly (1)
	6847					(Covers all missions)		
Launch Shroud	411							To Earth orbit only (10)

*enter area or volume if pertinent ** including flight test

Table A-6: VENUS MISSION-CdS THIN-FILM ROLLUP ARRAY

Identification Nomenclature	Weight (lb)	Power (kw)	Area/* Volume	Lead Time		R&D	Cost (in millions)		Remarks
				Technology	R&D		R&D**	First Article	
Array & Struct (0.1 g)	1900	25.51	2857 Sq Ft	5	4		13.701	See p. 95 for specific weight & power	
Fixed Weights	1104							See p. 84	
Batteries	172	15.87						9.68 kwhr	
	3176								
Spares and Redundancies	310							For 500 days, estimated parametricly (1)	
	3486								
Launch Shroud	411							To Earth orbit only (10)	

*enter area or volume if pertinent ** including flight test

Table A-7: EARTH ORBITAL MISSION (NSS)--Cds THIN-FILM ROLLUP ARRAY

Identification/ Nomenclature	Weight (lb)	Power (kw)	Area/ Volume Sq Ft	Lead Time		Cost (in millions)		Remarks
				Technology	R&D	R&D**	First Article	
Array & Struct (0.1 g)	2629	25.510	3954 Sq Ft	4	3		16.201	See p. 91 for specific weight & power
Fixed Weights	1104							See p. 84
Batteries	170	15.87						9.52 kw/hr
	3903							
Spares and Redundancies	345							2-year spares
	403							3-year spares
	1175							5-year spares
Launch Shroud	411							To Earth orbit only (10)
Expendables	170/ year							Batteries--assumed to have 1-year life

*enter area or volume if pertinent **including flight test

Using the inverse square law the specific power at Mars will be about 21.4 m²/kw (230 ft²/kw). The effective specific power will be 23.5 m²/kw (253 ft²/kw).

At Venus the specific power is found to be 7.71 m²/kw (83 ft²/kw), from Reference 3; and the effective specific power will be 8.45 m²/kw (91 ft²/kw).

Specific Weight:	Array structure: 2.70 kg/m ² (0.553 lb/ft ²)
	Solar cell stack: $\frac{0.70 \text{ kg/m}^2}{3.40 \text{ kg/m}^2}$ ($\frac{0.144 \text{ lb/ft}^2}{0.697 \text{ lb/ft}^2}$)
Design Data Sheets:	Tables A-8, A-9, A-10

A-5.1.3 DESCRIPTION OF 8-MIL ROLLUP SOLAR ARRAYS

Power is supplied during the illuminated portion of the orbit (for the NSS and for the planetary orbital period of the Mars and Venus missions) by an array of 8-mil thick silicon solar cells. Batteries, which are recharged from the solar array, supply power during occultation of the spacecraft by the planet. The subsystem schematic is similar to the schematic provided as Figure C-1. The subsystem functions in a manner similar to that described in Section C-5.1.

Requirements

Power:	25.51 kw at 1.4 A.U.
Stress:	0.1g normal to array axis (deployed)
Orientation:	360° gimbaling about array axis
Degradation:	Allow for life and micrometeoroid degradation

Design

Concept:	Rollup array
Design Point:	1969 technology (3), rollup 1973 technology
Specific Power:	8.70 m ² /kw (94 ft ² /kw) at 1.0 A.U. undegraded. For all mission arrays 10% degradation will be assumed.

At Earth the effective specific power will be 9.57 m²/kw (103 ft²/kw).

Using the inverse square law the specific power at Mars will be about 17.5 m²/kw (188 ft²/kw). The effective specific power will be 19.2 m²/kw (207 ft²/kw).

At Venus the specific power is found to be 63.2 m²/kw (68 ft²/kw), from Reference 3, and the effective specific power will be 6.97 m²/kw (75 ft²/kw).

Table A-8: MARS MISSION--4-MIL SILICON ARRAY

Identification/ Nomenclature	Weight (lb)	Power (kw)	Area/* Volume Sq Ft	Lead Time		Cost (in millions)		Remarks
				Technology	R&D	R&D**	First Article	
Array & Struct (0.1 g)	4498	25.51	6454 Sq Ft	3	2	84.8	20.505	See p. 95 for specific weight & power
Fixed Weights	1104					(See p. 84)		See p. 84
Batteries	190	15.87						AgZn (3) 10.7 kwhr
	5792							
Spares and Redundancies	294					(Covers all missions)		For 500 days, estimated parametricly (1)
	6086							
Launch Shroud	411							To Earth orbit only (10)

*enter area or volume if pertinent **including flight test

Table A-9: VENUS MISSION--4-MIL SILICON ARRAY

Identification/ Nomenclature	Weight (lb)	Power (kw)	Area/* Volume	Lead Time		Cost (in millions)		Remarks
				Technology	R&D	R&D**	First Article	
Array & Struct (0.1 g)	1618	25.51	2321 Sq Ft	4	3		12.101	See p. 95 for specific weight & power
Fixed Weights	1104							See p. 84
Batteries	172	15.87						AgZn (3) 9.68 kwhr
	2894							
Spare and Redundancies	310							For 500 days, estimated parametrically, (1)
	3204							
Launch Shroud	411							To Earth orbit only (10)

*enter area or volume if pertinent **including flight test

Table A-10: EARTH ORBITAL MISSION (NSS) --4-MIL SILICON ARRAY

Identification/ Nomenclature	Weight (lb)	Power (kw)	Area/* Volume	Lead Time		Cost (in millions)	Remarks
				Technology	R&D		
Array & Struct (0.1 g)	2258	25.51	3240 Sq Ft	3	2	14.808	See p. 94 for specific weight & power
Fixed Weight	1104						See p. 84
Batteries	170	15.87					AgZn (3) 9.52 kwhr
	3532						
Spares and Redundancies	345						2-year spares
	403						3-year spares
	1175						5-year spares
Launch Shroud	411						To Earth orbit only (10)
Expendables	170/ year						Batteries--assumed to have 1-year life

See Table A-13

*enter area or volume if pertinent **including flight test

Specific Weight: Array structure: 2.70 kg/m² (0.553 lb/ft²)
 Solar cell stack: 0.96 kg/m² (0.197 lb/ft²)
Design Data Sheets: Tables A-11, A-12, A-13

A-5.2 ISOTOPE-POWERED SUBSYSTEMS

Isotope-powered electrical power subsystems get their energy from the heat generated by the decay of an isotope of some radioactive element. Several such isotopes are feasible for use. Selection of the best isotope to use is complicated by type and intensity of the decay products that affect shield weight, the heat energy density (w/gm) of the decaying isotope which determines the amount of isotope and shield required, the half life of the isotope which affects power profile, isotope and shield weight, and the availability and cost of the isotope. Pu-238 was selected as the isotope to power both the Rankine and Brayton conversion units because of the length of the missions assumed. Availability of the isotope is considered in the lead time required to develop a flight system.

The fuel block, radiation shield, and thermal insulation are common to both conversion methods investigated with isotope power. These components differ between conversion methods in size and weight only (assumed), size and weight being related to the efficiency of the conversion cycle. The fuel block is a matrix of encapsulated isotope fuel elements, which interfaces directly with a heat exchanger containing the conversion cycle working fluid or gas. The fuel block and heat exchanger are surrounded by a 2π shield permitting the heat exchanger, which is a part of the replaceable power conversion module, to be retracted.

Two isotope-powered electrical power subsystems are considered in this study: the Brayton-cycle conversion system and the Rankine-cycle conversion system. Other types of conversion, such as thermoelectric and thermionic are not considered in this study because of the large amount of isotope required. The information about the isotope subsystems studies was derived from References 1, 2, 3, 4, 6, 8, 9, and 10. A comparison of weights for subsystem components and major assemblies as

Table A-11: MARS MISSION--8-MIL SILICON ARRAY

Identification/ Nomenclature	Weight (lb)	Power (kw)	Area/* Volume Sq Ft	Lead Time		Cost (in millions)		Remarks
				Technology	R&D	R&D**	First Article	
Array & Struct (0.1 g)	3960	25.51	5280 Sq Ft		1.5	80.8	18.805	See p. 95 for specific weight & power
Fixed Weights	1104							See p. 84
Batteries	190	15.87						AgZn (3) 10.7 kwhr
	5254							
Spares and Redundancies	294							For 500 days, estimated parametrically, (1)
	5548							
Launch Shroud	411							To Earth orbit only (10)

**including flight test

*enter area or volume if pertinent

Table A-12: VENUS MISSION--8-MIL SILICON ARRAY

Identification/ Nomenclature	Weight (lb)	Power (kw)	Area/ * Volume	Lead Time		Cost (in millions)		Remarks
				Technology	R&D	R&D**	First Article	
Array & Struct (0.1 g)	1435	25.51	1913 Sq Ft	1.0	2.5		10.801	See p. 95 for specific weight & power
Fixed Weights	1104							See p. 84
Batteries	172	15.87				AgZn (3)	9.68 kwhr	
	2711							
Spares and Redundancies	310							For 500 days, estimated parametrically, (1)
	3021							
Launch Shroud	411							To Earth orbit only (10)

*enter area or volume if pertinent **including flight test

Table A-13: EARTH ORBITAL MISSION (NSS) --8-MIL SILICON ARRAY

Identification/ Nomenclature	Weight (lb)	Power (kw)	Area/* Volume	Lead Time		Cost (in millions)		Remarks
				Technology	R&D	R&D**	First Article	
Array & Struct (0.1 g)	1971	25.51	2628 Sq Ft		1.5		13.001	See p. 95 for specific weight & power
Fixed Weights	1104							See p. 84
Batteries	170							AgZn (3) 9.52 kwhr
	3245							
Spares and Redundancies	345							2-year spares
	403							3-year spares
	1175							5-year spares
Launch Shroud	411							To Earth orbit only (10)
Expendables	170/ year							Batteries--assumed to have 1-year life

*enter area or volume if pertinent **including flight test

reported by various references is provided in Table A-14. This table was used as an aid in selecting representative weights for the isotope Brayton and the isotope Rankine subsystems. Figure A-6 shows a block schematic of the power distribution network that might be used with the Rankine-cycle and Brayton-cycle power conversion units. Rectifiers and inverters are used because of the frequency of the alternator power. The Brayton-cycle alternate is on the same shaft as the turbine and compressor and optimized design of the turbine constrains the possible frequencies of the alternator.

Table A-15 summarizes design requirements and assumptions common to the isotope-powered subsystems.

A-5.2.1 ISOTOPE BRAYTON-CYCLE ELECTRICAL POWER SUBSYSTEM

The isotope-Brayton system is composed of two independent closed Brayton-cycle power loops, with each power loop consisting of: an energy conversion subsystem; a heat rejection subsystem; and a nuclear isotope subsystem. The isotope heat source is common to both loops. The power system may be activated by the astronauts before launch or activated after injection into Earth orbit, the choice being dictated by thermal aspects of running the system during launch. The significant characteristics of the isotope-Brayton cycle may be found in Table A-16. The equipment/component list is included as Table A-17.

Prelaunch and launch thermal control of the isotopic fuel block will use a water evaporator system. During prelaunch, water will be provided through an umbilical to either an evaporator that can exchange contained heat to the fluid loop, or to a plumbed heat shield that will aid disposal of waste heat. During the launch phase, and from 4 to 10 minutes into the flight, evaporative cooling will be performed through a water system that will provide water in an open loop to either the evaporator or the heat shield during the period when the heat rejection and space radiator are ineffective. Once in orbit, heat will be controlled conventionally. In an emergency where both power conversion system (PCS) units are inoperative, waste heat can be rejected to space through a heat-dump door that will open up the face of the fuel block to space.

The power conversion system includes a combined rotating unit (CRU), a gas-to-fluid heat exchanger (also called the radiator heat exchanger), a recuperator, and a heat source heat exchanger. The PCS is packaged as a replaceable unit.

The CRU is the heart of each replaceable PCS package. It consists of a high-frequency permanent magnet alternator, a single-stage centrifugal compressor and a single-stage radial inward flow turbine. These components are mounted on a common shaft. The turbine and compressor are located outboard from two bearings, hydrodynamic gas or foil, with the alternator straddle-mounted between the bearings. The CRU operates at a controlled rotational speed of 64,000 rpm. The alternator generates high-frequency a.c. power at 1067 cps. Brayton-cycle generation is started by using the emergency battery for power to motorize the

Table A-14: WEIGHT ESTIMATES, BY REFERENCE, SCALED LINEARLY TO 15.0 kw

Equipment List	Weight (lb)								
	Reference (1)	Reference (1)	Reference (3)	Reference (4)	Reference (6)	Reference (8)	Reference (9)		
Fuel Block & Shield	2430	3885	2840	5118	2254	3000			
Fuel block	(352)	(1482)				(1500)			
Shield	(2078)	(2403)	(1990)			(1500)			
Thermal shield			(850)						
Evaporator	177	---	190	---	177				
Brayton Cycle Modules	1475	2503	1140	1936	1533	1800			
Power/Speed Control	150	110	270	285	305				
Controller/sensor	(14)	(10)	(110)						
Parasitic Load	(136)	(100)	(160)						
Radiator Loop	190	158	880	880	448	563			
Radiator	(127)	(108)	(770)	(848)	(325)				
Pump/motor units	(63)	(50)	(110)		(123)				
Thermal Integration	41	30	50	8	87				
Structure	120	88	800	1010	1471	668			
Heat Rejection	46	---	---	---	---	---	---		
	4629	6774	6170	8277	6275	6031	5430		
Power Control	432	556	445		320				
Trans/rect/reg units	(136)	(205)	(205)						
Inverters	(247)	(247)	(75)						
Monitor/control/switching	(49)	(104)	(180)						
Power Distribution	1156	1003	300						
Other	760	55	---		200	803			
	2348	1614	745		520	803	1485		
Total	6977	8388	6915	8277	6795	6834	6915		

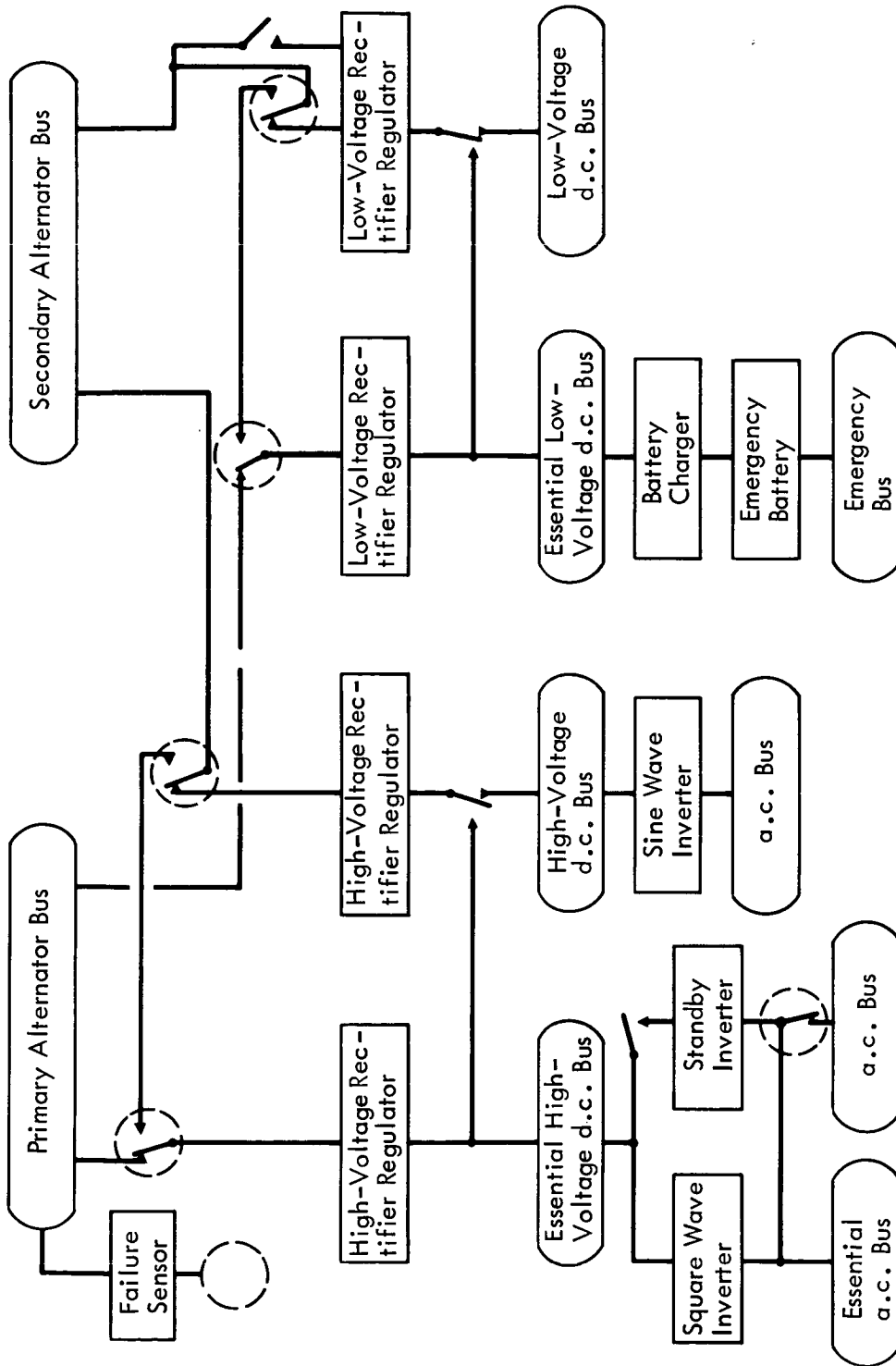

Figure A-6: TYPICAL POWER DISTRIBUTION SYSTEM

Table A-15: CONSTANTS AND ASSUMPTIONS, ISOTOPE ELECTRICAL POWER SUBSYSTEMS

Power Requirements

14,220 watts useful power (excluding electrical power system losses)

Degradation

To be included in the mass of isotope fuel carried

Stress

All designs stressed for Earth launch accelerations

Orientation

Orientation not required for isotope systems

Reliability

All electrical power subsystems will be designed for a reliability of 0.999. Maintenance and spares will contribute to reliability.

Weight

The following weights are considered constants for all isotope subsystems:

Alternator controllers	110 lb	(49.9 kg) (3,4)*
Inverters (square wave)	50	(22.7 kg) (5)
(sine wave)	25	(11.3 kg) (5)
Transformer/rectifier/ regulators	205	(93.0 kg) (3)
Thermal integration (including pump)	50	(22.7 kg) (3)
Power conditioning and switching and distribution	846	(383.7 kg) (1)
Emergency battery	50	(22.7 kg)
Radiator pumps	50	(22.7 kg) (3,6)
Parasitic loads	160	(72.6 kg) (4)
Total	1,536 lb	(696.7 kg)

d.c./a.c. Loads: 3/1 d.c./a.c. useful power ratio
2/1 square wave/sine wave useful power ratio

*Reference numbers

Table A-16: Pu-238/BRAYTON SUBSYSTEM CHARACTERISTICS

Heat Source	
Thermal power: Beginning of life	71.5 kw _t
End of life	71.0 kw _t
Fuel block surface temperature, operating maximum	1800°F
Fuel block--heat exchanger temperature differential, nominal (gas outlet end)	110°F
Power Conversion Module	
Working fluid	Argon or Helium-Xenon
Turbine inlet temperature	1640°F
Heat-source heat exchanger, inlet temperature	1203°F
Compressor inlet temperature	65°F to 115°F
Shaft speed	64,000 rpm
Recuperator effectiveness	0.92
Compressor pressure ratio	1.95
Compressor efficiency	0.80
Turbine pressure ratio	1.716
Turbine efficiency	0.873
Type of alternator	Rice
Frequency (cps)	1067
Overall cycle efficiency	22%
Radiator	
Area	1430 square feet
Number of loops	6
Coolant fluid	FC-75
Inlet temperature	266°F
Outlet temperature	51°F
Absorptivity/emissivity (maximum)	0.25

Table A-17: Pu-238 ISOTOPE BRAYTON

Identification/ Nomenclature	Weight (lb)	Power (kw)	Area/* Volume	Lead Time		Cost (in millions)		Remarks
				Technology	R&D	R&D**	First Article	
Fuel Block and Shield	2840	71.5		4	7	101.4	4.9†	7 years lead time for fuel
Evaporator	190							
Brayton Cycle Modules	1140	15.0						
Power/Speed Control	270							
Radiator Loop	880							
Thermal Integ	50							
Structures	800							
Heat Rejection	46							
Transformer/ Rectifier Units	205							
Inverters	75							
Monitor, Control Switching & Dist	846							Same for all concepts
Emergency Battery	150							
	7492							
Spares and Redundancies	1353							For 500 days; estimated from (1)

*enter area or volume if pertinent **including flight test †Not including fuel

alternator through the use of the standby inverter. The CRU is motored up to a speed where self-sustaining operation is possible. Shutdown is accomplished by closing an argon gas shutoff valve at the outlet of the compressor.

The heat source heat exchanger is a thin plate, probably of TD nickel, into which the working gas (argon) flows. The plate is in close conjunction to one face of the isotopic heat source block. Argon gas passes through the heat exchanger, absorbing heat from the fuel block, and passing directly to the CRU.

The high efficiency of the Brayton cycle is possible through the use of a recuperator. Waste thermal energy is transferred from the turbine exhaust to the compressor discharge gas, thereby retaining this energy in the cycle. This is shown in the Brayton cycle diagram, Figure A-7.

The nuclear isotope subsystem interfaces with the PCS through the argon heat source heat exchanger. The fuel block is a single complex block containing approximately 71.5 thermal kilowatts of Pu-238. One side of the block services the "A" PCS and the opposite side of the block services the "B" PCS. The block is shielded by lithium hydride, thermal insulation, and reflective thermal coatings. One side of the block is exposed to space through one of the argon heat source heat exchangers and a heat dump door. In the emergency state where both PCS's are inoperative, heat can be dumped from the isotope fuel source by opening the heat dump door, as previously explained.

Power is supplied from each PCS alternator to a magnetic amplifier that is linked to a CRU speed sensor. Speed of the CRU is maintained through control of the electrical load. The magnetic amplifier shunts power on demand to the spacecraft systems and dumps excess electrical energy into a parasitic load resistor, which radiates this heat to space. Each power system supplies alternator power to its own alternator bus, and thence to two main loads: the low voltage d.c. rectifier regulator and the high-voltage rectifier and regulator.

The PCS heat sink heat exchanger is provided with a heat exchange loop, connected to the environmental and life support systems, which transfers residual heat from the argon gas loop to a heat transfer fluid. Additional heat energy must be provided to this fluid to raise its temperature to 182°C (360°F) as required by the environmental control life support subsystem heat load. It is expected that with both PCS units operating, approximately 4 thermal kilowatts can be provided to the environmental control life support subsystem in this manner. Additional heat energy can be provided to the 168°C water by plumbing the radiation shield and picking up the differential temperature directly from the fuel block heat.

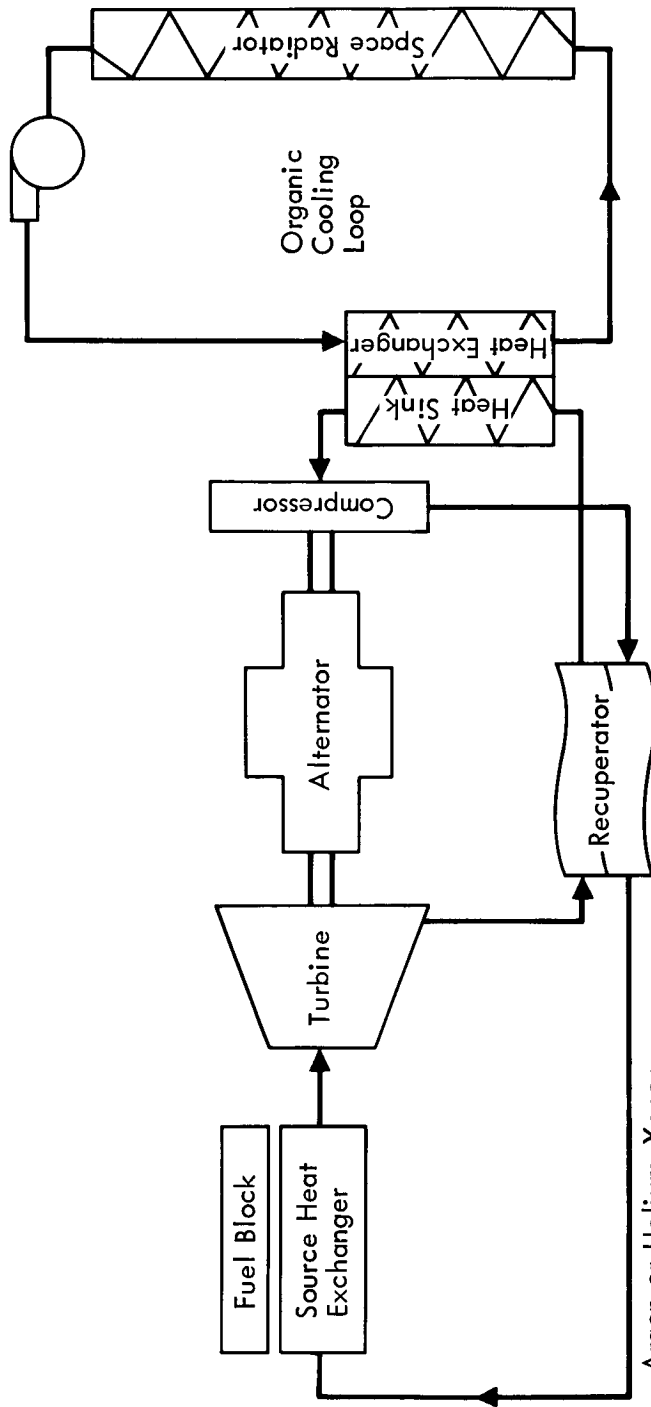

Figure A-7: ISOTOPE-BRAYTON POWER CONVERSION SYSTEM

Argon or Helium-Xenon

A-5.2.2 DESCRIPTION OF THE ISOTOPE-RANKINE ELECTRICAL POWER SUBSYSTEM

The isotope-Rankine subsystem is similar to the isotope-Brayton subsystem. The primary difference is in the working fluid loop, in which the Rankine working fluid (Hg) must pass through two phase changes, liquid to vapor and vapor to liquid. The source heat exchanger of the Brayton system is replaced with a Mercury boiler in the Rankine system. Also, the heat-sink heat exchanger is replaced with a condenser-heat exchanger. A secondary radiator cooling loop is used (like the Brayton) to avoid condensing the Hg in the radiator and to avoid inter-related vehicle/power system design, thus complicating the design. All other features of the two conversion systems are assumed identical. Figure A-8 shows a schematic of a typical Rankine conversion cycle.

Table A-18 presents the significant characteristics of the isotope-Rankine electrical power concept. An equipment/component list of the Rankine system is presented as Table A-19.

Table A-18: Pu-238/RANKINE SUBSYSTEM CHARACTERISTICS

Heat Source

Thermal power	200 kw _t
Fuel block surface temperature maximum operating	1,350°F
Fuel block-heat exchanger temp differential	160°F

Power Conversion Module

Boiler inlet temperature	205°F
Boiler outlet temperature	1,185°F
Turbine inlet temperature	1,150°F
Turbine outlet temperature	630°F
Turbine speed	36,000 rpm
Turbine efficiency	55%
Alternator output	5.0 kw
Alternator efficiency	90%
Overall efficiency (end of life)	7.85%

Radiator Condenser

Area	432 ft ²
Inlet temperature	630°F
Outlet temperature	352°F

A-5.3 REACTOR-POWERED SUBSYSTEMS

Four conversion methods are described in relation to nuclear reactors as thermal power sources. These methods are thermoelectric conversion, thermionic conversion, Brayton-cycle, and Rankine-cycle conversion. The Brayton and Rankine cycle machinery is almost identical to that described for the isotope-powered concepts. With a reactor, however, heat must be transferred to the Rankine and Brayton units by an intermediate heat transfer fluid, eutectic NaK.

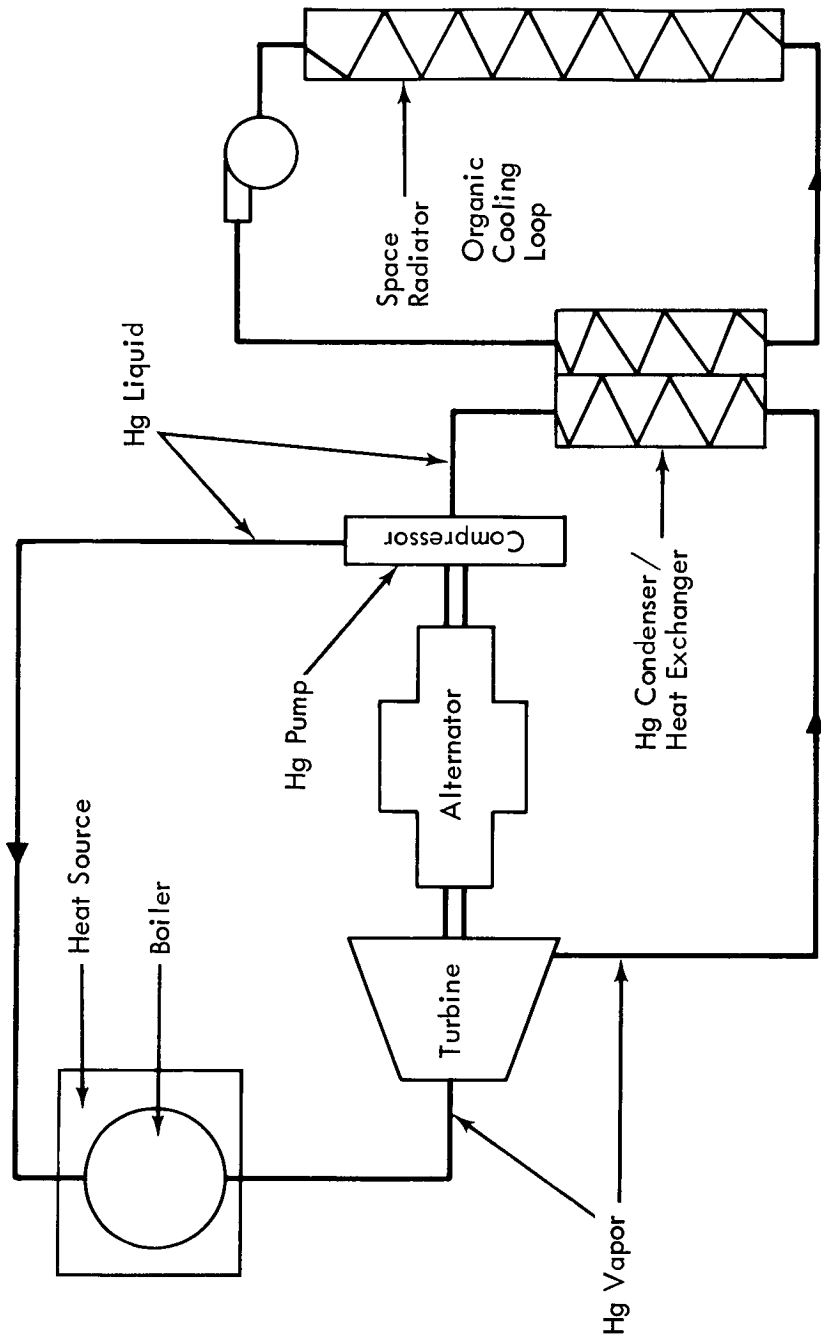

Figure A-8: TYPICAL ISOTOPE-RANKINE CYCLE CONVERSION SUBSYSTEM

Table A-19: Pu-238 ISOTOPE RANKINE

Identification/ Nomenclature	Weight (lb)	Power (kw)	Area/ * Volume	Lead Time		Cost (in millions)		Remarks
				Technology	R&D	R&D**	First Article	
Fuel Block and Shield	4680	200.0		3	7	96.4	4.4†	7 years lead time for fuel
Evaporator	380							
Bankine Cycle Modules	1025	15.0						
Power/Speed Control	270							
Radiator/ Condensers	490							
Thermal Integ.	50							
Structures	800							Assumed the same as isotope-Brayton
Heat Rejection	46							
Transformer/ Rectifier Units	205							
Inverters (2)	75							
Monitor, Control Switching & Dist	846							Same for all concepts
Emergency Battery	150							
	9017							
Spares and Redundancies	1463							For 500 days, estimated from (1)

*enter area or volume if pertinent **including flight test †Not including fuel

For the thermoelectric, Brayton and Rankine concepts, reactor design is based on the SNAP-8 reactor technology. The reactor assembly consists of core and reflector. The core subassembly includes a core vessel, grid plates, baffle plate, internal reflectors, and fuel elements. Attached to the outside of the core vessel are supports that hold the reflector subassembly. The reflector subassembly includes eight rotatable Beryllium control drums that are tapered to reduce the shadow cone envelope. Reactor power is controlled by rotation of the control drums. Reactor shutdown is accomplished by rotating the control drums to their least reactive position.

The reactor is thermally coupled to the conversion systems by a primary coolant loop that circulates a eutectic mixture of sodium and potassium (NaK). Primary loop circulation is accomplished by thermoelectric magnetic pumps similar to those used in the SNAP-10A system.

Shielding of the reactor is accomplished by two depleted uranium alloy gamma shields and two natural lithium hydride shields. All shields are of the shadow type. To improve the effectiveness of the shields, the entire reactor assembly is mounted on a boom to provide a reactor-vehicle separation distance of approximately 125 feet (38 meters). Figure A-9 provides a typical view of the reactor assembly.

A-5.3.1 DESCRIPTION OF REACTOR-BRAYTON ELECTRICAL POWER SUBSYSTEM.

The reactor-Brayton electrical power subsystem is a combination of the Brayton-cycle conversion system discussed in Section A-5.3. The ancillary power distribution and conditioning system will be the same as illustrated in Figure A-6.

Table A-20 provides a summary of the characteristics of the reactor-Brayton cycle concept. An equipment component list for this concept is provided in Table A-21.

A-5.3.2 DESCRIPTION OF REACTOR-RANKINE ELECTRICAL POWER SUBSYSTEM

The reactor-Rankine electrical power subsystem is a combination of the reactor discussed in Section A-5.3 and the Rankine conversion system discussed in Section A-5.2.2. Figure A-6 illustrates the typical electrical power distribution and conditioning systems that will interface with the Rankine conversion units. The characteristics of the concept are provided in Table A-22. Table A-23 provides an equipment component list.

A-5.3.3 DESCRIPTION OF THE REACTOR/THERMOELECTRIC CONVERSION SUBSYSTEM

The thermoelectric converter produces direct-current (d.c.) electricity by direct conversion of heat energy. The heat is applied to one of two dissimilar semiconductor materials. The other semiconductor is cooled by direct radiation to space or by a cooling fluid that rejects heat to space through a radiator. The resulting temperature gradient across the

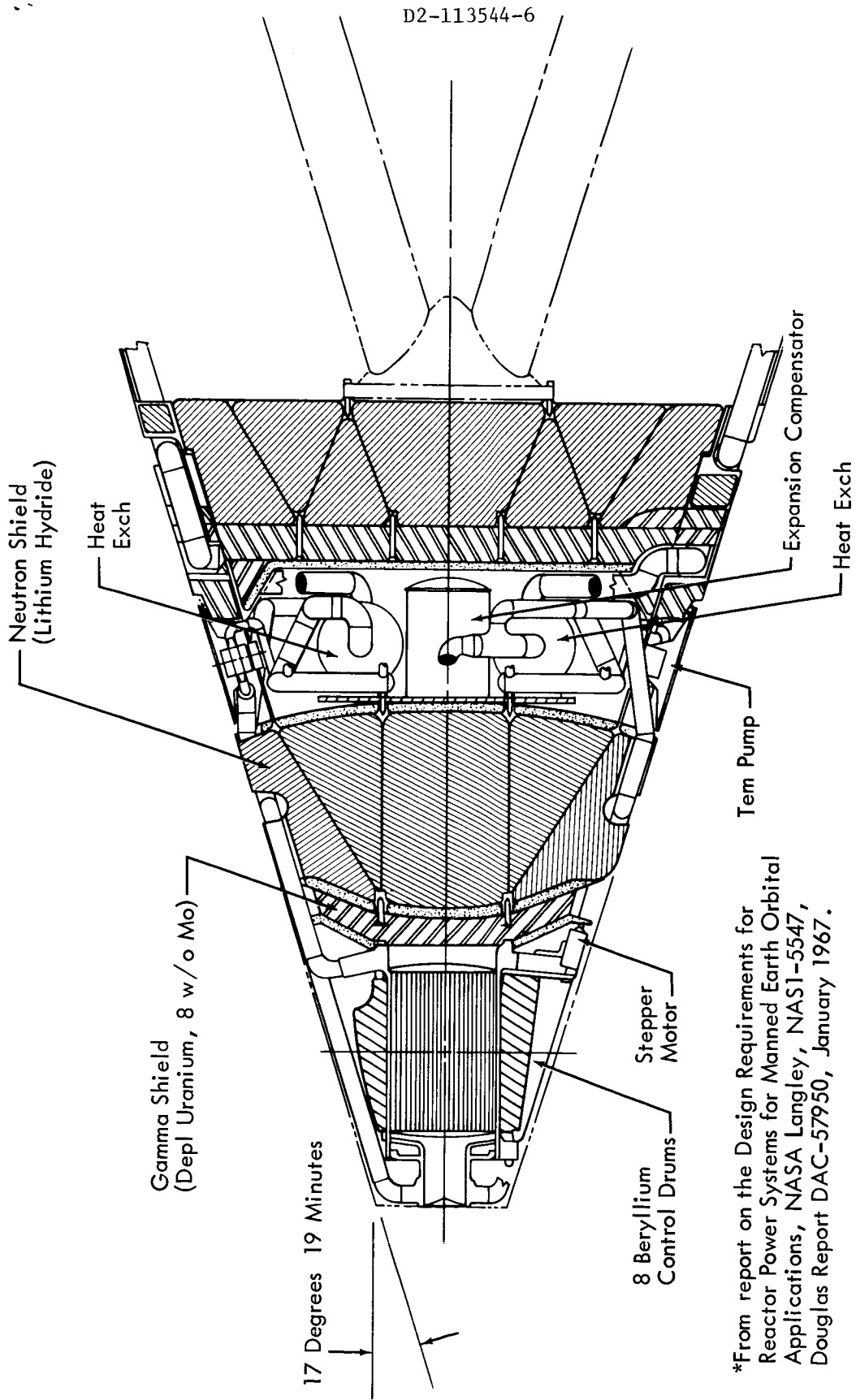

*From report on the Design Requirements for Reactor Power Systems for Manned Earth Orbital Applications, NASA Langley, NAS1-5547, Douglas Report DAC-57950, January 1967.

Figure A-9: TYPICAL REACTOR FOR BRAYTON OR RANKINE CYCLE CONVERSION

junction of the dissimilar semiconductors produces a potential difference. The concept is similar to that employed in thermocouple temperature sensors, which use dissimilar metals rather than semiconductors. Semiconductor materials are used in thermoelectric conversion to improve conversion efficiency and to reduce heat losses across the junction of dissimilar materials. In the reactor-thermoelectric conversion concept heat is provided by a nuclear reactor, assumed in this study to be a modified SNAP-8 reactor.

Several small (3 to 25 watts) thermoelectric conversion systems have been flown in unmanned satellites. The largest thermoelectric system flown to date was the SNAP-10A 500-watt, which flew for 43 days. The same SNAP-10A has been subjected to a ground run of one year. The characteristics of the reactor/thermoelectric conversion subsystem are summarized in Table A-24. Figure A-10 shows a diagram of the reactor/thermoelectric conversion used in this study. The electrical power from the converter will be distributed in a conventional manner as shown in Figure A-11. A flight model would probably use a converter separated into several units each supplying power to a separate bus. The subsystem equipment/component list is shown in Table A-25.

Table A-20: REACTOR-BRAYTON SUBSYSTEM CHARACTERISTICS

Reactor

Type	Modified SNAP-8
Reactor thermal power	71.5 kw
Outlet temperature	1800°F
Rated life	3 years
Primary loop coolant	NaK-78
Reflector material	Beryllium
Number of active control drums	8
Envelope diameter at reactor core midplane	24.7 inches

Shield

Gamma shield material	Depleted U-8% Mo
Neutron shield material	Natural Lithium Hydride
Neutron shield containment material	Type 347 SS
Reactor-vehicle separation distance	125 feet
Dose plane diameter	80 feet
Dose rate	20 REM/yr

Power Conversion Module (see Section A-5.2.1)

Radiator (see Section A-5.2.1)

Table A-21: REACTOR-BRAYTON

Identification/ Nomenclature	Weight (lb)	Power (kw)	Area/ * Volume	Lead Time		Cost (in millions)		Remarks
				Technology	R&D	R&D**	First Article	
Reactor and Shield	7850	71.5		3	3.5	138.6	8.6	
Boom and Cable	1990							
Reactor Disposal System	510							
NaK Loop	160							
Brayton Cycle Modules	1230	15.0						
Power-Speed Control	270							
Radiator Loop	870							
Thermal Int.	50							
Structures	975							
Heat Rejection	46							
Transformer- Rectifier Units	205							
Inverters	75							
Monitor, Control Switching & Dist	846							Same for all concepts
Emer. Battery	150							
	<u>12,727</u>							
Spares and Redundancies	1,353							For 500 days, estimated from (1)

*enter area or volume if pertinent **including flight test

Table A-22: REACTOR-RANKINE SUBSYSTEM CHARACTERISTICS

Reactor		
Type		Modified SNAP-8
Reactor thermal power		191 kw
Outlet temperature		1300°F
Rated life		3 years
Primary loop coolant		NaK-78
Reflector material		Beryllium
Number of active control drums		8
Envelope diameter at reactor core midplane		24.7 inches
Shield		
Gamma shield material		Depleted U-8% Mo
Neutron shield material		Natural Lithium Hydride
Neutron shield containment material		Type 347 SS
Reactor vehicle separation distance		125 feet
Dose plane diameter		80 feet
Dose rate		20 REM/Yr.
Power Conversion Module		
Boiler:	Inlet temperature	205°F
	Outlet temperature	1185°F
Turbine:	Inlet temperature	1150°F
	Exhaust temperature	630°F
	Speed	36,000 rpm
	Efficiency	55%
Alternator:	Output	5.0 kwe each (3)
	Efficiency	90%
Radiator-Condenser		
Area		432 square feet
Average condensing temperature		610°F
Outlet temperature		352°F
Overall efficiency (end of life)		7.85%

Table A-23: REACTOR-RANKINE

Identification/ Nomenclature	Weight (lb)	Power (kw)	Area/ Volume*	Lead Time		R&D	Cost (in millions)		Remarks
				Technology	R&D		R&D**	First Article	
Reactor and Shield	8325	200		1.5	3.5	128.1	8.9	200 kw _t	
Boom and Cable	2100								
Disposal System	510								
NaK Loop	355								
Rankine Cycle Modules	1025	15.0							
Power-Speed Control	270								
Radiator- Condensers	490								
Thermal Int	50								
Structures	975							Assumed the same as Reactor-Brayton system	
Heat Rejection	46								
Transformer- Rectifier Units	205								
Inverters	75								
Monitor, Control Switching & Dist	846							Same for all concepts	
Emer. Battery	150								
	<u>15,422</u>								
Spares and Redundancies	1,463							For 500 days, estimated from (1)	

*enter area or volume if pertinent **including flight test

Table A-24: REACTOR-THERMOELECTRIC SiGe SUBSYSTEM CHARACTERISTICS

Reactor

Type	Modified SNAP-8
Reactor thermal power	607 kw _t
Outlet temperature	1300°F
Rated life	3 yrs.
Primary loop coolant	NaK - 78
Reflector material	Beryllium
Number of active control drums	8
Envelope diameter at reactor core midplane	24.7 inches

Shield

Gamma shield material	Depleted U-8% Mo
Neutron shield material	Natural Lithium Hydride
Neutron shield containment material	Type 347 SS
Reactor-vehicle separation distance	125 feet
Dose plane diameter	80 feet
Dose rate at vehicle	20 REM/Yr.

Power Conversion Module

Hot junction temperature (average)	1150°F
Cold junction temperature (average)	550°F
Overall efficiency - end of life	2.32%
Output	14,090 kwe
Number of active loops	6
Number of standby loops	1
Number of connectors per loop	2

Radiator

Area	1450 ft ²
Inlet temperature	650°F
Outlet temperature	450°F
Coolant fluid	NaK - 78

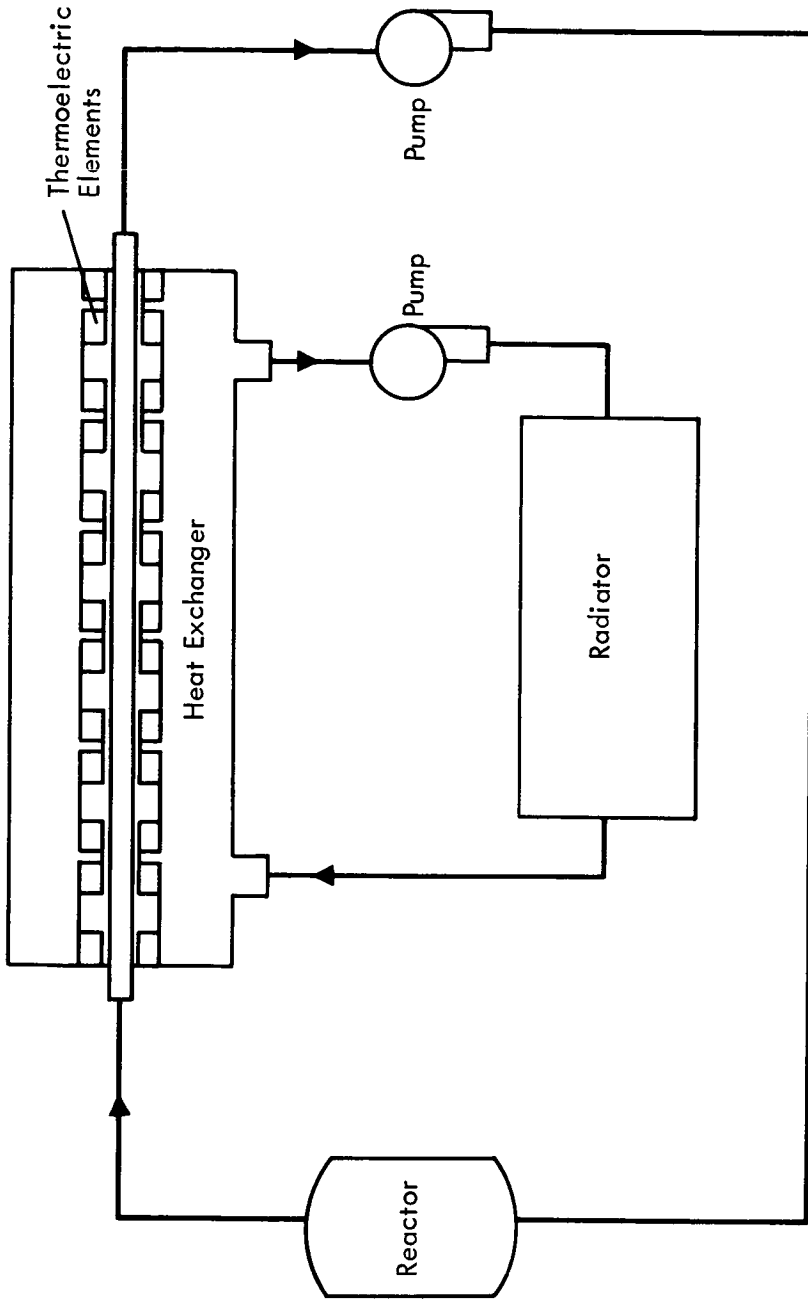
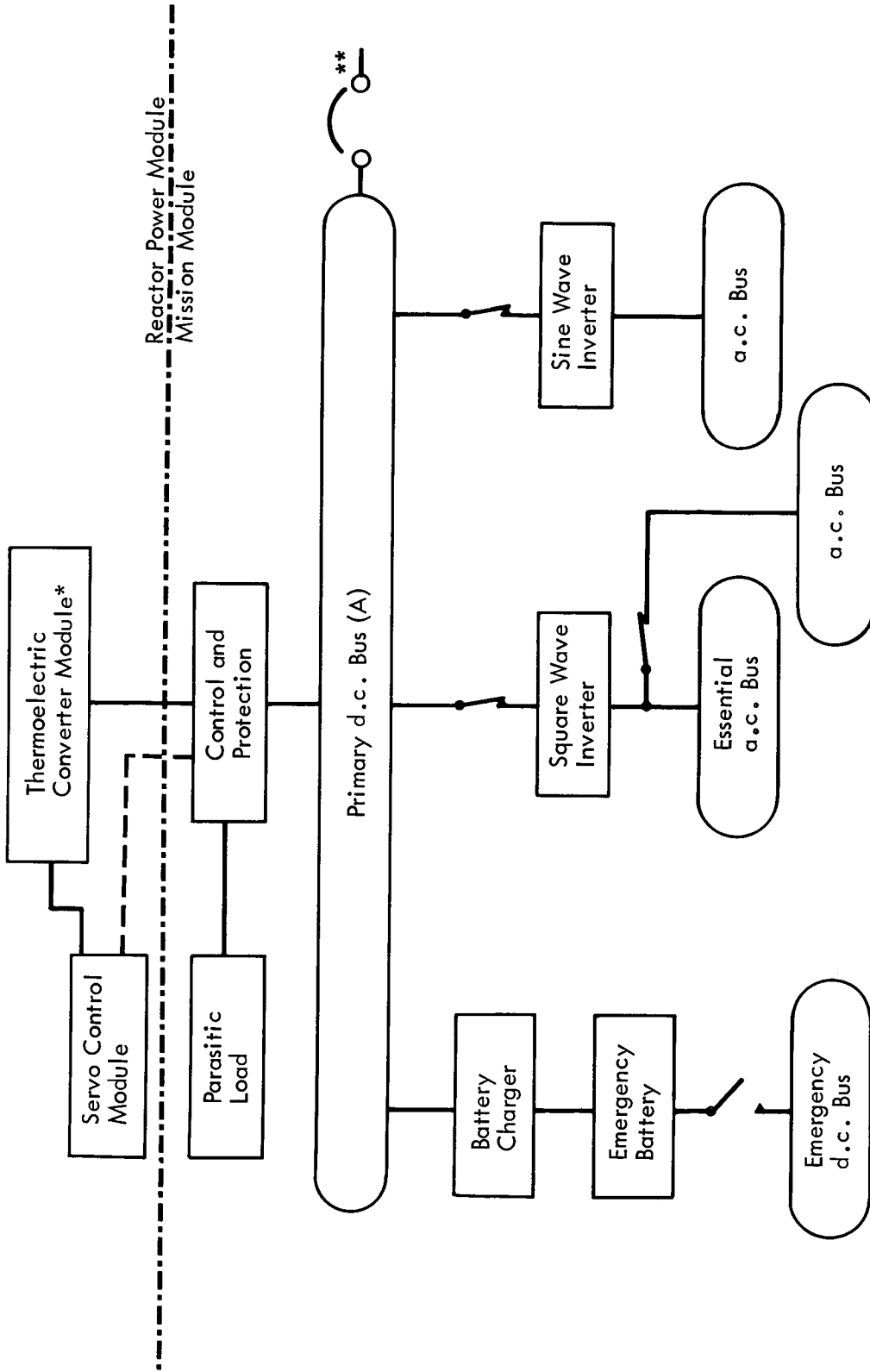

Figure A-10: REACTOR/THERMOELECTRIC CONVERSION SCHEMATIC



*One of several in parallel

**Cross-connection to other parallel buses

Figure A-11: TYPICAL POWER DISTRIBUTION SYSTEM

Table A-25: REACTOR-SiGe THERMOELECTRIC

Identification/ Nomenclature	Weight (lb)	Power (kw)	Area/ Volume	Lead Time		Cost (in millions)		Remarks
				Technology	R&D	R&D**	First Article	
Reactor and Shields	10,375	472.0		1.5	3.5	122.1	10.0	Produces electrical & thermal power equivalent to other concepts. (3) (11) (3)
NaK Loop	270							
Boom & Cable	2900							(3) (11)
Reactor Disposal System	510							(3) (11)
In-Pile Electron	300							(3) (11)
Converter-- Radiator	2270	15.0						(3) (11)
Voltage Regulation	200							
Inverters	93							
Structure	2980							(3)
Monitor, Control Switching & Dist	846							Same for all concepts
Thermal Integ	50							
Emer. Battery	150							5 lbs/kwhr
	<u>20,944</u>							
Spares and Redundancies	572							500 day spares

*enter area or volume if pertinent **including flight test

A-5.3.4 DESCRIPTION OF THE REACTOR/THERMIONIC CONVERSION SUBSYSTEM

The thermionic converter is simply two metal electrodes separated by a small gap. Heat is applied to one metal electrode from an energy source such as a nuclear fuel. As the metal temperature increases, electrons are boiled off the hot electrode and collected by the cooler electrode. Emission and capture of electrons provide the current flow through the external circuit.

The main advantage of the inpile thermionic conversion system is the high source temperature. The problem faced by most space power systems is the temperature limit imposed by the liquid-metal corrosion limit and/or the high temperature strength characteristics of materials. This limitation is avoided by not exposing the liquid metal heat transfer fluid to the high temperature source. Instead, the liquid metal is exposed only to the collector, which is at the point of heat rejection.

Some of the more important characteristics of the inpile thermionic conversion system are presented as Table A-26. Figure A-12 shows a simple diagram of the thermionic conversion process, as well as some typical onpile hardware. Onpile equipment is shown because it conveys an idea of the process more simply than would a diagram of the inpile equipment. There are a number of different basic geometries that can be used in the design of the inpile converter element. Some of these geometries are shown in Figure A-13. An equipment component list for the inpile system is provided as Table A-27. Power control and distribution will be similar to that shown for the thermoelectric conversion concept in Figure A-11.

Table A-26: REACTOR-THERMIONIC SUBSYSTEM CHARACTERISTICS

Reactor

Type	High Temperature-Fast Reactor
Reactor thermal power	100 kw _t
Emitter temperature	≈2000 K
Rated life	3 years
Primary loop coolant	NaK - 78
Envelope diameter at reactor core midplane	24.7 inches

Shield

Gamma shield material	Depleted U-8% Mo
Neutron shield material	Natural lithium hydride
Neutron shield containment material	Type 347 SS
Reactor-vehicle separation distance	125 feet
Dose plane diameter	80 feet
Dose rate at vehicle	20 REM/yr

Power Conversion Module

Converter	Inpile
Efficiency	15%

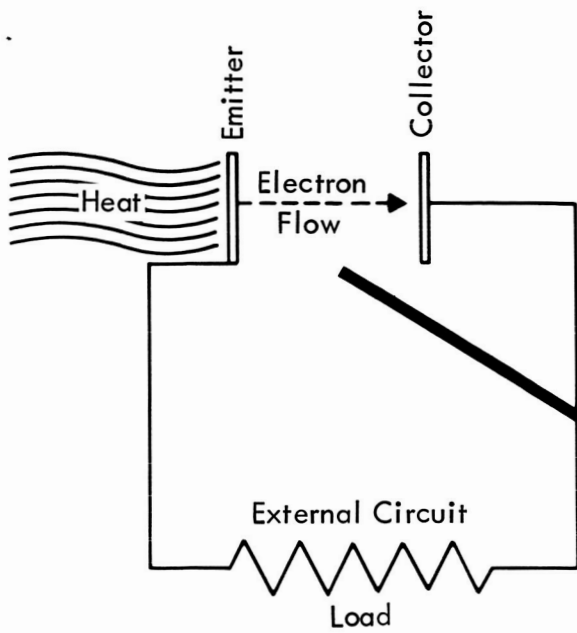

Basic Thermionic Process

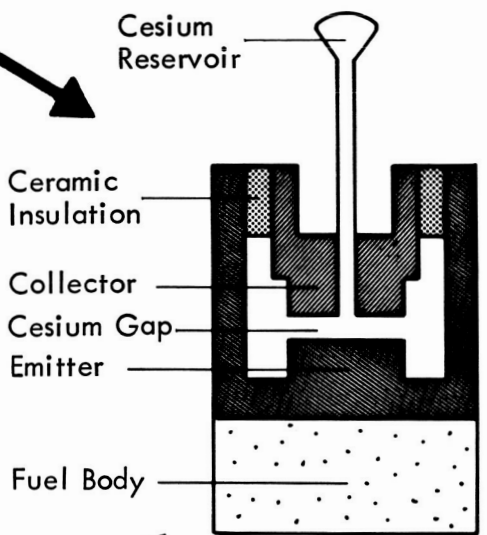

Thermionic Converter

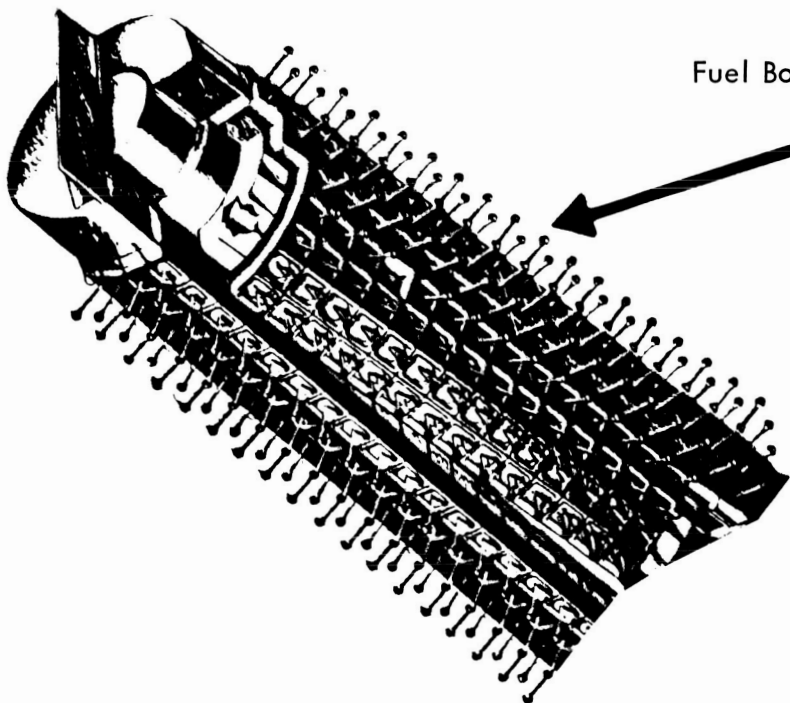

Typical Onpile Installation (STAR-R)

Figure A-12: THERMIONIC PROCESS AND EQUIPMENT

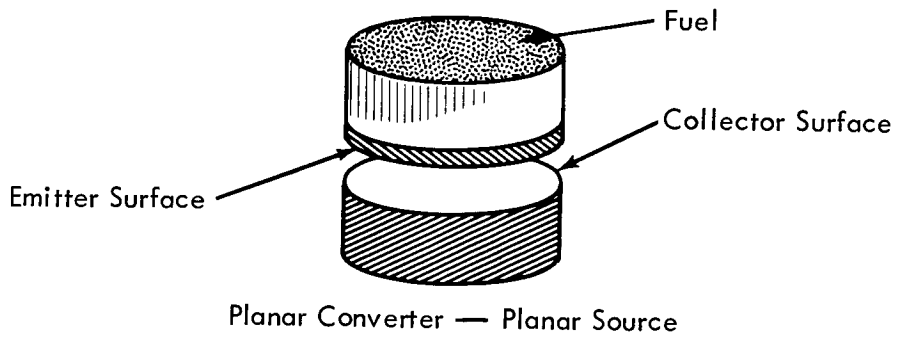
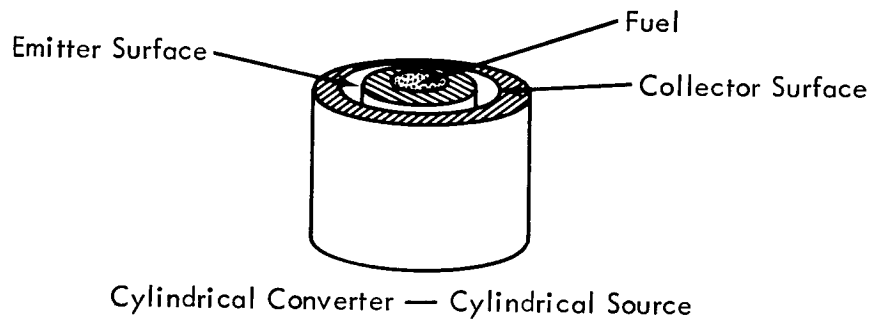
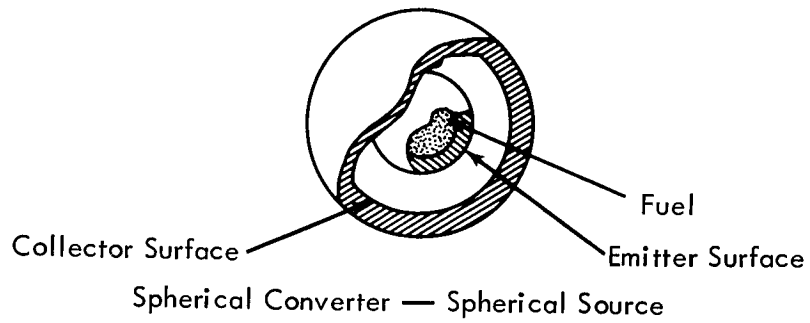

Figure A-13: TYPICAL CONVERTER-SOURCE GEOMETRIES FOR INPILE THERMIONIC CONVERSION

Table A-27: REACTOR-THERMIONIC CONVERSION

Identification/ Nomenclature	Weight (lb)	Power (kw)	Area/ % Volume	Lead Time		Cost (in millions)		Remarks
				Technology	R&D	R&D**	First Article	
Reactor and Shields	8850	135.0		5.0	3.5	163.0	12.9	(3) Includes thermionics
Boom and Cable	2850							(3)
Dc/Dc Converter Regulators	120	15.0						(3)
Reactor Disposal System	510							(3) (11)
Inverters	93							
Thermal Integ.	50							
Emer. Battery	50							
Monitor, Control Switching & Dist	846							
	<u>13,369</u>							
Spares and Redundancies	189							500-day spares

*enter area or volume if pertinent **including flight test

A-6.0 ESTIMATED COSTS

Electrical power subsystem costs were estimated according to the ground rules stated in Section A-6.1. Costs are shown in Table A-28 as well as on the concept data sheets included in Section A-5.0.

A-6.1 COSTING GROUND RULES AND ASSUMPTIONS

- Costs shown are for complete electrical power subsystems and include subsystem integration and testing.
- All three alternate solar array power systems produce 25.51 kilowatts of electrical power for all missions. With the exception of the array, batteries, and spares all other components in the solar array power systems are assumed to be the same. Array panel area varies in relation to its specific weight, efficiency, and distance to the sun.
- R&D cost for the solar array power systems is shown against the Mars orbital mission only and assumes array will be designed so panel size can be varied without effecting the functioning of the solar array or other components, and that no requalification testing is required for the Earth and Venus missions.
- Spares are not included for the solar array panels.
- No learning is considered in the development of unit cost.

Table A-28: ESTIMATED COSTS FOR ELECTRICAL POWER SUBSYSTEM CONCEPTS

Concept	Weight (lb)		Cost (dollars in millions)			
			Panel Area (ft ²)	N/R R&D	Recurring Cost	
	S/S	Spares			Unit No. 1	Spares
CdS Thin Film Array -						
25.51 kw						
Mars orbital	6,553	294	7,908	88.800	22,205	.126
Venus orbital	3,176	310	2,857		13.701	.133
Earth orbital (2 yrs)	3,903	345	3,954		16.201	.148
(3 yrs)		403				.173
(5 yrs)		1,175				.504
4 Mil Si Array -						
25.51 kw						
Mars orbital	5,792	294	6,454	84.800	20.505	.126
Venus Orbital	2,894	310	2,321		12.101	.133
Earth orbital (2 yrs)	3,532	345	3,240		14.808	.148
(3 yrs)		403				.173
(5 yrs)		1,175				.504
8 Mil Si Array -						
25.51 kw						
Mars orbital	5,254	294	5,280	80.800	18.805	.126
Venus orbital	2,711	310	1,913		10.801	.133
Earth orbital (2 yrs)	3,245	345			13.001	.148
(3 yrs)		403				.173
(5 yrs)		1,175				.504
Isotope-Brayton	7,492	1,353		101.400	4.900	1.800
Isotope-Rankine	9,017	1,463		96.400	4.400	2.100
Reactor-Brayton	12,727	1,353		138.600	8.600	1.800
Reactor-Rankine	15,422	1,463		128.100	8.900	2.100
Reactor-Thermoelectric	20,944	572		122.100	10.000	1.700
Reactor-Thermionic	13,369	189		163.000	12.900	.200

NOTE: The costs shown above for the isotope power subsystems do not include the cost of fuel. Pu-238 fuel can be purchased outright or leased from the AEC. Purchase price is estimated at \$550 per thermal watt. Lease price can be determined from the following equation.

$$C = cP(i t + D + n r + R)$$

Where: C = lease cost
c = isotope purchase price per thermal watt @ \$550
P = isotope thermal power at time of delivery
i = interest rate @ 4.75% per year
t = mission duration plus 1 year
D = isotope loss by decay
R = fuel reprocessing charge @ 1.5% of purchase price
r = fuel recovery cost @ 1.0% of purchase price
n = number of flights per fuel assembly

PRECEDING PAGE BLANK NOT FILMED.

D2-113544-6

APPENDIX B

STUDY OF ENVIRONMENTAL CONTROL SUBSYSTEMS

CONTENTS

	<u>Page</u>
B-1.0 ENVIRONMENTAL CONTROL	134
B-2.0 GROUND RULES AND ASSUMPTIONS	135
B-3.0 CO ₂ REMOVAL—O ₂ SUPPLY CONCEPTS	136
B-4.0 DISCUSSION OF COMPARISON METHODS	137
B-4.1 Design Points	137
B-4.2 Cost Equations	138
B-5.0 CONCEPT DETAILS	140
B-5.1 CO ₂ Removal	140
B-5.1.1 Molecular Sieves	140
B-5.1.2 Electrodialysis	142
B-5.1.3 Solid Amines	144
B-5.2 Oxygen Recovery	147
B-5.2.1 Bosch	147
B-5.2.2 Sabatier	151
B-5.2.3 Solid Electrolyte	153
B-5.3 Molten Electrolyte	155
B-5.4 Subcritical O ₂ Storage	157
B-6.0 CALCULATIONS AND SUMMARY DATA	159
B-6.1 Expendable Rates for Individual Concepts	159
B-6.2 Expendable Rates for Combinations	161
B-6.3 Weight and Power for Individual Concepts	162
B-6.4 Weight and Power for Combinations	162
B-6.4.1 Bosch for Use With Molecular Sieve and Solid Amine	162
B-6.4.2 Sabatier for Use With Molecular Sieve and Solid Amine	163
B-6.4.3 Solid Electrolyte for Use With Molecular Sieve and Solid Amine	164
B-6.4.4 Subcritical Storage for Use With Molecular Sieve and Solid Amine	164
B-6.4.5 Subcritical Storage for Use With Electrodialysis	165
B-6.4.6 Molecular Sieve for Use With Subcritical Storage	165
B-6.4.7 Solid Amine for Use With Subcritical Storage	165
B-6.4.8 Electrodialysis for Use With Subcritical Storage	166
B-6.4.9 Bosch for Use With Electrodialysis	166
B-6.4.10 Sabatier for Use With Electrodialysis	167
B-6.4.11 Solid Electrolyte for Use With Electrodialysis	168

CONTENTS (Continued)

	<u>Page</u>
B-6.5 Weight and Power for Molten Electrolyte	174
B-7.0 ESTIMATED COSTS	176
B-7.1 Costing Ground Rules and Assumptions	176
B-8.0 DEVELOPMENT STATUS	178

B-1.0 ENVIRONMENTAL CONTROL

The environmental control subsystem shall remove carbon dioxide from the cabin atmosphere and supply oxygen to the cabin atmosphere. It shall remove crew-produced carbon dioxide, keeping cabin CO₂ concentration at a fixed level. It shall supply oxygen for the crew, cabin leakage, and air lock losses, keeping cabin O₂ concentration at a fixed level.

B-2.0 GROUND RULES AND ASSUMPTIONS

Crew size:	6 men
CO ₂ production:	2.3 pounds/man-day
Cabin CO ₂ partial pressure:	5 mm Hg
Cabin pressure:	7.0 psia (50% O ₂ and 50% N ₂ , CO ₂ , H ₂ O by partial pressure)
O ₂ supply:	1.96 pounds/man-day plus additional for cabin leakage, air-lock losses, etc.
Cabin volume:	10,000 ft ³
Repressurization:	by high pressure gas storage; allow for one every 200 days; does not affect trade as studied here
Leakage of N ₂ :	make up by high pressure gas; discussed no further
Leakage of CO ₂ :	ignored in calculations
For concepts that recover O ₂ from CO ₂ , all O ₂ makeup shall be by water electrolysis.	
Water electrolysis power:	177 $\frac{\text{watts}}{\text{lb/day of O}_2}$
Water electrolysis unit weight:	7.82 $\frac{\text{lb}}{\text{lb/day of O}_2}$

B-3.0 CO₂ REMOVAL---O₂ SUPPLY CONCEPTS

This study considers the following concepts:

CO₂ Removal: Molecular sieves
 Solid amines
 Electrodialysis

CO₂ Reduction (for O₂ supply):

 Bosch
 Sabatier
 Solid electrolyte

CO₂ Removal and Reduction (for O₂ supply):

 Molten electrolyte

O₂ Supply: Subcritical storage

All the combinations among the CO₂ removal and the CO₂ reduction concepts are considered. The combinations of CO₂ removal and subcritical storage O₂ supply are also considered.

B-4.0 DISCUSSION OF COMPARISON METHODS

B-4.1 DESIGN POINTS

Comparison of the concepts is sensitive to the required O_2 supply rate. The nature of some of the concepts is such that they are at their best at a particular flow rate. Cabin leakage and other losses are presented in various studies at anywhere from 1 to 10 pounds per day of O_2 . Since the CO_2 system shall remove all CO_2 produced by the crew, the weight, expendable rate, and power requirement of the CO_2 removal system will not be affected by O_2 requirements in excess of that for the crew. The electro dialysis CO_2 removal process requires water. However, the water is electrolyzed, producing H_2 and O_2 . The H_2 is not a detriment when the electro dialysis process is coupled with a CO_2 reduction process that requires H_2 , i.e., the Sabatier process. The O_2 will provide part of the cabin O_2 requirement. The Sabatier process requires makeup H_2 from makeup water and provides the O_2 from the makeup water to the cabin along with that retrieved from CO_2 . Since the Sabatier produces equal amounts of oxygen from makeup water and carbon dioxide, it should be optimal at an O_2 requirement that is twice the amount of O_2 available from the CO_2 . Based on these points, it has been decided to compare all the CO_2 removal— O_2 supply concepts at three different O_2 requirements, which are:

- 11.76 pounds/day (10.03 from all CO_2 plus 1.73 makeup)
(crew requirement 11.76)
- 13.73 pounds/day (10.03 from all CO_2 plus 3.7 which is O_2 from
water required by Electro dialysis unit)
(amounts to crew requirement 11.76 plus leakage,
etc. of 1.97)
- 20.06 pounds/day (10.03 from all CO_2 plus 10.03 which is O_2 from
electrolysis of water which provides H_2 to Sabatier)
(amounts to crew requirement 11.76 plus leakage,
etc. of 8.30)

For the two higher O_2 flow rates picked, the weight and power of the CO_2 removal concepts will be the same as for the crew requirement. All concepts are considered both with and without thermal integration.

For the higher O_2 flow rates, the O_2 supply concepts will be affected in weight and power.

- 1) The Bosch will require more weight and power just in the electrolysis unit.
- 2) The Sabatier will, in general, have to reduce more of the available CO_2 and thus will increase in weight for the whole system and will require more power for electrolysis.
- 3) The solid electrolyte will increase in weight and power of the electrolysis unit in general for both higher O_2 rates. However, when in combination with electro dialysis, the following applies: for 13.73 pounds/day, it is just at the point where the solid electrolyte system must reduce all the CO_2 . The electrolysis cell is not needed. For the next higher rate, either the electrolysis unit is required, or more water electrolysis by the electro dialysis unit is required.
- 4) The subcritical storage, for the method we are using to describe the system, has no fixed weight, but will increase in heater power for higher O_2 flow rates.
- 5) The molten electrolyte system will simply increase in size and power of the electrolysis unit.

B-4.2 COST EQUATIONS

For the design points discussed above, total program costs were calculated with the following equations:

$$C_T = C_{nr} + C_{rec} + C_{acc} + C_{spr}$$

where

- C_T = total cost
- C_{nr} = nonrecurring cost
- C_{rec} = recurring costs
- C_{acc} = acceleration costs
- C_{spr} = cost of spares

$$C_{nr} = C_{Te} + C_d$$

where

- C_{Te} = technology development cost
- C_d = R&D costs

$$C_{\text{rec}} = (C_r + C_p \times P_e)(M_1 + M_2)$$

where

- C_r = unit cost of flight hardware
- C_p = specific power cost
- P_e = electrical power required in watts
- M_1 = number of earth-orbital flights
- M_2 = number of interplanetary flights

$$C_{\text{acc}} = M_2 C_4 (W_f + W_r \times T_{L3} + P_e \times P_p + W_{s1}) + C_3 \times W_r \times T_{L2} + C_2 \times W_r \times T_{L1} \\ + C_1 M_1 (W_f + P_e \times P_p) + (W_{s2} + W_{s3} + W_{s4}) + W_r \times T_{M1}$$

where

- C_4 = interplanetary round trip acceleration cost in \$/lb
- W_f = fixed weight
- W_r = weight rate of expendables in pounds/day
- T_{L3} = leg 3 (return leg) time in days
- P_p = power penalty in pounds/watt
- W_{s1} = weight of spares and redundancies for interplanetary mission (500 days)
- C_3 = acceleration cost to planetary orbit
- T_{L2} = leg 2 (planetary orbit) time in days
- C_2 = acceleration cost to outbound trajectory
- T_{L1} = leg 1 (departure leg) time in days
- C_1 = acceleration cost to Earth orbit
- W_{s2} = weight of spares and redundancies for 2 years
- W_{s3} = weight of spares and redundancies for 3 years
- W_{s4} = weight of spares and redundancies for 5 year missions
- T_{M1} = total number of days in Earth orbit

$$C_{\text{spr}} = C_{\text{sw}} (M_2 \times W_{s1} + W_{s2} + W_{s3} + W_{s4})$$

where

- C_{sw} = cost of spares in \$/lb (unit cost/unit weight)

B-5.0 CONCEPT DETAILS

Each CO₂ removal concept and each O₂ supply concept is described separately in the following sections, except for the molten electrolyte, which performs both functions. In the descriptions, requirements for water, hydrogen, and oxygen are expressed as makeup water. The material balance shown on the schematic figure for each concept is based strictly on metabolic requirements. However, all calculations of expendable rates, weight, and power for a combined CO₂ removal/O₂ supply subsystem take into account the interrelationship of the CO₂ removal portion and the O₂ supply portion. The calculations for a combined subsystem also include the assumed leakage rates.

B-5.1 CO₂ REMOVAL

B-5.1.1 MOLECULAR SIEVES

Description—A flow schematic of a molecular sieve CO₂ removal concept is shown in Figure B-1. Cabin air passes through one of the alternate silica gel beds. Here the air is dried to a few parts per million (dew point temperature less than -70°F) to allow removal of the CO₂ without H₂O contaminating the molecular sieve bed. From the silica gel bed the process air is routed to one of the molecular sieve beds for CO₂ removal. The flow, upon leaving the molecular sieve bed, passes through the circulation blower. From the blower outlet, the flow is routed through the second silica gel canister where it is warmed to a temperature high enough to desorb the offline silica gel bed. The moisture trapped in the absorption cycle is driven off this stage and returned with the process air to the primary circulation equipment for removal by the humidity control equipment. During this time the offline molecular sieve bed is desorbed of its CO₂.

The CO₂ is desorbed and delivered to a CO₂ storage tank by heating the molecular sieve canister with a transport fluid circulating through a coil immersed in the bed. As noted in Figure B-1 the same coil provides heating and cooling. After the CO₂ is driven off, the bed is cooled by circulating a cooling fluid through the coil. Heating is not required during the complete desorption cycle. By cooling prior to absorption and during absorption, the absorption efficiency is improved, thus decreasing the physical dimensions of the canisters. For efficient operation the molecular sieve bed and silica gel bed should be heated to 350°F and 250°F respectively during regeneration. A cooling fluid of 60°F is desirable during the cooling phase.

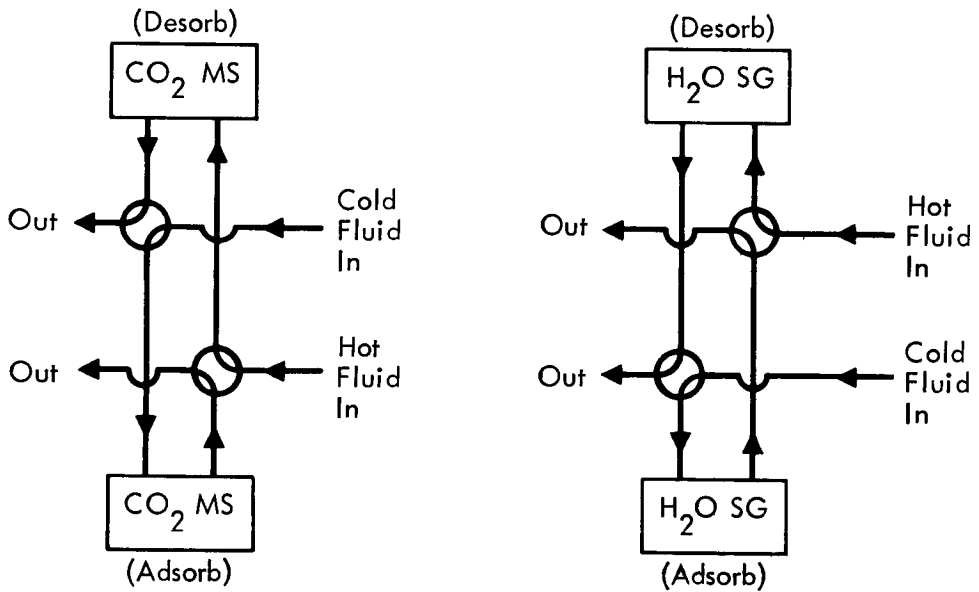
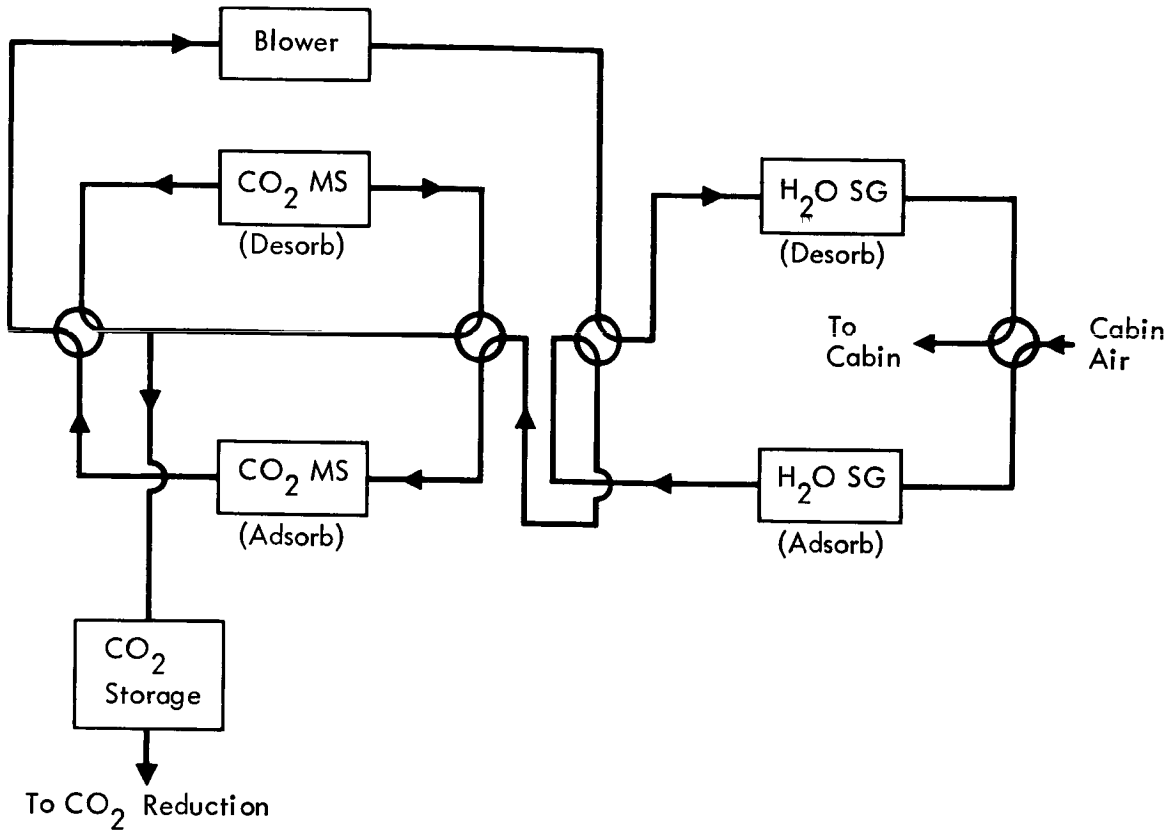

Figure B-1: CO₂ REMOVAL — MOLECULAR SIEVES

Weight and Power—Estimated fixed weight and power for a basic six-man molecular sieve CO₂ removal concept as given in Table B-1 was obtained by a review of Reference 36.

Table B-1: MOLECULAR SIEVES--WEIGHT AND POWER
(WITH THERMAL INTEGRATION)

Component	Weight (pounds)	Power (watts)
Equipment	115	100
Heat Source (at 30 lb/kw)	<u>39</u>	<u>15</u>
Total	154	115

B-5.1.2 ELECTRODIALYSIS

Description—CO₂ removal in this concept is accomplished by means of ion exchange reactions, which convert the CO₂ to ionic species, and by electro dialysis, which causes the ionic species to migrate out of absorption zones. A flow schematic of an electro dialysis concept is shown in Figure B-2. The inlet process air is humidified to assure maintenance of wet membrane areas and is fed to absorber compartments, where the CO₂ in the air is electrochemically converted to carbonate ions. Under the influence of an electrical potential, the carbonate ions are transferred out of the absorber into concentrator compartments, where they react further to reform CO₂ gas. At the electrodes, water is electrolyzed to form oxygen and hydrogen. The processed air minus the CO₂ returns from the absorber to the cabin. The CO₂ exiting from the concentrator is separated from the moisture by a gas-liquid separator and transferred to storage. In addition, the effluent CO₂ may require drying before delivery to the CO₂ reduction equipment.

The water makeup is required for the electro dialysis process and is electrolyzed at the electrodes. Additional separators are used to separate the oxygen generated at the anode and the hydrogen generated at the cathode. The oxygen is routed to the cabin. The hydrogen is surplus and may be vented or, if applicable, routed to the CO₂ reduction system.

Weight and Power—Estimated fixed weight and power breakdown for a basic six-man electro dialysis CO₂ removal concept is presented in Table B-2.

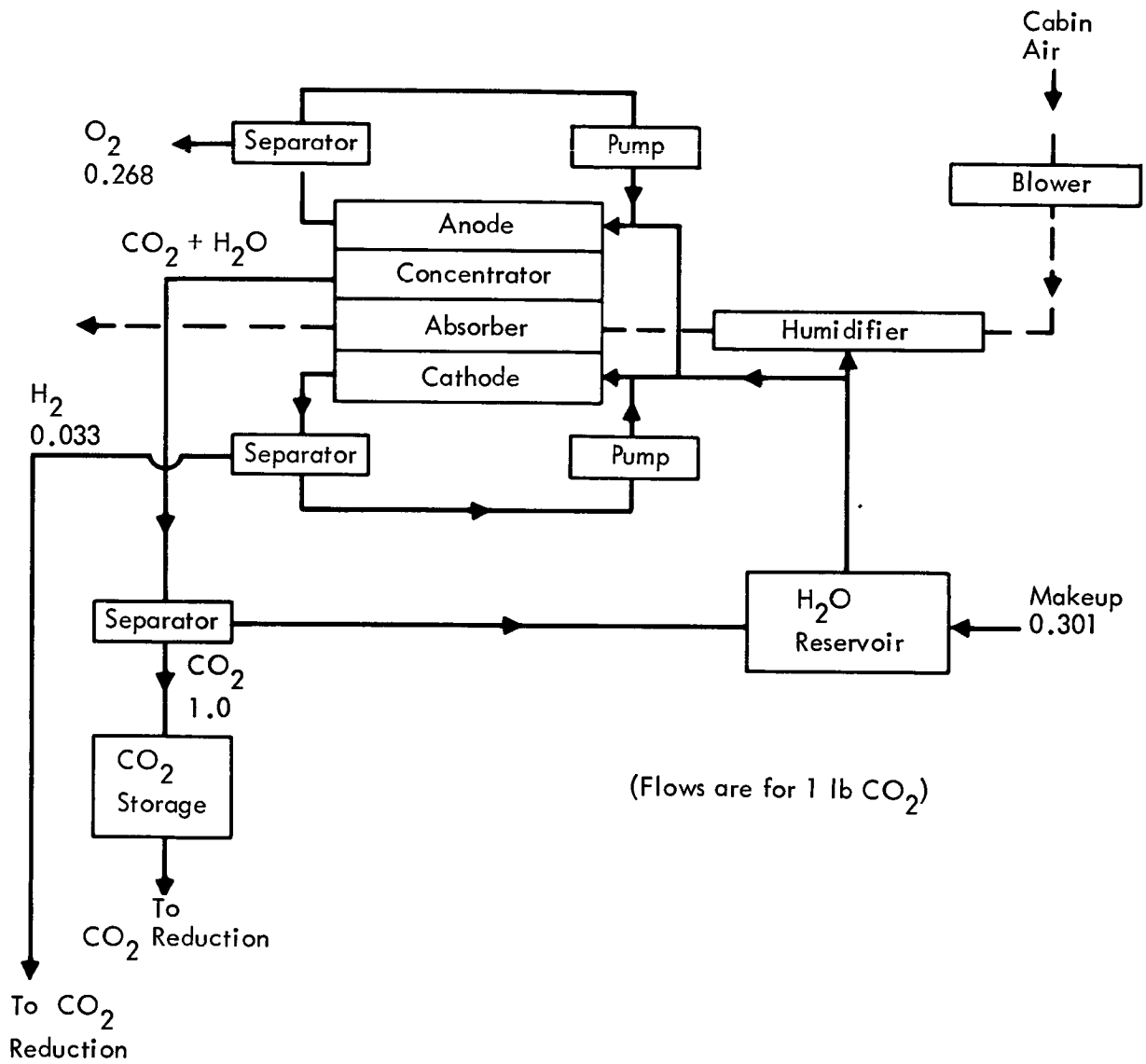

Figure B-2: CO₂ REMOVAL — ELECTRODIALYSIS

Values used are the average of a prototype model and a predicted flight version obtained from Reference 38.

Table B-2: ELECTRODIALYSIS--WEIGHT AND POWER

Component	Weight (pounds)	Power (watts)
Primary Unit	74	624
Auxiliaries	<u>20</u>	<u>225</u>
Total	94	849

As noted in Figure B-2, 0.268 lbs O₂/day/1.0 lb CO₂/day is generated, and 0.301 lbs H₂O/day/1.0 lb CO₂/day is required as makeup. Therefore, the following credit and expendable weight will be considered for a complete CO₂ removal - O₂ generation concept:

$$\text{H}_2\text{O makeup} = 0.301 \frac{\text{lbH}_2\text{O}}{\text{lbCO}_2} \times 2.3 \frac{\text{lbCO}_2}{\text{man-day}} \times 6 \text{ men} = 4.16 \text{ lb H}_2\text{O/day}$$

$$\text{H}_2\text{O makeup plus container} = 4.16 \times 1.05 = 4.37 \text{ lb/day}$$

$$\text{O}_2 \text{ production} = 0.268 \frac{\text{lbO}_2}{\text{lbCO}_2} \times 2.3 \frac{\text{lbCO}_2}{\text{man-day}} \times 6 \text{ men} = 3.7 \text{ lb O}_2/\text{day}$$

$$\text{H}_2 \text{ production} = 0.0335 \frac{\text{lbH}_2}{\text{lbCO}_2} \times 2.3 \frac{\text{lbCO}_2}{\text{man-day}} \times 6 \text{ men} = 0.462 \text{ lb H}_2/\text{day}$$

B-5.1.3 SOLID AMINES

Description—A flow schematic of a solid amine CO₂ removal concept is shown in Figure B-3. The solid amine concept uses three separate solid absorption beds consisting of silica gel (approximately 85%), ethylene glycol, and solid salts of amino acid. This material absorbs CO₂ from cabin gas without the need for removal of water from the gas prior to CO₂ absorption. The three beds are housed in a drum which is rotated 120 degrees approximately every 20 minutes inside a pressure-tight housing with sliding seal-connections on the ends to provide switching through the complete removal cycle.

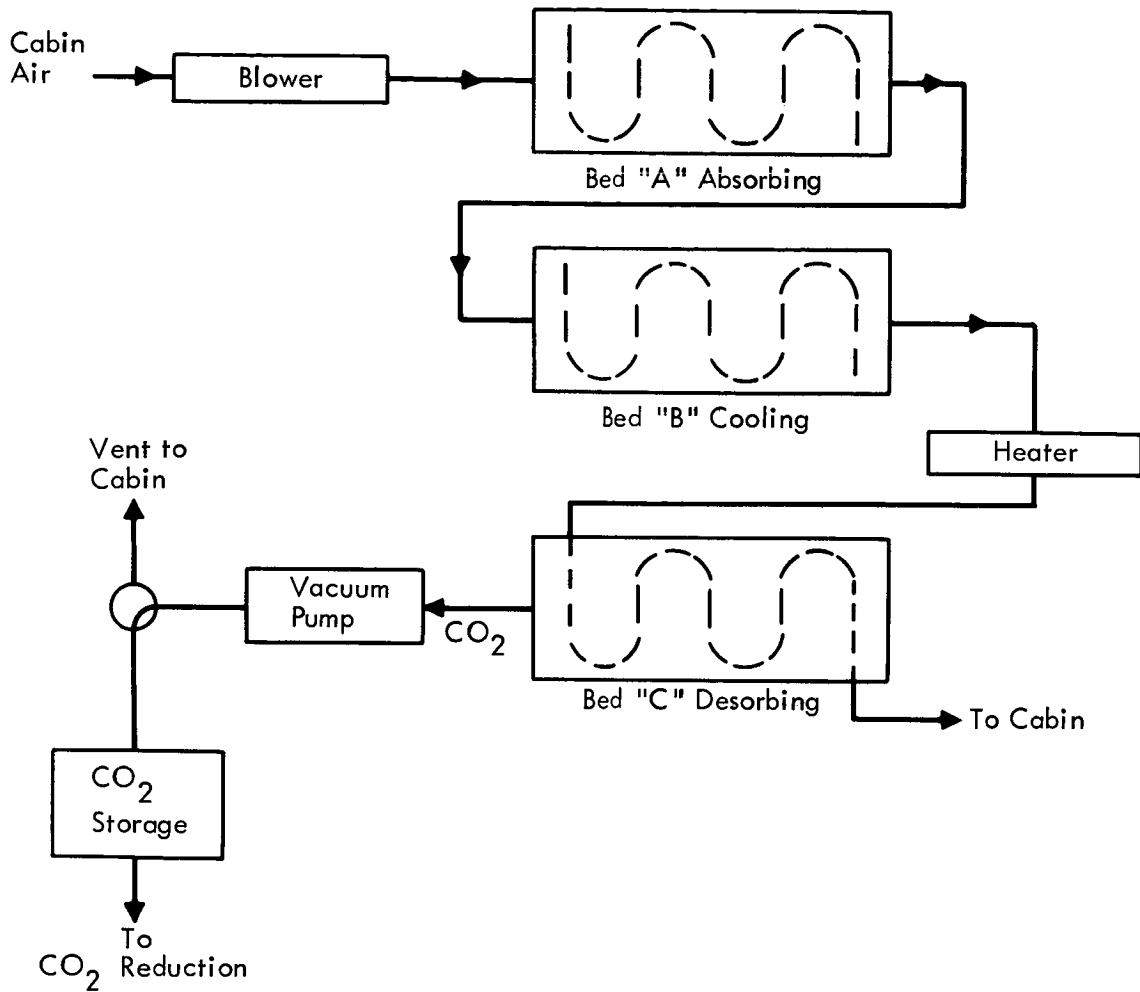

Figure B-3: CO₂ REMOVAL — SOLID AMINES

Operation of this concept is as follows. Cabin gas is fed to the unit by a blower. Bed "A" absorbs CO₂ from the cabin gas. The exiting gas then passes through bed "B", which is in the cooling phase of the cycle, and recovers the sensible heat which bed "B" acquired during the desorption phase. The heated gas passes through the heat transfer tubes within bed "C", heating the bed up to 175°F. The gas stream entering the heat exchanger in bed "C" is additionally heated during the last 10 minutes of the 20-minute period by an electric heater or an additional heat exchanger utilizing waste heat from external fluids above 175°F. (Elevated temperatures may result in decomposition of the amines. This temperature limitation requires the use of a combination of heat and vacuum for desorption.) Heating of bed "C" progresses from one end to the other rather than as a gradual and uniform heating of the entire bed. The gas stream leaving the heat transfer tubes remains for most of the heating cycle at a temperature relatively near cabin ambient temperature, even though the bed is being heated progressively to 175°F starting from the CO₂ outlet end and ending at the CO₂ inlet end. For a short period near the end of the desorption, the gas leaving the heat exchanger tubes will be nearly 175°F.

At the start of desorption, bed "C" is sealed off and evacuated from cabin pressure down to 25 millimeters of mercury absolute by a vacuum pump. Pressure below 20 millimeters of mercury may decrease the absorption capacity. The vacuum pump discharge passes through a three-way valve into the cabin atmosphere until the bed pressure drops to 25 millimeters of mercury. The pneumatically self-operated three-way valve automatically switches at this pressure, and the vacuum pump discharge passes into a line leading to a CO₂ storage tank.

Weight and Power—Estimated fixed weight and power for a basic six-man solid amine CO₂ removal concept, as given in Table B-3, was obtained by a review of Reference 37. Values used are the average of a prototype model and a predicted flight version.

Table B-3: SOLID AMINES--WEIGHT AND POWER
(WITH THERMAL INTEGRATION)

Component	Weight (pounds)	Power (watts)
Absorbent	90	
Hardware and Insulation	59	▷ 305
Heat Source (at 30 lb/kw)	<u>9</u>	<u>2</u>
Total	158	307

▷ Vacuum blower = 240 watts, timer = 20 watts, air circulation blower = 45 watts

B-5.2 OXYGEN RECOVERY

B-5.2.1 BOSCH

Description—The Bosch CO₂ reduction concept, as shown in Figure B-4, is based on the following primary reaction:

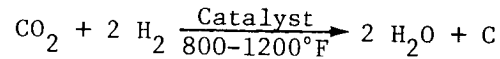

Secondary reactions include:



In this concept, gases from the secondary reactions (CH₄, CO, and unreacted H₂) are mixed with CO₂ from the CO₂ removal equipment and H₂ from the electrolysis cell. These gases then flow through the regenerative heat exchanger to the reactor. Gases leaving the reactor are cooled in the regenerative heat exchanger. Further cooling of the gases below the dew point temperature by a second heat exchanger condenses a portion of the water in the gas stream. The condensed water is removed by the water separator and pumped to the electrolysis cell along with additional makeup water. The electrolysis cell dissociates the water into H₂ at the cathode and O₂ at the anode. The O₂ flows into the cabin atmosphere and the H₂ is directed to the mixing tank. During the primary reaction, soft carbon is formed on the catalyst in the reactor. Removal of this carbon is a major development problem. A flow schematic of carbon removal technique proposed by TRW (Reference 39) is shown in Figure B-5. Carbon from the catalyst surface is carried from the reactor into porous stainless steel filters by the recirculating reaction gases. While one filter is removing carbon, the second filter is idle or is being cleaned by back flow into the carbon collector. The CO₂ reduction process does not require makeup water. The makeup water is provided to produce by electrolysis the oxygen makeup necessary for the crew requirement and for leakage.

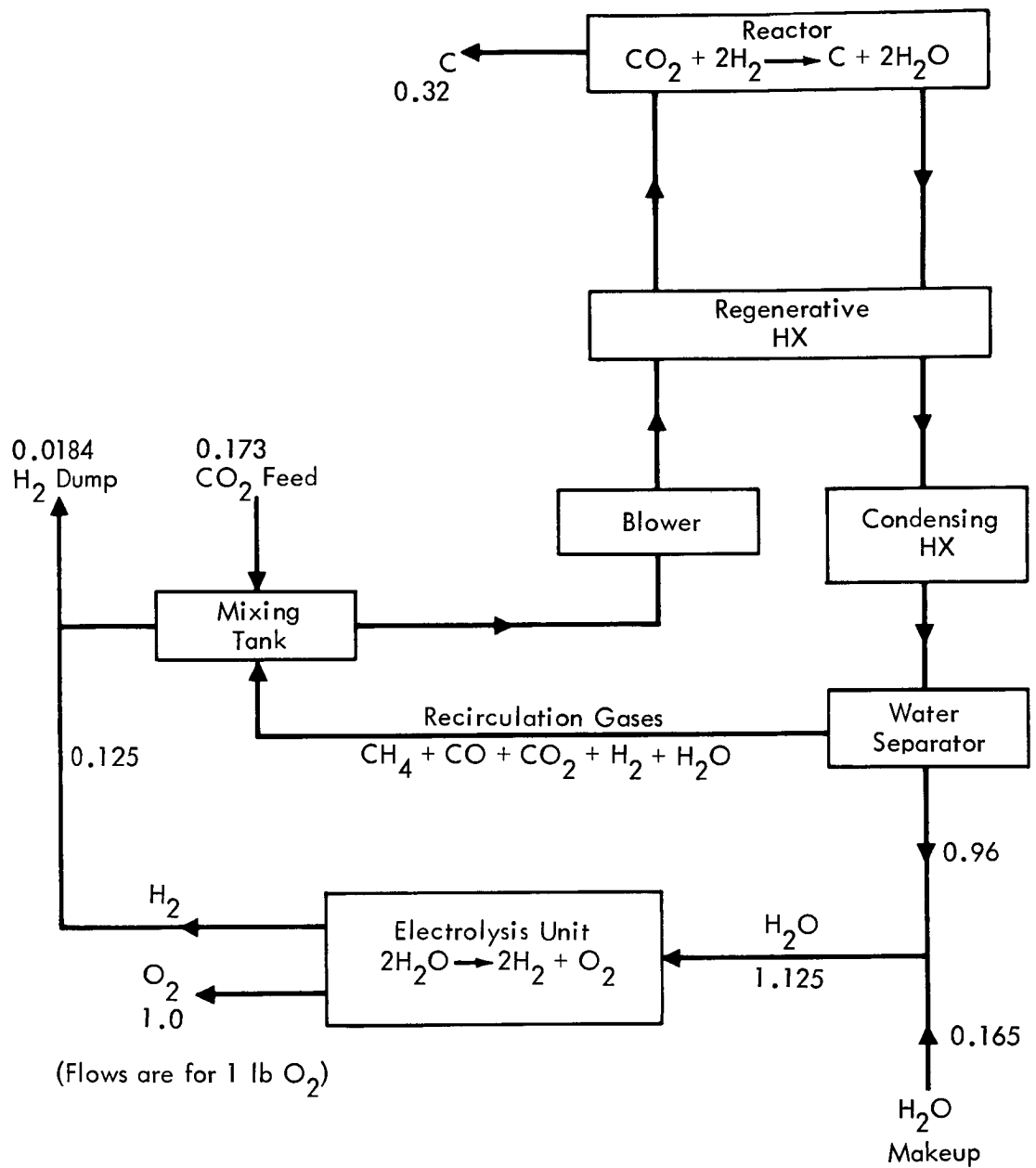

Figure B-4: O₂ RECOVERY — BOSCH

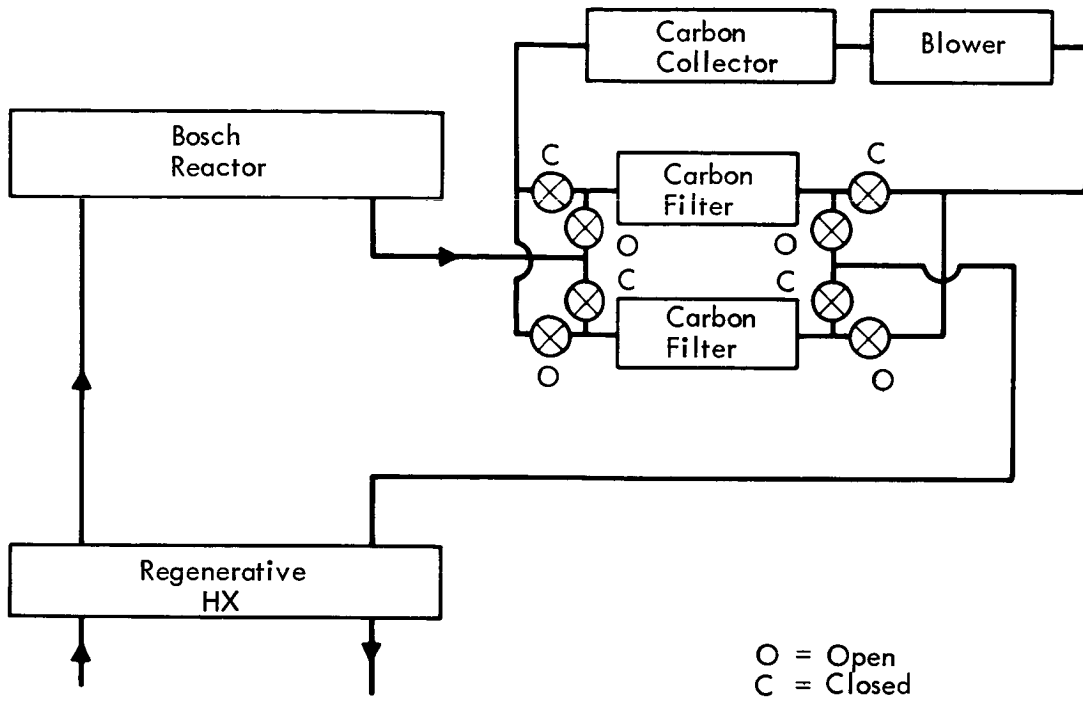

Figure B-5: CARBON REMOVAL — BOSCH

Weight and Power—An estimated fixed weight and power breakdown for a basic six-man system Bosch O₂ recovery concept is presented in Table B-4. Values used are the average of concepts proposed by the Electromechanical Division of Thompson Ramo Wooldridge, Inc. (Reference 40) and the Mechanics Research Division of General American Transportation Company (Reference 41). Weight penalties are not included for storage of the carbon, since it may be stored in other containers as they are emptied.

Table B-4: BOSCH--WEIGHT AND POWER

Component	Weight (pounds)	Power (watts)
Reactor	82	400
Condenser-Separator	3	-
Electrolysis Unit	92	2080
Blower	8	100
Heat Exchanger	9	-
Instrumentation and Controls	9	35
Filter Equipment	<u>11</u>	<u>-</u>
Total	214	2615

As noted in Figure B-4, 0.165 lb H₂O/1.0 lb O₂ is required as makeup.

$$0.165 \frac{\text{lbH}_2\text{O}}{\text{lbO}_2} \times 1.96 \frac{\text{lbO}_2}{\text{man-day}} \times 6 \text{ men} = 1.94 \text{ lb H}_2\text{O/day}$$

$$\text{H}_2\text{O makeup plus container} = 1.94 \times 1.05 = 2.04 \text{ pounds/day}$$

$$\text{Expendable catalyst} = \frac{\frac{12}{44} (13.8 \text{ lb CO}_2/\text{day})}{50 \text{ lb C/lb catalyst}} = 0.0753 \text{ pound/day}$$

$$\text{Catalyst plus container} = 0.0753 \times 1.10 = 0.083 \text{ pound/day.}$$

B-5.2.2 SABATIER

Description—The Sabatier CO₂ reduction system, as shown in Figure B-6, is based on the following reaction:

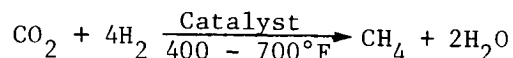

In this concept, H₂ from the electrolysis unit is mixed with CO₂ from the collection equipment. These gases then flow through the catalytic reactor where CH₄ and H₂O are produced. Gases leaving the reactor are then cooled below the dew point temperature by the condensing heat exchanger. The condensed water is removed by the water separator and pumped to the electrolysis cell along with additional makeup water. The electrolysis cell dissociates the water into H₂ at the cathode and O₂ at the anode. The O₂ flows into the cabin atmosphere and the H₂ is directed to the mixing tank. In this study methane is vented to space. There are numerous alternatives which could reduce expendable requirements; however, the feasibility of these approaches has not been verified and is subject to additional research. Reduction of the methane to acetylene may result in weight, power, and expendables similar to the Bosch concept. Since the vented methane carries overboard half the hydrogen required for the Sabatier reaction, water makeup is required.

Weight and Power—An estimated fixed weight and power breakdown for a basic six-man Sabatier O₂ recovery concept is presented in Table B-5.

Table B-5: SABATIER--WEIGHT AND POWER

Component	Weight (pounds)	Power (watts)
Reactor	6	-
Condenser-Separator	5	-
Electrolysis Unit	92	2080
Instrumentation and Controls	<u>6</u>	<u>30</u>
Total	109	2110

The required makeup water provides additional oxygen in a quantity such that, as shown in Figure B-6, all the CO₂ available need not be reduced if producing just the crew O₂ requirement.

As noted in Figure B-6, 0.563 lb H₂O/1.0 lb O₂ is required as makeup considering just the crew requirement. If cabin leakage is considered, it is profitable to use more of the available CO₂.

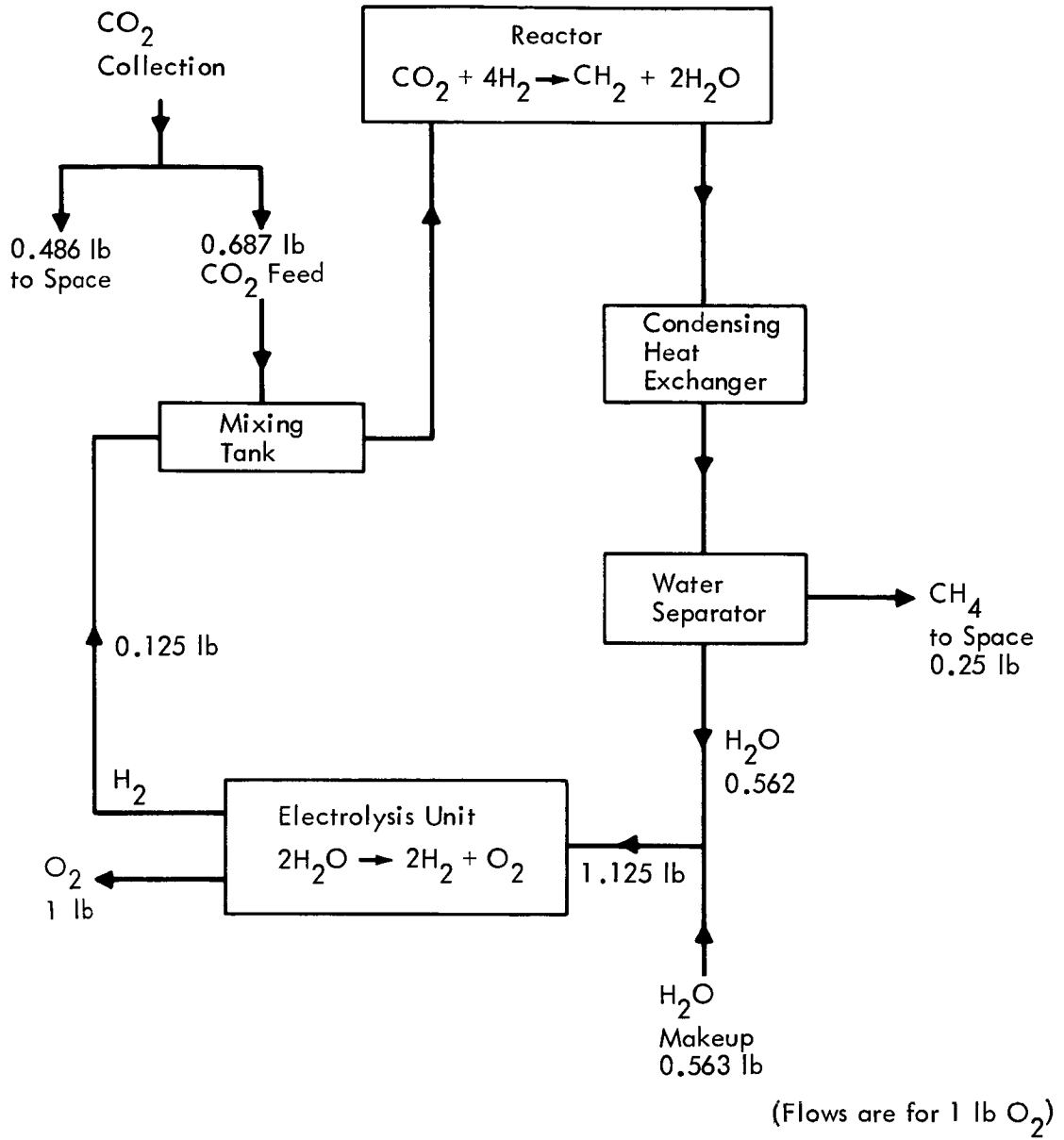

Figure B-6: O₂ RECOVERY — SABATIER

$$0.563 \frac{\text{lbH}_2\text{O}}{\text{lbO}_2} \times 1.96 \frac{\text{lbO}_2}{\text{man-day}} \times 6 \text{ men} = 6.62 \text{ lb H}_2\text{O/day}$$

H₂O makeup plus container = 6.62 x 1.05 = 6.95 pounds/day.

B-5.2.3 SOLID ELECTROLYTE

Description—The solid electrolyte CO₂ reduction concept, as shown in Figure B-7, is based on the following reactions:



In this concept, CO₂ from the CO₂ collection system flows into a solid electrolyte cell operating at approximately 1000°C. O₂ is produced at the anode and CO is produced at the cathode. The CO, along with the untreated CO₂, then flows through a regenerative heat exchanger where the temperature of the gases is reduced to about 500°C. From the regenerative heat exchanger, the gases flow into a catalyst reactor where carbon and CO₂ are formed. The carbon is deposited on an expendable catalyst. The CO₂ and unreacted CO are then cooled by a regenerative heat exchanger and cooler to remove excess heat and to make the temperature entering the recirculation blower compatible with design. These gases then flow through a regenerative heat exchanger to the electrolytic cell to complete the cycle.

Weight and Power—An estimated fixed weight and power breakdown for a basic six-man solid electrolyte O₂ recovery concept as presented in Table B-6 was based on a review of the Hamilton Standard study for the Boeing MORL study (Reference 42).

The water electrolysis unit and the makeup water are not a part of the CO₂ reduction process. The amount of makeup water shown in Figure B-7 is only that amount necessary to satisfy the crew oxygen requirement. If cabin leakage is considered, more makeup water is required.

As noted in Figure B-7, 0.165 lb H₂O/1.0 lb O₂ is required as makeup.

$$0.165 \frac{\text{lbH}_2\text{O}}{\text{lbO}_2} \times 1.96 \frac{\text{lbO}_2}{\text{man-day}} \times 6 \text{ men} = 1.94 \text{ lb H}_2\text{O/day}$$

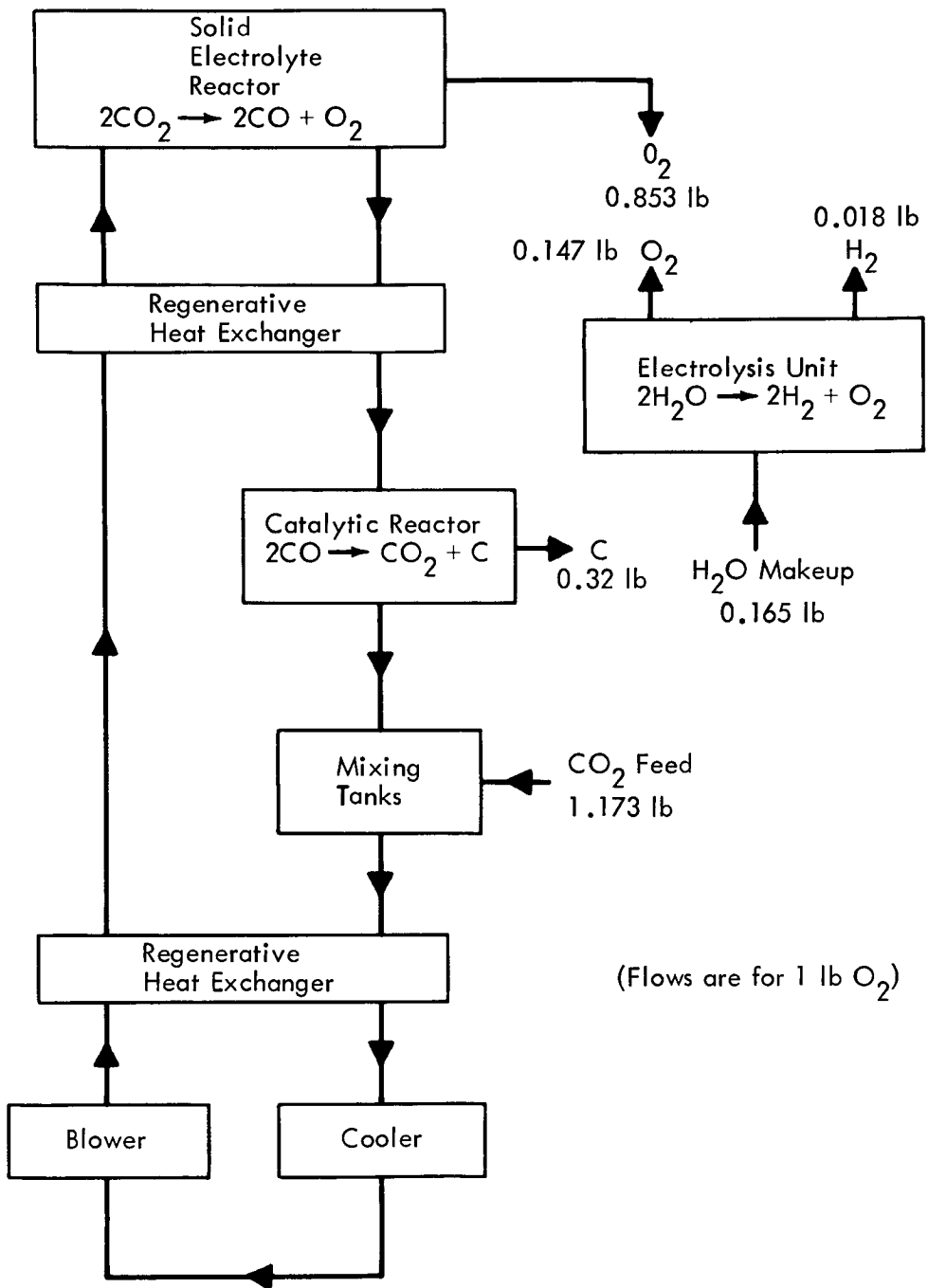

Figure B-7: O_2 RECOVERY — SOLID ELECTROLYTE

H₂O makeup plus container = 1.94 x 1.05 = 2.04 pounds/day.

Carbon formed in the reactor is deposited on an expendable catalyst. Based on replacing the catalyst when the carbon-to-catalyst ratio is 50 to 1, the following catalyst is required.

$$\frac{\frac{12}{44} (13.8 \text{ lb CO}_2/\text{day})}{50 \text{ lb C/lb catalyst}} = 0.0753 \text{ pound catalyst/day}$$

Catalyst plus container = 0.0753 x 1.10 = 0.083 pounds/day.

Table B-6: SOLID ELECTROLYTE--WEIGHT AND POWER

Component	Weight (pounds)	Power (watts)
Catalytic Reactor	122	-
Electrolyte Reactor	125	1800
Blower	6	100
Heat Exchangers	12	-
Instrumentation and Controls	5	30
H ₂ O Electrolysis Unit	<u>14</u>	<u>306</u>
Total	284	2236

B-5.3 MOLTEN ELECTROLYTE

Description—The molten electrolyte CO₂ reduction system, as shown in Figure B-8, is based on the following reactions:



In this concept, a separate CO₂ collection is not required. A blower circulates cabin air through an electrolysis unit. The CO₂ in the air combines with lithium oxide (Li₂O) to form lithium carbonate (Li₂CO₃). Electrolysis of Li₂CO₃ then produces O₂ at the anode and carbon and Li₂O at the cathode. The anode also gives off two parts CO₂ to one part O₂; however, separation and recycling are not necessary because CO₂ is reabsorbed in the melt after release at the anode.

Weight and Power—An estimated fixed weight and power breakdown for a basic six-man molten electrolyte CO₂ removal -O₂ generation concept, as presented in Table B-7, was obtained by a review of Reference 36.

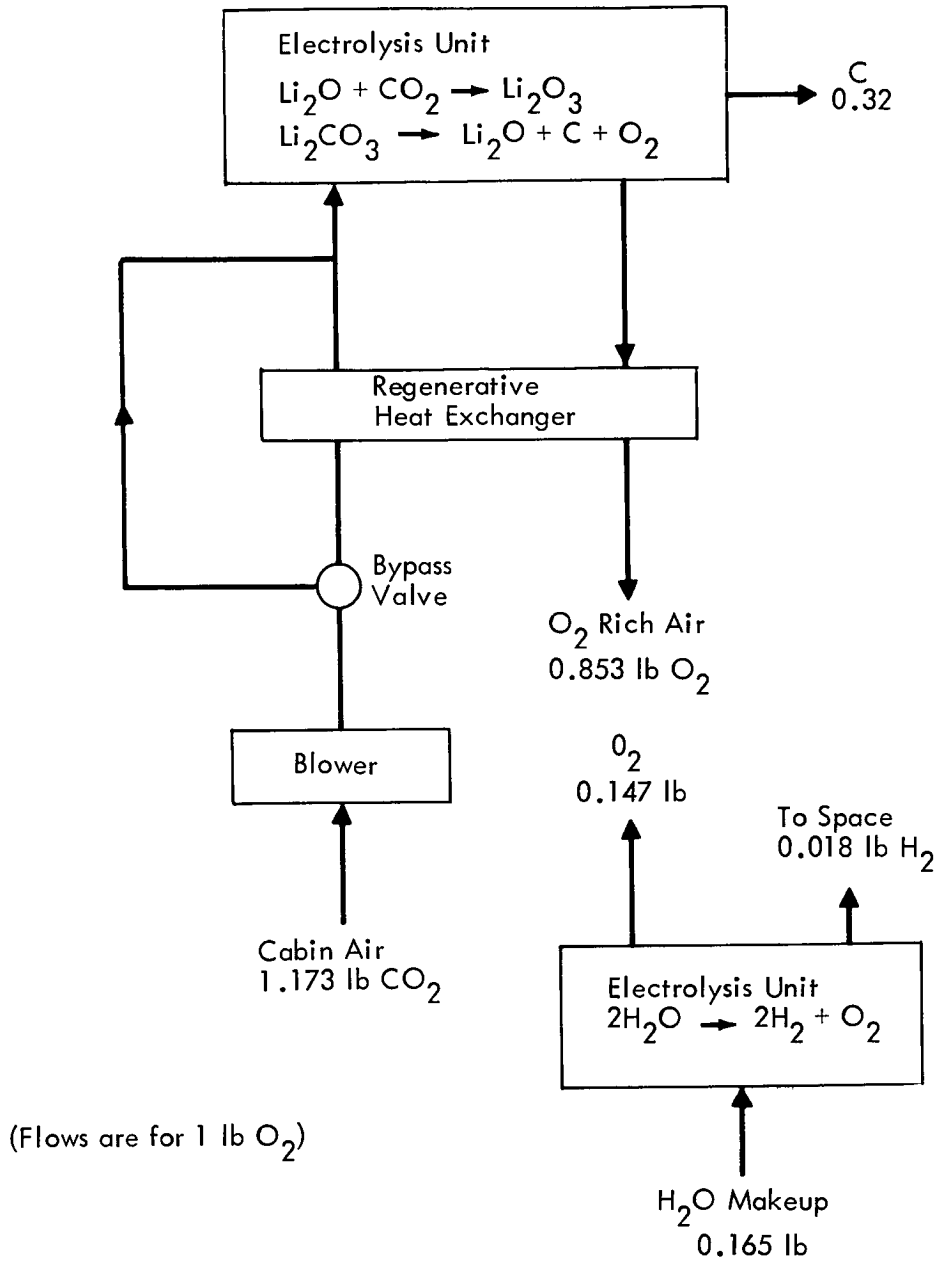

Figure B-8: CO₂ REMOVAL, O₂ RECOVERY — MOLTEN ELECTROLYTE

Table B-7: MOLTEN ELECTROLYTE--WEIGHT AND POWER

Component	Weight (pounds)	Power (watts)
Molten Electrolysis Unit and Associated Equipment	260	1080
H ₂ O Electrolysis Unit	<u>14</u>	<u>306</u>
Total	274	1386

The water electrolysis unit and the makeup water are not a part of the molten electrolyte process. The amount of makeup water shown in Figure B-8 is only that amount necessary to satisfy the crew oxygen requirement. If cabin leakage is considered, more makeup water is required. As noted in Figure B-8, 0.165 lb H₂O/1.0 lb O₂ is required as makeup.

$$0.165 \frac{\text{lbH}_2\text{O}}{\text{lbO}_2} \times 1.96 \frac{\text{lbO}_2}{\text{man-day}} \times 6 \text{ men} = 1.94 \text{ pounds H}_2\text{O/day}$$

$$\text{H}_2\text{O makeup plus container} = 1.94 \times 1.05 = 2.04 \text{ pounds/day.}$$

Additional expendables include replacement of the cathode electrode due to carbon buildup and replacement of chemicals lost by entrainment in the carbon.

$$\text{Electrodes, chemicals and packaging} = 0.36 \text{ pound/day}$$

B-5.4 SUBCRITICAL O₂ STORAGE

O₂ is stored in the subcritical state (see Figure B-9). For crew requirement of 11.76 pounds per day of O₂, 30 watts of heater power is required by the O₂ tank. For this study, tank weight and unavailable O₂ will be apportioned at 0.15 pound per pound of usable O₂ and treated as an expendable in the calculations. For crew requirement only, the expendable rate will be

$$1.96 \frac{\text{lbO}_2}{\text{man-day}} \times 6 \text{ men} \times 1.15 = 13.52 \text{ pounds/day}$$

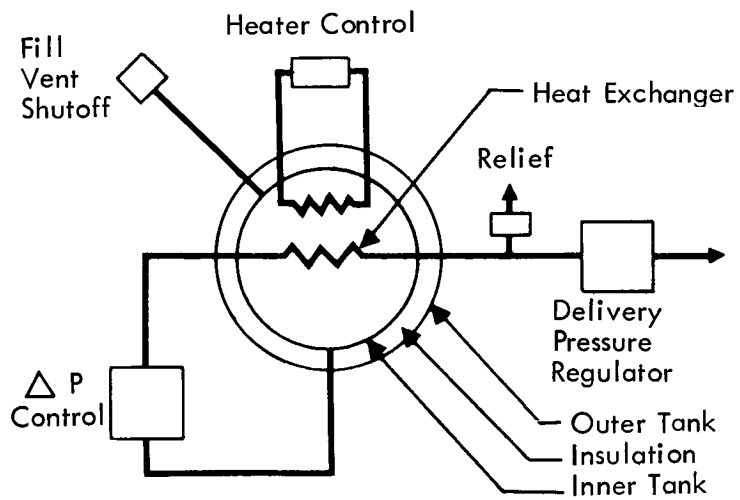

Figure B-9: SUBCRITICAL O₂ STORAGE

B-6.0 CALCULATIONS AND SUMMARY DATA

B-6.1 EXPENDABLE RATES FOR INDIVIDUAL CONCEPTS (Table B-8)

Expendable rates for O₂ requirement = 13.73 pounds/day

Only those are shown which are not the same as for O₂ = 11.76 pounds/day.

Bosch, solid electrolyte, molten electrolyte:

$$O_2 = 13.73 \text{ pounds/day}$$

$$\underline{(-)10.03} \text{ pounds/day of } O_2 \text{ from } CO_2$$

$$3.73 \text{ pounds/day of } O_2 \text{ from makeup water}$$

$$(18/16)(3.7) = 4.16 \text{ pounds/day of } H_2O \text{ makeup}$$

$$(4.16)(1.05) = 4.37 \text{ pounds/day of } H_2O \text{ makeup plus container}$$

Sabatier:

The required makeup water produces half the O₂ required.

$$(13.73/2)(18/16) = 7.73 \text{ pounds/day of } H_2O \text{ makeup}$$

$$(7.73)(1.05) = 8.11 \text{ pounds/day of } H_2O \text{ makeup plus container}$$

Subcritical storage:

$$(13.73)(1.15) = 15.8 \text{ pounds/day of usable } O_2 \text{ plus tankage}$$

Expendable rates for O₂ requirement = 20.06 pounds/day

Only those are shown which are not the same as for O₂ = 11.76 pounds/day.

Bosch, solid electrolyte, molten electrolyte:

$$O_2 = 20.06 \text{ pounds/day}$$

$$\underline{(-)10.03} \text{ pounds/day of } O_2 \text{ from } CO_2$$

$$10.03 \text{ pounds/day of } O_2 \text{ from makeup water}$$

$$(18/16)(10.03) = 11.29 \text{ pounds/day of } H_2O \text{ makeup}$$

$$(11.29)(1.05) = 11.85 \text{ pounds/day of } H_2O \text{ makeup plus container}$$

Table B-8: EXPENDABLE RATES FOR INDIVIDUAL CONCEPTS

Concept	Expendable Required or Useful By-product	O ₂ Requirement, lb/day					
		11.76 (crew)		13.73 (11.76 crew + 1.97 leakage)		20.06 (11.76 crew + 8.3 leakage)	
		Expendable Only	Expendable Plus Tankage or Packaging	Expendable Only	Expendable Plus Tankage or Packaging	Expendable Only	Expendable Plus Tankage or Packaging
CO₂ Removal							
Molecular Sieve	None	0	--	0	--	0	--
Solid Amines	None	0	--	0	--	0	--
Electrolysis	Requires water for process and electrolyzes it (i.e., O ₂ goes back to cabin H ₂ dumped or used elsewhere -- 0.301 lb H ₂ O/lb CO ₂ required.	4.16	4.37	4.16	4.37	4.16	4.37
		3.7	--	3.7	--	3.7	--
O₂ Supply							
Bosch	Water required only to provide crew or other O ₂ not available from CO ₂ . Catalyst required at assumed 50 lb carbon/lb catalyst	1.94	2.04	4.16	4.37	11.29	11.85
		0.0753	0.083	0.0753	0.083	0.0753	0.083
Sabatier	Reaction requires H ₂ and some is lost as CH ₄ so makeup H ₂ O is required.	6.62	6.95	7.73	8.11	11.29	11.85
Solid Electrolyte	Water is required only to provide crew or other O ₂ not available from CO ₂ . Catalyst required at assumed 50 lb carbon/lb catalyst	1.94	2.04	4.16	4.37	11.29	11.85
		0.0753	0.083	0.0753	0.083	0.0753	0.083
Subcritical Storage	The O ₂ expendable rate including tankage, bailoff, etc., is dependent on use rate	11.76	13.52	13.73	15.8	20.06	23.07
Molten Electrolyte	Water is required to provide crew or other O ₂ not available from CO ₂ ; electrodes, chemicals and packaging required	1.94	2.04	4.16	4.37	11.29	11.85
		--	0.36	--	0.36	--	0.36

Sabatier:

The required makeup water produces half the O₂ required.

$$(20.06/2)(18/16) = 11.29 \text{ pounds/day of H}_2\text{O makeup}$$

$$(11.29)(1.05) = 11.85 \text{ pounds/day of H}_2\text{O makeup plus container}$$

Subcritical storage:

$$(20.06)(1.15) = 23.07 \text{ pounds/day of usable O}_2 \text{ plus tankage}$$

B-6.2 EXPENDABLE RATES FOR COMBINATIONS

The net expendable rate for each combined CO₂ removal/O₂ supply concept is presented in Table B-9.

Table B-9: NET EXPENDABLE RATES FOR ECS COMBINATIONS

Concept		O ₂ Requirement, Pounds/Day		
		11.76	13.73	20.06
CO ₂ Removal	O ₂ Supply	Net Expendable Rate, Pounds/Day (includes tankage and packaging)		
Molecular Sieve	Bosch	2.123	4.453	11.933
Molecular Sieve	Sabatier	6.95	8.11	11.85
Molecular Sieve	Solid Electrolyte	2.123	4.453	11.933
Molecular Sieve	Subcritical Storage	13.52	15.8	23.07
Solid Amines	Bosch	2.123	4.453	11.933
Solid Amines	Sabatier	6.95	8.11	11.85
Solid Amines	Solid Electrolyte	2.123	4.453	11.933
Solid Amines	Subcritical Storage	13.52	15.8	23.07
Electrodialysis	Bosch	2.123	4.453	11.933
Electrodialysis	Sabatier	6.946	8.11	11.85
Electrodialysis	Solid Electrolyte	4.436	4.453	11.933
Electrodialysis	Subcritical Storage	13.639	15.905	23.184
	Molten Electrolyte	2.4	4.73	12.21

B-6.3 WEIGHT AND POWER FOR INDIVIDUAL CONCEPTS

O₂ requirement = 11.76 pounds/day

Weight and power are itemized in Section B-5.0 for thermally integrated case. Electrodialysis, solid electrolyte, molten electrolyte, and sub-critical storage do not change for the case of no thermal integration; those that do change are shown below.

	With Thermal Integration		No Thermal Integration	
	Weight (pounds)	Power (watts)	Weight (pounds)	Power (watts)
Molecular sieve equipment	115	100	115	100
Heat source (at 30 lb/kw)	<u>39</u>	<u>15</u>	<u>-</u>	<u>1300</u>
Total	154	115	115	1400
Solid amine absorbent	90	-	90	-
Hardware and insulation	59	305	59	305
Heat source (at 30 lb/kw)	<u>9</u>	<u>2</u>	<u>-</u>	<u>334</u>
Total	158	307	149	639

Since CO₂ removal concepts remove all CO₂, weight and power remain the same at the higher O₂ rates considered.

B-6.4 WEIGHT AND POWER FOR COMBINATIONS

B-6.4.1 BOSCH FOR USE WITH MOLECULAR SIEVE AND SOLID AMINE

O₂ requirement = 13.73 pounds/day
 (13.73)(7.82) = 107.3 pounds
 (13.73)(177) = 2430 watts

	Weight (pounds)	Power (watts)
Electrolysis unit	107.3	2430
Other	<u>122</u>	<u>535</u>
	229.3	2965

Identical for case of no thermal integration.

O_2 requirement = 20.06 pounds/day
 (20.06)(7.82) = 157 pounds
 (20.06)(177) = 3550 watts

	Weight (pounds)	Power (watts)
Electrolysis unit	157	3550
Other	<u>122</u>	<u>535</u>
	279	4085

Identical for case of no thermal integration.

B-6.4.2 SABATIER FOR USE WITH MOLECULAR SIEVE AND SOLID AMINE

O_2 requirement = 13.73 pounds/day
 (13.73)(7.82) = 107.3 pounds
 (13.73)(177) = 2430 watts

	Weight (pounds)	Power (watts)
Electrolysis unit	107.3	2430
Other	<u>17</u>	<u>30</u>
	124.3	2460

Identical for case of no thermal integration.

O_2 requirement = 20.06 pounds/day
 (20.06)(7.82) = 157 pounds
 (20.06)(177) = 3550 watts

	Weight (pounds)	Power (watts)
Electrolysis unit	157	3550
Other	<u>17</u>	<u>30</u>
	174	3580

Identical for case of no thermal integration.

B-6.4.3 SOLID ELECTROLYTE FOR USE WITH MOLECULAR SIEVE AND SOLID AMINE

$$\begin{aligned} \text{O}_2 \text{ requirement} &= 13.73 \text{ pounds/day} \\ &\quad - \underline{10.03} \text{ pounds/day of O}_2 \text{ from CO}_2 \\ &\quad \quad 3.7 \text{ pounds/day of O}_2 \text{ must come} \\ &\quad \quad \quad \text{from water electrolysis unit} \end{aligned}$$

$$(7.82)(3.7) = 28.9 \text{ pounds}$$

$$(177)(3.7) = 655 \text{ watts}$$

	Weight (pounds)	Power (watts)
H ₂ O Electrolysis unit	28.9	655
Other	<u>270</u>	<u>1930</u>
	298.9	2585

Identical for case of no thermal integration.

$$\begin{aligned} \text{O}_2 \text{ requirement} &= 20.06 \text{ pounds/day} \\ &\quad - \underline{10.03} \text{ pounds/day of O}_2 \text{ from CO}_2 \\ &\quad \quad 10.03 \text{ pounds/day of O}_2 \text{ must come} \\ &\quad \quad \quad \text{from water electrolysis unit} \end{aligned}$$

$$(7.82)(10.03) = 78.5 \text{ pounds}$$

$$(177)(10.03) = 1776 \text{ watts}$$

	Weight (pounds)	Power (watts)
H ₂ O Electrolysis unit	78.5	1776
Other	<u>270</u>	<u>1930</u>
	348.5	3706

Identical for case of no thermal integration.

B-6.4.4 SUBCRITICAL STORAGE FOR USE WITH MOLECULAR SIEVE AND SOLID AMINE

$$\begin{aligned} \text{O}_2 \text{ requirement} &= 11.76 \text{ pounds/day} \\ \text{Power} &= 30 \text{ watts (see Section B-5.4)} \\ \text{O}_2 \text{ requirement} &= 13.73 \text{ pounds/day} \\ \text{Power} &= \frac{13.73}{11.76} (30) = 35 \text{ watts} \\ \text{O}_2 \text{ requirement} &= 20.06 \text{ pounds/day} \\ \text{Power} &= \frac{20.06}{11.76} (30) = 51 \text{ watts} \end{aligned}$$

B-6.4.5 SUBCRITICAL STORAGE FOR USE WITH ELECTRODIALYSIS

$$\begin{aligned}
 \text{O}_2 \text{ requirement} &= 11.76 \text{ pounds/day} \\
 \text{Power} &= \frac{8.06}{11.76} (30) = 20 \text{ watts} \\
 \text{O}_2 \text{ requirement} &= 13.73 \text{ pounds/day} \\
 &\quad \underline{-3.7} \text{ pounds/day of O}_2 \text{ from} \\
 &\quad \text{electrodialysis} \\
 &\quad 10.03 \text{ pounds/day of O}_2 \text{ from} \\
 &\quad \text{subcritical storage} \\
 \text{Power} &= \frac{10.03}{11.76} (30) = 25.6 \text{ watts} \\
 \text{O}_2 \text{ requirement} &= 20.06 \text{ pounds/day} \\
 &\quad \underline{-3.7} \text{ pounds/day of O}_2 \text{ from} \\
 &\quad \text{electrodialysis} \\
 &\quad 16.36 \text{ pounds/day of O}_2 \text{ from} \\
 &\quad \text{subcritical storage} \\
 \text{Power} &= \left(\frac{16.36}{11.76} \right) (30) = 41.8 \text{ watts}
 \end{aligned}$$

B-6.4.6 MOLECULAR SIEVE FOR USE WITH SUBCRITICAL STORAGE

	With Thermal Integration		No Thermal Integration	
	Weight (pounds)	Power (watts)	Weight (pounds)	Power (watts)
CO ₂ removal	107	100	107	100
Heat source (at 30 lb/kw)	<u>8</u>	<u>-</u>	<u>0</u>	<u>268</u>
	115	100	107	368

B-6.4.7 SOLID AMINE FOR USE WITH SUBCRITICAL STORAGE

$$\begin{aligned}
 \text{Assume vacuum blower} &= 5 \text{ pounds} \\
 \text{Assume CO}_2 \text{ storage tank} &= \underline{8} \text{ pounds} \\
 &13 \text{ pounds} \\
 158 \text{ pounds} & \quad 307 \text{ watts (see Section} \\
 & \quad \text{B-5.1.3)} \\
 \underline{-13 \text{ pounds}} & \quad \underline{-240 \text{ watts}} \text{ (blower)} \\
 145 \text{ pounds} & \quad 67 \text{ watts} \\
 149 \text{ pounds} & \quad 639 \text{ watts} \\
 \underline{-13 \text{ pounds}} & \quad \underline{-240 \text{ watts}} \\
 136 \text{ pounds} & \quad 399 \text{ watts}
 \end{aligned}$$

B-6.4.8 ELECTRODIALYSIS FOR USE WITH SUBCRITICAL STORAGE

Electrodialysis concept will not require CO₂ tank.

94 pounds (see Table B-2)
-8 pounds assumed weight of CO₂ tank
 86 pounds

B-6.4.9 BOSCH FOR USE WITH ELECTRODIALYSIS

O₂ requirement = 11.76 pounds/day

-3.7 pounds/day of O₂ from electrodialysis unit
 8.06 pounds/day of O₂ from water electrolysis unit

Bosch concept itemized in Table B-4 will be reduced as follows:

$$\frac{8.06}{11.76} = 0.686$$

$$(0.686)(2080 \text{ watts}) = 1426 \text{ watts}$$

$$(0.686)(92 \text{ pounds electrolysis unit and blower}) = 63 \text{ pounds}$$

	Weight (pounds)	Power (watts)
Electrolysis unit and blower	63	1426
Other	<u>114</u>	<u>535</u>
	183	1961

O₂ requirement = 13.73 pounds/day

-3.7 pounds/day of O₂ from
 electrodialysis unit

10.03 pounds

Bosch concept will be same as shown in Table B-4 except that water electrolysis unit will be sized for 10.03 pounds/day of O₂.

$$(7.82)(10.03) = 78 \text{ pounds}$$

$$(177)(10.03) = 1776 \text{ watts}$$

	Weight (pounds)	Power (watts)
Electrolysis unit	78	1776
Other	<u>122</u>	<u>535</u>
	200	2311

O₂ requirement = 20.06 pounds/day
 -3.7 pounds/day of O₂ from
 electrodialysis unit
 16.36 pounds/day of O₂ must come
 from water electrolysis unit

(7.82)(16.36) = 128 pounds

(177)(16.36) = 2893 watts

	Weight (pounds)	Power (watts)
Electrolysis unit	128	2893
Other	<u>122</u>	<u>535</u>
	250	3428

B-6.4.10 SABATIER FOR USE WITH ELECTRODIALYSIS

O₂ requirement = 11.76 pounds/day
 -3.7 pounds/day of O₂ from
 electrodialysis unit
 8.06 pounds/day of O₂ must come
 from water electrolysis unit

(7.82)(8.06) = 63 pounds

(177)(8.06) = 1425 watts

	Weight (pounds)	Power (watts)
Electrolysis unit	63	1425
Other	<u>17</u>	<u>30</u>
	80	1455

O₂ requirement = 13.73 pounds/day
 -3.7 pounds/day of O₂ from
 electrodialysis unit
 10.03 pounds/day of O₂ must come from
 water electrolysis unit

(7.82)(10.03) = 78.5 pounds

(177)(10.03) = 1776 watts

	Weight (pounds)	Power (watts)
Electrolysis unit	78.5	1776
Other	<u>17</u>	<u>30</u>
	95.5	1806

O_2 requirement = 20.06 pounds/day
 $\underline{-3.7}$ pounds/day of O_2 from
 electro dialysis unit
 16.36 pounds/day of O_2 must come from
 water electrolysis unit

 (7.82)(16.36) = 127.8 pounds
 (177)(16.36) = 2894 watts

	Weight (pounds)	Power (watts)
Electrolysis unit	127.8	2894
Other	<u>17</u>	<u>30</u>
	144.8	2924

B-6.4.11 SOLID ELECTROLYTE FOR USE WITH ELECTRODIALYSIS

O_2 requirement = 11.76 pounds/day
 - electro dialysis produces 0.268 lb O_2 /lb CO_2
 - For solid electrolyte, 1.173 pound CO_2 gives 0.853 pound O_2 and
 0.147 pound O_2 is makeup by electrolysis.

For every pound of CO_2 removed, cabin must be resupplied with 0.852 pound O_2 .

0.852
 $\underline{-0.268}$ from electro dialysis
 0.584 pound O_2 must be obtained from solid electrolyte
 for each pound CO_2 removed from cabin

 (0.584 pound CO_2) $\frac{44}{32}$ = 0.804 pound CO_2

Thus, for this combination, the solid electrolyte O_2 recovery system need only reclaim the O_2 from 0.804 of every pound of CO_2 removed from cabin.

284 pounds weight of solid electrolyte system
 $\underline{-14}$ pounds weight of electrolysis unit not needed at all
 270 pounds
 x0.804 pounds
 217 pounds
 2236 watts
 $\underline{-306}$ watts
 1930 watts
 x0.804
1550 watts

O_2 requirement = 13.73 pounds/day
-3.7 pounds/day of O_2 from
 electro dialysis
 10.03 pounds/day of O_2 must come from
 solid electrolyte

This is O_2 rate provided by reducing all CO_2 , and thus solid electrolyte concept requires no electrolysis unit.

284 pounds (see Table B-6)	2236 watts
<u>-14</u> pounds (electrolysis unit)	<u>-306</u> watts
270 pounds	1930 watts

O_2 requirement = 20.06 pounds/day
-3.7 pounds/day of O_2 from
 electro dialysis
 16.36 pounds/day of O_2 must come from
 solid electrolyte
-10.03 pounds/day of O_2 available
 from CO_2
 6.33 pounds/day of O_2 must come from
 makeup water

(7.82)(6.33) = 49.5 pounds

(177)(6.33) = 1120 watts

270 pounds	1930 watts
<u>49.5</u> pounds	<u>1120</u> watts
319.5 pounds	3050 watts

Weight and power summaries of the various combinations are given in Tables B-10 through B-13.

Table B-10: COMBINATIONS USING BOSCH--WEIGHT AND POWER

Oxygen Requirement (pounds/day)	Combined Concept	With Thermal Integration		No Thermal Integration	
		Weight (pounds)	Power (watts)	Weight (pounds)	Power (watts)
11.76	Bosch	214	2615	214	2615
	Molecular Sieve	<u>154</u>	<u>115</u>	<u>115</u>	<u>1400</u>
		368	2730	329	4015
13.73	Bosch	229.3	2965	229.3	2965
	Molecular Sieve	<u>154</u>	<u>115</u>	<u>115</u>	<u>1400</u>
		383.3	3080	344.3	4365
20.06	Bosch	279	4085	279	4085
	Molecular Sieve	<u>154</u>	<u>115</u>	<u>115</u>	<u>1400</u>
		433	4200	394	5485
11.76	Bosch	214	2615	214	2615
	Solid Amine	<u>158</u>	<u>307</u>	<u>149</u>	<u>639</u>
		372	2922	363	3254
13.73	Bosch	229.3	2965	229.3	2965
	Solid Amine	<u>158</u>	<u>307</u>	<u>149</u>	<u>639</u>
		387.3	3272	378.3	3604
20.06	Bosch	279	4085	279	4085
	Solid Amine	<u>158</u>	<u>307</u>	<u>149</u>	<u>639</u>
		437	4392	428	4724
11.76	Bosch	185	1961	185	1961
	Electrodialysis	<u>94</u>	<u>849</u>	<u>94</u>	<u>849</u>
		279	2810	279	2810
13.73	Bosch	200	2311	200	2311
	Electrodialysis	<u>94</u>	<u>849</u>	<u>94</u>	<u>849</u>
		294	3160	294	3160
20.06	Bosch	250	3428	250	3428
	Electrodialysis	<u>94</u>	<u>849</u>	<u>94</u>	<u>849</u>
		344	4277	344	4277

Table B-11: COMBINATIONS USING SABATIER--WEIGHT AND POWER

Oxygen Requirement (pounds/day)	Combined Concept	With Thermal Integration		No Thermal Integration	
		Weight (pounds)	Power (watts)	Weight (pounds)	Power (watts)
11.76	Sabatier	109	2110	109	2110
	Molecular Sieve	<u>154</u>	<u>115</u>	<u>115</u>	<u>1400</u>
		263	2225	224	3510
13.73	Sabatier	124.3	2460	124.3	2460
	Molecular Sieve	<u>154</u>	<u>115</u>	<u>115</u>	<u>1400</u>
		278.3	2575	239.3	3860
20.06	Sabatier	174	3580	174	3580
	Molecular Sieve	<u>154</u>	<u>115</u>	<u>115</u>	<u>1400</u>
		328	3695	289	4980
11.76	Sabatier	109	2110	109	2110
	Solid Amine	<u>158</u>	<u>307</u>	<u>149</u>	<u>639</u>
		267	2417	258	2749
13.73	Sabatier	124.3	2460	124.3	2460
	Solid Amine	<u>158</u>	<u>307</u>	<u>149</u>	<u>639</u>
		282.3	2767	273.3	3099
20.06	Sabatier	174	3580	174	3580
	Solid Amine	<u>158</u>	<u>307</u>	<u>149</u>	<u>639</u>
		332	3887	323	4219
11.76	Sabatier	80	1455	80	1455
	Electrodialysis	<u>94</u>	<u>849</u>	<u>94</u>	<u>849</u>
		174	2304	174	2304
13.73	Sabatier	95.5	1806	95.5	1806
	Electrodialysis	<u>94</u>	<u>849</u>	<u>94</u>	<u>849</u>
		189.5	2655	189.5	2655
20.06	Sabatier	144.8	2924	144.8	2924
	Electrodialysis	<u>94</u>	<u>849</u>	<u>94</u>	<u>849</u>
		238.8	3773	238.8	3773

Table B-12: COMBINATIONS USING SOLID ELECTROLYTE--WEIGHT AND POWER

Oxygen Requirement (pounds/day)	Combined Concept	With Thermal Integration		No Thermal Integration	
		Weight (pounds)	Power (watts)	Weight (pounds)	Power (watts)
11.76	Solid Electrolyte	284	2236	284	2236
	Molecular Sieve	<u>154</u>	<u>115</u>	<u>115</u>	<u>1400</u>
		438	2351	399	3636
13.73	Solid Electrolyte	298.9	2585	298.9	2585
	Molecular Sieve	<u>154</u>	<u>115</u>	<u>115</u>	<u>1400</u>
		452.9	2700	413.9	3985
20.06	Solid Electrolyte	348.5	3706	348.5	3706
	Molecular Sieve	<u>154</u>	<u>115</u>	<u>115</u>	<u>1400</u>
		502.5	3821	463.5	5106
11.76	Solid Electrolyte	284	2236	284	2236
	Solid Amine	<u>158</u>	<u>307</u>	<u>149</u>	<u>639</u>
		442	2543	433	2875
13.73	Solid Electrolyte	298.9	2585	298.9	2585
	Solid Amine	<u>158</u>	<u>307</u>	<u>149</u>	<u>639</u>
		456.9	2892	447.9	3224
20.06	Solid Electrolyte	348.5	3706	348.5	3706
	Solid Amine	<u>158</u>	<u>307</u>	<u>149</u>	<u>639</u>
		506.5	4013	497.5	4345
11.76	Solid Electrolyte	218	1550	218	1550
	Electrodialysis	<u>94</u>	<u>849</u>	<u>94</u>	<u>849</u>
		312	2399	312	2399
13.73	Solid Electrolyte	270	1930	270	1930
	Electrodialysis	<u>94</u>	<u>849</u>	<u>94</u>	<u>849</u>
		364	2779	364	2779
20.06	Solid Electrolyte	319.5	3050	319.5	3050
	Electrodialysis	<u>94</u>	<u>849</u>	<u>94</u>	<u>849</u>
		413.5	3899	413.5	3899

Table B-13: COMBINATIONS USING SUBCRITICAL STORAGE--WEIGHT AND POWER

Oxygen Requirement (pounds/day)	Combined Concept	With Thermal Integration		No Thermal Integration	
		Weight (pounds)	Power (watts)	Weight (pounds)	Power (watts)
11.76	Subcritical Storage	---	30	---	30
	Molecular Sieve	<u>115</u>	<u>100</u>	<u>107</u>	<u>368</u>
		115	130	107	398
13.73	Subcritical Storage	---	35	---	35
	Molecular Sieve	<u>115</u>	<u>100</u>	<u>107</u>	<u>368</u>
		115	135	107	403
20.03	Subcritical Storage	---	51	---	51
	Molecular Sieve	<u>115</u>	<u>100</u>	<u>107</u>	<u>368</u>
		115	151	107	419
11.76	Subcritical Storage	---	30	---	30
	Solid Amine	<u>145</u>	<u>67</u>	<u>136</u>	<u>399</u>
		145	97	136	429
13.73	Subcritical Storage	---	35	---	35
	Solid Amine	<u>145</u>	<u>67</u>	<u>136</u>	<u>399</u>
		145	102	136	434
20.06	Subcritical Storage	---	51	---	51
	Solid Amine	<u>145</u>	<u>67</u>	<u>136</u>	<u>399</u>
		145	118	136	450
11.76	Subcritical Storage	---	20	---	20
	Electrodialysis	<u>86</u>	<u>849</u>	<u>86</u>	<u>849</u>
		86	869	86	869
13.73	Subcritical Storage	---	25.6	---	25.6
	Electrodialysis	<u>86</u>	<u>849</u>	<u>86</u>	<u>849</u>
		86	874.6	86	890.8
20.06	Subcritical Storage	---	41.8	--	41.8
	Electrodialysis	<u>86</u>	<u>849</u>	<u>86</u>	<u>849</u>
		86	890.8	86	890.8

B-6.5 WEIGHT AND POWER FOR MOLTEN ELECTROLYTE

O_2 requirement = 11.76 pounds/day (see Section B-5.3 for details)

O_2 requirement = 13.73 pounds/day

-10.03 pounds/day of O_2 from CO_2

3.7 pounds/day of O_2 must come from water electrolysis unit

0.5 instrumentation + 7.82(3.7) = 0.5 + 28.9
and controls

= 29.4 pounds

177(3.7) = 655 watts

	Weight (pounds)	Power (watts)
Molten electrolysis unit and associated equipment	260	1080
Water electrolysis unit and instrumentation and controls	<u>29.4</u>	<u>655</u>
	289.4	1735

Identical for case of no thermal integration

O_2 requirement = 20.06 pounds/day

-10.03 pounds/day of O_2 from CO_2

10.03 pounds/day of O_2 must come from water electrolysis unit

0.5 instrumentation + 7.82(10.03) = 0.5 + 78.5
and controls = 79 pounds

177(10.03) = 1776 watts

	Weight (pounds)	Power (watts)
Molten electrolysis unit and associated equipment	260	1080
Water electrolysis unit and instrumentation and controls	<u>79</u>	<u>1776</u>
	339	2856

Identical for case of no thermal integration.

Table B-14: FIXED WEIGHT AND POWER FOR ECS COMBINATIONS

	$O_2 = 11.76 \text{ lb/day}$						$O_2 = 13.73 \text{ lb/day}$						$O_2 = 20.06 \text{ lb/day}$							
	With Thermal Integration			No Thermal Integration			With Thermal Integration			No Thermal Integration			With Thermal Integration			No Thermal Integration				
	Weight	Power		Weight	Power		Weight	Power		Weight	Power		Weight	Power		Weight	Power			
	lb	watts	lb	watts	lb	lb	watts	lb	watts	lb	watts	lb	watts	lb	watts	lb	watts	lb	watts	
CO_2 Removal																				
	O ₂ Supply																			
Molecular Sieve	368	2730	329	4015	383.3	3080	344.3	4365	433	4200	394	5485								
Molecular Sieve	263	2225	224	3510	278.3	2575	239.3	3860	328	3695	289	4980								
Molecular Sieve	438	2351	399	3636	452.9	2700	413.9	3985	502.5	3821	463.5	5106								
Molecular Sieve	115	130	107	398	115	135	107	403	115	151	107	419								
Solid Amines	372	2922	363	3254	387.3	3272	378.3	3604	437	4392	428	4724								
Solid Amines	267	2417	258	2749	282.3	2767	273.3	3099	332	3887	323	4219								
Solid Amines	442	2543	433	2875	456.9	2892	447.9	3224	506.5	4013	497.5	4345								
Solid Amines	145	97	136	429	145	102	136	434	145	118	136	450								
Electrodialysis	279	2810	279	2810	294	3160	294	3160	344	4277	344	4277								
Electrodialysis	174	2304	174	2304	189.5	2655	189.5	2655	238.8	3773	238.8	3773								
Electrodialysis	312	2399	312	2399	364	2779	364	2779	413.5	3899	413.5	3899								
Electrodialysis	86	869	86	869	86	874.6	86	874.6	86	890.8	86	890.8								
Molten Electrolyte	274	1386	274	1386	289.4	1735	289.4	1735	339	2856	339	2856								

B-7.0 ESTIMATED COSTS

Environmental control subsystem costs were estimated according to the ground rules stated in Section B-7.1. Costs are shown on Table B-15.

B-7.1 COSTING GROUND RULES AND ASSUMPTIONS

Costs shown are for the CO₂ removal equipment and O₂ supply equipment only and are not intended to represent the costs of complete ECS systems.

All costs are shown in 1967 dollars and include fees.

R&D costs include three test articles.

Spares cost per pound was developed as follows:

$$\frac{\text{Total First Unit Cost}}{\text{Fixed Weight (pounds)}} = \text{Spares Dollars per Pound}$$

Technology development cost is that associated with the development of a concept, whereas the R&D cost represents the development of the system after the concept has proven feasible.

Costs have not been included to integrate the ECS subsystem components into a complete subsystem.

Table B-15: ESTIMATED COSTS FOR ENVIRONMENTAL CONTROL SUBSYSTEM CONCEPTS

Concept		Nonrecurring Cost (millions of dollars)		Recurring Cost (millions of dollars First Unit)	Spares Cost No. 1 (dollars/ pound)
		Technology	R&D		
Bosch--Molecular Sieve		-0-	15.100	1.307	4,300
Bosch--Solid Amines		-0-	16.400	1.487	4,400
Bosch--Electrodialysis		-0-	14.625	1.237	4,686
Sabatier--Molecular Sieve		-0-	11.750	.815	3,900
Sabatier--Solid Amines		-0-	13.000	.984	4,050
Sabatier--Electrodialysis		-0-	11.400	.782	4,750
Solid Electrolyte--Molecular Sieve		-0-	17.600	1.728	4,500
Solid Electrolyte--Solid Amines		-0-	19.800	1.923	4,600
Solid Electrolyte--Electrodialysis		-0-	17.000	1.701	5,469
Molten Electrolyte		-	14.072	1.144	4,175
Subcritical Storage-- Molecular Sieve	National Space Station	-0-	8.400	.750	370
	Venus Mission	-0-	6.400	.425	530
	Mars Mission	-0-	6.700	.475	500
Subcritical Storage-- Solid Amines	National Space Station	-0-	8.700	.805	390
	Venus Mission	-0-	6.500	.440	525
	Mars Mission	-0-	6.800	.485	490
Subcritical Storage-- Electro- dialysis	National Space Station	-0-	8.400	.750	370
	Venus Mission	-0-	6.400	.425	530
	Mars Mission	-0-	6.700	.470	500

B-8.0 DEVELOPMENT STATUS

Below is a summary of the development status of the concepts considered in this study.

Molecular Sieves (CO₂ Removal)

- Under development since 1958
- At least five prototype models constructed by Hamilton Standard
- Boeing-constructed unit tested by the Air Force for 30 days
- Included as part of Langley life-support system
- Other units constructed by AiResearch, Thompson Ramo Wooldridge, Incorporated (TRW), and General American Transportation Corporation (GATC)

Solid Amines (CO₂ Removal)

- Two-man model constructed by GATC
- Research being conducted by GATC for application in submarines

Electrodialysis (CO₂ Removal)

- Ionics, Incorporated, has received at least four contracts from various government agencies
 - Bureau of Ships, 1963
 - Air Force Aeronautical Systems Division for a laboratory model
 - Bureau of Ships, 1964, 10-man prototype unit
 - NASA Manned Spacecraft Center, 1963, four-man prototype system
- Ionics believes that the electrodialysis stack is capable of operating for 3 years without failure
- Zero "g" liquid-gas separators require development

Bosch (CO₂ Reduction)

- Three-man unit developed by GATC in 1961-62 for the Aerospace Medical Division, USAF
- One-half man unit fabricated and tested by TRW under Contract NASw-650
- Four-man unit developed by GATC for Langley Life Support System
- Problems requiring prime consideration are:

- determination of a suitable catalyst and catalyst configuration,
- method for removing carbon from the reactor, and
- development of a compact, efficient, and reliable water electrolysis unit.

Sabatier (CO₂ Reduction)

- Boeing (water electrolysis not designed for 0 gravity operation):
 - 25-day continuous run with simulated three-man crew,
 - 2-day, two-men test,
 - three-men, 30-day test conducted by the Air Force in 1963
- Sabatier reactor is used as a backup to the Bosch reactor in the Langley Life Support System
- AiResearch under Air Force contract evaluated catalysts
- GATC under Air Force contract evaluated catalysts
- Hamilton Standard is constructing a one-man unit under Air Force Contract (\$460,000)
- Development of a compact, efficient, and reliable water electrolysis unit is the prime problem. Development of a method to reduce the amount of expendables required is an additional problem. However, this study was not based on a reduction in expendables.

Solid Electrolyte (CO₂ Reduction)

- Isomet built a one-man unit for the Aerospace Medical Research Laboratory
- Isomet built a flyable version (about one-tenth man capacity) for test under simulated flight conditions
- Designated as an Air Force experiment
- The major problems requiring development include: a high temperature fan and motor, carbon removal, and capability to withstand shock and vibration loads.

Molten Electrolyte (CO₂ Reduction)

- Still in the research stage
- Hamilton Standard has received a minimum of \$250,000 from NASA for development.

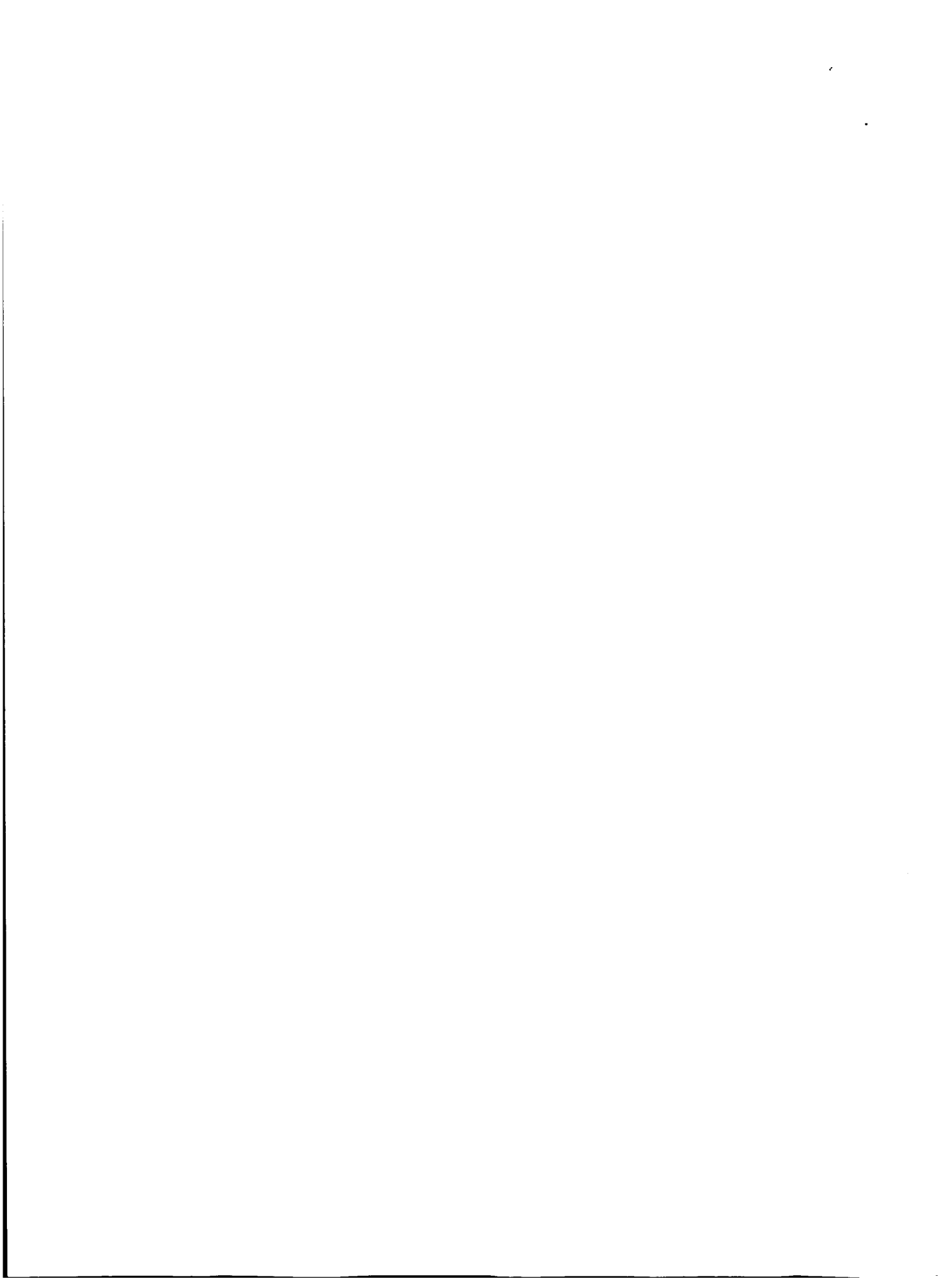

D2-113544-6

PRECEDING PAGE BLANK NOT FILMED.

APPENDIX C

STUDY OF THE COMMUNICATIONS SUBSYSTEM

CONTENTS

	<u>Page</u>
C-1.0 SCOPE AND DEFINITION	183
C-2.0 GROUND RULES AND ASSUMPTIONS	183
C-3.0 CONCEPTS INVESTIGATED	183
C-4.0 METHOD OF COMPARING CONCEPTS	183
C-4.1 Comparison of Laser to Radio Frequency	183
C-4.2 Comparison of RF Subsystems	183
C-5.0 DESCRIPTION AND DISCUSSION OF COMMUNICATION CONCEPTS	186
C-5.1 Laser Communications	186
C-5.1.1 Discussion of Laser Types	186
C-5.1.2 Parameters	186
C-5.1.3 Laser Communication Subsystem Description	187
C-5.1.4 Laser Ground System	187
C-5.2 Radio Frequency Communications Subsystems	190
C-5.2.1 Engineering Analysis	191
C-5.2.2 Typical Subsystem Descriptions	195
C-6.0 ANTENNA AND TRANSMITTER POWER AMPLIFIER COSTS	210

C-1.0 SCOPE AND DEFINITION

The communications subsystem equipment studied includes only the spacecraft transmitter (power amplifier) and the antenna and antenna drive. For the laser subsystem discussed, the equipment considered is that assumed to perform equivalent functions. Both the laser concept and the radio frequency communications concept are discussed in Section C-5.0. Section C-5.1 discusses laser systems, and RF communications are discussed in Section C-5.2.

C-2.0 GROUND RULES AND ASSUMPTIONS

As a departure from the other subsystems studied in this document, it is assumed that communications from Earth orbit present no problem. Therefore, this portion of the study concentrates on deep space communications. Other necessary assumptions are indicated where necessary throughout this appendix.

C-3.0 CONCEPTS INVESTIGATED

While there are other methods of communication from deep space, it is easily argued that the only practical concepts are RF communications and laser* communications. One point to be investigated is, therefore, the choice between these two concepts. Under some conditions RF communications are unquestionably more desirable and cost effective than laser communications. In this case there is another trade to be made: that is the trade between antenna gain (size) and transmitter (power amplifier) power. There are other subtrades to be made, such as those between the different methods of modulating the transmitter carrier; however, these trades are not further considered in this work.

C-4.0 METHOD OF COMPARING CONCEPTS

C-4.1 COMPARISON OF LASER TO RADIO FREQUENCY

Because of the performance capabilities of the laser concept, it is extremely difficult to compare it to RF systems in terms of cost at a point of equal performance. Therefore, comparison of laser to RF is made in terms of performance. This comparison is provided in Section 7.3 of the basic document.

C-4.2 COMPARISON OF RF SUBSYSTEMS

For some fixed spacecraft radiated power requirement, there are virtually unlimited combinations of antenna gain and transmitter power that will satisfy the requirement. It is also intuitively obvious that the cost of an antenna will increase with gain (size) and the cost of the transmitter power amplifier will increase with RF power output. Because the elements are inversely related for a fixed effective radiated power (ERP) it can be assumed that there is some cost-optimum choice of antenna and transmitter. The determination of the optimum relationship for a series of interplanetary

*Laser-Light Amplification by Stimulated Emission of Radiation

flights is complicated by necessity of penalizing the combination for weight and the electrical power required.

Parametric cost curves were developed for a program of four interplanetary flights. This was done by determining the total flight program cost of several antenna transmitter combinations that would result in a fixed ERP. In this way, a curve of total flight program cost versus antenna gain and transmitter power could be drawn. This was done for ERP's ranging from 40 to 90 dbm.* The result is shown as Figure 7.3-2 in the basic document. Cost, weight, power, and gain for the antenna/transmitter combinations were derived from the material provided in Section C-5.2. A tabulation of the combinations analyzed is provided as Table C-1. These combinations were evaluated with the elementary cost program below.

$$C_t = C_{rec} + C_d + C_{acc}$$

where

C_t is total flight program cost (four missions)

and

C_{rec} = recurring cost

C_d = R&D cost (total for antenna and transmitter)

C_{acc} = acceleration cost

$$C_{rec} = 4 \times (C_{at} + P \times C_p)$$

where

C_{at} is the unit cost of antenna and transmitter

and

P = primary power required by the transmitter

C_p = cost of power in dollars/watt

$$C_{acc} = 4 \times C_4 \times (W + P \times P_p)$$

where

C_4 = mission acceleration cost in dollars/pound

and

W = total weight of antenna and transmitter

P_p = power penalty in pounds/watt

*dbm = decibels above a 1 milliwatt reference level.

Table C-1: COMMUNICATIONS COST PROGRAM INPUT DATA POINTS

ERP in dbm	Weight (lb)	Power (watts)	Unit Cost (\$ x 10 ³)	R&D Cost (\$ x 10 ³)	G ₀ (db)
40	7.5	2.0	61.0	725.0	23.5
	10.5	2.0	74.0	840.0	27.0
	38.5	2.0	160.0	1530.0	30.2
	158.5	2.0	372.0	3100.0	37.0
	290.5	2.0	540.0	4470.0	39.9
	392.5	2.0	650.0	5300.0	47.0
	50	Essentially the same as 40			
60	9.0	36.0	61.0	745.0	23.5
	11.0	17.0	74.0	840.0	27.0
	39.0	10.0	160.0	1530.0	30.2
	158.5	2.0	372.0	3100.0	37.0
	290.5	2.0	540.0	4470.0	39.9
	392.5	2.0	650.0	5300.0	47.0
	70	18.0	342.0	65.5	955.0
15.5		168.0	74.5	962.0	27.0
41.0		96.0	160.0	1603.0	30.2
159.0		22.0	372.0	3100.0	37.0
291.0		15.0	540.0	4470.0	39.9
393.0		3.0	650.0	5300.0	47.0
80		93.0	3480.0	133.0	3425.0
	52.0	1680.0	102.0	1690.0	27.0
	62.5	945.0	175.0	2030.0	30.2
	165.0	222.0	373.8	3260.0	37.0
	295.0	147.0	540.0	4580.0	39.9
	393.0	30.0	650.0	5300.0	47.0
	90	207.0	9450.0	1200.0	35000.0
214		2220.0	411.0	4270.0	37.0
330.0		1570.0	564.0	5220.0	39.9
440.0		300.0	653.5	550.0	47.0

C-5.0 DESCRIPTION AND DISCUSSION OF COMMUNICATION CONCEPTS

Section C-5.1 discusses laser communications and describes a typical laser communications subsystem. Radio frequency communications are discussed in Section C-5.2 where several subsystems of different capabilities are described.

C-5.1 LASER COMMUNICATIONS

For most subsystems there is generally a fixed requirement, based on the mission under consideration, which can be used as the design point in trade studies. This is not true for space vehicle-to-Earth communications. The data transmission requirements necessary to crew survival, vehicle systems operation, and planned flight path can be reasonably well-defined. On the other hand, the data transmission requirements applicable to mission experiments and to the somewhat subjective desires of mission controllers, the scientific community, government, and the general public, to be apprised in near real-time of "what's going on up there," cannot be determined so readily.

A data transmission rate of 90,000 bps will handle all mandatory communications and is within the capability of proposed RF communications. It is in the area of real-time TV that the laser comes into consideration. Apollo-quality TV requires about 1 million bps. Real-time, high-quality color TV will require a data transmission rate of approximately 5.5 million bps.

Since the development of lasers for deep space communications will probably be driven by decisions to require real-time TV, 5.5 million bps should be selected as the design point for a laser communications subsystem for manned planetary missions.

C-5.1.1 DISCUSSION OF LASER TYPES

There are a number of possible lasers to consider. The two most obvious categories for current and near-future exploitation are visible and infrared systems. Visible (argon-helium-neon) lasers are at a fairly advanced state of development; however, their present efficiencies are low (0.1%) (Reference 47). The infrared CO₂ laser has demonstrated efficiencies greater than 25% and has less stringent pointing requirements; however, it is not as far advanced in development as the visible lasers.

C-5.1.2 PARAMETERS

The mission environment dictates that the design of the laser communications system must take the following into consideration:

- Range (Spacecraft to Earth);
- Spacecraft: Portion of weight and/or space allotted to communications system, tolerances and capabilities of the spacecraft's attitude control system, and amount of power available from the electrical power system;
- Earth's atmosphere: Portion of data transmission to and from a day-light Earth and a night-dark Earth, and effects of the atmosphere on the laser beam (refraction, cloud interference, etc.);
- Effects of range and relative velocity of spacecraft and Earth;
- Data rate (discussed earlier).

C-5.1.3 LASER COMMUNICATION SUBSYSTEM DESCRIPTION

The laser communication system described here is limited to discussion of the spacecraft-to-Earth link and its necessary parts, which are:

- Earth-based beacon transmitter telescope pointed towards the spacecraft;
- Spacecraft receiver-transmitter telescope, which uses the Earth beacon signal for tracking purposes;
- Earth-based receiver for collecting the spacecraft laser beam.

For the spacecraft laser system, a CO₂, cw, laser is chosen for the following reasons:

- Higher efficiency than visible lasers;
- Correspondence of 10.6 μ CO₂ laser to an atmospheric window;
- Pointing requirements are not as stringent;
- Day reception is not adversely affected.

The details of the spacecraft laser system and its power requirements will be dependent on development. Table C-2 is a preliminary estimate of weights and power requirements for the onboard system (Reference 47). Figure C-1 shows diagrammatically a typical arrangement of the laser equipment. The ground receiving network is estimated to require eight to ten stations (conservatively).

C-5.1.4 LASER GROUND SYSTEM

The present deep space net antennas are not suitable for receiving. Possible alternatives include adding the necessary laser reception equipment on the ground or employing Earth-orbiting satellites to receive laser and retransmit RF to ground.

Table C-2: CO₂ LASER SUBSYSTEM WEIGHT AND POWER ESTIMATES

Identification/ Nomenclature	Weight (lb)	Power (kw)	Area/* Volume	Lead Time		Cost (in millions)		Remarks
				Technology	R&D	R&D**	First Article	
10 μ Laser Assembly	30	0.002	2 ft ³					CO ₂ , cw Laser
Laser Power Supply	30	Ave 0.170	2 ft ³					
Laser Cooling System	15	0.002	15 ft ²					
10 μ Laser Modulator	2	0.001	0.03 ft ³					
Modulator Amplifier	10	Ave 0.120	0.5 ft ³					
Beam Splitter & Optical Filters	1		0.05 ft ³					Quantity 3
Fine Tracking & Comm. Receiver	8	Ave 0.003	0.05 ft ³					Quantity 2
Offset Pointing Subsystem	5	Ave 0.001	0.05 ft ³					
Fine Pointing Subsystem	5	Ave 0.001	0.05 ft ³					
Telescope Struct & Main Optics (1)	200 to 800		270 ft ³					
Telescope Torquer Servo (2)	3	0.002	0.5 ft ³					Quantity 2
Total Spares & Repair Kits	509	0.302				210.0	6.4	With 400-pound telescope
	318							500-day quantity

*enter area or volume if pertinent **including flight test

(1) Not determined. Based on OAO.

(2) Chargeable with main telescope structure

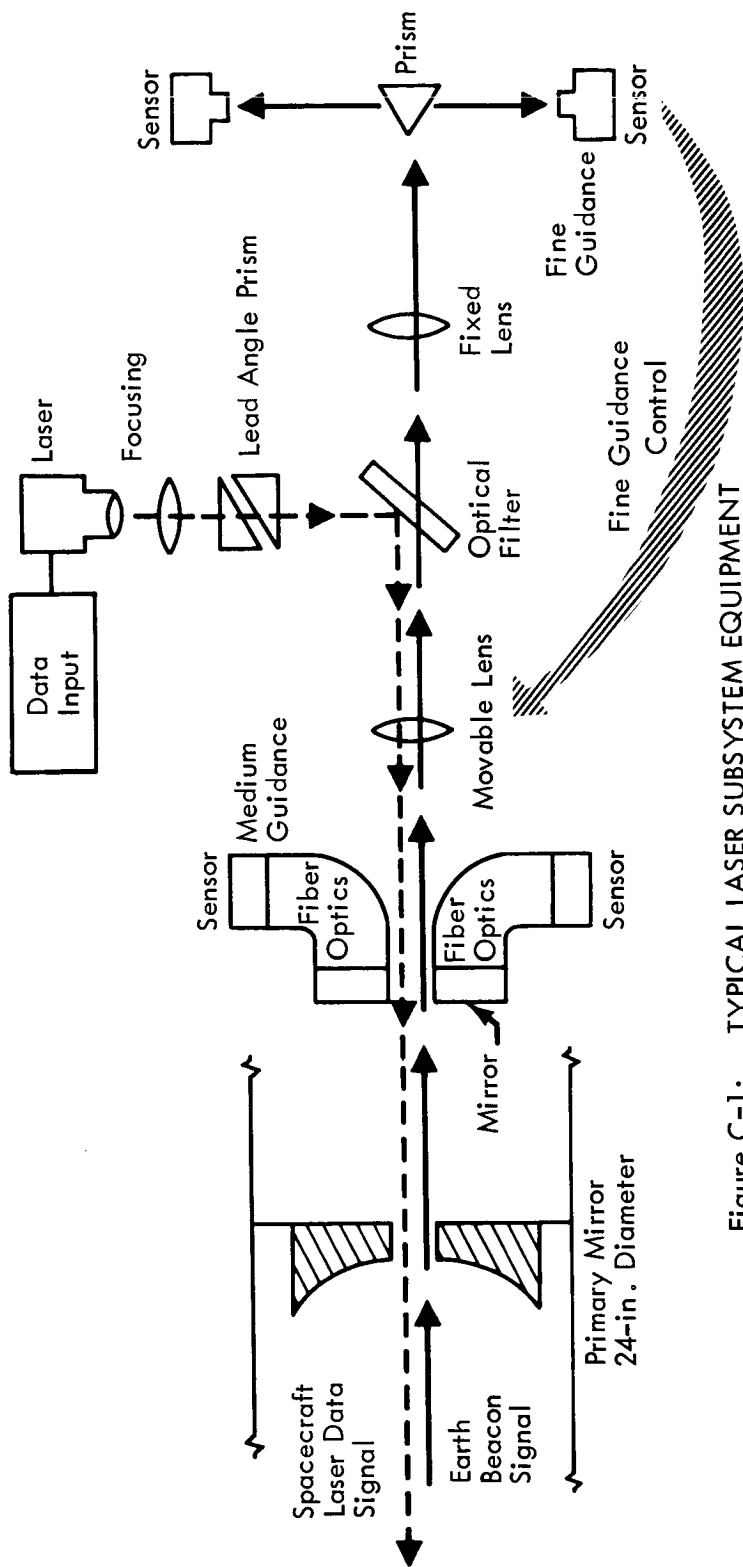
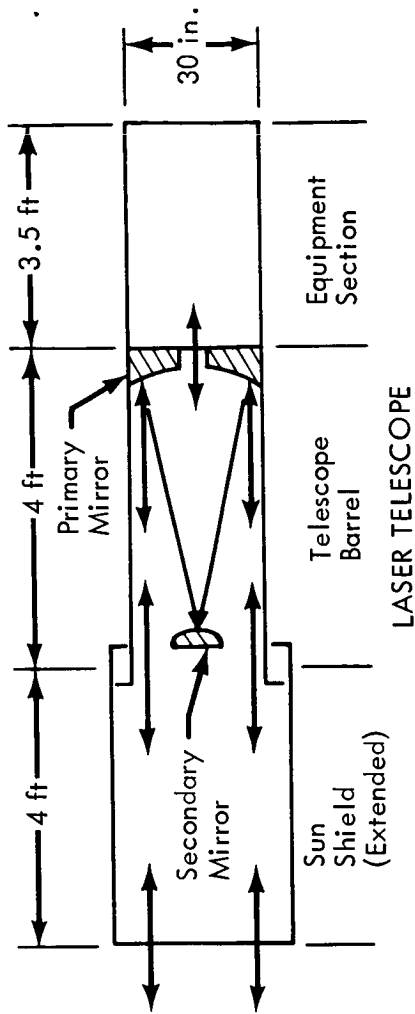

Figure C-1: TYPICAL LASER SUBSYSTEM EQUIPMENT

- 1) The ground-based laser "antenna" would provide a stable platform that would simplify pointing problems, but on the other hand, the atmospheric disturbances, such as clouds, create problems of refraction of the laser beam. Thus, a number of suitable ground stations may be necessary to increase the probability of receiving through a clear sky. (Reference 49) mentions four antennae suitably located, while other references give eight to ten.
- 2) Relay satellites would avoid the problem of transmitting laser beams through the atmosphere either by using microwave-to-ground or by utilizing laser-from-satellite over an area of Earth with clear sky, but more difficulty would be encountered in attitude stabilization and pointing.

With either method it seems that sufficient care in the planning would enable the system to be used for a wide variety of missions over a long period of time. Thus, only a portion of the cost would be levied against the proposed manned Mars and Venus missions, for which they would be originally qualified and implemented.

- 3) For a ground-based laser receiving antennae there is apparently quite a difference in the type of "antennae" required for use with the laser, depending in large part on the method of detection used (see Reference 47).

For coherent detection, apparently a diffraction-limited (i.e., very accurate, close tolerance), relatively small antenna is required.

For noncoherent detection, the receiving antenna apparently need not be as carefully made from the standpoint of fine finish and tolerances, but rather must be sufficiently large in area to gather a meaningful sample of the incoming beam to make sense of it despite the effect of atmosphere intensity fluctuations.

Although either type of antenna represents a large investment, it may be that one is much more economical than the other.

C-5.2 RADIO FREQUENCY COMMUNICATIONS SUBSYSTEMS

In this appendix section, six representative spacecraft antenna/power amplifier subsystems are defined (identified as A→F). The primary purpose in developing this information is to provide a range of capabilities against which costs can be developed. This information, combined with cost information, is used as a guide for selecting the optimal size of antenna and power amplifier for a specific mission requirement.

There are subtrades to be made in RF subsystems. These subtrades include antenna diameter versus amplifier power, and modulation techniques selection.

While it is felt that investigation of these trades is not the primary objective of the communications subsystem study, it is also obvious that the primary objective, comparison of RF and laser concepts in terms of cost and capability, cannot be accomplished without considering optimum allocation of antenna size and amplifier power.

Optimal selection of modulation type was not considered in this investigation because of the many variables that cannot be realistically specified in this study. However, expected range of performance with various types of modulation is discussed briefly in the following subsection.

It should be noted that the costs shown in this section do not give the complete cost picture. These incremental costs must be adjusted by the costs for a complete flight program including cost penalties for subsystem weight, prorated electrical power subsystem weight, and electrical power cost in order to determine total cost as the final yardstick against which the various concepts are compared.

C-5.2.1 ENGINEERING ANALYSIS

There are several parameters that can be used to compare communications systems. Among these are effective radiated power (ERP), which can be used as a measure of transmitter/antenna subsystem performance, received carrier-to-noise power density ratio (C/kT_s), which considers the transmission system, range, and receiver antenna; and transmitted data rate (bit rate) or bandwidth. For those who are not communications specialists, bit rate capability appears to have the most meaning; however, there is some difficulty in developing equivalent bit rate for analog modulation techniques that are described in terms of bandwidth. For this reason the curves of cost in terms of ERP or C/kT_s are judged to be more accurate measures of subsystem performance. Figures C-2 and C-3 indicate the relative merits of the various modulation techniques. Figure C-4 relates spacecraft ERP to the C/kT_s parameter for various transmission ranges. This information can be cross plotted with Figure C-2 to find the relationship of data rate to ERP for various transmission ranges. Such a cross plot is provided in Section 7.3.

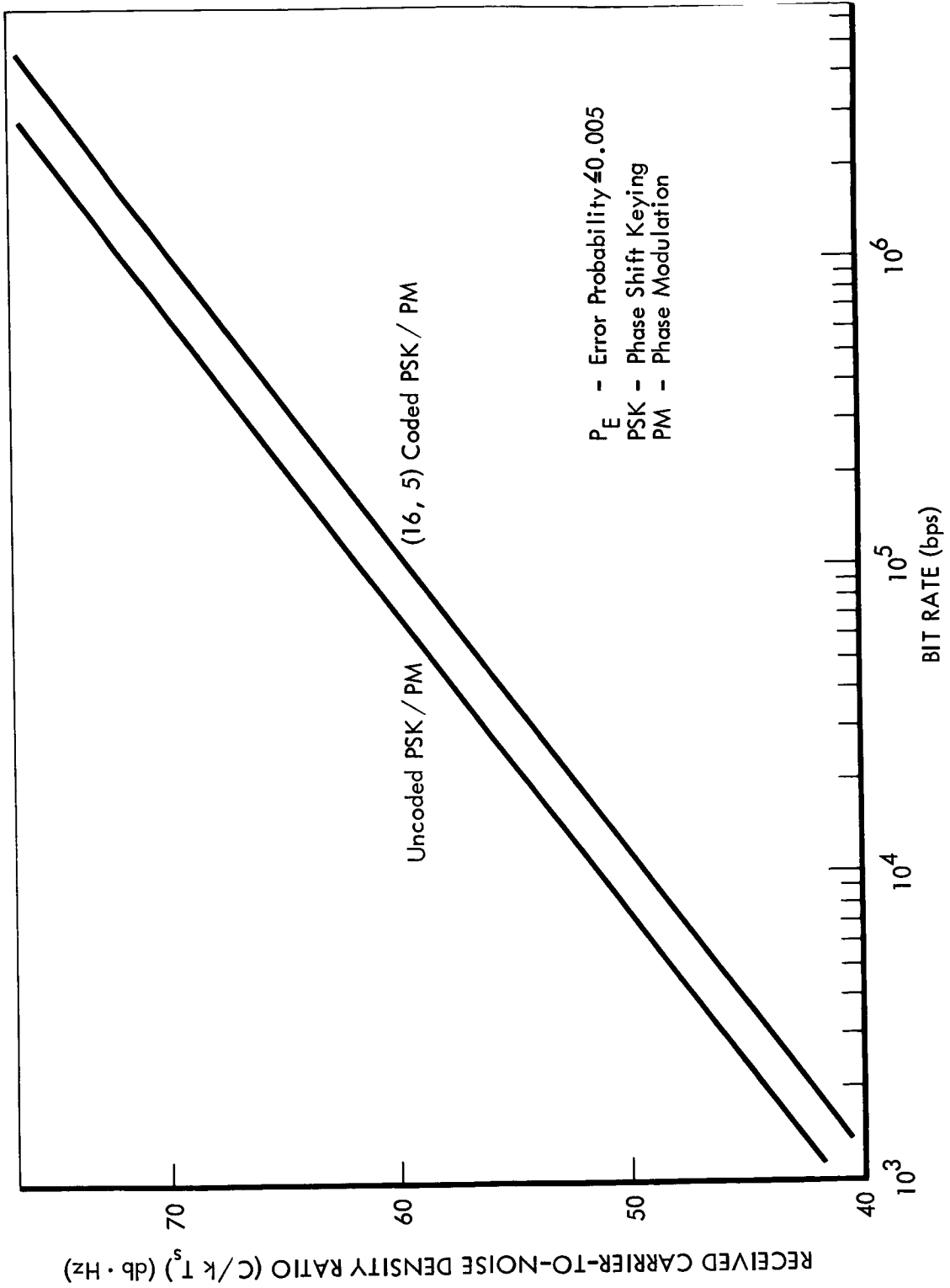
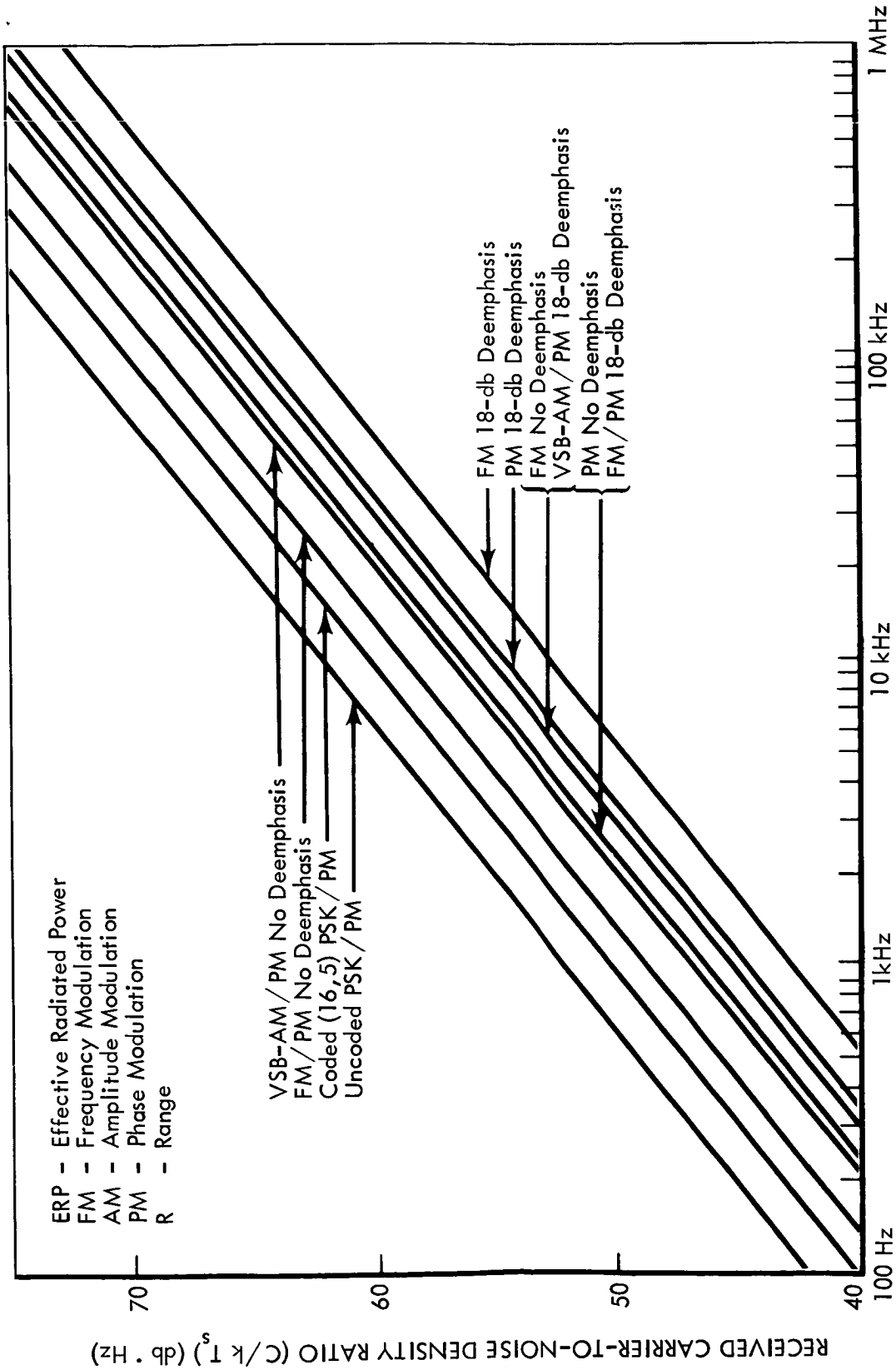

Figure C-2: BIT-RATE CAPABILITY OF DIGITAL MODULATION TECHNIQUES



AVAILABLE DATA BANDWIDTH
 Figure C-3: COMPARISON OF THE BANDWIDTH CAPABILITIES OF ANALOG AND DIGITAL MODULATION TECHNIQUES

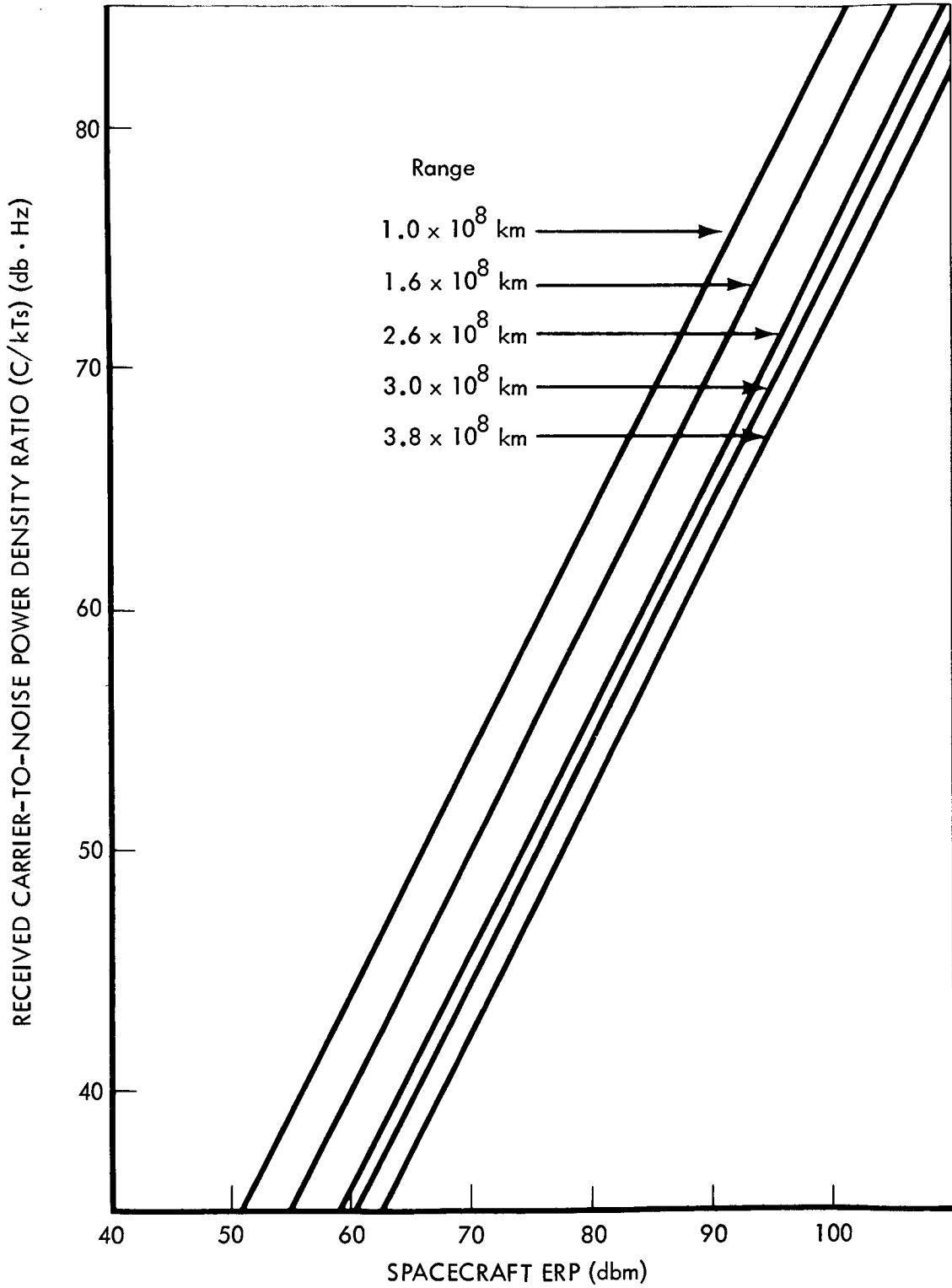

Figure C-4: SPACECRAFT-TO-EARTH LINK PERFORMANCE

Constants and Calculations--Where range is a factor, all RF communications subsystems have been normalized to a transmission range of 1 AU (assumed as 1.5×10^8 km). Parameter values not specifically covered here have been selected from one or more of References 30-34. The weights and power requirements shown on the data sheets were developed similarly.

Receiving System--The receiving antenna is assumed to be a 210-foot DSIF, S-band antenna operating at a noise temperature of 35°K. C/kT_s with a 1.5×10^8 transmission range is calculated to be $ERP - 20 \log(R) + 144.1$.

Transmitting System

$$ERP = P_t + G_t - L_{rf}$$

where

P_t = power amplifier output in dbm (decibels referred to a milliwatt)

G_t = net antenna gain

$$= G_o - L_p$$

G_o = antenna gain = $14.3 + 20 \log(D)$

where

D = antenna diameter in feet

L_p = pointing losses

L_{rf} = RF circuit losses in the spacecraft = 4.2 db (Reference 30)

The pointing error (per axis) is assumed to be $\pm 0.35^\circ = O_E$ for all subsystems except C, which requires more accurate pointing to minimize losses. The pointing error losses in db are determined from Figure C-5.

C-5.2.2 TYPICAL SUBSYSTEM DESCRIPTIONS

A space communications subsystem is functionally depicted by Figure C-6. For the purposes of this study, only the spacecraft antenna and transmitter power amplifier are considered. Six different combinations of antenna and power amplifier are described in Tables C-3 through C-14. The first table of each pair summarizes the RF characteristics of the subsystem described, and shows an analysis of the RF link. Each of the subsystems described was derived from a documented source or sources which are indicated by reference notes.

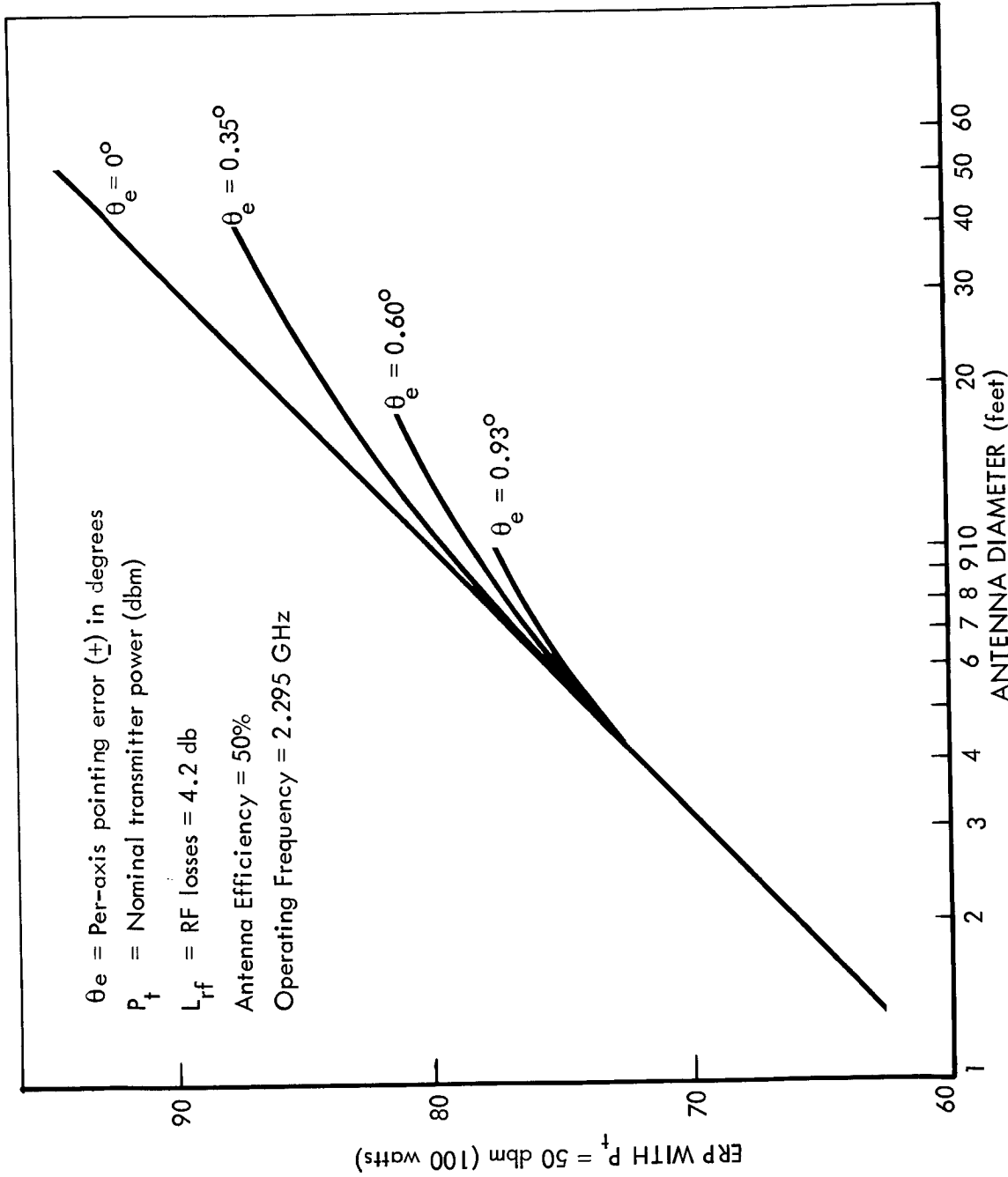

Figure C-5: SPACECRAFT ERP VERSUS ANTENNA DIAMETER FOR VARIOUS POINTING ERRORS

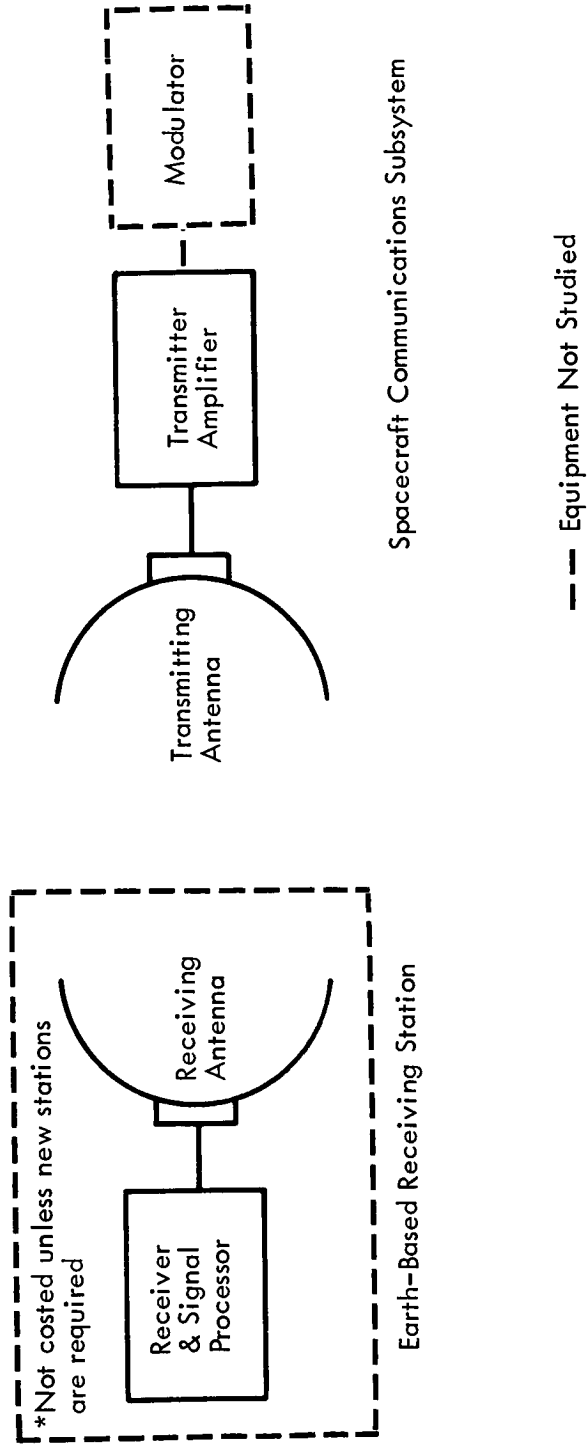

Figure C-6: TYPICAL S-BAND COMMUNICATIONS SUBSYSTEM ELEMENTS

Table C-3: SUBSYSTEM A

Antenna Diameter: 13.7 feet

Amplifier Power: 50 watts

Radio Frequency
Link Analysis:

Transmitter power (P_t)	+17.0 dbw (47 dbm)
Transmitter circuit RF losses	-4.2 db
Transmitting antenna gain (G_o)	+37.0 db
Transmitting antenna pointing loss (L_p)	-1.5 db
Space Loss (L_s) at 1 A.U.	-263.5 db
Polarization loss, receiving antenna	-0.1 db
Receiving antenna gain (210 feet DSIF)	+60.9 db
Receiving antenna pointing loss	-0.2 db
	<hr/>
Total Received Power	-154.6 dbw
Frequency	S-band
Effective radiated power (ERP)	77.3 dbm (47.3 dbw)
Received carrier-to-noise power density ratio (C/kT_s)	57.88 db

Table C-4: SUBSYSTEM A--WEIGHT AND POWER SUMMARY

Identification/ Nomenclature	Weight (lb)	Power (kw)	Area/ Volume	Lead Time		Cost (in millions)		Ref. (31) Remarks
				Technology	R&D	R&D**	First Article	
Power Amplifier	8	0.15		0	0			Elmac SOW TWT (EM 1249) incl. circ. switches n=0.33
High-Gain Ant.				0	0			13.7 ft, 37-db gain
Dish & Feed	82							Parabolic dish
Boom & Hinge	25							
Stowage Mechanism	4							
Deploy Mechanism	6							
Pointing Control	20	0.02						+0.1°
Support Struct.	21							
	<u>166</u>	<u>0.17</u>						
Spares & Repair Kits	40							500-day quantity

**including flight test

*enter area or volume if pertinent

Table C-5: SUBSYSTEM B

Antenna Diameter: 4 feet
 Amplifier Power: 70 watts
 Radio Frequency
 Link Analysis:

Transmitter power (P_t)	+18.5 dbw (48.5 dbm)
Transmitter circuit RF losses	-4.2 db
Transmitting antenna gain (G_o)	+27.0 db
Transmitting antenna pointing loss (L_p)	-0.5 db
Space loss (L_s) at 1 A.U.	-263.5 db
Polarization loss, receiving antenna	-0.1 db
Receiving antenna gain (210 feet DSIF)	+60.9 db
Receiving antenna pointing loss	-0.2 db
<hr/>	
Total Received Power	-162.1 dbw
Frequency	S-band
Effective radiated power (ERP)	70.8 dbm (40.8 dbw)
Received Carrier-to-noise power density ratio (C/kT_s)	51.38 db

Table C-6: SUBSYSTEM B--WEIGHT AND POWER SUMMARY

Identification/ Nomenclature	Weight (lb)	Power (kw)	Area/ Volume	Lead Time		Cost (in millions)		Remarks Reference 34
				Technology	R&D	R&D**	First Article	
Power Amplifier	7	0.140		0	0			Ampliftron & supply 70w RF out n = 0.5
Antenna	8							27 db, 4-ft. dia. dish
Boom	1(e)							
Pointing Control	1(3)	0.020						
	<u>17</u>	<u>0.160</u>						
Spares & Repair Kits	12							500-day quantity

(e) estimated

*enter area or volume if pertinent **including flight test

Table C-7: SUBSYSTEM C

Antenna Diameter: 43 feet

Amplifier Power: 50 watts

Radio Frequency

Link Analysis:

Transmitter power (P_t)	+17.0 dbw (47 dbm)
Transmitter circuit RF losses	-4.2 db
Transmitting antenna gain (G_o)	+47.0 db
Transmitting antenna pointing loss (L_p)	-3.0 db*
Space Loss (L_s at 1 A.U.)	-263.5 db
Polarization loss, receiving antenna	-0.1 db
Receiving antenna gain (210 feet DSIF)	+60.9 db
Receiving antenna pointing loss	-0.2 db
<hr/>	
Total Received Power	-146.1 dbw
Frequency	S-band
Effective radiated power (ERP)	86.8 dbm (56.8 dbw)
Received carrier-to-noise power density ratio (C/kT_s)	67.38 db

*This large antenna requires improved pointing control to keep
 $L_p \leq -3.0$ db.

Table C-8: SUBSYSTEM C--WEIGHT AND POWER SUMMARY

Identification/ Nomenclature	Weight (lb)	Power (kw)	Area/ Volume	Lead Time		Cost (in millions)		Remarks Reference 33
				Technology	R&D	R&D**	First Article	
Power Amplifier	8	0.15		0	0			Elmac SOW TWT (EM-1249) incl. circ. switches n=0.33
Antenna System	392	0.1			4			43-ft. parabolic dish
	400	0.3						
Spares & Repair Kit	70							500-day quantity

**including flight test

*enter area or volume if pertinent

Table C-9: SUBSYSTEM D

Antenna Diameter: 19 feet

Amplifier Power: 360 watts

Radio Frequency
Link Analysis:

Transmitter power (P_t)	+25.6 dbw (55.6 dbm)
Transmitter circuit RF losses	-4.2 db
Transmitting antenna gain (G_o)	+39.9 db
Transmitting antenna pointing loss (L_p)	-2.7 db
Space loss (L_s) at 1 A.U.	-263.5 db
Polarization loss, receiving antenna	-0.1 db
Receiving antenna gain (210 feet DSIF)	+60.9 db
Receiving antenna pointing loss	-0.2 db
	<hr/>
Total Received Power	-144.3 dbw
Frequency	S-band
Effective radiated power (ERF)	88.6 dbm (58.6 dbw)
Received carrier-to-noise power density ratio (C/kT_s)	69.18 db

Table C-10: SUBSYSTEM D--WEIGHT AND POWER SUMMARY

Identification/ Nomenclature	Weight (lb)	Power (kw)	Area/ Volume	Lead Time		Cost (in millions)		Remarks
				Technology	R&D	R&D**	First Article	
Power Amplifier	20(e)	1.03						ESFK (Reference 32) 360w Tx Power n = 35
High-Gain Antenna				0	0			39.9 db
Dish & Feed	151							19-ft. dish
Boom & Hinge	46							
Stowage Mechanism	7							
Deploy Mechanism	11							
Pointing Control	36	0.04						+0.1°
Support Structure	38							
	309	1.07						
Spares & Repair Kits	90							500-day quantity

(e) estimated

*enter area or volume if pertinent **including flight test

Table C-11: SUBSYSTEM E

Antenna Diameter: 19 feet

Amplifier Power: 140 watts

Radio Frequency

Link Analysis:

Transmitter power (P_t)	+21.5 dbw (51.5 dbm)
Transmitter circuit RF losses	-4.2 db
Transmitting antenna gain (G_o)	+39.9 db
Transmitting antenna pointing loss (L_p)	-2.7 db
Space loss (L_s) at 1 A.U.	-263.5 db
Polarization loss, receiving antenna	-0.1 db
Receiving antenna gain (210 feet DSIF)	+60.9 db
Receiving antenna pointing loss	-0.2 db
<hr/>	
Total Received Power	-148.4 dbw
Frequency	S-band
Effective radiated power (ERP)	84.5 dbm (54.5 dbw)
Received carrier-to-noise power density ratio (C/kT_s)	65.08 dbm

Table C-12: SUBSYSTEM E--WEIGHT AND POWER SUMMARY

Identification/ Nomenclature	Weight (lb)	Power (kw)	Area/ * Volume	Lead Time		Cost (in millions) First Article	Remarks
				Technology	R&D		
Power Amplifier	15(e)	0.420		0	1		ESPK (Elmac 3065A) I40w Trans. Power n = 0.33
High-Gain Antenna				0	0		39.9 db
Dish & Feed	151						19 ft. dish
Boom & Hinge	46						
Stowage Mechanism	7						
Deploy Mechanism	11						
Pointing Control	36	0.04					$\pm 0.1^\circ$
Support Structure	38						
	304	0.400					
Spares & Repair Kits	70						500-day quantity

(e) estimated

*enter area or volume if pertinent

**including flight test

Table C-13: SUBSYSTEM F

Antenna Diameter: 20.5 feet

Amplifier Power: 1350 watts

Radio Frequency

Link Analysis:

Transmitter power (P_t)	+31.3 dbw (61.3 dbm)
Transmitter circuit RF losses	-4.2 db
Transmitting antenna gain (G_o)	+40.5 db
Transmitting antenna pointing loss (L_p)	-3.0 db
Space loss (L_s) at 1 A.U.	-263.5 db
Polarization loss, receiving antenna	-0.1 db
Receiving antenna gain (210 feet DSIF)	+60.9 db
Receiving antenna pointing loss	-0.2 db
	<hr/>
Total Received Power	-138.3 dbw
Frequency	S-band
Effective radiated power (ERP)	94.6 dbm (64.6 dbw)
Received carrier-to-noise power density ratio (C/kT_s)	75.18 db

Table C-14: SUBSYSTEM F--WEIGHT AND POWER SUMMARY

Identification/ Nomenclature	Weight (lb)	Power (kw)	Area/ * Volume	Lead Time		Cost (in millions)		Remarks
				Technology	R&D	R&D**	First Article	
Power Amplifier	100	2.97						P _T = 1350w (ESFK) n = 0.454 (Reference 32)
High-Gain Antenna								40.5 db
Dish & Feed	160							20.5-ft dish
Boom & Hinge	46							
Stowage Mechanism	7							
Deploy Mechanism	11							
Pointing Control	36	0.04						+0.1°
Support Structure	38							
	398	3.01						
Spares & Repair Kits								500-day quantity

**including flight test

*enter area or volume if pertinent

C-6.0 ANTENNA AND TRANSMITTER POWER AMPLIFIER COSTS

Research and development costs (R&D) for antennae and transmitter power amplifiers are shown parametrically in Figures C-7 and C-8. Unit costs for the same items are shown in Figures C-9 and C-10. The parametric costs shown were developed according to the following assumptions and ground rules:

- Costing graphs are for antennae and power amplifiers only and do not constitute total subsystems cost;
- Costs shown do not include any program management, sustaining engineering, integration or systems qualification, special test equipment or aerospace ground equipment;
- Costs for antennae and power amplifiers assume other equipment is constant for all types and missions;
- Antenna costs are based on weight estimates taken from finance parametric costing curves;
- Amplifier costs are based on weight and plotted by watt, based on finance parametric cost curves.

A single point estimate was obtained for the laser subsystem described in this appendix. Cost information on deep space laser communications equipment is difficult to obtain, and a single point estimate was all that could be obtained in a timely manner for this study. The described laser subsystem is estimated to cost \$210 million for R&D, and to cost \$6.4 million for the first article.

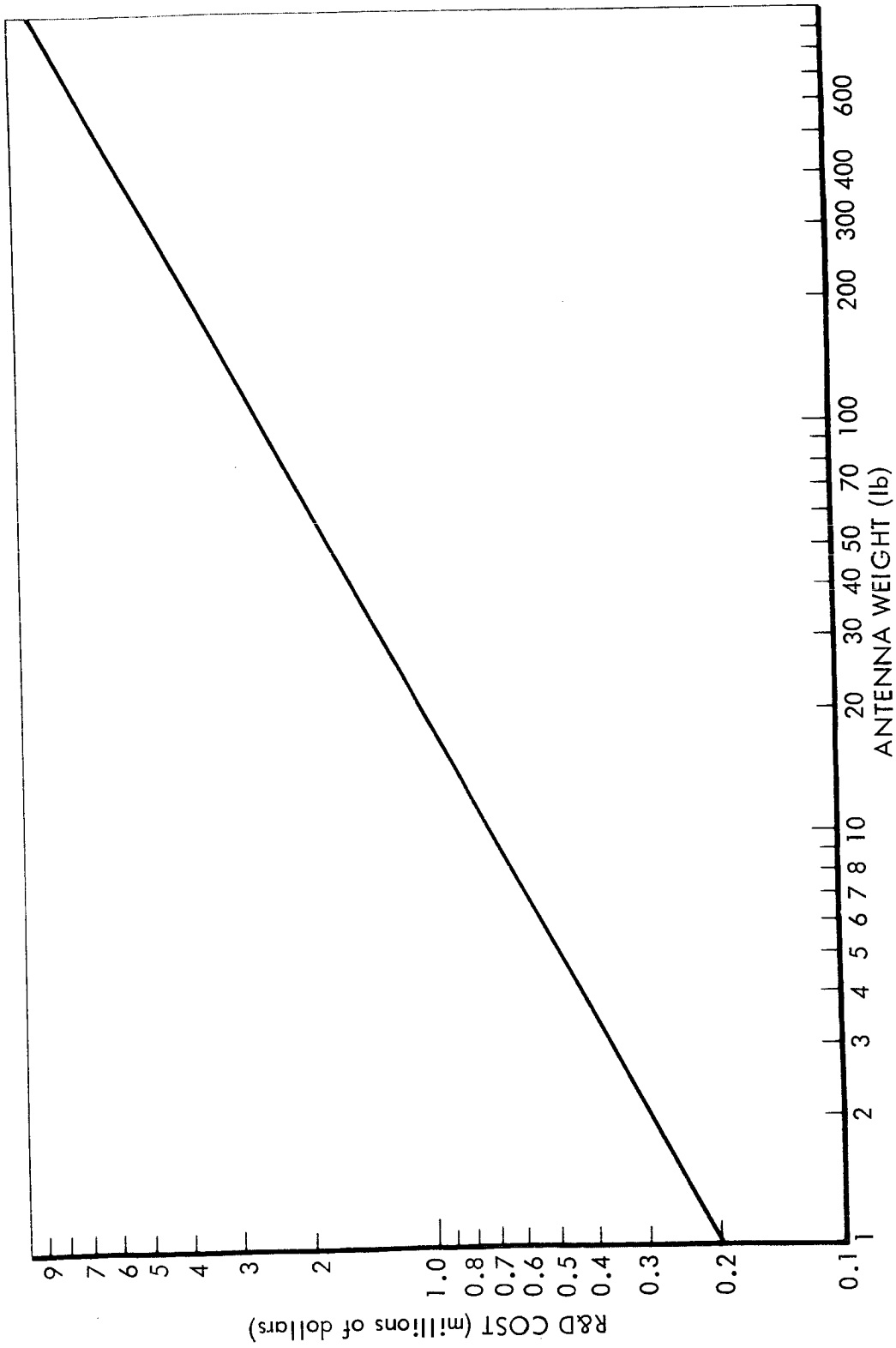

Figure C-7: R&D COST VERSUS ANTENNA WEIGHT

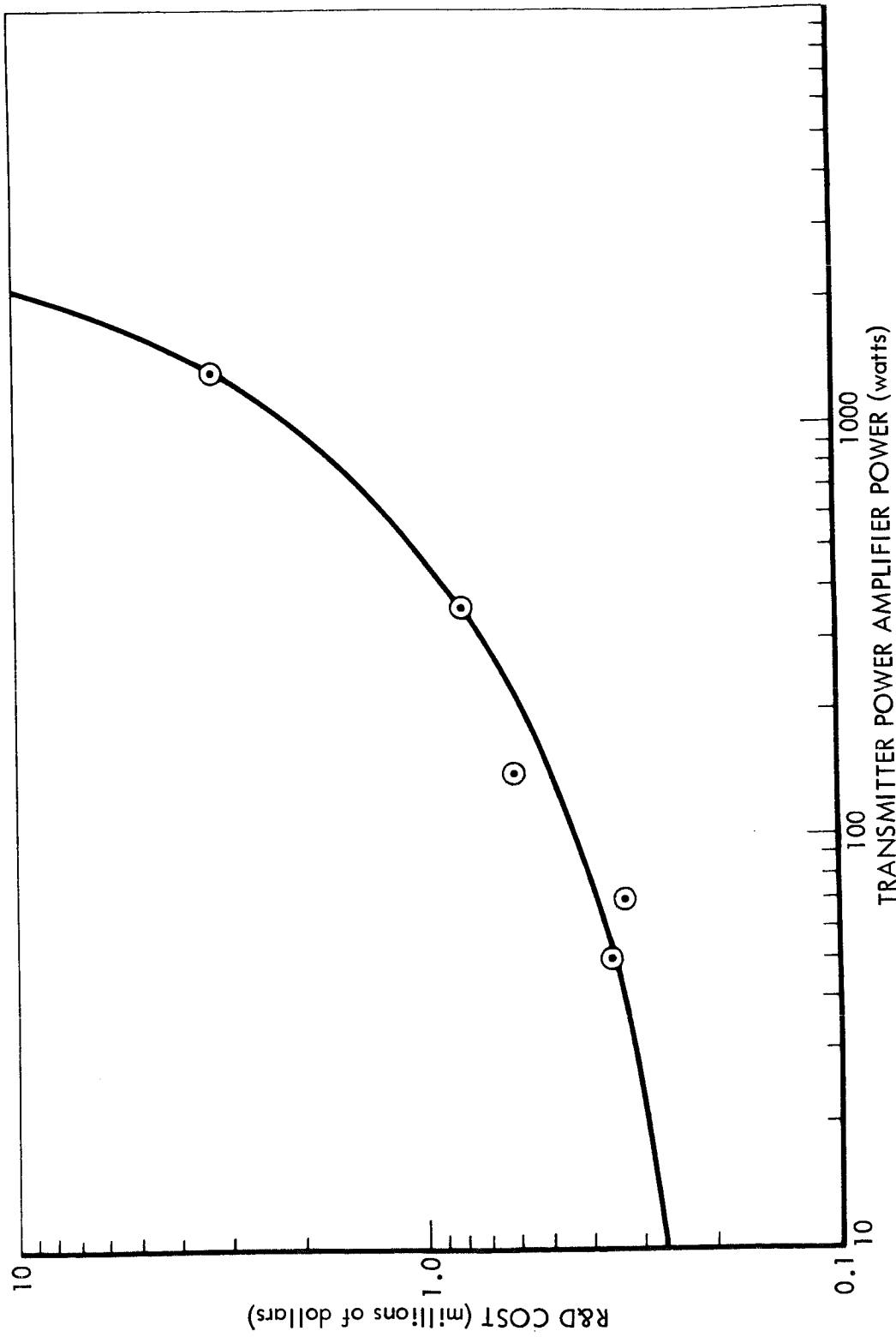

Figure C-8: R&D COST VERSUS TRANSMITTER POWER AMPLIFIER POWER

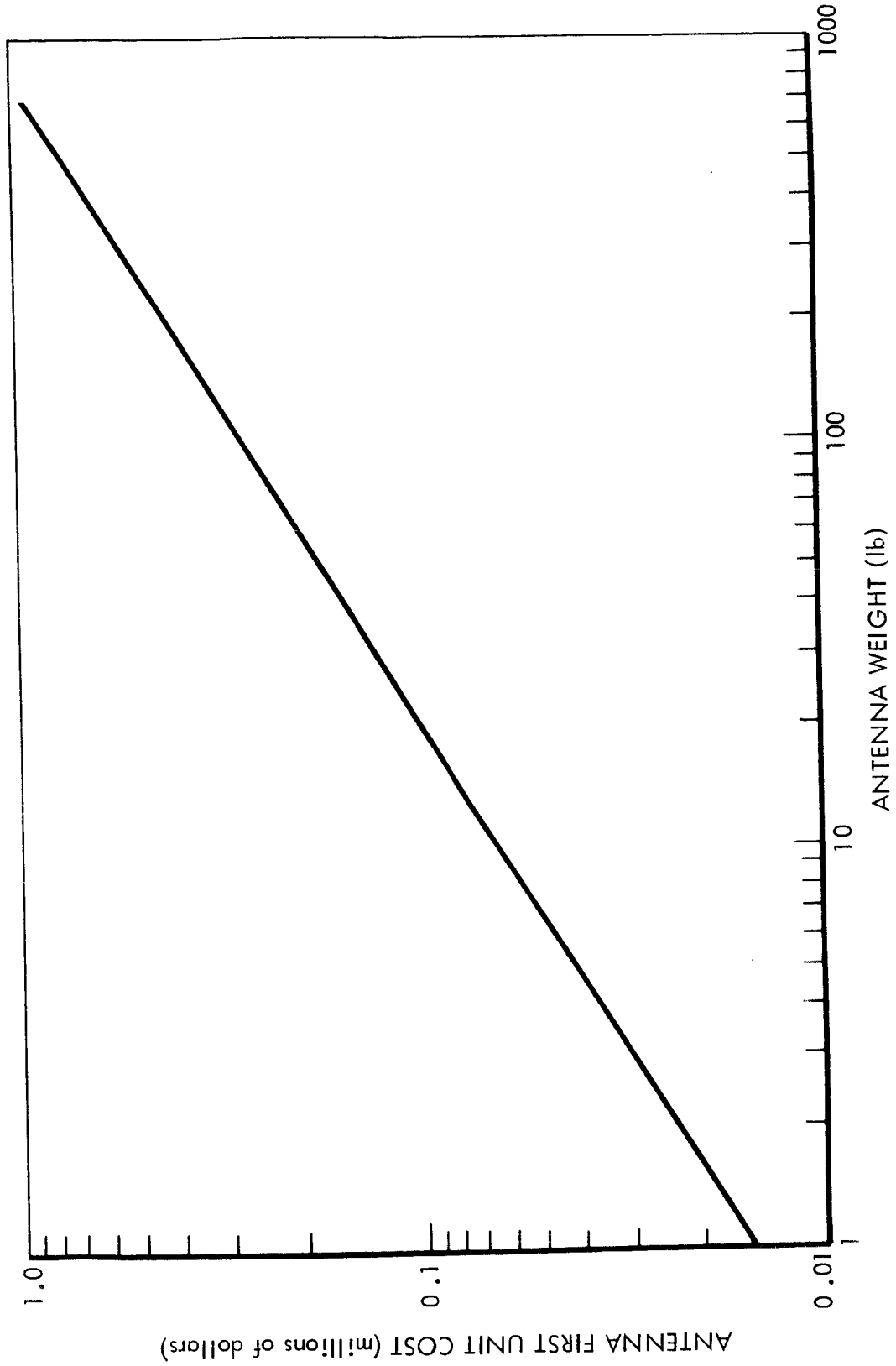

Figure C-9: ANTENNA FIRST UNIT COST VERSUS ANTENNA WEIGHT

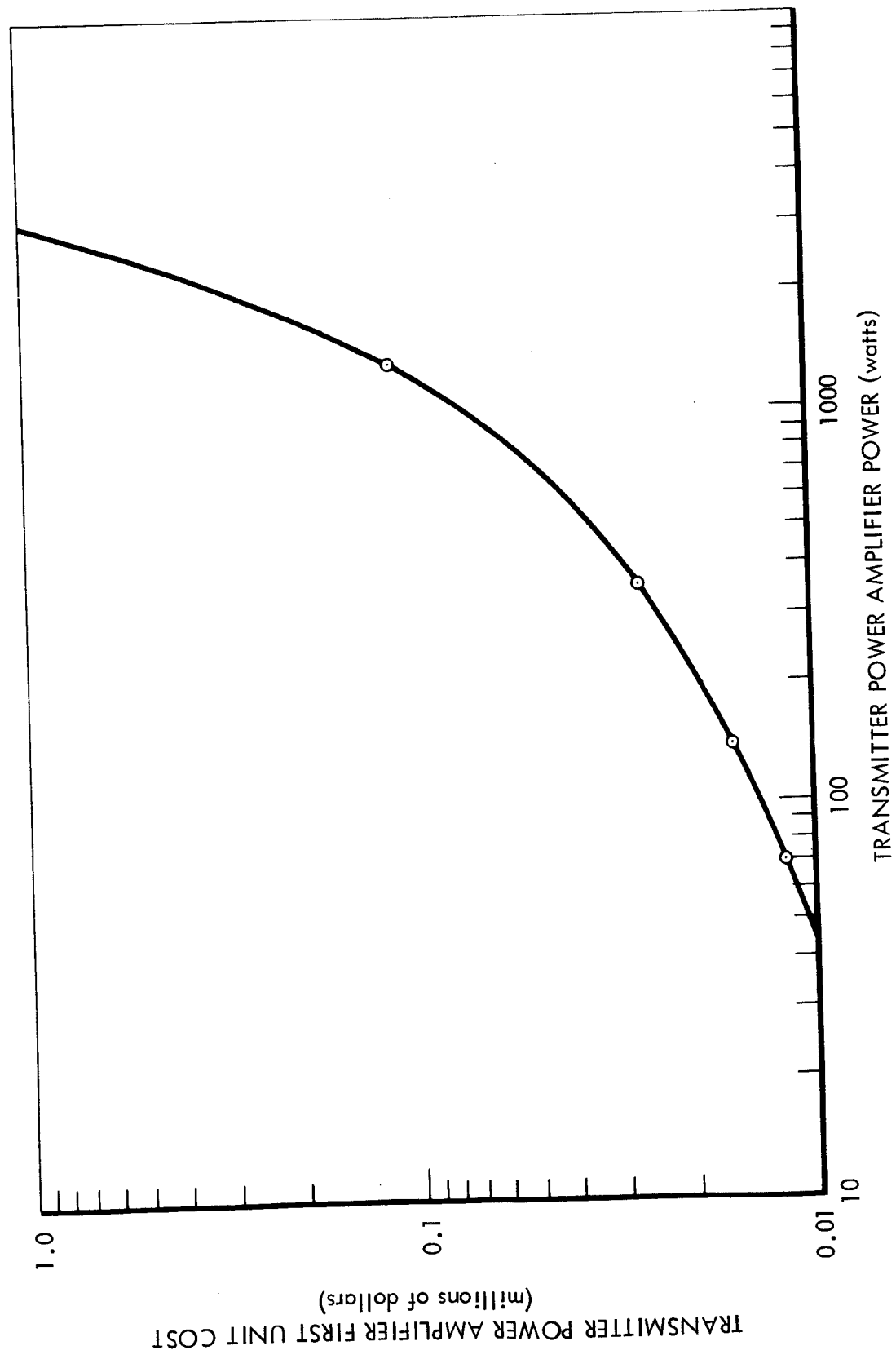

Figure C-10: FIRST UNIT COST VERSUS TRANSMITTER POWER AMPLIFIER POWER

D2-113544-6

APPENDIX D

STUDY OF WATER MANAGEMENT SUBSYSTEMS

CONTENTS

	<u>Page</u>
D-1.0 INVESTIGATION OF WATER MANAGEMENT SUBSYSTEMS	217
D-1.1 Summary	217
D-2.0 GROUND RULES AND BASELINE REQUIREMENTS	219
D-2.1 Water Balance Data	219
D-2.2 Waste Water Reclamation	220
D-2.3 Contaminants	220
D-2.4 Reliability	221
D-3.0 CONCEPT VARIATIONS STUDIED	222
D-4.0 METHOD OF COMPARISON	224
D-5.0 DESCRIPTION OF CANDIDATE WATER MANAGEMENT SUBSYSTEMS	226
D-5.1 Multifiltration	226
D-5.1.1 Weight and Power	226
D-5.1.2 Multifiltration Expendables	228
D-5.1.3 Development	228
D-5.2 Air Evaporation	230
D-5.2.1 Weight and Power	230
D-5.2.2 Air Evaporation Expendables	232
D-5.2.3 Development	233
D-5.3 Vacuum Compression Distillation	233
D-5.3.1 Weight and Power	234
D-5.3.2 Vacuum Compression Distillation Expendables	236
D-5.3.3 Development	237
D-5.4 Reverse Osmosis	237
D-5.4.1 Weight and Power	238
D-5.4.2 Reverse Osmosis Expendables	240
D-5.4.3 Development	241
D-5.5 Electrodialysis	242
D-5.5.1 Weight and Power	245
D-5.5.2 Expendables	246
D-5.5.3 Development	247
D-6.0 ESTIMATED COSTS	249
D-6.1 Costing Ground Rules and Assumptions	249

D-1.0 INVESTIGATION OF WATER MANAGEMENT SUBSYSTEMS

This appendix describes typical water management subsystems for a National Space Station, Mars, and Venus missions. Included in this section are water balance data; concept descriptions and block diagrams of candidate concepts; weight, power, and expendable estimates; and assessment of current technology of each concept.

D 1.1 SUMMARY

The water management subsystem consists of the equipment for collection, recovery, and storage of water. This equipment must provide the water for drinking, food preparation, and crew hygiene, as well as water losses resulting from cabin leakage, portable life support systems, and other subsystem losses. Water makeup for losses not associated with water reclamation is not included in this study, since losses are identical for all reclamation concepts and are dependent on factors not associated with water management.

Selection of best water reclamation techniques depends on many factors including reliability, weight, power, volume, and cost. Table D-1 shows data on the water reclamation techniques considered in this study.

For condensate water reclamation, multifiltration is the simplest and lightest weight for short missions. For long missions, other processes must be evaluated, particularly if the efficiencies are approximately equal to the multifiltration efficiency.

For wash water reclamation, air evaporation and vacuum compression distillation are currently the least-weight techniques. Electrodialysis and reverse osmosis, with approximately 95% efficiency, require a second water reclamation step to recover the water in the 5% brine. With this second step, the water recovery efficiency becomes 99 to 100%. The primary advantage of the electrodialysis and reverse osmosis processes is high water flow rate at low power penalty. The major disadvantages are involved with the development and life of the membranes.

For the long missions, air evaporation and vacuum compression distillation are the most competitive. Of these two techniques, air evaporation water reclamation is simpler, has higher water-recovery efficiency, has higher expendables weight and volume, and is dependent on availability of waste heat. Vacuum compression distillation has complex hardware, lower expendables, and is less dependent on other spacecraft systems. Both concepts are now being developed, and it is difficult to select the optimum one.

For urine reclamation, electrodialysis, although not competitive from an expendables standpoint, must be considered since development of the electrolysis pretreatment to break down the urea may reduce expendables to a point where it is competitive with the air evaporation or vacuum compression techniques.

Table D-1: LIFE SUPPORT (WATER MANAGEMENT) CONCEPTS: WEIGHTS, WEIGHT RATES AND POWERS

Waste Water	Six-Man Production Rate	Concept	Fixed Weight pounds (kg)	Power Required (watts)	Expendables per lb of Waste Water (pounds)	Water per lb of Waste Water (pounds)	Total Rate: lbs/lb of Waste Water (pounds)	Loop Efficiency	Total Six-Man Rate (pounds/day)
Condensate	18.54 lb/day (8.42)	Multifiltration	32.7 (14.85)	18.3	0.0041	0.0050	0.0091	99.5	0.1687
		Air evaporation	84.65 (38.43)	37.3/280.3*	0.0006	0.0050	0.0056	99.5	0.1038
		Vacuum compression	88.46 (40.16)	17.8/54.1	0.0004	0.0140	0.0144	98.6	0.2670
		Reverse osmosis** ***	86.23 (39.15)	40.3	0.0004	0.0050	0.0054	99.5	0.1001
		Electrodialysis**	28.8 (13.08)	30.3	0.0024	0.0006	0.0030	99.94	0.0556
Wash	32.7 lb/day (14.85)	Multifiltration	32.7 (14.85)	18.3	0.0228	0.0100	0.0328	99.0	1.0726
		Air evaporation	84.65 (38.43)	37.3/280.3	0.0029	0.0100	0.0129	99.0	0.4218
		Vacuum compression	88.46 (40.16)	17.8/54.1	0.0019	0.0140	0.0159	98.6	0.5199
		Reverse osmosis** ***	86.23 (39.15)	40.3	0.00216	0.0050	0.00716	99.5	0.2354
		Electrodialysis** ***	28.8 (13.08)	30.3	0.0028	0.0006	0.0034	99.94	0.1112
Urine	20.7 lb/day (9.40)	Air evaporation	84.65 (38.43)	37.3/280.3	0.0280	0.0100	0.0380	99.0	0.7866
		Vacuum compression	88.46 (40.16)	17.8/54.1	0.0205	0.0140	0.0345	98.6	0.7142
		Electrodialysis** ***	28.8 (13.08)	30.3	0.0861	0.0320	0.1181	96.8	2.4447
								95.0	2.8713

*Thermally Integrated/Not Thermally Integrated.

**With Brine Reclamation.

***Without Brine Reclamation.

D-2.0 GROUND RULES AND BASELINE REQUIREMENTS

D-2.1 WATER BALANCE DATA

Human requirements for water vary widely with conditions of exposure, activity, and diet. The rate of water loss from the body is also widely variable. Table D-2 shows water balance data for this study, along with data from other studies.

Table D-2: MAN'S WATER BALANCE DATA

	This Study	Bioastro Handbook Reference 13	NASA LRC Reference 14	NASA MSC Reference 15	GARD Reference 16	Marquardt Reference 17	Douglas Reference 18	ILSS Reference 19
Intake Water								
Food and drink	6.13	4.64	4.84	6.07	6.5	6.5	6.17	7.72
Metabolic	<u>.66</u>	<u>.66</u>	<u>.66</u>	<u>.34</u>	<u>.55</u>	<u>.66</u>	<u>.79</u>	<u>.72</u>
Total	6.79	5.30	5.50	6.41	7.05	6.79	6.96	8.44
Output								
Urine water	3.45	3.08	3.08	3.08	2.67	3.45	3.92	3.30
Feces water	.25	.22	.22	.22	.55	.25	.26	.25
Perspiration and respiration	<u>3.09</u>	<u>2.00</u>	<u>2.20</u>	<u>3.11</u>	<u>3.83</u>	<u>3.09</u>	<u>2.78</u>	<u>4.89</u>
Total	6.79	5.30	5.50	6.41	7.05	6.79	6.96	8.44
Wash water	5.45		4.0	26.4		26.4	3.0	3.30

D-2.2 WASTE WATER RECLAMATION

Mixing of the various waste waters generally is not desirable since it will raise the contaminant level of the least-contaminated water and increase the complexity of water reclamation. Condensate is the least contaminated and is easy to reclaim by filtration. By comparison, fecal water is the most contaminated, requires a more complex processing method, and results in the smallest gain.

Since the four types of waste water contain dissimilar contamination, separate units are suggested for each type. Wherever possible, it is desirable to use similar purification units for the different wastes to increase the redundancy and reliability of the overall water management subsystem. In general, condensate should be treated separately and be one of the primary sources of potable water. Water recovered from urine should first be used for wash water; then, the purified wash water, along with recovered condensate water, is used for food and drink. By this technique the most contaminated water is processed more than one time before being used for food and drink.

D-2.3 CONTAMINANTS

Contaminant level of the water to be purified is one of the determining factors in the choice of reclamation techniques. The contamination levels of waste fluids are approximately as shown in Table D-3.

Table D-3: WASTE WATER SOLIDS CONTENT

Waste Water	Average Solids Content
Condensate	70 parts per million
Wash Water	0.25%
Urine	
Urea	2.45%
Inorganic salts	1.37%
Various organics	1.08%
	4.90%
Fecal Wastes	25.0%

The contaminants in condensate, wash water, and urine include both suspended solids and dissolved solutes. The dissolved solutes include both ionic and nonionic compounds, of both volatile and non-volatile classification. Because of the dissimilarity in contaminants, most recovery systems require a minimum of two processing steps to remove the contaminants. These processes include filtration, absorption, ion-exchange, dialysis, and phase-change. The water reclamation techniques, including the above processes, that are covered by this study are multifiltration, closed cycle air evaporation, vacuum compression distillation, reverse osmosis, and electrodialysis.

D-2.4 RELIABILITY

To make equal performance comparisons possible, each recovery process was improved to a reliability of .998 through the addition of spares. This improvement was made by obtaining estimated failure rates for the various processing concepts and running that information through a reliability optimization program to determine the weight of spares to be added. Where a single processing concept was to be used for reclamation of two or more of the waste waters, full advantage of equipment commonality was taken to minimize the number of spares. The weights of spares to be added for a two-year mission are shown in Table D-4. For missions of different lengths, the two-year spares weights were scaled according to a relationship determined in Reference 1 shown in Figure 5.4-1 in the basic document.

Table D-4: WATER RECOVERY PROCESS 2-YEAR SPARES WEIGHTS

Concept	1 Unit Pounds	2 Units Pounds	3 Units Pounds
Multifiltration	38.0	44.2	---
Air Evaporation	64.7	80.35	95.85
Vacuum Compression Distillation	100.33	145.48	157.86
Reverse Osmosis	147.08	167.08	---
Electrodialysis	22.15	31.40	36.3

D-3.0 CONCEPT VARIATIONS STUDIED

Five different waste water recovery concepts are described. Assuming fecal water is not to be recovered, three types of waste water could be recovered by any possible combination of the five recovery concepts. To reduce the number of combinations, multifiltration and reverse osmosis may be eliminated from urine recovery because they are impractical in that use. Table D-5 shows a matrix of the remaining combinations. Those combinations enclosed are candidates for selection as optimal subsystem concepts. The combinations not enclosed have all been eliminated for various reasons. In particular, the following are eliminated:

- Combinations of three reclamation methods where two or more have similar characteristics (reverse osmosis and electro dialysis, for example).
- Combinations where complex reclamation methods are used for condensate, and less complex or higher-rate methods are used for the more contaminated waste waters.

Table D-5: COMBINATIONS OF WATER RECOVERY CONCEPTS

<u>Waste Water</u>			<u>Waste Water</u>			<u>Waste Water</u>			<u>Waste Water</u>			<u>Waste Water</u>		
Condensate	Wash	Urine	Condensate	Wash	Urine	Condensate	Wash	Urine	Condensate	Wash	Urine	Condensate	Wash	Urine
MF	MF	AE	AE	MF	AE	VC	MF	AE	RO	MF	AE	ED	MF	AE
		VC			VC			VC			VC			VC
		ED			ED			ED			ED			ED
MF	AE	AE	AE	AE	AE	VC	AE	AE	RO	AE	AE	ED	AE	AE
		VC			VC			VC			VC			VC
		ED			ED			ED			ED			ED
MF	VC	AE	AE	VC	AE	VC	VC	AE	RO	VC	AE	ED	VC	AE
		VC			VC			VC			VC			VC
		ED			ED			ED			ED			ED
MF	RO	AE	AE	RO	AE	VC	RO	AE	RO	RO	AE	ED	RO	AE
		VC			VC			VC			VC			VC
		ED			ED			ED			ED			ED
MF	ED	AE	AE	ED	AE	VC	ED	AE	RO	ED	AE	ED	ED	AE
		VC			VC			VC			VC			VC
		ED			ED			ED			ED			ED

MF = Multifiltration
 AE = Air Evaporation
 VC = Vacuum Compression
 RO = Reverse Osmosis
 ED = Electrodialysis

Candidate Combinations

D-4.0 METHOD OF COMPARISON

To make a comparison of subsystem concepts capable of equal performance, it is necessary to consider the efficiencies of the various processes, and the interaction of different processes when combined as one subsystem. The different efficiencies are considered by making up any water lost in the reclamation process. Therefore, if 1.0 pound of urine water* is to be processed, and the process efficiency is 95%, then 0.05 pound of water must be made up. Whether this makeup water will actually be carried aboard a space vehicle depends on a more detailed analysis of the space vehicle water balance.

Some recovery concepts can benefit significantly if the residual brine solution can be reprocessed. It has been assumed that this is possible whenever one of the waste waters is recovered by vacuum compression.

To make a comparison of the various combinations for the assumed flight program, the major parameters are combined in the following equations, where they are reduced to elements of cost.

$$C_t = C_{nr} + C_{rec} + C_{acc} + C_{spr}$$

where

C_t is total cost

and

C_{nr} = non-recurring cost

C_{rec} = recurring cost

C_{acc} = acceleration cost

C_{spr} = spares cost

$$C_{nr} = C_{te} + C_d$$

where

C_{te} is cost of technology development

and

C_d is R&D cost

*One pound of urine does not contain one pound of H₂O; a good part of the weight is solids, etc. Even if the process were 100% efficient, one pound of water could not be reclaimed from one pound of urine. Therefore, the phrase "urine water" implies one pound of H₂O contained in some larger amount of urine.

$$C_{rec} = (M_1 + M_2)(C_r + P \times C_p)$$

where

M_1 is the number of NSS missions

and

M_2 = number of interplanetary missions

C_r = unit cost

P = unit power requirement

C_p = cost of power

$$C_{acc} = M_2 \times C_4 (W_f + W_r \times T_{lt} + P \times P_p + W_{s1}) + C_1 (M_1 (W_f + P \times P_p) + W_{s2} + W_{s3} + W_{s4} + W_r \times T_{ml})$$

where

C_4 is interplanetary round-trip acceleration cost in dollars/pound

and

C_1 = acceleration cost to Earth orbit

W_f = fixed (unit) weight

W_r = weight rate of expendables and make-up in pounds/day

T_{lt} = interplanetary trip time in days

P_p = power penalty in pounds/watt

W_{s1} = weight of spares for interplanetary missions

W_{s2} = weight of spares for 2 years

W_{s3} = weight of spares for 3 years

W_{s4} = weight of spares for 5-year missions

T_{ml} = total length of NSS missions in days

$$C_{spr} = C_{sw} (W_{s1} + W_{s2} + W_{s3} + W_{s4})$$

where

C_{sw} = cost of spares in dollars/pound

D-5.0 DESCRIPTIONS OF CANDIDATE WATER MANAGEMENT SUBSYSTEMS

D-5.1 MULTIFILTRATION

Multifiltration is one of the simplest and most reliable water reclamation concepts. It is capable of removing mechanically suspended solids from a solvent, and is limited only by pore size and quantity of filter medium. A multifiltration system cannot remove dissolved contaminants. The system basically consists of a series of filters, a particulate filter, an activated charcoal bed, and a bacterial filter. The addition of ion exchange resins makes a system that is capable of processing wash water (see Figure D-1).

D-5.1.1 WEIGHT AND POWER

An estimated fixed weight and power breakdown for a six-man multifiltration system for either condensate or wash water processing is shown in Table D-6.

Table D-6: MULTIFILTRATION PARTS LIST

<u>Component</u>	<u>Weight (pounds)</u>	<u>Power (watts)</u>
Pump	2.0	15
Pretreatment Accumulator	6.0	
Chemical Dispenser	0.8	
Charcoal Canisters (3)	3.0	
Ion Exchange Canisters	1.0	
Accumulator Tank	6.0	
Sterilizer	6.0	
Bacterial Filters	0.5	
Quick Disconnect (8)	2.4	
Conductivity Sensor	0.4	2.3
Manual Valves (4)	1.6	
Check Valves (1)	0.2	
Motor Valves (2)	1.0	5.0
Pressure Relief & Pressure Valves (3)	0.6	
Controls	1.0	1.0
Total	32.7	18.3 W _e (maximum continuous)

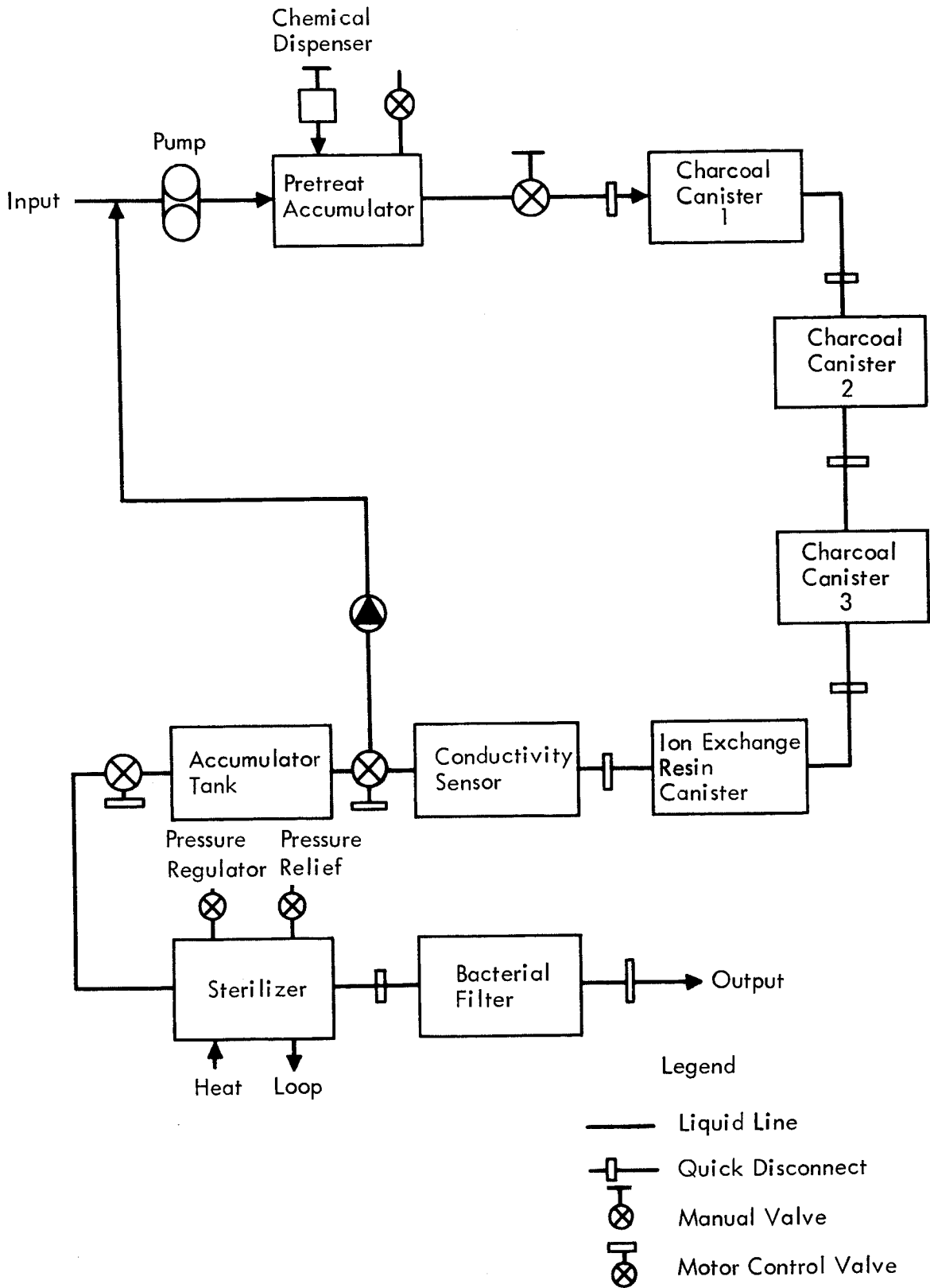

Figure D-1: MULTIFILTRATION WATER RECLAMATION

D-5.1.2 MULTIFILTRATION EXPENDABLES

The expendables are primarily activated charcoal and ion resins. The usage rate is as follows:

	<u>NASA-LRC Reference 14</u>	<u>Wallman Reference 20</u>
Condensate filtration, lb/lb H ₂ O	0.0041 (Includes hydration of filters)	0.0296 (No mention of hydration of filters)
Wash water filters	0.0175 to 0.0225	0.0228

For this study the following expendable rates will be used:

Condensate

Expendable weight	0.0041 lb/lb H ₂ O
Volume at 30 pounds filter/ft ³	0.236 in ³ /lb H ₂ O

Wash Water

Expendable weight	0.0228 lb/lb H ₂ O
Volume at 30 pounds filter/ft ³	1.31 in ³ /lb H ₂ O

Table D-7 summarizes makeup water and expendables rates for the multifiltration processing concept.

D-5.1.3 DEVELOPMENT

Multifiltration of condensate is well developed and has been used in submarines and space simulators, References 23 and 24.

A multifilter wash water recovery unit was built by General Dynamics/Electric Boat under NASA Contract, Reference 20.

The development time is estimated at 12 months.

Table D-7: MULTIFILTRATION MAKEUP AND EXPENDABLES RATES

	Condensate (lbs/lb Condensate)	Wash (lbs/lb Wash)	Urine (lbs/lb Urine)
<u>Expendables</u>			
Filters (including trapped water)	0.0041	0.0228	---
Total expendable rate: as shown			
<u>Efficiency (%)</u>	99.5	99.0	---
<u>Makeup Water (to balance 1.0 pound in/1.0 pound out)</u>	0.0050	0.0100	---
<u>Total Rate</u> (lb/lb of waste water)	0.0091	0.0328	---

D-5.2 AIR EVAPORATION

Air is used in this concept as the circulation medium; it carries water vapor from the evaporator to the condenser. Waste water is fed to a holding tank, where pretreatment chemicals are introduced. In the pretreatment, the urine is sterilized and the urea and other organics are rendered less susceptible to temperature destruction. Treated waste water is fed to a series of wicks within the evaporator. The pressure and temperature of the evaporator are such that the water contained in the wicks is evaporated. The air carries the water vapor to the condenser where the air stream is cooled to condense and recover the product water. Figure D-2 shows a schematic of a typical closed air evaporation system.

Operation of this system requires that heat be added upstream of the evaporator. The penalty for supplying this heat electrically is generally prohibitive; therefore, this system becomes attractive only when waste heat is available. Sufficient heat is normally available from the electronic equipment in the spacecraft. The overall weight penalty for this system is the sum of the basic weight of the system, the power penalty, the weight of pretreatment chemicals, disposable wicks, and the weight of charcoal used.

System efficiency is nearly 100%, since the wicks are dried prior to replacement, so that the only loss of water is the small amount left in the wicks. The advantages of this system are its recovery efficiency, its simplicity and its low weight. The disadvantages are the expendables which must be supplied, and the task of replacing the wick materials.

D-5.2.1 WEIGHT AND POWER

An estimated fixed weight and power breakdown for the six-man air evaporation system shown in Figure D-2 is shown in Table D-8. The component data were obtained from Reference 25.

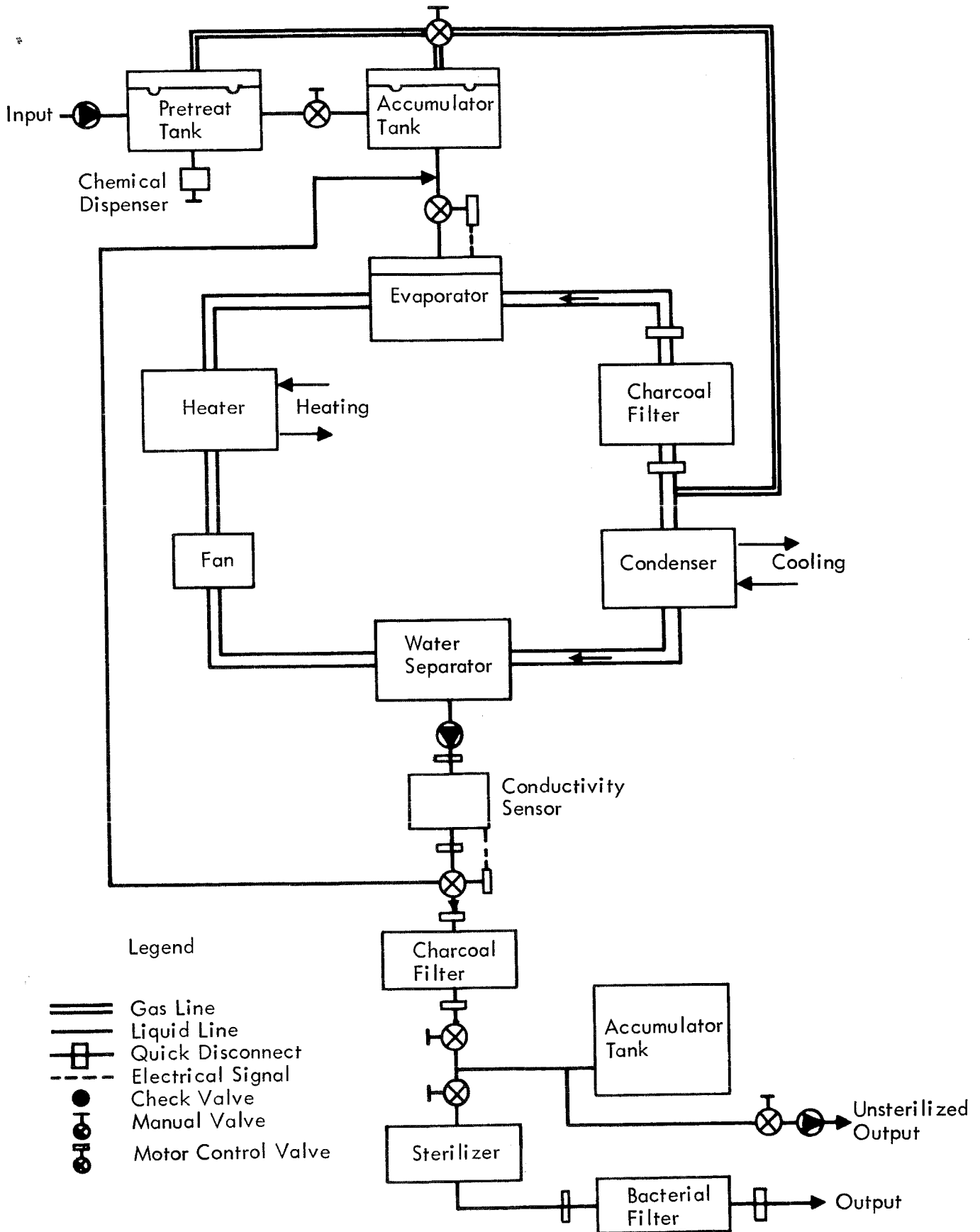

Figure D-2: AIR EVAPORATION WATER RECLAMATION

Table D-8: AIR EVAPORATION PARTS LIST

<u>Component</u>	<u>Weight (pounds)</u>	<u>Power (watts)</u>
Evaporator	4.0	
Charcoal Air Filter	1.0	
Heat Exchanger Heater	2.5	(243)
Heat Exchanger Condenser	3.0	
Water Separator	6.2	9.33
Pressure Switch	1.1	
Fan	2.5	25.67
Conductivity Sensor	0.4	2.3
Charcoal Filter	1.0	
Accumulator Tank (2)	7.1	
Sterilizer	6.0	
Bacterial Filter	0.5	
Pretreatment Tank	5.0	
Quick Disconnect (8)	9.6	
Check Valve (3)	0.6	
Manual Valve (6)	2.4	
Motor Valve (2)	3.0	5.0
Chemical Dispenser	0.4	
Relief Valve	0.25	
Ducts and Insulation	20.0	
Controls	<u>1.00</u>	
	84.65	<u>37.3 W_e</u> (maximum continuous) (243 W _t)

D-5.2.2 AIR EVAPORATION EXPENDABLES

Expendables for water recovery by air evaporation are shown in Table D-9.

Table D-9: AIR EVAPORATION MAKEUP AND EXPENDABLES RATES

	Condensate (lbs/lb Cond)	Wash (lbs/lb Wash)	Urine (lbs/lb Urine)
Expendables			
Pretreatment chemicals	--	--	
H ₂ SO ₄			0.00226
CrO ₂			0.00056
			0.00018
Wicks	0.0003	0.0020	0.02000
Charcoal and entrapped water	<u>0.0003</u>	<u>0.0009</u>	<u>0.0050</u>
Total Expendable Rate	0.0006	0.0029	0.0280
Efficiency	99.5	99.0	99.0
Makeup Water (to balance 1.0 pound in/1.0 pound out)	0.0050	0.010	0.010
Total Rate (lb/lb of waste water)	0.0056	0.0129	0.0380

D-5.2.3 DEVELOPMENT

The air evaporation process has had considerable development by several companies. Hamilton Standard has built a four-man flight prototype unit for test in the Integrated Life Support Subsystem test at NASA-LRC under Contract NAS1-2934. Testing of the ILSS began in 1966 and is continuing to date. Douglas Missile & Space Systems Division, Reference 21, is currently conducting manned chamber tests using various water recovery techniques, including air evaporation.

It is estimated that development time on an air evaporation unit is approximately 15 to 18 months.

D-5.3 VACUUM COMPRESSION DISTILLATION

One phase changing technique for reclaiming waste water is vacuum compression distillation. In this concept the water is evaporated in a vacuum and a vapor compressor is used to force the water vapor to condense at a higher temperature than when it evaporated. The heat of vaporization is conserved by designing the evaporator and condenser with a common heat-transfer wall. The energy required to operate this

system is that required to overcome friction and to elevate the temperature of the saturated vapor in the condenser by compression to a value sufficient for the required heat flow.

The vacuum compression distillation system consists of a rotating can-within-a-can type structure. The rotating can provides the centrifugal force necessary to insure operation of the unit in zero gravity and to cause the fluids to spread uniformly along the heat transfer wall.

The vacuum compression distillation concept, as shown schematically in Figure D-3, is part of an integrated water management subsystem, Reference 17. Vapor compression distillation is a batch process. Each batch containing 75 milliliters of preheated waste water is vaporized and condensed during a 10-minute cycle. The evaporator operates at 120°F and a pressure of approximately 1.7 psia. The condensation of steam is at approximately 130°F and 2.2 psia. The liquid residue containing the dissolved solids is removed from the surface of the evaporator after each batch by a motor-driven mechanical wiper that transfers the residue to a solids collector in the outer extreme of the rotating drum assembly. The residue is maintained in a fine layer by centrifugal force and is heated electrically to 120°F to remove additional water.

The solids are removed manually after 90 man-days of operation and stored.

The unit is purged of noncondensable gases to the vacuum of space. Purging is automatic and initiated by sensing a preset increase in condenser pressure. The waste water feed is also automatic and admits water to the evaporator when the evaporator pressure drops indicating that the water for evaporation is low.

D-5.3.1 WEIGHT AND POWER

A detailed parts list for a six-man urine water reclamation unit is shown in Table D-10.

For comparison with other water reclamation techniques, care must be exercised to compare systems on an equal basis. For comparison purposes in this study, the weight of the vacuum compression distillation unit is for a flow rate of 20.7 pounds/day. This rate is for urine recovery, where vacuum compression is most competitive. If vacuum compression is indicated as optimum for wash water recovery, the unit must be scaled up and the trade reconsidered.

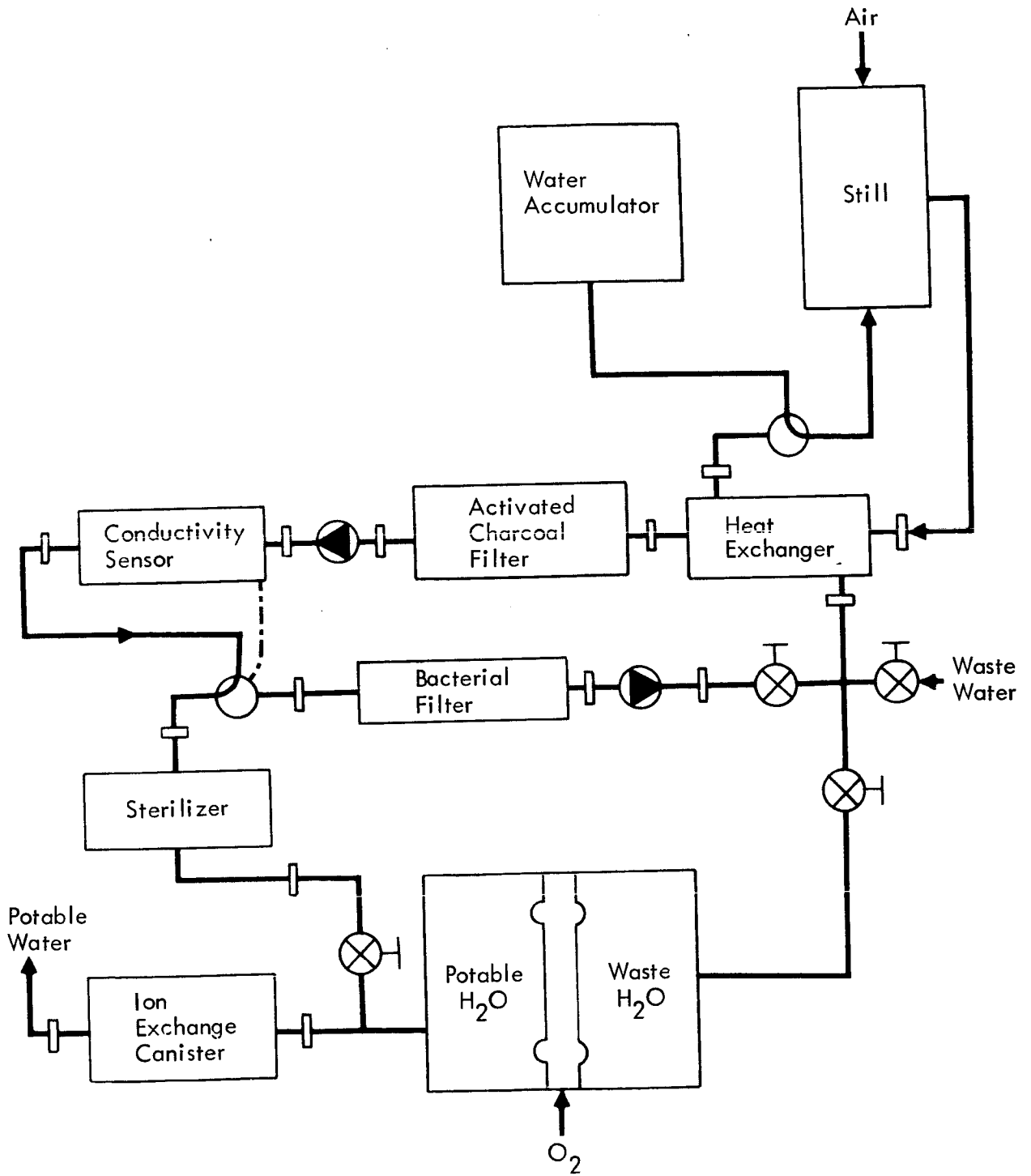

Figure D-3: VACUUM COMPRESSION DISTILLATION SYSTEM SCHEMATIC

Table D-10: VACUUM COMPRESSION DISTILLATION PARTS LIST

<u>Component</u>	<u>Weight (pounds)</u>	<u>Power (watts)</u>
Check Valve (2)	0.30	
Two-Way Hand Valve (4)	1.2	
Water Tank	18.8	
Activated Charcoal Filter (ACF)	2.5	
Bacterial Filter (BF)	2.6	
Sterilizer - AgCl	2.3	
Conductivity Sensor (CM)	1.9	2.3
Three-Way Solenoid Valve (2)	1.38	2.5
Three-Way Hand Valve	0.42	
Vacuum Compression Still	40.0	36.3
Heat Exchanger (HX)	0.55	
Air Heater	0.15	(18.0)
Blower	0.38	6.0
Vent	2.50	2.5
Accumulator-boiler	1.58	
Quick Disconnects (14)	4.2	
Ion Exchange Canister (D-50)	4.70	
Still Motor	2.00	6.0
Controls	<u>1.00</u>	<u>1.0</u>
	88.46 lbs	56.6 W _e 54.1 W _e (maximum continuous) (18.0 W _t)

D-5.3.2 VACUUM COMPRESSION DISTILLATION EXPENDABLES

Expendables for the urine water reclamation as estimated by Marquardt, Reference 17, for a six-man crew are:

$$\frac{155 \text{ pounds expendable/year}}{(\text{six men})(3.45 \text{ lb urine/man day}) 365 \text{ days/year}} = 0.0205 \text{ lb/lb urine}$$

$$\text{Volume} = 0.0205 (1728/30 \text{ pounds filter/foot}^3) = 0.118 \text{ in}^3/\text{lb urine}$$

The recovery efficiency is estimated at 98.6% of the available water.

$$\text{Water makeup} = 0.014 \text{ lb/lb urine.}$$

Table D-11 summarizes expendable and water makeup for the vacuum compression distillation concept:

Table D-11: MAXIMUM VACUUM COMPRESSION MAKEUP AND EXPENDABLES RATES

	Condensate (lb/lb Cond)	Wash (lb/lb Wash)	Urine (lb/lb Urine)
Expendables			
As calculated in Reference 17	0.0004*	0.0019*	0.0205
Total expendables rate: As shown			
Efficiency	98.6	98.6	98.6
Makeup Water (to balance 1.0 pound in/1.0 pound out)	0.0140	0.0140	0.0140
Total rate (lb/lb of waste water)	0.0144	0.0159	0.0345
*Assumed by comparison with other concepts.			

D-5.3.3 DEVELOPMENT

A vacuum compression distillation system fabricated for Langley Research Center under Contract NAS1-1225 has been built by General American Transport Corporation and tested at Langley. The four-man unit weighs 60 pounds and is about 2 feet high. It processes 2.3 lb/hr, requires 38 watt hr/lb of water recovered; expendable weight is 0.63 lb/lb urine and the efficiency is 97%.

A vacuum compression distillation system (48 pounds urine/day) has been manufactured by Marquardt for NASA-MSD under Contract NAS9-1680. In addition, Marquardt is currently under contract to build a three-man integrated urine loop and fecal loop under Contract NAS9-5119. This system consists of two vacuum distillation units, one for urine and one for fecal water reclamation. It is financed by NASA-MSD, and is being recommended for use in 1969 to 1975 spacecraft studies for NASA.

Development of the vapor compression concept from inception of the prototype phase through delivery of the first flight unit and ground support equipment is approximately 29 months.

D-5.4 REVERSE OSMOSIS

Reverse osmosis is the process whereby a contaminated waste product is placed next to a membrane, and subjected to a hydrostatic pressure that exceeds the osmotic pressure of the solution. Waste water subjected to these high-pressure conditions will result in water passing out of the solution, depending on the selective properties of the membrane.

A schematic from Reference 17 of a reverse osmosis process for recovering wash water is shown in Figure D-4. Wash water is collected from the hygienic facilities. The collection equipment includes a gas-liquid separator, a blower and air filter, a water booster pump, and valves. Particulate filters are used to remove the relatively large particles that might plug the membranes. A pH meter is used to check the water for alkalinity, since an alkaline waste will tend to shorten the membrane life.

Wash water is withdrawn from the used water storage tank and processed by a reverse osmosis unit. This unit contains a pressurizing pump, a pressure regulator, a membrane cell and a brine bypass pressure regulator. The cell contains a series of membrane pairs sealed to a porous support substrate. The membranes reject most of the dissolved solids and pass fresh water into the porous substrate, from which it is manifolded for delivery to the tanks at low pressure. Feed water is directed along a tortuous path by spiral baffles communicating with the face of the membrane. The feed water flows past several membrane pairs, becoming more concentrated as freshened water is removed. The resulting brine, approximately 5%, passes through a regulator to the urine or fecal water processing loop for further processing. Makeup water is returned to complete the wash water loop. A pressure regulator opens at relatively low pressure to allow brine to bypass back to the used wash water tanks if the fecal or urine waste tanks are hydrostatically filled with wastes. Without recovery of the brine water, the efficiency is about 95%; with recovery, it is approximately 99.5%.

The fresh wash water is monitored by conductivity meter, which operates a solenoid valve to bypass unacceptable water. An activated charcoal filter removes trace contaminants that may cause odor or taste. The water is sterilized by flow through a silver chloride column and returned to the fresh water storage tanks. It is withdrawn on demand at the hygienic facilities.

D-5.4.1 WEIGHT AND POWER

Table D-12 gives a listing of the weight and power for the major components. The unit is sized for 32.7 pounds water/day. The weight, power, and expendables are summarized below for the six-man wash water system.

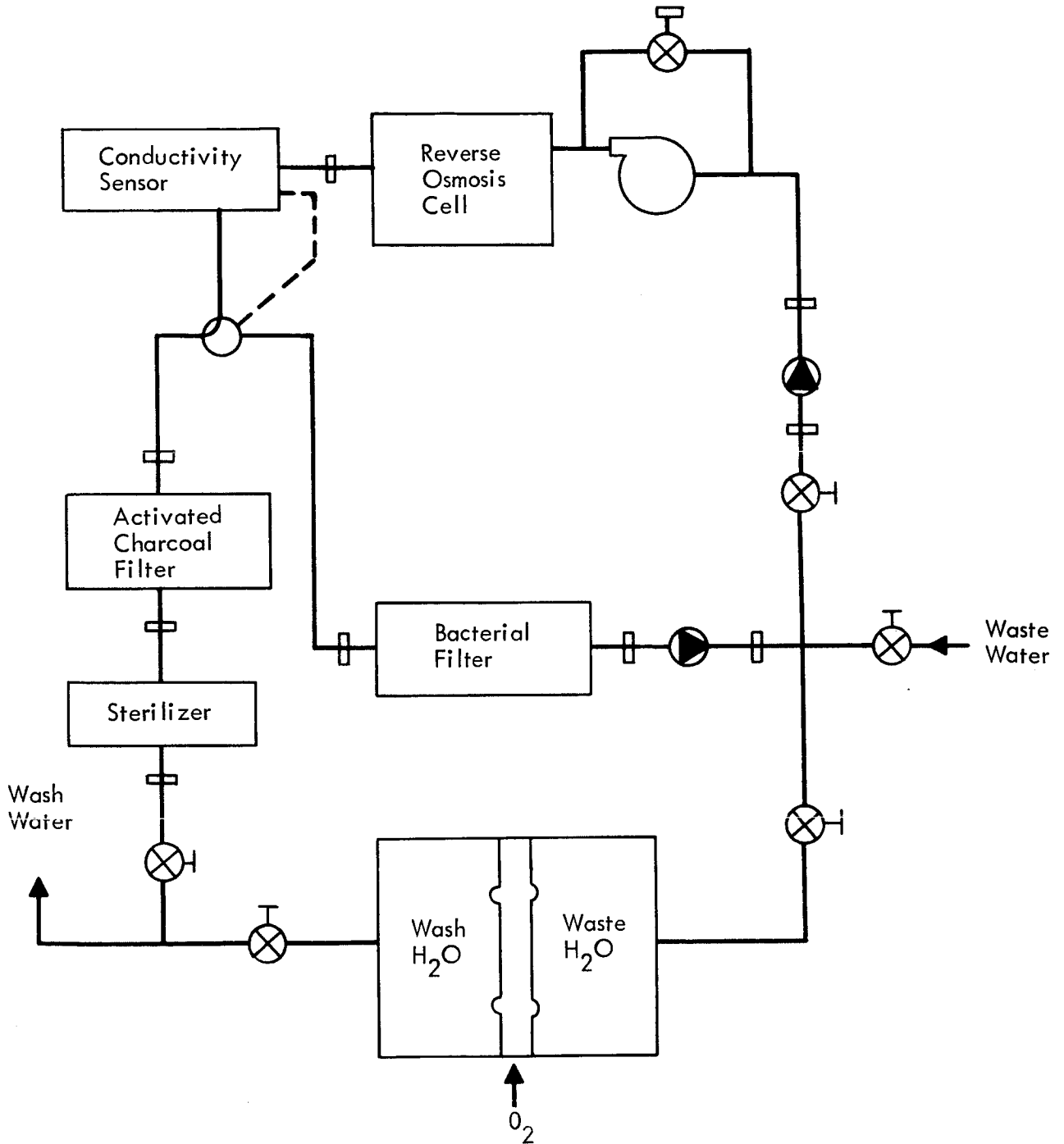

Figure D-4: REVERSE OSMOSIS SYSTEM SCHEMATIC

Table D-12: REVERSE OSMOSIS PARTS LIST

<u>Component</u>	<u>Weight (pounds)</u>	<u>Power (watts)</u>
Three-way Solenoid Valve	0.68	2.5
Check Valve	0.45	
Two-way Hand Valve	1.2	
Pump and Motor	11.80	35.0
Reverse Osmosis Cell	28.6	
Pressure Regulator	6.0	
Storage Tank	18.8	
Activated Charcoal Filter (ACF)	4.3	
Bacterial Filter	2.6	
Sterilizer-AgCl	2.3	
Conductivity Sensor	1.9	2.3
Controls	1.0	3.0
Quick Disconnects	3.6	
Plumbing and Electrical	<u>3.0</u>	
	86.23	42.8 W _e
		40.3 W _e
		(maximum continuous)

D-5.4.2 REVERSE OSMOSIS EXPENDABLES

Expendables for wash water as reported in Reference 17 are 125 pounds/year for six men at 26.4 pounds water/man.

$$\frac{125 \text{ pounds/year}}{(158.4 \text{ pounds H}_2\text{O/day})(365 \text{ days/year})} = 0.00216 \text{ lb/lb H}_2\text{O}$$

$$\text{Volume} = (0.00216)(1728)/30 \text{ pounds filter/foot}^3 = 0.125 \text{ in}^3/\text{lb H}_2\text{O}$$

The efficiency is approximately 95% with no brine water recovery and up to 99.5% if the brine water is recovered by a vacuum compression distillation technique.

$$\text{Makeup water} = 0.05 \text{ lb/lb waste water}$$

Makeup water and expendable rates are provided in Table D-13:

Table D-13: REVERSE OSMOSIS MAKE-UP AND EXPENDABLES RATES

	Condensate (lb/lb Cond)	Wash (lb/lb Wash)	Urine (lb/lb Urine)
<u>Expendables</u>			
As calculated from Reference 17	0.0004*	0.00216	---
Total expendable rates: as shown			
<u>Efficiency</u>			
With brine recovery	99.5	99.5	---
Without brine recovery	95.0	95.0	---
<u>Makeup Water</u> (to balance 1.0 pounds in/1.0 pounds out)			
With brine recovery	0.0050	0.0050	---
Without brine recovery	0.0500	0.0500	---
<u>Total rate</u> (lb/lb of waste water)			
With brine recovery	0.0054	0.00716	---
Without brine recovery	0.0504	0.05216	---
*Assumed by comparison with other concepts.			

D-5.4.3 DEVELOPMENT

Although the reverse osmosis process is well understood, there has been very little development of this concept for space application beyond the laboratory test setups. Some bench scale testing has been done by Radiation Applications, Inc.

Marquardt at this date reports that they have conducted some reverse osmosis work for recovery of wash water. Marquardt has proposed use of the reverse osmosis concept for wash water along with vapor compression for urine and fecal water recovery in their integrated water management subsystem.

Development time for reverse osmosis water reclamation is estimated to be approximately 24 months.

D-5.5 ELECTRODIALYSIS

Electrodialysis is a process which uses an electric field to separate ionic constituents from a waste stream. It does not separate nonionic constituents such as urea; therefore, this technique is dependent upon a pretreatment that completely removes the nonionic constituents. Reference 14 states that with the advent of electrical pretreatment, electrodialysis becomes very competitive. Unlike other techniques, the energy requirements for electrodialysis are primarily dependent upon the quality of solutes removed and not so much on the quantity of water processed.

In the electrodialysis process, ionized molecules or atoms are transferred through highly selective ion-transfer membranes under the influence of a direct current. If a solution containing positively and negatively charged ions is circulated through an electrodialysis cell, Figure D-5, the positively-charged ions (cations) will be attracted to the negatively-charged cathode and the negatively-charged ions (anions) will be attracted to the positively-charged anode. The nature of the ion-transfer membrane between the solution and the electrode (anode or cathode) determines whether or not an ion can migrate through it or be retained in the solution. Anion-transfer membranes will allow anions to pass through them but will block cations, while cation-transfer membranes will allow passage of cations but not anions. By proper arrangement of the different ion-transfer membranes, the electrolyte stream can be separated into a pure water stream and a concentrated brine. Approximately 5% of the total liquid feed will pass through the membranes as endosmotic water. Approximately 36% of the brine can be recovered by the membrane permeation technique. This results in an overall water recovery efficiency of approximately 96.8%. The residue from the permeable membrane is a thick homogeneous liquid collected in plastic containers and stored as waste, or subjected to further reclamation by vacuum compression, if such is available.

Figure D-6 shows a flow schematic of an electrodialysis water recovery system as developed by Ionics, Inc., Reference 26. Urine after collection is transferred to Reservoir 1, to which a complexing agent is added. The complexing agent reacts with the urea to form a flocculent precipitate. When Reservoir 1 is filled to a specified quantity as sensed by a quantity indicator, the transfer of urine to the reservoir is stopped and the reclamation process is activated. The waste water containing the urea precipitate is pumped through a series of charcoal filters to the circulation reservoir. The charcoal filter pretreatment removes the precipitate and all residual organic constituents from the waste liquid by absorption. A bacterial filter located upstream of the reservoir prevents transfer of bacteria. When the circulation reservoir is filled, a circulation pump is started to pass the organic free waste

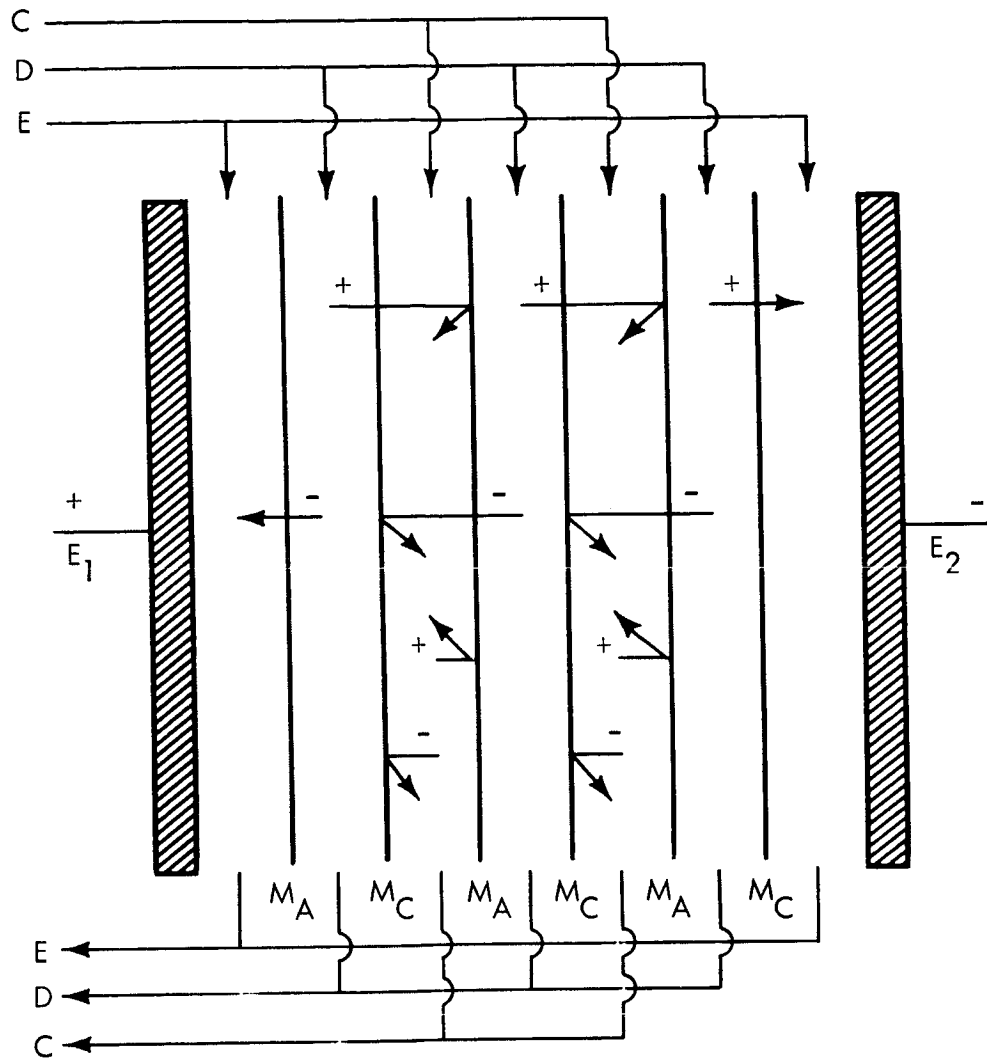

C = Concentrate Stream
 D = Diluting Stream
 E = Electrolyte Stream
 M_C = Cation Membrane
 M_A = Anion Membrane

Figure D-5: TYPICAL ELECTRODIALYSIS UNIT

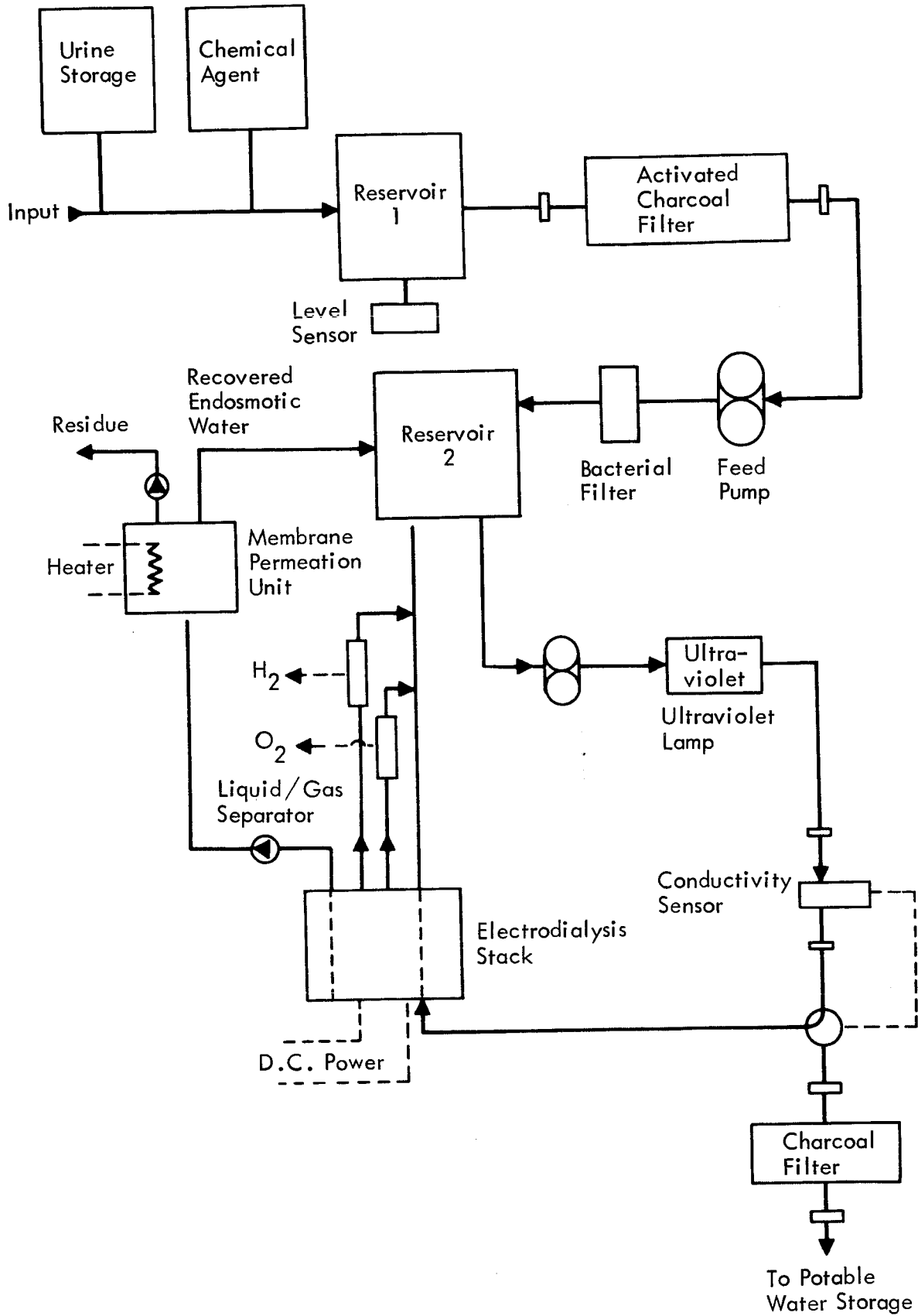

Figure D-6: SCHEMATIC OF ELECTRODIALYSIS WATER RECOVERY SYSTEM

water through the electrodialysis cells. The liquid is continuously recirculated through the electrodialysis cells or stack until the desired purity of the liquid stream is obtained as indicated by the conductivity controller. The controller then actuates a three-way valve to transfer the purified water through charcoal filters to the potable water storage tanks.

The charcoal filters remove any odors remaining in the processed water. Sterilization of the water is obtained by use of an ultraviolet lamp located in the circulation loop.

Gas-liquid separators are required to purge small quantities of hydrogen and oxygen generated at the cathode and anode of the electrolysis cells. The oxygen is vented to the cabin and the hydrogen is routed to a trace contaminant oxidizer.

The concentrate stream from the stack is fed directly to a selective membrane filter still for processing the endosmotic water in the concentrated stream. Of the 5% endosmotic water, approximately 36% can be recovered. The effluent leaving the membrane filter contains all the inorganic salts originally present and 3.2% of the total water processed. This gives an overall efficiency of 96.8% for the electrodialysis unit.

D-5.5.1 WEIGHT AND POWER

The weight and power for an electrodialysis water reclamation system are shown in Table D-14.

Table D-14: ELECTRODIALYSIS WATER RECLAMATION PARTS LIST

	<u>Weight (pounds)</u>	<u>Power (watts)</u>
Electrodialysis stack	3.5	15.3
Membrane permeation unit	0.6	4.0
Gas/liquid separators (2)	0.7	
Check valves (2)	0.30	
Three-way solenoid valve	0.5	10.0
Ultraviolet lamp	0.1	3.0
Pumps (2)	3.0	4.0
Conductivity probe and cell	1.9	1.0
Supports and Enclosure	6.0	
Reservoirs (2)	2.0	
Instruments and controls	1.0	3.0
Chemical dispenser	0.8	
Charcoal filter canister	1.0	
Supports and plumbing	5.0	
Quick disconnects (8)	<u>2.4</u>	
Total	28.8	30.3 W _e (Maximum continuous)

D-5.5.2 EXPENDABLES

The expendables for an electro dialysis water reclamation, Reference 27, using chemical additives and charcoal filter pretreatment, are shown in Table D-15:

Table D-15: ELECTRODIALYSIS MAKEUP AND EXPENDABLES RATES

	Condensate (lb/lb Cond)	Wash (lb/lb Wash)	Urine (lb/lb Urine)
<u>Expendables</u>			
Urea complexing agent	----	----	0.0049
Charcoal	0.0022*	0.0025*	0.0738
Water trapped in charcoal	<u>0.0002</u>	<u>0.0003</u>	<u>0.0074</u>
Total expendable rate	0.0024	0.0028	0.0861
<u>Efficiency (%)</u>			
With brine recovery	99.94	99.94	96.8
Without brine recovery	----	98.64	95.0
<u>Makeup Water (to balance 1.0 lb in/1.0 lb out)</u>			
With brine recovery	0.0006	0.0006	0.0320
Without brine recovery	----	0.0138	0.0500
<u>Total Rate (lb/lb of waste water)</u>			
With brine recovery	0.0030	0.0034	0.1181
Without brine recovery	----	0.0164	0.1361
*Assumed by comparison with other concepts.			

D-5.5.3 DEVELOPMENT

Large nonflight-weight commercial electro dialysis units performing similar water reclamation functions but with lower water recovery have been built and operated in considerable numbers for many years. A small unit has been built by Ionics, References 27 and 28, and operated in the laboratory. Ionics has also supplied the Air Force with an electro-dialysis system under Contract AF33(615)-429.

For the electro dialysis water reclamation concept to become competitive, the pretreatment penalty must be reduced. One method, as reported in Reference 14, is the use of electrolysis to decompose urea.

NASA Langley Research Center is promoting research in the area of urine pretreatment under Contract NAS1-4373. The pretreatment consists of an electrolysis technique to decompose urea into carbon dioxide, nitrogen, hydrogen and water. The decomposition takes place by way of the following series of reactions:

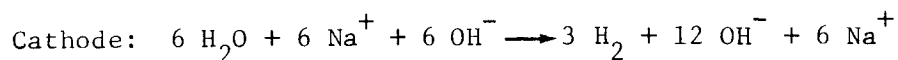
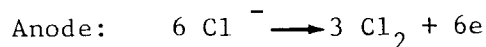

The chlorine produced at the anode reacts with the sodium hydroxide formed at the cathode to give hypochlorite ion

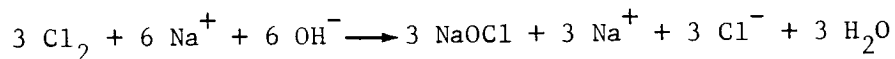

The hypochlorite ion oxidizes the urea via the known reaction

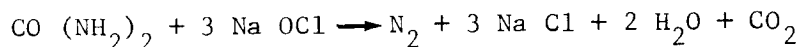

The sum of these equations is

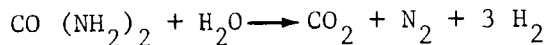

The hypochlorite formed in the reaction is a powerful oxidizer and disinfectant. It decomposes other organic compounds and sterilizes the water.

Elimination of the urea results in decreased weight penalties for the membrane processes, which generally require large amounts of pretreatment expandables.

Radiation Application, Inc., Long Island City, New York, between September, 1964, and October, 1965 conducted research, design, and development of an improved water reclamation system for manned space vehicles. This work is apparently for urine electrolysis or the pretreatment to decompose urea. Data on this process have not been obtained to date.

It is estimated that the development time for the electro dialysis techniques is approximately 24 months. Data on the electrolysis pretreatment is inadequate for estimating development time; however, based on fuel cell development and water electrolysis unit development, it should be between 24 and 36 months.

D-6.0 ESTIMATED COSTS

Development, unit, and spares costs were estimated according to the ground rules listed in Section D-6.1. Unit costs are for a single processing unit capable of recovering one of the waste waters. Table D-16 shows the estimated costs.

D-6.1 COSTING GROUND RULES AND ASSUMPTIONS

- Costs are based on weights as described in Section D-5.0 and estimated complexity factors were developed with data from Reference 17.
- Costs shown are for the uncommon equipment within a single loop and do not represent the total loop costs or total water management subsystem costs. Weight of uncommon equipment is approximately 60% of the total urine loop dry weight and 55% of the total wash water loop dry weight.
- Costs include prorata share of program management, subsystems integration and installation, and qualification testing.
- R&D costs include five test articles for systems tests, but do not include any systems test.
- Spares cost per pound was developed as follows:

$$\frac{\text{Total first unit cost}}{\text{Fixed weight (pounds)}} = \text{Spares dollars per pound.}$$

Table D-16: WATER MANAGEMENT SUBSYSTEM COSTS

<u>Water Reclamation System</u>	<u>Weight (pounds)</u>	<u>R&D Cost (thousands)</u>	<u>Unit #1 Cost (thousands)</u>	<u>Spares Cost (dollars/pound)</u>
Multifiltration (MF)	32.70	\$ 173.9	\$ 6.9	\$ 211
Air Evaporation (AE)	84.65	1,159.1	90.4	1,068
Vacuum Compression (VC)	88.46	1,660.9	133.0	1,504
Reverse Osmosis (RO)	86.23	1,696.5	129.5	1,502
Electrodialysis (ED)	26.23	1,359.8	44.9	1,712

PRECEDING PAGE BLANK NOT FILMED.

D2-113544-6

APPENDIX E

STUDY OF SPACEFLIGHT CONTROL SUBSYSTEMS

CONTENTS

	<u>Page</u>
E-1.0 SUBSYSTEM DEFINITION	253
E-1.1 Candidate Spaceflight Control Concepts	253
E-1.2 Subsystem Description	253
E-1.3 Subsystem Components Common to All Concepts Studied	253
E-2.0 GROUND RULES AND BASELINE ASSUMPTIONS	256
E-2.1 Mission Assumptions, Interplanetary Missions	256
E-2.2 Mission Assumptions, NSS Missions	258
E-3.0 SPACEFLIGHT CONTROL CONCEPTS INVESTIGATED	259
E-4.0 METHOD OF COMPARISON	260
E-5.0 DESCRIPTIONS OF CANDIDATE SPACEFLIGHT CONTROL CONCEPTS	262
E-5.1 Description of the CMG/RCJ Spaceflight Control Subsystem	262
E-5.1.1 Component Functions	262
E-5.1.2 Interplanetary CMG/RCJ Subsystem Description	262
E-5.1.3 Earth Orbital (NSS) CMG/RCJ Subsystems	266
E-5.2 Description of RCJ Spaceflight Control Subsystems	266
E-5.2.1 Interplanetary RCJ Subsystem	266
E-5.2.2 Earth Orbital (NSS) RCJ Spaceflight Control Subsystem	270
E-5.3 Subsystem Development Times	270
E-6.0 ESTIMATED COSTS	274

E-1.0 SUBSYSTEM DEFINITION

E-1.1 CANDIDATE SPACEFLIGHT CONTROL CONCEPTS

Two concepts are studied, which differ only in the method of providing spacecraft control torques. The first concept employs both control moment gyros (CMG) and reaction control jets (RCJ) as torquing sources. The second concept relies only on RCJ's to provide the necessary torques. The determination of the optimal method of providing torques is the end purpose of this appendix.

E-1.2 SUBSYSTEM DESCRIPTION

A general diagram of the spaceflight control subsystem is shown in Figure E-1. Torqueing will be provided by CMG's and RCJ's or by RCJ's alone. The balance of the equipment shown is common to both concepts investigated. The diagram is applicable for either of the candidate systems except for the presence of the CMG's. Information from the two-axis Sun sensor and the horizon scanner is supplemented by information from the rate gyros as integrated to provide position signals. The manual control signals are put into acceptable form in the manual control signal converter and can be used to supplement or override the sensor signals. The information is processed by the digital control logic to command the necessary control torques to achieve the desired spacecraft attitude. The control torques are provided by the CMG's or the RCJ's, or both, depending on the system selected. Display information is provided to the pilot, who can override the mode selector. The ground communications link is shown to indicate the capability of directly addressing the digital control logic and for purposes of telemetry of data in either direction (Earth-space station or space station-Earth). Three modes of operation are indicated: reference for automatic control, manual, and spin for artificial g operation.

E-1.3 SUBSYSTEM COMPONENTS COMMON TO ALL CONCEPTS STUDIED

Two-axis Sun sensor: provides two-axis error signals to the digital control logic. When the vehicle is in shadow, the threshold level signal automatically switches control to the reference set and the mode selector is reset by the digital control logic. The two-axis Sun sensor will be used in all four configurations of the interplanetary mission.

Horizon scanner: provides two-axis error signals to the digital control logic. The horizon scanner will be used in the Earth orbit and planetary orbit configurations.

Two-axis star tracker: provides two-axis error signals to the digital control logic. The star-tracker can be used as a reference for precision pointing. It will be employed during the outbound and return configurations.

Rate gyros: provide supplementary information to the digital control logic for use with information from the sensors. The rates can be integrated to get position information. The gyros are used for long-term attitude hold in all configurations.

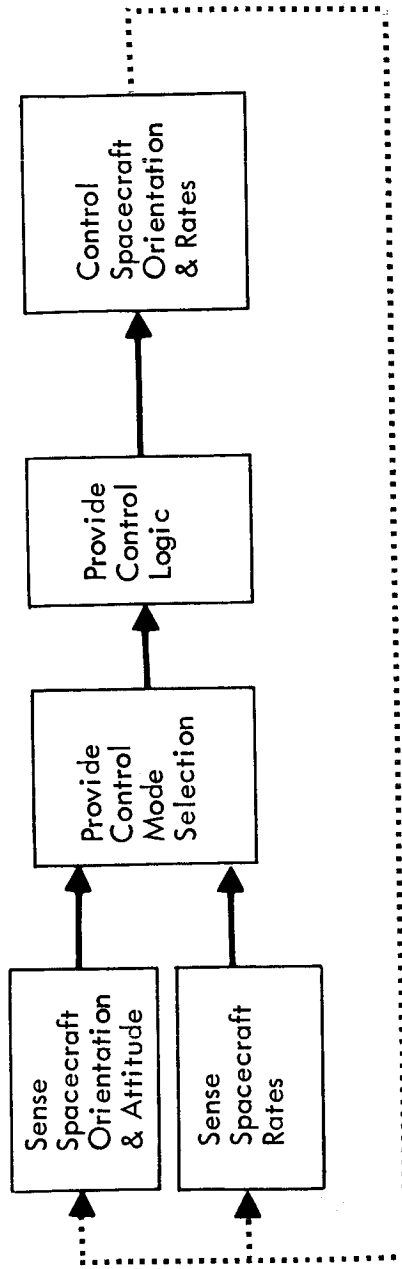

Figure E-1: SPACE FLIGHT CONTROL FUNCTIONS

Manual control: provides error signals to the digital control logic. The pilot's commands are processed in a manual signal converter to generate the error signals. Manual command resets the mode selector automatically. This is available in all configurations.

Mode selector: provides signals to the digital control logic to select the appropriate sensors. It can be reset by command from the digital logic, triggered by manual command or Sun-sensor threshold. The mode selector is used in all configurations.

Digital control logic: processes the error signals from the sensor and the reference signals from the position and rate gyros to determine the attitude. The control logic, or computer, commands the RCJ's or CMG's to torque the vehicle to the desired attitude. The logic also processes ground communication signals and manual signals as required. The digital control logic is used in all configurations.

E-2.0 GROUND RULES AND BASELINE ASSUMPTIONS

E-2.1 MISSION ASSUMPTIONS, INTERPLANETARY MISSIONS

Background:

Four vehicle configurations are major considerations in the mission:

- 1) Earth orbital (pre-injection),
- 2) outbound (post injection),
- 3) planetary orbital (post braking),
- 4) return.

In Earth orbit the vehicle will be oriented X axis to local vertical. One hour prior to injection, the vehicle will be maneuvered to the injection attitude a maximum of 180 degree pitch and yaw (X axis alignment). After injection the injection stage is dropped, yielding the second configuration. The vehicle will be oriented to the Sun during the outbound leg. Sometime prior to arrival at the target planet, the vehicle will be maneuvered for braking, a maximum of 180 degrees. After the target planet capture the braking stage will be dropped, yielding the third configuration. During orbit of the target planet the vehicle will be oriented with the Z axis on the local vertical, such that only single gimbaling of solar arrays is required. Prior to departure from the planet, the vehicle will be oriented to the departure attitude in a manner similar to departure from Earth. After departure the third propulsion stage will be dropped, leaving the fourth configuration. On the return leg, it will be oriented so that the solar array gimbaling can Sun orient the array. Array drive rate will be 5 deg/min.

Specific requirements:

Number of maneuvers:	Approximately 22 (including attitude changes for midcourse corrections and major ΔV changes).
Amplitude of maneuvers:	Three of 180 degrees (in Configurations 1, 2, and 3); 19 of less than 45 degrees (2 in Configuration 1, 7 in 2, 5 in 3, and 6 in 4).
Maneuver rates:	0.1 deg/sec for the three 180-degree maneuvers. 0.05 deg/sec for all other maneuvers.
Orientations: Geo-center	X axis to local vertical for 30 days in Configuration 1. Z axis on local vertical for 30 days in Configuration 3.

Inertial X axis to Sun in transit: 180 days in Configuration 2; 240 days in Configuration 4.

Other As required for midcourse and major maneuvers.

Accuracy of orientation: See Table E-1.

Table E-1: ORIENTATION AND CONTROL ACCURACIES

Configuration	Orientation Accuracy				Times
	0.003 deg/sec		0.003 deg/sec		
	Accuracy	% of Time	Accuracy	% of Time	
1) Earth Orbit	$\pm 2^{\circ}$	90	$\pm .5^{\circ}$	10	30 days
2) Outbound	$\pm 2^{\circ}$	89	$\pm .1^{\circ}$	11	180 days
3) Mars Orbit	$\pm 2^{\circ}$	50	$\pm .5^{\circ}$	50	30 days
4) Return	$\pm 2^{\circ}$	89	$\pm .1^{\circ}$	11	240 days

0.1 deg/sec turn rate required for major maneuvers.
10 deg/hr (0.003 deg/sec) limit cycle rate.

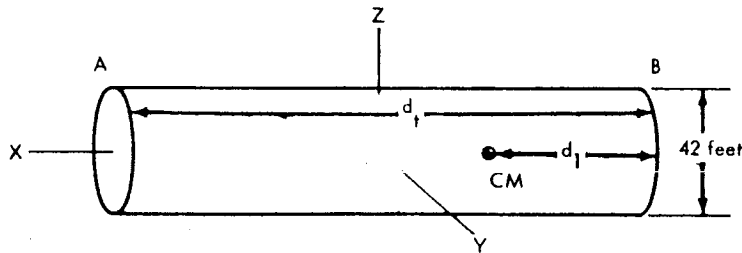

Approximate c.g.'s and inertias (not including solar arrays)
(NNN/1982 Opp/42-ft-diameter space vehicle)

Configuration	Weight (lb)	d_1 (ft)	d_t (ft)	$I_{z&y}$ (10^6 slug-feet ²)	I_x (10^6 slug-feet ²)
1) Earth Orbit	1,880,800	246	466	880	88
2) Outbound	937,100	138	261	162	16
3) Mars Orbit	453,100	104	180	14	1
4) Return	122,300	57	86	0.5	0.05

Figure E-2: INTERPLANETARY VEHICLE CHARACTERISTICS

Two solar arrays will be located one on either side of the vehicle with rotational axis parallel to the Y axis, Figure E-2. Each array will be square, 3200 square feet, and rotated about the center line of the array. The moment of inertia of each array, about the rotation axis, is $I = 11.5 \times 10^3$ slug-feet². The rotation axis of the arrays is 30 feet from end B of the configuration shown. The c.g. of each array is 50 feet from the X axis.

A single large parabolic antenna will be located on the Z axis in the same relative position as the solar arrays. The antenna will have two degrees of freedom. It is 315 square feet and has $I = 34.4$ slug-feet² about a single axis in the plane of the antenna through the antenna c.g.

The mission can be resupplied during Earth orbit up to injection time minus 1 day.

E-2.2 MISSION ASSUMPTIONS, NSS MISSIONS

The space station is an Earth orbiting vehicle that is assumed similar to the Douglas MORL. After deployment, the vehicle acquires the Sun and stabilizes the solar cell array to the Sun line-of-sight (LOS) with an accuracy of ± 15 degrees about the X and Y axes. The attitude control system (ACS) will control the orbit configuration to attitudes or angular rates that minimize the effects of gravity gradient torques. During ferry and resupply docking periods, the ACS will inertially stabilize the docking receptacle. The ACS will also be required to establish and maintain the necessary spin rates to provide artificial g up to 1 g with an accuracy of 10%.

$$\begin{aligned} \text{Inertias:} \quad I_x &= 135,600 \text{ slug feet}^2 \\ I_y &= 1,626,000 \text{ slug feet}^2 \\ I_z &= 1,698,000 \text{ slug feet}^2 \end{aligned}$$

Moment arms for rocket engines and crew deck:

$$\begin{aligned} X &\text{ --- } 5.3 \text{ feet} \\ Y &\text{ --- } 43 \text{ feet} \\ Z &\text{ --- } 43 \text{ feet} \\ \text{c.g. to floor} &\text{ --- } 29.7 \text{ feet} \end{aligned}$$

E-3.0 SPACEFLIGHT CONTROL CONCEPTS INVESTIGATED

Only two concepts were investigated. As stated previously, these concepts are control by RCJ's, and control by CMG's assisted by RCJ's. RCJ's are used with the CMG's to desaturate the gyros when required and to swing the vehicle in preparation for major propulsion maneuvers.

E-4.0 METHOD OF COMPARISON

The space flight control concepts described in this appendix are to be compared so that the most desirable concept can be selected. To make a determination of cost effectiveness possible, the concepts are specified for a point of equivalent performance. The concepts as described will meet or exceed the assumed requirements and are augmented with optimally selected spares so that they have equal reliability.

The cost effectiveness determination was made according to the following equations which translate major subsystem parameters into costs:

$$C_T = C_{nr} + C_{rec} + C_{acc} + C_{spr}$$

where

- C_T = total cost
- C_{nr} = nonrecurring cost
- C_{rec} = recurring cost
- C_{acc} = acceleration cost
- D_{spr} = cost of spares

$$C_{nr} = C_{te} + C_d$$

where

- C_{te} = technology development cost
- C_d = R&D cost

$$C_{rec} = C_r \times (M_1 + M_2) + C_p \times (M_1 \times P_e + M_2 \times P_m)$$

where

- C_r = unit cost of flight hardware
- M_1 = number of orbital flights
- M_2 = number of interplanetary flights
- C_p = cost of electrical power (dollars/watt)
- P_e = electrical power required for Earth orbital missions
- P_m = electrical power required for interplanetary missions

$$C_{acc} = M_2 \times [C_4 \times (W_r \times T_{13} + P_m \times P_p \times W_{f4} + W_{s1}) + C_3 \times (W_r \times T_{12} + W_{f3}) \\ + C_2 \times (W_r \times T_{11} + W_{f2}) + C_1 \times W_{f1}] + C_1 \times [M_1 \times (W_f + P_e \times P_p) \\ + W_{s2} + W_{s3} + W_{s4} + W_r \times T_{m1}]$$

where

- C_4 = interplanetary round-trip acceleration cost in \$/lb
 C_3 = acceleration cost to a planetary orbit in \$/lb
 C_2 = acceleration cost to the initial interplanetary trajectory, \$/lb
 C_1 = acceleration cost to Earth orbit, \$/lb
 W_r = weight rate of expendables in pounds/day
 T_{13} = return leg time in days
 T_{12} = planetary orbit time in days
 T_{11} = outbound leg time in days
 P_p = power penalty in pounds/watt
 W_{f4} = subsystem weight which makes the complete trip
 W_{f3} = subsystem weight which goes to planetary orbit only
 W_{f2} = subsystem weight which goes to the first leg only
 W_{f1} = subsystem weight which goes to Earth orbit only
 W_{s1} = weight of spares for interplanetary missions
 W_{s2} = weight of spares for the 2-year NSS mission
 W_{s3} = weight of spares for the 3-year NSS mission
 W_{s4} = weight of spares for both the 5-year NSS missions
 T_{m1} = total length of Earth orbital missions in days.

$$C_{spr} = C_{sw} \times (M_2 \times W_{s1} + W_{s2} + W_{s3} + W_{s4})$$

where C_{sw} = cost of spares weight in \$/lb.

E-5.0 DESCRIPTIONS OF CANDIDATE SPACEFLIGHT CONTROL CONCEPTS

The following paragraphs describe the two candidate spaceflight control concepts. Description of the concepts is encumbered by the fact that one subsystem is not practical for use in both the Earth orbital missions and the interplanetary missions. For this reason, subsystems for both classes of missions are described. There are a number of items common to all subsystem concepts; these are listed in Table E-2.

E-5.1 DESCRIPTION OF THE CMG/RCJ SPACEFLIGHT CONTROL SUBSYSTEM

In this general paragraph two subsystems will be described: the Earth orbital subsystem and the interplanetary subsystem. The primary differences between these subsystems are the size (weight) of the CMG's required and the amount of propellant necessary.

E-5.1.1 COMPONENT FUNCTIONS

The components common to all concepts are described in Section E-1.0. Note that the star tracker is required for interplanetary missions only. In addition to the common items the CMG/RCJ subsystems will require the following components.

- Control moment gyros provide attitude hold when disturbances are small; counteract oscillatory components of long-term, low-torque disturbances; provide low-rate attitude maneuvering; and counteract short-period, high-torque internal disturbances. The CMG's are momentum storage devices that permit the conservation of propellant otherwise expended by the reaction control jets. As a gyro reaches saturation, the reaction control jets are activated to desaturate it. The CMG's will be employed in all configurations as a coning suspension with 2000 ft/lb/sec rotors.
- Reaction control jets provide control torques by mass expulsion. The RCJ's will be used to damp out large disturbances, provide maneuver rates, and desaturate the control moment gyros.

Figure E-3 shows the relationship of major components for both the NSS and interplanetary missions.

E-5.1.2 INTERPLANETARY CMG/RCJ SUBSYSTEM DESCRIPTION

Control moment gyros are used in this concept to maintain the space vehicle attitude as required during the various phases of the mission. Reaction control jets are required to desaturate the CMG's (once a day in Earth and planetary orbit) and to maneuver the vehicle when large angles must be swung in relatively short periods of time. Expenditure of RCJ propellant is shown in Table E-3. It is important to note that the control moment gyros can hold the vehicle attitude to a much closer tolerance than is specified in Table E-1. This is a significant advantage to the experiment subsystem when high experiment pointing accuracies are required. The assumed tolerances were based on the IMISCD experiment subsystem, which includes stabilization platforms for the experiments when high pointing accuracy is required.

Table E-2: COMMON SPACEFLIGHT CONTROL ITEMS

Identification/ Nomenclature	Weight (lb)	Power (kw)	Area/* Volume	Lead Time		Cost (in millions)		Remarks
				Technology	R&D	R&D**	First Article	
Two-Axis Sun Sensor	0.3	0.005						
Horizon Scanner	0.3	0.005						
Rate Gyro(s)	1.0	0.010						
Displays	24.0	0.075						
Manual Controls	1.0							
Manual Signal Converter	10.0	0.020						
Mode Selector	1.0							
Digital Control Logic	40.0	0.150						
RCJ Driver Assembly	18.6							
	96.2	0.265			0	38.0	1.9	

*enter area or volume if pertinent **including flight test

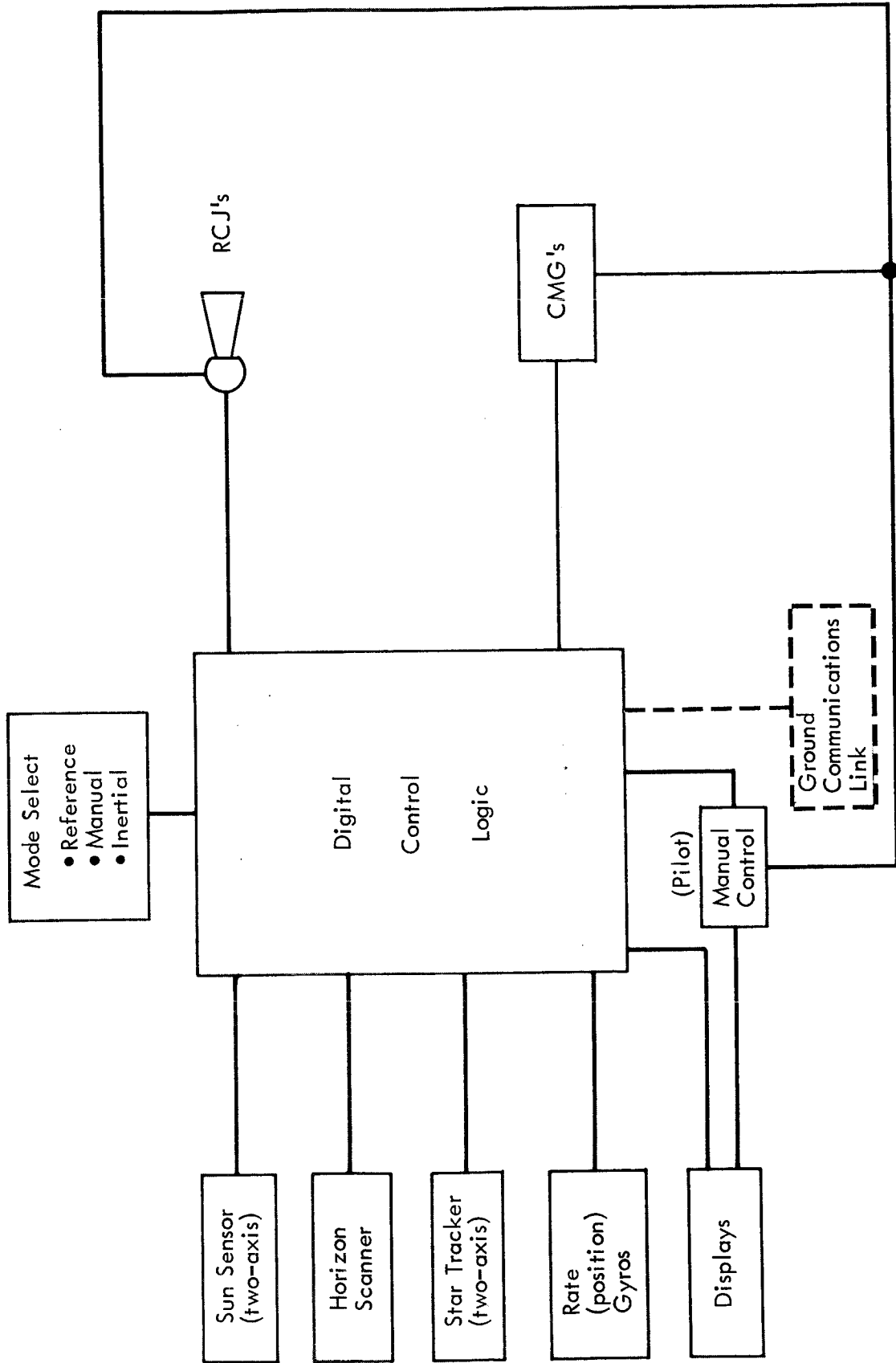

Figure E-3: SPACE FLIGHT CONTROL SUBSYSTEM DIAGRAM

Table E-3: PROPELLANT REQUIRED (RCJ + CMG)

One (1) 180 Degree Maneuver (P&Y axis)	
	Pounds
Earth orbit	172.0
Outbound	28.4
Mars orbit	3.6
Maneuvers of Less than 45 Degrees	
Earth orbit (2)	172.0
Outbound (7)	100.0
Mars orbit (5)	9.0
Return (6)	1.0
Damp Out Worst Case 3 Deg/Sec	1230.0
Rate in Earth orbit	
Including c.g. offset	
Periodic Desaturation of CMG's	
Assume desaturate once every day	
Earth orbit (30 times)	11.4
Outbound (180 times)	76.6
Mars orbit (30 times)	14.8
Return (240 times)	186.4
	<hr/>
Total	2005.2 pounds

The weight and power for the interplanetary subsystem is summarized in Table E-4. In order to properly allocate acceleration cost, the weight summary must be broken down into stage weights for each phase of the interplanetary mission. This is shown in Table E-5. The weight of engines, tankage, and distribution is affected by mission phase, because it is assumed that some tanks and engines will remain with the spent propulsion stages.

E-5.1.3 EARTH ORBITAL (NSS) CMG/RCJ SUBSYSTEMS

The function of the Earth orbital CMG/RCJ subsystem is similar to that for the interplanetary subsystem. In orbit, however, the space station could be geocenter oriented, solar oriented, or oriented to some other celestial body of interest. The subsystem specified assumes sun orientation. If orientation is to another star, a star tracker must be added to the subsystem. The remaining hardware difference is the CMG's, which are much smaller than for the interplanetary mission because of the much lower space station inertia. A summary of subsystem weights is provided as Table E-6.

E-5.2 DESCRIPTION OF RCJ SPACEFLIGHT CONTROL SUBSYSTEMS

The RCJ space flight control subsystems use mass expulsion to provide spacecraft attitude control and stabilization. The accuracy specified in the assumed requirements, Section E-2, Table E-1, represents approximately the limit for mass expulsion concepts using bipropellants. Fine control might be achieved by the use of cold gas jets; however, this additional equipment was not considered because the specified subsystem meets the mission requirements.

E-5.2.1 INTERPLANETARY RCJ SUBSYSTEM

Propellant expenditure for the RCJ interplanetary subsystem is shown in Table E-7. It may be seen that propellant requirements are in most cases identical to the propellant requirements for the CMG/RCJ subsystem (Table E-3). This is not unexpected because major maneuvering is performed by RCJ's in the CMG/RCJ subsystem. The point of difference is in the propellant allocated to damping out accumulated disturbances. The amount of propellant allocated for this purpose is dependent on the rate of limit cycling assumed for the vehicle. Ten degree/hour was assumed (0.003 deg/sec) in this study as a reasonable rate.

If the limit cycle rate should be increased significantly, this could have a significant effect upon the trade between the CMG/RCJ subsystem and the RCJ subsystem, making the CMG subsystem appear more desirable. Weights for the RCJ interplanetary subsystem are summarized in Table E-8. Stage weights are shown in Table E-9 and can be compared to the CMG/RCJ stage weights in Table E-5.

Table E-4: TOTAL WEIGHT AND POWER: INTERPLANETARY CMG/RCJ SUBSYSTEM

Identification/ Nomenclature	Weight (lb)	Power (kw)	Area/ Volume	Lead Time		Cost (in millions)		Remarks
				Technology	R&D	R&D**	First Article	
Common Items	96.2	0.265				38.0	1.9	
Star Tracker	7.0	0.005				2.0	0.1	
CMG's	960.0	0.274†		2	4	94.0	9.2	
	1063.2	0.544						
Propellant	2055.2							
Engines, Dist., and Tankage	400.0					60.0	1.1	
	3468.4	0.544				194.0	12.3	
Spares	235.0						0.124/lb	For 500 days

*enter area or volume if pertinent **including flight test †assuming 1980 technology

Table E-5: TOTAL WEIGHT AND POWER, BY STAGE (CMG/RCJ)

In all configurations, the weight of all items except the reaction control propellant and the associated tankage, engine, and structure will be the same.

Fixed Weight for all Configurations		1063.2 pounds
Earth Orbit:	(Includes Weight for Additional Configurations)	
	Fixed weight	1063.2 pounds
	RCJ propellant	2005.2
	RCJ engines, distribution, tankage	400.0
	Total	<u>3468.4</u>
Outbound:		
	Fixed weight	1063.2
	RCJ propellant	649.8 (a)
	RCJ engines, distribution, tankage	400.0
	Total	<u>2113.0</u>
Planet Orbit:		
	Fixed weight	1063.2
	RCJ propellant	244.8 (b)
	RCJ engines, distribution, tankage	130.0
	Total	<u>1438.0</u>
Return:		
	Fixed weight	1063.2
	RCJ propellant	192.4 (c)
	RCJ engines distribution, tankage	49.0
	Total	<u>1304.6</u>

- (a) Includes 230 pounds of propellant to damp out worst case.
3 deg/sec rate.
- (b) Includes 30 pounds of propellant to damp out worst case.
3 deg/sec rate.
- (c) Includes 5 pounds of propellant to damp out worst case.
3 deg/sec rate.

Table E-6: WEIGHT AND POWER SUMMARY: NSS CMG/RCJ SPACEFLIGHT CONTROL SUBSYSTEM

Identification/ Nomenclature	Weight (lb)	Power (kw)	Area/ Volume	Lead Time		Cost (in millions)		Remarks
				Tech	R&D	R&D**	First Article	
Common Items	96.2	0.265				38.0	1.9	
CMG's	169.0	0.315				16.5	2.9	Includes electronics
RCJ Engines, Dist. & Tankage	170.0					36.0	0.6	
	435.2	0.580				90.5	5.4	
Spares	270.0							For 2 years
	313.0							For 3 years
	374.0							For 5 years
Propellant	850/ year							

*enter area or volume if pertinent **including flight test

Table E-7: PROPELLANT REQUIRED (RCJ ONLY)

	<u>(pounds)</u>
180 Degree Maneuver (P&Y axis)	
Earth orbit	172.0
Outbound	28.4
Mars orbit	3.6
Maneuvers of Less Than 45 Degrees	
Earth orbit (2)	172.0
Outbound (7)	100.0
Mars orbit (5)	9.0
Return (6)	1.0
Damp Out Worst Case 3 Deg/Sec	1230.0
Damping Out Accumulated Disturbances	<u>660.0</u>
Total	2379.0

E-5.2.2 EARTH ORBITAL (NSS) RCJ SPACEFLIGHT CONTROL SUBSYSTEM

The NSS version of the RCJ spaceflight control subsystem will operate exactly like its interplanetary counterpart. The discussion of station attitude provided in Section E-5.1.3 applies to the RCJ subsystem as well. The amount of propellant will depend to some extent upon the required vehicle orientation, but this is not assumed to be a significant factor because of the small size of the vehicle compared to the interplanetary vehicles. Table E-10 summarizes the subsystem weights.

E-5.3 SUBSYSTEM DEVELOPMENT TIMES

The subsystem hardware specified for the NSS missions is readily available, in fact some of it is off-the-shelf hardware. The interplanetary missions, which occur in the 1980's, can take advantage of current technological improvements. This applies in particular to the larger CMG's required for the interplanetary vehicles. Attention should be given to developing methods of replacing or repairing CMG bearings, drive motors, and torquers. It is expected that all of the concepts described can be ready when required, therefore hardware availability should be no problem for the space flight control subsystem.

Table E-8: TOTAL WEIGHT AND POWER: INTERPLANETARY RCJ SUBSYSTEM

Identification/ Nomenclature	Weight (lb)	Power (kw)	Area/* Volume	Lead Time		Cost (in millions)		Remarks
				Technology	R&D	R&D**	First Article	
Common Items	96.2	0.265				38.0	1.9	
Star Tracker	7.0	0.005				2.0	0.1	
RCJ Engines, Dist. & Tankage	475.8				4+	65.0	1.2	
	579.0	0.270				105.0	3.2	
Spares	140.0							For 500 days

*enter area or volume if pertinent **including flight test †including qualification

Table E-9: TOTAL WEIGHT AND POWER, BY STAGE (RCJ ONLY)

In all configurations, the weight of all items numbered 1 through 10 will be included. Only the weights associated with the reaction control system will change.

Fixed Weight for all Configurations		103.2 pounds
Earth orbit:		
Common items	103.2	
RCJ propellant	2379.0	
RCJ engines, distribution, tankage	475.8	
Total	2958.0	
Outbound:		
Common items	103.2	
RCJ propellant	1005.9	(a)
RCJ engines, distribution, tankage	475.8	
Total	1584.9	
Mars orbit:		
Common items	103.2	
RCJ propellant	502.9	(b)
RCJ engines, distribution, tankage	201.2	
Total	807.3	
Return:		
Common items	103.2	
RCJ propellant	431.0	(c)
RCJ engines, distribution, tankage	100.6	
Total	634.8	

- (a) Includes 230 pounds of propellant to damp out worst case 3 deg/sec rate.
- (b) Includes 30 pounds of propellant to damp out worst case 3 deg/sec rate.
- (c) Includes 5 pounds of propellant to damp out worst case 3 deg/sec rate.

Table E-10: WEIGHT AND POWER SUMMARY: NSS RCJ SPACEFLIGHT CONTROL SUBSYSTEM

Identification/ Nomenclature	Weight (lb)	Power (kw)	Area/ Volume*	Lead Time		Cost (in millions)		Remarks
				Technology	R&D	R&D**	First Article	
Common Items	96.2	0.265				38.0	1.9	
RCJ Engines, Dist. & Tankage	390.0					58.0	1.0	
	486.2	0.265				96.0	2.9	
Spares	160.0						0.010/lb	For 2 years
	186.0						0.010/lb	For 3 years
	223.0						0.010/lb	For 5 years
Propellant	1950/ year							

*enter area or volume if pertinent **including flight test

E-6.0 ESTIMATED COSTS

Costs were estimated for the various space flight control subsystems according to the assumptions and ground rules below. Costs are shown on each of the weight statement data sheets in Section E-5 and in Table E-11.

- Costs were developed from parametric costing graphs and are based on subsystem weights.
- Spares costs can be developed as follows:

$$\frac{\text{Unit No. 1 Cost}}{\text{Weight}} = \text{Spares cost per pound}$$

- No learning considered in the development of unit cost.
- Costs shown are for complete attitude control subsystems and include subsystem integration and testing.
- In this study, the space flight control subsystem includes: guidance and navigation, stabilization and control, and reaction control.

Table E-11: SPACEFLIGHT CONTROL COSTS

	Weight (pounds)	R&D Costs (millions)	No. 1 Unit Cost (millions)
Interplanetary Mission			
RCJ/CMG			
Common items*	103.2	\$ 40.0	\$2.0
CMG assembly and electronics	960.0	33.0	2.6
RCJ engines, distribution and tanks	400.0	60.0	1.1
	<u>1,463.2</u>	<u>133.0</u>	<u>5.7</u>
RCJ/CMG--Total	<u>1,463.2</u>	<u>133.0</u>	<u>5.7</u>
RCJ Only			
Common items*	103.2	40.0	2.0
RCJ engines, distribution and tanks	475.8	65.0	1.2
	<u>579.0</u>	<u>105.0</u>	<u>3.2</u>
RCJ only--Total	<u>579.0</u>	<u>105.0</u>	<u>3.2</u>
National Space Station (NSS)			
RCJ/CMG			
Common items*	96.2	38.0	1.9
CMG assembly and electronics	169.0	17.5	1.0
RCJ engines, distribution and tanks	170.0	36.0	0.6
	<u>435.2</u>	<u>91.5</u>	<u>3.5</u>
RCJ/CMG--Total	<u>435.2</u>	<u>91.5</u>	<u>3.5</u>
RCJ Only			
Common items*	96.2	38.0	1.9
RCJ engines, distribution and tanks	390.0	58.0	1.0
	<u>486.2</u>	<u>96.0</u>	<u>2.9</u>
RCJ only--Total	<u>486.2</u>	<u>96.0</u>	<u>2.9</u>

*The only difference under "Common Items" is the deletion of a 7-pound star tracker--not required for the NSS.